



Digitized by the Internet Archive
in 2007 with funding from
Microsoft Corporation



Century; ...

SCRIBNER'S

MONTHLY,

An Illustrated Magazine

For the People.

Conducted by J. G. Holland.

Volume XIX.

(Nov., 1879, to April, 1880, inclusive.)

New-York:

Scribner & Co., No. 743 Broadway.

1880.

146981.
12/9/18.

CONTENTS VOL. XIX.

FRONTSPIECES TO VOLUME.	Portrait of Peter the Great. From the steel-engraving by J. Houbraken, after the painting by C. de Moor. Engraved by R. Müller.	
	Flag of Peter the Great, and Autograph of Thomas A. Edison.	
FRONTSPIECES TO NOVEMBER NUMBER.	Portrait of Bayard Taylor. From photograph by F. Gutekunst. Engraved by T. Cole.	
	The Cornell University Memorial of Bayard Taylor. From the bass-relief by W. R. O'Donovan. Engraved by F. Juengling.	
ACADIANS OF LOUISIANA, THE.		R. L. Daniels..... 383
Illus.	Acadian Girl. Illustrations by Allen C. Redwood.	
	A Young Matron..... 385	An Attakapas Herdsman..... 389
	Cupid on Horseback..... 387	An Acadian Basket Maker..... 390
	A Patriarch..... 388	A Five-Acre Dash..... 392
		389
AGRICULTURAL DISTRESS IN GREAT BRITAIN, THE.		P. T. Quinn..... 61
ANIMALS, HOW, GET HOME.		Ernest Ingersoll..... 90
ARMS AND AMMUNITION, AMERICAN.		William C. Church..... 436
Illus.	Breech Mechanism of the Remington Rifle. 439	Cross Section of Cartridge showing Interior. 448
	The Springfield System..... 439	The Peabody-Martini Cartridge..... 449
	The Sharps Rifle..... 440	Sharps or Remington Cartridge..... 449
	The Peabody-Martini..... 440	U. S. Government Cartridge..... 449
	The Gatling Machine Gun..... 441	Vernier Peep Sight..... 449
	Machine for Turning Stocks..... 442	Wind Sight and Spirit Level..... 449
	Barrel Rolls..... 445	Springfield Rear Sight..... 450
	Cuts Showing Progressive Changes in Bul- lets and the Old Paper Cartridge..... 446	The Lee Detachable Magazine Gun..... 450
	Cartridge of English Manufacture..... 448	The Winchester Magazine Gun..... 451
	Cartridge of American Manufacture..... 448	The Keene Magazine Gun..... 452
		The Hotchkiss Magazine Gun..... 452
ARTISTS' LIFE IN NEW YORK, YOUNG.		William H. Bishop..... 355
	Illustrations by the following members of the Salmagundi Club: W. A. Rogers, Walter Shirlaw, W. Taber, H. P. Wolcott, F. S. Church, S. G. McCutcheon, Will H. Low, H. P. Share, W. H. Shelton, M. J. Burns, Walter Clark, J. E. Kelly, George Inness, Jr., J. Lauber, J. S. Hartley, and others.	
Illus.	Off for Europe..... 356	An Artist in Rocks..... 362
	At "The Studio"..... 357	A Marine Artist's Studio..... 363
	The Artist in Black Eyes..... 357	"Decay" (Bass-Relief Sketch in Clay)..... 364
	Bargaining for a "Shanghai"..... 358	An Animal Artists' Studio..... 364
	A Discount to the Profession..... 359	The Illustrator Illustrated..... 365
	"Your Washing, Mum"..... 359	"Silence" (Eight Studies)..... 366
	The Salmagundi Club in Early Times..... 360	"Silence" (Bass-Relief Sketch in Clay)..... 367
	A Modern Meeting of the Salmagundi Club 361	"Silence" (Bass-Relief Sketch in Clay)..... 368
BICYCLING. (Illustrated.)	See "Hub, A Wheel Around the."	
BLACKBERRIES FOR HOME AND MARKET. (Illustrated.)	See "Fruits, Small, Success with."	
BRAZIL. (Illustrated.)	See "Coffee Culture in Brazil."	
BRIGHT, JOHN.		576
Illus.	Portrait of John Bright.....	576
CAPITOL OF NEW-YORK, THE.		Montgomery Schuyler..... 161
Illus.	Illustrations by R. Sayre, Francis Lathrop, W. M. Laffan, and others.	
	The "North Cente"..... 161	Assembly Chamber, West End..... 171
	Inside View of Window, Assembly Chamber 162	Plan of Assembly Chamber..... 172
	Outside View of Window, Old Plan..... 162	Under the Reporters' Gallery..... 172
	Dormer, Street Side..... 163	Cap of Large Column, Assembly Room... 173
	A Capital for a Street Dormer Window.... 164	Arch in the Lobby..... 173
	Dormer, Court Side..... 165	Fire-place. Griffin on Fire-place..... 174
	The Golden Corridor..... 166	A Clustered Pier..... 175
	Caps to Columns under Reporters' Gallery. 167	"The Discoverer." By W. M. Hunt..... 176
	The Court of Appeals Room..... 168	"The Flight of Night" By W. M. Hunt 176
	Staircase, New Capitol..... 169	Under the Ladies' Gallery..... 177
	Down the Staircase..... 170	A Dream of the New Albany..... 178
CAVERNS, INDIANA, EIGHTY MILES IN.		H. C. Hovey..... 875
	Illustrations by Julien Barton and W. L. Sheppard.	
Illus.	The Peri's Prison, Sibert's Cave..... 876	The Alligator..... 882
	A Perilous Pass, Sibert's Cave..... 876	The Pillared Palace..... 882
	Map of Wyandot Cave..... 877	Rothrock's Cathedral..... 883
	The Pillar of the Constitution..... 878	Slippery Hill..... 884
	A Colony of Bats, Wyandot Cave..... 880	Threading the Auger-Hole..... 885
	Calcite Crystals from Milroy's Temple..... 881	Milroy's Temple and Worm Alley..... 886
	A Specimen of Oulopholite..... 881	A Cave Flower..... 887
CHAM.		Richard Whiteing..... 741
	Illustrations, except the first, thirteenth and fifteenth, from Cham's published drawings, as credited in the text.	
Illus.	Cham..... 741	A Parisian..... 747
	M. de Lamartine as a Lightning-Conductor. 742	"M. Joseph Prudhomme," by Monnier... 748
	Louis Blanc in the Tribune..... 743	M. Prudhomme Saluting the Statue of the King of Prussia..... 749
	Louis Blanc "Lost in Sorrow"..... 743	Memorandum Sketch of Bridgeman's "Div- ersions of an Assyrian King"..... 750
	Pierre Leroux, Communist..... 744	Cham after Bridgeman..... 750
	M. Lamennais..... 744	"Do You Hunt, too?"..... 751
	M. Montalembert..... 745	Recollections of Youth..... 751
	Félix Pyat..... 745	Cham after Gérôme..... 752
	Hugo as an Orator..... 746	Matches of Clandestine Make..... 752
	M. Girardin, the Horace Greeley of France. 746	
	What is needed in the Assembly..... 747	

		PAGE.
COFFEE CULTURE IN BRAZIL.....		Herbert H. Smith..... 225
Illustrations by B. Wiegandt, W. L. Sheppard, Thomas Moran, and others.		
Illus.	Coffee Berries on the Tree..... 225	Picking Over Coffee..... 231
	Coffee Plantation in Southern Brazil..... 226	Sunday Morning..... 232
	The Viveiro..... 227	Cutting Cane-Stalks for the Cattle..... 232
	The Pulping-Machine..... 228	Road near Entre Rios..... 233
	Picking Coffee..... 229	Coffee Warehouse..... 236
	Steam Drying-Machine..... 229	Weighing..... 237
	Diagram of a Coffee Engenho..... 230	Wharf Scene at Rio de Janeiro..... 238
	Coffee Sheller (Old Style)..... 231	
CONFIDENCE. Chapters VII—XII. (Concluded.).....		Henry James, Jr. . .65, 209, 393
CURRANTS FOR HOME AND MARKET. (Illustrated.)		See "Fruits, Small, Success with."
EDISON'S ELECTRIC LIGHT. (Authoritative Account.).....		Francis R. Upton..... 531
Illus.	Autograph of Thomas A. Edison. (See frontispieces.)	Edison's Electric Lamp (Exact Size)..... 537
	Section of Edison's Expansion Regulator.. 533	Mercury Pumps for Producing Vacuums.. 538
	Edison's Pneumatic Regulator..... 533	Faradic Generator..... 539
	Foucault's Regulator..... 534	Proposed Central Station..... 540
	Effect of Carbon Arc Illumination..... 535	Diagram of Meter and System..... 541
	Effect of General Illumination..... 535	Edison's Electric Light Meter..... 541
	Edison's Vibrating Regulator..... 536	Edison's Electric Motor..... 542
	Edison's Platinum Lamp (Half Size)..... 537	Edison's Dynamometer..... 543
(See also p. 795.)		
FENCES, NEW ENGLAND.....		Rowland C. Robinson..... 502
Illustrations by Mary Hallock Foote, R. Riordan, F. H. Lungren, Will H. Low, and R. Blum, after sketches by the Author.		
Illus.	Post-and-Rail Fence..... 502	Old Half-Wall Fence..... 507
	Brush Fence..... 503	Over the Stump Fence..... 508
	Snake or Virginia Fence..... 504	Sawyer's Fence..... 509
	Log Fence..... 505	A Water Fence..... 510
	Board Fence..... 506	
FRUITS, SMALL, SUCCESS WITH. (Illustrated.).....		E. P. Roe. 9, 239, 338, 564, 753, 803
Illustrations by Mary Hallock Foote, R. Blum, W. H. Gibson, Jessie Curtis, Alfred Kappes, R. Riordan, W. L. Sheppard, W. Taber, and A. B. Frost.		
Illus.	"Ye boys that gather flowers and strawberries"..... 9	Making Crates..... 572
	The Home she might have had..... 10	Exterior of Factory..... 572
	Seeds and Pulp of the Strawberry..... 11	Some Baskets..... 573
	The Alpine Strawberry..... 11	Rushing the Last Lot..... 574
	Hautbois or Haarbeer Strawberry..... 11	Franconia and Belle de Fontenay Raspberries..... 753
	Indian Strawberry..... 12	Spring and Fall Plants..... 755
	Common Wild Strawberry..... 12	Winter Protection of Newly Set Plants..... 756
	Fragaria Chilensis..... 12	Right and Wrong Ways of Tying Canes..... 757
	A Gift of Strawberries..... 13	Storage Ground..... 758
	The Strawberry of Memory..... 16	Pruning and Laying Down Canes..... 758
	The "Seth Boyden" Strawberry..... 240	Antwerp Class of Raspberries..... 760
	The Scene of Operations..... 240	The Rush for the Night-Boat..... 761
	Clearing Land for Strawberries..... 241	The Approach of the Night-Boat..... 762
	Map Showing Experiments in Drainage..... 242	Native Raspberries of America (<i>Rubus Strigosus</i>)..... 764
	Men Ditching..... 245	Native Raspberries of America (<i>Rubus Occidentalis</i>)..... 765
	Jucunda Strawberry..... 245	Herstine Raspberry..... 804
	Tools for a Strawberry Farm..... 247	A Cool Packing-Place..... 804
	Counting and Mailing Plants..... 248	Gathering a Dainty Dish..... 805
	Potting Runners..... 339	Gathering Wild Blackberries..... 806
	Strawberry Blossoms..... 340	Kittatiny Blackberry..... 808
	Sharpless Seedling and Wild Strawberry..... 341	Cuthbert Raspberry..... 809
	A Row of Productive Crescent Seedlings..... 342	Nooning under the Trees..... 809
	A Cluster of Pioneer Strawberries..... 343	Wilson's Early Blackberry..... 811
	The Kentucky Seedling Strawberry..... 344	Pruning and Pruning-Shears..... 811
	The Charles Downing Strawberry..... 344	Snyder Blackberry..... 812
	Watering Plants in the Twilight..... 345	White Grape Currants..... 813
	The Monarch of the West Strawberry..... 345	In the Currant Field..... 814
	Wrong Methods of Planting..... 347	Weighing Currants..... 815
	The Proper Method..... 347	Late Emerald Gooseberry..... 816
	Root Pruning..... 347	"The Jelly wont Jell"..... 817
	The Wilson Berry..... 348	Currants and Gooseberries in Tree Form..... 819
	Boy Weeding..... 348	Currant Cuttings and Callus..... 820
	A Duchess Row and Berry..... 349	The Ideal Versailles Cluster..... 821
	Matted Bed System..... 351	Cherry Currants..... 821
	Narrow Row and Hill System..... 351	Houghton Seedling Gooseberry..... 824
	The Forest Rose Strawberry..... 352	Downing Gooseberry..... 824
	Cultivation by Horse-Power..... 352	Taking the Crates to the Evening Train..... 825
	Three Rows, illustrating Early Spring Work..... 353	White Dutch Currant..... 825
	The Home Field and Mr. Young's Cottage..... 565	Pickers' Head-quarters..... 828
	The First Glimpse..... 565	Packing for Market..... 829
	An Overseer: A "Little Brief Authority"..... 566	Picking Raspberries on the Hill-side..... 830
	Selling Cakes and Ice Water..... 567	Marlboro' Thirds..... 830
	"Git up, dar, yo' long man, off'n yo' knees"..... 567	Sunnyside Fruit-Box..... 830
	In from the Field..... 568	A Hap-hazard Hoe..... 831
	Exchanging and Counting Tickets..... 569	
	Paying Off Hands..... 570	
GOOSEBERRIES FOR HOME AND MARKET. (Illustrated.)		See "Fruits, Small, Success with."
GRANDISSIMES, THE. Chapters I—XXIX.....		George W. Cable..... 97 251, 369, 582, 690, 841
GRAYLING, THE MICHIGAN.....		Thaddeus Norris..... 17
Illustrations by James C. Beard, Thomas Moran, and W. M. Laffan.		
Illus.	The Michigan Grayling..... 17	Sweepers in the Au Sable..... 21
	View on the Manistee..... 20	Clear of the Sweepers..... 22

	PAGE.
HOPKINS, JOHNS, UNIVERSITY, THE.....	Sophie B. Herrick..... 199
Illus. Clifton, the Country Home of the Late Johns Hopkins..... 201 Entrance to the Grounds of Clifton..... 204 Instrument for Determining the Mechanical Equivalent of Heat..... 205	Johns Hopkins..... 205 D. C. Gilman, President of the Johns Hop- kins University..... 206 The Teacher's Class in Biology..... 208 Memorial Tablet in Hopkins Hall..... 208
HUB, A WHEEL AROUND THE.....	Charles E. Pratt..... 481
Illustrations by A. C. Redwood, L. Hopkins, Francis Lathrop, W. Taber, Robert Lewis, and F. S. Church.	
Illus. Recreation at Massapoag..... 481 Map of Bicycle Tracks..... 482, 483 The Meet, Roxbury..... 484 "Othello's Occupation 's Gone"...... 484 Pegasus Puzzled..... 485 The Old Curtis House..... 485 The Majesty of the Law..... 486 Impressions of Brook Farm..... 486 A Chapter of Headers..... 487 "A Merciful Man is Merciful to his Beast"...... 488 The Masher..... 488 Fairbanks Homestead, Dedham, Mass..... 489 Old Powder House..... 490	Passing a School..... 490 Picnic Lunch..... 491 An Unexpected Meeting..... 492 Roadside Sketches..... 493 Some Windows by the Way..... 494 Winners or Losers by Half a Length..... 494 The Dramatis Personæ..... 495 Halt to Catch Up..... 495 En Silhouette..... 496 Pan-dowdy..... 497 The Ambulance..... 497 On the Rocks at Cohasset..... 498 A Wheel Around the Hub..... 499
HUGO, VICTOR, TWO VISITS TO.....	Hjalmar Hjorth Boyesen..... 184
Illus. Victor Hugo (Engraved by T. Cole, from a photograph of the painting by Bonnat).....	184
ILKA ON THE HILL-TOP.....	Hjalmar Hjorth Boyesen..... 120
INDIANS. See "Wards of the United States Government, The."	
JETTIES, THE MISSISSIPPI. (Illustrated.) See "Mississippi Jetties, The."	
KANSAS CATTLE TOWN, A. See "Over Sunday in New Sharon."	
KANSAS FARMING, PICTURESQUE FEATURES OF.....	Henry King..... 132
KNIGHT OF DANNEBROG, A.....	Hjalmar Hjorth Boyesen..... 593
LAWN-TREES, RARE.....	Samuel Parsons, Jr..... 34
Illustrations by Charles A. Vanderhoof.	
Illus. The Double Flowering Cherry..... 35 The English Hawthorne..... 36 Cedar of Lebanon..... 37 Ginkgo Tree, Irish Yews, and Weeping Sophora..... 39 Dead Trunk of Weeping Sophora..... 40 Japanese Maple..... 41	Soulange's Magnolia..... 42 Chinese Cypress..... 43 Parson's Silver Fir, Weeping Norway Spruce, and Weeping Larch..... 44 Weeping Beech..... 45 Weeping Beech in Winter..... 45
LIFE-SAVING SERVICE, THE UNITED STATES.....	J. H. Merryman..... 321
Illustrations by M. J. Burns.	
Illus. Off to a Wreck..... 321 Life-Saving Station..... 322 Self-Righting Boat on Ways..... 322 Drill and Exercise in the Surf-Boat..... 323 Launching the Surf-Boat..... 324 The Night Patrol..... 325 Burning a Signal..... 326 Hauling the Mortar Car..... 328 Surfman with Life-Belt..... 329 Firing the Mortar..... 330 Breeches-Buoy Apparatus in Operation..... 331	"Haul away"..... 331 The Breeches Buoy..... 332 The Self-Righting Life-Boat..... 333 The Self-Righting Life-Boat Under Sail..... 334 Life-Saving Dress..... 335 Tally-Board and Whip-Block..... 335 Resuscitation: Ejecting Water from Body..... 336 Resuscitation: Restoring Respiration..... 336 The Mess-Room..... 337 Medicine Chest, Lanterns, etc..... 337
LOUISIANA. Chapters I—XIV.....	Frances Hodgson Burnett..... 512
Illustrations by Mary Hallock Foote.	672, 832
Illus. "Walk across the floor," commanded Miss Ferrol..... 512	"Ask your sister," she replied; "it was her plan"..... 672 "She waited in vain"..... 832
MICHELET, JULES.....	J. D. Osborne..... 888
Illus. Portrait of Jules Michelet.....	888
MISSISSIPPI JETTIES, THE.....	E. L. Corthell..... 46
Illustrations by A. C. Redwood and others.	
Illus. Delta of the Mississippi River..... 46 Work-Shops, Derrick, Dredge, and Jetty Tug, Port Eads..... 47 Looking out to Jetties from Port Eads..... 47 Port Eads from West Jetty Concrete Wharf..... 47 Section of Jetty 11,100 feet from Land's End..... 56 Section of Jetty 7,500 feet from Land's End..... 56	Captain James B. Eads..... 48 Bird's-eye View of the Jetties..... 49 Head of Passes..... 53 Section of Jetty 11,100 feet from Land's End..... 56 Section of Jetty 7,500 feet from Land's End..... 56
MOORE, MR. MORRIS, AND HIS OLD MASTERS.....	Clarence Cook..... 24
Illus. Raphael's "Apollo and Marsyas"..... 24 Original Sketch for the "Apollo and Marsyas"..... 25	Michael Angelo's "Virgin of the Lactern."..... 33
MULES, ROCKY MOUNTAIN.....	Ernest Ingersoll..... 929
Illustrations by W. Taber.	
Illus. The Riding Animals..... 929 Ready to be Packed..... 931 Sinching Aparejos..... 932 "All set"..... 932	"Give it to her"..... 933 A Sensation..... 934 Laboring under a Delusion..... 936
NAPOLEON, TWO VIEWS OF.....	711
NATURE AND THE POETS.....	John Burroughs..... 285
NEW YORK, THE FRENCH QUARTER OF.....	William H. Rideing..... 1
Illustrations by R. Blum, J. H. Twachtman, Douglas Volk, Will H. Low, and J. Alden Weir	
Illus. Tin-Shop in Greene Street..... 1 Basement Grocery in Houston Street..... 1 Restaurant du Grand Vatel in Bleecker St..... 2 Landlady of the "Grand Vatel" and her Parrots..... 3	French Bakery in Greene Street..... 4 Taverne Alsacienne, Inside and Out..... 5 Making Artificial Leaves..... 6 The Cook of the Grand Vatel..... 8 Tail-piece..... 9

	PAGE.
NOTES OF A WALKER.....	<i>John Burroughs</i> 608, 684
ORCHESTRA OF TO-DAY, THE.....	<i>Sidney Lanier</i> 897
OVER SUNDAY IN NEW SHARON.....	<i>Henry King</i> 768
PARIS, ODDITIES OF.....	<i>J. D. Osborne</i> 296
"PERSONAL," A, AND WHAT CAME OF IT.....	<i>Barbour T. Lathrop</i> 453
PETER THE GREAT. Chapters I—XII.....	<i>Eugene Schuyler</i> .. 545, 721, 905
Illustrations by Schwartz, Francis Lathrop, Charlemagne, N. Dmitrieff, Maurice Howard, R. Sayre, and others.	
Illus. Portrait of Peter the Great..... Frontispiece	
Tsar Alexis, Father of Peter the Great..... 545	
Tsaritsa Natalia, Mother of Peter the Great..... 546	
Russian Hospitality during the time of Ivan the Terrible..... 547	
The Kremlin, Moscow..... 548	
A Group of Boyars..... 549	
Peter, the Metropolitan of Moscow..... 550	
The Great Bell of the Tower of Ivan Veliki..... 553	
A Religious Ceremony in Moscow in the 17th Century..... 554	
Russian Arms before the Time of Peter..... 555	
Terem, or Women's Apartment..... 557	
Murder of Dimitri, son of Ivan the Terrible..... 560	
Tsar Theodore (Half-Brother of Peter)..... 561	
Tsarevitch Joann or Ivan (Half-Brother of Peter)..... 561	
A Cossack Conqueror..... 721	
St. Vladimir, Sovereign of Russia, A. D. 981..... 722	
Introduction of Christianity into Russia..... 723	
Russian Irregular Cavalry (16th Century)..... 724	
Ivan the Terrible in Old Age..... 725	
Arm-ed Russian on Horse (16th Century)..... 726	
Arm-piece and Shield in One Piece (Middle 17th Century)..... 727	
Russian Irregular Cavalry, Armor of Wadded Cloth (14th to 17th Century)..... 727	
Helmets of Wadded Cloth (14th to second half of 17th Century)..... 727	
POLITICAL OUTLOOK, THE.....	<i>E. L. Godkin</i> 613
RASPBERRIES FOR HOME AND MARKET. (Illustrated.) See "Fruits, Small, Success with."	
Illustrations by W. H. Gibson, Alfred Kappes, R. Riordan, and W. Taber.	
RAYMOND, HENRY J., EXTRACTS FROM THE JOURNAL OF. Edited by his Son.....	<i>Henry W. Raymond</i> .. 57, 419, 793
REVOLUTIONARY CONGRESSMAN ON HORSEBACK, A.....	<i>Thomas Wentworth Higginson</i> 412
SALMAGUNDI SKETCH CLUB, THE. See "Artists' Life in New-York, Young."	
SIGH, A.....	<i>Elizabeth A. Read</i> 110
STRAWBERRIES FOR HOME AND MARKET. (Illustrated.) See "Fruits, Small, Success with."	
STRAWBERRY FARM, A SOUTHERN. (Illustrated.) See "Fruits, Small, Success with."	
SUMMER'S DIVERSION, A.....	<i>Julia Schayer</i> 921
SUNDAY-SCHOOL WORK, PRESENT PHASES OF.....	<i>Edward Eggleston</i> 524
TAYLOR, BAYARD: HIS POETRY AND LITERARY CAREER.....	<i>Edmund C. Stedman</i> .. 81, 266
(See also Frontispieces.)	
THRIZA.....	<i>Julia Schayer</i> 425
TILE CLUB AFLOAT, THE.....	{ <i>W. McKay Laffan</i> } { <i>Edward Strahan</i> } 641
Illustrations by W. M. Laffan, J. H. Twachtman, F. Hopkinson Smith, C. S. Reinhart, J. Alden Weir, E. A. Abbey, W. M. Chase, F. Dielman, A. Quartley, R. Swain Gifford, N. Sarony, and W. R. O'Donovan.	
Illus. In the Mist of the Early Morning..... 641	
At the Dock, Foot of West Tenth Street..... 642	
Decoration of the Salon, 1879..... 643	
The Community Afloat..... 644	
Daniel in the Tilers' Den..... 645	
Deuteronomy..... 646	
A Daughter of the Tow..... 646	
Reflections of an Absent Tiler..... 648	
Priam, the Nubian Ganymede..... 649	
The Home Circle..... 651	
Posing on Deck..... 652	
Parting Company with the Tow at West Troy..... 653	
Jessie Miller..... 653	
A Tow-Girl..... 654	
A Visit from the Bumboat, near Troy..... 654	
A Lock near Troy..... 655	
Art Criticism at Weaver's Basin..... 656	
Shadow-Painting..... 657	
A Decorative Notion..... 658	
Under the Willows..... 658	
The Marine..... 659	
A Pang in Black and White..... 659	
Only Prepossessing View of the Owl..... 660	
Prowlings of the Owl..... 660	
A Bit of Schuylerville..... 661	
Nice Girl in an Old Chair..... 662	
Spirit of a Normandy Day..... 663	
Dampness on the Tow-path..... 663	
A Diversion in Payne's Grey..... 664	
A Successful Sketch..... 664	
"And things are not what they seem"..... 665	
"Come to the Sunset Tree"..... 666	
North End of Salon, 1879..... 667	
The Tile Bakery..... 668	
A Tile Baker..... 668	
The Lock-Keeper's Daughter..... 669	
Considerations of Sadness..... 670	
Phileas's Sweetheart..... 670	
Coming Home..... 671	
UNDER HIGH PRESSURE.....	<i>Charles Barnard</i> 276
WARDS OF THE UNITED STATES GOVERNMENT, THE.....	<i>H. H.</i> 775

WOOD-CUT PRINTING, THE GROWTH OF.....	<i>Theodore L. De Vinne</i>	860
ILLUS.		
Engraved Initial Letter and Movable Types of the Mentz Psalter.....		860
A Section from one of Burgmair's Prints of "The Triumph of Maximilian".....		861
The Apocalypse, drawn by Albert Dürer.....		862
Types of the "Speculum Salutis".....		863
Old Engraving in Outline.....		863
Early Roman Types of Light Face.....		863
Page from a book of "Hours," printed on Vellum, by Simon Vostre, 1512.....		864
The Hand-Press of the Sixteenth Century.....		865
Old English Printing-Office.....		866
Engraving on Wood.....		867
Device of Thielman Kerver.....		867
Device of Christopher Plantin, "King of Printers".....		868
Old French Printing-Office.....		868
The Woodlark, Engraved by Bewick.....		869
Wood-Frame Hand-Press of 1800.....		870
The Stanhope Press.....		871
A Section of Harvey's Engraving of the "Assassination of Dentatus".....		873
The Columbian Press.....		874

POETRY.

ADVENT.....	<i>Marie Mason</i>	194	
APRIL.....	<i>W. P. Foster</i>	920	
BOOZY LITTLE BAT.....	<i>Charles de Kay</i>	500	
	Illustrations by Alfred Kappes.....		
BROTHER ANTONIO.....	<i>Elizabeth Akers Allen</i>	178	
	Illustrations by R. Blum.....		
ILLUS.			
"In vain he struggled against their might".....	180	"Chill and silent the dead monk lay".....	181
"Little he cared for specters grim".....	181		
BY THE HEARTH.....	<i>Elizabeth Stuart Phelps</i>	194	
COR CORDIUM.....	<i>Henry Terrell</i>	424	
DWELLING-PLACES.....	<i>Thomas Wentworth Higginson</i>	767	
FRA LUIGI'S MARRIAGE.....	<i>H. H.</i>	801	
	Illustration by Robert Blum.....		
ILLUS.			
"The man is dead," he said".....	801		
FROST PICTURES.....	<i>Alice Williams Brotherton</i>	198	
GALATEA.....	<i>Eliza C. Hall</i>	34	
GIFTS.....	<i>M. T. H.</i>	767	
GOOD-BYE, SWEET DAY.....	<i>Celia Thaxter</i>	194	
GRASS-WORLD, THE.....	<i>Mary Mapes Dodge</i>	196	
HYMN TO THE SEA.....	<i>Richard Henry Stoddard</i>	458	
IN CONFIDENCE.....	<i>Mary J. Jacques</i>	23	
INDIAN PIPE.....	<i>Elaine Goodale</i>	198	
IN THE ADIRONDACKS.....	<i>Anne Lynch Botta</i>	197	
INVITATION, AN.....	<i>Violet Hunt</i>	897	
JUST OUT OF SIGHT.....	<i>H. H.</i>	197	
KING'S LESSON, THE.....	<i>Mary Bradley</i>	196	
LOVER'S ANSWER, THE.....	<i>Ella Dietz</i>	782	
MADONNA OF FRA LIPPO LIPPI, A.....	<i>Richard Watson Gilder</i>	411	
MARY'S EASTER.....	<i>Marie Mason</i>	831	
MIDWINTER FLOWERS. (To E. C. S.).....	<i>Louise Chandler Moulton</i>	195	
ODE TO DROWSINESS.....	<i>Charles G. D. Roberts</i>	140	
ONLY CHOICE, THE.....	<i>Frances Louisa Bushnell</i>	197	
POET'S ANSWER, THE.....	<i>Margaret J. Preston</i>	196	
PORTO FINO.....	<i>Richard Watson Gilder</i>	592	
PROPHECY.....	<i>Harriet McEwen Kimball</i>	195	
REMEMBERED TEACHER, A.....	<i>William Cleaver Wilkinson</i>	581	
RYDAL WATER.....	<i>Annie R. Annan</i>	195	
SAINT SYMPHORIEN.....	<i>Rose Terry Cooke</i>	195	
SONNETS IN MEMORIAM OF THE LATE PRINCE IMPERIAL.....	<i>William C. Bonaparte Wyse</i>	131	
SPIDER'S LESSON, THE.....	<i>Julia Ward Howe</i>	418	
STARS, THE.....	<i>Mary Mapes Dodge</i>	119	
SUMMER IN WINTER.....	<i>Dora Read Goodale</i>	896	
TAMING OF THE FALCON, THE.....	<i>Emma Lazarus</i>	196	
"THAT LASS O' LOWRIE'S".....	<i>Marie Mason</i>	544	
THEIR ANGELS.....	<i>Adeline D. T. Whitney</i>	197	
THEOCRITUS, FOR A TRANSLATION OF.....	<i>Austin Dobson</i>	96	
TORNADO, THE.....	<i>Charles de Kay</i>	936	
TO SORROW.....	<i>Julie K. Wetherill</i>	435	
TRANSFIGURED.....	<i>S. M. B. Pratt</i>	195	
TRYST, THE.....	<i>Elizabeth Stoddard</i>	198	
UNATTAINED.....	<i>Nora Perry</i>	196	
VALENTINE, A.....	<i>Laura Winthrop Johnson</i>	593	
VILLAGE CHURCH, THE.....	<i>E. D. R. Bianciardi</i>	859	
VITA NUOVA.....	<i>Anne Lynch Botta</i>	671	
VITTORIA.....	<i>Elizabeth Stuart Phelps</i>	710	
WAITING FOR WINTER.....	<i>Henry A. Beers</i>	265	
WHIP-POOR-WILL.....	<i>Mary Mapes Dodge</i>	119	
YOUTH TO THE POET. (To Oliver Wendell Holmes).....	<i>George Parsons Lathrop</i>	740	

DEPARTMENTS.

TOPICS OF THE TIME :

"The Reign of Peter the Great"—"Is Life Worth Living?"—The Nation's Doctors, 142; Sunday Bumpers—Teachers and Task-masters—The Sermon, 302; British and American Farming—From Country to City—Fiat Money, 461; A Word on Politics—Temperance Education—Familiarity, 621; The Purchase of Pictures: A Proposition—The Revision of the Scriptures—Industrial Education, 783; A Lay Sermon for Easter—A Profitable Art Industry; An Offer of Premiums, 937.

COMMUNICATIONS :

"The Infant Hercules" again (*Sofia Bompiani*), 144; An Objection to English Spelling Reform (*N. L.*), with a reply from *Mr. Lounsbury*, 465; The Restoration of St. Mark's (*R. W. G.*), 624; "Edison's Electric Light" (a reply from *Albon Man*), 795; The First Breech-loading Rifle (with three cuts by *H. W. Troy*) (*J. Watts de Peyster*), 939.

HOME AND SOCIETY :

Light, Heat and Power for the Householder (*Charles Barnard*)—Weaning the Baby (*Catherine Owen*), 145; General Principles of Cookery, I.: Boiling (*Catherine Owen*)—The Boys of the Family, VI.: How to become a Telegrapher, an Engraver, and an Architect (*William H. Rideing*) 305; General Principles of Cookery, II.: Stewing and Making Soups (*Catherine Owen*)—Two Kinds of Decoration (*M. L. E.*), 465; General Principles of Cookery, III.: Roasting (*Catherine Owen*)—Flour from Chestnuts (*J. Schuyler Crosby*), 625; City Shopping for Country Friends (*S. B. H.*)—The Plague of Formal Calls (*M. G. van Rensselaer*)—General Principles of Cookery, IV.: Frying and Broiling (*Catherine Owen*), 786; Operas for Amateurs (*M. L. E.*), 941.

CULTURE AND PROGRESS :

Haeckel's "Evolution of Man"—Mrs. Burnett's "Haworth's"—Bartlett's "From Egypt to Palestine"—Mrs. Dorr's "Friar Anselmo and Other Poems"—A New Translation of the *Odyssey*—Dickens's "Life of Charles James Matthews," 149; "A Portfolio of Proof Impressions" from SCRIBNER and ST. NICHOLAS—Joyce's "Bland"—Baird's "Rise of the Huguenots"—Leland's "Life of Lincoln"—Jules Verne's "Exploration of the World"—Yriarte's "Venice"—Some Recent Books for Children, 309; Arnold's "Light of Asia"—"The Letters of Charles Dickens"—Taylor's "Studies in German Literature"—Farrar's "Life of St. Paul"—Bret Harte's "Twins of Table Mountain"—Miss Phelps's "Sealed Orders"—"An Earnest Trifler"—Guernsey's "Thomas Carlyle"—Abbott on John, 468; "Harper's Latin Dictionary"—Two Volumes of "L'Art"—"Souvenirs of Madame Vigée Le Brun"—"The Amateur Poacher"—Johnston's "History of American Politics"—Rousslet's "Serpent-Charmer"—"Her Lover's Friend," by Nora Perry—"Dramatic Persons and Moods," by S. M. B. Piatt—"Along the Way," by Mary Mapes Dodge—"In Berkshire with the Wild Flowers," by Elaine and Doris Goodale—"Risk, and Other Poems," by Charlotte F. Bates, 629; Woolsey's "Communism and Socialism"—Gosse's "New Poems"—"His Majesty, Myself"—Higginson's "Short Studies of American Authors"—Linton's "Hints on Wood-Engraving"—Smith's "Brazil"—The School Experiment at Quincy, 789; James's "Hawthorne"—Julian Hawthorne's "Sebastian Strom."—Austin Dobson's Poems—Dr. Wines and his Last Work—Gardner's "Common Sense in Church-Building"—Du Maurier's "English Society at Home"—The Fourth Quarterly of "L'Art" (1879)—Champlin's "Child's Catechism of Common Things" (illus.), 943.

THE WORLD'S WORK :

Important Advance in Metallurgy—Improved Builder's Platform—Novel Application of the Pendulum to Useful Work—Memoranda, 155; New Stage for Theaters—Influence of Time on Stress—Book-sewing Machine—New Faradic Machine—Calculating Attachments for Weighing Scales—Fire-screen for Forges—Palmeline—Sanitas, 316; New Drawing Apparatus—New Tube-Cleaner—Steam Pavement-Rammer—Electric Balance—New Uses for the Flexible Shaft—New Method of Obtaining a Temporary Blast—Memoranda, 475; New Fruit Press—Bridge Building—Etching Metals—Glass Sleepers—The Audiphone—The Steering Screw—Mechanical Extraction of Cream—Novel Photo-Printing Process—Simple Electrical Signal, 636; Novel Arrangement of the Interior of a Theater (illustrated by *Francis Lathrop*), 796; Progress in Electric Lighting—Dynamo-Electric Machines in Telegraphy—Improved Refrigerating Process—Experiments with Blast—A New Form of Air-Injector—A New Globe for Schools, 950.

BRIC-À-BRAC :

Love-Song (*W. M. Briggs*)—Rev. Biddlecomb Ingersoll Vindicates himself (*David S. Foster*)—The Lory-Lye (A New Translation)—A Microscopic Serenade (*Jacob F. Henrick*), with Drawing by *F. H. Lungen*—"The Wall of the "Personally Conducted" (*H. C. Bunner*)—Ballad of Blue China (*Andrew Lang*), 157; Sweet and Low—American Books on the Paris Quays—Wanted: A Minister—Specimen Bricks from the Dictionary of the Future—In the Art Gallery (drawing by *Gustav A. Endlich*)—A Lesson in Mythology (*Eliza C. Hall*)—Personal—Political—In November (*L. Frank Tooker*), 318; The Star (*W. P. Peters*)—Dictation Exercises (*Virginia S. India*)—Les Morts Vont Vite (*J. B. M.*)—A Reply to "Speaking Features" (*P. C. S.*)—Song (*William M. Briggs*)—Epigrams (*George Birdseye*)—Is Life Worth Living? (*G. J. A.*), 477; The Beggar's Mirror (*Joel Benton*)—The Polyphone (*Irwin Russell*)—Design for Bicycle's Handkerchief (*By L. Hopkins*)—An American Sketch (*N. G. Cone*)—Beside Love's Bier (*R. T. W. Duke, Jr.*)—Epigrams (*C. H. Dennis*)—From a Counting-House (*H. C. Bunner*), 639; Verses by Irwin Russell (Rev. Henry's War Song—The Romant of Sir Kuss—Cosmos—An Exchange)—To Irwin Russell (*H. C. Bunner*)—reprinted from "Puck"—Shakespeare in Italian—Poetical Amities (*Austin Dobson* and *E. C. Siedman*), 798; The Princes' Noses (*W. J. Linton*)—An International Episode (*Eliza C. Hall*).

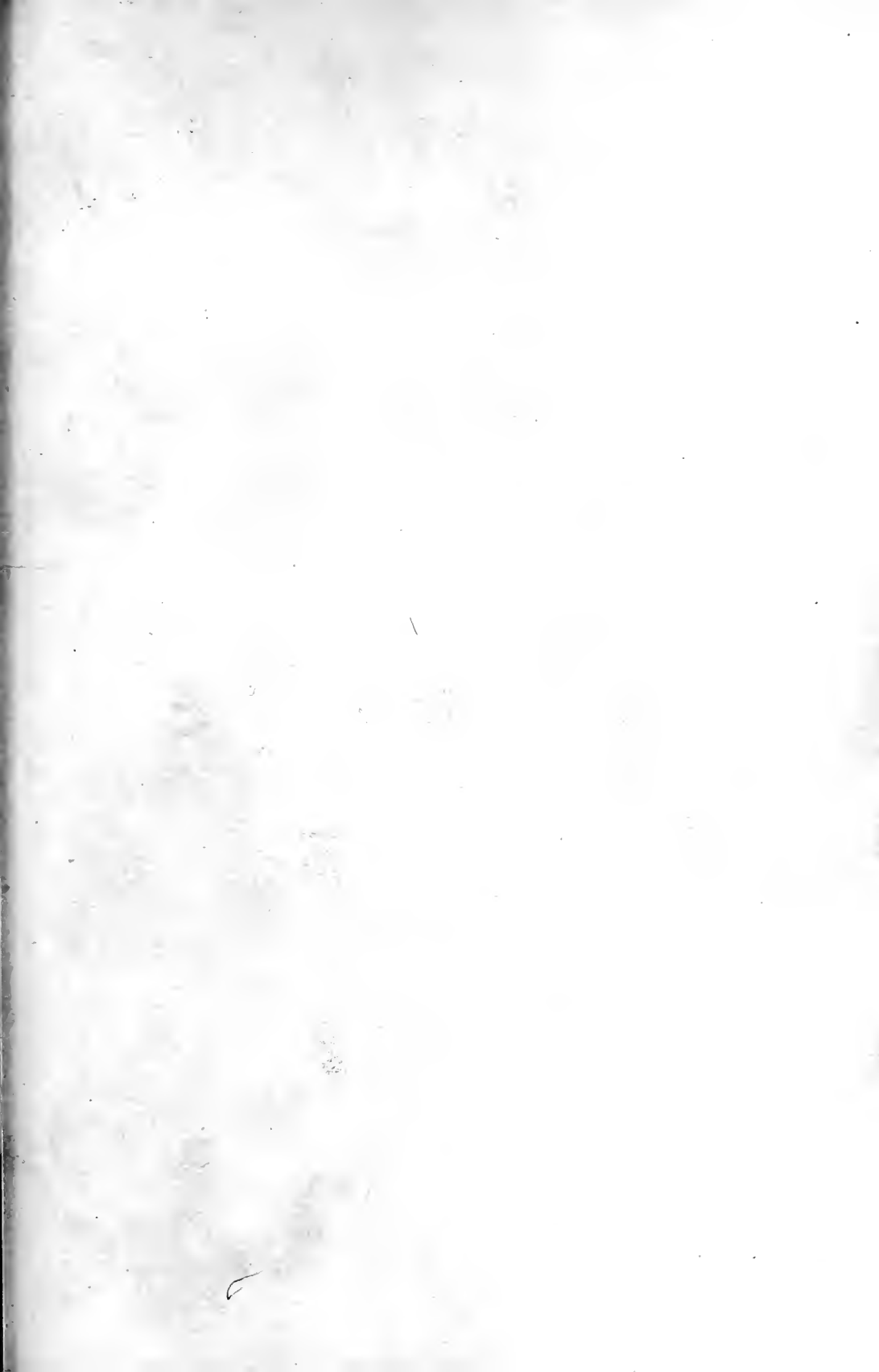



Bedouin Song.

From the Desert I come to thee,
On a stallion shod with fire,
And the winds are left behind
In the speed of my desire.
Under thy window I stand,
And the midnight hears my cry:
I love thee, I love but thee,
With a love that never shall die,
Till the sun grows cold,
And the stars are old,
And the leaves of the Judgment Book
unfolds!

Oct. 29, 1853.

Bayard Taylor.

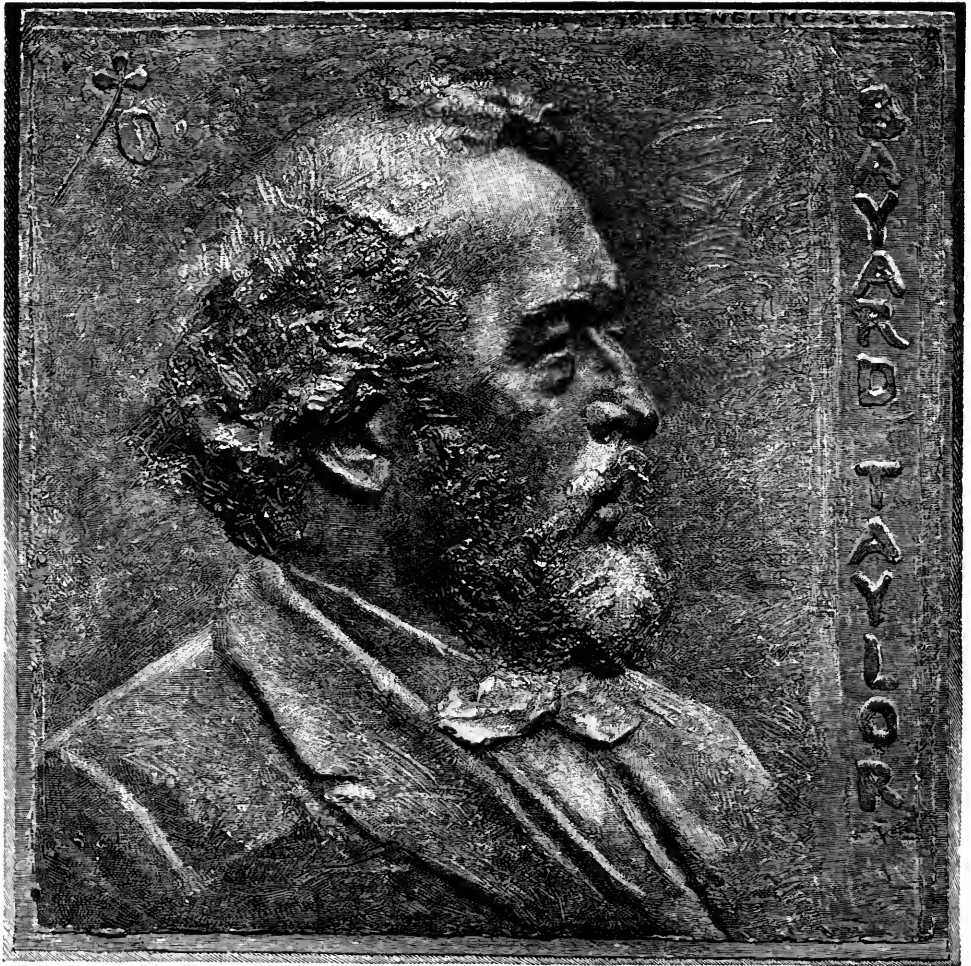

SCRIBNER'S MONTHLY.

VOL. XIX.

NOVEMBER, 1879.

No. 1.

THE FRENCH QUARTER OF NEW YORK.

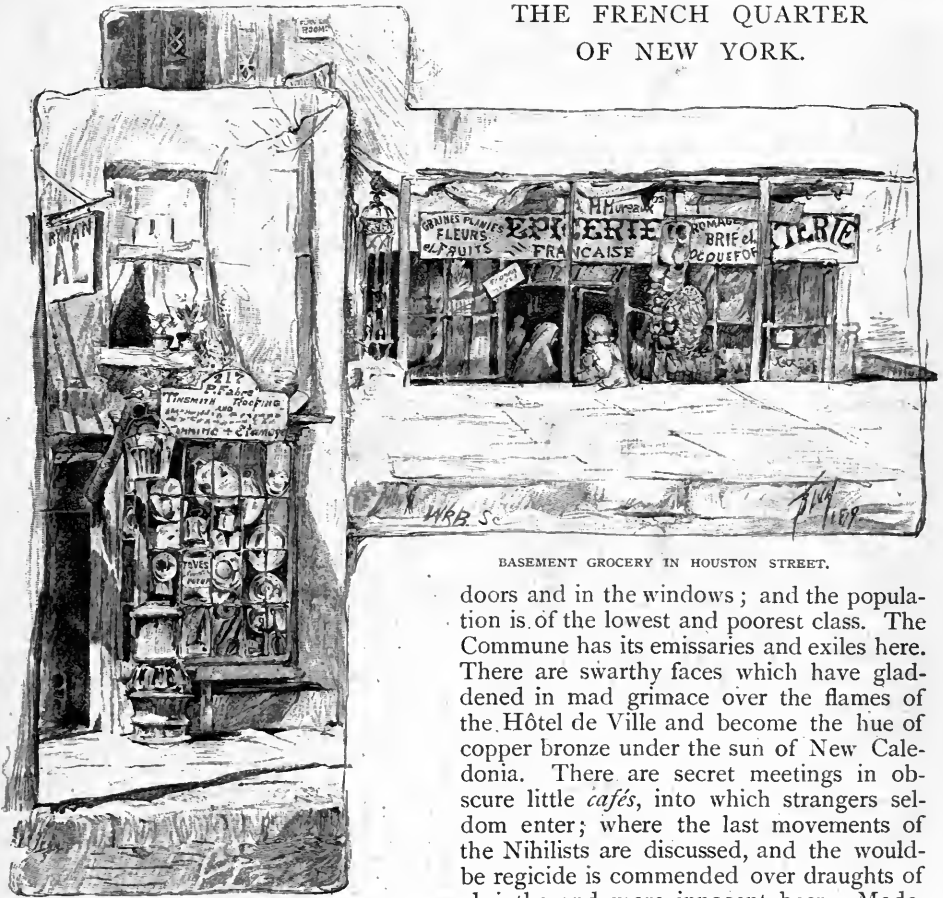

TIN-SHOP IN GREENE STREET.

BASEMENT GROCERY IN HOUSTON STREET.

I CONFESS to finding no little pleasure in lazy explorations of the region that lies west of Broadway, south of Washington Square, and north of Grand street. This is the *Quartier Français* of New York. The commonplace, heterogeneous style of the buildings, and the unswerving rectangular course of the streets are American, but the people are nearly all French. French, too, is the language of the signs over the

doors and in the windows; and the population is of the lowest and poorest class. The Commune has its emissaries and exiles here. There are swarthy faces which have gladdened in mad grimace over the flames of the Hôtel de Ville and become the hue of copper bronze under the sun of New Caledonia. There are secret meetings in obscure little *cafés*, into which strangers seldom enter; where the last movements of the Nihilists are discussed, and the would-be regicide is commended over draughts of absinthe and more innocent beer. Mademoiselle Berthe, with her little sisters, fabricates roses and violets out of muslin and wax in the high attics of the tenement houses. Madame Lange, with her arms and neck exposed, may be seen ironing snowy linen in front of an open window. Here is Triquet, *le charcutier*; Roux, *le bottier*; Malvaision, *le marchand de vin*; Givac, *le charcutier Alsacien*, and innumerable basement restaurants, where dinner, *vin compris*, may be had for the veriest trifle.

The brazen faces of idle and vicious women stare out of the half-closed lattices at the passer-by, and there are shady alleys, unsafe to the stranger unattended; but

of the room were partly concealed by the long, loaded shelves. There was a perplexingly mixed quantity of small-wares, kindling wood, herrings, leather, groceries,

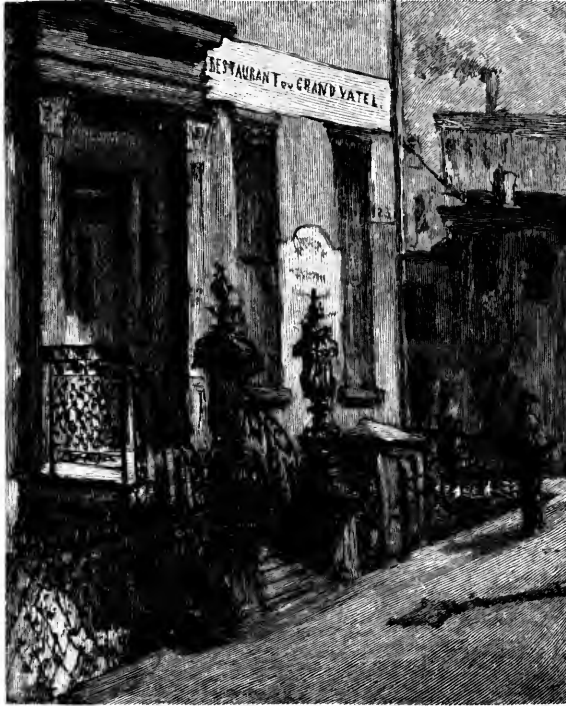

RESTAURANT DU GRAND VATEL IN BLEECKER STREET.

the denizens of the quarter are mostly industrious, thrifty and honest. They earn little and spend less. They talk French, and retain many of the customs of the motherland. It is notable how insular and exclusive they are; for Broadway, with its assimilative influence, is the eastern limit of the district.

Turning down Grand street into Greene one day, with half a dozen steps my friend and I were transported in imagination to France. At No. 95 we descended into a basement, the specialties of which were indicated by the sign over the door: "Sabots et Galoches—Chaussons de Strasbourg," but the specialties were not immediately visible in an abundance of the varied merchandise of a general store. The small panes in the window were not made to admit an abundance of light, and that which would have come in was obstructed by the sample articles displayed along the sashes. The roof was low, the counter wide and the proportions

and other preparations, the wrappers of which bore the marks of French exportation. Probably the neighbors had no alimentary want that could not have been satisfied out of the multiplicitous stock. The delicate drab pots of *pâté de foie gras* were visible among much grosser articles of plebeian diet; but despite the array of wares and the sufficiency, no customer was there when we entered, and none came in while we remained. A bell attached to a spring over the door tinkled violently to announce us and subsided with a nervous quiver. All was so quiet and antique in the little store that we dreamily thought of Miss Hepzibah Pyncheon, and half expected to see her come out of the inner room, which was open to inspection through a windowed door. But instead of the tall, angular, forbidding shop-keeper of Salem, a courtly old lady issued forth in a white Normandy cap, and saluted us with a charmingly dignified courtesy: "*Bon jour, Messieurs.*" She was

old and white-haired, but her manners and face had a lavender-like reminiscence of the queen of a long-ago *rosière*. That was a fancy of my friend's, who asked to see some *sabots*. "Ah, oui!" said Madame, and suspecting that customers so unusual as we were could only want them for private theatricals, or, perhaps, a fancy dress ball, she brought out of a recess a pair with red tops and a garniture of bright-headed nails. My friend shook his head; we wanted the real *sabots des paysans*, and she laughed at the idea as she showed us a pair of the coarse wooden shoes with stiff uppers that may be seen on the feet of the plodders in agricultural France. She told us that there was very little demand for them; that they cost a great deal to import, and that the lowest price at which she could sell them was seventy-five cents! They did not seem dear, and my friend, who is an artist, bought them in expectation of finding a future use for them in one of his pictures. "We make smaller ones to order," Madame told him. He replied he might require a pair, and when she inquired about the size and

he exhibited his hand, she laughed again, and perhaps thought of the *rosière* with whom he had associated her. "Ah, yes," she answered, "but ladies always wear them padded with cotton wool." We then asked her for one of her business cards. "It is quite unnecessary, *messieurs*," she remarked: "I am known all over the *quartier*." This was said with a delicious air of mock dignity and another profound courtesy. Through the glass-door separating it from the shop, we could see into the further room, where by the light of a strong lamp a man was putting together the parts of some delicate machinery; and this was Madame's husband, who adds to the profits of the store his earnings as a watch-maker. The humble scene was so essentially foreign that, having said "*Bon jour*" to Madame, we went into the street with more than three thousand miles of distance imagined between us and our actual situation. Just then, too, while the bell over the door was still audible in dying pulsations, a man brushed past us with a bristling crop of black hair, a coarse black mustache, small black eyes, and a sallow



LANDLADY OF THE "GRAND VATEL" AND HER FARROTS.



FRENCH BAKERY IN GREENE STREET.

complexion ; he wore a blue blouse, and carried his hands in his pockets ; this surely was Jacques, unalienated from the idle crowds around the wine-shops of Belleville.

While, as we have said, most of the people in the quarter are of the industrial or criminal classes, there is also a scattering of impecunious music-teachers and professors of languages, who maintain themselves with a frosty air of shabby-gentility on a very, very slender income. Literature and art have devotees in a peculiar condition of allied mental exaltation and bodily penury domiciled in the dismal-looking houses, over the doors of which a sign proclaims "Chambres Meublées et Pension,"—men whose lives have no fruition, and whose occupations do not embitter them by their futility, but are held in higher esteem than by much more successful votaries. After his unprofitable labor of the day, the poor professor repairs to a restaurant, where he sits down to a dinner of five or six courses ; he bows profoundly to the landlady, who is cordial or severe in her recognition according to the items on the little slate which records her accounts ; he waves his hand airily to

some acquaintance, and leisurely begins his meal. He has *soupe aux croûtons*, *veau à la Marengo*, *pommes frites*, a small portion of *Gruyère* and a bottle of wine. He eats appreciatively after the manner of a *bon vivant* ; he uses his napkin gently and frequently ; he glances blandly at the surroundings ; watching him, you would suppose the viands were the choicest of the season, exquisitely prepared, while in reality they are poor and unsubstantial stuff, the refuse, perhaps, of better restaurants. Having finished the edibles, he calls for a "gloria," that is, black coffee and cognac, and sipping this, he communes with his fancies which come and vanish in the blue waves of cigarette smoke. His aspect bespeaks perfect complacency—"Fate cannot harm me ; I have dined today." It is the happy knack of his kind and country to extract the fullest enjoyment from the least considerable materials, and he returns to his attic, or seeks some *café* for the rest of the evening, in a mood of blissful contentment.

It is in the restaurants and *cafés* of the region that we learn the frugality of the denizens. Here in Bleecker street, at the

corner of an intersecting thoroughfare, is the "Restaurant du Grand Vatel," named after the celebrated and heroic cook of Louis the Fourteenth, who, utterly chagrined at the failure of a certain fish to arrive in time for one of his dinners, ended his life by running a sword through his body. The sign of this restaurant indicates an exceedingly moderate tariff, thus: *Tous les plats*, eight cents; *plats extra variés*; *café supérieur*, three cents, and *café au lait*, five cents; but the *menu* is such a marvel that it is worth reproducing. A dish of soup and a plate of beef and bread are ten cents; *soupe aux crouillons*, that is, with toasted crusts, costs five cents; *bœuf, légumes*, ten cents; *veau à la Marengo*, twelve cents; *mouton à la Ravigotte*, ten cents; *ragout de moutons aux pommes*, eight cents; *bœuf braisé aux oignons*, ten cents; *macaroni au gratin*, six cents; *celeri salade*, six cents; *compote de pommes*, four cents; *fromage Neufchâtel*, three cents; *Limbourg*, four cents, and *Gruyère* three cents. Bread is one cent extra. Think how far fifty cents will go in so reasonable an establishment! The professor's dinner, wine included, costs him the extravagant sum of forty cents, and with five cents added for a roll and a cup of coffee in the morning, that sum covers his daily expenditure for food.

The floor is sanded, and the little tables are covered with oil-cloth, each having a

pewter cruet in the center. A placard flutters from the wall, announcing a grand festival, banquet, ball and artistic tombola in celebration of the eighth anniversary of the bloody revolution of March 18th, 1871, under the auspices of the "Société des Réfugiés de la Commune,"—"Family tickets, twenty-five cents; hat-room checks, ten cents"—from which we gather that the "Restaurant du Grand Vatel" has some queer patrons. The landlady sits behind a little desk in a corner. She is a woman of enormous girth, with short petticoats which reveal her thick, white woolen socks; her complexion is dark, her eyes are black and deep, and large golden rings dangle from her ears. A little man with red hair, and loose, slovenly slippers, who shuffles untidily about, is Leroy, *le propriétaire*. Two revolutionary parrots are perched over Madame's head, and break the silence by their horrid cries. "Tranquille!" cries she, tapping them with a cane, and they remain quiet for a few minutes, to resume their shrieks until she again admonishes them. No customers are present, and the *cuisinier* is staring idly out of the window. His hands and arms are very dirty, but his head is crowned by a *toque* of unsurpassable whiteness. The *garçon* also is unoccupied, and stares wonderingly at my friend and me, who are trying a six-cent dish of *macaroni au gratin*, which proves to be not altogether unpalatable. By and by a faded little gentleman enters, whom we at once recognize as one of those incommunicable acquaint-

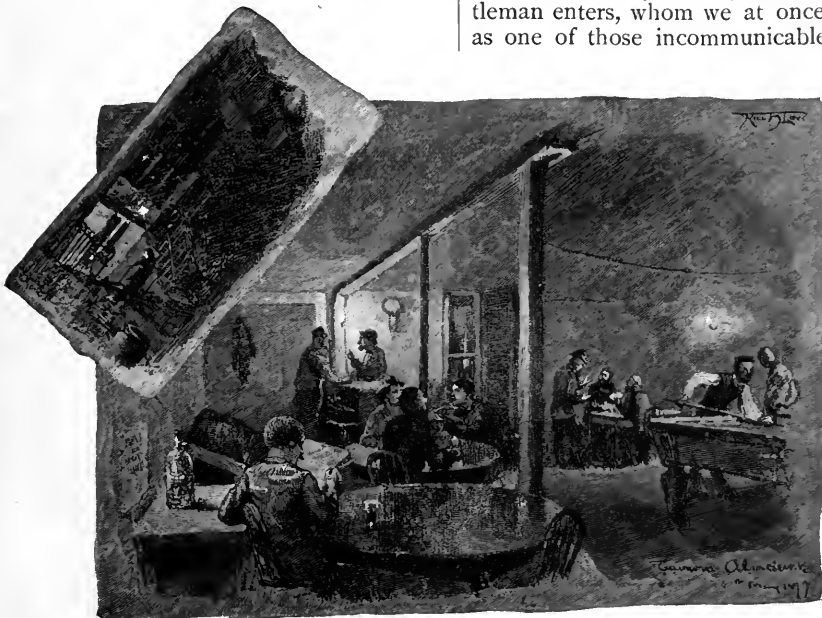

TAVERNE ALSACIENNE, INSIDE AND OUT.

ances that become familiar to us in the passing throngs of a great city—we see them day after day and year after year, until every peculiarity of their features is fitting as exactly as an epidermis; a silk hat with an obsolete flat brim, and a pair of prunellos; conspicuously pinned to the lapel of his coat were the ribbon and silver



MAKING ARTIFICIAL LEAVES.

impressed upon our memory; we see them growing older and grayer, with the fluctuations of fortune manifest in the shabbiness or fashionableness of their attire; but we never *know* them, and always pass with a greeting that is mute. This little gentleman who enters the "Restaurant du Grand Vatel,"—how many years is it since we first saw him? Long as the time is, we do not detect the least change in him. What he was, strolling out of the *quartier* into the leafy quiet of Washington Square one morning in spring six years ago, he is still. There is a degree of imperishability about him. We were struck then by the elasticity of his diminutive but graceful figure, his military bearing, and the superlative neatness of his dress. He wore a suit of dark blue cloth, the double-breasted frock coat

cross of some foreign order; the cloth was thread-bare, the hat no longer glossy, and the boots were by no means water-proof; he walked erect and with a measured tread and his black mustache was fastidiously curled. In every particular he is unaltered to-day; his clothing shows precisely the same degree of wear; his step is as buoyant, his face as fresh, and his mustache as black as ever. If his life had been suspended immediately after our first meeting, and his garments packed in camphor, secure from moth and sunshine, neither animation nor garments being resumed until now, the restoration could not have shown completer immutability. The genteel poverty of his dress and the dignity of his manners are combined with a placid reserve and an automatic precision of movement. "He is

probably an old soldier and adherent of the Empire," said my friend, "and above a soldier a beau: punctilious in points of honor and Quixotically exalted in ideas. Truly, this is a pitiable exile for him. I can see a yearning for Paris and his old-time haunts in his eyes, but mixed with the bitterness of his fate is a sweet resignation."

The door opened, and a half-intoxicated, bleary-eyed fellow entered with a great noise. Leroy tried to put him out, but he became effusively affectionate. "A good fellow," said the proprietor to us, "but he received a fortune from France a month ago and has been drunk ever since." Extremes meet at the "Restaurant du Grand Vatel." The poor professor and the gentlemanly old soldier set their "glorias" on the same benches with sottish artisans to whom labor is a *dernier ressort*.

At the "Taverne Alsacienne" in Greene street, a lower and more vicious class is to be seen. We enter a gloomy basement with an impoverished bar at one side and a much-worn billiard table at the end. It matters not what the hour is, whether it be in the forenoon, afternoon, or past midnight. A circle of men is gathered around the tables absorbed in piquet, *écarté* or *vingt-et-un*. Most of them are without coats, and the shabbiness of their other garments is lit up by a brilliant red bandanna kerchief or a crimson overshirt. Keen glances are shot at us; for the tavern has a certain *clientèle* outside of which it has few customers, and suspicion is rife at our invasion. A stranger in the "Taverne Alsacienne" is very likely to be a spy or a detective, and the *habitués* are sensitive under inspection. They are drinking wine, vermouth, and greenish-opaline draughts of absinthe. Staggering in unnerved and stupefied from the previous night's debauch, they show few signs of vitality until four or five glasses of the absinthe have been drunk, and then they awaken; their eyes brighten and their tongues are loosened—the routine of play, smoke and alcohol is resumed.

Besides the ordinary trades—the butcher's, the baker's, the grocer's, and the carpenter's—which are supported by all communities, and which in the French quarter have national representatives, the industries of the colony are limited, with a few exceptions, to artificial flower-making, leaf-making and feather-dyeing. In the attics of the tenement houses entire families are found engaged in one of these occupations. The materials are supplied by the large manu-

facturing firms, and out of muslin and wire roses, lilies and daisies grow in cheap profusion for the unfashionable trade. Sometimes one woman hires a number of children, paying each fifty cents a week, and the little hands are employed on the simplest details. Again, Mademoiselle Julie and her sister, Marie, work all alone in their "sky-parlor," and manage to live comfortably and decently on very small earnings, indeed. Embroidery is also largely engaged in, giving employment to both men and women; and sweetmeats are manufactured which rival in appearance the most appetizing imported *bon-bons*. One little shop is kept by an ingenious person, who devotes himself to repairing damaged *bric-à-brac* and art treasures; he promises to renew pictures blistered by fire, to put together a broken statuette so that not a trace of the operation can be seen, or to restore a precious *meerschaum* suffering from an aggravated fracture. All the occupations of the quarter are "light," requiring taste and adroitness rather than physical strength. Among others in the colony are large numbers of skilled artisans, who are brought from France for a term of years by such firms as Tiffany's, and who are handsomely paid.

It is not easy to form an exact estimate of the whole number of French in the city. We had been informed that it was about twenty thousand, and we visited the shabby little consular office in Bowling Green to verify the statement. But the consular agents did not know; the archives of a consular office are usually indeterminate or unavailable. M. Munier, editor of the "*Courier des États Unis*," fixed upon twenty-four thousand as the probable number, curiously divided by him as follows: about eight thousand permanent residents of the city, who have made it their final home; about eight thousand who, like the imported workmen of Tiffany's, have come here to stay a period of from five to ten years, and eight thousand who are here "prospecting," and do not usually remain more than two or three years. The names of eight thousand are in the city directory. At least one-half of the whole number do not speak English fluently, or at all among themselves, and about one-third are ignorant of the language. Neither the proprietor of the "Restaurant du Grand Vatel," nor he of the "Taverne Alsacienne," nor the polite old dame who sells *sabots*, can talk except in their native tongue. But a school for teaching English to French adults

has been opened by the Board of Education, the female department in Marion street, and the male department in West Thirteenth street; these are well filled. There are four

homes, and giving money to others or finding employment for them. Two daily newspapers are published in the French language, the largest of which is the "Courier," a

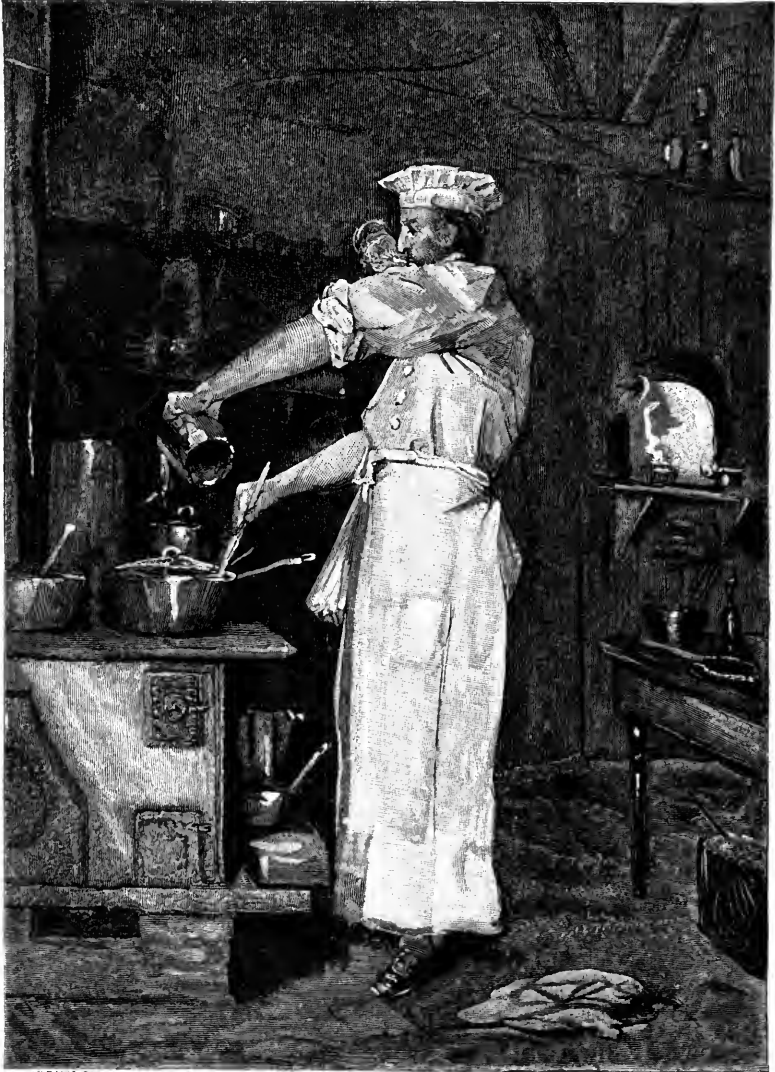

J.P. DAVIS-SC.

THE COOK OF THE GRAND VATEL.

French churches in the city,—one Roman Catholic and three Protestant,—and at least twenty French benevolent societies, one of which, the "Société Culinaire Philanthropique," is very wealthy. The "Société de Bienfaisance" fills a position of varied usefulness in helping the sick and penniless, sending the old and infirm to their former

member of the Associated Press. Many years ago, the late James Gordon Bennett described its proprietors as "the three starving Frenchmen," but its circulation has so increased that it is now a very valuable property.

There are gaps in the quarter which are filled by Americans, Germans and Italians.

Even the berated Asiatic has opened his laundry next door to that of Madame Lange—he copper-colored, reticent, assiduous; she florid, voluble and coquettish. The lowest element in the quarter is American; and the invasion is continuous, taking

away the national distinctiveness. By and by there will be no French Quarter, and we shall seek in vain for a blue blouse, the “Maison au Carreau Cassé,” the “Rendez-vous des Zouaves,” or the “Restaurant du Grand Vatel.”

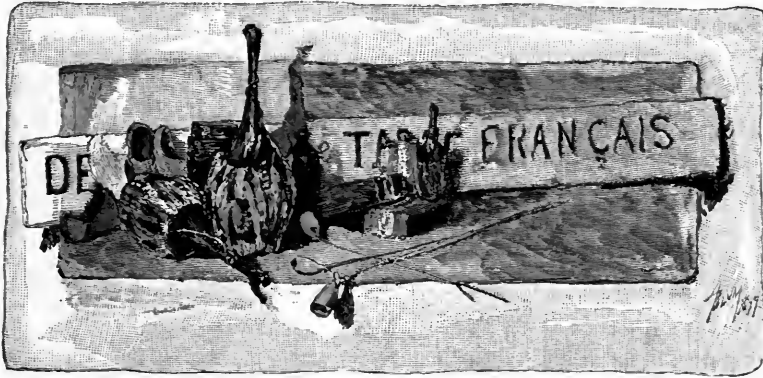

SUCCESS WITH SMALL FRUITS. I.

STRAWBERRIES FOR HOME AND MARKET.

TO PEOPLE who live in the country, small fruits are like heaven, objects of universal desire and very general neglect. As the warm weather approaches people tire of meats, and many not professed vegetarians long for some substitute for the heavy winter diet. Yet from how many country breakfast tables continues to rise the pungent odor of that meat into which the devils went, and out of which there is no proof

they ever came; when, with but little care and expense, the most tempting and nourishing fruits might be gathered from the garden under the window. The cabbage patch is there, and a few early vegetables perhaps, but the strawberry bed, even if it exists, is too often hidden by weeds, while the later small fruits struggle for bare life in some neglected corner.

The increased cultivation of small fruits



would make farm life more attractive. One of the sad features of our time is the tendency of young people to leave their country homes. Too often one does not need to look far for the reason. Life at the farm-house sinks into deep ruts, and becomes weary plodding. There are too many "one ideaed" farmers and farms. It is corn, potatoes, wheat, butter or milk. The staple production absorbs all thought, and everything else is neglected. Nature demands that young people should have variety, and this she furnishes in abundance. The stolid farmer too often ignores nature and the cravings of youth, and insists on

the stomach have been found nearer together by the metaphysicians than by the physiologists, and if the "house mother," as the Germans say, beamed often at her children over a great dish of berries, flanked by a pitcher of unskimmed milk, not only good blood and good feeling would be developed, but something that the poets call "early ties."

ORIGIN AND CHARACTERISTICS OF THE STRAWBERRY.

If there were as much doubt about a crop of strawberries, as concerning the origin of the name, the outlook would be dismal



THE HOME SHE MIGHT HAVE HAD.

the heavy monotonous work of his specialty, early and late, the year round, and then wonders why, in his declining years, there are no strong young hands to lighten his toil. The boy who might have lived a sturdy, healthful, independent life among his native hills, is a bleached and sallow youth, measuring ribbons and calico behind a city counter. The girl who might have been the mistress of a tree-shadowed country home, disappears under much darker shadows in town. Had not their early home-life been so meager and devoid of interest they might have breathed pure air all their days. Not the least among the means of making a home attractive, would be a well maintained fruit garden. The heart and

indeed. In old Saxon the word was *Strewberige* or *Streowberrie*, so named, says one authority, "from the straw-like stems of the plant, or from the berries lying strewn upon the ground;" another authority tells us "it is an old English practice" (let us hope a modern one also) "to lay straw between the rows to preserve the fruit from rotting on the wet ground, from which the name has been supposed to be derived; although more probably it is from the wandering habit of the plant, *straw* being a corruption of the Anglo-Saxon *strae*, from which we have the English verb *stray*." Again, tradition asserts that in the olden times children strung the berries on straws for sale, and hence the name. That the



SEEDS AND PULP OF THE STRAWBERRY.

strawberry should belong to the rose family, and that its botanical name should be *fragaria*, from the Latin *fragro* to smell sweetly, will seem very appropriate and familiar. Many intelligent people, however, need to be told that, strictly speaking, the small seeds scattered over the surface of the berry are the fruit, and it is to perfect these seeds that the plants blossom, the stamens scatter and the pistils receive the pollen on the convex receptacle, which, as the seeds ripen, greatly enlarges and becomes the pulpy mass that is popularly regarded as the fruit. So far from being the fruit, it is only "the much altered end of the stem," which sustains the fruit.

The innumerable varieties of strawberries that are now in existence appear, either in their character or origin, to belong to five great and quite distinct species. The first of these, and for a long time the only one of which we have any record, is the *Fragaria Vesca* or the Alpine strawberry. It is one of the most widely spread fruits of the world, for it grows, and for centuries has grown, wild throughout northern and central Europe and Asia; and on this continent, from time immemorial, the Indian children gathered it from the Northern Atlantic to the Pacific. In England this species exhibits some difference from the Alpine type, and was called by our ancestors the wood strawberry. The chief difference between the two is in the form of the fruit; the wood varieties being round and the Alpine conical. They are also subdivided into white and red, annual and monthly varieties, and those that produce no runners, which are now known as bush Alpines. The Alpine as we find it, growing wild, was the strawberry of the ancients. It is to it that the suggestive lines of Virgil refer,

"Ye boys that gather flowers and strawberries,
Lo! hid within the grass a serpent lies."

There is no proof, I believe, that the strawberry was cultivated during any of the ear-

lier civilizations. Some who wrote most explicitly concerning the fruit-culture of their time do not mention it, and Virgil, Ovid and Pliny name it but casually, and with no reference to its cultivation. It may appear a little strange that the luxurious Romans, who fed on nightingales' tongues and peacocks' brains, and scoured earth and air for delicacies, should have given but little attention to this fruit. Possibly they early learned



THE ALPINE STRAWBERRY (*FRAGARIA VESCA*).

the fact that this species is essentially a wildling, and, like the trailing arbutus, thrives best in its natural haunts. The best that grew could be gathered from mountain-slopes and crevices of the rocks. Its congener, the wood strawberry, was the burden of one of the London street cries 400 years ago, and to-day the same cry, in some language or other, echoes around the northern hemisphere as one of the inevitable and welcome sounds of early summer. The Alpine and wood strawberries tend to reproduce themselves with such unvarying exactness that cultivation makes but little difference.



HAUTBOIS OR HAARBEER STRAWBERRY (*FRAGARIA ELATIOR*).

In Europe, slight advance was made in strawberry culture until after the introduction of other species more capable of variation and improvement. Still, attempts were made from time to time. The Alpines dif-

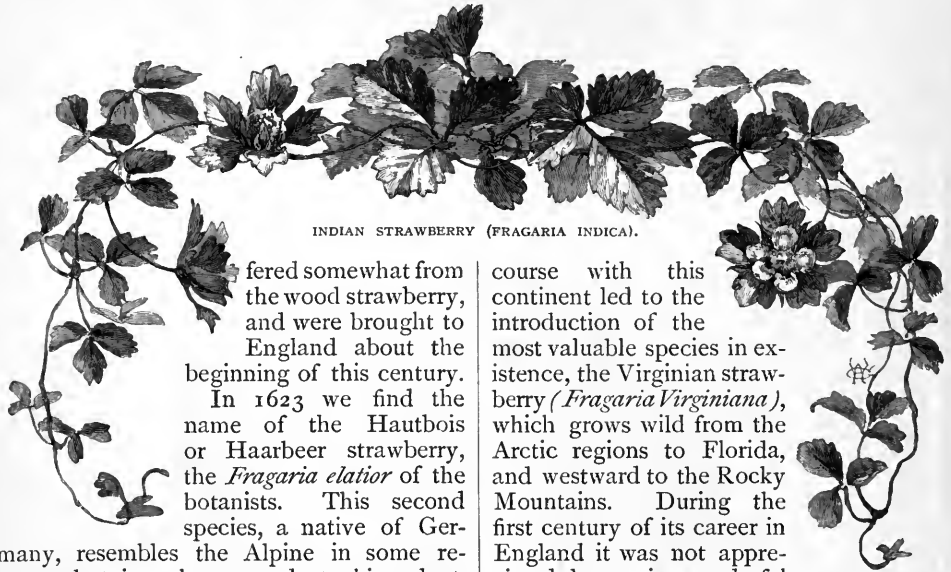
INDIAN STRAWBERRY (*FRAGARIA INDICA*).

ferred somewhat from the wood strawberry, and were brought to England about the beginning of this century.

In 1623 we find the name of the Hautbois or Haarbeer strawberry, the *Fragaria elatior* of the botanists. This second species, a native of Germany, resembles the Alpine in some respects, but is a larger and stockier plant. Its fruit has a peculiar musky flavor, which has never found much favor in this country. It is therefore a comparatively rare fruit in our gardens, nor do we find much said of it in the past.

There is scarcely any record of progress in strawberry culture, until after the introduction of the two great American species. It is true that in 1660 a fruit grower at Montreuil, France, is "said to have produced a new variety from the seed of the wood strawberry," which was called the "Capron" and afterward the "Fresant." It was named as a distinct variety one hundred years later, but I doubt whether it differed greatly from its parent. Be this as

COMMON WILD STRAWBERRY (*FRAGARIA VIRGINIANA*).

it may, it is said to be the first improved variety of which there is any record.

Early in the seventeenth century, inter-

course with this continent led to the introduction of the most valuable species in existence, the Virginian strawberry (*Fragaria Virginiana*), which grows wild from the Arctic regions to Florida, and westward to the Rocky Mountains. During the first century of its career in England it was not appreciated, but as its wonderful capacity for variation and improvement—in which it formed so marked a contrast to the wood strawberry—was discovered, it began to receive the attention it deserved. English gardeners learned the fact of which we are making so much to-day, that by simply



FRAGARIA CHILENSIS.

sowing its seeds, new and possibly better varieties could be produced. From that time the tendency has increased to originate, name and send out innumerable seedlings, the majority of which soon pass into oblivion, while others survive and become popular, and, as a rule, in proportion to their merit.

The *Fragaria Virginiana*, therefore, or common wild strawberry, which is found in all parts of North America, east of the Rocky Mountains, is the parent of nine-tenths of the varieties grown in our gardens; and its improved descendants furnish nearly all the strawberries of our markets. As we

have seen, the *Fragaria Vesca* or the Alpine species of Europe, is substantially the same to-day as it was a thousand years ago. But the capacity of the Virginian strawberry for change and improvement is shown by three great landmarks in the

last great species or subdivision that we now have to consider. Like the *F. Virginiana*, it is a native of the American continent, and yet we have learned to associate it almost wholly with Europe. It grows wild on the Pacific slope from Oregon to



THE NEW YORK FLOWER AND FRUIT MISSION.—A GIFT OF STRAWBERRIES.

American culture of this fruit—1, the production of "Hovey's Seedling," by C. M. Hovey of Cambridge, Massachusetts, forty-five years ago; 2, of the "Wilson's Albany Seedling," originated by John Wilson of Albany, New York, about twenty-five years ago; and, 3, in our own day, of the "Monarch of the West," given to the world by Jesse Brady, of Plano, Illinois.

There are but two more species of the strawberry genus. Of the first of these the *Fragaria Indica* or Indian strawberry, there is but little to say. It is a native of Northern India, and differs so much from the other species that it was formerly named as a distinct genus. It has yellow flowers and is a showy house-plant, especially for window baskets, but the fruit is dry and tasteless. It is said by Professor Gray to have escaped cultivation and become wild in some localities of this country.

Fragaria Chilensis, or *Grandiflora*, is the

Chili, creeping higher and higher up the mountain as its habitat approaches the equator. It is a large, robust species with very firm, thick leaflets, soft and silky on the under side. The flowers are larger than in the other species; the fruit in its native condition, also averages much larger, stands erect instead of hanging, ripens late, is rose colored, firm and sweet in flesh, and does not require so much heat to develop its saccharine constituents; but it lacks the peculiar sprightliness and aroma of the Virginia strawberry. It has, however, become the favorite stock of the European gardeners, and seems better adapted to transatlantic climate and soil than ours. As a species it requires the high and careful culture that they are able and willing to give it in Europe. The majority of imported varieties have failed in the United States, but a few have become justly popular in regions where they can be grown. The

"Triomphe de Gand" may be given as an example, and were I restricted to one variety, I would take this. The "Jocunda" also is one of the most superb berries in existence, and can be grown with great profit in many localities.

Thus the two great species which to-day are furnishing ninety-nine hundredths of the strawberries of commerce and of the garden both in this country and abroad, came from America, the *Fragaria Chilensis* reaching our eastern states by the way of Europe and in the form of the improved and cultivated varieties that have won a name abroad. We are now crossing the importations with our own native stock. President Wilder's superb seedling, which has received his name, is an example of this blending process: it is a child of the "La Constante" and "Hovey's Seedling," and thus unites the characteristics of the two great strawberry species of the world, the *F. Virginiana* and *F. Chilensis*.

It will be seen that the great law of race extends down even to strawberry plants. As in the most refined and cultivated peoples there is a strain of the old native stock which ever remains a source of weakness or strength and will surely show itself in certain emergencies, so the superb new varieties of strawberries, the latest products of horticultural skill, speedily show in the rough and tumble of ordinary culture whether they have derived their life from the hardy *F. Virginiana* or the tender and fastidious *F. Chilensis*. The "Monarch of the West" and the "Jocunda" are the patricians of the garden, and on the heavy portions of my land at Cornwall I can scarcely say to which I give the preference. But the "Monarch" is Anglo-Saxon and the "Jocunda" is of a Latin race, or to drop metaphor, the former comes of a species that can adapt itself to conditions extremely varied and even very unfavorable, and the latter cannot.

There are strawberries that will grow almost anywhere and under any circumstances, and there is another class that demands the best soil and culture, but from the soil of a good garden with a little pains one can obtain the finest fruit in existence. There is no occasion to plant only those kinds which are grown for market solely because they are productive and hard enough to endure carriage for a long distance. The only transportation to be considered is from the garden to the table, and therefore table qualities can be made our

chief concern. If the soil is light and sandy, one class of choice high flavored varieties can be raised; if heavy, another class. Many worry over a forlorn weedy bed of some inferior variety that scarcely gives a week's supply, when with no more trouble than is required to raise a crop of celery, large and delicious berries might be enjoyed daily at home for five weeks from twenty different kinds, and plenty be left for the table of a friend or for the equally gracious gifts one may make through such charitable societies as the "Flower and Fruit Mission," of New York. In the garden, especially if there can be irrigation, the best of the foreign blooded varieties can be grown with entire success.

The strawberry of commerce is a much more difficult problem. The present unsatisfactory condition of affairs was admirably expressed in the following editorial in the *Evening Post*, June 12th, 1876, from the pen of the late William Cullen Bryant:

"In general an improvement has been observed of late in the quality of fruit. We have more and finer varieties of the apple; the pear is much better in general than it was ten years since; of the grape there are many new and excellent varieties which the market knew nothing of a few years ago, and there are some excellent varieties of the raspberry lately introduced. But the strawberry has decidedly deteriorated, and the result is generally owing to the general culture of Wilson's Albany for the market. Wilson's Albany is a sour, crude berry, which is not fully ripe when it is perfectly red, and even when perfectly ripe is still too acid. When it first makes its appearance in the market it has an exceedingly harsh flavor and very little of the agreeable aroma which distinguishes the finer kinds of the berry. If not eaten very sparingly, it disagrees with the stomach, and you wake with a colic the next morning. Before Wilson's strawberry came into vogue there were many other kinds which were sweeter and of a more agreeable flavor. But the Wilson is a hardy berry, which bears transportation well; it is exceedingly prolific and altogether hardy—qualities which give it great favor with the cultivator, but for which the consumer suffers. The proper way of dealing in strawberries is to fix the prices according to the quality of the sort. This is the way they do in the markets of Paris. A poor sort, although the berry may be large, is sold cheap; the more delicate kinds—the sweet, juicy and high-flavored—are disposed of at a higher price. Here the Wilson should be sold the cheapest of all, while such as the Jocunda and the President Wilder should bear a price according to their excellence. We hope for our part that the Wilsons will, as soon as their place can be supplied by a better berry, be banished from the market. It can surely be no difficult thing to obtain a sort by crossing which shall bear transportation equally well, and shall not deceive the purchaser with the appearance of ripeness."

In spite of all that is annually said and

written against the "Wilson" it still maintains its supremacy as *the* market berry. Those who live near the city, and to some extent can make special arrangements with enlightened customers, find other varieties more profitable, even though the yield from them is less and some are lost from lack of keeping qualities. Those who send from a distance, however, and must take their chances in the general market, persist in raising this "sour, crude berry," which is red before it is ripe, and hard enough to stand the rough usage which it is certain to receive from the hands through which it passes. I do not expect to see the day when "Wilson's," or some berry like it, is not the staple supply of the market, although I hope and think it will be improved upon. But let it be understood they are "Wilson's"—the cheap *vin ordinaire* of strawberries. If genuine strawberries are wanted the purchaser must demand them, pay for them and refuse "sour, crude" berries. The remedy is solely in the hands of the consumers. If people would pay no more for Seckel than for Choke pears the latter would be the only ones in market, for they can be furnished with the least cost and trouble. It is the lack of discrimination that leaves our markets so bare of fine flavored fruit. What the grower and the grocer are seeking is a hard berry which if not sold speedily will "keep over." Let citizens clearly recognize the truth,—that there are superb, delicious berries, like the "Triomphe," the "Monarch," the "Charles Downing," and many others, and insist on being supplied with them, just as they insist on good butter and good meats, and the problem is solved. The demand will create the supply; the fruit merchant will write to his country correspondents: "You must send fine flavored berries. My trade will not take any others, and I can return you more money for half the quantity of fruit, if it is good." The most stolid of growers would soon take such a hint. Moreover, let the patrons of high-priced hotels and restaurants indignantly order away "sour, crude berries," as they would any other inferior viand, and caterers would then cease to palm off "Wilson's" for first-class strawberries. If these suggestions were carried out generally, the character of the New York strawberry market would speedily be changed. It is my impression that within a few years only those who are able to raise large, fine fruit will secure profitable returns. Moreover, we are in a transition state in respect to varieties, and there

are scores of new kinds just coming before the public for which wonderful things are claimed. I shall test nearly a hundred varieties myself the coming season; but I am satisfied in advance that nine-tenths of them will be discarded within a few years. Indeed, I doubt whether the ideal strawberry, that shall concentrate every excellence within its one juicy sphere, ever will be discovered or originated. We shall always have to make a choice, as we do in friends, for their several good qualities and their power to please our own peculiar tastes.

There is, however, one perfect strawberry in existence,—the strawberry of memory,—the little wildlings that we gathered, perhaps, with those over whom the wild strawberry is now growing. We will admit no fault in it, and, although we may no longer seek for this favorite fruit of our childhood, with the finest specimens of the garden before us, we sigh for those berries that grew on some far-off hill-side, in years still farther away.

CHOICE OF SOIL AND LOCATION.

THE choice that Tobias Hobson imposed on his patrons when he compelled them to take "the horse nearest the stable door" or none at all, is one that often must be made in selecting strawberry ground. We must use such as we have or raise no berries. It has been said that "with no other fruit do soil and locality make so great a difference;" and I am inclined to think that while this is truer of the raspberry, it is also thoroughly established that location and native qualities of soil are among the first and chief considerations in working out the problem of success with strawberries.

It is a generally admitted fact that the very best soil and the one adapted to the largest number of varieties is a deep sandy loam, moist, but not wet in its natural state. All the varieties with which I am acquainted will do well on such land if it is properly deepened and enriched. Shall the fact that we have no such soil and cannot obtain it discourage us? Not at all. There are choice varieties of strawberries that will grow in the extremes of sand or clay. More effort will be required, but skill and information can still secure success; and advantages of location, climate, and nearness to good markets may more than counterbalance natural deficiencies in the land. Therefore, if one finds himself in an unfavorable climate, and shut up to the choice of land the reverse of

a deep, moist, sandy loam, let him pit his brain and muscle against all obstacles.

Let it be well understood that strawberries cannot be made to do well on ground exhausted by the roots and covered by the shade of trees. On many farms, and even in some gardens, there are several varieties of soil and location, and by placing early kinds on warm, sunny slopes, and giving late varieties moist, heavy land and cool northern exposures, the season of this fruit can be greatly prolonged. The advantage of this long-continued supply for the family is obvious, but it is often even more important to those whose income is dependent on this industry. It quite often occurs that the market is "glutted" with berries for a brief time in the height of the season. If one's crop matures in the main at such a time, the one chance of the year passes, leaving but a small margin of profit, whereas, if the grower prolongs his season

by a careful selection of soils as well as of varieties, he may sell a large portion of his fruit when it is scarce and high.

Climate, also, is a very important consideration. In the far north, sheltered situations and light warm land should be chosen for the main crop, but in our latitude and southward, it should always be our aim to avoid that hardness and dryness of soil that cut short the crops and hopes of so many cultivators.

It is also of vital importance that the fruit farm should be near good shipping facilities, and that there be sufficient population in the immediate vicinity to furnish pickers in abundance. It will be far better to pay a much higher price for land—even inferior land—near a village and a railroad depot than to attempt to grow these perishable fruits in remoter regions. A water communication with the market is, of course, preferable to any other.



THE STRAWBERRY OF MEMORY.



THE MICHIGAN GRAYLING.

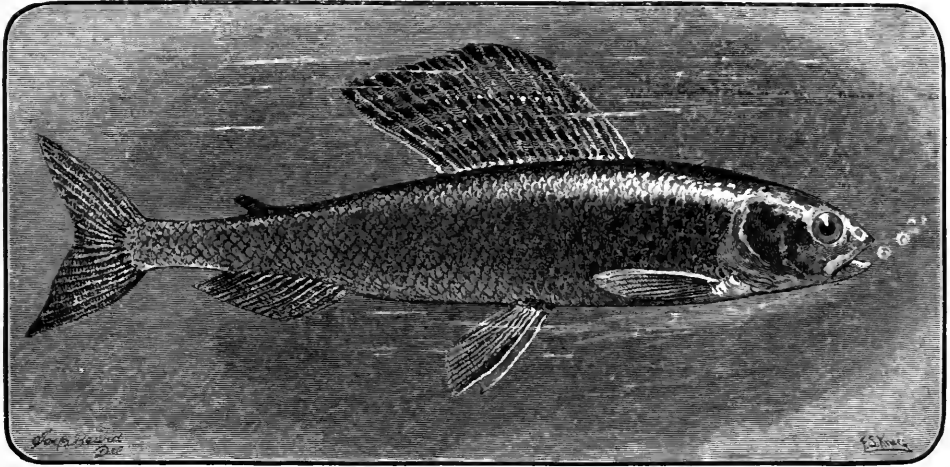

THE MICHIGAN GRAYLING (THYMALLUS TRICOLOR).

UNTIL within a few years that portion of Michigan extending from the forty-fourth parallel to the Straits of Mackinaw, dotted with beautiful lakes and traversed by many a clear winding river was *terra incognita* to the fly-fisher; and although we were told years ago by explorers and adventurous anglers that trout in great numbers and of large size were taken in the waters of the northern portion of the peninsula, the grayling by its true name was unknown, and does not now form a subject for any of our angling authors. It was supposed that, except in the Arctic regions, it did not exist on our continent. About ten years ago, however, hunters and those who were looking up timber lands began to talk of a white-meated fish with all the game qualities of the trout, which they captured in streams of both water-sheds—east and west—as an addition to their venison and “hard tack.” It was known to them as the “white trout,” the “Crawford County trout,” and under other local names until a specimen in alcohol was sent to Professor E. D. Cope, of the Philadelphia Academy of Natural Sciences, who described it in the proceedings of that institution in the year 1865, and gave it the scientific name of *Thymallus tricolor*, the generic name arising from the fresh thyme-y smell of the fish when first taken from the water, the specific appellation having reference to its beautiful dorsal fin. And yet its discovery as a true grayling escaped the notice of nearly all of our fly-fishers;

VOL. XIX.—2.

and to the few who might have meditated an expedition in search of it, its habitat was far off and then almost inaccessible. The following passage, however, from “American Fish Culture” (p. 196), by the present writer and published by Porter & Coates, in 1867, soon after Professor Cope described the fish, attracted the notice of Mr. J. V. Le Moyne, of Chicago.

“While on a trout-fishing excursion lately in the northern part of Pennsylvania, I met a very intelligent, though not a scientific person, who informed me that in exploring some timber lands on the Au Sable, in Michigan, he came across a new kind of trout which he had never seen before. From his description it was doubtless this new species of *Thymallus*. He said it readily took a bait of a piece of one of its fellows, a piece of meat being used to capture the first fish; and that it was very beautiful and of delicious flavor.”

The following summer, after consulting persons interested in timber lands, Mr. Le Moyne packed his “kit” and found his way by steamer to Little Traverse Bay, and thence by canoe through a series of lakes to the River Jordan, where he had great sport, not only with grayling, but with trout of good size, taking both from the same pool, and not unfrequently one of each on the same cast. I may here mention that the Jordan is one of the few streams of Michigan in which both are found. Trout are unknown in the Manistee and Au Sable.

My friend, Mr. D. H. Fitzhugh, jr., of Bay City, the year following took them in the Rifle and went by a new railroad then being built to the Hersey and Muskegon, walking twenty miles of the distance. He had been waiting with much interest the extension of the Jackson, Lansing and Saginaw Railroad northward, and in 1873, when it crossed the Au Sable, he launched his boat high up on that lovely river. Since then the fame of the rare sporting qualities of this fish has spread among anglers, and they now come from many of our large towns and cities (especially those of the West) to camp on the banks of the Michigan rivers and enjoy the sport.

The European species (*T. vexillifer*) is mentioned by all English authors on angling from the time of Dame Juliana Berners to the present. The opinion is advanced by some of them that it was introduced into England when under the religious sway of the see of Rome, as it is generally found in rivers near the ruins of old monasteries. Sir Humphrey Davy, in his "Salmonia" (1828), wrote of it as inhabiting the Avon, the Ure, the Nye and the Dee; and Hofland (1839) in addition to those mentions the Trent, the Dove, the Derwent, the Wharfe, and a few other rivers. Sir Humphrey Davy also tells us that it is found in some of the streams of the Alpine valleys, and he intimates in some of the rivers of Sweden and Norway. A friend of the writer, who of late years has been in the habit of spending his summers in Bavaria, has had fair sport with grayling in the Isar and Traun, near Munich and Traunstein, as also in the Inn and Salza, and mentions the names of a few quiet English anglers who come annually in September to fish these rivers.

European waters, however, were probably never as prolific of grayling as those of Michigan; for trout, which feed largely on the young of all fish, are there found in the same streams. In Michigan rivers, where grayling most abound there are no trout, and the fry of their own and other species are never found in their stomachs. The various orders of flies which lay their eggs in running water and the larvæ of such flies appear to be their only food.

Writers in sporting papers have recently claimed that grayling have also been found in the older states of the Union. If this be the fact, they are now extinct. They are said to exist in some few of the rivers of Wisconsin, which is quite probable, and

also in Montana and Dakota. Dr. Richardson, in his "Fauna Boreali-Americana," gives not only a glowing description of the exquisite beauty of Back's grayling (*T. signifer*), but speaks with all the ardor of a true angler of its game qualities. The Esquimaux title, *Hewlook powak*, denoting wing-like fin, he says, alludes to its magnificent dorsal, which, as in the Michigan grayling, exceeds in size and beauty that of the European species.

Grayling, wherever found, are spring spawners, as also are the smelt and the capelin or spearing. All other genera of the salmon family spawn in autumn. The usual time with grayling, both here and in Europe, is the latter part of April and early in May. They do not push for the very sources of rivers, leaping falls and flapping sideways over shallows to find some little rivulet as trout do, but deposit their ova in the parts of the stream where they are taken, or if such portions are not of the proper temperature, they will sometimes seek the mouths of smaller and cooler affluents. The time of their spawning is limited to a few days, or a week or so. Of the experts who have gone to the Au Sable to express the ova, fertilize it, and bring it East to introduce this fish into the Atlantic states, one found that they were not ready to spawn, and the next season, another, who went a week or so later, found that they had spawned. I have taken fry as long as my little finger on the first of September, which were the produce of eggs spawned in April. Those that came from ova of the preceding year were six inches long; at two years old, they are ten or twelve inches long; at three years old, they are thirteen to fifteen inches long, and at four years, sixteen or seventeen inches, and weigh from three-quarters of a pound to a pound and a quarter; each succeeding year adding proportionately less to their length and more to their girth. An abundance or deficiency of food, however, has much influence on their growth, while some are naturally more thrifty than others. Sir Humphrey Davy says: "Grayling hatched in June become in the same year, in September or October, nine or ten inches long, and weigh from half a pound to ten ounces, and the next year are from twelve to fifteen inches." On this point, as will be seen from the foregoing, I differ with him. I think he must have written from hearsay.

In Michigan, in a day's fishing, the true-hearted angler returns to the water a great

many more than he puts in his live-box. He will keep none under a half pound, and where the streams are so abundantly stocked, he will not begrudge their liberty to all under that weight. Our grayling are much more slender than the European species, but, if we credit English authors, do not attain as large a size. Three-fourths of a pound with us is a good average size, and one of a pound and a quarter is considered a large fish. I have *heard*, however, of their being taken in the Jordan over three pounds. The grayling is a fish of more symmetrical proportions than the trout, although it has not the vermilion spots and bright colors over its body, but its head and mouth are much smaller, and with handsome, prominent eyes. Its habits also differ materially from those of the trout. It is never found in the strong turbulent water at the head of a rift, but in the deeper portions of the smoothly gliding stream. It avoids a bottom of clay or the mosses so common to the beds of Michigan rivers, but is always found on gravel or sand. Its rise is straight up—sharp and sudden, and when its attention is once drawn to the artificial line, it does not turn back as a trout does, on getting a sight of the angler, but in its eagerness disregards him entirely, and in running a river with the speed of the current, or even if the boat is poled along down stream, it frequently takes the fly within a few feet of the pole or the boat. Its play is quite as vigorous as that of the trout, and it leaps frequently above the surface of the water before it is sufficiently exhausted to be drawn in. There is this difference, however, between the two. The trout, like a certain denomination of Christians, seems to believe in “final perseverance,” and will kick and struggle to the last, even as it is lifted in, while the grayling, after you have sufficiently overcome its obstinate pluck to get its head above water, is taken in with pendent tail, as much as to say, “It’s all up;” but as soon as it touches the floor of the boat, its flapping and floundering begin. If it takes a sheer across the current, with its large dorsal fin, it offers greater resistance than the trout. Where they are so numerous, one seldom uses the landing net, for few escape by breaking away, and if they do there are more to take hold at the next cast.

If in fishing with a whip of three flies the angler hooks a fish on either of his droppers, the stretcher fly as it sails around beneath is pretty sure of enticing another, and not

unfrequently the disengaged dropper hooks a third fish. Sometimes, as I have sat on the cover of the live-box, I have looked down to see three of these bright fish, after I had exhausted them, all in a row, their dorsal fins erect and waving in the clear water like so many beautiful leaves of the coleus. Nor is the grayling in taking the fly as chary a fish as the trout. On a perfectly still water you may see the latter rising and taking in the minute natural flies, when the veriest artificial midge will not tempt it; but let even a light breeze spring up and a ripple appear on the surface, and then it cannot distinguish the natural from the artificial, and will take hold. The grayling, on the contrary, is the most eager, unsophisticated fish imaginable. When it sees anything bearing the most remote semblance of life, it “goes for it,” even if the water is as smooth as a mirror.

The whole of Michigan, south of the Straits of Mackinaw, may certainly be called flat country. The only rising grounds to be found are a few sandy eminences—they can scarcely be called hills—the formation of which we leave the geologist to account for. And yet the rivers abrading against these sand-hills occasionally cause precipitous bluffs (few of which exceed a hundred feet) or such an elevation as is known in a lumberman’s parlance as a “roll-way.”

There is a gradual but almost imperceptible elevation from Bay City or Grand Rapids to the region where grayling are found. From the former to Grayling, where the railroad crosses the Au Sable, a distance of nearly a hundred miles, there is a rise of seven hundred feet, which gives the rivers an average current of about two and a half miles an hour. Wherever there is a contraction in the width of the stream, however, especially around a bend, its velocity may be three, four, or even five miles, but on account of the absence of rocks in the bottom, it almost invariably flows smoothly. The strength of the current can only be seen where the ends of half-sunken logs or “sweepers” project above the surface, or when the canoeman turns his prow up stream.

The grayling region, on the Lake Huron water-shed, has a top stratum of coarse white sand. On the streams flowing toward Lake Michigan, the sand is yellow, with more or less admixture of vegetable loam. The rains falling on these sandy plains and percolating through, meet with a lower stratum of impervious clay, and thus

form underground courses which crop out at the margin or in the beds of the streams, and keep them at the temperature of spring water.

The eighth longitudinal line west from Washington may be considered the apex of the water-sheds, declining East and West; although the head-waters of streams occasionally interlock. By a short "carry" one can pass from the head-waters of the Manistee to those of the Au Sable. I have seen marks on both of these streams that gave evidence that surveyors did so forty years ago, and have no doubt that it was a route used by the Indians in crossing from Lake Michigan to Lake Huron.

The country, except on the barrens, furnishes a fine growth of white and yellow pine, as well as oak, beech, maple, and other hard woods. White cedars,—the arbor vitæ of the East,—invariably fringe the banks of rivers a few miles below their sources, which are generally in ponds or lakes. These trees appear to love spring water, and do not appear until the stream has acquired that temperature. Growing on the banks of the streams, the current washes away the loose soil from their roots, which causes them to incline over and at last to fall into the water; and these are called "sweepers." These rivers, from the constant influx of

spring water, never freeze, and owing to the slight water-shed and sandy top-soil are not subject to freshets, a spring rise of two feet being considered excessive. Nor are they discolored by high water, a brown tinge only being imparted. Such streams, here and in Europe, are the home of the grayling, for it loves water of a low, even temperature and a smooth, steady current.

The game-laws of Michigan recently enacted forbid the spearing and netting of grayling at all times, and do not admit of them being taken even with hook and line from January until June. These fish acquire condition soon after spawning, but are better in autumn, and in season nearly all winter. So after the first of September the sportsman can unite shooting with fishing. Several summers ago in August, while running the Au Sable we counted twelve deer and two bears. As they were out of season and my friend Fitzhugh was a stickler for the observance of the game-laws in every instance, we resisted the temptation to shoot them.

The country I have described has, of course, none of that awe-inspiring scenery we find on the shores of Lake Superior, but with its clear, ever-flowing, ever-winding rivers over white and yellow sands, with graceful cedars projecting at a sharp angle from the banks, and every bend of the stream opening a new view, it is novel and pleasing to one who has been shut up all winter in a crowded city. In running a grayling stream, the feeling is one of peace and quietude. There are no song-birds in those deep woods. One only hears the far-off falling of some old forest tree, or that weird sound caused by the rubbing of the branch of one tree against that of another, as they are swayed to and fro by the wind, and in the distance one can almost fancy that it is a human voice. Otherwise all is as silent as death.

My first raid upon the grayling was in August, 1874, with Mr. Fitzhugh, of Bay City, on the Au Sable. We ran this river from Grayling, on the northern branch of the Jackson, Saginaw and Lansing Railroad to Thompson's, a distance



VIEW ON THE MANISTEE.

of a hundred and sixty miles. From Thompson's, after loading our two boats on a stout two-horse wagon and occupying another with springs, we drove twenty-five miles to Tawas City, and then after a few hours on a steamer back to Bay City. There is no

leave Bay City by railroad in the morning and arrive at Grayling early enough in the afternoon to embark and drop down stream seven or eight miles the same night. He should, however, engage boats and pushers beforehand.*

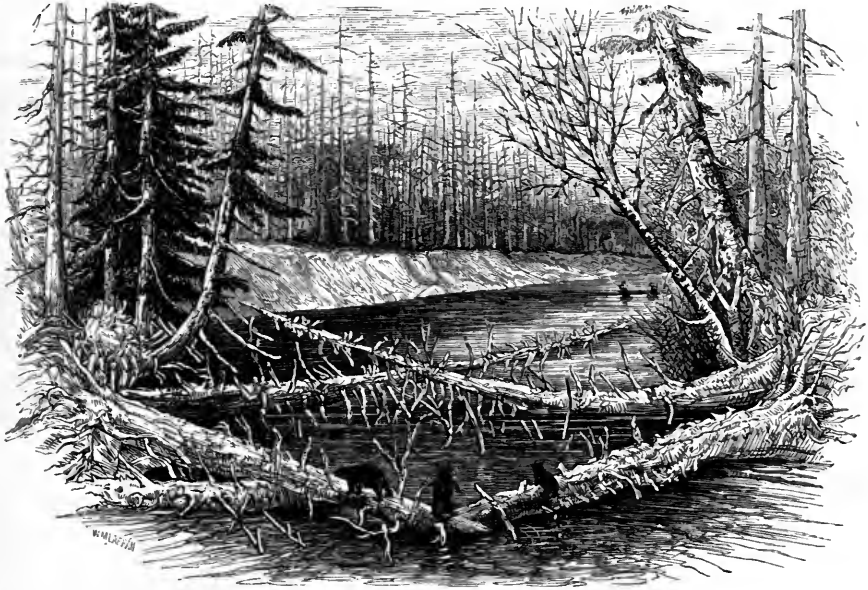

SWEEPERS IN THE AU SABLE.

grayling fishing at the station called Grayling, nor until one gets four or five miles down the stream where the cedars appear. From this as far as we ran it—and there was yet sixty miles of it below Thompson's—it is a beautiful stream, much prettier, I think, more rapid, and less obstructed with sweepers than the Manistee. The distance by land is about seventy miles. On our second day we killed and salted down—heads and tails off—a hundred and twenty pounds of fish, besides eating all we wanted. In one hanging rift close by the bank, as Len Iswel, my pusher, held on to the cedar boughs, I took at five casts fifteen fish, averaging three-quarters of a pound each. The following day we fished along leisurely until we had our live-boxes, containing each sixty pounds, so full that the fish began to die. Then we passed over splendid pools in which we could see large schools of grayling on the bottom without casting a fly; for we would not destroy them in mere wantonness. In a few days, however, we came across occasional timber camps, when we commenced fishing again, and supplied all hands with fresh fish. One can

There are two large branches, flowing almost as much as the main stream, that enter the Au Sable. The south-west comes in about forty-five miles below Grayling, and the north branch sixty miles below. On this last stream there is a sluice dam, and when it is let off to float logs during the summer and autumn, the water is discolored somewhat, and the fish do not rise as well. One can get all the fishing he wants by running as far down as the south-west branch, which as already stated, is forty-five miles by water, and is only twelve miles back to Grayling by land. He can engage a wagon at Grayling to come with ice on a stated day and haul back his boats, his luggage, and his fish, thus saving the labor of pushing back up stream, which would occupy two days of incessant toil.

When I fished the Manistee the latter part of August, 1875, I went from Grayling with Mr. Fitzhugh and another friend, accompanied by our pushers, over "the

* I would here say that sportsmen wishing to secure good men for fishing or hunting can do so by addressing L. P. Ramsdell or I. F. Babbit at Grayling, Crawford County, Michigan.

barrens," a distance of eight miles, to a camp established by I. F. Babbit, to fish with hook and line for the Bay City and Detroit markets. We made a permanent camp four miles below Babbit's and fished five days, giving him three-fourths of our fish, which he came for every day, and which (keeping none under a half pound) amounted to over five hundred pounds.

One of my most pleasant trips, however, was that of the latter part of August, and early in September, 1876, when in company with two young friends, I spent two weeks on the Manistee. We went by the Grand Rapids and Indiana Railroad to Mancelona, well up toward the Straits of Mackinaw. Here we loaded boats, stores, and camp equipage on a wagon drawn by a pair of stout horses, and journeyed eleven miles east to the head-waters of the main branch. Our trip was dashed with a spice of adventure and a good deal of hard work. We had struck the stream higher up than we expected. It was small, scarcely sufficient to float our boats, and still had the temperature it had acquired in the little lake which was its source. There were no cedars, which

which have been undermined by the current and have fallen in the water, and always across the stream. We had three days and a half of hard chopping, and hauling our boats over huge cedar logs, some of which had probably lain there for a century—for a cedar log if it remains in the water, never rots. On coming to some of these logs we had to make a "carry," placing our luggage on their mossy covered trunks and pulling our empty boats over. We would then load up and go on to cut more sweepers and make more carries. At last the stream widened and was free of sweepers, and we had magnificent fishing. The grayling were perfectly reckless, and would take one's flies within ten feet of the boats. It was virgin water; no fly had heretofore been cast on it. After a day's sport we came to the sweepers again, and had a day and a half more with them and half-sunken logs and a few carries. At two or three of these carries, the logs were over two feet through. Mosses had grown and spread on them until, as we saw by certain signs, bears used them as a highway. On one we found thrifty cedars growing at regular intervals from the parent trunk that



ON THE MANISTEE: CLEAR OF THE SWEEPERS AND INTO GOOD FISHING.

only appear when the streams have flown far enough from the ponds to feel the influence of spring water. On the morning of the second day we came to the cedars and cold water; and with them the sweepers, which are cedars, as already described,

were more than half a century old. Soon the stream increased so much in volume and was so wide that a tree falling across could not obstruct the passage of our boats; and finally we came to open water again. And so we ran the stream down to Walton

junction, a hundred and fifty miles by water, while it was scarce fifty on a beeline.

Notwithstanding the difficulties we encountered on this last trip, those who follow us over the same route will find it quite easy on account of the passage we opened, and in a day will make as much way down stream from the small bridge at its head as we made in four. On looking back I hardly begrudge the hard work it cost us; for the subsequent running of a hundred and fifty miles of beautiful river was much more enjoyable than camping for nearly a week, as we did in the summer of 1875, lower down the river.

The boat used on my first trip is worth description. It was built of white pine; bottom, 1 inch thick; sides, $\frac{5}{8}$; 16 feet long; 2.10 wide on top, 2.4 at bottom, and with a sheer of three inches on each side. The bottom was nearly level for eight feet in the center, with a sheer of five inches to the bow and seven inches to stern. The live-box was six feet from bow, extending back two feet. The sides were nailed to the bottom. Its weight was eighty pounds, and it carried two men—the angler and the pusher—with 200 pounds of luggage. With two coats of paint it cost about fifteen dollars. The angler sits on the movable cover of the live-box, which is water-tight from other portions of the boat, and has holes bored in sides and bottom to admit of the circulation of the water to keep the fish alive, and as he captures his fish he slips them into holes on the right and left sides. An ax was always taken along to clear the river of fallen logs and sweepers.

My customary tackle on these excursions is a twelve-foot rod of about eight and a half ounces; leaders eight feet long, and flies on hooks ranging from No. 7 to No. 10

(O'Shaughnessy). I have found most of the flies used on Pennsylvania streams effective, and one can scarcely go amiss in his selection. One summer, I used for two weeks the same whip, viz.: "Professor" for the stretcher, "Silver Widow" for first, and "White-winged Coachman" for second-dropper. The first is tied with Guinea-fowl feather for wings, an amber or yellow dyed hackle for legs, a yellow floss body wound with gold tinsel, and three sprigs of scarlet ibis for tail. The second has black wings, black hackle, and black body wound with silver tinsel. The third has white wings, red hackle, undyed, and body of peacock hurl.

As to stores. Last summer we found that for five men, including pushers, the following were about the right quantities for a two weeks' supply: 50 lbs. flour, 1 bushel potatoes, 25 lbs. of breakfast bacon, 12 lbs. butter, $\frac{1}{2}$ peck of onions, with corn meal, tea, coffee, sugar, condensed milk, a jar of pickles, and a few cans of corn and tomatoes. Bread is a difficult thing to take or to keep in good condition. I would advise, therefore, the taking of a portable sheet-iron stove, which with a baker and all other appliances and conveniences, does not weigh over thirty-five pounds. With a box of yeast powder, hot rolls can be had at every meal.

The Grand Rapids and Indiana Railroad goes to considerable pains to accommodate anglers. Nearly every station above Reed City is in close vicinity to some lake stocked with bass, muskallonge and pickerel, or some river teeming with trout or grayling. At such stations, boats, wagons, horses and men can be found to accompany parties of anglers. This road has also cabin cars, with stove, bunks, etc., which it will switch off at any station.

 IN CONFIDENCE.

The sea heard; and the deep, sad sea
Throbb'd with one bitter secret more,
But set no murmuring rumor free
By wind or bird, to cave or shore.

The stars saw; but no trembling star
Of all the wide, bewildering train
Has ever whispered from afar
The story of this hopeless pain.

The night knew; but the tender night
Unveils no tears, betrays no sighs;
She wraps away from sound and sight
Despairing hearts and watching eyes.

What if the night, and stars, and sea
Should, but for once, their pledge forget,
And softly breathe, alone to thee:
"She loved thee then, she loves thee yet?"

MR. MORRIS MOORE AND HIS OLD MASTERS.



RAPHAEL'S "APOLLO AND MARSYAS," OWNED BY MR. MORRIS MOORE OF ROME.

MANY times during the last ten years, Americans interested in matters pertaining to culture must have had their curiosity stirred by allusions to the "Raphael" of Mr. Morris Moore. Information on all such subjects—theoretically interesting to the world at large, but found to be actually of interest to a circle sorrowfully small—

reaches the public, as a rule, in a halting and fragmentary shape; and thus, while, here and there, allusions have appeared in the newspapers to Mr. Morris Moore as the owner of one very beautiful picture by Raphael, the "Apollo and Marsyas," little has been said of his other Raphael, the "Portrait of Dante," or of his Michelangelo,

"The Virgin of the Lectern." But these three pictures are of equal authenticity; and such is their beauty, so great is the interest that intrinsically attaches to them, no wonder if their presence in one private chamber in Rome has of late years made that room able to dispute with illustrious galleries, private and public, the suffrages

this room our attention is not too much distracted; although it is still true that any one of the three pictures owned by Mr. Moore is more than enough food for delighted contemplation for a single day. But what a relief to the weary visitor to Roman galleries to come upon one tranquil room where there are only three pictures,

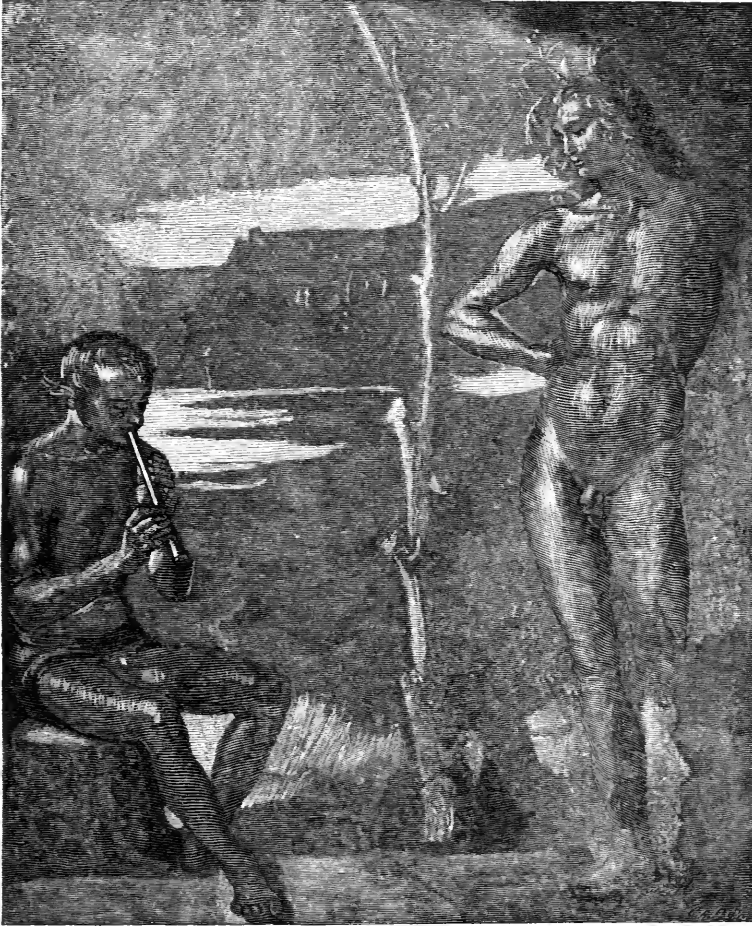

ORIGINAL SKETCH FOR THE "APOLLO AND MARSYAS," IN THE PRINT-ROOM OF THE ACCADEMIA DELLE BELLE ARTE, VENICE.

of the art-loving pilgrims to the Eternal City. One reason why this room of Mr. Moore's has been so much in vogue of late may perhaps be found in the pleasant company of Mr. Moore himself, who knows so well how to play the host, and to talk about his pictures, or not to talk about them, but to listen to his visitor, as the occasion may demand. Another reason may be found in the fact that one is not put to the troublesome labor of sifting, as in a gallery. In

even if every one of these is a masterpiece that must be studied.

The wish has been often expressed by Americans who have seen these pictures, that they might become the property of some one of the art institutions of our own country; and the editor of SCRIBNER, thinking he might strengthen the hands of these friends of a good cause, has taken pains to have two of Mr. Moore's pictures engraved for the magazine. The two chosen are

the "Apollo and Marsyas" by Raphael, and the "Virgin of the Lectern," by Michelangelo. The original drawing by Raphael for his picture, which has long been prized as one of the chief treasures of the Print Room of the Accademia delle Belle Arte in Venice, is also given. Before attempting to describe these pictures to our readers, it seems expedient to tell them something about Mr. Moore himself, to whose knowledge and perception we owe the discovery of these works, as we owe their preservation to his spirit of enthusiasm and self-sacrifice.

Mr. Moore is of English birth, and received his name of Morris (his full name is Morris John James Cole Moore) from a son of our Robert Morris, the well-known financier, who was visiting at his father's house when he was born and stood as godfather to the child. The elder Moore was, like many an Englishman at that time, a fervent admirer of America, which he dressed up in imagination to suit his own *a priori* theories; and his house was much frequented by Americans visiting London, who found there hospitality and a sympathetic society. No doubt it is to this early influence that Morris Moore owes his strong predilection for America and Americans. To have come from this side the water is a sure passport to his favor, and many an art-loving American has found in Mr. Moore's companionship a new pleasure in the life of Florence and Rome. He was taken in early youth to Italy, where his natural love of art was fostered and trained, "not with blinded eye-sight poring over miserable books," but by living studies, laboriously, enthusiastically pursued in the presence of the masterworks of the greatest artists. With small means, but knowing well how to use opportunity, Mr. Moore has visited every part of Italy, and has made himself familiar with her art in the only way in which familiarity can be acquired with any art, by a long-continued, minute study of the works themselves. It is only by such studies that a first-rate critic can be formed, but, it is almost superfluous to add, this practical education must be built up on a foundation of natural perception and an inborn love of the subject. It is in the very remarkable union of these essential elements that Mr. Moore's strength as an authority on Italian art consists. To make a man a critical authority, a knowledge of the literary side of the subject, no matter how extensive or minute, will not suffice; nor the having seen a great many works of art; nor even the possession

of good natural powers of perception. The first of these, indeed, a man may do without, but, while the others are essential, the wide experience must be analyzed and reduced to order by scientific observation, and judgment must restrain the eagerness of perception before a man can feel an honest confidence in his own power as a critic, or can, without misgiving, ask the world to trust him in that capacity.

With an eye fresh from the galleries of Italy, Mr. Moore, on his return to England, visited the National Gallery; and his indignation was roused by the condition in which he found the most valuable pictures of the collection,—pictures by Claude, Rubens, Paul Veronese, Valasquez,—on which "restorers," "cleaners," and "preservers" of all sorts were ruthlessly at work, with the permission if not with the active co-operation of the director, Sir Charles Eastlake. It was already too late with regard to some of the most important works to do more than protest, but the few works as yet untouched might be saved, and the utter ruin of some of those still in the hands of the "restorers" and "preservers" might be prevented by vigorous remonstrance. Mr. Moore at once sounded the alarm, and in a series of letters to the London "Times," under the signature of "Verax," made such a commotion that, as a first result, Director Eastlake, in 1847, resigned his position. It is difficult at the present day to understand how this gentleman ever came to be made director at all. It is probable that social influences had the shaping of the matter; certainly he was not appointed either because he was a good painter or because he was an authority in matters of art. He was one of the weakest painters of the namby-pamby school, his name as an artist hardly known even at home in his own time; while, for his knowledge of art, it is sufficient that he not only stood by and saw the finest pictures belonging to the nation and committed to his charge ruined, but also spent a large sum of the nation's money in most injudicious purchases, paying, for one item, £600 for a spurious Holbein, called, by himself, "The Portrait of a Medical Gentleman," which almost immediately afterward was withdrawn from the public view.

But Sir Charles Eastlake was protected by Prince Albert, to whom he owed his appointment, and he was upheld at this time not only by the Prince, but by the many German amateurs, dilettaanti, and so-called "professors," that surrounded the

court in those unhappy days for English art and English culture. He was soon appointed to the presidency of the Royal Academy, fitly succeeding Sir Martin Archer Shee, who only lives, like a fly in amber, in Charles Lamb's merry pun.* It was Shee who said before a Parliamentary Commission that he considered the Royal Academy a much more important establishment than the National Gallery, which he looked upon as a mere *hortus siccus*. He said, before the same body, that it would be difficult to find modern works so badly drawn as the cartoons of Raphael at Hampton Court. And, again, in trying to prevent the purchase by the nation of the so-called "Manchester" Madonna, then ascribed to Ghirlandajo, but now known to be by Michelangelo, he said he should be ashamed of any pupil of the Royal Academy who could not draw better than that. Sir Charles Eastlake, who succeeded in the presidency to this Bœotian *pur sang*, may be said to have handed in his credentials with this answer to a question of the committee: "I would *not* recommend the issuing of engravings from the drawings of the great masters, such as those of Michelangelo and Raphael in the collection at Oxford. I approve of the system of issuing outlines after the manner of Retzsch. Outlines after the manner of Retzsch would promote the higher class of art."

It happened that by an agreement entered into some years before between the two Institutions, the President of the Royal Academy is *ex officio* a trustee of the National Gallery. On his appointment to the presidency therefore, after the death of Shee, Sir Charles Eastlake, although he had resigned the directorship in 1847, became entitled, by virtue of his new position, to meddle again in the affairs of the National Gallery as a trustee. The "cleaning," "restoring," and "preserving" went on as before. But Mr. Morris Moore was not to be circumvented. He opened fire again, and this time, backed by men of eminence and position, the Earl of Onslow, Lord Elcho, Mr. Coningham, Walter Savage Landor, Mr. Seymour Kirkup and others, and most efficiently supported by the newspapers, he succeeded in forcing the question upon the attention of Parliament. In April, 1853, the House of Commons appointed a committee of seventeen members

to look into the management of the National Gallery, and to take evidence. Nothing came of the investigation, for, though the committee was not wholly what is called here at home "a whitewashing committee," yet it was of that nature, and the actual result arrived at can only appear from the reading of the testimony. If Sir Charles Eastlake had run away with the Channel Fleet or had allowed the army to be ingloriously gobbled up by the Cetewayo of the period, or had embezzled the Funds, he might have been made to feel in some mild way that he had not fulfilled the expectations of those who employed him, and he might have been retired on a pension or received a sinecure. But, so great was the indifference to art in England, and so few, even among the educated class, were capable of appreciating the situation we have described, that there was really no obstacle in the way of Prince Albert and his Germans standing by the court appointee and rewarding him for the loss of one office by giving him another and another.

The result of the investigation by the committee of the House of Commons into the condition of the National Gallery was such as to raise very sensibly, with that portion of the public really interested in the matter, the estimate of Mr. Moore's services and of his knowledge of art.* Only quotation, for which we hardly have room, would suffice to do justice to the extraordinary state of things laid open by the examination of the witnesses. It is only in England, surely, that servility could be carried to such an extent as it was on this occasion. Nothing could have been more damaging to his own professional reputation than the testimony that was wrung from Eastlake himself on this examination. He admitted that Claude's "Queen of Sheba" had been ill and tastelessly cleaned—too much cleaned; and that the "cleaned pictures do now very much want some of that *dirt* which they had before." He said that "one of the injured Claudes, an 'Annunciation,' No. 61, called by some, 'The Angel appearing to Hagar,' would be much improved if you were to take a little dust and rub that over it; that

* A friend pointed to one of the president's pictures, saying: "This is by Shee." "My dear fellow," said Lamb, "you mean 'by her.'"

* The Earl of Onslow in his will leaves Mr. Morris Moore "200 guineas in token of the high opinion I entertain of him as a consummate judge of pictorial art in all its various branches, and of that manly bearing which so strikingly marked his conduct throughout the tedious labors of the Committee of the House of Commons (1853) on the National Gallery Question."

that would do great good," and he recommended that it should be left without its glass for at least a twelvemonth, so that it might have the benefit of *dirt*; for "dirt," said he, "has the effect of glazing," etc., etc. And to conclude, he made the following confession: "I wish to state, as plainly as possible, that I might have prevented the purchase of the Holbein. I can hardly assume that such a director as I think fit for the National Gallery would make such a mistake."*

It was while this half-political, half-artistic conflict was raging over the affairs of the National Gallery, that an event occurred which was destined, in the end, to turn the whole current of Mr. Moore's life into another channel. This was his purchase at auction, at Christie's well known rooms, of a small picture by Raphael, the now famous "Apollo and Marsyas." Another man might have bought this same picture, and nothing particular would have come of it. If he had been a rich man, he would have carried it home and hung it up in his dining room, where, for the rest of his life it would have added a delicious zest to "the after-dinner chat across the walnuts and the wine." Or, if he had been an ordinary frequenter of sales, who had, at last, after years of waiting, secured a prize, he would have marched off to the National Gallery with it, and sold it to the Trustees at a bargain. But not thus did Mr. Morris Moore trifle with the gifts of the gods. In his hands the picture was destined to play a more important part: it was to become, for nearly thirty years, a touch-stone for the connoisseurship of Europe.

The singular chain of circumstances by which so remarkable a picture as this came into the hands of its present owner may interest our readers. The last owner of the "Apollo and Marsyas" before Mr. Moore bought it was a Mr. Duroveray, a person known to a small circle as a collector,

* Notwithstanding these facts, all matters of official record, it still remains that Sir Charles Eastlake bears for the world at large, and will always bear a respectable name. This is largely owing to his titles of Knight, President of the Royal Academy, and Director of the National Gallery, but also to his name being linked with certain dry-as-dust pieces of book-making which nobody ever reads, or needs to read, but which,—one of them at least,—are considered to add a certain weight to the conventional gentleman's library. He edited, with notes, his wife's translation of that portion of Kugler's "History of Painting" which relates to painting in Italy, he collected some essays toward a history of oil painting, and he edited a translation of Goethe's "Theory of Colors."

and who had valued it extremely, keeping it always in sight, but never, I believe, attributing it to any master in particular. The only other person to whom it is known to have belonged is John Barnard, one of the celebrated collectors of the last century, and a friend of Reynolds. His initials are to be seen on the back of the panel. I do not know whether Mr. Moore had seen the picture at the house of Mr. Duroveray, or whether he saw it for the first time at the auction room where that gentleman's pictures were sent to be sold after his death. The auction-room was Christie's, which is to the great metropolis of the world what the Hôtel Druot is to Paris, the place where the world of connoisseurs, amateurs, art-loving idlers and curiosity-hunters most do congregate, there to watch the wrecks of noble houses and private fortunes, and the madness of collectors, change hands and be dispersed. At these sales it is the old custom to allow the articles to remain "on view" for three days previous to the sale; but on this occasion the sale was postponed until the seventh day. This delay was, I believe accidental, nor have I ever heard any reason given for it. It is a fact, however, not without significance, that one of the most beautiful pictures in the world hung in a public room in London for seven days, where it was seen by many people whose business or pleasure made them constant visitors at Christie's, and yet, as the sequel will show, Mr. Moore carried off his prize almost without the show of opposition. Among the visitors was Sir Charles Eastlake himself, who passed the pictures in review, and, as he came to this one, dismissed it lightly with a "Very pretty picture, that," to the friend at his elbow.

This was, of course, excusable. How is a president of the Royal Academy, a director of the National Gallery, and an editor, with learned notes, of a German "History of Painting," to say nothing of the author of contributions to the History of Oil-Painting, to recognize a work by Raphael, unless it is attributed to that artist in the catalogue of the sale? What are sale-catalogues and museum-catalogues for, unless it be to tell people who do not know, just what articles it is safe to buy, and just what things it is safe to admire? And the bother of it was that, in the sale-catalogue, the "Apollo and Marsyas" was not attributed to Raphael at all. Consequently, the President of the Royal Academy had no clue at all to guide him in judging of this picture. When he

bought the "Portrait of a Medical Gentleman" by Holbein, for his National Gallery, he was not without a clue of some kind. He knew that it was by Holbein because it was signed by that master, though it did, unfortunately, turn out that the initials were, not only wrong, but forged, into the bargain.

Mr. Moore, however, carried his clue in his brain, and did not worry himself about the catalogue's sins of omission or commission. He knew as well then as every true connoisseur knows now, that the only proofs of authenticity worth having are contained in the work of art itself; that the only signature to be trusted is that of the master's hand, written in every stroke of the brush. He knew then, as a great many people know now, that "documents," "pedigrees," "certificates," no matter how much sealed and signed, can never be of the least value to a man who has learned to study pictures from the inside. Marshal all your documents; bring forward your real, circumstantial certificates; and then, if you can, supply the link that connects irrefragably your picture with your documents. It cannot be done. And, in any case, what has the real connoisseur to do with documents? If the picture says to his conscience, "I was never painted by that master," will he believe the papers? And, if the picture says to his conscience, "You know I was painted by that master," of what use to him is written testimony?

Mr. Moore has told me that, during the whole of the six days the picture was on view, he did not hear the name of Raphael—nor, indeed, for that matter, the name of any master—mentioned in connection with it. One day, however, he had a fright. There was a well-known picture-dealer in London in those days,—a coarse, uneducated man, but with some skill in his business,—whom Mr. Moore met one day at the foot of the stairs coming down from Christie's "big room," as he himself was going up. "Good day, Moore," said the picture-dealer. "Going up to see the pictures? They say there's a Raffle among 'em." For a moment, Mr. Moore's heart sank to his heels; but, on reaching the room and making the rounds, he could find no confirmation of the dealer's remark. When the day of the sale arrived, Mr. Moore did not judge it prudent to bid on the picture for himself, and he therefore asked a friend to bid for him. But, to his disappointment, his friend excused himself with many regrets, having already promised to bid for another person. The two sat

side by side as the bidding went on. "Tell me when you have reached your limit," said Mr. Moore, and when the word came, "I have gone as far as I can," "Then bid for me till I tell you to stop," said Mr. Moore. And, in the end, he became the possessor of the picture. When he had it safely lodged in his own house, Mr. Moore quietly informed his friends that he was the owner of a masterpiece of Raphael, painted in his best time, and in the most perfect condition.

The picture of which Mr. Moore now found himself the happy owner is painted in oils on a panel of poplar-wood $15\frac{1}{2}$ inches high by $11\frac{1}{2}$ inches broad. A dark band running from top to bottom on each of the sides diminishes the breadth of the actual painting by a considerable part of an inch, and covers the space that would naturally be lost in the shadow of the frame. The subject of the picture is the legend of the contest between Apollo and Marsyas for the victory in music, and the point chosen is where the god is calmly listening while his antagonist plays upon the pipe. Both the painting and the panel are in perfect condition: the panel has neither warped nor cracked, and the painting has never been so much as touched by the hand of "restorer," "cleaner," or "preserver." The work is executed in every part with the utmost care, and is elaborately finished throughout. The highest lights on the hair of the god, on his lyre and bow, and even some portions of the foliage, are lightly touched with gold. Raphael has, with his usual taste, chosen for the point of time, not the cruel end of the story, where Marsyas, suspended from a pine-tree, is flayed alive for his presumption, but the prelude to the tragedy, where, as in the antique drama, the victim, whose fate we all foresee, sits for the moment happy in fancied security. The story ran that Marsyas, coming to the plain of Nysa, met Apollo, who had made himself famous by his playing upon the lyre. Marsyas challenged him to a contest; the Nysians were chosen as judges, and the conquered was to be at the disposal of the conqueror. The result of the contest is differently narrated. According to Diodorus, Apollo began upon his lyre, then Marsyas played upon his flute, and the Nysians, never having heard that instrument, were so taken with it and with the skill of Marsyas that they had almost cried out for him. Then Apollo took up his lyre again, and this time accompanied it with his voice. Marsyas appealed to the judges to know if

this were fair, since the question lay between the flute and the lyre alone, and that Apollo was employing two arts against one. Apollo defended himself by the plea that he was doing no more than Marsyas himself, who, in playing on the flute, used both his breath and his fingers. The logic of the gods was fatal, Marsyas and the Nysians gave way, and a third trial was ordered, which proved fatal to Marsyas. Another writer tells us that in this third trial Apollo turned his lyre upside down, and having played wonderfully well upon it thus reversed, challenged Marsyas to do the same with his flute. And when he declared it was impossible, the Nysians, who saw with whom they had to deal, gave the victory to Apollo.

On page 25 will be found an engraving of the original drawing by Raphael for this composition, which has long been admired in the Collection of the Academy of Fine Art in Venice, where it is described in the catalogue as "a work of rare perfection, in which Raphael displays all his elegance." It is interesting to note the differences between the first intentions of the artist and his final conclusions. It is to be remarked that the figures in the drawing are precisely the same size as those in the picture, and here, as in the case of other drawings by Raphael, there is still visible the line of punctured dots about the figures which show that they were transferred directly to the panel. The difference in size between the picture and the drawing is made up by differences in the background. For the first time the two are now engraved in such a way as to show their precise relations.

In the drawing the composition is divided into two parts by a tree, as in Raphael's "Dream of a Knight" in the National Gallery. In the picture the tree is diminished to a stump upon which the god has suspended his lyre, while the bow, with its belt and quiver, lies at its foot. In the drawing Marsyas is given the ears of the satyr which he was described as being, in some of the earlier forms of the legend; in the finished picture, this trait has disappeared, and by giving Marsyas the compact vigorous frame of a young rustic, Raphael has made the issue between him and the god appear less unequal. In the beautiful coloring of the picture,—and the coloring is more harmoniously beautiful than anything I know in early Italian art,—the figure of Marsyas suggests an antique bronze of the best period. And to note one other essential difference between the picture and the

drawing, we find in the drawing the head of Apollo wreathed with victorious bays, whereas, in the picture the head of the god is crowned only with his luxuriant, lightly waving golden hair. Raphael saw that the contest not being yet over, the wreath would be out of place on the head of Apollo. Differences such as these are for the pleasure of the layman; artists will enjoy studying the entire change in the composition of the landscape by which light and air and space are given, and each of the figures is set in the relief that belongs to him.

Even by the aid of Mr. Cole's exquisite engraving, it is impossible for one who has not seen the picture to get an adequate notion of the perfection of the paintings, which unites with the most elaborate, minute, and painstaking conception and finish in the detail, a superb breadth and luminousness in the treatment of the whole. No wonder that an Italian, Professor Tommaso Minardi, wrote, after returning again to this most ripe and lovely creation: "Oh, Raphael, happy soul at home in Paradise, many times as I see thy picture, I find in it each time beauties never seen before." Walter Savage Landor wrote to Mr. Moore, on receiving from him a copy of the "Leader" of September 7, 1850, containing an engraving of the "Apollo and Marsyas," by John Linton, with a description and criticism of the picture by Thornton Hunt, "Many thanks for your present of the 'Leader,' containing a print of your inestimable Raphael. The picture is incomparably the most beautiful I have ever seen."

It was not to be expected that Sir Charles Eastlake and his friends would accept Mr. Moore's ascription of his picture or acknowledge its beauties. They had good reasons for feeling very hostile to Mr. Moore, and with all due recognition of their ill deserts, it must in truth be acknowledged that Mr. Moore had left no stone unturned to earn their hostility. He went into the fight with a good will, and he laid about him with youthful earnestness and vigor, and a hearty, honest English hatred of shams and lies. Something has been said about his temper, and it is true that in reading his deliverances on the subject, one is not struck with their going too far on the side of amiability. But something of the roughness of Mr. Moore's handling of his opponent is due to that "customary attitude" of the Englishman of which we have lately heard so much; something, too, is due to the fashion of the time.

Here is a pamphlet with extracts (they are the same that were presented by Mr. Otway in Parliament), relating to this subject, taken from thirty of the principal newspapers, weekly journals, magazines and reviews in England, and the general style of rebuke and denunciation of Eastlake, Nevins, Passavant, Waagen, and the rest is not different in kind from Mr. Moore's. No doubt, the English are more moderate now. Whatever Mr. Moore's roughness may have been, this must be remembered: he was never so much as accused, in the hottest of the conflict, of a false statement, he was never once caught tripping, he wielded a manly logic, and he showed a thorough preparation for the work he had in hand. And as for his "Apollo and Marsyas," there are no apologies or explanations to make. His enemies might hold their tongues about it, but in only one case did any person with even the shadow of authority about his name, venture to deny its authorship. The reason is plain. It having once been admitted by the Eastlake party, people with reputations to lose as critics, amateurs, or connoisseurs, were cautious in their denial of the conclusions of such an authority as Mr. Moore, because, if they distinctly denied the picture to be by Raphael, the question would at once be asked, "If not by Raphael, then by whom? No one was ever able to name this other man. And so far as I know, only one person attempted the dangerous feat. A German named Passavant, a *protégé* of Prince Albert, the guest in London of Sir Charles Eastlake, and the author of certain books, which are as inaccurate as they are dull, did, on first glancing at the picture, perceive, clever man that he was, that it could not be by Raphael, and declared, on a certain Thursday, his unalterable belief that it was painted by Francia. At this absurd announcement (for the picture bears not any resemblance to the manner of Francia), consternation must have filled the Anglo-German camp, and measures were taken so actively, that on the very next Monday Mr. Passavant declared that when, on the previous Friday, he had said it was his unalterable opinion that the picture must be by Francia, he wasn't thinking. It was now his belief that it might have been painted by Timoteo della Vite. This attribution was sillier than the other. Timoteo was a name almost unknown even on the continent at that time, and still less known in England; no picture of his is in the National Gallery:

and he was a painter of so little value,—as anybody may know who will study his works where they may best be seen, at the Brevia, in Milan—that those who did know anything about him, could only account for his being named on one hypothesis: Mr. Passavant had selected an artist of whom it was pretty certain no one in England knew anything, in order to make refutation of his theory difficult if not impossible. Mr. Moore might well be proud of the long list of names of men and women, distinguished for their rank, their learning, their accomplishment—Italians, Germans, English, French, Americans—bearing testimony to the beauty of his picture, and all without a dissenting voice declaring their belief that only Raphael could have painted it. But, I suppose, the owner of the "Apollo and Marsyas," like the owner of any priceless jewel, cannot feel the value of his possession greatly enhanced by the admiration it extorts. He knows very well, that whoever sees his Raphael cannot choose, but must admire, and has so exalted an idea of the perfection of his favorite painter, it is impossible he should think that anything said in praise of him, no matter by whom, can add one cubit to his stature. Yet there stands the testimony, and it may well be doubted whether any other picture in the world can show such an array of names so unanimous in the enthusiastic expression of their admiration. It is pleasant to record that some of the most forcible expressions of opinion come from Germans whose names carry weight everywhere—Friedrich Overbeck, Peter von Cornelius, Schnorr von Carolsfeld, Julius Hübner, Moritz von Schwind, L. Gruner, Jos. Böhm, Dr. G. Carus, Ernst Förster, and the engravers, Mandel and Edward Steinla. Overbeck, all his life a devoted student of Raphael, writes, in 1860, in a strain of almost lyric enthusiasm:

"There is no need of certificates, monograms, sketches or studies of any sort, to prove that this precious picture, the Apollo and Marsyas, is from the hand of Raphael himself. In this work the young master cries with a loud voice to all the world, in accents not to be mistaken: 'As here Apollo shows himself already sure of victory over Marsyas, so by my genius shall I surpass everything that has thus far been created in art.'"

And Cornelius, more tersely but with no less meaning:

"It would have been the highest good fortune for art if there could have existed another artist beside Raphael capable of having painted such a work."

The Italian names are many and important; but I need only mention the invitation to Mr. Moore from the Academy in Florence to exhibit his two Raphaels, "The Apollo and Marsyas" and the "Portrait of Dante" in their galleries; the request of the Pontifical government that he would permit his picture to be engraved under its authority in the government establishment; and lastly, the action of the government of the city of Urbino in setting apart a room in the house where Raphael was born, for Mr. Moore's use whenever he should visit Urbino, as a token of respect for one who had done Raphael so much honor. More important is the testimony of French talent and learning,—for with the connoisseur, the verdict of French criticism cannot be heard without respect, nor, were that adverse, would he greatly care what that of others might be. The best French critics accepted the "Apollo and Marsyas" at once, nor was there ever any opposition in Paris to its taking its proper place as a masterpiece of Raphael. Count Henri Delaborde wrote in the "Revue des Deux Mondes" for July, 1858, an article on the subject, in which the picture was most skillfully analyzed; and in the "Gazette des Beaux Arts" for July, 1859, the reader will find an etching of the picture accompanied by an article by M. Gruyer in which the cause of the picture and that of Mr. Moore are vigorously and skillfully defended. Articles appeared in all the leading Paris journals, the "Débats," "Siècle," "Constitutionnel," "Indépendance Belge," written by Délécluze, Tardieu and other well-known writers, while among the French artists Ingres, Flandrin, Delacroix, Robert Fleury and the engraver Henriquel-Dupont expressed their admiration of the picture in the strongest terms.

Nor have American artists been less outspoken. A recent expression of opinion on our side the water has been the earnest letters from Mr. Eugene Benson to the editor of the New York "Evening Post" (see that journal for June 20 and 26, 1879), thus fitly closing the list of American testimonials to the beauty and authenticity of the picture which was opened just ten years ago by Mr. James Jackson Jarves in his "Art Thoughts." Mr. Jarves gave an excellent description of the picture, and spoke in eloquent terms of its precious qualities. And Mr. Jarves' opinion is upheld by such excellent judges as Mr. George Inness, Mr. Elihu Vedder, Mr. G. P. A. Healy, and Mr. W. W. Story. Mr. Vedder writes to Mr. Moore, May 1, 1870:

"I have now seen this perfect picture, Raphael's 'Apollo and Marsyas,' several times, and each time with renewed enthusiasm. Like the 'Vision of Ezekiel'* I always remember it as a large picture, and am surprised at its actual size. In its perfect preservation it should be a lesson to modern painters. I regard it as simply one of the glories of the world."

One object in writing this article will have been accomplished if it should give to the many Americans who have seen the picture in Rome a fresh impulse to do something practical toward the purchase of it, for some one of our home Museums. Every American who has ever seen it has expressed more or less strongly the wish that it might belong to Americans, but as yet nothing has been done to make that consummation possible. I am myself convinced, and I have some reason for my belief, that nothing will come of appeals in its behalf to the "rich men" of our community.† If instead of being a consummate work by the greatest artist who ever lived, it were a picture by Gérôme, Meissonier, or some one of the notables of the hour, their coöperation might be looked for. But the purchase of the "Apollo and Marsyas," if it be accomplished at all, must be the result of a subscription among the not-rich lovers of art for its own sake, backed by the artists, who, besides the pleasure they would have in the possession, would find their profession strengthened in the affection and respect of the public by the presence of such a standard.

We cannot have an art museum without art, and art, properly speaking, means pictures and statues. Porcelain, pottery and majolica, carved ivories, fans, snuff-boxes, and lace are, or may be, artistic things, but they are subordinate, and ought to be kept subordinate to the main thing. Even if the improvement of the industrial arts be the chief thing looked to in the establishment of a

* The "Apollo and Marsyas" is of the same size as "The Vision of Ezekiel."

† Not because they cannot judge for themselves, but because they will not. As a rule they are in the hands of the dealers, and buy almost exclusively as they see their way to a good speculation. Mr. John Taylor Johnston is a black swan among our rich men, in that he has the good sense to take advice from those whom he knows to be good judges and disinterested. It is to his wisdom and liberality combined, that this community owes the Cesnola Collection, Turner's "Slave Ship" and the King Collection of gems.

museum, it is beginning at the wrong end to set first before the public and before our mechanics and artisans the subordinate forms of art. It is the Louvre, that glorious collection by the free gift of which to the people France proves her essential democracy—it is the Louvre, and not the Museum at Sèvres, that keeps up

whole public, rich and poor, learned and unlearned, will do more in a year to educate us in the enjoyment of art for its own sake than all the present contents of the Museum, valuable as they are, could do in a century—for the simple reason that, not being art, they could of course do next to nothing toward making us love it.



MICHELANGELO'S "VIRGIN OF THE LECTERN," OWNED BY MR. MORRIS MOORE, OF ROME.
(AFTER A DRAWING BY FRANCIS LATHROP.)

in France the race of potters who do her so much honor and increase her revenues; and it is because England has no Louvre, but only a South Kensington, that her potters and her "art" manufacturers generally are merely imitators and copyists, however clever or clumsy. It is only the highest art that has the power to create, and if we want to raise artists we must feed them on celestial food. The possession of one such picture as the "Apollo and Marsyas" of Raphael, by our Metropolitan Museum, free as that museum is henceforth to be at all times to the

Only a little room is left for speaking of Mr. Moore's Michelangelo, here engraved for the first time, "The Virgin of the Lectern." From a certain point of view a new easel-picture by Michelangelo is of almost greater value and interest than one by Raphael, because so few are known to exist. The best known is the "Holy Family," in the Tribune of the Uffizii at Florence, and the National Gallery of London has two others, both unfinished, "The Madonna and Infant Christ, St. John the Baptist and Angels," and the "Entombment

of our Lord." Of these the former is the more celebrated; it formed one of the principal features of the Manchester Fine Arts Exhibition in 1857, up to which time it had been attributed to Domenico Ghirlandajo. Mr. Moore was the first to accredit it to Michelangelo, to whom it is now without dispute ascribed. The present picture, which Mr. Moore has owned for many years, but which I never had the good fortune to see, since it was not in Italy at the time I was in that country, is, so far as I can judge from the photograph, a more interesting and characteristic picture than any of the others, certainly it is far more pleasing than the Florentine example, or than either of the unfinished pictures in the National Gallery. I take it to be a very youthful work, and find in the attenuated and writhing figure of the Christ child with his aged face, a reminiscence of the early Germans, as if it might have been inspired by Michelangelo's youthful study of Schongauer. It is, however, in this very figure that the student of Michelangelo will find the seal of the master, the type of much

that we meet afterward in the Sistine Chapel. The Virgin herself recalls the Delphic Sybil in the ceiling of the Vatican, and the St. John reminds us of the figure of Duke Lorenzo, "Il Pensiero," in the Chapel of the Medici. He holds in his hand the same little cup that he has in the bass-relief of the Holy Family in the National Gallery. The lectern at the left hand of the picture is of the same type as the candelabrum designed and executed by Michelangelo, which is one of two on the altar of the Chapel of the Medici. The picture is painted in tempera on panel, and has a diameter of 2 feet 2 inches.

Here are three pictures that would make any gallery that should contain them a formidable rival of the best collection in Europe. With the "Apollo and Marsyas," and the "Portrait of Dante," by Raphael, and the "Virgin of the Lectern," by Michelangelo, on its walls, the Metropolitan Museum of New York need not veil its head to the National Gallery; nor does any one gallery in Europe possess three such specimens as these of the skill of the two great Princes of the Kingdom of Painting.

GALATEA.

* * * * *

THEN thrilled with sharp remorse, he held her off,
So that the moonlight bathed the wondrous form
That quivered still with his last fond caress.

"And have I wakened thee to life and love,—
Life with its burden, love with thorny crown,
And death that puts an end to all fair things,—
Who might'st have stood in calm and stony grace
And perfect beauty all the ages through?
Forgive me, sweet!"

But while the first sad tears
Sprang to her eyes, and while her heart beat quick
For dread of all the untried years might bring,
She, woman-like, laid her warm lips to his,
And whispered soft:

"Be comforted, my own;
Could I have spoken, this had been my choice,
Since love atoneth both for life and death."

RARE LAWN-TREES.

WE have noticed in another place,* the existence of certain distinctions among plants that suggest in a certain way the differences between the aristocrat, the bourgeois and the peasant. Such distinctions may be fanciful,

but we think those who have lived among plants and have loved them will acknowledge the truth of the comparison. It expresses something which must needs be kept in view if lawn-planting is to be made effective. We desire now, therefore, to call attention

* SCRIBNER for June, 1879.

briefly to some noteworthy distinguished, aristocratic trees, specimens that any one would hesitate to obscure in a mass. For, essential as effective grouping may be, it can never rival in importance the graceful, majestic, or otherwise charming bearing of isolated specimens. The number of choice and peculiar trees is so great that we shall present only such as combine in the highest degree remarkable qualities of color and

Fruit-trees, as we all know, are usually and properly planted in regular orchards, and though often fine from an ornamental point of view, do not seem generally suited for the lawn. They may, indeed, be intermingled with lawn-trees by intelligent planters, who manage them with skill, but we feel, nevertheless, they are out of place.

The first of our illustrations, however, shows a highly ornamental example of the



THE DOUBLE FLOWERING CHERRY.

form. It is easy to find among plants either remarkable color or remarkable form, but to obtain hardy plants notably uniting these qualities in excellent proportions is a more difficult task. We have, moreover, thought it best to exhibit here specimens of these harmoniously developed lawn-trees in full maturity and great perfection. The illustrations here given are, in short, faithful studies of superior specimens of their kind. Indeed, we question whether it would be possible to find in America a dozen—no, half a dozen—specimens of either variety mentioned, equaling, not to say excelling, the trees illustrated. But what shall we consider first? Each is so fine in its own peculiar way, that we confess to a difficulty in establishing any claim to singular pre-eminence. Perhaps, however, it may not be amiss to look first at trees that are familiar under other and allied forms—not because we expect to find in them old friends, but because a new interest for lawn-planting may thus come to us, when we discover that such trees may be so grown as to deserve prominent positions on the lawn.

cherry. It will be noticed that it presents little of the appearance of ordinary cherry-trees, other qualities having become prominent as well as permanent in its character. It is a double flowering cherry doubtless derived long ago from some common cherry-tree that had acquired an abnormal habit of producing sterile and double flowers. Some twig or bud evincing this tendency has been grafted or budded on the ordinary cherry stock, and thus has been perpetuated a double flowering cherry that bears no fruit. There are many varieties that have arisen from these "sporting" proclivities of various cherry-trees, and we have chosen for our illustration a grand specimen of one of the most common, if not the best of these varieties. It is 50 feet high and 50 feet in diameter of foliage, and the trunk is 4 feet through as many feet from the ground. At least 35 years old, it has all the picturesque contours of trunk and branches that characterize the common fruit-bearing cherry-tree of that age, with none of the decrepitude apt to appear at the same time,

especially in America. Spreading abroad great branches with bark ridged and furrowed, and possessing an outline both bold and picturesque, it would be a fine tree even if these were its only good qualities. But one more, at least, it has in full measure, for truly the innumerable flowers covering its entire exterior surface make a crowning glory for several weeks in the spring. These flowers are, moreover, larger and purer in color, and inclined to remain longer on the tree than those of the common fruit-bearing cherry.

brought to America from Japan. Indeed, we are not aware of the existence of any good specimen except the one to which we refer. We would not, of course, intimate that this tree may not have existed in America years ago, for it is surprising how plants creep into a country and remain undistinguished for years. Yet, practically, they do not exist because their merits are not recognized and employed. The specimen in question is moreover remarkable, not because there are no other weeping

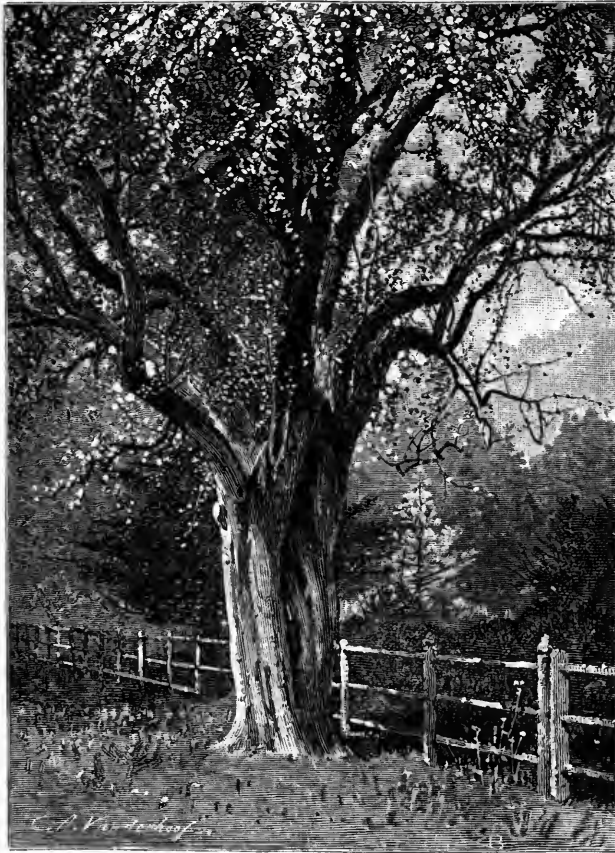

THE ENGLISH HAWTHORN.

Another cherry-tree to which we are constrained to refer in connection with the flowering variety has, in its peculiar weeping form, an equally ornamental habit. To secure the recognition of the special habit of weeping trees, they should stand apart from others, if not in distinguished positions. We know little of the character of this weeping tree farther than its general appearance and behavior for the three or four years since it was

cherries, but because it is entirely different from any other weeping form of that tree. Barring this tendency, it is a common, hardy cherry, only with the branches reversed in growth and the leaves somewhat elongated. Other weeping varieties are either small and round-headed or in some way differ completely from the common fruit-bearing cherry-tree. Here, however, we have apparently the common cherry with

grotesque and vigorous branches sweeping down to the ground and closely enfolding the stem. The specimen referred to is, indeed, only a young tree eight or ten feet high, but if it is thus picturesque when young, it must certainly possess greater attractions when older. Its vigor, moreover, as a weeping tree gives it still further value, for save certain willows and poplars,—trees of short-lived beauty at best,—we hardly know of a rapid-growing weeping tree. Fortunately, this new cherry can be readily budded or grafted on the common cherry stock; we may, therefore, soon expect to see it generally propagated and employed. The Japanese are said to consider it their choicest weeping tree, and when in full bloom it certainly presents a lovely appearance. The flowers are smaller and not so white as those of the common flowering cherry.

Our next illustration shows the hawthorn, —*Cratægus oxycantha*,—one of the common trees that may be found on almost any lawn either in proper person, or represented by some closely allied variety. Why then does this picture seem extraordinary to us? Simply because in America a vigorous, healthy thorn is an uncommon sight. It is a pity that blight should strike the hawthorn in this country, for every one knows that one of the most pleasing features of rural England lies in its charming hawthorn hedges, trees and flowers. Sweet at spring-time and rich in summer, they are associated with perhaps the loveliest country walks in the world. We should like to be able to tell how to grow a good hawthorn in any sure fashion. A dry, light soil should be avoided. The pruning must be decided and thorough, though not too severe. But after all you must take your chances to a certain degree and thank your stars if you get a really good specimen. In point of fact, the hawthorn thus healthy and thus developed is a choice and rare tree in America. Englishmen that know well the hawthorn of their own country have stood before the specimen here pictured and declared that it would be even in England a very noteworthy tree of its kind. Its history, doubtless, dates back many generations, and the wonder is how it has lived and thrived so long. It must have been veritable British land in which it was planted along the old king's highway. Indeed, the old road, on the border of which it stands, was in early colonial times the main road in Flushing going east-

ward. The fact that this tree is one of the oldest features in the neighborhood, its peculiar habit and the rare occurrence of any choice specimens of its kind, all contribute to lend it a special interest among even the rarest trees. In itself, moreover, it is a curious and picturesque tree. The general effect produced by its form is that of enduring, firm, compact vigor. Trunks and branches are all ridged and furrowed, gnarled and twisted, but not seemingly stunted. On the other hand, they seem to enjoy a hale and rugged old age, pleasant to behold. The white flowers still put forth every year as profusely and as charmingly as they probably did a century ago, and are certainly as sweet-scented and delightful. But the practical question is, Can the hawthorn be made to live and thrive on our lawns? Unquestionably, if you give it rich, loamy soil, and prune systematically while young without cutting away too much wood and thus weakening and exposing it to the attacks of blight, etc. Besides, supposing you should lose, for one reason or another, three out of four plants,—an unnecessarily extreme supposition,—is not the enjoyment of the beauties of the fourth well worth the sacrifice?

The next illustration represents the picturesque and remarkably effective masses of the



CEDAR OF LEBANON.

cedar of Lebanon. The association of the cedar of Lebanon with Biblical scenes and history would alone secure for it the deepest interest. Possibly no tree grown in America surpasses it for the breadth and picturesque character of its dark masses. We refer, of course, to a tree in full maturity, like the specimen represented. When younger, the branches frequently stand more upright, and the forms are less massive. The original of this picture is in Flushing, near the old homestead of Hon. L. B. Prince, where it has stood at least fifty years. In other parts of the country, equally fine and possibly better specimens can be found, but this one is very noteworthy and well fitted to illustrate the peculiar appearance of the tree. Good specimens in this country are rare. It is not that the plant is tender, when well established, but that want of protection while young exposes it to occasional injury, if not death, from cold and from peculiar changes in early spring. We have often noticed with much interest and regret how the choicest specimens seem to fare the worst in the character of the positions selected for their occupation. What the cedar of Lebanon needs is complete protection on all sides with trees and shrubbery which are yet far enough away to afford light and room for growth of roots and branches. When it has reached a height of eight or ten feet, it will, in all probability, take care of itself and present a picturesque beauty that will fully repay the necessity for cutting away the shrubbery about it.

Thus far we have dwelt on trees that in some of their forms are tolerably familiar to tree lovers, but we come now to a group, the individual members of which present in every case a choice, unfamiliar and strikingly distinct form. Let us look at the illustration on page 39, which represents an existing group. Were ever trees of such diverse appearance gathered together? Note the grotesque spreading branches of the ginkgo, with its triangular, light-colored leaves, resembling some great maiden-hair fern. Then, on one side, as if endeavoring to present the utmost contrast, appears the weeping sophora, dark, green, symmetrical, assuming forms that, when clothed with foliage, are anything but grotesque. This plant constitutes the central and most interesting part of the picture; and close by are arranged erect, pyramidal dark green, Irish yews and the round-headed, light-colored cephalotaxus. These trees are

valuable in other ways than that of the capacity for grouping well together. Two members of the group, viz: the ginkgo and the weeping sophora, are from Japan, the country which sends us so many of our best hardy ornamental trees. The ginkgo is perhaps one of the most anomalous and curious of all ornamental trees. It is a true deciduous tree, and yet a conifer. With leaves resembling fronds of maiden-hair fern, the branches are invariably strong, massive and vigorous. The leaves remind one somewhat of small, awkwardly shaped palm-leaf fans. The color, too, as well as the form, is distinct, being a light shade of green of a peculiar type. Indeed, in making up this tree, nature seems to have brought together an assemblage of unexpected qualities, which not only produce an interesting plant, but a bold, picturesque feature on the lawn. To obtain the full effect of its large and striking outline, you must view it relieved against an open blue sky. The illustration shows it in this manner, and if such arrangement be impossible, pains should be taken to give its great form abundant room to develop. The wood, or rather bark, is of a light, yellowish green. But we must not linger too long over the ginkgo, extraordinary as its qualities are, for in the essential beauty and attraction of the best type of lawn-trees, it cannot equal the weeping sophora. This we say, knowing that the ginkgo is hardier and more easily grown from cuttings and seed than the weeping sophora. One seldom sees a good specimen of this tree in America; it is more common in Europe. In fact, the specimen illustrated is one of the few well-developed weeping sophoras now existing in America; all, or almost all, high grafted specimens are imported. Our summer suns and sudden changes of weather seem to crack, blacken and destroy the stem of the stock *Sophora Japonica* before it attains the desired height for grafting, which is about seven feet. Importing, however, is hazardous, for the roots are destitute of fiber and peculiarly susceptible of injury on the voyage. It may readily be conceived that such plants are difficult to transplant successfully, and take long to recover their original beauty. The stems of many specimens of the weeping sophora are so crooked that the percentage of well-developed plants is still further reduced. In America, on account of the same hot suns and sudden changes, a system of low grafting for such trees will doubtless become more and more popular

every year. But the specimen we are considering is grafted on a stem at least seven feet high, straight and well developed. Indeed, it is well known that crooked stems of all trees straighten as they grow older.

Setting aside these difficulties of transplanting and establishing the weeping sophora, nothing can surpass it for symmetry, fine coloring and the other good qualities that pertain to the best umbrella form of weeping trees. The leaves, suggesting somewhat those of a pea vine, small and of perfect outline, are numerous disposed in regular garlands that droop in graceful curves to the ground. In the older wood, the short, sharp, vigorous curves are very remarkable. For roundness of general habit and a beautiful regularity

shown in the picture on page 40 of a dead specimen of what was probably the largest tree of its kind in America. Although, at least, 35 years old, its height was not over 10 feet. It died from transplanting; but the rugged and remarkably curious forms still attest the extraordinary development it had already assumed.

The remaining members of the group are perhaps less striking than the sophora and the ginkgo, but each in its peculiar way is valuable as an ornament on the lawn. Of the two, the more remarkable is the Irish yew, a valuable member of a genus of conifers that offers many richly colored and strangely diverse forms. In England they are hardy and very generally employed; but



GINGKO TREE, IRISH YEW, AND WEEPING SOPHORA.

in the arrangement of the foliage, no tree on the lawn is more admirable. The space underneath the foliage and adjoining the trunk also makes an agreeable bower where the sunlight filters through in minute quantities. In this bower, too, you may note with wonder the curiously gnarled and twisted forms of its peculiar anatomy which is outwardly covered with rich foliage. These picturesque and grotesque forms are

in America, like the sophora, they suffer more or less from the cold while young. Large specimens all over the country seem to stand well. They must therefore be planted in protected positions after the manner suggested for the sophora. The Irish yew is the darkest-colored evergreen we can call to mind. Glossy green in reality, it appears at a short distance almost black, an effect which is probably increased by the solid

fashion in which the foliage is massed. Its outline is erect, pyramidal, columnar, we had almost said square, in certain parts of the contour. It would be difficult to conceive a more intensely concentrated and individual tree, and the contrast it affords to all other trees is very noteworthy. The three yews as they stand in the illustration, though small, immediately arrest and impress the eye. It



DEAD TRUNK OF WEEPING SOPHORA.

is not often that winter even browns the foliage of these particular specimens, and yet we know of very few other large ones about the country. We wish Irish yews could be employed more generally. Methods to secure their safety could surely be devised. The slowness of growth of Irish yews, and indeed of all yews, specially fits them for certain peculiar and characteristic kinds of

lawn-planting. As an illustration of this, we may cite the specimens here presented, which are probably 25 years old though not four feet high.

The cephalotaxus, a form allied in appearance to that of the yew, constitutes another element of the picture, and completes and perfects by contrast the charming qualities of the other trees. It is round headed, a hemisphere almost, and with light-colored foliage. The leaves or needles—for it is an evergreen—lie in more or less horizontal positions and thus contrast strongly with the erect forms of the Irish yew. Indeed it bears much the same relation to the Irish yew in general appearance as do the curves of the sophora to the eccentric lines of the ginkgo. The relations of the two pairs are farther

perfected by the fact that the first two are evergreen and the second deciduous. Color, as well as form, is also remarkable in the cephalotaxus, which is entirely distinct in general appearance from all other evergreens. A little protection while young is likewise beneficial to this tree. Its attractions, however, will amply repay any care it may require. In short, we might as well say once for all, that the lawn-planter who desires to ornament the lawn with really choice distinguished specimens must expect to nurse them carefully by planting near by groups of deciduous or evergreen shrubbery. Even then he will lose a plant now and then. If he is willing to take no risk his list of plants suited to American changes of climate must be comparatively small and devoid of some most interesting trees. Indeed, if a lawn be planted well and liberally at first with skirting flowering shrubs and choice trees, all perfectly hardy, the general effect on the main lawn will be little injured if now and then a beautiful specimen dies and is replaced.

The great value of Japanese plants for the lawn we have already seen exemplified by the appearance of two extraordinary plants in the last-named group. It may not therefore be amiss to look at two or three equally attractive specimens which come from the same or nearly the same quarter of the globe. In many ways, the Japanese maple is perhaps the most extraordinary of these plants. We have scarcely known it in America until very recently; but already many recognize its great charms and special qualities for some peculiar

offices of the lawn-tree. The illustration hardly does it justice, for it is impossible to delineate with only white and black anything like its delicacy of coloring. We may admire in the picture the distinct and attractive forms of the small indented leaves and the fine effect of their masses and outline; but we gain in this way no conception of the beautiful coloring of the eccentric growths which show on many individual leaves purple, pink, and even white, richly and delicately combined with green. The heat of midsummer dulls these beautiful tints; but in June or October,—in the one case on the fresh young growth, in the other on the decaying leaf, the variations of color are subtle and wonderful. It is, moreover, a slow grower, having attained its height of eight or ten feet during a space of not less than 20 years. This particular species of Japanese maple is termed *polymorphum*, "many-formed," and is a special favorite with the Japanese under the myriad guises it assumes. The plant in the illustration is a specimen of *Acer polymorphum* simple and pure, but at least twenty varieties of this parent are cultivated in America to-day. So diverse are these many-colored and many-formed varieties that one can scarcely believe that all come from the species before us. Yet you may see any day on the specimen figured, particularly in June during the freshest growth, a score of "sports" or leaves varied from the original type in a very marked degree, so strong is the inherent tendency of the plant to diverge. We wish we could show you some of these marvelous varieties. The variation of form extends from the extreme of dwarfness, two feet high at twenty years old, to the larger type of the parent, and the leaves are cut and divided into every conceivable shape, in some cases until they are mere shreds of tissue. But color lends the highest charm to the Japanese maple, and its variation on the leaves seems infinite. Pure white, bright red and green mingle on the one surface and shade off into each other with delicate and exquisite gradations. Especially on the small-leaved kinds do these variations continue, and a plant with lace-like foliage may have one part pure white and another entirely green. And the strange fact about these tropic-hued plants is that they are perfectly hardy, as hardy as any of the American maples. For miniature lawn-planting nothing can be better adapted than these exquisite qualities of the Japanese maples,

and their general employment will help to lend a brightness to the appearance of the lawn now almost entirely accomplished by the occasionally crude colors of bedding plants. As yet the Japanese maples are



JAPANESE MAPLE.

extremely rare, but good judges have not hesitated to assert that they will exert considerable influence eventually in changing the imperfect methods of lawn-planting now in vogue. The next illustration, also representing a tree originally derived from the East, gives one of the most remarkable specimens of *Magnolia Soulangeana* in the world, and doubtless the best in America. It is twenty-five to thirty feet high, and as much if not more in diameter, with four distinct trunks or branches starting from the low-set graft, which are each at least one foot through. To one accustomed to see only young magnolias five to six feet high, the leaves seem somewhat strange in form, and the firm, enduring vigor of the native wood is very different from the soft and somewhat spongy nature of earlier growths. Indeed the rich gleaming glossiness of the large foliage and the unusually rounded smooth forms evident everywhere, make it a very remarkable tree. It looks more like some tropical product than a choice hardy tree of the north. *M. Soulangeana* does

not, perhaps, equal *M. conspicua* in beauty of flowers, but it is more vigorous always, and often in its maturity more picturesque. It was originally derived some 60 years ago from seed which was produced by the proximity of a specimen of *M. conspicua* to another of *M. purpurea* on the ground of Mr. Soulange at Fromont, near Paris. Although a hybrid, it does not, however, inherit the tender nature of *M. purpurea*,

pyramidal softened down. Its form, torch-like in contour, stands out sharply against the sky. But no pencil can portray the wonderful charm of the coloring and texture of the foliage. We know of nothing so perfect in its way. The color is a light tender drab or pea green, so delicate and soft that it tones down sensibly the decided outline of the tree. This mistiness and seeming unreality of interior composition is increased

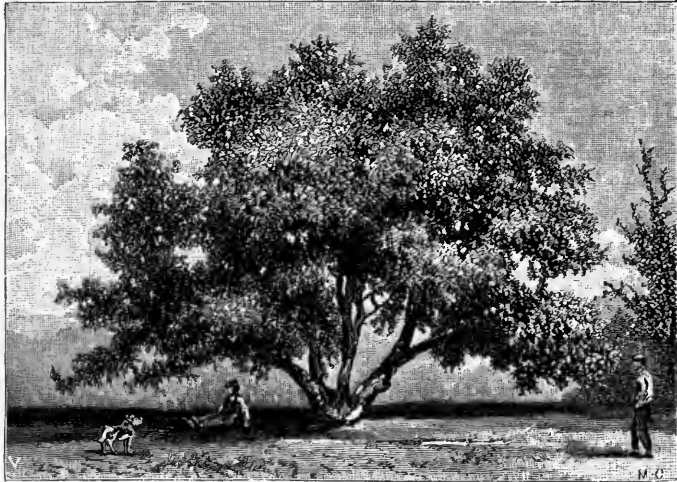

SOULANGE'S MAGNOLIA.

but is at least as hardy as *M. conspicua*. Both *conspicua* and *Soulangeana* are indeed perfectly hardy in America when once thoroughly established. But it is always well to give them a little protection with evergreen boughs during at least one winter after transplanting. Magnolias are among our choicest and rarest plants, ranking with rhododendrons, azaleas, and Japanese maples. To transplant them is somewhat difficult, especially if they have been standing long on the same spot. With oft-transplanted magnolias, most difficulties vanish, and removal becomes much like that of any ordinary tree. The original of our illustration stands in a prominent place on the lawn of Mrs. Leavitt, in Flushing, L. I., and in the spring is covered with thousands of large purple flowers.

In the weeping Chinese cypress, we meet still another native of the East, although it is also hardy in America and well worthy of general employment. Like many other choice plants, however, it is difficult to propagate, and partly on that account seldom seen. The picture indicates well its elegant pyramidal outline with all angles of the

by the peculiar formation of the leaves. They are like Southern cypress leaves, rolled each within itself until they have become delicate green cords swaying in the lightest breeze.

The effect of this peculiar foliage is very charming, especially as relieved by the reddish bark of the trunk, which is arrow-like in straightness. Although Chinese, it is evidently closely allied to our Southern cypress. The seed of this tree fails to come true to its kind, and grafting must therefore be practiced. It transplants well, and is hardy, but on account of its light wood may be moved more safely in spring than in fall. It loves moist spots, and does not thrive well in dry, sandy land. Many of its qualities as a street tree are excellent, but unfortunately road-sides are generally dry and unfitted for its growth. Except for this, and the fact that it leaves out late in the spring, being deciduous, we scarcely know of a tree so valuable and charming in every way. Our specimen in the illustration is forty feet high and about thirty years old, hence its vigor must be considerable,—sufficient for the most prominent lawn-tree.

The weeping larch of the next group of choice trees brings us back once more to familiar forms—familiar and yet how strange! The well-known larch leaves are evidently there, yet borne on what grotesque and uncouth branches! Great arms extend laterally until one looks to see them break down beneath the weight of the first heavy fall of snow. Most plants grow in some systematic or settled manner, but the weeping larch is a law unto itself. One would think the immense linden, near at hand, growing ninety feet high, would tend to diminish the vigor of such parts of the larch as are immediately under the influence of its dense shade. But no, it pushes out as decidedly and strongly in this direction as in any other. It has evidently been grafted high, some six feet, but whence its eccentric nature is derived, who shall say? It does not certainly suggest the growth of the European larch as we generally see it. Some strange abnormal form must have been perpetuated in a very complete manner by grafting. This particular specimen is the largest we have ever seen. The trunk is of moderate size, scarcely one foot in diameter, but it is nevertheless at least thirty years old.

We come now to an evergreen, which the larch is not, though it looks like one. *Picea Parsonsi*, *lasiocarpa*, *Lowii*, and possibly some other synonym, is a Rocky Mountain silver fir, a variety of *P. grandis*, one of the noblest evergreens of that region of noble trees. The specimen delineated stands in Flushing, on the grounds of Mrs. Leavitt, and is the finest in every way, as we believe, in America. No comparison should, of course, be made between it and native specimens. Their development and habits are utterly different. If native trees are sometimes more picturesque, they have never that perfection of detail exhibited by the cultivated plant. Different seedlings from the same Parsons' silver fir present different colors and forms, but the best forms are marked by a strong upward curling of the leaf. The blue, silvery lining of the lower surface thus exposed gives a beautiful variety to the general coloring. It will be noted also that the symmetry of this tree is perfect, the branches extending regularly out almost at right angles to the trunk. Nearly all the beautiful Rocky Mountain evergreens have been introduced within forty or fifty years. This specimen was obtained from about the first lot of *Picea Parsonsi* seed that produced any plants worth mentioning.

The date of its birth was nearly thirty years ago. Yet, for the kind, it has grown well, and is probably twenty-five feet high. Everything about its appearance is solid, rich and picturesque, the masses being peculiarly interesting and attractive; but the finer forms are extremely rare, and can only be secured satisfactorily and with certainty by grafting with cions taken from the best trees. Seedlings are very unreliable, and often run into far less beautiful forms than that of the illustration. Grafting, however, the only practical method of propagating it, is difficult, chiefly because little wood fit to produce fine trees can be found on any plant, and the plants from which to cut are themselves scarce.

To the right of the Parsons' silver fir, in



CHINESE CYPRESS.

the clustered studies of specimens, is a unique plant of the weeping Norway spruce, *Abies excelsa inverta*, one of our best weeping evergreens. It represents, perhaps, the extreme form of the graceful that a tree can

attain without lapsing into the grotesque. The larch just noticed is unquestionably grotesque, but, on the other hand, the thoroughly pendent grace of the weeping Norway spruce has a method in its *abandon* which is simply beautiful. Suggesting the general habit of the Norway spruce, the branches droop in picturesque folds, closely enveloping the stem, and now and then bursting forth in upward eccentric curves, as if overflowing with vitality. This peculiar and picturesque growth confines itself in this case rather more to the younger and upper part of the tree, for the reason that it has been left without pruning and training during its younger days. The graceful formation of the weeping spruce is made still more valuable by its perfect hardiness, fine transplanting qualities and moderate growth. Our illustration presents a specimen about

twenty-four years old, and nine feet high. During early life the weeping Norway spruce is much aided in attaining its finest habit and a definite symmetry, if it be carefully and systematically trained to a stout stake, and also pruned with judgment. For want of such training many weeping evergreens, and deciduous trees for that matter, fail to attain the symmetry and picturesque beauty they might otherwise have. The narrow columnar beauty of the weeping Norway spruce, as well as its moderate growth, specially fits it for the ornamentation of cemetery lots.

We pass on to the last and perhaps best member of our somewhat heterogeneous collection of distinguished lawn-trees. Yet how can we do justice to this specimen of a weeping beech! The picture expresses much, and we may tell you it is 50 feet high and 50 feet in diameter of foliage, the largest weeping beech in America, a Gothic cathedral in similitude, equal in itself to a grove of choice trees,—and yet you cannot conceive



PARSONS' SILVER FIR, WEEPING NORWAY SPRUCE, AND WEEPING LARCH.

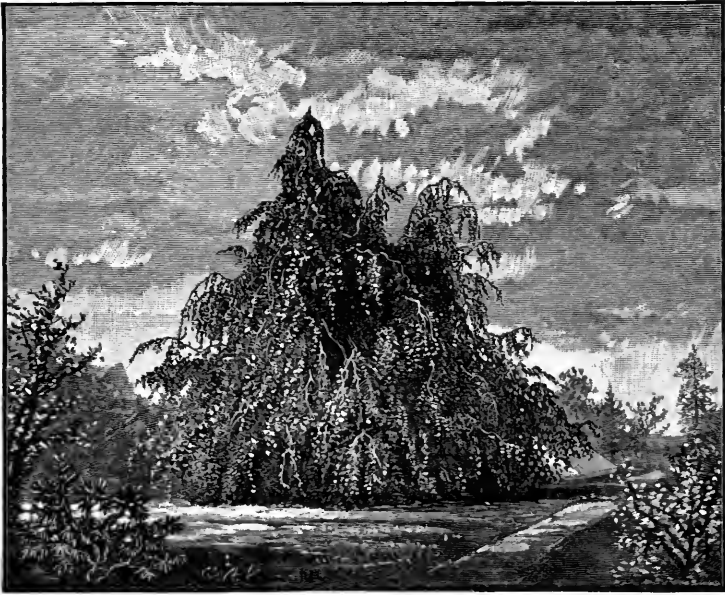

WEEPING BEECH.

its beauty in any adequate degree. The only way this can be done is to stand before it at sunset, when the noble outline cuts itself sharply against the evening sky, and the lights and shadows are clearly defined.

Our sense of its great size, charming as well as imposing, increases as we gaze. Its recesses and brighter parts become more picturesque, and we are impressed more and more by the beautiful eccentricity of



WEEPING BEECH IN WINTER.

Square. Every cubic foot of this vast volume of water contains nearly two cubic inches of sand and mud. Enough earth matter, it is estimated, is annually thrown in the Gulf to build a prism one mile square and 268 feet thick. The comparative volumes of water flowing through the three passes are approximately as follows: South-west Pass carries fifty per cent.

each pass) about 1,200 or 1,500 feet wide in the two large passes, and 600 feet wide in the South Pass, and the depths are about fifty feet in the large passes and thirty-five feet in the South Pass.

The banks, although composed of the deposits of the pass itself,—sand and clay,—are sufficiently tenacious to confine the water, and thus give it the requisite scouring

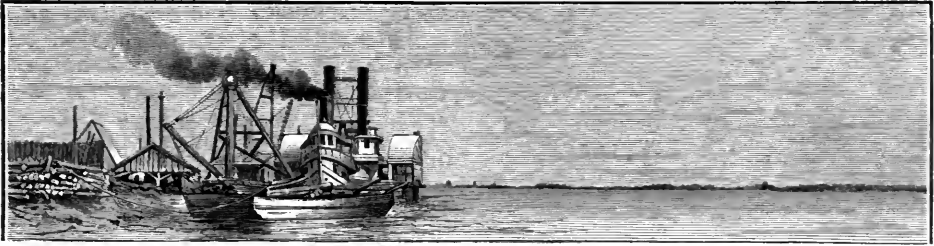

WORK-SHOPS, DERRICK, DREDGE AND JETTY TUG, PORT EADS, LOOKING DOWN THE PASS.



LOOKING OUT TO JETTIES FROM PORT EADS.



PORT EADS FROM WEST JETTY CONCRETE WHARF.

of the whole river, Pass à l'Outre forty per cent., and South Pass ten per cent. The accompanying map of the delta will give a clearer idea than any verbal description can do of the relative positions and lengths of the three passes. At the mouth of each pass is a bar over which there is more or less depth of water. At South-west Pass the depth of water on the bar is about thirteen feet, at Pass à l'Outre it is ten feet, at South Pass, before the construction of the jetties, it was eight feet. The crests of these bars are not immediately at the end of the land, but from two and a half to five miles out in the Gulf. Through the whole length of the passes there is a deep channel (uniform for

power to excavate and maintain a deep channel, but as soon as this confined volume reaches the land's end of the passes, it spreads out instantly to the right and left, and, losing a portion of its velocity by this diffusion, is no longer able to carry all its sediment, but drops it upon the submerged banks.

The central thread of the current, however, maintains its velocity for some distance into the Gulf, but, gradually losing it, scatters its load of sand and clay over a wide plateau. New floods coming down bring more sediment, which is deposited further out than that of the preceding flood, and thus the bars for all time are advancing

with more or less rapidity into the Gulf. At the South Pass, this advance was at the rate of about 100 feet per annum; at the South-west Pass over 300 feet per annum.

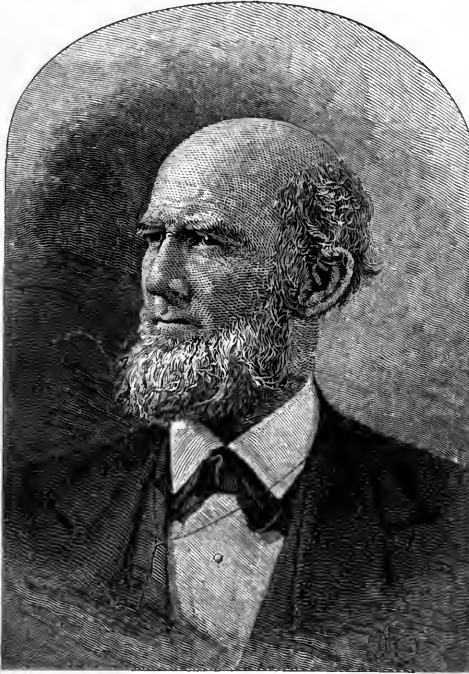

CAPTAIN JAMES B. EADS.

Within the conditions of the difficulty to navigation at the mouth of the Mississippi has been found the clue to its solution; for just as fast as the pass builds the bar out into the Gulf, just so fast it excavates a channel behind it. So that at the South Pass, for instance, while one hundred feet was each year added to its bar,—located two and one-quarter miles from land's end,—it at the same time added one hundred feet to its banks, and thus confined the water sufficiently to deepen the new channel during the year to the same depth found elsewhere in the pass. Captain Eads, catching this suggestion from nature, reasoned that if he could extend the banks of the pass, not gradually at the rate of 100 feet per annum, as nature was doing, but immediately two and one-quarter miles out over this bar into the deep water of the Gulf, he would produce sufficient power to excavate not only the 100 linear feet per annum, which nature was doing, but the whole length of the bar from thirty feet depth at the land's end to thirty feet in the Gulf of Mexico.

Although the bar extended out from the end of the land two and a quarter miles, yet the depths of water found at different points varied greatly. At half a mile from the land's end, it was about twenty feet; at one mile distance, it was fifteen feet; at one and three-quarter miles, it was ten feet; and from this point to nearly the outer edge of the bar, it varied from eight to ten feet, with a somewhat slighter depth at the crest of the bar. From this point there was a comparatively rapid descent into the deep water of the Gulf.

Lying in front of each of the passes, especially those which carry the largest amount of sediment to the Gulf, is found a peculiar formation called "mud lumps." Various theories as to their origin have been advanced. One is, that the decomposition of organic matter brought down in the sediment of the river generates gases which cause an upheaval, throwing the overlying strata in some cases out of the water, to a height of ten or fifteen feet. Another theory is, that the pressure of the superincumbent mass of the deposits on the landward side of the crest of the bar, forces up these ridges and lumps which lie in the softer material outside, and in the line of the least resistance.

There are some phenomena connected with the tides and the Gulf which deserve mention, for they exert a very important influence, not only upon the channel between the jetties, but upon the Gulf bottom beyond. For about 250 miles along this coast, the tides are diurnal—a phenomenon to be found nowhere else. Their average rise and fall is only about fourteen inches, though, of course, extraordinary storms and unusual conditions of other kinds will produce a greater range. The winds, which during the fall of the year have very much the character of trade winds, blowing from the north-east, affect the currents of the Gulf so that there is at times a current of from one to two miles an hour flowing to the westward. At other seasons of the year, when the wind is from the westward, there is a decided current setting to the east. During seasons of calm weather, however, no perceptible current exists. It has been suggested with some reason, that the water along the shore of the delta is influenced more or less by an eddy of the Gulf stream. The in-coming and out-going tides which, according to the investigations of the United States Coast Survey, approach the delta from the south-east, are

also another cause of a current sweeping past the mouth of the river. The storms of the Gulf, especially in the fall of the year, at times cause extraordinary currents. It will be noticed by an examination of any map of the United States, that the mouths of the river are thrown out about 100 miles from the main shore line of the Gulf. They are themselves huge dykes built out into the currents and counter-currents of the Gulf.

Having thus briefly described the mouth of the river and its bars, let us see how great an obstacle they have hitherto been to the development of the Mississippi valley.

The Mississippi River may be justly considered as the trade outlet of a vast empire. The tributary region, having an area of one and a quarter millions of square miles, is more than equal to the whole extent of Europe, leaving out Russia, Norway and Sweden. This area has a population of at least twenty millions, and produces yearly about one billion bushels of cereals, two million bales of cotton, and two hundred thousand hogsheads of sugar. A large part of this agricultural district is so far distant from the markets of the eastern sea-board, that its products do not prove profitable if transported by rail.

The development of the valley resulted

l'Outre. At one time provisional jetties were attempted, but the project was abandoned for want of means. Expensive dredge-boats were constructed by the government to work on the bar, at an annual cost of about \$250,000, and according to the report of a board of United States engineers, there was in 1872 and 1873 a depth of from thirteen to twenty feet on the South-west Pass bar, but the hope was not encouraged that a channel could be maintained of more than eighteen feet depth.

Meanwhile, the tonnage of vessels importing and exporting between the eastern seaboard of this country and foreign ports, had largely increased, so that a ship of from 1,200 to 1,800 tons burden was the ordinary size; yet the average size of vessels entering the port of New Orleans, prior to the opening of the mouth of the river by jetties, was not over 700 tons. During all the previous years, both before and after the attempts to open it by dredging and other means, it was the exception rather than the rule, for a loaded vessel to pass over the bar without detention.

This was the condition of the bar, and such were the obstructions to commerce, when, in the winter of 1874, Captain James B. Eads appeared before Congress and offered

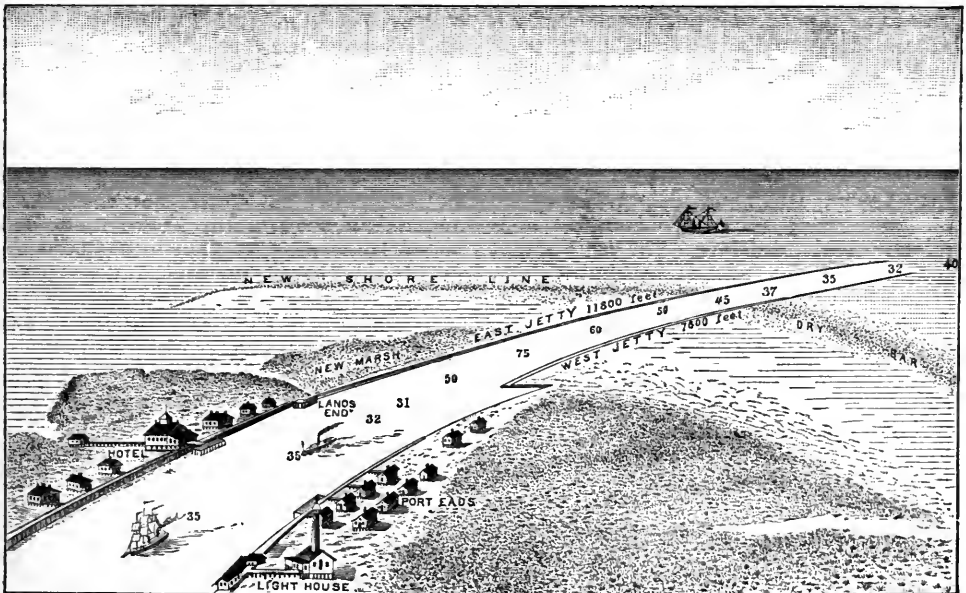

BIRD'S-EYE VIEW OF THE JETTIES. (THE NUMBERS REFER TO THE DEPTH OF FEET IN THE NEW CHANNEL.)

from time to time in the improvement of the river and its tributaries. Since 1839, efforts have been made to deepen the channel at the bars of South-west Pass and Pass à

to open the mouth of the river by jetties, stipulating that he should take no remuneration for his work until a channel from the deep water of the pass to the deep water of the

Gulf had been secured. The maximum depth to be obtained was thirty feet; and neither that nor the intermediate depths was to be paid for until the work was complete. Although offering to do this work at his own risk and expense, he met with a most determined opposition, both from government engineers and from the very section of the country which would be most largely benefited by a deep channel to the Gulf. The people seemed to have become indoctrinated with the belief that an expensive canal, and not an open river mouth was the best solution of the problem.

Captain Eads and his opponents before Congress held views diametrically opposed to each other. General Humphreys, the chief of engineers, in published pamphlets, and, moreover, in statements before the Congressional committees, contended that it would not only be impossible to build jetties and maintain them, for various reasons, on account of the unstable nature of the foundation on which they would rest, the undermining action of the river currents and the violence of the storm waves; but that, even if these were constructed and maintained, the bar would advance so much more rapidly than before, that the jetties would need to be extended 600 feet every year to keep pace with this accelerated advance. Captain Eads contended that the river is a transporter of solid matter to the sea; that the amount transported depends upon its velocity modified by the depth of the water; that this principle determines the channel and the bars; that, if the banks of the pass were extended in parallel lines as they are by nature, the result would be an increased velocity, and this increased velocity would enable the river to pick up the particles of which the bar is composed, and carry them far out to sea, where under the influence of the Gulf currents they would be swept away; that as the crest of the bar was two and a quarter miles from the land's end, the crest of the new bar when formed could not possibly be nearer than two and a quarter miles from the end of the jetties, and that probably under the new conditions the formation of another bar would not take place for a century or two.

These views were so clearly and forcibly explained to members of Congress, that, in March, 1875, a bill was passed by which Captain Eads and his associates were authorized to construct and maintain jetties and auxiliary works for deepening the bar at the mouth of South Pass between the pass and

the Gulf of Mexico. It was the earnest wish of Captain Eads,—a wish which he urged in vain to the last hour of the session of Congress,—to improve the bar at the mouth of South-west Pass, because the greater depth and width of that pass afforded an entirely unobstructed outlet for the commerce of the valley, and one able to meet its increasing necessities. The width of the channel here through the jetties would have been 1,500 feet, while that of the South Pass is but 700 feet.

Immediately after the passage of the act, preparations were made for beginning the works. A contract was entered into with Colonel James Andrews, of Alleghany, Pa., the successful builder of the foundations of the St. Louis bridge. He arrived at the mouth of South Pass about the middle of June, 1875, bringing with him the necessary plant and force, and began work in earnest. By his indomitable will and untiring energy Colonel Andrews has proved himself equal to the task of carrying through to complete success this great and difficult undertaking.

Let me describe the surroundings here, as they appeared at the time of our arrival. Climb with me seventy-five feet to the top of the light-house: there is no other elevation or building within ten miles; you cast your eye over not exactly a landscape or a waterscape but an amphibio-scape of water, mud, reeds and alligators,—not an elevation as far as the eye or glass can reach that one could not easily leap over, except a solitary mud-lump lying off to the westward; an unbroken horizon of sky and water on every side. Fourteen and a half miles to the east lies the low green bank of Pass à l'Outre; as many miles to the west is the dim horizon line of the South-west Pass. A light-house stands at the mouth of each of these passes, and ten miles away to the north-west is barely distinguishable another, which marks the head of the passes. Half-way up the South Pass we see Bayou Grande diverging and flowing to the westward, carrying off about twenty-seven per cent. of its waters; while everywhere from the north-east to the south-west the rolling waters of the Gulf of Mexico stretch to the horizon. This beautiful ship-canal, South Pass, though small when compared with the other outlets, is large enough to meet any present or future need.

The jetties, let it be understood, are intended simply as a nucleus around and upon which Nature can build her banks, and so, some of the work, since it was to be solid-

ified by the processes of nature, has been of a comparatively imperfect character. A glance at the sketch giving a "bird's-eye view of the jetties" will show their general position in reference to the shore lines. Several objects were sought in their location:

1st. To lay them out in such a direction that they should be both parallel with the river currents, and, where they project into the Gulf, at right angles to the currents that sweep along the shore.

2d. To place them as far apart as was possible consistently with the necessary concentration of the volume of water, and at the same time to remove the jetties themselves from the undermining action of the river currents.

The jetty lines were marked out first on paper, and then at times with considerable difficulty on the bar. It will be seen that there were no landmarks near the line of the jetties from which measurements could be taken to locate the guide-piling. Here and there, perhaps a mile or more apart, were temporary stations or tripods marking triangulated points, which had been established during the preceding winter by the United States Coast Survey. From these, by careful calculations and instrumental work, the jetty lines were laid out in an easy curve, extending from land's end on the east to a point two and a quarter miles out in the Gulf.

The piling which marked the jetty lines was driven in various depths of water from four to thirty feet, and the foundation, which it had been prophesied would prove so unstable, was found to be so solid that a hammer weighing 3,000 pounds and falling nineteen feet could not with eighty blows force the pile more than seventeen feet into the bottom.

The jetties are constructed principally of willows. These trees grow in great abundance about twenty-five miles up the river, and vary in size from one to two and a half inches at the butt, and from fifteen to thirty feet in length. They are, however, not as pliable and easily twisted and tied as the osier willow, used on similar works in Europe. A peculiar construction was adopted by which these willows could be used most economically and at the same time suit the existing conditions, expecting that, in whatever manner they might be put into the water, they would soon fill with sediment. It was not necessary to make as firm and compact a

construction as would have been required if the whole jetty had been thrown out on some stormy coast into the clear salt water of the ocean. The construction most closely resembling that employed here was that used at the mouth of the Maas in Holland. There they constructed "zink-stukken," or mattresses of willow fascines, or bundles of willows compactly tied together. These fascines were laid close together and then others placed over them at right angles and all intermediate spaces filled with willows packed in closely. The several courses of fascines were then tied together tightly with cords or ropes, and the raft thus built was floated out to its place and sunk with gravel and stone.

The plan adopted by Captain Eads is much more simple in construction and is more economical. As this is the most important part of the construction of the jetties we will describe it in detail.

Along the bank of the pass near the land's end were built inclined ways at right angles to the shore line and extending back from the river bank about fifty feet. On these ways the mattresses were to be made. The inclines are so constructed that while the ends of the timbers are under water at the river they are about six feet above the level of the water at the other, or shore, end. These timbers are spaced about six feet apart, and are parallel with each other; a ribbon is spiked lengthwise on top of each one, the upper edge of which is rounded off; underneath the timbers are nailed inch boards, so that the men in working on the ways will not fall through. The ways are now ready for the mattress, which is built in the following manner:

The strips for the frames of the mattresses are piled up just above the ends of the ways. These strips are two and one-half by six inches and from twenty-five to forty-five feet long; the mattresses being usually one hundred feet long, the strips are cut to make that length when joined. They are placed on trucks and wheeled to that part of the ways where the mattress is to be built. After being lifted upon the ways the joints are fastened by a lap of the same material about six feet long, which is spiked to the strips. If the mattress is to be forty feet wide, nine strips are prepared. Holes are now bored through these strips one and one-eighth inches in diameter and spaced five feet apart. Hickory pins, whose ends have been turned to fit the holes tightly, are driven into them and oak wedges

driven into the lower ends of the pins, with twenty-penny nails to keep the pins steady. The strips, with the pins standing upright, are moved down the ways and spaced four feet and six inches apart. If the mattress is to be two feet thick,—the usual size,—the pins are cut thirty inches long, except the outer row on either side which is thirty-two inches. A part of the mattress-gang now climb upon the willow-barge and pass the willows down to other workmen standing on the frame, who place them carefully side by side on the strips across the frame. After a course about six inches thick is placed, another is laid lengthwise with the frame, then another at right angles to the last, and so on till the willows stand above the tops of the pins. In placing the willows the brushy tops are laid so as to project three or four feet outside the frame. The men then bore holes in other strips about forty feet long, place them across the mattress and insert the pins into the holes—pressing down the cross strips with levers. Wedges and nails are driven into the ends of the pins and the mattress is ready for launching. The mattress is easily pulled off the ways by a steam tug which tows it to its place along the jetty piling. A barge loaded with rock is then placed alongside the floating mattress and the stone distributed evenly over it until it sinks to the bottom. The foundation mattress is usually from forty to fifty feet wide, according to the depth of the water. The courses placed above it become narrower and narrower until they reach the surface of the water, where the average width is twenty-five feet. The last mattress is either built in place on the jetty at low tide, or built on the ways and pulled into place at high tide by a steam pile-driver, or built on tilting ways which rest on a barge from which the mattress is launched upon the jetty. When the mattresses are sunk at flood river, all the interstices fill very quickly with sediment which serves not only to hold it more securely in place but makes it much more impervious to water.

When the jetties were nearly constructed it was decided to build temporary spurs or wing dams at right angles to the jetties, extending into the channel about 150 feet. These wing dams narrowed the channel from 1,000 feet to about 700 feet. The objects in constructing these wing dams were: first, to locate the deep water channel midway between the jetties; second, to hasten the channel development; third, to

induce a deposit of sediment and an incipient bank formation along the channel side of the jetties. These wing dams were spaced about 600 feet apart. They were built by driving a row of piles out from the jetty line and resting the mattress against them, placing it on its edge.

In tracing the channel development, it may be stated that every obstruction placed in the river, every pile, mattress and rock, has made its influence felt somewhere in the excavation of the channel. From the very first mattress that was placed, an effect could be observed, and for the last two years, since the jetties were comparatively finished, there has been a constant channel development which can be shown quite forcibly by the following statement: In May, 1875, the distance between twelve feet depth inside the bar and twelve feet outside was 4,300 feet; in February, 1876, it was extinguished. In reference to the fifteen feet depth, the distance was 5,900 feet in May, 1875, and nothing in April, 1876. In May, 1875, it was 9,600 feet between the twenty feet curves, and nothing in August, 1876. In May, 1875, it was 11,700 feet between the twenty-six feet curves, and on March 27, 1879, it was nothing. In 1875, the whole length between the thirty feet curves from the land's end to the Gulf was two and a quarter miles or more exactly 12,000 feet in 1875, and on the completion of the work, July 9th, 1879, there was a channel thirty feet deep with a minimum width of forty-five feet from deep water in the pass to deep water in the Gulf. This channel at average tide exceeds in depth that of the ports of New York and Boston at high tide. Its navigability is incomparably better, being straight and wide. It is 700 feet in width at the surface of the water, and 200 feet wide at the bottom—at its narrowest point. Thirty and a half feet is the least depth of the channel, and this occurs at only one or two points. Elsewhere the channel varies in depth from thirty-one feet to seventy-five feet.

To form this channel through the bar has required the removal of about 5,500,000 cubic yards of material, which has been washed out by the current into the Gulf, whence a large part of it has then been driven back by the waves into the space behind the jetties and banked up against them. On the sea side of the east jetty the land has been extended out about a mile and is now thickly covered with reeds and grass. On the sea side of the west jetty several million cubic yards of material have been de-

posited, raising the whole area between the jetty and west shore nearly to the height of average flood tide. On the sea side of the jetties, nearly two miles from the old land's end, a new shore line has formed, composed of a hard, compact reef, and this is a secure and permanent protection to the jetties lying landward of it.

Before describing further the jetties and their effects, let us give our attention for a time to some of the auxiliary works.

The true theory of deepening the mouth of the river having once been found and nature's law understood, all the rest was comparatively simple. Success then depended more upon energy, persistence and money on the part of the contractor than skill on the part of the engineer. With the exception of fighting against storms and buffeting the waves, the construction of the jetties has encountered no great difficulties, but at the head of the passes was presented a problem in hydraulic engineering which was abstruse and difficult to understand, and was to be worked out on a larger scale and greater quantities than any ever before presented to the practical engineer. The engineering question from the first was not how to get the water *out* of, but how to get it *into* the pass, and while getting it in, to deepen the shoal that stretched across its inlet, from fifteen feet to twenty-six feet.

A glance at the sketch of the head of the passes will show any one at all familiar with such subjects, or any intelligent reader, that in order to produce a greater depth through the shoal at the head of South Pass, by inducing a greater volume to flow into it, would be very much like trying to make water run up hill.

Let it be impressed upon the mind that the bed of the river and of the passes is composed of alluvial deposits. They are what is left finally of the clays, gravel and quartz, that have lodged themselves in the beds and along the banks near the sources of the innumerable tributaries of the river. The particles of sedimentary matter that reach us have been ground to an almost infinitesimal size by the currents and eddies of the great river in its journey of thousands of miles. This material is almost as easily moved as the waters of the river itself.

The first work constructed extended from the east shore of the pass up stream to the point marked "Cluster" on the sketch. It is built of solid mattress work, and was expected to accomplish the whole result required; but instead of acting as a deflect-

ing dyke to draw into South Pass a portion of the waters of Pass à l'Outre, into whose currents it extended about 600 feet, it performed the office of a submerged dam and induced such a deposit in front of it on the South Pass side that the depth of the deposit kept pace with the height of the dyke.

At times it seemed as though the current would break through this dyke in spite of all opposing influences; it would work itself

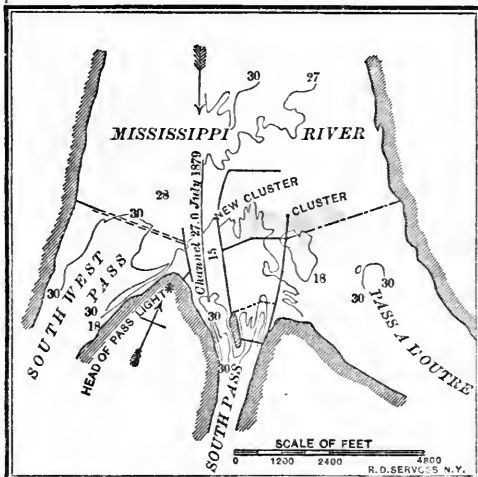

HEAD OF PASSES WITH CONTOUR LINES OF MAY, 1875, AND LOCATION OF DYKES. (THE FIGURES REFER TO THE DEPTHS OF THAT DATE.)

down into the recent deposit in deep holes and bays; but the very next day perhaps, examination would show that the depositing action had overcome all the resistance of the opposing current.

We found out too late that we must work on the same plan as that by which we were obtaining such success at the jetties. Nature taught us by practical experience and repeated failures that volumes must have contraction rather than expansion to attain scouring power. This law having become understood, the works hereafter were constructed on entirely different principles, which were briefly these: that in order to obtain scouring power sufficient to remove this extraordinary obstruction, half a mile long and ten feet deep, we must give the current greater velocity; to obtain this velocity, the volume of water remaining the same, we must give it a greater slope or fall, or in other words it must run down a steeper incline. To obtain this slope, we must raise the surface level of the water above the shoal and lower the surface below it. It may be well to state that with the river at half flood the fall per mile from Quarantine

to the head of the passes, a distance of 37 miles, is only about three-eighths of an inch to the mile. At the same stage of the river, the fall in South Pass from below the shoal to the mouth of the pass at Port Eads is about one and one-eighth inches per mile.

The works now to be described and constructed on the principles just mentioned produced a fall of five and a half inches per mile over the three-fourths of a mile covered by this shoal, which, by a curious coincidence, was the same fall per mile which was found at the same time to exist through the jetties at the mouth of the pass.

Starting as a base from the original dyke already described, a dam of tilted mattresses, like those used in the construction of the wing-dams, was thrown out across the new-forming shoal to the western inlet channel. Another dam was thrown out about 350 feet from the west shore near the light-house. Connecting with the ends of these dams two parallel dykes were constructed about 800 feet apart. The dyke on the east was really the working dyke, but was extended at that time only to the point marked "New Cluster." This dyke and the dam with which it was connected raised a head of water as soon as the river rose. The result was the extraordinary fall which has been spoken of and a consequent scour, producing a depth of about forty feet through the shoal all the way from New Cluster to the deep water of the pass; but with this gratifying result came another not so encouraging. It was found that the head of water raised above these works produced not only the necessary fall into South Pass, but produced a fall into the larger passes, and that a part of the volume rightfully belonging to South Pass flowed off on these side slopes into Pass à l'Outre and South-west Pass. The result was a deepening of these two larger passes and a loss in the volume of South Pass, accompanied with a shoaling in the whole length of it, including the jettied channel. To counteract these influences a sill or carpeting of mattresses was laid from the works at the head of South Pass entirely across South-west Pass and Pass à l'Outre, connecting with the western and eastern banks of the river. These sills were built of mattresses two feet thick, thirty feet wide, and seventy feet long. They were laid side by side on the bed of the passes, with their length in a line with the current, so that they formed a carpeting seventy feet wide. By these sills

and the works at the head of South Pass we were enabled to control the river.

Although the dykes mentioned produced a channel from New Cluster through the shoal, the deepening did not extend any further up stream. During the past winter and spring, this dyke has been extended 1,200 feet up the river, and a cross dam 1,600 feet long built from its terminus eastward into the waters of Pass à l'Outre. Two more courses of mattresses have been laid over the western half of the mattress sill laid across South-west Pass and the dyke on the west side of the inlet channel has been extended up stream, and the dyke on the east side of the inlet channel extended down stream to connect with the island. A substantial dam had previously been constructed between the island and the east bank of the pass. The channel on the west side of the island is enlarging very rapidly by caving in and washing away the western bank. Its capacity will soon be sufficiently large to carry with ease the whole volume of the waters of the pass.

The channel through the shoal is twenty-seven feet deep, and the twenty-six feet channel is 165 feet wide, as ascertained from the survey on July 10th, 1879, made by Captain M. R. Brown, the government inspecting officer. This channel has been obtained by the extension of the works previously mentioned, assisted by dredging.

The contract with the government, as we have said, makes it necessary to obtain certain depths and widths before payment is made. It has often been found that there was a much greater depth of channel than that required, but with a width somewhat less. Again, it has happened that in some portion of the channel a very wide section has been found whose depth was a few inches less than that required. To meet such cases, and also to assist the current in scouring away points that obstinately resisted its action, Captain Eads constructed a powerful hydraulic dredge-boat, capable of working in almost any weather and in any depth of water required here. The pump is on the Andrews patent. It is the largest ever constructed in the United States, and is similar to the two "Caratact" pumps shown at the Philadelphia Exhibition, but is twice the capacity of both. The fan is six feet long and three feet wide, and the suction pipe which supplies it with the sand and water is thirty inches in diameter, with the end resting on the bottom and furnished with a scraper, which drags over

the bed of the river. The material is pumped into iron tanks, built in the boat, whose total capacity is about 500 cubic yards. The boat is constructed of iron throughout, and is supplied with all the appliances necessary to do the work. Its capacity under favorable circumstances is about 3,000 cubic yards of solid earth per day of ten hours.

The channel at the jetties has also been assisted somewhat in its development by an Osgood dipper dredge, but the whole amount removed by dredging is not more than one per cent. of the volume removed by the river itself.

The only other auxiliary work worthy of mention here is the mattress dam across Grand Bayou. This bayou was about 300 feet wide and thirty feet deep. Since the construction of the dam it is about four feet deep and the volume formerly passing through it to the Gulf now passes through the jetties.

As the permanency of the jetties and other works is a matter of great importance, a description of the natural and artificial means for securing this end may be of interest. At the head of the passes, some of the works, though of a provisional and temporary character, have been rendered thoroughly permanent by the extensive deposits of sediment that have formed around them and in some cases entirely covered them. The first mile of both jetties has been rendered permanent by the same means, and all that will be required above the new shore line, previously spoken of, will be the incorporation of gravel into the top mattresses to prevent leakage through them at high tide. Beyond this shore line, a most substantial and permanent work has been applied. This consists of massive blocks of concrete composed of sand, gravel, broken stone and Portland cement. These ingredients are mixed together thoroughly by a cubical concrete steam mixer, about six feet square, constructed on an improved plan after a design by Captain Eads. Each block is formed in a mold *in situ*. The charge of concrete, about two cubic yards, on being discharged from the mixer into an iron dumping car drawn by a small locomotive, is taken on a railroad track, which is laid upon a trestle about eight feet above the jetty, to a point immediately over the mold and dumped into it. Seventy-five cubic yards have been laid in one day at a point 1,000 feet from the mixer. The foundation is prepared by incorporating

gravel and broken stone into the mattresses. The blocks are protected from undermining by abundant slopes of riprap. These concrete blocks increase in size as they approach the end of the jetties. There they weigh about sixty-five tons each. The substantial character of the foundation on which they rest may be understood from the fact that although they have been in place four months they have not settled more than two inches. Where these blocks are constructed, the water was fifteen feet deep before the jetties were commenced. There are at least eight courses of mattresses under them. These mattresses, although built with a vertical wall against the prevailing winds, have stood intact against the tremendous wave force that has been brought to bear upon them. They are built in a locality where, if anywhere, the foundation on which they rest would be unstable.

At distances of every fifty feet near the outer end of the work are built spur cribs about twenty feet square filled with rock on which a concrete block is built connected with the main blocks of the jetty. Flanking the work at the extreme sea end are massive cribs of palmetto logs filled with riprap and surmounted with larger rock.

We may confidently expect from the experience that the jetties have passed through during their unprotected state while under construction, that with the substantial protection recently applied to them they will stand undisturbed against the most severe storms of the Gulf.

The materials used in all works or on hand at Port Eads are in round numbers as follows: Willows, 592,000 cubic yards; stone, 100,000 cubic yards; gravel, 10,000 cubic yards; concrete in place, 4,300 cubic yards or 9,000 tons; piling and lumber, 12,000,000 feet, board-measure.

The difficulty and expense incurred in procuring these materials, will be appreciated by giving the places from which they were obtained and their distances from Port Eads. The willows were brought from an extensive swamp or miniature delta called the Jump, about twenty-five miles above the jetties, and from the banks of the river as far up as the mouth of Red River, a distance of 315 miles. The greater portion of the stone came from Rose Clare, Indiana, on the Ohio River, 1,320 miles distant; much of the remainder from Vicksburg, Mississippi, and some from all parts of the world, brought here as ballast in vessels, and discharged either at Port Eads

or New Orleans. The gravel came from an island in the Mississippi River, 260 miles above; the sand for the concrete, from the shores of the Mississippi Sound, 110 miles away; Saylor's Portland cement, from Pennsylvania, *via* New York, by steamers and sailing vessels; the lumber, from Pearl River, Mississippi, 130 miles; the palmetto logs for the crib work from Appalachicola, Florida, 300 miles to the eastward; and

also found that it was not necessary to build the jetties as far into the Gulf as was originally planned, and they now stand as completed 300 feet nearer the land's end than the farthest guide-piling was driven in 1875.

It is not too broad an assertion to make, that every theory advanced by Captain Eads, every statement made by him in reference to the channel which he should secure, and in reference to the advance of

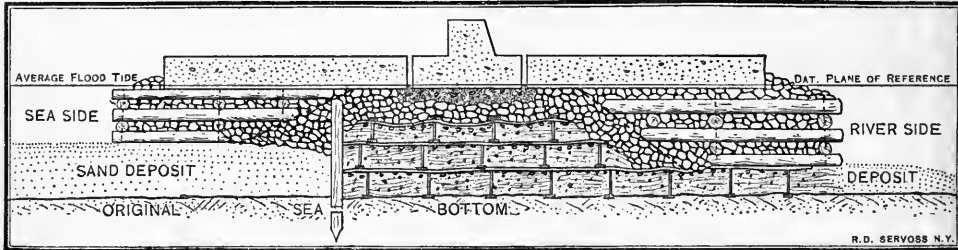

SECTION OF JETTY, 11,100 FEET FROM LAND'S END, SHOWING MATTRESSES, SPUR CRIBS, AND CONCRETE BLOCKS. SCALE, TEN FEET TO ONE INCH.

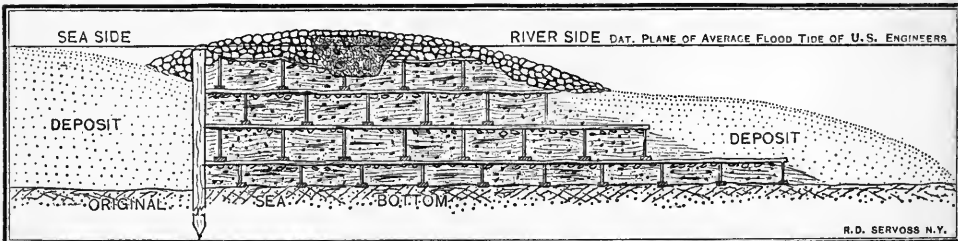

SECTION OF JETTY, 7,500 FEET SEAWARD FROM LAND'S END. SCALE, TEN FEET TO ONE INCH.

finally, 11,000 cubic yards of dirt ballast was received in vessels from foreign ports, and placed on the banks at Port Eads for raising them above the highest tides.

Another very important subject to be considered is the probability of the jetties being extended on account of the advance of the bar seaward. Surveys during the four years of jetty construction, both by the Jetty Engineer Corps and by Captain Brown show clearly and decisively that there has been *no* advance of the bar, and that there is consequently no probability of any need for an extension of the jetties in the immediate future. These surveys reveal another fact, that there is no bar forming in the Gulf beyond the jetties. They show still further that, instead of the Gulf filling up in advance of the jetties, it has deepened; instead of the bar advancing, it has receded landward; and that there is more water at the end of the jetties and immediately in front of them, than there was in June, 1875, when the work was commenced. We have

the bar in front of his works, has been fully verified by actual results. These results are all that the most sanguine anticipated, but the objects for which the jetties were built are of far greater importance, for they affect the welfare of millions and are destined finally to exert an influence on the whole country.

These objects will be realized in a development, and in an increasing prosperity of the Mississippi valley. The work which has been accomplished will stretch its relieving and assisting hand to the remotest frontiersman, who, knowing that an open river-mouth will make it profitable for him to raise cereals, will cut down new forests and cultivate a larger farm. It will induce greater production everywhere in the Mississippi valley, and with it an increasing immigration.

Already the grain export of the valley is turning into this, its natural channel. The following table, compiled from official sources, will show the tendency to increas-

ing shipments of cereals by way of the jetties:

SHIPMENTS OF CORN IN BULK:

1874-'75	199,997	bushels.
1875-'76	1,257,089	"
1876-'77	2,490,300	"
1877-'78	5,249,457	"

WHEAT IN BULK:

1875-'76	38,301	bushels.
1876-'77	172,218	"
1877-'78	843,058	"

It is estimated that the jetties, by partially improving the channel at the mouth of the river, saved the country \$1,600,000.00 during the year ending Sept. 1st, 1878, by a reduction in freights on cotton alone.

It must be borne in mind that the channel through the jetties is only just obtained. The changes that will take place in the production and shipments of cereals and cotton will come slowly; but in a few years we will see one of the greatest revolutions of the century in agriculture and commerce.

Other and more immediate benefits to commerce resulting from an improved channel can be seen from the following table, which compares the detentions at the bars of Pass à l'Outre and South-west Pass with the detentions at the mouth of South Pass.

	Number of vessels crossing the bar.		Number of vessels detained.	Number hours detention.	Maximum draft during the year.
Pass à l'Outre and South-west Pass.	1874	2633	55	2302	19' 6"
	1875	2177	76	2516	19' 6"
South Pass	1878	1869	18	499	22' 11"
	1879 to July 1	1113	0	0	23' 6"

It must be remembered that at the former places the channel was improved by the government dredge boats; at the latter the jetties were under construction and the channel was but partially developed.

The extraordinary results of the jetties and the far-reaching commercial and agricultural results flowing from them have been obtained by four years and a half of most severe exertion and struggle, in a contest not so much with the river currents and wave action as with moral forces. Here was a contract involving the immediate outlay of two or three millions of private capital before any return could be reasonably expected from government payments. The project was declared chimerical by the experts of the government itself in published pamphlets, in written statements, in verbal testimony before Congressional committees and in newspaper articles. These ideas were repeated in daily journals and in scientific and engineering periodicals. Not only before the act was passed by Congress, but subsequent to its passage and during the construction of the work these opposing views were kept persistently before the public, hampering, delaying, jeopardizing the enterprise and making it necessary in order to carry it on to borrow money at ruinous rates of interest. Still the mind that conceived this great project and fought it through Congress and into the good opinion of the American people, was willing to admit no such word as fail. He was never discouraged, never faltered or wavered, never lost for an instant a sublime faith in the correctness of his theories and in the justice and complete success of his cause. To him is the Mississippi valley and the whole country indebted for the greatest internal improvement that the world has ever seen.

EXTRACTS FROM THE JOURNAL OF HENRY J. RAYMOND.

EDITED BY HIS SON.

A PRIVATE record kept by one who was in public life for nearly thirty years is necessarily filled with comments, conversations, thoughts, and criticisms noted down at odd moments and never intended in any manner for publication. And although such off-hand comments or memoranda possess peculiar attractions on account

of their freedom from restraint, and their revelations of the inner life of the writer, yet respect for the feelings of persons who may still be living, or the danger of placing one who is without the power of defense in the position of an accuser, renders the task of selection from such materials peculiarly delicate and difficult. Pages most

precious to those whom the writer has left behind—as they recall the traits and the peculiarities so prized in life—may after all have but little interest to a public to whom the author was but a name or a thought. I have therefore attempted in preparing the few pages of extracts from my father's journal, which it seemed to me might prove of general interest, to avoid such allusions or selections as from their nature would be likely to lead to controversy.

My father never kept a diary in the usual sense of the word, or even a series of connected memoranda, but, as he had time and opportunity would note such incidents as seemed worthy of remembrance on the unused leaves of an old "Index Rerum," which had evidently been a college friend and companion. Nor can I better introduce this first paper—which pertains to the period of his connection with the "New York Courier and Enquirer," and of his first active political efforts—than by giving in its entirety the preface he himself wrote, before commencing the original. He says :

"It often happens that I hear remarks, observe peculiarities or notice incidents in regard to distinguished persons which it would be pleasant afterward to recall to mind. I shall hereafter note such, so far as limited leisure will permit, in the form of miscellaneous memoranda; and as the record is intended simply for my own amusement or for that of intimate friends, I shall not fear to incur any charge of egotism or of trifling by inserting things which good taste or propriety would exclude from anything intended to come at any time before the public. The only justification needed for the undertaking, as well as the most appropriate motto for it, is found in the hackneyed phrase from Virgil :

"Hæc olim meminisse juvabit."

My father's anticipations as to the fragmentary and desultory character of the memoranda were fully justified. Editors, forty years ago, were generally news-gatherers and reporters as well as writers; and these various duties left him very little leisure during the day or night. His political life also began about this time, and he never believed in half work in anything. The same feeling which, in his college life, led him to read all the works of a Greek or Latin author, when the college curriculum called perhaps for but a few selections, was carried into his daily life. It was but a little less than three years after the date of the first entry in his journal that he founded the "New York Times," and there are many things in it which show that the subject of a metropolitan daily newspaper,

with the highest standard for every department, was even at that time a matter of thought with him. With so much time necessarily occupied by his daily official duties, and while he was maturing and perfecting the scheme which in 1851 resulted in his establishment of the "Times," no wonder that there were many wide gaps between the different entries, during which the connection was entirely lost.

"January, 1848.—During this month, I made my first visit to Washington. While there, Mr. Webster made an argument before the Supreme Court in a case involving the merits of the rebellion in Rhode Island in 1842. I reported that argument, and on the 30th (Friday) I called at Mr. Webster's house to read to him the report of it, which I had prepared. The more I see of him, the more profoundly does he impress me with his greatness,—a greatness which is intrinsic and truly majestic, which derives no addition from external circumstances, and which is quite as impressive to the valet as to one who sees the subject of it only on holiday occasions.

"Mr. Webster expressed great satisfaction at my report, and seemed especially anxious to have the argument clearly set forth. As I read over to him the successive points, to every one which seemed peculiarly clear, he would exclaim, 'Good,' 'That's true,' 'That's it,' etc., etc., apparently forgetting that the argument was his own, and applauding the performance of some other person. After the report was finished, I expressed my great admiration of its iron logic, and remarked that I thought it very timely, and well calculated to correct notions which are doing great mischief at the present time. He said he trusted it would be of service in that respect, and regretted the small attention which public men, legislators, etc., usually devote to discussions of these fundamental principles of government. I ventured to express a hope that he would give the world a philosophical history of Washington's administration, upon which I had been told he had been engaged, because I thought it would be desirable for his own fame, and would, moreover, set up a landmark for future ages.

"Mr. Webster said he had contemplated such a work; he had marked out its plan; resolved to make three volumes of it; divided it into chapters; written a portion, and made a very copious collection of materials for the whole work. He stated quite in detail the outline of his plan—saying that he desired neither to make it a mere narration like Hume, nor a mere biography like Rapin, but to combine the two and make the whole as vivid and graphic as possible. The persons whom Washington grouped around him in council seemed to command his special admiration, and he expressed a great desire to paint the scenes presented by their councils with more warmth than belonged (in his opinion) to his temperament.

"At a very early period of his life, he said, he began to think the exposition of the Constitution his special field, his 'mission,' and the little that he knew, he added, was in that direction. He had of necessity studied the life and character of Washington very closely, and it was a character which would bear studying. We often hear, especially at the present time, of men who, though not wise themselves, have the tact to choose wise counselors. Many speak so of Washington. But the distinc-

tion was not just. All history, he said, shows that no weak prince will choose wise counselors; he does not want to be surrounded by men superior to himself; he would feel dwarfed by their presence. Mr. Tyler had been unjustly dealt with in this respect. For a time he was very willing to trust public affairs with his secretary, scarcely interfering with them at all. The whole Ashburton negotiation—the little affair with Lord Ashburton's as Mr. Webster styled it—he confided entirely to Mr. Webster; and so with the Rhode Island troubles. Mr. Webster was surprised at this, but he said Mr. Tyler promised to be a much better President than the public supposed. Until Mr. Clay's 'acrimonious violence' drove him into the ranks of the opposition, Mr. Tyler conducted affairs with dignity and ability. But he had not been in office a month when Mr. Clay insisted upon an answer to the question whether Mr. Tyler intended to run for a second term? And he pressed it so pertinaciously and with so much violence, that Mr. Tyler said one day, jocularly, 'Mr. Clay, I have been so much annoyed by this that I believe I shall send for Mr. Southard (President of the Senate) and resign at once.' This convinced Mr. Clay that Mr. Tyler would stand again, and from that time he denounced him and drove him into the opposition, thus blasting all the fruits of the Whig victory of 1840. He would have had the same difficulty with General Harrison, had he lived.

"I spoke of Mr. Clay's pressing for a renomination now, and expressed surprise. Mr. Webster said J. Q. Adams some years ago remarked that 'Mr. Clay would be a candidate so long as he should receive a nomination from a majority of the people in the town of Lexington'—and he believed it would prove true. The mere pleasure of being talked of as a candidate, he said, was a positive gratification which became necessary to many men, and grew stronger with their age. After all, said he, what will Mr. Clay leave for future ages? His speeches contain nothing of permanent value—all relating to temporary topics, and never discussing fundamental principles. He is not an instructed statesman,—he knows nothing of the matters in that paper we have talked about; and for what, said he, will he be remembered?—For his brilliant, effective, popular eloquence, I suggested. Yes, said he, but how much has that availed Patrick Henry? It is ephemeral, traditional, of little value to any one. Mr. Clay, he thought, had always kept the Whig party subservient to his personal ambition, and seemed still disposed to do so. Mr. Webster talked in this strain for some time, and with great freedom and earnestness.

"He asked if I had heard Attorney-General Clifford in reply to his Rhode Island argument. I told him only in part. He said that Mr. Clifford remarked that Mr. Webster's premises were undeniable, and he could not see any flaw in his logic; but there must be some fallacy in it, because it led to conclusions which he could not admit! This, Mr. Webster said, was like Jefferson, who told him once that in very early life he resolved to have nothing to say to John Marshall, for he would always get him to admit certain positions (which he could not question) and then he would lead him to conclusions which he would not believe, and which he could not avoid! This, he said, was characteristic of Jefferson, who had no reasoning faculty, but who knew exactly how to touch the popular feeling, and was entirely unscrupulous in exercising that skill.

"Mr. Webster talked very freely for an hour, and said he intended to speak in the Senate on the war

question, and desired that I should report it. He said he should not speak upon the question until the close of the debate. I said he seemed not to share the fears which other Senators had expressed, that if they could not speak soon the subject would be exhausted! You know, said Mr. Webster, we farmers have a fashion of going over a field for the gleanings after the harvest. Yes, said I, and some could find more there than others could at first. Mr. Webster said he did not wish to speak if the rumors of a treaty then current should prove to be well founded. He had no idea of having it thus upset. I asked him if he did not look forward with apprehension to the issue of the war, and the absorption of all Mexico. He said he did,—that the future was entirely overcast, and it was very difficult to see any way of safety. But, he added, he was not disposed to sit down in perfect despair as Mr. Calhoun had done, and say that he could see no future for his country. Even if annexation of all Mexico should take place, and a dissolution of our Union should be the result, still, said he, we of the North are on the safe side. We have the wealth, the numbers, the commerce, the enterprise. All the best elements of national power are on our side; we are the strongest portion, and in the event of dissolution we must still constitute the great nation of the continent. We had, therefore, less to fear from this crisis than other portions of the country. I said that few public men were willing to look the matter thus boldly in the face. He said he never alluded to it publicly, but these were the views he took of it in his private reflections upon the subject.

"In course of the conversation concerning the notions prevalent in regard to popular liberty, I said that the time seemed distant when men in this country should be governed by cool reason and judgment instead of prejudice and passion. He said yes,—that the prospect was discouraging, because events were constantly occurring to turn the tide even when it seemed to be setting well. Under Mr. Adams things went on pretty well. Then came Jacksonism, which threw the whole country into the boiling caldron of passion and excitement. Then under Mr. Van Buren the tone of public feeling, especially the spirit that prevailed at Washington, greatly improved, and continued to do so until Mr. Clay, by his acrimonious course toward Mr. Tyler, again threw everything into confusion, and now we were in a condition certainly unpromising enough.

"My interview with Mr. Webster lasted an hour or more, and he talked very freely,—with great dignity and deliberation, yet as socially and easily as if with an old friend. There was about him nothing of the hauteur usually ascribed to him; yet he never forgot, though he did not seem to remember, his character and fame. One of the young ladies of his household rapped at the door to tell him that Mr. C— was awaiting him in the parlor. 'Entertain him,' said he, smiling and bowing, slowly, and as impressively as ever he spoke in the Senate. I apologized for having trespassed so unwarrantably upon his time. He said he was very glad to see me, invited me to call at pleasure, etc., etc.

"During my stay in Washington I had several long conversations with Mr. Butler King, M. C. of Georgia, concerning public affairs. He said the South was under a very great apprehension that Mexico would become part of the Union, and that this would crush the South at once. He said Whigs at the South would be governed by this in the coming canvass, and would throw everything else

to the winds. He thought Taylor the only man whose popularity could stem the torrent of radicalism now sweeping over the country and so peculiarly dangerous to the South.

"February 10.—Active preparations are making for the Taylor meeting on the 22d in this city. I had been requested to write the address and resolutions, and had done so. Calling at Mr. J. P. Hall's office to hand them to him, I found Messrs. Maxwell, Blatchford, Draper, and Hall there. The question was asked whether Mr. Webster approved of the Taylor meeting. Mr. Blatchford said he did not,—that he felt offended because he had not been consulted in regard to it by some of his friends who had signed the call,—that he thought his own name ought still to be kept up as a candidate, etc., etc. Mr. B. then read a letter he had just received from Mr. Webster, sustaining these views. It was marked "private and confidential," and began by expressing surprise that he had not been consulted in regard to it. As to the policy of the meeting, he thought it bad; it would strengthen Mr. Clay's chance of the nomination, especially if no other Whig candidate but Taylor was kept before the people, because, he said, there were hundreds of thousands of religious and sober-minded men who would not go for Taylor, and who would be driven to Clay. This was the upshot of his letter. Mr. Blatchford said Mr. Webster believed he could be elected President, and none of his friends dared undeceive him. It had been attempted by one or two, but he had turned upon them like a chafed lion; and it was now understood that no one could talk to him in that way without forfeiting his friendship.

"Mr. Blatchford said further that Mr. Clay would be deserted by his professed friends, when the proper time came; that Mr. Seward, whom he characterized as the wisest and most cunning politician of the day, would come out strong for Taylor when it could be done with best effect, in spite of all present appearances to the contrary. Mr. Hall said the ground would fall from under Mr. Clay's feet before long, and he wouldn't know "what hurt him." Professor Davies told me to-day that he had a letter from his brother-in-law, E. D. Mansfield of Cincinnati, who said that Mr. Greeley had written a letter to some one in that city, which he had seen and could get, saying explicitly that the Clay movement here was merely a *feint*, intended to cover the bringing out of Corwin or Seward as the candidate of *the North*, and to fight the next canvass on that ground.

"The Taylor meeting for the 22d, I may add, was started by Col. Webb, who wrote the call and submitted it to Hall (J. P.), Grinnell, Maxwell, J. A. King, Charles King, and one or two others, at a caucus held at the "Courier and Enquirer" office the day before it was first published. I urged that it should be made a strong Whig call; Hall wanted it a no-party call, and Maxwell was afraid it would be too much Whig. The form adopted (Whig) was finally chosen. A very active canvass was at once set on foot to obtain signers. It was rather up-hill work, but had still a good degree of success."

"February 15.—Mr. L. Davis told me to-day that Mr. Clay had written to some one here (he had seen the letter), saying that he should come to Philadelphia next week; that all was going on well in Washington, in spite of slight counter currents, which were always to be looked for, and that he had heard, but did not believe, that Mr. Van Buren had indicated an intention to go for General Taylor—all which goes to show that Mr. Clay personally is taking an active part in the canvass.

"In the evening the Taylor Committee of Arrangements met at the Astor House, and adopted the address which I had written. Slight efforts were made to take out the Whig National Convention passage, and Colonel Webb objected to the anti-war (!) spirit of some sentences; but it was adopted without any material alteration.

"Colonel Webb wrote a paragraph (in the "Courier and Enquirer" of 16th) disavowing my paragraph of to-day, saying we had 'no sympathy with independent Taylorism.'

"Stetson, who was at the caucus, told me some amusing anecdotes of Webster. He (S.) once expostulated with Mr. Webster for not being more gracious to strangers and talking to them freely, as Clay and Van Buren do, urging that it would increase his popularity, etc. 'I can't make a pump-handle of my arm to be President,' said Webster.

"At the Baltimore Convention in '44, after Clay had been nominated, and after Webster had made his speech responding to it, J. M. Botts (of Va.) met Mr. Webster, and began to congratulate him on his *return* to the Whig party, saying no one esteemed him more highly, or would be more rejoiced to see him President, etc., etc., than himself. Mr. Webster looked him in the face, raised his shaggy eyebrows, smiled (as a thundercloud might be supposed to smile), and said, without offering his hand, 'You don't say so!' and turned on his heel.

"The independent Taylor meeting is to be held this evening at Military Hall. Being requested to write the address, I did so, in order to give the proceeding a Whig bias."

[The address was presented and adopted.]

"January 2, 1850.—Nearly two years have elapsed since I have made an entry in these memoranda. I shall resume it now, however, probably only to discontinue it again before many days. Before going on with the record, let me recur to some of the incidents of the intervening period:

"Under 'January, 1848,' I have mentioned that Mr. Webster expressed a wish that I should report a speech he intended to make on the Mexican question. I told him I would gladly do so, if he would give me notice of the time. A few weeks after, I received a letter from him, saying he was going to speak the second day after its date, and would be glad to see me there. I started the next morning. Mr. Van Buren, Mr. James Wadsworth and myself were in the same car. When we reached Newark, the train ran into the drawbridge, which was left open. Great damage was done; two were killed, and the whole train was saved from destruction only by the accidental giving way of part of the wood-work to which the coupling chains were fastened. Mr. Van Buren was reading a newspaper when the accident occurred. The sudden stop startled us all. He looked up, rose, went to the window, saw demolished cars, floating baggage, half a dozen persons struggling in the water, and one or two being hauled out manifestly dead, and very quietly re-seated himself and resumed his paper. Query. Was this coolness indifference, courage, or heartlessness? The accident turned me back, and I telegraphed to Mr. Webster that, in consequence, it would be impossible for me to reach Washington by the day he had fixed, but if he desired I would be there the day after. I received in reply the following:

"H. J. RAYMOND.

"Come.

"D. W.,"

and went accordingly. I called upon him early in the morning—found him arranging his books and not very well. He made his speech to a densely crowded Senate, giving me Mr. Corwin's seat (Mr. C. being absent) to report at. I wrote about half the speech out that night, and started with him and Mrs. Webster next day for New York. I had a good deal of conversation with him on the way,—but so long a time has elapsed that I have forgotten most of it. I remember asking him whether in his judgment the Supreme Court of the United States had fulfilled the original design of the Constitution, and whether it was as upright and important as at first. He said he thought not, and proceeded to give me a history of the court and sketches of the men who had sat in it, with the manner in which and the influences by which they were appointed. This I cannot recall, but it was one of the most admirable sketches in all respects ever made.

"We took breakfast at Baltimore and went on to Philadelphia, where we all stopped at Hartwell's. After dinner I completed my report, and in the evening read it over to Mr. Webster in the presence of Mrs. Webster and Senator Greene, of Rhode Island. All of them expressed frequent admiration of the accuracy and spirit of the report, and when I had finished Mrs. Webster said—'You needn't give yourself any trouble, Daniel, about your speeches as long as Mr. Raymond reports them.' The effect of hearing her call him *Daniel* was curious. Next day we came on to New York, and he went to Boston.

"My last record is 'February 15th.' Soon after that time, viz.: February 22, the great Taylor meeting came off in an immense tent at Niblo's. It rained horribly, and was a doleful time. A week before there had been an *enormous* Clay meeting at Castle Garden. The contrast gave great delight to the enemies of General Taylor. Things went on, however; the Philadelphia Convention was held, General Taylor was nominated, and after a hard struggle was *electd*. * * * * *

"I was soon after asked to become a candidate for the Assembly. I did not suppose Colonel Webb would get any appointment, and thought it would be of decided service to spend a session in the Legislature.

[In explanation of this paragraph I may interpolate a few words here to say that my father was at this time an editorial writer and managing editor of the "Courier and Enquirer," of which Colonel Webb was proprietor and editor-in-chief. Soon after General Taylor's election Colonel Webb had applied for a foreign mission, but had been

refused on grounds which it was not deemed possible to change].

"I therefore accepted the nomination, and was elected. Colonel Webb soon received the appointment of *chargé* to Vienna, and accepted it—declaring that he did it only on the supposition that it would be made a full mission. * * * * * General Cass some time before had voluntarily written to Colonel Webb saying he need be under no apprehension about his confirmation, as he should have his vote, and that of any man whom he could influence. *I saw and read the letter*. And yet in spite of this pledge General Cass very early in the session introduced a bill to suspend all diplomatic intercourse with Austria!"

"*January 1st, 1851.*—And now I find myself at Albany as member of Assembly. The house has 64 Democrats, 63 Whigs, and one Whig whose seat is disputed and who therefore waived his right to take part in organizing the House. The result was that the Democrats elected every officer. The Governor's message was read to-day."

"*January 3d.*—Nothing done to-day except drawing for choice of seats. I find that it is a common practice for members who are fortunate, to select a good seat—not because they wish to occupy it, but to *sell* it. Mr. Pruyn to-day paid \$20 for a seat. Leaders of parties strive to secure seats from which they can readily command the speaker's attention, and thus secure the floor. Mr. Burroughs, who has rather offensively set himself up as a leader of the Democratic party, has been trying to buy an eligible seat to-day, but several Whigs made up a purse to outbid him! This is party tactics. After adjournment wrote an editorial on slavery; got from the Comptroller a synopsis of his report,—read the Governor's message and Comptroller's reports for 1847, 1848, and 1849,—read Whittier's graphic sketches of Ellwood, James Naylor, and William Leggett, and went to bed at half-past twelve. Leggett was certainly a brave and gifted man. His abolitionism was the result of a noble impulse, but I cannot join with Whittier in wishing all young men to be like Leggett. The world needs *discretion* as much as *zeal*, and although the latter generally usurps all the honors and glories of heroism, the former does a great deal the most toward carrying on the daily affairs of society and states. If everybody were discreet and nobody zealous, things would certainly go on much better than if everybody were zealous and nobody discreet. This form of statement, however, misleads—as it makes *extremes* the standard of comparison and judgment, which is never safe. Zeal tempered and guided by discretion, or discretion warmed and energized by zeal, is the true temperament for safe and successful conduct.

THE AGRICULTURAL DISTRESS IN GREAT BRITAIN.

In traveling through England the past summer, I soon came to the conclusion that English agricultural industries are now in a worse condition than they have been at any time during the past quarter of a century, and, what is more alarming to the farmers of England, who employ their capital and

time in cultivating the soil for profit, that there is little or no hope of any improvement in the future. Each successive year since 1874 has brought more discouraging results than the preceding one, for the healthful growth and maturity of the staples. The seasons of 1875, 1876, 1877,

and 1878 were discouraging enough, but the present year has surpassed all those named in the quantity of rain that has fallen, making the land heavy, cold, and soggy, too wet even to produce an average crop of hay. From the first of January until the first of August, there have not been more than four clear days. It has been one continuous storm, with more inches of rainfall than ever before has been recorded in the same length of time.

As a natural consequence of such wet weather, the crops of cereals are late in coming to maturity, and will fall far short of an average yield, even on the best farms in England. In ordinary seasons the wheat and barley crops in England are cut and stacked by the middle of August, and the oat crop a week later. But this year, owing to the causes named, there was not a spear of wheat or barley that would be ripe enough to cut before the 25th of August, and besides the chances of getting fine weather while the grain was in the shock were exceedingly meager, leaving, at best, a large bulk of the wheat crop of 1879 second and third grades, to sell for correspondingly low prices. In former years a short crop of wheat in England made but a trifling difference in the net results to the farmers, for just as soon as it was announced that the crop would fall below the average, the market prices went up, bringing in to the grower about the same amount for a short as for a full crop. This is no longer the case. It is now positively known that there will be an unusually large deficiency this year, one that will exceed a hundred millions of bushels of wheat. Yet the prices in the Liverpool and London Corn Exchanges are quoted at £2 9s. a quarter (that is, eight bushels), or about what good wheat would bring in former years with a full crop. English grain merchants, as well as intelligent farmers, assert that this is solely owing to American competition and American wheat. Indeed the English farmer traces all his present and prospective troubles to this source alone. On the whole, there is no doubt that the farmers in England, Scotland, and Ireland are in an unenviable position, without much hope of relief, even by the thorough investigation of the royal commission recently appointed by Parliament to examine the present agricultural distress.

No commission, no matter from what source it may spring or with what power it may be clothed, can alter the conditions or disadvantages under which English farmers

have to labor, nor is it possible for them to compete in growing wheat with American farmers. It is a well-known fact that English farmers, except in rare instances, do not own the farm land they cultivate, and, under the existing state of things, they are far better off than if they were sole proprietors and held a fee simple. The value of farming land in England is not based on what it is capable of producing; it is chiefly valuable because it gives its owner and his family a social position extremely difficult to attain by any other means. The English landlord, while generous and liberal in many ways with his tenants, is very arbitrary in his articles of agreement, and (looking at these from an American farmer's stand-point) the English farmer is handicapped from the start for the purpose of protecting the owner's interests. The conditions embodied in these leases are about as follows:

1st. The farmer must have \$100 for every acre he hires, as a working capital.

2d. He must keep one-third of the whole number of acres in permanent pasture and meadow during occupancy.

3d. He must not deviate from the four-course rotation of crops specified in the lease.

The annual rent for good farming land in England is from eight to nine dollars an acre, and to this may be added poor rates and road taxes, making the actual rent in round numbers not less than ten dollars an acre, which has to be paid punctually, rain or shine. In former times, before the days of American competition, the frugal English farmer expected to make, and did make from six to eight per cent. on his capital, invested either in grain-growing or in raising beef; while there has been no time for the last quarter of a century when the land owner has realized more than two per cent. from his investment; this is owing to the exorbitant prices paid for farming land on account of its social valuation, and there are plenty of buyers at these high rates. Those not familiar with the existing condition of things in England naturally suppose that relief would soon follow if farmers owned the land they till; but the truth is, it would make matters worse instead of better, and they now prefer to lease the farms from year to year, instead of for the long terms formerly in vogue among the most intelligent English farmers. A long lease means better security to the landlord, for it binds the farmer to remain, and carry out the conditions of his contract, no matter whether

he is making or losing money. In computing the outlay of the English farmer, the rent of land, labor, manures, use of implements, etc., etc., the best English agricultural authorities firmly assert that the farmers of England, under the most favorable auspices, cannot grow wheat with any profit for less than \$1.50 a bushel, and the margin of profit at this figure is comparatively small.

The series of bad seasons, which have to a large extent brought about the present distressed condition of English agricultural industries, are not the only obstacles in the way of the present generation of English farmers competing, even on equal footing, with their American cousins. The annual rent paid by the English farmer would purchase much more fertile wheat soil in the wheat belt of the West. Moreover, most of the labor with us being done by improved machinery, the cost of production is much less, enabling the grower to land sound wheat on the docks of Liverpool at \$1.12 a bushel, at a handsome profit both to the farmer and the merchant. Again, on account of the heavy rents for the land, and the many other incidental expenses, beef raised on English farms cannot be sold at any profit to the farmer for less than sixteen cents a pound. On the contrary, the American cattle-raiser of the South-west pays a trifle for his ranch, and is under no extra expense for wintering his stock, so that beef raised in this way can be put in the English markets for ten or twelve cents a pound, with a liberal profit to the owner and the shipper. Unless the signs are greatly at fault, where there is one person now engaged in raising beef for foreign shipments, there will be ten times as many five years hence. American cheese has already forced hundreds of English farmers from cheese-making to raising milk for the London and other large markets, and the business is now so crowded that the price of fresh milk is a third less than it was before American cheese became so popular among English consumers.

In traveling among well-to-do English farmers the past summer, I was surprised to note the lack of economy and the amount of land that is wasted on hundreds of farms by those wide ditches and straggling and unkept hedges which are used as boundaries of small and irregular-shaped fields, the latter, owing to the shape, calling for much extra labor in cultivating them. Another very noticeable feature is the large, heavy and cumbersome character of the farm im-

plements. American manufacturers of farm tools shape them in such a way as to do the work with the least physical labor. The English manufacturer, on the other hand, has a pride in making everything substantial, heavy and solid, without any regard to the weight or strength needed. Why, there is more wood and iron in an English farm-cart than would make two American carts, and yet with their superb roads they load theirs no heavier than we do ours. An English manure fork is of the same size and pattern it was half a century ago—a square, rough tine shouldered near the point—calling for the greatest amount of force in loading or unloading. The American fork is a round polished tine, tapering gradually from the point to the base, and calling for the least power. The weight of an English plow is at least three times that of ours and its length about twice, and yet it takes neither wider nor deeper furrow-slices than our best plows. In fact, one pair of horses attached to one of our best pattern plows will do from a third to a half more work in the same number of hours than an English farmer with his long, unwieldy pattern that is out of all proportion, both in length and weight, to the work it is intended for. The same is true of the English harrows, cultivators and all of the implements I found in common use for turning or cultivating the soil. The ordinary wooden hand-rake is a clumsy, heavy thing, having from a third to a half more wood than is actually necessary. In many instances, in going through England, I have counted eight and ten hands gathering hay into windrows with these hand-rakes, an operation very seldom, if ever, seen now in the United States. In many of the agricultural districts which I visited, farmers cultivating from forty to a hundred acres of land still continue to cut their grain crops with the reaping hook and cradle. The English cradle has a scythe blade of ordinary size and length, with two short wooden fingers. The man cutting with this cradle throws the cut grain around against the uncut standing grain. Another man follows the cradler, equipped with a piece of stick about three feet in length with an iron hook on the end of it, and gathers the cut grain into sheafs and places them on the stubble before the next swath can be cut. The American, or what is commonly called the “Yankee,” cradle has a wide scythe-blade similar in size and length to the English, but instead of two short fingers it has four long ones, and the operator cuts the grain, which falls

on the fingers and which is thrown into a sheaf on the stubble entirely out of the way of the next cradler who follows, leaving the cut grain ready to be bound, one man with us doing the work of two in England. In talking on the subject with an intelligent farmer in Essex County, England, I had difficulty in convincing him that the long fingers of the "Yankee" cradle would not or could not get tangled up in the straw, nor could I induce him to send and get an American cradle, although he was complaining of the high price of farm labor when compared with the low price of farm produce.

In rambling through the agricultural districts I had many favorable opportunities of making personal inspection of the tools and farm machinery of some of the best equipped farms, and in every instance they all had the same character—that is, the tools were out of proportion for the work to be done, or the weight or strength needed. The English farmers in many respects remind one of the implements and farm machinery they use. They are, as a rule, solid, substantial and easy-going. They have taken the world and its affairs in an easy, matter-of-fact way.

English farmers take little interest in matters outside of their own business. They are extremely conservative and are perfectly satisfied with their home form of government, no matter whether they are rich or poor. Up to five years ago they made money enough to pay their obligations and live comfortably, and they had enough left over to lay some aside for future use. It is natural, therefore, with labor plenty and cheap, that they should plod along in the footsteps of their grandfathers. They do not devote much of their time to agricultural literature (the agricultural journals are poorly supported), or bother their heads over scientific farming. They grow the same crops in precisely the same way their fathers did before them, calculating to get about the same yield and profits. The character and results of the wonderful agricultural experiments of John B. Lawes, LL. D., of Rothamsted, are more widely read and better understood in the United States than they are among the English farmers. They have for the last five years been losing money, and for some time they could not realize that such a condition of things could ever come to pass. But the combined force of bad weather and active American competition has all but driven many into a state of bank-

ruptcy and bewilderment. They are thoroughly frightened, and they have very substantial reasons for being so. Their present condition is bad enough, and their prospects gloomy.

As long ago as 1862, Horace Greeley told me that the time was near at hand when American farmers, with the aid of improved modern labor-saving machinery, could and would place a bushel of American wheat in the English markets at a lower figure than it could be raised by the present methods followed in England, and, moreover, with a fair profit to the grower. The realization of this fact now stares our conservative cousins in the face. The introduction of American cheese, beef, and pork has been accomplished in such quantities and at such prices as to make these branches of industry equally unprofitable. The rot in the potato has been so general for the past five years that there has been less reliance on that crop, and less surface planted this year than usual, and there is no doubt that large quantities of American potatoes will find their way into the English markets during this fall and winter. As yet there has been no outside competition in barley; and it is the only crop that has not been affected, and many farmers intend to sow next year twice the surface heretofore allotted to it.

It is safe and certainly within bounds to say that American farmers, with their labor-saving machinery, can raise produce at a third less expense than English farmers can with their clumsy methods. It is also evident that within the next five years large numbers of English farmers will be forced to emigrate to Australia and the United States. The fact is that agriculture in England, once a prominent and vital interest, has now fallen to a third or fourth place. Even the London "Times," once the champion of this industry, now hardly recognizes its existence, and will devote more space in its columns in one week to a boat-race between Oxford and Cambridge students than it will in two years to agricultural interests. There are a few enthusiasts among the farmers who religiously believe that the royal commission will recommend to Parliament a duty on American grain. But any one who is familiar with the sentiment of the masses of the people on this point knows there is not the remotest chance of such action, for the simple reason that where there is one farmer interested, there are twelve persons who want and must have cheap bread and cheese.

CONFIDENCE.

BY HENRY JAMES, JR.,

Author of "The American," "The Europeans," "Daisy Miller," Etc.

CHAPTER VII.

IT was not till Longueville reached Paris, on his return from the distant East, that the rumor I have just mentioned acquired an appreciable consistency. Here, indeed, it took the shape of authentic information. Among a number of delayed letters which had been awaiting him at his banker's he found a communication from Gordon Wright. During the previous year or two his correspondence with this trusted—and trusting—friend had not been frequent, and Bernard had received little direct news of him. Three or four short letters had overtaken him in his wanderings—letters as cordial, to all appearance, if not as voluminous, as the punctual missives of an earlier time. Bernard made a point of satisfying himself that they were as cordial; he weighed them in the scales of impartial suspicion. It seemed to him on the whole that there was no relaxation of Gordon's epistolary tone. If he wrote less often than he used to do, that was a thing that very commonly happened as men grew older. The closest intimacies, moreover, had phases and seasons, intermissions and revivals, and even if his friend had, in fact, averted his countenance from him, this was simply the accomplishment of a periodical revolution which would bring them in due order face to face again. Bernard made a point, himself, of writing tolerably often and writing always in the friendliest tone. He made it a matter of conscience—he liked to feel that he was treating Gordon generously, and not demanding an eye for an eye. The letter he found in Paris was so short that I may give it entire.

"My dear Bernard (it ran), I must write to you before I write to any one else, though unfortunately you are so far away that you can't be the first to congratulate me. Try and not be the last, however. I am going to be married—as soon as possible. You know the young lady, so you can appreciate the situation. Do you remember little Blanche Evers, whom we used to see three years ago at Baden-Baden? Of course you remember her, for I know you used often to talk with her. You will be rather surprised, perhaps, at my having se-

lected her as the partner of a life-time; but we manage these matters according to our lights. I am very much in love with her, and I hold that an excellent reason. I have been ready any time this year or two to fall in love with some simple, trusting, child-like nature. I find this in perfection in this charming young girl. I find her so natural and fresh. I remember telling you once that I didn't wish to be fascinated—that I wanted to estimate scientifically the woman I should marry. I have altogether got over that, and I don't know how I ever came to talk such nonsense. I am fascinated now, and I assure you I like it! The best of it is that I find it doesn't in the least prevent my estimating Blanche. I judge her very fairly—I see just what she is. She's simple—that's what I want; she's tender—that's what I long for. You will remember how pretty she is; I needn't remind you of that. She was much younger then, and she has greatly developed and improved in these two or three years. But she will always be young and innocent—I don't want her to improve too much. She came back to America with her mother the winter after we met her at Baden, but I never saw her again till three months ago. Then I saw her with new eyes, and I wondered I could have been so blind. But I wasn't ready for her till then, and what makes me so happy now is to know that I have come to my present way of feeling by experience. That gives me confidence—you see I am a reasoner still. But I am under the charm, for all my reason. We are to be married in a month—try and come back to the wedding. Blanche sends you a message, which I will give you verbatim. 'Tell him I am not such a silly little chatterbox as I used to be at Baden-Baden. I am a great deal wiser; I am almost as clever as Angela Vivian.' She has an idea you thought Miss Vivian very clever—but it is not true that she is equally so. I am very happy; come home and see."

Bernard went home, but he was not able to reach the United States in time for Gordon's wedding, which took place at midsummer. Bernard, arriving late in the autumn, found his friend a married man of some

months' standing, and was able to judge, according to his invitation, whether he appeared happy. The first effect of the letter I have just quoted had been an immense surprise; the second had been a series of reflections which were quite the negative of surprise, and these operations of Bernard's mind had finally merged themselves in a simple sentiment of jollity. He was delighted that Gordon should be married; he felt jovial about it; he was almost indifferent to the question of whom he had chosen. Certainly, at first the choice of Blanche Evers seemed highly incongruous; it was difficult to imagine a young woman less shaped to minister to Gordon's strenuous needs than the light-hearted and empty-headed little flirt whose inconsequent prattle had remained for Bernard one of the least importunate memories of a charming time. Blanche Evers was a pretty little goose—the prettiest of little geese, perhaps, and doubtless the most amiable; but she was not a companion for a peculiarly serious man, who would like his wife to share his view of human responsibilities. What a singular selection—what a queer infatuation! Bernard had no sooner committed himself to this line of criticism than he stopped short, with the sudden consciousness of error carried almost to the point of *naïveté*. He exclaimed that Blanche Evers was exactly the sort of girl that men of Gordon Wright's stamp always ended by falling in love with, and that poor Gordon knew very much better what he was about in this case than he had done in trying to solve the deep problem of a comfortable life with Angela Vivian. This was what your strong, solid, sensible fellows always came to; they paid, in this particular, a larger tribute to pure fancy than the people who were supposed habitually to cultivate that muse. Blanche Evers was what the French call an article of fantasy, and Gordon had taken a pleasure in finding her deliciously useless. He cultivated utility in other ways, and it pleased and flattered him to feel that he could afford, morally speaking, to have a childish, kittenish wife. He had within himself a fund of common sense to draw upon, so that to espouse a paragon of wisdom would be but to carry water to the fountain. He could easily make up for the deficiencies of a wife who was a little silly, and if she charmed and amused him, he could treat himself to the luxury of these sensations for themselves. He was not in the least afraid of being ruined by it, and if Blanche's birdlike chat-

ter and turns of the head had made a fool of him, he knew it perfectly well, and simply took his stand upon his rights. Every man has a right to a little flower-bed, and life is not all mere kitchen-gardening. Bernard rapidly extemporized this rough explanation of the surprise his friend had offered him, and he found it all-sufficient for his immediate needs. He wrote Blanche a charming note, to which she replied with a great deal of spirit and grace. Her little letter was very prettily turned, and Bernard, reading it over two or three times, said to himself that, to do her justice, she might very well have polished her intellect a little during these two or three years. As she was older, she could hardly help being wiser. It even occurred to Bernard that she might have profited by the sort of experience that is known as the discipline of suffering. What had become of Captain Lovelock and that tender passion which was apparently none the less genuine for having been expressed in the slang of a humorous period? Had they been permanently separated by judicious guardians, and had she been obliged to obliterate his image from her lightly beating little heart? Bernard had felt sure at Baden that, beneath her contemptuous airs and that impertinent consciousness of the difficulties of conquest by which a pretty American girl attests her allegiance to a civilization in which young women occupy the highest place—he had felt sure that Blanche had a high appreciation of her handsome Englishman, and that if Lovelock should continue to relish her charms, he might count upon the advantages of reciprocity. But it occurred to Bernard that Captain Lovelock had perhaps been faithless; that, at least, the discourtesy of chance and the inhumanity of an elder brother might have kept him an eternal prisoner at the *Hôtel de Hollande* (where, for all Bernard knew to the contrary, he had been obliged to work out his destiny in the arduous character of a polyglot waiter); so that the poor young girl, casting backward glances along the path of Mrs. Vivian's retreat, and failing to detect the onward rush of a rescuing cavalier, had perforce believed herself forsaken, and had been obliged to summon philosophy to her aid. It was very possible that her philosophic studies had taught her the art of reflection; and that, as she would have said herself, she was tremendously toned down. Once, at Baden, when Gordon Wright happened to take upon himself to remark that little Miss

Evers was bored by her English gallant, Bernard had ventured to observe, *in petto*, that Gordon knew nothing about it. But all this was of no consequence now, and Bernard steered further and further away from the liability to detect fallacies in his friend. Gordon had engaged himself to marry, and our critical hero had not a grain of fault to find with this resolution. It was a capital thing; it was just what he wanted; it would do him a world of good. Bernard rejoiced with him sincerely, and regretted extremely that a series of solemn engagements to pay visits in England should prevent his being present at the nuptials.

They were well over, as I have said, when he reached New York. The honeymoon had waned, and the business of married life had begun. Bernard, at the end, had sailed from England rather abruptly. A friend who had a remarkably good cabin on one of the steamers was obliged by a sudden detention to give it up, and on his offering it to Longueville, the latter availed himself gratefully of this opportunity of being a little less discomposed than usual by the Atlantic billows. He therefore embarked at two days' notice, a fortnight earlier than he had intended and than he had written to Gordon to expect him. Gordon, of course, had written that he was to seek no hospitality but that which Blanche was now prepared—they had a charming house—so graciously to dispense; but Bernard, nevertheless, leaving the ship early in the morning, had betaken himself to an hotel. He wished not to anticipate his welcome, and he determined to report himself to Gordon first and to come back with his luggage later in the day. After purifying himself of his sea-stains, he left his hotel and walked up the Fifth Avenue with all a newly landed voyager's enjoyment of terrestrial locomotion. It was a charming autumn day; there was a golden haze in the air; he supposed it was the Indian summer. The broad sidewalk of the Fifth Avenue was scattered over with dry leaves—crimson and orange and amber. He tossed them with his stick as he passed; they rustled and murmured with the motion, and it reminded him of the way he used to kick them in front of him over these same pavements in his riotous infancy. It was a pleasure, after many wanderings, to find himself in his native land again, and Bernard Longueville, as he went, paid his compliments to his mother-city. The brightness and gayety of the place seemed a

greeting to a returning son, and he felt a throb of affection for the freshest, the youngest, the easiest and most good-humored of great capitals. On presenting himself at Gordon's door, Bernard was told that the master of the house was not at home; he went in, however, to see the mistress. She was in her drawing-room, alone; she had on her bonnet, as if she had been going out. She gave him a joyous, demonstrative little welcome; she was evidently very glad to see him. Bernard had thought it possible she had "improved," and she was certainly prettier than ever. He instantly perceived that she was still a chatterbox; it remained to be seen whether the quality of her discourse were finer.

"Well, Mr. Longueville," she exclaimed, "where in the world did you drop from, and how long did it take you to cross the Atlantic? Three days, eh? It couldn't have taken you many more, for it was only the other day that Gordon told me you were not to sail till the 20th. You changed your mind, eh? I didn't know you ever changed your mind. Gordon never changes his. That's not a reason, eh, because you are not a bit like Gordon. Well, I never thought you were, except that you are a man. Now what are you laughing at? What should you like me call you? You *are* a man, I suppose; you are not a god. That's what you would like me to call you, I have no doubt. I must keep that for Gordon? I shall certainly keep it a good while. I know a good deal more about gentlemen than I did when I last saw you, and I assure you I don't think they are a bit god-like. I suppose that's why you always drop down from the sky—you think it's more divine. I remember that's the way you arrived at Baden when we were there together; the first thing we knew, you were standing in the midst of us. Do you remember that evening when you presented yourself? You came up and touched Gordon on the shoulder, and he gave a little jump. He will give another little jump when he sees you to-day. He gives a great many little jumps; I keep him skipping about! I remember perfectly the way we were sitting that evening at Baden, and the way you looked at me when you came up. I saw you before Gordon—I see a good many things before Gordon. What did you look at me that way for? I always meant to ask you. I was dying to know."

"For the simplest reason in the world," said Bernard. "Because you were so pretty."

"Ah no, it wasn't that! I know all about that look. It was something else—as if you knew something about me. I don't know what you can have known. There was very little to know about me, except that I was intensely silly. Really, I was awfully silly that summer at Baden—you wouldn't believe how silly I was. But I don't see how you could have known that—before you had spoken to me. It came out in my conversation—it came out awfully. My mother was a good deal disappointed in Mrs. Vivian's influence; she had expected so much from it. But it was not poor Mrs. Vivian's fault, it was some one's else. Have you ever seen the Vivians again? They are always in Europe; they have gone to live in Paris. That evening when you came up and spoke to Gordon, I never thought that three years afterward I should be married to him, and I don't suppose you did either. Is that what you meant by looking at me? Perhaps you can tell the future. I wish you would tell *my* future!"

"Oh, I can tell that easily," said Bernard.

"What will happen to me?"

"Nothing particular; it will be a little dull—the perfect happiness of a charming woman married to the best fellow in the world."

"Ah, what a horrid future!" cried Blanche, with a little petulant cry. "I want to be happy, but I certainly don't want to be dull. If you say that again you will make me repent of having married the best fellow in the world. I mean to be happy, but I certainly sha'n't be dull if I can help it."

"I was wrong to say that," said Bernard, "because, after all, my dear young lady, there must be an excitement in having so kind a husband as you have got. Gordon's devotion is quite capable of taking a new form—of inventing a new kindness—every day in the year."

Blanche looked at him an instant, with less than her usual consciousness of her momentary pose.

"My husband is very kind," she said gently.

She had hardly spoken the words when Gordon came in. He stopped a moment on seeing Bernard, glanced at his wife, blushed, flushed, and with a loud, frank exclamation of pleasure, grasped his friend by both hands. It was so long since he had seen Bernard that he seemed a good deal moved; he stood there smiling, clasping his

hands, looking him in the eyes, unable for some moments to speak. Bernard, on his side, was greatly pleased; it was delightful to him to look into Gordon's honest face again and to return his manly grasp. And he looked well—he looked happy; to see that was more delightful yet. During these few instants, while they exchanged a silent pledge of renewed friendship, Bernard's elastic perception embraced several things besides the consciousness of his own pleasure. He saw that Gordon looked well and happy, but that he looked older, too, and more serious, more marked by life. He looked as if something had happened to him—as, in fact, something had. Bernard saw a latent spark in his friend's eye that seemed to question his own for an impression of Blanche—to question it eagerly, and yet to deprecate judgment. He saw, too—with the fact made more vivid by Gordon's standing there beside her in his manly sincerity, and throwing it into contrast—that Blanche was the same little posturing coquette of a Blanche whom, at Baden, he would have treated it as a broad joke that Gordon Wright should dream of marrying. He saw, in a word, that it was what it had first struck him as being—an incongruous union. All this was a good deal for Bernard to see in the course of half a minute, especially through the rather opaque medium of a feeling of irreflective joy; and his impressions at this moment have a value only in so far as they were destined to be confirmed by larger opportunity.

"You have come a little sooner than we expected," said Gordon; "but you are all the more welcome."

"It was rather a risk," Blanche observed. "One should be notified when one wishes to make a good impression."

"Ah, my dear lady," said Bernard, "you made your impression—as far as I am concerned—a long time ago, and I doubt whether it would have gained anything to-day by your having prepared an effect."

They were standing before the fire-place, on the great hearth-rug, and Blanche, while she listened to this speech, was feeling, with uplifted arm, for a curl that had strayed from her chignon.

"She prepares her effects very quickly," said Gordon, laughing gently. "They follow each other very fast!"

Blanche kept her hand behind her head, which was bent slightly forward; her bare arm emerged from her hanging sleeve, and, with her eyes glancing upward from under

her lowered brows, she smiled at her two spectators. Her husband laid his hand on Bernard's arm.

"Isn't she pretty?" he cried; and he spoke with a sort of tender delight in being sure at least of this point.

"Tremendously pretty!" said Bernard. "I told her so half an hour before you came in."

"Ah, it was time I should arrive!" Gordon exclaimed.

Blanche was manifestly not in the least discomposed by this frank discussion of her charms, for the air of distinguished esteem adopted by both of her companions diminished the crudity of their remarks. But she gave a little pout of irritated modesty—it was more becoming than anything she had done yet—and declared that if they wished to talk her over, they were very welcome; but she should prefer their waiting till she got out of the room. So she left them, reminding Bernard that he was to send for his luggage and remain, and promising to give immediate orders for the preparation of his apartment. Bernard opened the door for her to pass out; she gave him a charming nod as he stood there, and he turned back to Gordon with the reflection of her smile in his face. Gordon was watching him; Gordon was dying to know what he thought of her. It was a curious mania of Gordon's, this wanting to know what one thought of the women he loved; but Bernard just now felt abundantly able to humor it. He was so pleased at seeing him tightly married.

"She's a delightful creature," Bernard said, with cordial vagueness, shaking hands with his friend again.

Gordon glanced at him a moment, and then, coloring a little, looked straight out of the window; whereupon Bernard remembered that these were just the terms with which, at Baden, after his companion's absence, he had attempted to qualify Angela Vivian. Gordon was conscious—he was conscious of the oddity of his situation.

"Of course it surprised you," he said, in a moment, still looking out of the window.

"What, my dear fellow?"

"My marriage."

"Well, you know," said Bernard, "everything surprises me. I am of a very conjectural habit of mind. All sorts of ideas come into my head, and yet when the simplest things happen I am always rather startled. I live in a reverie, and I am perpetually waked up by people doing things."

Gordon transferred his eyes from the win-

dow to Bernard's face—to his whole person.

"You are waked up? But you fall asleep again!"

"I fall asleep very easily," said Bernard.

Gordon looked at him from head to foot, smiling and shaking his head.

"You are not changed," he said. "You have traveled in unknown lands; you have had, I suppose, all sorts of adventures; but you are the same man I used to know."

"I am sorry for that!"

"You have the same way of representing—of misrepresenting, yourself."

"Well, if I am not changed," said Bernard, "I can ill afford to lose so valuable an art."

"Taking you altogether, I am glad you are the same," Gordon answered, simply; "but you must come into my part of the house."

Yes, he was conscious—he was very conscious; so Bernard reflected during the two or three first days of his visit to his friend. Gordon knew it must seem strange to so irreverent a critic that a man who had once aspired to the hand of so intelligent a girl—putting other things aside—as Angela Vivian should, as the Ghost in "Hamlet" says, have "declined upon" a young lady who, in force of understanding, was so very much Miss Vivian's inferior; and this knowledge kept him ill at his ease and gave him a certain pitiable awkwardness. Bernard's sense of the anomaly grew rapidly less acute; he made various observations which helped it to seem natural. Blanche was wonderfully pretty; she was very graceful, and innocent, and amusing. Since Gordon had determined to marry a little goose, he had chosen the animal with extreme discernment. It had quite the plumage of a swan, and it sailed along the stream of life with an extraordinary lightness of motion. He asked himself indeed at times whether Blanche were really so silly as she seemed; he doubted whether any woman could be so silly as Blanche seemed. He had a suspicion at times that, for ends of her own, she was playing a part—the suspicion arising from the fact that, as usually happens in such cases, she over-played it. Her empty chatter, her futility, her childish coquetry and frivolity—such light wares could hardly be the whole substance of any woman's being; there was something beneath them which Blanche was keeping out of sight. She had a scrap of a mind somewhere, and even a little fraction of a heart.

If one looked long enough one might catch a glimpse of these possessions. But why should she keep them out of sight, and what were the ends that she proposed to serve by this uncomfortable perversity? Bernard wondered whether she were fond of her husband, and he heard it intimated by several good people in New York who had had some observation of the courtship, that she had married him for his money. He was very sorry to find that this was taken for granted, and he determined, on the whole, not to believe it. He was disgusted with the idea of such a want of gratitude; for, if Gordon Wright had loved Miss Evers for herself, the young lady might certainly have discovered the intrinsic value of so disinterested a suitor. Her mother had the credit of having made the match; Gordon was known to be looking for a wife. Mrs. Evers had put her little feather-head of a daughter very much forward, and Gordon was as easily captivated as a child by the sound of a rattle. Blanche had an affection for him now, however; Bernard saw no reason to doubt that, and certainly she would have been a very flimsy creature indeed if she had not been touched by his inexhaustible kindness. She had every conceivable indulgence, and if she married him for his money, at least she had got what she wanted. She led the most agreeable life conceivable, and she ought to be in high good-humor. It was impossible to have a prettier house, a prettier carriage, more jewels and laces for the adornment of a plump little person. It was impossible to go to more parties, to give better dinners, to have fewer privations or annoyances. Bernard was so much struck with all this that, advancing rapidly in the intimacy of his gracious hostess, he ventured to call her attention to her blessings. She answered that she was perfectly aware of them, and there was no pretty speech she was not prepared to make about Gordon.

"I know what you want to say," she went on; "you want to say that he spoils me, and I don't see why you should hesitate. You generally say everything you want, and you needn't be afraid of me. He doesn't spoil me, simply because I am so bad I can't be spoiled; but that's of no consequence. I was spoiled ages ago; every one spoiled me—every one except Mrs. Vivian. I was always fond of having everything I want, and I generally managed to get it. I always had lovely clothes; mamma thought that was a kind of a duty. If it was a duty,

I don't suppose it counts as a part of the spoiling. But I was very much indulged, and I know I have everything now. Gordon is a perfect husband; I believe if I were to ask him for a present of his nose, he would cut it off and give it to me. I think I will ask him for a small piece of it some day; it will rather improve him to have an inch or two less. I don't say he's handsome; but he's just as good as he can be. Some people say that if you are very fond of a person you always think them handsome; but I don't agree with that at all. I am very fond of Gordon, and yet I am not blinded by affection, as regards his personal appearance. He's too light for my taste, and too red. And because you think people handsome, it doesn't follow that you are fond of them. I used to have a friend who was awfully handsome—the handsomest man I ever saw—and I was perfectly conscious of his defects. But I'm not conscious of Gordon's, and I don't believe he has got any. He's so intensely kind, it's quite pathetic. One would think he had done me an injury in marrying me, and that he wanted to make up for it. If he has done me an injury I haven't discovered it yet, and I don't believe I ever shall. I certainly sha'n't as long as he lets me order all the clothes I want. I have ordered five dresses this week, and I mean to order two more. When I told Gordon, what do you think he did? He simply kissed me. Well, if that's not expressive, I don't know what he could have done. He kisses me about seventeen times a day. I suppose it's very improper for a woman to tell any one how often her husband kisses her; but, as you happen to have seen him do it, I don't suppose you will be scandalized. I know you are not easily scandalized; I am not afraid of you. You are scandalized at my getting so many dresses? Well, I told you I was spoiled—I freely acknowledge it. That's why I was afraid to tell Gordon—because when I was married I had such a lot of things; I was supposed to have dresses enough to last for a year. But Gordon hadn't to pay for them, so there was no harm in my letting him feel that he has a wife. If he thinks I am extravagant, he can easily stop kissing me. You don't think it would be easy to stop? It's very well, then, for those that have never begun!"

Bernard had a good deal of conversation with Blanche, of which, as far as she was concerned, the foregoing remarks may serve as a specimen. Gordon was away from home during much of the day; he had a chemical

laboratory in which he was greatly interested, and which he took Bernard to see; it was fitted up with the latest contrivances for the pursuit of experimental science, and was the resort of needy young students, who enjoyed, at Gordon's expense, the opportunity for pushing their researches. The place did great honor to Gordon's liberality and to his ingenuity; but Blanche, who had also paid it a visit, could never speak of it without a pretty little shudder.

"Nothing would induce me to go there again," she declared, "and I consider myself very fortunate to have escaped from it with my life. It's filled with all sorts of horrible things, that fizzle up and go off, or that make you turn some dreadful color if you look at them. I expect to hear a great clap some day, and half an hour afterward to see Gordon brought home in several hundred small pieces, put up in half a dozen little bottles. I got a horrid little stain in the middle of my dress that one of the young men—the young *savants*—was so good as to drop there. Did you see the young *savants* who work under Gordon's orders? I thought they were too forlorn; there isn't one of them you would look at. If you can believe it, there wasn't one of them that looked at me; they took no more notice of me than if I had been the charwoman. They might have shown me some attention, at least, as the wife of the proprietor. What is it that Gordon's called—isn't there some other name? If you say 'proprietor,' it sounds as if he kept a hotel. I certainly don't want to pass for the wife of a hotel-keeper. What does he call himself? He must have some name. I hate telling people he's a chemist; it sounds just as if he kept a shop. That's what they call the druggists in England, and I formed the habit while I was there. It makes me feel as if he were some dreadful little man, with big green bottles in the window and 'night-bell' painted outside. He doesn't call himself anything? Well, that's exactly like Gordon! I wonder he consents to have a name at all. When I was telling some one about the young men who work under his orders,—the young *savants*,—he said I must not say that—I must not speak of their working 'under his orders.' I don't know what he would like me to say! Under his inspiration!"

During the hours of Gordon's absence, Bernard had frequent colloquies with his friend's wife, whose irresponsible prattle amused him, and in whom he tried to dis-

cover some faculty, some quality, which might be a positive guarantee of Gordon's future felicity. But often, of course, Gordon was an auditor as well; I say an auditor, because it seemed to Bernard that he had grown to be less of a talker than of yore. Doubtless, when a man finds himself united to a garrulous wife, he naturally learns to hold his tongue; but sometimes, at the close of one of Blanche's discursive monologues, on glancing at her husband just to see how he took it, and seeing him sit perfectly silent, with a fixed, inexpressive smile, Bernard said to himself that Gordon found the lesson of listening attended with some embarrassments. Gordon, as the years went by, was growing a little inscrutable; but this, too, in certain circumstances, was a usual tendency. The operations of the mind, with deepening experience, became more complex, and people were less apt to emit immature reflections at forty than they had been in their earlier days. Bernard felt a great kindness in these days for his old friend; he never yet had seemed to him such a good fellow, nor appealed so strongly to the benevolence of his disposition. Sometimes, of old, Gordon used to irritate him; but this danger appeared completely to have passed away. Bernard prolonged his visit; it gave him pleasure to be able to testify in this manner to his good will. Gordon was the kindest of hosts, and if in conversation, when his wife was present, he gave precedence to her superior powers, he had at other times a good deal of pleasant bachelor-talk with his guest. He seemed very happy; he had plenty of occupation and plenty of practical intentions. The season went on, and Bernard enjoyed his life. He enjoyed the keen and brilliant American winter, and he found it very pleasant to be treated as a distinguished stranger in his own land—a situation to which his long and repeated absences had relegated him. The hospitality of New York was profuse; the charm of its daughters extreme; the radiance of its skies superb. Bernard was the restless and professionless mortal that we know, wandering in life from one vague experiment to another, constantly gratified and never satisfied, to whom no imperious finality had as yet presented itself; and, nevertheless, for a time he contrived to limit his horizon to the passing hour, and to make a good many hours pass in the drawing-room of a demonstrative flirt.

For Mrs. Wright was a flirt; that had become tolerably obvious. Bernard had known

of old that Blanche Evers was one, and two or three months' observation of his friend's wife assured him that she did not judge a certain ethereal coquetry to be inconsistent with the conjugal character. Blanche flirted, in fact, more or less with all men, but her opportunity for playing her harmless batteries upon Bernard were of course exceptionally large. The poor fellow was perpetually under fire, and it was inevitable that he should reply with some precision of aim. It seemed to him all child's play, and it is certain that when his back was turned to his pretty hostess he never found himself thinking of her. He had not the least reason to suppose that she thought of him—excessive concentration of mind was the last vice of which he accused her. But before the winter was over, he discovered that Mrs. Gordon Wright was being talked about, and that his own name was, as the newspapers say, mentioned in connection with that of his friend's wife. The discovery greatly disgusted him. Bernard Longueville's chronicler must do him the justice to say that it failed to yield him an even transient thrill of pleasure. He thought it very improbable that this vulgar rumor had reached Gordon's ears; but he nevertheless—very naturally—instantly made up his mind to leave the house. He lost no time in saying to Gordon that he had suddenly determined to go to California, and that he was sure he must be glad to get rid of him. Gordon expressed no surprise and no regret. He simply laid his hand on his shoulder and said, very quietly, looking at him in the eyes:

"Very well; the pleasantest things must come to an end."

It was not till an hour afterward that Bernard said to himself that his friend's manner of receiving the announcement of his departure had been rather odd. He had neither said a word about his staying longer nor urged him to come back again, and there had been (it now seemed to Bernard) an audible undertone of relief in the single sentence with which he assented to his visitor's withdrawal. Could it be possible that poor Gordon was jealous of him, that he had heard this loathsome gossip, or that his own observation had given him an alarm? He had certainly never betrayed the smallest sense of injury; but it was to be remembered that even if he were uneasy, Gordon was quite capable, with his characteristic habit of weighing everything, his own honor included, in scrupulously adjusted

scales, of denying himself the luxury of active suspicion. He would never have let a half suspicion make a difference in his conduct, and he would not have dissimulated; he would simply have resisted belief. His hospitality had been without a flaw, and if he had really been wishing Bernard out of his house he had behaved with admirable self-control. Bernard, however, followed this train of thought a very short distance. It was odious to him to believe that he could have appeared to Gordon, however guiltlessly, to have invaded even in imagination the mystic line of the marital monopoly; not to say that, moreover, if one came to that, he really cared about as much for poor little Blanche as for the weathercock on the nearest steeple. He simply hurried his preparations for departure, and he told Blanche that he should have to bid her farewell on the following day. He had found her in the drawing-room, waiting for dinner. She was expecting company to dine, and Gordon had not yet come down.

She was sitting in the vague glow of the fire-light, in a wonderful pink dress, with two little pink feet crossed on the rug and pointed at the hearth. She received Bernard's announcement with small satisfaction, and expended a great deal of familiar ridicule on his project of a journey to California. Then, suddenly getting up and looking at him a moment:

"I know why you are going," she said.

"I am glad to hear my explanations have not been lost."

"Your explanations are all nonsense. You are going for another reason."

"Well," said Bernard, "if you insist upon it, it's because you are too sharp with me."

"It's because of me. So much as that is true." Bernard wondered what she was going to allude to the most impudent of scandals; then, as she stood opening and closing her pink fan and smiling at him in the fire-light, he felt that she was silly enough for anything. "It's because of all the talk—it's because of Gordon. You needn't be afraid of Gordon."

"Afraid of him? I don't know what you mean," said Bernard, gravely.

Blanche gave a little laugh.

"You have discovered that people are talking about us—about you and me. I must say I wonder you care. I don't care, and if it's because of Gordon, you might as well know that he doesn't care. If he

doesn't care, I don't see why I should; and if I don't, I don't see why you should!"

"You pay too much attention to such vulgar drivels in even mentioning it."

"Well, if I have the credit of saying what I shouldn't—to you or to any one else—I don't see why I shouldn't have the advantage too. Gordon doesn't care—he doesn't care what I do or say. He doesn't care a pin for me!"

She spoke in her usual rattling, rambling voice, and brought out this declaration with a curious absence of resentment.

"You talk about advantage," said Bernard. "I don't see what advantage it is to you to say that."

"I want to—I must—I will! That's the advantage!" This came out with a sudden sharpness of tone; she spoke more excitedly. "He doesn't care a button for me, and he never did! I don't know what he married me for. He cares for something else—he thinks of something else. I don't know what it is—I suppose it's chemistry!"

These words gave Bernard a certain shock, but he had his intelligence sufficiently in hand to contradict them with energy.

"You labor under a monstrous delusion," he exclaimed. "Your husband thinks you fascinating."

This epithet, pronounced with a fine distinctness, was ringing in the air when the door opened and Gordon came in. He looked for a moment from Bernard to his wife, and then, approaching the latter, he said, softly:

"Do you know that he leaves us to-morrow?"

When he arrived in California, Bernard Longueville asked himself why he had come, and was unable to mention any other reason than that he had announced it. He began to feel restless again, and to drift back to those vague dissatisfactions which had accompanied him through his long journey in the East. He succeeded, however, in keeping these unreasonable feelings at bay for some time, and he strove to occupy himself, to take an interest in Californian problems. Bernard, however, was neither a political economist nor a cattle-fancier, and he found that, as the phrase is, there was not a great deal to take hold of. He wandered about, admired the climate and the big peaches, thought a while of going to Japan, and ended by going to Mexico. In this way he passed several months, and justified, in the eyes of other people at

least, his long journey across the Continent. At last he made it again, in the opposite sense. He went back to New York, where the summer had already begun, and here he invented a solution for the difficulty presented by life to a culpably unoccupied and ill-regulated man. The solution was not in the least original, and I am almost ashamed to mention so stale and conventional a device. Bernard simply devised the plan of returning to Europe. Such as it was, however, he carried it out with an audacity worthy of a better cause, and was sensibly happier since he had made up his mind to it. Gordon Wright and his wife were out of town, but Bernard went into the country, as boldly as you please, to inform them of his little project and take a long leave of them. He had made his arrangements to sail immediately, and, as at such short notice it was impossible to find good quarters on one of the English vessels, he had engaged a berth on a French steamer which was to convey him to Havre. On going down to Gordon's house in the country, he was conscious of a good deal of eagerness to know what had become of that latent irritation of which Blanche had given him a specimen. Apparently it had quite subsided. Blanche was wreathed in smiles; she was living in a bower of roses. Bernard, indeed, had no opportunity for investigating her state of mind, for he found several people in the house, and Blanche, who had an exalted standard of the duties of a hostess, was occupied in making life agreeable to her guests, most of whom were gentlemen. She had in this way that great remedy for dissatisfaction which Bernard lacked—something interesting to do. Bernard felt a good deal of genuine sadness in taking leave of Gordon, to whom he contrived to feel even more kindly than in earlier days. He had quite forgotten that Gordon was jealous of him—which he was not, as Bernard said. Certainly, Gordon showed nothing of it now, and nothing could have been more friendly than their parting. Gordon, too, for a man who was never boisterous, seemed very contented. He was fond of exercising hospitality, and he confessed to Bernard that he was just now in the humor for having his house full of people. Fortune continued to gratify this generous taste; for just as Bernard was coming away another guest made his appearance. The new-comer was none other than Captain Augustus Lovelock, who had just arrived in New York, and who, as he added,

had long desired to visit the United States. Bernard merely witnessed his arrival, and was struck with the fact that as he presented himself—it seemed quite a surprise—Blanche really stopped chattering.

CHAPTER VIII.

I HAVE called it a stale expedient on Bernard Longueville's part to "go to Europe" again, like the most commonplace American; and it is certain that, as our young man stood and looked out of the window of his inn at Havre, an hour after his arrival at that sea-port, his adventure did not strike him as having any great freshness. He had no plans or intentions; he had not even any very definite desires. He had felt the impulse to come back to Europe, and he had obeyed it; but now that he had arrived, his impulse seemed to have little more to say to him. He perceived it, indeed—mentally—in the attitude of a small street-boy playing upon his nose with that vulgar gesture which is supposed to represent the elation of successful fraud. There was a large blank wall before his window, painted a dirty yellow and much discolored by the weather. A broad patch of summer sunlight rested upon it and brought out the full vulgarity of its complexion. Bernard stared a while at this blank wall, which struck him in some degree as a symbol of his own present moral prospect. Then suddenly he turned away, with the declaration that, whatever truth there might be in symbolism, he, at any rate, had not come to Europe to spend the precious remnant of his youth in a malodorous Norman sea-port. The weather was very hot, and neither the hotel nor the town at large appeared to form an attractive *séjour* for persons of an irritable nostril. To go to Paris, however, was hardly more attractive than to remain at Havre, for Bernard had a lively vision of the heated bitumen and the glaring frontages of the French capital. But if a Norman town was close and dull, the Norman country was notoriously fresh and entertaining, and the next morning Bernard got into a calèche with his luggage, and bade its proprietor drive him along the coast. Once he had begun to rumble through this charming landscape, he was in much better humor with his situation; the air was freshened by a breeze from the sea; the blooming country, without walls or fences, lay open to the traveler's eye; the grain-fields and copses were shimmering in

the summer wind; the pink-faced cottages peeped through the ripening orchard-boughs, and the gray towers of the old churches were silvered by the morning-light of France.

At the end of some three hours, Bernard arrived at a little watering-place which lay close upon the shore, in the embrace of a pair of white-armed cliffs. It had a quaint and primitive aspect and a natural picturesqueness which commended it to Bernard's taste. There was evidently a great deal of nature about it, and at this moment, nature, embodied in the clear, gay sunshine, in the blue and quiet sea, in the daisied grass of the high-shouldered downs, had an air of inviting the intelligent observer to postpone his difficulties. Blanquais-les-Galets, as Bernard learned the name of this unfashionable resort to be, was twenty miles from a railway, and the place wore an expression of unaffected rusticity. Bernard stopped at an inn for his noonday breakfast, and then, with his appreciation quickened by the homely felicity of this repast, determined to go no further. He engaged a room at the inn, dismissed his vehicle, and gave himself up to the contemplation of French sea-side manners. These were chiefly to be observed upon a pebbly strand which lay along the front of the village and served as the gathering-point of its idler inhabitants. Bathing in the sea was the chief occupation of these good people, including, as it did, prolonged spectatorship of the process and infinite conversation upon its mysteries. The little world of Blanquais appeared to form a large family party, of highly developed amphibious habits, which sat gossiping all day upon the warm pebbles, occasionally dipping into the sea and drying itself in the sun, without any relaxation of personal intimacy. All this was very amusing to Bernard, who in the course of the day took a bath with the rest. The ocean was, after all, very large, and when one took his plunge he seemed to have it quite to himself. When he had dressed himself again, Bernard stretched himself on the beach, feeling happier than he had done in a long time, and pulled his hat over his eyes. The feeling of happiness was an odd one; it had come over him suddenly, without visible cause; but, such as it was, our hero made the most of it. As he lay there it seemed to deepen; his immersion and his exercise in the salt water had given him an agreeable languor. This presently became a drowsiness which was not less agreeable, and Bernard felt himself going to sleep. There were sounds in the air

above his head—sounds of the crunching and rattling of the loose, smooth stones as his neighbors moved about on them; of high-pitched French voices exchanging colloquial cries; of the splash of the bathers in the distant water, and the short, soft breaking of the waves. But these things came to his ears more vaguely and remotely, and at last they faded away. Bernard enjoyed half an hour of that light and easy slumber which is apt to overtake idle people in recumbent attitudes in the open air on August afternoons. It brought with it an exquisite sense of rest, and the rest was not spoiled by the fact that it was animated by a charming dream. Dreams are vague things, and this one had the defects of its species; but it was somehow concerned with the image of a young lady whom Bernard had formerly known, and who had beautiful eyes, into which—in the dream—he found himself looking. He waked up to find himself looking into the crown of his hat, which had been resting on the bridge of his nose. He removed it, and half raised himself, resting on his elbow and preparing to taste, in another position, of a little more of that exquisite rest of which mention has just been made. The world about him was still amusing and charming; the chatter of his companions, losing itself in the large sea-presence, the splash of the divers and swimmers, the deep blue of the ocean and the silvery white of the cliff, had that striking air of indifference to the fact that his mind had been absent from them which we are apt to find in mundane things on emerging from a nap. The same people were sitting near him, on the beach—the same, and yet not quite the same. He found himself noticing a person whom he had not noticed before—a young lady, who was seated in a low portable chair some dozen yards off, with her eyes bent upon a book. Her head was in shade; her large parasol made, indeed, an awning for her whole person, which in this way, in the quiet attitude of perusal, seemed to abstract itself from the glare and murmur of the beach. The clear shadow of her umbrella—it was lined with blue—was deep upon her face; but it was not deep enough to prevent Bernard from recognizing a profile that he knew. He suddenly sat upright, with an intensely quickened vision. Was he dreaming still, or had he waked? In a moment he felt that he was acutely awake; he heard her, across the interval, turn the page of her book. For a single instant, as she did so,

she looked with level brows at the glittering ocean; then, lowering her eyes, she went on with her reading. In this barely perceptible movement he saw Angela Vivian; it was wonderful how well he remembered her. She was evidently reading very seriously; she was much interested in her book. She was alone; Bernard looked about for her mother, but Mrs. Vivian was not in sight. By this time Bernard had become aware that he was agitated; the exquisite rest of a few moments before had passed away. His agitation struck him as unreasonable; in a few minutes he made up his mind that it was absurd. He had done her an injury—yes; but as she sat there losing herself in a French novel—Bernard could see it was a French novel—he could not make out that she was the worse for it. It had not affected her appearance; Miss Vivian looked admirably pretty. Bernard hoped she would not look toward him or recognize him; he wished to look at her at his ease; to think it over; to make up his mind. The idea of meeting Angela Vivian again had often come into his thoughts; I may, indeed, say that it was a tolerably familiar presence there; but the fact, nevertheless, now presented itself with all the violence of an accident for which he was totally unprepared. He had often asked himself what he should say to her, how he should carry himself, and how he should probably find the young lady; but, with whatever ingenuity he might at the moment have answered these questions, his intelligence at present felt decidedly overtaxed. She was a very pretty girl, to whom he had done a wrong; this was the final attitude into which, with a good deal of preliminary shifting and wavering, she had settled in his recollection. The wrong was a right, doubtless, from certain points of view; but from the girl's own it could only seem an injury to which its having been inflicted by a clever young man with whom she had been on agreeable terms, necessarily added a touch of baseness.

In every disadvantage that a woman suffers at the hands of a man, there is inevitably, in what concerns the man, an element of cowardice. When I say "inevitably," I mean that this is what the woman sees in it. This is what Bernard believed that Angela Vivian saw in the fact that by giving his friend a bad account of her he had prevented her making an opulent marriage. At first he had said to himself that, whether he had held his tongue or spoken, she had already lost her chance; but with time, somehow,

this reflection had lost its weight in the scale. It conveyed little re-assurance to his irritated conscience—it had become imponderable and impertinent. At the moment of which I speak it entirely failed to present itself, even for form's sake; and as he sat looking at this handsome girl who came back to him out of an episode of his past, he thought of her simply as an unprotected woman toward whom he had been indelicate. It is not an agreeable thing for a delicate man like Bernard Longueville to have to accommodate himself to such an accident, but this is nevertheless what it seemed needful that he should do. If she bore him a grudge he must think it natural; if she vowed him a hatred he must allow her the comfort of it. He had done the only thing possible, but that made it no better for her. He had wronged her. The circumstances mattered nothing, and as he could not make it up to her, the only reasonable thing was to keep out of her way. He had stepped into her path now, and the proper thing was to step out of it. If it could give her no pleasure to see him again, it could certainly do him no good to see her. He had seen her by this time pretty well—as far as mere seeing went, and as yet, apparently, he was none the worse for that; but his hope that he should himself escape unperceived had now become acute. It is singular that this hope should not have led him instantly to turn his back and move away; but the explanation of his imprudent delay is simply that he wished to see a little more of Miss Vivian. He was unable to bring himself to the point. Those clever things that he might have said to her quite faded away. The only good taste was to take himself off, and spare her the trouble of inventing civilities that she could not feel. And yet he continued to sit there from moment to moment, arrested, detained, fascinated, I may almost say, by the accident of her not looking round—of her letting him watch her so long. She turned another page, and another, and her reading absorbed her still. He was so near her that he could have touched her dress with the point of his umbrella. At last she raised her eyes and rested them a while on the blue horizon, straight in front of her, but as yet without turning them aside. This, however, augmented the danger of her doing so, and Bernard, with a good deal of an effort, rose to his feet. The effort, doubtless, kept the movement from being either as light or as swift as it might have been, and it vaguely

attracted his neighbor's attention. She turned her head and glanced at him, with a glance that evidently expected but to touch him and pass. It touched him, and it was on the point of passing; then it suddenly checked itself; she had recognized him. She looked at him, straight and open-eyed, out of the shadow of her parasol, and Bernard stood there—motionless now—receiving her gaze. How long it lasted need not be narrated. It was probably a matter of a few seconds, but to Bernard it seemed a little eternity. He met her eyes, he looked straight into her face; now that she had seen him he could do nothing else. Bernard's little eternity, however, came to an end; Miss Vivian dropped her eyes upon her book again. She let them rest upon it only a moment; then she closed it and slowly rose from her chair, turning away from Bernard. He still stood looking at her—stupidly, foolishly, helplessly enough, as it seemed to him; no sign of recognition had been exchanged. Angela Vivian hesitated a minute; she now had her back turned to him, and he fancied her light, flexible figure was agitated by her indecision. She looked along the sunny beach, which stretched its shallow curve to where the little bay ended and the white wall of the cliffs began. She looked down toward the sea, and up toward the little Casino which was perched on a low embankment, communicating with the beach at two or three points by a short flight of steps. Bernard saw—or supposed he saw—that she was asking herself whither she had best turn to avoid him. He had not blushed when she looked at him—he had rather turned a little pale; but he blushed now, for it really seemed odious to have literally driven the poor girl to bay. Miss Vivian decided to take refuge in the Casino, and she passed along one of the little pathways of planks that were laid here and there across the beach, and directed herself to the nearest flight of steps. Before she had gone two paces a complete change came over Bernard's feeling; his only wish now was to speak to her—to explain—to tell her he would go away. There was another row of steps at a short distance behind him; he rapidly ascended them and reached the little terrace of the Casino. Miss Vivian stood there; she was apparently hesitating again which way to turn. Bernard came straight up to her, with a gallant smile and a greeting. The comparison is a coarse one, but he felt that he was taking the bull by the horns. Angela Vivian stood watching him arrive.

"You didn't recognize me," he said, "and your not recognizing me made me—made me hesitate."

For a moment she said nothing, and then: "You are more timid than you used to be!" she answered.

He could hardly have said what expression he had expected to find in her face; his apprehension had, perhaps, not painted her obtrusively pale and haughty, aggressively cold and stern; but it had figured something different from the look he encountered. Miss Vivian was simply blushing—that was what Bernard mainly perceived; he saw that her surprise had been extreme—complete. Her blush was re-assuring; it contradicted the idea of impatient resentment, and Bernard took some satisfaction in noting that it was prolonged.

"Yes, I am more timid than I used to be," he said.

In spite of her blush, she continued to look at him very directly; but she had always done that—she always met one's eye; and Bernard now instantly found all the beauty that he had ever found before in her pure, unevasive glance.

"I don't know whether I am more brave," she said; "but I must tell the truth—I instantly recognized you."

"You gave no sign!"

"I supposed I gave a striking one—in getting up and going away."

"Ah!" said Bernard, "as I say, I am more timid than I was, and I didn't venture to interpret that as a sign of recognition."

"It was a sign of surprise."

"Not of pleasure!" said Bernard. He felt this to be a venturesome, and from the point of view of taste perhaps a reprehensible, remark; but he made it because he was now feeling his ground, and it seemed better to make it gravely than with assumed jocosity.

"Great surprises are to me never pleasures," Angela answered; "I am not fond of shocks of any kind. The pleasure is another matter. I have not yet got over my surprise."

"If I had known you were here, I would have written to you beforehand," said Bernard, laughing.

Miss Vivian, beneath her expanded parasol, gave a little shrug of her shoulders.

"Even that would have been a surprise."

"You mean a shock, eh? Did you suppose I was dead?"

Now, at last, she lowered her eyes, and her blush slowly died away.

"I knew nothing about it."

"Of course you couldn't know, and we are all mortal. It was natural that you shouldn't expect—simply on turning your head—to find me lying on the pebbles at Blanquais-les-Galets. You were a great surprise to me, as well; but I differ from you—I like surprises."

"It is rather refreshing to hear that one is a surprise," said the girl.

"Especially when in that capacity one is liked!" Bernard exclaimed.

"I don't say that—because such sensations pass away. I am now beginning to get over mine."

The light mockery of her tone struck him as the echo of an unforgotten air. He looked at her a moment, and then he said:

"You are not changed; I find you quite the same."

"I am sorry for that!" And she turned away.

"What are you doing?" he asked.

"Where are you going?"

She looked about her, without answering, up and down the little terrace. The Casino at Blanquais was a much more modest place of reunion than the Conversation-house at Baden-Baden. It was a small, low structure of brightly painted wood, containing but three or four rooms, and furnished all along its front with a narrow covered gallery, which offered a delusive shelter from the rougher moods of the fine, fresh weather. It was somewhat rude and shabby—the subscription for the season was low—but it had a simple picturesqueness. Its little terrace was a very convenient place for a stroll, and the great view of the ocean and of the marble-white crags that formed the broad gate-way of the shallow bay, was a sufficient compensation for the absence of luxuries. There were a few people sitting in the gallery, and a few others scattered upon the terrace; but the pleasure-seekers of Blanquais were, for the most part, immersed in the salt water or disseminated upon the grassy downs.

"I am looking for my mother," said Angela Vivian.

"I hope your mother is well."

"Very well, thank you."

"May I help you to look for her?" Bernard asked.

Her eyes paused in their quest, and rested a moment upon their companion.

"She is not here," she said presently.

"She has gone home."

"What do you call home?" Bernard demanded.

"The sort of place that we always call home; a bad little house that we have taken for a month."

"Will you let me come and see it?"

"It's nothing to see."

Bernard hesitated a moment.

"Is that a refusal?"

"I should never think of giving it so fine a name."

"There would be nothing fine in forbidding me your door. Don't think that!" said Bernard, with rather a forced laugh.

It was difficult to know what Miss Vivian thought; but she said, in a moment:

"We shall be very happy to see you. I am going home," she added.

"May I walk with you so far?" asked Bernard.

"It is not far; it's only three minutes." And Angela moved slowly to the gate of the Casino.

Bernard walked beside her, and for some moments nothing was said between them. As the silence continued, he became aware of it, and it vexed him that she should leave certain things unsaid. She had asked him no question—neither whence he had come, nor how long he would stay, nor what had happened to him since they parted. He wished to see whether this was intention or accident. He was already complaining to himself that she expressed no interest in him, and he was perfectly aware that this was a ridiculous feeling. He had come to speak to her in order to tell her that he was going away, and yet, at the end of five minutes, he had asked leave to come and see her. This sudden gyration of mind was grotesque, and Bernard knew it; but, nevertheless, he had an immense expectation that, if he should give her time, she would manifest some curiosity as to his own situation. He tried to give her time; he held his tongue; but she continued to say nothing. They passed along a sort of winding lane, where two or three fishermen's cottages, with old brown nets suspended on the walls and drying in the sun, stood open to the road, on the other side of which was a patch of salt-looking grass, browsed by a donkey that was not fastidious.

"It's so long since we parted, and we have so much to say to each other!" Bernard exclaimed at last, and he accompanied this declaration with a laugh much more spontaneous than the one he had given a few moments before.

It might have gratified him, however, to observe that his companion appeared to see

no ground for joking in the idea that they should have a good deal to say to each other.

"Yes, it's a long time since we spent those pleasant weeks at Baden," she rejoined.

"Have you been there again?"

This was a question, and though it was a very simple one, Bernard was charmed with it.

"I wouldn't go back for the world!" he said. "And you?"

"Would I go back? Oh yes; I thought it so agreeable."

With this he was less pleased; he had expected the traces of resentment, and he was actually disappointed at not finding them. But here was the little house of which his companion had spoken, and it seemed, indeed, a rather bad one. That is, it was one of those diminutive structures which are known at French watering-places as "*chalcets*," and, with an exiguity of furniture, are let for the season to families that pride themselves upon their powers of contraction. This one was a very humble specimen of its class, though it was doubtless a not inadequate abode for two quiet and frugal women. It had a few inches of garden, and there were flowers in pots in the open windows, where some extremely fresh white curtains were gently fluttering in the breath of the neighboring ocean. The little door stood wide open.

"This is where we live," said Angela; and she stopped and laid her hand upon the little garden-gate.

"It's very nice," said Bernard. "I think it's better than the pastry-cook's at Baden."

They stood there, and she looked over the gate at the geraniums. She did not ask him to come in; but, on the other hand, keeping the gate closed, she made no movement to leave him. The Casino was now quite out of sight, and the whole place was perfectly still. Suddenly, turning her eyes upon Bernard with a certain strange inconsequence:

"I haven't seen you here before," she observed.

He gave a little laugh.

"I suppose it's because I only arrived this morning. I think that if I had been here you would have noticed me."

"You arrived this morning?"

"Three or four hours ago. So, if the remark were not in questionable taste, I should say we had not lost time."

"You may say what you please," said Angela, simply. "Where did you come from?"

Interrogation, now it had come, was most satisfactory, and Bernard was glad to believe that there was an element of the unexpected in his answer.

"From New York."

"You came straight from New York to this place?"

"I arrived at Havre only yesterday."

"And why did you come here?"

"It would be graceful of me to be able to answer—'Because I knew you were here.' But unfortunately I did not know it. It was a mere chance; or rather I feel like saying it was an inspiration."

Angela looked at the geraniums again.

"It was very odd," she said. "We might have been in so many places besides this one. And you might have come to so many places besides this one."

"It is all the more singular, that one of the last persons I saw in America was your charming friend Blanche, who married Gordon Wright. She didn't tell me you were here."

"She had no reason to know it," said the girl. "She is not my friend—as you are her husband's friend."

"Ah no, I don't suppose that. But she might have heard from you."

"She doesn't hear from us. My mother used to write to her for a while after she left Europe, but she has given it up." She paused a moment, and then she added—"Blanche is too silly!"

Bernard noted this, wondering how it bore upon his theory of a spiteful element in his companion. Of course Blanche was silly; but, equally of course, this young lady's perception of it was quickened by Blanche's having married a rich man whom she herself might have married.

"Gordon doesn't think so," Bernard said.

Angela looked at him a moment.

"I am very glad to hear it," she rejoined, gently.

"Yes, it is very fortunate."

"Is he well?" asked Miss Vivian. "Is he happy?"

"He has all the air of it."

"I am very glad to hear it," she repeated. And then she moved the latch of the gate and passed in. At the same moment her mother appeared in the open door-way. Mrs. Vivian had apparently been summoned by the sound of her daughter's colloquy with an unrecognized voice, and when she saw Bernard she gave a sharp little cry of surprise. Then she stood gazing at him.

Since the dispersion of the little party

at Baden-Baden he had not devoted much meditation to this conscientious gentlewoman who had been so tenderly anxious to establish her daughter properly in life; but there had been in his mind a tacit assumption that if Angela deemed that he had played her a trick Mrs. Vivian's view of his conduct was not more charitable. He felt that he must have seemed to her very unkind, and that in so far as a well-regulated conscience admitted the exercise of unpractical passions, she honored him with a pointed detestation. The instant he beheld her on her threshold this conviction rose to the surface of his consciousness and made him feel that now, at least, his hour had come.

"It is Mr. Longueville, whom we met at Baden," said Angela to her mother, gravely.

Mrs. Vivian began to smile, and stepped down quickly toward the gate.

"Ah, Mr. Longueville," she murmured, "it's so long—it's so pleasant—it's so strange—"

And suddenly she stopped, still smiling. Her smile had an odd intensity; she was trembling a little, and Bernard, who was prepared for hissing scorn, perceived with a deep, an almost violent, surprise, a touching agitation, an eager friendliness.

"Yes, it's very long," he said; "it's very pleasant. I have only just arrived; I met Miss Vivian."

"And you are not coming in?" asked Angela's mother, very graciously.

"Your daughter has not asked me!" said Bernard.

"Ah, my dearest," murmured Mrs. Vivian, looking at the girl.

Her daughter returned her glance, and then the elder lady paused again, and simply began to smile at Bernard, who recognized in her glance that queer little intimation—shy and cautious, yet perfectly discernible—of a desire to have a private understanding with what he felt that she mentally termed his better nature, which he had more than once perceived at Baden-Baden.

"Ah no, she has not asked me," Bernard repeated, laughing gently.

Then Angela turned her eyes upon him, and the expression of those fine organs was agreeably striking. It had, moreover, the merit of being easily interpreted; it said very plainly, "Please don't insist, but leave me alone." And it said it not at all sharply,—very gently and pleadingly. Bernard found himself understanding it so well that he literally blushed with intelligence.

"Don't you come to the Casino in the evening, as you used to come to the Kur-saal?" he asked.

Mrs. Vivian looked again at her daughter, who had passed into the door-way of the cottage; then she said:

"We will go this evening."

"I shall look for you eagerly," Bernard rejoined. "*Auf wiedersehen*, as we used to say at Baden!"

Mrs. Vivian waved him a response over the gate, her daughter gave him a glance from the threshold, and he took his way back to his inn.

He awaited the evening with great impatience; he fancied he had made a discovery, and he wished to confirm it. The discovery was that his idea that she bore him a grudge, that she was conscious of an injury, that he was associated in her mind with a wrong, had all been a morbid illusion. She had forgiven, she had forgotten, she didn't care, she had possibly never cared! This, at least, was his theory now, and he longed for a little more light upon it. His old sense of her being a complex and intricate girl had, in that quarter of an hour of talk with her, again become lively, so that he was not absolutely sure his apprehensions had been vain. But, with his quick vision of things, he had got the impression, at any rate, that she didn't care in a small way for any slight he might have put upon her, or any disadvantage he might have caused her. Her feeling about such a matter would be large and original. Bernard desired to see more of that, and in the evening, in fact, it seemed to him that he did so.

The terrace of the Casino was far from offering the brilliant spectacle of the promenade in front of the gaming-rooms at Baden. It had neither the liberal illumination, the distinguished frequenters, nor the superior music which formed the attraction of that celebrated spot; but it had a modest animation of its own, in which the starlight on the open sea took the

place of clustered lamps, and the strong murmur of the waves performed the function of an orchestra. Mrs. Vivian made her appearance with her daughter, and Bernard, as he used to do at Baden, chose a corner to place some chairs for them. The crowd was small, for most of the visitors had compressed themselves into one of the rooms where a shrill operetta was being performed by a strolling troupe. Mrs. Vivian's visit was a short one; she remained at the Casino less than half an hour. But Bernard had some talk with Angela. He sat beside her—her mother was on the other side, talking with an old French lady whose acquaintance she had made on the beach. Between Bernard and Angela several things were said. When his friends went away Bernard walked home with them. He bade them good-night at the door of their chalet, and then slowly strolled back to the Casino. The terrace was nearly empty; every one had gone to listen to the operetta, the sound of whose contemporary gayety came through the open, hot-looking windows in little thin quavers and catches. The ocean was rumbling just beneath; it made a ruder but richer music. Bernard stood looking at it a moment; then he went down the steps to the beach. The tide was rather low; he walked slowly down to the line of the breaking waves. The sea looked huge and black and simple; everything was vague in the unassisted darkness. Bernard stood there some time; there was nothing but the sound and the sharp, fresh smell. Suddenly he put his hand to his heart; it was beating very fast. An immense conviction had come over him—abruptly, then and there—and for a moment he held his breath. It was like a word spoken in the darkness,—he held his breath to listen. He was in love with Angela Vivian, and his love was a throbbing passion! He sat down on the stones where he stood—it filled him with a kind of awe.

(To be continued.)

BAYARD TAYLOR.

HIS POETRY AND LITERARY CAREER.

A CONSECRATING hand has led Bayard Taylor to a station more remote than the places where our elder and most assured poets are seated. He is transfigured and with the immortals. He was taken in his prime, with work spread all before him; yet what he did, and the record of his career, may now be used to illustrate the time and region in which it was his lot to move. No longer a living comrade, we may strive to free our judgment from bias of rivalry or affection. Injustice cannot touch him,—

“No ominous hour
Knocks at his door with tidings of mishap.
Far off is he, above desire and fear;
No more subjected to the change and chance
Of the unsteady planets.”

As for our love for one so lately with us,—if a tear should fall unawares, it need not blur those words which prove that our loyalty to the art we serve in common is not forgotten in the tenderness which we extend to one another, or in weaker moments half count on for ourselves.

Many have thought that Taylor was fortune's favorite; that for him there were no unsteady planets, and that the lamp of his success never burned obscure. His life was notable, indeed, and from slight beginnings he achieved much. But success must be judged from within. What is a man's aim? Has he attained it? If not, what hindered him? After such questionings, we learn that the career of Bayard Taylor had, too, its adverse star.

I.

WE find ourselves observing a true poet whose abundant writings fail to express the whole measure of his genius. He was even more than these relics imply. Circumstances diffused and modified the outcome of his rarest gift. I do not think that the advantages which his art-life affords, as an object of critical regard, have been fully valued. What American poet ever touched life and letters more variously? He let nothing go by him, he essayed everything, and furnishes examples of what to do—and what to avoid. My longest chapter is required for the study of a character wholly unique; not that he was our foremost singer, but that

his progress was so involved with the literary action of his time. The greatest modern critic devoted works and days to the analysis of personages far less noteworthy, whether the Pennsylvanian be regarded as a character or as a poet. We now are enabled, besides, to accept his story as illustrative of American authorship under somewhat different conditions from those which have affected the Cambridge group, and, secondly, of a period whose bisecting line is curiously indicated by the date of the beginning of our civil war.

This country is too broad and varied to adjust itself to one center, and must have many capitals, east and west; if any city thus far is both its material and mental equivalent, that city is New York. Here nothing has fully ripened; time is needed for the completion of what the outlines suggest. Boston, the capital of a section, was enabled sooner to define her idealism, to reach a standard, and to afford a holding-ground for schools of taste and thought. In her shaded suburbs poesy, letters, divine philosophy, have flourished, gaining a lovely and secure retreat. She bears the title of the New-World Athens, for she has afforded in miniature a model of what a metropolis, representing the various sections of our country, and all the temperaments and interests of our people, must hereafter exhibit on a splendid and comprehensive scale.

Meanwhile, the task laid upon the pioneers of letters in New York has been sufficiently hard,—always the need of devotion, toil, patient laying of foundations on which others shall build. Inherited names and resources, and the vantage of university life, have sustained the growth of a New England school. Poets who have strayed into New York—and here they are more seldom born than imported—have carried the harp with one hand and some instrument of labor with the other, and have sung their songs in such noonings as they could obtain. Almost without exception, during recent times, they have been thrown upon journalism for a support, and have experienced whatever good and evil that profession brings to the æsthetic sense of its practitioner. The laurels, the right and might of reputation, have belonged chiefly to the Old Colony, as was inevitable; and Poe's constant protest, thirty

years ago, against a disposition to believe that nothing good could arise elsewhere, useless and unmanly as it may have been, was not without reason.

Bayard Taylor, however, was not only a more sturdy and courageous example of a poet born out of New England, but must be studied with the period already named. Younger than our chief poets still living, he stood with a few companions—like Stoddard, Boker, Read—who found their music broken in upon by the tumult of a national war. Never was there a more inharmonious and changeful epoch. Wars are storms which introduce new seasons. Thus, we are to consider the writings of a poet, who dates half-way between the elder and the rising generations; who was not of Cambridge, nor of Concord, but from the Middle States; one, finally, in whose works although the product of a life of action, we always discern the influences of the study and the hearth.

II.

TAYLOR was rightly termed the most versatile of our authors. The variety of his work impressed all. Was this the result of constitutional tendency, or due to the exigencies of American life and of his own life in particular? The problem is a close one, but surely his versatility and the crowded summary of his labors make him a very difficult poet to examine. True, he does not belong to the class, among whom both great and small are to be found, of those who—whether from greatness or littleness—have composed in such wise that their own tastes and feelings cannot be predicated from their works. He often wrote subjectively, yet was one, I think, whose natural gift could as well be understood through his personal qualities. His presence and story were so live and instant before us as to offer fine paradigms of the birth and breeding of a poet. A critic, reflecting upon the tricks of poetic diletanteism, takes kindly to verse which has a man behind it. He strives to put himself in harmony with the inner life of such a singer, to be with him in his youth, manhood, and intellectual prime,—to measure his ideals no less than his performances,—to feel his aids and restrictions,—to breathe, as it were, the very breath of his inspiration.

See, then, the region from which this poet came, and bear in mind the kinship

that exists between the fields, the trees, the air, and all living and sentient things belonging to a given spot of earth. Go back to the happy pastoral county of the central State, which produced Bayard Taylor from its oldest and purest Quaker stock. Here lie broad undulating meadows and woodlands, as of some imagined section that should be wholly characteristic of the temperate zone. Here Nature has no extremes of grandeur or picturesqueness, nor any gloomy aspects, but is kindly, simple, attractive, strong; here she reaches, as in English rural landscape, her perfect balance, blending all her attributes in just proportion. The sons of such a soil are rounded and even in their make, sound of brawn and brain, open to many phases of life,—not likely, once having touched the outer world, to content themselves with one experience, or one purpose, whether morbid or healthy and well-conceived.

More than other youths, Bayard took in the nourishment which nature offered him. His sensibilities and instincts were those of her poets and artists. The trees, the flowers, the grasses, he knew them all; he was no sportsman, but "named all the birds without a gun." His farming duties often were forgotten in roving and reveries, and charmed moods uncomprehended either by himself or by those about him. Then the eager devouring of books,—old-fashioned novels, history, travels; above all, of the poetry within his reach. The story of his boyhood is told by his teachers, and with feeling and intelligence by Judge Lewis; it is written on the memories and narrated by the faltering voices of those aged parents who, after sixty years of wedlock, find the home in which he placed them made desolate by the loss of the faithful son. His youth was that of the traditional American boy, and here, as always, the story of *Rasselas* repeats itself. The fairest native valley palls upon the lad who as yet has nothing by which to measure its worth. Tranquillity for the old; for the young, a longing for new and larger experiences. But time rights all things: as no town-bred person ever really knows the country, so no country-lad in older years forgets the secrets nature taught his childhood. Taylor had through life the frank and somewhat homely simplicity of the yeoman, thorough cosmopolite as he was. And in time he learned how glad his youth had been, and with a great desire again and again returned to the pastoral walks of Kennett.

The boy's impatience of his confines was early shown. After the schooling at a country academy, where he studied hard and well, came the revolt from farm-life and the alternative selection of a trade. Of course he chose to be a printer, and at the age of seventeen became an apprentice in Westchester. Already he had found his gift of making verses, and now took fire with the thought of being a poet. The publication of his juvenile pieces grew out of his desire to see the world. He contrived to open a correspondence with the literary magnates, Willis and Griswold. Two years were passed in this novitiate; he then managed to cancel his indentures, and forced his way out of that life and into the one his heart was set upon.

I have seen his mother's copy of the thin little book, now so hard to find, entitled "Ximena; or, The Battle of the Sierra Morena, and other Poems." It was dedicated to Griswold, in gratitude for "kind encouragement" shown the author. On the fly-leaf is written, in a clear hand, "Rebecca W. Taylor, from her affectionate son, J. Bayard Taylor."* The poet had reason for the touching devotion he always showed to this noble woman. "The mother makes us most." He strikingly resembled her in features; certainly he inherited from her his courage and virtue, his broad sympathies, much of his literary talent, and a sane and cheerful mind.

The course of his early readings is seen in this collection. Byron, Scott, Moore, Mrs. Hemans, Bryant, are echoed here and there. The title-poem is a tale of the Cid, fairly written in octosyllabics, with a prelude in the measure of "Childe Harold." Griswold narrates that he gave the callow author sound advice as to a modern and native field for his later efforts. The boy's own feelings are expressed in shorter pieces—one of them entitled "Manhood." He cherished a high ideal of life,—patriotic, aspiring, pure,—really such an ideal as we like to attribute to the best type of the American youth. A blank-verse poem is inscribed to Whittier, whose name was a household word in the Quaker home.

* The poet was named Bayard after James A. Bayard of Delaware, grandfather of the present Senator. He prefixed the initial "J," in signing his youthful pieces, "thinking it would look better." Griswold put "James Bayard" on this title-page. Upon his twenty-first birthday Taylor had the good sense to resume his original signature, which he never afterward changed.

Though the book contained no new note, it did show the ambition and facile gift of the born writer. One quality is apparent which afterward marked his verse,—a peculiar sonorousness, especially in the use of resonant proper nouns, the names of historic persons and places. In a lyric, "The Old World," written about this time, he avowed his impatience with his tame stay-at-home life. "Ximena" was printed at a venture, solely for the purpose of increasing the savings with which to undertake a tramp over Europe, at that time an audacious and almost fanciful design. From the proceeds he was enabled to see those patrons in Philadelphia who advanced him, on the pledge of his future labors, the sum of \$140, which encouraged him to set out upon his travels. After reaching New York he hastened to the "Tribune" office, even at that time the Mecca of rustic aspirants, few of whom placed too modest a valuation upon their own powers. However, it was no common youth, this stripling of nineteen, who won the affectionate interest of Horace Greeley, and already had found practical friends in Willis, Griswold, Godwin, and the triumvirate of the Philadelphia press,—Patterson, Chandler, and the kindly editor of "Graham's Magazine."

Here I may as well pause to consider the sentiment of the travels which employed so large a portion of his life, and the quality of their record. The latter began in 1846 with the famous "Views Afoot," and ended with "Egypt and Iceland in the Year 1874," at a date only five years previous to the sudden close of his career.

The gist of the whole matter is that Taylor was a poet upon his travels. A national instinct was expressed in the going out of this wiry, erect, impetuous young man, "to see the world." The same yearning that brings a Western youth to the Atlantic shore has sent our coast-born lads on strange voyages to many lands. Each of them, like the sailor-boy, can nevermore endure "to sit with empty hands at home." Grant White avers that while the air of England was yet new to him, he felt that it was something he was "born to breathe." In England, the counterpart of our feeling is a sense of imprisonment. Britain is the noblest island in the world, but still an island. For us the old strangeness and distance no more yield the charm which belonged to the pages of Irving and Willis and Mitchell. Swift inter-communication, making all countries one, has brought the reaction. We begin to

cherish our own distinctiveness, to seek for our local color. This is a good omen, and the promise of a true development.

In Taylor's case no home-ambition, not even the following of an art, could restrain his desire for travel. He went abroad for his personal delight, that he might see and learn and grow. His journals were undertaken chiefly to give him the means of adventure. He made no scientific pretensions. He was something of a botanist, a natural geographer, could see the form beneath the color, and had enough of exact knowledge to make his narrative rich and intelligible. Before all, he sought the delight of the eye, and that series of sensations which Pater declares to be the sum of life. He had a poet's sense of the best everywhere, and a poet's sympathy with any land to which he came. Hence the effect of his travels is that we journey with him, and enjoy his own emotions. We see with his eyes the Holy City; with him we smell the thyme upon Hymettus, or hear the surges prophesying to the rocks of Tyre. We experience his passion to reach the summits, the ultimate deserts, the extreme capes. Such is the spirit of his *Travels*. We read much in them of scenery and external things; he reserved for his private letters what he had to say of the men and women whose friendship he gained. His perceptions enabled him, though going rapidly over many regions, to get the special quality of each. In all these books there is the clear vision and essential truth of the poet. They are not literary, not poetic, but so depicting life and landscape as to breed something of poetry in us as we read: straightforward, luminous, reciting everything simply, after the Greek fashion,—a series of truthful wonder-tales. If they are a reporter's letters, they are those of a poet acting as reporter. Few travelers have written so much and so honestly. Taylor took little on hearsay. He wrote of what he saw, and saw with unerring eyes. A resident of India said that his book on that country was the only one free from error. It is surprising that this man, the author of eleven volumes of travels, the journals of thirty years, so rarely was challenged, in this precise and exacting time, for a statement made upon the printed page.

Viewing his travels in this light, I have little to add in respect to their literary merits. The style is that of genuine prose; no singsong and sentimentalism; a clear and wholesome medium of expression. Its two extremes—of compact polish and unstudied

freshness,—are to be found, the one in that collection of sketches which was almost his last, the "By-Ways of Europe," and the other in the romantic "Views Afoot"—the story of his first tour, and whose publication made his first literary success. One compensation is to be derived from the descriptive, unscientific method of the series: statistics of resources, politics, laws, must change from year to year; but landscape and atmosphere long remain substantially the same. In science, only the latest works have current value; these travels, contrary to superficial opinion, may not pass out of favor so quickly as those of many who have journeyed upon facts and theories intent.

"Views Afoot" gave Taylor a popularity seldom accorded to so young an author. It made him widely known, and invested him with a friendly interest. His connections were influential. The journal to whose staff he was attached, which had an immense inland circulation, and with whose radical tenets he was in sympathy, found profit in advancing his reputation.

Early and instant success, and the ear of the public,—great things for any author,—are yet not without peril to the faculty divine of the poet. In the intervals of travel, Taylor had kept up the habit of putting his impressions into verse. In 1848, two years after his return, he printed the "Rhymes of Travel." The preface stated that this was the first venture to which he had "intrusted a hope of success, for the sake of Poetry alone." Forty-four pieces made the collection, one-third of which the author afterward excluded from the general edition of his poems. Among the best-remembered lyrics is "A Bacchic Ode." A few Western ballads gave freshness to the book. It was approved by Poe, who found imaginative eloquence in Taylor's style, but on the whole these Rhymes do not seem to me remarkable even as a poet's first offering. Bayard was now twenty-four years old, and surely, recalling the work of Bryant, and Keats, and Shelley, at or before the same age, could not be thought a precocious singer. There was little then in American life to stimulate precocity in song. Besides, his nature was so ardent, so full-blooded, that slight and common sensations intoxicated him, and he estimated their effect, and his power to transmit it to others, beyond the true value. He was too unjaded to require the stimulus for his emotions which many need, and to reach for subtler and more profound imaginings.

Nothing so quaintly and forcibly indicates the place he now held, and the conception formed of him by his readers, as the sentimental portrait by Buchanan Read which served as a frontispiece to the "Rhymes of Travel." How far-away seem those bucolic days, when art indulged itself in freaks like this! The steel engraving gives us Taylor as he pauses in the act of climbing the Alps. A slender youth, in face and form resembling Shelley, and equipped like one of Bunyan's Pilgrims, with a palmer's hat, blouse and belt, and a shepherd's crook in his hand for an alpenstock; lofty peaks in the background! All deliciously operatic and impossible. Such was the popular notion of Taylor, and it often brought out a merry laugh from himself and his friends in later and more realistic years. But those were simple, fortunate times for the young minstrel, who took his success modestly and gladly, nor forgot his work withal; and he now enjoyed a season as poetic as ever afterward came to him, or ever has lightened the spirits of any other votary of work and song.

Indeed, he now was in circumstances more favorable than in later years for the cultivation of his art as a poet. He had secured the means of support, and formed associations which gave him the fellowship and pleasant rivalry of comrades in taste and ambition. He got hold of what he needed, art-life, and embraced it with a zest. Through his established success, and his hold upon journalism, he could aid and encourage his friends, and they in turn did good to his hand and training. Sooth to say, he prized his humble poetic life far more than his sudden honors; it always was first in his affections. He loved his brother bards with the full strength of his large mold, gave them freely of his praise, and frankly welcomed their appreciation in return. He grew as a poet, and his work speedily showed it.

In 1849, a newspaper mission to the new Eldorado gave him some picturesque themes. In that pioneer time the scenes and groups upon the Pacific coast had not the native homogeneous aspect which Bret Harte, for example, has caught and used so well. But there was a breezy, attractive atmosphere in the pictures of Taylor's "Californian Ballads," and a ringing vigor in their tone. Stoddard and himself had met shortly before this journey. They were within a year of each other in age, and their friendship, when Taylor settled

down again to city journalism, became close and stimulative. The aspirations of the two poets were the same. They held sweet counsel together in their sky-chambers, and wrote and studied in concert. Their books were dedicated to each other. Stoddard's "Triumphal Music" was a companion-piece to one of Taylor's; his "Caliban, the Witch's Whelp," was a contrast to the latter's "Ariel in the Cloven Pine." Soon Boker, of Philadelphia, a year or two their senior,—born to what Griswold termed "a life of opulent leisure," but always the unpretentious ally of his brother-poets,—became the third in a chivalrous trio. His "Calaynos" had given him reputation as a dramatic poet. A life-long friendship was established among the three. All this seems the memory of salad-days, but it is from such enthusiasms that new poetic fashions grow. These poets, and with them Read and others, did the best their time and surroundings suggested. Their tastes, all things considered, were sincere and good. If they originated little, it was partly because a fog hung about them, through which was heard the chattering of the so-called "literati"; but they sang merrily, and formed a hopeful group outside of the select circle in the East, and certainly made a promising advance upon the dead level of the "Knickerbocker" school. Their work was essential, possibly, to what has since been done or is yet to come, and cannot be overlooked in any review of that time. The young fellows were in earnest, setting their art before themselves, thinking less of notoriety than of what honors might come from true allegiance to the muse of song.

How could some of them foresee—who would have wished them to foresee—that the rust of years, the weariness of unappreciated work, the scant requitals of a half-formed Philistine market, would gradually wear upon them, slacken their labors, tire their hands, prematurely whiten their hairs; bring them even to make light of their ideal, if in their hearts still true to their early love! There is much in "being born at the right time."

Ten years more, and younger poets were added to the group,—O'Brien, Aldrich, and others,—among whom Taylor was a central figure, holding the friendship of all. Meanwhile, as has been said, these Arcadian influences had told upon his genius. After responding with a conventional poem, "The American Legend," to the honor of a sum-

mons to read the Phi Beta Ode at Harvard, he brought out in Boston, under the classic auspices of the Ticknor house, a volume which gave the first adequate measure of his lyrical powers. "A Book of Romances, Lyrics and Songs" (1851) contained pieces that still rank among the best he wrote. Here is the style, quite matured, which seems most genuinely his own. The longest poem, "Monda-Min; or, the Romance of Maize," shows to less advantage than the rest of the book. It is a version of an Indian legend akin to that upon which Longfellow afterward based his far more important work, "Hiawatha," and is quietly done; but with descriptive truth and occasional touches of strength and originality. The chief value of the collection was in miscellaneous pieces that have the lasting quality which makes good art always fresh to us. These rank with the best American verse written up to that time. Nor do I know one of our elder or younger poets who might not be glad to have composed such an idyl as "Hylas" with its strong blank-verse made soft and liquid by feminine endings, the Dorian grace infused with just enough sentiment to make it effective in our modern times. It is worthy of a place in Landor's "Hellenics," and in my own mind always is associated with "Rhoecus." None of Taylor's later classical pieces is quite so good as this. There also are two charming oriental stories, in blank-verse,—a measure which he managed well,—"Kubleh" and "The Soldier and the Pard." "Ariel" and "Sorrowful Music," already mentioned, and the "Ode to Shelley," remind us too much of that poet, from whose weird and ethereal influence Taylor never quite freed himself, nor desired to free himself, until his dying day. These are fine poems, and so are others notably his own—"Sicilian Wine," "Taurus," "Serapion," and "The Metempsychosis of the Pine." The last-named lyric may be taken as a specimen of his characteristic mode. "We touch," he says, "the lower life of beast and clod:"

"All outward wisdom yields to that within,
Whereof no creed nor canon holds the key;
We only feel that we have ever been,
And ever more shall be.

"And thus I know, by memories unfurled
In rarer moods, and many a nameless sign,
That once in Time, and somewhere in the world,
I was a towering Pine,

"Rooted upon a cape that overhung
The entrance to a mountain gorge; whereon
The wintry shadow of a peak was flung
Long after rise of sun."

The poet informs the tree with conscious life. "When," he sings,

"Through all my fibres thrilled the tender sigh,
The sweet unrest of Spring.

"She, with warm fingers laced in mine, did melt
In fragrant balsam my reluctant blood;
And with a smart of keen delight I felt
The sap in every bud,

"And tingled through my rough old bark, and
fast
Pushed out the younger green, that smoothed
my tones,
When last year's needles to the wind I cast,
And shed my scaly cones."

Woodland, pastoral, and warlike scenes are pictured in compact stanzas, and memory recalls the rhythmic chant of the storm-swayed tree when it became "a harp for every wind, a voice for every sky." Music was its life. Nature's metempsychosis follows; the minstrel still feels the old life filling his brain with sweeps of song:

"And if some wild, full-gathered harmony
Rolls its unbroken music through my line,
There lives and murmurs, faintly though it be,
The Spirit of the Pine."

I have said that this volume contained the first fruits of an interval when the poet felt most keenly the compensations of art-life. And so it did; for it was by work like this that he was able to pass beneath and out from the shadow of a somber cloud. The painful romance of his youth; the lingering illness of the girl to whom he was betrothed, the marriage only a month before she died,—all this broke in upon precious days, and effected more than a temporary change. It was Taylor's nature not to take lightly such a loss, nor to hold loosely so tender a memory. His grief was foretold in the December lyric, "Moan, ye wild winds, around the pane!" It was the motive of a succession of memorial pieces, expressing moods of sorrow, that ended only years afterward, with the "vision" of "The Poet's Journal." But now it wore him down, sent him again on his wanderings, and determined that his life should become one of restless, varying action, rather than continue in this more creative repose.

His most extended journey began in 1851, shortly after the appearance of the "Romances." It led him up the Nile, over Syria, over Southern Egypt and Spain, finally to India, China, and the mystic islands of Japan; nor did he set foot in

New York again until midwinter, 1853-54. During this time he not only wrote the letters which made three volumes of prose, but had not failed to exercise his poetic skill. The main result was the "Poems of the Orient," which were collected in a book under that title in the ensuing year.

This work seems to me the high-water mark of his purely lyrical period, and may justly be characterized as original, vivid, spontaneous, harmonious in tone and artistic in execution. Of all the regions which Taylor now had traversed, the Orient seemed most nearly to touch his own nature. His ready adaptability to the life and sentiment of any land was surprising; he was our foremost type of the only being that can accommodate itself to all extremes of climate and custom. But he seemed to have been born for the Orient, and if his Songs do not set forth the East as orientals know it, they do set forth Taylor in the East:

"The Poet knew the Land of the East,—
His soul was native there."

It needed not Hicks's picture of the bronzed traveler, in his turban and Asiatic costume, smoking, cross-legged, upon a roof-top of Damascus, to show us how much of a Syrian he then was. We saw it in those down-drooping eyelids which made his profile like Tennyson's; in his aquiline nose, with the expressive tremor of the nostrils as he spoke; in his thinly tufted chin, his close-curling hair; his love of spices, music, coffee, colors and perfumes; his sensitiveness to out-door influences, to the freshness of the morning, the bath, the elemental touch of air and water and the life-giving sun. It is to be found in the "Poems of the Orient," where we have these traits reflected in diverse lyrics that make a fascinating whole. In them he seemed to give full vent to his flood of song. Whether from regard to the criticism that charged him with rhetoric and exuberance, or from the languor of work and travel, in after life his poetry often was more restrained, less fervid and exhilarating.

Among the Eastern poems, as now arranged after slight winnowing by the author, I find but one that is commonplace,—the "Nilotic Drinking-song," perhaps retained for its associations. Elsewhere the tone is well sustained, by turns glowing and languorous, usually rich in color and sound. The poet's intellect keeps him above the race he celebrates. A western Epicurean, he gets the best out of the East,—its finest passion

and wisdom and its changeless soul. A sonnet interprets Nubia, the land of dreams and sleep:

"Hush! for she does but sleep; she is not dead:
Action and Toil have made the world their own,
But she hath built an altar to Repose."

The varying skies of Egypt, the Desert, the Syrian Coast, of Damascus, of Persia, free these poems from the honeyed monotony of Moore's Orientalism, and the bookishness of Southey's. In manner, however, they sometimes remind us of Byron and of Hunt, and even of Tennyson, whose melodies have haunted so many singers, and whose "Maud" appeared in the same year with the lyrics before us. They are not of the latter-day fashion, either. Although more musical and refined in art than most work of a preceding date, their effects are obvious, their music and diction are subordinate to the main purpose. They thus lack the modern subtlety; but also avoid the fantastic word-handling of our latest verse, and are the more spontaneous and virile.

Here are some oriental tales in rhymed pentameter, and one in octosyllabic verse. "The Temptation of Hassan Ben Khaled" is the longest and best, the model of a narrative poem. William Morris has done nothing better of the kind. One wishes that Taylor had paid more attention to narrative poetry, availing himself, like Morris, of legends ready to his hand. He told a story in verse so easily and delightfully that he always underrated both the art and the poets who have excelled in it. "Amran's Wooing" is another good story—a tale of the Desert. Here also are songs, that will last as long as anything the poet wrote:

"Daughter of Egypt, veil thine eyes!"

and the almost unrivaled "Bedouin Song":

"From the Desert I come to thee
On a stallion shod with fire;
And the winds are left behind
In the speed of my desire.
Under thy window I stand,
And the midnight hears my cry:
I love thee, I love but thee,
With a love that shall not die
Till the sun grows cold,
And the stars are old,
And the leaves of the Judgment
Book unfold!"

There is a reminiscence of Shelley in one stanza; but this song has its own character and charm. The refrain is superb. Other

noteworthy pieces are, the "Ode to Indolence," a "Desert Hymn to the Sun," the apostrophe to Kilimandjaro, monarch of African mountains; poems like "The Goblet," "Aurum Potabile," "A Pledge to Hafiz," full of the spirit of the Persian Solomon; dithyrambic measures, also: "The Garden of Irem" and "Charmian," which suggests the field in which Taylor made so many excursions of late years. There is a faultless idyl in quatrains, celebrating the Hindoo legend of the coming of Camadeva, that would have delighted Sir William Jones, and which I always read with the same feeling that is derived from a poem as different on the surface as Collins's "Dirge in Cymbeline." It affords an exquisite instance of a quality which generally marks the "Poems of the Orient," that of *restraint*—the reserved strength which will not give one stroke too much. At last the poet folds his tent and unwinds the turban from his brow:

"The sun has ceased to shine; the palms that bent,
Inebriate with light, have disappeared;
And naught is left me of the Orient
But the tanned bosom and the unshorn beard."

There is a slight mannerism in these lyrics resulting from a vocabulary none too copious, and from the repetition of favorite images and rhymes. They are free from over-moralizing and show little of the influence of Longfellow, which at that time was so visible in American verse; they are poetry uttered for poetry's sake, from the heart that must have voice, and with the voice that sings independently.

A new edition was called for of Taylor's earlier poems. The best of them were reprinted in Boston as "Poems of Home and Travel," a title including also maturer pieces written for the magazines. Stoddard, Taylor, and others, were now engaged, with the elder poets, in supplying the verse which made attractive the first series of "Putnam's Magazine." This periodical was fortunate, like a successor, "The Atlantic,"—in its choir of songsters. Nor was it wanting in prose-poems, such as the delicate and haunting stories by the author of "Lotus-Eating," and the "Nile Notes of a Howadji." These books and Taylor's oriental poems were the complements of one another, and were as refreshing to the stay-at-home public that welcomed them as the Sicilian idyls of Theocritus and Bion once must have seemed to the desert-bordered citizens of Alexandria.

III.

THE poet-traveler was now in his thirtieth year. Assuming that his work now showed the quality of his gift, after the due period required for its development, we may pause to examine its value. If he never had done anything more, if his summons had come at this time,—there would have been, even as now, few whose taking-off would be so deplored, around whose memory would gather a more regretful interest. We should speak of the promise of a great career, and say, "Had he but lived!" and again, "A passing star; a shining track left upon the western skies!" He did live, and for years was a working man of letters, and must be judged by his product to the end. His life was consecrated to poetry yet not devoted to it. How much this means! Possibly he gained all the laurels he had a right to expect, under the conditions which he accepted. Had those conditions been otherwise I think he would have secured more. Circumstances and his own choice did not permit him to pay the price demanded for them. This was nothing less than the surrender of immediate honors; of twenty years of rare and eminent experiences, of growth in every direction. It would have been strange indeed if, at his age, he had not accepted "the good" the gods provided him,—trusting, through the aid of his strength and future occasion, to make even his half service of the muse as effective as the entire fealty of others who have won the crown.

Taylor had the elements of prolonged growth. Being what he was at thirty, the undisturbed practice of his art, a devotion like that of Tennyson's or Longfellow's, should have given him wide and indisputable poetic fame. By this course he would have refined that subtler sense which, as no one knows more surely than the present writer, is so elusive, so often dulled or stunted by the force, the outcry, the perturbing conflicts of the social, the trading, the professional, or even the patriotic and political, world of action and toil. Still, this poet's capabilities, aside from his gift of song, were unique, and pressed for employment. His memory was prodigious. Nothing that he learned was forgotten, and he learned without effort. After a single reading he knew a poem by heart, and could repeat whole pages of his favorite authors; and there was little that he did not read or see. His perception of externals was alert

and true; but he did not so readily catch by intuition the thoughts and feelings of those about him. He had a fine sense of form and color, drew and painted creditably, and seemed a natural artist. His linguistic powers were well known. He taught himself something of the classical texts, and was more infused with the antique sentiment than many a learned Theban. He quickly caught the pass-words and phrases of any language, Semitic or Aryan, wherever he journeyed. German he mastered, wrote in, thought in; it became so much like a native tongue with him as to refute the theory that one gains of a new language only so much as he loses of his own. His desire for knowledge was constant, and his professional training made him rapidly acquainted with the meaning and scope of a new work or movement that came within his view.

His personal traits were no less admirable. To think of him is to recall a person larger in make and magnanimity than the common sort; a man of indescribable buoyancy, hopefulness, sweetness of temper,—reverent, loyal, shrinking from contention yet ready to do battle for a principle or in the just cause of a friend; a patriot and lover of his kind, stainless in morals, and of an honesty so pure and simple that he could not be surprised into an untruth or the commission of a mean and unworthy act. His open delight over any work of his own that pleased him was the reverse of egotism, yet often misunderstood by those who slightly knew him. He was without jealousy, though sometimes ruffled by the prosperity of quacks and pretenders, and took as much pleasure in the legitimate success of others as in his own. Yet his personal ambition and aspiration were very great, only equaled by his heroic industry and scrupulous fulfillment of the lightest or heaviest task he undertook.

In social life he was generous and unrestrained, full of the knightly, mirth-loving, romantic spirit; a poet who kept his heart green to the last, even when disease was upon him, and the plethoric habit of his middle life. These dulled his eye, but never broke his spirit nor turned his thoughts to gall.

As a poet, we say, the qualities of his mature style were now fairly displayed. From the beginning, rhythm, the *susurrus* of liquid measures, had much to do with his sense of the beautiful in verse, and reacted upon his imagination. He reveled in the effect of the broad English vowels,

the "hollow ae's and oe's," and in the consonantal vigor of our language. He enjoyed reading aloud the poetry of Darley, of Byron and Shelley, and read his own with such melody and resonance, that one who listened to its chanting sound was no more able than himself to tell whether it was of his poorest or his best. Its dominant quality, therefore, was often that of eloquence, as in the verse of Croly and Campbell. Poe quoted from one of his early pieces, to show that eloquence and imagination may go together:

"Then, from her seat, amid the palms embowered
That shade the lion-land,
Swart Africa in dusky aspect towered,
The fetters on her hand.
Backward she saw, from out her drear eclipse
The mighty Theban years,
And the deep anguish of her mournful lips,
Interpreted her tears."

I have said that Bryant was "elemental" in his communion with sea and forest and the misty mountain winds. Taylor, as to the general range of his poetry, was ethnical and secular. Nations, races, eras, the past and future of mankind, were the objects of his regard; he got his material, his imaginative pictures, from their aspect, and his most elevated verse relates to their historic and prophetic phases.

His art-method was simple and direct, obvious rather than suggestive, and he generally composed in a major key. Some of his measures, like those of Barry Cornwall, are fresh with the breeze and spray:

"They were born by the shore, by the shore,
When the surf was loud and the sea-gull cried,
They were rocked to the rhythm of its roar,
They were cradled in the arms of the tide."

In other moods he would write a ballad, or a tender and exquisite lyric, like "The Song of the Camp," enough of itself to confirm his title as a poet. He had, in truth, the spontaneity of a born singer; but with it a facility that was dangerous indeed. His first draft was apt to be his best if not his only one. He had few affectations; his instinct being against obscurity and oddness of expression. The unstudied manner of the Georgian poets suited him, and he made his own verse as far as might be, the clear vehicle of his feeling. Of late years, in the desire to convey his deeper, more intellectual thought and conviction, he frequently became involved, and a metaphysical vagueness was apparent even in his lyrics. At such times the critics thought his efforts strained, and his friends declared that he was not working in his best vein.

HOW ANIMALS GET HOME.

ONE of the most striking powers possessed by animals is that of finding their way home from a great distance, and over a road with which they are supposed to be unacquainted. It has long been a question whether we are to attribute these remarkable performances to a purely intuitive perception by the animal of the direction and the practicable route to his home, or whether they are the results of a conscious study of the situation, and a definite carrying out of well-judged plans.

Probably the most prominent example of this wonderful power is the case of homing pigeons. These pigeons are very strong of wing, and their intelligence is cultivated to a high degree; for their peculiar "gift" has been made use of since "time whereof the memory of man runneth not to the contrary." The principle of heredity, therefore, now acts with much force; nevertheless, each young bird must be subjected to severe training in order to fit it for those arduous competitions which annually take place among first-rate birds. As soon as the fledgling is fairly strong on its wings, it is taken a few miles from the cote and released. It rises into the air, looks about it and starts straight away for home. There is no mystery about this at all,—when it has attained the height of a few yards the bird can see its cote, and full of that strong love of home which is so characteristic of its wild ancestors, the blue-rocks, it hastens back to the society of its mates. The next day the trial-distance is doubled, and the third day is still further increased, until in a few weeks it will return from a distance of seventy miles, which is all that a bird-of-the-year is "fit" to do; and when two years old, will return from 200 miles, longer distances being left to more mature birds. But all this training must be in a continuous direction; if the first lesson was toward the east, subsequent lessons must also be; nor can the added distance each time exceed a certain limit, for then, after trying this way and that, and failing to recognize any landmark, the bird will simply come back to where it was thrown up. Moreover, it must always be clear weather. Homing pigeons will make no attempt to start in a fog, or if they do get away, a hundred chances to one they will be lost. Nor do they travel at night, but settle down at dusk and renew their journey in the morn-

ing. When snow disguises the landscape, also, many pigeons go astray. None of these circumstances seriously hampers the semi-annual migrations of swallows or geese. Their journey at night, as well as by day, straight over vast bodies of water and flat deserts, true to the north or south. Homing pigeons fly northward or southward, east or west, equally well, and it is evident that their course is guided only by observation. Watch one tossed. On strong pinions it mounts straight up into the air a hundred feet. Then it begins to sweep around in great circles, rising higher and higher, until—if the locality is seventy-five or one hundred miles beyond where it has ever been before—it will go almost out of sight. Then suddenly you will see it strike off upon a straight course, and that course is homeward. But take the same bird there a second time and none of these aerial revolutions will occur,—its time is too pressing, its homesickness too intense for that; instantly it will turn its face toward its owner's dove-cote.

These facts mean something. They show that two definite intellectual processes serve to decide for the bird the direction he is to take,—observation and memory. He gets high enough, and turns about times enough, to catch sight of some familiar object, and he makes for it; arrived there, another known feature catches his eye, and thus by ever narrowing stages he is guided home. Few persons have any idea of the distance one can see at great elevations. More than once I have stood on peaks of the Rocky Mountains, where, had I been a pigeon, I could easily have steered my flight by another mountain fully 75 miles distant. Balloonists say that at the height of half a mile the whole course of the Thames or the Seine, from end to end, is spread out as plain as a map beneath their eyes. There is no doubt that a pigeon may rise to where he can recognize in clear weather a landscape 150 miles away; it has been done repeatedly, though only by the best birds, specially trained for that particular line of flight. There is no greater error than to suppose that carrier-pigeons sent a long distance from home in any direction will always return, as though attracted by a loadstone. The benevolent lady received only a good-natured laugh

for her pains, when she offered to equip the late British Arctic expedition with these winged messengers, who, she supposed, could be despatched from any point with tidings, and have a fair chance of getting straight back to England.

A pigeon's power of memory is really wonderful. Beginning with short stages, perhaps of not more than a dozen miles, the final stage of a match-flight of 500 miles will be more than 100. The country has been seen but once, yet the bird remembers it, and not only for the three or four days of a match, but for months. In June, 1877, birds trained from Bath to London were twice flown. On June 11th, of last year, they repeated the trip at good speed. Such feats are not uncommon with Belgian birds,—the best of all,—and there have been several authenticated instances of their going off-handed from England to Belgium after having been kept in confinement many months. But the homing intelligence of pigeons is subject to irregularity of action, and this very circumstance insists that it shall not be considered an unvarying, unreasoning instinct.

Enough has now been said, perhaps, to enable one to see that, however much the bird may be aided by an acute sense of direction,—a capability, I mean, of preserving a straight course, once ascertained, which sense some may prefer to speak of as an "instinct,"—the homing faculty of *le voyageur pigeon* is the result of education, and is not a matter of intuition at all.

The bee pursues a truly similar course. When he is loaded with nectar, you will note him cease humming about the heads of the flowers and spring up in a swift, vertical spiral, and after circling about a moment, shoot homeward "in a bee-line." Evidently he has "got his bearings." Had you watched him the first time he ever left his hive you would have observed precisely similar conduct, to acquaint himself with the surroundings.

How a bird like the albatross, the man-of-war-hawk, or the petrel, swinging on tireless pinions in apparently aimless flight over the tossing and objectless ocean, suddenly rouses its reserve of strength and traverses in a day or two the hundreds of miles between it and the rocky shores where it builds its nest; or how it finds the lone islet which these winged wanderers of the sea alone render populous, is not easily explained. Nor can we readily understand how once a year the salmon comes back

(from conjecture only guesses where)—not to the coast alone, for that would be no more than an ordinary case of migration, but to the identical stream where it was born; and to prove that it was not a blind emotion that led it, it would be harder than in the case of the pigeon, the bee, or even the frigate-bird. Yet who knows that the fishes may not be able to perceive the differences in the water which we designate "variations of temperature and density," or still more delicate properties, and thus distinguish the fluid of their native place from the outside element? It is a question, however, whether this phenomenon comes properly within the scope of this article.

Many domestic animals show a true homing faculty, and often in a degree which excites our surprise. One of the most remarkable cases I knew was that of two of the mules of a pack-train which, plainly by concerted action, left our camp one morning without cause or provocation. We were in south-western Wyoming, about seventy-five miles north-west of Rawlins Station, where we had begun our march. Our course, however, had been an exceedingly roundabout one, including a great deal of very bad country, where no road or trail existed. These mules made no attempt to trace it back, but struck straight across the country. They were chased many miles, and showed not the least hesitancy in choosing their way, keeping straight on across the rolling plain, with a haste which seems not to have been diminished until Rawlins was almost reached, when they were caught by some prospectors. For weeks they had to be kept carefully hobbled to prevent a repetition of the experiment.

How did these animals know the direction with such certainty? Mules frequently follow a very obscure trail backward for many miles, and, even more than horses, may be trusted to find the way home in the dark; but this is only when they have been over the road before, and is quite as fully due to their superior eyesight as to their strong sense of locality. I have also seen mules following the trail of a pack-train a few hours in advance, almost wholly by scenting; but the two runaways above had no other conceivable help in laying their course than some distant mountain-tops north and east of (and hence behind) them, and to profit by these would have required a sort of mental triangulation.

But the most common instances of hom-

ing ability are presented by our domestic pets, which often come back to us when we have parted with them, in a way quite unaccountable at first thought. An extremely instructive series of authentic examples of that excellent newspaper, the "London Field." The discussion was begun by a somewhat aggressive article by Mr. Tegetmeier, in which he expressed the opinion that most of such stories current were "nonsense," and cordially assigned to the regions of the fabulous those narratives which seemed to attribute this power to a special faculty possessed by the animal, instancing himself two cases where a dog and a cat found their way home, as he very justly supposes, by using their memories. The distance was not great; they obtained a knowledge of the routes and took their departure. "Very interesting," replied a correspondent, "but no argument against another cat or dog home-returning twenty or thirty miles across a strange district by means of instinct." And as evidence of his conclusion that "there is an attribute of animals, neither scent, sight, nor memory, which enables them to perform the home-returning journeys," this gentleman said:

"When I resided at Selhurst, on the Brighton and South Coast Railway, a friend living at Sutton gave me an Irish retriever bitch. She came over to him about a month previously from the county Limerick, where she was bred; and during her stay at Sutton she was on chain the whole time, with the exception of two walks my friend gave her in the direction of Cheam, which is in an opposite quarter to Selhurst from Sutton. She came to me per rail in a covered van, and the distance from home to home is about nine miles. She was out for exercise next morning, ran away, and turned up at her previous home the same afternoon."

But this proved to be a mild instance of such performances. A fox-hound was taken by train in a covered van forty miles from the kennels of one hunt to those of another in Ireland. The hound was tied up for a week, and then she was taken out with the pack. She hunted with them for the day, and returned in the evening to within a hundred yards of the kennel. "Here," relates the narrator, "I noticed her go into a field, sit down, and look about her. I called out to the young gentleman who hunts the hounds, whose way home was the same as mine: 'J., Precious is not going

on with you.' 'Oh, there's no fear of her,' was the reply. 'As she came so far, she will come the rest of the way.' So we went on to the kennel close by, but Precious did not appear, and we came back at once to the spot, sounded the horn, and searched everywhere. That was at six o'clock in the evening. On the following morning at six o'clock, when the messman went to the kennel door at Doneraile, Precious was there."

An officer took a pointer which certainly had never been in Ireland before, direct from Liverpool to Belfast, where he was kept for six months at the barracks. He was then sent by train and cart, in a dog-box thirty-four miles into the country, and tied up for three days. Being let out on the morning of the fourth, he at once ran away, and was found that same evening at the barracks at Belfast.

A sheep-dog was sent by rail and express wagon from Birmingham to Wolverton, but, escaping the next Saturday at noon, on Sunday morning appeared in Birmingham, having traveled sixty miles in twenty-four hours.

"Says one writer:

"I was stopping with a friend about eighteen miles from Orange, New South Wales. My host brought a half-grown kitten sixteen miles by a cross-bush track, tied in a flour-bag at the bottom of a buggy. She was fed that night; in the morning she had disappeared. She was home again in rather less than four days." The same person owned a horse in the interior of Australia, which, after two years of quiet residence on his run, suddenly departed, and was next heard of 100 miles away, at the run of the old master from whom it had been stolen years before.

A rough-coated cur was taken by a gentleman to whom he had been given from Manchester to Liverpool by train, thence to Bangor, North Wales, by steamboat; but on landing at Bangor the dog ran away, and the fourth day afterward, fatigued and foot-sore, was back in his home kennel, having undoubtedly traveled straight overland the whole distance. The same gentleman knew of a kitten that was carried in a covered basket six miles from one side of Manchester to the other, and found its way back the next day through the turbulent streets. Similarly, a fox-hound transported in a close box between points 150 miles distant, and part of the way through the city of London, came back as soon as let loose. A retriever bitch

did the same thing from Huddersfield to Stroud, a fortnight after being taken to the former place by rail; and a fox-hound returned from Kent to Northamptonshire, which are on opposite sides of the Thames; finally a dog came back to Liverpool from a distant point, whither he had been forwarded by rail *in the night*.

So many such instances are recorded that I refrain from mentioning more, except a couple of very illustrative ones which I find vouched for in the Rev. J. G. Wood's valuable little book, "Man and Beast." A mechanic who worked in Manchester but lived at Holywell, Wales, having been home on a visit, was given a dog to take back with him. "He led the animal from Holywell to Bagill by road, a distance of about two miles. Thence he took the market boat to Chester, a distance of about twelve miles, if I remember right. Then he walked through Chester, and took rail for Birkenhead. From that station he walked to the landing-stage, and crossed the Mersey to Liverpool. He then walked through Liverpool to the station in Lime street. Then he took rail to Manchester, and then had to walk a distance of a mile and a half to his home. This was on Wednesday. He tied the dog up, and went to his work on Thursday as usual; and on the Sunday following, thinking that the dog was accustomed to the place, he set it at liberty. He soon lost sight of it and on the Wednesday following, he received a letter from his mother, stating that the dog had returned to her. Now you will see that the dog went first by road, then by market-boat, then through streets, then by rail, then by steamer, then through streets again, then by rail again, then through streets again, it being dark at the time." Whether the animal really did follow the back-track with all this exactness or not, one thing is certain,—he had sagacity enough to find his way and (as is noteworthy in all these incidents) did so with astonishing speed.

The second instance is still more striking, and illustrates very forcibly the strong love of home in the dog, which is the motive in all these extraordinary and difficult journeys. "A gentleman in Calcutta wrote to a friend living near Inverkeithing, on the shores of the Frith of Forth, requesting him to send a good Scotch collie dog. This was done in due course, and the arrival of the dog was duly acknowledged. But the next mail brought accounts of the dog having disappeared, and that nothing could be

seen or heard of him. Imagine the astonishment of the gentleman in Inverkeithing when, a few weeks later, friend Collie bounced into his house, wagging his tail, barking furiously, and exhibiting, as only a dog can, his great joy at finding his master." Inquiry showed that the dog had come aboard a Dundee collier from a ship hailing from Calcutta.

Comparing all these examples and many others,—for hundreds, almost, of similar cases in various animals might be cited,—certain general facts appear.

First, incidentally, brutes equally with men become homesick. Those that stay away, as well as those that return to their former homes, show this very plainly and often pitifully. This feeling is the motive which leads them to undergo perils and hardships, that no other emotion would prompt them to undertake or enable them to endure. But it is the most thoroughly domesticated, and most intelligent breeds of animals that this homesickness attacks the most severely; while, correlatively, the most difficult feats of finding their way home are manifested by the same class. It is the finely bred horses, the carefully reared pigeons, the highly educated pointers, fox-hounds and collies, that return from the longest distances and over the greatest obstacles.

This would seem to indicate that the homing ability is largely the result of education; whatever foundation there may have been in the wild brute, it has been fostered under civilizing influences, until it has developed to an astonishing degree. I would like to ask any one who believes that this ability is wholly a matter of intuition,—an innate faculty,—why such an instinct should have been planted in the breast of animals like dogs and horses in their wild condition? They had no homes to which they could become attached as they do now in their artificial life, or when they did settle during the breeding season in any one spot, either they did not quit it at all, wandered only for a short distance, or else the females alone remained stationary, while the males roved as widely as usual. There would seem to be no call, therefore, for such an instinct in the wild animal. That they may always have had, and do now possess, a very acute sense of direction, enabling them to keep the points of the compass straight in their minds far better than we can, I am willing to admit; but I doubt whether the evidence proves a

nearer approach to a homing "instinct" than this. On the contrary, I believe, as I have already hinted, that beyond this, the performances of animals in the line of our inquiry are the result of accurate observation, and very retentive memory. That all these animals now and then do miss their bearings, get "turned around" and wholly lost, is true, and is a fact to be remembered in this discussion.

In the case of the birds, observation by sight is sufficient. They rise to a height whence they can detect a landmark, and flying thither, catch sight of another. The experience of pigeon-trainers shows this satisfactorily, and that of the falconers supports it. The far-reaching eyesight of birds is well known. Kill a goat on the Andes and in half an hour flocks of condors will be disputing over the remains, though when the shot was fired, not a single sable wing blotted the vast blue arch. The same is true of the vultures of the Himalayas and elsewhere. Gulls drop unerringly upon a morsel of food in the surf, and hawks pounce from enormous heights upon insignificant mice crouching in fancied security among the meadow stubble, while an Arctic owl will perceive a hare upon the snow (scarcely more white than himself) three times as far as the keenest-eyed Chippewa who ever trapped along Hudson's Bay. The eyesight, then, of pigeons and falcons is amply powerful to show them the way in a country they have seen before, even though the points they are acquainted with be a hundred miles apart.

In the cases of horses, dogs and cats, the explanation may be more difficult, and not always possible to arrive at. Horses and mules are extremely observant animals, and quick to remember places; everybody who has ever had anything to do with them must know this. Their recollection is astonishing. The Rev. J. G. Wood tells of a horse which knew its old master after sixteen years, though he had grown from a boy to a man and was, of course, much changed in both voice and appearance. It is probable that where horses come back, they do so mainly by sight and memory.

As for dogs, they not only can see well, but they have the additional help of their intelligent noses. The proficiency to which some breeds of dogs have brought their smelling powers—the precision with which they will analyze and detect different scents—is surprising. I have lately seen trustworthy accounts of two hunting-dogs, one

of which pointed a partridge on the further side of a stone wall, much to the surprise of his master, who thought his dog was an idiot; and the other similarly indicated a bird sitting in the midst of a decaying carcass, the effluvium of which was disgustingly strong, yet not sufficiently so to disguise the scent of the bird to the dog's delicate nostrils. Fox-hounds will trace for miles, at full speed and with heads high, the step of a Mercury-footed fox, simply by the faint odor with which his lightly touching pad has tainted the fallen leaves.

There are few cases where a dog is taken from one home to another, when he could not see most of the time where he was going. In that complicated journey of the Holywell workman's pet from northern Wales to Manchester, the little fellow had his eyes open the whole distance, we may be sure, and if he could speak he would no doubt tell us that he remembered his previous journey pretty well. But many times, especially where transported by rail, it is unquestionable that dogs rely upon their noses to get them back. Finding that they are being kidnapped, carried off from home and friends in this confined, alarming fashion, unable to see out of the tight box or the close car, they do just what you or I would under similar circumstances,—exert every possible means left them of discovering whether they are going, and take as many notes as possible of the route, intending to escape at the very first opportunity. One means of investigation remaining is the scent, and this they would use to great advantage, examining the different smells as their journey progressed, and stowing them away in their memory to be followed back in inverse order when they have a chance to return. Granting to these animals the discriminating sense of smell which experience shows to be possessed by them, I do not see any reason why they should not be able to remember a journey by its succession of odors just as well as they would by its successive landmarks to the eye. Even we, with our comparatively useless noses, can smell the sea from afar; can scent the sweetness of the green fields as well as the smokiness of black towns; and can distinguish these general and continuous odors from special or concentrated odors, which latter would change direction as the smeller changed position. How far this sense has really been developed in the human subject, perhaps few know; but in the history of Julia Brace, the deaf and

blind mute of Boston, for whom the late Doctor Howe accomplished so much, occurs a striking example. In her blindness and stillness, Julia's main occupation was the exercise of her remaining senses of touch, taste and smell. It was upon the last, we are told, that she seemed most to rely to obtain a knowledge of what was going on around her, and she came finally to perceive odors utterly insensible to other persons. When she met a person whom she had met before, she instantly recognized him by the odor of his hand or glove. If it was a stranger, she smelled his hand, and the impression remained so strong that she could recognize him long after by again smelling his hand, or even his glove, if he had just taken it off; and if, of half a dozen strangers each one should throw his glove into a hat, she would take one, smell it, then smell the hand of each person, and unerringly assign each glove to its owner. She would pick out the gloves of a brother and sister by the similarity of odor but could not distinguish between them. Similar cases might be produced, though hardly one of superior education in this respect; and in the light of it, it is not difficult to suppose that a sharp dog should be able to follow back a train of odors that he had experienced shortly before.

But there is another way by which anxious animals may learn their route both going and coming, and that is by listening and inquiring. It is remarkable how much of what is said by their masters all dogs understand. The books and periodicals of natural history and sport abound with illustrations of this, and one lately occurred within my own experience. A very good-natured and amusing, but utterly un-thoroughbred, little dog was a member of a family which I was visiting. The dog and I became very good friends at once, and remained so until the second day, when I casually began to joke his master upon owning such a miserable cur. At once the little dog pricked up his ears, and, noticing this, I continued my disparagements in a quiet, off-hand tone, his master meanwhile defending and condoling with him, until at last the dog could stand it no longer, but without any provocation beyond my language, which was not addressed to him at all, sprang up and softly bit at my heel, as though to give me warning of what might happen if the joke went any further; and after that he utterly broke off our friendship.

I mention this incident to call attention

to the alertness of our household pets in hearing and comprehending what is being said. Could not a dog on a railway remember the names of the towns through which he passed as they were called out by the attendants and spoken by travelers, and so be able to judge something of his way in return? The Rev. Mr. Wood suggested that the collie which returned from India was enabled to find the right vessel at Calcutta by hearing the well-known language and accent of the Scotch sailors; and again picked out from among many others the right collier in which to finish the journey, partly by remembrance of the rig, but also by recognizing the still more familiar and home-like dialect of the Dundee men. In a country where dialects are so marked as in Great Britain, this sort of observation would no doubt be of great help to an intelligent animal. Take the case of the Holywell workman's dog. It is quite possible that he discovered the right route from Liverpool, whither it would not be so difficult to make his way from Manchester, by following some rough-tongued Welshman until he found himself among his own hills again.

But there is still more to be said about this part of a homesick animal's resources and ingenuity. I am firm in my belief that animals have a language of signs and utterances by which they communicate with each other, and that their vocabulary, so to speak, is much larger than it has generally been considered to be. Dupont de Nemours declared that he understood fourteen words of the cat tongue. I am perfectly convinced that those two wicked little mules of ours, which ran away so disgracefully from our camp in Wyoming, had planned the whole thing out beforehand, and thus very likely had made up their minds as to the road. They had been bitter enemies, biting and kicking each other, contesting for coveted places in the line and quarreling the whole trip. But the evening before they ran away they were observed to be very amicable. It attracted our notice, and the last that was seen of them in the morning, just before they bolted, they stood apart from the rest with their heads together and their ears erect, waiting the right moment to dart away together. Tell a mountain mule-driver that the little beasts do not talk among themselves (chiefly in planning cunning mischief) and he will laugh in your face.

Cats, we know, consult a great deal together, and two street dogs often become

great cronies. Why should not these dogs and cats be able to tell stray companions something which should help them on their way? I believe they do—just how, I don't pretend to say.

It seems to me, therefore, that the examples cited above, and a host of others like them, show that all domestic animals have a very strong love of places and persons. In many cases this homesickness is so strong as to lead them to desert a new abode, when transferred to it, and attempt to return to their former home; but they *rarely or never do so without having a defi-*

nite idea in their minds as to the route, although it is often very long and circuitous, and hence they almost invariably succeed; *otherwise, they do not try.* In regard to the method used by them to find their way, it appears that they have no special instinct to guide them, but depend upon their memory of the route, the knowledge of which was acquired by an attentive study through the senses of sight, smell and hearing, possibly by communication with other animals. The phenomenon, as a whole, affords another very striking example of animal intelligence.

FOR A TRANSLATION OF THEOCRITUS.

O SINGER of the field and fold,
Theocritus! Pan's pipe was thine,—
Thine was the happier age of gold!

For thee the scent of new-turned mould,
The bee-hive, and the murmuring pine,
O singer of the field and fold!

Thou sang'st the simple feasts of old,—
The beechen bowl made glad with wine. . .
Thine was the happier age of gold!

Thou bad'st the rustic loves be told,—
Thou bad'st the tuneful reeds combine,
O singer of the field and fold!

And round thee, ever laughing, rolled
The blithe and blue Sicilian brine. . .
Thine was the happier age of gold!

To-day our songs are faint and cold,—
Our northern suns too sadly shine;
O singer of the field and fold,
Thine was the happier age of gold!

THE GRANDISSIMES.

A STORY OF CREOLE LIFE.

By GEORGE W. CABLE, author of "Old Creole Days."

CHAPTER I.

MASKED BATTERIES.

It was in the Theatre St. Philippe (they had laid a temporary floor over the parquette seats) in the city we now call New Orleans, in the month of September, and in the year 1803. Under the twinkle of numberless candles, and in a perfumed air thrilled with the wailing ecstasy of violins, the little Creole capital's proudest and best were offering up the first cool night of the languidly departing summer to the divine Terpsichore. For summer there, bear in mind, is a loitering gossip, that only begins to talk of leaving when September rises to go. It was like hustling her out, it is true, to give a select *bal masqué* at such a very early—such an amusingly early date; but it was fitting that something should be done for the sick and the destitute; and why not this? Everybody knows the Lord loveth a cheerful giver.

And so, to repeat, it was in the Theatre St. Philippe (the oldest, the first one), and, as may have been noticed, in the year in which the First Consul of France gave away Louisiana. Some might call it "sold." Old Agricola Fusilier in the rumbling pomp of his natural voice—for he had an hour ago forgotten that he was in mask and domino—called it "gave away." Not that he believed it had been done; for, look you, how could it be? The pretended treaty contained, for instance, no provision relative to the great family of Brahmin Mandarin Fusilier de Grandissime. It was evidently spurious.

Being bumped against, he moved a step or two aside, and was going on to denounce further the detestable rumor, when a masker—one of four who had just finished the contra-dance and were moving away in the column of promenaders—brought him smartly around with the salutation:

"Comment to ye, Citoyen Agricola!"

"H-you young kitten!" said the old man in a growling voice, and with the teased, half laugh of aged vanity as he bent a baffled scrutiny at the back-turned face of an ideal Indian Queen. It was not merely the *tutoiement* that struck him as saucy,

but the further familiarity of using the slave dialect.

"H-the cool rascal!" he added laughingly, and only half to himself; "get into the garb of your true sex, sir, h-and I will guess who you are!"

But the Queen, in the same feigned voice as before, retorted:

"*Ah! mo piti fils, to pas connais to zancestres?* Don't you know your ancestors, my little son?"

"H-the g-hods preserve us!" said Agricola, with a pompous laugh muffled under his mask, "the queen of the Tchoupitoulas I proudly acknowledge, and my great-grandfather, Epaminondas Fusilier, lieutenant of dragoons under Bienville; but,"—he laid his hand upon his heart, and bowed to the other two figures, whose smaller stature betrayed the gentler sex—"pardon me, ladies, neither Monks nor *Filles à la Cassette* grow on our family tree."

The four maskers at once turned their glance upon the old man in the domino; but if any retort was intended it gave way as the violins burst into an agony of laughter. The floor was immediately filled with waltzers and the four figures disappeared.

"I wonder," murmured Agricola to himself, "if that Dragoon can possibly be Honoré Grandissime."

Wherever those four maskers went there were cries of delight: "Ho, ho, ho! see there! here! there! a group of first colonists! One of Iberville's Dragoons! don't you remember great-great-grandfather Fusilier's portrait—the gilded casque and heron plumes? And that one behind in the fawn-skin leggings and shirt of bird's skins is an Indian Queen. As sure as sure can be, they are intended for Epaminondas and his wife, Lufki-Humma!"

"But why, then, does he not walk with her?"

"Why, because, Simplicity, both of them are men, while the little Monk on his arm is a lady, as you can see, and so is the masque that has the arm of the Indian Queen; look at their little hands."

In another part of the room the four were greeted with, "Ha, ha, ha! well, that is magnificent! But see that Huguenotte

Girl on the Indian Queen's arm! Isn't that fine! Ha, ha! she carries a little trunk. She is a *Fille à la Cassette!*"

Two partners in a cotillion were speaking in an undertone, behind a fan.

"And you think you know who it is?" asked one.

"Know?" replied the other. "Do I know I have a head on my shoulders? If that Dragoon is not our cousin Honoré Grandissime—well——"

"Honoré in mask? he is too sober-sided to do such a thing."

"I tell you it is he! Listen. Yesterday I heard Doctor Charlie Keene begging him to go, and telling him there were two ladies, strangers, newly arrived in the city, who would be there, and whom he wished him to meet. Depend upon it the Dragoon is Honoré, Lufki-Humma is Charlie Keene, and the Monk and the Huguenotte are those two ladies."

But all this is an outside view; let us draw nearer and see what chance may discover to us behind those four masks.

An hour has passed by. The dance goes on; hearts are beating, wit is flashing, eyes encounter eyes with the leveled lances of their beams, merriment and joy and sudden bright surprises thrill the breast, voices are throwing off disguise, and beauty's coy ear is bending with a venturesome docility; here love is baffled, there deceived, yonder takes prisoners and here surrenders. The very air seems to breathe, to sigh, to laugh, while the musicians, with disheveled locks, streaming brows and furious bows, strike, draw, drive, scatter from the anguished violins a never-ending rout of screaming harmonies. But the Monk and the Huguenotte are not on the floor. They are sitting where they have been left by their two companions, in one of the boxes of the theater, looking out upon the unwearied whirl and flash of gauze and light and color.

"Oh, *chérie, chérie,*" murmured the little lady in the Monk's disguise to her quieter companion, and speaking in the soft dialect of old Louisiana, "now you get a good idea of heaven!"

The *Fille à la Cassette* replied with a sudden turn of her masked face and a murmur of surprise and protest against this impiety. A low, merry laugh came out of the Monk's cowl, and the Huguenotte let her form sink a little in her chair with a gentle sigh.

"Ah, for shame, tired!" softly laughed the other; then suddenly, with her eyes fixed

across the room, she seized her companion's hand and pressed it tightly. "Do you not see it?" she whispered eagerly, "just by the door—the casque with the heron feathers. Ah, Clotilde, I *cannot* believe he is one of those Grandissimes!"

"Well," replied the Huguenotte, "Doctor Keene says he is not."

Doctor Charlie Keene, speaking from under the disguise of the Indian Queen, had indeed so said; but the Recording Angel, whom we understand to be particular about those things, had immediately made a memorandum of it to the debit of Doctor Keene's account.

"If I had believed that it was he," continued the whisperer, "I would have turned about and left him in the midst of the contra-dance!"

Behind them sat unmasked a well-aged pair, "*bredouille,*" as they used to say of the wall-flowers, with that look of blissful repose which marks the married and established Creole. The lady in monk's attire turned about in her chair and leaned back to laugh with these. The passing maskers looked that way, with a certain instinct that there was beauty under those two costumes. As they did so, they saw the *Fille à la Cassette* join in this over-shoulder conversation. A moment later, they saw the old gentleman protector and the *Fille à la Cassette* rising to the dance. And when presently the distant passers took a final backward glance, that same Lieutenant of Dragoons and the little Monk were once more upon the floor, waiting for the music.

"But your late companion?" said the voice in the cowl.

"My Indian Queen?" asked the Creole Epaminondas.

"Say, rather, your Medicine-Man," archly replied the Monk.

"In these times," responded the Cavalier, "a medicine-man cannot dance long without professional interruption, even when he dances for a charitable object. He has been called to two relapsed patients." The music struck up; the speaker addressed himself to the dance; but the lady did not respond.

"Do dragoons ever moralize?" she asked.

"They do more," replied her partner; "sometimes, when beauty's enjoyment of the ball is drawing toward its twilight, they catch its pleasant melancholy, and confess; will the good father sit in the confessional?"

The pair turned slowly about and moved toward the box from which they had come,

the lady remaining silent; but just as they were entering she half withdrew her arm from his, and, confronting him with a rich sparkle of the eyes within the immobile mask of the monk, said:

"Why should the conscience of one poor little monk carry all the frivolity of this ball? I have a right to dance, if I wish. I give you my word, Monsieur Dragoon, I dance only for the benefit of the sick and the destitute. It is you men—you dragoons and others—who will not help them without a compensation in this sort of nonsense. Why should we shrive you when you ought to burn?"

"Then lead us to the altar," said the Dragoon.

"Pardon, sir," she retorted, her words entangled with a musical, open-hearted laugh, "I am not going in that direction." She cast her glance around the ball-room. "As you say, it is the twilight of the ball; I am looking for the evening star,—that is, my little Huguenotte."

"Then you are well mated."

"How?"

"For you are Aurora."

The lady gave a displeased start.

"Sir!"

"Pardon," said the Cavalier, "if by accident I have hit upon your real name——"

She laughed again—a laugh which was as exultantly joyous as it was high-bred.

"Ah, my name? Oh no, indeed!" (More work for the Recording Angel.)

She turned to her protectress.

"Madame, I know you think we should be going home."

The senior lady replied in amiable speech, but with sleepy eyes, and the Monk began to lift and unfold a wrapping. As the Cavalier drew it into his own possession, and, agreeably to his gesture, the Monk and he sat down side by side, he said, in a low tone:

"One more laugh before we part."

"A monk cannot laugh for nothing."

"I will pay for it."

"But with nothing to laugh at?" The thought of laughing at nothing made her laugh a little on the spot.

"We will make something to laugh at," said the cavalier; "we will unmask to each other, and when we find each other first cousins, the laugh will come of itself."

"Ah! we *will* unmask—no! I have no cousins. I am certain we are strangers."

"Then we will laugh to think that I paid for the disappointment."

Much more of this child-like badinage fol-

lowed, and by and by they came around again to the same last statement. Another little laugh escaped from the cowl.

"You will pay? Let us see; how much will you give to the sick and destitute?"

"To see who it is I am laughing with, I will give whatever you ask."

"Two hundred and fifty dollars, cash, into the hands of the managers!"

"A bargain!"

The Monk laughed, and her chaperon opened her eyes and smiled apologetically. The Cavalier laughed, too, and said:

"Good! That was the laugh; now the unmasking."

"And you positively will give the money to the managers not later than to-morrow evening?"

"Not later. It shall be done without fail."

"Well, wait till I put on my wrappings; I must be ready to run."

This delightful nonsense was interrupted by the return of the *Fille à la Cassette* and her aged, but sprightly, escort, from a circuit of the floor. Madame again opened her eyes, and the four prepared to depart. The Dragoon helped the Monk to fortify herself against the outer air. She was ready before the others. There was a pause, a low laugh, a whispered "Now!" She looked upon an unmasked, noble countenance, lifted her own mask a little, and then a little more; and then shut it quickly down again upon a face whose beauty was more than even those fascinating graces had promised which Honoré Grandissime had fitly named the Morning; but it was a face he had never seen before.

"Hush!" she said, "the enemies of religion are watching us; the Huguenotte saw me. Adieu"—and they were gone.

M. Honoré Grandissime turned on his heel and very soon left the ball.

"Now, sir," thought he to himself, "we'll return to our senses."

"Now I'll put my feathers on again," says the plucked bird.

CHAPTER II.

THE FATE OF THE IMMIGRANT.

It was just a fortnight after the ball, that Joseph Frowenfeld opened his eyes upon Louisiana. He was an American by birth, rearing and sentiment, yet German enough through his parents, and the only son in a family consisting of father, mother, himself,

and two sisters, new-blown flowers of womanhood. It was an October dawn, when, long wearied of the ocean, and with bright anticipations of verdure, and fragrance, and tropical gorgeousness, this simple-hearted family awoke to find the bark that had borne them from their far northern home already entering upon the ascent of the Mississippi.

We may easily imagine the grave group, as they came up one by one from below, that morning of first disappointment, and stood (with a whirligig of jubilant mosquitoes spinning about each head) looking out across the waste, and seeing the sky and the marsh meet in the east, the north, and the west, and receiving with patient silence the father's suggestion that the hills would, no doubt, rise into view after a while.

"My children, we may turn this disappointment into a lesson; if the good people of this country could speak to us now, they might well ask us not to judge them or their land upon one or two hasty glances, or by the experiences of a few short days or weeks."

But no hills rose. However, by and by, they found solace in the appearance of distant forest, and in the afternoon they entered a land—but such a land! A land hung in mourning, darkened by gigantic cypresses, submerged; a land of reptiles, silence, shadow, decay.

"The captain told father, when we went to engage passage, that New Orleans was on high land," said the younger daughter, with a tremor in the voice, and ignoring the remonstrative touch of her sister.

"On high land?" said the captain, turning from the pilot; "well, so it is—higher than the swamp, but not higher than the river," and he checked a broadening smile.

But the Frowenfelds were not a family to complain. It was characteristic of them to recognize the bright as well as the solemn virtues, and to keep each other reminded of the duty of cheerfulness. A smile, starting from the quiet elder sister, went around the group, directed against the abstracted and somewhat rueful countenance of Joseph, whereat he turned with a better face, and said that what the Creator had pronounced very good they could hardly feel free to condemn. The old father was still more stout of heart.

"These mosquitoes, children, are thought by some to keep the air pure," he said.

"Better keep out of it after sunset," put in the captain.

After that day and night, the prospect

grew less repellent. A gradually matured conviction that New Orleans would not be found standing on stilts in the quagmire, enabled the eye to become educated to a better appreciation of the solemn landscape. Nor was the landscape always solemn. There were long openings, now and then, to right and left, of emerald-green savannah, with the dazzling blue of the Gulf far beyond, waving a thousand white-handed good-byes as the funereal swamps slowly shut out again the horizon. How sweet the soft breezes off the moist prairies! How weird, how very near, the crimson and green and black and yellow sunsets! How dream-like the land and the great, whispering river! The profound stillness and breadth reminded the old German, so he said, of that early time when the evenings and mornings were the first days of the half-built world. The barking of a dog in Fort Plaquemines seemed to come before its turn in the panorama of creation—before the earth was ready for the dog's master.

But he was assured that to live in those swamps was not entirely impossible to man—"if one may call a negro a man." Run-away slaves were not so rare in them as one—a lost hunter, for example—might wish. His informant was a new passenger, taken aboard at the fort. He spoke English.

"Yes, sir! Di' n' I 'ad to run from Bras Coupé in de haidge of de swamp be'ine de 'abitation of my cousin Honoré, one time? You can hask 'oo you like!" (A Creole always provides against incredulity.) At this point he digressed a moment: "You know my cousin, Honoré Grandissime, w'at give two 'on' fiftie dolla' to de 'ospill laz mont'? An' juz because my cousin Honoré give it, somebody helse give de semm. Fo' w'y don' 'e give 'is nemm?"

The reason (which this person did not know) was that the second donor was the first one over again, resolved that the little unknown Monk should not know whom she had baffled.

"Who was Bras Coupé?" the good German asked, in French.

The stranger sat upon the capstan, and, in the shadow of the cypress forest, where the vessel lay moored for a change of wind, told in a *patois* difficult, but not impossible, to understand, the story of a man who chose rather to be hunted like a wild beast among those awful labyrinths, than to be yoked and beaten like a tame one. Joseph, drawing near as the story was coming to a close, overheard the following English:

"Friend, if you dislike heated discussion, do not tell that to my son."

The nights were strangely beautiful. The immigrants almost consumed them on deck, the mother and daughters attending in silent delight while the father and son, facing south, rejoiced in learned recognition of stars and constellations hitherto known to them only on globes and charts.

"Yes, my dear son," said the father, in a moment of ecstatic admiration, "wherever man may go around this globe—however uninviting his lateral surroundings may be, the heavens are ever over his head, and I am glad to find the stars your favorite objects of study."

So passed the time as the vessel, hour by hour, now slowly pushed by the wind against the turbid current, now warping along the fragrant precincts of orange or magnolia groves or fields of sugar-cane, or moored by night in the deep shade of mighty willow-jungles, patiently crept toward the end of their pilgrimage; and in the length of time which would at present be consumed in making the whole journey from their Northern home to their Southern goal, accomplished the distance of ninety-eight miles, and found themselves before the little, hybrid city of "Nouvelle Orleans." There was the cathedral, and standing beside it, like Sancho beside Don Quixote, the squat hall of the Cabildo with the calabozo in the rear. There were the forts, the military bakery, the hospitals, the plaza, the Almonaster stores, and the busy rue Toulouse; and, for the rest of the town, a pleasant confusion of green tree-tops, red and gray roofs, and glimpses of white or yellow wall, spreading back a few hundred yards behind the cathedral, and tapering into a single rank of gardened and belvedere villas, that studded either horn of the river's crescent with a style of home than which there is probably nothing in the world more maternally home-like.

"And now," said the "captain," bidding the immigrants good-bye, "keep out of the sun and stay in after dark; you're not 'acclimated,' as they call it, you know, and the city is full of the fever."

Such were the Frowenfelds. Out of such a mold and into such a place came the young Américain, whom even Agricola Fusilier as we shall see, by and by thought worthy to be made an exception of, and honored with his recognition.

The family rented a two-story brick house in the rue Bienville, No. 17, it seems.

The third day after, at day-break, Joseph called his father to his bedside to say that he had had a chill, and was suffering such pains in his head and back that he would like to lie quiet until they passed off. The gentle father replied that it was undoubtedly best to do so and preserved an outward calm. He looked at his son's eyes; their pupils were contracted to tiny beads. He felt his pulse and his brow; there was no room for doubt; it was the dreaded scourge—the fever. We say, sometimes, of hearts that they sink like lead; it does not express the agony.

On the second day while the unsated fever was running through every vein and artery, like soldiery through the streets of a burning city, and far down in the caverns of the body the poison was ransacking every palpitating corner, the poor immigrant fell into a moment's sleep. But what of that? The enemy that moment had mounted to the brain. And then there happened to Joseph an experience rare to the sufferer by this disease, but not entirely unknown,—a delirium of mingled pleasures and distresses. He seemed to awake somewhere between heaven and earth, reclining in a gorgeous barge, which was draped in curtains of interwoven silver and silk, cushioned with rich stuffs of every beautiful dye, and perfumed *ad nauseam* with orange-leaf tea. The crew was a single old negress, whose head was wound about with a blue Madras handkerchief, and who stood at the prow, and by a singular rotary motion, rowed the barge with a tea-spoon. He could not get his head out of the hot sun; and the barge went continually round and round with a heavy, throbbing motion, in the regular beat of which certain spirits of the air—one of whom appeared to be a beautiful girl and another a small, red-haired man,—confronted each other with the continual call and response:

"Keep the bedclothes on him and the room shut tight, keep the bedclothes on him and the room shut tight,"—"An' don' give 'im some watta, an' don' give 'im some watta."

During what lapse of time—whether moments or days—this lasted, Joseph could not then know; but at last these things faded away, and there came to him a positive knowledge that he was on a sick-bed, where unless something could be done for him he should be dead in an hour. Then a spoon touched his lips, and a taste of brandy and water went all through him;

and when he fell into sweet slumber and awoke, and found the tea-spoon ready at his lips again, he had to lift a little the two hands lying before him on the coverlet to know that they were his—they were so wasted and yellow. He turned his eyes, and through the white gauze of the mosquito-bar saw, for an instant, a strange and beautiful young face; but the lids fell over his eyes, and when he raised them again the blue-turbaned black nurse was tucking the covering about his feet.

"Sister!"

No answer.

"Where is my mother?"

The negress shook her head.

He was too weak to speak again, but asked with his eyes so persistently, and so pleadingly, that by and by she gave him an audible answer. He tried hard to understand it, but could not, it being in these words:

"Li pa' oulé vini 'ci—li pas capabe."

Thrice a day for three days more, came a little man with a large head surrounded by short, red curls and with small freckles in a fine skin, and sat down by the bed with a word of good cheer and the air of a commander. At length they had something like an extended conversation.

"So you concluded not to die, eh? Yes, I'm the doctor—Doctor Keene. A young lady? What young lady? No, sir, there has been no young lady here. You're mistaken. Vagary of your fever. There has been no one here but this black girl and me. No, my dear fellow, your father and mother can't see you yet; you don't want them to catch the fever, do you? Good-bye. Do as your nurse tells you, and next week you may raise your head and shoulders a little; but if you don't mind her you'll have a back-set, and the devil himself wouldn't engage to cure you."

The patient had been sitting up a little at a time for several days, when at length the doctor came to pay a final call, "as a matter of form;" but, after a few pleasantries, he drew his chair up gravely, and, in a tender tone—need we say it? He had come to tell Joseph that his father, mother, sisters, all, were gone on a second—a longer—voyage, to shores where there could be no disappointments and no fevers, forever.

"And, Frowenfeld," he said, at the end of their long and painful talk, "if there is any blame attached to not letting you go with them, I think I can take part of it; but if you ever want a friend,—one who is

courteous to strangers and ill-mannered only to those he likes,—you can call for Charlie Keene. I'll drop in to see you, anyhow, from time to time, till you get stronger. I have taken a heap of trouble to keep you alive, and if you should relapse now and give us the slip, it would be a deal of good physic wasted; so keep in the house."

The polite neighbors who lifted their cocked hats to Joseph, as he spent a slow convalescence just within his open door, were not bound to know how or when he might have suffered. There were no "Howards" or "Y. M. C. A's" in those days; no "Peabody Reliefs." Even had the neighbors chosen to take cognizance of those bereavements, they were not so unusual as to fix upon him any extraordinary interest as an object of sight; and he was beginning most distressfully to realize that "great solitude" which the philosopher attributes to towns, when matters took a decided turn.

CHAPTER III.

"AND WHO IS MY NEIGHBOR?"

WE say matters took a turn; or, better, that Frowenfeld's interest in affairs received a new life. This had its beginning in Doctor Keene's making himself specially entertaining in an old-family-history way, with a view to keeping his patient within-doors for a safe period. He had conceived a great liking for Frowenfeld, and often, of an afternoon, would drift in to challenge him to a game of chess—a game, by the way, for which neither of them cared a farthing. The immigrant had learned its moves to gratify his father, and the doctor—well, the truth is, the doctor had never quite learned them; but he was one of those men who cannot easily consent to acknowledge a mere affection for one, least of all one of their own sex. It may safely be supposed, then, that the board often displayed an arrangement of pieces that would have bewildered Morphy himself.

"By the by, Frowenfeld," he said one evening, after the one preliminary move with which he invariably opened his game, "you haven't made the acquaintance of your pretty neighbors next door."

Frowenfeld knew of no specially pretty neighbors next door on either side—had noticed no ladies.

"Well, I will take you in to see them sometime." The doctor laughed a little, rubbing his face and his thin, red curls with one hand, as he laughed.

The convalescent wondered what there could be to laugh at.

"Who are they?" he inquired.

"Their name is De Grapion—oh, De Grapion, says I!—their name is Nancanou. They are, without exception, the finest women—the brightest, the best, and the bravest—that I know in New Orleans."

The doctor resumed a cigar which lay against the edge of the chess-board, found it extinguished, and proceeded to relight it. "Best blood of the Province; good as the Grandissimes. Blood is a great thing here, in certain odd ways," he went on. "Very curious sometimes." He stooped to the floor, where his coat had fallen, and took his handkerchief from a breast-pocket. "At a grand mask ball about two months ago, where I had a bewilderingly fine time with those ladies, the proudest old turkey in the theater was an old fellow whose Indian blood shows in his very behavior, and yet—ha, ha! I saw that same old man, at a quadron ball a few years ago, walk up to the handsomest, best dressed man in the house, a man with a skin whiter than his own,—a perfect gentleman as to looks and manners;—and without a word 'slap him in the face."

"You laugh?" asked Frowenfeld.

"Laugh? Why shouldn't I? The fellow had no business there. Those balls are not given to quadron *males*, my friend. He was lucky to get out alive, and that was about all he did."

"They are right!" the doctor persisted, in response to Frowenfeld's puzzled look. "The people here have got to be particular. However, that is not what we were talking about. Quadron balls are not to be mentioned in connection. Those ladies——" He addressed himself to the resuscitation of his cigar. "Singular people in this country," he resumed; but his cigar would not revive. He was a poor storyteller. To Frowenfeld—as it would have been to any one, except a Creole or the most thoroughly Creoleized American—his narrative, when it was done, was little more than a thick mist of strange names, places and events; yet there shone a light of romance upon it that filled it with color and populated it with phantoms. Frowenfeld's interest rose—was allured into this mist—and there was left befogged. As a physician, Doctor Keene thus accomplished his end,—the mental diversion of his late patient,—for in the midst of the mist Frowenfeld encountered and grappled a problem

of human life in Creole type, the possible correlations of whose quantities we shall presently find him revolving in a studious and sympathetic mind, as the poet of to-day ponders the

"Flower in the crannied wall."

The quantities in that problem were the ancestral—the maternal—roots of those two rival and hostile families whose descendants—some brave, others fair—we find unwittingly thrown together at the ball, and with whom we are shortly to have the honor of an unmasked acquaintance.

CHAPTER IV.

FAMILY TREES.

IN the year 1673, and in the royal hovel of a Tchoupitoulas village not far removed from that "Buffalo's Grazing-ground," now better known as New Orleans, was born Lufki-Humma, otherwise Red Clay. The mother of Red Clay was a princess by birth as well as by marriage. For the father, with that devotion to his people's interests, presumably common to rulers, had ten moons before ventured northward into the territory of the proud and exclusive Natchez nation, and had so prevailed with—so out-smoked—their "Great Sun," as to find himself, as he finally knocked the ashes from his successful calumet, possessor of a wife whose pedigree included a long line of royal mothers,—fathers being of little account in Natchez heraldry,—extending back beyond the Mexican origin of her nation, and disappearing only in the effulgence of her great original, the orb of day himself. As to Red Clay's paternal ancestry, we must content ourselves with the fact that the father was not only the diplomate we have already found him, but a chief of considerable eminence; that is to say, of seven feet stature.

It scarce need be said that when Lufki-Humma was born, the mother arose at once from her couch of skins, herself bore the infant to the neighboring bayou and bathed it—not for singularity, nor for independence, nor for vainglory, but only as one of the heart-curdling conventionalities which made up the experience of that most pitiful of holy things, an Indian mother.

Outside the lodge door sat and continued to sit, as she passed out, her master or hus-

band. His interest in the trivialities of the moment may be summed up in this, that he was as fully prepared as some men are in more civilized times and places to hold his queen to strict account for the sex of her offspring. Girls for the Natchez, if they preferred them, but the chief of the Tchoupitoulas wanted a son. She returned from the water, came near, sank upon her knees, laid the infant at his feet, and lo! a daughter.

Then she fell forward heavily upon her face. It may have been muscular exhaustion, it may have been the mere wind of her hasty-tempered matrimonial master's stone hatchet as it whiffed by her skull; an inquest now would be too grave an irony; but something blew out her "vile candle."

Among the squaws who came to offer the accustomed funeral howlings, and seize mementoes from the deceased lady's scant leavings, was one who had in her own palmetto hut an empty cradle scarcely cold, and therefore a necessity at her breast, if not a place in her heart, for the unfortunate Lufki-Humma; and thus it was that this little waif came to be tossed, a droll hypothesis of flesh, blood, nerve and brain, into the hands of wild nature with *carte blanche* as to the disposal of it. And now, since this was Agricola's most boasted ancestor—since it appears the darkness of her cheek had no effect to make him less white, or qualify his right to smite the fairest and most distant descendant of an African on the face, and since this proud station and right could not have sprung from the squalid surroundings of her birth, let us for a moment contemplate these crude materials.

As for the flesh, it was indeed only some of that "one flesh" of which we all are made; but the blood—to go into finer distinctions—the blood, as distinguished from the milk of her Alibamon foster-mother, was the blood of the royal caste of the great Toltec mother-race, which, before it yielded its Mexican splendors to the conquering Aztec, throned the jeweled and gold-laden Inca in the South, and sent the sacred fire of its temples into the North by the hand of the Natchez. For it is a short way of expressing the truth concerning Red Clay's tissues to say she had the blood of her mother and the nerve of her father, the nerve of the true North American Indian, and had it in its finest strength.

As to her infantine bones, they were

such as needed not to fail of straightness in the limbs, compactness in the body, smallness in hands and feet, and exceeding symmetry and comeliness throughout. Possibly between the two sides of the occipital profile there may have been an Incæan tendency to inequality; but if by any good fortune her impressible little cranium should escape the cradle-straps, the shapeliness that nature loves would soon appear. And this very fortune befell her. Her father's detestation of an infant that had not consulted his wishes as to sex, prompted a verbal decree which, among other prohibitions, forbade her skull the distortions that ambitious and fashionable Indian mothers delighted to produce upon their offspring.

And as to her brain: what can we say? The casket in which Nature sealed that brain, and in which Nature's great step-sister, Death, finally laid it away, has never fallen into the delighted fingers—and the remarkable fineness of its texture will never kindle admiration in the triumphant eyes—of those whose scientific hunger drives them to dig for *crania Americana*; nor yet will all their learned excavations ever draw forth one of those pale souvenirs of mortality with walls of shapelier contour or more delicate fineness, or an interior of more admirable spaciousness, than the fair council-chamber under whose dome the mind of Lufki-Humma used, about two centuries ago, to sit in frequent conclave with high thoughts.

"I have these facts," it was Agricola Fusilier's habit to say, "by family tradition; but you know, sir, h-tradition is much more authentic than history!"

Listening Crane, the tribal medicine-man, one day stepped softly into the lodge of the giant chief, sat down opposite him on a mat of plaited rushes, accepted a lighted calumet, and, after the silence of a decent hour, broken at length by the warrior's intimation that "the ear of Raging Buffalo listened for the voice of his brother," said, in effect, that if that ear would turn toward the village play-ground, it would catch a murmur like the pleasing sound of bees among the blossoms of the catalpa, albeit the catalpa was now dropping her leaves, for it was the moon of turkeys. No, it was the repressed laughter of squaws, wallowing with their young ones about the village pole, wondering at the Natchez-Tchoupitoulas child, whose eye was the eye of the panther, and whose words were the words of an aged chief in council.

There was more added; we record only enough to indicate the direction of Listening Crane's aim. The eye of Raging Buffalo was opened to see a vision: the daughter of the Natchez sitting in majesty, clothed in many-colored robes of shining feathers crossed and recrossed with girdles of serpent-skins and of wampum, her feet in quilled and painted moccasins, her head under a glory of plumes, the carpet of buffalo-robos about her throne covered with the trophies of conquest, and the atmosphere of her lodge blue with the smoke of ambassadors' calumets; and this extravagant dream the capricious chief at once resolved should eventually become reality. "Let her be taken to the village temple," he said to his prime-minister, "and be fed by warriors on the flesh of wolves."

The Listening Crane was a patient man; he was the "man that waits" of the old French proverb; all things came to him. He had waited for an opportunity to change his brother's mind, and it had come. Again, he waited for him to die; and, like Methuselah and others, he died. He had heard of a race more powerful than the Natchez—a white race; he waited for them; and when the year 1682 saw a humble "black gown" dragging and splashing his way, with La Salle and Tonti, through the swamps of Louisiana, holding forth the crucifix and backed by French carbines and Mohican tomahawks, among the marvels of that wilderness was found this: a child of nine sitting, and—with some unostentatious aid from her medicine-man—ruling; queen of her tribe and high-priestess of their temple. Fortified by the acumen and self-collected ambition of Listening Crane, confirmed in her regal title by the white man's Manitou through the medium of the "black gown," and inheriting her father's fear-compelling frown, she ruled with majesty and wisdom, sometimes a decreer of bloody justice, sometimes an Amazonian counselor of warriors, and at all times—year after year, until she had reached the perfect womanhood of twenty-six—a virgin queen.

On the 11th of March, 1699, two overbold young Frenchmen of M. D'Iberville's little exploring party tossed guns on shoulder, and ventured away from their canoes on the bank of the Mississippi into the wilderness. Two men they were whom an explorer would have been justified in hoarding up, rather than in letting out at such risks; a pair to lean on, noble and strong. They hunted, killed nothing, were overtaken

by rain, then by night, hunger, alarm, despair.

And when they had lain down to die, and had only succeeded in falling asleep, the Diana of the Tchoupitoulas, ranging the magnolia groves with bow and quiver, came upon them in all the poetry of their hope-forsaken strength and beauty, and fell sick of love. We say not whether with Zephyr Grandissime or Epaminondas Fusilier; that, for the time being, was her secret.

The two captives were made guests. Listening Crane rejoiced in them as representatives of the great gift-making race, and indulged himself in a dream of pipe-smokings, orations, treaties, presents and alliances, finding its climax in the marriage of his virgin queen to the king of France, and unvaryingly tending to the swiftly increasing aggrandizement of Listening Crane. They sat down to bear's meat, sagamite and beans. The queen sat down with them, clothed in her entire wardrobe: vest of swan's skin, with facings of purple and green from the neck of the mallard; petticoat of plaited hair, with embroideries of quills; leggings of fawn-skin; garters of wampum; black and green serpent-skin moccasins, that rested on pelts of tiger-cat and buffalo; armlets of gars' scales, necklaces of bears' claws and alligators' teeth, plaited tresses, plumes of raven and flamingo, wing of the pink curlew, and odors of bay and sassafras. Young men danced before them, blowing upon reeds, hooting, yelling, rattling beans in gourds and touching hands and feet. One day was like another, and the nights were made brilliant with flambeau dances and processions.

Some days later M. D'Iberville's canoe fleet, returning down the river found and took from the shore the two men, whom they had given up for dead, and with them, by her own request, the abdicating queen, who left behind her a crowd of weeping and howling squaws and warriors. Three canoes that put off in their wake, at a word from her, turned back; but one old man leaped into the water, swam after them a little way, and then unexpectedly sank. It was that cautious wader but inexperienced swimmer, the Listening Crane.

When the expedition reached Biloxi, there were two suitors for the hand of Agricola's great ancestress. Neither of them was Zephyr Grandissime. (Ah! the strong heads of those Grandissimes.)

They threw dice for her. Demosthenes

De Grapion—he who, tradition says, first hoisted the flag of France over the little fort—seemed to think he ought to have a chance, and being accorded it, cast an astonishingly high number; but Epaminondas cast a number higher by one (which Demosthenes never could quite understand), and got a wife who had loved him from first sight.

Thus, while the pilgrim fathers of the Mississippi Delta with Gallic recklessness were taking wives and moot-wives from the ill specimens of three races, arose, with the church's benediction, the royal house of the Fusiliers in Louisiana. But the true, main Grandissime stock, on which the Fusiliers did early, ever, and yet do, love to marry, has kept itself lily-white ever since France has loved lilies—as to marriage, that is; as to less responsible entanglements, why, of course —

After a little, the disappointed Demosthenes, with due ecclesiastical sanction, also took a most excellent wife, from the first cargo of House of Correction girls. Her biography, too, is as short as Methuselah's, or shorter; she died. Zephyr Grandissime married, still later, a lady of rank, a widow without children, sent from France to Biloxi under a *lettre de cachet*. Demosthenes De Grapion, himself an only son, left but one son, who also left but one. Yet they were prone to early marriages.

So also were the Grandissimes, or, as the name is signed in all the old notarial papers, the Brahmin Mandarin de Grandissimes. That was one thing that kept their many-stranded family line so free from knots and kinks. Once the leisurely Zephyr gave them a start, generation followed generation with a rapidity that kept the competing De Grapions incessantly exasperated, and new-made Grandissime fathers continually throwing themselves into the fond arms and upon the proud necks of congratulatory grandsires. Verily it seemed as though their family tree was a fig-tree; you could not look for blossoms on it, but there, instead, was the fruit full of seed. And with all their speed they were for the most part fine of stature, strong of limb and fair of face. The old nobility of their stock, including particularly the unnamed blood of her of the *lettre de cachet*, showed forth in a gracefulness of carriage, that almost identified a De Grandissime wherever you saw him, and in a transparency of flesh and classic beauty of feature, that made their daughters extra-marriageable in a land and day

which was bearing a wide reproach for a male celibacy not of the pious sort.

In a flock of Grandissimes might always be seen a Fusilier or two; fierce-eyed, strong-beaked, dark, heavy-taloned birds, who, if they could not sing, were of rich plumage, and could talk and bite, and strike, and keep up a ruffled crest and a self-exalting bad humor. They early learned one favorite cry, with which they greeted all strangers, crying the louder the more the endeavor was made to appease them: "Invaders! Invaders!"

There was a real pathos in the contrast offered to this family line by that other which sprang up as slenderly as a stalk of wild oats from the loins of Demosthenes De Grapion. A lone son following a lone son, and he another—it was sad to contemplate, in that colonial beginning of days, three generations of good, Gallic blood tripping jocosely along in attenuated Indian file. It made it no less pathetic to see that they were brilliant, gallant, much-loved, early epauletted fellows, who did not let twenty-one catch them without wives sealed with the authentic wedding kiss, nor allow twenty-two to find them without an heir. But they had a sad aptness for dying young. It was altogether supposable that they would have spread out broadly in the land; but they were such inveterate duelists, such brave Indian-fighters, such adventurous swamp-rangers, and such lively free-livers, that, however numerous their half-kin may have been scattered about in an unacknowledged way, the avowed name of De Grapion had become less and less frequent in lists where leading citizens subscribed their signatures, and was not to be seen in the list of managers of the late ball.

It is not at all certain that so hot a blood would not have boiled away entirely before the night of the *bal masqué*, but for an event which led to the union of that blood with a stream equally clear and ruddy, but of a milder vintage. This event fell out some fifty-two years after that cast of the dice which made the princess Lufki-Humma the mother of all the Fusiliers and of none of the De Grapions. Clotilde, the Casket-Girl, the little maid who would not marry, was one of an heroic sort, worth—the De Grapions maintained—whole swamps of Indian queens. And yet the portrait of this great ancestress, which served as a pattern to one who, at the ball, personated the long-deceased heroine *en masque*, is hopelessly lost in some garret. Those Creoles have such a shocking way

of filing their family relics and records in rat-holes.

One fact alone remains to be stated: that the De Grapions, try to spurn it as they would, never could quite suppress a hard feeling in face of the record, that from the two young men who, when lost in the horrors of Louisiana's swamps, had been esteemed as good as dead, and particularly from him who married at his leisure,—from Zephyr de Grandissime,—sprang there so many as the sands of the Mississippi for multitude.

CHAPTER V.

A MAIDEN WHO WILL NOT MARRY.

MIDWAY between the times of Lufki-Humma and those of her proud descendant, Agricola Fusilier, fifty-two years lying on either side, were the days of Pierre Rigaut, the magnificent, the "Grand Marquis," the Governor, De Vaudreuil. He was the Solomon of Louisiana. For splendor, however, not for wisdom. Those were the gala days of license, extravagance and pomp. He made paper money to be as the leaves of the forest for multitude; it was nothing accounted of in the days of the Grand Marquis. For Louis Quinze was king.

Clotilde, orphan of a murdered Huguenot, was one of sixty, the last royal allotment to Louisiana, of imported wives. The king's agents had inveigled her away from France with fair stories: "They will give you a quiet home with some lady of the colony. Have to marry?—not unless it pleases you. The king himself pays your passage and gives you a casket of clothes. Think of that these times, fillette; and passage free, withal, to—the garden of Eden, as you may call it—what more, say you, can a poor girl want? Without doubt, too, like a model colonist, you will accept a good husband and have a great many beautiful children, who will say with pride, 'Me, I am no House-of-Correction-girl stock; my mother'—or 'grand-mother,' as the case may be—'was a *fille à la cassette*!'"

The sixty were landed in New Orleans and given into the care of the Ursuline nuns; and, before many days had elapsed, fifty-nine soldiers of the king were well wived and ready to settle upon their riparian land-grants. The residuum in the nuns' hands was one stiff-necked little heretic, named, in part, Clotilde. They bore with her for sixty days, and then complained to

the Grand Marquis. But the Grand Marquis, with all his pomp, was gracious and kind-hearted, and loved his ease almost as much as his marchioness loved money. He bade them try her another month. They did so, and then returned with her; she would neither marry nor pray to Mary.

Here is the way they talked in New Orleans in those days. If you care to understand why Louisiana has grown up so out of joint, note the tone of those who governed her in the middle of the last century:

"What, my child," the Grand Marquis said, "you a *fille à la cassette*? France, for shame! Come here by my side. Will you take a little advice from an old soldier? It is in one word—submit. Whatever is inevitable, submit to it. If you want to live easy and sleep easy, do as other people do—submit. Consider submission in the present case; how easy, how comfortable, and how little it amounts to! A little hearing of mass, a little telling of beads, a little crossing of one's self—what is that? One need not believe in them. Don't shake your head. Take my example; look at me; all these things go in at this ear and out at this. Do king or clergy trouble me? Not at all. For how does the king in these matters of religion? I shall not even tell you, he is such a bad boy. Do you not know that all the *noblesse*, and all the *savants*, and especially all the archbishops and cardinals,—all, in a word, but such silly little chicks as yourself,—have found out that this religion business is a joke? Actually a joke, every whit; except, to be sure, this heresy phase; that is a joke they cannot take. Now, I wish you well, pretty child; so if you—eh?—truly, my pet, I fear we shall have to call you unreasonable. Stop; they can spare me here a moment; I will take you to the Marquise; she is in the next room. * * * Behold," said he, as he entered the presence of his marchioness, "the little maid who will not marry!"

The Marquise was as cold and hard-hearted as the Marquis was loose and kind; but we need not recount the slow tortures of the *fille à la cassette's* second verbal temptation. The colony had to have soldiers, she was given to understand, and the soldiers must have wives. "Why, I am a soldier's wife, myself!" said the gorgeously attired lady, laying her hand upon the governor-general's epaulet. She explained, further, that he was rather soft-hearted, while she was a business woman; also that the

royal commissary's rolls did not comprehend such a thing as a spinster, and—incidentally—that living by principle was rather out of fashion in the Province just then.

After she had offered much torment of this sort, a definite notion seemed to take her; she turned her lord by a touch of the elbow, and exchanged two or three business-like whispers with him at a window overlooking the Levee.

"Filleto," she said, returning, "you are going to live on the sea-coast. I am sending an aged lady there to gather the wax of the wild myrtle. This good soldier of mine buys it for our king at twelve livres the pound. Do you not know that women can make money? The place is not safe; but there are no safe places in Louisiana. There are no nuns to trouble you there; only a few Indians and soldiers. You and Madame will live together, quite to yourselves, and can pray as you like."

"And not marry a soldier," said the Grand Marquis.

"No," said the lady, "not if you can gather enough myrtle-berries to afford me a profit and you a living."

It was some thirty leagues or more eastward to the country of the Biloxis, a beautiful land of low, evergreen hills looking out across the pine-covered sand-keys of Mississippi Sound to the Gulf of Mexico. The northern shore of Biloxi Bay was rich in candleberry-myrtle. In Clotilde's day, though Biloxi was no longer the capital of the Mississippi Valley, the fort which D'Iberville had built in 1699, and the first timber of which is said to have been lifted by Zephyr Grandissime at one end and Epaminondas Fusilier at the other, was still there, making brave against the possible advent of corsairs, with a few old culverines and one wooden mortar.

And did the orphan, in despite of Indians and soldiers and wilderness, settle down here and make a moderate fortune? Alas, she never gathered a berry! When she—with the aged lady, her appointed companion in exile, the young commandant of the fort, in whose pinnace they had come, and two or three French sailors and Canadians—stepped out upon the white sand of Biloxi beach, she was bound with invisible fetters hand and foot, by that Olympian rogue of a boy, who likes no better prey than a little maiden who thinks she will never marry.

The officer's name was De Grapion—Georges De Grapion. The Grand Marquis gave him a choice grant of land on that part

of the Mississippi river "coast" known as the Cannes Brulées.

"Of course you know where Cannes Brulées is, don't you?" asked Doctor Keene of Joseph Frowenfeld.

"Yes," said Joseph, with a twinge of reminiscence that recalled the study of Louisiana on paper with his father and sisters.

There Georges De Grapion settled, with the laudable determination to make a fresh start against the mortifyingly numerous Grandissimes.

"My father's policy was every way bad," he said to his spouse; "it is useless, and probably wrong, this trying to thin them out by duels; we will try another plan. Thank you," he added, as she handed his coat back to him, with the shoulder-straps cut off. In pursuance of the new plan, Madame De Grapion,—the precious little heroine!—before the myrtles offered another crop of berries, bore him a boy not much smaller (saith tradition) than herself.

Only one thing qualified the father's elation. On that very day Numa Grandissime (Brahmin-Mandarin de Grandissime), a mere child, received from Governor De Vaudreuil a cadetship.

"Never mind, Messieurs Grandissime, go on with your tricks; we shall see! Ha! we shall see!"

"We shall see what?" asked a remote relative of that family. "Will Monsieur be so good as to explain himself?"

* * * * *

Bang! bang!

Alas, Madame De Grapion!

It may be recorded that no affair of honor in Louisiana ever left a braver little widow. When Joseph and his doctor pretended to play chess together, but little more than a half-century had elapsed since the *fille à la cassette* stood before the Grand Marquis and refused to wed. Yet she had been long gone into the skies, leaving a worthy example behind her in twenty years of beautiful widowhood. Her son, the heir and resident of the plantation at Cannes Brulées, at the age of—they do say—eighteen, had married a blithe and pretty lady of Franco-Spanish extraction, and, after a fair length of life divided between campaigning under the brilliant young Galvez and raising unremunerative indigo crops, had lately lain down to sleep, leaving only two descendants—females—how shall we describe them?—a

Monk and a *Fille à la Cassette*. It was very hard to have to go leaving his family name snuffed out and certain Grandissime-ward grievances burning.

CHAPTER VI.

LOST OPPORTUNITIES.

THE little doctor tipped his chair back against the wall, drew up his knees, and laughed whimperingly in his freckled hands.

"I had to do some prodigious lying at that ball. I didn't dare let the De Grapion ladies know they were in company with a Grandissime."

"I thought you said their name was Nancanou."

"Well, certainly—De Grapion-Nancanou. You see, that is one of their charms; one is a widow, the other is her daughter, and both as young and beautiful as Hebe. Ask Honoré Grandissime; he has seen the little widow; but then he don't know who she is. He will not ask me, and I will not tell him. Oh yes; it is about eighteen years now since old De Grapion—elegant, high-stepping old fellow—married her, then only sixteen years of age, to young Nancanou, an indigo-planter on the Fausse Rivière—the old bend, you know, behind Pointe Coupée. The young couple went there to live. I have been told they had one of the prettiest places in Louisiana. He was a man of cultivated tastes, educated in Paris, spoke English, was handsome (convivial, of course), and of perfectly pure blood. But there was one thing old De Grapion overlooked: both he and his son-in-law were the last of their names. In Louisiana a man needs kinfolk. He ought to have married his daughter into a strong house. They say that Numa Grandissime (Honoré's father) and he had patched up a peace between the two families that included even old Agricola, and that he could have married her to a Grandissime. However, he is supposed to have known what he was about.

"A matter of business called young Nancanou to New Orleans. He had no friends here; he was a Creole, but what part of his life had not been spent on his plantation he had passed in Europe. He could not leave his young girl of a wife alone in that exiled sort of plantation life, so he brought her and the child (a girl) down with him as far as to her father's place, left them there, and came on to the city alone.

"Now, what does the old man do but give

him a letter of introduction to old Agricole Fusilier! (His name is Agricola, but we shorten it to Agricole.) It seems that old De Grapion and Agricole had had the indiscretion to scrape up a mutually complimentary correspondence. And to Agricole the young man went.

"They became intimate at once, drank together, danced with the quadroons together, and got into as much mischief in three days as I ever did in a fortnight. So affairs went on until by and by they were gambling together. One night they were at the Piety Club, playing hard, and the planter lost his last quart. He became desperate, and did a thing I have known more than one planter to do: wrote his pledge for every arpent of his land and every slave on it, and staked that. Agricole refused to play. 'You shall play,' said Nancanou, and when the game was ended he said: 'Monsieur Agricola Fusilier, you cheated.' You see? Just as I have frequently been tempted to remark to my friend Mr. Frowenfeld.

"But, Frowenfeld, you must know, withal the Creoles are such gamblers, they never cheat; they play absolutely fair. So Agricole had to challenge the planter. He could not be blamed for that; there was no choice—oh, now, Frowenfeld, keep quiet! I tell you there was no choice. And the fellow was no coward. He sent Agricole a clear title to the real estate and slaves,—lacking only the wife's signature,—accepted the challenge and fell dead at the first fire.

"Stop, now, and let me finish. Agricole sat down and wrote to the widow that he did not wish to deprive her of her home, and that if she would state in writing her belief that the stakes had been won fairly, he would give back the whole estate, slaves and all; but that if she would not, he should feel compelled to retain it in vindication of his honor. Now wasn't that drawing a fine point?" The doctor laughed according to his habit, with his face down in his hands. "You see, he wanted to stand before all creation—the Creator did not make so much difference—in the most exquisitely proper light; so he puts the laws of humanity under his feet, and anoints himself from head to foot with Creole punctilio."

"Did she sign the paper?" asked Joseph.

"She? Wait till you know her! No, indeed; she had the true scorn. She and her father sent down another and a better title. Creole-like, they managed to bestir

themselves to that extent and there they stopped.

"And the airs with which they did it! They kept all their rage to themselves, and sent the polite word, that they were not acquainted with the merits of the case, that they were not disposed to make the long and arduous trip to the city and back, and that if M. Fusilier de Grandissime thought he could find any pleasure or profit in owning the place, he was welcome; that the widow of *his late friend* was not disposed to live on it, but would remain with her father at the paternal home at Cannes Brulée.

"Did you ever hear of a more perfect specimen of Creole pride? That is the way with all of them. Show me any Creole, or any number of Creoles, in a difficulty, and right down at the foundation of it all, I will find you this same preposterous, apathetic, fantastic, suicidal pride. It is as lethargic and ferocious as an alligator. That is why the Creole almost always is (or thinks he is) on the defensive. See these De Grapions' haughty good manners to old Agricole; yet there wasn't a Grandissime in Louisiana who could have set foot on the De Grapion lands but at the risk of his life.

"But I will finish the story; and here is the really sad part. Not many months ago, old De Grapion—'old,' said I; they don't grow old; I call him old—a few months ago he died. He must have left everything smothered in debt; for, like his race, he had

stuck to indigo because his father planted it, and it is a crop that has lost money steadily for years and years. His daughter and granddaughter were left like babes in the wood; and, to crown their disasters, have now made the grave mistake of coming to the city, where they find they haven't a friend—not one, sir! They called me in to prescribe for a trivial indisposition, shortly after their arrival; and I tell you, Frowenfeld, it made me shiver to see two such beautiful women in such a town as this without a male protector, and even"—the doctor lowered his voice—"without adequate support. The mother says they are perfectly comfortable; tells the old couple so who took them to the ball, and whose little girl is their music scholar; but you cannot believe a Creole on that subject, and I don't believe her. Would you like to make their acquaintance?"

Frowenfeld hesitated, disliking to say no to his friend, and then shook his head.

"After a while—at least not now, sir, if you please."

The doctor made a gesture of disappointment.

"Um-hum," he said grumly,—“the only man in New Orleans I would honor with an invitation!—but all right; I'll go alone.”

He laughed a little at himself, and left Frowenfeld, if ever he should desire it, to make the acquaintance of his pretty neighbors as best he could.

(To be continued.)

A SIGH.

I.

SOFT and low it stole on the silence of the night, distinct as a whisper; floating tremulously above the monotonous rush of the train and the breathing of sleeping passengers, as a bird floats over a swelling sea. Randolph Middleton, from his corner of the Italian railway-carriage, drew still lower his cap of brown seal-skin screening his face from the glare of the lamp in the roof, to dart a quick look of inquiry over its brim toward his *vis-à-vis*, a stout matron of forty, placid, rosy and fair; but her good-humored lips were smiling, even in sleep; her gently heaving breast rose and fell, unaided by sentiment or sigh; while the curly-pated

little fellow beside her nestled against the comfortable pillow of his mamma's plump shoulder, with undisturbed snores. Middleton's observant glance passed on to an amused study of a man's tightly closed mouth, surmounted by an aquiline nose; a brow ruffled by an invalid's fretfulness; a countenance distinguished, yet childish with petulance and pride. This gentleman was also soundly asleep, and hardly in a nightmare could have stooped to so tender a vent as a sigh, for either sorrow or joy.

Which of the two ladies, then, in the compartment next his own, had uttered that faltering cadence? Their dress told nothing but their sex; their ease of attitude, only

their station. The one nearest him was, indeed, unveiled; but her head was so turned, that only a profile of draped shoulder, and elbow, and knee, met the gaze of the baffled observer, who, vainly awaiting some movement or sound on which to fasten a conjecture, slowly resumed his attitude of repose.

Again, the soft zephyr of the melodious sigh fluttered forth over the silence, as a gauze-winged butterfly flutters over a quiescent flower. This time Middleton's cap fell from his hand to his knee, disclosing a handsome head; and so prompt was the look he turned on his fair neighbor, that it caught not only the sparkle of a jewel upon the finger, but also that of a tear-drop, slowly brushed from her cheek by an unglowed hand.

Deeply interested, Middleton slipped into the vacant seat beside him; as he did so, his hand grasped the arm of the division and was suddenly taken prisoner by the one he was inspecting, which came with a swift, nervous fall and settled palm downward upon the back of his own, clasping it even with a slight pressure, in the evident belief that its kidded breadth was but a tuft of the morocco-cushioned arm of a vacant seat.

Inexpressibly startled, he had yet the self-command not to stir a muscle of the imprisoned member, which might be released as suddenly and unconsciously as it had been captured. He scarcely dared breathe, lest, with the usual *mal apropos* of events, the face should turn toward him *now*, when he hoped it might not. But the head did not turn; and the white hand still lay clinging to his, as lightly as a snow-flake to the gray limb of a stalwart tree.

The nervous agitation of the long, slender fingers subsided into an occasional shiver, while transmitting a seductive thrill and tremor to his own rapidly increasing pulse; and he soon grew most uncomfortably happy (as men will) in the heightened action of his heart, the tumult of his veins, and in the uncalled-for disturbance which this pretty hand of an unknown woman could create in his breast. Gradually, the light clasp grew lighter, the head of bright hair sank back, and a measured breathing announced that whatever grief might have evoked the sighs was buried in the oblivion of sleep, leaving him to indefinite captivity, and the little hand to his keeping. He was fiercely beset with the temptation to make it prisoner in its turn, and it lay in his reversed palm before he could master the impulse to close his fingers around it.

The changed position brought a sense of right to control that which could, by so accidental a contact, flood his whole being with such serious emotion. His glance wandered from the round, tapering fingers to the blue veins traced under the exquisite skin, soft as eider-down, and a new temptation assailed him. How easily he could brush that smooth surface with the breath of a kiss! Would she awaken? Through that bold caress, might not something of his feeling pass into her dreams? He grew almost angry with the dainty little hand, unbidden but welcome guest of his own, destroying his peace while regaining its calm! Could he not compel it to share the emotion it caused? Was it so very unfair an advantage to take of this *distracted* lady, so unconsciously electrifying with her strange magnetism every nerve and fiber of his frame?

The gentleman in the opposite corner suddenly awoke; the linked hands disappeared under the convenient cap. With a petulant malediction on the slowness of these "miserable continental trains," he held his watch up to the light. From the cut of his clothes and his whiskers, his well developed frame and large amount of traveling paraphernalia, he was evidently an Englishman. He took a keen survey of Middleton, wound up his watch, and then transferred to his tongue, from a diminutive vial, several of those pigmy globules for which homeopaths claim miraculous powers. This ceremony restored his equanimity, and he maintained suspicious watch on the mysterious man who had resigned the coveted corner seat, aim (and attainment) of nearly every Englishman who enters a railway-carriage on the continent. The smooth current of the romance, concealed by Middleton's friendly cap, was checked. This sentinel had possibly some legitimate right to guard the little hand which, like Byron's "lone dove, without its mate," had flown down into his. Yes! such a dove possessed every species of guardianship,—father and brother to cage and caress it, brothers-in-law to patronize it, cousins to adore it; thank Heaven! the hand he held was the left, and no plain golden circlet enslaved the taper finger; at least, no brutal husband could drag it roughly from his! no stern necessity of honor or law command eternal separation! But a temporary parting he must accomplish, lest annoyance might reach her through this accident, so eventful for him!

During his episode with the aroused

Cerberus, a slight movement of the fair head had been followed by a gradual slipping of the soft fingers from his; he had ventured to check this with a gentle pressure, fearing the unconscious motion might displace the lightly poised cap, and thus provoke a climax more dramatic than comfortable. How was this to end? Was she never to learn the history of this hour? Had fate's caprice united them thus, only for the mockery of parting? He could not believe it. Every aim of his journey should be set aside to keep her in sight. At last the little hand, moved by slow stages, lay under her draperies. The crisis was past, and the cap was replaced on the head of its owner.

II.

MIDDLETON retraced his emotions with mingled relief and regret, until he also slept. When he awoke, the train had entered Milan. The little Italian was rubbing his black eyes with the backs of his brown fingers while his mother brushed up his thick curls; and the stately invalid was taking his morning dose of white globules. The two ladies were also awake, and their preparations for descending at the station were completed. Gloved and veiled, they sat motionless as statues, their books and other trifles gathered in their hands. She in whom he was most interested was taller than he had thought, and gazed haughtily away from every one, himself included, with a bearing strangely at variance with the memories of the night. Her companion was neither so tall nor so haughty, glancing toward him, as they glided under the echoing dome of the station, with a pretty, shy grace, much more suggestive of mute tears and eloquent sighs than was the proud mien of his queenly heroine. Still, Middleton could not trust his impressions; women are full of incongruities, he thought: the wariest student of their bewildering subtleties cannot always be safe from running against a paradox, or pitching headlong over the precipice of a surprise.

The guards passed rapidly along the carriages, unlocking and throwing open the doors, through which the passengers poured forth, in a tidal wave of hurrying humanity, as if the train had taken fire, and life would be the forfeit of delay. The *signora* and her *figlio* quitted the carriage with a sweet "*Addio, signors! Addio, signorine!*" to their fellow travelers, receiving from the ladies an *addio* as musical as their own. The arrival of the Englishman's valet and courier,

the one redolent of patchouli, the other of cigars, was the signal for their master's departure. His offers of service, "if he could be of any assistance," were calmly declined by the two tranquil forms, leaning back in their seats as if they intended to remain in them a day or two longer. Their "apartments were engaged," they said, their maid "attended to everything."

"I may call to-morrow?" he asked.

"Is it worth while, Sir John? We shall be out all day," answered one musical voice.

"We must see what we can of the city during our short stay," added the other musical voice,—the two so melodiously alike as to be quite undistinguishable. ("Sisters!" was Middleton's mental comment, busy with the straps of his portmanteau.) Sir John hoped that they "might meet in Florence;" but the ladies did not echo his wish. They "would see him in Rome," when they "would be again with mamma, who would be glad to receive him." So Sir John sauntered away, with a cool "good-morning!" (Mental comment the second,— "Without legal or natural right to scowl at me, after all; only an acquaintance! Are they school-girls going home to mamma? Impossible! too self-possessed! But they whisper, they rise.") The soft draperies swept past his knees before he ventured to look up at the two graceful figures, now standing irresolutely upon the platform. The approach of a smartly dressed, middle-aged lady's-maid, relieved their indecision. The maid held a Skye terrier clasped in her arms, on whom, with French volubility, she laid the blame of her delay.

"Your pardon, mesdemoiselles!" she cried; "it was Gypsy's talent for escaping that kept you waiting and unattended; but the carriage from the hotel is there, you have only to enter."

Slightly caressing the struggling pet, the ladies walked on. Too well-bred to glance back, they did not see Middleton accost the Frenchwoman, to ask whither Gypsy should be sent, "if one chanced to pick her up, during some future straying."

"Monsieur was so thoughtful," said the maid; "the case might well happen. Hotel de la Poste: *et mille remerciements,*" and she pocketed "monsieur's" gift.

But though Middleton passed the day and the following night under the roof of the Hotel de la Poste, neither his star nor her sister planet appeared in the firmament. He had, however, received no little infor-

mation as to the young ladies from Marie. "Monsieur had seen that Mademoiselle was beautiful as an angel, but ah, so proud, so haughty! *that* monsieur could not see. The other was *charmante*; but had been ill of fever, and had been ordered by the physician to remain at the baths, where Madame Fairfax, their mamma, had left the demoiselles Helen and Alice under Marie's care. Yes, monsieur was right; it was dangerous liberty; but *que voulez-vous? les mœurs Américaines!* Madame Fairfax was an American mamma, and her daughters must run their risks! They were on their way to Rome, where they would spend the winter. The young ladies were fatigued, and had dined in their *appartement* yesterday; to-day they would go out early." She wished, indeed, she could say at what hour they would be at the Duomo; but that was, alas! impossible. Our hero descended to the street, half-minded to turn back at the threshold, call for his bill, and resume his route for Paris. The fever of his exaltation, abated by twelve hours of daylight treatment, the opiate of a night's dreamless slumber, and the cooling draught of an evening at La Scala with friends, witty and mundane, was utterly subdued by the fly-bliſter applications of the Frenchwoman's shrugs and revelations. That his star-lit romance, possessing in its incipiency the intangibility of a dream, the refinement of accident, and the charm of mystery, should sink to the level of a wax-candle intrigue, lighted by the vulgar medium of gold pieces, was disillusion enough, though one of his own making; but to figure among the gas-jets of an American beauty's conquests, its illumination turned on for the attraction of other moths, was even more distasteful. Still, he directed his steps toward the great cathedral, deciding to give one look at the "angel face," now less an object of sentiment than of curiosity.

Mass was being celebrated at the grand altar when Middleton entered the cathedral, and he joined the assembled congregation, in respectful sympathy with a faith so nearly resembling his own. By the light tap of a subdued step, the rustle of silk, and a slight scrape on the pavement, he knew that some late-comer now filled the vacant *prie-dieu* beside him. In Roman Catholic churches it is not the custom to notice others during mass; so he did not look around. Then, through the devout silence following the rich harmonies of the *Gloria*, came straight to his ear the sigh—tremulous, beseeching,

pathetic—of his unforgotten experience. She was again beside him! Lost in wonder, as at the repetition of a forcible dream, he stole one look toward the fair head bent low, the face hidden by the round, slender fingers he had clasped, through which tears were now forcing their way; and the spell evoked by the careless touch of a woman's hand was renewed. The echoes of the *Dona nobis pacem* died away, the gorgeously robed priests and acolytes filed out of the sanctuary, the altar lights were extinguished, the worshipers dispersed. The lover stationed himself near the great tomb of St. Charles Borromeo; but she whom he expected to see pass unveiled before him still knelt in absorbed devotion. That type of man, dubbed by the great modern essayist a "world-philosopher," has one supreme weakness—the dread of being observed or made ridiculous; so the inquisitive glance of a tourist and the whispers of a group of young women, compelled Middleton to make a nonchalant circuit of the massive Borromeo tomb. When he returned to his post, the kneeling figure was gone. Looking around, he caught sight of the two ladies just entering the distant archway, leading to the statue-peopled roof of the Duomo, accompanied by Marie. He followed; but not till he was rapidly descending the steep, winding stair of the topmost spire (in some risk of flying through the wide apertures of its carved stone-work upon the heads of the people below) did he confront the beautiful face he so eagerly sought, uplifted to his and surprised into a frank smile by the sudden encounter; but his answering smile gave instant and evident offense, and she passed haughtily and disdainfully on with the guide. "American beauty and belle, every inch of her!" was his discomfited comment. "Would any other civilized woman exact the right to resent with her frown the response she called forth by her smile?" and rapidly descending, he passed without a glance her sister, resting on a bench at the foot of the tower, with Marie at her side.

Middleton had once for all decided that the whole affair was a folly which should end there, when the Frenchwoman's rapid step overtook him, and her staccato accents explained that Mademoiselle had grown dizzy in descending the spire; would monsieur advise? Their guide could do nothing! Mademoiselle Helen was always self-willed, and now she would not move!

Not sorry to look again on the exquisite face, though with a little good-natured

malice in his heart at this downfall to such loftiness, Middleton remounted the stair and stood beside the scornful beauty with a pulse as calm as her own. She was seated on the steps, just at the turn where they had met so suddenly; one hand grasped the stone balustrade, the other covered her eyes. The guide gladly made way for the new-comer, who asked, in a cool tone of indifference, if he could assist her, and if she was faint.

"Not in the least," was the reply.

"Then your nerve fails; you tremble, do you not?—fearing to fall headlong?"

"How do you know?" and the violet eyes opened with surprise.

"Through much Alpine experience. Will you choose now from three alternatives, in lieu of my aid?"

"What are they?" The beautiful eyes looked away from him with a *distrain* expression.

"The first is to remain where you are, to be remarked on, perhaps trampled on, by climbing tourists, till a restorative is obtained from the city beneath us. The second is really too undignified to be suggested to so"—

The speaker paused.

"Oh! pray go on; let me hear them all."

"To descend backward (though you need not look over your shoulder) like a cat or a bear. The last you will think even worse, I fancy: To be *carried* down, without your leave, by the guide and myself."

A charming smile fairly illuminated her face, and a faint blush gave that tinge of feeling its loveliness needed, as she placed her gloved finger-tips in the hands courtously held out to assist her to rise.

"Keep your eyes steadfastly on mine," Middleton directed, as stepping carefully backward, his eyes raised to hers, he watched the blush fade from her cheek, and the smile die on her lips. Then all the proud reserve of her manner and look returned in full force. Quietly withdrawing from his support, she murmured

"Thank you; you are very kind; there is no further need to detain you."

Although Middleton rather plumed himself upon his knowledge of the world and of women, he could not quite master his surprise at this summary dismissal, which, though it amused him a little, piqued him much more, and he left her with a bow as cool as her own. When he emerged a second time upon the broad roof, he had leisure to notice that her sister Alice had withdrawn some distance from the tower,

as if to keep out of his way; but this may have been only his fancy.

III.

MIDDLETON arose the next morning unrefreshed, though in a more decided frame of mind with regard to his graceful adventure. Certainly, he could not accept the poor figure he had cut in yesterday's *rencontre* as his exit from a stage upon which he had made so exciting a *début*. This thought, combined with a new interest he had formed for his dethroned heroine, settled him in the resolve to resign all idea of Paris; to take, instead, whichever train these young women might take for Florence, and even to go on to Rome. No longer of an age to contemplate that delight of inexperienced youth, a pursuit which should, in its final conquest, place this contemptuous beauty in his hands, for mercy or revenge; nor yet old enough to practice that indifference with which men past maturity punish feminine insensibility to their time-worn fascinations, he had stepped into the pitfall prepared for the mature philosopher, whose still youthful heart yet retains sensibility. This incomprehensible damsel was not to be worshiped as Love's fixed-star of hope, nor to be followed into the quagmire of disappointment as the bright *ignis fatuus* of disillusion, but to be studied as a curious meteor, with the telescope of philosophical analysis.

But while he had been uncomfortably dreaming of a leap from the spire of the cathedral with the wrong sister clasped to his heart, the sisters themselves were steaming safely away from him and his dreams, on the early morning train for Florence. There was nothing left but to follow, and to spend a day going the rounds of the hotels bordering the Arno, in ostensible search for an *appartement*; in reality for some trace of the Misses Fairfax, for whom his natural delicacy forbade him to make open inquiry, even had not the laws regulating continental etiquette required this caution.

His search was fruitless, and ended in the conviction that his wisest course was to trust to the chance of some more conventional meeting in the Roman city, rather than to these accidents of the highways, which, however romantic, were far from satisfactory. Two or three days in the Medicean city gave him time for his usual visits to the galleries, and he took a daylight train for Rome.

By a coincidence frequent in life, though unnatural in a novel, he had scarcely secured his corner for the journey to Rome when the guard ushered up to the door of the carriage the Misses Fairfax. For once, these extremely tranquil young persons were in a flutter, and much too preoccupied with Gypsy's well-being in the basket provided for her concealment to bestow a thought on the solitary figure whose head was so thrust out of the opposite window that not even a back view of it was possible. Marie was flustered and cross; they had come so near missing their train. Gypsy was rebellious; to smuggle live-stock in a lunch-basket is a grave undertaking. The queenly Helen's murmur, "Gypsy! lie still!" availed little against the terrier's necessity for fresh air. The quaint little muzzle would peep from the lid of its prison; two soft-haired gray paws would stretch over its edge, and the round, shining eyes looked plaintively forth from their steel-colored frizz in pathetic remonstrance, till, lulled by the rumble of the train, they closed in sleep. The fair guardians now resumed their usual traveling pose of indifference to their surroundings,—their inattentive eyes wandering from the books carelessly held in their gloved fingers to the landscape, but never for a moment resting on their fellow-passengers, whose interest in these young ladies was baffled by the thick folds of blue gauze shrouding their faces,—that feminine penance which only American and Oriental vanity and lungs seem able to endure. Middleton began to think that the sisters might possibly reach Rome without ever discovering him. But Gypsy prepared a most piquant climax and introduction, far surpassing in result any that he could have invented for himself.

They had reached a station within a few hours of Rome; Marie had brought her tired mistresses coffee and a few cakes from the *buffet*; and had then returned to her place *au seconde*. The presence of cake, or the stopping of the train, threw the animated lunch-basket into an internal convulsion, which sent it bouncing through the still unclosed door, and down under the wheels of the carriages; and the liberated prisoner scampered off up the platform. The soft cry of distress from the ladies was simultaneous with Middleton's leap to the rescue, which was followed by the bang of the closing doors of the carriages and the sharp whistle in signal for starting. As the train glided off, he ran alongside the carriage

for a moment, with his hand on the door, and with a smiling request for their little dog's address "when in Rome." It was eagerly and unblushingly given, "Fairfax, Hôtel de Russie." The ladies' protection for his portmanteau was hastily requested and promised, with inarticulate thanks, as the train tore away from his hold.

Gypsy scudded about in swift whirls of excitement, with sharp little barks of delight; and her newly appointed guardian had ludicrous difficulty in capturing his troublesome ward. Provided with a pocket edition of a favorite author, he cheerfully awaited the next train for Rome. With no little masculine satisfaction, his fancy depicted the Misses Fairfax deploring the inconvenience he had incurred in their service.

These ladies, however, were making a better use of their time. The few way-passengers had left the carriage at an intermediate station, and they had it to themselves for a while.

"How odd," observed Alice, removing her veil, "to have charge of this stranger's luggage!"

"And to sit staring at this portmanteau," exclaimed Helen, "as if it could bite, or go off like a pistol."

"I suppose there's no harm in reading over those labels," continued Alice, kneeling beside the portmanteau. "He has really been *everywhere*: Cairo and Athens, Constantinople, Jerusalem, and Rome, quite recently; then St. Petersburg—a long time back; do you think he is Russian?"

"No; his English is hardly precise enough. I wish I could compliment him, and exasperate Sir John, by mistaking him for an Englishman,—compliment dear to every American heart; for, do you know, though by his eyes, he might be Italian, and by his beard, the Grand Turk, I suspect him to be only an American, after all," answered Helen, laughing aloud.

"That would be very disappointing," murmured Alice; "he looks so unlike. Ah! here are initials—G. R. M."

Helen languidly rose, and bending over her sister, lifted the tall hat from the netting above.

"Since no one is here, and he never can know," she said, with a roguish smile. "It is so very exasperating to have only a pronoun for a man's title!"

A subdued little laugh broke from Alice.

"You hold it as if it were an adder."

"Who likes to touch a man's hat?" replied Helen; "but a name tells so much, I *must* know it!"

Both young faces peered into the hat; and the two soft voices read

"*George Randolph Middleton.*"

"American! I said so," said Helen; replacing the hat in the netting. "The idea of our having to take care of this hat; how provoking! What shall we do when we reach Rome?"

Alice suggested that Marie would be only too happy to look after its safety, "since this Mr. Middleton was having trouble with Gypsy." The train had stopped at a station; the door was thrown back by the guard, and a gentleman passing by stepped up to the ladies, lifted his hat, and expressed great pleasure at finding them on the train; there was so much "room in their carriage," he would have "his traps moved into it at once;" and soon they were journeying to Rome, as they had journeyed to Milan, with Sir John Farleigh opposite, conversing agreeably and being specially witty at the expense of the supposed loser of the ownerless hat. To this the young ladies replied only with smiles; and when, at the end of their journey, he saw Marie directed to take "particular care" of the forsaken hat; and to "send up that portmanteau" with their luggage to the hotel, Sir John felt a shock of consternation. The young ladies vouchsafed no explanation, and he drove off to his hotel much scandalized.

IV.

IN a window-recess of the *salon* of the Fairfax family in the Hôtel de Russie (the day after their arrival in Rome), stood Sir John Farleigh, an edified witness of a struggle for American independence of maternal authority.

Miss Helen Fairfax had laid on the table by which Alice was seated, a visitor's card, and her sister's eyes rested on the engraved name of "Mr. G. Randolph Middleton," beneath which was written in pencil "Miss Gypsy." Mrs. Fairfax, enthroned in a commanding attitude on the sofa near the fire, lifted a detaining forefinger for the valet, whose hand still held the door-knob, while she pointed with the other to the tall folding-doors through which her daughters were to vanish before this stranger could be admitted to her presence. She was handsome and dignified, yet so youthful in appearance that her daughters seemed almost justified in their rebellion. But their mamma was in the right, and they were obliged to yield. Alice rose, with a cloud in her eyes, and gravely

walked out of the room. Helen with a frown on her fair face (quite as much for Sir John as for her mother) reluctantly followed. Mrs. Fairfax remained mistress of the field, but she found the victory more unmanageable than the struggle. Sir John came to her relief, offering to receive this embarrassing stranger, who had intruded an obligation upon her, yet could not be accepted as visitor or acquaintance without credentials of some kind. A sister of Mrs. Fairfax, it seems, had married an Englishman of rank, a near neighbor of Sir John's; at this brother-in-law's home, the Fairfax family had first known the baronet, whose fine estate and large fortune added greatly to his standing in English society; and now that he had been spending a part of the autumn at the baths of Lucca, in close and frequent attendance upon these ladies, he ventured to claim the position almost of friend. Mrs. Fairfax readily consented to Sir John's proposal, and her stately form passed out of the *salon* as her visitor was ushered over the threshold of the anteroom, with Gypsy, contented and subdued, at his heels.

The English baronet received Mr. Middleton without the dawning of a recollection of their having met not eight days before, on the train between Como and Milan. The freemasonry of good breeding enabled him, however, to recognize at once the man of good society and position, and he introduced himself courteously by name before entering upon the matter of the little animal's capture and surrender. Very certainly, had the ladies remained in the room, the captious and jealous baronet would have been far less amiable.

The low murmuring of their undertoned voices in continued conversation irritated the secluded fair ones in the adjoining chamber into a high-tide of American insubordination.

"He must think us so ungracious—so commonplace!" murmured Alice, leaning her dejected head against the tall mantel.

"What has Sir John Farleigh to do with it?" asked Helen of the painted ceiling, to which she lifted her indignant eyes. "The idea!—as if he was a member of the family! It is so disagreeable."

"What do regular introductions matter," continued Alice, raising her head, "when one sees and *knows* a man to be a gentleman?"

"How could you see? You never looked at him," answered Helen, bringing her pretty head down to a level with the look-

ing-glass before which she was sitting, and from which her eyes sought consolation. "How could you *know*? Mr. Middleton noticed Marie, or Gypsy, more than he did you! Still, if he is not a gentleman, he is a very good counterfeit. His name is a little too fine, I admit. Is that his card in your hand? Let us see how it looks stuck up in the mirror, beside these half dozen aristocrats. Ah! pretty well; unassuming and truly American, with that absurd initial our countrymen are so fond of—do you know, the hotel people here think it stands for some grand title!"

"Listen!" said Alice, "they are ringing the bell. Marie is sent for, I suppose. How Gypsy is barking!"

"Of course," laughed Helen, in recovered good humor, "she *hates* Sir John Farleigh. Shall we surprise them with a *coup d'état*—walk in and get Gypsy?"

"Oh no!" said the more conservative Alice, drawing her sister back from the door. "I wonder he stays so long!"

"So do I," answered Helen, "with no one but that prosy Sir John to entertain him. Marie, come in! Now, what is it?"

The lady's-maid was closing the door behind her with a mysterious excitement that needed no second bidding to break forth with the summons to the young ladies from *madame mère*, to return with madame to the *salon*; Sir John Farleigh wished to present Mr. Middleton as the brother of an old college friend of Sir John's; Marie "believed" (which meant she had listened) that Sir John said he considered it "an agreeable duty," and was much delighted to have a letter from "his old Oxford comrade," introducing this younger brother to Sir John as the writer's "superior in everything but age"—the very words of the letter, for Sir John read it aloud!

This great news was received with a calmness and reserve exasperating to the Frenchwoman's feelings, Helen only observing that "so prosaic an ending deprived the man of all interest."

Though to Helen Mr. Middleton's formal presentation was "a prosaic ending," to him it was an eventful ceremony. Mrs. Fairfax placed a hand within his, and after her Helen, and then Alice. Whose hand was this? *Hers!*—yet this was not *she!* The pretty hand trembled, the soft gray eyes fell, and the fair cheek crimsoned under the enlightened eyes bent on the face, now first unveiled to their gaze.

"What an inexplicable mistake to have

made! Where had it begun? Does *she* know that she blushes so deeply?" spoke his thoughts in his eyes, as their hands slowly parted. "You will find Gypsy quite well," spoke his words through his lips. Then was formed that oppressive circle, that formidable council of war, with which English and American people stultify visitors, making it equally awkward to be consciously stupid or conspicuously bright; the result—pointless remarks, silent intervals, leading questions, silly answers. Neither Mrs. Fairfax nor her daughters possessed the usual glib tongue of their countrywomen. Their new acquaintance also grew strangely silent, leaving the languid Sir John to shine as the life of the conversation.

In answer to questions, Middleton confessed himself of many countries and climes. His father, when a widower, turned his back on America, on his native state, and on the son of his first marriage; and investing a large fortune in the enterprise of building railroads in Russia, re-married in that country. Randolph Middleton was the only child of this marriage, as his American brother had been of the first. Though inheriting the title and estates of his mother, he preferred the independence of his father's nationality and name to the restraint and surveillance with which the Russian government honors the members of its national family. The hope having been expressed that "Gypsy had behaved well," Mr. Middleton related that during the tedium of awaiting their train, Gypsy had pounced on his cap as ferociously as though it had been her legitimate prey of a rat. In the scuffle for its recovery, the lining had been torn away, doing him the good turn of discovering a lost ring of much value, which had lain entangled for eight days in the lining. Alice answered his meaning emphasis with her shy, pretty smile, and Middleton took his leave, wondering how much she knew of it.

The life of English and Americans wintering in Rome is familiar to all: threading the long miles of the intricate Vatican galleries of antique art; visiting churches and views, pictures, palaces and ruins; excursions by daylight to Tivoli, by moonlight to the Coliseum; drives on the Appian way; hunts on the Campagna; rides to the neighboring villas; walks through the quaint squares and tortuous streets; their carriages pacing the narrow length of the Corso, or stationed on the Pincian height, surrounded by the loungers who are gathered

there only to talk and stare, while the really good band is playing music well worth their attention. These people were all leading the same lives, going to the same places; therefore meeting one another at every turn, as Randolph Middleton and Alice Fairfax met during the months following the discovery of his still inexplicable blunder. Alice could have given the clue to this mystery, had he found the opportunity he sought for an effective explanation, but Rome gives little chance for private interviews; where tourists were not swarming, there beggars cropped up. Vainly Middleton planned for a chance to replace the lost ring on her finger; vainly he rehearsed in a day-dream his tale of love and hope; they were never alone. When they stood in the moonlight, looking down from the topmost circle of the grim Coliseum, a dozen people stood with them; in the darkness of the catacombs, torch-bearing guides marched at their side; in the bowers of Borghése, or the groves of Pamphili, in gallery, studio, or church, under the dome of St. Peter's, in the grounds of the Capitol, some unconscious intruder forever haunted their steps.

One morning, these two had drawn apart from a gay picnic at the baths of Caracalla. Alice sat under a broken arch festooned with vines. Middleton leant against the wall at her side, and read "Casa Guidi Windows" aloud. A cool breeze tempered the sun's heat; the breath of spring softened the air.

"They met like crowned kings;"—

there the reading stopped; the hour had come—the book was closed.

"Months ago," began Middleton, in a whisper, "your hand lay accidentally in mine, taking possession of my heart; you did not know this, for you were sleeping all the while."

He was bending down over her drooping head, and could not see the faint smile which curved her lips at the masculine credulity of this positive assertion.

"Your ring remained in my keeping," continued he. "That fact you know; how you know it, I cannot guess. May my hand replace the ring on your finger, as some encouragement to go on with an explanation necessary to the happiness of my future life?"

Middleton drew forth his purse, in which the star-set diamond out-glittered the gold coins. Alas! the sight of that purse brought

from his lurking-place near them a stalwart beggar, crying "*Per l'amor de Dio!*" and before his clamor was appeased, Helen came gliding toward the disturbed couple. Everything was going wrong: with the coins, rolled out the ring, bounding to Helen's feet, who instantly picked it up, exclaiming:

"My lost ring!"

"Yours!" echoed Middleton. "Impossible!"

Helen appealed to her sister, who, though struggling with an inclination to laugh and an equally strong inclination to cry, answered,

"It is yours," and hastened away.

"Are we playing a 'Comedy of Errors'?" cried Middleton. "Miss Fairfax," he continued, impetuously, "permit me to place that ring on your finger."

"Thank you, no," was the cold reply; "I never wear rings."

Middleton's excitement was over. The hand was aristocratic, and intellectual, and fair; but ah! it was not the dimpled one that had nestled in his! He lifted the reluctant fingers to his lips, then gently released them; but not before Sir John Farleigh had been maddened by the sight of the apparent caress. Middleton disappeared in pursuit of Alice. Sir John, who was approaching, turned on his heel and departed. Helen stood quite speechless with indignation against both; then she quietly put the ring in her pocket, drew on her glove, and glided off to rejoin the gay picnickers. When Middleton led Alice back, Helen was gone, and they stood under the green-canopied arch, her hand in his, her eyes downcast, her head pressed to his breast, and her lips uttering once more the sigh he loved!

"Now," whispered the lover, "two questions! Those tears?"

"Life itself seemed a sin, and so vague," answered Alice. "I was trying to shut mine up in a convent."

"You dear little saint! and so you changed seats while I slept, with your unconscious sister? You sweet little witch! Is there anything else to confess!"

"Yes," she murmured. "Mr. Middleton, I was not asleep *all the time*; I woke to find our hands clasped, and was frightened; then you took such good care, and outwitted the watchful Sir John so cleverly, that somehow, I began to like you."

"Ah! since you *like* me, that is all that I can desire. And the ring?"

"I wore Helen's ring."

WHIP-POOR-WILL.

THE Western sky blazed through the trees,
 And in the East the dove-light shone;
 Low fields of clover to the breeze
 Gave out a fragrant monotone;
 While sharp-voiced, whirring things beyond
 Sent a faint treble through the air,
 And discords of the hidden pond
 Pulsed like an anthem, deep and rare.
 Yet all the twilight range seemed still,
 The tumult was so subtle-sweet;
 When forth it burst,—clear, slow, complete,
 The evening call of
 “Whip-poor-will!”

The yarrow, crowding by the hedge,
 Stirred not its specked, uncertain white;
 The locust on the upland's edge
 Stood tranced against the blaze of light.
 For now the throbbing air was mute,
 Since the wild note had pierced it through,—
 That call so clear, so resolute,
 So tender, dominant and true.
 When, suddenly, across the hill,—
 Long, low and sweet, with dreamy fall,
 Yet true and mellow, call for call,
 Elate; and with a human thrill,—
 Came the far answer:
 “Whip-poor-will!”



THE STARS.

THEY wait all day unseen by us, unfelt;
 Patient they bide behind the day's full glare;
 And we who watched the dawn when they were there
 Thought we had seen them in the daylight melt
 While the slow sun upon the earth-line knelt.
 Because the teeming sky seemed void and bare,
 But for light cloudlets in the dazzled air,
 We had no thought that there all day they dwelt.
 Yet were they over us, alive and true,
 In the vast shades far up above the blue,—
 The brooding shades beyond our daylight ken,—
 Serene and patient in their conscious light,
 Ready to sparkle for our joy again,—
 The eternal jewels of the short-lived night.

ILKA ON THE HILL-TOP.

MR. JULIUS HAHN and his son Fritz were on a summer journey in the Tyrol. They had started from Mayrhofen early in the afternoon, on two meek-eyed, spiritless farm horses, and they intended to reach Ginzling before night-fall.

There was a great blaze of splendor hidden somewhere behind the western mountain-tops; broad bars of fiery light were climbing the sky, and the chalets and the Alpine meadows shone in a soft crimson illumination. The Zemmbach, which is of a choleric temperament, was seething and brawling in its rocky bed, and now and then sent up a fierce gust of spray, which blew, like an icy shower-bath, into the faces of the travelers.

"*Ach, welch verfluchtes Wetter!*" cried Mr. Hahn fretfully, wiping off the streaming perspiration. "I'll be blasted if you catch me going to the Tyrol again for the sake of being fashionable!"

"But the scenery, father, the scenery!" exclaimed Fritz, pointing toward a great, sun-flushed peak, which rose in majestic isolation toward the north.

"The scenery—bah!" growled the senior Hahn. "For scenery, recommend me to Saxon Switzerland, where you may sit in an easy cushioned carriage without blistering your legs, as I have been doing to-day in this blasted saddle."

"Father, you are too fat," remarked the son, with a mischievous chuckle.

"And you promise fair to tread in my footsteps, son," retorted the elder, relaxing somewhat in his ill-humor.

This allusion to Mr. Fritz's probable corpulence was not well received by the latter. He gave his horse a smart cut of the whip, which made the jaded animal start off at a sort of pathetic mazurka gait up the side of the mountain.

Mr. Julius Hahn was a person of no small consequence in Berlin. He was the proprietor of the "Haute Noblesse" concert garden, a highly respectable place of amusement, which enjoyed the especial patronage of the officers of the Royal Guard. Weiss-beer, Bairisch, Seidel, Pilsner, in fact all varieties of beer, and as connoisseurs asserted, of exceptional excellence, could be procured at the "Haute Noblesse;" and the most ingenious novelties in the way of gas illumination, besides two military bands,

tended greatly to heighten the flavor of the beer, and to put the guests in a festive humor. Mr. Hahn had begun life in a small way with a swallow-tail coat and a white choker, and a napkin on his arm; his stock in trade, which he utilized to good purpose, was a peculiarly elastic smile and bow, both of which he accommodated with extreme nicety to the social rank of the person to whom they were addressed. He could listen to a conversation in which he was vitally interested, never losing even the shadow of an intonation, with a blank neutrality of countenance which could only be the result of a long transmission of ancestral vacancy. He read the depths of your character, divined your little foibles and vanities, and very likely passed his supercilious judgment upon you, seeming all the while the personification of uncritical humility.

It is needless to say that Mr. Hahn picked up a good deal of valuable information in the course of his career as a waiter; and to him information meant money, and money meant power and a recognized place in society. The diplomatic shrewdness which enabled him to estimate the moral caliber of a patron served him equally well in estimating the value of an investment. He had a hundred subterranean channels of information, and his judgment as to the soundness or unsoundness of a financial enterprise was almost unerring. His little secret transactions on the Bourse, where he had his *commissionaires*, always yielded him ample returns; and when an opportunity presented itself, which he had long foreseen, of buying a suburban garden at a bankrupt sale, he found himself, at least preliminarily, at the goal of his ambition. From this time forth, Mr. Hahn rose rapidly in wealth and power. He kept his thumb, so to speak, constantly on the public pulse, and prescribed amusements as unerringly as a physician prescribes medicine, and usually, it must be admitted, with better results. The "Haute Noblesse" became the favorite resort of fashionable idlers, among whom the military element usually preponderated, and the flash of gilt buttons and the rattle of swords and scabbards could always be counted on as the unvarying accompaniment to the music.

With all his prosperity, however, Mr.

Hahn could not be called a happy man. He had one secret sorrow, which, until within a year of his departure for the Tyrol, had been a source of constant annoyance: Mrs. Hahn, whom he had had the indiscretion to marry before he had arrived at a proper recognition of his own worth, was not his equal in intellect; in fact, she was conspicuously his inferior. She had been chamber-maid in a noble family, and had succeeded in marrying Mr. Hahn simply by the fact that she had made up her mind not to marry him. Mr. Hahn, however, was not a man to be baffled by opposition. When the pert Mariana had cut him three times at a dancing hall, he became convinced that she was the one thing in the world which he needed to make his existence complete. After presenting him with a son, Fritz, and three rather unlovely daughters, she had gradually lost all her pertness (which had been her great charm) and had developed into a stout, dropsical matron, with an abundance of domestic virtues. Her principal trait of character had been a dogged, desperate loyalty. She was loyal to her king, and wore his favorite flowers as jewelry. She was loyal to Mr. Hahn, too; and no amount of maltreatment could convince her that he was not the best of husbands. She adored her former mistress and would insist upon paying respectful little visits to her kitchen, taking her children with her. This latter habit nearly drove her husband to distraction. He stamped his feet, he tore his hair, he swore at her, and I believe, he even struck her; but when the next child was born,—a particularly wonderful one,—Mrs. Hahn had not the strength to resist the temptation of knowing how the new-born wonder would impress the Countess von Markenstein. Another terrible scene followed. The poor woman could never understand that she was no longer the wife of a waiter, and that she must not be paying visits to the great folks in their kitchens.

Another source of disturbance in Mr. Hahn's matrimonial relations was his wife's absolute refusal to appear in the parquet or the proscenium boxes in the theater. In this matter her resistance bordered on the heroic; neither threats nor entreaties could move her.

"Law, Julius," she would say, while the tears streamed down over her plump cheeks, "the parquet and the big boxes are for the gentlefolks, and not for humble people like you and me. I know my place, Julius, and

I don't want to be the laughing-stock of the town, as I should be, if I went to the opera and sat where my lady the Countess, and the other fine ladies sit. I should feel like a fool, too, Julius, and I should cry my eyes out when I got home."

It may easily be conjectured that Mr. Hahn's mourning covered a very light heart when the dropsy finally carried off this loving but troublesome spouse. Nor did he make any secret of the fact that her death was rather a relief to him, while on the other hand he gave her full credit for all her excellent qualities. Fritz, who was in cordial sympathy with his father's ambition for social eminence, had also learned from him to be ashamed of his mother, and was rather inclined to make light of the sorrow which he actually felt when he saw the cold earth closing over her.

At the time when he made his summer excursion in the Tyrol, Fritz was a stout blonde youth of two and twenty. His round, sleek face was not badly modeled, but it had neither the rough openness characteristic of a peasant, nor yet that indefinable finish which only culture can give. In spite of his jaunty, fashionable attire, you would have put him down at once as belonging to what in the Old World is called "the middle class." His blue eyes indicated shrewdness, and his red cheeks habitual devotion to the national beverage. He was apparently a youth of the sort that Nature is constantly turning out by the thousand—mere weaker copies of progenitors, who by an unpropitious marriage have enfeebled instead of strengthening the type. Circumstances might have made anything of him in a small way; for, as his countenance indicated, he had no very pronounced proclivities, either good or bad. He had spent his boyhood in a gymnasium, where he had had greater success in trading jackknives than in grappling with Cicero. He had made two futile attempts to enter the Berlin University, and had settled down to the conviction that he had mistaken his calling, as his tastes were military rather than scholarly; but, as he was too old to rectify this mistake, he had chosen to go to the Tyrol in search of pleasure rather than to the Military Academy in search of distinction.

At the mouth of the great ravine of Dornauberg the travelers paused and dismounted. Mr. Hahn called the guide, who was following behind with a horse laden with baggage, and with his assistance a

choice repast, consisting of all manner of cold curiosities, was served on a large flat rock. The senior Hahn fell to work with a will and made no pretense of being interested in the somber magnificence of the Dornauberg, while Fritz found time for an occasional exclamation of rapture, flavored with caviar, Rhine wine, and *paté de foie gras*.

"*Ach, Gott, Fritz, what stuff you can talk!*" grumbled his father, sipping his Johannisberger with the air of a connoisseur. "When I was of your age, Fritz, I had—hush, what is that?"

Mr. Hahn put down his glass with such an energy that half of the precious contents was spilled.

"*Ach, du lieber Gott,*" he cried a moment later. "*Wie wunderschön!*"

From a mighty cliff overhanging the road, about a hundred feet distant, came a long yodling call, peculiar to the Tyrol, sung in a superb ringing baritone. It soared over the mountain peaks and died away somewhere among the Ingent glaciers. And just as the last faint note was expiring, a girl's voice, fresh and clear as a dew-drop, took it up and swelled it and caroled it until from sheer excess of delight it broke into a hundred leaping, rolling and warbling tones, which floated and gamboled away over the highlands, while soft-winged echoes bore them away into the wide distance.

"Father," said Fritz, who was now lying outstretched on a soft Scotch plaid smoking the most fragrant of weeds; "if you can get those two voices to the 'Haute Noblesse,' for the next season, it is ten thousand thalers in your pocket; and I shall only charge you ten per cent. for the suggestion."

"Suggestion, you stupid! Why, the thought flashed through my head the very moment I heard the first note. But hush—there they are again."

From the cliff, sung to the air of a Tyrol-ese folk-song, came this stanza:

Tell me, Ilka on the hill-top,
While the Alpine breezes blow,
Are thy golden locks as golden
As they were a year ago?
(Yodle) Hohli-ohli-ohli-ho!
Hohli-ohli-ohli-ho! Hohli-oh!

The effect of the yodle, in which both the baritone of the cliff and the Alpine soprano united, was so melodious that Mr. Hahn sprang to his feet and swore an ecstatic oath, while Fritz, from sheer admiring ab-

straction, almost stuck the lighted end of his cigar into his mouth. The soprano answered:

Tell me, Hänsel in the valley,
While the merry cuckoos crow,
Is thy bristly beard as bristly
As it was a year ago?
Hohli-ohli-ohli-ho!
Hohli-ohli-ohli-ho! Hohli-oh!

The yodling refrain this time was arch, gay—full of mocking laughter and mirth. Then the responsive singing continued:

Hänsel: Tell me, Ilka on the hill-top,
While the crimson glaciers glow,
Are thine eyes as blue and beaming
As they were a year ago?
Both: Hohli-ohli, etc.

Ilka: Hänsel, Hänsel in the valley,
I will tell you, tell you true;
If mine eyes are blue and beaming,
What is that, I pray, to you?
Both: Hohli-ohli, etc.

Hänsel: Tell me, Ilka on the hill-top,
While the blushing roses blow,
Are thy lips as sweet for kissing
As they were a year ago?
Both: Hohli-ohli, etc.

Ilka: Naughty Hänsel in the valley,
Naughty Hänsel, tell me true,
If my lips are sweet for kissing,
What is that, I pray, to you?
Both: Hohli-ohli, etc.

Hänsel: Tell me, Ilka on the hill-top,
While the rivers seaward flow,
Is thy heart as true and loving
As it was a year ago?
Both: Hohli-ohli, etc.

Ilka: Dearest Hänsel in the valley,
I will tell you, tell you true.
Yes, my heart is ever loving,
True and loving unto you!
Both: Hohli-ohli-ohli-ho!
Hohli-ohli-ohli-ho! Hohli-oh!

For a few moments their united voices seemed still to be quivering in the air, then to be borne softly away by the echoes into the cool distance of the glaciers. A solitary thrush began to warble on a low branch of a stunted fir-tree, and a grasshopper raised its shrill voice in emulation. The sun was near its setting; the bluish evening shadows crept up the sides of the ice-peaks, whose summits were still flushed with expiring tints of purple and red.

Mr. Hahn rose, yawned and stretched his limbs. Fritz threw the burning stump of his cigar into the depths of the ravine, and stood watching it with lazy interest while it fell. The guide cleared away the remnants

of the repast and began to resaddle the horses.

"Who was that girl we heard singing up on the Alp?" said Mr. Hahn, with well-feigned indifference, as he put his foot in the stirrup and made a futile effort to mount. "Curse the mare, why don't you make her stand still?"

"Pardon, your honor," answered the guide stolidly; "but she isn't used to the saddle. The girl's name is Ilka on the Hill-top. She is the best singer in all the valley."

"Ilka on the Hill-top! How—where does she live?"

"She lives on a farm called the Hill-top, a mile and a half from Mayrhofen."

"And the man who answered—is he her sweetheart?"

"Yes, your honor. They have grown up together, and they mean to marry sometime, when they get money enough to buy out the old woman."

"And what did you say his name was?"

"Hänsel the Hunter. He is a garnet polisher by trade, because his father was that before him; but he is a good shot and likes roving in the woods better than polishing stones."

"Hm," grumbled Mr. Hahn, mounting with a prodigious effort.

II.

It was in the autumn of 1863, only a few weeks after Mr. Hahn's visit to Ginzling and Dornauberg. There was war and rumors of war in the air. The Austrians and the Prussians were both mobilizing army-corps after army-corps, and all the Tyrolese youth, liable to service, were ordered to join their regiments. The Schleswig-Holstein question was being violently debated in the German and the English press, the former clamoring for blood, the latter counseling moderation. The Danish press was as loud-mouthed as any, and, if the battles could have been fought with words, would no doubt have come out victorious.

It had been a sad day at the Hill-top. Early in the morning Hänsel, with a dozen other young fellows of the neighborhood, had marched away to the music of fife and drum, and there was no knowing when they would come back again. A dismal whitish fog had been hovering about the fields all day long, but had changed toward evening into a fine drizzling rain,—one of those slow, hopeless rains that seem to have no

beginning and no end. Old Mother Uberta, who, although she pretended to be greatly displeased at Ilka's matrimonial choice, persisted in holding her responsible for all her lover's follies, had been going about the house grumbling and scolding since the early dawn.

"Humph," said Mother Uberta, as she lighted a pine-knot and stuck it into a crack in the wall (for it was already dark, and candles were expensive), "it is a great sin and shame—the lad is neither crooked nor misshapen—the Lord has done well enough by him, Heaven knows; and yet never a stroke of work has he done since his poor father went out of the world as naked as he came into it. A shiftless, fiddling and galavanting set they have always been, and me then, as has only this one lass, givin' her away, with my eyes wide open, into misery."

Ilka, who was sitting before the open fireplace mingling her furtive tears with the wool she was carding, here broke into a loud sob, and hid her face in her hands.

"You always say mean things to me, mother, when Hänsel is away," sobbed she, "but when he is here, you let on as if you liked him ever so much."

The mother recognized this as a home-thrust, and wisely kept silent. She wet her finger-tips, twirled the thread, stopped the wheel, inspected some point in its mechanism with a scowl of intense preoccupation, and then spun on again with a severe concentration of interest as if lovers were of small consequence compared to spinning-wheels. Mother Uberta was a tall, stately woman of fifty, with a comely wrinkled face, and large well-modeled features. You saw at once that life was a serious business to her, and that she gave herself no quarter.

"Humph!" she began after a while with that indefinable interjection of displeasure which defies all spelling. "You talk like the witless creature that you are. Didn't I tell the lad, two years ago, Michaelmas was, that the day he could pay off the mortgage on the farm, he should have you and the farm too? And eight hundred and fifty florins oughtn't to frighten a man as has got the right spirit in him. And there was Ruodi of Gänzelstein, as has got a big farm of his own, and Casper Thinglen with fifteen hundred a-comin' to him when his grandfather dies; and you sendin' them both off with worse grace than if they had been beggars askin' you for a shillin'. Now, stop your snivelin' there, I tell you. You are like

your poor sainted father,—God bless him where he lies,—he too used to cry, likely enough, if a flea bit him."

At this moment Mother Uberta's monologue was interrupted by a loud rapping on the door; she bent down to attach the unfinished thread properly, but before she had completed this delicate operation, the door was opened, and two men entered. Seeing that they were strangers she sent them a startled glance which presently changed into one of defiance. The fire was low and the two men stood but dimly defined in the dusky light; but their city attire showed at once that they were not Tyrolese. And Mother Uberta, having heard many awful tales of what city-dressed men were capable of doing, had a natural distrust of the species.

"And pray, sir, what may your errand be?" she asked sternly, taking the burning pine knot from its crack and holding it close to the face of the tallest stranger.

"My name is Hahn, madam," answered the person whose broad expanse of countenance was thus suddenly illuminated, "and this is my son, Mr. Fritz Hahn. Allow me to assure you, madam, that our errand here is a most peaceful and friendly one, and that we deeply regret it, if our presence incommodes you."

"Ilka, light the candles," said Mother Uberta, sullenly. "And you," she continued, turning again to Mr. Hahn, "find yourself a seat, until we can see what you look like."

"What a vixen of an old woman!" whispered the proprietor of the "Haute Noblesse" to his son, as they seated themselves on the hard wooden bench near the window.

"Small chance for the 'Haute Noblesse,' I fear," responded Fritz, flinging his traveling cap on the clean-scoured deal table.

Ilka, who in the meanwhile had obeyed her mother's injunction, now came forward with two lighted tallow dips, stuck in shining brass candlesticks, and placed them on the table before the travelers. She made a neat little courtesy before each of them, to which they responded with patronizing nods.

"*Parbleu! Elle est charmante!*" exclaimed Fritz, fixing a bold stare on the girl's blushing face.

"*Bien charmante,*" replied Mr. Hahn, who took a great pride in the little French he had picked up when he carried a napkin over his shoulder.

And indeed, Ilka was *charmante* as she stood there in the dim candle-light, her

great innocent eyes dilated with child-like wonder, her thick blonde braids hanging over her shoulders, and the picturesque Tyrolese costume—a black embroidered velvet waist, blue apron and short black skirt—setting off her fine figure to admirable advantage. She was a tall, fresh-looking girl, of stately build, without being stout, with a healthy blooming countenance and an open guileless expression. Most people would have pronounced her beautiful, but her beauty was of that rudimentary, unindividualized kind which is found so frequently among the peasantry of all nations. To Fritz Hahn, however, who was not a philosophical observer, she seemed the most transcendent phenomenon his eyes had ever beheld.

"To make a long story short, madam," began Mr. Hahn after a pause, during which Mother Uberta had been bristling silently while firing defiant glances at the two strangers, "I am the proprietor of a great establishment in Berlin—the 'Haute Noblesse'—you may have heard of it."

"No, I never heard of it," responded Mother Uberta emphatically, as if anxious to express her disapproval, on general principles, of whatever statements Mr. Hahn might choose to make.

"Well, well, madam," resumed the latter a trifle disconcerted, "it makes very little difference whether you have heard of it or not. I see, however, that you are a woman of excellent common sense, and I will therefore be as brief as possible—avoid circumlocutions, so to speak."

"Yes, exactly," said Mother Uberta, nodding impatiently, as if eager to help him on.

"Madam Uberta,—for that, as I understand, is your honored name,—would you like to get one thousand florins?"

"That depends upon how I should get 'em," answered the old woman sharply. "I should n't like to get 'em by stealin'."

"I mean, of course, if you had honestly earned them," said Hahn.

"I am afeard honesty with you and with me is n't exactly the same thing."

Mr. Hahn was about to swear, but mindful of his cherished enterprise, he wisely refrained.

"I beg leave to inform you, Madam Uberta," he observed, "that it is gentlemen of honor you have to deal with, and that whatever proposals they may make you will be of an honorable character."

"And I am very glad to hear that, I am sure," responded the undaunted Uberta.

"Three weeks ago, when we were traveling in this region," continued Hahn, determined not to allow his temper to be ruffled, "we heard a most wonderful voice yodling in the mountains. We went away, but have now returned, and having learned that the voice was your daughter's, we have come here to offer her a thousand florins if she will sing her native Tyrolese airs for eight weeks at our Concert Garden, the 'Haute Noblesse.'"

"One thousand florins for eight weeks, mother!" exclaimed Ilka, who had been listening to Hahn's speech with breathless interest. "Then I could pay off the mortgage and we should not have to pay interest any more, and I should have one hundred and fifty florins left for my dowry."

"Hush, child, hush! You don't know what you are talkin' about," said the mother severely. Then turning to Hahn: "I should like to put one question to both of you, and when you have answered that, I'll give my answer, which there is no wriglin' out of. If the old woman went along, would ye *then* care so much about the singin' of the daughter?"

"Certainly, by all means," responded Hahn promptly; but Fritz was so absorbed in polishing his finger nails with a little instrument designed especially for that purpose, that he forgot to answer.

A long consultation now followed, and the end of it was that Ilka agreed to go to Berlin and sing for eight weeks, in her national costume, on condition that her traveling expenses and those of her mother should be defrayed by the manager. Mr. Hahn also agreed to pay for the board and lodgings of the two women during their sojourn in the capital and to pay Ilka the one thousand florins (and this was a point upon which Mother Uberta strenuously insisted) in weekly installments.

The next day the contract was drawn up in legal form, properly stamped and signed; whereupon Mother Uberta and Ilka started with Hahn and Fritz for Berlin.

III.

THE restaurant of the "Haute Noblesse" was a splendid specimen of artistic decoration. The walls were frescoed with all sorts of marvelous hunting scenes, which Fritz had gradually incorporated in his own autobiography. Here stags were fleeing at a furious speed before a stout young gentleman on horseback, who was leveling his deadly aim

at them; there the same stout young gentleman, with whiskers and general appearance slightly altered, was standing behind a big tree, firing at a hare who was coming straight toward him, pursued by a pack of terrible hounds; again, on a third wall, the stout young gentleman had undergone a further metamorphosis which almost endangered his identity; he was standing at the edge of a swamp, and a couple of ducks were making somersaults in the air, as they fluttered with bruised wings down to where the dogs stood expecting them; on wall number four, which contained the *chef-d'œuvre* of the collection, the young Nimrod, who everywhere bore a more or less remote resemblance to Fritz Hahn, was engaged in a mortal combat with a wild boar, and was performing miraculous feats of strength and prowess. The next room,—to which it was, for some unknown reason, deemed a high privilege to be admitted,—was ornamented with a variety of trophies of the chase, which were intended, no doubt, as incontestable proofs of the veracity of the frescoed narrative. There were stuffed stags' heads crowned with enormous antlers (of a species, as a naturalist asserted, which is not found outside of North America), heads of bears, the insides of whose mouths were painted in the bloodiest of colors, and boars whose upward-pointed tusks gave evidence of incredible blood-thirstiness. Even the old clock in the corner (a piece of furniture which every customer took pains to assure Mr. Hahn that he envied him) had a frame of curiously carved and intertwined antlers, the ingenious workmanship of which deserved all the admiration which it received. Mr. Hahn had got it for a song at an auction somewhere in the provinces; but the history of the clock which Fritz told omitted mentioning this incident.

In this inner room on the 19th of April, 1864, Mr. Hahn and his son were holding a solemn consultation. The news of the fall of Düppel, and the consequent conquest of all Schleswig, had just been received, and the capital was in a fever of warlike enthusiasm. That two great nations like the Prussians and the Austrians, counting together more than fifty millions, could conquer poor little Denmark, with its two millions, seemed at that time a great and glorious feat, and the conquerors have never ceased to feel proud of it. Mr. Hahn, of course, was overflowing with loyalty and patriotism, which, like all his other senti-

ments, he was anxious to convert into cash. He had therefore, made arrangements for a *Siegesfest*, on a magnificent scale, which was to take place on the second of May, when the first regiments of the victorious army were expected in Berlin. It was the details of this festival which he and Fritz had been plotting in the back room at the restaurant, and they were both in a state of agreeable agitation at the thought of the tremendous success which would, no doubt, result from their combined efforts. It was decided that Ilka, whom by various pretexts Mr. Hahn had managed to detain in Berlin through the whole winter, should appear in a highly fantastic costume as Germania, and sing "Die Wacht am Rhein" and "Heil dir im Siegeskranz," as a greeting to the returning warriors. If the weather proved favorable, the garden was to be brilliantly illuminated, and the likenesses of King Wilhelm, Bismarck and von Moltke were to appear in gas-jets, each surmounting a triumphal arch, which was to be erected in front of the stage and at the two entrances to the garden.

"As regards that Tyrolese wench," said Fritz, as he lighted a fresh cigar, "are you sure we can persuade her to don the Germania costume? She seems to have some pretty crooked notions on some points, and the old woman, you know, is as balky as a stage horse."

"Leave that to me, Fritzchen, leave that to me," replied the father, confidently. "I know how to manage the women. Thirty years' practice, my dear—thirty years' practice goes for more in such matters than a stripling like you can imagine."

This remark, for some reason, seemed to irritate Mr. Fritz exceedingly. He thrust his hands deeply into his pockets, and began to stalk up and down the floor with a sullen, discontented air.

"Aha! you old fox," he muttered to himself, "you have been hunting on my preserves. But I'll catch you in your own trap, as sure as my name is Fritz."

"The sly young rascal!" thought Mr. Hahn; "you have been sniffing in your father's cupboard, have you?"

"Fritz, my dear," he said aloud, stretching himself with a long, hypocritical yawn, "it is ridiculous for two fellows like you and me to wear masks in each other's presence. We don't care a straw for the whole *Sieges* business, do we, Fritz, except for the dollars and cents of it? I am deucedly sleepy, and I am going to bed."

"And so am I, father dear," responded Fritz, with a sudden outburst of affection. "Yes, yes, father," he continued heartily, "you and I understand each other. I am a chip of the old block, I am—he, he!"

And with the most effusive cordiality this affectionate parent and son separated, with the avowed purpose of seeking oblivion in slumber, in their respective apartments.

"Perhaps I have been doing the old fellow injustice, after all," thought Fritz, as he clasped his father's hand once more at the bottom of the staircase.

"The young gosling hasn't ventured into such deep water as I thought," murmured the happy father, as he stood listening to Fritz's footsteps re-echoing through the empty corridors.

IV.

MR. HAHN, SR., having satisfied himself as to his son's sincerity, retired to his private chamber; not for the purpose of going to rest, however, but in order to make an elaborate toilet, having completed which, he hailed a droschke and drove to an obscure little street in the Friedrich-Wilhelm Stadt, where he ordered the coachman to stop. As he was preparing to dismount, to his astonishment he saw another droschke driving away from the door which he was intending to enter.

"Hm," growled Hahn, "if she has been making acquaintances, she isn't the girl I took her for. But there are other people living in the house, and the visit may not have been for her."

Clinging fondly to this hope, he climbed with wary steps two flights of dark and narrow stairs, which was no easy feat for an elderly gentleman of his bulk. As he reached the second landing, panting and breathless, he found himself in violent contact with another person, who, like himself, seemed to be fumbling for the bell-handle.

"Beg your pardon, sir," said a voice in the dark.

"What, you sneaking young villain!" cried Hahn in great wrath (for the voice was only too familiar to him); "I might have known you were up to some devilish trick, or you wouldn't —"

Here the senior Hahn choked, and was seized with a violent coughing fit.

"You miserable old sinner!" hissed Fritz; "the devil has already got his finger on your throat."

This was too much for Mr. Hahn; he made a rush for his rival, and in a moment he and Fritz were grappling furiously in the dark. It seemed about an even chance who was to be precipitated down the steep staircase; but just as the father was within an inch of the dangerous edge, the hall door was torn open, and Mother Uberta, followed by Ilka with a lamp in her hand, sprang forward, grasped the combatants in her strong arms and flung them against the opposite wall. They both fell on the floor, but each managed, without serious injury, to extricate himself from the other's embrace.

"You are a fine, well-behaved lot, you are!" broke out Mother Uberta, planting herself, with arms akimbo, in front of the two culprits, and dispensing her adjectives with equal liberality to both.

"It was a mistake, madam, I assure you," said Hahn huskily, as he pulled out his handkerchief, and began to whip the dust off his trowsers.

The wreath of thin hair which he had carefully combed, so as to make the nakedness of his crown less conspicuous, was bristling toward all the points of the compass. His tall hat had gone on an independent journey down the stairs, and was heard tumbling deliberately from step to step. Fritz, who had recovered himself much more rapidly, seemed to have forgotten that he had himself borne any part in the disgraceful scene; he looked at his father with kind of a pitying superiority, and began to assist him in the repair of his toilet, with the air of an officious outsider, all of which the crest-fallen father endured with great fortitude. He seemed only anxious to explain the situation to the two women, who were still viewing him with marked disapproval.

"It was all a mistake, madam—a great mistake," he kept repeating.

"A great mistake," ejaculated Mother Uberta, contemptuously. "This isn't a time to be makin' mistakes outside the door of two lonely women."

"It is fifteen minutes past nine," said Hahn meekly, pulling a corpulent gold watch from the pocket of his waistcoat.

"Madam," said Fritz, without the slightest air of apology, "I came here to consult you on a matter of business, which would bear no delay."

"Exactly, exactly," interrupted Hahn eagerly. "So did I, a matter of business which would bear no delay."

"Well, *Väterchen*, we are simple country

women, and we don't understand city manners. But if you want to see me on business, I shall be at home to-morrow at twelve o'clock."

So saying, Mother Uberta slammed the door in the faces of her visitors, and left them to grope their way in the dark down the steep stairway. It was highly characteristic, both of the senior and the junior Hahn, that without a word of explanation they drove home amicably in the same droschke.

Ilka's engagement at the "Haute Noblesse" in the autumn had proved a great success, and Mother Uberta, who was never averse to earning money, had without difficulty, been persuaded to remain in Berlin during the winter, on condition of the renewal of their contract for another six weeks in the spring. Ilka was in the meanwhile to take lessons in singing at Hahn's expense, possibly with a view to future distinction as a prima donna of the opera. Her *maestro* had told her repeatedly that she had naturally a better voice than Nilsson, and that, if she could dry up for ever her fountain of tears, she might become a great *artiste*. For Ilka had the deplorable habit of crying on very slight provocation. The *maestro*, with his wild hair, his long, polished nails and his frantic gesticulations frightened and distressed her; she thought and spoke of him as a kind of curious animal, and nothing could persuade her that he and she belonged to the same species. Nor did Mr. Hahn and Fritz seem to her more than half human. Their constant presents and attentions sometimes annoyed, and frequently alarmed her. She could not rid herself of the apprehension, that behind their honeyed words and manners they were hiding some sinister purpose. She could not comprehend how her mother could talk so freely and fearlessly with them. She thought of Hänsel, who was away in the war, and many an evening she stood outside the telegraph-office with a quaking heart, waiting for the bulletin with the names of the dead and the wounded; but Hänsel's name was never among them. And many a night she lay awake, yearning for Hänsel, praying for him and blessing him. She seemed to hear his gay and careless laugh ringing from Alp to Alp—how different from the polite smirk of the junior, the fat grin of the senior Hahn! She saw his tall, agile figure standing upon a rock leaning upon his gun, outlined against the blue horizon,—and she heard his strong clear voice yodling and

calling to her from afar. It is not to be wondered at that Ilka did not thrive in Berlin as well as her mother did; just as the tender-petaled alpine rose can only breathe the cool breezes of its native mountains, and withers and droops if transplanted to a garden.

Mother Uberta was by no means blind to the fact that both Fritz and his father had designs on her daughter, and having convinced herself that their prosperity rested on a solid basis, she was not disinclined to favor their suits. The only difficulty was to make a choice between them; and having ascertained that Fritz was entirely dependent upon his father's bounty, she quickly decided in favor of the father. But she was too wise to allow Mr. Hahn to suspect that he was a desirable son-in-law, being rather addicted to the belief that men only worship what seems utterly beyond their reach. Ilka, it is needless to say, was not a party to these speculations; to her the Hahns appeared equally undesirable in any capacity whatsoever.

As for the proprietor of the "Haute Noblesse," I believe he was suffering from an honest infatuation. He admired Ilka's face, he admired her neck, her figure, her voice, her ankles as displayed by the short Tyrolese skirt; he wandered about in a sort of frenzy of unrest, and was never happy except in her presence. That a certain amount of speculation entered into love's young dream, I cannot positively deny; but, on the whole, the emotion was as sincere as any that Mr. Hahn's bosom had ever harbored. Whether he should allow her to sing in public after she had become his wife was a point about which he sometimes worried, but which he ended by deciding in the affirmative. It was a splendid investment for the "Haute Noblesse."

Mr. Fritz's matrimonial speculations took a somewhat different turn. He raved to his friends about the perfection of Ilka's physical development; talked about her "points" as if she had been a horse. So much of cynicism always mingled with his ardor that his devotion could hardly be dignified by the name of love. He was convinced that if he could keep Ilka for some years in Berlin and persuade her to continue cultivating her voice, she would some day be a great prima donna. And Fritz had an idea that prima donnas always grew immensely rich, and married worthless husbands whom they allowed great liberties in financial matters. Fritz had no objection

to playing this subordinate part, as long as he could be sure of "having a good time." Beyond this point his ambition had never extended. In spite of his great confidence in his own irresistibility, and his frequent boasts of the favors he had received from the maiden of his choice, he knew in his heart that his wooing had so far been very unprosperous, and that the prospects for the future were not encouraging. Ilka could never rid herself of the impression that Fritz was to be taken very seriously,—that, in fact, there was something almost awful about him. She could laugh at old Hahn's jokes, and if he attempted to take liberties she could push him away, or even give him a slap on his broad back. But Fritz's talk frightened her by its very unintelligibility; his mirth seemed terrible; it was like hearing a man laugh in his sleep; and his touch made her shudder.

v.

THE return of the first regiments of the united armies was delayed until after the middle of May, and the *Siegesfest* accordingly had to be postponed. But the delay was rather in Mr. Hahn's favor, as it gave him ample time to perfect his arrangements, so that when the day arrived the "Haute Noblesse" presented a most brilliant appearance. Vividly colored transparencies, representing the most sanguinary battle scenes in more or less fictitious surroundings were suspended among the trees; Danish officers were seen in all sorts of humble attitudes, surrendering their swords or begging for mercy, while the Prussian and Austrian heroes, maddened with warlike fury, stormed onward in the path of glory and victory. The gas-jet programme, with the royal and military portraits, was carried out to perfection; and each new wonder was hailed with immense enthusiasm by the assembled multitude. Innumerable Chinese lanterns glimmered throughout the garden, and from time to time red, white and blue magnesium lights sent up a great blaze of color among the trees, now making the budding leaves blush crimson, now silvering them, as with hoar-frost, or illuminating their delicate tracery with an intense blue which shone out brilliantly against the nocturnal sky. Even the flower-beds were made to participate in the patriotic frenzy; and cunning imitations, in colored glass, of tulips, lilies and roses, with little gas-jets concealed in their chalices, were scattered among the

natural flowers, which looked like ghosts of their real selves among the splendid counterfeits. In order to tune the audience into perfect accord with the occasion, Mr. Hahn had also engaged three monster bands, which, since early in the afternoon, had been booming forth martial melodies from three different platforms draped in national banners.

The hour was now approaching when Germania was to lift up her voice to celebrate the glorious achievements of her sons. The audience, which consisted largely of soldiers and officers, were thronging forward to the tribune where she was advertised to appear, and the waiters, who had difficulty in supplying the universal demand for beer, had formed a line from the bar to the platform, along which the foam-crowned schooners were passing in uninterrupted succession. Fritz, who was fond of fraternizing with the military profession, had attached himself to a young soldier in Austrian uniform with the iron cross upon his bosom. They were seated amicably together at a small table near the stage, and the soldier, by liberal treats of beer, had been induced to relate some of his adventures in the war. He was a tall, robust man, with a large blonde mustache and an open, fearless countenance. He talked very modestly about his own share in the victories, and cooled Fritz's enthusiasm by the extreme plainness of his statements.

"It was rather an uneven game at the start," he said. "They were so few and we were so many. We couldn't have helped whipping them, even if we had done worse than we did."

"You don't mean to say that we were not brave," responded Fritz, with an ardor which was more than half feigned.

"No, I don't say that," said the warrior gravely. "We were brave, and so were they. Therefore the numbers had to decide it."

He emptied his glass and rose to go.

"No, wait a moment," urged Fritz, laying hold of his arm. "Take another glass. You must stay and hear Germania. She is to sing 'Die Wacht am Rhein' and 'Heil dir im Siegeskranz.'"

"Very well," answered the soldier, seating himself again. "I have furlough for to-night, and I can stay here as well as anywhere."

Two more glasses were ordered, and presently arrived.

"Listen!" began Fritz, leaning confiden-

tially across the table. "I suppose you have a sweetheart?"

"Yes, I have, God bless her," replied the other simply, "though I haven't seen her these six months, and not heard from her, either. She isn't much of a hand for writing, and, somehow, I never could get the right crooks on the letters."

"Here's to her health," said Fritz, lifting his glass and touching it to that of his companion.

"With all my heart," responded the latter, and drained the beer mug at one draught.

They sat for a while in silence, Fritz trying to estimate the pecuniary value of the audience, the soldier gazing, with a half-sad and dreamy expression, into the dark sky.

"Curious lot, the women," broke out the junior Hahn, chuckling to himself, as if absorbed in some particularly delightful retrospect. "There is the girl, now, who is to sing as Germania to-night,—and, between you and me, I don't mind telling you that she is rather smitten with me. She is as fine a specimen of a woman as ever trod in two shoes; splendid arms, a neck like alabaster with the tiniest tinge of red in it, and—well, I might expatiate further, but I won't. Now, you wouldn't think it of a girl like that; but the fact is, she is as arch and coquettish as a kitten. It was only the other night I went to see her—the old woman was in the room—"

A tremendous burst of applause completely drowned Fritz's voice, as Germania walked out upon the stage. She was dressed in white, flowing robes, with a golden zone about her waist and a glittering diadem in her hair. A mantle of the finest white cashmere, fastened with a Roman clasp on her left shoulder and drawn through the zone on the right side, showed the fierce Prussian eagle, embroidered in black and gold. A miniature copy of the same glorious bird, also in gilt embroidery, shone on her breast. She had been elaborately trained by her *maestro* as to how she was to step the stage, what attitudes she was to assume, etc., and the first part of the programme she performed very creditably, and with sole reference to her instructions.

The orchestra began to rumble something by way of an introduction. The soldier in the Austrian uniform at Fritz's table turned pale, and sat staring fixedly upon the stage. Ilka stood for a moment gazing out upon the surging mass of humanity at her feet; she heard the clanking of the scabbards and swords, and saw the white and the blue uni-

forms commingled in friendly confusion. Where was Hänsel now—the dear, gay, faithful Hänsel? She struck out boldly, and her strong, sonorous voice soared easily above the orchestral accompaniments. “Heil dir im Siegeskranz!”—she was hailing the returning warriors with a song of triumph, while Hänsel, perhaps, lay on some bloody battle-field, with sightless eyes staring against the awful sky. Ilka’s voice began to tremble, and the tears flooded her beautiful eyes. The soldier in the Austrian uniform trembled, too, and never removed his gaze from the countenance of the singer. There was joy and triumph in her song; but there was sorrow, too—sorrow for the many brave ones that remained behind, sorrow for the maidens that loved them and the mothers that wept for them. As Ilka withdrew, after having finished the last stanza the audience grew almost frantic with enthusiasm; the men jumped up on benches and tables, shouted, and swung their hats, and even the women cheered at the tops of their voices. A repetition was loudly called for, and Ilka, although herself overcome with emotion, was obliged to yield. She walked up to the footlights and began to yodle softly. It sounded strangely airy and far away. She put her hand to her ear and listened for a moment, as if she expected a reply; but there was a breathless silence in the audience. Only a heavy sigh came from the table where Fritz sat with the Austrian soldier. The yodle grew louder; then suddenly some one sprang up, not a dozen rods from the stage, and sang, in a deep, magnificent baritone:

Tell me, Ilka on the hill-top,
While the rivers seaward flow,
Is thy heart as true and loving
As it was a year ago?
Hohli-ohli-ohli-ho!
Hohli-ohli-ohli-ho! Hohli-oh!

Ilka stood for a while as if stunned; her eyes peered in the direction whence the voice had come; her face lighted up with a sweet, serene happiness; but the tears streamed down her cheeks as she answered:

Dearest Hänsel in the valley,
I will tell you, tell you true,
Yes, my heart is ever loving,
True and loving unto you!
Hohli-ohli-ohli-ho!
Hohli-ohli-ohli-ho! Hohli-oh!

Suddenly she made a leap over the edge of the stage, and in the next moment the gorgeous Germania lay sobbing on the soldier’s

bosom. It made a very touching tableau, and some of the male skeptics among the audience were inclined to view it in that light. Fritz Hahn, as soon as the idea was suggested to him, eagerly adopted it, and admitted in confidence to half a dozen friends, whom he had allowed to suspect the fair singer’s devotion to him, that it was all a pre-arranged effect, and that he was himself the author of it.

“Germania weeping on the breast of her returning son,” he said. “What could be more appropriate on a day like this?”

The maidens and matrons, however, would listen to no such theory; they wept openly at the sight of the re-united lovers, and have until this day maintained that the scene was too spontaneous and genuine to be a product of Mr. Hahn’s inventive genius.

The singing of “Die Wacht am Rhein,” although advertised on the programme, had to be indefinitely postponed, for Germania had suddenly disappeared, and was nowhere to be found. The Austrian soldier, however, was seen later in the evening, and some one heard him inquiring in a fierce tone for the junior Hahn; but the junior Hahn, probably anticipating some unpleasantness, had retired from the public gaze.

VI.

Six weeks after this occurrence, it was St. John’s day—there was a merry festival in the village of Mayrhofen. Ilka and Hänsel were bride and groom, and as they returned from church the maidens of the village walked in the wedding procession and strewed flowers before them. And in the evening, when the singing and fiddling and dancing were at an end, and the guests had departed, Mother Uberta beckoned Hänsel aside, and with a mysterious air handed him something heavy tied up in the corner of a handkerchief.

“There,” she said, “is eight hundred and fifty florins. It is Ilka’s own money which she earned in Berlin. Now you may pay off the mortgage, and the farm is yours.”

“Mother Uberta,” answered Hänsel laughing, and pulling out a skin purse from his bosom. “Here is what I have been saving these many years. It is eight hundred and fifty florins.”

“Hänsel, Hänsel,” cried Mother Uberta in great glee, “it is what I have always said of you. You are a jewel of a lad.”

SONNETS

IN MEMORIAM OF THE LATE PRINCE IMPERIAL.*

I.

TO THE EMPRESS.

Nor that thou satest on a golden throne,
 All sylph-like, grace-like, zoned with Cypria's charm;
 Not that a rose uprooted by the storm—
 Forth into exile, Empress, thou wert blown;
 Not that thy beauty to all earth was known;
 Not that thy Cæsar lent us his right arm,
 Is it alone that England, sound and warm,
 Now feels thy mighty sorrow as her own.

A Widowed Mother art thou, placed apart,
 Wailing thy lost one—thy own sole-born boy,
 Thy lamb-like lion, thy young eagle dove.
 'Tis this that stirs the universal heart,
 And shakes the realm, amid the summer joy,
 With a wild wind of pity and pure love.

II.

TO THE PRINCE.

No lovelier nestling of the Eagle race,
 Hath yet flown forth before the eyes of men,
 Than thou, young Prince, just wafted from our ken,
 By God's veiled wisdom, God's especial grace.
 We are the sufferers, we, who knew thy face;
 Not thou, full-freed from this terrestrial den,
 Thou, whose sweet selfless spirit, tongue and pen
 Of years unborn with tenderness will trace.

Hadst thou but lived (who knows?) with wild acclaim
 Thy France had voted thee o'er France to reign,
 Smit with thy spotless worth, thy valor stanch;
 And we had seen united in thy fame,
 The aims, the acts, perchance, of Charlemain,
 With his who was the son of good Queen Blanche!†

III.

TO HIS COMPANIONS-IN-ARMS.

"*The Love of Comrades!*" beautiful devise
 (So fondly dwelt on by Manhattan's bard‡),
 The source wert thou, thou wert the cause ill-starred,
 Which snatched our peerless prince from wistful eyes.
 Beaming with kindness, beaming with emprise,
 Fain would he offer (shelter spurn'd and guard)
 Full sacrifice to friendship. Hard, O hard!
 Lo! on the earth himself a victim lies!

* A companion sonnet by the same author appeared in the September number.

† St. Louis IX.

‡ Walt Whitman.

But ye his comrades, ye, who watched him oft
 Spunging the gun, light-vaulting on the steed,
 In ear-shot of his speech and laughter merry ;
 Recalling his high look and gestures soft,
 Bear that pure memory—pure in thought, word, deed,
 Next to your hearts, like some priz'd reliquary.

PICTURESQUE FEATURES OF KANSAS FARMING.

THERE is no more enticing scene than the Kansas prairies in spring. The eye wanders out over gracefully swerving and unmonotonous lines to what seems the very limit of things; you dare not conjecture where the earth ends and the sky begins. If the grass were a bit more forward, and the atmosphere had only a hint of fog in it, you might liken the vision to a sea; and then those bluish curves would be waves, and that square of newly plowed furrows a shoal of fish, and yonder tall, oblique sycamore a snapped and floating spar, and the one little white house away off there by itself the vague sail of some approaching ship. But the grass is too short, and the air too crisp and dry, for such a simile. Besides, we know this slope of deeper green on our right is early wheat, just high enough for the slight breeze to stir it prettily, as it might stir a baby's hair; and here on our left is a quivering flame of peach-blossoms. There are laughing boys and girls ahead of us, too, on their way to school; and directly we shall be overtaking frequent wagons loaded with lumber, shingles and window-sash; and then will come the elementary in farm-making, and the latest of the arriving settlers. And so the picture goes on, repeating itself for two hundred miles or more,—and beyond that yet is the surveyor, with his spying and beckoning compass.

The farms are large, you will observe, and growing larger, as if they had caught something of the nature of those infinite skies; and at every turn rises that pervasive and undefinable odor of fresh-cut sod. What miles and miles of black overlapping lines, across the emerald prairie where the plows are going! But there are liberal intervals not yet "filed upon" or "opened up," as they name it out here, and the farmers have a keen eye for convenient "ranges" upon which their stock may graze,

and where plenty of hay may be secured in its season at the mere cost of reaping and stacking; it has been asserted that the Kansan would not care to go to heaven unless he could be guaranteed an ample range to the west of it. Indeed, it is only by resorting to figures that one can reach a comprehension of the aggregate extent of these long, narrow, black strips of "prairie-breaking." Not until you take your pencil and run over the footings of the assessors' returns, and find that in the last year almost a million acres were added to the cultivated area of the state, do you begin to realize what the busy plows are accomplishing; and when you come to supplement this with the fact that during the same period, fully a hundred thousand people came to Kansas to make new farms and homes, you will understand how numerous, after all, must be the buildings which look so sparse to you, and so venturesome.

These buildings, by the way, are sharply characteristic, not to say anomalous,—for, really, they seem to belong to a condition of things which it is difficult to reconcile with so much of grass, and wild larks' songs, and clear blue sky. The typical log-cabin of early days on the Wabash and Sangamon is seldom to be seen here, and it is used, when you do see it, as a stable or a cow-shed; the man who made it—he of the butternut garb and the famished aspect—left Kansas when the "keers" came, and went "back to his wife's folks" east of the Mississippi. The dug-out is here, it is true; but the dug-out is an indigenous affair, and an improvement upon the ancient log contrivance in this, that it is only a make-shift, and rapidly gives way to something better. And then it is modest, also (as the swaggering old log-cabin with its clay "chinking" and its obese and ridiculous outside "chimbley" never was), and has a pleasant effect of

shying at your approach; for it is simply an opening made into a hill-side or convenient slope, you must know, roofed over with turf several layers thick on a frame-work of poles, and having a front improvised from a few chance boards and scantlings and half a dozen panes of glass. Usually, canvas or brown sheeting (a wagon-cover, perhaps) is nailed to the poles inside for a ceiling, and the walls are rendered dry and smooth with whitewash; the floor is the mere hard earth, in most cases carpeted with gunny-bags or an odd matting of braided corn-husks. They are said to be very comfortable habitations, cool in summer and warm in winter; and often these rude interiors are arranged with ingenious and admirable taste. Sometimes, too, the fronts are set off with canny little porches, to which flowering vines are trained. I once saw one that was a mass of morning-glories, through which the sunlight leisurely sought the open door and changed the gunny carpet to cloth of gold—while out upon the sod roof, a child in scant calico frock, and barefooted, stood gazing with wide eyes at a great flapping hawk overhead.

However, most of the farm dwellings for a hundred miles or farther outward are patterned after the country houses of the better styles in the older states, the predominant type being the snug white frame with green window-shutters and a gracious touch of portico. The Kansans have a phenomenal genius for homes. They reverse the old order of pioneering, and make the home the foundation, instead of the outcome, of their struggle with nature; domestic comfort and convenience are in their plan the means, and not merely the end, of life. Hence, neat and substantial houses are generally built to start with, and judging Kansas by the usual test of farm residences, you would take her to be fifty years old at least, when in truth this test of age and development here contradicts itself; often the household gods are attractively enshrined in advance of the first of the plowing.

These people, you will readily perceive, are none of your plodding, thick-witted kind, "suckled in a creed outworn." They are a new race, with a new philosophy. Enter one of their homes, and you will find a parlor with three-ply carpet on the floor, lace curtains at the windows, pictures on the walls, a shelf of books, and, not unlikely, a piano in the corner. And they will talk to you—the farmer and his wife—about Emerson and Huxley, "Deronda" and "That

Lass o' Lowrie's"; about the Centennial Exhibition, especially the part which Kansas played in it; about the new school-house, the coming election, the last evening's sunset. Then if you stay to tea (as you will be pressed to do), you will discover that the latest tricks of cookery are here also, and some more pictures, and pots of house-plants, and possibly a coy glitter of silverware. But for the big vase of wild flowers in the center of the table—daisies, larkspurs and verbenas—and the wide, ambiguous vista of untenanted prairie from the west window, you might easily convince yourself you were in New England. In fact, this very family may be from New England, since New England invented Kansas, and has sent her thousands of citizens; but, more likely, they are from some state not farther east than Ohio; the chance that they are to the manner born is only one to five. It matters little. Wherever they came from, they are Kansans now; and to be a Kansan is to have an identity at once distinct and conspicuous.

But to return to the sod. The seeding follows hard upon the plowing,—goes along with it, I may say,—and frequently you will see plows, harrows, wheat-drills and corn-planters all at work together on a single farm, where twenty-four hours before there was only a green, untrudden waste. The sod crop being often the settler's main or only reliance for the first year, and requiring but little care, the ruling idea is to get as much planted as possible. Of course, large results are not reasonably to be expected from this initial process; but ordinarily the yield is good, better than you would guess, and in some instances quite astonishing. With timely seeding and a favorable season, it is not uncommon for sod-wheat in Kansas to make fifteen bushels to the acre (above the average annual yield of the older states), and sod-corn often reaches forty bushels per acre; I passed field after field of sod-corn in the Arkansas Valley the last autumn, which I am sure would exceed that—and a considerable proportion of it, they told me, had been planted as late as the fourth week in May. There are cases, not numerous, to be sure, but none the less authentic, where these new-fashioned farmers have actually paid for their farms with the proceeds of their first crop of wheat or corn, not to speak of the three dollars per acre which the mere first plowing adds to the permanent value of the land. Then, after this sod-crop is harvested, winter

wheat may be put in these same fields—drilled in between the corn-rows, if you wish; or it may be left until spring again, and planted in corn, and then will come the richest crop that the soil is capable of producing.

Corn is king in Kansas, so far as space is concerned. They plant it by square miles, one might fairly infer, the fields are so incredibly far-reaching; and if it did not grow very much of its own accord, it could not grow at all, as the sheer abundance of it forbids anything like thorough cultivation. They aim to plow it twice, though sometimes once has to suffice, and where it has been sod-planted it is left untouched till it ripens; and yet it thrives in a way that makes folly of all rule and precedent; the stalks attain a size and height which give them a resemblance to young forests of hickory, and the men with plows look lost among them; and as for the ultimate yield in ears and bushels, is it not proclaimed everywhere in those graphic and seductive land advertisements which tell how Kansas was ten years ago the twenty-fourth state in the production of corn, and is now surpassed by only three of all the thirty-eight? The small cost and labor of tilling is doubtless the chief inciting cause of this extensive recourse to a crop which, however bounteous it may be, offers but slender profit unless fed to live stock; but I suspect it is a crop that also has special favor with frontier people—perhaps without their exactly realizing the preference—because of the resolute, imperious, army-with-banners method it has of possessing and holding the country. For corn is by nature aggressive and determined. The smaller grains feel their way timidly in a primitive soil, and the aboriginal verdure disputes every inch of progress with them. But where this autocrat of the cereals takes root it scorns rivalry, and its sway is complete and enduring. And so these leagues upon leagues of Kansas corn, seen in the summer and in their glory of silked and tasseled and sunlit strength, convey a signally striking impression. They do not merely cling to the earth, but they seize it and make it their own; you know that those dense and advancing ranks can never be stayed, never turned back; and somehow the vast expanse of unconquered prairie yet spread out before them and all about them—ten acres to each one acre of theirs—seems overawed and contracted by their masterful influence. It is Birnam: wood come to Dunsinane.

The business of wheat-culture in Kansas is of leading importance, also, and especially picturesque. In the exclusive wheat districts, there are no fences, and the different fields are divided only by wagon trails or little belts of furrowed earth similar to the border-lines of a map; and the fields embrace many hundreds, frequently more than a thousand, of acres, whole townships at times looking to be single farms. Standing in June upon a spot of elevated prairie near Abilene, for instance, you can view a tawny zone of waving, swaying wheat, five miles in breadth and over thirty miles long, with the Kansas River running midway through it (more like a shadow than a reality), and the incalculable uplands rising from it on either side, and falling away in gentle swells and curves to the distant horizon. The immensity of it, the strange billowy motion, the sorcery of color which designates the various stages of ripening, go to the making of a scene not easily forgotten. And less than fifteen years ago this was all a desolate and unblest extent of buffalo-grass, set down by the ironical geographers as a desert. It seems past belief; and yet the yellow, flexuous wonder is duplicated again and again, with slightly varying circumstances, through twenty counties, and compasses at last an aggregate of about two million acres.

The harvesting of these extensive areas of wheat presents a picture of unique and fascinating interest. The pastoral old "cradling" process is here superseded by an epic; the plentiful reaping-machines, with their glare of paint and burnished steel and their great overwhelming "reels," have a kind of Homeric character. There are probably a score of these machines in sight at one time; first the ordinary, original reaper, which leaves the wheat lying behind it in a swath, like mown hay; next the self-raker, which drops it in convenient little bunches, ready for binding; then the header, which clips off only the tips of the stems, emptying them into a large, uncouth box on an attendant wagon; and finally the self-binder, that perfection of farm machinery, that ghostly marvel of a thing, with the single sinister arm, tossing the finished sheaves from it in such a nervous, spiteful, feminine style. (I wonder what Solomon would have thought of the self-binder?) How rapidly and how deftly the keen sickles cut their way, and what straight, smooth openings they effect through the close and clinging stalks! Everywhere is eagerness, energy, urgent action,

for time is precious and foul weather may intervene; but how methodical it all is, nevertheless, and how small is the measure of wasted power! Each stroke counts; each step is a triumph. The fields change like shiftings of scenery in a pantomime. There are unexpected new lights and shades; boundary lines are abruptly transposed and confused; the landscape is momentarily made alien. Among the glistening stubble rise numberless shocks and bulging stacks; a steam threshing-machine is suddenly disclosed, half hidden in profuse and buoyant flakes of straw; and, if you look closely, you will discover that plowing and harrowing for another crop have begun in places where the harvesting is barely completed.

Those singular huts, made of rough pine boards, with canvas awnings, which you notice now and then, were set up yesterday, perhaps, and will be taken down to-morrow. They are the quarters of the men engaged in the harvesting, and very odd places they are, with their rude beds of straw, their long, narrow dining-tables, their clatter of dishes, their ludicrous mimicry of towels, combs, and looking-glasses. The harvesters out here, you soon learn, go in squads or companies, carrying their camp equipage with them from place to place, and boarding and lodging themselves. The owner of the wheat simply pays a stipulated price per acre for the harvesting, and is relieved of all the vexation and inconvenience of that sorest test of agricultural piety, the hiring and taking care of harvest hands. In many cases, he does not reside upon the land at all, but has his home in the adjacent town, where he probably also operates a grain-elevator, or holds a county office. The threshing is largely done upon the same plan, and sometimes the plowing and seeding as well. The smaller farmers secure all these advantages readily by clubbing together; so that only those who are remote from the settlements need to own reaping-machines or to do their own harvesting. Thus, one chief branch of farming—and the most remunerative one, when well managed—is shorn of the worst of its traditional toil and difficulty, and the result is seen in the significant fact that, in the last three years, Kansas has progressed from the eighth rank to the very foremost one, as a wheat-producing state, her crop for 1878 exceeding thirty millions of bushels, or about one-twelfth of all the wheat raised in the United States.

One noticeable feature of the wheat districts—the discarding of fences, namely—

is prevalent in most of the new counties, and not a few of the older ones, also, each county being authorized, by an act of the legislature, to settle the matter for itself. Upon the score of economy, the plan is manifestly a good one (statistics show that the cost of fences always exceeds the value of the live stock fenced against); and in the matter of appearance, a fenceless farm has much to commend it over a fenced one. Certainly, an utter absence of fencing is preferable to the staked-and-ridered rail absurdity which disfigures the natural scenery of some states, or to the insidious barbed-wire affair which a blunted public conscience permits in other localities. A neighborhood of farms divided from each other merely by a system of right-angled road-ways has a cheerful, confident, and hospitable look, and gives an impression that the people must be on cordial and trusting terms; where everything is left out-of-doors, as it were, suspicion of one's neighbors becomes a sort of self-reproach. There is a leaven of genuine, unspoiled veracity in such an outright renunciation of the main artifice by which man ordinarily asserts his sway over the earth; and it goes without saying that a people cannot be lacking in self-respect who keep their hogs from running at large. I am not sure but this fence question has a rudimentary relation to human nature, like original sin. They think so in Kansas, at least, where they will tell you that man is born either for or against the herd-law.

It was reserved for a quaint and unimaginative class of settlers from over the sea—the Russian Mennonites—to supplement the herd-law in Kansas with still another picturesque and excellent thing, to wit: the farm village,—an expedient by which the farmer secures all the benefits of society without sacrificing any of the utilities of life in the country. The Mennonite village is simply a single long, straight street, with houses on one side of it, twenty to sixty rods apart, and farms radiating from it in all directions; instead of twenty families (or more, as it may happen) who own twenty adjoining subdivisions of land living upon twenty aloof and separate estates, they establish their homes in a cluster at the center of the entire tract, where they have also a church, a school-house, a post-office, a blacksmith's shop, and sometimes a store and a grain warehouse. The buildings are, as a rule, of almost uniform size and appearance. The sides rise slopingly from the earth, like a wedge-tent, and are thatched with hay; the

ends are about eight feet high, and of home-made black bricks; in the middle of the room is a curiously swelled and tapered brick furnace, for heating purposes, in which straw is used for fuel; in the rear, a door opens into the stable where the cows and horses are kept. The church and the school-house, and perhaps the residence of the "head man" of the community, are in imitation of the usual Kansas framed pattern, and made of pine, accented at times by a coat of red paint, with a modulation of deep green for the solid board window-shutters. Each dwelling has its liberal front yard facing the street, encircled by young trees, and filled with primeval and flashy flowers; and not far off is the inevitable water-melon patch; for next, perhaps, to its unquestioning faith in baptism, the Mennonite heart hugs the water-melon above all things. The names of the villages, unlike the hap-hazard nomenclature of American towns, always have some distinct and suggestive meaning, as Ganadenau (place of grace), Bruderthal (vale of brothers), Hoffnungsthal (vale of hope), and so on; Hoffnungsthal, by a touching appropriateness, designates the homes of the poorest of the colonists. There are ten thousand of the Mennonites in Kansas, and they own in all a hundred and fifty thousand acres of land; so you come upon these fantastic villages quite frequently in traveling over the new counties. The architecture is gradually improving, too, as the latter-day devices of carpentry are slowly learned and accepted; and in course of time, no doubt, the houses will all be as big and snug as the "head man's"; and new stables will be built, a little farther away from the family parlor; and the front yards will become bright plots of blue-grass, with here and there an ever-green; and over the long, broad street, now so raw and so practical, the cotton-woods, growing in a thrifty row outside the gates, will throw a grateful and inviting shade.

As a contrast to the Mennonite village, nothing could be more marked than the random cabins of the "homesteaders." Miles apart they frequently are, as if trying to avoid one another; but in the aggregate there are very many of them (two thousand or more of them must have been built in Kansas during the last year alone), and they represent what is perhaps the most vivid and eventful, though the most fleeting, phase of Kansas farming. The homesteaders, you are to understand, are the pioneers of slender means, taking advantage of the beneficent law which gives a man (or

woman, if she be the head of a family) a home upon the public domain at the simple price of occupying and cultivating it for a term of years—and meanwhile it cannot be taken from him for any outstanding debts. The majority of them were soldiers during the late war, and they are therefore brave, self-reliant and fertile in expedients; and they have, besides, that gift of good spirits which is more than gold in any scheme of life. Their farms are small, comparatively speaking, and their homes too often mere places to eat and sleep; they have but few farming tools, and those of the rudest kinds; and in many cases their household furniture is entirely of their own clumsy manufacture. But they neither croak nor mope. They will all tell you they are "making it" steadily and surely; and some of their stories of what "making it" signifies out here are richly curious and impressive. One in particular I recall, which may fitly stand, in all essential respects, for the general average of them. It was related to me last October, in a cheery, half jocular mood, as I sat at dinner in the cabin of the narrator of it, a man who had carried a musket at Shiloh and Chickamauga, and been a color-bearer in the achievement of that milky-way of fame, Sherman's march from Atlanta to the sea.

"When I settled on my claim, three year ago last spring," the homesteader began, "and got the shanty built, I had just eight dollars and sixty cents left, and a sack o' flour; that was all, except a few dried apples Sarah had brought in the box with the dishes and bed-covers. We had no stove, and so we dug a hole in the ground to cook in; we hadn't any bedstead either, and I fixed up some bunks out of barrel staves, like we used to do in the army, you know. Our nighest neighbor then was four mile off; when it was cloudy we couldn't see the house at all. We got along, though, and I broke twenty acres of sod and planted it in corn and garden-stuff. Then we had to wait for things to grow. The commissary stores dwindled mighty low toward the last, I tell you, but we stuck it out one way an' another till the lettuce and the first onions come—and one day I shot an antelope: I don't believe fresh meat ever tasted better than that did, not exceptin' secesh chickens. Then, finally, the roasin' ears got fit to pull, and when the corn hardened a little more, we grated it off on an old saw we had, and that way made meal. And all the time we'd be plannin' what we'd do next year. I think that helped a good deal

to keep us in heart; it's a lucky knack in anybody; when a man quits lookin' ahead I wouldn't give shucks for him. *We* didn't weaken once, did we, Sarah?"

"No, Dick," answered the wife,—a bright-eyed little body, with a flush of rose in her tanned cheeks,—“we didn't, not even when your tobacco gave out;” and an insinuating smile lurked about her mouth.

“Well, that *was* tough,” he returned; “if anything will make a man lose his gripe, it's takin' his tobacco away from him. But we had the fiddle left, Sarah. You wont believe it, sir, but actually I used to sit out on the grass in the moonlight, and play that fiddle for hours at a stretch,—dancin' tunes, mind you,—and I know it made me feel good, and made Sarah feel good, too, and the children. It don't take so everlastin' much to make folks feel good as you might s'pose.”

“Did your crop turn out well?” I inquired.

“Tiptop, for sod-corn. That was what carried us through the winter,—a friendly, open winter it was,—and the next spring I dickered for a cow and some shoats, and bought me a sulky-plow, and put in forty acres of corn; and that year's crop set me square on my feet. Since then, we've made it right along. Last year, I had twelve hundred bushels of corn to sell, and two steers, besides pork enough to pay for our winter's groceries. I count myself worth to-day at least two thousand dollars, with a good prospect; and this in less than four year, with next to nothin' for a start. But a man ought to have as much as three hundred dollars to begin with on a homestead claim; then he's all right, and he can make it every time, if he's got the sand to stick to it, and aint lazy. The worst of it, though, is the bein' so cut off from other folks. 'Taint nigh so bad now as it used to be, settlers are comin' on so much faster. It's wearin' on women, 'specially; men don't mind it so much after a while; but women—women are queer, you know.”

“And do *you* still long for the old life back in Ohio?” I said, turning to the wife.

“No,” she replied, with a shade of pathos in her face and in her voice,—“no, not now—not since the baby died, and we buried it out there in the garden. That was the sorriest time of all. The grave was so little and pitiful, and the prairie widened out from it so far; I hadn't ever mistrusted before how big the prairie was. And it seemed wicked like, too, not to have any

funeral. But after it was all over, I felt more settled and at home, you may say, and since that I've never once thought I'd care to live anywhere else in the world.” She paused in a meditative way, and presently she added: “I'm always glad, though, when the grass comes in the spring to cover up the grave and make it look less like it did that winter day of the buryin'.”

An entirely new and noteworthy phase has been recently given to homestead settlement in Kansas by the exodus of freedmen from the Southern states. The colored homesteaders, unlike their white congeners, seem averse to the remote and single-handed theory of farm-making,—perhaps from a lack of individuality of character, perhaps because the stress of necessity teaches them a laudable caution; and so you will find them located in little clusters of a dozen or more families, and sharing the use of one another's houses, teams and farming utensils. Sometimes there will be but one span of horses or yoke of oxen, and only one plow and one harrow, in the neighborhood, owned in common, usually, and employed a day at a time by different members of the community. Such a system of agriculture has evident and serious drawbacks; but the personal spirit of it is admirable and characteristic, and goes to show that all the weight and bitterness of slavery was not equal to crushing out, but more likely increased, the mutual sympathy and brotherly kindness of the enslaved. Their dwellings, as a rule, are of the rudest construction, mere eruptions of miscellaneous boards, most of them without floors or windows, and seamed with glaring cracks; but you will also see now and then a comfortable cabin of stone, with paneled door, some fruit-trees in the yard, and a tender attempt at hollyhocks and cypress-vines; and you cannot help hoping and reasoning that these occasional cabins indicate triumphs of toil and fortitude possible to the humblest who dwell in sight of them. For obvious reasons, the “claims” are small, few of them exceeding forty acres; the freedman, however, betrays little ambition for a big farm, even under favorable circumstances, and appears mainly anxious to make sure only of so much land as he can till with his own hands. To get a home, however simple, which he can call his own, and to secure a living for himself and family, fills his conception of ultimate jubilee.

For a people whose lives have been so bankrupt in domestic ties and opportunities,

these colored emigrants are wonderfully tenacious of the idea of home and ownership of the soil. It is not too much to assert, I think, that the real guiding motive of the exodus lies in this strong desire to achieve homes: it is as though a deep and masterful instinct of the race, repressed by long-continued and compulsory gypsying, had suddenly re-asserted itself with the force of inspiration. They will tell you moving stories, to be sure, of political and physical oppression endured at the South since the war, and some among them will declare with set teeth that they came North solely to escape these perils. But you will find the large majority of them saying that the one supreme cause of their migration is this consuming aspiration for a home, and a little patch of ground, with a chance to earn food and clothing, and educate their children; and this, they have come to believe, can easiest and most surely be reached where there are public lands, free schools, and a moral atmosphere, untainted by lingering influences of the old slave days. Their preference for Kansas over other Northern states appears to be very much a matter of sentiment, though possibly a species of introspective advertising peculiar to this best-advertised state in the Union has had some effect also. They recollect that Kansas was the home of John Brown, and that makes it consecrated territory to them, for the freedmen reverence the memory of the grim and spectral old captain above that of any other man in history, not excepting Lincoln; and so when they turn their faces northward, they seek Kansas through a feeling which to susceptible and imaginative minds like theirs is in some sense a superstition.

There are now (October, 1879) probably ten thousand of these people in Kansas, three-fourths of whom arrived during the past twelve months. They have made half a dozen or more settlements in as many of the frontier counties, and have procured and begun to improve three or four thousand acres of land; and all things considered, they have perhaps done as well so far as could have been reasonably anticipated. The climate, soil, crops and mode of life are all new to them; but they adapt themselves to their novel environment with less difficulty than one would suppose, and few of them manifest any disposition to retrace their steps. The exodus, however, is still an unsolved problem. It yet remains to be proved if this singular and pathetic

movement has in it enough of logic, and courage, and patience, and the enthusiasm of common sense, to make it a success. The burdens and sacrifices of founding homes in a new country, even on the part of those to such manner born and bred, have ever been heavy and exhausting, and these unaccustomed pilgrims must, from the nature of the case, expect to meet more than the usual obstacles. The result will depend, after all, upon themselves. Their chief hindrance, their irony of fortune, so to speak, is their general and extreme poverty. But poverty can be overcome, we know, by hard work and frugality; and it will not do for us to say that the freedman should stay away from a new country merely because he is poor; for it is by going to a new country that the poor man better his condition, and the homestead law was made for such as he. Neither will it do to draw a distinction of color against him, and warn him back because white men alone have heretofore subdued the frontier, lest he challenge the soundness of our laws, the sincerity of our religion,—or lest he turn upon us, as one of them was recently moved to do, with the half-mournful and half-scornful retort: "I am my old master's own son, sir!"

Next to calamities like that the homesteader's wife told of, the great besetting fear of the settlers on the border—in all the new and thinly peopled portions of Kansas, in fact—is the coming of the autumn prairie fire, which so frequently menaces their stacks and cribs, their helpless stock, their stables and cabins, and even their lives. Were it not for its known danger and power of havoc, this tempest and scourge of fire would be a spectacle of commanding force and beauty. First, you will catch glimpses of what you take to be gray wisps of haze away off on the horizon; and watching, you will see these vagrant particles deepen gradually, and gather into a definite volume of smoke, black like a rain-cloud, and bronze about the edges. Then the strange, somber bulk starts forward across the prairie, and you hold your breath at sight of the rapid progress of it. (A mile in two minutes is not an exceptional rate of speed for a fire once fairly under way.) It halts an instant you note, over a broad swale where there is standing water; but it is for an instant only. The next moment it reaches the upland again and the dry grass; and directly it grasps a belt of the tall, thick blue-stem, and the flame leaps suddenly and madly out

above the smoke, then subsides again, and the black mass grows blacker than ever, and rolls higher and higher, and you can scent the burning grass, and hear the distant roar of the fire—an awful roar, resembling the sound of artillery in heavy timber. And it is so calm immediately about you that you do not so much as miss the ticking of your watch in your pocket; there is no breath of air stirring, and the sun is shining, and the heavens above you are blue and placid. But the stillness will be broken soon. The oncoming cloud is only a few miles away now, and you easily trace the scarlet and terrific energy at its base; the smoke begins to hurt your eyes, too, and the heat becomes heavily oppressive. And then, all at once, the wind smites and staggers you, that appalling roar deafens you, and the sun is blotted out, and you are in a darkness as of a midnight without moon or star. It is an experience of but a dozen seconds or so, this sudden plunge into darkness, though it seems an hour, and when you look out again, you find that the fire has passed you a mile or more to your right, and is still rolling desperately onward; and there in its track are charred and smoldering stacks of hay, and an occasional house aflame and tottering to its fall, and a group of men and boys beating back the outer line of the fire with brush and old clothes, and sending forward little counter-fires to meet it and if possible keep it at a safe distance. The creek may stop it and smother it when it gets there, though such a hope has mere chance for a warrant: sometimes these mighty conflagrations vault across streams twenty or thirty yards in width, so swift and resistless is their momentum; and as a rule they are effectually stayed only when they reach a wide extent of plowed land, and have to yield, sullenly, for lack of anything more to feed their inexorable fury.

In journeying on westward, past the farthest of the homesteaders, and the last of the surveyors, out of sight of the uttermost tokens of civilization, you will see the trampled and dingy places where many of these dismaying fires have their origin—transient camps of hunters or scouting soldiers, or miners going overland to the mountains. You will also find at intervals the ruins of an old fort or stockade to remind you of the Indian days; you will stumble upon numerous towns of the prairie-dogs, and put your vanity as a sportsman to shame with your impotent

attempts at shooting the absurd little creatures; you will be kept awake at night, and made afraid in spite of yourself, by the sharp, gaunt cry of the coyote; and then, finally you will come to the cattle-ranches, and the great herds lazily grazing on the level, hushed, and still interminable empire of prairie.

The ranch usually includes a dug-out for the herdsmen, a corral, into which the cattle may be driven, and a few awkward hitching-posts, or stakes for lariats. It is not an inviting place, and yet the first sight of it thrills you pleasantly; it is a hint of life, at least, and the presence of man, in the heart of this vast, enveloping stillness. For you can have no just sense of what solitude is, and remoteness, and height of sky, until you visit these frontier cattle-pastures. But for this accidental ranch, with its timid curl of smoke, its surrounding litter of cards, bottles and tin-cans, and the trail leading out from the corral to the grazing grounds, you would be tempted to think the cattle a part of the dreamy landscape, they blend so readily, a few miles off, with the verdure and the shadows. Nor do they quite forfeit their look of integrant relation to the scene when you draw near enough to view them distinctly. They are very different from the herds which you saw back in the settlements, and to which you have been all your life accustomed; these broad horns, thin nostrils and trim, sleek limbs came over from Spain with Cortez in 1510, more than a hundred years before the good ship *Charity* brought the first neat cattle to New England. And is this New Spain, then? Once it was, yes, and the cattle of the time are here yet to recall the vanished and well-nigh forgotten glory of Spanish conquest in America; even the herdsmen pay unconscious tribute to this aspect of the picture by arraying themselves in the old Castilian sombreros, and open-legged trowsers with rows of buttons, and jackets gaudy with many-colored braid and Indian beads, and now and then a blood-red scarf like a matador's. But presently your ear catches the ornate and nimble blasphemies of these make-believe Spaniards—and then you know you are yet in Kansas. You heard and remarked that same peculiar picturesque form of profanity the morning you crossed the Missouri River at Atchison, and afterward, often and plentifully, among the wheat-harvesters, the teamsters hauling corn to Wichita, and the horse-traders plying their dexterous art at

Ganadenau. The faces are unmistakable Kansas faces, too, when you come to scan them closely; and the talk around the ranch, in the mellow evening, with the moon transfiguring everything after the fashion of the mirage, is all of Kansas affairs and Kansas people, ranging by easy gradations from the governor's chances for the senatorship down to the idle gossip about some pertipped village Rosalind.

Thus the sunburnt and isolated herdsman, flourishing his lasso out upon the very rim of the scene, is still a congenerous character,—“one of our things,” as the Kansans have a habit of saying,—and serves in his way to complete and connect the various scattered signs of that common impulse which shapes and impels the life of the state. And what a throbbing, hastening, fluctuating life it is! and yet how each separate phase of it, the crude as well as the matured, fits into the general plan with unerring accuracy; not even the morning-glories on the dug-out porch could be spared, nor the baby's grave in the homesteader's garden.

To-day here becomes to-morrow as if by a miracle; prophecy is so swiftly succeeded by fulfillment that the two may almost be said to move hand in hand together. The railroad creates traffic instead of being created by it; farms are multiplied with a rapidity that confounds reckoning; the school-master and the minister, the milliner and the music-teacher, come in with the first crop; the newspaper is printed under a tree while the town-site is being staked off. A period of less than fifteen years (the present Kansas dates only from 1865) has sufficed to pro-

duce results which formerly required half a century of toil and trial and waiting. In the last year alone, nearly six hundred and sixty-seven thousand acres of wild land were redeemed and made productive in the single matter of wheat—a fact without parallel; and it is estimated that not less than fifteen thousand dwellings were erected by new settlers: certainly there were three hundred and fifty-four school-houses built during the year, at a cost of two hundred thousand dollars, for the official records avouch it, while also showing that the total expenditures of the year for public schools were a million and a half of dollars; and the present number of churches in Kansas, in proportion to population, is larger than can be claimed by any other state of the Union.

What more remains to be said? Nothing; everything. Kansas is yet in the sunrise and the spring-time of her development. The marvelous exhibit of the past fifteen years is but the prologue to the swelling theme. Only a trifle above one-seventh of the state is under cultivation; there are still over forty millions of tillable acres to be transformed into farms; and the alert and potent influences that have already done so much are in no danger of exhaustion. This strange intense life which has given a quickened impetus, an enlarged and propitious meaning, to the national talent for immigration is not a mere spasm. It comes nearer to marking an epoch of civilization. It is the new crowding out the old; it is progress declaring afresh that the earth is man's, and the fullness thereof. And may we not say there is destiny in it? Or shall we salute it by a better name, and call it Providence?

ODE TO DROWSINESS.

BREATHER of honeyed breath upon my face!
 Teller of balmy tales! weaver of dreams!
 Sweet conjurer of palpitating gleams,
 And peopled shadows trooping into place
 In purple streams,
 Between the drooped lid and the drowsy eye!
 Moth-winged seducer, dusky soft, and brown,
 Of bubble gifts and bodiless minstrelsy
 Lavish enough! Of Rest the restful crown!
 At whose behest are closed the lips that sigh,
 And weary heads lie down.

Thee, nodding Spirit! Magic comforter!
 Thee with faint mouth half speechless I invoke,—
 And straight up-looms through the dead centuries' smoke
 The aged Druid in his robe of fur,
 Beneath the oak
 Where hang uncut the paly mistletoes:

* * * * *

The mistletoe is changed to Indian willow,
 Glassing its red stems in the stream that flows
 Through the broad interval; a lazy billow,
 Flung from my oar, lifts the long grass that grows
 To be the Naiad's pillow:

The startled meadow-hen floats off, to sink
 Into remoter shades and ferny glooms;
 The great bees drone about the thick pea-blooms;
 The linkéd bubblings of the bobolink,
 With warm perfumes
 From the broad-flowered wild parsnip, drown my brain;
 The grakles bicker in the alder boughs;
 The grasshoppers pipe out their thin refrain
 That with intenser heat the noon endows;—
 Then thy weft weakens, and I wake again
 Out of my dreamful drowse.

Ah! Fetch thy poppy-baths, juices exprest
 In fervid sunshine, where the Javan palm
 Stirs scarce awakened from its odorous calm
 By the enervate wind that sinks to rest
 Amid the balm
 And sultry silence, murmuring, half asleep,
 Cool fragments of the Ocean's foamy roar,
 And of the surge's mighty sobs that keep
 Forever yearning up the golden shore,
 Mingled with songs of Nereids that leap
 Where the curled crests down-pour.

Who sips thy wine may float in Baiaë's skies,
 Or flushed Maggiore's ripples, mindless made
 Of storming troubles hard to be allayed.
 Who eats thy berries, for his ears and eyes
 May vineyard shade
 Melt with soft Tuscan, glow with arms and lips
 Cream-white and crimson, making mock at Reason:—
 Thy balm on brows by care uneaten drips,—
 I have thy favors, but I fear thy treason;
 Fain would I hold thee by the dusk wing-tips,
 Against a grievous season.

TOPICS OF THE TIME.

"The Reign of Peter the Great."

AN INTERESTING ENTERPRISE.

It is a curious fact that literary men, in search of material upon which to exercise their gifts and with which to associate their names and reputations, should, for so long a time, have passed by untouched one of the most important and dramatic careers that have ever entered into the records of history. Mr. Bancroft chose to present the annals of his own country, Mr. Prescott to paint the beginnings of civilization in Mexico and still more southern regions, and Mr. Motley to write of Holland, though his brief monogram on "Peter the Great" shows how much he was attracted to that theme. A thousand times, probably, in this country and England, the life of Peter the Great has presented itself to the ambitious historian as a theme quite worthy of his pen,—perhaps as the most attractive theme left unworked; but great difficulties confronted all born out of Russia who should undertake its elaborate treatment. The difficulties of distance and of language were so nearly insuperable, that all have turned to easier fields; and it has been left to Mr. Eugene Schuyler to undertake the history of one of the most remarkable personages of modern times.

Peter the Great was the father of an empire. Whatever of true greatness Russia possesses, she owes more to him than to any other man. Coming to his throne as a child, imperfectly educated as a young man, marrying at the age of seventeen, he found, at length, that he needed to learn the art of government. He entered the army and served through all grades, that he might learn how to reorganize it. Finding his country without a navy, he became a practical seaman and ship-builder, living for months in hired service and in disguise. Seeing that his nation was half savage, and that it was not in communication, on even terms, with other nations, he traveled and came into contact with more polite civilizations. He studied, attended lectures, and cultivated himself in all possible directions, sent youth out of his country to be educated among the western peoples of Europe, and introduced such reforms among his subjects, and so added by conquest to his territory and possessions, that when he passed his government into the hands of his Queen he left a strong and comparatively homogeneous people and a powerful throne, in place of the heterogeneous mob and divided and childish power which he found, or which rather found him, on his elevation to the sovereignty.

The opening period of Peter's reign was one of great disturbances among the people. The chapters in which Mr. Schuyler tells the story of these disturbances read more like the records of a wild imagination than those of sober history. The superstitions associated with Christianity, the murders instigated by party spirit as between the two orthodoxies,—the old and the new,—the court and class

intrigues,—all these, acting and reacting upon a common people, equally ignorant, fanatical, and brutal, make up a mass of details of tremendous interest, and of a character almost or quite unexampled.

Well, it is proposed to publish throughout a period of two years the history of this man's eventful reign, and a detailed account of the events of his personal life. We have entered upon this great enterprise, believing that no novel can be half so interesting to our readers as this unique book, though we expect to keep up the usual supply of serial fiction of the best character. We expect, by establishing bureaus of illustration in Paris and St. Petersburg,—the city which Peter himself founded as one of the most brilliant and permanent records of his great career,—to secure for illustrations copies of a great number of historical pictures of the highest character. These, to which we have full access, will be more dignified and valuable than any designed by less skillful masters for a temporary purpose through lighter inspirations.

We have sought the world over for the best thing we could find with which to please and benefit our constantly increasing army of readers, and here it is. It has been purchased, literally, without regard to cost, and is presented as the best achievement of our enterprise. The first installment will appear in our January number, and the work will be continued from that number until its completion. We do not know of any intelligent American who can afford to be without SCRIBNER'S MONTHLY until "The Reign of Peter the Great" shall be completed, and we do not intend that he shall afford to be without it then.

"Is Life Worth Living?"

MR. CURTIS once asked Mr. Greeley, in response to a similar question put to him by the great editor, "How do you know, Mr. Greeley, when you have succeeded in a public address?" Mr. Greeley, not averse to the perpetration of a joke at his own expense, replied: "When more stay in than go out." Mr. Mallock's famous question, answered by himself in a weak way, and repeated by Professor Mivart, and answered in a stronger way, is practically voted on every day, by the entire human race, and decided in the affirmative. "More stay in than go out," for reasons very much less important than those considered by Mr. Mallock and Professor Mivart. There are great multitudes of men who possess neither the Roman Catholic faith nor rightness of life nor love, who yet live out their lives in the firm conviction that it pays them to live—men who are open to no high considerations, such as would have weight with the Mallocks and Mivarts.

There is a great pleasure in conscious being. So universal is this that, when a man occasionally takes his life, it is considered by those whom he leaves behind him as presumptive proof that he is insane.

We say of a man who designedly ends his life that he is not in his right mind. One of the most pathetic things about death is the bidding good-bye to a body that has been the nursery and home of the spirit which it has charmed through the ministry of so many senses.

"For who, to dumb forgetfulness a prey,
This pleasing, anxious being e'er resigned,
Left the warm precincts of the cheerful day,
Nor cast one longing, lingering look behind?"

Men find their pay for living in various ways. Hope may lie to them, but they always believe her, nevertheless. The better things to come, of which she tells all men, become, indeed, the substance of the things desired; that is, expectation is a constant joy and inspiration. The pay for this day's trouble and toil is in the reward which is expected to-morrow. That reward may never come, but the hope remains; and so long as that lives, it pays to live. It pays some men to live, that they may make money, and command the power that money brings. To what enormous toils and sacrifices the love and pursuit of money urge a great multitude of men! The judgment of these men as to whether life is worth living is not to be taken at life's close, when they sum up their possessions and what they have cost, but while they are living and acting. A man whose life is exhausted may well conclude that what he has won is vanity; but it was not vanity to him while he was winning it, and, in the full possession of his powers, he believed that life was worth living.

Who shall estimate the inestimable? Who shall weigh the value of the loves of life? There are very few who do not see a time in life when all their trials would be considered a cheap price to pay for the love they exercise and possess. The lover who wins and possesses his mistress, and the mother who carries a man-child upon her bosom, drink of a cup so full and so delicious that, whatever may be the ills of life, they sink into insignificance by its side. A single year of a great satisfying love spreads its charm over all the period that follows, and often sweetens a whole life. We have said that there is great pleasure in conscious being, and the statement covers more ground than at first view appears, for all pleasures are simply augmentations of the consciousness of being. The pleasure that comes of wine is of this character—it raises and intensifies the consciousness of being, and makes the treasure of life itself for the moment more abundant. It is so not only with all sensual delights, but with all mental and spiritual pleasures. They stimulate and enlarge the sense of life,—the consciousness of living existence,—conferring upon it only new forms and flavors.

The pursuit of money is only one of the pursuits of life. Fame, power, literary achievement, art in a hundred forms, social eminence—all these and more are objects of pursuit, so absorbing and delightful that men find abundant reward in them. Life is quite worth living to all those who find engaging objects of pursuit, and especially to those who win success in their pursuits. We repeat,

therefore, that, by almost a unanimous vote, the human race practically decides every day that life is worth living. Mr. Mallock thinks it is worth living provided a man has faith in a great church; and Professor Mivart—a Catholic himself—thinks life's highest values are in the doing of duty and in love. We should be the last to claim that happiness is the highest aim of life, and that, unless that is secured, life is a failure, and not worth living. To do right, to sacrifice one's self for love—these are better things than pleasure. To love and to be loved—these are things that pay. To be conscious of nobility of character and unselfishness of life; to be conscious that our lives are brought into affectionate relations with other and harmonious life—what are these but life's highest values? What are these but the highest satisfactions of conscious being?

If this be true,—that character and duty and love are better than pleasure and better than any success without them,—then there is no human being who needs to say that life is not worth living. But the people who do not succeed, who are unloved, who live lives of pain and want and weakness—what is there for these? A chance for conscious nobility of character and life; and if this be not enough, as it rarely is, a faith, not in a great church, but in a good God, and an immortality that will right the wrongs and heal the evils of the present life, and round into completeness and symmetry its imperfections and deformities. Is it not foolish, after all, to raise the question of success or failure in treating a life that is only germinal or fractional?

The Nation's Doctors.

WHEN a patient is convalescent, we discharge the doctor. When the processes of nature are building up the wasted frame, and re-enforcing the vital power, we bid good-bye to pill, powder, and plaster. We eat, sleep, and exercise and grow strong, and the fact that we grow strong is taken as proof positive that nature is enough for all our wants, and that any interference of the doctor is not only superfluous but dangerous. We suppose nothing can be more certain, or more apparent, than that the American nation, so long sick and feeble in its material interests, is convalescent. Our paper lie has become an honest dollar. Our exports exceed our imports. We have great crops of the essential supplies of human life, which the world wants, and is willing to pay for. Our manufactures are slowly winning back prosperity to themselves. There is increasing demand for labor, and the number of the unemployed is growing less every day. Indeed, we seem to be in a very fair way to prosperity, with only one danger that menaces us,—namely, Congress, and its little army of political doctors.

Strange as it may appear to people of common sense and common political observation, there are still those in the country who think that there can be something better than an honest dollar. Against the judgment of the whole practical world of finance, they would, even now, interfere with the healthy progress of the country toward recovery, by tinkering

ing the currency. To them, the resumption of specie payments is a grievance; and they desire to go back to the time when a dollar was not a dollar, when money was cheap, and the commodities of life were dear. Even the "fiat money men" still live—the most idiotic of all the financial doctors. All, or most, of the schemes of these men are for the benefit of "the debtor class." Practically, they demand that poor money be furnished to pay debts with. Practically, too, they demand that, solely for the benefit of the debtor class, the currency shall be degraded, and the finances of the country disturbed, and chaos again introduced into the nation's business. The schemes of these men cannot be stated in any way that is not disgraceful to the schemes themselves and to their authors. They demand a cheap and degraded dollar to pay debts with. They do not even pretend that it will buy what an honest dollar will buy, because they know better. Of course, the only apology for this rascally looking plan is found in the fact that the debtor class became debtors when money was degraded, and that they ought to be allowed to pay in the same kind of money. Whatever of seeming justice there may be in this plea, it is a sufficient answer that no class has a right to degrade a nation's money, or upturn the only sound basis of currency, for its own convenience. Besides, the experience of the world proves that people do not pay debts when money is cheap. That, of all times, is the one when they contract debts. Nothing can be prophesied with greater certainty than that people will run in debt when money is poor and cheap. The direct way to a great extension of credit, and the indefinite increase of the debtor class, is through an expansion of the currency. Expansion fans all schemes of speculation, stimulates the desire to live without labor, overdoes all kinds of business, and leads by the directest of roads to financial ruin. This is what all experience teaches; and it is really marvelous that men can be found who are seriously discontented with the present status. During the month of thanksgiving, it seems to us that one of

the special subjects of gratitude for which thanks should be given to Almighty God is the honest dollar which it is now our privilege to give and receive, in the interchanges of our daily business.

But our financial doctors are not the only ones whose intermeddling we have reason to fear. We have seen, during the year that is past, the operations of the party doctors, in a way to disgust all honest men. We have seen our national legislation handled with sole reference to its effect upon the power of parties. In Washington, during the past year, there has hardly been a question of any kind up for discussion and action that has not been decided by its bearing upon party politics. Republican and Democrat alike have been managing for power through legislation. We are aware that the politician laughs at all rules of action higher than his own, and regards as of small account to the country the squabbles in which he engages for supremacy; but to the great, honest, simple crowd who do the voting, their recklessness is revolting. They are patriots and not politicians, and believe there is such a thing as statesmanship, or ought to be. When Congress shall come together again, the unworthy and undignified strife to secure the next Presidency will be recommenced. The questions that will arise between the two parties will not be decided on patriotic grounds. Nobody expects it. Every question that is started in Congress will be voted on, on the two sides, with regard to the effect of the vote upon the next Presidential nominations and election. Little account will be made of the fact that the country is becoming prosperous and ought not to be meddled with. Little account will be made of the fact that we are doing well enough, and desire to be let alone. If party emergencies demand the doctoring of the national policy, it will be doctored, even if it bring a relapse. The fight between the ins and the outs is waged without scruple; and, in the meantime, if the patient is vigorous, he may live and get thoroughly well if he can, in spite of doctors who seem bent on disturbing all the natural processes of cure.

COMMUNICATIONS.

The "Infant Hercules" Again.

A REJOINER FROM THE AUTHOR OF "THE NEW MUSEUM AT ROME."

ROME, June 9th, 1879.

EDITOR OF SCRIBNER.

Dear Sir:—While admiring the ingenious and learned study of your correspondent, Mr. Henry W. Haynes, on the subject of the statue called "The Infant Hercules," engraved for my paper in the May SCRIBNER on the New Museum of Rome, I cannot agree with his conclusions in naming it "Love disguised with the attributes of Hercules."

That it is not "*Commodus* as the Infant Hercules" is true, as is evident from the text of my article.

For this I am only so far responsible that in preparing my manuscript, I neglected to write the title of each statue under the picture. However, I am glad to say something more about this charming little statue and its companion, the "Mother Earth," which were found together in the year 1872 in the beautiful cemetery of Rome called Campo Verano. Like the cemetery of Bologna, this of Rome was fixed by chance on the site of a very ancient one. These two works of art were statues of mythological deities, who were supposed to communicate with and care for the departed, to visit them in the regions whither they had gone, or to receive their bodies and their spirits for the long repose. The characters

of the "Mother Earth" and of Hercules express this longing for some news of the beloved ones laid in the cemetery. They were entrusted to the care of the "Mother Earth, of whom all were born and to whose bosom all returned," and to Hercules, who had returned unharmed from the dreaded shades.

Cupid, according to mythology, was not the god of the dead, but of the living. He danced on the earth, flew through the air, mounted on the trees, sported with gods and men, and shot the latter with golden darts. He rides upon a lion or a centaur, or is perched on the shoulders of Hercules, his dominion over all being thus symbolized. But he is never represented as visiting the domain of the dead or in connection with Pluto, or Proserpine, or Cerberus, or any of those monstrous beings or gods with whom the ancients peopled it. It is Hercules who descends to the infernal regions to bring back Alceste to her husband Admetus, for whom she had just offered her life. He defeats Cerberus, the dreadful guardian of the place, who permits him to enter, but not so easily to escape. He presents Proserpine, the queen of the infernal regions, with a golden branch. When Pluto carries off Proserpine, Hercules, covered with the skin of the Nemean lion, precedes the car. No pagan divinity is more frequently mentioned in connection with Tartarus, Hades, Hell, Erebus, Elysium—the divisions of the future world, where, according to the ancients, the good as well as the bad were gathered.

The type of Cupid was a winged infant form of soft, voluptuous grace, and even if he borrowed the club, the lion's skin, the golden apples or the serpent of Hercules, he would still retain some traces of his identity. But the figure of this child hero, "The Infant Hercules," has the strength of muscle and the masculine grace always attributed to the god of force. The neck is short, the head small, the hair short and crisp, as is usual in the statues of Hercules. The smiling face expresses strength of will superior to his age and prophetic of the great deeds afterward accomplished. The artist has perhaps attempted to show this by placing in his hand the golden apples of the Hesperides courageously won. His youth, which is not the tender grace of babyhood such as would become a Cupid, may represent the eternal youth of the blessed immortals, and he

smiles on the living to prove that although he has descended to Hades and fought with Cerberus he has returned conquering and triumphant. The bow and arrows in the quiver refer to that part of his fabled history which says that he was taught the art of shooting by the Scythians, who were skillful archers, his quiver being such as was used by that nation. I see no reason, therefore, for calling this figure a Cupid. It has no wings as a Cupid should have, and the emblems are entirely appropriate to Hercules and to the place in which the statuette was discovered.

Neither is it a Mercury, or Hermes, as is suggested by Welcker in regard to the similar statuette in the Vienna Museum, mentioned by Mr. Haynes. This god would have more affinity with a cemetery than Cupid, as he sometimes visited the infernal regions. But he would still retain, I think, some indication of his own character even under his borrowed plumes. Mercury is lithe and light of limb and carries a purse in the hand, or is furnished with wings on the feet, or on the caduceus he carries in his hand, or on his head. Often, as is seen in a statue in the New Museum, he has wings on the top of a close-fitting cap.

But the "Infant Hercules" has no wings on the little feet, or on the hands or in the hair. Suspecting that the two points on the head under the lion's skin indistinctly seen in the picture might be wings, I went over to the Museum to-day, and found that they were unmistakably the front teeth of the lion's mouth thrown over the head of the figure. These two long front teeth are seen also in the engraving of "Commodus as Hercules" in my paper on the New Museum (although one is broken off), and in the chubby green basalt Boy Hercules, found on the Aventine hill and now in the Capitoline Museum. They are generally seen also in the statues of Hercules when the lion's skin is on his head.

It has been universally agreed by the learned archæologists of Rome, that this statue is an Infant Hercules. I have here only sought to amplify that idea, and I believe I am not wrong in refusing to agree with Mr. Haynes, when he calls it "Love disguised with the attributes of Hercules."

Very truly yours,
SOFIA BOMPIANI.

HOME AND SOCIETY.

Light, Heat, and Power for the Householder.

THE demand for light, heat, and power in the household has always attracted the attention of inventors, and within the past year or two efforts have been made to bring science to the aid of the householder, to cheapen the cost and extend the application of these three domestic necessities. For the householder, the subject presents a bewildering ar-

ray of new means and new appliances, and it is worth while to consider briefly what has been done, and what seems likely to be done, in these fields of domestic economy.

LIGHT.

Light is supplied to our houses by two methods,—by burning oil or gas. Which is the better? To

understand any question of commercial values, we have to consider two elements,—the first cost, and the time and labor spent in the care of the things bought, which makes a second cost. A lamp, an oil-can, and a quart of oil cost so many cents delivered at the house. The lamp must be filled, the wick adjusted, and the lamp transported to the room where it is to burn, and this makes the second cost. Every human being's time and labor has some value. It may be low, but it is worth, at least, the cost of the food he eats. A householder who earns six dollars in a day of ten hours knows well enough that, if ten minutes a day must be spent in trimming lamps, she is out of pocket just ten cents, or sixty cents a week. In the case of gas, the fixtures and the price of the gas make the first cost; but there is practically no second cost, except the labor of lighting, which is really less than in lighting oil. On comparing these two, we find that the first cost of oil is less than gas, and the second cost more; and to get at a fair estimate of the value of each, the first and second costs must always be added together. This point is here noticed because, in examining the proposed methods of supplying our houses with light, heat, and power, these two costs will be found to vary greatly. It will be impossible to give exact figures in regard to the total values of the new sources of supply for these things, because the second cost varies with the value of the individual householder's time and labor, and each must consider the matter carefully for herself. More than this, each has a different estimate of the value of her time. A woman having a number of children to care for will object to the second cost of oil lamps; her time is too precious for such things. Another, with a small household and few duties, may wisely save the first cost of gas at the expense of the second cost of oil.

The present position of the light supply is very far from satisfactory. In the case of oil, the first cost is low, but the second cost, including the danger from explosion and fire, is very high. Candles, which are simply solidified oil, are cheaper in appearance than oil; but, measuring the total cost by the light actually given, they are much dearer. The second cost of gas is low; the first cost is very high. What, now, may we expect from these sources of supply in the future? and is there any new source? In the case of oil, there have been very great improvements in the methods of burning it; but these improvements seem now to have reached their best results, and it is doubtful if any better forms of oil lamps will be introduced. So far as human reason can estimate, the sources of oil supply are practically inexhaustible, and the price seems likely to remain low. Candles are also probably as good as they will be. Concerning gas, there is very great room for improvement in the quality of the gas, the methods of burning it, and in its price. Already, there are greatly improved methods of making it, very decided improvements are being made in the methods of burning it, and the price is falling, and likely to go very much lower. It is very doubtful if it will be supplanted by any other form of do-

mestic light at present. Its second cost is so low that it will be more and more used as the first cost is brought more and more within reasonable figures. When it is delivered at fifty cents per thousand feet, it will, in improved lamps, be used with even more freedom than now. For communities seeking a light for their town, the aim should now be to obtain the latest and most scientific methods of making gas. For the individual householder, the aim should be to find the best and most improved burners.

Perhaps there never was at any time so much scientific research, skill, and capital applied to one invention as is now being bent to the improvement and introduction of the electric light. This source of light is comparatively new, and it is still in the experimental stage. In its various forms, it is on trial in nearly all the large cities of this country and Europe, and, so far, it has given a large measure of satisfaction. Like all new things, it is changing almost weekly; new styles of lamps, new and improved methods of obtaining the light, are announced continually. For lighting streets, halls, public buildings, docks, workshops and pleasure grounds, it far exceeds gas in pliability, convenience and power. Its second cost is quite low, and its first cost is claimed to be less than gas; but concerning this, an absolute opinion cannot be given, because the experiments are incomplete. For the householder, the electric light has so far proved unavailable; but it would be presumptuous to say it will never become a domestic light. The prospect is decidedly in its favor, and its rivalry to gas seems to be merely a question of time. Its position, in spite of all its defects, is secure as a means of lighting large spaces, both without and within; and, as soon as its first cost is definitely settled, it will assume a recognized position as a source of light-supply.

HEAT.

In no other country is there to be found better or cheaper fuel than in the United States, nor do any other people employ better means of burning their fuel to advantage. Our wood and coal stoves, ranges and furnaces are the best to be found, and improvements are being made continually. The householder, looking for some one to help her in the search for cheap heat, has looked too long to the stove man, and lately she has been drawn to the oil-stove and gas-stove. The trouble with our present method of obtaining heat is not in the stove but in the fuel. The first cost of heat from coal is low, but the second cost is very high. This includes bringing the coal from the cellar to the fire, making the fire and removing the ashes. In the case of cooking,—boiling water, for instance,—the waste of time, labor and fuel in bringing the fire up to a proper heating point, and the great waste of heat, after the actual work of boiling is over, raise the cost of the heat to a most ruinous and extravagant price. Added to this is the fact that even the best stoves only use a very small percentage of the actual heating power of the coal. So wasteful and extravagant is our present system of obtaining heat, that the

attention of inventors has been drawn to the matter, and several new methods of obtaining heat for domestic purposes are now proposed. One of these new systems employs steam laid on in pipes precisely like gas or water. The householder has only to turn the valve to warm her house and assist in cooking the dinner. When she has finished she shuts off the supply and pays for only what she has used. The first cost by this method is somewhat less than when fuel is burned in the house and the second cost is very much less, as there is no coal to be carried upstairs, no dust and ashes to be removed, and no heat wasted after it has done the required work in cooking or heating. For the householder this method presents many advantages and it is already in use in several places. Next to this system is another presenting more advantages, both to the individual householder and the community, and one that seems destined to modify our whole system of domestic economy. In place of bringing coal to each house and removing tons of ashes from every door, or even of burning coal in central stations and distributing steam heat, it is proposed to turn the coal into gas outside the town, at a distance of perhaps miles, and to supply the entire town with gas-fuel laid to every man's door. In place of smoking chimneys to every house there would be only slight shafts to carry off the productions of combustions from gas cooking stoves and furnaces. This plan is already perfected, and in time it seems likely to be adopted universally. The first cost of a non-luminous gas-fuel would be less than any fuel we have, as now used, and its second cost would be less than steam. If a gas-fuel can be delivered for 20 cents per thousand feet, the question of heating and cooking is practically settled, and such a fuel would undoubtedly supplant coal in all our cities. The moment the valve is turned the fire is ready at its fullest heat. When the kettle boils, or the room is warm, the valve can be closed. There is no dust, no ashes, no waste heat. As an evidence of the great value of such a system of domestic heating it may be observed that even at the present high price of luminous gas the second cost of cooking by gas is so low that it pays to use it in every family where the time of the house-mother is worth more than the wages of an ordinary servant. It must be constantly kept in mind that it is the second cost of things like light and fuel that makes the price so high. Heating and cooking by a cheap gas-fuel is the perfection of domestic economy, and is without doubt to be the universal method in all our large towns. The prospect in this direction is most promising. A cheap gas of high heating power can be made, and when the people understand its superiority they will demand it, and the gas companies will wake up from their chronic state of inertness and give it to us.

POWER.

With the increasing education of a community comes the necessity of reducing in some way the amount of mere manual labor that must be performed in every house. Work there will be, but

who can afford to do it? Life is worth too much to drudge over a wash-board or needle. Needles and wash-boards there must be or the higher life is a failure, and machinery must take the place of hands. A motor of some kind is becoming essential to domestic happiness. There must be a wind-mill or a hydraulic engine, a gas, electric or steam motor in every house. Power cannot be easily distributed and if we must have it in every house the motor must be under the roof. Power, light and heat are convertible, and if we have one, it is easy to have the others. Heat we may have in the form of steam, and the same steam may drive an engine. Light may come from gas and the gas may also drive a gas engine, or it may come as electricity delivered by a wire, giving light by night and running a sewing machine by day.

Placed in the order of their highest cost (first and second costs) the sources of domestic power are as follows: the steam engine, gas engine, and hot-air engine. Other motors useful in certain situations are the wind engine and hydraulic engine. The steam-engine for domestic use is cheap in first cost and very expensive in second cost. No power is obtained before or after the water ceases to boil, it requires skilled attention and is dangerous and unsuited for domestic life. If the steam is bought by measure from a company the cost will be materially reduced, but not sufficiently to make it cheap. The hot-air engine is less troublesome and consequently cheaper in second cost. The gas engine is, even with the present prices of gas, the best domestic motor we have, because its second cost is so low. Full power is obtained at the start and when not in use it costs nothing. If we had cheap gas both the hot-air engine and gas motor would immediately rise in value and become most useful servants in every household. The gas motor particularly would be the one thing needed, an indispensable feature in every dwelling, to turn the wringer and washing machine, run the elevator and sewing machine, a faithful servant, silent, safe and easy to manage and costing nothing when idle. When electricity becomes a domestic light we shall have at once light and power. A slender copper wire will supply all the power demanded in an ordinary household, always ready to do any work needed; a hewer of wood and drawer of water by day, a light for the feet by night. Of the cost of this motor no figures can be given at present, but there is every reason to hope that it will be the cheapest and best form of power obtainable with the present resources at hand.

Summing up the field, we may look with confidence to the future for cheap light from gas and electricity, cheap heat from gas-fuel, and cheap power from gas-fuel and electricity.

CHARLES BARNARD.

Weaning the Baby.

"YES, I know I ought to wean her." How many mothers say this, and say it with a sad consciousness that they are neglecting a duty to themselves

and the child by putting off the evil hour,—the mother-heart shrinking from what she feels must be pain to her darling. With tender prescience she sees the week of weeping and baby agony she will have to encounter. And so time goes on, and the child, who should have been weaned at between nine and twelve months, is unweaned at fifteen, indeed, among working women I have known them to be unweaned at two years!

Of course there are babies and babies—it may not be possible to prescribe a rule for all cases; the best age for weaning baby may come just as it is suffering from some infant trouble, in very hot weather, on the eve of a journey,—a dozen things in short may make it advisable to defer the time; but for healthy children, there is no age at which weaning is so easy to mother and child, as from nine to twelve months of age, and the later it is after such age the more difficult.

Yet need it be such a painful time? I think not. I know that in the case of a healthy baby, accustomed to being nursed at regular hours, there actually need be no trial to the child, provided the mother has patience and firmness—not even a tear. Foolishly fond mothers, who have used nature's food as a solace for every woe, will not perhaps find a tearless weaning possible; but I write for those tenderly wise ones who have observed as regular hours for baby's meals as for their own; or, for those about to become mothers. To these last I would say,—as you value your baby's health and comfort, your husband's ease, and your own nerves, *begin with the first day* and accustom the baby to nurse only at certain hours.

Infants have no natural depravity, no inevitable tendency to squall and rage; yet so renowned are they for their exploits in that way, that many men smile cynically—and fathers of families too—at the mention of a "good baby." Nay, mothers of babies who make their life a weariness to them, have been known to smile pityingly at the parents of a happy sleepful child, attributing the restlessness of their own tormentor to its superior organization!

Cleanliness, order, and punctuality are the mother's charms; with these, and plenty of fresh air, most healthy children will sleep twenty out of the twenty-four hours for the first three months of their being.

I would here say, be very careful of waking a sleeping child; one authority says, never do so unless the house is on fire. Accustom it to go to sleep on its bed; lay it down immediately after nursing *from the first*, and you will never find it necessary to rock it to sleep.

A newly born baby will require food oftener than when older; but constitutions differ so much that it is best to consult your doctor as to the number of meals it will require during the day, and then adhere *strictly* to his rules. This point is so often neglected, or, the necessity for some rule for feeding being acknowledged, it is so often considered time enough to begin "when baby gets older," when it is a difficult matter to break habits formed, that for the sake of mother and child, it cannot be too

strongly urged. Physicians say, half the colicky babies are made so during the first month of their life, by the old school of monthly nurses or foolish mothers overfeeding them, or keeping them so warm that every breath of fresh air afterward chills them.

As the child gets older, gradually diminish the number of meals, letting it, however, take as much food as it cares for at each one, until at six months it has but four meals during the day from its mother and one at night. At that age it is well to begin feeding with a little oatmeal porridge, or prepared barley food; begin with a tea-spoonful, gradually increasing the quantity till at nine months or thereabouts it will take a hearty meal of it. Of course every mother must be guided by the constitution of her child in the choice of food; for one child will starve on what another will thrive on; but avoid feeding entirely, or even principally, on corn-starch. The best hour for giving this extra food will also depend on circumstances. A good plan is to nurse the baby at eight A. M. and at noon, at four and at seven P. M.; and at 10 A. M. give the oatmeal or barley gruel. The first step in weaning will be to break off one meal. The four-o'clock meal is the best to wean from first: when the baby comes in from its airing a cup of warm food may be ready for it. It is well, if convenient, for the mother to disappear the first time the substitution is made. Wait a week before weaning from a second meal; then break off the noon nursing in the same way, having the food quite ready when baby comes in hungry. In mild weather, the young child should be out every sunny hour of the day; modern carriages enable it to sleep as restfully as in bed. Let it get quite used to this change before proceeding to another. The weaning from the evening meal it is best to leave till last. When it becomes time for this, give simply as much warm new milk as the child cares to take, then put it to bed as usual. There is now but the night nursing left. This may be broken off by giving a cup of warm milk the moment it wakes, for a few nights, gradually decreasing the quantity till it will no longer wake for it, but sleep till morning, when it is well to give it as much milk as it wants. This may seem a slow and tedious plan in the telling, but it is not so in practice; to a tender-hearted mother, it is at all events preferable to the week of tears and struggles that follows weaning by the short and sharp method.

One word more about feeding the baby. By giving its meals at certain hours and those only, one meal has time to digest before another is taken. You thus avoid a fruitful cause of colic. A baby, too, who is fed regularly only craves food at certain times, and then it will take a hearty satisfying meal, while one nursed every half hour is ever craving and restless; its stomach cannot digest the food so constantly introduced, and crying, wakefulness, and general misery are the result. There will be plenty of elderly women, mothers of large families, to tell you that you can't bring a baby up by book, and that you *must* feed it when it is hungry. And it is hard for a weak young mother, with her one little lamb, to set her

opinion against that of an elderly matron with half a dozen grown children to attest her motherly success. It is hard to do this, even when they tell you, as one such mother told me, that nothing but Winslow's Soothing Syrup saved the lives of all her children! Another point which will have much to do with baby's comfort and your success in effecting the "weaning without tears" is, that it shall not have been rocked to sleep.

I never had any trouble—and never met with any one who had—in making babies go to sleep in bed instead of in the arms, when they have been so laid down from the first. Never accustom a baby to a quiet house or a darkened room when it sleeps: let everything go on just as usual, talking, laughing, music: it will sleep through all. Who has not been met at the door of a room with a finger on the lip, a "Hush! Baby's asleep," and seen the wretched father on tip-toe, afraid almost to rustle his paper? However easy it may be to secure quiet, is it worth while, for a false idea of necessity, to make your husband a martyr, your visitors and friends victims to baby?

So it is with baby putting itself to sleep; it may appear very unnecessary for it to do so to the young mother with plenty of time on her hands, and plenty of love to lavish on the sweet little thing. What so pleasant as to sit and watch it as you rock, slowly drifting into dream-land! To have her baby

in her arms is a delight to a tender mother, and if she were sure of having but the one, perhaps she might safely indulge herself; but most women have household affairs to attend to during the day, and in the evening the child's father—unimportant a member of the family as he may have become since baby's advent—will still be more happy if his wife can spend her evenings with him cozily, as in early married days, than if she is upstairs from seven to nine rocking, walking, singing to the little Molock above. For be sure baby will abuse its privileges, and instead of quietly dropping off to sleep in a few minutes, as it would if put snugly into bed, it will have wide-open sleepless eyes for at least an hour or two; then every time it wakes—and children so used wake pretty often—the same rocking and singing process must ensue, and soon the poor young mother's life is a long weariness. But it is when another little one comes, that the training of the first becomes a matter of importance. Those who do not believe in good babies—that is to say, in healthy, happy ones—goodness in a baby means comfort—will tell you that with all the care and punctuality in the world, babies will be cross: I have not found it so, but I have found that the outrageous, cross, sleepless children, are those who are rocked and carried about, and for whose pacification the whole house caters.

CATHERINE OWEN.

CULTURE AND PROGRESS.

Haeckel's "Evolution of Man."*

THIS work is intended to show that man, like all other organic forms, has come into existence through the operation of natural laws. Its title and its general character recall Darwin's "Descent of Man." But the two works are really as unlike as their authors: the one, a general naturalist, and especially an observer of outward forms and habits; the other, chiefly a zoölogist, who has done most in the direction of embryology. Naturally, therefore, the space which Darwin gives to sexual selection is devoted by Haeckel to an elaborate account of the development from the egg of man and of other forms through which human evolution may be illustrated or explained. The English "founder of modern evolution" is like a judge, calm and impartial. His German disciple is a fiery young advocate, so sure of the justice of his cause that he can hardly see antagonistic facts, or ascribe common sense to his opponents. In his first work Darwin avoided direct reference to the origin of man, while Haeckel, like Huxley, insisted at once upon our

ape-ancestry as one of those "logical conclusions, which are the scare-crows of fools, but the beacons of wise men." For more than twenty years after his return from the "Beagle" voyage the author of "The Origin of Species" patiently accumulated facts and ideas respecting Natural Selection, and the publication of that "epoch-making" volume might have been delayed yet longer but for the author's age and poor health, and the appearance of Wallace's independently formed conclusions. Haeckel, on the contrary—then in his thirtieth year—appeared before the German Association of Naturalists in 1863, as the most decided advocate of the "New Gospel of Science" as put forth by Darwin only four years before. Indeed the contrast in the time occupied by the two minds in reaching maturity of conviction may almost be adduced as an illustration of what Haeckel regards as the fundamental principle of Biogeny, viz.: that a later and derived species manifests within a short period the changes for which a much longer time was required by its predecessors. Nor is this suggestion of an intellectual relationship without foundation. The younger naturalist gives frequent expression to his admiration for the elder, while, in the preface to "The Descent of Man" Darwin says, "If 'The Natural History of Creation' had

* The Evolution of Man: A popular exposition of the principal points of human ontogeny and phylogeny. From the German of Ernst Haeckel. Two vols. 12mo. pp. 971, 15 plates, 330 wood-cuts, and 44 genetic tables. New York: D. Appleton & Co. 1879.

appeared before my essay had been written, I should probably never have completed it."

The keynote of the present work, struck on page six, and reiterated throughout, is in the following propositions:

"The series of forms through which the Individual Organism passes during its progress from the egg-cell to its fully developed state, is a brief, compressed reproduction of the long series of forms through which the ancestors of that organism (or the ancestral forms of its species) have passed from the earliest periods of the so-called organic creation down to the present time. * * * The History of the Germ is an epitome of the History of the Descent. * * * Ontogeny (development of the individual) is a recapitulation of Phylogeny (development of the race). * * * Phylogeny is the mechanical cause of Ontogenesis."

To take an example among familiar forms: the frog of to-day, in its development, successively resembles the gilled salamander; the salamander having gill-slits but no external gills; those wholly fitted for breathing air, but with compressed fish-like tails; and finally those which have cylindrical tails and well-developed legs. According to the principle above stated the ancestors of the frog, which lived in successive geological epochs, more or less closely resembled the forms above enumerated; the two series are parallel, differing mainly in the fact that the individual develops from the egg in a few weeks, while the evolution of the race may have extended over thousands of years.

Where the correspondence of the two series is approximately close, as in the case above cited, the development of the individual is called by Haeckel *Palingenesis*; while *Kenogenesis* designates the result of a modification or abridgment of the process or even the suppression of some of the stages. Our author does not deny that Kenogenesis is by far the more common form of Ontogenesis among the higher animals; but that the imperfection of the embryological record is not conclusive proof of its non-existence is urged upon two grounds of legitimate analogy, *viz*: the development of language, and the imperfection of the geological record. Upon the latter point he indulges in a bit of grim pleasantry as to the "logical" inference that the isolated lower jaws of the earliest fossil mammals would prove these to be the only parts of the skeleton developed.

Darwin traces man's ancestry through the apes, lemurs, etc., to some fishlike animal, and concludes that the early progenitor of all vertebrates "seems to have been more like the larvæ of existing marine ascidians than any other known form." Haeckel constructs (pl. xv) an ancestral tree, and enumerates (vol. II. p. 44) the presumed stages in the direct line from the moner to man. In the following abstract of this list the names of the living forms most closely allied to the several stages are given in parentheses: 1. Moners (Protamœba); 2. Oldest Amœbæ (Automœba); 3. Amœboid societies (Morula larvæ); 4. Ciliated planulæ (Blastula larvæ); 5. Primitive, Intestinal animals (Gastrula larvæ); 6. Primitive worms (Turbellaria); 7. Soft worms (uncertain); 8. Chordonia (Appendicul-

aria and Ascidians); 9. Acrania (Amphioxus); 10. Cyclostomes (Lampreys); 11. Selachian (Sharks); 12. Dipeusta (mudfishes); 13. Gilled Amphibia (Proteus); 14. Tailed Amphibia (Triton); 15. Primitive Amniota (uncertain); 16. Primitive Mammals (Ornithorhynchus); 17. Marsupials (opossums); 18. Lemurs; 19. Tailed narrow-nosed apes (Semnopithecus); 20. Man-like apes (Gorilla, etc.); 21. Speechless ape-like men, or alali (Cretns and microcephali); 22. Papuans, etc.

Great importance is ascribed to the fact that Amphioxus, a vertebrate as to its adult structure, in its mode of development is almost identical with the Ascidians, forms nearly related to, if not members of, the great group of Worms. While, therefore, man is structurally akin to Amphioxus, embryologically, through "that invaluable lowest vertebrate," he is connected with the worm. Our author quotes Goethe in poetic confirmation of our vermian ancestry; but we may suppose that he was either unfamiliar with the Psalmist's humble confession, "I am a worm, and no man," or underestimated the impression it would be apt to produce upon many of his readers. Considerable space is given to an effort to prove that the *archigastrola* of man and many other vertebrates may have been derived from the bell-gastrola of Amphioxus, but so much of technical detail is involved in this subject, and in the account of the formation of organs from the primary germ-layers, that we fear nine out of ten unprofessional readers will omit them, notwithstanding their importance, and that the tenth will wish he had done so.

In addition to the "missing links" acknowledged by our author, there are several other imperfections in his human genealogical tree; and, without going into detail, our impression is that, were all the stages represented by forms differing no more from one another than do stages 13 and 14, their number would be nearer one hundred than twenty-two.

In respect to man, Professor Haeckel is fully justified in calling attention to the temporary gill-arches of the human embryo, and to its possession of a distinct tail at one period; but should he not also note that none of the lower mammals have a *chin*, and tell us whether his *alalus* presented that peculiarly human feature? In this connection it is worth remarking that neither Haeckel nor any other evolutionist believes that the existing anthropoid apes are among the direct ancestors of the human race.

But with all its defects of detail, it is probable that few will undertake to improve upon Haeckel's ancestral tree in the present state of our knowledge; for it must be borne in mind that we have little or no information respecting the early stages of some most interesting forms, as the mud fishes, the gar-pikes, the alligators, the marsupials, the lemurs and anthropoid apes.

The present work displays all of its author's characteristics; his varied information as to facts, and his wonderful apprehension of their significance; his clearness and directness in contrast with the slovenly style too common with German nat-

uralists; his aptness in comparison, as of the embryo chick to an inverted canoe, of an articulated animal to a railway train, and of rudimentary organs to "worthless primeval heirlooms"; the brilliancy and even eloquence of his language, as when he apostrophizes Love as, in its origin, "the elective affinity of two cells," and when he compares the rejection of our ape-ancestry in favor of an Adam degraded by the Fall with the preference of most people for a decayed baron to a peasant as their immediate progenitor. On the other hand, his admission of ignorance upon a few points, and his doubt as to whether the object of the work will be accomplished cannot atone for occasional errors of statement, for the addition of a new set of terms to the already overburdened nomenclature of the brain, and for his overweening positiveness respecting many matters upon which there is fair ground for a difference of opinion; so far, indeed, is this habit carried that he allows himself to speak of some of our purely hypothetical ancestors with as much assurance as if he had dissected them or at least examined their photographs.

We can hardly expect Professor Haeckel to refrain from railing at all ecclesiastical authority, but after the intolerance described by him as shown by Haller toward Wolff, and by Cuvier toward Lamarck and Saint-Hilaire, he would have done well to say less concerning the *odium theologium*, and to display less of the *odium scientificum* in referring to those who have differed with him in opinion, resented his assumption of infallibility, or ventured to doubt or deny the truth of evolution. Most of his opponents are alive and able to protect themselves, and revealed religion has many and able defenders. But all true Americans who love and honor the memory of Agassiz will feel as a personal imputation the words upon page 116 of vol. I.: "Crafty calculation, and well-judged reliance on the want of understanding of his credulous followers can alone have given him courage to pass the juggler's pieces of his anthropomorphic creator as true coin." It is true that Agassiz was sometimes dogmatic,—as are most people of strong convictions, even the author of these volumes,—equally true that he made some mistakes, and that most of his own students are now believers in evolution; but it is false—cruelly false—to suppose him capable of hypocrisy or deceit. Those who watched the last year of his life—literally shortened by devotion to a public interest, the Summer School of Natural History, and who perceived his reliance upon an overruling Providence, whatever their own religious belief, will feel that the most charitable way of accounting for Professor Haeckel's expressions is to suppose him ignorant of what Agassiz did in this country, and incapable of appreciating his motives.

Professor Haeckel frequently refers to the need of investigation of the evolution of functions and habits as well as of organs and forms, and thus suggests an almost unexplored field of research. In this connection he insists that the human mind is likewise the result of natural and mechanical laws

wholly independent of supernatural agency. Indeed, while holding that evolution implies a constant improvement in the moral and intellectual development of the race, he appears to be a confirmed disbeliever in a Creator and a future life. To discuss the ground of his unbelief would lead us too far, but that his doubts respecting the other world have not rendered him insensible to the more tender human experiences is shown by the following paragraph:

"The gradual development of the child's mind is such a wonderful and beautiful phenomenon that every mother and father [note the order of these two words] with eyes to see, takes unwearied delight in observing it. The text books of Psychology alone are ignorant of any such development, and we are almost forced to the conclusion that their authors themselves never had any children."

In short, whatever may be thought of evolution itself, and however little it may please those who have assumed themselves to be "only a little lower than the angels" to be ranked in the zoölogical scale as "only a little higher than the monkeys," few will deny the merits of the present work both as a summary of the main facts in the development of animals, and as a consistent argument based thereon.

Turning to less essential though not unimportant matters, the illustrations are numerous and graphic, although more or less diagrammatic, and the author has too often omitted to name their sources, and state the alterations he has made. The notes which are given together at the end include a useful glossary of terms, references to authors, and occasional qualifications of the text. Upon the whole the translator has done his part well, though we wish his name had been stated, that he had occasionally given the German words in parentheses, and that he had been able and willing to make some additions and corrections, and to render the Index more complete. There are numerous misprints in the volume, and the execution of the woodcuts is not what it should be.

Mrs. Burnett's "Haworth's."*

FEW writers in this country have taken so strong a hold on a good public at a single dash as did Mrs. Burnett in "That Lass o' Lowrie's." The good feeling, the humor, the fine perception of character, and the sincerity of her studies from life, were sure to meet a cordial recognition from a public weary of second-hand pictures, and always glad to receive something genuine. In "Haworth's," Mrs. Burnett works the same Lancashire lead, and with excellent results. There is no character in the book so attractive as Joan, the heroine of her former novel; and, by consequence, what may be called the epic interest of the narrative is not so great. The real

*Haworth's. By Frances Hodgson Burnett, author of "That Lass o' Lowrie's." New York: Charles Scribner's Sons.

center of this story is Murdoch, who is an interesting character, and—barring his occasional over passionateness, which he shares with most of the people in the book—he seems to us a thoroughly real person. But the strongest figure is the burly Jem Haworth, the vulgar, but successful, man, who has worked his way from pauperism to proprietorship, and whose boastful vanity and coarse pleasures all give way before a passionate love of an aristocratic woman. The contrasts of character show us the true artist. How well Haworth shows off against Ffrench, against the proud Miss Ffrench, against Murdoch! What a gap between the vulgar energy of Haworth and the vulgar thriftlessness of Briarley! The latter also contrasts admirably with his wife, and she with Granny Dixon. This eye for color and love of contrast in character is a charming trait; it is the lack of it that makes many of Mrs. Oliphant's books so insipid. As yet Mrs. Burnett is far more successful in sketching low life than that which is higher. This is due in part to her love of what we have called strong color, and in part, no doubt, to the difficulty which every young novelist finds in escaping from the types already set forth by novelists whose works are popular. Janey Briarley is real flesh and blood, a creation that would be impossible to a second-rate writer. There is not a weak point in the drawing of the whole Briarley family. Even the supernumeraries in the story, that cross the stage but once or twice,—Haworth's mother, Floxham, the engineer, the roughs of the "Who'd ha' Thowt it," and the rest of the class,—are all well individualized. But Rachel Ffrench, the lady of the tale, needs exegesis; we never get any clue to her strange character, and she works too much fascination for one whose manners are not winning. Christian Murdoch is almost as elusive as Rachel Ffrench. When we have pointed out this and the excess of emotion, with the lack of periods of repose, we have told its faults. But its excellence is the one supreme excellence of novel writing—it gives us just and charming pictures of interesting human character, and it discloses to us men and women wrought upon naturally by common motives and under new conditions. While the book lacks some of the elements that gave interest to the story of Joan Lowrie's life, it is in some regards decidedly better than its predecessor. Mrs. Burnett grows in the mastery of her material, and we look forward most hopefully to the maturing of her powers with use, and to the steady increase of artistic repose which maturity brings with it. So keen an observer and so racy a writer as she will yet give us strong and well sustained novels of American life.

Bartlett's "From Egypt to Palestine."*

THERE are two methods of making modern books upon the lands of the Bible. One is this: the

author becomes a tourist, and records with more or less enthusiasm his personal adventures in going over the usual and, perhaps, some unusual routes. The other is this: a thoughtful student prepares himself with all diligence for his eastern journey, so that he may know what to see and what to try to see; then he pursues his course, pushing off as widely upon original paths as is possible under his circumstances, and assiduously observing and carefully recording all he finds. Afterward, the notes he has made on the spot are borne into the coolness and rest of his home, where, with the aid of all kinds of literature at his command, they are reduced to a narrative, which is at once a story and a disquisition, worth putting on the shelf for any one's reading and reference.

The book before us is made in this latter way, and so is one of the most valuable and interesting of all the new publications which have come under our examination. Dr. Bartlett has given a graphic account of his travel through Egypt, over the peninsula of Sinai, and across the Holy Land from Beersheba to Beyroot. Everywhere on its pages he shows himself the earnest and discriminating scholar, as well as the devout Christian; and in the quiet of his study he has compared his acquisitions with those recorded by others,—French, English, and American,—and has frankly given his conclusions. It is evident that he has enjoyed the widest range of reading, and knows thoroughly what he is talking about.

Some of the results he reaches are worth noting at the present stage of Oriental exploration. He hardly plants his foot in Egypt before he summarily rejects the showy theories of C. Piazza Smyth concerning the great pyramid of Ghizeh, insisting that all those huge structures near Memphis are tombs, and the celebrated "coffer" is only an empty, and now lidless, sarcophagus. He corrects the loose phraseology of tourists, which pronounces Egypt a "rainless region," by instancing occasions and dates of copious storms. Rameses II. is admitted by him to have been a most powerful and not over-virtuous monarch; but he insists on identifying Menephta, one of his fifty-nine sons, as the Pharaoh of the Exodus and the oppressor of Israel. He disputes Dr. Robinson's site of Etham, and locates that important town not far from the northern end of Lake Timsah. So, farther down in the peninsula, he thinks the mysterious inscriptions of the Wady Mukatteb were cut in the rocks by a mixed multitude of heathen and Christians belonging to a people now extinct, whose very language has disappeared. Of course he surrenders Serbal and Jebel Mousa, and accepts Ras Sufsafeh as the true Sinai. The discussions concerning the entire region of the Exodus and the Wandering are singularly interesting.

Arriving in Palestine, he pursues the ordinary itinerary of travel; but his narrative glances in every direction, in order to touch customs and rites, field and flower, costume and climate. For one thing, he declares unequivocally that, after a diligent inquiry, he could find knowledge of no such thing as a "wine" fermented and unintoxicating;

*"From Egypt to Palestine." By S. C. Bartlett, D. D., LL. D., President of Dartmouth College. New York: Harper & Brothers.

and he asserts that, even during Passover, the Rabbin themselves use ordinary liquor.

In Jerusalem he seems to share the usual comical bewilderment of those who try to trace the course of the ancient walls; and, though he turns abruptly from the traditional church of Jesus's sepulcher, he does not go with Ferguson to Mount Moriah for it, nor, so far as we can find, does he assert that he thinks Calvary was on the knoll close by the Damascus gate. He gets into the Dome of the Rock on payment of two francs, which certainly shows progressiveness on the part of the authorities; but he could not even look into the mosque at Hebron without being stoned, which shows that Mohammedan bigotry has still reserved one spot in which to make a stand. Farther to the north, he takes Tell Hum for Capernaum as against Khan Minyeh, and cannot tell at all whether Kana el Jelil or Keft Kenna is the true Cana of the first miracle.

Mrs. Dorr's "Friar Anselmo and Other Poems."*

MRS. DORR might have won reputation in poetry if she had been the contemporary of Mrs. Sigourney, Mrs. Brooks, Mrs. Osgood, and other ladies who figure in Dr. Griswold's "Female Poets of America." She shows more taste than they exhibited in their productions; is a better and more finished artist, and is not inferior to them in imaginative power. Her choice of words is larger than theirs, leaving little to be desired, except the one quality which is absent from most modern poetry,—originality. She writes carefully, but not individually—not in a way that one instinctively feels is her own. We should not say that she had a more genuine gift of song than some of her sisters, but that she was truer to the gift that she possessed, and less anxious to keep it in perpetual exercise. She does not strike us as seeking subjects upon which to write, but rather as waiting until they seek her, the exceptions being her story poems, if we may call them such, in which she is not at her best. Whether they are versions of old legends, or are creations of her own, we are left to conjecture; but in either event they are not remarkable, nor particularly well told. There is a class of subjects, however, in which Mrs. Dorr appears to advantage, and which she handles skillfully. They come under the head of domestic poems, and concern themselves with events and emotions of daily life,—

"The narrow cares that cluster round the hearth."

They read like records of actual experience, and as such authenticate themselves by the sincerity of their feeling.

Belonging to the same class of personal poems as these are "A Secret," "The Kiss," "This Day," "At the Last," and "Twenty-one"; and related to them, in that they deal with homely, simple,

human themes, are "What She Thought," and "Two," which are perhaps the most dramatic poems in the volume. Mrs. Dorr compares favorably with any of her sister poets as a writer of sonnets. She has something to say in them, and she says it, her conceptions being well thought out, and her expression at once artistic and compact. The most notable of the number (there are some twenty in all) is dedicated to the memory of the young Spanish Queen *Mércèdes*, whose early death was lamented the world over, and nowhere so touchingly as in republican America. We find in these poems, and others that might be mentioned, a sincerity and earnestness of feeling which we are glad to see in this age of artificial writing; we find as much originality of diction as we could expect; and we find in the Ode entitled "Vermont," which was written for the Centennial Celebration of that State (August 15th, 1877), a remarkable justice of thought and largeness of language. It is Mrs. Dorr's most intellectual poem, and the one by which she will be longest remembered.

A New Translation of the *Odyssey*.*

IN their preface to this prose translation of that Homeric poem which best deserves to be known to modern readers, the English scholars who have translated it modestly waive all question of comparative merit in their chosen work. "There would have been less controversy," they say, "about the proper method of Homeric translation, if critics had recognized that of Homer there can be no final translation." Each age must therefore have its own version,—the Elizabethan age, Chapman's "daring and luxurious conceits;" the age of Queen Anne, Pope's "dazzling rhetoric, his antitheses, his command of every conventional artifice;" in the present more romantic age, Mr. Worsley's "masterly translation, which does all that can be done for the *Odyssey* in the romantic style." They do not mention, and perhaps do not know, that Mr. Bryant has made a translation better than Worsley's, and answering to the modern demand for the gravely melodious blank verse, which in some respects is better suited to Homer than the rhyming couplets of Chapman and Pope, or the Spenserian verse of Worsley. If Tennyson, for instance (who could best have done it), had translated the *Odyssey*, he would have used the verse which so fitly falls into cadence in his own "Ulysses." All these good translations, the preface goes on to say, "must always live as English poems,"—which seems to be giving Mr. Worsley more than his due. But, to quote Matthew Arnold, "in a verse translation no original work is any longer recognizable." Therefore these new Oxford translators once more attempt the story in simple prose,—seeking "to transfer not all the truth about the poem, but the historical

* *Friar Anselmo and Other Poems*. By Mrs. Julia C. R. Dorr. New York: Charles Scribner's Sons.

* *The Odyssey of Homer, done into English Prose*, by S. A. Butcher, M. A., and A. Lang, M. A. London and New York: Macmillan & Co.

truth, into English." This is a creditable undertaking, and it has been creditably performed. The version is close, spirited, and shows itself forth as the work of men imbued with the author translated. For the reading of those who wish to know exactly what Homer said, it is, of course, far better than a poetical version.

It has one defect, however, and what is worse, the translators regard this blemish as a beauty. They claim as one of the privileges of a prose version, "that close adherence to the archaisms of the epic, which in verse become mere oddities." And then they proceed, as we must suppose, archaically, but in fact most awkwardly, to call the versatile wanderer Odysseus, "that man of many a shift,"—when as we all know he was often without a change of raiment or even a shirt to his back; they call Calypso "the lady nymph," and speak of "the Ethiopians that are sundered in twain, the uttermost of men." In one place we find this passage: "So these twain stood bandying hard words, but the goodly-greaved Achæans sprang up with a wondrous din, and twofold counsels found favor among them;" in another this: "I had thralls out of number, and all else in plenty, wherewith folk live well." This is not English, archaic or modern,—it is a medley of old and new such as William Morris much affects, and by which he has injured his own style and that of his imitators. Homer was quaint, but it was a quaintness of thought more than of language, and as far removed from pedantry as from other affectations. If an archaic style were to be sought in translating him, it would be rather that of Chaucer than the bastard antiquities which Morris delights in, and of which his translation of Virgil furnishes, perhaps, the most grotesque specimen.

In spite of this blemish, we can seriously commend the book before us. It is much to have the story of Ulysses so clearly told, by men who love the task, and who have profited by the copious erudition of Mr. Gladstone, Matthew Arnold, Professor Newman, and all who in this generation have revived the study of Homer in England. The book is neither large nor costly, and is adorned with two curious illustrations from the antique,—a head of the Cyclops, and an outline of Ulysses and the ram of Polyphemus, passing out together from the monster's cave.

Dickens's "Life of Charles James Mathews."*

A RECAPITULATION of the leading incidents of Charles Mathews's life will show the kaleidoscopic changes which gave it variety. He was born in 1803, the day after Christmas, just as the annual pantomime was produced, and was intended for the church, a calling he abandoned in youth to study architecture under Pugin. It was as a sort of consulting archi-

tect to put into practical shape his patron's suggestions, that he went to Italy in 1823 with Lord and Lady Blessington. He just missed fighting a duel with Count d'Orsay, who seems to have been conceited but good-hearted. In 1827 (after a visit to Wales), he went to Italy again to study, spending much of his time, however, acting at Lord and Lady Normanby's private theatricals at Florence, where he was the architect of the theater and the scene-painter, as well as actor and author. In 1831, having received the appointment of district surveyor, he began professional work in earnest. After four years of this uncongenial work—his office was in Cut-throat Lane!—he gave it up to go on the stage permanently and professionally. He made his first appearance on the public stage in 1835, at the Olympic Theatre, then managed by Madame Vestris. Two years and a half later, he left England for a tour in the United States, bringing with him Madame Vestris, who was six years his senior, and whom he married suddenly before setting out. Returning to England, he managed the Olympic Theatre, and then Covent Garden, and then he went into bankruptcy and was imprisoned for debt. In 1847, he managed the Lyceum, with the same lamentable result,—imprisonment and bankruptcy. In 1858, twenty years after his first visit to this country, he came again and got another wife, who supplied the strength of will hitherto wanting, and resolutely put his affairs in order and kept him out of debt. In 1863 and 1865 he acted in Paris, in French. In 1870, when nearly three-score and ten years old, he started off for a trip around the world, and acted in India, Australia, the Sandwich Islands, and again in the United States, reaching home in 1872. After this little trip, he acted frequently in England, but with somewhat failing force; and in June of last year he died, leaving behind him the reputation of having been by far the best "light comedian" of his generation or ours. He was as light-hearted and as airy off the stage as on, if we may believe his autobiography, not the least curious thing in which is his evident inability to see that his constant financial misfortunes came from causes easily within his own control; he always seems to look on debt as the direct visitation of an otherwise merciful providence.

In this hasty glance over his career no mention has been made of his facility in writing semi-extempore verses of the Theodore Hook kind,—specimens of them are given by Mr. Dickens; or of his extraordinary faculty of "patter" singing; or of his having written the well-known Welsh song, "Jenny Jones"; or of his having more than once exhibited pictures at the Royal Academy; or of his very many successes as a dramatist,—to which we cannot but think the editor has paid scant attention, much less than they deserved. As a writer for the stage he generally relied for his plots, and sometimes for a little more, on some French predecessor; but his dialogue was always noticeably light and lively. And in return for his borrowings from France he enriched it with a play of his own. When he went to Paris in 1863 to act, it was in "L'Anglais timide," an adaptation into French of Mr. Blan-

* The Life of Charles James Mathews, chiefly Autobiographical, with selections from his Correspondence and Speeches. Edited by Charles Dickens. London and New York: Macmillan & Co. New York: Harper & Brothers, Franklin Square Library.

chard Jerrold's "Cool as a Cucumber," made by Mathews himself.

Many of the anecdotes scattered through the biography deserve quotation; and room must be made for one or two. When five years of age, Mathews "ate his terms," "as it is classically denominated," he says,—“that is, learnt my A B C by the ingenious means of gingerbread letters, which I was allowed to devour on correctly naming them, and thus I was tempted literally to 'read, mark, learn, and inwardly digest.'”

Mathews tells a good anecdote of "little Knight," as he was called, an actor at the Theatre Royal, Drury Lane. "He was traveling in Lancashire with four large trunks, with 'E. Knight, T. R. D. L.' on each. He gave sixpence to the guard who unloaded them. The guard surveyed him and his trunks, looked at the direction, and exclaimed: 'T. R. D. L. ! You are no more a T. R. D. L. than I am.'”

As might be imagined, Mathews was not afraid of a practical joke, and he tells of a jest of this sort, less stupid and more amusing than such generally are. He and his fellow-traveler, d'Egville, were living on the shores of Lake Lemman, near the Castle of Chillon :

ONE scorching, hot morning on our first arrival we had taken one of the lumbering boats belonging to the hotel, and, in spite of the baking sun, had rowed ourselves out to the middle of the lake to enjoy a swim. I happened to be undressed first; and, eager for a header, I plunged into the water with the intention of a long dive. But oh! ye gods! I shall never forget it. It was a bath of ice, and I was almost paralyzed with the shock. As quickly as I could manage it, I was out of the refrigerator again.

"How is it?" said D'Egville. "Warm?"
"Delicious!" said I. "Milk, positive milk!" while at the same time I was clambering as fast as I could up the side of the boat.

"What are you coming out for?" said he.
"I want another header," said I. "Let's see who can dive longest."

"Very well; here goes!" and in he went with a joyous shout. In an instant I saw an arm with a clenched fist at the end of it protruding from the surface of the water, and in a second more a face appeared red as a lobster.

"You blackguard!" he gasped; "I'm petrified. It's pure ice. I'll pay you off for this."

"My dear fellow," said I, "you know all our enjoyments were to be in common, and I didn't feel justified in robbing you of your share on this occasion."

An improbable tradition declares that Sheridan once borrowed money from a sheriff's officer who came to arrest him. Mathews records something not more improbable; an entry in one of his diaries under date of Jan. 1843, reads: "Called on L. Levy to pay him £30; borrowed £20 instead."

THE WORLD'S WORK.

Important Advance in Metallurgy.

SOME recent researches into the behavior of metals under the influence of heat, as in annealing, have led to discoveries that may bring about important changes in the present methods of obtaining commercial shapes of metals, wires, rods, bars, etc. The search for a metal that might be used in electric lamps giving light by incandescence led to experiments on platina wire under repeated heating and cooling by electrical currents. A piece of platina wire was brought to a white heat and kept there for some time, when it was cooled and then examined under a powerful microscope. It may here be observed that this heating was practically annealing and the result throws a new light upon this old and important process. To the touch the wire was soft and yielding—practically annealed wire. Under the glass the wire was seen to be full of cracks, chiefly of an arborescent form, branched and running into each other in every direction. The heating results in a kind of rupturing or cracking open; and in seeking an explanation of this it was thought that in bringing the wire suddenly to a white heat, the air held, both physically and mechanically, in the wire was expanded and exploded, tearing its way out and leaving fissures and cracks all over the surface. These fissures are plainly

visible and assume the torn and ragged appearance that might come from such explosions of the contained air. The wire, before stiff, is now soft and yielding, simply because it is cracked, and bends readily at every break on its surface. To illustrate this we have only to paint a sheet of paper with a gum like dextrine or even mucilage. When the paper is stiffened, draw it over a sharp edge and crack the gum and the sheet will bend freely in every direction. Here the cracks are visible and it is easy to see that they allow the gum to bend. It may, from this, be seen that annealing is a rupturing or cracking of a metal, and that its softness and pliability result from the free play given by the cracks. This discovery at once led to a more important step—the repeated annealing of metals in a high vacuum. A strip of platina was placed in a small glass tube by melting the glass over the wire at each end of the tube and thus enclosing a portion while the two ends were left exposed. This wire was then connected with a battery, and when a high vacuum had been obtained by means of a Sprengel pump, the wire was brought to a dull heat by means of the battery. It was allowed to remain heated for a few seconds and then cooled. This heating and cooling was repeated many hundred times in the course of ten minutes. Though the

process through which the wire passed is not visible it can be imagined to be somewhat like this: The sudden heating of the air held in the wire caused it to expand and tear its way out, leaving the wire cracked in every direction. The cooling of the metal produced a contraction tending to close up the ruptured fissures and, as it were, to knead together the particles of the metal. The vacuum assisted the air to escape from the metal by making a difference in the internal and external pressure and undoubtedly hastened the process. At the end of ten minutes the power of the battery was increased slightly and the heated wire showed a pale red. The alternate heating and cooling at this temperature was kept up for ten minutes and then another advance was made in the temperature. In this way the wire was heated and cooled (practically annealed) for five hours till it was raised to a vivid white heat. As the process went on it was found the metal passed beyond its melting point and remained intact in temperatures far above those at which in free air it had melted. On the completion of the process the wire was found to be intensely hard and elastic and of a silvery brightness. Under the glass it showed an absolutely unbroken surface, polished like glass and smoother than any wire obtained by the usual processes. It would seem as if this repeated annealing in vacuum had kneaded and compacted the metal, making it more dense than any known metal, changing its character entirely and materially raising its melting point. It is now as elastic as steel, and, coiled in a spring, retains its elasticity even when at an extreme white heat; furthermore, it can no longer be annealed. The metal appears now to be in a new state of which we had no previous knowledge, and for electric lighting purposes it is practically a new metal with new properties. Experiments with iron and other metals in the same manner produced like results, though, of course, in a varying degree. All the experiments that have led to these valuable discoveries have been performed upon a limited but practically commercial scale because the pieces of wire treated are only required to be very short. For treating iron rods and bars it is proposed to carry on the annealing in wrought-iron tanks from which the air is exhausted by steam power. For small wires and short rods a current from a Faradic machine (this is the new name proposed for dynamo-electric machines) would be sufficient. For larger masses of metals heating in a furnace would be required, the metal being raised to a temperature a little short of melting and then allowed to cool in a vacuum. Even one annealing would tend to compact and harden the metal, but repeated heatings would, undoubtedly, give iron new properties of which we can now have no adequate conception. It may here be observed that annealing in free air tends to soften metals, for the reason that has been given, *i. e.*, cracking; whereas this new method of annealing produces in time an exactly opposite effect. Metals are harder and entirely changed in density and appearance and in their behavior under heat.

Improved Builders' Platform.

A NEW form of suspended platform designed to take the place of staging and scaffolding in erecting chimneys, towers and brick buildings of all shapes, employs screws as a means of support, and is so arranged that the platforms carrying the brick-layers and all their material may be raised with the walls as they are built up. In the case of a square or round chimney of moderate dimensions the foundations are laid and four long iron screws are placed upright on the foundations, a split nut being fastened, or clasped, round the bottom of the screw as a base or means of support. The positions of the screws are decided by the shape of the chimneys, it only being required to distribute them at equal distances and within a few centimeters of the inside or outside of the wall. The brick-work is then built up round the screws leaving each in a well till the wall is raised about 75 cm. ($2\frac{1}{2}$ feet). Another nut is clasped on each screw and rests on the top of the wall. The wall is then raised an equal distance, and when it becomes too high for convenient work the four screws are turned till the tops are level, and then beams are laid on the top of the screws and bolted together, making a square frame. On this frame are laid larger timbers and from these are hung, by means of iron straps, platforms, both outside and inside the chimney, on which the workmen are to stand. Guards are put up round the outside and, if desired, the timber-work overhead may be covered with canvas, making a shelter for the workmen against sun and rain, and enabling the work to proceed in all weathers. From the suspended platforms the men now raise the wall another 75 centimeters and clasp a third nut on each screw at the top of the wall. The screws are then turned simultaneously by the workmen, raising the platform and themselves about 75 cm. The first nuts drop off and are left in the brickwork, and may be pulled out through holes left in the wall for the purpose. The nuts thus recovered are clasped on the screws above and the walls are built up to them as before. It will be seen that by this arrangement each screw always rests on two nuts, the third nut dropping off below and being moved to the top each time the platform is raised. The device has the merit of cheapness, security for the men against the weather and readiness of adjustment to any form of building, as the number of screws may be increased indefinitely and the suspended platforms made to conform to the shape of the structure. When the walls are up, the holes where the nuts were extracted and the wells left by the screws may be filled up by men working on platforms suspended by ropes from the scaffold, and on the completion of the work the whole structure may be taken to pieces and sent down.

Novel Application of the Pendulum to Useful Work.

IN pressing, stamping, and shearing machines the power required to do the work is used at intervals, the time between each period of useful work being employed in feeding a new piece of metal,

or other material to be punched, pressed, stamped or sheared and in adjusting the press or stamp to the next blow. The time required to readjust the machine is always less than the time required to feed it and a loss of time follows in which the machine does no useful work. In power machines this loss is small and not of much consequence. In hand or foot power machines the loss is great, and in a new class of stamping machines this unspent time is used to store up power. To a press of the usual pattern for shearing and punching, is attached a pendulum having a heavy weight, and so arranged that it will swing freely in either direction, or turn a complete revolution on its point of support. By means of a clutch operated automatically, or by hand, the pendulum may be connected with the press at any desired part of its swing. The pendulum is set in motion by means of a hand or foot lever, and made to swing from side to side, or even to make a complete revolution. Just as it begins to fall in each swing it is connected with the press and the fall of the heavy weight does useful work in punching, pressing or shearing. The power needed to start the pendulum is comparatively slight, and, stored up in the pendulum, is spent to advantage, giving better results than can be obtained from any other form of hand-powers. The power spent in operating the machine nearly exhausts the power of the falling pendulum and it almost stops; but if properly adjusted to the work, there is enough momentum left to make it pass the center, and a slight push with the hand or foot sends it into a position for the next blow. The time spent in swinging the pendulum back to an effective position is also spent by the operator in feeding the machine. It is reported that presses of this pattern enable one man to develop an amount of power equal to the power of two men working at the levers of an ordinary press. The machines are made in a variety of forms for different classes of work, and the weights on the pendulum are made in sections so that the power of the press may be changed at will. The

lengths of the pendulum may also be varied to increase the power at a slight decrease in the speed of the machine.

Memoranda.

IN compounding engines the latest device is to make the smaller, or expansion, cylinder serve as a slide valve for the larger cylinder, the piston being very thick and opening and closing the ports while traversing its own cylinder. Extra slides and ports are introduced for reversing. The design is ingenious and is said to work with economy.

* The ordinary farm harrow is an inconvenient machine to transport, and various attempts have been made to fold it or make it of flexible chains to reduce its shape when being moved from field to field. The latest notion in this direction is to make two sides in the form of sled runners and to split it in two in the middle, and to secure the two parts together by an iron brace pivoted at the ends and latched. In use, it lies flat on the ground, in transporting it the two halves ride on edge with the points turned in, the same latch serving to keep it rigid in either position.

Dephosphorizing, or extracting the phosphorus from iron, still attracts very great attention among metal works, as was observed in the last two numbers. A later experiment on pig iron that gave, on analysis, 1.44 per cent. of phosphorus was blown in a Bessemer converter, and just before the end of the blow 3 per cent. of the weight of the iron of pulverized hammer scale was introduced through the blast pipe, or blown into the converter in the form of dust. The resulting steel was drawn into a bar that appeared to have the properties of malleable iron, standing as high a heat in the forge as the best iron and welding readily. The steel was made without the aid of lime, magnesia, spiegel or ferromanganese, and on analysis showed only .015 per cent. of phosphorus. The experiment is regarded as promising important results.

BRIC-À-BRAC.

Love-Song.

(AFTER THE ANTIQUE.)

CALL the facets of the dew!
 Bid them sparkle for thine eyes!
 Rob the violet's tender blue,
 Borrowed from less azure skies!
 And charm the Rose, that softly glows,
 To lend thy cheek its changing dyes!

But deem not, Maid, an honest mind
 Such fickle toys as these may win;
 The painted rind may charm and blind,
 Yet dare not show the cheat within.
 Dear Maid, a sweet, shy Rose thou art
 Ah—tell me! hath the Rose a heart?
 W. M. BRIGGS.

Rev. Biddlecomb Ingersoll Vindicates himself.

[The following letter is received too late for insertion in our department of "Communications," and our regard for a very worthy, and, we are sure, an entirely innocent man, leads us to insert it here rather than defer it for another month.—ED.]

EDITOR SCRIBNER'S MAGAZINE:

DEAR SIR: Though subjected to an examination by my church and fully acquitted of all that was charged against me, there are still thousands of the outside public who have not heard my defense. I write this explanation, therefore, that I may prevent the evil which would arise from the example of the apparent falling from grace of an upright man and particularly of a minister of the Gospel.

That I may not afterward be obliged to refer to them I will now mention a few circumstances and particulars relating to myself that are necessary to a full understanding of my story.

Several years after I had been graduated from the theological seminary I received a call from the Presbyterian Church in the little village in which I have preached for the last five years. My congregation was small, but I was not dissatisfied as most others would have been, for I recognized the great fact that energy and talent, like steam, though infinitely circumscribed, will make themselves felt sooner or later. I have always been an advocate of the most rigid and uncompromising orthodoxy, glorifying in the very difficulty with which the incidents of the Mosaic history are comprehended as literal facts. I found time, while not neglecting my clerical duties, to denounce the weak and harmful fallacies of modern science in a series of articles in our weekly paper. I will say nothing further about these articles except that they have doubtless produced in some measure the effect for which they were written.

And now, leaving these preliminaries, I come at once to the matter in hand. It was in the fall of 1878 that business connected with my church called me to that town in which I became a victim to such a chain of unfortunate and incomprehensible circumstances. The distance between the two places, as every one knows, is from eighty to ninety miles. Arriving at my destination about noon I took up my abode at the hotel which had been recommended to me. On registering my name I was quite agreeably surprised by the cordial and gracious manner of the hotel clerk, for I had always been led to believe him a very offensive and impertinent individual. After obtaining some refreshment, of which I stood in considerable need, I intended to proceed at once to the business for which I came, but was informed that Mr. Timothy Wheeler, the secretary of the literary association, awaited me below. If there is in all the world an excusable feeling of egotism and self-esteem, it is that thrill of pleasure that fills our hearts when we find that our writings, unknown to ourselves, have stolen forth from the narrow limits in which they first saw the light, and that we are known outside of our apparently circumscribed field of action.

Mr. Wheeler seemed very much pleased in making my acquaintance, and said that, hearing of my arrival, he had at once come over to pay his respects and to see that I was in every way comfortable. He expressed his satisfaction on learning that I was, and then there ensued a very interesting conversation in which he assured me that he was entirely of my belief and manner of thinking. He said several things of which I could not exactly catch the meaning,—one of which was something about a certain rib story which by some mistake he persisted in attributing to me. But upon the whole I thought him very polite and entertaining.

I was absent from the hotel attending to the affairs of which I have spoken until about five o'clock in the afternoon, and on my return found

that several clergymen of different denominations had called on me in my absence. It would be an untruth to say that I was not pleased, nay, flattered at this intelligence. A Presbyterian divine had left a package of tracts, doubtless for my approval and criticism. I was now pondering upon the advisability of returning his call in the evening, when the card of Dr. Jonah Bloodgood was brought to my room with word that the gentleman was waiting for me in the hotel parlor. Realizing now more than ever before the constant demands and cares to which a career like mine is subjected, I descended to meet him. He was a short, stout old gentleman who looked at me through his spectacles with an air of great veneration and complacency; but I did not perceive this until afterward, as on entering the parlor I was surprised at the presence of a young and beautiful girl who was introduced to me by the doctor as his niece, Miss Eugenia Dyer. He said that she was visiting with his family at the hotel and having expressed a wish to make my acquaintance he had taken the liberty of sending up his card, and now that he had explained himself he would leave us and go about his business. My habits of reading and meditation had unfitted me to a certain extent for the society of the fairer sex, and I must own that the seclusion of my study had never before seemed so safe and pleasant. However, after a short conversation about the weather and the healths of the different members of her family, at the close of which she requested me to inscribe my name in her autograph album, I had recovered my natural equipoise. She was all that was interesting and gentle; and yet there was in her composition an undefined incoherence, an inclination bordering upon levity, which, seek to banish it as I would, still intruded itself upon my thoughts. I was discomposed, to say the least, when she asked me a certain profane question about Adam and Eve. And when finally she made a very pointed remark about the temperature of the infernal regions in its relation to myself, I was completely unnerved and withdrew from her presence with as much haste as gentlemanly demeanor would permit.

Shortly after supper I was informed that the carriage was waiting. This surprised me not a little, for though I had given notice of my intention of calling on the Presbyterian divine, I had not ordered a carriage, and at first decided not to avail myself of the kindness. But on second thought, as my host had been so attentive and so thoughtful of my welfare during the short stay which I had made with him, I concluded to accept of his civility. But first, as I intended to take the night train for home and could not pay for my lodgings after making my call, I determined to do so before I went; but here another agreeable surprise awaited me, for I was informed that Mr. Wheeler, on behalf of the association, had already paid my bill. I have never had any scruples in accepting the hospitalities which are generally offered to clergymen by the world. I therefore made no objection, and now, preparing myself with the package

of tracts, I left the hotel. I was undecided in my choice of two carriages drawn up before the entrance, until the driver of the one nearer me got down and opened the door. "All right, I know the place," said he, as I attempted to explain where I wanted to go. Then, banging the door after me, he sprang upon the box and the carriage rolled away over the pavement. The rapid motion of the vehicle communicated itself to my thoughts. I felt an increased confidence in my powers of logic and persuasion, and visions of oratorical success, wider fields of usefulness and largely increased emoluments mingled with dreams of a softer nature, the subject of which, as being irrelevant to my story, I will not dilate upon. Suddenly we came to a standstill, and stepping from the carriage, I precipitated myself against Mr. Wheeler, who was, singularly enough, waiting for me on the sidewalk, and who said, pleasantly, "You are just on time;" then, turning to a gentleman who stood beside him, "This is Mr. Bird, who will have the pleasure of introducing you." I wondered that such a formality should be necessary, but had passed that point where I could be very much astonished, and in fact I was so completely dazed from that time forward that I have but an indistinct recollection of all that happened. While we were engaged in conversation the carriage was driven away, but I was too much preoccupied to attach any importance to this incident, though I recalled the fact to mind later in the evening.

I followed my companions up a long stairway, then through a hall which opened into a small ante-room, where we found another gentleman who, being introduced to me as Mr. Miller, remarked that it was the finest house he had ever seen. I did not exactly agree with him in this opinion, as the walls were very dingy and there was an unfinished look about the apartments quite at variance with my ideas of what it should be. I acquiesced, however, and he then proceeded to hand me an envelope, saying that this was the way they did things there. I had an indistinct feeling that they had a very queer way of doing things, but as I knew little of city ways and as Mr. Bird asked me if I was ready, I thrust the envelope, which was rather thick and heavy, into my pocket and followed him through a little door which opened about opposite to the one we had entered. At once I was almost blinded by a brilliant light, and at the same time deafened by a terrible noise which I can liken to nothing but the loudest thunder. Then, as I gradually recovered my sight and hearing, I became aware of a thousand upturned faces and the clapping of hands and stamping of feet. Like lightning, the vision of a vast practical joke flashed through my brain. It was too much! I remained, for one moment, the objective point of two thousand piercing eyes, and then found myself rushing like a madman down the stairway by which I had entered. My carriage was before the door. I knew it by the gray horses and the small negro coachman. I ordered him to drive me to the depot, and upsetting a short, stout old gentleman who stood in my way, jumped in and slammed the

door. The carriage rattled away down the street; the strange events which had happened seemed like some wonderful and disagreeable dream. But coming more to myself, I became aware of a delicate and peculiar perfume which pervaded the vehicle, reminding me of my interview with the fair Miss Eugenia. A curious sensation arose within me,—a sort of an intuitive consciousness,—developing from a presentment into a conviction. The sweat stood out upon my forehead as there burst forth in close proximity to my ear an appalling scream, followed in rapid succession by several others of equal intensity and shrillness. The driver stopped; we were immediately surrounded by an excited crowd, and I was dragged forth and suffered great damage both in my person and my habiliments, until I was taken from the clutches of the mob by the officers of the law.

Conscious of the rectitude of my character, I bore without a murmur the treatment which is accorded by the law to the commonest criminals. I could afford to laugh when I was accused of personating the lecturer and absconding with the three hundred dollar lecture fee. In fact, the lecturer himself, though indulging in much levity at my expense, was the first to pronounce me innocent in the matter. The charge of attempted abduction was so ludicrous and so at variance with every principle of my life, that I could regard it with indifference.

But there is a thought which continually fills me with the deepest annoyance and chagrin. It is that I—a champion of the truth—should have been mistaken so easily and by so many people, through the similarity of my name, for a man whom I have learned to regard as the very representative of evil.

B. INGERSOLL.

NO. WARE, MASS., October 4, 1879.

The Lory-Lye.

[One of our readers sends us the following translation of Heine's famous poem. It was printed alongside of the original text in a piece of sheet music by a German composer.]

I KNOW not what may be the reason

That I am full of dole.

A tale of long by-gone season

Fills all my heart and my soul.

The air is cool and nighted,

And silent flows the Rhine;

The top of the hill is brighted

With setting sunny shine.

The fairest maid is sitting

On yonder point of rocks,

Her golden jewels are flitting,

She combs her gold-colored locks—

She combs them; her comb is gold-wiry;

She sings a song of love;

It has a bewitching, fiery

And mightily charming tune.

An ardent wofulness seizes

The ferry-boy in his skiff,

He looks above and he freezes,

He sees not the threatening cliff.

Ah! round him the waters are canting.

The skiff, the boy sinks hard by;

This has, with her lays enchanting,

All done the Lory-Lye.

A Microscopic Serenade.



O COME, my love, and seek with me
A realm by grosser eye unseen,
Where fairy forms will welcome thee,
And dainty creatures hail thee queen.
In silent pools the tube I'll ply,
Where green conferva-threads lie curled,
And proudly bring to thy bright eye
The trophies of the protist world.

We'll rouse the stentor from his lair,
And gaze into the cyclops' eye;
In chara and nitella hair
The protoplasmic stream descrie,
Forever weaving to and fro
With faint molecular melody;
And curious rotifers I'll show,
And graceful vorticellidæ.

Where melicertæ ply their craft
We'll watch the playful water-bear,
And no envenomed hydra's shaft
Shall mar our peaceful pleasure there;
But while we whisper love's sweet tale
We'll trace, with sympathetic art,
Within the embryonic snail
The growing rudimental heart.

Where rolls the volvox sphere of green,
And plastids move in Brownian dance,—
If, wandering 'mid that gentle scene,
Two fond amœbæ shall perchance
Be changed to one beneath our sight
By process of biocrasis,
We'll recognize, with rare delight,
A type of our prospective bliss.

O dearer thou by far to me
In thy sweet maidenly estate
Than any seventy-fifth could be,
Of aperture however great!
Come, go with me, and we will stray
Through realm by grosser eye unseen,
Where protophytes shall homage pay,
And protozoa hail thee queen.

JACOB F. HENRICI.

The Wail of the "Personally Conducted."

CHORUS HEARD ON THE DECK OF THE LAST RHINE
STEAMBOAT OF THE SUMMER OF 1879.

INTEGRAL were we, in our old existence;
Separate beings, individually:
Now are our entities blended, fused and
foundered—

We are one person.

We are not mortals, we are not celestials,
We are not birds, the upper ether cleaving,
We are a retrogression toward the monad:
We are Cook's Tourists.

All ways we follow him who holds the
guide-book;
All things we look at, with bedazzled optics;
Sad are our hearts, because the vulgar rabble
Call us the Cookies.

Happy the man who, by his cheerful fireside,
Says to the partner of his joys and sorrows:
"Anna Maria, let us go to-morrow
Out for an airing."

Him to Manhattan, or the Beach of Brighton
Gaily he hieth, or if, fate-accursèd,
Lives he in Boston, still he may betake him
Daown to Nantasket.

Happy the mortal free and independent,
Master of the mainspring of his own volition!
Look on us with the eye of sweet compassion:
We are Cook's Tourists.

H. C. BUNNER.

Ballad of Blue China.

THERE'S a joy without canker or cark,
There's a pleasure eternally new,—
'T is to gaze on the glaze and the mark
Of china that's old, and that's blue:
Who'd have thought they would come to us,
who
That o'er loot of an empire would hang
A veil of Morrisian hue,
In the reign of the Emperor Hwang?

These dragons,—their tails you remark,
Into bunches of lotus-flower grew,—
When Noah came out of the Ark,
Did *these* lie in wait for his crew?
They snorted, they snapped, and they slew,
They were mighty of fin and offang,
And their portraits Celestials drew,
In the reign of the Emperor Hwang.

Here's a pot with a house in a park,
In a park where the peach-blossoms blew,
Where the lovers eloped in the dark,
Lived, died, and were turned into two
Bright birds that eternally flew
Through the boughs of the May, as they sang;
'Tis a tale was undoubtedly true
In the reign of the Emperor Hwang.

ENVOY.

Come, snarl at my ecstasies, do,
Kind critic, your tongue has a tang,
But a sage never heeded a shrew
In the reign of the Emperor Hwang.

ANDREW LANG.

SCRIBNER'S MONTHLY.

VOL. XIX.

DECEMBER, 1879.

No. 2.

THE CAPITOL OF NEW YORK.



THE "NORTH CENTER." [THE OLD PORTION (THE FIRST AND SECOND STORIES) IS NOT HERE SHOWN.]

At the beginning of the year 1875 the new Capitol of New York at Albany presented a disheartening aspect. It had then been in progress for seven years, had reached the middle of the third story and had cost over five millions. It consisted outwardly of a vast paralleloiped of whitish gray granite, 300 by 400 feet in area, hollowed out at a distance of 100 feet from the outer face into an interior court. This ground plan was broken by trifling projec-

tions which divided each front into five parts, a projecting center flanked with recessed wings and these again with projecting pavilions at the corners. A model of the building showed that in front of each of the central divisions it was proposed to build a three-story portico, and that from one end of the interior court a tower was to rise to the height of 350 feet or thereabouts. The diagram (page 162) gives an idea of the architectural treatment of the building for the

two principal stories. It is very much the same sort of thing, it will be observed, as the New York Post-Office, but upon the whole considerably worse. It is true that the basement of the New York Post-Office is of a light and airy character, and that the basement of the Albany building gives some sense of weight along with its uncouthness, but that advantage is fully neutralized by the fact that the architect of the Post-Office had perhaps too much perception, perhaps too little money, to decorate the curtain walls as well as the projections with pilasters between the openings, and therefore kept, what was nowhere to be found in the Albany building, some spaces of respectable and untreated wall. The openings in the Post-Office, too, give much more impression of depth than was to be had from the Capitol. In neither building was there evidence of any intention to design a whole with necessary and interdependent parts; to signalize in treatment portions superior in importance and portions subordinate to them; to adapt structure to function in expression as well as in fact. Apart from this consideration, which seems radical, the projections in both

cases sufficed to destroy the effect of a great stretch of level wall pierced with the receding ranges of equal openings, while yet they failed to substitute for this the interruption of powerful masses. In neither

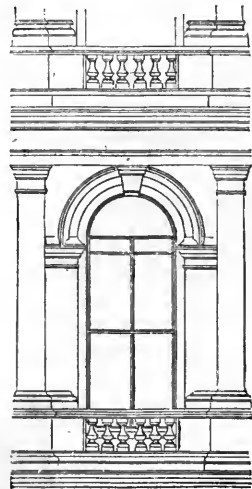

OUTSIDE VIEW OF WINDOW, OLD PLAN.

did the detail, perfectly uninteresting in itself, gain anything from the manner of its disposition. Still, had the original design for the Capitol been executed, the result would have been a building far more huddled and confused than Mr. Mullett's masterpiece, and much of this huddle and confusion would have been added to it by the wonderful wilderness of things into which it was meant to break out at the top: a row of round dormers in metal, eight little copper-covered towers in Sir Christopher Wren's manner, Greek pediments, Louis Quatorze pavilions hung with cast-iron festoons and crowned with iron balustrades, and crestings wherever crestings would go.

It is not fruitful perhaps to find differences between the architecture of the Post-Office and the architecture of the Albany Capitol, as the Albany Capitol was meant to be, and certainly it is not desirable to beat the bones of the buried; but it is necessary to account for the allowances which will always have to be made for the completed building, and to indicate why what has been done since the State discarded the first design has failed to redeem it entirely. The interior of the building showed in 1875, and still shows, that the exterior architecture, such as it has been described, was the main thing in the designer's mind, and that not until after his vision of it was embodied on paper, did he begin to consider how the



INSIDE VIEW OF WINDOW, ASSEMBLY CHAMBER.

interior was to be made to conform to it. His belated efforts were not very successful, for the two legislative chambers were placed sixty feet from the ground; corridors 340 feet long were left without light, except from a window at each end; staircases were lighted only from the top, and so forth. With all this there was such a waste of room that the ground plan is dotted over with stray spaces described as "air" and "light," and one great cavern on the entrance floor, lighted only on one side, is labeled an "art gallery." Some of the details of the interior work were executed, and remain to testify the character the completed work would have had,—among them an entrance hall furnished with clumsy piers and ceiled with flat brick arches, and another filled with polished granite shafts with polished bases and marble capitals, which are subjects rather for wonder than for criticism. Some of the interior architecture, which was rescued from execution, had been carried far enough in design to show what it was meant to be. The Assembly chamber, the most important room in the building, was to be a parallelogram of 140 feet by 85, dimensions surely ample for architectural effect; these were to be neutralized by devices which would have been ingenious, had they been means to an intelligible end. The axis of the room was made its breadth and not its length; the lower windows were cut off on one side by a corridor, and obstructed on the other by a portico; the entrance was effected by a rise of five spiral steps in each of four corners from the floor of the corridor; the ceiling was to be a flat covering of cast-iron, and cast-iron columns supporting a plastered screen of brick were to form the fronts of the galleries. The detail which was to enhance the effect of these dispositions was to be of the same character as that which may still be seen in the entrance halls,—detail equally without invention and without knowledge, the rudeness of which had no hint of vigor nor its feebleness any chance of being mistaken for refinement.

What is most singular about the building thus designed and thus in great part determined is that up to 1875 it does not seem to have occurred to anybody—certainly not to anybody in authority—that the impending edifice would be other than admirable. The commissioners of the new Capitol (up to that time a specially appointed body) were probably not appointed for any knowledge of architecture which they either professed

or were presumed to possess, though several of them were men of much experience in the management of public works, and all of them were respectable and eminent citizens. They had taken the customary pains to secure good results. They had invited architects in general to submit designs, and architects, to the number of three, had taken chances in a lottery for the control of a work which any architect in the country



DORMER, STREET SIDE.

would have been glad to undertake. They had chosen what it is just possible was the best of the designs thus obtained, although, in that case, it cannot have mattered much which one they did choose. The design thus selected had been "endorsed by leading citizens," and among them some leading citizens who did pretend to knowledge of what constitutes merit in an architectural

design. The tone of the discussions about it in the Legislature was the same as that taken by Governor Robinson's last message concerning the completed fragment. It was magnificent, but expensive. It is even alleged that the American Institute of Architects solicited the designers to send their model to the Vienna Exhibition as a specimen of what American architects could do; but that piece of justice was spared us.

In 1875 grumblings began to be heard, not about the merit of the design, for that had not been publicly called in question, but about the cost of the building, the practical inconveniences it threatened, and the delay in its construction. The work was so far advanced that legislators and state officers could see for themselves that the cost

were drawn, was that which he gave them. The result was a feeling, apparently quite natural, though nobody had given way to it before, that there must be a more excellent way to complete the building than that set forth by the plans, and a more suitable person to direct its completion than the author of those plans. These reflections bore fruit, early in the summer of 1875, in the appointment of a board of professional advisers, composed of Messrs. Fred. Law Olmsted, Leopold Eidlitz, and Henry H. Richardson. Mr. Olmsted is not an architect, and his specific services to the new Capitol will be mainly brought into requisition after its architecture is done; but his great experience in the administration of public works, in the creation of the Central

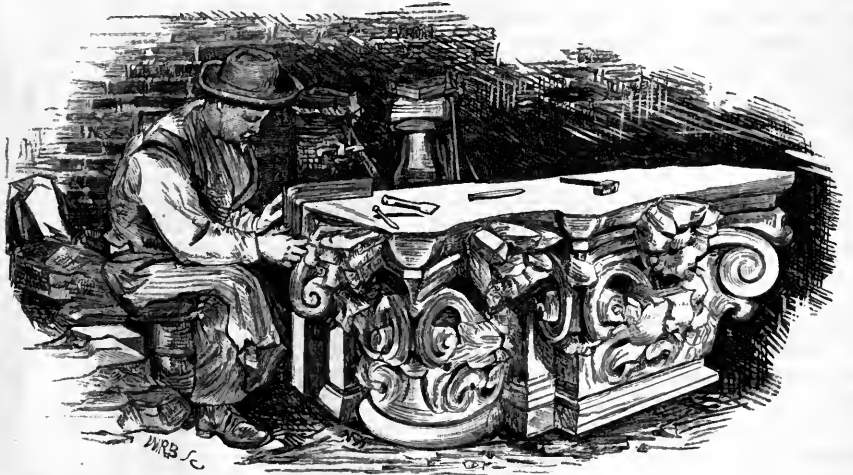

A CAPITAL FOR A STREET DORMER WINDOW.

was likely to be enormous, and the arrangements for the transaction of the public business far from admirable. During the session of that year the commission was changed to an *ex-officio* body, composed of the lieutenant-governor, the attorney-general, and the auditor of the canal department. Mr. Dorsheimer, the lieutenant-governor, became the chairman of the commission, and to this fact the State directly owes whatever has been done for the redemption of the Capitol. But for the perfectly fortuitous circumstance that the duty which thus fell to him was a duty for which he had a special fitness, there would have been nothing in the building worth describing or illustrating. The first real examination which had been given the plans during all the years which had elapsed since they

Park particularly, and the brilliant results of that administration, made him a most valuable member of a body which was to undertake the reclamation of a less tractable wilderness than that out of which the Central Park was made to blossom. Mr. Eidlitz had shown in such works as the Academy of Music in Brooklyn, and the Produce Exchange and the Continental Bank in New York (though always under such limitations, of one sort or another, as had forbidden him to exhibit it fully) a pre-eminent capacity for monumental design. Mr. Richardson had not at that time completed Trinity Church in Boston, by which he has since become so well known, but in less important buildings he had exhibited the qualities which distinguish that work—the same romantic impulse, the same large

picturesqueness, and, what is perhaps best, and certainly rarest of all, the same sense of the all-importance of the value and relation of masses, and the same power of disposing them.

To the board thus constituted the commission addressed a series of questions, almost all of them of a practical kind. They were instructed to examine the work done and the plans for the work not done; to consider whether the building could not be reduced in height, since it was committed in every other dimension; whether the legislative halls were too large, and if so, how they could be reduced; to examine the dimensions and arrangement of other specified rooms, "and, lastly, all questions of taste and judgment, which may suggest themselves as of practical importance to be now discussed." To these questions the report of the board, presented and printed early in 1876, was one form of the answer, and the designs submitted with it were another. The report was an elaborate and interesting discussion of the building as it stood, and of the plans for completing it, from the points of view of convenience, of economy and of art. Neither the defects nor the causes of them were far to seek, but even a partial cure was hard to find. As the doctors say, diagnosis is more advanced than therapeutics. The conversion of the Capitol into a really convenient, a reasonably expensive and an altogether dignified public building, was, as the report pretty plainly intimated, out of the question, except by a recourse to the heroic remedy of dynamite. The position and the dimensions of every important room had been fixed, and though it was feasible to effect some improvements in arrangement, the essential faults of the plan were fastened permanently upon the building. Outwardly, above the basement, the building was girdled by two tiers of the windows, a specimen of which has been given (page 162), 130 of them in all. It was indeed possible not to build any of the things designed to be put above this line, and this was a valuable privilege of which the architects fully availed themselves. But to impart any expression of breadth and serenity, of strength and richness, to the building as a whole by the treatment of what remained to be done, was as hard and ungrateful a problem as often comes to a designer. The report of the advisory board summed up the architectural faults of the building, by saying that it lacked repose and dignity.

The first purpose of the preliminary studies for the completion of the building was to amend this fault. These studies, it is understood, were prepared by Mr. Eidlitz. One can readily understand how a very brief season of experiment should have convinced a designer that any real expression of dignity, considering the unalterable divisions of the building, required the suppression of the subdivisions marked by the

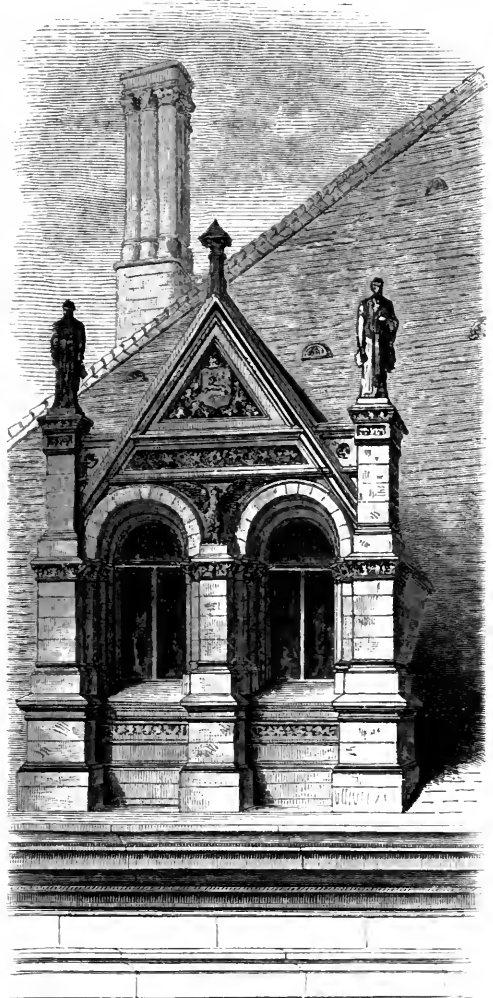

DORMER, COURT SIDE.

pillasters and the substitution, in the principal masses which contained the great rooms, of an unbroken field which could be emphasized as one feature of the building, and not broken into a succession of features insusceptible of emphasis. When this was done, when the pillasters had been suppressed and

the division they marked had been disregarded, the "change of style" had been virtually effected. The effect of this change of style upon the architectural profession was extraordinary. No complaint of the original design had ever been heard from the profession, no hint that the building would be inconvenient or that the architecture of it was puerile. But chapter after chapter of the Institute of Architects, within

leads a man to regard as sacred those processes of work to which he is accustomed, and which in this case were described as "the received rules of art" and the "accumulated experience of centuries." To an architect of this kind, knowledge of styles is the sum of professional knowledge, and the grammatical putting together of forms of the same period and school is the highest professional achievement. To such an archi-

tect the mixture of styles is naturally not only the chief, but the only architectural sin. But then there were also among the remonstrants men who might have been expected to admit that at most fidelity to style is but a means to the end of artistic quality, that there are other qualities besides that of purity, which only fidelity to style is calculated to attain, and that the Albany Capitol, as at first designed, was very far from being a pure building, and that it was impossible to make it pure. If it could not be made pure, it seems praiseworthy to attempt making it at least peaceable. With such men as those of whom we are now speaking, one noble window, or one exquisite capital, might have been expected to outweigh all the bewildered frippery of the old design. A professional journal which was one of the most influential and most temperate of the professional opponents of

the modified design has indeed said, since the completion of the existing fragment of the Capitol, that there can be no serious question that the building gained very greatly by the change of architects, which is perhaps as near as could be hoped for to an explicit admission that the opposition was mistaken; but there has been no such admission, express or implied, on the part of the professional bodies which warned the state not to expose itself to the obloquy of posterity. If the opposition was mistaken, it seems to follow that in so far as it was successful, it has injured the building. It was so far successful that after the arcade (which, next to the roof, forms



THE GOLDEN CORRIDOR.

and without the state of New York, solemnly rose up and protested against a design which involved a change of style, and assured the state that dreadful consequences to art would ensue from a public building erected in two styles. Nothing like this had been seen since the horror of British architects over the project of that "vandal," Mr. Burges, for decorating the interior of St. Paul's. No doubt there was a good deal of trades-unionism in the attitude of the architects, since the original architect of the Capitol was also the president of a "chapter;" and a good deal more of what we may call unconscious trades-unionism,—meaning the habit of mind which

the most conspicuous and effective feature of the existing "North Center," in which the Assembly chamber is placed) had been built up to the springing line, and the treatment of the deep single arches, which flank it had been determined, the legislature enacted that the outside of the building should be completed in the Italian Renaissance style in which it had been begun,—a method of settling the dispute which would have been even more satisfactory if every legislator who voted for it had been required to record, with his vote, his own definition of Renaissance. A literal compliance with this statute was, of course, impossible without destroying the Romanesque work which was already in place. Mr. Richardson, upon whom the commissioners devolved the execution of it, set himself to comply with the spirit of it; and, as the restoration of the formal Renaissance of the lower stories was æsthetically out of the question, completed the exterior in free Renaissance. There was, indeed, but one architectural period in which precedents could be found applicable to the solution of his problem, and that was the great period which produced the chateau architecture of Francis I.,—the fantastic front of Blois and the aspiring masses of Chambord. The chateau was the monumental expression of the imposition of antique culture upon a world yet mediæval. Technically, the task of the French court architects of the sixteenth century was very much the same as the mission which so many of the younger generation of English and American architects have assumed, to combine free planning and free design with antique detail,—in short, to do "free classic." It would be hard measure, however, to our own time, to compare the "Queen Anne" work, which these "pale children of the latter light" have for some years been doing, with the romantic richness of the French sixteenth century work, before that in it which was native and vital had been overborne by that which was exotic, factitious, and formal merely. That which was essential in it was the massing and the outline, which give its character of romantic richness; that which was exotic was the classic detail which alone is common to it with Queen Anne, and which, in place of romantic richness, gives, as the highest success of the original or the revived Queen Anne,

a comfortable *bourgeoisie*. The French architecture of the sixteenth century had the further advantage, from what we have called the trades-union point of view, that it was a mixture of styles which, by lapse of time, had come to be recognized as itself a style. One is compelled by the evidence to confess that there are minds so constituted or so trained, as to be somehow soothed, in the presence of a contemporary heresy, by the reflection that the axial lines of openings are disregarded in the town-hall of Beaugency, and that Gothic niches are flanked by classic pilasters in the façade of the town-hall of Orleans.

The successes of Mr. Richardson's work are where we should expect to find them, both from the character of Mr. Richardson's own gifts and from the limitations under which he has worked. In general composition, the existing fragment of the new Capitol is surprisingly successful. From any point of view from which the outline of the masses can alone be seen, from the river bank below or from the river bank opposite, it already crowns with a picturesque stateliness the hill on which it stands; and both its picturesqueness and its stateliness will be immeasurably enhanced when this fragment comes to take its place in the completed pile, encompassed with an ordered group of steep-roofed masses, and crowned with the looming bulk of the domed tower. Even the fragment recalls Scott's "impression" of his own romantic town. Its

"ridgy back heaves to the sky,
Piled deep and massy, close and high."



CAPS TO COLUMNS UNDER REPORTERS' GALLERY.

Nearer at hand, too, from any point of view from which it is possible to forget the monotonous huddle of the lower stories, the aspect of the work is impressive. The projections which form the small flanking towers are still

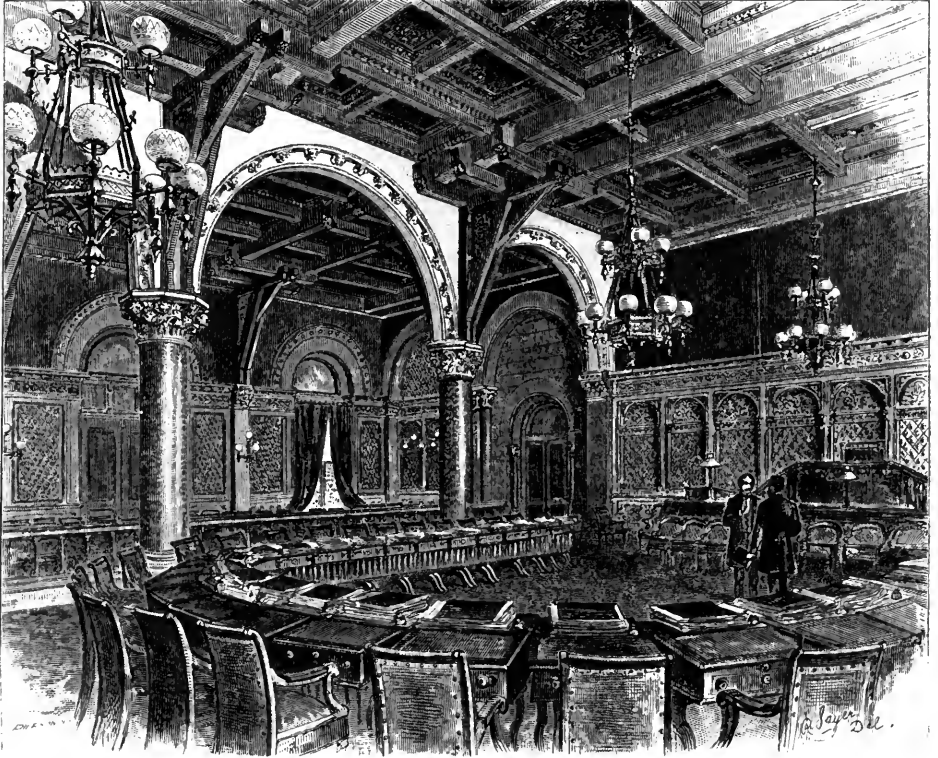

THE COURT OF APPEALS ROOM.

insufficient; but in the upper stages their dimensions are made the very utmost of. Hard as it is, in this whitish-gray material, to get a decisive shadow, there is a real depth in the upper arcade, and still more in the tower arches which flank it, as there is a real breadth in the belt of plain wall above the arcade, and in the surfaces of the tower walls. The towers are simply roofed with slabs of granite. The great, peaked roof of the central mass is unbroken, except by the line of tall dormers at its base and the tall, clustered chimneys which break through it midway. In detail, the work is scarcely so fortunate as in the mass. The dormers (page 163) seem too tall for the arcade beneath them, and when these features re-appear on the south side, the fault is corrected, not by dropping the dormers, but by elongating the arcade. Though the delicate enrichment of the cornice has in itself much elegance and is well disposed, it lacks emphasis, as if the designer had forgotten to allow for the difficulties of his material; and the rich shell frieze looks almost like an ornament merely incised, instead of modeled. This defect disappears altogether on the south side, where the ornament

has the relief of high light and deeply pitted shade, and an effect of rugged richness takes the place of intricate intaglio (page 164). What remains most admirable, however, in this exterior work, is the skill with which the jumble of things below has been cleared up into a harmonious relation of parts above, and differences which seemed adequate only to confuse monotony have been made to yield a real emphasis and a true variety. On the court side of the building, the statute about styles did not apply, Mr. Eidlitz's design has been carried out, and the contrast with the street side is striking. The breadth and simplicity which constitute the distinction of Mr. Richardson's work, in comparison with what is below it, have here been carried even further; perhaps the simplicity has been carried too far. The same arcade re-appears, though here it is not merely a relief to the work below it, but a tolerably distinct protest against that work. The whole aspect of the upper wall is plain even to rudeness. It is a studied plainness, however, and serves as a foil to the dormers (page 165), which, as upon the other side, are the richest and most elaborately wrought features of the work.

If the aim of Mr. Richardson's work is picturesque stateliness, that of Mr. Eidlitz's is as plainly monumental dignity.

After all, the exterior of the new Capitol is but an example of architectural tinkering. It is interesting to see what skill can do toward redeeming a building so far gone as the Albany Capitol, but it is almost pitiful to think in how great a degree skill must be wasted upon it. Even the technical unity of pure style could not have been preserved here. Still less can the exterior ever have the unity to which style is but a means, the unity of a realized idea, when the artists must superimpose their ideas

upon three stories innocent of idea. The interest of the building must remain in its parts. The real opportunities of the architects were offered in the interior, in the chambers, which were determined only in dimensions and position, and it is in these that their real successes must be looked for. Mr. Richardson's opportunity will come in the Senate chamber and the Executive chamber, which are yet to be built, the former to take the position in the south center which corresponds to that of the Assembly chamber in the north center, and the latter to occupy one of the corner pavilions. The designs for the former are completed and show that in this more dignified and more sequestered of the two chambers magnitude is not especially sought for.

As this paper deals only with what may actually be seen in Albany, it is enough to say here that these designs aim at an impression of elegance through rich color and intricate form, and that the attempt gives

every promise of being successful. Meanwhile Mr. Eidlitz's interior work stands done and, without doubt, gives the building at present its chief architectural interest. It comprises the whole of the completed north center, and includes the staircase, the Court of Appeals room (the temporary Senate chamber) with its corridor, and the Assembly chamber, besides a large number of subordinate rooms. Even here, except in the Assembly chamber itself, one feels that the thought of the architect has not been freely embodied, and that it can only be darkly apprehended through the limitations which

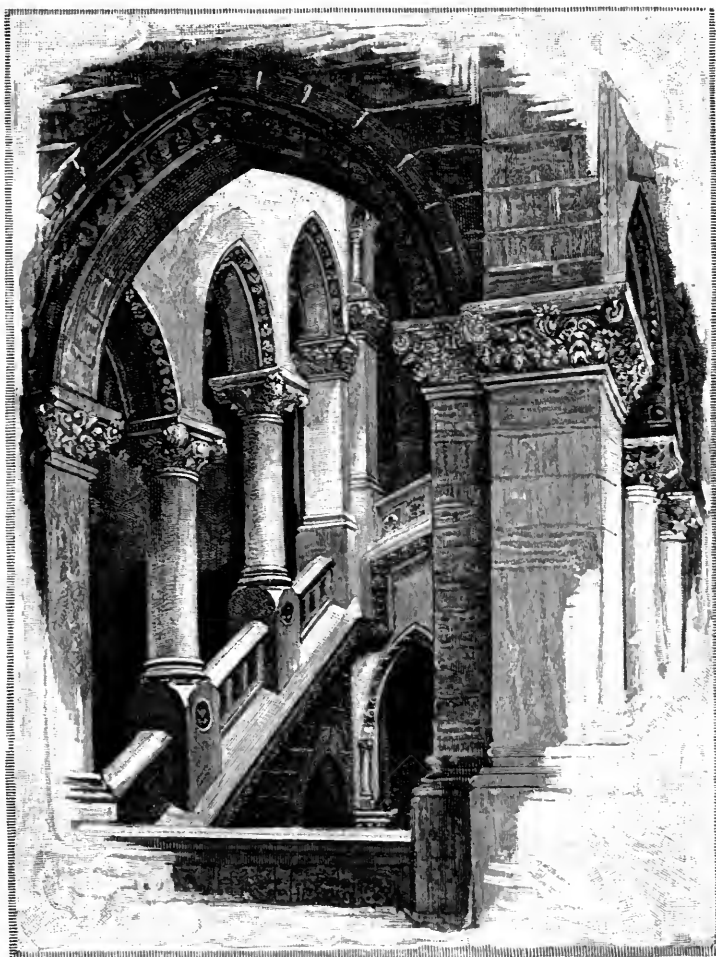

STAIRCASE, NEW CAPITOL.

beset it. The main entrance hall which will one day be fronted by a richly recessed porch, was committed altogether, for it was already built. This is the hall of the granite piers, rude without vigor, and unmodeled save for

one huge roll at each angle. Perhaps as sharp a contrast as the building offers between the old and the new dispensations of its architecture is that between this entrance hall and the corridor of the Court of Appeals room on the floor above it. The corridor (page 166) is even simpler in treatment than the entrance hall. Its forms have been left plain because it was conceived in color, and resplendence and intricacy of color are most effective and most appreciable when applied to fair surfaces and simple masses. The corridor is 140 feet long by 20 wide and perhaps 25 high, and extends along the whole "court side" of the north center. It is lighted by seven large windows opening on the court, which naturally divide it into bays of 20 feet square. Each bay is bounded by piers between which arches are turned, and these arches sustain a low and ribless groined vault. The piers themselves are plain but for a bead at the angle. Nothing could well be simpler than this arrange-

ment, but its simplicity is neither rude nor affected. It is the structural basis of a most sumptuous and elaborate decoration in color. The piers are covered with a damask of red upon umber. The angle moldings are solidly gilded. The crimson wall screen on both sides is overlaid with a simple reticulation of gold lines framing ornaments in yellow. The whole vault is gilded and upon its ground of gold, traversing each face of the vault, is a series of bands of minute ornament in brown and scarlet and deep blue. The method—this close mosaic of minute quantities of crude color—is entirely Oriental; and the effect is Oriental also. The varying surfaces of the vaulting, each covered with fretted gold, give a vista, lengthened by the dwindling arches, alive with flashing lights and shimmering shadows; and under the iridescent ceiling there seems' always to hang a luminous haze. In the quality of pure splendor there is no architectural decoration in this country

which is comparable to this. The Court of Appeals room (page 168), to which this gorgeous corridor gives access, has a richness as sober as the other is riotous. The room is a square of sixty feet with a height of twenty-five. It is subdivided into two parallelograms, one twice the width of the other, by a line of red granite columns carrying with broad low arches a marble wall. The walls are of sandstone, visible in some places but covered in most with a decoration in deep red, and with the tall wainscoting of oak which occupies the wall above the dado of sandstone. The ceiling

is a superb construction in carved oak, carried on a system of beams diminishing in size from the great girders, supported by great braces, which stretch from wall to wall, and finally closed by oaken panels. These panels in the shadow of these deep recesses are profusely carved with foliage in high relief, and the panels of the wainscoting are profusely carved in diaper. The chief elements in the harmony of the room are thus crimson and oak. There is a temporary discord in



DOWN THE STAIRCASE.

this harmony, and a temporary drawback to one's complete enjoyment of the room in the glare of the white marble wall, to be softened ultimately with a diapered decoration in color. With this exception the room is already as delightful in color as it is rich, grave and impressive in design; and neither the rich modeling of the forms throughout it, nor its weight of color, are carried anywhere so far as to disturb its leading character of simple dignity.

In the staircase (page 169) one finds that there are still allowances to be made. It is crowded into a well which is not only much too small for such a purpose, but is virtually lighted only from the top. Though the whole opening has been glazed, the detail of the lower flights cannot be well seen, and the general plan is perforce cramped and undignified. But the staircase itself, which is built of sandstone, and carried between the outer wall of the well and an inner wall, pierced in each flight and at each landing with pointed arches, is a vigorous and scholarly piece of work.

Over the Court of Appeals room and its corridor, reaching eighty-four feet from wall to wall of the "North Center" and occupying with its dependencies the whole 140 feet of the length of it as well, is the Assembly chamber. Here at last, it must seem to the spectators of his work, however it may seem to himself, that the architect has finally rid himself of trammels, and instead of attacking the insoluble problem how to create a soul under the ribs of "the original design" has been empowered to set his own free thought before us. It is only when

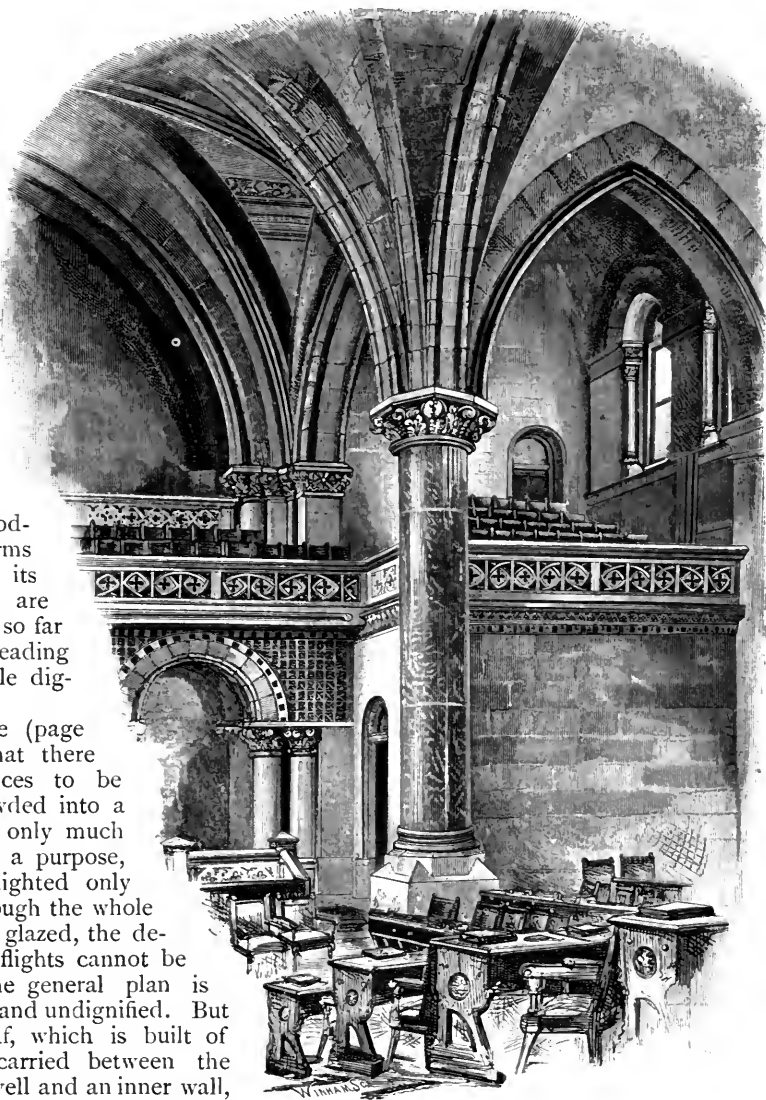

ASSEMBLY CHAMBER, WEST END.

one considers the limitations imposed by the walls and floors that he sees how very different is the adjustment to this place of the architect's conception of a legislative hall from the unhampered embodiment of such a conception in stone. His problem was: given a parallelogram (page 172), to inscribe in it the lines of an Assembly chamber.

The central space, 84×55, which becomes the Assembly chamber proper, is thus in ecclesiastical language the transept of a room of which the nave is 140 feet long, in five bays, and the aisles are but of one bay at

each end. The extreme length appears only in the galleries of the nave, which are carried over the lobbies. In front of the public gallery at the Speaker's end, and below it, is the reporters' gallery. On either hand of this again, lower still and still further advanced, filling the square bays of the aisles, are ladies' galleries. Four great red granite shafts, four feet thick, bound the central bay. From their marble capitals rise and ramify the ribs and arches of six bays, differing in height, in area, and in shape, forming an ordered hierarchy leading up to the keystone of the central vault.

The perspective of the room is so arranged that from the entrance one looks through the large end of the telescope, as it were, down vistas framed in arches narrowing and vaults hanging lower as they recede, from the great red pillars on either hand, along the vast and ever-varying surfaces of the ceilings, their creamy sandstone faces divided by the sweeping lines of the deeper-toned ribs and arches

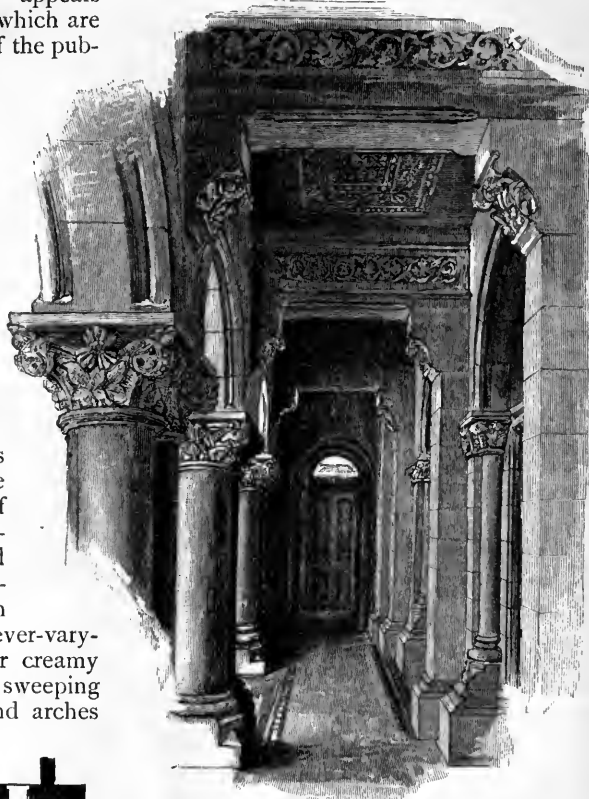

UNDER THE REPORTERS' GALLERY.

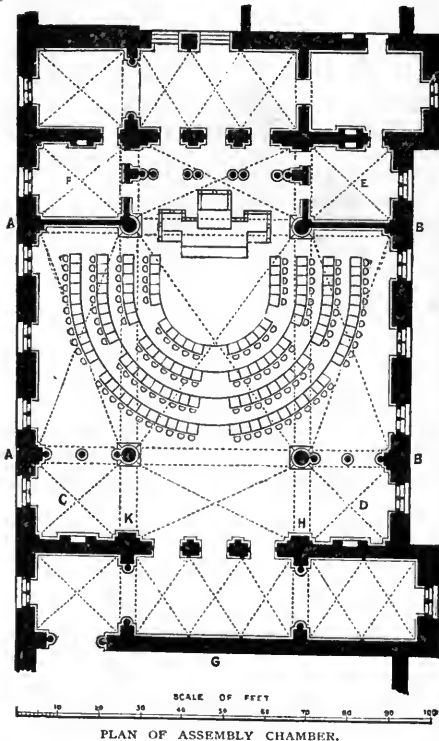

that uphold them, and fretted with wide belts of ornament climbing their climbing courses, touched with the gleam of gold and standing out from hollows filled with deep ultramarine and burning vermilion, to "the dark backward and abysm" of the remotest vault. Through the lower arches one sees the openings of the windows which flood the transept, not with the dim, religious light of old cathedrals, but with naked and open daylight. Around them wheel the intricate arabesques of their arches defined against a ground of vermilion and circled with bands of gold. Above and between the lower three, beneath the broad belt which is some day to carry a sculptured procession, the whole wall is covered with arabesques in a field of dull red. Above the upper arcade are glimpses of the draperies and the attitudes of colossal painted figures.

One feels at once in this great stone room that he is in the presence of a noble monument, and that in what a musician would call the "dispersed harmony" of this

hierarchy of ordered masses, and this balance and opposition of sweeping curves there has been achieved in the America of the nineteenth century a work not unworthy to be compared with what has been done in more famous building ages. When the shock of such an impression has subsided and he has time to examine the sources of this effect, he finds them in the general conception of the room rather than in any of its parts or in any aggregation of them less than the whole. Here is a distinctly Gothic room, which in its plan has so many resemblances to a mediæval church that it cannot be described without using the terms of ecclesiology, which yet has probably never reminded a single visitor of a church. Its civic character has been impressed upon it by the force of design alone, and mainly by the modeling of its masses, after the noble arrangement which this modeling assists. There is a vigor in it which reminds one of Romanesque or early Gothic, but it has none of the rudeness of Romanesque vaulted

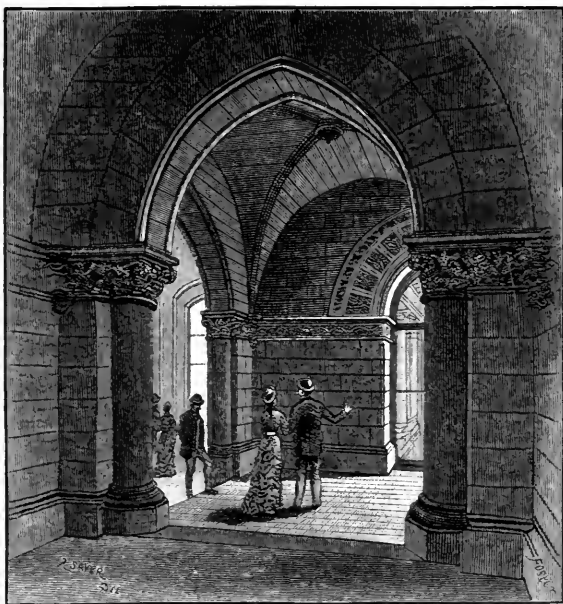

ARCH IN THE LOBBY.

This completeness, however, nowhere degenerates into the attenuation that comes of excessive subdivision—nowhere into a loss of that sense of power which belongs to unheven masses fulfilling structural necessities. There is nothing here of which one may say: "Twere to consider too curiously, to consider so." Neither is there anything of that ascetic intensity which most of all has set its stamp upon the ecclesiastical work of the Middle Ages. This work is as daylit as Grecian Doric. It is frank and manly, and it is eminently alive—distinctly a product of our time.

The disposition and the modeling of the parts in the Assembly chamber determine its character, and whatever is done after this but enhances an inherent effect. There is a wealth of carved work, modeled and incised, which uniformly accentuates and enriches and nowhere enfeebles or disguises the powerful masses, the leading lines, and the great untroubled spaces. If the masses lacked emphasis or the leading lines were less pronounced, or if the ornament itself were less judiciously designed and disposed, the architectural features of the room would disappear under the profusion which now only enriches them. Mr. Ruskin has laid it down that ornament cannot be overcharged so long as it is good. This may be only Mr. Ruskin's way of saying that ornament cannot be overcharged so long as it remains



CAP OF LARGE COLUMN, ASSEMBLY ROOM.

architecture and none of the tentative imperfection of early Gothic work. Except in one conspicuous instance, the structure is completely developed, and complete development is the mark of perfected Gothic.

ornamental; but it is quite certain that the more lavishly ornament is applied, the greater the necessity that the structure which it tends to dominate instead of decorating should starkly and unmistakably assert itself. The most striking thing about the detail is also the most striking thing everywhere in the treatment of the monument, and the one indispensable factor in its success: it is the fact that the design evidently and everywhere proceeds from the whole to the parts. Parts are not put together to simulate a whole; they are developed from the whole. It is an evolution from the homogeneous, but to the homogeneous also. The detail, with such exceptions as will readily occur to the reader, is but a modification, a literal detailing for a special service, of the mass. Accordingly, the detail, the strength of which is its absolute architectural appropriateness, beautiful as much of it is in itself, cannot fairly be judged by itself. All of it is highly "conventionalized," that is to say, is modified from a natural type to meet the exigencies of a particular situation,—which is as different a thing as possible

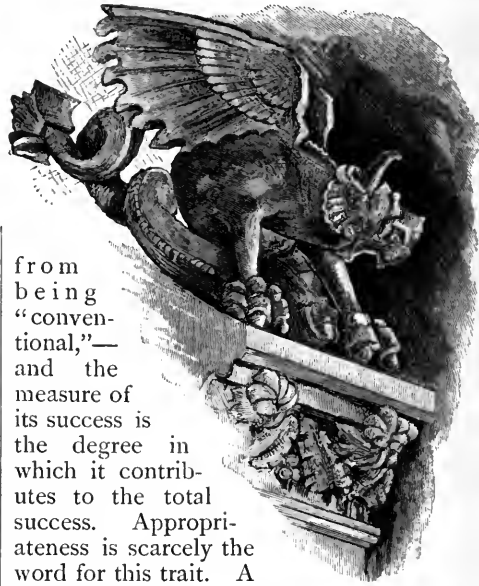

GRIFFIN ON FIRE-PLACE.

from being "conventional,"—and the measure of its success is the degree in which it contributes to the total success. Appropriateness is scarcely the word for this trait. A saying of Wordsworth about Goethe's poetry has lately been quoted which supplies a better. "Goethe," he said, "is not inevitable; not inevitable enough."

This detail is inevitable, because the artist has been so possessed with the idea of the whole that the parts follow necessarily. If this is true, it follows that we need not concern ourselves with the question of the absolute originality of the detail, for an artist sufficiently possessed by the idea of the whole will make or find an expression of it in the parts which shall fulfill this great condition of inevitableness. What is true of modeled detail is true of color. As the carved decoration follows the structure, so the colored decoration follows the carved decoration, and, of course excepting the mural pictures by the late Mr. William M. Hunt, cannot be conceived apart from it. It will be seen that although the mass of the

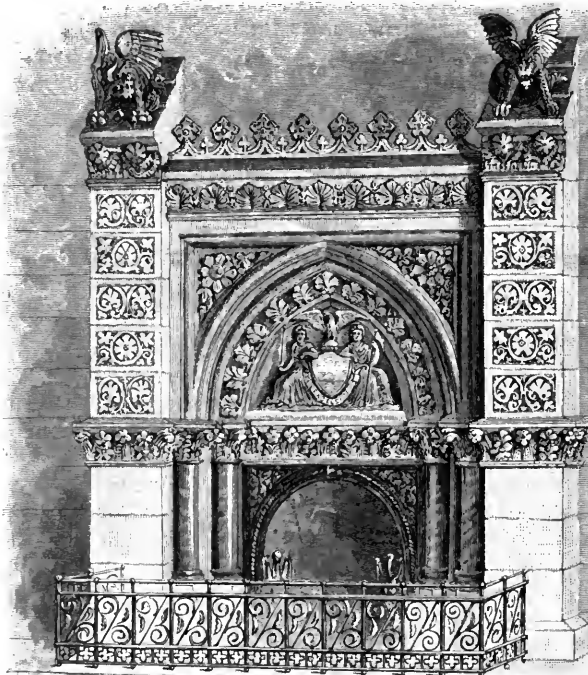

FIRE-PLACE.

work is of creamy sandstone, the system of decoration, which includes gold, red and blue alone, is pitched in a very high key for an accompaniment to mural paintings which are demanded to be the most brilliant and conspicuous parts of the system.

This description of Mr. Hunt's mural paintings is taken from an article in the "American Architect":

"The space which each is to occupy is bounded by the line of the vault above and at the sides, and by the window heads below, and is some fifteen by forty-five feet in area. The subjects are allegories. That on the northern wall (the axis of the room is east and west) represents the Flight of Night. The Queen of Night is driving before the dawn, charioted on clouds drawn by three plunging horses, one white, one black, one red, without other visible restraint than that of a swarthy guide, who floats at the left of the picture, and whose hand is lightly laid upon the head of the outermost horse. At the right of the goddess, and in deep shade, is the recumbent figure of a sleeping mother with a sleeping child upon her breast. The other picture is equally simple in composition. The discoverer stands upright in a boat, dark against a sunset sky, Fortune erect behind him trimming the sail with her lifted left hand while her right holds the tiller. The boat is rising to a sea, and is attended by Hope at the prow with one arm resting on it and one pointing forward; Faith, whose face is buried in her arms, and who is floating with the tide, and Science unrolling a chart at the side."

These pictures may be discussed either as pictures or as mural decorations; but in either aspect, it must be a primary requisite and surely one of the hardest to fulfill that figures colossal in scale, as these are, should be so largely conceived and painted that they demand and deserve to be colossal. No more severe penalty could be inflicted upon an ordinary producer of figure subjects than that he should paint a group of figures twelve feet high on the stone wall of this transept. In this essential, certainly Mr. Hunt's work is triumphantly successful. The figures are not exaggerated into bigness; they are monumentally imagined, and nobly grouped. It may be said that they are primarily pictures and not decorations, and that if they were less complete pictures they would be more successful decorations. Until the scaffoldings were struck the painter had no opportunity of judging the result in color of his experiment of painting a picture to be lighted

from underneath, or of knowing how nearly his vigorous and luminous work would live up to the splendors of pure color by which it is surrounded. If he had had such an opportunity it may fairly be conjectured that he would have given his work a character more rigid and archaic in drawing, and both in drawing and in color made it more strictly a mural mosaic.

Whatever the success of this particular experiment may prove to be in the employment of eminent painters and sculptors in purely architectural decoration, and it is surely so far successful already as to be full of encouragement, the fact of that employment must be gratifying to all people who hope for a national monumental art. The architecture at least is secure. One can look forward to a time in which the session laws



A CLUSTERED PIER.

of 1879 shall be repealed or forgotten, and even veto messages are no longer read or regarded, when this Assembly chamber shall chiefly cause this generation of New Yorkers to be held in honorable memory by that posterity, for the reproaches of which, on account of the desecration of the capitol by architectural vandals, the chapters of architects have solemnly washed their hands of any responsibility. Even before posterity arrives, it may be hoped that the remonstrants will regret that what is now pretty generally admitted to be, or rather to comprise, the most monumental and most honorable work of public architecture which this country has to show for itself, should be absolutely the only work of public architecture, the erection of which has encoun-

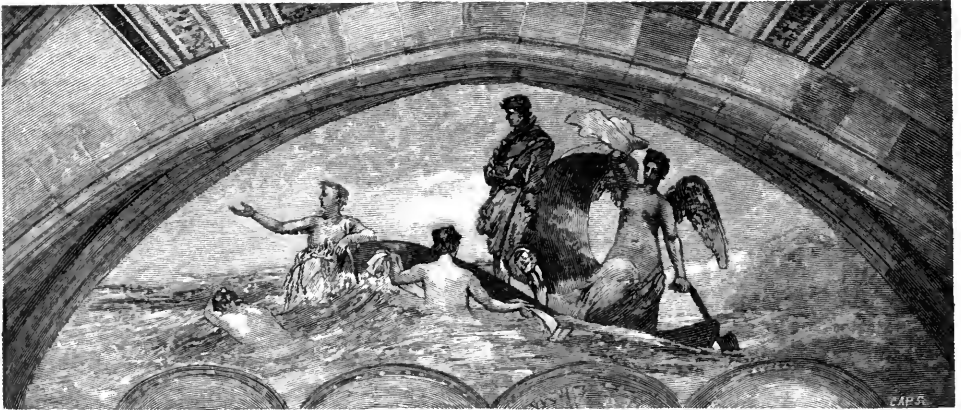

"THE DISCOVERER." (MURAL PAINTING IN THE CAPITOL AT ALBANY, BY THE LATE WILLIAM M. HUNT.)

tered the organized opposition of the body of architects and called out a formal protest in favor of continuing the commonplace level of trades-union work. If posterity should happen to contain any architectural purists, or any architectural practitioners governed by the same "received rules of art," as those which the chapters uphold, we cannot expect them to approve even of Mr. Eidlitz's Assembly chamber. For even the Assembly chamber exhibits a mixture of styles. In truth, the main academic interest of the Assembly chamber is the union in it of Gothic architecture and Saracenic decoration. Not only is the whole method of applying color the Oriental method, that is to say, the production of "tone" by the juxtaposition of positive colors rather than by the mixture of pigments, and by the application of color in different planes of surface; but the modeled ornament which alone is found in mediæval architecture is modified in innumerable instances into the flat incised

arabesques, of simple outline, which make alive the color by which they are enriched. The decoration of the ceiling and of the walls owes its peculiar vitality to the excavation of the surfaces. The incised decoration of the walls, of the gallery girders and of the impost is distinctly Moorish in method and feeling, and some of it even in form. We have said that there was one instance in which the architecture failed of that full development of the structure in virtue of which it became Gothic. In fact there are at least two, but what was then meant was the arrested development, at the stage of smooth cylinders, of the great granite columns (page 173). The full Gothic development of these columns would have required of them to prefigure in their forms the organization of the vault above them, and would have made of each a clustered pier instead of the classic column, the form of which they now take. This is a defect, not because it is classic, but because it is rudimentary, and



"THE FLIGHT OF NIGHT," BY THE LATE WILLIAM M. HUNT.

moreover because these great, shining shafts attract attention and admiration partly for their own sakes, and not entirely, as every other member of the architecture does, for their contribution to the whole. Compare this "classic" rudeness with the treatment of the pier (page 175) from which rises the arch behind the Speaker's chair, and, which is perhaps the most admirable single piece of Gothic modeling, that is to say of poetic logic, in the chamber. In this clustered pier, the large transverse and the smaller longitudinal arch and even the rib of the vault are

even in the given parallelogram, were already the elements of this power of mass and grace of detail, of all this life and movement and variety. From the idea of the whole proceeded this clear division, this interdependency of parts, this graduated subordination of the less to the greater of these, and of all to the sum of all. One can scarcely insist too strongly upon this order or recur to it too often, for it is in the conception of the whole that there resides that imagination which afterward bodies forth, by dint of merely technical power and



UNDER THE LADIES' GALLERY.

all foretold. The other instance of an incomplete architectural development is furnished by the great arches, the voussiors of which merge into the wall above them without any definition of the extrados, and, indeed, with hardly a continuous line to mark their outer boundaries, while the less important arches of the wall openings are carefully and strongly emphasized.

Here, then, is the completed evolution of the germ that inhered in the ground plan which notes the fundamental conception of the Assembly chamber. Here, inscribed

technical accomplishment, the shapes of things unknown. In the Assembly chamber there has been produced what is not to be found elsewhere in this country upon the same monumental scale, and what is the rarest of achievements in modern architecture, a real and living organism. Here has been established, as truly as in a Doric temple or a thirteenth-century cathedral, an architectural type; and this is the sign, not merely of creative power in the individual designer, but of life in art. Finally, had the execution of the building from its inception been con-

fided to the architects who have been intrusted with the mitigation of some parts of it, we might have had in the whole the organic unity which can now be looked

for only in the parts, and of the pile there might have been much more to say than that it presents a noble sky-line and contains rich and ingenious detail.



A DREAM OF THE NEW ALBANY.

BROTHER ANTONIO.

In some forgotten ruler's reign,
There stood an abbey in priest-ruled Spain,
Tenanted by the jolliest friars
That ever drank from a wassail-bowl,
Or ate good dinners beside good fires,
Or prayed the sins from a dead man's soul.

They had good cellars of rare old wine;
They ate and slept on a generous plan;
Had well-stocked larders and viands fine,
And all that comforts the natural man.
They led a sordid, luxurious life—
And waged with Satan no ghostly strife;
Never, I wot, their fat knees wore
Prayerful dints in the cold stone floor.

All the brethren were past their youth;
All bore traces of deep excess;
And all had grown, in their search for truth,

Rivals in pious paunchiness.
But blowsier, broader than all the rest,
Brother Antonio stood confessed,
Rosy of visage and short of wind,
As merry a monk as ever sinned;
With prominent stomach and double chin,
And mouth to empty a wine-cask in;
Plump of body and round of limb—
You would have said, had you looked at him,

Some cherub of Rubens (himself no saint—
A glutton in color—a sot in paint)

Tempted by goodies, the greedy elf,
Had leaped from the canvas and dressed himself.

How it happened and what befell,
None of the friars would ever tell;
But Brother Antonio, hardened long
In sinful surfeit and selfish wrong,
Made all the brotherhood stand aghast
By setting boldly aside at last
Even the loose elastic rule
Of their indulgent and sordid school.
No look of pity their features wore—
Only a stern judicial gloom—
When they assembled in solemn state,
In the deep-embraured council-room,
To prove his guilt and pronounce his fate
From volumes of old monastic lore;
Grimly the gravest read his doom—
To cease from among them forevermore.
They could not redden their hands with gore;

So as the quickest and cleanest way
Of hiding his error forevermore,
They exiled him far from the light of day—

Doomed him for life to that dismal place,
The crypt, where their sainted brethren lay,

To pay the price of his dire disgrace;
And while he prayed them, with pallid face,

To lift his sentence and shrive his sin,
They opened a tomb in the wall's thick
stones,

And, shoving the former incumbent's bones
Into a corner, they pushed him in.

In vain he struggled against their might
In mortal anguish of soul and brain.

They settled the ponderous blocks aright,
Cementing them firmly in place again,
And sealed him up in his living grave
With never a friend to shrive or save;
Leaving him there in the dreary tomb
With a gourd of water, and standing room.

(He should not perish, they said, of thirst,
They would let him starve or stifle first.)

Buried alive! Abhorrent doom!

How he struggled and cursed his fate!

Left alone in that ghastly tomb

With horrible fungi and musty murk,

And nothing to do but watch and wait

For slow starvation to do its work!

Buried alive! and his soft white hands

Dug and scraped at the stubborn stones,

And he shrieked entreaties and vain com-
mands,

And vexed the silence with threats and
groans.

The vicious skeleton elbowed him,

And when he shrunk from its noisome
touch,

It seemed to follow with purpose grim

And grip his throat with a stifling clutch,

Till his starting eye-balls almost saw

Its horrible head and fleshless jaw

In luminous outline bare and stark

Against the solid and crowding dark.

The sight would a stouter heart appall,

And Brother Antonio crouched and shrunk,

And pressed his face to the rough stone
wall

In deadly fear of the skeleton monk.

It happened that on the other side

Of the catacombed wall so thick and wide,

Another houseful of holy men,

Quite removed from their neighbors' ken,

Knowing naught of their neighbors' deeds,

Scourged the flesh for the spirit's good,

Sung their matins and told their beads,—

A happy and prosperous brotherhood.

Much did these excellent brothers grieve

That none among them was quite a saint,

And morn and midnight and noon and

eve,

They prayed with humble and heart-felt
plaint

That one of their order, gone before,
Would deign to visit the earth once more
And be their teacher to help and save
With wisdom brought from beyond the
grave.

Musing on this and many more

Similar subjects of ghostly lore,

One evening Brother Filippo took

His frugal taper and missal-book,

And stole away by the turret stair

For a secret season of silent prayer;

But he bethought him before he went

Into his cell's chill banishment,

Of a cobwebbed flagon rare and old—

A famous vintage which long ago

He had hidden away in the dust and
mold

Of the dim and shadowy crypt below.

Little he cared for specters grim

With glaring eye-holes and hollow breast—

Never a ghost had troubled him;

And he followed fearless his secret quest

Where, far from the wholesome light of
day,

His predecessors were laid away

So long ago that they paved the stones

With a basso-relievo of moldy bones.

And as he quietly picked his way

Over his sainted brethren's clay

(Or, stating it more correctly, lime),

And mused on the changes of life and
time,

To his pondering soul it must have seemed,
While the flickering flare of his taper

gleamed

On mortal relics and mildewed stones,

That the one fixed fact in the world was
bones.

There were bones in many and quaint de-
signs;

In rows and pyramids, squares and lines,

Curves and angles and wings and lyres;

Droll wheel-patterns with skulls for hubs,

Ribs for felloes and spines for tires;

Cheerful fancies of hearts and clubs

(These in honor of long-past games

When these relics wore skins and names);

Bones in triplets and bones in pairs,

Arcs and circles, rosettes and squares—

Bones in every position placed,

Bones on the most abounding plan—

Never so vast a number graced

The happiest dream of a medical man.

And skulls! they met him on every side,
Spectral and grisly and vacant-eyed;

Skulls above him, around, beneath,
 In every possible stage of teeth;
 Some had regular rows of pearls,
 Some were fanged like a savage beast,
 While some had cuspids like fair young
 girls'—
 White as rice-grains; and there was one
 Uncommonly old and holy priest,

Hark!
 The friar turned with a nervous start
 And a sudden plunge of his shrinking
 heart.
 From his jocund nose and his rosy jowl
 Ebbd in a moment the rich red blood,
 And terror struck to his inmost soul,
 As *thud—thud—thud—thud*

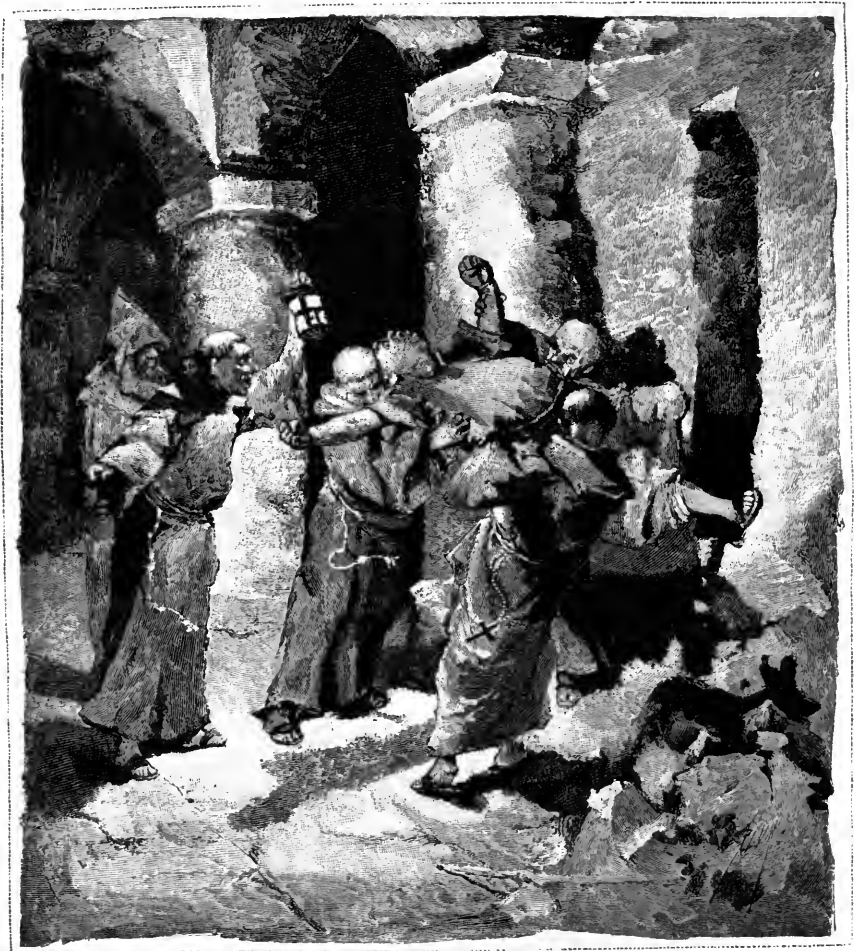

"IN VAIN HE STRUGGLED AGAINST THEIR MIGHT."

With teeth worn level by life's long feast,
 And a calm expression of work well done.
 But Brother Filippo faced the throng
 Fearless, and mused, as he stole along,
 How strange, when life is alert and glad,
 And death is dreary and cold and dull,
 That living faces are mostly sad,
 And nothing grins like a dead man's
 skull!

Came four dull sounds from a walled-up
 tomb,
 Smiting his sense like the strokes of doom.
 His very skull-cap shrunk appalled;
 Doubtless his hair would have risen straight
 Except that his head was shiny-bald—
 Bald as a biscuit, by time or fate;
 Froze his heart with a deathly chill;
 Died on his lips the mumbled prayer.

His jaw dropped wide and his pulse stood still

With a sudden and awful sense of scare,
And down on the damp unfriendly ground
He dropped in a deep and breathless
swound.

Whether the touch of dead men's bones,
Or the solid whack on the cruel stones
Restored his senses, he rallied soon,
And with many a tumble, wrench and
sprain—

His haste and terror contemning pain—
(His light was out and there shone no
moon)

He scrambled and struggled, bruised and
lame,

Back by the crooked way he came,—
The winding vault and the steep stone
stair,

Leading to life and light and air,—
Losing all he could leave behind,
Taper, and sandals and presence of mind.

The brothers gathered with spade and pick—
And something of nervous dread, withal—
And lifting the cobwebs dense and thick,
They pried a stone from the massive wall,
And lo! in answer to all their quest,—
Pale with fasting, with terror faint,
His white hands folded across his breast,—
He stood discovered—their prayed-for saint!

Whatever had been Antonio's crime,
He was always cunning, old or young,
And he saw that this was a proper time
To cast up his eyes and hold his tongue.

They lifted him gently with many prayers,
This new-fledged saint, from his stone
cocoon;

They carried him tenderly up the stairs
With faces of awe-struck joy—and soon
They made him splendid with garments
brave,



"LITTLE HE CARED FOR SPECTERS GRIM."

Warned him with cordials rich and strong,
And sculptured arches and stately nave
Sent back the strains of their welcome-
song.

Sobered by danger and fear and grief,—
For even friars from these may learn,—
Brother Antonio vowed to turn
Over a brand-new moral leaf.

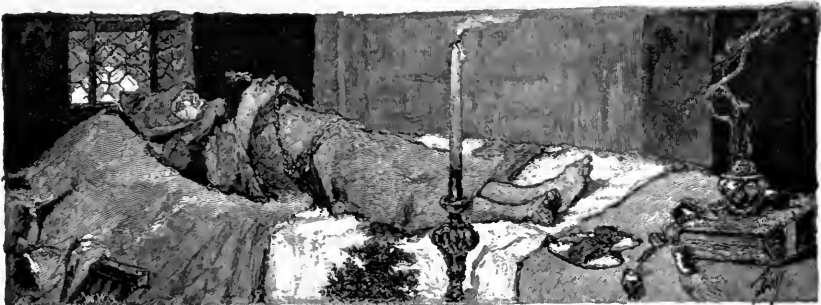

"CHILL AND SILENT THE DEAD MONK LAY."

To be devoted, sincere and good,
 And live as a godly friar should.
 He prayed and studied and fasted much;
 The fame of his saintship circled wide;
 The sick were brought for his healing
 touch
 From the furthest bound of the country-
 side;
 The simple peasantry far and near
 Held him holy; and young and old
 Sought his counsel with faith sincere,
 And, stinting their stomachs of needed
 bread,
 Bought his blessing for so much gold,
 And half believed he could raise the
 dead.

But sudden conversions seldom last;
 And ere a year of his saintship passed,
 In spite of vigils and prayers galore,
 Brother Antonio fell once more—
 Heavier, harder, deeper, lower,
 Farther and worse than he did before.
 And the sorrowing brethren, shocked and
 grieved
 To find how sore they had been deceived,
 Looked upon him as one accursed—
 No saint but a doubly sinful man;
 And remembering how they had found him
 first,
 Could think of no surer or better plan,
 To cleanse their skirts of this dismal stain,
 Than to put him back in his hole again.

So, after vespers, they took him down
 Where the broken tomb was gaping wide;
 The resident skeleton tall and brown,
 And the empty water-gourd still inside
 (The stone had never since been replaced);
 And they clad him again in his mildewed
 gown,
 With the hempen rope's-end about the
 waist,—
 The same that when he arrived he wore,—
 And plastered him in as he was before,
 With his marrowless enemy stark and grim
 And the ravenous rats to companion him.

Meantime the brothers who doomed him
 first
 Had seldom mentioned his awful fate;
 His name among them had been accused
 And rarely heard in his former home.
 Only genial Brother Jerome
 Missed and mourned for his buried mate.

It happened that on the same spring day
 When the guilty monk, for the second
 time,

Had been in the catacomb sealed away
 To expiate and repent his crime,
 Gentle Brother Jerome had died,—
 Having pined and pined since the leaves
 turned brown;
 And now, as the moon began to rise
 And scatter the light from her silver crown
 Over the dewy world outside,
 His brethren gathered to bear him down
 And lay him away to skeletonize.

Under the altar,—the usual way,—
 Chill and silent, the dead monk lay;
 The flickering taper's light revealed
 His dark-fringed lids in their death-sleep
 sealed,
 The marble brows with their classic line,
 The thin, high nose and the nostril fine,
 And the lips that never would open more
 In aves, paters, or holy hymns;
 And the coarse gray garment he always
 wore

Showing the lines of his rigid limbs.
 Under its frayed and faded hem
 Gaunt and pallid, his feet were seen,
 Bare—and now, for a wonder, clean;
 Earthly paths were no more for them;
 And, though not needed in other spheres,
 His half-worn sandals beside were placed.
 Two wax-like hands to his pulseless breast
 A wooden crucifix stiffly pressed,
 That hung by his rosary's beaded chain
 (Which never would reckon his prayers
 again)
 To the hempen girdle about his waist.

Dead—in his manhood's ripest prime;
 Dead—and, spite of his fifty years,
 What had he conquered from fate and
 time?
 What had he known of the worth of life?
 Never upon that lonely breast
 Had brow of sweetheart or tender wife
 Hidden in shyness or leaned for rest!
 Never a child had nestled there,
 Or tossed and tangled his glossy hair.
 A wandering breath from the chancel door
 Blew and fluttered its soft brown rings,—
 Silken-bright as in days of yore,
 When in his childhood's delightful springs,
 Thoughtless of scourges and penances,
 He ran and sported and laughed for joy
 Under the thick pomegranate trees
 Of fair Granada, a merry boy!
 Past all penance and prayer and pain,
 The look of his youth came back again.

It chanced that the gentle brother's death
 Was seized by Fate as the mournful means

Of saving Antonio's failing breath,
And bringing him back to earthly scenes.
For it often chanced that no living soul,
For months, went down in that dismal
hole,—

The last cold bedroom of all the friars,
Wherein when once they were laid to
sleep,

No call to matins or chant of choirs
Could rouse them;—down in that dismal
deep,

Far from the pure, rebuking sky,
Irreverent rodents, alert and sly,
But daring from numbers and fierce withal,
Wary as friars, and sleek no less,
Held with the relics high carnival,
And throve on the husks of holiness.

But Brother Jerome was dead—and so
His comrades gathered in mournful pairs,
Some bearing him down to the vaults be-
low,

While others followed with chants and
prayers;—

It almost seemed, ere they reached the
end,

That the monk had perished to save his
friend.

Hark!

Their pallid tapers, with wavering spark,
Only served to reveal the dark
And the skeleton heads,—a grewsome
sight,—

Which, glad of some presence besides them-
selves,

Seemed to nod in the flickering light,
And grin and gibber along the shelves.

Hark!

Was it a rat, that in yonder chink,—
Their tapers' glimmer scarce reached so
far,—

With a grim anticipatory wink,
Looked up from gnawing a fibula?
Each monk turned timidly round to see
What the cause of the noise might be,

As *thud—thud—thud—thud*,
There came a knocking that froze their
blood,

From the very tomb where long ago
They had walled up Brother Antonio!
Within, the famished and desperate saint,
Cramped by the chilly, close constraint,
Was struggling to make his presence known
By pounding for life with a stray thigh-
bone.

Each shrunk from showing before the rest
The awful terror that filled his breast;

Had there been but one, he had straight-
way fled

In a headlong panic of frantic dread,
As Brother Filippo had done, one day;
For courage, like fire, 'tis safe to say,—
Though none of the brothers the fact
would own,—

Is apt to languish when left alone.

At last the bravest of all the band—
He had the muscle and brawn of five—
Said,—crossing himself with a trembling
hand,—

“’Tis Brother Antonio, still alive!”

The wonder widened, and one and all
Fell to work at the massive wall,
While Brother Antonio's muffled tones
Urged them on from behind the stones.
At last they reached him; with pale hands
pressed

Prayerfully on his ample breast,
He stood, with his rapt eyes raised on
high,

And face with fasting and fear made wan,
Like the pallid statues that stand for aye
Niche-enshrined in the Pantheon.

Lo, a miracle! All their eyes
Opened wider with awed surprise—
Surely, none but a saint could live
Eleven long months in a hole like this!
And all were eager and glad to give
Honor to such rare holiness.

Humbly the pale and wondering throng
Pressed around with obeisance low,
Praying his pardon for all the wrong
Done in blindness so long ago.

And, as though to welcome the wise old
boy,

The rows of skulls on the narrow shelves
Grimaced and grinned in the general joy,
And talked it over among themselves.

Brother Antonio knew full well
He had cheated death by a marvel twice,
And haply the specter that shared his cell
Gave him some opportune advice.

Be that as it may, he took good heed
To mind his warnings and mend his
ways,

Atoning by righteous life and deed
For all the errors of former days;
So he lived revered as a saint should be,
And died in the odor of sanctity,
And when at last he was laid away,
His journey ended for good and all,
And nobody heard him, by night or day,
Knocking for help in the thick stone wall.

TWO VISITS TO VICTOR HUGO.

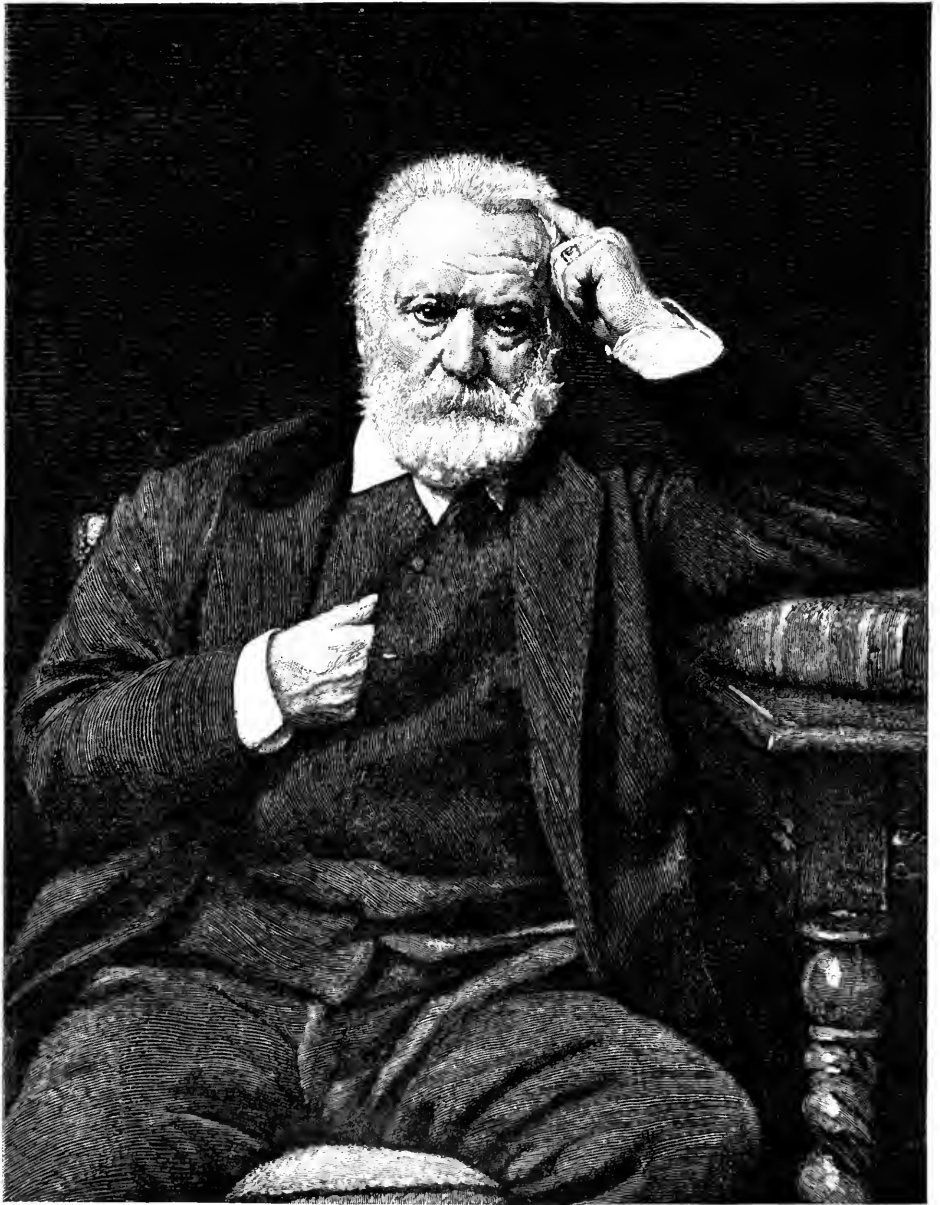

VICTOR HUGO. (ENGRAVED BY T. COLE FROM A PHOTOGRAPH OF THE PAINTING BY BONNAT.)

At the hotel where we were stopping in Paris, I made the acquaintance of a leather dealer from Texas,—a very worthy man, I doubt not, but rather loud and superfluously emphatic in his style of conversation.

“There are two men,” he said to me one day, “that I must see before leaving Paris—Victor Hugo and Renan. Do you know on what days they receive the public?”

I ventured to suggest that they did not

receive the public at all; but my leather dealer could hardly credit such a statement. The next day he applied to the American minister for letters of introduction, which the latter, for obvious reasons, refused to furnish. The Texan threatened revenge, and intimated privately to me that I need not be surprised if the minister were suddenly recalled before the end of the year. A week later he confessed to me, that with the determination "to cheek it out," he had called upon the poet without credentials, but had not been admitted.

"The girl at the door," he said good-humoredly, "kept rattling away at me for some time; but all I could make out was that the old fellow was not at home, that he was hardly ever at home, and wasn't likely to be at home for a year or so. Don't talk to me any more of French politeness. Why, a stage-driver in Texas would know better than to talk such truck to a gentleman. No, sir; they are a d— rascally set, these French, and you may tell them that I said so."

This episode inclined me to put some faith in a rumor which had reached my ears that Victor Hugo had been driven from his former house in Rue de Clichy by English and American tourists. If an illiterate Texan who frankly declared that he was unacquainted even with the titles of "Les Misérables" and "Notre Dame de Paris," was yet willing to take so much trouble to see their author, what then must be the state of mind of those countless emotional persons who have shuddered at the wickedness of Quasimodo, and wept over the impossible purity and misfortunes of Esmeralda? What obstacles would be sufficient to baffle them in their efforts to make the poet's acquaintance? A Frenchman, even though he were Victor Hugo's next-door neighbor, would hardly dare aspire to the honor of his acquaintance unless he might happen to belong to some one of the literary or political cliques of which the poet is the acknowledged head. As for myself, I should never have entertained the thought for a moment, if fortune had not conspicuously favored me.

I was sitting one evening last April in Tourguéneff's library in Paris, discussing with him the deplorable condition of Russia and the recklessness and cold-blooded cruelty displayed by the government in its prosecution of the Nihilists. Tourguéneff had just returned a few days earlier from St. Petersburg, and Paris had been very empty to me during his absence.

"I hope you will remember," he said, as I rose to take my leave, "that I am always at your disposal. I know most of the literary celebrities of Paris, and I shall be very happy either to introduce you personally or give you letters of introduction. I have no doubt, for instance, that you would take much pleasure in making the acquaintance of Alphonse Daudet, who is as charming in his private talk as he is in his novels. If you are a violent impressionist, you would perhaps like to burn incense to Zola, who, in spite of his occasional violations of good taste, is a man eminently worth knowing. Victor Hugo has recently moved away from this neighborhood, and I do not know his present address; but if you are anxious to pay him a visit, I can assure you beforehand that you will be received with much courtesy and kindness. I shall be happy to introduce you."

About a week later, I received a very delightful note from Tourguéneff, inclosing the promised letters of introduction. I learned in a roundabout way that Victor Hugo was living in Avenue d'Eylau, and that he received every evening from 9½ to 11 o'clock. The Avenue d'Eylau is an interminable and rather monotonous street, which runs from the Arc de Triomphe out toward Passy; there is nothing very Parisian about it except, perhaps, the street-venders and the military beggar with one leg, singing the Marseillaise in a hoarse voice. One feels but feebly the heart-beat of the great city in these drowsy suburbs; the stage for Passy rumbles along once every half-hour with half a dozen passengers of the miscellaneous types which one always encounters in public vehicles; but the true Parisian who haunts the boulevards and the green-rooms of the theaters, and reads his "Figaro" over his morning chocolate, is rarely seen in this neighborhood, and would undoubtedly feel very uncomfortable were he compelled to take up his abode here. And yet Victor Hugo is as genuine a Parisian as ever trod the pavement of the Boulevard des Italiens. Why then did he move away from the Rue de Clichy, where you breathe, as it were, the sublimated essence of Paris? He was a martyr to his fame. He could not protect himself against the public, who, armed with guide-books and letters of introduction, were continually intruding into his privacy; then every evening a crowd of enthusiastic friends besieged his doors, boring him with their panegyrics, demanding

autographs, recitation of verses, etc.; and in a hundred ways exhausting his heroic good-humor and his unflagging patience. The very isolation of his present residence is therefore an advantage; it takes fully an hour to reach it by omnibus from the Place de l'Opéra, and as there are no other attractions in the vicinity, the poet has, at all events, the satisfaction of knowing that those who do seek him here have made a deliberate exertion to see him, and are prompted by some deeper feeling than mere curiosity.

The house is a double, two-story stone edifice, quite unpretentious in appearance, but surrounded by a very pretty garden, in which, at the time of my visit, the rose-bushes were struggling vainly to assert themselves in spite of the cold and unpropitious season. I suppose they went by the almanac (it was about the middle of May) and paid no heed to the caprices of the weather bureau. Over the front door there was a glass canopy, presenting the shape of a hollow and obtuse pyramid. I remained standing here for a few moments, feeling a little guilty, perhaps, because I had yielded to the very impulse which I had so frequently condemned in my fellow-mortals. I was perfectly well aware that my claim on Victor Hugo was scarcely any better than that of hundreds of my compatriots; but then one always finds an excuse for not classing oneself under such categories as "the public," "tourists," and "the *ignobile vulgus*." I had at all events read some fifteen or twenty volumes of Victor Hugo's writings, and had a very definite opinion concerning their literary value. I was not a blind adorer, but, as I flattered myself, an intelligent and not unsympathetic critic. It was this latter reflection which stimulated my courage to the point where I seized hold of the bell-handle and gave a vigorous pull. An elderly woman opened the door, took my letter of introduction and showed me into the reception room. The air within was luxuriously soft and delicious; a genial wood fire was drowsing in the fireplace, and under the ceiling and along the walls about fifty candles were burning in Venetian glass chandeliers of artistic design. The room was not large, and was divided by a heavy silk curtain of a dark Pompeian red, with here and there a dash of tawny yellow. The window curtains and the tapestries of the walls and ceiling were of the same stuff and colors. A number of costly ornaments in bronze were scattered

about the room; especially conspicuous were an aged and curious-looking clock and an elephant of Japanese workmanship carrying a tower on his back. Large mirrors with bronze frames of elaborate design ornamented the walls, and two magnificent Japanese screens challenged attention by the gorgeousness of their color and their exquisite embroidery, representing a flock of cranes starting up from a swamp or field, overgrown with bulrushes. In the corner next to the door is an excellent terra cotta statuette of Victor Hugo, about three feet high. He stands resting his chin in his palm and leaning against a pillar, about the base of which are flung volumes bearing the inscriptions: "Les Misérables," "Les Orientales," "Notre Dame de Paris," etc. In another corner is placed a bronze statuette of the "French Republic," who presents a warlike and threatening appearance with her formidable helmet and armor, and her unsheathed sword. She is, however (as if to re-assure those who might be alarmed by her martial equipment), resting her elbow on the tablets of the law, upon which are inscribed the words: "Constitution de 25 Février, 1875."

I had been in the room perhaps five minutes, when a gentleman with a phenomenal crop of dark hair was ushered in, and took his seat opposite to me. He glared at me for a while in a very unfriendly fashion; then went into a corner, pulled out some slips of paper, and began to mumble something between his teeth. I concluded that he was rehearsing the speech with which he was to address the great poet. Presently he sent me a very uneasy glance, thrust his slips of paper furtively into his breast pocket, and began to march up and down the floor, apparently in great agitation. Accidentally, his eyes fell upon his own reflection in one of the long mirrors and his agitation increased; he hastily pulled from his pocket a small comb, and began to arrange his hair. Five minutes more elapsed; we heard a child's voice from the next room, apparently protesting against going to bed, and a fine persuasive bass which was exerting itself to overcome its objections. The dispute grew louder; then at some remark of the little one, the gentleman with the bass voice burst into a laugh in which several other voices joined. Finally, we heard a clatter of knives and forks, a pushing back of chairs, and the confused hum of conversation which follows the rising from the table. The folding doors were flung open, and a

small procession, headed by Victor Hugo and a handsome lady of about thirty-five, entered the *salon*. He stopped in the middle of the floor, and with great ceremony stooped to kiss her hand. I presently learned that it was his daughter-in-law, Madame Lockroy. He then glanced rapidly about him, and seeing me, advanced to meet me. He extended his hand, but looked at me half inquiringly as he said:

"Monsieur—Monsieur l'ami de M. Tourguéneff?" He had evidently forgotten my name, and did not like to refer to the letter in my presence. "M. Tourguéneff's friends," he added, more cordially, "are always welcome here. Allow me to introduce you to Madame L——, M. L——, Madame de D——"

Here followed a series of introductions, during which my name was not mentioned; I remained simply "Monsieur l'ami de M. Tourguéneff."

The gentleman with the extraordinary hair now made a profound bow, as the poet bestowed his attention upon him. I heard him speak jerkily and confusedly, and I fear that at the critical moment he forgot his rehearsed speech. Madame Lockroy, with whom I had the honor of conversing, proved to be a warm admirer of Tourguéneff, whom she called "le Victor Hugo de la Russie." I was strongly tempted to object to the phrase and to formulate my objections, but I forebore. The severe realistic vigor of Tourguéneff was to me of a far higher quality than the fantastic and capricious fertility of imagination which characterizes the author of "Les Misérables" and "Notre Dame de Paris." Such heretical opinions, however, I could hardly communicate to Madame Lockroy, and I, accordingly, contented myself with answering that Tourguéneff was *facile princeps* in Russia as Victor Hugo was in France. The discussion was continued for some time and with much animation and brilliancy on the lady's part.

Madame Lockroy is the widow of Victor Hugo's son Charles, and has lately married M. Edward Lockroy, a deputy from Paris in the Corps Législatif. She has two or three children by her first husband, and it was their voices we had heard a few moments before at the dinner table, expostulating with their grandfather about the necessity of going to bed. The grandfather idolizes them, and I am told is inclined to spoil them. They are all that is left him of his own immediate family. Both his prom-

ising sons died during their early manhood, and of his daughters, one was accidentally drowned, and the other died insane. No wonder that so large a share of his affection is concentrated upon these grandchildren upon whom the perpetuation of his race depends. They rule the house, and Victor Hugo is the willing and happy slave of these diminutive tyrants. Their step-father, M. Lockroy, is a gentleman with very animated and original features, not handsome, but of absorbing and interesting individuality. A curious effect is produced by the contrast between his rather youthful features and his white hair. He was formerly a journalist and traveled as correspondent for the pictorial press, sending home sketches and letters descriptive of his varied adventures. Once he was sent to Syria to make illustrations of the massacres of the Christians by the Mount Lebanon tribes,—a daring enterprise which came near costing him his life. M. Renan found him plundered and half dead in some miserable Mohammedan hovel, and brought him back to France. But hardly had he regained his hold on life before he started off in search of new adventures, donned the red shirt and joined the Garibaldian guerillas. He had always been consistent in his hatred and detestation of the empire, and he fought it with both pen and sword; and it is this fierce anti-imperial disposition which has made him a deputy and possibly also Victor Hugo's son-in-law.

Another member of the poet's household, and next to himself perhaps the most conspicuous one, is Madame de Drouët, a beautiful, white-haired old lady, of about sixty. She was in her early youth an actress of the Théâtre de la Renaissance, and was at that time justly famed for her beauty; her dramatic career, however, was suddenly cut off; she accompanied Victor Hugo to Guernsey when Napoleon III. exiled him, and has since been his constant companion and the presiding genius of his household.

While I had been discussing Russia and Russian literature with Madame Lockroy, the *salon* had gradually filled; the host was kept busy shaking hands, listening to flattering petitions, and kissing the gloved fingers of the ladies who came to pay their respects to him. I noticed on several occasions that this was his uniform habit; no matter who the lady was, old or young, rich or poor, he invariably stooped and pressed a light kiss upon her hand. The chivalrous ease and grace with which he performed this little

ceremony were very charming; it seemed to cost him no more effort to bend his back than if he had been twenty instead of seventy-seven years old. His voice too has all the freshness and flexible modulations of youth; not a trace of huskiness or weariness or exertion. There is, in fact, nothing in his appearance, except his close-cropped white hair and a few expressive wrinkles, to betray his age. His gray eyes look as if they concealed a deep, slumbering flame, and could flash out very fiercely when occasion required; but whenever I saw them, they looked gentle and serious, except when some sudden recollection kindled in them—a sort of reflective gleam of amused retrospect. It would be impossible to design a finer head for a poet than Victor Hugo's; and his whole robust frame sustains the proportions of this magnificent head. Nature must have been in her most lavish mood when she bestowed such exceptional gifts, both physical and mental, upon one person.

The agitated young man had just risen, and Victor Hugo beckoned me to take a seat on the sofa at his side. We talked for about five minutes about commonplace things of an entirely personal character. He does not, by the way, understand a word of English, although he was for nearly ten years a resident of the Island of Guernsey in the British Channel. It takes a Frenchman to perform such heroic feats; and French *chauvinisme* has found its sublimest representative in Victor Hugo. The only foreign language with which he is acquainted is the Spanish.

I happened, in the course of our conversation, to allude to his recent speech in the Senate on the subject of African colonization. His face immediately lighted up.

"You have read the speech?" he asked, fixing his fine eyes upon me.

I replied in the affirmative.

"It is not a mere conjecture of mine," he said; "it is the path which civilization in its progress inevitably must take."

I looked perhaps a little skeptical, and betrayed the fact that his argument, as reported in the daily papers, had not convinced me.

"Africa," he continued, raising his voice as if to enforce conviction, "will be a central arena of action for the twentieth century."

That was sufficiently startling to attract the attention of the two gentlemen, a deputy and a poet, who were standing in front of

us; they suspended their conversation and seated themselves at the other end of the lounge. The various other groups of guests followed their example and gathered around the speaker. They saw by his countenance, by the luminousness of his eyes and by his impressive gestures that he was about to commence one of his inspired harangues.

"France and England," he resumed, after a moment's pause, "are the two great civilizing powers of the world. The one represents the south,—the Latin races; the other the north,—the Gothic races. Each represents cardinal qualities, cardinal virtues, of the human race. These two powers are to take—or I may say have already taken—the destiny of Africa into their hands. France, by the conquest of Algeria, has invaded the continent from the north; England, by her annexation of the Transvaal and her colonization of the land about the Cape of Good Hope, has commenced her civilizing process from the south. Each will progress steadily, the one southward, the other northward, until they meet, at the moment when the whole vast and rich continent will have accepted their intellectual supremacy, will have yielded to the civilizing ideas which they represent."

"May I ask," I ventured to interpose, "what rôle the black aborigines are to play in this drama of civilization? Are they to accept the French and the English as their masters, or are they merely to be taught by them the arts and industries of civilized life? In either case I am afraid their fate would be a sad one; human nature is not sufficiently regenerate to sustain such ideal relations, without utilizing them to selfish advantage."

"Human nature, sir, is a great deal better than you probably imagine; and moreover, I am not speaking of the nineteenth but of the twentieth century, when mankind's standard of virtue will be higher than it is at present."

I interpreted this response as a gentle snub, but the subject interested me profoundly, and I could not refrain from repeating my question.

"Do you then believe, sir," I said, "that two races, one of which is greatly the superior of the other, can live amicably together? Will not the stronger race conquer and subdue the weaker, and place its heel upon its neck? In our Southern states, this conflict of race has for many years been waged with much bitterness, and the inevitable result seems to be that the blacks, although

they have the support of the general sentiment of the people of the North, will either have to emigrate or to accept the yoke of political thralldom and social inferiority and dependence."

"I must again remind you," he replied, "that I am speaking of the twentieth and not of the nineteenth century. Moreover, the physical differences between the various branches of the human race are in their nature evanescent. The white race represents the highest type which the human race has so far reached; and all the other races are inevitably approaching this type. *They will all in the end be white.*"

This statement nearly took my breath away.

"Do you really believe, sir?"—I began.

"*Je ne crois pas du tout,*" he interrupted me, with great emphasis. "*J'en suis sûr, monsieur,—j'en suis sûr.*"

"If you will pardon me for questioning you further, I should like to know whether this gradual bleaching of the dark races is to be accomplished by an organic evolutionary process—a sort of survival of the whitest—or by a mixture of the white and the colored peoples."

"Nature will employ both processes. There is an inherent tendency in everything created to progress toward nobler and more perfect forms. Nothing is stationary or permanently retrogressive. All imperfections, though they may serve some temporary good purpose, are necessarily transient. Thus each of the inferior races has developed to a higher state of perfection qualities in which we are comparatively deficient. The African is warm-hearted and affectionate. In his affectional nature there are splendid undeveloped possibilities. Who knows but that this new spiritual fund which the African will introduce into the civilization of the twentieth century will be the very thing that is needed to solve the social problems which to us seem insoluble. In the bosom of that great unknown world slumbers the future of mankind. Take only the nearest and most palpable results of the colonization of the continent. The poor and the miserable who now breathe in wickedness and degradation in the filthiest quarters of our overcrowded cities will fill their lungs with the wholesome air of a virgin continent. They will be purified. They will have nobler aims. With possessions and fair rewards of toil they will gain self-respect. They will lift their heads and wring the fruits of labor from the rich soil.

A more even distribution of population over a wider area will do away with much crime and wickedness, because, when every one has enough, he will have less inducement to encroach upon his neighbor's domain."

A very lean old lady who had been listening in rapt admiration here raised her voice timidly and said:

"But you surely would not want to send the poor people away from France, sir."

Her mind could not conceive of a greater misfortune than being sent away from France; even a criminal deserved a better fate than that. Victor Hugo, however, failed to see any humorous side to the question, and answered, gravely:

"Yes, I would, madam. I would send them away for their own good and that of France."

"But," resumed the old lady, shaking her small head doubtfully, "the French are utterly devoid of the colonizing spirit. An Englishman or a German may settle in a foreign land and become a good citizen there; but a Frenchman, if he has happened to make a fortune in Algeria or in America, will invariably return to Paris to spend it."

Hugo seemed for a moment puzzled by this inopportune but very sensible objection.

"Madam," he said, after a while, "the French must be *made* to have the colonizing spirit. Necessity will compel many of them to emigrate and to settle permanently in Africa."

"But the African climate," said the political gentleman,—“has it not always proved very injurious to Europeans? Is it not rather an advantage to have a black skin there,—I mean from a sanitary point of view?"

"The climate of Africa," answered our host, "is much better than its reputation. Moreover, it will improve as the land becomes civilized and cultivated. It may claim its victims, but there is no great movement which does not result in the sacrifice of a few. In the second and third generations, the Europeans will have become acclimated."

This last sentence was uttered with an intonation which indicated a full stop. The company began to converse, and I feared that the poetic harangue was definitely concluded. I therefore ventured to give vent to a reflection which had haunted me during the whole discourse.

"If you will excuse my boldness," I began, "I should like to ask you why you leave *our* continent so entirely out of all

your prophecies for the future. Why should the English and the French concentrate all their attention on Africa, as long as America has abundance of fertile land to offer the emigrant, not to speak of its mineral wealth and its climate, which, with all its drawbacks, is certainly preferable to that of Africa?"

I am not sure that I fully comprehended his reply to this question, as he spoke rather low, and the hum of conversation about me blurred, as it were, the edges of each phrase, and prevented it from fixing itself in my memory. But, as nearly as I can remember, he was of opinion that we were too closely identified with the present nineteenth century civilization to originate any really new agencies for the solution of old problems. We were no longer virgin soil. I gathered vaguely the impression that he was not fond of us and had small respect for us. It seemed to him rather an impertinence for America to aspire to the *rôle* which he, by his sovereign decree, had assigned to Africa. He made no allusion to the fact that it was an American who had made the most daring and most successful invasions into the heart of "the dark continent," but he praised the enterprise of English explorers and reproved the unambitious indolence of the French, who could allow other nations to wrest from them the glory of such important achievements.

I remember once calling Victor Hugo's attention to the fact that people of dark complexion could resist the tropical climate more easily than those of blonde complexion. Would not then the Europeans grow darker in Africa, rather than the negroes grow white? And if the races mixed, I ventured to doubt whether any really high civilization could ever be developed by a race of mulattoes and quadroons, as science and experience concurred in pronouncing the mixed races feebler, and, in most respects, inferior to the pure. These objections made no impression upon Victor Hugo. He was too sure in his cause to be disturbed by any apparent conflict between his own theories and science and experience. His dreams were so vivid that he could not help believing in their reality. And who will chide him for his loyalty to his early ideals and his contempt for the pessimistic tendencies of the present generation? I profoundly respect his daring optimism, even though I distrust his prophecies and question the soundness of his philosophic judgment.

Before taking my leave, it was my intention to obtain Victor Hugo's permission to

publish his views concerning African colonization. I accordingly asked him if I was at liberty to print anything he might have said during the evening that might interest the American public.

"I give you full permission to report my views," he answered, "and am glad of a chance to give them as wide a publicity as possible."

"We have among us, too," I said, "an old and wise man who takes the same hopeful view of the future as you do; I mean Mr. Emerson. When patriotic men become discouraged at the flagrant abuse of our free institutions which they have daily to witness,—when vulgar mediocrity and selfish ignorance seem triumphant, and culture, talent and purity are trodden in the dust,—then there is sore need of a strong and cheerful voice to tell us that this is but a passing crisis, from which we shall emerge the stronger and better for our very knowledge of evil. This is the gospel Mr. Emerson preaches at all critical times."

"Mr. Emerson," said Victor Hugo, giving the name a decidedly French cut. "Who is he? I never heard of him."

I gave a brief sketch of Mr. Emerson's life, and dwelt especially upon the profundity of his thought and his large ideal vision.

"I am glad," resumed our host when I had finished, "that you have such men in America. They are needed everywhere; but they are rare. The wise man is never a pessimist. A pessimist is a narrow-hearted, narrow-brained man, with a contracted mental horizon, who allows himself to get frightened at the first severe squall, and imagines the ship of state will founder. I challenge any of these shallow gentlemen, who are always seeing a catastrophe ahead and prophesying disaster and ruin,—I challenge them to tell me whether they can point to a single historic period which has not, in its totality, been a great advance upon its predecessors. I am sure they cannot. It is a mighty impulse which drives the world onward; and, in spite of traitors and bribe-takers and conquering and crowned criminals, it will move onward and ever onward toward higher and better states. I see in the twentieth century the sure and inevitable abolition of the great evils which now perplex us; new problems, growing out of a still more complex civilization, will then arise, and new ages will solve them."

He here turned with a friendly nod toward me, put his hand on my knee, and said: "Keep that in mind, sir. Do not forget it."

"You evidently take me to be a pessimist," I remarked, smiling.

"You betrayed your sympathy with the pessimists," he replied gravely, "and they are not deserving of sympathy. They are pitiable objects, these whimpering cynics, who imagine that the universe is out of joint because *they* have an impaired digestion. Nor have I any patience with those superior critics who, for fear of soiling their dainty hands, shirk their duties as men and citizens."

These last sentences were spoken in a familiar conversational tone, and I began to fear that the master's inspiration was temporarily exhausted. But the political gentleman, who was evidently as anxious as myself to have the prophetic monologue continued, hastened to attach the broken thread of the discourse.

"If I understood you aright," he said, "you were of opinion that this abolition of the great social evils which perplex us may be looked for in the near future. Now, we all agree that war is a monstrous evil. Do you believe that the time is near when war will be abolished?"

"I do not *believe* it, sir," answered Victor Hugo with animation, "I am absolutely sure of it. I cannot tell you the exact year and date; but I can read the signs of the times, and I know and feel the direction in which the world must inevitably develop. The gradual perfecting of all instruments of destruction will soon increase the risks of war to such a formidable extent that even the crowned criminals, who so often have wantonly precipitated the nations into these terrible conflicts, will pause before incurring such a dire responsibility. Necessity will consolidate the nations and drive those of nearest kin into a defensive alliance. Thus, the French, the Spanish, the Italian and the Greek peoples will gradually approach one another and form a Latin confederacy; and the nations of the north—the peoples of Gothic origin—will be forced to form a similar alliance; not one based upon accidental diplomatic intrigues, but upon a common nationality and a strong feeling of national kinship. The smaller and unimportant differences between the nations of the same race will then appear trifling, and the necessity of being strong will engender the very sentiment which is the only safe foundation of strength. These two confederacies will be too formidable to engage in mutual warfare without the risk of mutual destruction. Even apart from progress in real enlight-

ened sentiment which I foresee in the twentieth century, the stakes of war will be so tremendous that no people and no sovereign will be mad enough to engage in it."

I observed a certain far-away, prophetic look in the poet's eyes, as, with his head thrown backward, and his hands thrust into his pockets, he conjured up these happy visions of the world's future. He seemed to see whatever he described, and he made his listeners see it. Being anxious to fix all this fleeting imagery on paper before it should escape my memory, I immediately took my leave, and after having received a cordial invitation to return, hurried to a neighboring restaurant, where I ordered something which I did not want, merely to gain the right of monopolizing a hard chair and a small table during the next hour. It was a little after midnight when the last omnibus from Passy came jolting along. I climbed up on its top and saw under the wide canopy of the starry heavens Victor Hugo's millennial visions passing slowly in panoramic succession before my half-closed eyes.

Three weeks later, as I was about to leave Paris, I availed myself of an opportunity to be present at one of Victor Hugo's receptions. As I entered the *salon* I found myself *vis-à-vis* with a very well-known countenance—that of Louis Blanc. He was, besides myself, the only person in the room, and I had ample leisure to observe him. A small slim figure, encased in black broadcloth, a large massive head, and a kindly scholarly face—that is the first hasty outline of the personality of Louis Blanc. By way of descriptive details I might mention that his coat was very long (which circumstance gave him a semi-clerical air), that his hair was brown, sprinkled with gray, and that he had no beard, but a slight prolongation of hairy growth down into the middle of the cheek, which might be interpreted as whiskers. Victor Hugo presently entered with a lady on his arm, and five or six more couples followed. The poet, after having kissed the tips of his companion's fingers, hastened to shake hands with M. Blanc, whom he good-naturedly scolded for having neglected to come to dinner.

At that moment my attention was attracted by a lady who had just entered, and who stood at my side awaiting the end of our host's conversation with Louis Blanc. Victor Hugo also caught sight of her, and immediately grasped her hand. She was a

woman of anomalous appearance; a short black dress (of some gauzy stuff), curious black lace mittens and a generally "emancipated" air. But what especially startled me was the botanical collection on her head, consisting mostly of tulips of enormous size and screaming colors. She nearly went down on her knees before the poet as he kissed her hand, and seemed so excited that I feared her emotions would overpower her.

"I have received your book," I heard Victor Hugo say; "it is very admirable, it is excellent."

The lady suddenly turned away and wept furtively. To be praised by the greatest poet of his age,—a stone would have experienced emotion at so exceptional a fate. The fact is, however, that Victor Hugo never reads, but always praises, the books and manuscripts that are daily sent to him. He gives them to Madame de Drouët or Madame Lockroy, and asks them to pronounce judgment upon the aspirant to fame, whose soul is perhaps thrilled with the thought that Victor Hugo is at that moment admiring his lyrical or dramatic effusions.

While the happy authoress was wiping away her tears, Victor Hugo fixed his eyes upon me, at first interrogatively, then with a bright look of recognition.

"Ah, le monsieur de la revue Américaine," he said, as he shook my hand; "l'ami de M. Tourguéneff."

If I had introduced myself under any of these titles, I might perhaps have suspected a tinge of sarcasm in this persistent merging of my own personality in that of my friend. But the frank expression of his face and the cordiality with which he spoke excluded any such supposition. We talked for a few minutes about the lateness of the spring, the intensity of Parisian existence, and the revival of "Ruy Blas."

"If I remember rightly," he said, "it was you who left an engraved portrait with me some weeks ago, requesting me to add my autograph. As for the photographic views of the interior of my house of which you spoke, they would be of very small interest, because this house is new, and is in no way associated with my deeper life. On the other hand, my country house at Guernsey, where I lived for so many years during my exile, may have taken a tinge of my personality and embodies many of my favorite ideas. A series of etchings by Maxime Lalanne, representing my study, the vestibule, the red *salon*, etc., was published some

years ago, and I think, is yet easily procurable."

He was here interrupted by a servant who presented him with a very shabby card. "Tell the gentleman to come in," he said.

A young man of a threadbare appearance was seen pausing on the threshold and looking about him with a bewildered air. Victor Hugo immediately advanced and offered him his hand with a *bonhomme* which apparently took no account of his clothes. The young man remained standing near the door and began to talk very earnestly. I only heard the word "ode," pronounced four or five times with significant emphasis.

I discovered among the company several Parisian celebrities, whose photographs are exhibited in every other shop-window in the Rue de Rivoli. They were mostly men of political eminence, and, if I am not mistaken, there were present some of those gentlemen of the radical camp who are anxious to remodel society on a millennial basis. After having made an attempt to identify some of these striking physiognomies and caught detached scraps of remarks which I could not help overhearing, I stumbled upon a solitary young man with downy whiskers who sat in a corner and seemed very happy. We struck up an acquaintance, and within half an hour we were intimate. He told me with charming *naïveté* that he was a poet, that he thought Victor Hugo the greatest man that had ever lived, and that it was a pity he was a republican. He (my interlocutor) and all his family were Legitimists, and hoped to live to see the day when Henry V. would be king of France. He confided all this to me in a frank, boyish manner, never doubting that I sympathized with him. I confess I was dastardly enough to keep my republican sentiments to myself. He was so delightfully unconscious, so fresh, and sweet, and uncorrupted, that I could not find it in my heart to sow the seed of doubt among his wholesome, hereditary beliefs.

A neighbor of Victor Hugo relates, in the journal "Événement," the following anecdote of the poet, which is so characteristic that I shall take the liberty to transcribe it here.

In the year 1848, Victor Hugo lived in the Place Royale, and was in the habit of patronizing a barber named Brassier, who had his shop in the vicinity. One morning, the writer in the "Événement," whom for convenience' sake I shall name H—, entered the barber's shop, seated himself in

a chair, and elevated his chin to the proper angle, while Brassier stood sharpening his razor.

"Well, Brassier, how is business?"

"Excellent, sir, excellent! I should say it is even too good, for I don't see how I and my boys are to get through with all the engagements which we have to-day. Balls and parties everywhere! We have to dress the hair of no less than thirty ladies for to-night. Look, here is the list of their addresses."

A few days later, Mr. H—— was again seated in Brassier's chair.

"How about your thirty ladies, Brassier?"

"Don't speak of it, sir. I didn't get around to more than half of them. And in the end I shall lose a dozen or more good customers, and it is all the fault of M. Victor Hugo."

"How the fault of M. Victor Hugo? What has he to do with your clients?"

"It is just as I say, sir, and you will easily comprehend it. A few moments after you left, M. Victor Hugo entered and seated himself in this very chair. I put the napkin around his neck, seized a shaving brush, and was about to approach him, when he cried: 'Wait.' He pulled a pencil from his pocket, and began to fumble impatiently in his coat-tails and in his breast-pockets without finding what he sought. At last he discovered a piece of paper on that stand, seized it and began to write. Although I was hard pressed for time, I waited until he should have finished. But he—why he paid no more attention to me than if I had never existed, but scribbled away, and only stopped occasionally to bite his pencil. 'Well, go on, scribble away,' I said to myself. 'If you can read it yourself, you are lucky.' Such terrible scrawl! And people call him a fine writer! 'If you are at liberty, sir?' I said. 'One moment, and I shall have done,' he answered. But the moment passed, and I was still standing there with my soap-dish in my hand and my brush full of lather, and fuming with impatience. He still kept on as before, scribbling away, stopping, and raising his eyes to the ceiling. 'Pardon me, sir,' I ventured to say, 'I am very much pressed

——' 'Ah, you are in a hurry,' he replied; 'so am I'; and then he made for the door and went. 'Your hat, sir,' I cried after him. 'You are right,' he answered smiling, 'I did not think of that.' And off he went without even allowing me to shave him. 'Gentlemen, you have not a moment to lose,' I shouted to my assistants. 'You will each go to the address which I shall give you. Here is the list—well, where is the list? Wait a minute! I declare—where is that list? What have you done with the list, you rascals?' 'Sir, it was there on that stand, a little while ago.' 'There! Are you sure of that?' 'Indeed I am, sir.' Heavenly grace! only that was wanting. It was on my list that M. Victor Hugo had just been writing. It was my list, sir, which he had carried away with him, after having covered it all over with his scrawl. Do you understand now how he made me lose my customers?"

"Compose yourself, my dear Brassier," said Mr. H——. "If this scrap of paper had not been found to receive the inspiration of the poet, French literature would have lost some very fine verses. You have been the *collaborateur* of Victor Hugo, and that is no small honor."

Many years ago, while Lamartine was yet alive, Victor Hugo received a letter with the singular address: "To the Greatest Poet of the Age." Without opening it he sent it to the Rue de l'Université, where Lamartine then resided. The latter, not wishing to be outdone in generosity by his rival, returned the letter to Victor Hugo. And thus the enigmatical epistle kept going back and forth for some time, and it is not known who of the two poets concluded in the end to open it. I venture to express the belief, however, that if it had arrived in 1879 instead of in 1849, Victor Hugo would have opened it without a moment's deliberation. And he would have been justified in doing so; for, with all his mannerism, declamation and rhetorical extravagance, he is yet *facile princeps* among the singers of his age. Nature gave him a royal equipment. And although Tennyson is an incomparably better artist, his thought has neither the strength nor the sweep and fervor which characterize Victor Hugo's noblest strains.

POEMS BY AMERICAN WOMEN.

ADVENT.

My eyes are weary with the long, long watching
That sees the Advent moon grow full and wane;
My straining gaze no gleam of hope is catching,
My breath stands white and stiff against the pane.

I see the snow-wreaths lift along the meadows
Before the wind, like spirits gliding by:
When, when shall I behold the fleeing shadows!
When will the promised day-break flood the sky?

O Watchman! is there yet no sign of glory
To break the darkness at the Eastern gate?
No voice that tells again the wondrous story?
For oh, the promised bridegroom tarrys late.

The bride stands fainting now before the portal,
Where long her watch and fasting she hath
borne;
Will He not come once more, with love immortal,
To fold her close and bid her cease to mourn?

Will He not whisper words of tender blessing,
To bid her aching loneliness be stilled?
Her wants and woes and bitter wrongs redress-
ing—
To bid her love and longing all be filled?

O Watchman! speed thee up beyond the fountain:
Does nothing promise my impatient sight?
Break through the myrrh-boughs on the sacred
mountain,
Gaze up mid-heaven, and speak some sign of
light!

The stairs are dark that point toward the morn-
ing;
The dove no longer finds the rocky cleft;
No shield against the cold world's cruel scorning
For her, of home and bridegroom both bereft.

And yet her lips are fragrant with the blessing
That soothed the weary and hath warmed the
cold;
Her touch still lingers where her hands were press-
ing
The wounds of them she drew within the fold.

Her work is ready for His dear approving;
Her lamp stands burning with a steady ray;
Will He not answer to her faithful loving
And bring the darkness into perfect day?

MARIE MASON.

GOOD-BYE, SWEET DAY.

(Written for Music.)

GOOD-BYE, sweet day, good-bye!
I have so loved thee, but I cannot hold thee,
Departing like a dream, the shadows fold thee;
Slowly thy perfect beauty fades away:
Good-bye, sweet day!

Good-bye, sweet day, good-bye!
Dear were thy golden hours of tranquil splendor,
Sadly thou yieldest to the evening tender,
Who wert so fair from thy first morning ray!
Good-bye, sweet day!

Good-bye, sweet day, good-bye!
Thy glow and charm, thy smiles and tones and
glances
Vanish at last, and solemn night advances.
Ah, couldst thou yet a little longer stay!
Good-bye, sweet day!

Good-bye, sweet day, good-bye!
All thy rich gifts my grateful heart remembers,
The while I watch thy sunset's smoldering
embers
Die in the west beneath the twilight gray.
Good-bye, sweet day!

CELIA THAXTER.

BY THE HEARTH.

YOU come too late;
'Tis far on in November.
The wind strikes bleak
Upon the cheek
That careth rather to keep warm
(And where's the harm?)
Than to abate
One jot of its calm color for your sake.
Watch! See! I stir the ember
Upon my lonely hearth, and bid the fire wake.

And think you that it will?
'Tis burned, I say, to ashes.
It smolders cold
As grave-yard mold.
I wish indeed you would not blow
Upon it so!
The dead to kill.
I say, the ghosts of fires will never stir,
Nor woman lift the lashes
Of eyes wept dim, howe'er yours shine for love of
her!

Ah, sweet surprise!
I did not think such shining
Upon the gloom
Of this cold room
Could fall. Your even, strong, calm breath
Calls life from death.
The warm light lies
At your triumphant feet, faint with desire
To reach you. See! The lining
Of violet and of silver in that sheath of fire!

If you would care—
Although it is November—
I will not say
A bitter nay
To such a gift for building fires.
And though it tires
Me to think of it—I'll own to you
(If you can stir the ember)
It may be found at last, just warm enough for two!
ELIZABETH STUART PHELPS.

RYDAL WATER.

DAY'S farewell breath, scarce ruffling Windermere,
Steals on to die among the reeds that bow
To their slim shadows; and in Rydal now
Yon rosy cloud, unvexed, may see a clear,
Still vision of her loveliness appear.

Calm in the mellow air stands Silver How,
The sunshine lingering on his lifted brow,
Yet, thinly veiled, a star is throbbing near.
Sleep on now, Rydal, for at dawn the grass,
Wind-stirred, will whisper round thy Words-
worth's Seat,—

Stirred by the wind, but never more, alas!
By thy true lover's once familiar feet.
Nature, thou virgin mother breathed upon
By God, hast thou no other priestly son?
ANNIE R. ANNAN.

TRANSFIGURED.

ALMOST afraid they led her in:
(A dwarf more piteous none could find);
Withered as some weird leaf, and thin,
The woman was—and wan and blind.

Into his mirror with a smile—
Not vain to be so fair, but glad—
The South-born painter looked the while,
With eyes than Christ's alone less sad.

"Mother of God," in pale surprise
He whispered, "What am I to paint?"
A voice that sounded from the skies
Said to him: "Raphael, a saint."

She sat before him in the sun;
He scarce could look at her, and she
Was still and silent. "It is done,"
He said. "Oh, call the world to see!"

Ah, that was she in veriest truth—
Transcendent face and haloed hair;
The beauty of divinest youth,
Divinely beautiful, was there.

Herself into her picture passed—
Herself and not her poor disguise
Made up of time and dust. At last
One saw her with the Master's eyes.
S. M. B. PIATT.

MIDWINTER FLOWERS.

To E. C. S.

I HOLD you to my lips and heart, fair flowers,
Dear children of the summer and the sun,
Whose summer lives in winter were begun;
Sweet aliens from the warm June's pleasant bowers,
Mocked at by cruel winds in desolate hours,
Through which the sands of winter slowly run:
I touch your tender petals, one by one,
And miss no beauty born of summer showers.
I have a Friend who to Life's winter days
Will bring the warmth and splendor of the June,
From him ye come, yet need not speak his praise,
Since on my heart is written well that rune,
And the fine fragrance of his gentle deeds
Reveals his presence 'mong earth's common weeds.
LOUISE CHANDLER MOULTON.

PROPHECY.

The glittering darkness of the perfect night,
An hour before the break of perfect morn,
When from her slowly-lessening beauteous horn
The brilliant moon still pours a splendid light:
So glows the radiance of inspired sight,
Steadfast, serene, by weariness unworn,
And clear of every human doubt forlorn;
Keeping Faith's vigil on imperial height—
While sleeps the world below, unconscious, prone,
Drunken with things of self and slothful time—
Until Fulfilment's flood, like morning's prime,
Through wondrous gates of Promise widely-
thrown,
Rolls in majestic from zone to zone
And merges Prophecy in Light sublime.
HARRIET MCEWEN KIMBALL.

SAINT SYMPHORIEN.

(LED OUT TO MARTYRDOM: HIS MOTHER SPEAKING
FROM THE WALL.)

SYMPHORIEN! Symphorien!
Look up! the heavens are parting wide.
He waits for thee—the Crucified.
The pain is short, the palm is near.
Look up! O God! he cannot hear,
Symphorien! Symphorien!
Where is my voice? my breath is gone:
Symphorien! my son, my son!
Ah—look!—his clear eyes turn to me,
His firm, sweet, smiling lips I see.
God will be good to thee and me,
Symphorien!

Dear Lord, how long I prayed for him,
With trembling tongue, and vision dim:
For baby hands about my breast,
For baby kisses on it pressed!
Thou heardest me:—this is the rest!
Symphorien! Symphorien!
My child! my boy! it is not much,
Only a sharp and sudden touch,
Think on the Master,—not on me:
Remember His long agony.
The lictors will be merciful,
The headman's axe will not be dull,
Only one moment—then for thee
The raptures of eternity,
Symphorien!

My baby! oh, my baby boy!
A miracle of life and joy:
A rosy, careless, dimpled thing.
And now Dear Lord, be comforting!—
Martyr and saint. Let be! let be!
He must not know this agony.
Through my heart, too, the sword hath gone.
Be silent lest he hear me groan—
Symphorien! Symphorien!
One last long look: oh saint! my child.
My boy! my own!—He turned and smiled.
And now behind the crowd of spears,
The whirling dust,—he disappears.
Symphorien!

Martyr and saint? You think I care?
Oh, fools and blind! I am his mother.
What! bless the Lord and turn to prayer?
He is my child—I have no other.

No hands to clasp, no lips to kiss.
 Who talks to me of heaven's bliss?
 Symphorien! Symphorien!
 Come back! come back! Deny the Lord!
 Traitor?—Who hissed that burning word?
 I did not say it. God! be just
 I did not keep him; I am dust.
 The flesh rebels. I am his mother.
 Thou didst not give me any other.
 Thine only Son?—but I am human.
 Art thou not God?—I am a woman.
 Symphorien! Symphorien!
 Come back!

ROSE TERRY COOKE.

THE POET'S ANSWER.

"WHENCE did it come?" No conscious thought of mine

Chose out the theme, as from Carrara's stone
 The sculptor chooses the one block alone
 Best fitted to embody his divine
 Symbol of beauty. But, before one line
 Forecasts the form, as Fancy sees it shown
 Perfect, or yet a mallet chip is thrown
 Off from the mass that hides his dear design,—
 Suppose a flash of quick, electric light
 Should daze the sculptor's eye, and he should see

Step from the stone, evoked as by a spell,
 The statue of his dream, Persephone;
 So sprang my Poem forth, revealed to sight,
 But by what magic wrought, I cannot tell.
 MARGARET J. PRESTON.

THE TAMING OF THE FALCON.

The bird sits spelled upon the lithe brown wrist
 Of yonder turbaned fowler, who hath lamed
 No feathered limb, but the winged spirit tamed
 With his compelling eye. He need not twist
 The silken toil, nor set the thick-limed snare;
 He lures the wanderer with his steadfast gaze,
 It shrinks, it quails, it trembles—yet obeys,
 And lo! he has enslaved the thing of air.
 The fixed, insistent human will is lord
 Of all the earth;—but in the awful sky,
 Reigns absolute, unreached by deed or word,
 Above creation, through eternity,
 Outshining the sun's shield, the lightning's sword,
 The might of Allah's unaverted eye.

EMMA LAZARUS.

THE GRASS-WORLD.

OH, life is rife in the heart of the year
 When midsummer suns sail high;
 And under the shadow of spike and spear,
 In the depth of the daisy sky,
 There's a life unknown to the careless glance;
 And under the stillness—an airy prance,
 And slender, jointed things astir,
 And gossamer wings in a sunny whir,—
 And a world of work and dance.

Soft in its throbbing, the conscious green
 Demurely answers the breeze;
 While down in its tangle, in riotous sheen,
 The hoppers are bending their knees;
 And only a beetle, or lumbering ant,
 As he pushes a feathery spray aslant,—
 Or the sudden dip of a foraging bird,
 With its vibrant trail of the clover stirred,
 Discovers the secret haunt.

Ah, the grass-world dies in the autumn days,
 When, studded with sheaf and stack,
 The fields lie browning in sullen haze,
 And creak in the farmer's track.
 Hushed is the tumult the daisies knew,—
 The hidden sport of the supple crew;
 And lonely and dazed in the glare of day,
 The stiff-kneed hoppers refuse to play
 In the stubble that mocks the blue.
 For all things feel that the time is drear
 When life runs low in the heart of the year.
 MARY MAPES DODGE.

THE KING'S LESSON.

LOKMAN, the slave of Talmi, stood behind
 His master's table as he sat at meat;
 And oftentimes it pleased the royal mind
 With Lokman to divide some morsel sweet
 Of his abundance. It was his conceit
 One day to feed him with a melon-rind,
 Acrid and bitter, and unfit to eat;—
 This with no scornful purpose or unkind,
 But for a jest; and the king looked to see
 The slave's grimaces, but he looked in vain;
 For Lokman ate the melon placidly
 Nor of its evil taste did once complain.
 It might have been—for all was said or done—
 As sweet a fruit as ripens in the sun.

Then wonder at such patience came instead
 Of the light laughter for which Talmi planned:
 "You eat the thing, and make no sign!" he said;
 "You, that are used to dainties from my hand!"
 "Yea," said the slave, "it was my lord's command
 That I should eat; and when I have been fed
 Daily upon the fatness of the land,
 Should I for this thing be disquieted?
 Bitter or sweet, it is enough for me
 That Talmi gives it." And for this reply
 The king was pleased to make his bondsman free—
 Acknowledging a lesson learned thereby.
 "God is my king: henceforth the king shall meet
 With equal grace His bitter gifts and sweet."
 MARY BRADLEY.

UNATTAINED.

TIRED, tired and spent, the day is almost run,
 And oh, so little done!
 Above, and far beyond, far out of sight,
 Height over height,
 I know the distant hills I should have trod,—
 The hills of God,—
 Lift up their airy peaks, crest over crest,
 Where I had prest
 My faltering, weary feet, had strength been given,
 And found my Heaven.
 Yet once, ah, once, the place where now I stand
 The promised land
 Seemed to my young, rapt vision, from afar.
 The morning star
 Shone for my guidance, beckoned me along,
 As fresh and strong,
 And all untried, untired I took my way
 At break of day.
 The path looked strewn with flowers, in that white
 light,
 Each distant height
 Smiled at me like a friend,—a faithful friend,—
 Sure that the end

Would soon, ah, soon, repay with sweet redress
 All weariness.
 But when the time wore on, and in the bright
 And searching light
 Of high noonday, I lifted up my eyes,
 The purple dyes
 Through which I had descried my mountain height,
 Had vanished quite.
 Then, suddenly, I knew that I did stand
 Within the promised land
 Of youth's fair dreams and hopes; but with a thrill,
 I saw that still
 Above and far beyond, far out of sight,
 Height over height,
 Lifted the fairer hills I should have trod,—
 The hills of God!

NORA PERRY.

JUST OUT OF SIGHT.

I.

IN idle reverie one winter's day
 I watched the narrow vista of a street,
 Where crowds of men with noisy, hurrying feet
 And eager eyes went on their restless way.
 Idly I noted where the boundary lay
 At which the distance did my vision cheat;
 Past which each figure fading fast did fleet,
 And seem to melt and vanish in the gray.
 Sudden there came to me a thought, oft told,
 But newly shining then, like flash of light,—
 "This death, the dread of which turns us so cold,
 Outside of our own fears has no stronghold:
 'Tis but a boundary, past which, in white,
 Our friends are walking still, just out of sight!"

II.

"Just out of sight!" Ay, truly, that is all!
 Take comfort in the words, and be deceived
 All ye who can, and have not been bereaved!
 "Just out of sight." 'Tis easy to recall
 A face, a voice. Oh foolish words, and small
 And bitter cheer! Men have all this believed,
 And yet, in agony, to death have grieved,
 For one "just out of sight" beneath a pall!
 "Just out of sight." It means the whole of woe:
 One sudden stricken blind who loved the light;
 One starved where he had feasted day and night;
 One who was crowned, to beggary brought low;
 All this death doeth, going to and fro,
 And putting those we love "just out of sight."
 H. H.

IN THE ADIRONDACKS.

O CLOUDS and winds and streams, that go your
 way,
 Obedient to fulfill a high behest,
 Unquestioning, without or haste or rest,—
 Your only law to be and to obey,—
 O all ye beings of the earth and air
 That people these primeval solitudes,
 Where never doubt nor discontent intrudes,—
 In your divine accordance let me share;
 Lift from my soul this burden of unrest,
 Take me to your companionship; teach me
 The lesson of your rhythmic lives; to be
 At one with the great All, and in my breast
 Silence this voice, that asks forever "why,
 And whence, and where?"—unanswerable cry!
 ANNE LYNCH BOTTA.

THEIR ANGELS.

My heart is lonely as heart can be,
 And the cry of Rachel goes up from me,
 For the tender faces unforgot
 Of the little children that are not:
 Although, I know,
 They are all in the land where I shall go.

I want them close in the dear old way;
 But life goes forward and will not stay,
 And He who made it has made it right:
 Yet I miss my darlings out of my sight.
 Although, I know,
 They are all in the land where I shall go.

Only one has died. There is one small mound,
 Violet-heaped, in the sweet grave-ground;
 Twenty years they have bloomed and spread
 Over the little baby head;
 And oh! I know
 She is safe in the land where I shall go.

Not dead: only grown and gone away.
 The hair of my darling is turning gray,
 That was golden once in the days so dear,
 Over for many and many a year.
 Yet I know—I know—
 She's a child in the land where I shall go.

My bright brave boy is a grave-eyed man,
 Facing the world as a worker can;
 But I think of him now as I had him then,
 And I lay his cheek to my heart again,
 And so, I know,
 I shall have him there where we both shall go.

Out from the Father, and into life:
 Back to His breast from the ended strife,
 And the finished labor. I hear the word
 From the lips of Him who was Child and Lord,
 And I know, that so
 It shall be in the land where we all shall go.

Given back,—with the gain. The secret this
 Of the blessed Kingdom of Children is!
 My mother's arms are waiting for me;
 I shall lay my head on my father's knee;
 For so, I know,
 I'm a child myself where I shall go.

The world is troublous and hard and cold,
 And men and women grow gray and old:
 But behind the world is an inner place
 Where yet their angels behold God's face.
 And lo! we know,
 That only *the children* can see Him so!
 ADELINE D. T. WHITNEY.

THE ONLY CHOICE.

I KNOW a heart that sits upon its throne,
 Yet makes its kingdom poorer day by day;
 A queen unblest, in that it blesses none,
 And far too poor to give itself away.

And one I know hath all its sweetness given,
 A flower left empty by the thankless air,
 Yet in the losing finds its only heaven,
 Fed by the fountains of divine repair.

Ah! who can weigh our wealth against our
 death?
 Where is the justice fine of sight and touch?

So light the things we dream have dearest worth,
And those we hold for nothings worth so much.

How shall I dare then for this joy to pray,
Lest when it come it prove a grievous loss?
Or how implore that grief may pass away,
Lest thus I spurn a flower-bearing cross?

Oh, blessed tears, that cleanse the eyes for morn!
Oh, costly gains, wherein our all we lose!
Oh, rose of peace, so white with many a thorn!
Choose thou, my heart, be strong at last, and
choose.

Not yet, not yet! I cannot ask for pain,
And dare not ask the joy that blindeth me.
I cannot choose; my Father, I would fain
Ask thee for that which looks like joy to thee.
FRANCES LOUISA BUSHNELL.

THE TRYST.

IMPULSED by memory in a wayward mood,
Reluctant, yearning, with a faithless mind,
I sought once more a long neglected spot,
A wooded upland bordered by the sea,
Whose tides were swirling up the reedy sands,
Or floating noiseless in the yellow marsh.
My way was wild. The winds, awaking, smote
My face, but as I passed a ruined wall
Brambles and vines and waving blossoms dashed
A frolic-welcome, like a summer rain.
Shouldering the hills against the murky east
Stood stalwart oaks, and in the mossy sod
Below, the trembling birches whispered me,
"Not here!" I reached the silence-loving pines,
And lingered. The mists swept from wooded
hills,
And, rolling seaward, hid the anchored ships.
So, happy, dreaming an old dream again,
Of keeping tryst in secret on the knoll,
I wandered on, listening in dreamy maze
To sounds I thought familiar,—the approach
Of well-known footsteps in the leafy path,—
A murmuring voice calling me by name!
Through the pine shafts the sunless light of
dawn
Stole. Day was come. My dream would be ful-
filled!
Above the hills the sky began to blaze,
And ushering morn the west flushed rosy-red;
Then, the Sun leaping from his bed of gold,
Scattered cloud-banners, crimson, gray, and white.
There was my shadow in the leafy path
Alone,—none was to keep the tryst with me!
No voice, no step among the hills I heard.
The joyous swallows from their nestlings flew,
Mad in the light with song. Far out at sea
The white sails fluttered in the eager breeze,
But Day was silent holding tryst with me,—
My pilgrimage rewarded—faith restored.

ELIZABETH STODDARD.

FROST PICTURES.

OUT of Frost and Fire sprang Ymir,
Type of Chaos, long ago.
Mighty Odin slew the giant,
As the Norsemen know.

From the rushing blood the ocean
In swift thunderous torrents whirled,
From the ponderous carcass Odin
Carved the Mitgard world;

Of his hair made waving forests,
Of his skull the vaulted sky,
Molded from his bones the mountains
Which around us lie.

Lo, to-day, upon my window
Odin carves on every pane
(To rebuke my skeptic smiling)
A new world again.

Mountain, forest, plain and river,
Flash upon my raptured sight;
Here is Summer's perfect joyance,
There Spring's dear delight.

Ferny cliff, cascade and grotto
Glitter on the frosty pane—
Miracle the Norsemen chanted
Here is wrought again.

Who shall say the gods have left us,
Or that Odin's power is lost,
When new Mitgards rise before us
Out of Fire and Frost?
ALICE WILLIAMS BROTHERTON.

INDIAN PIPE.

DEATH in the wood,—
Death, and a scent of decay;
Death, and a horror that creeps with the blood,
And stiffens the limbs to clay;
For the rains are heavy and slow,
And the leaves are shrunken and wan,
And the winds are sobbing weary and low,
And the life of the year is gone.

Death in the wood,—
Death in its fold over fold,
Death,—that I shuddered and sank where I
stood,
At the touch of a hand so cold,—
At the touch of a hand so cold,
And the sight of a clay-white face,
For I saw the corse of the friend I loved,
And a hush fell over the place.

Death in the wood,—
Death, and a scent of decay;
Death, and a horror but half understood,
Where blank as the dead I lay;
What curse hung over the earth,
What woe to the tribes of men,
That we felt as a death what was made for a
birth,—
And a birth sinking deathward again!

Death in the wood,—
In the death-pale lips apart;
Death in a whiteness that curdled the blood,
Now black to the very heart:
The wonder by her was formed
Who stands supreme in power;
To show that life by the spirit comes,
She gave us a soulless flower!

ELAINE GOODALE.

THE JOHNS HOPKINS UNIVERSITY.

THE Johns Hopkins is the youngest, and one of the very few real, universities in America. It possesses no history, claims no distinguished sons, has indeed hardly reached the dignity of *Alma Mater*. If it is to be a giant among the intellectual agencies of our western world, it is a giant yet in its cradle. Benignant powers have smiled upon its birth, and the future opens out gloriously, with promise of success. Still, since it is an infant enterprise, any record of it must necessarily be one of plans and projects, rather than a history of accomplished deeds. However, to any one interested in the advancement of education, such record can hardly fail to be of interest.

There are few things less perfectly comprehended by the public than the distinction between a college and a university. A vague notion seems to be afloat that a college endowed by the state thereby becomes a university. If to the four years' undergraduate course of such endowed institutions, schools of law and medicine be added, all doubt fades away in the popular mind. The further addition of a school of theology or of civil engineering fixes the rightfulness of the claim in the splendor of certainty. The distinction made broadly is this: A college should be an advanced school for drill in the academic studies; it should lay a broad and solid foundation of general education, on which any superstructure of special work may be reared. To this may be added schools of law, medicine, or theology, for the professional education of the student. The university, on the contrary, does not aim to do fundamental work, nor to train for any special practical career. It encourages to original research, stimulates individual growth, and offers the conditions of a high intellectual life.

It is necessary, as Professor Gildersleeve strongly advocates, that the work hitherto done by colleges shall be redistributed, and preparatory schools made more efficient, before we grapple with the problem of American university work. There must be practically something in common between the college and the university, however great the theoretical difference may be. The distinction is delicately made by Professor Gildersleeve:

"Still the university differs, or let us say, ought to differ, from the college, inasmuch as it should be a great laboratory of systematic research. On the other hand, it differs from an academy of sciences, inasmuch as it should be a great center of instruction. To the combination and interaction of research and training, the German universities owe their efficiency and their influence; and whatever modification German methods must undergo before they can be made fruitful in our civilization, these two elements must always be associated in our highest work. True, an able explorer may be an indifferent teacher; a good teacher may not have the spirit of initiative which leads to successful investigation; but the two faculties, though not always in perfect balance, are seldom wholly divorced, and a university professor should possess both."

As a people we are disposed to multiply rather than to perfect our educational agencies. For a century or more schools and colleges have been springing up over the land; the *desideratum* has been the diffusion of a general education among the many rather than the special training of the few. And it is quite right that this should be so. For a republican people, the ideal educational system should offer to all the opportunity for laying a broad and solid foundation which shall serve equally well as a basis for a mercantile, professional, or scientific career. The instruction in schools and colleges should be fundamental, the special and higher training being otherwise provided for.

The growing demand for opportunities for special training has been here and there responded to in one way or another. Harvard has answered the call by casting off to some extent, her collegiate shackles, and assuming university freedom. Cornell and Michigan long ago adopted the university idea; and Yale has supplemented the four-year course by schools of science, and made other changes which afford her graduates facilities for further study in various departments. Some years ago, when the question of the higher education was agitated, it was discovered that the University of Virginia had, for more than fifty years, been upholding the university, in contradistinction to the college, idea; and had been tendering opportunities for study, not only in the ordinary course, but also in the more advanced classics, physics, and mathematics.

A large number of our colleges, in en-

deavoring to respond to the call for the higher education, have made a double mistake: they have endeavored to combine the advantages of both systems, and in doing so have spoiled themselves as colleges, and yet have not become universities. The university is not intended to supersede the college, but to succeed it; not to supplant it, but to supplement it. In many instances, studies have been multiplied, while the time devoted to the course has remained the same; in consequence the student has been overcrowded. Two evils have resulted from this change: the work, apart from the competence of professors and the earnestness of the student, became, necessarily, more superficial; and the pressure was relieved by docking off the course at its beginning. The standard of admission was thus gradually raised, and this, of course, advanced the age of matriculates. Thirty years ago, nineteen was the average age for graduation; now, nineteen is, in many of our colleges, the average age for matriculation. Many a young fellow, with the old standard of admission and curriculum, might have availed himself of the advantages of a college course, and been ready to enter business at nineteen, who now foregoes the course because he cannot spare the years between nineteen and twenty-three from his business career.

This, however, is a small evil when compared with the more positive harm which the change has made in those who do go to college. While the course has been advanced, in most cases the method of instruction has remained elementary: a man's work is given to the student, and at the same time he is taught, and watched, and made to recite lessons as if he were a mere boy. If he proposes to enter upon a life of business, he finds at graduation that he is no better furnished for the life before him by his advanced course than he would have been with the old system, and he has lost four of the best years of his life from his business career. If, on the other hand, he proposes to devote himself to scientific, philosophic or literary work, he finds himself at twenty-three without any training for original research,—with a large store of facts, perhaps, but still, to all intents and purposes, a boy.

Such being the evils of the hybrid system, the country is ready for a new foundation, and this the gift of a private citizen has supplied.

By the will of Johns Hopkins, a merchant of Baltimore, the sum of \$7,000,000 was

devoted to the endowment of a university and a hospital, \$3,500,000 being appropriated to each. This is the largest single endowment ever made to an institution of learning in this country. To the bequest no burdensome conditions were attached. Among the few definite provisions of the will was one requiring that all building and other expenses should be defrayed out of the income, leaving the capital untouched.

Clifton, the estate of the donor, and forming part of the bequest, contains over 300 acres, and is situated three miles from Baltimore. The conditions of the will just mentioned precluded the immediate erection of the permanent university buildings. Two large dwelling-houses on Howard street were therefore purchased and so modified as to serve the purposes of the university. To these have been added Hopkins Hall and a chemical laboratory. An additional building has just been procured. The ground floor of Hopkins Hall is devoted to a general lecture-room. Above this is the library together with small rooms for private study furnished with desks, etc. The third floor is occupied by the physiological laboratory, with other rooms for special biological and physiological research. In the rear of the lot, a very complete chemical laboratory, with office rooms, technical libraries, etc., has been erected. In connection with these buildings there is a little workshop, where a skilled instrument-maker is busy putting into execution the various mechanical devices and inventions of the professors, associates, and fellows of the university. The buildings are complete and commodious and very simple—so plain and unpretending, indeed, as to bring a smile of scorn upon the lips of the professional sight-seer, who has been used to think that education in America is nothing if not bricks and mortar. The idea is that the buildings shall form the shell, which shall grow fast enough to house the informing life of the institution.

Just what this new university was to be proved a very serious question to the trustees. The conditions of Mr. Hopkins's bequest left the determination of this matter open. The problem to be solved was how to adjust this new force so that it should be most effective and answer most pertinently the needs of the younger generation. There were already enough colleges, scientific schools, technological institutes, to meet the needs of the country. Some of these established schools were growing and thriving at the expense of others. It was altogether un-

desirable that another rival should appear. The real need in Baltimore was that the new institution should come in, first, as an organizing power which should harmonize and unite the scattered agencies already existing, making of them, not rivals but co-laborers. There is no stronger evidence of the wisdom and good feeling of the president and board of trustees of the Johns Hopkins University, than the fact that they

courses should be voluntary, and the teaching not limited to class instruction. The foundation is both old and new. In so far as each feature is borrowed from some older university, where it has been fairly tried and tested, it is old, but at the same time this particular combination of separate features has here been made for the first time. A system which had been the outgrowth of centuries of English or German national

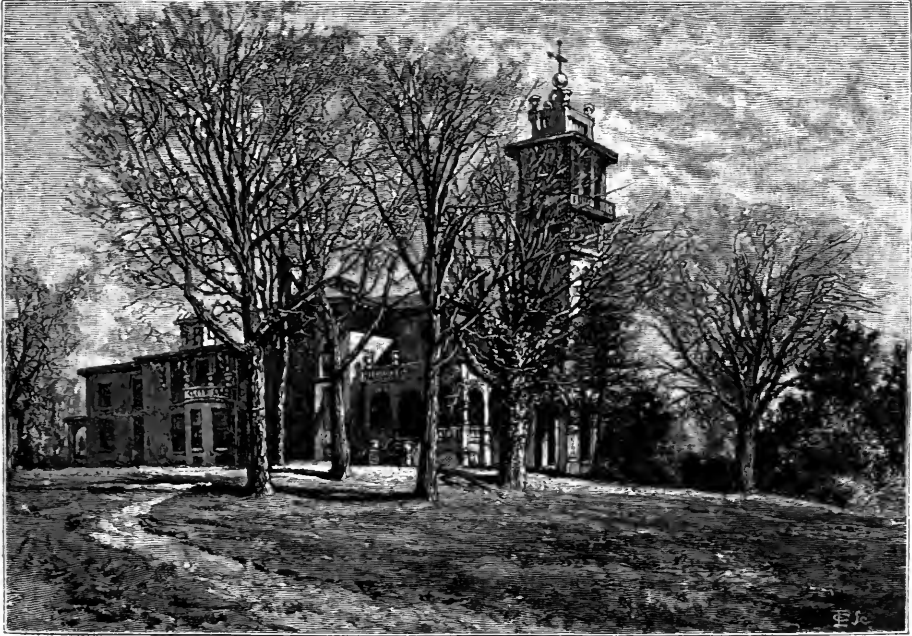

CLIFTON, THE COUNTRY HOME OF THE LATE JOHNS HOPKINS.

have secured the hearty co-operation of all existing powers and institutions in Baltimore, both civil and educational.

A careful investigation led the trustees to believe that there was a growing demand for opportunities to study beyond the ordinary courses of a college or a scientific school, particularly in those branches of learning not included in the schools of law, medicine and theology. Strong evidence of this demand was afforded by the increasing attendance of American students upon the lectures of the German universities, as well as by the number of students who were enrolling themselves at Harvard and Yale for the post-graduate courses.

It was therefore determined that the Johns Hopkins should be primarily a *university*, with advanced courses of lectures and fully equipped laboratories; that the

life could not be transplanted bodily to American soil, and be for us the best possible system. The attempt has therefore been made to gather from the successes and failures of older institutions, in our own and foreign lands, the elements which shall be best suited to meet the demands of time and place. While the university now performs some of the functions which properly belong to schools of a less advanced character, it is hoped that these will redistribute among themselves the educational work necessary to a thorough preliminary training, and that the university will always be ready to take up the work just where they have laid it down.

The endowment having been made by a Baltimore man, and the new institution placed in his own city, the avowed purpose of the trustees from the beginning has been

to extend the benefits of the University, first to Baltimore* and its immediate vicinity, and afterward to let them spread abroad as far as they would. By the interposition of a collegiate course between the high schools and city college of Baltimore on the one hand, and the Johns Hopkins University on the other, the boys and young men of Baltimore have open to them "a well-considered system of instruction from the primary school to the university." The college instruction is in some respects peculiar; there are no classes which correspond to the freshman, junior, sophomore and senior. Each young man, after his matriculation, is assigned to a member of the faculty, who shall act as his official adviser, counseling him in regard to the studies which he shall undertake and their order, and giving him a constant supervision during the course. The abolition of the traditional class system enables a young man to take the position in each particular study for which his specific advancement in that branch fits him. In the ordinary college course, if a young man happens to be deficient in mathematics, for example, he is either forced to lose any advantage he may possess in Greek or Latin, or else is obliged to take a position in mathematics for which he is unprepared. In the college department of the Johns Hopkins, this disadvantage does not exist; the classifying is specific for each study. The student has also the privilege of pushing forward in any one study as rapidly as he can with advantage; or, on the other hand, in case of illness or of unavoidable interruption, of prolonging the time devoted to the course, so that no part of it shall be omitted. As the studies are elective, it is possible to follow the usual college course if one desires.

Seven different courses of study are indicated, any of which leads to the Baccalaureate degree, thus enabling the student to direct and specialize his work. The same standard of matriculation and the same severity of examinations are maintained in all these courses. A student has the privilege of extending his study beyond the regular class work, and he will be credited with all such private and outside study, if his examiners are satisfied of his thoroughness and accuracy.

* As a matter of fact, the number of associates and fellows from Baltimore and Maryland seem to be proportionately very small. What the cause of this may be, it is scarcely within the province of the present article to inquire; the fact is merely given for what it is worth.

Besides the regular corps of professors, which is still small, numbering only six, there are courses of lectures delivered by non-resident professors, as follows:

NON-RESIDENT LECTURERS.

Appointed.	Courses.
1876. Billings, John S., Medical History, etc.,	One.
1876. Child, Francis J., Early English,	Three.
1876. Cooley, Thomas M., Law,	Two.
1876. Hilgard, Julius E., Geodetic Surveys,	One.
1876. Lowell, Jas. Russell, Romance Literature,	One.
1876. Mallet, John W., Technological Chemistry,	Two.
1876. Newcomb, Simon, Astronomy,	One.
1876. Walker, Francis A., Political Economy,	Two.
1876. Whitney, William D., Comparative Philology,	One.
1877. Allen, William F., History,	One.
1878. James, William, Psychology,	One.
1878. Morris, George S., Philosophy,	Two.
1878. Diman, Jeremiah L., History,	One.
1878. Von Holst, H., History,	One.

LECTURERS FOR THE CURRENT YEAR.

Professor T. M. Cooley, of the University of Michigan, Political Science.
Professor J. L. Diman, of Brown University, History.
Professor W. G. Farlow, of Harvard University, Botany.
Professor H. Von Holst, of the University of Freiburg, History.
Professor G. S. Morris, of the University of Michigan, Ethics.
Professor L. Rabillon, of Baltimore, French Literature.

In addition to the resident and non-resident lecturers, a number of young men distinguished for some peculiar natural gifts or special attainments have been gathered about the university under the title of associates. Though instruction is part of their duty, neither the title of "assistant professor" nor that of "tutor" exactly meets the case. A salary of from \$1,000 to \$2,000 is attached to the position. These young men are teachers, both in lecture-room and laboratory, but they are not only teachers. They are usually free to do some independent work, each in his own department,—mathematics, biology, physics or languages,—and such work as possesses permanent or general value finds its way to the literary and scientific world through various channels, including the publications of the university itself. The regular assistant professors are chosen from the ranks of the associates. In the inception of the plan there was some idea of assigning distinct functions to the university, college and assistant professors; but it was found to be most effective to permit this matter to adjust itself, and at present no rigid distinctions exist. The singular flexibility and adaptability of the whole institution is well illustrated by this point. There is no rigid theory to which the students must be broken in; but, like an organic life, development goes on in response to the demands made upon it, and subordinated to the surrounding conditions. Thus the professors and associates are free from severe routine work, and are

saved the danger of falling into ruts in their modes of thinking and instructing, while the students are free to live an individual life, untrammelled by the restrictions of the class. They are permitted and directed how to grow, not molded, and hammered, and chiseled into form.

In order to secure to the university a corps of well-qualified students, a certain number of fellowships were established, with a salary of \$500 per annum attached. These fellowships are most carefully bestowed, and confer upon the recipient, in addition to its educational advantages, a distinction which has been well earned. Twenty young men, graduates of other colleges, who propose to devote themselves to special work, and who have proved themselves capable of so doing, have been thus gathered about the university.

The training of the students is not confined to hearing lectures, making recitations and writing themes. The attempt is made in each department to balance the lecture system by some other method of training. In physical science, this is easily accomplished by laboratory work. In mathematics, languages, philology, etc., other means have to be employed to escape the "tutorial grind" of the English universities. Special clubs are formed by the students among themselves; societies are organized and conducted by the professors; the main and most effective agency, however, is the *seminary*. This is an idea borrowed from the German universities, but greatly modified. The theses in Germany are written and read in Latin or Greek; at the Johns Hopkins, English is used in the main, with practice at special times in oral Greek and Latin. Professor Gildersleeve has kindly written, for this article, this statement of the method in his school, which will serve to make the idea clear, and a full exposition of the method may be found in a paper by him in the "Princeton Review" for May, 1879, on "University Work in America":

"The first of these seminaries to be set on foot was the Greek seminary, which is a modification of the philological seminary of the German universities, in accordance with the different conditions of American philological study. The object of the Greek seminary is to train the future teacher in the exegesis and criticism of Greek authors, and to guide individual research on all the lines of philological inquiry, grammatical, literary, historical and archæological. To promote this end, it has been thought best to group the studies of the seminary each year about some organic center. In 1877-'78, such a center was found in the Attic orators. In the beginning of the course, the rhetorical writings

of Dionysius of Halicarnassus were studied, especially the treatise, "De Admiranda vi Demosthenis," and the application of his canons of criticism to the chief Attic orators was observed, and an endeavor was made, by a close scrutiny of select private orations of Lysias, Isocrates and Isæus, in comparison with speeches of Demosthenes on similar themes, to develop new *indicia* of form. In 1878-'79, the exercises of the Greek seminary consisted in analysis, exegesis and criticism of selected tracts of Lucian, and in the prosecution of researches into the language of Lucian, and the life of the second century,—such as Lucian's relation to Herodotus; the Ionism of the "Dea Syria" and the "De Astrologia;" the use of the optative in Lucian; Lucian and Diogenes Laertius; traditions as to the oriental origin of Greek philosophy; the worship of the Syrian goddess; Lucian's attitude toward religion; Lucian as a student of art. Some of the more elaborate papers were transferred to the Johns Hopkins Philological Association, which meets once a month for the purpose of discussing themes of philological interest. At every such meeting one major paper is presented and considered, while minor communications, and reviews of books and periodicals give the needful variety to the proceedings. Some of these essays have been printed, and thus the seminary works outward into the wider circle of philological life."

In the direction of physical science, every possible aid is afforded for laboratory work,—the most expensive and complicated apparatus for the trying of experiments and the measurement of forces: microscopes, aquaria, from which material for biological study is gathered, instruments for the measurement of nerve force and the rate of nerve waves. The instruments are sometimes singularly simple, and again, as remarkably intricate. Here, for example, stands an instrument for measuring approximately the amount of blood withdrawn from the body to feed the brain while it is at work. It is the invention of an Italian named Mosso. It consists of a horizontal glass tube, open at one end and communicating at the other by means of a small India rubber tube with an open glass vessel on which rests a float. The float carries an index finger. Into the large tube is thrust the arm of the person to be experimented on; the tube, with the arm in it, is made water tight by an India rubber ring; water is then admitted by a cock at the upper side of the glass tube and poured in until the index finger is horizontal. The owner of the arm then engages in conversation, or occupies himself with a book. As the brain requires more blood when it is working, the arm shrinks, and shrinks in proportion as the mental action increases. A moving strip of paper, upon which the index finger makes its record, shows a wavering line, every depression and elevation of which indicates more or less brain-work.

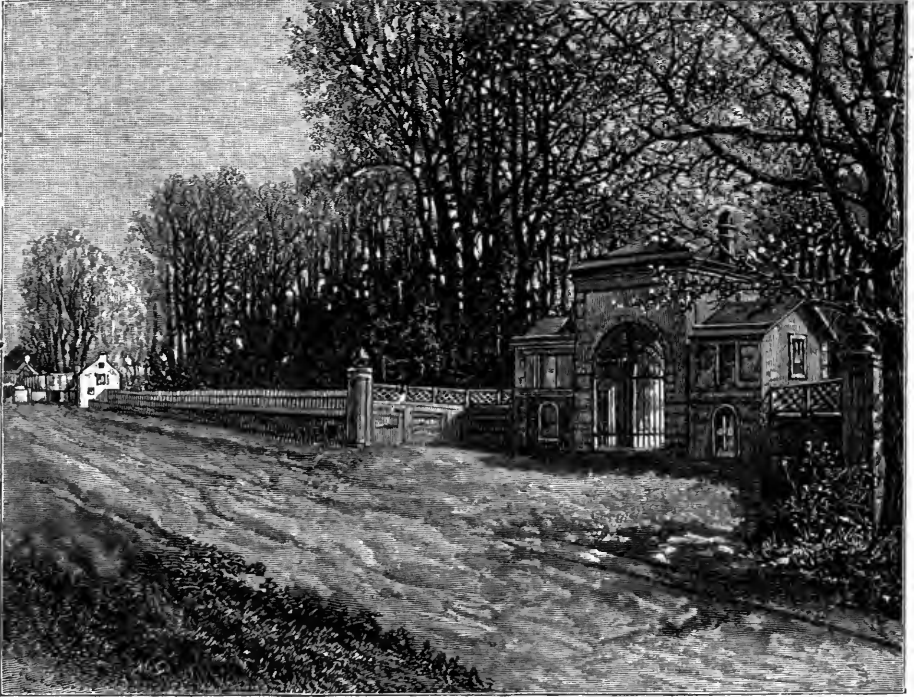

ENTRANCE TO THE GROUNDS OF CLIFTON.

Close by this simple piece of mechanism stands a gigantic and intricate piece of apparatus, which cost \$1,000, with batteries and wires, and all sorts of mechanical devices in bewildering multiplicity. This machine measures the speed of the nervous current. It faithfully records the exact fraction of a second which is required for a message to be sent from a wounded hand, for instance, to head-quarters, and the return command from the brain, to withdraw the injured member from danger. The nerve and muscular action, which seem practically to be simultaneous, and to require no time, are really consecutive, and the time required, though inappreciable, is accurately measurable.

A student, working for several hours each day, in the physical, physiological, or chemical laboratory, working with and without his professors, surrounded by other young men interested in special lines of inquiry, has an exceptional opportunity for individual growth. He has just enough guidance to save him from wandering away into paths that lead nowhere, and not enough to take away his individual responsibility or to cripple his powers of analysis, comparison, discrimination, logical reasoning and practical

judgment. He is stimulated into earnestness and shorn of any disposition to outcropping conceit. His recitation cannot be a parrot-like repetition of a form of words; in fact, it consists rather of an exhibition of accomplished work, which, either in its results or in a careful drawing of them, may be shown to his professor.

These students, it must be remembered, are not boys; they are men, who have chosen their work in life, and are ripe for university freedom. Under such a system it is not to be wondered at that much valuable practical work has been done by the associates and fellows in the various departments. Much has been added in the way of discovery and much in the way of invention. As an illustration of the latter may be mentioned Professor Rowland's apparatus for the determination of the mechanical equivalent of heat. Since the days when Count Rumford, the persistent upholder of the mechanical theory of heat, demonstrated his point by causing water to boil by friction, down to the present time, the determination of the working power of heat has occupied the attention of physicists. It is a question bound up with the central theory of modern physical science, the correlation

and conservation of force. Mr. Rowland has kindly written the following explanation of his valuable invention :

“The object of this investigation was a redetermination of the mechanical equivalent of heat, or the amount of work necessary to heat one pound of water one degree. This quantity was originally determined by Joule with considerable accuracy, but since his time a large number of inaccurate experimenters have so confused it that it became doubtful who was right. Besides, the advance of science has shown that thermometers of different glass differ much from one another, and that they should all be compared with the air thermometer before use. An elaborate series of researches was therefore necessary, the most important of which was made with the instrument shown in Fig. VI. The apparatus for these researches was constructed partly by aid of funds contributed by the American Academy of Sciences in Boston, and partly by the university.”

“In the interior of the calorimeter a paddle wheel is turned rapidly by the shaft, E, which is run by a steam-engine in the next apartment. This paddle-

wheel stirs the water in the calorimeter violently, and makes it strike against some paddles fixed firmly to the calorimeter, and thus tends to turn around also; this force is measured by the weight, P, which it lifts. Knowing this force and the num-



JOHNS HOPKINS.

Fig VI

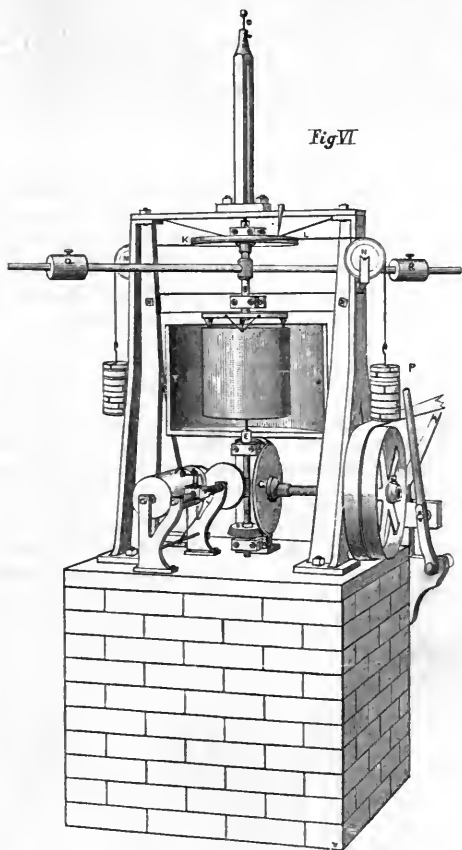

INSTRUMENT FOR DETERMINING THE MECHANICAL EQUIVALENT OF HEAT, INVENTED BY PROF. ROWLAND, OF JOHNS HOPKINS UNIVERSITY.

ber of revolutions made by the shaft, which is recorded on the chronograph seen below, the work can be calculated. By the friction of the water, heat is generated, which is measured by a thermometer not shown. So great is this heat produced, that the water will commence to boil in two hours and a half, merely from the violent stirring.

“The accurate results are about to be published in the proceedings of the American Academy of Sciences at Boston, but the principal results may be stated as follows :

“1st, that the difference of the ordinary and the air thermometer at ordinary temperatures is very appreciable.

“2d, that the specific heat of water *decreases* to about 85° F., after which it *increases*.

“3d, that the mechanical equivalent of heat is as follows :

“From 40° to 41° F.	783.4	foot-pounds.
“ 60° to 61° F.	778.6	“ “
“ 80° to 81° F.	775.7	“ “
“ 100° to 101° F.	776.3	“ “

“The difference from Joule’s result is almost entirely due to Joule having used a mercurial instead of an air thermometer.”

It is not the intention of the trustees of



D. C. GILMAN, PRESIDENT OF THE JOHNS HOPKINS UNIVERSITY.

the Johns Hopkins to collect a large library. The best books of reference, all necessary works of a technical character, are of course at hand; in addition to these, new books are constantly bought and retained till all call for them has passed; they are then disposed of at a small price to professors or students and are removed to give place to others. Without a library no institution can be great; but in Baltimore, the want is supplied by the splendid bequest of George Peabody, and the Peabody Library is not only open to students of the Johns Hopkins University, but a catalogue, including the periodical literature, scientific transactions, etc., of the Peabody, the Historical Society, the Mercantile and the University itself, is printed with initials attached showing where each volume is to be found, and eventually it is hoped to have such a catalogue of all the books in the public institutions of the city as well. By this means much useless labor is, and it is hoped much more will be, spared to the student. By consulting the catalogue he will immediately see whether the University Library contains the material he needs, and if not, whether any of the other libraries of the city does possess it.

The Peabody Library, although possessing only about sixty thousand volumes, is one of the best libraries for students in America. The books have been selected with great judgment, the reading-rooms and alcoves are light and spacious, and every courtesy is offered to students. An experience of six years of almost daily study

in this library unquestionably gives the writer the privilege of testifying.

Not only is this mutual help afforded in the library; the Peabody lecture system, its musical conservatories, and concert seasons, as well as its projected art-galleries, will aid and complement, on the æsthetic side, the more solid advantages of the university. It is also proposed that the Academy of Sciences shall work with the university. Its president, Philip R. Uhler, is an associate of the Johns Hopkins and also the librarian of the Peabody. The medical schools of Baltimore have access to the biological and physiological laboratories, as well as to the lectures of the university. The law classes have also extended to them invitations to attend the lectures of the jurists who have delivered courses in Hopkins Hall. Besides these special invitations, the literary courses are free to the public; a glance at the names of the non-resident lecturers will give some idea of what this really means, as an influence in society.

A great incentive to original research on the part of the associates is offered by the publications of the university. All original work of value finds its way to the public, without having to conquer the difficulties and struggle above the obscurity which so often discourage young and unknown men. This work, under the fostering care and censorship of the university, reaches the outside world indorsed, and at the same time serves to add dignity to the institution itself. The third annual report says:

“Every encouragement has been given to the teachers of the university to publish freely. A list of the various books and papers printed by the resident members of the university during the last two years, under their own names, includes over one hundred titles; among them are many important communications to the scientific journals of this country and of Europe.

“Under the auspices of the university, the ‘American Journal of Mathematics, Pure and Applied,’ has been instituted by Professor Sylvester, with the co-operation of Dr. Story and Professor Rowland of Baltimore, Professor Peirce of Harvard and Professor Newcomb of Washington. The ‘Journal’ appears in large quarto form, whenever sufficient material is presented.

“The researches made in the chemical laboratory under the direction of Professor Remsen and his associate, Dr. Morse, are published in occasional bulletins. Three numbers, including sixty-eight octavo pages, have already appeared.

“Communications from the biological laboratory have been sent to the ‘Journal of Physiology,’ published in Cambridge, England, under the editorial care of Professor Michael Foster, Dr. Martin, of the Johns Hopkins University, being one of the associate editors.

“Philological papers have been submitted to the

American Philological Association and to the American Oriental Society by Professor Gildersleeve, Dr. Lanman, and others."

Since this was published, the "Chemical Notes" have been expanded into the "American Journal of Chemistry," edited by Dr. Remsen; the Biological Papers are now annually collected and published in a volume edited by Dr. Martin; and a prospectus has been published of a philological quarterly, to be edited by Dr. Gildersleeve.

An interesting feature of the University is the summer school of biology. In the summer of 1878, a laboratory was established at Fort Wool, situated in Chesapeake Bay, at the mouth of Hampton Roads. This is an uncompleted fortification, built upon an artificial island with an area of about six acres, a mile and a half from one shore, three miles and a half from the other, and twenty miles from the ocean. Application was made to the government for permission to occupy the large frame buildings on the island for a summer laboratory, and this permission was cordially granted. Twelve microscopes, the necessary chemicals, the books which would be needed from the university and Congressional libraries, as well as a number which were lent, or belonged to the members of the expedition, were taken to the island. The rest of the apparatus,—aquaria dredges, nets, tubs, and buckets,—besides such simple furniture as was indispensable, was purchased by the University, the United States and Maryland Fish Commissions lending boats, a seine, and a dredge. Thus furnished, the party of twelve took possession of the improvised laboratory on the 24th of June, and spent the ensuing eight weeks in investigation.

The work done in such a laboratory is usually considered quite outside the province of a university, but the outlay was comparatively small, and has been far more than justified by results. The school is not unlike, in its scope and intention, the famous Penikese school of Agassiz:

"The laboratory was designed to accomplish four objects: to furnish advanced students with opportunities for original investigation; to provide material for winter work in the university; to enable less advanced students to become acquainted with the many interesting forms of life which can be studied only at the sea-shore, and give them an opportunity to become practically acquainted with the methods of marine zoölogical work; and to increase our scientific acquaintance with the zoölogy of the Chesapeake Bay."

As a result of the summer's session of

1878, a volume of one hundred and fifty pages and fourteen plates has been published. The report for 1879 is not yet published, but from a *résumé* by Dr. Brooks of the summer's work, we extract one fact which seems to illustrate the practical outcome of the work. One of the main investigations for the past summer concerns a subject of wide-reaching interest. Dr. Brooks says:

"The investigations regarding the development of the oyster have led to the important and unexpected conclusion that the breeding habits of the American oysters are so different from those of the oysters of Europe that the methods of artificial oyster propagation which have been carried to such perfection in France and elsewhere must in this country be replaced or supplemented by others. The eggs of the European oyster are fertilized and hatched within the shell of the parent, and are retained there until the young are ready to attach themselves. The most critical period in the life of the young is the time when they are discharged from the parent shell to swim in the water until they find a place to settle down for life. The adult oysters are accordingly placed, at the breeding season, in inlets or basins, among tiles which are prepared to furnish a surface for the attachment of the young as soon as they escape from the shell of the parent.

"The eggs of the American oyster are discharged into the water before they are fertilized, and as fertilization in the open sea is a matter of chance, this is the period of greatest mortality. The experiments of the last summer have shown that the eggs can be artificially fertilized in the laboratory, in a small quantity of water, and the greatest danger to the young can thus be escaped. Since the young American oyster swims at large in the open sea during the time which the oysters of Europe pass inside the shell of the mother, the tile system of culture would seem to be impracticable, for the tides and currents might carry the young twenty miles or more from the tiles before they were old enough to attach themselves. The proper method in this country seems to be the placing of great numbers of artificially fertilized eggs in those waters which are shown by the presence of natural oyster tanks to be favorable to the growth of the animals. While the French method may be pursued to the advantage of the cultivator, and may therefore be left to individual enterprise, the proposed method would be for the benefit of the whole community, and seems to be a proper field for action by the state."

The Johns Hopkins is seeking not only to perfect itself, but to penetrate downward into the preparatory schools, and to bring into harmony with its system even the public schools of the city. In order to do this effectually, courses of laboratory and special instruction have been given to classes of teachers, who thus have open to them courses of instruction which can be had nowhere else in the United States on any terms; for the physiological laboratory of the Johns Hopkins has no peer in this country,



THE TEACHERS' CLASS IN BIOLOGY.

and the other laboratories few equals and no superiors. Thus the teachers are gradually being taught, and the schools are gradually becoming feeders to the University.

There is one other practical feature of the University which may be better illustrated than explained. Besides being a center of instruction and a corporation for independent research, the University endeavors to reach out laterally, to permeate society with its influence. Lectures are delivered by some of the most distinguished scientists and scholars of the country, as well as by the professors and associates. For the benefit of the students and other attendants at these lectures, a list of the bibliography of the subject is frequently printed. The student may thus study up the literature of the subject, consult authorities, follow parallel courses, without wasting time searching for material. In the distribution of the free tickets to these lectures, the claims of teachers always take precedence. In addition to the literary lectures, there are others of a more practical character to which persons specially interested are invited. Such a course was delivered in 1878, on the waste products of various trades, and the processes used, and the possible utilization of such waste material was discussed. All that chemistry knows upon the subject was here collected and presented. To these lectures the principal

tradesmen in Baltimore engaged in chemical industries were invited.

When the hospital buildings are completed and the institution in working order, all possible mutual aid between the university and the hospital will be interchanged. It is impossible to determine, now, just how much will be possible. Meanwhile, with two such endowments as those of Peabody and Hopkins, Baltimore is exceptionally favored.



MEMORIAL TABLET IN HOPKINS HALL.

CONFIDENCE.

BY HENRY JAMES, JR.,

Author of "The American," "The Europeans," "Daisy Miller," Etc.

CHAPTER IX.

BERNARD'S love filled him with a kind of awe, and the feeling was by no means agreeable. It was not a feeling to which even a man of Bernard Longueville's easy power of extracting the savor from a sensation could rapidly habituate himself, and for the rest of that night it was far from making of our hero the happy man that a lover just coming to self-consciousness is supposed to be. It was wrong—it was dishonorable—it was impossible—and yet it *was*; it was, as nothing in his own personal experience had ever been. He seemed hitherto to have been living by proxy, in a vision, an hypothesis—to have been an echo, a shadow, a futile attempt; but this at last was life itself, this was a fact, this was reality. For these things one lived; these were the things that people had died for. Love had been a fable before this—doubtless a very pretty one, and passion had been a literary phrase—employed obviously with considerable effect. But now he stood in a personal relation to these familiar ideas, which gave them a very much keener import; they had laid their hand upon him in the darkness, he felt it upon his shoulder, and he knew by its pressure that it was the hand of destiny. What made this sensation a shock was the element that was mixed with it; the fact that it came not simply and singly, but with an attendant shadow in which it immediately merged and lost itself. It was forbidden fruit—he knew it the instant he had touched it. He felt that he had pledged himself *not* to do just this thing which was gleaming before him so divinely—not to widen the crevice, not to open the door that would flood him with light. Friendship and honor were at stake; they stood at his left hand, as his new-born passion stood already at his right; they claimed him as well, and their grasp had a pressure which might become acutely painful. The soul is a still more tender organism than the body, and it shrinks from the prospect of being subjected to violence. Violence—spiritual violence—was what our luxurious hero feared; and it is not too much to say that as he lingered there by the sea, late into the night, while the gurgitation of the

waves grew deeper to his ear, the prospect came to have an element of positive terror. The two faces of his situation stood confronting each other; it was a rigid, brutal opposition, and Bernard held his breath for a while with the wonder of what would come of it. He sat a long time upon the beach; the night grew very cold, but he had no sense of it. Then he went away and passed before the Casino again, and wandered through the village. The Casino was shrouded in darkness and silence, and there was nothing in the streets of the little town but the salt smell of the sea, a vague aroma of fish and the distant sound of the breakers. Little by little, Bernard lost the feeling of having been startled, and began to perceive that he could reason about his trouble. Trouble it was, though this seems an odd name for the consciousness of a bright enchantment; and the first thing that reason, definitely consulted, told him about the matter was that he had been in love with Angela Vivian any time these three years. This sapient faculty supplied him with further information; only two or three of the items of which, however, it is necessary to reproduce. He had been a great fool—an incredible fool—not to have discovered before this what was the matter with him. Bernard's sense of his own shrewdness—always tolerably acute—had never received such a bruise as this present perception that a great many things had been taking place in his clever mind without his clever mind suspecting them. But it little mattered, his reason went on to declare, what he had suspected or what he might now feel about it; his present business was to leave Blanquis-les-Galets at sunrise the next morning and never rest his eyes upon Angela Vivian again. This was his duty; it had the merit of being perfectly plain and definite, easily apprehended, and unattended, as far as he could discover, with the smallest material difficulties. Not only this, reason continued to remark; but the moral difficulties were equally inconsiderable. He had never breathed a word of his passion to Miss Vivian—quite the contrary; he had never committed himself nor given her the smallest reason to suspect his hidden flame; and he

was therefore perfectly free to turn his back upon her—he could never incur the reproach of trifling with her affections. Bernard was in that state of mind when it is the greatest of blessings to be saved the distress of choice—to see a straight path before you and to feel that you have only to follow it. Upon the straight path I have indicated, he fixed his eyes very hard; of course he would take his departure at the earliest possible hour on the morrow. There was a streak of morning in the eastern sky by the time he knocked for re-admittance at the door of the inn, which was opened to him by a mysterious old woman in a night-cap and scanty accessories, whose identity he failed to ascertain; and he laid himself down to rest—he was very tired—with his eyes fixed, as I say, on the idea—on the very image—of departure.

On waking up the next morning, rather late, he found, however, that they had attached themselves to a very different object. His vision was filled with the brightness of the delightful fact itself, which seemed to impregnate the sweet morning air and to flutter in the light, fresh breeze that came through his open window from the sea. He saw a great patch of the sea between a couple of red-tiled roofs; it was bluer than any sea had ever been before. He had not slept long—only three or four hours; but he had quite slept off his dread. The shadow had dropped away and nothing was left but the beauty of his love, which seemed to shine in the freshness of the early day. He felt absurdly happy—as if he had discovered El Dorado; quite apart from consequences—he was not thinking of consequences, which of course were another affair—the feeling was intrinsically the finest one he had ever had, and—as a mere feeling—he had not done with it yet. The consideration of consequences could easily be deferred, and there would, meanwhile, be no injury to any one in his extracting, very quietly, a little subjective joy from the state of his heart. He would let the flower bloom for a day before plucking it up by the roots. Upon this latter course he was perfectly resolved, and in view of such an heroic resolution the subjective interlude appeared no more than his just privilege. The project of leaving Blanquais-les-Galets at nine o'clock in the morning dropped lightly from his mind, making no noise as it fell; but another took its place, which had an air of being still more excellent and which consisted of starting off on a long walk and

absenting himself for the day. Bernard grasped his stick and wandered away; he climbed the great shoulder of the further cliff and found himself on the level downs. Here there was apparently no obstacle whatever to his walking as far as his fancy should carry him. The summer was still in a splendid mood, and the hot and quiet day—it was a Sunday—seemed to constitute a deep, silent smile on the face of nature. The sea glistened on one side, and the crops ripened on the other; the larks, losing themselves in the dense sunshine, made it ring here and there in undiscoverable spots; this was the only sound save when Bernard, pausing now and then in his walk, found himself hearing far below him, at the base of the cliff, the drawing murmur of a wave. He walked a great many miles and passed through half a dozen of those rude fishing-hamlets, lodged in some sloping hollow of the cliffs, so many of which, of late years, all along the Norman coast, have adorned themselves with a couple of hotels and a row of bathing-machines. He walked so far that the shadows had begun to lengthen before he bethought himself of stopping; the afternoon had come on and had already begun to wane. The grassy downs still stretched before him, shaded here and there with shallow but windless dells. He looked for the softest place and then flung himself down on the grass; he lay there for a long time, thinking of many things. He had determined to give himself up to a day's happiness; it was happiness of a very harmless kind—the satisfaction of thought, the bliss of mere consciousness; but such as it was it did not elude him nor turn bitter in his heart, and the long summer day closed upon him before his spirit, hovering in perpetual circles round the idea of what *might* be had, began to rest its wing. When he rose to his feet again it was too late to return to Blanquais in the same way that he had come; the evening was at hand, the light was already fading, and the walk he had taken was one which even if he had not felt very tired, he would have thought it imprudent to attempt to repeat in the darkness. He made his way to the nearest village, where he was able to hire a rustic *carriole*, in which primitive conveyance, gaining the high-road, he joggled and jostled through the hours of the evening slowly back to his starting-point. It wanted an hour of midnight by the time he reached his inn, and there was nothing left for him but to go to bed.

He went in the unshaken faith that he should leave Blanquais early on the morrow. But early on the morrow it occurred to him that it would be simply grotesque to go off without taking leave of Mrs. Vivian and her daughter, and offering them some explanation of his intention. He had given them to understand that, so delighted was he to find them there, he should remain at Blanquais at least as long as they. He must have seemed to them wanting in civility, to spend a whole bright Sunday without apparently troubling his head about them, and if the unlucky fact of his being in love with the girl were a reason for doing his duty, it was at least not a reason for being rude. He had not yet come to that—to accepting rudeness as an incident of virtue; it had always been his theory that virtue had the best manners in the world, and he flattered himself at any rate that he could guard his own integrity without making himself ridiculous. So, at what he thought a proper hour, in the course of the morning, he retraced his steps along the little lane through which, two days ago, Angela Vivian had shown him the way to her mother's door. At this humble portal he knocked; the windows of the little *châlet* were open, and the white curtains, behind the flower-pots, were fluttering as he had seen them before. The door was opened by a neat young woman, who informed him very promptly that Madame and Mademoiselle had left Blanquais a couple of hours earlier. They had gone to Paris—yes, very suddenly, taking with them but little luggage, and they had left her—she had the honor of being the *femme de chambre* of *ces dames*—to put up their remaining possessions and follow as soon as possible. On Bernard's expressing surprise and saying that he had supposed them to be fixed at the sea-side for the rest of the season, the *femme de chambre*, who seemed a very intelligent person, begged to remind him that the season was drawing to a close, that Madame had taken the *châlet* but for five weeks, only ten days of which period were yet to expire, that *ces dames*, as Monsieur perhaps knew, were great travelers, who had been half over the world and thought nothing of breaking camp at an hour's notice, and that, in fine, Madame might very well have received a telegram summoning her to another part of the country.

"And where have the ladies gone?" asked Bernard.

"For the moment, to Paris."

"And in Paris where have they gone?"

"*Dame, chez elles*—to their house," said the *femme de chambre*, who appeared to think that Bernard asked too many questions.

But Bernard persisted.

"Where is their house?"

The discreet soubrette looked at him from head to foot.

"If Monsieur wishes to write, many of Madame's letters come to her banker," she said, inscrutably.

"And who is her banker?"

"He lives in the Rue de Provence."

"Very good—I will find him out," said our hero, turning away.

The discriminating reader who has been so good as to interest himself in this little narrative will perhaps at this point exclaim with a pardonable consciousness of shrewdness: "Of course he went the next day to the Rue de Provence!" Of course, yes; only as it happens Bernard did nothing of the kind. He did one of the most singular things he ever did in his life—a thing that puzzled him even at the time and with regard to which he often afterward wondered whence he had drawn the ability for so remarkable a feat—he simply spent a fortnight at Blanquais-les-Galets. It was a very quiet fortnight; he spoke to no one, he formed no relations, he was company to himself. It may be added that he had never found his own company half so good. He struck himself as a reasonable, delicate fellow, who looked at things in such a way as to make him refrain—refrain successfully, that was the point—from concerning himself practically about Angela Vivian. His saying that he would find out the banker in the Rue de Provence had been for the benefit of the *femme de chambre*, whom he thought rather impertinent; he had really no intention whatever of entering that classic thoroughfare. He took long walks, rambled on the beach, along the base of the cliffs and among the brown sea-caves, and he thought a good deal of certain incidents which have figured at an earlier stage of this narrative. He had forbidden himself the future, as an object of contemplation, and it was therefore a matter of necessity that his imagination should take refuge among the warm and familiar episodes of the past. He wondered why Mrs. Vivian should have left the place so suddenly, and was of course struck with the analogy between this incident and her abrupt departure from Baden. It annoyed him, it troubled him, but it by no

means rekindled the alarm he had felt on first perceiving the injured Angela on the beach. That alarm had been quenched by Angela's manner during the hour that followed and during their short talk in the evening. This evening was to be forever memorable, for it had brought with it the revelation which still, at moments, suddenly made Bernard tremble; but it had also brought him the assurance that Angela cared as little as possible for anything that a chance acquaintance might have said about her. It is all the more singular, therefore, that one evening, after he had been at Blanquais a fortnight, a train of thought should suddenly have been set in motion in his mind. It was kindled by no outward occurrence, but by some wandering spark of fancy or of memory, and the immediate effect of it was to startle our hero very much as he had been startled on the evening I have described. The circumstances were the same; he had wandered down to the beach alone, very late, and he stood looking at the duskily tumbling sea. Suddenly the same voice that had spoken before murmured another phrase in the darkness, and it rang upon his ear for the rest of the night. It startled him, as I have said, at first; then, the next morning, it led him to take his departure for Paris. During the journey it lingered in his ear; he sat in the corner of the railway-carriage with his eyes closed, abstracted, on purpose to prolong the reverberation. If it were not true it was at least, as the Italians have it, *ben trovato*, and it was wonderful how well it bore thinking of. It bears telling less well; but I can at least give a hint of it. The theory that Angela hated him had evaporated in her presence, and another of a very different sort had sprung into being. It fitted a great many of the facts, it explained a great many contradictions, anomalies, mysteries, and it accounted for Miss Vivian's insisting upon her mother's leaving Blanquais at a few hours' notice, even better than the theory of her resentment could have done. At any rate, it obliterated Bernard's scruples very effectually, and led him on his arrival in Paris to repair instantly to the Rue de Provence. This street contains more than one banker, but there is one with whom Bernard deemed Mrs. Vivian most likely to have dealings. He found he had reckoned rightly, and he had no difficulty in procuring her address. Having done so, however, he by no means went immediately to see her; he waited a couple of days—perhaps to

give those obliterated scruples I have spoken of a chance to revive. They kept very quiet, and it must be confessed that Bernard took no great pains to recall them to life. After he had been in Paris three days, he knocked at Mrs. Vivian's door.

It was opened by the little waiting-maid whom he had seen at Blanquais, and who looked at him very hard before she answered his inquiry.

"You see I have found Mrs. Vivian's dwelling, though you wouldn't give me the address," Bernard said to her, smiling.

"Monsieur has put some time to it!" the young woman answered dryly. And she informed him that Madame was at home, though Mademoiselle, for whom he had not asked, was not.

Mrs. Vivian occupied a diminutive apartment at the summit of one of the tall white houses which ornament the neighborhood of the Arc de Triomphe. The early days of September had arrived, but Paris was still a city of absentees. The weather was warm and charming, and a certain savor of early autumn in the air was in accord with the somewhat melancholy aspect of the empty streets and closed shutters of this honorable quarter, where the end of the monumental vistas seemed to be curtailed with a hazy emanation from the Seine. It was late in the afternoon when Bernard was ushered into Mrs. Vivian's little high-nestling drawing-room, and a patch of sunset tints, faintly red, rested softly upon the gilded wall. Bernard had seen these ladies only in borrowed and provisional abodes; but here was a place where they were really living and which was stamped with their tastes, their habits, their charm. The little *salon* was very charming; it contained a multitude of pretty things, and it appeared to Bernard to be arranged in perfection. The long windows—the ceiling being low, they were really very short—opened upon one of those solid balconies, occupying the width of the apartment, which are often in Paris a compensation for living up five flights of stairs, and this balcony was filled with flowers and cushions. Bernard stepped out upon it to await the coming of Mrs. Vivian, and, as she was not quick to appear, he had time to see that his friends enjoyed a magnificent view. They looked up at the triumphal Arch, which presented itself at a picturesque angle, and near the green tree-tops of the Champs Elysées, beyond which they caught a broad gleam of the Seine and a glimpse, blue in the distance, of the great

towers of Nôtre Dame. The whole vast city lay before them and beneath them, with its ordered brilliancy and its mingled aspect of compression and expansion; and yet the huge Parisian murmur died away before it reached Mrs. Vivian's sky-parlor, which seemed to Bernard the brightest and quietest little habitation he had ever known.

His hostess came rustling in at last; she seemed agitated; she knocked over with the skirt of her dress a little gilded chair which was reflected in the polished *parquet* as in a sheet of looking-glass. Mrs. Vivian had a fixed smile—she hardly knew what to say.

"I found your address at the banker's," said Bernard. "Your maid, at Blanquais, refused to give it to me."

Mrs. Vivian gave him a little look—there was always more or less of it in her face—which seemed equivalent to an entreaty that her interlocutor should spare her.

"Maids are so strange," she murmured; "especially the French!"

It pleased Bernard for the moment not to spare her, though he felt a sort of delight of kindness for her.

"Your going off from Blanquais so suddenly, without leaving me any explanation, any clue, any message of any sort—made me feel at first as if you didn't wish that I should look you up. It reminded me of the way you left Baden—do you remember?—three years ago."

"Baden was so charming—but one couldn't stay forever," said Mrs. Vivian.

"I had a sort of theory one could. Our life was so pleasant that it seemed a shame to break the spell, and if no one had moved I am sure we might be sitting there now."

Mrs. Vivian stared, still with her little fixed smile.

"I think we should have had had bad weather."

"Very likely," said Bernard, laughing. "Nature would have grown jealous of our good-humor—of our charming happiness. And after all, here we are together again—that is, some of us. But I have only my own audacity to thank for it. I was quite free to believe that you were not at all pleased to see me re-appear—and it is only because I am not easy to discourage—am indeed probably a rather impudent fellow—that I have ventured to come here to-day."

"I am very glad to see you re-appear, Mr. Longueville," Mrs. Vivian declared with the accent of veracity.

"It was your daughter's idea, then, running away from Blanquais?"

Mrs. Vivian lowered her eyes.

"We were obliged to go to Fontainebleau. We have but just come back. I thought of writing to you," she softly added.

"Ah, what pleasure that would have given me!"

"I mean, to tell you where we were, and that we should have been so happy to see you."

"I thank you for the intention. I suppose your daughter wouldn't let you carry it out."

"Angela is so peculiar," Mrs. Vivian said, simply.

"You told me that the first time I saw you."

"Yes, at Siena," said Mrs. Vivian.

"I am glad to hear you speak frankly of that place!"

"Perhaps it's better," Mrs. Vivian murmured. She got up and went to the window; then stepping upon the balcony, she looked down a moment into the street. "She will come back in a moment," she said, coming into the room again. "She has gone to see a friend who lives just beside us. We don't mind about Siena now," she added, softly.

Bernard understood her—understood this to be a retraction of the request she had made of him at Baden.

"Dear little woman," he said to himself, "she wants to marry her daughter still—only now she wants to marry her to me!"

He wished to show her that he understood her, and he was on the point of seizing her hand, to do he didn't know what—to hold it, to press it, to kiss it—when he heard the sharp twang of the bell at the door of the little apartment.

Mrs. Vivian fluttered away.

"It's Angela!" she cried, and she stood there waiting and listening, smiling at Bernard, with her handkerchief pressed to her lips.

In a moment the girl came into the drawing-room, but on seeing Bernard she stopped, with her hand on the door-knob. Her mother went to her and kissed her.

"It's Mr. Longueville, dearest—he has found us out."

"Found us out!" repeated Angela, with a little laugh. "What a singular expression!"

She was blushing as she had blushed when she first saw him at Blanquais. She seemed to Bernard now to have a great and

peculiar brightness—something she had never had before.

"I certainly have been looking for you," he said. "I was greatly disappointed when I found you had taken flight from Blanquais."

"Taken flight?" She repeated his words as she had repeated her mother's. "That is also a strange way of speaking!"

"I don't care what I say," said Bernard, "so long as I make you understand that I have wanted very much to see you again, and that I have wondered every day whether I might venture——"

"I don't know why you shouldn't venture!" she interrupted, giving her little laugh again. "We are not so terrible, are we, mamma?—that is, when once you have climbed our five flights of stairs."

"I came up very fast," said Bernard, "and I find your apartment charming."

"Mr. Longueville must come again, must he not, dear?" asked mamma.

"I shall come very often, with your leave," Bernard declared.

"It will be immensely kind," said Angela, looking away.

"I am not sure that you will think it that."

"I don't know what you are trying to prove," said Angela; "first that we ran away from you, and then that we are not nice to our visitors."

"Oh no, not that!" Bernard exclaimed; "for I assure you I shall not care how cold you are with me."

She walked away toward another door, which was masked with a curtain that she lifted.

"I am glad to hear that, for it gives me courage to say that I am very tired, and that I beg you will excuse me."

She glanced at him a moment over her shoulder; then she passed out, dropping the curtain.

Bernard stood there face to face with Mrs. Vivian, whose eyes seemed to plead with him more than ever. In his own there was an excited smile.

"Please don't mind that," she murmured. "I know it's true that she is tired."

"Mind it, dear lady?" cried the young man. "I delight in it. It's just what I like."

"Ah, she's very peculiar!" sighed Mrs. Vivian.

"She is strange—yes. But I think I understand her a little."

"You must come back to-morrow, then."

"I hope to have many to-morrows!" cried Bernard as he took his departure.

And he had them in fact. He called the next day at the same hour, and he found the mother and the daughter together in their pretty *salon*. Angela was very gentle and gracious; he suspected Mrs. Vivian had given her a tender little lecture upon the manner in which she had received him the day before. After he had been there five minutes, Mrs. Vivian took a decanter of water that was standing upon a table and went out on the balcony to irrigate her flowers. Bernard watched her a while from his place in the room; then she moved along the balcony and out of sight. Some ten minutes elapsed without her re-appearing, and then Bernard stepped to the threshold of the window and looked for her. She was not there, and as he came and took his seat near Angela again, he announced, rather formally, that Mrs. Vivian had passed back into one of the other windows.

Angela was silent a moment—then she said,—

"Should you like me to call her?"

She *was* very peculiar—that was very true; yet Bernard held to his declaration of the day before that he now understood her a little.

"No, I don't desire it," he said. "I wish to see you alone; I have something particular to say to you."

She turned her face toward him, and there was something in its expression that showed him that he looked to her more serious than he had ever looked. He sat down again; for some moments he hesitated to go on.

"You frighten me," she said laughing; and in spite of her laugh this was obviously true.

"I assure you my state of mind is anything but formidable. I am afraid of *you*, on the contrary; I am humble and apologetic."

"I am sorry for that," said Angela. "I particularly dislike receiving apologies, even when I know what they are for. What yours is for, I can't imagine."

"You don't dislike me—you don't hate me?" Bernard suddenly broke out.

"You don't ask me that humbly. Excuse me therefore if I say I have other, and more practical, things to do."

"You despise me," said Bernard.

"That's not humble either, for you seem to insist upon it."

"It would be after all a way of thinking

of me, and I have a reason for wishing you to do that."

"I remember very well that you used to have a reason for everything. It was not always a good one."

"This one is excellent," said Bernard, gravely. "I have been in love with you for three years."

She got up slowly, turning away.

"Is that what you wished to say to me?"

She went toward the open window, and he followed her.

"I hope it doesn't offend you. I don't say it lightly—it's not a piece of gallantry. It's the very truth of my being. I didn't know it till lately—strange as that may seem. I loved you long before I knew it—before I ventured or presumed to know it. I was thinking of you when I seemed to myself to be thinking of other things. It is very strange—there are things in it I don't understand. I traveled over the world, I tried to interest, to divert myself; but at bottom it was a perfect failure. To see you again—that was what I wanted. When I saw you last month at Blanquais I knew it; then everything became clear. It was the answer to the riddle. I wished to read it very clearly—I wished to be sure; therefore I didn't follow you immediately. I questioned my heart—I cross-questioned it. It has borne the examination, and now I am sure. I am very sure. I love you as my life—I beg you, listen to me!"

She had listened—she had listened intently, looking straight out of the window and without moving.

"You have seen very little of me," she said, presently, turning her illuminated eye on him.

"I have seen enough," Bernard added, smiling. "You must remember that at Baden I saw a good deal of you."

"Yes, but that didn't make you like me. I don't understand."

Bernard stood there a moment, frowning, with his eyes lowered.

"I can imagine that. But I think I can explain."

"Don't explain now," said Angela. "You have said enough; explain some other time." And she went out on the balcony.

Bernard, of course, in a moment was beside her, and, disregarding her injunction, he began to explain.

"I thought I disliked you—but I have come to the conclusion it was just the contrary. In reality I was in love with you.

I had been so from the first time I saw you—when I made that sketch of you at Siena."

"That in itself needs an explanation. I was not at all nice then—I was very rude, very perverse. I was horrid!"

"Ah, you admit it!" cried Bernard, with a sort of quick elation.

She had been pale, but she suddenly blushed.

"Your own conduct was singular, as I remember it. It was not exactly agreeable."

"Perhaps not; but at least it was meant to be. I didn't know how to please you then, and I am far from supposing that I have learned now. But I entreat you to give me a chance."

She was silent a while; her eyes wandered over the great prospect of Paris.

"Do you know how you can please me now?" she said, at last. "By leaving me alone."

Bernard looked at her a moment, then came straight back into the drawing-room and took his hat.

"You see I avail myself of the first chance. But I shall come back to-morrow."

"I am greatly obliged to you for what you have said. Such a speech as that deserves to be listened to with respect—and to be thought of with kindness. You may come back to-morrow," Angela added.

On the morrow, when he came back, she received him alone.

"How did you know, at Baden, that I didn't like you?" he asked, as soon as she would allow him.

She smiled, very gently.

"You assured me yesterday that you did like me."

"I mean that I supposed I didn't. How did you know that?"

"I can only say that I observed."

"You must have observed very closely, for, superficially, I rather had the air of admiring you," said Bernard.

"It was very superficial."

"You don't mean that; for, after all, that is just what my admiration, my interest in you, were not. They were deep, they were latent. They were not superficial—they were subterranean."

"You are contradicting yourself, and I am perfectly consistent," said Angela. "Your sentiments were so well hidden that I supposed I displeased you."

"I remember that at Baden, you used to contradict yourself," Bernard answered.

"You have a terrible memory!"

"Don't call it terrible, for it sees every-

thing now in a charming light—in the light of this understanding that we have at last arrived at, which seems to shine backward—to shine full on those Baden days.”

“Have we at last arrived at an understanding?” she asked, with a grave directness which Bernard thought the most beautiful thing he had ever seen.

“It only depends upon you,” he declared; and then he broke out again into a protestation of passionate tenderness. “Don’t put me off this time,” he cried. “You have had time to think about it; you have had time to get over the surprise, the shock. I love you, and I offer you everything that belongs to me in this world.” As she looked at him with her dark, clear eyes, weighing this precious vow and yet not committing herself—“Ah, you don’t forgive me!” he murmured.

She gazed at him with the same solemn brightness.

“What have I to forgive you?”

This question seemed to him enchanting. He reached forward and took her hands, and if Mrs. Vivian had come in she would have seen him kneeling at her daughter’s feet.

But Mrs. Vivian remained in seclusion, and Bernard saw her only the next time he came.

“I am very happy, because I think my daughter is happy,” she said.

“And what do you think of me?”

“I think you are very clever. You must promise me to be very good to her.”

“I am clever enough to promise that.”

“I think you are good enough to keep it,” said Mrs. Vivian. She looked as happy as she said, and her happiness gave her a communicative, confidential tendency. “It is very strange how things come about—how the wheel turns round,” she went on. “I suppose there is no harm in my telling you that I believe she always cared for you.”

“Why didn’t you tell me before?” said Bernard, with almost filial reproachfulness.

“How could I? I don’t go about the world offering my daughter to people—especially to indifferent people.”

“At Baden you didn’t think I was indifferent. You were afraid of my not being indifferent enough.”

Mrs. Vivian colored.

“Ah, at Baden I was a little too anxious!”

“Too anxious I shouldn’t speak to your daughter!” said Bernard, laughing.

“At Baden,” Mrs. Vivian went on, “I

had views. But I haven’t any now—I have given them up.”

“That makes your acceptance of me very flattering!” Bernard exclaimed, laughing still more gayly.

“I have something better,” said Mrs. Vivian, laying her finger-tips on his arm. “I have confidence.”

Bernard did his best to encourage this gracious sentiment, and it seemed to him that there was something yet to be done to implant it more firmly in Angela’s breast.

“I have a confession to make to you,” he said to her one day. “I wish you would listen to it.”

“Is it something very horrible?” Angela asked.

“Something very horrible indeed. I once did you an injury.”

“An injury?” she repeated, in a tone which seemed to reduce the offense to contemptible proportions by simple vagueness of mind about it.

“I don’t know what to call it,” said Bernard. “A poor service—an ill-turn.”

Angela gave a shrug, or rather an imitation of a shrug, for she was not a shrugging person.

“I never knew it.”

“I misrepresented you to Gordon Wright,” Bernard went on.

“Why do you speak to me of him?” she asked rather sadly.

“Does it displease you?”

She hesitated a little.

“Yes, it displeases me. If your confession has anything to do with him, I would rather not hear it.”

Bernard returned to the subject another time—he had plenty of opportunities. He spent a portion of every day in the company of his amiable compatriots. And these days were the happiest of his life. The autumn weather was warm and soothing, the *quartier* was still deserted, and the uproar of the great city, which seemed a hundred miles away, reached them through the dense October air with a softened and muffled sound. The evenings, however, were growing cool, and before long they lighted the first fire of the season in Mrs. Vivian’s heavily draped little chimney-piece. On this occasion Bernard sat there with Angela, watching the bright crackle of the wood and feeling that the charm of winter nights had begun. These two young people were alone together in the gathering dusk; it was the hour before dinner, before the lamp had been lighted.

"I insist upon making you my confession," said Bernard. "I shall be very unhappy until you let me do it."

"Unhappy? You are the happiest of men."

"I lie upon roses, if you will; but this memory, this remorse, is a folded rose-leaf. I was completely mistaken about you at Baden; I thought all manner of evil of you—or at least I said it."

"Men are dull creatures," said Angela.

"I think they are. So much so that, as I look back upon that time, there are some things I don't understand even now."

"I don't see why you should look back. People in our position are supposed to look forward."

"You don't like those Baden days yourself," said Bernard. "You don't like to think of them."

"What a wonderful discovery!"

Bernard looked at her a moment in the brightening fire-light.

"What part was it you tried to play there?"

Angela shook her head.

"Men are dull creatures."

"I have already granted that, and I am eating humble pie in asking for an explanation."

"What did you say of me?" Angela asked, after a silence.

"I said you were a coquette. Remember that I am simply historical."

She got up and stood in front of the fire, having her hand on the chimney-piece and looking down at the blaze. For some moments she remained there. Bernard could not see her face.

"I said you were a dangerous woman to marry," he went on deliberately. "I said it because I thought it. I gave Gordon an opinion about you—it was a very unfavorable one. I couldn't make you out—I thought you were playing a double part. I believed that you were ready to marry him, and yet I saw—I thought I saw——" and Bernard paused again.

"What did you see?" and Angela turned toward him.

"That you were encouraging me—playing with me."

"And you didn't like that?"

"I liked it immensely—for myself! But didn't like it for Gordon; and I must do myself the justice to say that I thought more of him than of myself."

"You were an excellent friend," said Angela, simply.

"I believe I was. And I am still," Bernard added.

She shook her head sadly.

"Poor Mr. Wright!"

"He is a dear good fellow," said Bernard.

"Thoroughly good, and dear, doubtless to his wife, the affectionate Blanche."

"You don't like him—you don't like her," said Bernard.

"Those are two very different matters. I am very sorry for Mr. Wright."

"You needn't be that. He is doing very well."

"So you have already informed me. But I am sorry for him, all the same."

"That doesn't answer my question," Bernard exclaimed, with a certain irritation.

"What part were you playing?"

"What part do you think?"

"Haven't I told you I gave it up, long ago?"

Angela stood with her back to the fire, looking at him; her hands were locked behind her.

"Did it ever strike you that my position at Baden was a charming one?—knowing that I had been handed over to you to be put under the microscope—like an insect with a pin stuck through it!"

"How in the world did you know it? I thought we were particularly careful."

"How can a woman keep knowing such a thing? She guesses it—she discovers it by instinct; especially if she is a proud woman."

"Ah," said Bernard, "if pride is a source of information, you must be a prodigy of knowledge!"

"I don't know that you are particularly humble!" the girl retorted. "The meekest and most submissive of her sex would not have consented to have such a bargain as that made about her—such a trick played upon her!"

"My dearest Angela, it was no bargain—no trick!" Bernard interposed.

"It was a clumsy trick—it was a bad bargain!" she declared. "At any rate I hated it—I hated the idea of your pretending to pass judgment upon me; of your having come to Baden for the purpose. It was as if Mr. Wright had been buying a horse and you had undertaken to put me through my paces!"

"I undertook nothing—I declined to undertake."

"You certainly made a study of me—and I was determined you should get your les-

son wrong. I determined to embarrass, to mislead, to defeat you. Or rather, I didn't determine; I simply obeyed a natural impulse of self-defense—the impulse to evade the fierce light of criticism. I wished to put you in the wrong."

"You did it all very well. You put me admirably in the wrong."

"The only justification for my doing it at all was my doing it well," said Angela.

"You were justified then! You must have hated me fiercely."

She turned her back to him and stood looking at the fire again.

"Yes, there are some things that I did that can be accounted for only by an intense aversion."

She said this so naturally that in spite of a certain theory that was touched upon a few pages back, Bernard was a good deal bewildered. He rose from the sofa where he had been lounging and went and stood beside her a moment. Then he passed his arm round her waist and murmured an almost timorous:

"Really?"

"I don't know what you are trying to make me say!" she answered.

He looked down at her for a moment as he held her close to him.

"I don't see, after all, why I should wish to make you say it. It would only make my remorse more acute."

She was musing, with her eyes on the fire, and for a moment she made no answer; then, as if her attention were returning—

"Are you still talking about your remorse?" she asked.

"You see I put it very strongly."

"That I was a horrid creature?"

"That you were not a woman to marry."

"Ah, my poor Bernard," said Angela, "I can't attempt to prove to you that you are not inconsistent!"

The month of September drew to a close, and she consented to fix a day for their wedding. The last of October was the moment selected, and the selection was almost all that was wanting to Bernard's happiness. I say "almost," for there was a solitary spot in his consciousness which felt numb and dead—unpervaded by the joy with which the rest of his spirit seemed to thrill and tingle. The removal of this hard grain in the sweet savor of life was needed to complete his felicity. Bernard felt that he had made the necessary excision when, at the end of the month, he

wrote to Gordon Wright of his engagement. He had been putting off the performance of this duty from day to day—it seemed so hard to accomplish it gracefully. He did it at the end very briefly; it struck him that this was the best way. Three days after he had sent his letter there arrived one from Gordon himself, informing Bernard that he had suddenly determined to bring Blanche to Europe. She was not well, and they would lose no time. They were to sail within a week after his writing. The letter contained a postscript—"Captain Lovelock comes with us."

CHAPTER X.

BERNARD prepared for Gordon's arrival in Paris, which, according to his letter, would take place in a few days. He was not intending to stop in England; Blanche desired to proceed immediately to the French capital, to confer with her man-miliner, after which it was probable that they would go to Italy or to the East for the winter. "I have given her a choice of Rome or the Nile," said Gordon, "but she tells me she doesn't care a fig where we go."

I say that Bernard prepared to receive his friends, and I mean that he prepared morally—or even intellectually. Materially speaking, he could simply hold himself in readiness to engage an apartment at a hotel and to go to meet them at the station. He expected to hear from Gordon as soon as this interesting trio had arrived in England, but the first notification he received came from a Parisian hotel. It reached him in the shape of a very short note, in the morning, shortly before lunch, and was to the effect that his friends had alighted in the Rue de la Paix the night before.

"We were tired, and I have slept late," said Gordon; "otherwise you should have heard from me earlier. Come to lunch, if possible. I want extremely to see you."

Bernard, of course, made a point of going to lunch. In as short a time as possible he found himself in Gordon's sitting-room at the Hotel Middlesex. The table was laid for the midday repast, and a gentleman stood with his back to the door, looking out of the window. As Bernard came in, this gentleman turned and exhibited the ambrosial beard, the symmetrical shape, the monocular appendage, of Captain Lovelock.

The Captain screwed his glass into his eye, and greeted Bernard in his usual fashion—that is, as if he had parted with him overnight.

“Oh, good morning! Beastly morning, isn't it? I suppose you are come to luncheon—I have come to luncheon. It ought to be on table, you know—it's nearly two o'clock. But I dare say you have noticed foreigners are never punctual—it's only English servants that are punctual. And they don't understand luncheon, you know—they can't make out our eating at this sort of hour. You know they always dine so beastly early. Do you remember the sort of time they used to dine at Baden?—half-past five, half-past six; some unearthly hour of that kind. That's the sort of time you dine in America. I found they'd invite a man at half-past six. That's what I call being in a hurry for your food. You know they always accuse the Americans of making a rush for their victuals. I am bound to say that in New York, and that sort of place, the victuals were very good when you got them. I hope you don't mind my saying anything about America? You know the Americans are so deucedly thin-skinned—they always bristle up if you say anything against their institutions. The English don't care a rap what you say—they've got a different sort of temper, you know. With the Americans I'm deuced careful—I never breathe a word about anything. While I was over there I went in for being complimentary. I laid it on thick, and I found they would take all I could give them. I didn't see much of their institutions, after all; I went in for seeing the people. Some of the people were charming—upon my soul, I was surprised at some of the people. I dare say you know some of the people I saw; they were as nice people as you would see anywhere. There were always a lot of people about Mrs. Wright, you know; they told me they were all the best people. You know she is always late for everything. She always comes in after every one is there—looking so devilish pretty, pulling on her gloves. She wears the longest gloves I ever saw in my life. Upon my word, if they don't come, I think I will ring the bell and ask the waiter what's the matter. Wouldn't you ring the bell? It's a great mistake, their trying to carry out their ideas of lunching. That's Wright's character, you know; he's always trying to carry out some idea. When I am abroad, I go in for the foreign breakfast myself. You may depend upon it they had better give up trying to do this sort of thing at this hour.”

Captain Lovelock was more disposed to

conversation than Bernard had known him before. His discourse of old had been languid and fragmentary, and our hero had never heard him pursue a train of ideas through so many involutions. To Bernard's observant eye, indeed, the Captain was an altered man. His manner betrayed a certain restless desire to be agreeable, to anticipate judgment—a disposition to smile, and be civil, and entertain his auditor, a tendency to move about and look out of the window and at the clock. He struck Bernard as a trifle nervous—as less solidly planted on his feet than when he lounged along the Baden gravel-walks by the side of his usual companion—a lady for whom, apparently, his admiration was still considerable. Bernard was curious to see whether he would ring the bell to inquire into the delay attending the service of lunch; but before this sentiment, rather idle under the circumstances, was gratified, Blanche passed into the room from a neighboring apartment. To Bernard's perception Blanche, at least, was always Blanche; she was a person in whom it would not have occurred to him to expect any puzzling variation, and the tone of her little, soft, thin voice instantly rang in his ear like an echo of yesterday's talk. He had already remarked to himself that after however long an interval one might see Blanche, she re-appeared with an air of familiarity. This was in some sense, indeed, a proof of the agreeable impression she made, and she looked exceedingly pretty as she now suddenly stopped on seeing our two gentlemen, and gave a little cry of surprise.

“Ah! I didn't know you were here. They never told me. Have you been waiting a long time? How d'ye do? You must think we are polite.” She held out her hand to Bernard, smiling very graciously. At Captain Lovelock she barely glanced. “I hope you are very well,” she went on to Longueville; but I needn't ask that. You're as blooming as a rose. What in the world has happened to you? You look so brilliant—so fresh. Can you say that to a man—that he looks fresh? Or can you only say that about butter and eggs?”

“It depends upon the man,” said Captain Lovelock. “You can't say that a man's fresh who spends his time in running about after *you!*”

“Ah, are you here?” cried Blanche with another little cry of surprise. “I didn't notice you—I thought you were the waiter. This is what he calls running about after

me," she added, to Bernard; "coming to breakfast without being asked. How queerly they have arranged the table!" she went on, gazing with her little elevated eyebrows at this piece of furniture. "I always thought that in Paris, if they couldn't do anything else, they could arrange a table. I don't like that at all—those horrid little dishes on each side! Don't you think those things ought to be off the table, Mr. Longueville? I don't like to see a lot of things I'm not eating. And I told them to have some flowers—pray, where are the flowers? Do they call those things flowers? They look as if they had come out of the landlady's old cap! Mr. Longueville, do look at those objects."

"They are not like me—they are not very fresh," laughed Bernard.

"It's no great matter—we have not got to eat them," growled Captain Lovelock.

"I should think you would expect to— with the luncheon you usually make!" rejoined Blanche. "Since you are here, though I didn't ask you, you might as well make yourself useful. Will you be so good as to ring the bell? If Gordon expects that we are going to wait another quarter of an hour for him he exaggerates the patience of a long-suffering wife. If you are very curious to know what he is about, he is writing letters, by way of a change. He writes about eighty a day; his correspondents must be strong people! It's a lucky thing for me that I am married to Gordon; if I were not he might write to me—to me, to whom it's a misery to have to answer even an invitation to dinner! To begin with, I don't know how to spell. If Captain Lovelock ever boasts that he has had letters from me, you may know it's an invention. He has never had anything but telegrams—three telegrams—that I sent him in America about a pair of slippers that he had left at our house and that I didn't know what to do with. Captain Lovelock's slippers are no trifle to have on one's hands—on one's feet, I suppose I ought to say. For telegrams the spelling doesn't matter; the people at the office correct it—or if they don't you can put it off on them. I never see anything nowadays but Gordon's back," she went on, as they took their places at table—"his noble broad back, as he sits writing his letters. That's my principal view of my husband. I think that now we are in Paris I ought to have a portrait of it by one of the great artists. It would be such a characteristic pose. I have quite

forgotten his face and I don't think I should know it."

Gordon's face, however, presented itself just at this moment; he came in quickly, with his countenance flushed with the pleasure of meeting his old friend again. He had the sun-scorched look of a traveler who has just crossed the Atlantic, and he smiled at Bernard with his honest eyes.

"Don't think me a great brute for not being here to receive you," he said, as he clasped his hand. "I was writing an important letter and I put it to myself in this way: 'If I interrupt my letter I shall have to come back and finish it; whereas if I finish it now, I can have all the rest of the day to spend with him.' So I stuck to it to the end, and now we can be inseparable."

"You may be sure Gordon reasoned it out," said Blanche, while her husband offered his hand in silence to Captain Lovelock.

"Gordon's reasoning is as fine as other people's feeling!" declared Bernard, who was conscious of a desire to say something very pleasant to Gordon, and who did not at all approve of Blanche's little ironical tone about her husband.

"And Bernard's compliments are better than either," said Gordon, laughing and taking his seat at table.

"I have been paying him compliments," Blanche went on. "I have been telling him he looks so brilliant, so blooming—as if something had happened to him, as if he had inherited a fortune. He must have been doing something very wicked, and he ought to tell us all about it, to amuse us. I am sure you are a dreadful Parisian, Mr. Longueville. Remember that we are three dull, virtuous people, exceedingly bored with each other's society, and wanting to hear something strange and exciting. If it's a little improper, that won't spoil it."

"You certainly are looking uncommonly well," said Gordon, still smiling, across the table, at his friend. "I see what Blanche means——"

"My dear Gordon, that's a great event," his wife interposed.

"It's a good deal to pretend, certainly," he went on, smiling always, with his red face and his blue eyes. "But this is no great credit to me, because Bernard's superb condition would strike any one. You look as if you were going to marry the Lord Mayor's daughter!"

If Bernard was blooming, his bloom at this juncture must have deepened, and in so

doing indeed have contributed an even brighter tint to his expression of salubrious happiness. It was one of the rare occasions of his life when he was at a loss for a verbal expedient.

"It's a great match," he nevertheless murmured, jestingly. "You must excuse my inflated appearance."

"It has absorbed you so much that you have had no time to write to me," said Gordon. "I expected to hear from you after you arrived."

"I wrote to you a fortnight ago—just before receiving your own letter. You left New York before my letter reached it."

"Ah, it will have crossed us," said Gordon. "But now that we have your society I don't care. Your letters, of course, are delightful, but that is still better."

In spite of this sympathetic statement Bernard cannot be said to have enjoyed his lunch; he was thinking of something else that lay before him and that was not agreeable. He was like a man who has an acrobatic feat to perform—a wide ditch to leap, a high pole to climb—and who has a presentiment of fractures and bruises. Fortunately he was not obliged to talk much, as Mrs. Gordon displayed even more than her usual vivacity, rendering her companions the graceful service of lifting the burden of conversation from their shoulders.

"I suppose you were surprised to see us rushing out here so suddenly," she observed in the course of the repast. "We had said nothing about it when you last saw us, and I believe we are supposed to tell you everything, aint we? I certainly have told you a great many things, and there are some of them I hope you haven't repeated. I have no doubt you have told them all over Paris, but I don't care what you tell in Paris—Paris isn't so easily shocked. Captain Lovelock doesn't repeat what I tell him; I set him up as a model of discretion. I have told him some pretty bad things, and he has liked them so much he has kept them all to himself. I say my bad things to Captain Lovelock, and my good things to other people; he doesn't know the difference and he is perfectly content."

"Other people as well often don't know the difference," said Gordon, gravely. "You ought always to tell us which are which."

Blanche gave her husband a little impertinent stare.

"When I am not appreciated," she said, with an attempt at superior dryness, "I am

too proud to point it out. I don't know whether you know that I'm proud," she went on, turning to Gordon and glancing at Captain Lovelock; "it's a good thing to know. I suppose Gordon will say that I ought to be too proud to point *that* out; but what are you to do when no one has any imagination? You have a grain or two, Mr. Longueville; but Captain Lovelock hasn't a speck. As for Gordon, *je n'en parle pas!* But even you, Mr. Longueville, would never imagine that I am an interesting invalid—that we are traveling for my delicate health. The doctors haven't given me up, but I have given them up. I know I don't look as if I were out of health; but that's because I always try to look my best. My appearance proves nothing—absolutely nothing. Do you think my appearance proves anything, Captain Lovelock?"

Captain Lovelock scrutinized Blanche's appearance with a fixed and solemn eye; and then he replied:

"It proves you are very lovely."

Blanche kissed her finger-tips to him in return for this compliment.

"You only need to give Captain Lovelock a chance," she rattled on, "and he is as clever as any one. That's what I like to do to my friends—I like to make chances for them. Captain Lovelock is like my dear little blue terrier that I left at home. If I hold out a stick he will jump over it. He wont jump without the stick; but as soon as I produce it he knows what he has to do. He looks at it a moment and then he gives his little hop. He knows he will have a lump of sugar, and Captain Lovelock expects one as well. Dear Captain Lovelock, shall I ring for a lump? Wouldn't it be touching? *Garçon, un morceau de sucre pour Monsieur le Capitaine!* But what I give *Monsieur le Capitaine* is *moral* sugar! I usually administer it in private, and he shall have a good big morsel when you go away."

Gordon got up, turning to Bernard and looking at his watch.

"Let us go away, in that case," he said, smiling, "and leave Captain Lovelock to receive his reward. We will go and take a walk; we will go up the Champs Elysées. Good morning, *M. le Capitaine.*"

Neither Blanche nor the Captain offered any opposition to this proposal, and Bernard took leave of his hostess and joined Gordon, who had already passed into the antechamber. Gordon took his arm and

they gained the street; they strolled in the direction of the Champs Elysées.

"For a little exercise and a good deal of talk, it's the pleasantest place," said Gordon. "I have a good deal to say; I have a good deal to ask you."

Bernard felt the familiar pressure of his friend's hand, as it rested on his arm, and it seemed to him never to have lain there with so heavy a weight. It held him fast—it held him to account; it seemed a physical symbol of responsibility. Bernard was not re-assured by hearing that Gordon had a great deal to say, and he expected a sudden explosion of bitterness on the subject of Blanche's irremediable triviality. The afternoon was a lovely one—the day was a perfect example of the mellowest mood of autumn. The air was warm and filled with a golden haze, which seemed to hang about the bare Parisian trees, as if with a tender impulse to drape their nakedness. A fine day in Paris brings out a wonderfully bright and appreciative multitude of strollers and loungers, and the liberal spaces of the Champs Elysées were on this occasion filled with those placid votaries of simple entertainment who abound in the French capital. The benches and chairs on the edge of the great avenue exhibited a dense fraternity of gazers, and up and down the broad walk passed the slow-moving and easily pleased pedestrians. Gordon, in spite of his announcement that he had a good deal to say, confined himself at first to superficial allusions, and Bernard after a while had the satisfaction of perceiving that he was not likely, for the moment, to strike the note of conjugal discord. He appeared, indeed, to feel no desire to speak of Blanche in any manner whatever. He fell into the humor of the hour and the scene, looked at the crowd, talked about trifles. He remarked that Paris was a wonderful place after all, and that a little glimpse of the Parisian picture was a capital thing as a change; said he was very glad they had come, and that for his part he was willing to stay three months.

"And what have you been doing with yourself?" he asked. "How have you been occupied, and what are you meaning to do?"

Bernard said nothing for a moment, and Gordon presently glanced at his face to see why he was silent. Bernard, looking askance, met his companion's eyes, and then, resting his own upon them, he stopped short. His heart was beating; it was a question of say-

ing to Gordon outright, "I have been occupied in becoming engaged to Angela Vivian." But he couldn't say it, and yet he must say something. He tried to invent something; but he could think of nothing, and still Gordon was looking at him.

"I am so glad to see you!" he exclaimed, for want of something better; and he blushed—he felt foolish, he felt false—as he said it.

"My dear Bernard!" Gordon murmured gratefully, as they walked on. "It's very good of you to say that; I am very glad we are together again. I want to say something," he added, in a moment; "I hope you wont mind it——" Bernard gave a little laugh at his companion's scruples, and Gordon continued: "To tell the truth, it has sometimes seemed to me that we were not as good friends as we used to be—that something had come between us—I don't know what, I don't know why. I don't know what to call it but a sort of lowering of the temperature. I don't know whether you have felt it, or whether it has been simply a fancy of mine. Whatever it may have been, it's all over, isn't it? We are too old friends—too good friends—not to stick together. Of course, the rubs of life may occasionally loosen the cohesion; but it is very good to feel that, with a little direct contact, it may easily be re-established. Isn't that so? But we shouldn't reason about these things; one feels them, and that's enough."

Gordon spoke in his clear, cheerful voice, and Bernard listened intently. It seemed to him there was an undertone of pain and effort in his companion's speech; it was that of an unhappy man trying to be wise and make the best of things.

"Ah, the rubs of life—the rubs of life!" Bernard repeated vaguely.

"We mustn't mind them," said Gordon, with a conscientious laugh. "We must toughen our hides; or, at the worst, we must plaster up our bruises. But why should we choose this particular place and hour for talking of the pains of life?" he went on. "Are we not in the midst of its pleasures? I mean, henceforth, to cultivate its pleasures. What are yours, just now, Bernard? Isn't it supposed that in Paris one must amuse oneself? How have you been amusing yourself?"

"I have been leading a very quiet life," said Bernard.

"I notice that's what people always say when they have been particularly dissipated. What have you done? Whom have you seen that one knows?"

Bernard was silent a moment.

"I have seen some old friends of yours," he said at last. "I have seen Mrs. Vivian and her daughter."

"Ah!" Gordon made this exclamation, and then stopped short. Bernard looked at him, but Gordon was looking away; his eyes had caught some one in the crowd. Bernard followed the direction they had taken, and then Gordon went on: "Talk of the devil—excuse the adage! Are not those the ladies in question?"

Mrs. Vivian and her daughter were, in fact, seated among a great many other quiet people, in a couple of hired chairs, at the edge of the great avenue. They were turned toward our two friends, and when Bernard distinguished them, in the well-dressed multitude, they were looking straight at Gordon Wright.

"They see you!" said Bernard.

"You say that as if I wished to run away," Gordon answered. "I don't want to run away; on the contrary, I want to speak to them."

"That's easily done," said Bernard, and they advanced to the two ladies.

Mrs. Vivian and her daughter rose from their chairs as they came; they had evidently rapidly exchanged observations, and had decided that it would facilitate their interview with Gordon Wright to receive him standing. He made his way to them through the crowd, blushing deeply, as he always did when excited; then he stood there bare-headed, shaking hands with each of them, with a fixed smile, and with nothing, apparently, to say. Bernard watched Angela's face; she was giving his companion a beautiful smile. Mrs. Vivian was delicately cordial.

"I was sure it was you," said Gordon at last. "We were just talking of you."

"Did Mr. Longueville deny it was we?" asked Mrs. Vivian, archly; "after we had supposed that we had made an impression on him!"

"I knew you were in Paris—we were in the act of talking of you," Gordon went on. "I am very glad to see you."

Bernard had shaken hands with Angela, looking at her intently; and in her eyes, as his own met them, it seemed to him that there was a gleam of mockery. At whom was she mocking—at Gordon, or at himself? Bernard was uncomfortable enough not to care to be mocked; but he felt even more sorry that Gordon should be.

"We also knew you were coming—Mr.

Longueville had told us," said Mrs. Vivian; "and we have been expecting the pleasure of seeing Blanche. Dear little Blanche!"

"Dear little Blanche will immediately come and see you," Gordon replied.

"Immediately, we hope," said Mrs. Vivian. "We shall be so very glad." Bernard perceived that she wished to say something soothing and sympathetic to poor Gordon; having it, as he supposed, on her conscience that, after having once encouraged him to regard himself as indispensable (in the capacity of son-in-law) to her happiness, she should now present to him the spectacle of a felicity which had established itself without his aid. "We were so very much interested in your marriage," she went on. "We thought it so—so delightful."

Gordon fixed his eyes on the ground for a moment.

"I owe it partly to you," he answered. "You had done so much for Blanche. You had so cultivated her mind and polished her manners that her attractions were doubled, and I fell an easy victim to them."

He uttered these words with an exaggerated solemnity, the result of which was to produce, for a moment, an almost embarrassing silence. Bernard was rapidly becoming more and more impatient of his own embarrassment, and now he exclaimed, in a loud and jovial voice—

"Blanche makes victims by the dozen! I was a victim last winter; we are all victims!"

"Dear little Blanche!" Mrs. Vivian murmured again.

Angela had said nothing; she had simply stood there, making no attempt to address herself to Gordon, and yet with no affectation of reserve or of indifference. Now she seemed to feel the impulse to speak to him.

"When Blanche comes to see us, you must be sure to come with her," she said, with a friendly smile.

Gordon looked at her, but he said nothing. "We were so sorry to hear she is out of health," Angela went on.

Still Gordon was silent, with his eyes fixed on her expressive and charming face.

"It is not serious," he murmured at last. "She used to be so well—so bright," said Angela, who also appeared to have the desire to say something kind and comfortable.

Gordon made no response to this; he only looked at her.

"I hope you are well, Miss Vivian," he broke out at last.

"Very well, thank you."

"Do you live in Paris?"

"We have pitched our tent here for the present."

"Do you like it?"

"I find it no worse than other places."

Gordon appeared to desire to talk with her; but he could think of nothing to say. Talking with her was a pretext for looking at her; and Bernard, who thought she had never been so handsome as at that particular moment, smiling at her troubled ex-lover, could easily conceive that his friend should desire to prolong this privilege.

"Have you been sitting here long?" Gordon asked, thinking of something at last.

"Half an hour. We came out to walk, and my mother felt tired. It is time we should turn homeward," Angela added.

"Yes, I am tired, my daughter. We must take a *fiacre*, if Mr. Longueville will be so good as to find us one," said Mrs. Vivian.

Bernard, professing great alacrity, looked about him; but he still lingered near his companions. Gordon had thought of something else. "Have you been to Baden again?" Bernard heard him ask. But at this moment Bernard espied at a distance an empty hackney-carriage crawling up the avenue, and he was obliged to go and signal to it. When he came back, followed by the vehicle, the two ladies, accompanied by Gordon, had come to the edge of the pavement. They shook hands with Gordon before getting into the cab, and Mrs. Vivian exclaimed—

"Be sure you give our love to your dear wife!"

Then the two ladies settled themselves and smiled their adieux, and the little victoria rumbled away at an easy pace, while Bernard stood with Gordon, looking after it. They watched it a moment, and then Gordon turned to his companion. He looked at Bernard for some moments intently, with a singular expression.

"It is strange for me to see her!" he said, presently.

"I hope it is not altogether disagreeable," Bernard answered smiling.

"She is delightfully handsome," Gordon went on.

"She is a beautiful woman."

"And the strange thing is that she strikes me now so differently," Gordon continued. "I used to think her so mysterious—so ambiguous. She seems to be now so simple."

"Ah," said Bernard, laughing, "that's an improvement!"

"So simple and so good!" Gordon exclaimed.

Bernard laid his hand on his companion's shoulder, shaking his head slowly.

"You must not think too much about that," he said.

"So simple—so good—so charming!" Gordon repeated.

"Ah, my dear Gordon!" Bernard murmured.

But still Gordon continued.

"So intelligent, so reasonable, so sensible."

"Have you discovered all that in two minutes' talk?"

"Yes, in two minutes' talk. I shouldn't hesitate about her now!"

"It's better you shouldn't say that," said Bernard.

"Why shouldn't I say it? It seems to me it's my duty to say it."

"No—your duty lies elsewhere," said Bernard. "There are two reasons. One is that you have married another woman."

"What difference does that make?" cried Gordon.

Bernard made no attempt to answer this inquiry; he simply went on—

"The other is—the other is——"

But here he paused.

"What is the other?" Gordon asked.

"That I am engaged to marry Miss Vivian."

And with this Bernard took his hand off Gordon's shoulder.

Gordon stood staring.

"To marry Miss Vivian?"

Now that Bernard had heard himself say it, audibly, distinctly, loudly, the spell of his apprehension seemed broken, and he went on bravely.

"We are to be married very shortly. It has all come about within a few weeks. It will seem to you very strange—perhaps you won't like it. That's why I have hesitated to tell you."

Gordon turned pale; it was the first time Bernard had ever seen him do so; evidently he did not like it. He stood staring and frowning.

"Why, I thought—I thought," he began at last—"I thought that you disliked her!"

"I supposed so, too," said Bernard. "But I have got over it."

Gordon turned away, looking up the great avenue into the crowd. Then turning back, he said—

"I am very much surprised."

"And you are not pleased!"

Gordon fixed his eyes on the ground a moment.

"I congratulate you on your engagement," he said at last, looking up with a face that seemed to Bernard hard and unnatural.

"It is very good of you to say that, but of course you can't like it! I was sure you wouldn't like it. But what could I do? I fell in love with her, and I couldn't run away simply to spare you a surprise. My dear Gordon," Bernard added, "you will get used to it."

"Very likely," said Gordon, dryly. "But you must give me time."

"As long as you like!"

Gordon stood for a moment again staring down at the ground.

"Very well, then, I will take my time," he said. "Good-bye!"

And he turned away, as if to walk off alone.

"Where are you going?" asked Bernard, stopping him.

"I don't know—to the hotel, anywhere. To try to get used to what you have told me."

"Don't try too hard; it will come of itself," said Bernard.

"We shall see!"

And Gordon turned away again.

"Do you prefer to go alone?"

"Very much—if you will excuse me!"

"I have asked you to excuse a greater want of ceremony!" said Bernard, smiling.

"I have not done so yet!" Gordon rejoined; and marching off, he mingled with the crowd.

Bernard watched him till he lost sight of him, and then, dropping into the first empty chair that he saw near him, he sat and reflected that his friend liked it quite as little as he had feared.

(To be concluded.)

COFFEE CULTURE IN BRAZIL.



COFFEE BERRIES ON THE TREE.

IN 1878, Brazil exported more than five hundred million pounds of coffee; a large proportion of this went to the United States. Coffee is the principal product of Brazil, and the coffee tax constitutes a great share of the government revenue.

My exploration of the coffee industry began on the hills around Entre Rios, away back of the Organ Mountains. Here the scenery is quiet; the woods, for the most part, have been cut away; good, hard roads wind through the valleys, and the river is spanned at intervals by stout bridges.

The landscape is purpled with the breath of summer. There, in the swampy ground, the forest is wild and luxuriant yet, with palm-trees and festooned lianas. On either side of the road there are coffee plantations, stretching up the hill-sides. Some of them are dark green, like the green of trailing myrtles; these are strong bearing fields, five or six years old. Others, the worn-out grounds, are full of dead branches, with only two or three green shoots about each root. Others again have just been planted, and the long rows of young trees



COFFEE PLANTATION IN SOUTHERN BRAZIL.

are conspicuous over the neatly weeded surface. The air is full of a perfume like jessamine, wafted from the thick-blooming trees. The dazed insects go reveling in it, dive deep to the honey cups, come out staggering with their strong draught, and tumble over the branches in shameless inebriety.

Carl and I enjoy it all. Carl is my German friend, and we have come up from Rio to study the coffee plantations. He is mounted on a bony horse; I bestride a most disreputable kicking mule; behind us rides our half-breed guide, José. Iron-shod hoofs rattle merrily; the sorry beasts take new life out here on the breezy slopes. Over the purple hills we ride; past white-washed farm-houses and little country stores; down through shady ravines among the tree ferns and great glossy philodendrons; catching glimpses of virgin forest in the valleys; passing mile after mile of coffee-fields on the uplands.

And now a row of cocoa-nut palms comes in sight, and a cluster of roofs in a great walled space, like a prison yard. We draw rein at the folding door. An old negro comes up with bowed head and straw hat held humbly against his breast. He swings the door open for us, and we clatter up the gravel walk to the proprietor's mansion. It

is a large, low building, tile roofed and kalsomined with some light tint; there is a shady piazza, and a few flowering shrubs grow in little inclosed spaces before it; beyond this, we see no attempt at ornament. In front of the house, there in an immense smooth pavement of concrete, occupying half an acre or more, and with a low wall around it; this is the *terreiro*, on which coffee is dried. Beyond, are the various mills and workshops, and the negro quarters, opening toward the master's house; there may be twenty buildings in the cluster,—all neat and substantial, but as unpicturesque as possible.

"Come in, gentlemen," cries Senhor S—, meeting us at the steps and shaking hands with us as we alight. S— is a big, burly fellow, rosy, like an Englishman, and not at all ceremonious. We are invited to seat ourselves on the piazza, while he reads our letters. We explain that we wish to remain for a few days, that we may study plantation life more closely.

"*Pois não?* Why not? A room shall be prepared at once. Meanwhile, let us breakfast."

As our host is a bachelor, there are no introductions. The breakfast—a very good one—is discussed amid much pleasant conversation. Two or three negro servants

stand behind our chairs, but, like most Brazilian house-servants, they serve more for show than for use. The dining-room is large and bare. At one side there is a writing-desk, with a few books, mostly agricultural manuals and government reports—Portuguese and French. Two or three unartistic pictures adorn the walls; the furniture is solid and angular, and badly matched. Retiring to the parlor to smoke our cigarettes, we find that apartment very little better. There is a piano, of course; the furniture is rich, but tasteless, and is set at right angles. There is not a single book in the room, and, save the agricultural treatises, none in the house. Our host was expensively educated in Europe, and he is naturally intelligent and progressive; but, like many other Brazilian planters, he is entirely absorbed in his plantations. Beyond the coffee-trees, and the slaves, and the *milreis* that he may gain from them, he has very little interest in the world and its doings.

He discourses of the plantation and the improvements that he is introducing. This was one of the old-time estates that had fallen into negligence and decay. Senhor

apparently worn-out land. There are 4,000 acres in the estate, 2,200 of which are under cultivation. The rest is virgin forest. The fields count 400,000 bearing coffee-trees, and our host is just planting as many more. Large plots also are appropriated to corn, beans, etc., wherewith the two hundred slaves are fed.

In southern Brazil, a coffee-field seldom lasts more than thirty years. The plantations are made on the fertile hill-sides, where the forest has been growing thick and strong. But the soil here is never deep—six or eight inches of mold at the utmost. In the tropics there are no long winters with mats of dead vegetable matter rotting under the snow. The leaves fall singly, and dry up until they break into dust; logs and decaying branches in the shady woods are carried away by white ants and beetles; hence the mold bed increases very slowly; in twenty-five or thirty years, the strong-growing coffee-trees eat it all up. Most planters simply cut down the forest and leave the trees to dry in the sun for six or eight weeks, when they are burned. S—, more provident, lets the logs rot where they lie, which they do in a



THE VIVEIRO.

S— has brought young vigor and driving management to it. He has abandoned the old tracks, introduced new machinery and new ideas, and his neighbors are astonished to see the wonderful results obtained from

year or two; in the open sunlight they are saved from insects, and the ground receives a large accession to its strength.

Back of the house there are two yards or small fields, four acres, perhaps, together.

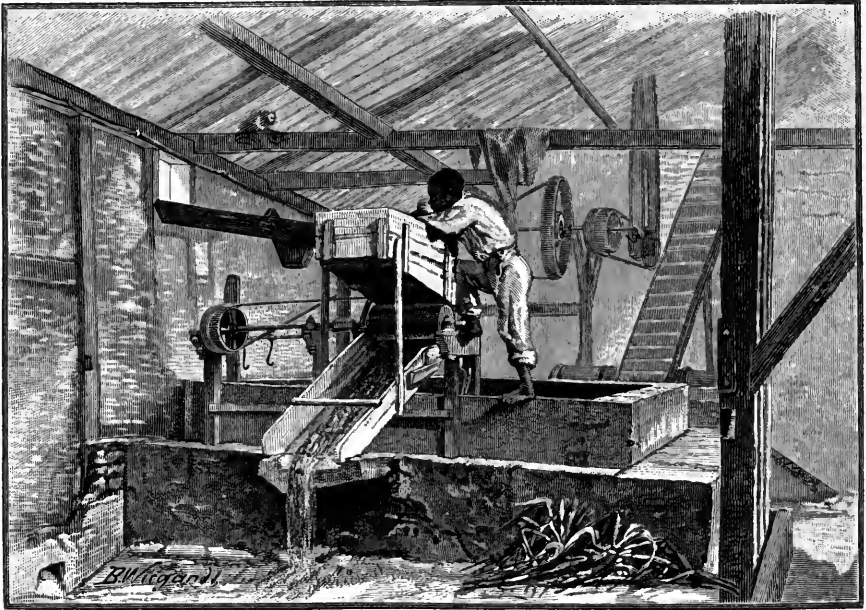

THE PULPING-MACHINE.

The ground is covered with earthen pots set close together, only leaving little pathways at intervals. Each of the two hundred thousand pots contains a thriving young coffee-plant. The ground forms a gentle slope, and water is constantly running over it, so that it is always soaked. The pots, through orifices at the bottoms, draw up enough of this water to keep the roots moistened. The young plants are protected from the sun by mat screens stretched on poles above the ground.

This is a costly system. Most of the planters take root shoots at random from the old fields and set them at once into unprepared ground. Sr. S——'s experiment has cost him probably \$20,000; the pots alone cost \$11,000. But he will make at least \$50,000 by the operation. In the first place, he gains a good year in the start that he gives to these young plants. Then they are not put back in the transplanting; the pots are simply inverted and the roots come out with the earth. They are set into mold or compost which has been prepared in deep holes. The tender rootlets catch hold of this at once, and in a day or two the plant is growing as well as ever.

The nurslings come from selected seeds of half a dozen varieties. Sr. S—— has them planted at first in small pots. A dozen slaves are engaged transplanting the six-inch high shoots to larger pots. Little tired-

looking children carry them about on their shoulders, working on as steadily as the old ones, for they are well trained. Sr. S—— wants to make his plants last fifty years, so he is careful and tender with them. The little blacks will be free in 1892, so his policy is to get as much work as possible from them while he can.

The plants are set in rows, about ten feet apart. They grow, and thrive, and are happy, out on the hill-side. Warm sunshine caresses the leaves; generous rains feed the tender roots; the ground is kept free from intruding weeds and bushes, and the planter waits for his harvest. After four years, the trees are six feet high and begin to bear. By the sixth year, the crops are very large,—three or even four pounds per tree at times. Meanwhile, corn and mandioca are planted between the rows. Often in a new plantation the expenses are nearly covered by these subsidiary crops.

In this month of November only a few of the slaves are in the new fields. November is the principal gathering month, and almost the whole force must be at work in the bearing orchards. From sunrise to sunset, men, women, and children are gathering the berries in baskets, working silently and steadily under the overseer's eye. Every day, each slave gathers on the average berries enough to produce fifty pounds of dried coffee. The pickings are col-



PICKING COFFEE.

lected in carts and brought to the mill-house, where the seeds must

tough shell, the *casca*, which, in turn, is surrounded by a thin white pulp and outer skin, forming the berry. Nearly all the processes of preparation seek, first, the removal of the outer pulp by maceration in water; second, the drying of the seeds with their coverings; third, the removal of the several coverings after they are dry. To these three processes is sometimes added a fourth, by which the seeds are sorted according to their forms and sizes.

On the hill-side above the mills, there is a cement-lined trough, through which a strong stream of water is running. This water has been carefully cleansed by a series of strainers, and the trough is covered to keep out rubbish. Through a funnel-shaped opening, the coffee berries are thrown into the stream, which carries them down with it to a large vat; from the bottom of this vat, a pipe draws off the heavier berries to the pulping machine (*despolpador*), while the lighter and almost valueless ones are floated off

be prepared for the market. And now let us consider the processes of preparing it.

The coffee-berry is a little larger than a cranberry, and something like one in appearance. Each of the two seeds is enveloped in a delicate membrane, the *pergaminho*. This being strongly adherent can only be removed by strong rubbing, even when the seed is dry. Outside of the *pergaminho* there is a thicker and loose covering, the *casquinho*. The two seeds, with their respective inner and outer coverings, are together enveloped in a

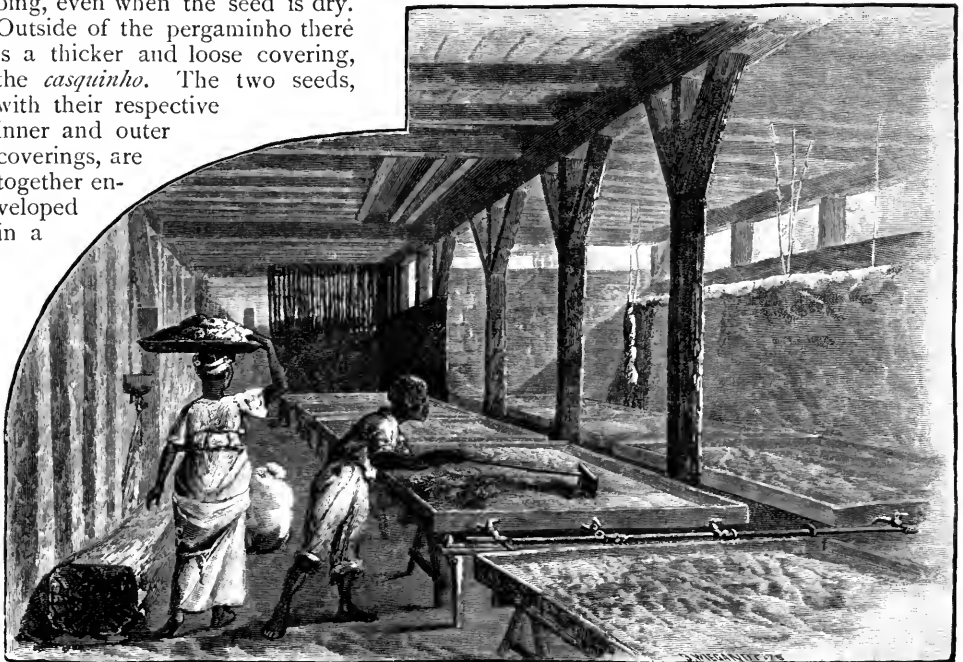

STEAM DRYING-MACHINE.

with the surface water to another pipe. The pulping machine is simply a revolving iron cylinder, set with teeth and covered on one side by a curved sheet of metal against which it impinges as it turns. The berries, carried to the cylinder with the stream of water, are crushed between it and the cover and the pulp is thus loosened. Passing from the pulping machine to a vat beyond, the water is kept in constant motion by a rapidly revolving wheel; by this means the pulp is thoroughly washed off and carried away with the water, while the heavier seeds sink to the bottom; thence they are carried to a strainer which drains off the water and leaves the seeds ready for the next stage.

Thus far the process employed on Sr. S——'s plantation is similar in principle to that seen elsewhere; the tanks and troughs are indeed more elaborate in their arrangement, and hence the outer pulp is washed away more thoroughly. The seeds are still inclosed, two together, in the outer and inner shells.

The next process—that of drying—is effected in two different ways. Both of these are employed on this plantation. The great cement-covered pavement in front of the house is the *terreiro*, used in the old process; the seeds are simply spread out on it and allowed to dry in the sun. About sixty days are required for this. Meanwhile the seeds must be raked over and turned during the day and gathered into piles and covered at night, or before rains. When a sudden shower comes up, the *terreiro* is picturesque with moving figures of slaves, employed in this work; for the rest, it is unpicturesque enough, like everything else about a coffee plantation except the negroes.

Sr. S——, ever ready to avail himself of all modern improvements, is adopting the new system of drying by steam. Back of the house there is a long, low building, which one hesitates to enter on account of its sweltering heat; within, a light vapor floats about the roof and is carried away through openings under the eaves. We see rows of great zinc-covered tables with raised edges, and steam-pipes running beneath them; little clouds come from the drying coffee on these tables; one or two negroes move about, stirring the seeds here and there, and removing them as they are dried. This steam process is likely to supplant the old system entirely, for by it the coffee is dried thoroughly in a few hours, and the long de-

lay of the *terreiro* is done away with, while the product is much improved in quality. Against the expense of the drying machine, which is not very great, is also to be set the

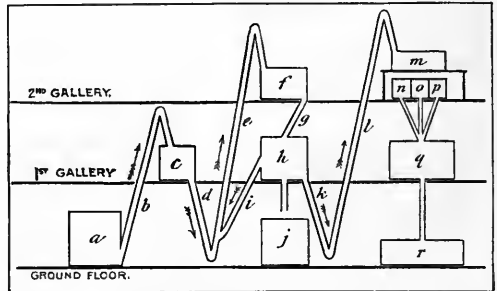

DIAGRAM OF A COFFEE ENGENHO.

absolute saving of labor; three, or at most four, workmen will attend to twenty tables, which are quite enough for the largest plantation; the coffee runs no danger of injury by rains, and, the process being a constant and rapid one, there is no accumulation of half-prepared seeds.

The coffee grains are still inclosed in their inner and outer shells, now dry and somewhat brittle. The removal of these is effected by a much more complicated and expensive process. The first impression produced by Sr. S——'s mill-house is one of utter confusion. It is a large, substantial building, such as might be used for a fanning-mill in the United States. The floor and two galleries above it are occupied by a series of complicated mechanisms; some of them like threshing machines, some like fanning-mills, some like nothing at all that a Northern reader is familiar with—all in motion with a constant clatter and grinding and pounding, by which, somehow, nicely cleaned coffee grains are evolved from the dirty-looking, nut-like shells that come from the drying tables. You think that so small a result might have been obtained by a less complicated and expensive apparatus. There are, indeed, less formidable mills, in which the work is done by two or three machines; these are found on smaller plantations, where the planter is satisfied with a mediocre product, and only a few hundred or thousand arrobas (thirty-two pounds each) of coffee are prepared each year. But Sr. S——'s plantation turns out annually from sixteen to eighteen thousand arrobas, and in a few years the yield will be greatly increased; his mills must shell and clean all this in two or three

months. The large number of machines secures not only greater nicety in the result, but a far greater amount of work in a given time. The thirty thousand dollars expended on the mill-house and mills was wisely laid out; all the great coffee planters are adopting these improved machines, most of which are of American invention and make. Many of the small proprietors bring their coffee to the large *engenhos*, as a Northern farmer brings his grist to the miller.

A machine described is as uninteresting as a machine before the eyes is attractive. Carl and I spend half a day in studying the mill-house, but it will be better to epitomize the process here in a rough diagram.

The dried coffee nuts are brought to the mill-house in baskets, and deposited in a bin, *a*. Thence they are carried by a band elevator, *b*, to the ventilator, *c*, where sticks and rubbish are sifted out and the dust is fanned away. Now the coffee passes down through the tube *d* to another elevator, *e*, which carries it to the sheller (*descascador*), *f*, where the outer and inner shells (*casco*, *casquinho*) are crushed by revolving toothed cylinders. The grains and broken shells pass through a pipe, *g*, to the ventilator, *h*, where the shells are sifted and fanned away; the unbroken nuts are separated on a sieve, and passed by the pipe, *i*, back to the elevator, *e*, and so again to the sheller; the shells and rubbish fall into a bin, *j*, from which

they are removed for manure; the coffee grains fall into the pipe, *k*, and are carried by the elevator, *l*, to the separator, *m*. This separator is composed of a pair of hollow revolving copper cylinders, pierced with



PICKING OVER COFFEE.

holes of different sizes and shapes; the coffee grains, dropped into the cylinders, fall through these holes, and are assorted by them into large and small, flat and round, grains, which pass into different bins, *n*, *o*, *p*. There still remains a portion of the fine inner covering of the grains (*pergaminho*). This is removed in the *brunidor*, *q*, with constant shaking, trituration and fanning. Falling into the bin, *r*, the cleaned coffee is removed and carefully picked over by hand, before it is finally consigned to the sacks.

These machines are the outgrowth of many years

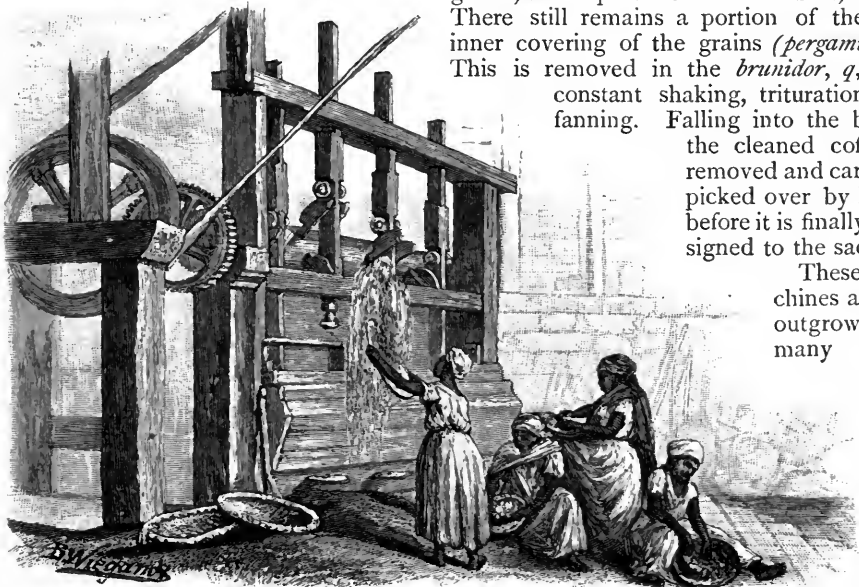

COFFEE-SHELLER (OLD STYLE).

of study. Time was when the shells were broken in great wooden mortars, with immense labor; and even now on a great proportion of the plantations, the work is done in larger mortars with great metal-

moved, partly by a turbine wheel, but principally by a large steam-engine, which Sr. S—— shows us with pardonable pride. From the machine house he takes us to his stock-yard, which, though an entirely sub-



SUNDAY MORNING.

shod pestles, moved by steam or water power. In place of the ventilators also, one sees shallow hand-sieves, which the negro women use with wonderful dexterity, separating the fine dust, and tossing out the shells with a peculiar twist of the hands.

A large plantation, like that of Sr. S—— is a little world in itself; there are smithies and workshops, machines for preparing mandioca, a saw-mill, a corn-mill, a sugar-cane mill, and a still where the cane-juice is made into rum. At one end of the inclosure there is a brick-kiln, and near by a pottery, where most of the pots in the *viveiro* were prepared. The machinery is

sidinary business, is by no means insignificant; there are eighty-five oxen and nearly thirty mules, a hundred swine and fifty sheep, with innumerable turkeys, fowls, guinea-hens and pigeons. To crown all, there is a Zebu ox from India, which Sr. S—— bought in Paris, and imported for experiment.

Picturesque groups of washerwomen gather about the great stone basin, where their work is done. Every morning we hear the clatter of a chopping machine cutting up sweet cane-tops for the cattle. In the kitchen, the slave rations are prepared in great kettles and ovens. Here a blacksmith is busy at his forge; there a carpenter is hammering or sawing. Among all we do not see an idle negro, for even the white-headed octogenarians are employed, in basket-weaving, or other light work, and all the children, except the merest babies,

must go to the fields with the rest. On Sunday, a few of the weakest gather about the quarters and indulge in something like recreation.

The negroes are kept under a rigid surveillance, and the work is regulated as by machinery. At four o'clock in the morning all hands are called out to sing prayers, after which they file off to their work. At six, coffee is given to them; at nine,

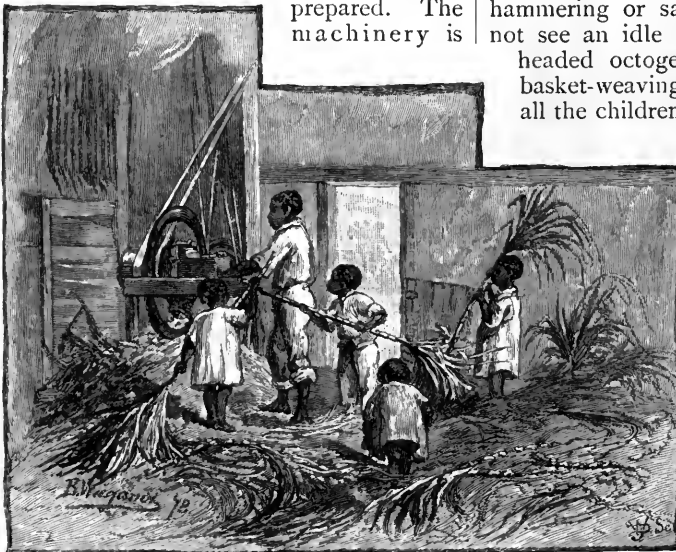

CUTTING CANE-STALKS FOR THE CATTLE.

they breakfast on jerked beef, mandioca meal, beans, and corn-cake; at noon, they receive a small dram of rum; at four o'clock, they get their dinner, precisely like the breakfast, and, like that, served in the fields, with the slightest possible intermission from work. At seven, the files move wearily back to the house, and draw up before the overseer or master, to the sound of a bugle from the tripod at one side; a bright fire half illumines,

policy he treats him well, as he would his horse; he does not wish to diminish the value of his property. But if the slave is to be freed in ten or fifteen or twenty years, the policy of the master is to get as much service as possible out of him. A young, able-bodied negro, even if he is overworked and cruelly treated, may reasonably be expected to last twenty years; humane masters may look beyond that and treat their slaves

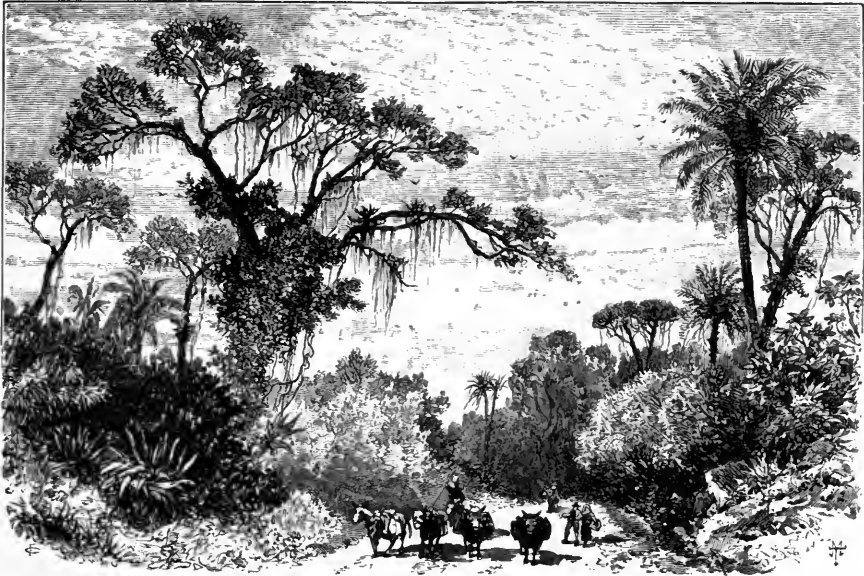

ROAD NEAR ENTRE RIOS.

half conceals, the dark figures, sending flashes over the walls beyond and casting long shadows on the ground. The tools are deposited in a store-house and locked up; two or three of the crowd, perhaps, advance timidly to make requests of the master; then all are dispersed to household and mill work until nine o'clock; finally, the men and women are locked up in separate quarters, and left to sleep seven hours, to prepare for the seventeen hours of almost uninterrupted labor on the succeeding day. Some masters, of course, work their slaves with more humanity. On Sunday there is a nominal holiday, which practically amounts to three or four hours of rest; none of the saint days are celebrated here, and even Christmas is passed unnoticed.

The Brazilian system of gradual emancipation, however wise it may be in some respects, brings with it an inevitable evil. If a man has unrestrained control of his slave as long as the latter may live, from

well, but the majority see the matter simply in a business light. If a man is foolish enough to let his horse for five years, he must expect to get back a poor, broken-down animal. Yet he who hires the horse or the slave may be rather blinded than naturally cruel,—blinded by that thickest of all bandages, business.

All through the provinces of Rio de Janeiro and São Paulo are scattered great plantations like this of Sr. S——; some, indeed, are even larger, embracing a million trees or more, and employing many hundred slaves. Small plantations are numerous; but many of them are deeply in debt, and their success is altogether problematical. A vast share of the profits of coffee-planting is absorbed by the large proprietors, who, with two or three hundred slaves and scores of labor-saving machines, can easily outstrip their poorer neighbors. The present financial system of Brazil encourages the rich planter and retards the poor one. There is

no land-tax; the best coffee-lands are all taken up by capitalists, who hold them for years uncultivated. Eventually, with the extension of internal communication and the increased demand for planting-grounds, they secure enormous profits. The ground held by Sr. S—— was purchased twenty-five years ago, at the rate of \$10 per acre; the portion that still remains as forest is now worth at least \$75 per acre, in the open market.

An American can better comprehend these evils, by reflecting upon the results which a similar system would have brought to the United States. Suppose that no land-tax had been imposed in our western territories; the whole country would have been bought up by speculators; purchasers for a few cents or dollars an acre would have held hundreds of square miles; the land would have risen to a fictitious value, a few rich men would have acquired enormous fortunes, and immigrants would have been kept out by the high prices and the difficulty of obtaining farms. Immense tracts would still be lying idle, and instead of controlling the grain trade of the world, the United States might now be buying of other countries. Such results would only be the legitimate outgrowth of a system by which land, ever increasing in value, could be held without limit or restriction.

So Carl and I reason as we ride back to Entre Rios in Sr. S——'s great traveling carriage. We admire the enterprise and keenness of our host; we would be ungrateful if we did not acknowledge his ready hospitality and kindness. None the less he is growing richer by the force of unjust laws and unrighteous tyrannical institutions; witness the neglected grounds of his poorer neighbors and the smileless faces of his slaves.

The four mules canter on briskly over the hard ground. Presently we turn into the *União e Industria* road,—the finest in Brazil, and formerly the only outlet of these regions. It was built by a private company who run on it a line of stages and freight wagons. From the head of the bay of Rio de Janeiro far into the province of Minas Geraes, the road is lined everywhere with rich coffee plantations. The planters send their produce to Entre Rios by this route, sometimes to Rio. Tolls are levied at intervals; with these and the stage charges, the company reaps a rich harvest.

With a tinkling of bells and a patter of hoofs, the mule trains pass on down the

road. The animals walk in single file, each one with a pair of coffee sacks slung from the rough pack frame; behind them come the muleteers, mounted or on foot, and dressed in the picturesque, half European costume of the Brazilian country people. Nearly all the coffee is brought to the rail-roads in this manner. Formerly the rough paths did not allow of any better conveyance. Now there are many good roads about Rio and São Paulo, but even when these are available, the planters cling to the old system; only a few use wagons.

Entre Rios is on a branch of the Dom Pedro Segundo railway, where the latter meets the *União e Industria* road. From its situation, the little country town promises to become a thriving inland city, the metropolis of this rich coffee region. The hills around are covered with plantations, each with its white walled *fazenda*, like a castle; odd contrasts to these are the jaunty, modern-looking railroad station, and the attendant hotel, which might be a country tavern in the United States. Mule trains come to discharge their cargoes at the station; bags of coffee are piled on the platforms and cars are being loaded with them; a store-house near by is half filled with coffee awaiting shipment. From the titled gentleman who passes you, to the dapper landlord, and the merest day laborer, everybody in Entre Rios is dependent on coffee; the streets and buildings are fragrant with coffee; people drink coffee at the restaurant and quote coffee prices; sell coffee, buy it, plant it, gather it, live and labor with very little thought beyond coffee and the golden stores it will bring into their purses. The railroad was built to carry away the coffee; that is its main business, almost its only income, for of other freight there is very little; there are not many passengers, and of them ninety per cent. are coffee planters or coffee traders.

The smooth, well-built route passes up the picturesque valley, by coffee plantations everywhere, until it joins the main line from São Paulo to Rio. Then we wind up the mountains, passing through a score of tunnels, clinging to the sides of giddy precipices, peering up from cavern-like valleys, dashing on by forest so wild and luxuriant that it almost rivals that of the Amazons. The brown gneiss rises above us in strange peaks, mountains of goodly size. Itatiaia, the highest of all, is capped with clouds; its summit is almost ten thousand feet above the sea, so that snow is

sometimes found there, and palms cannot grow among the rocks.

The mountains are grand and picturesque beyond all description; the railroad, too, merits all the praises that have been lavished on its construction, for it is a triumph of engineering and workmanship. In fact one who travels over the road is very apt to let his admiration run away with his judgment. For a moment let us consider the road aside from the mountains and tunnels, on the question of bare utility.

The Dom Pedro Segundo railroad is the largest and, with perhaps one exception, the most important in Brazil. The total length of the main line is 365 miles, and extensions are made almost every year. The road was commenced under the management of an incorporated company, interest of 7 per cent. on the capital stock being guaranteed by the government. But in building the first portion of the road, it was necessary to cross the mountains near Rio, and so difficult and expensive was this work, that by the time one hundred miles were completed, the capital was entirely exhausted. In 1865, the government bought the road of the stockholders, and it has since been built and run as a branch of the imperial service. The road, as we have seen, is finely constructed; it is regular and safe; the stations and store-houses are well built and tasteful; the coaches are comfortable and the ordinary traveler, at least, has no fault to find with the officials. On the invested capital of rather more than \$40,000,000, the government realizes an average income of five and one-half per centum yearly. So far the result is good; the road is well managed, and is a source of actual gain to the government. Let us see if the practical results to the people are equally good.

Coming down about ninety miles from Entre Rios, we paid 9,900 reis each for our tickets, say four dollars by existing exchange. This is a high but not an exorbitant rate; second-class tickets are just one-half as much, and "excursion tickets," good for both ways, can be had at a reduced price. Our light satchels cost us nothing, of course; but if we had had trunks, even small ones, we should have had to pay as much for them as for ourselves. A fellow-passenger brought down five goats from Entre Rios,—9,900 reis he paid for himself, and 9,900 reis for every one of the goats.

The regular tariff on coffee from Entre Rios to Rio is 2,000 reis,—about 85 cents per sack of 60 kilograms. Corresponding

rates are charged from more distant places, and on branch roads. From certain portions of São Paulo, every sack of coffee that reaches Rio or Santos must pay four dollars, or about one-third of the actual value in the Rio markets. The regular freight charges from Rio to New York vary from twenty to seventy-five cents per sack.

Portions of São Paulo and Minas Geraes are well fitted for growing corn and even wheat, and it has often been suggested that these districts should supply Rio with bread-stuffs. But if São Paulo grain or flour were brought to Rio by railroad, it could never compete with American produce; nay, it is a demonstrable fact that it could be undersold by California grain, brought by way of the Pacific Railroad to New York, and thence by sailing vessels to Rio.

The freight rates on the Dom Pedro Segundo railroad are cheaper by one-third than those on any other railroad in Brazil. Only three or four lines are paying a reasonable percentage on their invested capitals, and many would have to be abandoned altogether but for the government guarantee of seven per centum annually. Of course, these roads are a heavy drain on the government, and hence on the country, and the high freights neutralize any commensurate gain which might accrue to the districts through which they pass. Even the Dom Pedro Segundo line is a doubtful advantage. Plans have more than once been discussed for bringing coffee to Rio by mule trains, and it is averred that this could be done at a lower rate than that demanded by the railroad.

Brazilians are crying out against these excessive tariffs, but the remedy is not apparent. No public or private railroad can afford to carry freight at a rate that involves a dead loss, or leaves no margin for profits. Most of these roads were built with the idea of "opening up," or "developing" this or that region; that is, the railroads were expected to bring prosperity to the country; but it was not always clear that the country could give prosperity to the railroads. If a steady stream of working immigrants had been flowing in, such reasoning might *perhaps* be good. But Brazil gets few immigrants, and the quality of these few is not of the best; the development of new districts means simply a spreading out of the present resources, not an actual increase of production.

I believe that the mistake of Brazilian railroad schemes is that they do not consider

the status of the population. In the northern provinces a large proportion of the poorer people are non-producers; that is, they cultivate only small tracts, and raise enough mandioca and corn for their own use, but almost nothing more. The large plantations are few and scattered; the products, sugar, cotton, hides, etc., are not enough to support a railroad even with the present high freights. In the south, a large portion of

States would necessitate shipments of coal, provisions, cloths, and a thousand articles of luxury, all of which would be clear gain to a railroad, and no slight addition to the incoming freights.

No railroad, which depends for its prosperity on coffee alone, can afford to establish a low freight tariff. Hence, the extent of such a road must be limited; for ultimately a point will be reached from which the

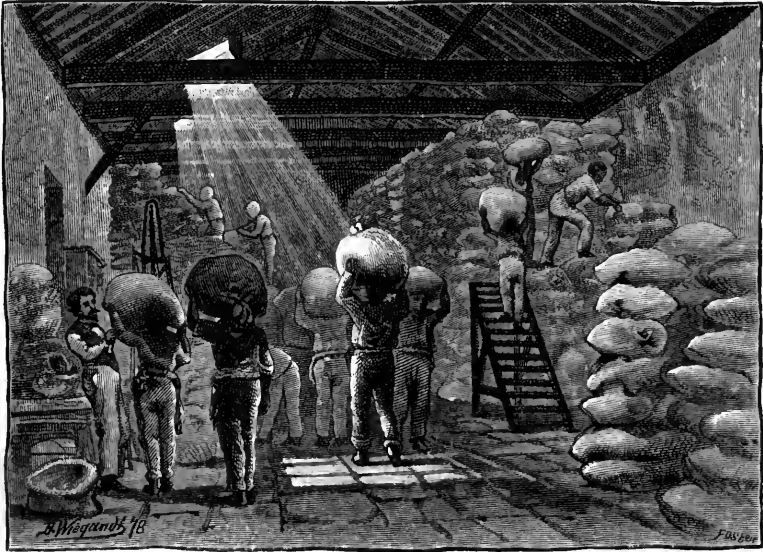

COFFEE WAREHOUSE.

the ground is taken up by rich coffee planters, who cultivate only portions of the ground. Now, the utmost yield of coffee is four or five hundred pounds per acre; if a railroad drains one thousand square miles of coffee land, it can carry away no more than 300,000,000 or 400,000,000 pounds of coffee annually, while the same extent of wheat or corn land would produce at least ten times as much freight. Practically, the discrepancy is still greater. The province of São Paulo, with its two draining railroads, probably does not furnish one-thirtieth of the freight that is supplied by an equal extent of our Western grain-lands. Moreover, the great proportion of the population of coffee districts consists of slaves; their food is furnished by the plantations, and their clothes are few and scanty. To a plantation like that of Sr. S——, the railroad brings nothing but the machinery and tools, with the furniture of the master's house, and a few bales of cloth for the two hundred slaves. An equal population in the United

freights will be so high that practically exportation will be prohibited. Brazilians talk of extending their railroads into Matto Grosso, eight hundred miles from the sea; but to what purpose? Coffee cannot be cultivated there, because it cannot be exported, and there is no inflow of immigrants to establish grain farms, as in our Western states. I believe that for the present Brazil should let these central regions alone. She should seek to condense and enrich her coast population; and, when new fields are required, there is the Amazonas valley, an inexhaustible garden, with free water communication to the ocean.

Sometimes the coffee is sold to traders at the railroad stations. More commonly, the planters employ agents, or factors, at Rio de Janeiro, who sell the coffee, for a small commission, to the packers (*ensacadores*). To these latter belong the great store-houses in the northern and eastern part of the city. Here there are hundreds of negro porters, carrying the heavy sacks

on their heads, or waiting at the street-corners for a job. The most of these are slaves; but some are free, and earn from \$1.50 to \$2 per day. They work often with bare bodies and arms, showing their

porters bring them in, each bag is probed, and a handful of grains are taken out for samples. Subsequently the coffee is emptied out on the floor, and repacked in coarse sacks for shipping, the weight being carefully

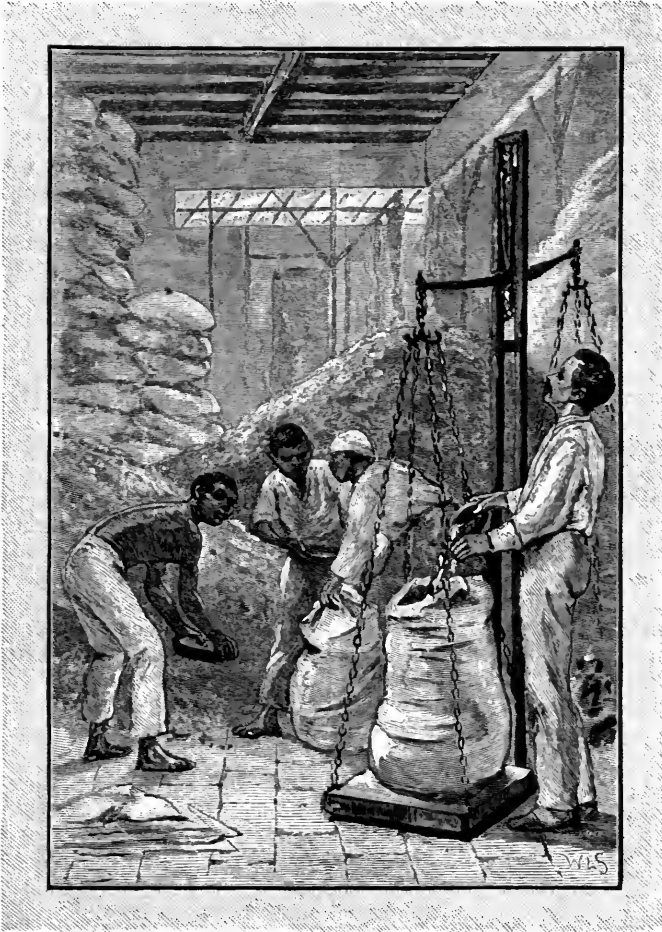

WEIGHING.

superbly developed muscles; but the severity of their labor is evinced by diseased hips and intumed knees; very few of these porters attain the age of fifty years.

We find ready admittance to a store-house, and the overseer takes pains to explain the different processes. It is a great, barn-like room, level with the pavement, and substantially floored and walled. The coffee-sacks are piled on either side, each pile bearing a separate mark, and each sack distinguished by a number. The incoming loads are brought from the railroad station in trucks and horse-cars. As the

adjusted to 60 kilograms, or a little over 132 pounds. The old sacks bear the mark of the planter from whom they came, and they are returned to him through the agent.

The packers are speculators, buying the coffee outright, and selling it when they can do so to best advantage, of course avoiding the expense of a long storage. From the packer the coffee goes to the exporter, who is in correspondence with American or European houses, and who depends for his profits on the New York or Baltimore or London markets. With him, also, the purchases must be a matter of speculation and

calculation ; for, during the ocean transit of from three to seven weeks, the markets may fluctuate greatly. Sometimes a high price can be looked for at an early day, and then the exporter makes his shipments by steamer, to secure a quick passage ; but at other times the markets require delay, and sailing vessels get the preference. Some shipments are very large ; single houses frequently send off eight or ten thousand bags by one steamer. The whole immense business centers in a few dingy counting-rooms, where American or English merchants control a million pounds of coffee with a stroke of the pen.

Rio and Santos are the two great coffee ports of Brazil, and the three provinces of Rio de Janeiro, São Paulo, and Minas Geraes produce almost all the coffee that is sent out of the country. But if the story runs truly, the northern provinces have the honor of the first introduction of coffee-plants. As is well known, the tree is a native of Arabia and North-eastern Africa, but it had been introduced into America in the early part of the 18th century. It is related that a Portuguese traveler, visiting Cayenne about 1750, received a handful of coffee-berries from the wife of the French governor. The seeds from these were planted near Pará, and from them sprang the first coffee-trees in Brazil. At one time there were many small coffee-orchards along the Amazons and perhaps a small exportation. Even now a few trees are

cultivated about the plantations and villages, and the seed derived from these is of a very superior quality, probably the best in Brazil. But it would be hard to convince a Brazilian that coffee could be successfully grown in the northern provinces.

The coffee-plant was first introduced into Rio in 1774, but it was long before it became an article of export. In 1800, ten sacks were sent out of this port, and in 1813, twelve sacks. In 1817, the first large shipments took place, about 64,000 sacks. From that time until 1851 the exportation steadily increased, reaching in the latter year over two million sacks, or 330,000,000 pounds. Since that the increase has never been very great, and at times there has been a falling off in the yearly product. The want of growth is due, no doubt, to the ruinous system of cultivation, which robs the ground without enriching it ; to the high freight tariffs and consequent uselessness of the interior lands, and to the export duties, which may eventually ruin the industry altogether. Of late, other countries are turning their attention to coffee, and as soon as their young plantations are grown they will compete with Brazil in the markets of the world. Mexico, especially, is likely to be a powerful rival, and if coffee is sent from her ports free of duty, she may eventually force Brazil to lower or remove her export tariffs, now the chief sources of her revenue.

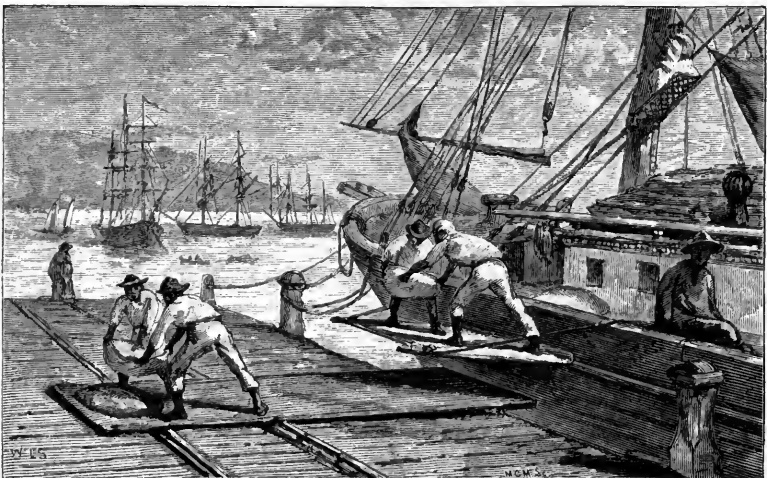

WHARF SCENE AT RIO DE JANEIRO.

SUCCESS WITH SMALL FRUITS. II.

STRAWBERRIES FOR HOME AND MARKET.

PREPARING AND ENRICHING THE SOIL.

HAVING from choice or necessity decided on the ground on which our future strawberries are to grow, the next step is to prepare the soil. The first and most natural question will be, What is the chief need of this plant? Many prepare their ground in a vague, indefinite way. Let us prepare for strawberries.

Whether it grows north or south, east or west, the strawberry plant is the same, and has certain constitutional traits and requirements, which should be thoroughly fixed in our minds. Modifications of treatment made necessary by various soils and climates are then not only easily learned but also easily understood. When asked what was the chief requirement in successful strawberry culture, Hon. Marshall P. Wilder replied: "In the first place, of the strawberry's chief need is a great deal of water. In the second place, it needs more water. In the third place, I think I would give it a great deal more water." And this is true. Without moisture the best of fertilizers become injurious rather than helpful. Therefore, in the preparation of the soil and its subsequent cultivation, there should be a constant effort to secure and maintain moisture, and the failure to do this is the chief cause of meager crops. And yet, very probably the first step absolutely necessary to accomplish this will be a thorough system of underdrainage. I have spent hundreds of dollars in such labors, and it was as truly my object to enable the ground to endure drought as to escape undue wetness. Let it be understood that it is *moist* and not *wet* land that the strawberry requires. If water stands or stagnates upon or a little below the surface, the soil becomes sour, heavy, lifeless; and, if clay is present, it will bake like pottery in dry weather and suggest the Slough of Despond in wet. Disappointment, failure and miasma are the certain products of such unregenerate regions, but, as is often the case with repressed and troublesome people, the evil traits of such soils result from a lack of balance, and a perversion of what is good.

If, however, we have mellow upland with natural drainage, let us first put that in order that we may have a remunerative crop as soon as possible.

In suggesting, therefore, the best methods of preparing and enriching the ground, I will begin by considering soils that are already in the most favorable conditions, and that require the least labor and outlay. Man received his most essential agricultural instructions in the opening chapter of Genesis, wherein he is commanded to "subdue the earth." Even the mellow Western prairie is at first a wild, untamed thing that must be subdued. This is often a simple process, and in our gardens and the greater part of many farms has already been practically accomplished. Where the deep, moist loam, just described, exists, the fortunate owner has only to turn it up to the sun and give it a year of ordinary cultivation, taking from it, in the process, some profitable hoed crop that will effectually kill the grass,—and his land is ready for strawberries. If his ground is in condition to give a good crop of corn it will also give a fair crop of berries. If the garden is so far "subdued" as to yield kitchen vegetables, the strawberry may be planted at once, with the prospect of excellent returns, unless proper culture is neglected.

Should the reader be content with mediocrity, there is scarcely anything to be said where the conditions are so favorable. But suppose one is not content with mediocrity. Then this highly favored soil is but the vantage ground from which skill enters on a course of thorough preparation and high culture. A man may plow, harrow and plant with strawberries the land that was planted the previous year in corn, and probably secure a remunerative return, with little more trouble or cost than was expended on the corn. Or, he may select half the area that was in corn, plow it deeply in October, and if he detects traces of the white grub, cross-plow it again just as the ground is beginning to freeze. Early in the spring he can cover the surface with some fertilizer,—there is nothing better than a rotted compost of muck and barn-yard manure,—at the proportion of forty or fifty horse-loads to the acre. Plow and cross-plow again, and in each instance let the first team be followed by a subsoil or lifting plow, which stirs and loosens the substratum without bringing it to the surface. The half of the field prepared in such a thorough manner will prob-

ably yield three times the amount of fruit that could be gathered from the whole area under ordinary treatment, and if the right varieties are grown, and a good market is within reach, the money received will be in a higher ratio.

The principle of generous and thorough preparation may be carried still further in the garden, and its soil, already rich and mellow, may be covered to the depth of several inches with well-rotted compost or any form of barn-yard manure that is not too coarse and full of heat, and this may be incorporated with the earth by trenching to the depth of two feet. Of this

be certain: the strawberry roots will go as deeply as the soil is prepared for them, and the results in abundant and enormous fruit will be commensurate. English gardeners advise trenching even to the depth of three feet, where the soil permits it. Few soils can be found so deep and rich by nature that they cannot be improved by art; and the question for each to decide is how far the returns will compensate for extra preparation.

Having thus considered the most favorable land in the best condition possible, under ordinary cultivation, I shall now treat of that less suitable until we finally reach a soil too sterile and hopelessly bad to repay cultivation. I will speak first of this same deep, moist loam in its unsubdued condition; that is, in stiff sod, trees or brush-wood. Of course, these must be removed, and, as a rule, the crops on new land—which has been undisturbed by the plow for a number of years, and, perhaps, never robbed of its original fertility—will amply repay for the extra labor of clearing. Especially will this be the case if the brush and rubbish are burned evenly over the surface.

The

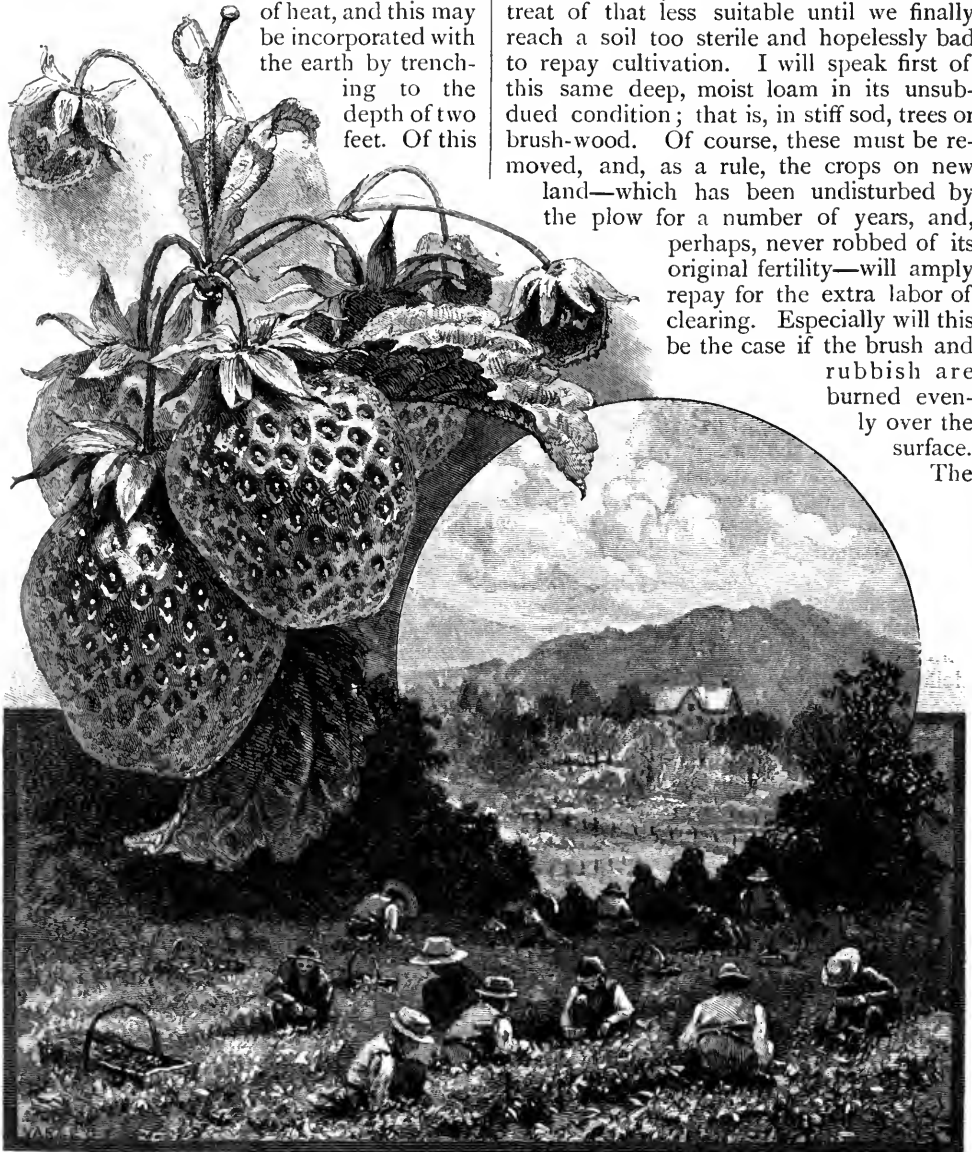

THE "SETH BOYDEN" STRAWBERRY.—THE SCENE OF OPERATIONS.

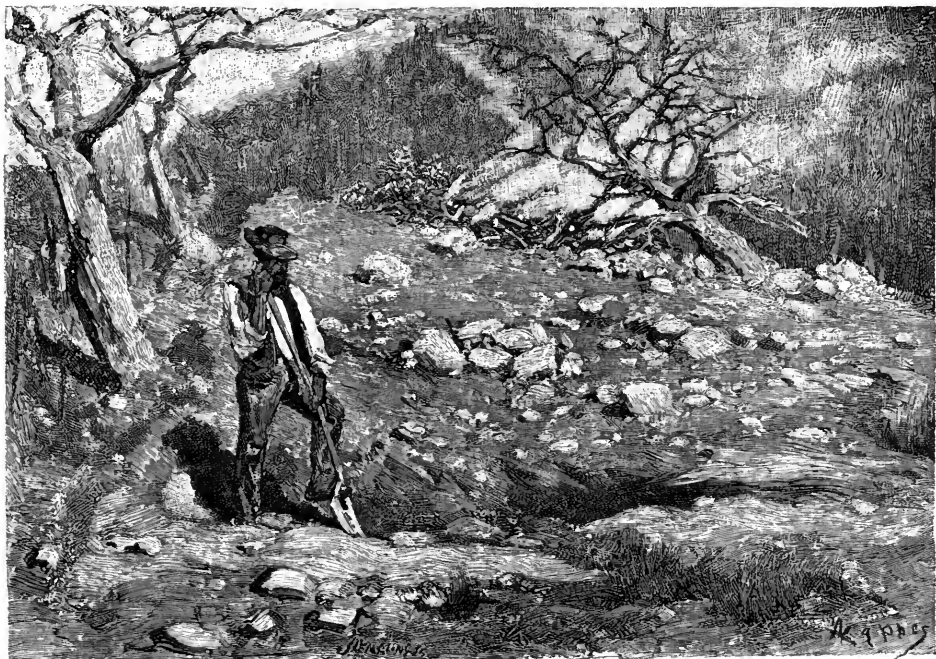

CLEARING LAND FOR STRAWBERRIES.

finest of wild strawberries are found where trees have been felled and the brush burned ; and the successful fruit-grower is the one who makes the best use of such hints from nature. The field would look better and the cultivation be easier if all the stumps could be removed before planting, but this might involve too great preliminary expense, and I always counsel against debt, except in the direst necessity. A little brush burned on each stump will effectually check new growth, and in two or three years these unsightly objects will be so rotten that they can be pried out and easily turned into ashes, one of the best of fertilizers. But where trees or brush have grown very thickly, the roots and stumps must be eradicated. The thick growth on the sandy land of Florida is grubbed out at the cost of about \$30 per acre, and I know of a gentleman who pays at the rate of \$25 per acre in the vicinity of Norfolk, Va. I doubt whether it can be done for less elsewhere.

I have cleaned hedge-rows and stony spots on my place in the following thorough manner: A man commences with pick and shovel on one side of the land and turns it steadily and completely over by hand to the depth of fourteen to eighteen inches, throwing on the surface behind him all the

roots, stumps and stones, and stopping occasionally to blast when the rocks are too large to be pried out. This of course is expensive, and cannot be largely indulged in; but, when accomplished, the work is done for all time, and I have obtained at once by this method some splendid soil, in which the plow sinks to the beam.

As most men handle the pick and shovel, however, the fruit-grower must be chary in his attempts to subdue the earth with these old-time implements. It is too much like making war with the ancient Roman short-sword in an age of rifled guns. I agree with that practical and veteran horticulturist, Peter Henderson, that there are no implements equal to the plow and subsoiler, and in our broad and half-occupied country we should be rather shy of land where these cannot be used.

The cultivator, whose deep, moist loam is covered by sod only, instead of rocks, brush and trees, may feel like congratulating himself on the easy task before him. But let him not be premature in his self-felicitation, for he may find in his sod ground, especially if it be old meadow-land, an obstacle worse than stumps and stones—the *Lachnosteria fusca*. This portentous name may well inspire dread, for the thing itself realizes one's worst fears. The deep, moist

loam is the favorite haunt of this little pest, and he who does not find it lying in wait when turning up land that has been long in sod may deem himself lucky. I mean the "white grub," the larva of the May-beetle that so disturbs our slumbers in early summer by its sonorous hum and aimless bumping against the wall. This white grub, which the farmers often call the "potato worm," is, in this region, the strawberry's most formidable foe, and by devouring the roots, will often destroy acres of the plants. If the plow turns up these ugly customers, the only recourse is to cultivate the land with some other crop until they turn into beetles and fly away. It is said that this pest rarely lays its eggs in plowed land, preferring sod ground, where its larvæ will be protected from the birds, and will find plenty of grass roots on which to feed. Nature sees to it that white grubs are taken care of, but our Monarch strawberries need our best skill and help in their unequal fight, and if *Lachnos* and tribe should turn out in force, Alexander himself would be vanquished.

Excessive moisture will often prevent the immediate cultivation of our ideal strawberry land. Its absence is fatal, its excess equally so.

The construction of drains is essential for three causes. 1st. Land that is dry enough naturally, may lie so as to collect and hold surface water, which, accumulating

It so happened that I found all these conditions on my farm at Cornwall on the Hudson, and perhaps I can treat the subject best by giving the successful methods of coping with the evils.

In front of my house there is a low, level plot of land containing about three acres. Upon this the surface water ran from all sides and there was no outlet. The soil was in consequence sour, and in certain spots only a wiry marsh grass would grow. And yet it required but a glance to see that a drain, which could carry off this surface water immediately, would render it the best land on the place. I tried, in vain, the experiment of digging a deep wide ditch across the entire track, in hopes of finding a porous subsoil. Then I excavated great deep holes, but came to a blue clay that held water like rubber. The porous subsoil in which I knew the region abounded, and which makes Cornwall exceptionally free from all miasmatic troubles, eluded our spades like hidden treasures. I eventually found that I must obtain permission of a neighbor to carry a drain across another farm to the mountain stream that empties into the Hudson at Cornwall Landing. The covered drain through the adjoining place was deep and expensive, but the ditch across my land (marked A on the map) is a small one, walled with stone on either side. It

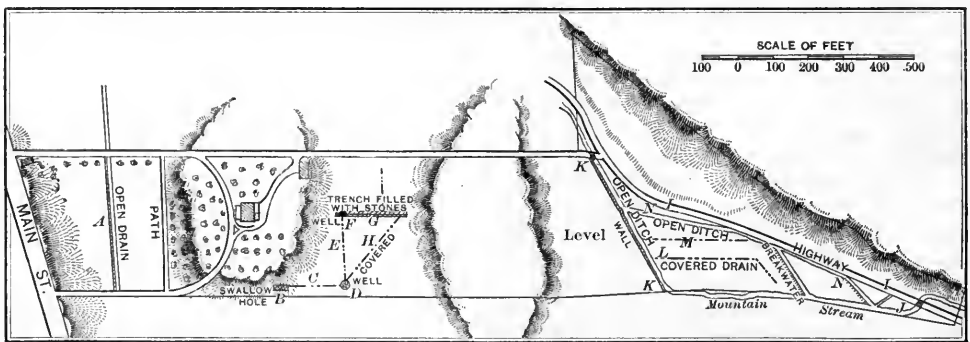

MAP SHOWING EXPERIMENTS IN THE DRAINAGE OF A STRAWBERRY FARM.

with every rain and snow storm, at last renders the soil sour and unproductive. 2d. Comparatively level land, and even steep hill-sides, may be so full of springs as to render drains at short intervals necessary. 3d. Streams, flowing perhaps from distant sources, may find their natural channel across our grounds. If these channels are obstructed or inadequate, we find our land falling into the ways of an old soaker.

answers my purpose, however, giving me as good strawberry land as I could wish. On both sides of this open ditch, and at right angles with it, I had the ground plowed up into beds 130 feet long by 21 wide. The shallow depressions between these beds slope gently toward the ditch, and thus, after every storm, the surface water is at once carried away.

As may be seen from the map, my farm

is peculiar in outline, and resembles an extended city lot, being 2,550 feet long, and only 410 wide.

The house, as shown by the cut on page 240, stands on quite an elevation, in the rear of which the land descends into another swale or basin. The drainage of this presented a still more difficult problem. Not only did the surface water run into it, but in moist seasons the ground was full of springs. The serious feature of the case was that there seemed to be no available outlet in any direction. Unlike the mellow sandy loam in front of the house, the swale in the rear was of the stiffest kind of clay—just the soil to retain and be spoiled by water. During the first year of our residence here, this region was sometimes a pond, sometimes a quagmire, while again, under the summer sun, it baked into earthenware. It was a doubtful question whether this stubborn acre could be subdued, and yet its heavy clay gave me just the diversity of soil I needed. Throughout the high gravelly knoll on which the house stands, the natural drainage is perfect, and a sagacious neighbor suggested that if I cut a ditch across the clayey swale into the gravel of the knoll, the water would find a natural outlet and disappear.

The ditch was dug eight feet wide and five feet deep, for I decided to utilize the surface of the drain as a road-bed. Passing out of the clay and hard pan, we came into the gravel, and it seemed porous enough to carry off a fair-sized stream. I concluded that my difficult problem had found a cheap and easy solution, and to make assurance doubly sure, I directed the men to dig a deep pit and fill it with stones.

When they had gone about nine feet below the surface, I happened to be standing on the brink of the excavation watching the work. A laborer struck his pick into the gravel, when a stream gushed out that in its sudden abundance suggested that which flowed in the wilderness at the stroke of Moses's rod. The problem was now complicated anew. So far from finding an outlet, I had dug a well which the men could scarcely bail out fast enough to permit of its being stoned up. Now something had to be done, and I called in the services of Mr. Caldwell, city surveyor of Newburgh, and to his map I refer the reader for a clearer understanding of my tasks.

Between the upper and lower swales, the ridge on which the house stands slopes to its greatest depression along its western bound-

ary, and I was shown that if I would cut deep enough the open drain in the lower swale could receive and carry off the water from the upper basin. This appeared to be the only resource, but with my limited means it was like a ship-canal across the Isthmus of Panama. The old device of emptying my drains into a hole that practically had no bottom, suggested itself to me. It would be so much easier and cheaper that I resolved once more to try it, though with hopes naturally dampened by my last moist experience. I directed that the hole (marked B on the map) should be oblong and in the direct line of the ditch, so that if it failed of its purpose it could become a part of the drain. Down we went into as perfect sand and gravel as I ever saw, and the deeper we dug the dryer it became. This time, in wounding old "Mother Earth," we did not cut a vein, and there seemed a fair prospect of our creating a new one, for into this receptacle I decided to turn my largest drain and all the water that the stubborn acre persisted in keeping.

I therefore had a "box-drain" constructed along the western boundary of the place (marked C) until it reached the lowest point in the upper swale. This drain was simply and rapidly constructed in the following manner: a ditch was first dug sufficiently deep and wide and with a fall that carried off the water rapidly. In the bottom of this ditch the men built two roughly faced walls, one foot high and eight inches apart. Comparatively long, flat stones that would reach from wall to wall were easily found, and thus we had a covered water-course, eight inches by a foot, forming the common box-drain that will usually last a life-time. The openings over the channel were carefully "chinked" in with small stones and all covered with inverted sods, shavings, leaves or anything that prevented the loose soil from sifting or washing down into the water-course.

At the upper end of the box-drain, just described, a second and smaller receptacle was dug (marked D), and from this was constructed another box-drain (E), six inches square, across the low ground to the end of the canal in which we had found the well (F). This would not only drain a portion of the land but would also empty the big ditch (G) and prevent the water of the well from rising above a certain point. This kind of stone-work can be done rapidly: two men in two short winter days built

thirteen rods with a water-course six inches in the clear.

To the upper and further end of the canal (G), I constructed another and cheaper style of drain. In the bottom of this ditch (H), two stones were placed on their ends or edges and leaned together so as to form a kind of arch, and then other stones were thrown over and around them until they reached a point eighteen inches from the surface. Over these stones, as over the box-drains also, was placed a covering of any coarse litter to keep the earth from washing down; and then the construction of one or two short side-drains, the refilling the ditches and leveling the ground completed my task.

It will be remembered that this entire system of drainage ended in the excavation (B) already described. The question was now whether such a theory of drainage would "hold water." If it would, the hole I had dug must not, and I waited to see. It promised well. Quite a steady stream poured into it and disappeared. By and by there came a heavy March storm. When I went out in the morning everything was afloat. The big canal and the well at its lower end were full to overflowing. The stubborn acre was a quagmire, and alas! the excavation which I had hoped would save so much trouble and expense was also full. I plodded back under my umbrella with a brow as lowering as the sky. There seemed nothing for it but to cut a Dutch gap that would make a like chasm in my bank account. By noon it cleared off and I went down to take a melancholy survey of the huge amount of work that now seemed necessary, when, to my great joy, the oblong cut, in which so many hopes had seemingly been swamped, was entirely empty. From the box-drain a large stream poured into it and went down—to China, for all that I knew. I went in haste to the big canal and found it empty, and the well lowered to the mouth of the drain. The stubborn acre was now under my thumb and I have kept it there ever since. During the past summer, I had upon its wettest and stiffest portion two beds of *Jucunda* strawberries that yielded at the rate of one hundred and ninety bushels to the acre. The *Jucunda* strawberry is especially adapted to heavy land requiring drainage, and I think an enterprising man in the vicinity of New York might so unite them as to make a fortune. The hole was filled with stone and now forms a part

of my garden, and the canal answers for a road-bed as at first intended. In the fortuitous well, I have placed a force-pump, around which are grown and watered my potted plants. The theory of carrying drains into gravel does hold water, and sometimes holes can be dug at a slight expense, that practically have no bottom.

In the rear of my place there was a third drainage problem very different from either of the other two. My farm runs back to the rise of the mountain, whose edge it skirts for some distance. It thus receives at times much surface water. At the foot of the mountain slope, there are two or three acres of low alluvial soil that was formerly chiefly covered with the coarse useless herbage of the swamp. Between the meadow and the slope of the mountain, "the town" built a "boulevard" (marked I I on the map), practically "cribbing" an acre or two of land. At the extreme end of the farm, and just beyond the alluvial ground, was the channel of a brook (marked J). Its strong bed, through which trickled a rill, had a very innocent aspect on the October day when we looked the farm over and decided upon its purchase. The rill ran a little way on my grounds, then crept under the fence and skirted my western boundary for several hundred yards. On reaching a rise of a land, it re-entered my place and ran obliquely across it. It thus inclosed three sides of the low, bushy meadow I have named. In a vague way I felt that eventually something would have to be done to direct this little child of the mountain into proper ways, and to subdue the spirit of the wilderness that it diffused on every side. I had its lower channel across the place (K K) cleared out, thinking that this might answer for the present; and the gurgle of the little streamlet along the bottom of the ditch seemed a low laugh at the idea of its ever filling the three square feet of space above it. Deceitful little brook! Its innocent babble contained no suggestion of its hoarse roar, as on a March day, the following spring, it tore its way along, scooping the stones and gravel from its upper bed and scattering them far and wide over the alluvial meadow. Instead of a tiny rill, I found that I would have to cope at times with a mountain torrent. At first the task was too heavy, and the fitful-tempered brook, and the swamp-like regions it encompassed, were left for years to their old wild instincts. At last the increasing demands of my business made it more neces-

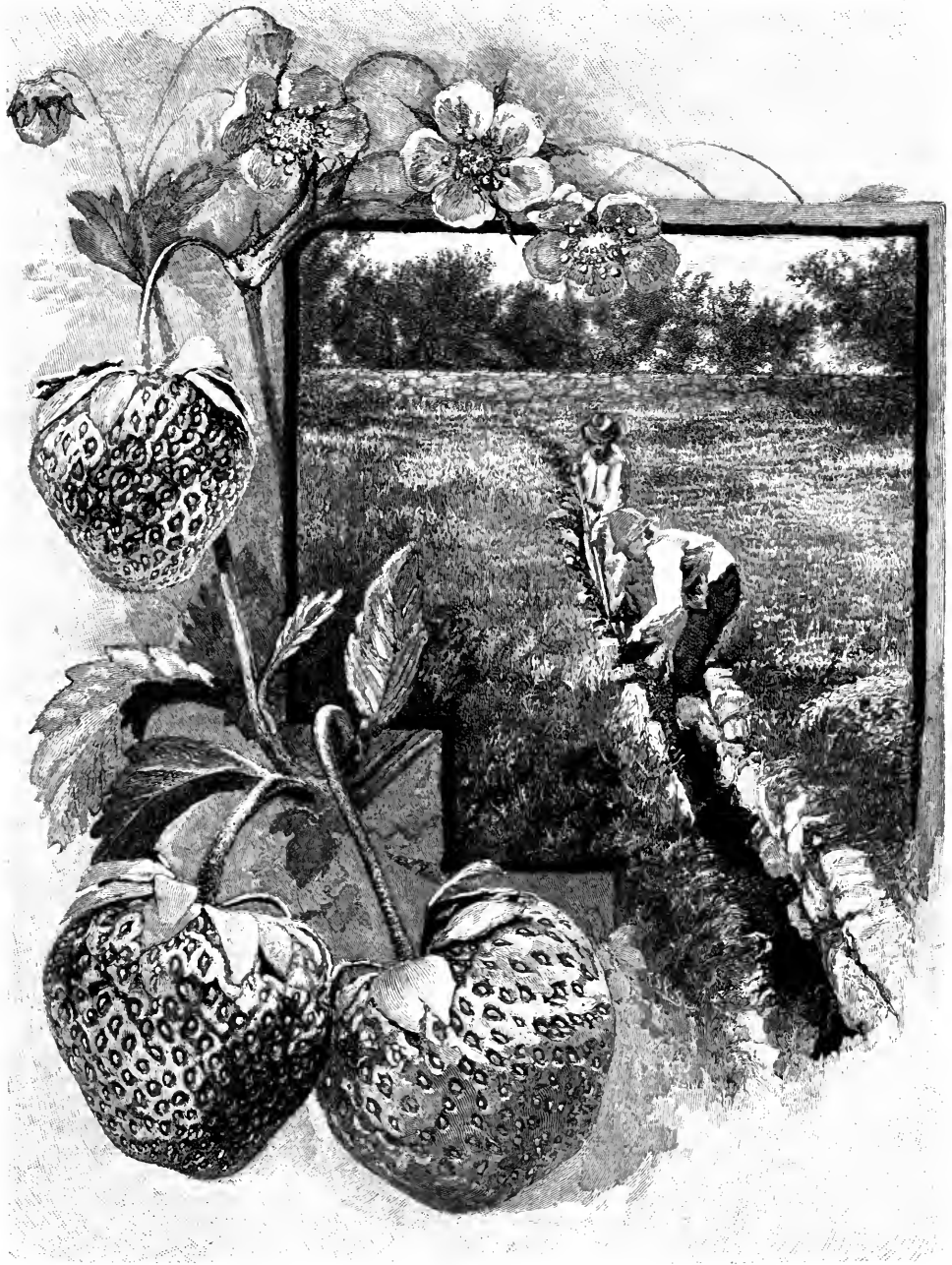

MEN DITCHING—JUCUNDA STRAWBERRY.

sary to have arable land, and I saw that, if I could keep it from being overwhelmed with water and gravel, the alluvial meadow was just the place for strawberries.

I commenced at the lowest point where it finally leaves my grounds and dug a canal

(K K) twelve feet wide and four or five feet deep across my place, stoning up its walls on either side. An immense amount of earth and gravel was thrown on the lower side so as to form a high, strong embankment in addition to the channel. Then,

where it entered the farm above the meadow, I had a wide, deep ditch excavated, throwing all the *débris* between it and the land I wished to shield. Throughout the low meadow, two covered box-drains (L and M) were constructed so that the plow could pass over them. On the side of the meadow next to the boulevard and mountain, I had an open drain (N N) dug and filled with stones even with the ground. It was designed to catch and carry off the surplus water merely from the long extent of mountain slope that it skirted. The system of ditches to protect and drain the partial swamp, and also to manage the deceitful brook, was now finished, and I waited for the results. During much of the summer there was not a drop of water in the wide canal, save where a living spring trickled into it. The ordinary fall rains could scarcely more than cover the broad, pebbly bottom, and the unsophisticated laughed and said that I reminded them of the general who trained a forty-pound gun on a belligerent mouse. I remembered what I had seen and bided my time.

But I did not have to wait till March. One November day it began to rain,—and it kept on. All the following night there was a steady rush and roar of falling water. It was no ordinary pattering, but a gusty outpouring from the “windows of heaven.” The two swales in the front and the rear of the house became great muddy ponds, tawny as the “yellow Tiber,” and through intervals of the storm came the sullen roar of the little brook that had been purring like a kitten all summer. Toward 'night Nature grew breathless and exhausted; there were sobbing gusts of wind and sudden gushes of rain that grew less and less frequent. It was evident she would become quiet in the night and quite serene after her long tempestuous mood. As the sun was setting I ventured out with much misgiving. The deepening roar as I went down the lane increased my fears, but I was fairly appalled by the wild torrent that cut off all approach to the bridge. The water had not only filled the wide canal, but also at a point a little above the bridge, had broken over and washed away the high embankment. I skirted along the tide until I reached the part of the bank that still remained intact, and there beneath my feet rushed a flood that would have instantly swept away horse and rider. Indeed, quite a large tree had been torn up by its roots and carried down until it caught in the

bridge, which would also have gone had not the embankment above it given way.

The lower part of the meadows was also under water. It had been plowed, and therefore would wash readily. Would any soil be left? A few moments of calm reflection, however, removed my fears. The treacherous brook had not beguiled me during the summer into inadequate provision for this unprecedented outbreak. I saw that my deep, wide cut had kept the flood wholly from the upper part of the meadow which contained a very valuable bed of high-priced Sharpless strawberry-plants, and that the slowly moving tide which covered the lower part was little more than back-water and overflow. The wide ditches were carrying off swiftly and harmlessly the great volume that, had not such channels been provided, would have made my rich alluvial meadow little else than a stony, gravelly waste. The embankment had given way at a point too low down to permit much damage.

My three diverse systems of drainage had thus practically stood the severest test, perhaps, that will ever be put upon them, and my grounds had not been damaged to any extent worth naming. The cost had been large, but the injury caused by that one storm would have amounted to a larger sum had there been no other channels for the water than those provided by nature.

My readers will find, in many instances, that they have land which must be or may be drained. If it can be done sufficiently, the very ideal strawberry soil may be secured, moist and deep, but not wet.

In cases, however, when the fall is slight, say scarcely one foot in a hundred, it would be well to employ the services of a surveyor, and thus secure the proper grades. If stones are not convenient, tile can be bought at moderate prices; and if the task is at all extensive, the reader should not only consult a work like that by Col. George E. Waring, but also talk with practical men in the neighborhood who have grappled with like problems successfully. The common sense and experience indigenous to a locality is invaluable, and men often fail as well as succeed by being wiser than their neighbors.

We have now reached a point at which we must consider land which in its essential character is unfavorable to strawberries, and yet which may be the best to be had. The difficulties here are not merely accidental or remediable, such as lack of depth

or fertility, the presence of stones or stumps, undue wetness of the soil, etc. Any or all of these obstacles may be found, but, in addition, there are evils inseparable from the soil, and which cannot be wholly eradicated. The best we can hope in such a case is to make up by art what is lacking in nature.

This divergence from the deep, moist sandy loam, the ideal strawberry land, is usually toward a stiff, cold, stubborn clay, or toward a drougthy, leachy sand that retains neither fertility nor moisture. Of course these opposite soils require different treatment.

We will consider first the less objectionable, *i. e.*, the heavy clay. To call clay more favorable for strawberries than sandy land may seem like heresy to many, for it is a popular impression that light soils are the best. Experience and observation have, however, convinced me of the contrary. With the clay you have a stable foundation. Your progress may be slow but it can be made sure. The character of a sandy foundation was taught centuries ago. Moreover, all the fine foreign-blooded varieties grow far better on heavy land, and a soil largely mixed with clay gives a wider range in the choice of varieties.

If I had my choice between a farm of cold stiff clay or light leachy sand, I would unhesitatingly take the former, and I would overcome its native unfitnes by the following methods: If at all inclined to be wet, as would be natural from its tenacious texture, I should first drain it thoroughly. Then if I found a fair amount of vegetable matter, I would give it a dressing of air-slacked lime, and plow it deeply late in the

fall, leaving it unharrowed so as to expose as much of the soil as possible to the action of the frost. Early in the spring, as soon as the ground was dry enough to work and all danger of frost was over, I would harrow in buckwheat and plow it under as it came into blossom; then sow a second crop and plow that under also. It is the characteristic of buckwheat to lighten and clean land, and the reader perceives that it should be our constant aim to impart lightness and life to the heavy soils. Lime, in addition to its fertilizing effects, acts chemically on the ground, producing the desired effect. It may be objected that lime is not good for strawberries. That is true if the lime is applied directly to the plants, as we would ashes or bone dust, but when it is mixed with the soil for months it is so neutralized as to be helpful, and in the meantime its action on the soil itself is of great value. It must be used for strawberries, however, in very limited quantities. The coarse green straw of the buckwheat is useful by its mechanical division of the heavy land, while at the same time its decomposition fills the soil with ammonia and other gases vitally necessary to the plant. A clay soil retains these gases with little waste. It is thus capable of being enriched to almost any extent, and can be made a store-house of wealth.

Where it can be procured, there is no better fertilizer for clay land than the product of the horse stable, which as a rule can be plowed under in its raw, unfermented state, its heat and action in decay producing the best results. Of course judgment and moderation must be employed. The root of a young-growing plant cannot feed

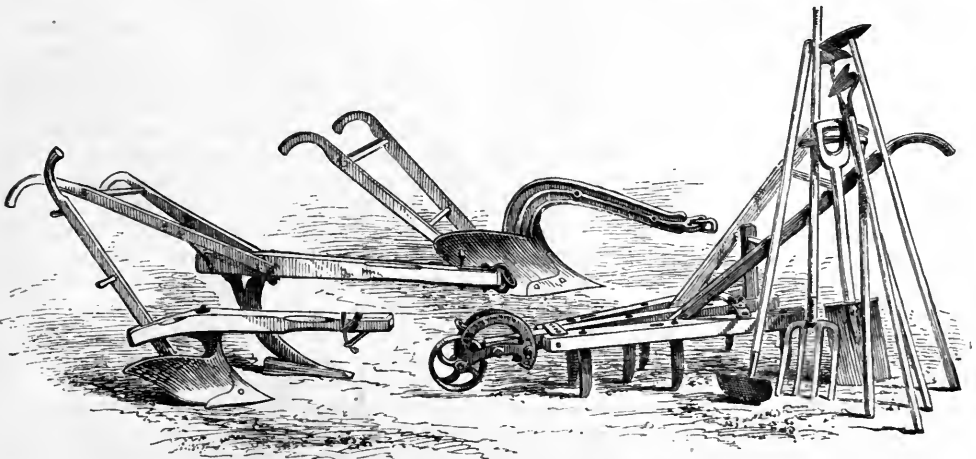

TOOLS FOR A STRAWBERRY FARM.

in a mass of fermenting manure, no matter what the soil may be. The point I wish to make is that cold heavy land is greatly benefited by having these heating, gas-producing processes take place beneath its surface. After they are over, the tall rank foliage and enormous fruit of the Jucunda strawberry (a variety that can scarcely grow at all in sand) will show the capabilities of clay.

While buckwheat is a good green crop to plow under, if the cultivator can wait for the more slowly maturing red-top clover he will find it far better, both to enrich and to lighten up his heavy soil; for it is justly regarded as the best means of imparting the mellowness and friability in which the roots of strawberries as well as all other plants luxuriate. There are no doubt soils fit for bricks and piping only, but in most instances by a judicious use of the means suggested, they can be made to produce heavy and long-continued crops of the largest fruit.

These same principles apply to the small garden plot as well as to the acre. Instead of carting off weeds, old pea-vines, etc., dig them under evenly over the entire space when possible. Enrich with warm, light fertilizers, and if a good heavy coat of hot strawy manure, is trenched in the heaviest stickiest clay in October or November, strawberries or anything else can be planted the following spring. The gardener who thus expends a little thought and far-sighted labor will at last secure results that will surpass his most sanguine hopes, and that, too, from land that would otherwise be as hard as Pharaoh's heart.

Before passing from this soil to that of an opposite character, let me add a few words of caution. Clay land should never be stirred when either very wet or very dry, or else a lumpy condition results that injures it for years. It should be plowed or dug only when it crumbles. When the soil is sticky or turns up in great hard lumps, let it alone. The more haste the worst speed.

Again, the practice of fall plowing, so very beneficial in latitudes where frosts are severe and long continued, is just the reverse in the far South. There our snow is rain, and the upturned furrows are washed down into a smooth sticky mass by the winter storms. On steep hill-sides, much of the soil would ooze away with every rain, or slide down hill *en masse*. In the South, therefore, unless a clay soil is to be planted at once, it must not be disturbed in the fall,

and it is well if it can be protected by stubble or litter, which shields it from the direct contact of the rain and from the sun's rays. But cow-peas, or any other rank-growing green crop, is as useful to Southern clay as to Northern, and Southern fields might be enriched rapidly since their long season permits of plowing under several growths.

Suppose that, in contrast, our soil is a light sand. In this case, the question of cultivat-



COUNTING AND MAILING PLANTS.

ing strawberry plants is greatly simplified, but the problem of obtaining a heavy crop is correspondingly difficult. The plow and the cultivator run readily enough, and much less labor is required to keep the weeds in subjection, but, as a rule, light land yields little fruit, and yet under favoring circumstances I have seen magnificent crops of certain varieties growing on sand. If sufficient moisture and fertility can be maintained, many of our best varieties will thrive and produce abundantly, but to do this is the very pith of our difficulty. Too often a sandy soil will not retain moisture and manure. Such light land is generally very deficient in vegetable matter and, therefore, whenever it is possible I would turn under green crops. If the soil could be made sufficiently fertile to produce a heavy crop of clover and this were plowed under in June, and then buckwheat harrowed in and its rank growth turned under in August, strawberries could be planted at once with excellent prospects of fine crops

for the two succeeding years. Did I propose to keep the land in strawberries, I would then give it another year of clover and buck-wheat. The green crop, when decayed, is lighter than clay, and renders its tenacious texture more friable and porous; it also benefits the sandy soil by supplying the absent humus, or vegetable mold, which is essential to all plant life. This mold is also cool and humid in nature, and aids in retaining moisture.

With the exception of the constant effort to place green vegetable matter under the surface, my treatment of sandy ground would be the reverse of that described for clay. Before using the product of the horse-stable, I would compost it with at least an equal bulk of leaves, muck, sods, or even plain earth, if nothing better could be found. A compost of stable manure with clay would be most excellent. If possible, I would not use any manure on light ground until all fermentation was over, and then I would rather harrow than plow it in. This will leave it near the surface, and the rains will leach it down to the roots—and below them, also—only too soon. Fertility cannot be stored up in sand as in clay, and it should be our aim to give our strawberries the food they need in a form that permits of its immediate use. Therefore, in preparing such land, I would advise deep plowing just before planting, and, if possible, just after a rain; then the harrowing in of a liberal top-dressing of rotted compost, or of muck sweetened by the action of frost and the fermentation of manure, or, best of all, the product of the cow-stable. Decayed leaves, sods and wood ashes, also make excellent fertilizers.

In the garden, light soils can be given a much more stable and productive character by covering them with clay to the depth of one or two inches every fall. The winter's frost and rains mix the two diverse soils, to their mutual benefit. Carting sand on clay is rarely remunerative; the reverse is decidedly so, and top-dressings of clay on light land are often more beneficial than equal amounts of manure.

As practically employed, I regard quick, stimulating manures, like guano, very injurious to light soils. I believe them to be the curse of the South. They are used "to make a crop," as it is termed; and they do make it for a few years, but to the utter impoverishment of the land.

And yet, by the aid of these stimulating commercial fertilizers, the poorest and thinnest soil can be made to produce fine straw-

berries, if sufficient moisture can be maintained. Just as a physician can rally an exhausted man to a condition in which he can take and be strengthened by food, so land, too poor and light to sprout a pea, can be stimulated into producing a meager green crop of some kind, which, plowed under, will enable the land to produce a second and heavier burden. This, in turn placed in the soil, will begin to give a suggestion of fertility. Thus poor or exhausted soil can be made, by several years of skillful management, to convalesce slowly into strength.

Coarse, gravelly soils are usually even worse. If we must grow our strawberries on them, give the same general treatment that I have just suggested.

On some peat soils the strawberry thrives abundantly; on others it burns and dwindles. With such a soil, I should experiment with bone-dust, ashes, etc., until I found just what was lacking.

No written directions can take the place of common sense, judgment, and, above all, experience. Soils vary like individual character. I have yet to learn of a system of rules that will teach us how to deal with every man we meet. It is ever wise, however, to deal justly and liberally. He that expects much from his land must give it much.

I have dwelt at length on the preparation and enrichment of the land, since it is the corner-stone of all subsequent success. Let me close by emphasizing again the principle which was made prominent at first. Though we give our strawberry plants everything else they need, our crop of fruit will still be good or bad in proportion as we are able to maintain abundant moisture during the blossoming and fruiting season. If provision can be made for irrigation, it may increase the yield tenfold.

SECURING OUR PLANTS.

HAVING prepared and enriched our ground, we are ready for the plants. The kinds and quantities we desire are often not to be found in our vicinity. In private gardens, moreover, even if our neighbors are liberal and have the plants to spare, names and varieties are usually in a tangle. We must go to the nurseryman. At this point, perhaps, a brief appeal to the reader's common sense may save much subsequent loss and disappointment.

In most of our purchases, we see the article before we take it, and can estimate its

value. Just the reverse is usually true of plants. We know—or believe—that certain varieties are valuable, and we order them from a distance, paying in advance. When received, the most experienced cannot be sure that the plants are true to the names they bear. We must plant them in our carefully prepared land, expend upon them money, labor, and, above all, months and years of our brief lives, only to learn, perhaps, that the varieties are not what we ordered, and that we have wasted everything on a worthless kind. The importance of starting right, therefore, can scarcely be overestimated. It is always best to buy of men who, in the main, grow their own stock, and therefore know about it, and who have established a reputation for integrity and accuracy. The itinerant agent flits from Maine to California, and too often the marvelous portraits of fruits that he exhibits do not even resemble the varieties whose names they bear. It is best to buy of those who have a "local habitation and a name," and then, if anything is wrong, one knows where to look for redress.

Even if one wishes to be accurate, it is difficult to know that one's stock is absolutely pure and true to name. The evil of mixed plants is more often perpetuated in the following innocent manner than by any intentional deception: For instance, one buys from a trustworthy source, as he supposes, a thousand "Monarch" strawberry plants, and sets them out in the spring. All blossoms should be picked off the first year, and, therefore, there can be no fruit as a test of purity that season. But by fall there are many thousands of young plants. The grower naturally says: "I bought these for Monarch, therefore they are Monarch," and he sells many plants as such. When coming into fruit the second summer, he finds, however, that not one in twenty is a Monarch plant. As an honest man he now digs them under in disgust; but the mischief has already been done, and scattered throughout the country are thousands of mixed plants which multiply with the vigor of evil. Nurserymen should never take varieties for granted, no matter where obtained. I endeavor to so train my eye that I can detect the distinguishing marks even in the foliage and blossoms, and if anything looks suspicious I root it out.

If possible, the nurseryman should start

with plants that he knows to be genuine, and propagate from them. Then by constant and personal vigilance he can maintain a stock that will not be productive chiefly of profanity when coming into fruit.

It is not thrift to save in the first cost of plants, if thereby the risk of obtaining poor, mixed varieties is increased. I do not care to save five dollars to-day and lose fifty by the operation within a year. A gentleman wrote to me: "I have been outrageously cheated in buying plants." On the same page he asked me to furnish stock at rates as absurdly low as those of the man who cheated him. If one insists on having an article at far less than the cost of production, it is not strange that he finds some who will "cheat him outrageously." I find it by far the cheapest in the long run to go to the most trustworthy sources and pay the grower a price which enables him to give me just what I want.

When plants are both fine and genuine they can still be spoiled, or, at least, injured in transit from the ground where they grew. Dig so as to save all the roots, shake these clean of earth, straighten them out, and tie the plants into bundles of fifty. Pack in boxes, with the roots down in moss and the tops exposed to the air. Do not press them in too tightly or make them too wet, or else the plants become heated—a process which speedily robs them of all vitality. In cool seasons, and when the distance is not too great, plants can be shipped in barrels thickly perforated with holes. The tops should be toward the sides and the roots in the center, down through which there should be a circulation of air. In every case envelop the roots in damp moss or leaves—damp, but not wet. Plants can be sent by mail at the rate of one cent per ounce. Those sent out in this way rarely fail in doing well.

The greater part of the counting and packing of plants should be done in a cellar, in order to prevent the little fibrous roots, on which the future growth so greatly depends, from becoming shriveled. The best part of the roots are extremely sensitive to sunlight or frost, and, worse than all, to a cold, dry wind. Therefore, have the plants gathered up as fast as they are dug and carried to a damp, cool place where the temperature varies but little. From such a place they can be packed and shipped with the leisure that insures careful work.

THE GRANDISSIMES.*

A STORY OF CREOLE LIFE.

By GEORGE W. CABLE, author of "Old Creole Days."

CHAPTER VII.

WAS IT HONORÉ GRANDISSIME ?

A CREOLE gentleman, on horseback one morning with some practical object in view,—drainage, possibly,—had got what he sought,—the evidence of his own eyes on certain points,—and now moved quietly across some old fields toward the town, where more absorbing interests awaited him in the Rue Toulouse; for this Creole gentleman was a merchant, and because he would presently find himself among the appointments and restraints of the counting-room, he heartily gave himself up, for the moment, to the surrounding influences of nature.

It was late in November; but the air was mild and the grass and foliage green and dewy. Wild flowers bloomed plentifully and in all directions; the bushes were hung, and often covered, with vines of sprightly green, sprinkled thickly with smart-looking little worthless berries, whose sparkling complacency the combined contempt of man, beast, and bird could not dim. The call of the field-lark came continually out of the grass, where now and then could be seen his yellow breast; the orchard oriole was executing his fantasias in every tree; coveys of partridges ran across the path close under the horse's feet, and stopped to look back almost within reach of the riding-whip; clouds of rice-birds, in their odd, irresolute way, rose from the high bulrushes and settled again, without discernible cause; little wandering companies of sparrows undulated from hedge to hedge; a great rabbit-hawk sat alone in the top of a lofty pecan-tree; that petted rowdy, the mocking-bird, dropped down into the path to offer fight to the horse, and, failing in that, flew up again and drove a crow into ignominious retirement beyond the plain; from a place of flags and reeds a white crane shot upward, turned, and then, with the slow and stately beat peculiar to her wing, sped away until, against the tallest cypress of the distant forest, she became a tiny white speck on its black, and suddenly disappeared, like one flake of snow.

The scene was altogether such as to fill

any hearty soul with impulses of genial friendliness and gentle candor; such a scene as will sometimes prepare a man of the world, upon the least direct incentive, to throw open the windows of his private thought with a freedom which the atmosphere of no counting-room or drawing-room tends to induce.

The young merchant—he was young—felt this. Moreover, the matter of business which had brought him out had responded to his inquiring eye with a somewhat golden radiance, and your true man of business—he who has reached that elevated pitch of serene, good-natured reserve which is of the high art of his calling—is never so generous with his pennyworths of thought as when newly in possession of some little secret worth many pounds.

By and by the behavior of the horse indicated the near presence of a stranger; and the next moment the rider drew rein under an immense live-oak where there was a bit of paling about some graves, and raised his hat.

"Good-mawning, seh." But for the silent r's, his pronunciation was exact, yet evidently an acquired one. While he spoke his salutation in English, he was thinking in French: "Without doubt, this rather oversized, bare-headed, interrupted-looking convalescent who stands before me, wondering how I should know in what language to address him, is Joseph Frowenfeld, of whom Doctor Keene has had so much to say to me. A good face—unsophisticated, but intelligent, mettlesome and honest. He will make his mark; it will probably be a white one; I will subscribe to the adventure."

"You will excuse me, seh?" he asked after a pause, dismounting, and noticing, as he did so, that Frowenfeld's knees showed recent contact with the turf; "I have, myself, some interhest in two of these ghraves, seh, as I suppose—you will pahdon my ffreedom—you have in the otheh fo'."

He approached the old but newly whitened paling, which encircled the tree's trunk as well as the six graves about it. There was in his face and manner a sort of impersonal human kindness, well calculated

to engage a diffident and sensitive stranger, standing in dread of gratuitous benevolence or pity.

"Yes, sir," said the convalescent, and ceased; but the other leaned against the palings in an attitude of attention, and he felt induced to add: "I have buried here my father, mother and two sisters,"—he had expected to continue in an unemotional tone; but a deep respiration usurped the place of speech. He stooped quickly to pick up his hat, and, as he rose again and looked into his listener's face, the respectful, unobtrusive sympathy there expressed went directly to his heart.

"Victims of the feveh," said the Creole, with gentle gravity. "How did that happen?"

As Frowenfeld, after a moment's hesitation, began to speak, the stranger let go the bridle of his horse and sat down upon the turf. Joseph appreciated the courtesy and sat down, too; and thus the ice was broken.

The immigrant told his story; he was young—often younger than his years—and his listener several years his senior; but the Creole, true to his blood, was able at any time to make himself as young as need be, and possessed the rare magic of drawing one's confidence without seeming to do more than merely pay attention. It followed that the story was told in full detail, including grateful acknowledgment of the goodness of an unknown friend, who had granted this burial-place on condition that he should not be sought out for the purpose of thanking him.

So a considerable time passed by, in which acquaintance grew with delightful rapidity.

"What will you do now?" asked the stranger, when a short silence had followed the conclusion of the story.

"I hardly know. I am taken somewhat by surprise. I have not chosen a definite course in life—as yet. I have been a general student, but have not prepared myself for any profession; I am not sure what I shall be."

A certain energy in the immigrant's face half redeemed this child-like speech. Yet the Creole's lips, as he opened them to reply, betrayed amusement; so he hastened to say:

"I appreciate yo' position, Mr. Frowenfeld,—excuse me, I believe you said that was yo' fatha's name. And yet,"—the shadow of the amused smile lurked another instant about a corner of his mouth,—"if

you would unde'stand me kindly I would say, take ca'e"——

What little blood the convalescent had rushed violently to his face, and the Creole added:

"I do not insinuate you would willingly be idle. I think I know what you want. You want to make up yo' mind *now* what you will *do*, and at yo' leisu'e what you will *be*; eh? To be, it seems to me," he said in summing up,—"to be is not so necessary as to do, eh? or-h am I wrhong?"

"No, sir," replied Joseph, still red. "I was feeling that just now. I will do the first thing that offers; I can dig."

The Creole shrugged and pouted.

"And be called a *dos brhillee*—a 'burnt-back.'"

"But"——began the immigrant, with overmuch warmth.

The other interrupted him, shaking his head slowly, and smiling as he spoke.

"Mr. Frowenfeld, it is of no use to talk; you may hold in contempt the Creole sco'n of toil—just as I do, myself, but in theory, my de'-seh, not too much in practice. You cannot affo'd to be *entirely* different to the community in which you live; is that not so?"

"A friend of mine," said Frowenfeld, "has told me I must 'compromise.'"

"You must get acclimated," responded the Creole; "not in body only, that you have done; but in mind—in taste—in conversation—and in convictions too, yes, ha, ha! They all do it—all who come. They hold out a little while—a verhy little; then they open thei' sto'es on Sunday, they impo't cahgoes of Afrhicans, they bribe the officials, they smuggle goods, they have colo'd housekeepe's. My-de'-seh, the wata must expect to take the shape of the bucket; eh?"

"One need not be water!" said the immigrant.

"Ah!" said the Creole, with another amiable shrug, and a wave of his hand; "certainly you do not suppose that is my advice—that those things have my approval."

Must we repeat already that Frowenfeld was abnormally young?

"Why have they not your condemnation?" cried he with an earnestness that made the Creole's horse drop the grass from his teeth and wheel half around.

The answer came slowly and gently.

"Mr. Frowenfeld, my habit is to buy cheap and sell at a prhofit. My condemnation? My-de'-seh, there-h is no sa-a-ale

for-hit ! it spoils the sale of othel goods, my-de'-seh. It is not to condemn that you want; you want to suc-ceed. Ha, ha, ha ! you see I am a mehchant, eh ? My-de'-seh, can you affo'd not to succeed ? ”

The speaker had grown very much in earnest in the course of these few words, and as he asked the closing question, arose, arranged his horse's bridle and with his elbow in the saddle, leaned his handsome head on his equally beautiful hand. His whole appearance was a dazzling contradiction of the notion that a Creole is a person of mixed blood.

“ I think I can ! ” replied the convalescent, with much spirit, rising with more haste than was good, and staggering a moment.

The horseman laughed outright.

“ Yo' principle is the best, I cannot dispute that ; but whethel you can act it out—rhefo'me's do not make money, you know.” He examined his saddle-girth and began to tighten it. “ One can condemn—too cautiously—by a kind of—elevated cowa'dice (I have that fault) ; but one can also condemn too rashly ; I rhemembel when I did so. One of the occupants of those two grhaves you see yondeh side by side—I think might have lived longer-h if I had no spoken so rashly for-h 'is rhights. Did you evva hear-h of Brhas-Coupé, Mr. Frhownfeld ? ”

“ I have heard only the name.”

“ Ah ! Mr. Frhownfeld, *there* was a bold man's chance to denounce wrhng and opprhession ! Why, that negrho's death changed the whole channel of my convictions.”

The speaker had turned and thrown up his arm with frowning earnestness ; he dropped it and smiled at himself.

“ Do not mistake me for one of yo' new-fashioned Philadelphia '*negrhophiles*' ; I am a mehchant, my-de'-seh, a good subject of His Catholic Majesty, a Crheole of the Crheoles, and so fo'th, and so fo'th. Come ! ”

He slapped the saddle.

To have seen and heard them a little later as they moved toward the city, the Creole walking before the horse and Frowenfeld sitting in the saddle, you might have supposed them old acquaintances. Yet the immigrant was wondering who his companion might be. He had not introduced himself—seemed to think that even an immigrant might know his name without asking. Was it Honoré Grandissime ? Joseph

was tempted to guess so ; but the inscription on the silver-mounted pommel of the fine old Spanish saddle was *J. M.*

The stranger talked freely. The sun's rays seemed to set all the sweetness in him a-working, and his pleasant worldly wisdom foamed up and out like fermenting honey.

By and by the way led through a broad, grassy lane where the path turned alternately to right and left among some wild acacias. The Creole waved his hand toward one of them and said :

“ Now, Mr. Frhownfeld, you see ? one man walks where-h 'e sees anothe's thrack ; that is what makes a path ; but you want a man, instead of passing arhound this prhickly bush, to lay hold of it with his naked hands and pull it up by the rhoots.”

“ But a man armed with the truth is far from being bare-handed,” replied the convalescent, and they went on, more and more interested at every step,—one in this very raw imported material for an excellent man, the other in so striking an exponent of a unique land and people.

They came at length to the crossing of two streets, and the Creole, pausing in his speech, laid his hand upon the bridle.

Frowenfeld dismounted.

“ Do we paht yeh ? ” asked the Creole. “ Well, Mr. Frhownfeld, I hope to meet you soon again.”

“ Indeed, I thank you, sir,” said Joseph, “ and I hope we shall, although — ”

The Creole paused with a foot in the stirrup and interrupted him with a playful gesture ; then as the horse stirred, he mounted and drew in the rein.

“ I know ; you want to say you cannot accept my philosophy and I cannot appreciate yo's ; but I appreciate it mo' than you think, my-de'-seh.”

The convalescent's smile showed much fatigue.

The Creole extended his hand ; the immigrant seized it, wished to ask his name, but did not ; and the next moment he was gone.

The convalescent walked meditatively toward his quarters, with a faint feeling of having been found asleep on duty, and awakened by a passing stranger. It was an unpleasant feeling, and he caught himself more than once shaking his head. He stopped, at length, and looked back ; but the Creole was long since out of sight. The mortified self-accuser little knew how very similar a feeling that vanished person was carrying away with him. He turned

and resumed his walk, wondering who Monsieur J. M. might be, and a little impatient with himself that he had not asked.

"It is Honoré Grandissime; it must be he!" he said.

Yet see how soon he felt obliged to change his mind.

CHAPTER VIII.

SIGNED—HONORÉ GRANDISSIME.

ON the afternoon of the same day, having decided what he would "do," he started out in search of new quarters. He found nothing then, but next morning came upon a small, single-story building in the rue Royale,—corner of Conti,—which he thought would suit his plans. There were a door and show-window in the rue Royale, two doors in the intersecting street, and a small apartment in the rear which would answer for sleeping, eating, and studying purposes, and which connected with the front apartment by a door in the left-hand corner. This connection he would partially conceal by a prescription-desk. A counter would run lengthwise toward the rue Royale, along the wall opposite the side-doors. Such was the spot that soon became known as "Frowenfeld's Corner."

The notice "À Louer" directed him to inquire at numero —, rue Condé. Here he was ushered through the wicket of a *porte cochère* into a broad, paved corridor, and up a stair into a large, cool room, and into the presence of a man who seemed, in some respects, the most remarkable figure he had yet seen in this little city of strange people. A strong, clear, olive complexion; features that were faultless (unless a woman-like delicacy, that was yet not effeminate, was a fault); hair *en queue*, the handsomer for its premature streakings of gray; a tall, finely knit form, attired in cloth, linen and leather of the utmost fineness; manners Castilian, with a gravity almost oriental,—made him one of those rare masculine figures which, on the public promenade, men look back at and ladies inquire about.

Now, who might *this* be? The rent poster had given no name. Even the incurious Frowenfeld would fain guess a little. For a man to be just of this sort, it seemed plain that he must live in isolated ease upon the unceasing droppings of coupons, rents, and like receivables. Such was the immigrant's first conjecture; and, as with slow, scant questions and answers they made their bargain, every new glance strengthened it;

he was evidently a *rentier*. What, then, was his astonishment when Monsieur bent down and made himself Frowenfeld's landlord; by writing what the universal mind esteemed the synonym of enterprise and activity—the name of Honoré Grandissime. The landlord did not see, or ignored, his tenant's glance of surprise, and the tenant asked no questions.

We may add here an incident which seemed, when it took place, as unimportant as a single fact well could be.

The little sum that Frowenfeld had inherited from his father had been sadly depleted by the expenses of four funerals; yet he was still able to pay a month's rent in advance, to supply his shop with a scant stock of drugs, to purchase a celestial globe and some scientific apparatus, and to buy a dinner or two of sausages and crackers; but after this there was no necessity of hiding his purse.

His landlord early contracted a fondness for dropping in upon him, and conversing with him, as best the few and labored English phrases at his command would allow. Frowenfeld soon noticed that he never entered the shop unless its proprietor was alone, never sat down, and always, with the same perfection of dignity that characterized all his movements, departed immediately upon the arrival of any third person. One day, when the landlord was making one of these standing calls,—he always stood beside a high glass case, on the side of the shop opposite the counter,—he noticed in Joseph's hand a sprig of basil, and spoke of it.

"You ligue?"

The tenant did not understand.

"You—fine—dad—nize?"

Frowenfeld replied that it had been left by the oversight of a customer, and expressed a liking for its odor.

"Ah sane you," said the landlord,—a speech whose meaning Frowenfeld was not sure of until the next morning, when a small, nearly naked, black boy, who could not speak a word of English, brought to the apothecary a luxuriant bunch of this basil, growing in a rough box.

CHAPTER IX.

ILLUSTRATING THE TRACTIVE POWER OF BASIL.

ON the twenty-fourth day of December, 1803, at two o'clock, P. M., the thermometer standing at 79, hygrometer 17, barometer

29.880, sky partly clouded, wind west, light, the apothecary of the rue Royale, now something more than a month established in his calling, might have been seen standing behind his counter and beginning to show embarrassment in the presence of a lady, who, since she had got her prescription filled and had paid for it, ought in the conventional course of things to have gone out, followed by the pathetically ugly black woman who tarried at the door as her attendant. She was heavily veiled; but the sparkle of her eyes, which no multiplication of veils could quite extinguish, her symmetrical and well-fitted figure, just escaping smallness, her grace of movement, and a soft, joyous voice, had several days before led Frowenfeld to the confident conclusion that she was young and beautiful.

For this was now the third time she had come to buy; and, though the purchases were trivial, the purchaser seemed not so. On the two previous occasions she had been accompanied by a slender girl, somewhat taller than she, veiled also, of graver movement, and of a bearing that seemed to Joseph almost too regal, with a certain family resemblance between her voice and that of the other, that proclaimed them—he incautiously assumed—sisters. This time, as we see, the smaller, and probably elder, came alone.

She still held in her hand the small silver which Frowenfeld had given her in change, and sighed after the laugh they had just enjoyed together over a slip in her English. A very grateful sip of sweet the laugh was to the all but friendless apothecary, and the embarrassment that rushed in after it may have arisen in part from a conscious casting about in his mind for something—anything—that might prolong her stay an instant. He opened his lips to speak; but she was quicker than he, and said, in a stealthy way that seemed oddly unnecessary:

“You ’ave some basilic?”

She accompanied her words with a little peeping movement, directing his attention, through the open door, to his box of basil, on the floor in the rear room.

Frowenfeld stepped back to it, cut half the bunch, and returned, with the bold intention of making her a present of it; but as he hastened back to the spot he had left, he was astonished to see the lady disappearing from his farthest front door, followed by her negress.

“Did she change her mind, or did she misunderstand me?” he asked himself; and,

in the hope that she might return for the basil, he put it in water in his back room.

The day being, as the figures have already shown, an unusually mild one, even for a Louisiana December, and the finger of the clock drawing by and by toward the last hour of sunlight, some half dozen of Frowenfeld’s townsmen had gathered, inside and out, some standing, some sitting, about his front door, and all discussing the popular topics of the day. For it might have been anticipated that, in a city where so very little English was spoken and no newspaper published except that beneficiary of eighty subscribers, the “*Moniteur de la Louisiane*,” the apothecary shop in the rue Royale would be the rendezvous for a select company of English-speaking gentlemen, with a smart majority of physicians.

The Cession had become an accomplished fact. With due drum-beatings and act-reading, flag-raising, cannonading and galloping of aides-de-camp, Nouvelle Orleans had become New Orleans, and Louisiane was Louisiana. This afternoon, the first week of American jurisdiction was only something over half gone, and the main topic of public debate was still the Cession. Was it genuine? and, if so, would it stand?

“Mark my words,” said one, “the British flag will be floating over this town within ninety days!” and he went on whittling the back of his chair.

From this main question, the conversation branched out to the subject of land-titles. Would that great majority of Spanish titles derived from the concessions of post-commandants and others of minor authority, hold good?

“I suppose you know what ——— thinks about it?”

“No.”

“Well, he has quietly purchased the grant made by Carondelet to the Marquis of ———, thirty thousand acres, and now says the grant is two hundred *and* thirty thousand. That is one style of men Governor Claiborne is going to have on his hands. The town will presently be as full of them as my pocket is of tobacco-crumbs,—every one of them with a Spanish grant as long as Clark’s ropewalk, and made up since the rumor of the Cession.”

“I hear that some of Honoré Grandissime’s titles are likely to turn out bad,—some of the old Brahmin properties and some of the Mandarin lands.”

“Fudge!” said Doctor Keene.

There was also the subject of rotation in

office. Would this provisional governor-general himself be able to stand fast? Had not a man better temporize a while, and see what Casa Calvo and Trudeau were going to do? Would not men who sacrificed old prejudices, braved the popular contumely, and came forward and gave in their allegiance to the President's appointee, have to take the chances of losing their official positions at last? Men like Camille Brahmin, for instance, or Charlie Mandarin: suppose Spain or France should get the province back, then where would they be?

"One of the things I pity most in this vain world," drawled Doctor Keene, "is a hive of patriots who don't know where to swarm."

The apothecary was drawn into the discussion—at least he thought he was. Inexperience is apt to think that Truth will be knocked down and murdered unless she comes to the rescue. Somehow, Frowenfeld's really excellent arguments seemed to give out more heat than light. They were merciless; their principles were not only lofty to dizziness, but precipitous, and their heights unoccupied, and—to the common sight—unattainable. In consequence, they provoked hostility and even resentment. With the most honest, the kindest, and even the most modest, intentions, he found himself—to his bewilderment and surprise—sniffed at by the ungenerous, frowned upon by the impatient, and smiled down by the good-natured, in a manner that brought sudden blushes of exasperation to his face, and often made him ashamed to find himself going over these sham battles again in much savageness of spirit, when alone with his books; or, in moments of weakness, casting about for such unworthy weapons as irony and satire. In the present debate, he had just provoked a sneer that made his blood leap and his friends laugh, when Doctor Keene, suddenly rising and beckoning across the street, exclaimed:

"Oh! Agricole! Agricole! *venez ici*; we want you."

A murmur of vexed protest arose from two or three.

"He is coming," said the whittler, who had also beckoned.

"Good evening, Citizen Fusilier," said Doctor Keene. "Citizen Fusilier, allow me to present my friend, Professor Frowenfeld—yes, you are a professor—yes, you are. He is one of your sort, Citizen Fusilier, a man of thorough scientific education. I believe on my soul, sir, he knows nearly as much as you do!"

The person who confronted the apothecary was a large, heavily built, but well molded and vigorous man, of whom one might say that he was adorned with old age. His brow was dark, and furrowed partly by time and partly by a persistent ostentatious frown. His eyes were large, black and bold, and the gray locks above them curled short and harsh like the front of a bull. His nose was fine and strong, and if there was any deficiency in mouth or chin, it was hidden by a beard that swept down over his broad breast like the beard of a prophet. In his dress, which was noticeably soiled, the fashions of three decades were hinted at; he seemed to have donned whatever he thought his friends would most have liked him to leave off.

"Professor," said the old man, extending something like the paw of a lion, and giving Frowenfeld plenty of time to become thoroughly awed, "this is a pleasure as magnificent as unexpected! A scientific man?—in Louisiana?" He looked around upon the doctors as upon a graduating class. "Professor, I am rejoiced!" He paused again, shaking the apothecary's hand with great ceremony. "I do assure you, sir, I dislike to relinquish your grasp. Do me the honor to allow me to become your friend! I congratulate my down-trodden country on the acquisition of such a citizen! I hope, sir,—at least I might have hoped, had not Louisiana just passed into the hands of the most clap-trap government in the universe, notwithstanding it pretends to be a republic,—I might have hoped that you had come among us to fasten the lie direct upon a late author, who writes of us that 'the air of this region is deadly to the Muses.'"

"He didn't say that?" asked one of the debaters, with pretended indignation.

"He did, sir, after eating our bread!"

"And sucking our sugar-cane, too, no doubt!" said the inquirer; but the old man took no notice of the irony.

Frowenfeld, naturally, was not anxious to reply, and was greatly relieved to be touched on the elbow by a child with a picayune in one hand and a tumbler in the other. He escaped behind the counter and gladly remained there.

"Citizen Fusilier," asked one of the gossips, "what has the new government to do with the health of the Muses?"

"It introduces the English tongue," said the old man scowling.

"Oh, well," replied the questioner, "the Creoles will soon learn the language."

"English is not a language, sir; it is a jargon! And when this young simpleton, Claiborne, attempts to cram it down the public windpipe in the courts, as I understand he intends, he will fail! Hah! sir, I know men in this city who would rather eat a dog than speak English! I speak it, but I also speak Choctaw."

"The new land titles will be in English."

"They will spurn his rotten titles. And if he attempts to invalidate their old ones, why, let him do it! Napoleon Buonaparte" (Italian pronunciation) "will make good every arpent within the next two years. *Think so?* I know it! *How?* H-I perceive it! H-I hope the yellow fever may spare you to witness it."

A sullen grunt from the circle showed the "citizen" that he had presumed too much upon the license commonly accorded his advanced age, and by way of a diversion he looked around for Frowenfeld to pour new flatteries upon. But Joseph, behind his counter, unaware of either the offense or the resentment, was blushing with pleasure before a visitor who had entered by the side door farthest from the company.

"Gentlemen," said Agricola, "h-my dear friends, you must not expect an old Creole to like anything in comparison with *la belle langue*."

"Which language do you call *la belle*?" asked Doctor Keene, with pretended simplicity.

The old man bent upon him a look of unspeakable contempt, which nobody noticed. The gossips were one by one stealing a glance toward that which ever was, is and must be, an irresistible lodestone to the eyes of all the sons of Adam, to wit, a chaste and graceful complement of—skirts. Then, in a lower tone, they resumed their desultory conversation.

It was the seeker after basil who stood before the counter, holding in her hand, with her purse, the heavy veil whose folds had before concealed her features.

CHAPTER X.

"OO DAD IS, 'SIEUR FROWENFEL'?"

WHETHER the removal of the veil was because of the milder light of evening, or the result of accident, or of haste, or both, or whether, by reason of some exciting or absorbing course of thought, the wearer had withdrawn it unconsciously, was a matter that occupied the apothecary as little as

did Agricola's continued harangue. As he looked upon the fair face through the light gauze which still overhung but not obscured it, he readily perceived, despite the sprightly smile, something like distress, and as she spoke this became still more evident in her hurried undertone.

"'Sieur Frowenfel', I want you to sell me doze *basilic*."

As she slipped the rings of her purse apart her fingers trembled.

"It is waiting for you," said Frowenfeld; but the lady did not hear him; she was giving her attention to the loud voice of Agricola saying in the course of discussion:

"The Louisiana Creole is the noblest variety of enlightened man!"

"Oo dad is, 'Sieur Frowenfel'?" she asked, softly, but with an excited eye.

"That is Mr. Agricola Fusilier," answered Joseph in the same tone, his heart leaping inexplicably as he met her glance. With an angry flush she looked quickly around, scrutinized the old man in an instantaneous, thorough way, and then glanced back at the apothecary again, as if asking him to fulfill her request the quicker.

He hesitated, in doubt as to her meaning.

"Wrap it yonder," she almost whispered.

He went, and in a moment returned, with the basil only partially hid in a paper covering.

But the lady, muffled again in her manifold veil, had once more lost her eagerness for it; at least, instead of taking it, she moved aside, offering room for a masculine figure just entering. She did not look to see who it might be—plenty of time to do that by accident, by and by. There she made a mistake; for the new-comer, with a silent bow of thanks, declined the place made for him, moved across the shop, and occupied his eyes with the contents of the glass case, his back being turned to the lady and Frowenfeld. The apothecary recognized the Creole whom he had met under the live-oak.

The lady put forth her hand suddenly to receive the package. As she took it and turned to depart, another small hand was laid upon it and it was returned to the counter. Something was said in a low-pitched undertone, and the two sisters—if Frowenfeld's guess was right—confronted each other. For a single instant only they stood so; an earnest and hurried murmur of French words passed between them, and they turned together, bowed with great suavity, and were gone.

"The Cession is a mere temporary political maneuver!" growled M. Fusilier.

Frowenfeld's merchant friend came from his place of waiting, and spoke twice before he attracted the attention of the bewildered apothecary.

"Good-day, Mr. Frhownfeld; I have been told that ——"

Joseph gazed after the two ladies crossing the street, and felt uncomfortable that the group of gossips did the same. So did the black attendant, who glanced furtively back.

"Good day, Mr. Frhownfeld; I——"

"Oh! how do you do, sir?" exclaimed the apothecary, with great pleasantness of face. It seemed the most natural thing that they should resume their late conversation just where they had left off, and that would certainly be pleasant. But the man of more experience showed an unresponsive expression, that was as if he remembered no conversation of any note.

"I have been told that you might be able to rheaplace the glass in this thing out of yo' prhivate stock."

He presented a small, leather-covered case, evidently containing some optical instrument. "It will give me a pretext for going," he had said to himself, as he put it into his pocket in his counting-room. He was not going to let the apothecary know he had taken such a fancy to him.

"I do not know," replied Frowenfeld, as he touched the spring of the case; "I will see what I have."

He passed into the back room, more than willing to get out of sight till he might better collect himself.

"I do not keep these things for sale," said he as he went.

"Sir?" asked the Creole, as if he had not understood, and followed through the open door.

"Is this what that lady was getting?" he asked, touching the remnant of the basil in the box.

"Yes, sir," said the apothecary, with his face in the drawer of a table.

"They had no carriage with them." The Creole spoke with his back turned, at the same time running his eyes along a shelf of books. Frowenfeld made only the sound of rejecting bits of crystal and taking up others. "I do not know who they ah," ventured the merchant.

Joseph still gave no answer, but a moment after approached, with the instrument in his extended hand.

"You had it? I am glad," said the

owner, receiving it, but keeping one hand still on the books.

Frowenfeld put up his materials.

"Mr. Frhownfeld, ah these yo' books? I mean, do you use these books?"

"Yes, sir."

The Creole stepped back to the door.

"Agrhicola!"

"*Quoi!*"

"*Vien ici.*"

Citizen Fusilier entered, followed by a small volley of retorts from those with whom he had been disputing, and who rose as he did. The stranger said something very sprightly in French, running the back of one finger down the rank of books, and a lively dialogue followed.

"You must be a grheat scholla," said the unknown by and by, addressing the apothecary.

"He is a professor of chimistry," said the old man.

"I am nothing, as yet, but a student," said Joseph, as the three returned into the shop; "certainly not a scholar, and still less a professor." He spoke with a new quietness of manner that made the younger Creole turn upon him a pleasant look.

"H-my young friend," said the patriarch, turning toward Joseph with a tremendous frown, "when I, Agricola Fusilier, pronounce you a professor, you are a professor. Louisiana will not look to *you* for your credentials; she will look to me!"

He stumbled upon some slight impediment under foot. There were times when it took but little to make Agricola stumble.

Looking to see what it was, Joseph picked up a silken purse. There was a name embroidered on it.

CHAPTER XI.

SUDDEN FLASHES OF LIGHT.

THE day was nearly gone. The company that had been chatting at the front door, and which in warmer weather would have tarried until bed-time, had wandered off; however, by stepping toward the light the young merchant could decipher the letters on the purse. Citizen Fusilier drew out a pair of spectacles, looked over his junior's shoulder, read aloud, "*Aurore De G. Nanca——*," and uttered an imprecation.

"Do not speak to me!" he thundered; "do not approach me! she did it maliciously!"

"Sir!" began Frowenfeld.

But the old man uttered another tremen-

dous malediction and hurried into the street and away.

"Let him pass," said the other Creole, calmly.

"What is the matter with him?" asked Frowenfeld.

"He is getting old." The Creole extended the purse carelessly to the apothecary.

"Has it anything inside?"

"But a single pistareen."

"That is why she wanted the *basilic*, eh?"

"I do not understand you, sir."

"Do you not know what she was going to do with it?"

"With the basil? No, sir."

"May be she was going to make a little *tisane*, eh?" said the Creole, forcing down a smile.

But a portion of the smile would come when Frowenfeld answered, with unnecessary resentment:

"She was going to make some *proper* use of it, which need not concern me."

"Without doubt."

The Creole quietly walked a step or two forward and back and looked idly into the glass case. "Is this young man in love with her?" he asked himself. He turned around.

"Do you know those ladies, Mr. Frhowenfeld? Do you visit them at home?"

He drew out his porte-monnaie.

"No, sir."

"I will pay you fo' the rheapair-h of this instrhument; have you change fo'——"

"I will see," said the apothecary.

As he spoke he laid the purse on a stool, till he should light his shop and then went to his till without again taking it.

The Creole sauntered across to the counter and nipped the herb which still lay there.

"Mr. Frhowenfeld, you know what some verhy excellent people do with this? They rhub it on the sill of the do' to make the money come into the house."

Joseph stopped aghast with the drawer half drawn.

"Not persons of intelligence and ——"

"All kinds. It is only some of the foolishness which they take frhom the slaves. Many of ow best people consult the voudou hosses."

"Horses?"

"Priestesses, you might call them," explained the Creole, "like Momselle Marcelleine, or 'Zabeth Philosophe."

"Witches!" whispered Frowenfeld.

"Oh no," said the other with a shrug;

"that is too hahd a name; say fo'tune-telle's. But Mr. Frhowenfeld, I wish you to lend me yo' good offices. Just supposing the possibility that that lady may be in need of money, you know, and will send back or come back fo' the purse, you know, knowing that she most likely lost it here-h, I ask you the favo' that you will not let her know I have filled it with gold. In fact, if she mentions my name——"

"To confess the truth, sir, I am not acquainted with your name."

The Creole smiled a genuine surprise.

"I thought you knew it." He laughed a little at himself. "We have nevvatheless become verhy good frihends—I believe? Well, in fact then, Mr. Frhowenfeld, you might say you do not know who put the money in." He extended his open palm with the purse hanging across it. Joseph was about to object to this statement, but the Creole, putting on an expression of anxious desire, said: "I mean, not by name. It is somewhat impawtant to me, Mr. Frhowenfeld, that that lady should not know my prhesent action. If you want to do those two ladies a favoh, you may rhest assu'ed the way to do it is to say you do not know who put this gold." The Creole in his earnestness slipped in his idiom. "You will excuse me if I do not tell you my name; you can find it out at any time frhom Agrhicola. Ah! I am glad she did not see me! You must not tell anybody about this little event, eh?"

"No, sir," said Joseph, as he finally accepted the purse. "I shall say nothing to any one else, and only what I cannot avoid saying to the lady and her sister."

"'Tis not *heh sista*," responded the Creole, '*'tis heh daughta*."

The italics signify, not how the words were said, but how they sounded to Joseph. As if a dark lantern were suddenly turned full upon it, he saw the significance of Citizen Fusilier's transport. The fair strangers were the widow and daughter of the man whom Agricola had killed in duel—the ladies with whom Doctor Keene had desired to make him acquainted.

"Well, good-evening, Mr. Frhowenfeld." The Creole extended his hand (his people are great hand-shakers). "Ah——" and then, for the first time, he came to the true object of his visit. "The conve'sation we had some weeks ago, Mr. Frhowenfeld, has stahsted a trhain of thought in my mind"—he began to smile as if to convey the idea that Joseph would find the subject a trivial

one—"which has almost brought me to the——"

A light footfall accompanied with the soft sweep of robes caused him to cease. There had been two or three entrances and exits during the time the Creole had tarried, but he had not allowed them to disturb him. Now, however, he had no sooner turned and fixed his glance upon this last comer, than without so much as the invariable Creole leave-taking of "Well, good-evening, sir," he hurried out.

CHAPTER XII.

THE PHILOSOPHE.

THE apothecary felt an inward nervous start as there advanced into the light of his hanging lamp and toward the spot where he had halted, just outside the counter, a woman of the quadroon caste, of superb stature and poise, severely handsome features, clear, tawny skin and large, passionate black eyes.

"*Bon soir, Miché.*" [Monsieur.] A rather hard, yet not repellent smile showed her faultless teeth.

Frowenfeld bowed.

"*Mo vien c'erc'er la bourse de Madame.*"

She spoke the best French at her command, but it was not understood.

The apothecary could only shake his head.

"*La bourse,*" she repeated, softly smiling, but with a scintillation of the eyes in resentment of his scrutiny. "*La bourse,*" she reiterated.

"Purse?"

"*Oui, Miché.*"

"You are sent for it?"

"*Oui, Miché.*"

He drew it from his breast pocket and marked the sudden glisten of her eyes, reflecting the glisten of the gold in the silken mesh.

"*Oui, c'est ça,*" said she, putting her hand out eagerly.

"I am afraid to give you this to-night," said Joseph.

"*Oui,*" ventured she, dubiously, the lightning playing deep back in her eyes.

"You might be robbed," said Frowenfeld. "It is very dangerous for you to be out alone. It will not be long until gun-fire." (Eight o'clock P. M.—the gun to warn slaves to be in-doors, under pain of arrest and imprisonment.)

The object of this solicitude shook her

head with a smile at its gratuitousness. The smile showed determination also.

"*Mo pas compren',*" she said.

"Tell the lady to send for it to-morrow."

She smiled helplessly and somewhat vexedly, shrugged and again shook her head. As she did so she heard footsteps and voices in the door at her back.

"*C'est ça,*" she said again with a hurried attempt at extreme amiability; "Dat it; *oui.*" and lifting her hand with some rapidity made a sudden eager reach for the purse, but failed.

"No!" said Frowenfeld, indignantly.

"Hello!" said Charlie Keene amusedly, as he approached from the door.

The woman turned, and in one or two rapid sentences in the Creole dialect offered her explanation.

"Give her the purse, Joe; I will answer for it's being all right."

Frowenfeld handed it to her. She started to pass through the door in the rue Royale by which Doctor Keene had entered; but on seeing on its threshold Agricola frowning upon her, she turned quickly with evident trepidation, and hurried out into the darkness of the other street.

Agricola entered. Doctor Keene looked about the shop.

"I tell you, Agricole, you didn't have it with you; Frowenfeld, you haven't seen a big knotted walking-stick?"

Frowenfeld was sure no walking-stick had been left there.

"Oh yes, Frowenfeld," said Doctor Keene, with a little laugh as the three sat down, "I'd a'most as soon trust that woman as if she was white."

The apothecary said nothing.

"How free," said Agricola, beginning with a meditative gaze at the sky without, and ending with a philosopher's smile upon his two companions,— "how free we people are from prejudice against the negro!"

"The white people," said Frowenfeld, half abstractedly, half inquiringly.

"H-my young friend, when we say, 'we people,' we *always* mean we white people. The non-mention of color always implies pure white; and whatever is not pure white is to all intents and purposes pure black. When I say the 'whole community,' I mean the whole white portion; when I speak of the 'undivided public sentiment,' I mean the sentiment of the white population. What else could I mean? Could you suppose, sir, the expression which you may have heard me use—'my down-trod-

den country' includes blacks and mulattoes? What is that up yonder in the sky? The moon. The new moon, or the old moon, or the moon in her third quarter, but always the moon! Which part of it? Why, the shining part—the white part, always and only! Not that there is a prejudice against the negro. By no means. Wherever he can be of any service in a strictly menial capacity we kindly and generously tolerate his presence."

Was the immigrant growing wise, or weak, that he remained silent?

Agricola rose as he concluded and said he would go home. Doctor Keene gave him his hand lazily, without rising.

"Frowenfeld," he said, with a smile, and in an undertone as Agricola's footsteps died away, "don't you know who that woman is?"

"No."

"Well, I'll tell you."

He told him.

On that lonely plantation at the Cannes Brulées, where Aurore Nancanou's childhood had been passed without brothers or sisters, there had been given her, according to the well-known custom of plantation life, a little quadroon slave-maid as her constant and only playmate. This maid began early to show herself in many ways remarkable. While yet a child she grew tall, lithe, agile; her eyes were large and black, and rolled and sparkled if she but turned to answer to her name. Her pale yellow forehead, low and shapely, with the jet hair above it, the heavily penciled eyebrows and long lashes below, the faint red tinge that blushed with a kind of cold passion through the clear yellow skin of the cheek, the fullness of the red, voluptuous lips and the roundness of her perfect neck, gave her, even at fourteen, a barbaric and magnetic beauty, that startled the beholder like an unexpected drawing out of a jeweled sword. Such a type could have sprung only from high Latin ancestry on the one side and—we might venture—Jaloff African on the other. To these charms of person she added mental acuteness, conversational adroitness, concealed cunning and noiseless but visible strength of will; and to these, that rarest of gifts in one of her tincture, the purity of true womanhood.

At fourteen a necessity which had been parleyed with for two years or more became imperative and Aurore's maid was taken from her. Explanation is almost superflu-

ous. Aurore was to become a lady and her playmate a lady's maid; but not *her* maid, because the maid had become, of the two, the ruling spirit. It was a question of grave debate in the mind of M. De Grapion what disposition to make of her.

About this time the Grandissimes and De Grapions, through certain efforts of Honoré's father (since dead) were making some feeble pretenses of mutual good feeling, and one of those Kentuckian dealers in corn and tobacco whose flat-boat fleets were always drifting down the Mississippi, becoming one day M. De Grapion's transient guest, accidentally mentioned a wish of Agricola Fusilier. Agricola, it appeared, had commissioned him to buy the most beautiful lady's maid that in his extended journeyings he might be able to find; he wanted to make her a gift to his niece, Honoré's sister. The Kentuckian saw the demand met in Aurore's playmate. M. De Grapion would not sell her. (Trade with a Grandissime? Let them suspect he needed money?) No; but he would ask Agricola to accept the services of the waiting-maid for, say, ten years. The Kentuckian accepted the proposition on the spot and it was by and by carried out. She was never recalled to the Cannes Brulées, but in subsequent years received her freedom from her master, and in New Orleans became Palmyre la Philosophe, as they say in the corrupt French of the old Creoles, or Palmyre Philosophe, noted for her taste and skill as a hair-dresser, for the efficiency of her spells and the sagacity of her divinations, but most of all for the chaste austerity with which she practiced the less baleful rites of the voodoo.

"That's the woman," said Doctor Keene, rising to go, as he concluded the narrative,—"that's she, Palmyre Philosophe. Now you get a view of the vastness of Agricole's generosity; he tolerates her even though she does not present herself in the 'strictly menial capacity.' Reason why—*he's afraid of her.*"

Time passed, if that may be called time which we have to measure with a clock. The apothecary of the rue Royale found better ways of measurement. As quietly as a spider he was spinning information into knowledge and knowledge into what he supposed to be wisdom; whether it was or not we shall see. His unidentified merchant friend who had adjured him to become acclimated as "they all did" had also

exhorted him to study the human mass of which he had become a unit; but whether that study, if pursued, was sweetening and ripening, or whether it was corrupting him that friend did not come to see; it was the busy time of year. Certainly so young a solitary, coming among a people whose conventionalities were so at variance with his own door-yard ethics, was in sad danger of being unduly—as we might say—Timonized. His acquaintances continued to be few in number.

During this fermenting period he chronicled much wet and some cold weather. This may in part account for the uneventfulness of its passage: events do not happen rapidly among the Creoles in bad weather. However, trade was good.

But the weather cleared; and when it was getting well on into the Creole spring and approaching the spring of the almanacs, something did occur that extended Frowenfeld's acquaintance without Doctor Keene's assistance.

CHAPTER XIII.

A CALL FROM THE RENT-SPECTER.

It is nearly noon of a balmy morning late in February. Aurore Nancanou and her daughter have only this moment ceased sewing, in the small front room of No. 19 rue Bienville. Number 19 is the right-hand half of a single-story, low-roofed tenement, washed with yellow ochre, which it shares generously with whoever leans against it. It sits as flat on the ground as a toad. There is a kitchen belonging to it somewhere among the weeds in the back yard, and, besides this room where the ladies are, there is, directly behind it, a sleeping apartment. Somewhere back of this there is a little nook where in pleasant weather they eat. Their cook and housemaid is the very plain person who attends them on the street. Her bed-chamber is the kitchen and her bed the floor. The house's only other protector is a hound, the aim of whose life is to get thrust out of the ladies' apartments every fifteen minutes.

Yet if you hastily picture to yourself a forlorn-looking establishment, you will be moving straight away from the fact. Neatness, order, excellence, are prevalent qualities in all the details of the main house's inward garniture. The furniture is old-fashioned, rich, French, imported. The carpets, if not new, are not cheap, either. Bits

of crystal and silver, visible here and there, are as bright as they are antiquated; and one or two portraits, and the picture of Our Lady of Many Sorrows, are passably good productions. The brass work, of which there is much, is brilliantly burnished, and the front room is bright and cheery.

At the street door of this room somebody has just knocked. Aurore has risen from her seat. The other still sits on a low chair with her hands and sewing dropped into her lap, looking up steadfastly into her mother's face with a mingled expression of fondness and dismayed expectation. Aurore hesitates beside her chair, desirous of resuming her seat, even lifts her sewing from it; but tarries a moment, her alert suspense showing in her eyes. Her daughter still looks up into them. It is not strange that the dwellers round about dispute as to which is the fairer, nor that in the six months during which the two have occupied Number 19 the neighbors have reached no conclusion on this subject. If some young enthusiast compares the daughter—in her eighteenth year—to a bursting blush rosebud full of promise, some older one immediately retorts that the other—in her thirty-fifth—is the red, red, full-blown, faultless joy of the garden. If one says the maiden has the dew of youth,—“But!” cry two or three mothers in a breath, “that other one, child, will never grow old. With her it will always be morning. That woman is going to last forever; ha-a-a-a!—even longer!”

There was one direction in which the widow evidently had the advantage; you could see from the street or the opposite windows that she was a wise householder. On the day they moved into Number 19 she had been seen to enter in advance of all her other movables, carrying into the empty house a new broom, a looking-glass, and a silver coin. Every morning since, a little watching would have discovered her at the hour of sunrise sprinkling water from her side casement, and her opposite neighbors often had occasion to notice that, sitting at her sewing by the front window, she never pricked her finger but she quickly ran it up behind her ear, and then went on with her work. Would anybody but Joseph Frowenfeld ever have lived in and moved away from a two-story brick next them on the right and not have known of the existence of such a marvel?

“Ha!” they said, “she knows how to keep off bad luck, that Madame yonder.

And the younger one seems not to like it. Girls think themselves so smart these days."

Ah, there was the knock again, right there on the street-door, as loud as if it had been given with a joint of sugar-cane!

The daughter's hand, which had just resumed the needle, stood still in mid-course with the white thread half drawn. Aurore tiptoed slowly over the carpeted floor. There came a shuffling sound, and the corner of a folded white paper commenced appearing and disappearing under the door. She mounted a chair and peeped through that odd little *jalousie* which formerly was in almost all New Orleans street-doors; but the missive had meantime found its way across the sill, and she saw only the unpicturesque back of a departing errand-boy. But that was well. She had a pride, to maintain which—and a poverty, to conceal which—she felt to be necessary to her self-respect; and this made her of necessity a trifle unsocial in her own castle. Do you suppose she was going to put on the face of having been born or married to this degraded condition of things?

Who knows?—the knock might have been from 'Sieur Frowenfel'—ha, ha! He might be just silly enough to call so early; or it might have been from that *polisson* of a Grandissime,—which one didn't matter, they were all detestable,—coming to collect the rent. That was her original fear; or, worse still, it might have been, had it been softer, the knock of some possible lady-visitor. She had no intention of admitting any feminine eyes to detect this carefully covered up indignity. Besides, it was Monday. There is no sense in trifling with bad luck. The reception of Monday callers is a source of misfortune never known to fail, save in rare cases when good luck has already been secured by smearing the front walk or the banquette with Venetian red.

Before the daughter could dart up and disengage herself from her work her mother had pounced upon the paper. She was standing and reading, her rich black lashes curtaining their downcast eyes, her infant waist and round, close-fitted, childish arms harmonizing prettily with her mock frown of infantile perplexity, and her long, limp robe heightening the grace of her posture, when the younger started from her seat with the air of determining not to be left at a disadvantage.

But what is that on the dark eyelash? With a sudden additional energy the daughter dashes the sewing and chair to right and

left, bounds up, and in a moment has Aurore weeping in her embrace and has snatched the note from her hand.

"Ah! *maman!* Ah! *ma chère mère!*"

The mother forced a laugh. She was not to be mothered by her daughter; so she made a dash at Clotilde's uplifted hand to recover the note, which was unavailing. Immediately there arose in colonial French the loveliest of contentions, the issue of which was that the pair sat down side by side, like two sisters over one love-letter, and undertook to decipher the paper. It read as follows:

"NEW ORLEANS, 20 Feb're, 1804.

"MADAME NANCANOU: I muss oblige to ass you for rent of that house whare you living, it is at numer 19 Bienville street whare I do not received thos rent from you not since tree mons and I demand you this is mabe thirteen time. And I give to you notice of 19 das written in English as the new law requi. That witch the law make necessare only for 15 das, and when you not pay me those rent in 19 das till the tense of Marh I will rekes you to move out. That witch make me to be very sorry I have the honor to remain, Madam,

"Your humble servant,

"H. GRANDISSIME,

"per Z. F."

There was a short French postscript on the opposite page signed only by M. Zénon François, explaining that he, who had allowed them in the past to address him as their landlord and by his name, was but the landlord's agent; that the landlord was a far better-dressed man than he could afford to be; that the writing opposite was a notice for them to quit the premises they had rented (not leased), or pay up; that it gave the writer great pain to send it, although it was but the necessary legal form and he only an irresponsible drawer of an inadequate salary, with thirteen children to support; and that he implored them to tear off and burn up this postscript immediately they had read it.

"Ah, the miserable!" was all the comment made upon it as the two ladies addressed their energies to the previous English. They had never suspected him of being M. Grandissime.

Their eyes dragged slowly and ineffectually along the lines to the signature.

"H. Grandissime! Loog ad 'im!" cried the widow, with a sudden short laugh, that brought the tears after it like a wind-gust in a rose-tree. She held the letter out before them as if she was lifting something alive by the back of the neck, and to intensify her scorn spoke in the hated tongue pre-

scribed by the new courts. "Loog ad 'im! dad ridge gen'leman oo give so mudge money to de 'ozpill!"

"Bud, *maman*," said the daughter, laying her hand appealingly upon her mother's knee, "ee do nod know 'ow we is poor."

"Ah!" retorted *Aurore*, "*par exemple!* Non? Ee thingue we is ridge, eh? Ligue his oncle, eh? Ee thing so too, eh?" She cast upon her daughter the look of burning scorn intended for *Agricola Fusilier*. "You wan' to tague the pard of dose Grandissime?"

The daughter returned a look of agony.

"No," she said, "bud a man wad godd some 'ouses to rend, muz ee nod boun' to ged 'is rend?"

"Boun' to ged—ah! yez ee muz do 'is possible to ged 'is rend. Oh! certain*lee*. Ee is ridge, bud ee need a lill money, bad, bad. Fo' w'at?" The excited speaker rose to her feet under a sudden inspiration. "*Tenez, Mademoiselle!*" She began to make great show of unfastening her dress.

"*Mais, comment?*" demanded the suffering daughter.

"Yez!" continued *Aurore*, keeping up the demonstration, "you wand 'im to 'ave 'is rend so bad! An' I godd honely my cloze; so you juz tague diz to you' fine gen'leman, 'Sieur Honoré Grandissime."

"Ah-h-h-h!" cried the martyr.

"An' you is right," persisted the tormentor, still unfastening; but the daughter's tears gushed forth, and the repentant tease threw herself upon her knees, drew her child's head into her bosom and wept afresh.

Ah! there is a power in hydraulics of which natural philosophy speaketh not. There be tears that weaken and tears that debase; but when two women are in trouble—more trouble than they can speak, and have none to cling to but each other, your "good cry" mutually enjoyed, cools the air like a Nile freshet, revives fortitude, new-fertilizes hope and gives the widow and the fatherless strength to rise up and smile like the fruitful fields.

Half an hour was passed in council; at the end of which they stood beneath their lofty mantel-shelf, each with a foot on a brazen fire-dog, and no conclusion reached.

"Ah, my child!"—they had come to themselves now and were speaking in their peculiar French—"if we had here in these hands but the tenth part of what your papa often played away in one night without once getting angry! But we have not. Ah! but your father was a fine fellow; if he could

have lived for you to know him! So accomplished! Ha, ha, ha! I can never avoid laughing, when I remember him teaching me to speak English; I used to enrage him so!"

The daughter brought the conversation back to the subject of discussion. There were nineteen days yet allowed them. God knows—by the expiration of that time they might be able to pay. With the two music scholars whom she then had and three more whom she had some hope to get, she made bold to say they could pay the rent.

"Ah, *Clotilde*, my child," exclaimed *Aurore*, with sudden brightness, "you don't need a mask and costume to resemble your great-grandmother, the casket-girl!" *Aurore* felt sure, on her part, that with the one embroidery scholar then under her tutelage, and the three others who had declined to take lessons, they could easily pay the rent—and how kind it was of Monsieur, the aged father of that one embroidery scholar, to procure those invitations to the ball! The dear old man! He said he must see one more ball before he should die.

Aurore looked so pretty in the reverie into which she fell that her daughter was content to admire her silently.

"*Clotilde*," said the mother, presently looking up, "do you remember the evening you treated me so ill?"

The daughter smiled at the preposterous charge.

"I did not treat you ill."

"Yes, don't you know—the evening you made me lose my purse?"

"Certainly, I know!" The daughter took her foot from the andiron; her eyes lighted up aggressively. "For losing your purse blame yourself. For the way you found it again—which was far worse—thank *Palmyre*. If you had not asked her to find it and shared the gold with her we could have returned with it to 'Sieur Frowenfel'; but now we are ashamed to let him see us. I do not doubt he filled the purse."

"He? He never knew it was empty. It was M. Nobody who filled it. *Palmyre* says that Papa *Lébat*—"

"Ha!" exclaimed *Clotilde* at this superstitious mention.

The mother tossed her head and turned her back, swallowing the unendurable bitterness of being rebuked by her daughter. But the cloud hung over but a moment.

"*Clotilde*," she said, a minute after, turning with a look of sun-bright resolve, "I am going to see him."

"To see whom?" asked the other, looking back from the window, whither she had gone to recover from a reactionary trembling.

"To whom, my child? Why——"

"You do not expect mercy from Honoré Grandissime? You would not ask it?"

"No. There is no mercy in the Grandissime blood; but cannot I demand justice? Ha! it is justice that I shall demand!"

"And you will really go and see him?"

"You will see, Mademoiselle," replied Aurore, dropping a broom with which she had begun to sweep up some spilled buttons.

"And I with you?"

"No! To a counting-room? To the presence of the chief of that detestable race? No!"

"But you don't know where his office is."

"Anybody can tell me."

Preparation began at once. By and by——

"Clotilde."

Clotilde was stooping behind her mother, with a ribbon between her lips, arranging a flounce.

"M-m-m."

"You must not watch me go out of sight; do you hear? * * But it is dangerous. I knew of a gentleman who watched his wife go out of his sight and she never came back!"

"Hold still!" said Clotilde.

"But when my hand itches," retorted Aurore in a high key, "haven't I got to put it instantly into my pocket if I want the money to come there! Well, then!"

The daughter proposed to go to the kitchen and tell Alphonsina to put on her shoes.

"My child," cried Aurore, "you are crazy! Do you want Alphonsina to be seized for the rent?"

"But you cannot go alone—and on foot!"

"I must go alone; and—can you lend me your carriage? Ah, you have none? Certainly I must go alone and on foot if I am to say I cannot pay the rent. It is no indiscretion of mine. If anything happens to me it is M. Grandissime who is responsible."

Now she is ready for the adventurous errand. She darts to the mirror. The high-water marks are gone from her eyes. She wheels half around and looks over her shoulder. The flaring bonnet and loose ribbons gave her a more girlish look than ever.

"Now which is the older, little old woman?" she chirruped, and smites her daughter's cheek softly with her palm.

"And you are not afraid to go alone?"

"No; but remember! look at that dog!"

The brute sinks apologetically to the floor. Clotilde opens the street door, hands Aurore the note, Aurore lays a frantic kiss upon her lips, pressing it on tight so as to get it again when she comes back, and—while Clotilde calls the cook to gather up the buttons and take away the broom, and while the cook, to make one trip of it, gathers the hound into her bosom and carries broom and dog out together—Aurore sallies forth, leaving Clotilde to resume her sewing and await the coming of a guitar scholar.

"It will keep her fully an hour," thought the girl, far from imagining that Aurore had set about a little private business which she proposed to herself to accomplish before she even started in the direction of M. Grandissime's counting-rooms.

(To be continued).

WAITING FOR WINTER.

WHAT honey in the year's last flowers can hide,
 These little yellow butterflies may know:
 With falling leaves they waver to and fro,
 Or on the swinging tops of asters ride.
 But I am weary of the summer's pride
 And sick September's simulated show:
 Why do the colder winds delay to blow
 And bring the pleasant hours that we abide;
 To curtained alcove and sweet household talks,
 Or sweeter silence by our flickering Lars,
 Returning late from autumn evening walks
 Upon the frosty hills, while reddening Mars
 Hangs low between the withered mullein stalks
 And upward throngs the host of winter stars?

BAYARD TAYLOR.

HIS POETRY AND LITERARY CAREER.

PART II.

I.

TAYLOR'S versatility is shown in his lyrical remains. Much of his poetry does not bear its maker's hand-mark so distinctly as that of Longfellow or Whittier is wont to do. His subjects and modes of treatment are exceedingly varied, and the former may be assorted in groups,—the classical pieces, the dithyrambic lyrics, the poems of travel, and those of hearth and home. In any mood he was apt to reach a certain standard of merit; he rarely failed. But there was one field—though he scarcely seemed to realize its value—so much his own as to breed for him a number of rough imitators. From it he made such studies of the rural scenes and characters he best knew, as "John Reid," "The Old Pennsylvania Farmer," and that lovely ballad, unexcelled in truth and tenderness of feeling—"The Quaker Widow":

"Thee finds me in the garden, Hannah,—come in! 'Tis kind of thee
To wait until the Friends were gone, who came to comfort me.
The still and quiet company a peace may give, indeed,
But blessed is the single heart that comes to us at need.

"Come, sit thee down! Here is the bench where Benjamin would sit
On First-day afternoons in spring, and watch the swallows flit;
He loved to smell the sprouting box, and hear the pleasant bees
Go humming round the lilacs and through the apple-trees.

"I think he loved the spring—not that he cared for flowers. Most men
Think such things foolishness—but we were first acquainted then,
One spring: the next, he spoke his mind; the third, I was his wife,
And in the spring (it happened so) our children entered life."

Some of the touches are perfect:

"'Tis hard to change so late in life, but we must be resigned;
The Lord looks down contentedly upon a willing mind."

The poet more rarely expressed that passion which feeds itself on rapture or heart-

break and the ecstasy of despair. Even his noon-day health and manliness blunted his delicacy of touch. One might well refer, in illustration of the difference between the suggestive, idealistic use of a theme and the reverse, to Heine's couplets on "The Palm and the Pine" and Taylor's longer poem with that title. And yet, when he felt with his whole heart, he could be not only refined, but highly imaginative, as in "Euphorion,"—a poem addressed to friends who had lost a dreamy and beautiful child:

"For, through the crystal of your tears,
His love and beauty fairer shine;
The shadows of advancing years
Draw back, and leave him all divine.

"And Death, that took him, cannot claim
The smallest vesture of his birth,—
The little life, a dancing flame
That hovered o'er the hills of earth,—

"The finer soul, that unto ours
A subtle perfume seemed to be,
Like incense blown from April flowers
Beside the scarred and thorny tree,—

"The wondering eyes, that ever saw
Some fleeting mystery in the air,
And felt the stars of evening draw
His heart to silence, childhood's prayer!"

These stanzas are at the top mark, I think, of Taylor's lyrical genius. The man who could write them, and who composed the Bedouin Song and the Pennsylvanian idyls, was an American poet whose fame should be dear to his countrymen. But he did much more. Of what kind, and under what conditions? Here comes in the lesson of his life as a poet, and it is chiefly as a poet that we are considering him.

Authors are most sure to give us something of value when they render the feeling of localities to which they belong. A sympathetic poet is in danger of losing his birthright through much knowledge of the world at large. Shelley wandered everywhere, but never was there a poet more subjective. He found in the haunted chambers of his own soul the music, the prophesy, which he uttered afar. The murmur of the Appenines, the mist of the Eugeanean Hills, were merely the voice and drapery of his own imagining, and with

him the ideal was the real. Byron, again, used all skies, all persons, as the mirror of himself, and forced every region to contribute to the study of his personal nature. Brummagem Byrons more than once have aped his princely progress, but Taylor was too honest and sincere to figure among these. His Byronism ended with his youth. He was patriotic, always American, and should have exhibited the national spirit in his verse no less than in his career. I think he was a poet whose mark would have been still higher had his relations been confined, if not to the section that gave him birth, at most to his own land and people.

To venture, for once, upon comparisons, I would say that the native qualities of Taylor were not unlike those of Burns and Whittier; that these three poets were more similar, as they came from the mold, than any others whom I call to mind. Burns was a healthy country lad, full of the prodigal force of Nature, blown on by her breezes, nurtured by her soil, thrilled by poetic emotions as he felt the rich sap of youth coursing through his veins. His influences were those of his own people. His first efforts imitated the didactic plodding of the "Caledonian Bards." When somewhat matured, he awoke to the beauty of the true Scottish minstrelsy, and adapted his own song to it. Suppose that opportunities for travel, wider culture, varied reading, the mastery of languages, had been given him. One nail drives out another. He might have been hampered with his acquisitions; his Muse would have subdued her strength in diverse strains; he would no longer have been the fine, untrammelled specialist,—and might have wholly lost his native wood-notes wild.

Whittier, another national poet, owes his fame, as one of the most genuine, to his seclusion—voluntary or involuntary—and to his presentation of the themes and feeling nearest the heart of New England. His work has the greater value because it pertains to these distinctive things, and thus is a specific addition to American song. His early pieces, like those of Burns, were artificial. It was not until after growth and fervid conviction that his lips were really touched with fire.

It was Taylor's good fortune, as a man who would live his life,—his ill fortune, it may be, as a poet,—to obtain the culture and experience for which his youth had longed. We admire his pluck and advent-

ure, but lament what was lost to poetry. At just the time when his fine spirit, bound within a home range, would have made the most of its surroundings, he was able to travel, and to gratify without stint his love of action and observation. Unconsciously, his Muse became bewildered. His gift and his poetic yearning were always by him; but surely he lost much in exchange for what he gained. One can readily conceive the lyrical genius of Whittier as subject to be diffused or perplexed under similar conditions. The question lies between personal attainment and the extreme utilization of an artist's special gift. Taylor chose the former. He said, "If I have any ambition, it is to enjoy as large a store of experience as this earth can furnish." Circumstances aided him in his choice. As a youth, he thought little of the effect upon his poetic career, or possibly thought he was promoting it. Later on, however "rich and ample" his life, he felt a sense of uneasiness. He cared most of all, in his heart of hearts, to be a poet, and saw that, while going afar to invoke the Muse, he had given her the less chance to seek him, as she sought out one who said, "The Poetic Genius of my country found me at the plow and threw her inspiring mantle over me." When she does visit her favorite, it is not safe to bid her wait for a more convenient season. She may hide herself when summoned, or permit a misleading phantom to take her place.

Choose between the ideal and the actual—such is the alternative of art. Few can eat their cake and have it, too. Delight of life and action has turned aside many a swift runner, as I have shown in reference to Domett and Horne, poets of a less indomitable industry than Taylor's, who found the joys of adventure even more alluring than he did, and dallied with their art for long and almost irremediable spaces.

Whatever may be said of the benefits and disadvantages of culture, it often has been a practical injury to the poet—since no one is sure of life's full limit—to set before him too high and broad an ideal. It may not always be best to aim at the sun. We ask of a man the one thing he can do better than other men, and often, as in the legend of Gaspar Becerra, "that is best which lieth nearest." Then there are hindrances born of success itself, and to these Taylor was unusually subjected. He became involved with the literary life of New York, and at a trying time. It was just early enough for him to receive a good word from Poe, and

late enough for him to witness the rout of the "literati." Even a sham literary feeling may be better than no feeling at all. The pursuit of letters now was mainly left to the Boston writers, while the New York wits and authors betook themselves to journalism, and with material success.

Has New York gained since then as a literary center? Yes, and no. It is now the base from which our authors draw their supplies. The great journals, the most profitable magazines, the largest publishing houses, are located there. It is the chief center of distribution, and will so remain until some future period shall establish a differentiation between the typical literatures of this vast country, and number as many great centers of distribution as there shall be characteristic sections. But the atmosphere,—the public feeling which alone can foster rising art and make its workmen glad and creative,—this gathers more slowly. Authors are tolerated, respected, valued as accessories; but not always understood, nor often intrusted with the care of important movements. New York has a sufficiency of writers and of literary elements for the needs of many smaller cities; but the former are without concert of action, and do not feel themselves sustained by that sympathetic interest which, for example, encourages the music of Naples, the art of Paris or Rome. What intellectual quality exists must be found among the writers, artists, savants,—of themselves numerous enough to make an audience or colonize a university town. New York is great in material progress, generous in charities; but still too practical even to affect an æsthetic sentiment. True, her wealthy classes are groping toward the comprehension of what is beautiful. They have schools of design, and are surpassing not only the troglodytes, but our more immediate ancestors, in mural decoration. But what is intellectually fine we have yet to pursue with any general ardor. The city took a pride in Bryant, for instance, as a man and as a picturesque figure on state occasions; but how many of his townsmen had read the most of his poems, or cared to read them? Meanwhile, in Boston, phrases, such as "Emerson says," or "Lowell says," have been a staple part of ordinary conversation. Herein is no reason for complaint; all is as it should be. If individuals are not coddled in New York, they at least have an equal chance, and there are not lacking assurances of a speedy and rich development. Already it is the fashion to seek

admission to the Century and the University clubs. The cry of "Asses and savants to the center!" is no longer possible. The present longing for æsthetic luxury in New York is a sign that her ideal advance has begun. Her golden age of art and literature cannot be far distant; the public temper will of itself breed her artists and poets.

Taylor's lot was thus cast in a somewhat uncongenial city, and he often found himself praised and courted where he needed the stimulus of intelligent sympathy. Again, he took to journalism, and it was his mainstay through life. During the last thirty years, New York journalism has absorbed much of our best talent, and well it might, for it demands the best. No severer test can be applied to a writer than that of his ability to furnish leading articles regularly. More than one, who has succeeded easily as a bookwright or essayist, has found his equipment and his power of composition inadequate to the off-hand production of compact, polished, well-informed leaders, such as are needed for the editorial pages of our great newspapers. Journalism is an art; but under our system it brings little beyond his weekly stipend to the sub-journalist. The stipend is sure, and that means a great deal to one who lives by his pen. Newspapers thus far have supplied the readiest market to a writer, and the magazines next to them. In a chapter upon Hood, London's journalist-poet, I have claimed that the task of daily writing for the press, while a good staff, is a poor crutch; it diffuses the heat of authorship, checks idealism, retards the construction of masterpieces. Besides, it brings an author into attrition with members of the craft who possibly know him so familiarly as to underrate him. He is subjected to local jealousies, to the over-praise of the newspaper which befriends him, and sometimes to the unjust or ungenerous treatment of rival sheets. All this may be thought an evil peculiar to New York, and one which we shall outgrow. But the same phenomena are visible in the matured newspaper-life of the capitals of England and France, and must be accepted as part of a journalist's warfare and surroundings.

Newspaper-work, then, to which Taylor owed so much of his current reputation, also restricted his advance as a creative author. He always was compelled, by this and by lecturing, to hold the popularity he had gained, and to obtain the means of carrying out his scheme of life. As a man of note, his

home-pride grew upon him. He chose to realize a dream of possessing a sightly house and broad acres in Kennett,—a manor-home where he could place his parents, and find a retreat in times of rest. All this he did, in his early prime; such a man can have anything for which he will pay the price. Its cost to him, no doubt, was a lessening of his quality as a poet. Even in 1854 he had begun to lecture, and the practice became a lucrative source of income. Like journalism, it broke up his art-life, which was renewed at unfrequent intervals. A pressure of social and professional duties—meetings, speeches, correspondence—soon bore upon him severely. Under it he made a good fight; hopeful, generous, considerate, trying to do something in a field where the laborers were too few. How gladly would he have exchanged it for one of thought and imaginative work! But men do not escape from tasks they once assume, and he had undertaken to earn a large income and survey the world, on the one hand, and to hold the Muse by her pinions on the other. His poetry had to be composed “between spells” and on the wing; more than all, the versatile habit of his life became a second nature to him.

One need not dwell upon the desirability of calm and seclusion for the production of the best literature. With individuals, as with nations, stirring periods of action are not favorable to idealistic art. There is much unfairness, however, in the blame to which public men in this country are subjected for their overwork. This is rather a matter of necessity than of choice. People in the old world largely inherit their means and methods from their forbears; new men, even there, often have the habit of overwork fixed upon them by the time their footholds are secured. But the statesmen and thinkers of Europe start with assured incomes more commonly than do our own, and are not forced to earn their bread as they go along. Our Wilsons, Evaryses, Curtises, have had to consider first the means of living, and to be statesmen or writers in addition. Our Eastern Brahmins, happily, have had for the most part resources which they have enlarged by the help of such gentle, scholarly pursuits as the service of a university affords. They have shown themselves quite willing to indulge a spirit of restfulness and calm. So long as Americans who do not inherit estates have the Anglo-Saxon pride and domestic tenderness, they will be tempted to do work elsewhere than in a garret, and rarely

be able to drive from their minds the thought of its effect upon an income-paying constituency.

II.

SOME years of Taylor's life now were occupied with travel in Europe, north and south. He married in Germany, and his choice was most fortunate. She whose hand he gained was by her talents and acquirements in every sense his helpmeet,—honoring his genius, in full sympathy with his purposes, for happy years the wise and tender guardian of his household, as she is now the faithful treasurer of his memory and fame. Her translations made his works known to her countrymen; she confirmed his taste for the thought and letters of the Fatherland, and was his constant aid in the study of them.

“The Poet's Journal” was an expression of the happiness for which its author had now exchanged the trials of the past. His bride won and brought to America,—his Lares established in the mansion he soon completed in Kennett,—this poem was the record of past and present feelings. It opens the collective edition of his verse; is a series of lyrics, going through the range of his emotional experiences, and has many touching passages; but to the critical reader, its chief interest is found in its revelation of the author's heart. The prelude, to the mistress of Cedarcroft, is not excelled by anything which follows. Years afterward, he made a still more earnest avowal of his wedded content, in the fine tribute which closes one of his ripest poems:

“With thee was the ceasing of sorrow.
 Hope from thy lips I have drawn and subtler
 strength from thy spirit,
 Sharer of dream and of deed, inflexible conscience
 of Beauty!
 Though as a grace thou art dear, as a guardian
 Muse thou art earnest,
 Walking with purer feet the paths of song that I
 venture,
 Side by side, unwearied, in cheerful encouraging
 silence.
 Not thy constant woman's heart alone I have
 wedded;
 One are we made in patience and faith and high
 aspiration.”

The poet now had a companion in his wanderings. It was not his lot to rest at home; his life of travel, writing, lecturing, means-providing, went forward busily. Duties and honors grew upon him. His patriotic interest in the civil war gave birth to some ringing popular ballads. Shortly

afterward he became our Secretary of Legation at St. Petersburg. We need not follow his public career, nor his periodical returns to the shade of his own chestnuts and tulip-trees. His friend Aldrich compares Taylor's life to a drama, of which the intervals were filled with the music of his poetic work at home. Four-fifths of this he was to enact, and we thought to see his mind's "noblest offspring" with the last; but the curtain fell abruptly, and with the putting out of the lights ended a career that steadily had grown in worth. What there was of it was marked by rare experiences. Among his friends, he counted the wise and gifted of many lands, the most noted people of high and low degree. He had their respect and confidence; and his correspondence with them was most extensive. To know the men he now knew—the world's choicest spirits—was of itself a liberal education. His own letters were delightful, and a sheet covered with his beautiful handwriting and flowing thoughts was a thing to prize and store away. When his biography shall be written, it will be seen how superior his private letters, unrestrained in their fact and fancy and criticism, were to those which he gave the press.

From this date his prose-writings became more sustained. Partly with the thought to try his hand—like Goethe, whom he now began to take as a master—at every kind of work, and partly as a form of literature suited to the times, he essayed novel-writing. His novels sold well, and seemed to hit the average taste. They mostly are realistic transcripts of what he had seen, and contained his own views of what was, and what was lacking, in American life at that time. The plot of "Hannah Thurston" is nothing; the tale was written to illustrate types of character and phases of society,—especially to show up the mock-reforms and isms of the day. The heroine is a Quakeress, admirably drawn, as good and original a creation as is to be found in the whole course of these novels. The hero, like most of their heroes, is something of a muff. Taylor's second novel, "John Godfrey's Fortune," has commonplace and unattractive New York scenes, but these are truthful records of the side of life with which the author first became acquainted in the growing city. "The Story of Kenneth" is the cleverest and most artistic of the series; a romance of the old-fashioned kind, and a true idyl of Pennsylvanian country-life in the early prime. Compared

with it, "Joseph and his Friend," the fourth novel, seemed to many people a failure. Meantime, the author's short stories, contributed to magazines, were always fresh and good, as indeed were all his miscellaneous essays. The amount he threw off was remarkable. He wrote prefaces, edited books of travel and biography; did everything a man of letters could do, with equal care and facility. His prose was real prose, simple, clear, good English, if not great. Upon the whole, his literary criticisms seemed to me the ripest and most valuable portion of his prose labor. In them he was compact, learned, writing to the point, and his opinions were just and good with regard to both the spirit and technique of a work. In his later years, his reviews were so catholic, sound of canon and informed as to detail, as to be models; and it became evident that he could have been a great critic, had he devoted himself to criticism alone. He had abundant humor, and this, with his judicial faculty, and his unique talent for parody and burlesque, found charming play in the serio-comic papers which were collected a few years before his death, in a volume called "The Echo Club." So good are its imitations of modern poets that this book takes rank with the "Rejected Addresses,"—so good, in truth, that upon reading the prose dialogue which connects them, we are not surprised to find it made up of some of the most wholesome, kind, and alert criticism that has appeared in recent times.

Few men, not excepting Lewes and Carlyle, have been so well informed as Taylor with respect to German literature. His twelve lectures upon that subject, recently issued from the press, were prepared originally as a university course. For years he was a student of Goethe and Schiller, and their times, and it was the dream of his life to write their biography. To this end he made extended researches in Germany, and collected material under peculiarly auspicious conditions. Had he lived to complete such a work, it would have been a masterpiece. In the midst of his labors, he was enabled to make a complete English translation of "Faust," in the original meters, and to supervise its publication.

III.

THE surprising rapidity with which the two parts of "Faust" were brought out, the original commentary and notes, the avowal that the editor had read all the translations

and commentaries made in any language, were phenomena of that kind which sometimes led people to distrust the thoroughness of Taylor's work. The scholarly character of this performance is now well established. That to which more than one of his predecessors had given a life-time, he apparently completed in three years. He had borne it in mind, however, for two decades, and it was his habit thus to prepare for a work until able to execute it at a dash and with great perfection. Fortunately, the appearance of Brooks's version of the First Part of "Faust," in 1856, had made him postpone his own; when he finally wrote the latter he was equipped by the further studies of many years.

The result was an advance upon any previous rendering of the entire work. It is the standard translation at the present time. The preface demonstrates that poetry sometimes absolutely requires a retention of the original meters for its translation. Illustrations of this are found in Freiligrath's perfect transcript of Scott's "Come as the wind comes," and in Strodtmann's equally fine "Es fällt der Strahl auf Burg und Thal,"—the "Bugle-Song" of Tennyson. To me these seem extreme cases: in others the result might be otherwise. A translator must choose the best method for the work in hand.* It is doubtful whether the test would apply equally well to each of several poets who differ among themselves as widely as Homer, Theocritus, and Pindar.

The characteristics of Taylor's "Faust" are sympathetic quality, rapid poetic handling, absolute fidelity to the text. Now and then his realistic version of the first part has an unusual or quaint effect, detracting from its imaginative design. Hence some of the best portions are those not in rhyme, such as the Cathedral scene, where Margaret is harassed by the Evil Spirit:

"How otherwise was it, Margaret,
When thou, still innocent—"

which is reproduced with thrilling power. The regular verse also is well rendered, Goethe's "Dedication" never having been so well given by any other translator. Its firm, sonorous stanzas are in harmony with Taylor's own manner and poetic feeling:

* Mr. C. Kegan Paul's subsequent translation of the First Part, also upon the lineal and literal plan, and adhering to the original meters and order of rhymes, has qualities which have secured for it much attention.

"Again ye come, ye hovering Forms! I find ye,
As early to my clouded sight ye shone!
Shall I attempt, this once, to seize and bind ye?
Still o'er my heart is that illusion thrown?
Ye crowd more near! Then, be the reign assigned ye,

And sway me from your misty, shadowy zone!
My bosom thrills, with youthful passion shaken,
From magic airs that round your march awaken.

* * * * *

"And grasps me now a long-unwonted yearning
For that serene and solemn Spirit-Land.
My song, to faint Æolian murmurs turning,
Sways like a harp-string by the breezes fanned.
I thrill and tremble; tear on tear is burning,
And the stern heart is tenderly unmanned.
What I possess, I see far distant lying,
And what I lost grows real and undying."

To the mystical and much disputed Second Part the literal and lineal method of translation is specially adapted, and serves to preserve the fantastic nature of the original. Herein Taylor had the gift and knowledge which enabled him to succeed where others had failed. He felt his ability, and perhaps too readily estimated the greatness of this part by the difficulties he mastered. The best poet, other things being equal, is the best translator: witness the contemporary blank verse Homers—of Bryant, the poet, and Lord Derby, the learned amateur. Opinions may differ as to the merits of Taylor's handling of the First Part of "Faust," but with respect to that of the Second there is little question. It is unlikely that any great English poet soon will undertake to excel it. Swinburne could make the venture, were he sufficiently a German. Carlyle would have made a noble translation, for he is essentially a poet, despite his outcry against verse. Shelley, had he essayed a complete version and made his studies accordingly, might have left us the ideal translation—for he was the ideal translator. His paraphrase of the "Hymn to Mercury" is, as Emerson would say, more original than the original. His overture of "Faust" is in some way more grand and rapturous than Taylor's. His lines breathe the very spirit of that "astonishing chorus" of archangels. His "Walpurgis Night" is full of enchantment—too soon the waving ended of that magic wand.

Taylor's notes and commentary are the best we have, learned and intelligible, equally marked by poetic feeling and good sense. His critical views of the Second Part should be more authoritative than those of others less conversant with the subject and less truly poets. He approves of Lewes's

statement: "I have little sympathy with that philosophy of art which consists in translating Art into Philosophy, and I trouble myself very little with 'considerations on the Idea.'" In disputed passages, he seeks for light from his master's other writings, rather than from German and English commentators. The result of this course is excellent, and I do not believe that any other translator has so nearly reproduced both the text and spirit of Goethe's life-long work.

IV.

An art-poem, "The Picture of St. John," was published by Taylor some years after the appearance of "The Poet's Journal." His talent for drawing has been mentioned; he was exceedingly fond of art, and not a few of our best-known painters were his chosen and attached friends. The new poem was dedicated to this gentle brotherhood,—to the lamented Kensett; to McEntee, the studious and pathetic interpreter of our autumnal skies and woodlands; to S. R. Gifford, lover of golden skies and falling streams; to Eastman Johnson, Church, and Colman and Whittredge. The theme may be termed the development of an artist's powers through experience of the joy and suffering of life. The tale is Italian, as regards both feeling and incident; and the scene is laid in Italy and the Alps. There are four books, of stanzas which seem a variation upon the *ottava rima*. The poet spent much time upon this work, and it has many graceful passages. But as a fresh and original conception and a charming piece of workmanship, I should prefer "Lars," the only sustained poem in narrative form which he subsequently composed. This was written about five years before his death, and I was surprised at the comparatively slight attention which it received. It is in pure and even blank verse, and is a finely conceived poem, executed in a style worthy of the conception—which could not always be said of Taylor's works. In "Lars" he took a subject quite within his powers, and realized his ideal. In one sense the theme is American; the scenes change from the Norwegian coast to the Quaker borders of the Delaware, and the author thoroughly understood the landscape, manners, and sentiment of the two regions. The atmosphere is, by turns, fragrant with the balsam of Norseland firs, and thymy with the smell of new-mown fields across the western sea. A contrast between the half-savage habit of the Norse-folk

and the placid religious quality of our pastoral midland settlements is strongly and sweetly drawn. The combat with knives between the rival herdmen, Lars and Per, is a virile piece of work. Less Tennysonian and even more poetic are the idyls of Norwegian cottage life, which precede this scene. The poem is a delightful production; we have no idyl of similar length, except "Evangeline," that equals it in finish and interest. It belongs to the school of Tennyson; but "Evangeline" likewise had a model, and had the advantage of seeking popularity at an earlier time.

A subsequent collection of miscellaneous pieces—"The Home Pastorals," to which I have referred—was made by the poet. Four contemplative poems of the seasons, as observed from the porches of Cedarcroft, are exquisite of their kind, and have been undervalued; they are in English hexameter verse, for which Taylor had a good ear, and only narrative pieces in that measure obtain a popular reading. To me they seem wise, beautiful, true to nature; resembling in ease and freshness Clough's "Bothie," and very faithful to the scenery and sentiments of the Pennsylvanian border, where

"North and south are as one in the blended
growth of the region,
One in the temper of man and ancient, inherited
habits."

I bespeak a new examination for the series. This book also contains some of the poet's best ballads; but has other lyrics quite uneven in merit. It is notable for three of the odes (exhibiting his taste for sweeping Pindaric measures) which he recited upon various public occasions in his later years.

Here it may be noted that Taylor, in some respects, though hardly in essential quality, bore a certain resemblance to Lowell. The likeness pertains to their poetic powers, themes and methods. Both poets have been varied in mood and range, have excelled in dialect-verse and in spontaneous flights of song. In the poetry of each is seen a tendency to moralize. Lowell's process of thought is the more suggestive and subtle of the two. Taylor's measures never are rugged; Lowell's often are, but the latter has sudden felicities peculiar to himself. Both have written with facility, and declined to revise their work. Frequently, in recent years, each was called upon to write and deliver odes—of which the measures have a family likeness, irrespective of their authorship. Taylor's Gettysburg ode, for the dedi-

cation of the National Monument, and his Goethe ode, are manly and heroic poems. The Shakspeare ode is less successful. In a crowning lyrical effort, he had as wide an audience as poet could desire. He was addressing not only the assemblage in Independence Square, on the 4th of July, 1876, but millions of his countrymen,—in truth, the reading world. It was a fine occasion, and all his ambition was aroused. What poet ever had a more historic opportunity? Should the verse of all his contemporaries be forgotten, as is not unlikely,—a century from now, and perhaps for centuries thereafter, the first Centennial Ode will be revived and re-examined.

“The National Ode” was not unworthy of the occasion, from a conventional point of view. It was sonorous, patriotic, mindful of our traditions, full of dignity and rhetorical power. As such it was received. But it was not the one new, bold, original production, which appeals alike to the wise and the unlearned, rouses the imagination, imprints itself upon the memory of all who read it, and becomes a lasting portion of national literature. Marvell’s ode “On the Return of the Lord Protector,” and Lowell’s “Commemoration Ode” are poems of this kind; in sooth, Taylor’s effort, coming after the latter, demanded all his courage. A friend urged him to adopt some regular stanzaic form, however complicated, or else to write his poem in blank verse or rhymed-heroic,—either of these measures being more likely than the irregular Pindaric to touch and hold the popular heart. It was added that the simplest vehicle would best convey, on such an occasion, the noblest thought. I suppose that his adverse decision was guided partly by precedent, more by his instinctive sense of an-ability to compose and recite musically his Pindaric verse. He did deliver his ode with superb effect, and felt the occasion in every fiber of his mold. Americans refer without distrust to this poem, issued in so many forms, but few recall its phrases; and it must be acknowledged that one only of Lowell’s elaborate odes really has succeeded in fastening itself upon the public mind.

v.

ONE more division of Taylor’s manifold productions remains for consideration,—to wit, his dramatic works. Of these, two are philosophical studies cast in dramatic form; the intervening one, however, is a five-act play, the interest being human rather than

speculative. This I will look at first, and separately.

“The Prophet: A Tragedy,” has certain claims to attention. This work, a closet-drama perhaps as easily adapted for the stage as one or two of Browning’s, was an honest attempt to treat dramatically a modern and peculiar American theme, and to make what could be made of it. Hints are taken from the early history of Mormonism, but the central figure, instead of being a vulgar impostor like Joseph Smith, is a simple and pious young farmer, such a man as Taylor’s own country might have produced; intelligent withal, but the victim of the religious ecstasy that comes to one without knowledge of books and the world. The devices of shrewder comrades and the jealousy of women unite to deceive him, and to persuade him, by signs and miracles, of his own prophetic mission. The incidents follow naturally; the scenes being laid first in New England, then in the far West, whither the Prophet and his followers have gone to found a sacred city. Internal plots and external foes bring about a catastrophe, ending with the death of the hero of the play.

The highest form of poetry is the drama, for it includes *all other forms*, and should combine them in their greatest excellence. At its best it is the supreme flower of the literature of any nation, and demands the poet’s rarest and most comprehensive genius. It scarcely proffers a method which he can fully master, late in life, after years of lyrical or idyllic minstrelsy. The dramatic instinct must be born in him: again, his formative period must find him in a region where a dramatic tendency already fills the air. Otherwise his work as a playwright, like that of Tennyson or Longfellow, must be accomplished by an artificial effort, and will lack the touch that makes the whole world kin. Even Browning, with his immense dramatic resources, early found a greater hindrance than his own subjectivity in the non-sympathetic spirit of his people and time. But I shall not here discuss the present condition of dramatic feeling in our own country, nor the omens of the future. These are matters for separate consideration. “The Prophet” failed, in view of its author’s theme and purpose, not solely from his lack of early dramatic practice,—his way of feeling and expression always having been in the reverse direction,—but from causes which hardly could be overcome. Such a plot might be treated idealistically,

by giving the widest range to imagination, fearing no extravagance, creating one's own facts and atmosphere, and the result might be a great dramatic poem if not an acting drama; or it might be treated realistically,—the course which Taylor naturally pursued. To insure success by the latter mode, the time and events of a drama must be poetic in themselves. In this story of our own time, there is, perforce, a lack of the illusive and entrancing atmosphere of the far-away past. That which is too modern and familiar seems commonplace. The time may come when as much shall be made of the Mormon episode as of the traditions of the Druses or of John of Leyden; at present it furnishes a store of clap-trap to melodramatic playwrights who derive from it substantial gains.

Taylor drew his personages with skill, but their simple and unheroic character was against the passion of the play. The work illustrates the importance of certain canons. First, nobility of theme has much to do with the value of art; secondly, realism is not the chief end in matters of design. There is truth—and truth; the truth of what is or has been, and the truth of what may be. While the dispositions of the two women, Rhoda and Livia, are finely contrasted, the tone of the whole play is purposely restrained,—too much so, in my opinion; the general style is bald, prosaic even in the people's hymns and songs. Aldrich suggested the theme to his friend as a good one for treatment; and, with all its lack of freedom, this play as a literary work is far more worth attention than such a *romanza* as the "St. Abe" of Mr. Buchanan,—which had a wider reading when it first appeared.

The lack of interest felt in "The Prophet" deterred Taylor from further experiments of the kind. His other dramas, therefore, were purely ideal. "The Masque of the Gods" presents that side of his nature which was most exalted and aspiring. His religious temper, it has been seen, was bred under other influences than those which restrict the faith of many poets. He was a believer in direct inspiration, but a questioner of revelation. The creed of the Progressive Quakers was liberal and humane, and the boy grew up to regard men of all races as his brethren, and every form of worship as acceptable to an Unknown God whom he himself addressed in the spirit of Pope's "Universal Prayer." This sense was strengthened by his travels and studies,

and his religion became broader than any man's theology. "The Masque of the Gods"—a title with a tinge of quaintness below the dignity of the subject—is a drama of three dialogues, managed in a severe and classical fashion. The personages are all those greater deities whom men have worshiped in the historic advance from barbarism to Christianity. First, the Rocks, Caverns, Serpents, Wolves, the Mountains, the Rivers and the infinite Sea, discourse among themselves. They are followed by Brahma, Ormuzd, Manito, Baal, Apollo, Jove,—even by Elohim and Immanuel, the Gods of the Mosaic and Christian dispensations. The motive of the sublime dialogue is a recognition by these majestic divinities of a God beyond and above them all, of whom they are but the servants and the successive types. Such a poem might have been written in one language or in another. It is abstract, universal, not in any sense a home production. Of course it would find a limited reading. Yet it is lofty and pure, written in blank verse with lyrical interludes, on a sustained key, and more compact than most works of the kind. It approaches as near to the highest grade as intellect and eloquence can lift such a poem. What it lacks is the unconscious flight into that empyrean where the wings move without sound and touches of flame hover at the tips of the pinions. The conception is vast, daring,—far more imaginative than its working out.

This drama, which Taylor rated high among his productions, and which is in every sense an expression of his devotion to the nobler forms of song, renders it possible for one to assert that a writer may be judged somewhat by his ideals, and that, so far as this mode of judgment is concerned, its author held a significant place in the group of American poets. It was the precursor—the overture, we may say—to the work that was his "swan-song," the larger drama which he lived to complete, and of which a fair broad copy reached him but a day before the lyre dropped from his hand forever. "Of his last work," wrote his bereaved wife,—"*sein Schwanen Gesang*, as I call it,—as I would call it in my mind involuntarily, long before I knew he was deadly ill, he only saw one copy, and that of the English edition."

A strange interest belongs to the drama of "Prince Deukalion." The poet deferred his serious work upon the life of Goethe, that he might be sure of completing this one

onal compeers. His gift was genuine and inherent, but it speedily became too much diffused; he strove to survey too large a precinct, and it was surprising how far, in more than one direction, he made his lines extend. With all his facility and purpose, he found himself in a too arduous struggle between the duty of the hour and the still higher work fashioned after "the pattern which was shewed him in the Mount." He bravely set himself to carry out an almost impossible plan of life. His manliness in this and other respects we all concede. If he hesitated to boldly follow his poetic instincts, his courage was absolute in the expression of convictions, and in reliance upon his own energies for all he got from the world. During his experience of a time and region which made Poe a weakling,—almost an Ishmaelite,—with what pluck and heartiness Taylor faced the situation, until it seemed as if the very god of strength took pleasure

in befriending him! After all, he had some right to count upon length of years, and to shape his plan accordingly. He grew in taste and judgment as he grew older, and even his devotion of so much time to hack-work was not without its requitals. He led a singularly happy life throughout, and the cloud foretoking its close was but of brief duration. He was fond of festivals, of joy; he "warmed both hands before the fire of life." More was given to him than was taken away, and his memory is something to dwell upon with pleasure, not with pain. The volumes of his song are left to us, the bequest of that which he thought the choicest product of his years. No one who would acquaint himself with American poetry can overlook Bayard Taylor's share of it. Those who would understand its growth, or predict its future, must bear in mind the generation for which he wrote and the story of his efforts and environment.

UNDER HIGH PRESSURE.*

SAMUEL BREEWOOD came out of the Massachusetts Institute of Technology with the highest honors. Some of his friends, it is true, had regretted that he was not a Harvard man; but he was at all events a man who knew the use of tools. He had no Greek and little of the classics, but he was theoretically master of the steam-engine, the machine lathe, the rock-drill, and those noble and ancient tools—the file and hammer; moreover, he had learned the use of those finer tools—the brain, the eye and the hand; and though practically he knew little of real work, he said to himself that he would soon bring his theory to the level of practice.

For a few weeks after leaving school he looked about near Boston for something to do, and found that the world somehow seemed already too full of engineers. To make a moan over this, after the manner of some who find their market over-stocked, was not in his nature. He recognized that to begin he must begin, and after some search he at last obtained a place as clerk of the High Bush coal-mine at Emberton City, Pennsylvania.

To one brought up in the rarified intellectual atmosphere of Boston, Emberton City seemed stifling. The raw, straggling town,

the squalid poverty of the mining population, the ill-made and inefficient machinery employed in the mines, and, above all, the ways and manners of the people, depressed him. He wanted to reform and improve everything in sight, from the miners' huts to the manners of their sons and daughters. Being wise, he did nothing of the kind, and contented himself with his clerical duties of keeping the accounts of the out-put of the mine and the wages of the men. He was an engineer, doing a clerk's duty, but he would bide his time till something more congenial offered.

He had taken lodgings with a widow woman named Baumgarten, who had one daughter aged nineteen. This place was the only one that had offered, and he had taken it on impulse.

To this *ennuyé* young man, not without certain disheartening experiences of "society," Maria Baumgarten seemed more completely a woman than any he had ever seen. He said to himself in an extravagant way, that he had not met a young woman before, but merely cultivated young persons of feminine aspect. She appealed to him with a vivid intensity and an open-air freshness that were entirely new to him, and it was not without an occa-

sional feeling of surprise that he came to acknowledge a more decided feeling of genuine preference for her than he had thought again possible to him. How those young ladies he had known in Boston would have smiled had they seen him carrying her hymn-book as they walked on Sunday morning to the little wooden church, apparently well pleased to accompany a girl absolutely without "views" or "kulture!" She could cook and sew, and these operations did not seem to impair her very decided beauty. She seemed to express life and high spirits and intense womanliness, as if it was a good thing to have limbs, to be able to run, to walk, to laugh and be alive.

To Maria Baumgarten, the Eastern man, with his thin, delicate features and quiet manners, seemed a new revelation. The ruddier sons of her native mountains lost their charm, and gradually she came to have nothing more to do with them. Rumor said that one of her lovers, a fine young fellow named Krumburger, employed in the High Bush pit, took it greatly to heart.

Weeks passed and matters progressed, and one March morning they came to a sudden climax.

It was Saturday morning, about twelve o'clock, when Breewood looked up from the High Bush company's ledgers and gazed round the bare, whitewashed room that constituted the company's office. The sanded floor, the ugly stove, the coal-dust covering everything, the grimy windows, seemed to fall upon him as a blight, a numbing weight of unloveliness. Through the window he could look out upon the mountain-side, torn and half denuded of trees; the enormous coal-breaker, black and hideous in the sun-shine; the vast heaps of coal-dust, the tangled skein of rude railway tracks, and, above all, the pit's mouth, a dark spot on the white, snow-clad mountain.

Suddenly, he heard the steam-whistle at the engine-house blowing furiously. The engineer must have mistaken the hour: it was not yet noon. While thinking of this, he saw a man running down the tracks toward the town, and, at the same time, noticed puffs of steam from the engine, as if the hands were at work dragging up a load on the trolley, a car that ran up and down the pit. Something unusual had evidently happened.

Breewood closed the books hurriedly and went to the door. The man came toward him, shouting and waving his arms in a frantic manner. As he ran past the door, he cried out:

"Sweetbriar has bu'st inter High Bush. The mine's floodin'!"

Hastily locking his office, Breewood ran like a deer over the snow-covered tracks toward the pit. In a moment he saw an engine drawing out of the breaker with a train of loaded cars, and he gave the signal to stop. By the time he met the engine it had stopped, and the engineer leaned out the window to see what was wanted.

"Take off your cars and run down to the station and telegraph to Pottsville for the superintendent. Say Sweetbriar has burst in, and order up two steam-pumps and a thousand feet of two-inch pipe and as much four-inch with couplings. Then bring your engine to the pit as soon as possible."

That the clerk should give orders in this manner puzzled the engineer, but he accepted the commission and quickly cast off his train and went flying down the crazy track at full speed.

By the time Breewood reached the breaker, its dizzy stair-ways were swarming with men and boys pushing and struggling to get up to the top floor, where they might take the high-level bridge to the pit's mouth. He had to take the longer path up the mountain, and by the time he reached the pit there was a frantic crowd of men swarming into the engine-room and about the huge black hole where the steep railway led down into the lower darkness of the mine. These mines are "on the slope," and the pit did not go down vertically, but at an angle of 45°. Just as he arrived, the trolley, drawn up by a wire rope, came to the surface, and a mingled shout and groan went up from the excited throng of men gathered round the pit's mouth. The trolley and its load made a horrid spectacle. It was choked with men, bleeding and torn, and crowded together in frightful confusion, who had fought in brutish selfishness for a chance to come up from the flood below. The trolley rolled up to the level, and a hundred hands were stretched to rescue them.

Breewood went into the engine-house. The place was deserted by the fireman and engineers, who had gone to see who had been saved. Indignant at this neglect in such an emergency, he went back to the door and called for the firemen.

A big fellow, black with coal-dust, shook his fist at him and cried:

"Who be you? Be you the boss?"

"No. But I mean to be. Go back to your work at once and raise more steam."

The man put his hands in his pockets

and turned sullenly away. Breewood recognized that if anything was to be done he must be master. He looked out over the bridge and saw a thousand frantic men and women rushing in terror up the mountain-side. In a moment there would be a senseless and helpless mob, and, meanwhile, perhaps men were drowning in the darkness three hundred feet under the streets of the town. He went out on the platform about the pit's mouth, and springing upon the wooden rail, he shouted, as loud as he could, above the babel of voices :

"Lend a hand, men! There may be more left below!"

There was a momentary hush, and the men turned to see who spoke.

"They be dead," said some one.

"Then we must save the bodies. Come, men, lend a hand and we'll save them."

He would have said more, but there was a loud murmur of discontent. Who was this—this clerk with his fine hands? What did he know about mining? He must be a fool to think any one alive in the mine while the water filled the bottom of the slope.

"Lend a hand, men; we can save them yet!"

A grizzly-headed Welshman took off his hat and said respectfully :

"They be all dead, mister. It's no use doin' a thing."

There were murmurs of approval at this, but Breewood replied promptly :

"The men at the top of the slopes are alive. The air must keep the water away from them."

This remark won instant assent, and he followed up his advantage quickly.

"Come. I'm going down. Who'll go with me?"

A dozen hands were raised, and Breewood jumped down from the rail and took command of the work; and with that recognition that workmen always show to a mind that can lead, they waited for commands.

"Let the firemen go back to the work and get up extra steam. I've ordered up a pump. It will be here in a few hours."

Several men moved away toward the boiler-house, and the rest stood expectant and silent.

"I want a stone-hammer and three young men."

Several men stepped forward and Breewood selected his men, and some one having brought a stone-hammer, they four got upon the trolley and prepared to go down into the pit.

"Count the men, and see how many are missing. Let some of the men go home for their meals, and let a full set of tools be sharpened and made ready for work. Go!"

At the word, the trolley rolled slowly down the steep incline and disappeared in the darkness. Then a hush fell upon the crowd of people gathered round, and they waited in silence till the signal should come up from below. Women and children were arriving from the village every moment, but they seemed awed into silence, and stood waiting for news. By that curious instinct that affects such crowds, they felt sure that some were still in the mine, but who or how many, or whether dead or alive, they could not say.

Ten minutes later, the signal-bell rang and the steel rope began to creep up the slope. Instantly the crowd pressed nearer to get a view of the rising trolley. Suddenly the bell rang to stop and a painful silence fell on the people. Then a woman began to sob, and then another, and in a moment several were crying.

"Whist! woman!" said one to another. "Your man be all right. He's a-bossin' the job."

Then the bell rang again. The engine turned swiftly and silently, and in a moment the trolley rose into view, and the crowd struggled closer to get a view of its occupants.

Breewood was standing on the edge of the car, and as it came to the surface he said :

"They're alive! Volunteers to the rescue!"

A wild shout of joy went up from the vast throng that had gathered round the pit, and a hundred voices suggested this thing and that, but Breewood held up the stone-hammer and commanded silence.

"We knocked and they replied to us. They are caught in the top of a slope. We must cut them out."

A dozen big fellows armed with picks stepped forward, eager for the work.

"Hold on, men. We must have a stage built first to work from, and a place for the pumps, for the water is rising fast."

"Oh, they'll be drowned, they'll be drowned!" screamed a woman in the crowd.

"No, they wont. They are perfectly safe till we reach them."

These words calmed the woman and prevented the infection of excitement from spreading, and Breewood called for carpenters and a load of heavy timbers.

"Who are the missing men?" he asked.

"Dennis Nagle, John Smith and John Krumburger," said a voice in the crowd.

A momentary flush of color spread over the young man's face, but he turned quickly away and hid it from them.

Timbers were quickly gathered and loaded into the trolley, and two men with heavy axes got in on top of the load. Breewood borrowed a foot rule from one of them, and carefully measured a length of rail on the railway. An old man who watched him said:

"The last rail is a half one, sir."

"Ah! yes, thank you. I was measuring the distance from the top of the pit. I counted the rails we passed. One hundred and sixty-eight feet from the top is the place for the stage."

"Yes, sir; and one turn of the winding-drum takes you down twenty-eight feet.

"Good! That's just the information I want. Go tell the engineer to let us down six turns."

"That I will," said the old man. "It's my son what's down there."

"We'll have him up by to-morrow or next day."

"I hope to God ye will. Like as though he'd starve atween whiles."

"I've thought of that, and I mean to send food to him as soon as possible."

"The like o' that will not be easy. But ye be a boss miner—I can see that."

Breewood joined the carpenters on the trolley, and just as they started down he addressed the crowd of people that swarmed about the pit's mouth, and said that the lost men would undoubtedly be recovered, but probably not for several hours. They had better disperse and wait quietly at home. But the people would do nothing of the kind. Some few returned to the town below, but it was only to bring up food to those who remained.

The trolley slid quickly down the slope and the crew were soon in the dim light from the oil-lamps on their caps. Suddenly the trolley stopped. Breewood sprang out upon the steep road-way with the stone-hammer in hand, and struck three hard blows on the black wall of coal that formed that side of the slope. They listened intently, but there was nothing, save the appalling silence of the mine, the dead, lifeless silence of the earth one hundred and seventy feet below the sod. Then he knocked again three times, and they listened in breathless attention. Were the men already lost in the darkness and the rising flood? At last there were knockings,—faint, indistinct, confused; a

strange call for help through fifteen hundred feet of solid coal. The men were still alive, imprisoned by the water at the top of some slope.

"Seems as if they were telegraphing," said one of the carpenters. "That Dennis Nagle worked in the telegraph office at one time."

"You're right. It's Morse's alphabet he is using. We must have the operator down here and then we can speak to them. Now, men, rig up a platform here for the steam-pumps. Make it the whole size of the slope and very strong."

The men sprang to the work quickly. It was a case of life and death, a rescue from the rising flood in the mine. The moment the trolley was unloaded, Breewood pulled the signal rope and went up the slope, leaving the men to make the platform. At the pit's mouth the people stood ten deep, eager and anxious to hear news from the imprisoned men below. Breewood called for volunteers, and at once selected six bosses and bade them make up gangs of men to work in relays of four hours each. While the bosses were selecting the men, Breewood went to the engine-house and called the blacksmith and master mechanic.

"We must have a drill eight hundred feet long," he said, and then, with a pencil on a board, he sketched out full working plans of an original piece of engineering construction. He also made rough plans for two wooden air-locks of novel construction. All this work took more than an hour, and in the meantime the news of the disaster had spread over the country.

A messenger had been sent to Emberton City for a telegraph operator, and in a short time a young girl was announced as the only operator within reach. Though only a child, she bravely consented to go down the pit.

A reporter of the New York "Herald" also appeared and began voluble questions concerning the disaster and possible rescue. Breewood shut him up with decisive vigor.

"Lives depend on our work. We cannot be disturbed. You shall have every chance to see, but you must not talk to the men."

The reporter retired within himself and considered the matter:

"A GREAT DISASTER.

THREE MEN BURIED ALIVE.

SCIENCE TO THE RESCUE.

SPLENDID TECHNICAL ABILITY AIDING HUMANITY."

That was the way he put it in "displayed capitals" in his own mind.

"I'm not a scientific man, but I can observe and I can dig."

With that he rushed off and telegraphed for help,—a scientific writer,—and twenty minutes after, a booky fellow from the home office was crossing the Jersey Central ferry bound for Emberton City. Twenty-five minutes later a dozen men were laying a wire on impromptu poles up the mountain to the pit's mouth. Thirty minutes later, one of the men on Jimmy Brown's gang had sold out his place, his pick and his mining suit and lamp to the reporter for seventy-five dollars.

The trolley rolled up to the edge of the slope, and this time it held Breewood, Jimmy Brown and his gang, and a young girl—the telegraph operator. It went down amid a rousing cheer from a thousand throats and was lost in the darkness of the pit.

The trolley stopped at the platform and they all got out. The platform was finished and even boarded over.

"Now, my girl, you must help us. I'll knock on the wall, and you must listen and see what you can make out."

The girl was trembling and a trifle frightened at the semi-darkness, the awful silence, and the strange glare falling on black faces about her. Breewood took her hand in his and offered her a seat on a plank, and then with the other hand he struck three blows on the wall. The men stood round in solemn silence, listening and wondering what the "new boss" meant.

Again the knockings, so faint and far away that it was almost impossible to distinguish any sound at all! The girl leaned against Breewood and trembled with an undefinable fear. Her lips were parted, and she stared with wide eyes at the lamp on Breewood's cap. Suddenly she sighed.

"Oh! I—I hear them. They say—they—they are calling! 'Help! help! Attention! attention! help!'"

Then she suddenly dropped her head and fainted away.

"This will never do," said Breewood. "Any man got any liquor?"

"I have," said one of the men, pulling out a brandy-flask. Breewood looked at the man sharply and some of the others laughed, but no comment was made, though the reporter had most foolishly shown himself. Breewood took the flask and forced the girl to swallow some of the liquor, and the

carpenters offered some water in a tin mug. By a little effort they revived her.

"You must not be frightened, my child. You're perfectly safe."

"Yes, sir. But the men in there! It is horrible."

"So it is, and everything depends on you. You can help us save them. See! we can tap on the wall and talk to them."

Breewood made a motion as if striking the wall of coal with the stone-hammer.

"Give me the hammer and I'll speak to them."

The men instinctively broke into a cheer, and the girl smiled, blushed, and bravely stood up and began pounding on the wall. Then she paused and listened, and instantly came the faint, murmurous knockings. The girl did not speak, and in a moment she began to strike the coal again, in curious strokes, long and short. Then the far-away sounds began again and continued for some time, while the girl stood with her ear at the wall, listening intently.

"They say they are caught at the top of the third slope. There are three of them. The water has shut them in and——"

The knockings began again, and in a moment the girl said:

"They want the inclination."

"They want the pitch of the slope, the new drift, so as to work toward us," said Jimmy Brown, the gang boss. "It will be a fall of nearly one in ten, I reckon."

Breewood bade the girl send word that they would cut them out as soon as possible, and would descend about ten feet in a hundred. The exact pitch would be given as soon as possible.

"Now, men, to work! Drive a heading about three feet wide and five high."

"That's too big," said Jimmy Brown. "We'll be a week getting through."

"No, because the spoil must be passed up from hand to hand."

"Aye, ye be right. Come, lads! To the rescue!"

Two of the men raised their picks to strike, and the instant after the coal was spattering about on the platform floor. One of the carpenters raised a plank to make a hole to throw the spoil down the slope, for there would be no time to raise it by the trolley, and the others, with Breewood and the girl, got on board the trolley, and were quickly drawn up to daylight.

As Breewood stepped off the trolley, he was met by the superintendent, furious and insolent. What right had the clerk to order

men and materials about in this extraordinary manner?

"The accident threw everything into confusion, and I took charge of the people, and made preparations to rescue the men below. I will show you my plans and surrender the work to you."

The man doubted if any men were left alive, and preferred to carry out his own plans.

"There are three men caught at the top of the third slope. We heard from them and sent word to them."

The superintendent laughed. Hear from men through fifteen hundred feet of coal! Impossible!

Breewood made neither resistance nor remonstrance to the superintendent's power, and merely explained his plans for the rescue.

"Yes, and supposing your machine works, —and it will not,—the moment you reach the men the air will escape, and the water will rise and drown them."

"Air-locks are provided," said Breewood, and before he could add more, a gentleman, who had joined the crowd of people that had gathered near, said quickly:

"Mr. Superintendent, you will place this young man in charge of the rescue party, and give him every aid in your power."

It was the president of the coal company, who, hearing of the disaster, had come up on a special engine from Pottsville.

Three minutes later, a messenger was dispatched for surveying instruments; the company's engine and a powerful freight-locomotive were brought up the tracks as near the pit as possible. Machinists were put to work upon them to make steam connections with them up the mountain-side, so that they could be used to provide steam for the pumps. The mayor was sent for to call out a police force to keep away the surging mass of people who swarmed about the breaker and pit. Breewood personally laid out the new rescue drift, and, in the presence of the president, showed how the girl operator could telegraph by sound through the coal to the men locked up at the head of Slope No. 3.

By sundown all the work was well under way, and over a hundred men were busy at the immense task laid out by the engineer. The steam-pumps and the pipe arrived from Pottsville and were put in position at the platform and properly connected with the two locomotives. By this device, two extra boilers had been obtained, and by nine o'clock in the evening two enormous streams of water were pouring from four-inch pipes

and rushing in a brook down the mountain-side. The miners, with wedge, pick and hammer, made vigorous progress at the new drift running down through the coal. Men were stationed at short intervals along the drift to pass up the baskets of loose coal and throw it down the hole left in the platform.

Very soon the heat of the steam-pumps and the confined air of the drift became unbearable. Ventilation must be provided or the work would come to a stop.

Breewood was thinking of this as he stood at the pit's mouth, listening to the rush of water thrown up by the steam-pumps. Suddenly, he pushed through the crowd and ran back to the shop, where the men were at work on his new drill. Picking up a piece of four-inch pipe, he chalked a mark for a hole to be drilled in the side, and set a man at the work. To another man he gave a piece of two-inch pipe, with directions to cut it up into lengths, and to join these with elbows according to a pattern that he hastily drew on a board. In an hour he had four injectors, formed of iron pipes one within the other, the larger designed for water, the smaller for air. These he had secured to the discharge pipes of the steam-pumps, placing two at each outlet so as to give the water an equal pipe area at the outlet. The discharge pipes lay on the ground pointed down the mountain, and the interior iron pipes were connected with a two-inch pipe laid down the slope and into the new cut. Within an hour, the new injectors were at work sucking the foul, heated air from the pit, and throwing it out with the water with a dull, roaring sound.

A late and waning moon rose on this scene of intense activity, and thousands of people sat up to hear the news from the pit. Hundreds of men, wrapped in thick cloaks, lined the high-level bridge of the breaker, and watched the firemen plying the two locomotives and listened to the incessant hammering in the machine-shop and the deep, booming roar of the great water-injectors. Over all flashed and flared an enormous bonfire, that had been lighted to aid the men at their work. A tent, not far away, was lighted up, and through the open door could be seen two men writing on an overturned barrel, and dispatching full descriptions of all these scenes to the "Herald."

It was nearly morning as Breewood came out on the high bridge of the breaker and gazed down on the men busy about the two

locomotives doing strange duty on the tracks below. He looked abroad over the mountains, the sleeping town, and the strange, wild scene, and wondered if it was not all a dream to melt away in the morning. Some one drew near.

"Young man, you must have rest. This sort of work is wearing on you. Everything is going on well now, and you must go home and sleep. I will take charge of the work while you rest."

After some urging, Breewood consented to the president's request, and went down the long stairs of the breaker and on down the mountain-side to the deserted town. Here and there were lights, as if some still watched for those lost in the deeper darkness underground and for the heroic souls who toiled to rescue them.

At his own home, he found a light burning and a supper laid for him. He ate a little, and then threw himself upon the sofa and instantly fell asleep.

At ten o'clock he awoke to what seemed a new and fairer day. There was a fire burning brightly in the room, and on the table was an inviting breakfast. Maria sat by the fire, as if watching for him to awake. He looked at her for a moment, and recognized her kind attention to his comfort.

"You are very kind, Maria."

She was startled, and rose and came toward him with a bright blush upon her face.

"Oh! I am very glad you have waked. Breakfast is ready. Do you feel rested? I thought you would like a fire, and—I didn't mean to stay here so long."

"It is of no consequence. I am glad to have your company."

She drew nearer, and he observed a tremulous brightness in her eyes, a half-smiling eagerness to add to his comfort, mingled with an earnest solicitude but ill suppressed. For whom could she show so much feeling? He could but think she loved him. He had thought once, in a general way, of the reception this buxom mountain maiden would meet in the thin air of the Brahmin quarter of Boston. But all doubt or fear on this score was swept away now. He believed she loved him, and he felt sure he could love so fine a specimen of vigorous womanhood.

Immediately after breakfast, Breewood went to his room and in high glee prepared for his day's work. Now he could work, indeed, helped and applauded by such a splendid creature. When he came back, ready to go to the mine, Maria also appeared

dressed as if to go out. Would she like to go to the mine? Oh! gladly, if he would take her. So they set out together. At the door, she took his arm, as he thought, by a natural instinct, and they thus walked through the streets till they came to the open fields outside the town.

It seemed as if all the country side had met upon the mountain. Hundreds of carriages and country wagons were tethered to the fences. An excursion train was discharging a multitude of people, and thousands of men, women and children swarmed over the rough, bare mountain, treading the snow into black mud. The coal-breaker was crowded with men, and there were several tents on the slope near the engine-house. There was also a gleam of bayonets, for the militia had been called out to keep the crowd away from the works. Our hero pressed eagerly forward, and his companion, quite as eagerly, kept pace with him. At the breaker they came to the two locomotives still busy at their new work; but here there was a delay, for the guard would allow no one to pass. Then the men on the engines saw them, and there was a cheer "for the new boss," and the guard gave way, but objected to Miss Baumgarten.

"My friend must go with me," said Breewood.

"Oh, that's all right!" was the significant answer, and they both passed on.

At the pit's mouth they met the president of the company, and Maria was introduced by Breewood as "my friend." The president smiled graciously, but made no comment, and immediately called attention to the progress of the work. The new drift had advanced three hundred and five feet, but the water was steadily rising in spite of the pumps.

Breewood said he would go down the pit at once, and the trolley was signaled and brought up. The telegraph operator came up on it with the men, and they reported that she had heard from the men below, who had appealed for speedy help, saying that they could not hold out much longer.

"Oh!" cried Maria, "it is dreadful to think of them buried alive and in darkness and without food."

"We shall send them food by to-night or to-morrow morning," said Breewood.

"Oh! I hope so, indeed."

Had Breewood been less interested in the work before him, he would have noticed the tears that had gathered in her eyes, but he

did not see them and at once set out for the pit below. Maria drew back at first and then suddenly requested to be taken also. To this he would not consent, and Maria pouted and began to cry in dead earnest. Breewood was vexed, but said nothing, and they parted, he going down the pit and she returning home.

It was a great and notable day in the young man's life. He was the hero and master of the hour. By three o'clock the new drill was finished, and by night the rescue drift had advanced five hundred and thirty-four feet, a decided gain on the first day. So much for a re-enforcement of one man. The men who toiled in the dark and narrow heading, worked with twice the energy when directed by the young engineer.

Still he could not keep away from the town, and he went back regularly to his meals. Maria was all attention, yet, with it all, was a certain tearful anxiety that evidently came from his refusal to take her down the pit. He asked her pardon, and she smiled and said it was of no consequence. He now felt sure that he truly loved her. How could he help it, when she so plainly loved him? Besides, was not his rising fame, now flown over the whole land, sure to win him a home that would be worthy of her?

By midnight, the drift had advanced 709 feet from the slope and downward seventy-one feet, as the drift was sunk on an incline of ten feet in 100. Work was then stopped for the purpose of drilling through the remaining 790 feet to the imprisoned men, in order that food might be sent to them.

The problem was to drill a small hole through the coal to the men below, that food might be sent down to them. The men were caught at the top of a sloping gallery, closed at the bottom by the water, the top of the gallery being below its level, and the water being prevented from rising in the slope by the air imprisoned with them. If now, an opening was made through the coal, the air would escape and the water would rise, and submerge the gallery, and even drown out the rescue party, for they also were below the water-level. No ordinary tool could reach the men, and Breewood had designed and constructed of such materials as were at hand a rock-drill for the purpose. Two switch-frames from the railroad were set up in the drift as a support for a long shaft, carrying a hand-crank and a geared wheel. The gear fitted into another gear on a second

shaft, and this shaft turned the rock-drill. A feeding appliance was rigged up behind the machine to enable the man who tended the apparatus to force or "feed" the tool up to its work. At the end of the drill was the cutting-head, designed to break and crush its way through the coal. To allow for the advance of the drill the driving wheel was keyed to its shaft by a long key. The cutter-head was made of wrought-iron pipe having teeth cut in the end and case-hardened, the teeth being "set" alternately outward and inward, so as to crush the coal as it advanced. This was screwed to the end of a pipe that could be lengthened as the drill progressed, and the combined apparatus made a powerful and efficient boring tool.

The machine was taken in parts into the pit and down to the end of the drift, and was there set up with the cutter-head against the coal. A man was stationed at the crank and another behind, where a timber had been braced against the feed-motion appliance, and with a bar in his hand ready to "feed" or push the drill up to its work.

The men stood ready, silent and grim in the murky darkness. The air-pipe on the floor whistled as it sucked up the air, and there was a pause. At the word from the president, the big fellow turned the crank and the cutter-head began to crush and grind into the coal, tearing and rending its way downward upon its noble errand.

It was terrible work on the men, breaking them down in about fifteen minutes; but as one failed another sprang to his place in an instant. The "Herald" reporter gave out in about four minutes, but that did not hinder him from taking full and careful notes of all that happened. Breewood timed the tool and found that it was moving into the coal at the rate of ninety feet an hour. At that rate, it would get through in about eight hours.

To record every step of this remarkable rescue would fill a book. There was toil, trouble, delay, and it was more than twelve hours before the drill came within twenty feet of the imprisoned men. Breewood was asleep at the time, and a messenger came in hot haste to the house. Maria, who met the man at the door, was all eagerness and joy to hear that the drill had nearly reached the imprisoned men. She would call Mr. Breewood at once.

When Breewood reached the end of the steep, dark gallery where the men were at work, he found a new danger threatening

both the lost men and the rescuing party. The two steam-pumps were lifting 15,000 gallons of water an hour, and still the water had gained on them. It had risen in the slope to within twenty feet of the platform, and was, therefore, over the heads of the rescue party below. The pressure would be enormous, and they must guard against an explosion of air when the drill broke through into the cave where the lost men were imprisoned.

The last length of pipe had a small branch pipe at the side, and on this was secured a pressure-gauge to indicate the pressure of the air in the slope below when the tool passed through. Besides this it had two air-locks or gates to prevent the escape of the air through the drill.

Suddenly the man at the crank fell forward, and the handle slipped out of his hand.

The drill was through! It turned freely in the coal, and the pressure-gauge marked a pressure of five pounds per square inch. The men had been reached, and if they were still alive, food could be sent to them. While the drill was moving, it made so much noise that the knocking could not be heard. For a moment there was a solemn silence in the dark and narrow hole in which these heroes worked. Then came a tapping on the pipe. They were alive! They had found the drill!

Breewood went up to the daylight to get the carriers and food, and was surprised to find Maria waiting with soup, bread and meat for the men. A tin carriage on wheels was loaded with food and inserted in the drill, and one air-lock was opened when it rolled down to the second. The lock behind was closed and the second opened, and then they heard it roll away down to the men below.

A mighty cheer went up from the people who still lingered in multitudes about the pit when the news was sent up that the drill had reached the men. Within two hours, posters were up in every city, from Boston to Chicago, announcing the fact. Extras were published every few hours in all the large cities, and the progress of the rescue was noted by millions of readers.

The discovery of the great pressure under which the men were confined alarmed the president and the mining engineers and experts who had gathered from far and near, and doubts were expressed as to the possibility of bringing up the men alive. Everybody said they would be lost the mo-

ment the pick struck through their prison wall, should the air be released. The rescuers, also, would be exposed to instant death, as they, too, were below the level of the rising water in the mine.

Breewood had but one reply—air-locks! These he had wisely ordered in advance, and when the work was resumed, as soon as the prisoners below had been fed, one of these locks was put in place. A deep slot was cut in the coal all round the rescue drift, and in this was set a stout door-frame. All the cracks were filled with cement, and an air-tight door was hinged to the frame. Five feet lower down a second door was put up in the same manner.

So the hours went on. The relays of men were changed rapidly, and pick and shovel were worked with all the energy of despair. The water was now within ten feet of the platform. Another pump, throwing ten thousand gallons an hour, came up from Philadelphia and was set to work. Still, the water crept higher and higher. Breewood seldom went up to daylight; his meals were sent down to him. Once when he went up, about midnight, he found Maria sitting watchful in the engine-room among the anxious company of officers, engineers, miners, soldiers and reporters, who were waiting for news. There were other women also waiting for news, but they had sons or husbands below. She waited for him and he was glad.

The hours slipped swiftly away. It was day again and then night. The water had gained four more feet in spite of the three enormous pumps pouring a muddy torrent down the mountain-side.

At last word came up. Only ten feet more! A last call for volunteers! This time there was death and danger to be faced. The working party were to be locked in behind the air-locks when they broke through the wall!

There were six miners,—all unmarried men (to save making widows),—Breewood, old Josh Binny, the boss, and the reporter. The president shook Breewood by the hand at the first air-lock, and with his own hands barred them in. It was a moment of intense suspense. The Catholic church bell rang for midnight prayers for their safety. The entire population stood in the streets or on the mountain-side in anxious silence.

With a splintering crash Josh Binny's pick went through, making a hole like a man's hand. Then came a silence. Were

they all dead? There was a slight rush of air, and the rescuers stood in breathless suspense. Then came a feeble cheer through the hole. They were alive! To break out the hole, to drag the men, half dead, through the opening, to carry them up the drift past the second air-lock, took just twenty minutes. Then Breewood closed the wooden air-lock. They were still all under the pressure of the imprisoned air, and under water. Would the air-lock hold while they escaped into the slope?

* * * * *

Slowly the trolley crept up the slope burdened with the saved and savers. Breewood stood erect on the front of the trolley, his face shining with joy and triumph. His love should see his day of success, should

share in his honors. The trolley rose to daylight in the center of an immense throng of people, for it was day once more.

At sight of the rescued men lying pale and feeble on the floor of the trolley, the crowd broke into a shout of joy and triumph. It echoed down the mountain-side, and the people shouted in hoarse hurrahs. Every whistle screamed, and all the church bells rang in sonorous chorus. Here were honors indeed for the young engineer. Every wire in the country was telling his fame to the people.

Suddenly, a woman burst through the crowd of people about the trolley and fell upon one of the prostrate men with a cry of joy, covering his face with kisses and passionate tears. It was Maria, welcoming her rescued lover—John Krumburger.

NATURE AND THE POETS.

THE poets are usually the best naturalists; not only because they are alert and impressionable, but because a true poet is more or less *en rapport* with nature. Yet it is curious to note how our singers sometimes trip in their dealings with her. A prominent New England poet speaks of "plucking the apple from the pine," as if the pine-apple grew upon the pine-tree. A Western poet sings at length of the blue-bird, in strains only befitting some rare songster, like the hermit thrush. When the robin and swallow come, he says, the blue-bird hies him to some mossy old wood, where, amid the deep seclusion, he pours out his song, etc. Not one trait of the blue-bird is faithfully set down. I notice another curious departure from the truth of natural history in a recent poem by a well-known author, in one of the popular journals. A humming-bird's nest is shown the reader, and it has *blue* eggs in it. A more cautious poet would have turned to Audubon or Wilson before venturing upon such a statement. But then it was necessary to have a word to rhyme with "view," and what could be easier than to make a white egg "blue"? Speaking of the humming-bird reminds me that the author of "Fantasy and Passion" has evidently confounded this bird with that curious parody upon it, the hawk or sphynx moth, as in his poem upon the subject he has hit off exactly the habits of the moth and not those of

the bird; or, to be more exact, his creature seems a cross between the moth and the bird, as it has the habits of the one and the plumage of the other. The time to see the humming-bird, he says, is after sunset in the summer gloaming; then it steals forth and hovers over the flowers, etc. Now, the humming-bird is eminently a creature of the sun and of the broad open day, and I have never seen it after sundown, while the moth is rarely seen except at twilight. It is much smaller and less brilliant than the humming-bird; but its flight and motions are so nearly the same that it might easily be mistaken for the other. It is but a small slip in such a poet as poor George Arnold, when he makes the sweet-scented honeysuckle bloom for the bee, for surely the name suggests the bee, though in fact she does not work upon it; but what shall we say of the Kansas poet, who, in his published volume, claims both the yew and the nightingale for his native state? Or of a Massachusetts poet, who finds the snow-drop and the early primrose blooming along his native streams, with the orchis and the yellow violet, and makes the blackbird conspicuous among New England songsters? Our ordinary yew is not a tree at all, but a low spreading evergreen shrub that one may step over, and as for the nightingale, if they have the mocking-bird in Kansas, they can very well do without

him. We have several varieties of blackbirds, it is true; but when an American poet speaks in a general way of the blackbird piping or singing in a tree, as he would speak of a robin or a sparrow, the suggestion or reminiscence awakened is always that of the blackbird of English poetry.

"In days when daisies deck the ground,
And blackbirds whistle clear,
With honest joy our hearts will bound
To see the coming year"—

Sings Burns. I suspect that the English reader of even some of Whittier's and Emerson's poems would infer that our blackbird was identical with the British species. I refer to these lines of Whittier:

"I hear the blackbird in the corn;
The locust in the haying"—

and to these of Emerson:

"Where arches green the livelong day
Echo the blackbirds' roundelay."

The blackbird of the English poets is like our robin in everything except color. He is familiar, hardy, abundant, thievish, and his habits, manners and song recall our bird to the life. Our own native blackbirds, the crow blackbird, the rusty grackle, the cow-bird and the red-shouldered starling, are not songsters, even in the latitude allowable to poets. The two first named have a sort of musical cackle and gurgle in spring (as at times both our crow and jay have), which is very pleasing, and to which Emerson aptly refers in these lines from "May-Day":

"The blackbirds make the maples ring
With social cheer and jubilee"—

but it is not a song. The note of the starling in the trees and alders along the creeks and marshes is better calculated to arrest the attention of the casual observer; but it is far from being a song like that of the European blackbird, or our robin. Its most familiar call is like the word "*bazique*," "*bazique*," but it has a wild musical note which Emerson has embalmed in this line:

"The red-wing flutes his *o-ka-lee*."

Here Emerson discriminates; there is no mistaking his blackbird this time for the European species, though it is true there is nothing fluty or flute-like in the red-wing's voice. The flute is mellow, while the "*o-ka-lee*" of the starling is strong and sharply accented. The voice of the thrushes (and our robin and the European black-

bird are thrushes) is flute-like. Hence the aptness of this line of Tennyson:

"The mellow ouzel fluted in the elm"—

the blackbird being the ouzel, or ouzel-cock, as Shakspeare calls him.

In the line which precedes this, Tennyson has stamped the cuckoo:

"To left and right,
The cuckoo told his name to all the hills."

The cuckoo is a bird that figures largely in English poetry, but he always has an equivocal look in American verse, unless sharply discriminated. We have a cuckoo, but he is a great recluse, and I am sure the poets do not know when he comes or goes, while to make him sing familiarly like the British species, as I have known at least one of our poets to do, is to come very wide of the mark. Our bird is as solitary and joyless as the most veritable anchorite. He contributes nothing to the melody or gayety of the season. He is indeed known in some sections as the "rain-crow"; but I presume that not one person in ten of those who spend their lives in the country has ever seen or heard him. He is like the *Orchis vera*, or the ladies'-slipper, or the shooting-star among plants,—a stranger to all but the few,—and when an American poet says cuckoo, he must say it with such specifications as to leave no doubt what cuckoo he means, as Lowell does, in his "Nightingale in the Study":

"And, hark, the cuckoo, weatherwise,
Still hiding, farther onward woos you."

In like manner the primrose is an exotic in American poetry, to say nothing of the snow-drop and the daisy. Its prominence in English poetry can be understood when we remember that the plant is so abundant in England as to be almost a weed, and that it comes early and is very pretty. Cowslip and oxlip are familiar names of varieties of the same plant, and they bear so close a resemblance that it is hard to tell them apart. Hence Tennyson, in "The Talking Oak":

"As cowslip unto oxlip is
So seems she to the boy."

Our familiar primrose is the evening primrose,—a rank, tall weed that blooms with the mullen in late summer. Its small, yellow, slightly fragrant blossoms open only at night, but remain open during the next

day. By cowslip, our poets and writers generally mean the yellow marsh marigold, which belongs to a different family of plants, but which, as a spring token and a pretty flower, is a very good substitute for the cowslip. Our real cowslip, the shooting-star (*Dodecatheon meadia*), is very rare, and is one of the most beautiful of native flowers. I believe it is not found north of Pennsylvania. I have found it in a single locality in the District of Columbia, and the day is memorable upon which I first saw its cluster of pink flowers, with their recurved petals cleaving the air. I do not know that it has ever been mentioned in poetry.

Another flower which I suspect our poets see largely through the medium of English literature and invest with borrowed charms, is the violet. The violet is a much more winsome and poetic flower in England than it is in this country, for the reason that it comes very early and is sweet-scented; our violet is not among the earliest flowers, and it is odorless. It affects sunny slopes, like the English flower; yet Shakspeare never could have made the allusion to it which he makes to his own species in these lines:

"That strain again! it had a dying fall;
Oh! it came o'er my ear like the sweet south,
That breathes upon a bank of violets
Stealing and giving odor,"

or lauded it as

"sweeter than the lids of Juno's eyes,
Or Cytherea's breath."

Our only sweet-scented violet is a small, white, lilac-veined species (not yellow, as Bryant has it in his poem) that is by no means common. I have found it a few times on the Potomac, but never upon the Hudson. It is obscure, and its perfume slight. Our common blue violet—the only species that is found abundantly everywhere in the North—blooms in May, and makes bright many a grassy meadow slope and sunny nook. Yet, for all that, it does not awaken the emotion in one that the earlier and more delicate spring flowers do; the hepatica, say, with its shy wood habits and pure, infantile expression; or the houstonia,—"innocence,"—flecking or streaking the cold spring earth with a milky way of minute stars; or the trailing arbutus, sweeter scented than the English violet, and outvying in tints Cytherea's or any other blooming goddess's cheek. Yet these flowers have no classical associations, and are, consequently, far less often upon the lips of our poets than the violet.

Bryant's poem on the yellow violet, above referred to, has all his accustomed simplicity and pensiveness; but the poet was certainly drawing largely upon his imagination for his facts. I have never been able to detect any perfume in the yellow species, and Gray, in his botany, ascribes no scent to it. Neither is it quite true that

"Of all her train, the hands of Spring
First plant thee in the watery mold;
And I have seen thee blossoming
Beside the snow-bank's edges cold."

It is not the first flower of spring, the hepatica is earlier; so is the houstonia.

Strict fidelity to nature, too, or to the largest fact of nature, would have prompted the poet in the first stanza to make his beechen woods musical with the robin's call or song, rather than with the "blue-bird's warble," as the blue-bird is so rarely seen in the woods, and the robin, at times in spring, makes such a jubilee there. The poet, of course, wanted the color, and had it at the expense of the larger fact.

To return to birds, another dangerous one for the American poet is the lark, and our singers generally are very shy of him. The term has been applied very loosely in this country to both the meadow-lark and the bobolink, yet it is pretty generally understood now that we have no genuine skylark east of the Mississippi. Hence I am curious to know what bird Bayard Taylor refers to, when he speaks in his "Spring Pastoral" of

"Larks responding aloft to the mellow flute of the
blue-bird."

Our so-called meadow-lark is no lark at all, but a starling, and the tit-lark and shore-lark breed and pass the summer far to the north, and are never heard in song in the United States.

The poets are entitled to a pretty long rope and a pretty free range, but they must be accurate when they particularize. They may, indeed must, see the fact through their imagination, but it must still remain a fact; the medium must not distort it into a lie. When they name a flower or a tree or a bird, whatever halo of the ideal they throw around it, it must not be made to belie the botany or the natural history. I doubt if you can catch Shakspeare transgressing the law in this respect, except where he followed the superstition, and the imperfect knowledge of his time, as in his treatment of the honey-bee. His allusions to nature

are always incidental to his main purpose, but they reveal a careful and loving observer. For instance, how are fact and poetry wedded in this passage, put into the mouth of Banquo!

"This guest of summer,
The temple-haunting martlet, does approve,
By his loved mansionry, that the heaven's breath
Smells woefully here; no jutting, frieze,
Buttress, nor coign of vantage, but this bird
Hath made his pendent bed and procreant cradle;
Where they most breed and haunt, I have observed,
The air is delicate."

Nature is of course universal, but in the same sense, is she local and particular—cuts every suit to fit the wearer, gives every land an earth and sky of its own, and a flora and fauna to match. The poets and their readers delight in local touches. We have both the hare and the rabbit in America, but this line from Thomson's description of a summer morning,—

"And from the bladed field the fearful hare limps
awkward,"—

or this from Beattie,—

"Through rustling corn the hare astonished
sprang,"—

would not apply with the same force here, because our hare is never found in the fields, but in dense, remote woods, and because both hares and rabbits abound in England to such an extent, that in places the fields and meadows swarm with them, and the ground is undermined by their burrows, till they become a serious pest to the farmer, and are trapped in vast numbers. The same is true of this from Tennyson:

"From the woods
Came voices of the well-contented doves."

Doves and wood-pigeons are almost as abundant in England as hares and rabbits, and are also a serious annoyance to the farmer, while in this country the dove and pigeon are much less marked and permanent features in our rural scenery,—less permanent, except in the case of the mourning-dove, which is found here and there the season through; and less marked, except when the hordes of the passenger-pigeon once in a decade or two invade the land, rarely tarrying longer than the bands of a foraging army. I hardly know what Trowbridge means by the "wood-pigeon" in his midsummer poem, for, strictly speaking, the wood-pigeon is a European bird, and a

very common one in England. But let me say here, however, that Trowbridge, as a rule, keeps very close to the natural history of his own country when he has occasion to draw material from this source, and to American nature generally. You will find in his poems the pewee, the blue-bird, the oriole, the robin, the grouse, the king-fisher, the chipmunk, the mink, the bobolink, the wood-thrush, etc., all in their proper places. There are few bird-poems that combine so much good poetry and good natural history as his "Pewee." Here we have a glimpse of the cat-bird:

"In the alders, dank with noon-day dews,
The restless cat-bird darts and mews;"

here, of the cliff-swallow:

"In the autumn, when the hollows
All are filled with flying leaves
And the colonies of swallows
Quit the quaintly stuccoed eaves."

Only the dates are not quite right. The swallows leave their nests in August, which is nearly two months before the leaves fall. The poet is also a little unfaithful to the lore of his boyhood when he says: "The partridge beats her throbbing drum" in midsummer. The partridge does not drum later than June, except fitfully during the Indian summer, while April and May are his favorite months. And let me say here for the benefit of the poets who do not go to the woods, that the partridge does not always drum upon a log; he frequently drums upon a rock or a stone wall, if a suitable log be not handy, and no ear can detect the difference. His drum is really his own proud breast and beneath his small hollow wings, gives forth the same low, mellow roll from a rock as from a log. Bryant has recognized this fact in one of his poems.

Our poets are quite apt to get ahead or behind the season with their flowers and birds. I have frequently seen the dandelion blooming in their pages with the clover, and the marsh marigold with the daisy. It is not often that we catch such a poet as Emerson napping. He knows nature, and he knows the New England fields and woods as few poets do. One may study our flora and fauna in his pages. He puts in the moose and the "surlly bear," and makes the latter rhyme with "wood-pecker":

"He saw beneath dim aisles, in odorous beds,
The slight Linnæa hang its twin-born heads.
* * * * *

"He heard, when in the grove, at intervals,
With sudden roar the aged pine-tree falls,—

One crash, the death-hymn of the perfect tree,
Declares the close of its green century."

"They led me through the thicket damp,
Through brake and fern, the beavers' camp."

"He saw the partridge drum in the woods;
He heard the woodcock's evening hymn;
He found the tawny thrush's broods;
And the shy hawk did wait for him."

His "Titmouse" is studied in our winter woods and his "Humble-Bee" in our summer fields. He has seen farther into the pine-tree than any other poet; his "May-Day" is full of our spring sounds and tokens; he knows the "punctual birds," and the "herbs and simples of the wood:"

"Rue, cinque-foil, gill, vervain, and agrimony,
Blue-vetch, and trillium, hawk-weed, sassafra,
Milk-weeds and murky brakes, quaint pipes and
sun-dew."

Here is a characteristic touch:

"A woodland walk,
A quest of river-grapes, a mocking thrush,
A wild rose, or rock-loving columbine,
Salve my worst wounds."

That "rock-loving columbine" is better than Bryant's "columbines, in purple dressed," as our flower is not purple, but deep orange. Yet Bryant set the example to the poets that have succeeded him of closely studying Nature as she appears under our own skies. He rarely makes a mistake, partly, perhaps, because he generally keeps on safe ground and seldom particularizes, but mainly, I think, because he was a real lover of Nature and observed her with affection. In "The Song of the Sower," he covers up part of the truth with the grain. The point and moral of the song he puts in the statement, that the wheat sown in the fall lies in the ground till spring before it germinates; when, in fact, it sprouts and grows and covers the ground with "emerald blades" in the fall:

"Fling wide the generous grain; we fling
O'er the dark mold the green of spring.
For thick the emerald blades shall grow,
When first the March winds melt the snow,
And to the sleeping flowers, below,
The early blue-birds sing.
* * *

"Brethren, the sower's task is done.
The seed is in its winter bed.
Now let the dark-brown mold be spread,
To hide it from the sun,
And leave it to the kindly care
Of the still earth and brooding air;
As when the mother, from her breast,
Lays the hushed babe apart to rest,
And shades its eyes and waits to see

How sweet its waking smile will be.
The tempest now may smite, the sleet
All night on the drowned furrow beat,
And winds that, from the cloudy hold
Of winter, breathe the bitter cold,
Stiffen to stone the mellow mold,
Yet safe shall lie the wheat;
Till, out of heaven's unmeasured blue,
Shall walk again the genial year,
To wake with warmth and nurse with dew
The germs we lay to slumber here."

Of course the poet was not writing an agricultural essay, yet one does not like to feel that he was obliged to ignore or sacrifice any part of the truth to build up his verse. One likes to see him keep within the fact without being conscious of it or hampered by it, as he does in "The Planting of the Apple-tree," or in the "Lines to a Water-fowl." Occasionally in other poems he seems to complete his picture without strict regard to the truth, as when he makes his "Summer Wind," which, from the "tall maize," must be a July wind, shake down showers of fragrant blossoms from the shrubs, whereas there are no shrubs or trees of any kind that I can recall that have fragrant blossoms so late in the season.

But there are glimpses of American scenery and climate in Bryant that are unmistakable, as in these lines from "Midsummer":

"Look forth upon the earth—her thousand plants
Are smitten; even the dark, sun-loving maize
Faints in the field beneath the torrid blaze;
The herd beside the shaded fountain pants;
For life is driven from all the landscape brown;
The bird has sought his tree, the snake his den,
The trout floats dead in the hot stream, and men
Drop by the sunstroke in the populous town."

Here is a touch of our "heated term" when the dog-star is abroad and the weather runs mad. I regret the 'trout floating dead in the hot stream,' because, if such a thing ever has occurred it is entirely exceptional. The trout in such weather seek the deep water and the spring holes, and hide beneath rocks and willow banks. The following lines would be impossible in an English poem:

"The snow-bird twittered on the beechen bough,
And 'neath the hemlock, whose thick branches
 bent
Beneath its bright, cold burden, and kept dry
A circle, on the earth, of withered leaves,
The partridge found a shelter."

Both Bryant and Longfellow put their spring blue-bird in the elm, which is a much better place for the oriole—the elm-loving oriole. The blue-bird prefers a humbler

perch. Lowell puts him upon a post in the fence, which is a characteristic attitude :

"The blue-bird, shifting his light load of song,
From post to post along the cheerless fence."

Emerson calls him "April's bird," and makes him "fly before from tree to tree," which is also good. But the blue-bird is not strictly a songster in the sense in which the sparrow or the indigo-bird, or the English robin-red-breast, is; nor do Bryant's lines hit the mark :

"The blue-bird chants, from the elm's long
branches,
A hymn to welcome the budding year."

Lowell again is nearer the truth when he speaks of his "whiff of song." All his notes are call-notes and are addressed directly to his mate. The song-birds take up a position and lift up their voices and sing. It is a deliberate musical performance, as much so that of Nilsson or Patti, but the blue-bird's only song is to call and warble the name of his mate in the most fond and endearing manner. He never strikes an attitude and sings for the mere song's sake. But the poets are perhaps to be allowed this latitude, only their pages lose rather than gain by it. Nothing is so welcome in this field as characteristic touches, a word or a phrase that fits this case and no other. If the blue-bird chants a hymn, what does the wood-thrush do? Yet the blue-bird's note is more pleasing than most bird-songs; if it could be reproduced in color, it would be the hue of the purest sky.

Longfellow makes the swallow sing :

"The darting swallows soar and sing"—

which would leave him no room to describe the lark, if the lark had been about. Bryant comes nearer the mark this time :

"There are notes of joy from the hang-bird and
wren,
And the gossip of swallows through all the sky;"

so does Tennyson when he makes his swallow

"Cheep and twitter twenty million loves;"

also Lowell again in this line :

"The thin-winged swallow skating on the air."

Longfellow is perhaps less close and exact in his dealings with nature than any of his compeers, although he has written some fine naturalistic poems, as his "Rain in Sum-

mer," and others. When his fancy is taken, he does not always stop to ask, Is this so? Is this true? as when he applies the Spanish proverb, "There are no birds in last year's nests," to the nests beneath the eaves; for these are just the last year's nests that do contain birds in May. The cliff-swallow and the barn-swallow always re-occupy their old nests, when they are found intact; so do some other birds. Again, bishop's-caps, the hawthorn or white-thorn, field-fares, belong to English poetry more than to American. The ash in autumn is not deep crimsoned, but a purplish brown. "The ash her purple drops forgivingly," says Lowell in his "Indian-Summer Reverie." Flax is not golden, lilacs are purple or white and not flame-colored, and it is against the law to go trouting in November. "Raghorn, the snow-white bull," had the poorest of pasture if it was made fragrant by "sweet pennyroyal," as this plant flourishes only in the most sterile land; and who does not know that grass thrives better in the North than in the South, notwithstanding that in "Evangeline" Basil, the old Acadian blacksmith, tells his guests that in Louisiana it grows more in a single night than in a whole Canadian summer; if for "grass" we read "corn," the statement comes nearer the truth. The woods flash in the sun after a sudden shower, but the "sheen of the dew" is never perceptible upon them. The pelican is not a wader any more than a goose or a duck is, and the golden robin or oriole is not a bird of autumn. This stanza from "The Skeleton in Armor" is a striking one :

"As with his wings aslant,
Sails the fierce cormorant,
Seeking some rocky haunt,
With his prey laden,
So toward the open main,
Beating to sea again,
Through the wild hurricane,
Bore I the maiden."

But unfortunately the cormorant never does anything of the kind; it is not a bird of prey: it is web-footed, a rapid swimmer and diver, and lives upon fish, which it usually swallows as it catches them. But cormorant here may stand for any of the large rapacious birds, as the eagle or the condor. True, and yet the picture is purely a fanciful one, as no bird of prey sails with his burden; on the contrary he flaps heavily and laboriously, because he is always obliged to mount. The stress of the rhyme and meter are of course in this case

very great, and it is they, doubtless, that drove the poet into this false picture of a bird of prey laden with his quarry. It is an ungracious task, however, to cross-question the gentle Muse of Longfellow in this manner. He is a true poet if there ever was one, and the slips I point out are only like an obscure feather or two in the dove carelessly preened. The burnished plumage and the bright hues hide them unless we look sharply.

Whittier gets closer to the bone of the New England nature. He comes from the farm, and his memory is stored with boyhood's wild and curious lore, with

"Knowledge never learned of schools,
Of the wild-bee's morning chase,
Of the wild flower's time and place,
Flight of fowl and habitude
Of the tenants of the wood;
How the tortoise bears his shell,
How the woodchuck digs his cell
And the ground-mole sinks his cell;
How the robin feeds her young;
How the oriole's nest is hung;
Where the whitest lilies blow,
Where the freshest berries grow,
Where the ground-nut trails its vine,
Where the wood-grape's clusters shine;
Of the black wasp's cunning way,
Mason of his walls of clay,
And the architectural plans
Of gray hornet artisans!"

"Brown wasp" and "black hornet" would be better, as we have no "gray hornet." The poet is not as exact as usual when he applies the epithet "painted" to the autumn beeches, as the foliage of the beech is the least painty of all our trees; nor when he speaks of—

"wind flower and violet, amber and white,"

as neither of the flowers named is amber colored. From "A Dream of Summer," the reader might infer that the fox shut up house in the winter like the musk-rat:

"The fox his hill-side cell forsakes,
The musk-rat leaves his nook,
The blue-bird in the meadow brakes
Is singing with the brook."

The only one of these incidents that is characteristic of a January thaw in the latitude of New England, is the appearance of the musk-rat. The fox is never in his cell in winter, except he is driven there by the hound, or by soft or wet weather, and the blue-bird does not sing in the brakes at any time of year. A severe stress of weather will drive the foxes off the mountains into the low, sheltered woods and fields, and a thaw will send them back again. In the

winter, the fox sleeps during the day upon a rock or stone wall or upon a snow bank, where he can command all the approaches, or else prowls stealthily through the woods.

But there is seldom a false note in any of Whittier's descriptions of rural sights and sounds. What a characteristic touch is that in one of his "Mountain Pictures":

"The pasture-bars that clattered as they fell."

It is the only strictly native, original and typical sound he reports on that occasion. The bleating of sheep, the barking of dogs, the lowing of cattle, the splash of the bucket in the well, "the pastoral curfew of the cow-bell," etc., are sounds we have heard before in poetry, but that clatter of the pasture-bars is American; one can almost see the waiting, ruminating cows slowly stir at the signal, and start for home in anticipation of the summons. Every summer day, as the sun is shading the hills, the clatter of those pasture-bars is heard throughout the length and breadth of the land.

"Snow-Bound" is the most faithful picture of our Northern winter that has yet been put into poetry. What an exact description is this of the morning after the storm:

"We looked upon a world unknown,
On nothing we could call our own.
Around the glistening wonder bent
The blue walls of the firmament,
No cloud above, no earth below,—
A universe of sky and snow."

The moonlight picture of the same scene has been much admired:

"The moon above the eastern wood
Shone at its full; the hill range stood
Transfigured in the silver flood,
Its blown snows flashing cold and keen,
Dead white, save where some sharp ravine
Took shadow," etc.;

but there is a false note here; it is in the word "flashing"; the snow-covered fields and hills do not flash under the full moon, they glow. When there is a crust or icing upon the snow, as after a rain, the hills and slopes gleam or shine, but they never flash. Nature's strong and striking effects are best rendered by closest fidelity to her. Listen and look intently, and catch the exact effect as nearly as you can.

It seems as if Lowell had done this more than most of his brother poets. In reading his poems, one wishes for a more plentiful supply of certain valuable, almost indispensable, qualities (I refer, of course, to his serious poems; his humorous ones are just

what they should be),—such as spontaneity, interior harmony and rhythm, etc.; yet the student of nature will find many close-fitting phrases and keen observations in his pages and lines that are exactly, and at the same time poetically, descriptive. He is the only writer I know of who has noticed the fact that the roots of trees do not look supple and muscular like their boughs, but have a stiffened, congealed look, as of a liquid hardened.

“Their roots, like molten-metal cooled in flowing,
Stiffened in coils and runnels down the bank.”

This is exactly the appearance the roots of most trees, when uncovered, present; they flow out from the trunk like diminishing streams of liquid metal, taking the form of whatever they come in contact with, parting around a stone and uniting again beyond it, and pushing their way along with many a pause and devious turn. One principal office of the roots of a tree is to gripe, to hold fast the earth; hence they feel for and lay hold of every inequality of surface; they will fit themselves to the top of a comparatively smooth rock, so as to adhere amazingly, and flow into the seams and crevices like metal into a mold.

Lowell is singularly true to the natural history of his own country. In his “Indian-Summer Reverie” we catch a glimpse of the hen-hawk, silently sailing overhead

“With watchful, measuring eye,”

the robin feeding on cedar berries, and

“The squirrel, on the shingly shag-bark’s bough.”

I do not remember to have met the “shag-bark” in poetry before, or that gray lichen-covered stone wall, which occurs further along in the same poem, and which is so characteristic of the older farms of New York and New England. I hardly know what the poet means by

“The wide-ranked mowers wading to the knee,”

as the mowers do not wade in the grass they are cutting, though they might appear to do so when viewed athwart the standing grass; perhaps this is the explanation of the line.

But this is just what the bobolink does, when the care of his young begins to weigh upon him:

“Meanwhile that devil-may-care, the bobolink,
Remembering duty, in mid-quaver stops

Just ere he sweeps o’er rapture’s tremulous brink,
And ’twixt the windrows most demurely drops.”

I do not vouch for that dropping between the windrows, as in my part of the country the bobolinks flee before the hay-makers, but that sudden stopping on the brink of rapture, as if thoughts of his helpless young had extinguished his joy, is characteristic.

Another carefully studied description of Lowell’s is this:

“The robin sings, as of old from the limb!
The cat-bird croons in the lilac-bush!
Through the dim arbor, himself more dim,
Silently hops the hermit thrush.”

This is so correct, indeed, that one is surprised to find in his poems the conventional blackbird whistling the old whistle of English poetry, as in “Rosaline,”

“A blackbird whistling overhead
Thrilled through my brain;”

and again in “The Fountain of Youth,”

“’Tis a woodland enchanted!
By no sadder spirit
Than blackbirds and thrushes,
That whistle to cheer it
All day in the bushes,” etc.

Our blackbirds—the grackles and the cow-bird—are even poorer whistlers than they are songsters. The former have a wheezy, catarrhal cackle and chatter, as I have before stated, that is not in the least like a whistle, and the latter a liquid gurgling note or two. The thrushes may be said to whistle at times, but our most marked whistler is the Virginia red-bird, or cardinal grosbeak. Its instrument, I imagine, is much like that of the European bulfinch.

Among trees Lowell has celebrated the oak, the pine, the birch; and among flowers, the violet and the dandelion. The last, I think, is the most pleasing of these poems:

“Dear common flower, that grow’st beside the
way,
Fringing the dusty road with harmless gold,
First pledge of blithesome May.”

The dandelion is, indeed, in our latitude, the pledge of May. It comes when the grass is short, and the fresh turf sets off its “ring of gold” with admirable effect; hence we know the poet is a month or more out of the season when, in “Al Fresco,” he makes it bloom with the buttercup and the clover:

“The dandelions and buttercups
Gild all the lawn; the drowsy bee
Stumbles among the clover-tops,
And summer sweetens all but me.”

The buttercup and the clover bloom in June, and are contemporaries of the daisy. Our poet would bankrupt Nature by the lavish use of her gold. He is also at fault when in his "Fable for Critics" he makes the bees throng round a rose, for the bee does not work upon this flower.

I smile as I note that the woodpecker proves a refractory bird to Lowell, as well as to Emerson :

Emerson rhymes it with bear,
Lowell rhymes it with hear,
One makes it woodpeckair,
The other, woodpeckear.

But its hammer is a musical one, and the poets do well to note it. An Illinois poet, I observe, ascribes the "rat-tat-tat" of the downy or hairy woodpecker, heard so often in early spring upon the resinous limbs, and again in the Indian summer, to the yellow-hammer, or high-hole. The high-hole is almost entirely a ground pecker, and his beak is seldom heard upon limb or tree, except when he is excavating a nest. Our most musical drummer upon dry limbs among the woodpeckers is the yellow-bellied. His measured, deliberate tap, heard in the stillness of the primitive woods, has an effect that no bird-song possesses.

Tennyson is said to have very poor eyes, but there seems to be no defect in the vision with which he sees Nature, while he often hits the nail on the head in a way that would indicate the surest sight. True, he makes the swallow hunt the bee, which, for aught I know, the swallow may do in England. But what a clear-cut picture is that in the same poem ("The Poet's Song")!

"The wild hawk stood, with the down on his beak,
And stared, with his foot on the prey."

It takes a sure eye, too, to see

"The landscape winking thro' the heat"—

or to gather this image :

"He has a solid base of temperament;
But as the water-lily starts and slides
Upon the level in little puffs of wind,
Though anchor'd to the bottom, such is he;"

or this :

"—arms on which the standing muscle sloped,
As slopes a wild brook o'er a little stone,
Running too vehemently to break upon it,"

and many other gems that abound in his

poems. He does not cut and cover in a single line, so far as I have observed. Great caution and exact knowledge underlie his most rapid and daring flights. A lady told me that she was once walking with him in the fields when they came to a spring that bubbled up through shifting sands in a very pretty manner, and Tennyson, in order to see exactly how the spring behaved, got down on his hands and knees and peered a long time into the water. The incident is worth repeating as showing how intently a great poet studies nature.

Walt Whitman says he has been trying for years to find a word that would express or suggest that evening call of the robin. How absorbingly this poet must have studied the moonlight to hit upon this descriptive phrase :

"The vitreous pour of the full moon just tinged with blue"—

how long have looked upon the carpenter at his bench to have made this poem :

"The tongue of his fore-plane whistles its wild ascending lisp;"

or how lovingly listened to the nocturne of the mocking-bird to have turned it into words in "A Word out of the Sea." Indeed, no poet has studied American nature more closely than Whitman has—or is more cautious in his uses of it. How easy are his descriptions!

"Behold the day-break!
The little light fades the immense and diaphanous shadows!"

"The comet that came unannounced
Out of the north, flaring in heaven."

"The fan-shaped explosion."

"The slender and jagged threads of lightning, as sudden and fast amid the din they chased each other across the sky."

"Where the heifers browse—where geese nip their food with short jerks;
Where sundown shadows lengthen over the limitless and lonesome prairie;
Where herds of buffalo make a crawling spread of the square miles far and near;
Where the humming-bird shimmers—where the neck of the long-lived swan is curving and winding;
Where the laughing-gull scoots by the shore when she laughs her near human laugh;
Where band-neck'd partridges roost in a ring on the ground with their heads out."

Whitman is less local than the New England

poets and faces more to the West. But he makes himself at home everywhere, and puts in characteristic scenes and incidents, generally compressed into a single line, from all trades and doings and occupations, North, East, South, West, and identifies himself with man in all straits and conditions on the continent. Like the old poets, he does not dwell upon nature, except occasionally through the vistas opened up by the great sciences, as astronomy and geology, but upon life and movement and personality, and puts in a shred of natural history here and there, the "twittering red-start," the spotted-hawk swooping by, the oscillating sea-gulls, the yellow crowned heron, the razor-billed auk, the lone wood-duck, the migrating geese, the sharp-hoofed moose, the mocking-bird, "the thrush, the hermit," etc., to help locate and define his position. Everywhere in nature, Whitman finds human relations, human responses. In entire consistence with botany, geology, science, or what not, he endues his very seas and woods with passion, more than the old hamadryads or tritons. His fields, his rocks, his trees, are not dead material, but living companions. This is doubtless one reason why Addington Symonds, the young Hellenic scholar of England, finds him more thoroughly Greek than any other man of modern times.

Our natural history, and indeed all phases of life in this country, are rich in materials for the poet that have yet hardly been touched. Many of our most familiar birds, which are inseparably associated with one's walks and recreations in the open air, and with the changes of the seasons, are yet awaiting their poet,—as the high-hole, with his golden-shafted quills and loud continued spring call; the meadow-lark, with her crescent-marked breast and long-drawn, piercing, yet tender April and May summons, forming, with that of the high-hole, one of the three or four most characteristic field sounds of our spring; the happy gold-finch, circling round and round in midsummer with that peculiar undulating flight and calling *per-chick'-o-pee, per-chick'-o-pee*, at each opening and shutting of the wings, or later leading her plaintive brood among the thistle-heads by the roadside; the little indigo bird, facing the torrid sun of August and singing through all the livelong summer day; the contented musical soliloquy of the vireo, like the whistle of a boy at his work, heard through all our woods from May to September:

Pretty green worm, where are you?
 Dusky-winged moth, how fare you,
 When wind and rain are in the tree?
 Cheeryo, cheerebly, chee,
 Shadow and sun one are to me.
 Mosquito and gnat, beware you,
 Saucy chipmunk, how dare you
 Climb to my nest in the maple-tree,
 And dig up the corn
 At noon and at morn?
 Cheeryo, cherreibly, chee;—

or the phœbe-bird, with her sweet April call and mossy nest under the bridge or woodshed, or under the shelving rocks; or the brown thrasher—mocking thrush—calling half furtively, half archly from the tree-top, back in the bushy pastures: "Croquet, croquet, hit it, hit it, come to me, come to me, tight it, tight it, you're out, you're out," with many musical interludes; or the cheewink, rustling the leaves and peering under the bushes at you; or the pretty little oven-bird, walking round and round you in the woods, or suddenly soaring above the tree-tops, and uttering its wild lyrical strain; or farther south, the whistling red-bird, with his crest and military bearing—these and many others should be full of suggestion and inspiration to our poets. It is only lately that the robin's song has been put into poetry. Nothing could be happier than this rendering of it by a nameless singer in "A Masque of Poets."

"When the willows gleam along the brooks,
 And the grass grows green in sunny nooks,
 In the sunshine and the rain
 I hear the robin in the lane
 Singing 'Cheerily
 Cheer up—cheer up;
 Cheerily, cheerily
 Cheer up.'

'But the snow is still
 Along the walls and on the hill.
 The days are cold, the nights forlorn,
 For one is here and one is gone.
 'Tut, tut. Cheerily,
 Cheer up, cheer up;
 Cheerily, cheerily
 Cheer up.'

"When spring hopes seem to wane,
 I hear the joyful strain—
 A song at night, a song at morn,
 A lesson deep to me is borne,
 Hearing, 'Cheerily,
 Cheer up, cheer up;
 Cheerily, cheerily,
 Cheer up.'"

The poetic interpretation of nature, which has come to be a convenient phrase, and about which the Oxford professor of poetry has written a book, is, of course, a myth, or is to be read the other way. It is the soul

the poet interprets, not nature. There is nothing in nature but what the beholder supplies. Does the sculptor interpret the marble or his own ideal? Is the music in the instrument, or in the soul of the performer? Nature is a dead clod until you have breathed upon it with your genius. You commune with your own soul, not with woods or waters; they furnish the conditions, and are what you make them. Did Shelley interpret the song of the sky-lark, or Keats that of the nightingale? They interpreted their own wild, yearning hearts. The trick of the poet is always to idealize nature—to see it subjectively. You cannot find what the poets find in the woods until you take the poet's heart to the woods. He sees Nature through a colored glass, sees it truthfully, but with an indescribable charm added, the aureole of the spirit. A tree, a cloud, a bird, a sunset, have no hidden meaning that the art of the poet is to unlock for us. Every poet shall interpret them differently, and interpret them rightly, because the soul is infinite. Milton's nightingale is not Coleridge's; Burns's daisy is not Wordsworth's; Emerson's humble-bee is not another's; nor does Turner see in nature what Tintoretto does, nor Veronese what Correggio does. Nature is all things to all men. "We carry within us," says Sir Thomas Browne, "the wonders we find without." The same idea is daintily expressed in these tripping verses of Bryant's:

"Yet these sweet sounds of the early season
And these fair sights of its early days,
Are only sweet when we fondly listen,
And only fair when we fondly gaze.

"There is no glory in star or blossom,
Till looked upon by a loving eye;
There is no fragrance in April breezes,
Till breathed with joy as they wander by;" —

and in these lines of Lowell:

"What we call Nature, all outside ourselves,
Is but our own conceit of what we see,
Our own reaction upon what we feel" —

"I find my own complexion everywhere."

Before either, Coleridge had said:

"We receive but what we give,
And in our life alone doth Nature live;
Ours is the wedding-garment, ours the shroud" —

and Wordsworth had spoken of

"The light that never was on sea or land,
The consecration and the poet's dream."

That light that never was on sea or land is what the poet gives us, and is what we mean by the poetic interpretation of nature. The Oxford professor struggles against this view. "It is not true," he says, "that nature is a blank, or an unintelligible scroll with no meaning of its own but that which we put into it from the light of our own transient feelings." Not a blank, certainly, to the scientist, but full of definite meanings and laws, and a store-house of powers and economies; but to the poet the meaning is what he pleases to make it, what it provokes in his own soul. To the man of science it is thus and so, and not otherwise; but the poet touches and goes, and uses nature as a garment which he puts off and on. Hence the scientific reading or interpretation of nature is the only real one. "A little have I read," says the old herb doctor in Shakspeare—

"A little have I read in Nature's infinite book
of secresy."

This is science bowed and reverent, and speaking through a great poet. The poet himself does not so much read in Nature's book—though he does this, too—as write his own thoughts there; Nature reads him, she is the page and he the type, and she takes the impression he gives. Of course the poet uses the truths of nature also, and he establishes his right to them by bringing them home to us with a new and peculiar force—a quickening or kindling force. What science gives is melted in the fervent heat of the poet's passion, and comes back to us supplemented by his quality and genius. He gives more than he takes, always.

ODDITIES OF PARIS.

THERE are two classes of tradesmen in Paris that never come to grief: dealers in eggs and butter, and buyers and sellers of philosophers. Mr. Emerson once said, pointing to the pride of his orchard: "That apple-tree is worth more than my head to me. My income from the former is greater than the revenue from all my books." But then Emerson has only sold *philosophy*—had he bought and sold *philosophers*, he would now be master of lands, tenements and hereditaments, valuable enough to win him the respect of all State street.

I was sitting some time since in a notary's office, when a man of most sordid appearance entered. He surprised me very much, for it is rare to see a tatterdemalion in Paris. Polonius knew the city thoroughly when he cautioned Laertes: "Costly thy habit as thy purse can buy." Here everybody puts his best foot foremost. The new-comer, however, was in rags, and his matted hair and unshaven face added to his repulsive appearance. I was still more surprised by the deference paid him. (Magic power of gold which gives even beauty to the beast!) He drew from the recesses of his rags, rather from wells than pockets, so deep and capacious were they, so many packets of bank-notes, and so many rolls of gold coin, that my surprise grew greater and greater. I began to think of Signor Blitz, the Fakir of Ava, the Wizard of the North. I rubbed my eyes and was all attention, that I might lose no particular of the transformation scene, which I was sure was at hand. But I was disappointed.

"I have always made it a rule," he snorted, "to have a fifty-thousand-dollar house for myself, and to give as good a house to my children on their majority. My eldest son and my only daughter have each a house. The house I am now buying is for my youngest son, who will be one-and-twenty the first of next month." As he spoke he marshaled coin and bank-notes for ready counting on the table, and growled as he laid them down: "See if there are not fifty thousand dollars here!" The deed of sale needed only signature. This formality ended, he withdrew, accompanied to the office door by the notary. On his return the latter asked:

"Can you divine that man's occupation?"

"An usurer?"

"No. He buys and sells philosophers. But may be you don't know what a 'philosopher' is?"

"An inquirer into the nature of the under"——

"No, no, no! I need not tell you there is no end to the avatars of every object in Paris. Here water becomes wine and wine is turned into water. The bread left on café and restaurant tables becomes toast for soup. Clothes go from the rich fine gentleman's back to the poor fine gentleman's back, thence to lower and still lower poverty, till they reach the shoddy mill, which transforms them into wool again. Shoes do not escape the common fate. They fall from rich to poor, then to poorer and to poorer still, until at last the soles are completely worn out and nothing but the uppers remain, battered, and worse for wear, but still no myth, as soles have long since become. These are 'philosophers.' They are used—the best of them—to make shoes, sold for new by shop-keepers whose consciences were left behind in their native villages; the others, to make the 'new shoes' you see in cobblers' stalls. The former—the 'Platos'—sell for six or eight cents a pair. The latter—the 'Schopenhauers'—never bring more than four cents. The man who has just left us is the largest dealer in these articles in Paris. I am afraid to repeat the figures he gave me as the annual total amount of money he turns over in the way of trade. You would not credit it. I will, however, tell you that he is worth at least \$600,000—perhaps \$800,000. Of course all this money was not made by buying and selling 'philosophers,' no more than Rothschild has made all his money by banking. Nobody makes money in this world; wealth is money saved. As money flowed in (and it came in torrents), he spent as little and invested as much of it as he could. He had a keen eye for investments; he made money out of the Mexican loan, and a fortune in the Turkish funds; he has even had the art to squeeze money out of Spanish railway shares. When he dies he will be worth two millions of dollars!"

How badly distanced is Emerson's apple-tree!

Do you see that somber, uninviting-look-

ing shop with the door always closed, with the windows curtained, not by muslin or dimity, but by silk dresses, rich cashmere shawls, yards of velvet, embroidered petticoats, with fur muffs, bracelets, watches and chains on the sill, with pawnbrokers' tickets here and there among them; nothing arranged for effect, as in the show-windows of other trades? It is the shop of a "toilette dealer." If you would know the lowest depth of the mysteries of Paris, be her—no, I wont say friend, for her friendship is dangerous, because the law calls her friends accomplices, and frequently pillories the "toilette dealer" and her accomplices in the dock of the Assizes Court and in the new-fashioned stocks which have abolished those of Tyburn Hill—the press—which is ten times severer punishment, since in the stocks the criminal was anonymous, while in the press his name is published, though his face be hid. The "toilette dealers" are not always old, scrawny, wrinkled and long-fingered. Some of them are young and pretty—pretty as tiger's dappled skin or serpent's gaudy twine and far more dangerous than either, for their fangs poison not only body but soul, not only one's credit, but one's name, not only one's estate, but one's honor. Their business is—what is it not beyond the precincts of honesty? They carry letters of marque and reprisal, and become pirates when the horizon is unwhitened by a third sail. They will do anything for money—any of the crimes of civilization, be it understood, which escape the law, and the law hath a coarse hand which cannot pick up delicate offenses. They will not knock a man in the head; they will not brew a deadly cup; but they know everybody of both sexes who wants money and who values money above everything else in the world. They keep up correspondence with all of the ten tribes, and are on intimate terms with all the "little Moseses" of the Ghetto of Paris. They know everybody and everything in Paris. Does a splendid dress in some shop window of Boulevard des Capucines strike your eye? The toilette dealer will buy it for you. Have you an irresistible longing for a lace and cashmere shawl seen in the Rue Richelieu? She will gratify your longing. Would you like to hire a suit of fine clothes, diamonds, watches, bank-notes for a ball, or a wedding, or a funeral, or for the season? She will supply you. She is an usurer, too, and a pawnbroker,—both pursuits forbidden by law,—her "best conscience is, not to leave

undone, but to keep unknown." She is youth's banker, youth's providence. She cashes all drafts which Beauty draws on Hope. I do not say her terms will be easy as those of Messrs. Cheeryble Brothers. You must remember she ministers, not to your necessities, but to your craving for life's superfluities, and superfluities are always costly. Superfluities, especially when they are flavored with vice, the costliest spice on earth, are as expensive as strawberries in December.

How is it that old clo' dealers always have so many French horns, those great coiled yellow serpents we see in every brass band? They are favorite instruments in Paris, for all Frenchmen think the essence of amusement is noise. I once lived opposite a family who spent Sunday in screeching songs, accompanied not only by the piano, but also by tumblers and saucepans beaten with forks; the louder the noise the greater the ecstasy of their delight. There is not a forest near Paris whose silence is not broken by the French horn. Altogether, the insensibility of the French to noise is amazing. If you live near a private mansion, you hear the bell going from morning to night, as incessantly as drum and trumpet in a French barracks, and the bell used would hardly be considered by us too small for a North River steamboat. When it is rung for breakfast or dinner, the peal is always preceded by three taps. They are probably meant to invoke the Trinity, like the three strokes that precede morning, noon and evening Angelus ("In the name of the Father and of the Son and of the Holy Ghost"), as is done by the three signs of the Cross when holy water is taken, or when a funeral is met in the street. These three taps are never given when the bell rings for servants' meals.

The oil-men's shops offer one of the few examples of bad taste to be found in Paris. They are streaked with every color, and these the crudest tones to be had. The walls where bills are posted are always odd—nearly as variegated as the front of an oil-man's shop, though the tones are softer. The government reserves white paper for its own proclamations: latest constitutions, announcements of new presidents and capitals, etc. Each theater also has its own colored paper. A political party would scorn to print its announcements on paper which was not in its livery. All cards of furnished lodgings

to be let are on yellow paper; all furniture vans for moving and their offices are painted yellow. Formerly, all lamps at the doors of government offices—such as firemen's barracks, police stations, offices of the police commissioners, tobacconists (the tobacco trade is a government monopoly), and water-bailiffs' offices—were red. Military patrols carry a red lantern,—imagine a red lantern with a tallow candle in a street illuminated with the electric light; routine only can be responsible for such an absurdity. Latterly, post and telegraph offices have adopted blue lamps. Each line of omnibuses has lamps of its own color, and the lamps of each cab of the great Cab Company are the color of its stable—a convenient regulation for the belated wayfarer who would be driven home by a willing Jehu, for he has but to choose a cab whose stable is near his destination. The effect of so many different colored lamps is most picturesque when seen in a long vista like the Boulevards or the far-famed Avenue de l'Opéra and rues du 4 Septembre and de la Paix, or the Avenue des Champs Élysées, or (where it is still more striking) in the Place de la Concorde.

A crowd is always to be seen around the bird-fanciers' shops, which are most numerous on Quais de l'École and de la Mégisserie, looking at countless varieties of the feathered tribe, from Cochon China cocks to microscopic canaries. The French have a passion for society, especially noisy society, and there is always an active trade in birds. One often witnesses touching scenes in front of these shops. To give a single instance, I remember once seeing a poor white-haired rag-picker, bent double with age, cares, and basket, totter to a shop-door and ask: "Could a cent buy any sort of a bird?" In what an insolent tone the snub was given: "No—not even a dead bird!" She made no answer, but turned most sorrowfully away. She wanted something to love, and to be loved by something. It is amusing to see Frenchmen listening to the birds—ears, eyes and mouth wide-stretched, that not a bit of the racket shall escape the channels to the brain. After listening rapt in admiration, they suddenly exclaim: "Good Heavens, don't they make a noise!" in the tone you would use were you to say: "How delightfully Gerster sings!"

There is nothing stranger in Paris than marriage. French courtship would suit a bashful fellow (there is none but imported bashfulness in France). The fathers

do all the wooing. They are even the ones who fall in love. Last week I saw two fathers courting, and, as is often the case, 'twas the girl's father who fell in love and popped the question to the boy's. The former lives in a village in Touraine and manufactures hose. The latter sells hose wholesale and retail in Paris. The first said:

"I have a marriageable daughter; I have a son—these are all my children. I shall give each of them \$20,000 the day they are married. I am now worth \$100,000. If I live twenty years more I shall be worth \$300,000. When I am dead this will go to my children, share and share alike. I should at once make my son-in-law my Paris agent. This would throw a good income annually into his hands. Do these terms suit you? Will you meet me half-way?"

Claude Melnotte makes love more poetically; but when courting is carried on in this way with addition, multiplication, division, and subtraction for crutches, the pot is sure to boil. Still, I prefer Claude Melnotte's method. The Parisian replied:

"My son is young yet. I have never thought of his marriage." He said to me afterward: "I never buy a pig in a poke. I must see the girl before I give an answer. If she suits, I shall strike hands. If she doesn't—your servant, sir!" Some weeks afterward, he found a pretext in the way of business to visit the father. He told me, on his return: "I have seen the girl. She is not strong enough." So Cupid carried his bow, arrow, and quiver to another house, where girl and purse were stouter. A great many persons in the higher classes, especially in the old Legitimist noble families, who are great sticklers for old usages, never see the person they are to marry until the groom calls at the convent to take his bride to the church.

The place given to money in Parisian marriages tells heavily upon the poor, especially upon those who are obliged to wear the livery of respectability. The cost of service in the churches seems skillfully planned in the manner best suited to goad to expense not only vanity, but self-respect also. Custom, too, makes burdensome levies on the purse. There must be carriages to the Mayor's office and to church; the bride must have her outfit, and there must be an entertainment. I remember the marriage of the daughter of an officer in the French army. He was poor as a church mouse,

and never was quite sure that his wife would succeed in making his pay last the month. A little hunchback met the daughter at a ball and fell in love with her. He was worth \$8,000 a year. She saw his spine in his land (where it was as straight as an arrow) and let him know at once that his suit would be successful. By dint of borrowing \$25 here, \$30 there, \$50 in another place, and other dribbles right and left, and by getting a "toilette dealer" to make all the purchases for the outfit, upon promise the husband should pay before the honeymoon changed, they managed to get through the ceremony without confessing their poverty. The day after the wedding the mother said to me: "You cannot imagine the embarrassment into which we were thrown by Louise's marriage; for, poor as we are, we could not send her stark naked into her new family. My husband had his uniform, and that, of course, passes muster anywhere; but I did not know what to do for a dress. I bought a shawl trimmed with lace for the marriage. I took the lace from the shawl and put it on my new silk dress for the ball. This morning I removed it from the dress and put it back on the shawl in time to pay visits." Running the gauntlet would be a pleasant promenade, compared to the anxiety and embarrassment of this family during the six weeks before, and the three weeks after, their daughter's marriage. The wedding over, it remained painfully uncertain what reception the husband would give his betrothed's bills. They were many, and some of them were heavy. The sum total was very large, but he paid them without wincing.

It is odd that masters and mistresses should always require servants to address them in the third person. A French servant, in a house where there is any etiquette, would never dream of saying: "Shall I light the lamp, sir?" He would inquire: "Does Mister wish the lamp lighted?" Not, "Do you wish tea or coffee, Ma'am?" but, "Does Ma'am wish tea or coffee?" It is very amusing to see a servant from the country, who never heard of the third person, learning this etiquette.

In Paris, all trades and callings have their Rialto, where employers know they can find the unemployed. It is curious, and in inclement weather painful, to see laundresses of all ages standing in Rue Mauconseil, wool-carders standing in Rue du Caire, stone-masons standing in the Place de l'Hôtel de Ville, and men who

turn wheels in workshops waiting to be employed (for in many factories in Paris neither gas nor steam has yet been introduced).

All Parisian colleges require that each boarder shall have a surety in town who is not only responsible for bills, but who undertakes to receive the boy on holy days, and if he is expelled. These "correspondents" (as they are called) must return the boarder, in person or by proxy, to the college authorities, when the holy day is ended. As it would be inconvenient for most correspondents to go for and to return their clients, around every college door proxies offer themselves for hire. The charge is invariably the same, twenty-five cents for conveying the boy each way. It is one of the oddest things in Paris to see the number of proxies that can always be hired. At each ward office there are men who live, and who make excellent incomes, by hiring themselves as witnesses to bills, marriages, deaths, and legal instruments. The French law allows no woman to witness a legal paper, and requires seven witnesses to some documents. I have seen some laughable incidents where the witnesses were incompetent, the legal instrument was important, and the officer was irritated by the farce in which he was obliged to play a part.

There is not a Paris vintner with a spark of self-respect under his waistcoat who has not at least one "guardian angel" in his employment. The "guardian angel" is a cherub of placid temper, in smock shirt, ears insensible to vituperation, arms strong enough to parry and support, honesty that can see gold, silver, and copper, without remembering hocus-pocus. When, by oft wetting his throat, a customer grows limp and so imaginative as to see streets, houses, and lamp-posts dancing a *grand galop infernal* expressly to prevent him from walking home, the guardian angel then makes his appearance, rifles his wet countryman's pockets, draws the weak arm in his, walks the brainless fellow home, gives his wife all the contents of the pockets, and carries away her blessing.

There is nothing odder in Paris than the private collections, especially the cabinets of pictures. Had Raphael lived a thousand years, and painted day and night, he could not have covered the canvas shown in Paris as his works. Some of these collections contain the clothes of eminent people; others have buttons; others still have shoes; here are snuff-boxes; there are wigs; yon-

der are fire-irons. All sorts of trash have their idolaters, as I discover, when I visit these queer nooks. I come away convinced there is nothing lost in this world. The earnest look, the important air, and the pride these people take in showing their collection, though it be only chessmen, is amusing.

How strange, too, are the girls who go every Sunday to the Hotel des Invalides to cheer the lagging spirits of the old war-beaten men, who deprive themselves of wine or tobacco during the week to give four cents to the child that prattles of hope and the future with the airy confidence childhood alone possesses, and recalls to the half-closed eyes and half-insensible ears of the veterans a time when they, too, hoped, when they, too, mirrored themselves in bright eyes, and by flattering speeches made them sparkle. There, also, are women who take the old soldiers to dry nurse, who feed them and treat them and give them company—a kind word here, a gentle smile there, an exhibition of interest in the continued conjunction of soul and body on which the old soldier's pension hangs.

Unless it be the bread six feet long which stands in bakers' shops like grenadiers at a review, nothing strikes a stranger more forcibly than the numbers of idle people of the lower classes seen lolling on the benches of all the public squares. How do they get the bread of idleness? I was some time since in Place de l'Observatoire, which was unusually thronged. I met a policeman of my acquaintance and asked him: "Who are all these people?" He answered: "Professional thieves." When I recently visited the cellars of the great markets, the officer who went with me became very angry with the people in the cellars, who were noisy. He said to me: "Every one of these people is a thief, liberated this morning." All of the people seen sleeping on benches are vagabonds. Were they found asleep in the streets at night they would be arrested, so they walk all night. Many of them are inmates of some of the asylums where decayed servants and the like are harbored during their last years; but it is astonishing how many able-bodied people are to be found among these saunterers. The ambition of Frenchmen of all classes is to lead an idle life; and to enjoy this idleness they gladly deny themselves what we consider the prime necessities of life. If a Frenchman have bread and wine he is never hungry, and never grows lean.

Nor does he care for fire in winter. I have often been surprised to find the dining-rooms, even of wealthy people, unwarmed, and to hear them say: "We never have a fire in the dining-room, for we find the meal warms us very comfortably." Being so easily satisfied, many of them cease to work as soon as they have acquired a revenue of \$200 a year.

In the public squares there is a never-failing round of amusements, which may be enjoyed without charge. Here is a noisy dealer in puns, which he rattles off as fast as he can make his tongue go, and which he sells for one cent the printed sheet. His wit by infusion is always in demand. Hard by is a still more noisy dealer in songs. He grinds the accompaniment out of a hand-organ, bawls song after song, and when he stops to catch breath, appeals to a discriminating public to buy the words whose tune he has taught them. Fortune-tellers, somnambulists, rope-dancers, masters of white mice, venders of magical waters which dye hair any color, or cure all diseases, or make brass shine like gold, all with a hand-organ for an ally, give great animation to the public squares. Besides these, there are orange-sellers, who yell the merits of their "Valencia oranges"; sugar-waffle makers, who shrilly cry: "Here are sugar-waffles, ladies—here are sugar-waffles—regale yourselves; flower-venders, whose scream is: "Flower yourselves, ladies, flower yourselves!" Add the cabstand and omnibus office in nearly every square, with vehicles incessantly going and coming, and you may conceive the animation of the scene, and understand what makes it so attractive to French eyes and to French ears.

I often pause and listen to street brawls, which are frequently mere wordy combats, and amuse myself by discovering traces of this nation's history and character in the opprobrious epithets the disputants hurl at one another. The word oftenest heard is *ostrogot!* (I give it as pronounced), which evidently is *ostrogoth*. I have often heard *sarrasin!* "*Cossack!*" is still very common. *Guillou?* ("will you?") is the only trace of English invasion I have discovered. Since the German war *Prussien!* and *Canaille de Bismarck!* and *Va donc, Bismarck!* are often used. No epithets sting deeper than these.

The first Revolution passed over Paris as the deluge over the earth, sparing nothing. Don't ask in France for tombs of ante-revolutionary heroes. Nobody can direct you

to La Bruyère's, nor to Montesquieu's, nor to Racine's, nor to Pascal's. Molière's jawbone is in the Hotel de Cluny; half of Cardinal de Richelieu's head had been in market for seventy-five years when the government bought it and restored it to the vault where his whole body was laid in almost royal state. Cardinal de Mazarin's tomb is tenantless, and the fragments of his monument are to be seen in one of the museums of the Louvre. Scarron's skull, polished by oft handling to ivory smoothness, is shown for a fee in St. Gervais church; and in another church, silver will give you sight of the skull of St. Vincent de Paul.

Place Royale was once the fashionable public resort. Then fine folks showed themselves nowhere so brilliantly as on Pont Neuf; presently it was the Palais Royal's day; now the Boulevard des Italiens is waning that the Boulevard des Capucines may be brilliant. In Louis XIV.'s days, the bankers swarmed in Rue Neuve St. Merri, now mantled with such sanguinary associations, where pale, wan working-people toil for bread under ceilings which once covered millionaires. Those wainscots, which once saw all the luxuries of the world, now do not see regular meals. Bankers in another generation moved from Rue Neuve St. Merri to Rue Quincampoix, where to be a hunchback was to have a fortune, writing-desks were so scarce when John Law lorded it over France; but here, too, the wan artisan has inherited the bankers' mansions. 'Twas down this street which once led from the Palais de Justice and Louvre to St. Denis that live kings went to Rheims to be crowned, and made triumphal entrance on their return. Even Charles X. made his entrance into his capital through this street. Dead kings were borne down it to St. Denis to be buried. Now its glory has departed.

There is no end to the odd names on street signs. Balzac, Scribe and Victor Hugo explored them to find names for their characters. Poet and novelist may strain their invention to the utmost, all the rest of mankind have more imagination than the whole legion of authors. In these signs puns abound. They are rarely translatable; but this one may be mentioned, for it is found in almost every street in Paris. Quince is *coing*; street corner is *coin*; both of these words are pronounced alike. There is scarcely a vintner's shop at a street corner which has not for sign a large gilt quince. It is sometimes accompanied by this legend: "At the good *coing*." A favorite sign of

the vintner's shops, near the wall, where the fortifications separate Paris from the country, is a rabbit standing on his hind legs, his head turned bewitchingly toward the public and one fore paw pointed to a sauce-pan in front of him, while a ribbon from his mouth contains his last speech and dying confession: "If you want to see me jump in there, pop in here."

There is no odder, there is no more attractive, part of Paris than the quays which lie from Port Royal to Pont Neuf on the south bank of the river. Here on the parapet of the wall which separates street from wharf (the latter is fifteen or twenty feet below the street) are boxes filled with second-hand books. Unless you are a known customer, you cannot enter the regular book-shops of Paris and take down the volumes you desire to examine. Some of the most interesting of these shops are on a second floor, and a woman is generally the keeper. A spring bell announces your entrance, and she comes forward and in a surly tone challenges you with: "What do you want?" If you cannot tell the book you wish and the price you are willing to pay, she will let you know bluntly enough that you are not wanted. There are some shops on the ground floor which bear on the door, "Free admittance." Do not trust it any more than you would the "Walk in, Mr. Fly!" seen on the door of a musical café, where, as you know, the instant you appear a waiter pounces on you with: "What shall I serve?" On the quays it is different. If you turn over the volumes from morning till night, nobody will say anything to you. Do not judge the quay's wealth, however, by the afternoon's store. They are richest in the morning. Book auctions commonly take place at night, and purchases are put in boxes before noon; so that it is in the early hours of the day that book hunters give chase. In the afternoon you see only their leavings, save the casual purchases made from student, or literary man, whose divorce from his books has been decreed by hunger. It is then that servants bring books to be sold—books discarded as dull, or left behind as too heavily handicapping railway luggage. Again, large casual sales sometimes lead to the discovery of treasures, for there is not one of these book-sellers, though they are as sordid as the Apothecary in "Romeo and Juliet," who has not a large warehouse filled with books, to which he will admit you, when he has made the acquaintance of your purse.

I find great amusement in these boxes, reading odd French translations. Here is Chateaubriand with "Siloa's brook that flowed *rapidly* by the oracle of God." A translator of "Othello" did "Handkerchief! O Devil," into "Tissue formed of finest threads and doomed to basest uses! O monarch regnant of the infernal regions!" This dilation of the author's phrase is due to the weakness of the French language. I read with astonishment authors who extol this tongue above our own for clearness, accuracy, elegance of expression. This praise is altogether unmerited. The admiration of periphrasis, and the aversion to using the same word twice on the same page, make the language extremely obscure. Until the Romantic school of 1830 tore some swaddling clothes from France, no French author dared speak of a cab except as "a numbered chariot," or of the ocean, except as "the bitter liquid plain." In a French translation of "Uncle Tom's Cabin," a "load of lumber" was rendered a "load of odds and ends of waste." I have seen pine-burrs translated pine-apples; the Leeward Islands given *les Iles de Leevard*, evidently on the supposition that they had been discovered or owned by Monsieur Leeward, and the Windward Islands, "the Islands under the Wind." I noticed in a book-seller's catalogue, "Indiana, its Topography," etc., set down among the *anas* with Seldeniana, Baconiana, etc., and in another list Paul Ding's works. A French scientific work gives us the information that the Falls of Niagara supply motive power to the flour-mills at Minneapolis, and

that every moonlight night, thousands of boats are to be seen on the Mississippi, filled with ladies and gentlemen from New Orleans, who row to the Gulf of Mexico, enjoy the sea-breeze and return before early bed-time. Another Frenchman translated Koenig, the name of the writer, as Frederick the Great. And still another rendered *asseres*, the rafters of a roof, as if it had been *anserres*, a flock of geese, and gravely told his countrymen that flocks of geese built swallows' nests under roofs, instead of telling them that swallows built nests in roofs' rafters. I have seen "Out! out, brief candle!" translated "Get you gone! To the door, short piece of candle!" And everybody has heard how "All hail!" has been done into French as "Nothing but hail-stones!"

It is another oddity of Paris that the higher you go upstairs the lower you go down in society—as if social status were decided by a jury of wheezing, asthmatic fat men. It is an oddity of Paris to buy wood by the pound; to be obliged always to pay something over and above the price agreed upon; to be obliged to carry a paper in your pocket under pain of arrest, avouching you to be an American; to have no pump but only a stone jar in your kitchen, and to see it filled every day by a man who brings water upstairs on his shoulder and gets two cents for each pailful; to see carpets nowhere, while clocks, and mirrors, and gilt candelabra are everywhere; to find everything, except mere lodging, an extra: towels, water, chimney-sweeping, boot-cleaning, candles, ice.

TOPICS OF THE TIME.

Sunday Bumsers.

THE poor we have always with us, and whenever we will we may do them good. And the will to do them good, in a spiritual and religious sense, at least, is very genuine and very abounding. The churches, as a rule, cherish no desire more sincere than that of preaching the gospel to the poor, without money and without price. We do not stop to inquire how much of the proselyting spirit may be connected with this desire, or what worthless motives may sophisticate it. Their wish to do good to the poor is genuine enough, and to do it at their own expense. If the poor could know how heartily they would be welcomed in houses of worship frequented mainly by the rich and the well-to-do, they would certainly lose their shyness, and learn a kindlier feeling for those more fortunate than them-

selves. It is undoubtedly the business of the rich to provide religious privileges for the poor, and the duty of the poor to accept them. They may do this without loss of self-respect, and without the cultivation of the pauper spirit.

There is, however, a real difference between "God's poor" and man's poor. There are great multitudes who, do what they will and what they can, must always be poor. Few and inefficient hands to labor, and many mouths to feed, sickness, misfortune—all the causes of adversity—produce poverty which seems to be remediless; and those who are afflicted with such poverty may legitimately be called "God's poor." These are the involuntary poor, enveloped and embarrassed by circumstances which render it impossible for them to rise out of poverty. For these, the Christian man will do what he can, without

pauperizing them, and he knows that there is no form of beneficence so little likely to do them harm as that of providing for their religious instruction and inspiration. He knows also that the rectification and elevation of habits which are the natural outcome of religious and spiritual influences, are ministers always to the poor man's temporal prosperity.

In contradistinction from these, there are those whom we may properly call "man's poor." They are people who spend upon themselves, out of an income not generous, perhaps, but competent, so much that they have nothing left with which to bear their portion of the burdens of society. They live well, they dress well, they maintain what they consider a respectable position in society, they go to the theater whenever it may seem desirable; they spend upon themselves and their luxuries their entire income, and habitually steal their preaching. Many of these people are quite regular in their attendance upon the Sunday services of the church, but they never unite with it, or assume a single responsibility connected with it. There are churches in New York, as we presume there may be in most cities, which are the favorite resorts of the bummers—churches which, by the numbers in attendance on Sundays, seem to be prosperous, but which, from the fact that they are so largely made up of bummers, cannot support themselves or their pastors. These worshippers make a very well-dressed congregation, but they offer a very poor field for preaching and pastoral work. They do not even introduce themselves to the pastors to whose preaching they listen. When they become a little ashamed of this Sunday bumming at one church, they go to another. The sexton knows them at last, and understands exactly what they are and what they are doing. A little self-denial would give all these people the right to a pew, and save them from the meanness of appropriating that which honest people are obliged to pay for.

Now, there is nothing in the world better calculated to bring dry-rot into character than this Sunday bumming. To go week after week to church, assuming no responsibility, paying for no privilege, and taking no part whatever except that of a thief or sponge, can have no influence better than that of unfitting a man for society. He who is not one of God's poor has no right to privileges that he does not pay for, in or out of the church, and the man who becomes willing to avail himself of the generosity of others, in order that he may spend more upon his artificial wants, becomes a pauper at heart and a thief in fact.

The great majority of Sunday bummers ought to be ashamed of themselves, for even their church-going very often grows out of their love of respectability and of the usages of respectable society. But the young, and particularly young men, should be warned against the practice. The Sunday bummer is nearly always the occupant of a boarding-house, a fact which at least partly accounts for his demoralization. We do not think it often happens that the occupant of a genuine home steals his

preaching. All sorts of moral obliquities and social loosenesses are generated in boarding-houses—and Sunday bumming among the rest. A man without a home is a pretty poor member of society, as a rule. It is not apt to occur to him that he has any stake or any duty in society, so he takes what society gives him, and avails himself of the privilege of squatting upon the rest. Young men coming to the city to live—for it must be remembered that the Sunday bummer is peculiarly the product of the city—should by all means avoid a habit which will always tell against them. The first thing a young man starting out into independent life should do is to take squarely upon his shoulders the social burdens that belong to him. The policy breeds manliness and self-respect, and will remove him from all liability to become the poor creature known as the Sunday bummer.

Teachers and Task-masters.

WE are sorry for the man who did not have, at some period of his childhood or youth, one teacher who filled him with the enthusiasm of study, and brought him into love with knowledge and into a genuine delight in the use of his intellectual powers; one teacher—to state it briefly—who understood his business. For, with all the advances made in the theories and methods of education, and all the elevation of educational standards, it is, and remains, true, that the poorest work done in the world is done in the school-room.

In the first place, there is no competent idea of what education really is, in the average teacher's mind. His whole training has misled him, and his own instincts and common sense have in no way corrected his educational influences. His work has been the careful and industrious memorizing of the materials of his text-books, and he has no idea of educating others except by the same process. He has never been taught; he has simply been tasked. He is, consequently, a dry man, without enthusiasm and without ideas; and the work that he does is simply that of a task-master. A preacher, in order to succeed, must not only be an enthusiast, but he must be profoundly interested in the kind of material that comes to his hand to be molded and influenced, and in the processes through which he acts upon it. He exercises all the ingenuities of address and handling to win attention, and is never satisfied until he has awakened a profound interest in the topics that engage his efforts. Every live preacher has his own way of work, and accounts it a misfortune to find himself lapsing into the mere mechanisms of his profession. So unlike him is the average teacher, that a pupil is always surprised to find him an interesting person, who gets outside of his mechanical routine of duty. A teacher's duty, as it is commonly understood, is to keep order and hear recitations. Beyond this, he is to mark progress in education, as he most incompetently understands it, by arithmetical formulæ. Nothing more uninteresting and mechanical can be imagined than the usual routine of school.

Parents often wonder why their children are not interested in their studies. Why! in the way in which their studies are conducted, it is quite impossible that they should be interested. The marvel is that they have sufficient interest in their tasks to pursue them at all. Machine education is no more interesting than machine preaching. It is simply a long, dry grind, which children are glad to get through with, and upon which they look back with anything but pleasure and satisfaction.

The ordinary teacher will naturally inquire what we would have. It is very hard to tell an incompetent man what he cannot himself see, of the requirements of his own calling; but we have a very definite idea of what we desire and of what we believe to be needed. In the first place, no pupil should ever undertake a study to which he has not been properly and competently introduced. The nature of the study, its relations to all other study and to life, the proper methods of pursuing it, the literature connected with it,—all these should be presented and explained in such a way that a pupil on beginning has some idea of what he is undertaking, and the reasons for his undertaking it. Then, from this time, the educator is to remember that he is less a task-master than a teacher, and that if his pupils do not get along well, it is mainly his fault. If they have been properly presented to the study, and their way into it has been made interesting by his intelligent and enthusiastic leading, they will be interested; otherwise, not. We have known pupils to go through years of study in the mathematics without understanding anything as they ought to do, and, at last, to bring their study to a most fruitless and unsatisfactory termination, simply because they had a teacher who regarded himself as only a task-master, and would never take the time and pains to teach them and make the steps of their progress plain. No man is fit to teach who will leave a pupil floundering in and through a study for the want of intelligent help and direction. It is a teacher's business to teach, and not to leave his pupils to find out what they can themselves, and hold them responsible for their own instruction. Education is not the result of memorizing facts, nor wholly of understanding and arranging them, of course; but so long as we study text-books, and practically record our progress by means of them, there is no such inspirer as an intelligent, sympathetic and enthusiastic teacher.

The public have not held teachers to their true responsibility. We send a young lad or a young girl to school, and find that, while we are paying out a great deal of money for them, they are gaining nothing. We complain, and are informed that our children are not industrious, that they do not seem interested in their studies, that they are absorbed in play, etc., etc. In ninety-nine cases in a hundred, our disappointment is entirely the fault of the teacher. He or she is simply incompetent for the duty they have undertaken. A first-class teacher always has good pupils. Lack of interest in study is always the result of poor teaching. We send a boy to college, and find that he regards his studies as a

grind,—that he is only interested in getting good marks, and that he is getting no scholarly tastes, and winning no scholarly delights. We inquire, and find him in the hands of a young tutor, without experience, who really pretends to be no more than a task-master, and who knows nothing, and seems to care nothing, about the office of teaching. The placing of large masses of young men in the hands of inexperienced persons, who do not pretend to do more than to set tasks and record the manner in which they are performed, without guidance or assistance, is a gross imposition of the college upon a trusting public, and it is high time that an outcry so determined and persistent is raised against it that it shall procure a reform.

The Sermon.

WE hear, in the different pulpits, a good many sorts of sermons in these days, and from the pews we hear a good many theories and ideas about sermons. In the ministry of the Christian religion, the sermon seems to be of growing importance, among all sects. The forms of worship vary very little. Each sect has its prescribed, or voluntary and yet habitual, formula of prayer and praise, to which it adheres, generation after generation. It makes more or less of singing at different times, and has its liturgical spasms; but, on the whole, each sect adheres to its form of worship with great tenacity and steadiness. The sermon, however, is subject to great changes, and is the result partly of the general culture of its time, and partly of theories of preaching entertained by the church.

The Episcopal Church in this country, like its mother in England, is inclined more than any other denomination, except the Catholic, to make much of the service and little of the sermon. The average sermon that one hears in the established church in England, as in the English continental chapels, is only a brief and unimpressive homily, written with great propriety, and delivered not only without passion, but without the slightest attempt at oratory. To a man thirsting for religious impression, or for intellectual stimulus, nothing drearier, or more unrewarding, can be imagined than this kind of performance. Much more is made of the sermon in this country than in England, however, and the Episcopal Church could not hold its own, and grow in importance and influence as it does among the American people without a better sermon than prevails in the English Church. The Brookses and Tyngs are among the most impressive preachers we have, and the Episcopal sermon is now generally like the sermons of the other sects—full of intellect, vitality and eloquence. Still the leaning is toward the service, as the thing of paramount importance.

In all the other denominations, however, the sermon is the supreme thing. The prayers and the music are simply preliminaries and supplementaries to the sermon. The point of first interest is the topic, in its announcement; and the question as to whether the attendance at church has paid is determined, almost entirely, by the character of the dis-

course which follows. Whether this partiality to the sermon is right or not, we do not care to judge. We take the fact as it stands, for the purpose of saying a word on the kind of sermon demanded in these days. Among preachers who are not "sensational," as the word goes, we hear a good deal now about and against "sensational preaching." We confess that we like sensational preaching, if by the phrase is indicated that which produces a sensation. If by this phrase, however, it is intended to indicate the kind which is accompanied by theatrical tricks, and startling phraseology, and rough pulpit manners, we dislike it as much as any one can. A clown is never more out of place than when he is in a pulpit; and we may add that the true orator is never more in his proper place than there. A man who has the power to wake up his audience intellectually, to rouse their sympathies, to address them by motives so powerful as to exalt them to determination or to action, is the true sensational preacher. This is the man who attracts a crowd; and the man who can be relied upon to do this every Sunday, is the man who holds the crowd.

A great deal of fault is found with "intellectual preaching," but it is pretty well understood now that nothing else will be attractive. The world knows its duty well enough now. The sermon that is simply good, that is charged only with the commonplaces of religion and morality, and never rises into eloquence or a high range of thought or feeling, might almost as well go unpreached. It accomplishes little beyond disgusting its hearers with going to church. The obvious, common things that may be said about any given text of Scripture, are exactly the things that ought never to be said in the pulpit, for in these things the pulpit is no wiser than the pew. One of the great reasons for the lack of popular attraction to the pulpit lies in the fact that brains enough are not put into the sermons. The thinking in a sermon must be superior to the average thinking of an audience, to produce any effect upon it, and if, in these days, any man—no matter how gifted he may be—imagines that he may halt in his enterprise of earnest and profound prepara-

tion for his preaching, without damage to himself or his work, he is sadly mistaken. His slipshod stuff will be detected every time, and pass to his discredit.

We know of no profession or calling so exacting in its demands as that of the pulpit; we know of none that is capable of winning greater rewards of influence and affection, but in these days the pulpit is a bad place for a lazy man, or one who is inclined in any way to underrate the popular intelligence concerning both his profession and himself. Goodish homilies have gone out, and high discourses have come in. The best thinking that the best men can do, the best English they can command, and the most impressive delivery of which they are the masters, are called for, every time they appear before those who have sufficiently loved and trusted them to place them in their high office. The public are not deceived. No facility of words can cover sterility of thinking. A preacher who does not do his best every time is in constant danger of doing himself irretrievable damage.

There are certain economies of pulpit oratory that demand more attention from our most successful preachers of sermons. It is a great temptation to a powerful man who finds a plastic congregation in his hands, to continue his conquest of conviction and emotion beyond the point of triumph. There is a charm in mastery which leads to long sermons—to talking after the sermon is done. This breeds uneasiness, and always detracts from the best result. It is always a mistake, and we know of a dozen eminent men who are constantly making it.

After all, the best and most important qualifications for preaching a good sermon is an overmastering belief in Christianity. There is so much preaching done that leads to admiration of the preacher rather than to faith in and love of Christ, that earnestness cannot be too much insisted on, or too highly estimated. So it is an excellent thing for a preacher to be a Christian, if he desires to accomplish by his preaching anything beyond his own elevation.

HOME AND SOCIETY.

General Principles of Cookery. I. Boiling.

It is not intended in these papers to give general receipts. Such as may be given here are meant to illustrate general principles of cookery, or else to meet such difficulties as cookery books often raise; the papers are meant to aid rather than to supersede more formal directions. A good cookery book is a useful ally to the most experienced cook; to the tyro it is usually but a blind guide; without a knowledge of the first principles of cooking this is inevitable. Who does not remember poor Bella in

"Our Mutual Friend,"—her elbows on the table, her temples in her hands, consulting with all the eager zeal of a newly-made matron the "Complete British Housewife," and, finding her poor little brains quite unable to cope with the sibylline mysteries therein propounded, exclaiming—

"Oh, you ridiculous old thing, what *do* you mean by that?"

The few rules, a knowledge of which make successful cooking from a book easy, can fortunately be briefly explained and easily remembered. The plain boiling, roasting, frying, and stewing are what

make really good cooking; and it is safe to say that the woman who knows how to do these well need never fear for her dinner table.

Boiling we take first, because it is the branch of which people seem to know least.

How rare it is to find this simple operation well done! How often we hear it said of boiled beef or ham, for instance, "Fine flavor, but so tough," and how few people know that the toughness proceeds, in nine cases out of ten, from quick boiling! In the case of ham, that most abused of all joints, and perhaps the easiest of all to cook, your cookery book probably tells you to boil it slowly four, five, or six hours, according to size; and people usually interpret this direction into putting the ham into the pot, and letting it boil at what is actually a slow gallop for the given time; while very often, if entrusted to a cook, it boils only at intervals. So that it remains on the fire a given number of hours, Biddy thinks the boiling is done. Ham should not boil, it should merely simmer. A fair-sized ham put on at ten in the morning, if properly cooked, should be done and tender by four or five in the afternoon. The water should be brought to the boiling point, the pot then be set back on the stove, and the water be allowed to simmer—but remember, it must never be *below* boiling point, nor scarcely a degree above. The ham should be turned in the water once or twice during the time it is on the fire. When sufficiently done the rind should be stripped from it, and the ham well dusted with sifted bread crumbs, made by baking slices of bread in a slow oven until they are of a fine golden brown all through, and dry enough to powder under the rolling pin. Never stick your ham with cloves; it suggests flies, and spoils the flavor for many tastes. A pretty finish is given by dusting it well with sugar instead of bread, and then passing a hot knife over it until it has melted and coated the ham with a caramel glaze. A much finer way is to glaze it with strong meat jelly, or any savory jelly you may have, boiled down rapidly until it is like glue, taking great care during this boiling-down process to prevent burning. This jelly should be brushed over the ham when cool; it makes a handsome dish of a plain one.

The same rule of boiling holds good with beef. Corned beef is generally a hard, salt, dry fare; but, properly cooked, it should be more tender than roast meat, and almost as juicy. That any boiled meat shall be tender, it is necessary to remember that the process must be slow. Different people have made such different interpretations of the expression, "slow boiling," that it will be well to be explicit. Most people think that if the whole surface of the water is in a state of slow ebullition, this is slow boiling. For boiling meat, a great French authority gives this rule, which I have found excellent: The ebullition should only appear in one part of the surface of the water, and there be only just visible. This is, however, distinct from stewing, or simmering, which is yet slower, there being in that

process no ebullition, but merely a sizzling on one side of the stew-pan.

Authorities differ as to whether meat should be put into hot or cold water; many books omit all direction on this subject. My own rule is to plunge fresh or slightly salt meat into boiling water, in order to retain the juices. For this reason highly salted or soup meat I put into *cold* water, that the salt in the one case, and the gravy in the other, may be drawn out.

What has been said about the boiling of meat does not apply to vegetables. For them, with few exceptions, quick boiling is necessary. It may be taken as a rule that all green vegetables, such as cabbage, Brussels sprouts, string beans, etc., should be boiled quickly in abundance of water.

Cabbage, as usually served, is a coarse, rank vegetable, while properly cooked, fresh cabbage is as delicate and delicious as cauliflower. Cut it into four or six pieces, put them into a large saucepan with plenty of boiling water, and let them be brought quickly to the boiling point and kept rapidly boiling with the cover off, pushing the leaves down with a spoon as they rise above the water. Let it boil thus until quite tender, but no longer, as the vegetable then loses color and flavor, and becomes rank, yellow, and wilted.

N. B.—This method of allowing abundance of water and space, together with quick boiling, does not apply to peas, spinach, and asparagus.

Peas only require moderately quick boiling, in sufficient water to cover them, to which has been added a spoonful of sugar, not enough to sweeten, but only to replace the sweetness the water has taken away. English people always add a small bunch of fresh mint.

Asparagus requires special care, and after it has been scraped and trimmed (cutting an inch or two, if it is long, from the root end) it should be tied in bundles and put to stand in a deep saucepan, with water just reaching to the tops. It should then be boiled with moderate quickness until done, *i. e.*, for about twenty minutes. You will then find that you can take it up without losing one of the frail heads, and the flavor is much fuller than when these have been soaked by lying down in the water. Always have a slice of toast at the bottom of your vegetable dish for asparagus or cauliflower: it drains those delicate vegetables better than you can otherwise do without injuring them. Serve with a fine white sauce, and as this is seldom well made, I will, in a future paper, give two unailing receipts.

Spinach is another vegetable that is rarely well cooked; it is of such a watery nature that it should be put into the pot in which it is to be boiled without water; it will soon make enough liquid with its own juice; when tender, take it out, chop and season it; meanwhile allow the juice that remains in the saucepan to boil down; then return the spinach to it, and stew until the excess of liquid is evaporated. Put less salt to this vegetable than to others. It is hardly necessary to say, perhaps, that salt must always be boiled with vegetables.

Puddings are not so much in favor here as in England; yet English cookery books are not uncommon with us, and many a housewife, allured by the toothsome receipts of some of the English boiled pudding, tries say a plum-pudding, and ever after has a lively recollection of it as a sticky, leaden mass, and wonders at the depraved transatlantic taste. The cause of many failures is, that the pudding has ceased to boil during the process of cooking. It cannot be too often reiterated that everything that has to boil, *must boil the whole time*. Just as soon as the water falls below boiling point it begins to soak into the pudding, meat, or vegetables; hence the heavy, sticky result. Never boil a pudding one minute less than the time prescribed in your book; long boiling is essential to lightness.

Fish requires great care in boiling. Small fish should be put into cold water, large fish, such as salmon, into hot, with salt and a tablespoonful of vinegar to every quart of water. You can tell whether it is sufficiently done by inserting the blade of a knife in the back of it; if it leaves the bone it is cooked. Fish should boil *slowly*. If you have no fish kettle, put a plate on a square of thin muslin, lay the fish on the plate and tie the muslin by the four corners, and put plate and all into a sauce-pan. You can then lift the fish from the water without breaking.

CATHERINE OWEN.

The Boys of the Family.—VI.

HOW TO BECOME A TELEGRAPHER, AN ENGRAVER, AN ARCHITECT.

It is usually a sense of personal disappointment, rather than any better reason, which impels the practitioners of many professions to discourage those who seek information as to the prospects of a beginner. Few men, indeed, are so well satisfied with their occupation that they are disposed to speak favorably of it, and in many instances they view it from the embittered stand-point of their own unrealized ambitions. "Don't let your boy be an architect; don't let him be an engraver; don't let him be a telegrapher. Choose some other employment for him; ours is hopeless." The unanimity of the discouragement is perplexing, and it is usually unjustified; for, while many occupations do not lead one to a competency, they at least insure a respectable livelihood for those who engage in them faithfully and industriously; and, though more brilliant things may be hoped for, a respectable livelihood, in the decline of life, is more than half the world obtains for its labor. A special order of abilities, concentrated and exerted in a proper direction, are the essentials of substantial success, of course; but there is much ability adrift in the world that is adaptive, and there are many boys who, not having a "call" to a particular profession, are willing to accept any situation that offers. No eminence can be attained in architecture or engraving without special abilities; immense executive ability is needed in the chiefs of the telegraph service. But the last generally requires a more common order of qualifications than the other two; and, though these three occupations are not in the least affinitive, I have embraced them in this paper,

since a representative of each spoke to me deprecatingly of his profession without—it seems to me—sufficient cause.

TELEGRAPHY.

There are various schools of telegraphy in all large cities, which advertise attractively for pupils and promise situations for their graduates. But all of these are repudiated by the managers of the telegraph companies and by practical operators, who not only say that the schools have no influence whatever in procuring situations, but also that the training they impart is of no real advantage. There is one exception in the classes of the Cooper Union, which are instructed under the auspices and supervision of the Western Union Company. They are formed exclusively of women, and the tuition is entirely gratuitous. The graduates are taken into the employ of the Company at salaries of twenty to twenty-five dollars a month. But the announcements of other schools, conducted by private persons, are misleading, and the fact that a young man has attended one would not add the least weight to his application for an appointment as operator. It is not that the knowledge of the instrument and its manipulation which he acquires is useless, although the practical application of it is very different from the theoretic study; but he is possessed by a sense of completeness which unfits him for the proper subordination of a beginner, and much that he has learned is an encumbrance, of which he must be relieved before he can adapt himself to the circumstances of a good operator.

There are probably not less than twelve thousand operators in the United States, of whom nearly two hundred and fifty are employed in the main office of the Western Union; and the salaries paid range from twenty to one hundred dollars a month. Very few of them have attended schools of telegraphy, or had other instruction than that which they have "picked up" while performing other duties in telegraph offices. Many of them have been messengers, and have qualified themselves for the higher position by studying the sounds of the instruments while waiting for assignments. Others have been office-boys, who learned in the same way—nearly every office in the country has a boy or two in tutelage. The most expert are almost invariably self-taught. Four perfect instruments are set apart, in the operating department of the Western Union office, for practice; and, when the work of the day staff is over, at half-past five o'clock in the afternoon, any ambitious boy in the office may sit down at these and learn how to operate them. Having begun work at eight o'clock in the morning, he may not feel disposed for further exertion; but his advancement will depend on his persistence. The simplest letters soon become intelligible, and by degrees the tickings of the instrument are as coherent and fluent to him as print. While he is familiarizing himself with the instrument, he is also learning the technicalities and details of the office, and their reality impresses them in his mind, which would not be the case were they nominal and fictitious, as in the so-called schools. When he can transmit and receive messages accu-

rately, he is occasionally allowed to work on the less important wires during the dinner hour, or during an unusual pressure of business; but it is probably four or five years before he is classified as proficient, and it is the opinion of Mr. Warner, the chief operator of the Western Union in New York, that not more than one person in ten who learns telegraphy ever ranks as a first-class hand. Entering the operating room, a boy is paid about twenty dollars a month, and his hours are from eight o'clock in the morning till half-past five in the afternoon, with only a twenty minutes' intermission for lunch. In a year or two he may be worth forty dollars a month, and his promotion depends, of course, on the facility and accuracy which he displays. There is no brilliant opportunity, no career of great promise; but there is an occupation, with fair remuneration, to which many persons are adapted. Perhaps in the future women will supersede men as operators, and—overlooking the irregularity of their attendance when they are not quite well or the weather is stormy—the men with whom they are placed in competition and the chiefs of the service regard them favorably. Some of the former, who have families to place, show a disposition to let the girls become operators and to find other employment for the boys. But if, after learning telegraphy, a young man is diverted into another business, his ability to manipulate an instrument is likely to be serviceable to him. In journalism, in railway affairs, and in nearly all large commercial establishments, this accomplishment is available, and it may help to advance him and secure an increase of salary.

ENGRAVING.

The extraordinary progress made in the graphic arts of late years, the multiplication of popular illustrated works and periodicals, the tendency of large firms and corporations to use pictures instead of letterpress in advertising their commodities, are trustworthy indications that the business of an engraver is now more than ever before a promising field for a beginner with an aptitude in that direction. But if we accept the statement of the engravers themselves, without an allowance for that sense of personal disappointment and weariness which we have previously spoken of, no occupation is so barren of inducements as this. They are more emphatic than the telegrapher, the architect, or the soldier in saying, "Don't put your boy to our trade; turn his footsteps in another direction." As a matter of fact, the standard of a successful engraver is higher now, and the necessary qualifications greater, than hitherto. Formerly, the office drudge, without education of any kind, and without any definite intelligence or aptitude, was allowed to practice at blocks in his spare hours; and, by degrees, he acquired a certain mechanical facility that qualified him for a position in which he hacked out whatever beauty and softness the drawings intrusted to him had. He was the bane of artists, not having the capacity either to understand or to interpret them. But the art revival has compelled a change; and, besides perspicacity and manual facility, the engraver who would succeed must have a knowledge of draw-

ing and color and a sympathetic understanding of the work submitted to him. For this reason, a young man, ambitious of becoming an engraver, should have some preliminary training in art, and, we might almost say, should be a finished draughtsman before he attempts the sister profession. But even supposing that he has an education, that he can draw and has art sympathies, he must in most cases enter the office as a subordinate and carry the burden of many profitless details before he is afforded an opportunity to develop in the direct line. He is received in the office as a boy, with a salary of three or four dollars a week. Eventually, superior equipment and intelligence will be recognized, and with ordinary talent one may obtain a lucrative and honorable position. The salary of an engraver is from twenty to fifty dollars a week, but a master hand of positive ability and experience commands four or five thousand a year. This profession is also adapted to women, and two or three have already acquired high rank in this country.

ARCHITECTURE.

In architecture, which also is unpropitious in the opinion of its followers, the conditions are wholly different from either of the previously mentioned occupations. In such a country as this, where material progress at least is unintermittent, and where the most familiar expression of it is (generically speaking) in elaborate piles of brick and mortar, one would expect the architect to be a man of high prices and large profits, if not of invariable good taste. But the few who are pre-eminent, who have influence, reputation, varied experience, and great ability; who have invested money, as well as other capital, in their businesses, do not often reach greater profits than ten or fifteen thousand dollars a year. Many more have much less, and the majority, who are fully qualified, but without capital or influence, do not receive as large salaries as the practitioners of other professions who have relatively the same education and degree of talent. To enter an architect's office with a reasonable prospect of success, a boy must have definite abilities, and a sound technical education, such as may be obtained at the Rensselaer Polytechnical Institute at Troy, the Sheffield Scientific School at New Haven, the University of Michigan, the Stevens Institute, or the Massachusetts Institute of Technology. Courses in architecture have also been introduced in Yale, Columbia, and the College of the City of New York. All of these schools provide suitable training; but the Massachusetts Institute devotes itself to the education of architects more than the others. It would be possible, of course, for a young man to find a situation in an architect's employ without the expensive preliminary education; but the competition with his companions who possessed it would be so great that he could only succeed by desperately hard work and an uncommon order of abilities. The salary of a beginner is small, even when he has been graduated from a college or technological institute; but it is usually sufficient to support him, and after a few years it is increased to twenty or twenty-five dollars a week. WM. H. RIDEING.

CULTURE AND PROGRESS.

A Portfolio of Proof Impressions from "Scribner" and "St. Nicholas."*

CATHOLICITY is a virtue upon which the management of SCRIBNER and ST. NICHOLAS can with fairness plume itself. Employing a great number of artists for their illustrations, the managers have not confined their choice to representatives of any one school of art, whether in regard to the original draughtsmen and painters, or in regard to the artists who have engraved their cuts. A great deal of rubbish has been talked about legitimate and illegitimate engraving, in most instances by persons who know little or nothing about the subject. SCRIBNER'S MONTHLY has been open to experiments of all kinds, as to the limits of the art, but has never made itself a champion of a "process," nor even taken a position adverse to older engravers and in favor of the younger generation. Believing that each should stand upon his own merits, the magazine has been open to the most extreme believers in "pure line" engraving, as well as to those who admit more latitude in the mechanical work of the engraver. That this is true may be proved by the *résumé* of remarkable engravings now collected from the two magazines, and issued in a handsomely bound portfolio. About three-quarters of these pictures are from SCRIBNER'S MONTHLY; the others from ST. NICHOLAS. Both ancient and modern schools of art will here be found represented. There are specimens of pure line engraving, stipple and cross-line engraving, and examples of simple fac-simile work occur alongside of pictures finished in the latest styles of "wash." There are few artists of note, and still fewer engravers, whose names do not appear in the table of contents. Reproductions of ancient and modern pictures form a salient feature of the list and offer a chance to obtain mementos of celebrated works of art which have something besides the mechanical exactness of the photograph to recommend them. The wood-cuts are charged more or less with the personality of the engraver, according as the latter may have inclined toward literal fidelity to the original, or a freer and bolder handling.

The Portfolio is to fill a demand which has existed ever since the development of interest in magazine engravings, and to which the publishers have heretofore been unable to respond, viz., a demand for choice proofs of the most attractive illustrations which, being printed separately on fine paper, can be framed for the wall. It will consist of about one hundred plates, 13½ by 11½ inches, printed on paper made expressly for the purpose, with a tinted margin around each picture to take the place of a mat when framed. The presswork has been done with the greatest care, and the printers of the magazine regard it as the finest printing of wood-engravings so far

attempted in this country. It has taken since the first of last June to print one hundred pictures. The binding will have upon the cover a design by Francis Lathrop, consisting of antique bass-reliefs of the heads of Gutenberg, Bewick, and Holbein.

The selections include the best pictures that have appeared in the magazines since the foundation of SCRIBNER in 1870. Of the portraits of eminent poets and statesmen by Wyatt Eaton, those of Bryant, Holmes, and Lincoln have been chosen as being the most successful of the experiments in reproducing ink and crayon drawings. The beautiful illustration by John La Farge of the "Wind-Harp;" Mr. Cole's reproduction of the portrait of the Countess Potocka, and the same engraver's rendering of Fortuny's "Piping Shepherd," are of the number. Many exquisite wood-cuts by Marsh and J. P. Davis show the position which these engravers hold in the art. The style of Mary Hallock Foote can be compared through a number of original drawings extending over several years, and engraved by different hands, including Mr. Linton and Mr. Anthony. Kelly's "Gillie Boy," engraved by Cole, can be confronted with the portrait, the Strawberry Girl, by Sir Joshua Reynolds, cut after the strictest rules of engraving by J. G. Smithwick. Here are also the delicate pictures of the altar-piece modeled by St. Gaudens for St. Thomas' church, and the pilasters of the same from the studio of La Farge. There are, among other well-remembered illustrations, the reproductions, by Cole, of Kämmerer's "Wedding under the Directory," and "The Last Token," by Gabriel Max, "On the Edge of the Orchard," by R. Swain Gifford, and other remarkable blocks engraved by King, "The Young Marsyas," the beautiful portrait of Modjeska, examples of James Beard's birds and fish, Vanderhoof's "Ship Chandlery," reproductions of bass-reliefs by O'Donovan, Mr. Juengling's portrait of Whistler, choice selections from the Tile Club articles, the unusually popular "Ready for the Ride," by William M. Chase, some of Dielman's charming drawings from ST. NICHOLAS, reproductions of Leonardo da Vinci's "Head of Christ" and "Last Supper," several of Abbey's drawings, "Bringing in the Boar's Head," by F. B. Mayer, the charcoal sketch of John Howard Payne's birthplace by F. Hopkinson Smith, Miss Powell's vigorous engraving of Chapu's bronze "Gratitude," "The Sisters," from the painting by William Page, and cuts of unusual beauty and excellence by Kruell, Muller, Wolf, Nichols, Whitney, Heinemann, Bookhout, and many others. Indeed, whoever has wished to own a fine proof of any of the most important illustrations of the two magazines during the last five years, will find his desire gratified by this publication, which may truthfully be said to embody the highest progress made by America in the only one of the arts in which she incontestably excels.

* A Portfolio of Proof Impressions. Selected from Scribner's Monthly and St. Nicholas. New York: Scribner & Co.

Joyce's "Blanid."*

AMONG the legends of ante-Christian Ireland was that of an association of knights like the famous Round Table of King Arthur in Britain. There are not wanting persons of weight who hold that the Irish tradition is the older of the two, and that the Knights of the Red Branch were the prototypes and perhaps the models for those creations of the British imagination—creations, it may be said, not without a solid nucleus of historical truth, but so surrounded and overlaid by mythological and magical lore, that their right to historical existence need not be considered. Indeed, it is quite true that the Irish legends have a stamp of archaism which the Arthurian legends lack. They approach nearer to the fragments of the Arthurian ballads in other Celtic regions, such as those discovered in French Brittany by Villemarqué and others, and in Scotland, in very mutilated form, by Bishop Percy. There is a terseness and strength of individuality about them which the more ornate Welsh ballads, from which Tennyson has drawn his material, have not preserved.

Now as Lancelot du Lac is the strongest and bravest peer of the Round Table, so Cuhullin, the hero chosen by Dr. Joyce for his second epic, is the champion of Red Branch Knights. Like Lancelot du Lac, and Tristram as well, he was enamored of a woman who is forced to marry another, and Blanid, the woman he loves, is, like Guinevere and Iseult, unfaithful to her husband for his sake. But in the sequel Blanid acts toward Curoi, who is a devoted spouse and also a stronger warrior than Cuhullin, with a treachery and ferocity that are in startling contrast with the loveliness of her two erring sisters in legendary lore, Iseult and Guinevere. In this Dr. Joyce has only followed the legend; he is forced to show the savage, uncivilized character of the groundwork on which he has built his poem. The woman Blanid—the Bloom-bright,—believes the nature which is given her by the poet, by proving even bloodthirstier and viler than the ferocious warrior-woman Brunhild in the Nibelungenlied. The difficulty arises because on harsh lines Dr. Joyce has fitted a flowery, luxurious epic, that belongs in its nature to a period nearer to Spenser than to Ossian. Nothing in the character of Blanid, as she is described in act and speech during the long poem, prepares us for such a cold-blooded and monstrous crime as the murder of Curoi. This is because all the first part is Dr. Joyce's alteration or addition, while the plot belongs to the old legend first written down in the last century by the Irish scholar Keating, for ultimate translation into English.

The scene opens. Blanid, the exquisitely beautiful and renowned daughter of a rich and haughty king of the Isle of Man, who has strayed from the hunting party, is about to be trampled to death by a wild bull. Cuhullin, of the Red Branch Knights,

happens to arrive in the nick of time, and as she swoons, slays the beast:

But he was there, that hunter beautiful,
Cuhullin, Eman's noblest Red Branch Knight;
He raised her gently up, and in the lull
Of her short swoon kissed face and forehead bright,
Kissed golden hair and eyes, no longer dull,
For love's first touch brought back their sweetest light,
And half-shed tears and smiles, and blushes, too,
Unto her cheeks like the red rose's hue.

He looked on her and found her radiant face
Beautiful beyond all his heart could dream.
She looked on him with sweet and modest grace,
And blushed and looked once more. The love supreme
That years of joyous misery, time, nor place,
Could change, awoke with its immortal gleam,
And stirred each young heart to its inmost nook—
And lightened in each eye and smile and look.

Cuhullin's father and the sire of Blanid are foes, and so, when the young hero appears at the spring festival, or flower-feast, he is marked for destruction by the fierce King of the Manx. He not only escapes into the forest, but carries off Barana (the angry one?), a battle-steed belonging to the king, which no one else could subdue. The description of the flower-feast introduces various heathen ceremonies, such as the lighting of the Beltane fires and springing through the flames,—old heathen superstitions that have lingered to this day in various out-of-the-way corners of Great Britain. Yet it must be said that there is too much of this. Entranced with the roll of his stanzas, Dr. Joyce has not sufficiently remembered his readers. In stories of this kind they want to get on, and can hardly look upon the verse itself as of sufficient beauty and value to warrant lingering by the way.

Cuhullin has to leave Man without Blanid, but a host of disappointed suitors join him, sail back to the island and besiege the town of the king. The description befits a city of India or of fairyland. In the original legend there is a magic wheel which prevents an entrance after the gates have been battered down. Curoi, a king whose magic had told him of Cuhullin's expedition, and who had joined it in disguise, promises to stop the wheel if he has choice of the finest jewel among the booty. It is accorded him. With magic spear he stops and destroys the wheel, the Manx castle (not a town) is sacked, and he claims, as being the fairest jewel, Blanid! In the legend Cuhullin shows fight at once; here he allows the nameless knight to sail away. This is for the purpose, of introducing an episode called "The Hunting of the Wolf of Bierna," one of those slightly mythological hunts of which there are many accounts among the exploits of the old Fenian and other Irish heroes. It has nothing to do with the story. Cuhullin at last comes upon Curoi, and they fight in presence of Blanid. Cuhullin is wounded, bound, and has his long hair shorn by the victor. His friend finds him left to die in the forest, and the two lurk in exile until his hair is grown again. The following year Cuhullin approaches Curoi's castle in the absence of the latter, meets Blanid, and by advice of Blanid's foster-

* Blanid. By Robert D. Joyce, Author of "Deirdré."
Boston: Roberts Brothers.

mother (a personage who in the Irish legend is always ready to do more for a foster-child than its own parents would), the plot to catch Curoi unguarded is planned. The original speaks of no foster-mother, and does not extenuate the murder in anyway, nor can the devices of Dr. Joyce relieve it of its natural baseness. Then comes Curoi's minstrel in disguise to Cuhullin and Blaid. In sight of the whole court of King Connor, he seizes Blaid in his arms and leaps with her over a precipice.

A prophesy relating to Cuhullin's early death lends a factitious interest to him; his fate is momentarily expected in each chapter. But it is never decided, for the story leaves him safe, while the other actors are all dead. So also with the intimation how Ferkertné, the bard and friend of Cuhullin, suddenly reflects that he, too, is smitten with love of Blaid; although he swears he loves her better than the others, nothing further is said about it. Ferkertné disappears from the story and another friend takes his place by Cuhullin's side; another bard revenges on Blaid the base taking off of her husband.

It may be objected that the difficulty of transporting the plot of a tragedy of a ferocious age into one of imaginary splendor and cultivation is inherent in the situation, and should not be put to the debit of this poet. It is, indeed, excusable enough, if the poetry, as poetry, is of a very high grade. But, reluctant as we are not to find the author of "Deirdré" as happy in that respect as before, the truth is that "Blaid" cannot take high rank as poetry. The lyrics, which are abundantly interspersed, are especially lacking in beauty and point. They are cold and a little forced. They have been manufactured, rather than inspired. Yet the strength of Dr. Joyce shows in another fact, namely, that the latter part of the epic is often finer than the former. In his too long and detailed chapters of the early love of Cuhullin and Blaid, he is not half so fortunate as in his description of the personal encounters between Curoi and Cuhullin:

"I come to win back thy misgotten prize,
Mine own beloved, the bloom-bright Maid of Man!"
"Thou com'st to dye this grass with ruddy dyes
Of thy best blood," cried Curoi, "and to ban
All knighthood with thy word forsworn! Her eyes
Shall see the fight, so let him take who can!
Lo! there she stands, with her fear-whitened face;
Look thy last on her now, and take thy place!"

Meanwhile, as one who on a wreck doth stand,
That the wide wallowing waves toss to and fro,
And sees the saving boat put from the land,
Now high, now in the sea-trough sunken low,
Trembling 'tween fear and hope, each lily hand
Pressed on her heart, as if to hide her woe,
And pale as one who had forsaken life,
Young Blaid stood to watch the coming strife.

* * * * *

Then sprang they to their feet and warily
Looked in each other's eyes with look of hate,
And crossed their jarring swords, and with bent knee
Fought a long time, their burning ire to sate,
Till like a storm-uprooted stately tree
Cuhullin fell, and Curoi stood elate,
Eyeing him as the hunter eyes the boar,
That fighting falls, but yet may rise once more.

On the other hand, the attack upon the stronghold of the Manxmen, although copiously described, is not realized powerfully. We are bewildered by the multitude of defenders, walls and moats, and heroes attacking; as to the magic wheel, so simple in the legend, it is quite impossible to understand its position in Dr. Joyce's version. But it should be said that were this the first book of Dr. Joyce, the verdict would probably be more lenient. "Deirdré" made one expect more of "Blaid." It is only relatively that it should be criticised. To the public it may prove equally agreeable. It is not every ear that is hurt by the halting of a rhythm like that of the second line of the second stanza given above, or that of the first line on page 228:

"I was not born yesterday. I know
The wiles of courts," etc.

nor the many lines that will not run quite smoothly for less obvious reasons. It would make a much stronger impression could it be cut down one half, and thoroughly weeded of its small but very important blemishes.

Baird's "Rise of the Huguenots."*

THERE is in the Astor Library a book in French, without the name of author, publisher or place, called "*L'Etat de L'Eglise. Avec le discours des Temps Depuis les Apostres sous Néron jusques à présent sous Charles V.*" Its title-page is ornamented by three impromptu mottoes, jotted down in a monkish handwriting. Across the face is written *Hic niger est, hunc tu pia turba caveto*, "Beware of him, ye godly crowd, he is black!" On either side of the title-mark the same hand has inscribed, *Sub ovina pelle latro lupus*, "Under the sheep's skin the robber wolf." Finally, at the bottom of the page, where it was usual to place the formal permission to print, has been added *Immodesta licentia*, "By excessive license." The date of the book is 1556. A spark from the hatreds that burned throughout Christendom more than three hundred years ago has come down to the present day in that singular form. It is far more impressive than the printed diatribes hurled at each other by Catholics and Reformers. For some reason or other, the ungovernable dislike experienced by the utterly unknown, forgotten reader of that treatise for the sentiments expressed in the anonymous book, brings up with unusual vividness the condition of affairs in France during the sixteenth century.

Professor Baird has undertaken the survey of an epoch that is anything but lacking in historians. As far back as 1737, we have the Rev. Stephen Abel Laval defending, in a history of three volumes, the Protestants of France against the falsifications of the Jesuit Daniel in his history of France. The

* History of the Rise of the Huguenots of France. By Henry M. Baird, Professor in the University of the City of New York. Two volumes. New York: Charles Scribner's Sons.

present century has seen a number of histories, in English, French, and German, which relate wholly or in part to the epoch under review. It is only the rise of the Protestants which this writer undertakes to investigate. Their fall will probably be the object of a second work. These two volumes cover the years between 1512 and 1572,—the ever infamous year of the massacre of St. Bartholomew,—treating only generally and by way of introduction the affairs of the preceding century which had a bearing on those of the sixteenth. Professor Baird proceeds at a leisurely pace, never hesitating to stop to investigate the reasons for political actions, or to weigh the characters of the participants in a careful balance. The sentiments of Catharine de' Medici toward Protestantism are strictly reviewed. Like some earlier historians, his estimate is that Catharine was purely a politician, and that love of Catholicism had very little to do with her attitude. In 1561 she wrote to the Pope to propose, not merely conferences to be held between Protestants and Catholics, but that images, "forbidden by God and disapproved of by the Fathers," ought at once to be banished from public worship, baptism stripped of its exorcisms, communion in the form of bread and wine restored, the vernacular tongue employed in the services of the church, and private masses discounted. On Corpus Christi day of the same year, in conversation with the young king, her son, she recommended to him that, while duly reverencing the sacrament, he should not entertain so gross a belief as that the bread which was carried around in the procession was the very body of Christ which hung from the cross. Charles replied that he had received the same warning from others, but coupled with the injunction that he should say nothing about it to any one! "Yet," responded Catharine, smiling, "you must take care not to forsake your ancestral religion, lest your kingdom may be thrown into confusion, and you yourself driven into banishment." To which Charles aptly replied: "The Queen of England has changed the religion of her kingdom, but no one gives her any trouble." These, and similar historical proofs, not only exhibit the extent to which Protestant ideas had penetrated the highest classes in France, and those the least liable to their influence, but also removes from the persecutors of the Protestants, and especially from the authors of the massacre, the extenuating circumstance of bigotry. It is one thing to be so firmly convinced of the righteousness of a cause that murder receives the sanction of a perverted conscience, but quite another matter when there is no fixed belief, no hot blood, no blinding bigotry in the case. History shows that not only was there no conspiracy against the crown hatching on the part of Coligny and the Protestants on the eve of St. Bartholomew's Day, but that the murderous king, his treacherous mother, and the Guises, were not really carried away by the vindictiveness of religious passions. Time instead of lessening their shame only adds horror.

Professor Baird has written an able history which will take its place among the treatises on French Protestantism on its own merits as a piece of literary work.

But there is also another reason for its appearance now. In spite of the number and of similar books, whether originally issued in English or translated from the French and German, a fresh review of the epoch has become necessary owing to the publication of new materials for history during the last fifty years. Especially is the "Collection de Documents Inédits sur l'Histoire de France," still in course of publication by the Ministry of Public Instruction, rich with contemporary correspondence and memoirs. It includes even the more important portfolios of leading statesmen. The reports made to the Doge and Senate of Venice by the ambassadors of the republic and the narratives of the envoys of Spain are now open to inspection. The English ambassadors Smith, Throckmorton, Walsingham and others furnish additional matter of exceeding interest. Referring to the epoch immediately following the one under treatment,—the epoch of the settlement of North America, when thousands of French families sought on this continent the freedom of worship that Europe would not allow,—Professor Baird informs his readers that, before very long, his brother, Charles W. Baird, will publish the history of the Huguenot Emigration to the American Colonies in the seventeenth and eighteenth centuries. If it is as well written, sober, and interesting a history as this, the two will form a highly creditable portion of the already handsome contributions by Americans to historical research.

Leland's "Life of Lincoln."*

MR. CHARLES GODFREY LELAND has written for the new series of biographies published by Geo. P. Putnam's Sons under the title of "The New Plutarch," a life of Lincoln which is, in many respects, an admirable work. The author has shown good judgment in selecting such facts and incidents as best illustrate the career and character of his illustrious subject; and where he has used the materials gathered by those who have preceded him in this field, he has done so with skill and with due credit. The study of Lincoln's character will always be a fascinating and profitable pursuit. Born in obscurity, beginning his battle of life on the rude borderland of the republic, it was his fortune to occupy the chief magistracy during a stormy period of American history, when, if ever, a man with an arbitrary or tyrannical disposition might have successfully played the despot. To his lasting honor, it must be said that no President of the Republic ever administered his great office with such absolute fidelity to the will and interests of the people. Practically, as well as theoretically, he was the greatest republican that the world has seen. The principles that underlie our form of government find in his life and services their best exemplification. Better than volumes of essays on popular government, better than the disquisitions of all the philosophers, the official

* Abraham Lincoln and the Abolition of Slavery in the United States. By Charles Godfrey Leland, author of "Hans Breitmann's Ballads," "The Egyptian Sketch Book," etc., etc. New York: G. P. Putnam's Sons.

career of Lincoln, his speeches and his more familiar utterances, show how firm are the foundations of a government by the people and for the people. To apprehend the salient features of such a life, is to catch the informing spirit of the republic. This Mr. Leland has done, and in doing it he has succeeded in giving his little work the vivacity and piquancy of a personal narrative, and the color of contemporaneous history. We see here not only Lincoln the president, but Lincoln the man and citizen. He is not yet a cold abstraction to any who have lived long enough to have been fascinated observers of the great drama which closed with the tragedy of his death. Possibly, many generations must pass before the character of Lincoln becomes, invested with that awful majesty in which great historic personages are finally wrapped; and Mr. Leland has not sought to present his subject in any light but that which belongs to current history.

The work would have been more acceptable to the general reader, perhaps, if it had exhibited less of the author's personality. Whatever else the biography may or may not be, it is not Plutarchian. The writer's passions and prejudices appear too frequently for historical purposes. For instance, it is hardly fair to speak of Stephen A. Douglas as "the political Mephistopheles who had made all the mischief." And one feels something like a shock when he comes upon a phrase which characterizes John C. Fremont as "a plausible political pretender." Governor Hicks, of Maryland, was undoubtedly an obstructionist in the early days of the civil war; but his later repentance and his subsequent services ought to have absolved him from the punishment of being sent down to posterity in a "New Plutarch" as "this Governor Hicks." Frequent blemishes like these make us regret that the author has not lived rapidly enough for the passions of the war to have been cooled in him; he is not yet calm. Nor is his occasional recurrence to his own services and his contributions to the history of the times altogether in good taste. Mr. Leland's verses are undoubtedly admirable, and they were applauded when they first appeared, in 1862; but it would have been more graceful for him if he had waited for somebody else to reproduce them later.

It is unfortunate, also, that the work has been sent out to the public without careful revision, the proof-reading being especially imperfect. It detracts from the value of the book to be reminded on every page of the short-comings of the printer. Moreover, the author is very inexact in his use of proper names. Certainly, so eminent a man as Stephen A. Douglas deserves his full name; but Mr. Leland introduces him as "Stephen Douglas," and thereafter always refers to him as "Judge Douglas." In like manner, John G. Nicolay is bereft of the initial of his second name; and, with ludicrous baldness, John C. Breckenridge and a host of others are handed down to posterity shorn of a portion of their baptismal names. Mr. Lincoln's partner in the practice of the law figures variously in the book as "W. J. Herndon," "J. R. Herndon," and "W. H. Herndon." For carelessness like this there is no

excuse. However, a careful revision of the work, with a few excisions, will make it an attractive contribution to American biography.

Jules Verne's "Exploration of the World."

JULES VERNE has undertaken, at last,* a serious work. Associating with him M. Gabriel Marcel, a most competent historiographer, he has begun the compilation of the narratives of the travels and explorations of the most famous of ancient and modern pioneers in the world's highways of commerce. Necessarily, this task involves a thorough condensation of the records of history. In this respect, the volumes of M. Verne will have a certain quality of dryness which is inseparable from a condensed narration. It is impossible to preserve in such a work the characteristics of the original author, and there is but a small opportunity for the editor (for this is what the compiler must become) to impart to the page any of the graces of style with which he would adorn his own work. But it must be admitted that M. Verne has succeeded admirably in giving an easy flow to the narrative before us. Heretofore he has dealt in fiction of the most extravagant and exuberant sort, and his readers have sometimes been at a loss to determine the boundary line which separates fact from fancy. No writer of modern times has been so indefatigable in collecting from multitudinous researches of others curious and entertaining information with which to decorate and enrich tales of adventure. But in the present undertaking, M. Verne confines himself strictly to the line of historical accuracy.

The volume under review contains the first and second parts of the whole work, which will be comprised in three parts. Naturally, it begins with a sketch of the explorations of the few travelers of the period before the Christian era, and these are so few that one short chapter suffices for the mention of them; another chapter disposes of Pausanias and the explorers who flourished between the beginning of the first century after Christ and the end of the ninth century; while a third chapter records the services to science and knowledge of Benjamin Tudela, Carpini, and Rubruquis. The renowned Venetian, Marco Polo, is the first of the explorers to whose travels it is found needful to accord any considerable space. The section occupied by the wonderful narrative of the Venetian is subdivided into four parts, the whole comprising nearly fifty pages. Next comes Bethencourt, who fills the brief interregnum between the time of Marco Polo and that of Columbus. To the discoverer of the New World is allotted a narration which covers five subsections of the seventh chapter. The exploits of Vasco de Gama, Covilham, Cabral, and the conquest of India and the spice countries are briefly told in the section which closes the first part of this volume.

* The Exploration of the World, by Jules Verne. Famous Travels and Travelers. Translated by Dora Leigh. With illustrations by L. Benett and P. Philippoteaux, and fac-similes of ancient drawings. New York: Charles Scribner's Sons, pp. 432.

The second part opens with the era which began with the exploration and conquest of Mexico, Chili, Peru, and the regions lying immediately south of the country of the Caribs. To all this vast domain the historian gives the somewhat nondescript title of "Central America." This name, to modern readers, has a much narrower meaning than it had to the early geographers, who sometimes spread over boundless spaces an appellation which nowadays describes a single small state. The remainder of the volume is taken up with a very entertaining and graphic narrative of the voyages of Magellan, the Cabots, Cortereal, Drake, Cavendish, Raleigh, the Dutch navigators of the seventeenth century, Dampier, and the first explorers of the Continent of North America; here, also, the ventures of Eric the Red, and other Northmen, are duly celebrated, the story of their deeds being drawn from Professor Rafn's "Antiquitates Americanæ" and M. Gravier's compilations. But where the editor or his translator found any mention of "the Gulf of Boston," on the coast of New England, is a puzzle.

From this sketch of the new enterprise of M. Verne, it will be seen that his work promises to be one of great and permanent value, while enough of the romance and unveracity of the original tales of the early voyagers is retained for all purposes of *vraisemblance*. Their diffuseness is replaced by a succinctness of narration which leaves nothing to be desired. The book is a vivid record of all that we need to know of the spirit which animated and the discoveries which rewarded the early explorers of the world. Later volumes will bring that record down to the days of Sir John Franklin, Beechey, Kane, Livingston, and Stanley. And thus in the three sections will be comprised the story of the discovery of the ancient world and the exploration of modern times. The work is illustrated with numerous wood-cuts, the most valuable of which are reproduced from ancient drawings and engravings. It is also enriched with many curious and rare maps and plans copied from ancient works, inaccessible to most scholars. To young people, whose imaginations are easily inflamed by tales of adventure, this book will be a mine of delightful entertainment, and the genius of the author-editor has imparted to its pages a certain vivacity which cannot fail to hold the attention which is once attracted to the book.

Yriarte's "Venice." *

THIS very handsome volume is a worthy addition to the list of gift-books published from year to year through the last decade, which have succeeded in displacing the gilded fripperies of an earlier time by offering to the public well-written accounts of celebrated places, books of discovery, even scientific treatises of a popular character, all made doubly, trebly valuable by varied, rare, and beautifully executed illustrations. It is an addition to the class of works of permanent worth and interest, including

* Venice: Its History, Art, Industries, and Modern Life. By Charles Yriarte, with numerous illustrations. New York: Scribner & Welford.

Wey's "Rome," Davillier's "Spain," Schliemann's "Mycenæ," Di Cesnola's "Cyprus," and Reclus's "The Earth." Here in one stately volume is a bright panorama of the most beautiful, the most poetic of cities, and as we turn the pictured pages, a lively, well-informed companion pours out a sparkling stream of anecdote and story, much of it the fruit of his own industrious searching, concerning the history of the place, her art, her industries—of glass and mosaics, lace and printing, and ending with an account of the Venice of to-day. Every part of the book is interesting; nor do we know of any one book in the English language which supplies so much valuable material on this subject. Mr. Ruskin's "Stones of Venice," is of course out of the comparison, for that brilliant but misleading book belongs to the region of poetry, of rhapsody rather, and shows us Venice too much by the light of Mr. Ruskin's vivacious prejudices to be of real value. This work of Yriarte's, on the other hand, is not written to support any theories, but with the honest purpose to tell us all and show us all about Venice that can be told and shown in the space allowed. The illustrations, borrowed, for the most part, from sources not easily accessible, add their own charm, though in the case of the more finished pictures the process by which they are reproduced does not always retain the delicacy of the original.

Some Recent Books for Children.

IT is a reason for giving the prettiest pictures imaginable to very little children that older people must be the showmen. Except for that, we should almost grudge to young eyes the riches which books for babies sometimes contain. Here is Kate Greenaway's "Under the Window,"* a book of simple rhymes and bewitching pictures. Nothing could be more quaint or refined than the light, dancing, demure, and coquettish figures that follow one another through these pages. The very grace of an unconscious childhood is in it, and the sweetness and fun must be even more grateful to the parent than to the child. The rhymes are unpretending, but are often touched with a pretty humor, and the best of it is that there is no affectation, and no straining after effect. The bugaboo picture on page 63 is the only blemish.

For children a little older, but still to be read to, there are new issues of the popular "Baby Days," † edited by Mrs. Dodge from the pages of ST. NICHOLAS, and of Mrs. White's "Little Folk Songs." ‡ The charm of these books lies in their motherliness, their sympathy with active childhood, and their refined taste and happy spirit.

* Under the Window: Pictures and Rhymes for Children, by Kate Greenaway. Engraved and Printed by Edmund Evans. London: George Routledge & Sons.

† Baby Days. A Selection of Songs, Stories and Pictures for Very Little Folks. 300 illustrations. New edition with music. New York: Scribner & Co.

‡ Little Folk Songs. By Alexina B. White, with illustrations by Addie Ledyard and others. Boston: Estes & Lauriat.

In Mr. Scudder's new volume, "The Bodleys Afoot*" we find many old favorites in prose and verse, ballads and tales which can never grow old, and which should always be kept where the young folks can get at them. These are introduced very deftly by the author, who brings forward things new and old with a spontaneity and naturalness which is quite wonderful in its way. After a home episode, in which a delightful sea-faring story-teller is introduced, the Bodleys start off on a tramp from Roxbury to New York by the old Hartford post-road. As their route is through localities rich in the reminiscences of colonial times, scraps of early American history, mingled with a few modern instances and wayside adventures, happily beguile the journey's tedium. The Bodleys, we believe, never had a "story" underlying their various adventures; but the simple narrative of their lives has always been full of bits of fable, history, and nature which have combined to present a mosaic of charming color and design. The present volume will sustain the young readers' unflagging interest from the Japanese designs of its front cover to the end of the grandfather's autobiography.

The children who read "Eyebright,"† will probably do so without much help from their elders, and they will be likely to follow with sympathy the experience of the child who courageously led so apparently dreary a life. It is not the story of a happy childhood, as we ordinarily use the term; it is the story of a child whose faithfulness and imagination made her unfortunate surroundings powerless to hurt her. There is a good deal of fun in the book, and, in one or two instances, a little mistaken satire.

For children of the same age, or those a little older, may be named Miss Alcott's latest collection,‡ headed by "Jimmy's Cruise in the *Pinafore*," and including a baker's dozen of short stories. They are all characterized by Miss Alcott's good nature, and if life seen through them looks rosy, there is no harmful distortion. Nevertheless, we think children old enough to read these stories would not get more than a passing entertainment out of them, with one or two hints of helpfulness. But there are times when pleasure, even more than instruction, is necessary for a child, and the interest of Miss Alcott's books does not seem to be impaired, even by her noticeable carelessness of style.

The "one more" for whom room is made in Mrs. Higginson's little book,§ is a prankish boy, bereft of his mother, who is taken into a family of children by their over-burdened parents. The theme is a simple one, which will appeal to all healthy children, and it is worked out simply and effectively. The rambling story of the crowded family life is not very eventful, but it is better—it

is truthful. There are side glimpses of the older people which are excellent for their lightness of touch, and the children are well marked. What we especially like about the book is its faithfulness to the best things in family life, its gentle arguing of the moral by giving a plain and natural record. It is not literary, but in its whole manner it recognizes the fact, which many writers for children forget, that books for children are not literature: now and then literary skill may show itself, but the most we ask of the great bulk of reading matter for children is that it should reflect without effort the best life that is open to their eyes and mind.

"Nimpo's Troubles"¶ is the story of the scrapes into which a little girl and her brother fell when left to themselves in a western village, their parents having gone away for the mother's rest. The children, with a still younger child, Nimpo being twelve years old, are left in the general care of a neighbor who takes them as boarders. To board is the height of Nimpo's ambition in ladyhood, and the reader need not be told that her experience leads her to welcome her mother home with enthusiasm. Mrs. Miller intimates in the first sentence that the story is from life. It probably is true in many particulars to life; if it is to be taken as it stands it is an extraordinary commentary on parental negligence and youthful independence. The scrapes, however, involve nothing of baseness or meanness.

The holidays also bring an attractive book for boys in the shape of a fresh presentation of the chronicles of Sir John Froissart.† Mr. Sidney Lanier deserves high praise for his admirable fulfillment of an admirable task. He has taken the bulky chronicles and reduced them to a comely volume of four hundred pages or so, by omitting the portions which were digressions from a somewhat straightforward narrative, and by a skillful dropping all along the way of superfluous paragraphs and clauses. The knight's style has its charm; but it has it in spite of its half-legal verbosity, not because of it; and we have no hesitation in saying that Mr. Lanier has improved upon Johnes' version, and he has done this, not by changing the words, which are rarely defective, but by omitting pleonastic expressions and redundancies. Yet the best praise belongs to Mr. Lanier for doing the work itself; for introducing to boys so chivalrous a book. How many a pulse will beat quicker with manly enthusiasm upon reading these pages! What a splendid pageant passes before the eye and kindles the imagination! Mr. Kappes has caught well the genius of the book in his pictures, and has given careful studies, which are not coldly correct, but spirited and genuine.

The last book on our list is a comprehensive one, which may well be given to all the children who do, or do not, read those which we have named.

* The Bodleys Afoot; by the author of "The Bodleys on Wheels," "The Bodleys Telling Stories," "Dream Children," etc., with illustrations. Boston: Houghton, Osgood & Company.

† Eyebright. A Story by Susan Coolidge. With illustrations. Boston: Roberts Brothers.

‡ Aunt Jo's Scrap-Bag. Jimmy's Cruise in the "Pinafore," etc. By Louisa M. Alcott. Boston: Roberts Brothers.

§ Room for One More. By Mary Thacher Higginson. Boston: Lee & Shepard.

¶ Nimpo's Troubles. By Olive Thorne Miller. Illustrated by Mary Hallcock Foote and Sol Eytinge. New York: E. P. Dutton & Co.

† The Boys' Froissart; being Sir John Froissart's Chronicles of Adventure, Battle, and Custom in England, France, Spain, etc. Edited for boys, with an Introduction by Sidney Lanier. Illustrated by Alfred Kappes. New York: Charles Scribner's Sons.

"The Young Folks' Cyclopædia of Common Things" * is a household book, well conceived and sensibly executed. It is a great cyclopædia reduced in size, limited to articles on subjects of interest to the young, and written in a plain, untechnical manner for such readers. It is not especially concerned with the pursuits of boys and girls. It has articles, to be sure, on the "kite" and "marbles," but none on the "bicycle" or "postage-stamp" or "album"

* The Young Folks' Cyclopædia of Common Things. By John D. Champlin, Jr., late associate-editor of the American Cyclopædia. With numerous illustrations. New York: Henry Holt & Co.

or "crochet." But these are the last subjects, probably, for which children would expect to consult a cyclopædia. Such things, like Dogberry's reading and writing, "come by nature." The book will prove of use in schools which cannot afford many books of reference, and if it teaches children to hunt for the satisfaction of their questions, it will serve an excellent purpose. With this view, we wish the editor could have given suggestions sometimes at the end of articles, by which the inquirer could have been sent to fuller special authorities. To make a child an investigator is to give him the clue to genuine self-education.

THE WORLD'S WORK.

New Stage for Theaters.

AMONG the fine arts none has passed through more important changes within the past few years than stage-art. Dramatic representation now concerns itself with every phase of life, and aims to produce in the stage pictures as true to nature as possible. Instead of painted curtains, called "flats," and side-scenes or "wings," we now have elaborately built-up scenes representing both interior and exterior views of every shape and proportion. This has compelled the use of "set-scenes," a built-up scenery supported by ropes and braces in place of grooves, as in the older theaters. This implies a great deal of labor in changing the scenes between the acts, and this in turn implies a loss of time, keeping the audience waiting and suspending the interest of the story. To obviate all this and allow of ample time for setting the scenes, a new stage, now erecting in one of the theaters in this city, employs a large elevator having three floors, two of which are stages each with entirely separate sets of scenery. In erecting the double stage, a space about 8.54 meters (28 feet) by 12.15 meters (40 feet) and 19.82 meters (65 feet) high was enclosed and roofed over. In the wall, next the audience room or hall, is cut the proscenium arch, 6.30 meters (20 feet) high, and 7.32 meters (24 feet) wide, the bottom of the opening being 7.63 meters (25 feet) above the floor of the cellar, or bottom of the stage space, and the top about as far below the roof of the stage. In the stage space are placed four floors, the lowest resting on the bottom of the cellar, the second at the level of the proscenium, opening and forming a part of the stage extending out into the hall, and making the front of the stage proper. The third floor is just above the proscenium arch, while the fourth floor is higher still, next the roof. In each of the three upper floors is an opening, 6.71 meters by 9.16 meters (22 by 31 feet), extending from the cellar to the roof, and forming the wall of the elevator. The elevator itself is hung on steel ropes, passing over sheaves supported near the roof on massive timber-work, and carries three floors, two of these being stages placed one over the other, and the third taking the place of the

rigging loft or "gridiron" in ordinary theaters. In operation it is designed to use the elevator in this manner. Suppose the first act of the play requires a set scene. The elevator is lowered till the first floor rests at the bottom of the cellar, the second floor making the actual stage seen by the audience. On this stage the play proceeds, while below, in the cellar, the carpenters are preparing the scenery for the next act. At the end of the first act the curtain is lowered, and the elevator is raised, carrying the stage just used, with all its set scenery, furniture, and properties, up to the third floor, and bringing the stage below, with all its scenes and properties in place, up to the second floor, or level with the proscenium. This movement is estimated to require not more than ninety seconds, and the curtain will be at once raised and the play will proceed without detention. During the second act the carpenters on the third floor remove the scenery and furniture, and set the scenes for the third act. At the end of the second act the curtain comes down and the elevator is lowered, the stage just used going into the cellar, and the stage above coming down into place all ready for use, the operation not requiring more than a minute or a minute and a half. In some instances, when the action of the story proceeds from the top of a bridge or building to the stream or road below, or *vice versa*, the bridge or interior together with all the scenes, properties, and actors, is bodily raised or lowered in full sight of the audience,—one act being joined to the next without a gap, very much as scenes are changed in the older theaters, except that in this case the furniture, actors, and the stage itself are changed at the same time. Entire scenes are often raised from the cellar or lowered from the lofts in many theaters, but this is the first attempt to make a movable stage, and the practical working of the apparatus will be watched with the greatest interest. The apparatus is patented.

Influence of Time on Stress.

THE influence of time on mechanical action has been fully demonstrated. A quick blow is more effective than a slow one of the same weight. Any object driven quickly through the water requires

more force to push the water aside than the same object when moved slowly, and there is a limit to the speed when the object, whatever its shape, cannot be moved at all. The particles of water not being given time to move away before the object, it must stop or be destroyed. It has been also shown that metals assume under stress the characteristics of unstable fluids,—iron, under severe pressure, flowing like water, provided time is given for the movement. In this connection it has been lately shown that time has an important bearing on the strength of wires under strains. A series of wires of the same make, gauge, and length were hung up, and from each was suspended a given weight that could be borne without strain or alteration. More weights were then added at short and long intervals till the wires broke. The elongation of the wires under the increasing strains and the breaking points were carefully noted, and a comparison of the results shows that time is an element that must be considered in testing metals under stress. Comparing the breaking weights of the wires broken under repeated additions of the load, or strain, at intervals of a few moments, with like addition at intervals of twenty-four hours, it was found that there was a difference of from two to ten per cent., with an average of five per cent., in favor of the wire treated slowly. That is, where the strains, though equal, are increased very slowly, when time is an element in the test, the wire will carry a heavier load, will bear a higher strain by about five per cent. The stretching or elongation of the wire before breaking exhibited a more remarkable difference, the elongation being more than three times greater in the wires strained quickly than in those strained slowly. These facts promise to throw much light on strains in iron beams, rods, and structures.

Book-Sewing Machine.

A NEW machine for sewing the leaves of books in place of binding them in the ordinary sense has been brought out, that presents some features of interest. The leaves are cut at the back in the usual way, and are fed to the machine by hanging each folded sheet on an arm and fastening it down by a catch. The arm then moves to the machine and holds the sheet before the sewing needles, when spring clamps grasp it and release the arm that drops down out of the way ready for the next sheet. Four curved needles, threaded at the point with any common thread, pass through the cuts in the sheets, turn upward through the next cut, and form a loop with the thread. At the same time, four larger horizontal needles, carrying heavy cords, pass through the loop knotting the thread. All the needles then draw back tightening the stitch. The next sheet is sewn in the same manner, except that four other curved needles come into play sewing in the opposite direction, so that each alternate sheet is sewn to the left or right, and binding the book by an "off and on" sewing. The machine, under careful examination, appears to work with precision and uniformity. With fair attendance the

speed is reported at 30,000 signatures in ten hours. The machine seems likely to be of great value to the book-binding interest. No knotting or tying is required at the end, as each sheet is sewed to the next and finished completely.

New Faradic Machine.

OF the great number of dynamo-electric machines, now called Faradic machines, brought out within the last two years, the latest appears to be the cheapest and most simple, and is reported to be the most effective. It consists of two field magnets standing upright, the cores being of wrought iron, 15.3 c.m. (6 in.) in diameter, and 91.5 c.m. (36 in.) high, standing upright on cast-iron blocks 27.5 c.m. (10¾ in.) high and 23 c.m. wide, and joined at the top by a wrought-iron yoke 15.3 c.m. high and 18 c.m. wide. The cores and yoke are fastened together by massive screws, the whole being mounted on a heavy brass plate that also serves for a support for the armature and its bearings. The cores of the magnet are wound with three layers of cotton covered copper wire (size No. 10), the ends being connected by binding posts at the base of the machine. The armature revolves horizontally in a cylindrical space between the poles of the magnet, and consists of a wooden core, supported by a shaft 4 c.m. in diameter. At the ends of the wooden core are soft-iron disks, and between these are wound round the core several layers of soft-iron wire. Outside the disks are others of vulcanized rubber, notched at the edges to receive the forty-one coils of insulated wire, wound lengthwise on the cylinder, and connected by copper bars with the commutator cylinder at the end of the shaft. The machine is designed to be driven at a speed of 500 revolutions a minute, and is reported to have an internal resistance of only ½ an ohm, and to give 90 per cent. of the power applied as effective current. For the reconversion of electricity into power Faradic machines of similar construction, but laid down horizontally, are being made for use as domestic motors. These motors are designed to be used where electricity is distributed by wire from a central source of power.

Calculating Attachments for Weighing-Scales.

THIS very simple apparatus is designed for the convenience of retail dealers in estimating the price of any materials sold in irregular quantities by weight. In consists of a hollow cylinder of some light material provided with supports to keep it in a horizontal position, and having a narrow slit or opening extending the whole length on the upper side. Inside the cylinder is a smaller cylinder or drum, designed to be covered with paper on which may be arranged in longitudinal rows the prices of various qualities (by weight) of the goods,—tea, sugar, coal, flour, etc.,—that are to be sold, each article having its own column and the prices increasing in a fixed ratio from left to right. This drum when covered with the figures is suspended, by bearings

at the ends, inside the cylinder, one row of figures then being visible through the opening at the top. To display other rows of figures the drum may be turned by means of a handle at the end, any set of figures being brought into sight that may be desired. The apparatus is then placed under the beam of a weighing-scale and from the weight on the scale is hung a pointer or marker that points to the proper price below for the weight recorded by the scale. The device has the advantage of indicating both the weight of the things measured and the price for that quantity at the same time, showing the purchaser the price and saving the dealer the delay of figuring out the sum.

Fire-Screen for Forges.

THE intense heat to which men working in forges and furnaces are exposed is often more exhausting than their labor, and various kinds of guards and fire-screens have been tried with more or less effect. A new form of screen, or apron, recently brought out, employs two large sheets of thin metal riveted together at the edges and leaving a narrow space between them. To the top is fastened a hose that brings cold water to the apron, completely filling it, while a second hose conveys away the water from the bottom. In operation the apron is kept constantly filled with running water that absorbs all the heat, making an effective guard against the fire and materially cooling the air of the place. The apron is hung by chains from an overhead railway, so that it can be moved away when not needed. It is also quite flexible, and may be bent or pushed one side by hand, as the work requires. The water escapes from the apron quite hot, and may be used for boiler feed water or for other purposes about the works.

Palmeline.

THIS is a new coloring matter recently obtained, that appears to possess some peculiar properties. The red alga, *Palmella cruenta*, growing freely near damp walls, when carefully dried in the air, is digested in a small quantity of water in a covered porcelain vessel, when a coloring matter dissolves out in about twenty-four hours, and may then be decanted as a fine rose-red liquid, showing an orange-yellow by reflected light. This coloring matter is reported to bear a singular resemblance to the coloring matter of blood or hæmoglobine, and like it, is insoluble in alcohol, ether, benzine, or bisulphide of carbon, but dissolves readily in water. Like blood, it may be coagulated by heat, acetic acid or alcohol added to its watery solution; it likewise readily undergoes putrefaction at summer heat. Under spectrum analysis it is found closely allied to blood, while, like blood, it also contains iron. The brilliant color of palmeline seems likely to make it valuable as a dye or stain.

Sanitas.

THIS is the name of a new disinfectant. It is made by floating Russian turpentine on water in large earthen jars, kept at about 90° Fahr., and blowing a blast of air through the water. Decomposition follows, giving a precipitate containing, among other materials, protoxide of hydrogen and camphoric acid. The material left floating on the water after the process is complete is mixed with lime to form a dry powder, and both this and the precipitate, singly or mixed together, are found to be useful as disinfectants, the floating matter being considered the most valuable.

BRIC-À-BRAC.

Sweet and Low.

A GENTLEMAN in New York was recently descanting to a friend on the soft notes of a linnnet which he had heard a few days before.

"Why," said he, "it sang so softly at times that you couldn't hear it at all."

"S-h-h-h!" said the other, placing his hand to his ear, "perhaps there is one singing now."

American Books on the Paris Quays.

[The following postscript to Mr. Osborne's "Oddities of Paris" in this number was unavoidably crowded out of that paper]:

A LITERARY man once said: "Whenever I begin to study a subject, my first visit is not to the library in Rue Richelieu, but to the quays. I have never once gone there to collect works on any subject, that I did not see books in those boxes of whose existence I before was ignorant. When I have explored those fields, I often find it is unnecessary to go to Rue Richelieu." At Huet's shop,

in Rue de Savoie, one may find a larger collection of odd numbers of periodicals and newspapers—(this is the place to get those objects whose loss fevers so many hours of the bookworm's life); but in the course of time,—for it does take time,—an attentive frequenter of the quays will see a more varied collection here than at Huet's. The latter has only French journals; on the quays you see not only these, but English, Belgian, Swiss, Italian, and American periodicals. If you want pamphlets, you must go to the quays for them. I instance these examples to confirm the remark just quoted. Everybody familiar with books knows how hard it is to match broken sets, and that it is still harder to find an absent newspaper to complete a file, and hardest of all to collect pamphlets on any subject. None of the book-shops keep pamphlets. Sometimes, in buying private libraries, they obtain some; but, when any number have accumulated, they sell them by weight to the booksellers on the quays, who, by the way, are not looked on as members of the trade.

They are not even styled book-sellers, but second-hand-bookers (*bouquinistes*, from *bouquin*, a second-hand book).

Although the constant and large stream of travelers partially explains it, still it is wonderful what an immense variety of American works are to be found on the quays. I mention American publications particularly, as being more familiar to us. Here let me cite two examples of the keen attention given to trade by these despised brethren of the guild. Every frequenter of these boxes knows that, by merely walking past them, he can discover the questions which engross the public mind of the day. Works on these topics are seen there in profusion. I was nevertheless greatly astonished to see Bayard Taylor's works in these shops on the very day the newspapers announced his arrival here, and again when the intelligence of his death reached Paris. The day General Dix's death was published, several copies of the edition of his speeches dedicated to his wife, and one copy of his message as governor, were offered for sale in these boxes. I was so much astonished I could not help asking the seller for an explanation. One of them answered: "Haven't you seen the morning papers? They announce his death." Another replied: "He is an American statesman who has just died." This intelligent attention is all the more astonishing, for these men are not only very ignorant of bibliography, but are ignorant even of orthography.

I have seen here Edmund Ruffin's essay on "Calcareous Manures," published by J. W. Campbell, Petersburg, Va.; Ik Marvel's "Battle-Summer," the fly-leaf covered with a note to Abbe * * signed Donald G. Mitchell; a collection of acrimonious pamphlets published by the Breckenridges of Kentucky, to air a family quarrel; presentation copies of Bancroft's History, but without autographs, the presentation being made by a small printed card pasted inside; an anonymous life of John C. Calhoun, in pamphlet form, with six manuscript pages pasted inside; these attribute the biography to R. M. T. Hunter, and give a very fair sketch of the latter's life, mentioning some of his peculiarities which are known only to a few people; a life of Amos Lawrence, with two book-marks, one a common-place letter from Daniel Webster, the other quite a private letter from Robert C. Winthrop; a volume containing the Constitution of the United States, the "Federalist," and some political tables, with a long letter from Pierre Soulé; another copy of the same book, with a note from Pierre Soulé on the fly-leaf; a report of the trial of Theodore Parker; an "Atlantic Monthly," having on the title-page "With the compliments of Mrs. Harriet Beecher Stowe"; Vallandigham's speeches; all the directories published in the United States, not excepting one of San Francisco; Professor Beck's translation of a German work on gymnastic training, with ten pages of note-paper containing a very malignant and untrue manuscript biography of the translator; a small volume of poems published anonymously, but with ten pages, also on note-paper, in a woman's hand, giving an amusing

and anything but good-natured sketch of "Edmund Quincy, the author of these poems," and of his family. I know a gentleman who has picked up in these boxes a presentation copy of Motley's History, with a long and interesting letter from the author. The late Rev. Athanase Coquerel, Jr., went to the United States shortly before his death and returned to Paris laden with presentation volumes. All of them were to be seen in these boxes after his death. It is incredible what treasure-trove may be found on the quays after the death of an eminent man. The more valuable books of his library are commonly sold in Salle Silvestre (the great book-auction mart of Paris, and one of the oddest places here); but all the periodicals, pamphlets, and the like, are sold directly to the book-sellers of the quays or are sent to the general auction-room in Rue Drouot, where these book-sellers buy them. After the death of any eminent man the number of presentation copies sold here, all with dedications in the autograph of the author, and sometimes with a long note from him, is incredible. A good many eminent men clear their libraries of "trash" twice a year, or whenever they change lodgings, or whenever their books exceed the capacity of their rooms. This plethora is a common disease of libraries in Paris, for here men live rather in dove-cotes than in houses. In this "trash," which is commonly sold by the pound,—a system adopted by all the book-sellers to clear their shelves,—one always finds valuable material.

Wanted—A Minister.

"MY DEAR —: * * * Oh!—by the way, if you learn of any one with energy, tearful interest in the conversion of souls, attractive in preaching, great-hearted, unselfish, merry, in fact, holy—let me know. Paul was much the kind of man we need. We want a man who knows all about the enemy, has some capacity for working miracles, is ready to be stoned, can teach the women, interest the children, make princes tremble, confound the Jews, convert kings, pick up sticks, earn his own living, go through fire and water for the good of others with no expectation that they will interest themselves in him—and, in general, lead a forlorn hope of despondent followers." * * *

Specimen Bricks from the Dictionary of the Future.

Accordeon: a pair of bellows which have accidentally swallowed a jew's harp. *Auctioneer*: a man of mor-bid temperament. *Eccentricity*: regular irregularities. *Genius*: a lunatic—more or less sane. *Knack*: the art of using genius. *Love*: an archer who never uses a cross beam. *Prudery*: the parody of modesty. *Plagiarism*: the discovery that our ideas have been stolen by our predecessors. *Peace*: War taking a nap. *Part Songs*: (German) a game of follow my *Lieder*. *Quadrille*: a silent protest against the immorality of dancing. *Selfishness*: a preference misplaced. *University*: academies in winter of scholarship, and in summer of sculler-ship.



WEALTHY OLD GENTLEMAN WHO BUYS HIS PICTURES BY PROXY: "Both very fine, ma'am,—one Joseph, the other Arimathea,—forget exactly which is which."

A Lesson in Mythology.

I READ to her, one summer day,
A little mythologic story
About the maid who laughed at love,
And ran a race for love and glory.

I closed the book. She raised her eyes,
And hushed the song she had been humming;
Glancing across the shady lawn,
I saw my wealthy rival coming.

"These ancient tales," I gravely said,
"With meaning wise are often laden
And Atalanta well may stand
As type of many a modern maiden.

"Minus, of course, the classic sandal,
But with no less of nimble grace,
How many dainty slipped feet
Are running now that self-same race!

"And when Hippomenes casts down
His golden apples, is there ever
A chance for love to reach the goal?"
With saucy smile, she answered, "Never!"

I rose to go—she took my hand—
(O Fate! you ne'er that clasp can sever,)
And, "Stay," she said, with sudden blush,
"You *know* that I meant—*hardly* ever."
ELIZA C. HALL.

Personal.

Two friends, who were divided in opinion as to the relative merits of a certain well-known man, were recently discussing his qualities, when one of them said, evidently thinking it a clincher:

"Well, at any rate, he knows what he's talking about!"

"Undoubtedly," replied the other, "he ought to, for he's generally talking about himself."

Political.

THE following conversation was overheard in a New York city street-car during the recent canvass for governor in that state. The car, with a number of others, was stopped by a political procession which was crossing the track. Several of the passengers got out to ascertain the cause of the delay. Finally, an Englishman—a veritable cockney, eye-glass and all—came out to the back platform and accosted a native of the Vaterland, who was standing there.

"Aw—what is the mattaw?"

"De car ish stop," answered the phlegmatic German.

"Ya-a-s. But why is the car stopped?"

"It's one o' Shohn Kelly's processions," was the reply.

"Jawn Kelly?" said the cockney.

"Yah, de politics man."

"Oh ya-a-s, they are electing *some of their pwesidents*, I spwose."

Hereupon the car started, and the Englishman returned to his seat, apparently pondering over the "cuwious customs of the new countwy."

WHEN Mr. Tilden, in 1874, was nominated for governor of New York, Mr. Dorsheimer received the nomination for lieutenant-governor. The ticket thus headed was elected generally by about fifty thousand majority. A little knot of Germans in New York City, who usually voted the Republican ticket, took Mr. Dorsheimer from his name to be a German, and scratched their state ticket in his favor, so that he had a majority of nearly fifty-three thousand. One day, after Mr. Tilden and Mr. Dorsheimer had been inaugurated, they met at a political breakfast at the former's house in Gramercy Park. Mr. Tilden had always felt a little sore at Mr. Dorsheimer's extra majority, and so when in the current of conversation Mr. Dorsheimer jestingly said:

"Well, Governor, you must remember I had three thousand more majority than you."

As quick as a flash Mr. Tilden retorted:

"Yes, you supplied the three thousand and I lent you the fifty."

In November.

OH, mark how through the lattice-work of brown—
November's trees—the lights of gray skies sift!
Nor birds may sing, nor any shadows shift
Below the sunless gables of the town.
Now brooks run tawny, and a purple crown
Of elder-tops the marsh hollows lift,
While haunting twitters from the thickets drift,
And hollow pipes the gale across the down;
And memories like voices fill the gale—
The joy of harvests and the hope of springs,
And songs, though felt, unsung, and griefs that
pale,
And loves that flush, and hopes that lift on wings,
And sunlight on the silent, winter hills,
Thrilling anew the heart that sorrow thrills.

L. FRANK TOOKER.

SCRIBNER'S MONTHLY.

VOL. XIX.

JANUARY, 1880.

No. 3.

THE UNITED STATES LIFE-SAVING SERVICE.



OFF TO A WRECK.

In the principal newspapers of commercial cities there may be seen, under the caption of "Marine Intelligence," or some such title, a column made up of items, set in nonpareil type, like the following, cut from a recent journal:

Bark *Haleyon* (of Bath) Dickinson, from Boston for Perth Amboy, in ballast, went ashore on Long Beach, LI, AM of Sept 4. All hands were taken off by the crew of Life-Saving Station No. 32.

Has the reader any idea of the stirring drama a dry paragraph like this may conceal? Let us endeavor to make it apparent.

No portion of the ten thousand and more miles of the sea and lake coast-line of the United States, extending through every variety of climate and containing every feature of coast danger to the mariner, can exhibit a more terrible record of shipwreck

than the long stretch of sandy beaches lying between Cape Cod and Cape Hatteras. Of this region the New Jersey coast is notoriously the worst. It has been said that if all the skeletons of vessels lying upon or imbedded in the sand between Sandy Hook and Barnegat could be ranged in line, the ghastly array would reach from one point to the other. Here, in 1848, the government placed a few rude huts that formed the nucleus from which the United States Life-Saving Service has been developed. These were intended to afford shelter to distressed mariners and to contain boats and such other life-saving appliances as were then known, volunteers from among the fishermen being relied upon to use them on occasions of shipwreck. And right gallantly, in many instances, did the brave beachmen respond, though their undertakings and

deeds remain mostly unwritten, existing chiefly in the legends of the coast. Congress continued small appropriations from time to time, until Long Island was also provided with huts and a small increase was made to the number on the coast of New Jersey. But from lack of proper direction and want of system the movement languished and subsided. In the meantime, the Royal National Life-boat Institution, a society started in Great Britain under royal patronage nearly forty years prior to our own attempt, had gone on improving its methods and extending its means, and the people of other maritime nations were developing similar humane projects. The hour and the man at length came for our own institution. In 1871, Mr. Sumner I. Kimball, the present able General Superintendent, effected the organization of the service and introduced the existing system.

There are now upon the sea and lake coasts nearly two hundred life-saving stations, the greater number being established at the more dangerous and exposed points. The buildings are plain, yet picturesque,

cannot be launched from a flat beach on account of its great weight and huge size, objections which are unavoidable in securing the valuable qualities that distinguish it.

The main building has, below, a boat-room and a mess-room, or kitchen, each provided with convenient closets and lockers, and, above, two sleeping apartments and a store-room. The boat-room contains the surf-boat, which is used on flat beaches and in shoal waters. It is mounted on a light carriage, which may be drawn by the crew when draught animals are not available, unfortunately too often the case on remote outlying beaches. Within the same room also stands the mortar-cart loaded with the wreck ordnance, lines, and various implements, while properly bestowed throughout the apartment are various articles, most of which will come under our notice in the operations to be described. The kitchen and sleeping-rooms are sparingly provided with appropriate furniture, while the store-room is used for the stowage of the season's provisions, cordage, spare oars, etc. Here the keeper and crew live during

the active season, which varies according to the latitude of the districts into which the coast is divided.

The keeper commands the crew of six surfmen. His position is one of grave responsibility, demanding long experience in his vocation and rare judgment in the execution of his important trusts. The selection

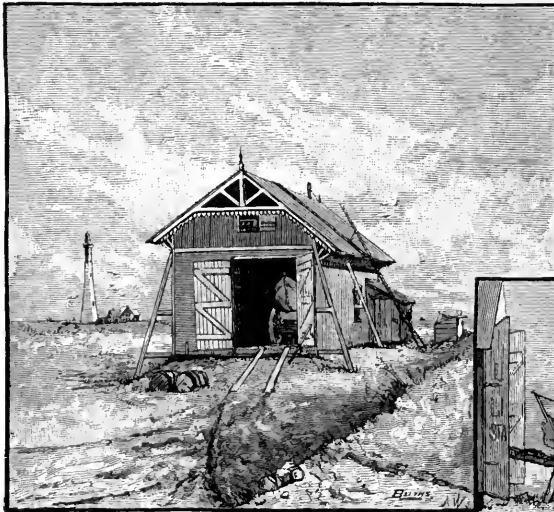

LIFE-SAVING STATION.

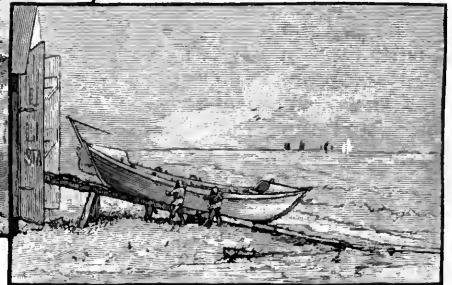

SELF-RIGHTING BOAT ON WAVES.

and similar in general dimensions and arrangement, though varying somewhat in outward design, according to location—those near cities or popular watering-places being in keeping with their surroundings and presenting a more finished appearance than those on desolate beaches. Those located in harbors or at inlets are each provided with an annex containing a self-righting and self-bailing life-boat, which

of his men, upon whose fidelity and skill depend not only his success, but oftentimes his life, as well as the fate of those whom he is expected to succor, is very properly confided solely to him. Both keeper and men are chosen from among the fishermen in the vicinity of the stations, who are most distinguished for their ability as surfmen. Draw-



DRILL AND EXERCISE IN THE SURF-BOAT.

ing their first breath within sound of the surf, they pass through childhood viewing the sea in all its moods. In early youth they make their first essay in the breakers, and from that on to manhood advance from the least important oar through regular gradations, until the most skillful reach the command of the boat. This life gives them familiarity with the portion of the beach upon which they dwell, and its bordering currents, eddies, and bars, and an intimate acquaintance with the habits of the surf. It is an erroneous notion that the experience of the sailor qualifies him for a surf-boatman. The sailor's home is at sea. He gives the land a wide berth, and is never at ease except with a good offing. He is rarely called upon to ply an oar in a small boat, particularly in a high surf, and his vocation gives him little knowledge of the surfman's realm, which is the beach and a portion of the sea extending but little beyond the breakers. The number of mariners who are annually lost in attempting to land from stranded vessels through the surf in their own boats, sorrowfully attests this fact. On the other hand, the most expert surfman may not be, and often is not, a sailor, though generally he has an excellent knowledge of every part of a ship and her apparel, gained in his occupation of stripping wrecks.

The training of the surfmen as life-saving

men is completed by officers of the Revenue Marine, whose own professional training, familiarity with the coast (acquired in their cruises along shore for the prevention of smuggling), and experience in assisting vessels in distress, especially qualify them for the duty.

The life of the station surfmen is rather a monotonous, though not an idle, one. Each day has its portion of drill and exercise in the various methods employed in rendering aid to the shipwrecked, and considerable of the spare time of the men is occupied in keeping the building and apparatus in repair, and in making improvements around the station. At night their duties become severe and often perilous. The interval from sunset to sunrise is divided into three watches. At the beginning of each watch two men set out from the station on patrol duty and follow their beats to the right and left respectively until they meet the patrolmen from the adjacent stations, with whom they exchange certain tokens as proof to the keepers in the morning of the faithful performance of the duty. The relieving watches keep up this scrutiny until sunrise, and, if the weather be foul, throughout the day. The meeting and exchange of tokens is required, of course, only upon continuous beaches, or uninterrupted stretches of coast, where the stations average a distance of from three to five miles apart. At isolated

stations the limits of the patrol are fixed by specific boundaries. This watching of the beach is of cardinal importance, and neglect of the duty is punished by banishment from the service and prohibition of future employment.

The beach guardians are no idle promenaders. A march of four or five miles through the soft sea-sand is a task at any time; what is it in the fury of a winter storm? The prevalent strong winds, which must be encountered in one direction or the other of the beach, drive before them rain, snow, hail, and sleet, or oftener sharp sand, which cuts the face until, smarting with pain, the patrolman turns and walks backward for relief. Such is the force of this natural sand-blast that it soon dulls the glass of the patrol lanterns, and at some of the more exposed stations has made ground-glass of the window-panes. In a snow-storm the ocean beach is the wildest of pathless deserts, and even by daylight, shut out from prominent landmarks, the foam of the breaking surf alone serves to guide the panting patrolman on his way. Leaving it, he would wander helplessly among the sand-dunes that crown the beach. When the darkness of night is added, and his lantern, if not extinguished by the gale, but feebly lights his path through the slush of snow and sand, he strays and stumbles into pitfalls and quick-sands, to recover his way and accomplish his journey only through his life-long acquaintance with every foot of the ground. Sometimes, failing in this, benumbed with cold and bewil-

dered by his mishaps, he is found by his comrades in the snow insensible, or perhaps dead. Then there come, fortunately not often, the blast of the hurricane and the inundation of the tidal wave, pregnant with terrors indescribable. These are the tornadoes which, inland, uproot trees, unroof and prostrate buildings, destroy flocks and herds, and create general havoc. On the beach the stations are sometimes torn from their strong foundation-posts and overset and borne away by the flood, the inmates escaping as best they can. The patrolman cannot stand up against the fury. Again and again he is overthrown as he struggles to reach the top of a sand-hill, his only refuge from the waters which rush upon the land and sweep through the depressions between the hillocks, separating them into islets. In the memorable tempest of October 22 and 23, 1878, the patrolmen suffered severely, and several were in extreme peril. In one instance, a patrolman not returning in the morning, and his fellows not being able to discover him with their glasses from the look-out of the station, a boat expedition was sent in search of him among the still flooded sand-hills, upon one of which, nearly covered with water, he was at length found, barely alive.

When a vessel is driven ashore in a storm, the patrolman, being the first to discover her, takes the initiative steps in the operations for the rescue. He carries at night, besides his lantern, a signal, which ignited by percussion emits a red flame. He is quick to

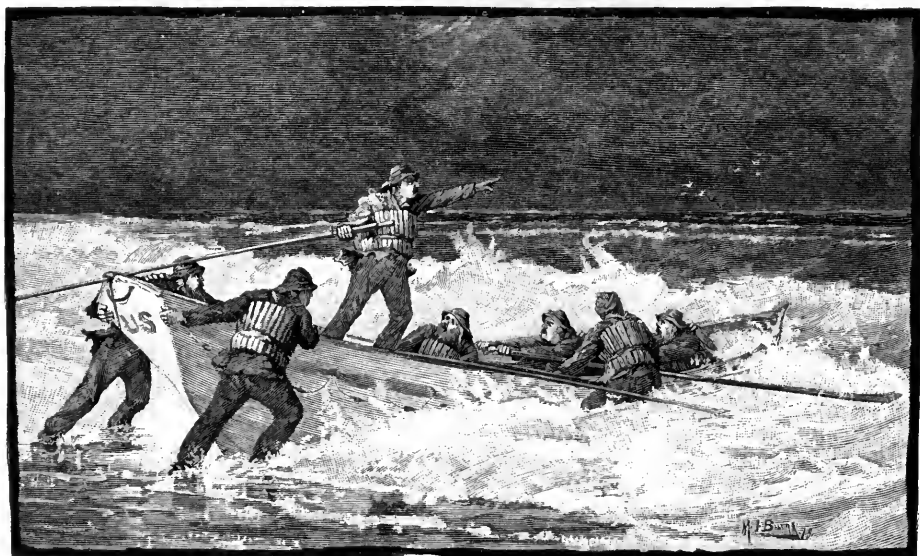

LAUNCHING THE SURF-BOAT.

observe the slightest indication of a disaster: the glimmer of a light, the white apparition of a sail, the faint outline of a slender spar just beyond the breakers, or at his feet on the strand perhaps a grating, a bucket, or

mile or two away. His hasty entrance is sufficient to arouse the slumbering inmates. Struggling for breath he makes his report, the nature of which determines to the keeper the means to be employed for the



THE NIGHT PATROL.

some other article which he knows to have come from a ship. Then with all his faculties bent to the search, he descries a vessel either too close in for safety or actually stranded in the breakers. In either case he burns his signal, whose crimson light flashes far out to sea, and warns the unwary ship to stand off, or assures the shipwrecked that aid is near at hand. Being certain it is a wreck, he hurries to his station, perhaps a

rescue. If the surf-boat is to be taken, at the word of command the wide doors of the boat-room are thrown open and the boat-carriage drawn by willing hands rolls out, bearing the graceful craft fully equipped for service. In the absence of horses, the burden must be hauled by the men, and their laborious task may be conceived, when it is stated that each man must drag nearly one hundred and eighty pounds

through soft, yielding sand, whatever the distance may be between the station and the wreck, while one hundred and fifty pounds is the estimated load for a man to draw over a level turnpike.

Arrived at the scene of the disaster, the boat is launched with as little delay as possible from a point opposite the wreck, in order to get the benefit of the slight breakwater which the position of the vessel affords, and is soon off and away on its errand of mercy. The height of human skill is required of the keeper standing at the steering oar to guide the boat safely in its passage through the wild running breakers. The surfmen, with their backs to the dangers lurking in the treacherous seas, do not go blindly to uncertain fate, for they rest their eyes continually upon the keeper, while they ply their oars in obedience to his commands, and mark his slightest gesture. Their first attempt is not always successful. Despite every care, a suddenly leaping sea may break, and fill the boat, compelling a return to the shore, or capsize her, tumbling the men into the water, where they are tossed about in the surf, but are sustained by their cork life-belts until making a foothold they struggle to the beach and righting the boat try again and perhaps a third or fourth time, before finally reaching the wreck. Here the most careful maneuvering is necessary to prevent collision of their light craft against the huge hull of the stranded vessel, or to avoid fatal injury from falling spars and floating wreckage. Taking off as best they can the anxious people, whom the overwhelming seas have driven into the rigging of the vessel, perhaps fast going to pieces, the difficult return to the shore remains before them. The keeper must now decide upon one of several methods of landing, as the nature of the sea may demand. Under favorable conditions he may run in immediately behind a roller, and by quick work keep well ahead of the following one, and so reach the beach in safety. With a different sea he may back in, occasionally pulling ahead to meet an incoming breaker; and again, for a worse sea he may use a drag to check the headway with which a swift rolling comber would otherwise carry the boat high upon its summit until a portion of the keel would be out of water, the bow high in the air and the stern still resting upon the crest,—from which position, on account of the slight hold the boat has in the water, the sea behind is liable, in spite of the efforts of the steersman, to turn it to the right or left, causing it to

“broach to” and capsize, or if this be avoided, perhaps to be “pitch-poled,” end over end.

When the patrolman has reported at the station that the boat cannot be used, the mortar-cart is ordered out. Like the boat-carriage it must be drawn by the men, and though the load is somewhat lighter, the state of the sea or the weather increases the labor; the one compelling them to take a route close to the low sand-hills in the wash and foam of the spent breakers, or back of the hills in the looser sand by a circuitous course, and the other harassing and retarding them with its fury. Reaching at length their destination, each man, well trained in his duties, proceeds to handle and place in position the portion of the apparatus assigned to his special charge. Simultaneously the different members of the crew load the gun, place the shot-line box in position, dispose the hauling lines and hawser for running, attach the breeches-buoy, put the tackles in place ready for hauling, and with pick and spade begin the digging of a trench for the sand-anchor, while the beach lantern lights up the scene.

And now the gun is fired! The shot



BURNING A SIGNAL.

with its line goes flying against the gale, over the wreck into the sea beyond; the line falls across a friendly spar or rope, and is soon seized by the eager benumbed hands of the imperiled sailors, whose glad shouts, faintly heard on shore, make known to the life-savers their success. The surfmen connect the whip (an endless line), the tail-block and tally-board to the shot-line already being hauled in by the impatient sailors. The whip passes rapidly toward the wreck, and arriving there the sailors make fast the tail-block in accordance with the directions on the tally-board and show a signal to the shore. Hauling upon one part of the whip, the surfmen then send on board, attached to the other part, the hawser and a second tally-board, which directs how and where the end of the hawser should be secured to the wreck. The tackles now connecting the sand-anchor and the shore end of the hawser are hauled upon until the hawser is straight and taut, when it is lifted several feet in the air, and further tightened by the erection of a wooden crotch, which constitutes a temporary pier while the wreck answers for another, and the hawser stretched between the two suggests a suspension bridge in an early stage of construction with but one cable in place. The breeches-buoy is drawn to and fro on the hawser, and by means of it the shipwrecked are brought safely to shore.

This method is expeditious when once well in operation, but is frequently attended with difficulties which evoke every resource and expedient. Often in storms a strong swift current runs along the coast between the outer bar and the shore, called by the surfmen the "set" or "cut," which, in connection with the action of the surf, twists and entangles the lines, as the attempt is made to haul them across from shore to ship, or sweeps them away to a great distance, causing heavy strains that sometimes prove too much for their strength. Occasionally, when the apparatus is well set up for use, the motion of the wreck, as it is lifted and rolled about by the powerful seas, is so violent and constant that, even with the most watchful care, the strong lines snap and break asunder like pack-thread; and at times the careless or bungling manner in which those on board perform their part, allowing the shot-line or the whip to saw across the stiff rigging of the vessel, or chafe against other portions of the wreck until it parts, hinders the work or altogether prevents success. Now and then, in extreme cold

weather, the lines become rigid and clogged with ice as soon as they are exposed to the air when lifted out of the water; and again, unless proper care has been observed in the arrangement of the blocks and lines, the velocity with which the freighted ropes run through the blocks, may set on fire the wooden shells, or cases that contain the sheaves or pulley-wheels. These mishaps and reverses tax the patience and resources of the surfmen to the utmost, and often put their courage to the severest test. The breaking of the lines involves the toil and delay of the duplication of their work, and perhaps the anxious suspense necessitated by a return to the station for spare lines. Sometimes it is found necessary to abandon altogether the use of the hawser, and to draw the people ashore through the water with the whip and breeches-buoy, or even without the latter, the shipwrecked persons securing themselves into the whip by tying it around their bodies. In some of these contingencies people have been held suspended in the breakers or ensnarled in the floating cordage and *débris* of the vessel, and only extricated from their perilous positions by the most daring exploits of the surfmen who have worked themselves out through the surf, and, at the most imminent risk of their own lives, released the helpless beings from their bonds, or disentangled them by severing the meshes with their knives, and returned, bearing their gasping trophies safely to the shore.

Other accidents and obstacles are likely to embarrass the efforts of the life-saving crews, who usually arrive at the scene of disaster exhausted by their wearisome march.

The breeches-buoy, although it is an exceedingly useful contrivance for bringing men ashore, is hardly a suitable one for transporting women and children, or for rescuing a large number of persons with dispatch, or invalids whom it is necessary to protect from wet and exposure. In such cases the life-car is usually brought into requisition and used with the arrangement of ropes already described; or, as externally it is simply a covered boat, under favorable circumstances it may be drawn back and forth through the water by a line attached to each end. More frequently, however, it is connected with the hawser by a simple device, in such a manner as to permit it to float upon the water, while preventing it from drifting, in strong currents, too far from a direct course for the length of the hauling lines. The life-car is about two hundred



HAULING THE MORTAR CAR.

W. H. B. 1885

pounds heavier than the breeches-buoy, and accordingly increases to that extent the burden of apparatus to be brought to the scene of a wreck; but it has sufficient capacity for five or six adults, and has carried, at a single trip, nine half-grown children. Practically water-tight, but provided with means for supplying air, its passengers are landed dry and without serious discomfort. The occasions of its use have been numerous, and in one notable instance—the wreck of the *Ayreshire* below Squan Beach, on the coast of New Jersey—two hundred and one persons were rescued by it, when no other means could have availed. Silks, fine fabrics, jewelry, and other valuable goods have often been saved by its use, and from one vessel the car took ashore a large sum in gold bullion belonging to the United States, together with the mails.

The general features of the Lake and Pacific coasts admit of the use of the self-righting and self-bailing life-boat. On the Lakes the stations are situated, with few exceptions, at, or very near, commercial towns, or cities having artificial harbors. These harbors are formed at the mouths of rivers by long piers projecting some distance into the lake. The passages between the piers are quite narrow and difficult to enter when high seas are running at right angles to them; thus vessels in attempting to go in are frequently thrown out of their course at the critical moment and are cast upon the end of a pier to quick destruction, or, escaping that danger, are driven ashore outside. Here the self-righting and self-bailing life-boat is used with good effect. This marvelous product of inventive thought, which has been developed by a century of study and experiment, from the first model, designed by the English coach-maker, Lionel Lukin, in 1780, is the best life-boat yet devised. It has great stability, and is with difficulty upset, but when this happens, it instantly rights itself, and when full of water empties itself in from fifteen to twenty seconds. The attainment of the first of these wonderful qualities is secured by means of a heavy iron keel, weighing from six hundred to fifteen hundred pounds, according to the size of the boat, and two large air-chambers placed in the bow and stern—the keel, when the boat is capsized, being drawn by the force of gravitation back toward and into the water, while the submerged air-chambers seek the surface at the same moment. The property of self-bailing is produced by the insertion of a deck or floor, some inches

above the load-line, in which there are placed several tubes extending down through the bottom of the boat, fitted with valves at the top, which open downward by the pressure of any water in the boat, and



SURFMAN WITH LIFE-BELT.

are self-closing when the pressure ceases. The draught and great weight which the construction of such a boat involves—the smallest weighs scarcely less than four thousand pounds—generally preclude its use, as has been stated, along the sandy flat beaches of the Atlantic. The Lake stations being inside the harbors and fronting directly upon or over comparatively smooth and sufficiently deep water, the heavy boats launched directly from their ways, are propelled by eight oars, or towed by a tug-boat out between the piers to the rescue. Not unfrequently, just before navigation is suspended by winter on the Lakes, a single life-saving crew is employed upon several vessels at a time. Recently four wrecks occupied half a station crew in the vicinity of their station on the same day, while the remainder were at work on a fifth, forty miles away, whither they had been transported by rail, on a special train secured for the occasion. It is a common occurrence for the life-boats to go under sail and oars ten or twelve miles from their stations to the

assistance of vessels in distress. On the Pacific coast, where the prevailing gales blow along and not upon the shore, and where there are few outlying dangers, and these at long intervals apart, coast disasters are comparatively rare, and it has been deemed necessary to provide for the establishment of but eight stations. With one exception, these are at points where the self-righting and self-bailing life-boat is available.

But the work of the crews does not always end with the rescue. The pressing necessities of the moment administered to, the sufferers are led, supported, or carried, as their condition will admit, to the station, which is quickly transformed into a hospital. The neglected fire is replenished with fuel; the kitchen stove soon glows with heat; the plethoric clothes-bags and well-filled chests of the surfmen are opened, and dry clothing is put upon all that need it; snow and cold water, and afterward scrapings of raw potatoes from the mess stores, are applied to the frost-bitten; the prostrated are put to bed in the extra cots provided in the upper rooms, and tenderly tucked in by rough hands, suddenly grown gentle; the medicine chest, filled

shipwrecked and surfmen are inhaling the delicious aroma of boiling coffee, which the mess-cook deems it his first duty to prepare. This having been partaken of, the keeper designates the least weary of the crew to attend to the wants of the strangers, while the others retire for rest until required to relieve the watch.

Occasionally, in the exigencies of shipwreck, persons reach the shore senseless and seemingly without life. That the surfmen may be able to act intelligently in such cases, the regulations of the service contain plain directions for the application of a simple method for restoring the apparently drowned, in which the men are regularly practiced, according to the instructions of a medical officer of the Marine Hospital Service, who visits the stations once a year as a member of the board for the examination of the keepers and crews, as to their physical and professional qualifications. The principal features of the method are indicated by the cuts on page 336, one showing the first step taken, by which the chest is emptied of air, and the ejection of any fluids that may have been swallowed is assisted;

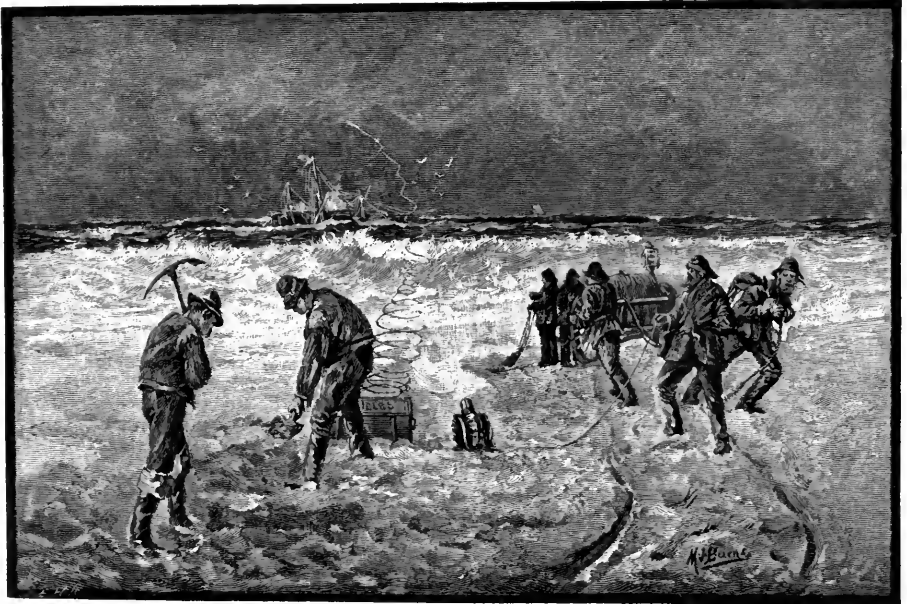

FIRING THE MORTAR.

with simple remedies and restoratives, is opened, and stimulants dispensed to the exhausted, while plasters, lint, and bandages are applied to those who have been bruised and wounded by the wreckage. Meanwhile,

and the other the position and action of the operator, in alternately producing artificial expiration and inspiration, in imitation of natural breathing, which may be expected to ensue if the patient is not really dead.

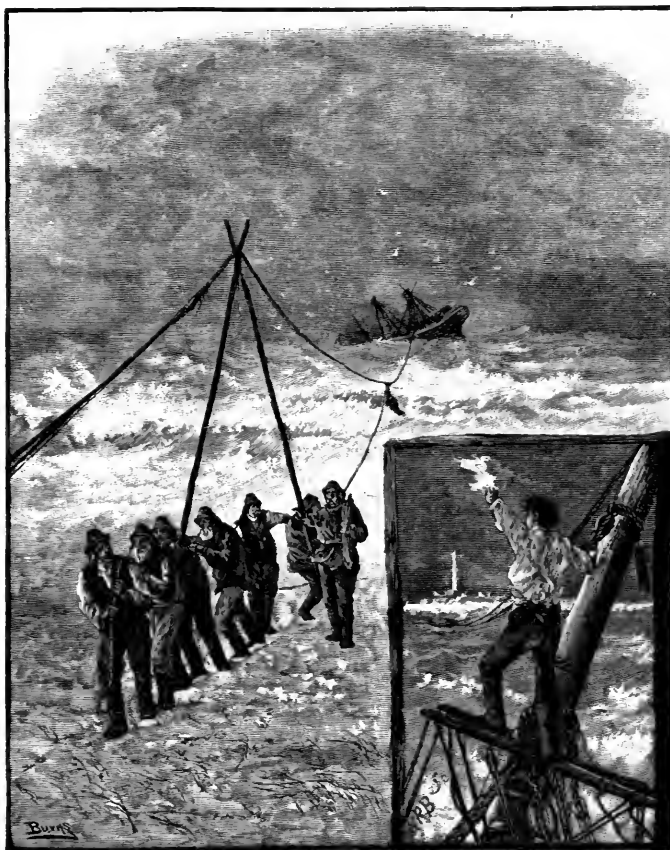

BREECHES-BUOY APPARATUS IN OPERATION.

"HAUL AWAY!"

There are many appliances auxiliary to the principal means employed in the operations of the service, of which space will not permit present notice. The life-saving dress, however, which has been made familiar to the public through the exploits and expeditions of Paul Boyton, is one of considerable importance, and on several occasions has been used with great advantage. At the stranding of a schooner in the night on Lake Ontario last year, in a sea which would not admit of the use of the boat, a shot-line was fired over her, with the intention of setting up the lines for the use of the breeches-buoy. The sailors hauled the whip-line on board, and when the tally-board, on which the directions for the method of procedure are printed in English on one side and French on the other, was received, the captain attempted by the light of a lantern to read them. Puzzling over them for some time, he at length contemptuously threw the board down on the deck, finding it impossible to make anything of it, having seen only the French side.

Not knowing what else to do, therefore, he simply made the line fast, but in such a manner that it could not be worked from the shore. The surfmen vainly endeavored to convey instruction by signs. In the meantime, the destruction of the vessel and the loss of all on board seemed imminent. In this dilemma, one of the surfmen put on the life-saving dress, and, after a gallant struggle, succeeded in hauling himself along the line through the breakers to the vessel, where he remained and took charge of the operations on board until all were safely landed. On another occasion three sailors, in spite of the warning signals of the life-saving crew, committed the common error of attempting to land in one of the ship's boats. A strong current was running between the ship and the beach, and the water was full of porridge-ice for a long distance from the shore. Knowing what would happen, two of the surfmen put on their life-saving dresses and ran up the beach, with difficulty maintaining their race with the boat, which continued for



THE BRECHES BUOY.

the distance of two miles, until reaching an open space in the ice, the sailors attempted to land, when they were capsized in the surf, but were rescued from drowning by the surfmen, who rushed into the breakers and safely dragged them ashore.

Clad in the life-saving dress, the wearer presents a strange appearance, and to an uninitiated observer he might seem, while engaged in his weekly practice, to be some amphibious monster, disporting one moment in the water and the next on land. Sometimes in cold weather, a surfman thus arrayed, goes on some errand from the station to the mainland, his route being an air-line across deep sloughs or creeks and wet marshes for two or three miles. A surfman once going

from an outlying beach in his life-saving dress, had just crossed a wide slough, and rising suddenly among the reeds on its muddy banks, beheld two snipe shooters a hundred yards away, gazing in undisguised astonishment. "I seen they was mighty skeered," said he, "and took me for the devil or some other sea varmint, so I be-ginned to cut up and prance round like a yearlin' calf in a two-acre medder, a-yellin' and a-screechin' all the time as loud as I could holler, and ye'd jest orter seen them fellers scoot fur the cedars. I guess they's runnin' yit." To a doubting Thomas who asked, "But whar was their guns all this time?" he replied: "Pshaw! them fellers never knowed they had no guns." The hunters' version of the adventure has never reached the beach, but it may easily be imagined.

When the life-saving dresses were first introduced into the service, the surfmen regarded them with as little favor as they usually manifest for any innovation upon the simple devices and methods which were transmitted to them from their fathers, especially as regards appliances for their own safety, such as life-belts and cork jackets. They prefer to rely upon their skill and endurance as swimmers, with unencumbered limbs and bodies. Probably, also, a certain degree of pride disinclines them to wear anything that might suggest the least suspicion of a faint heart. For a long time, to insure their use in the face of these prejudices, firm and judicious measures on the part of the officers of the service were required, and the life-belts were not willingly donned by the men throughout the service until they had been taught a sad lesson, by the capsizing of a surf-boat and the loss of the crew, who had gone to a wreck at night without them. Only recently, a brave volunteer, on taking an oar in a station boat, in a dangerous sea on Cape Cod, was proffered a spare life-belt but declined it, saying: "Oh, no! I don't want to go floating by Highland Light carrying a deck load of cork." The life-belt is manufactured from selected cork, and is so adjusted that the wearer has free use of his limbs in any position. Its buoyancy is sufficient to support two men in the water. Since its adoption by the men, none have been drowned, although many have been thrown into the water by capsized boats.

The life-saving men, of course, must have their hours of relaxation. Among the people of the coast, more than elsewhere,

perhaps, a pronounced religious sentiment prevails; hence, carousing and gaming and other immoralities are rarely indulged in. Especially is this true at the stations, where prohibitory regulations add their restraint. Each station is provided with a substantial library of well-selected books, the donations of generous people, with the view of contributing to the diversion of the crews and the solace of the victims of shipwreck who may be temporarily detained there. These libraries are the source of much entertainment and instruction to the men. In fine, clear weather, when the wind is off shore, and there is little occasion for anxiety, the surfmen gather in the mess-room and while away the time rehearsing the legends of the coast, spinning yarns, singing, or listening to the tuneful strains of violin or flute. Now and then, when the moon is full, there is a "surprise party" at the station. From the mainland or the neighboring settlements come men and women, the friends and relatives of the surfmen, bringing cakes and pastries, and other good things from their homes. Then all is joy unconfined; the boat-room is cleared of carriage and cart, and the merry dance goes round. Do not imagine, however, that in these festivi-

that, with wife or sweetheart to share his vigils, the patrolman yearns not for the pleasures at the station?

A mute but interested spectator of the entertainment is perhaps a Newfoundland dog. These noble animals, whose good qualities are so well known, are kept at many of the stations and they often seem instinctively to understand the object of the service, to which they soon become faithfully attached. The celebrated picture of Landseer, entitled "A Distinguished Member of the Humane Society," will readily be recalled by the reader. One remarkable illustration which the service furnishes of the characteristics of this sagacious animal is worthy of note. At the sad disaster to the steamship *Metropolis* on the coast of North Carolina, while the life-saving men were engaged in rescuing the crowd of passengers thrown into the sea by the breaking up of the vessel, a large Newfoundland dog belonging to a gentleman residing in the vicinity, seemed suddenly to comprehend the situation, and joining the throng of rescuers, plunged into the surf, seized a drowning man, and dragged him safely ashore. Shortly afterward he left his master and went to the station of the crew



THE SELF-RIGHTING LIFE-BOAT.

ties the patrol is relaxed. Not at all; the rule is inflexible, and its violation would be discovered. Indeed, who knows that the beach watch is not then doubled and

with whom he rendered this first service in life-saving, and there he still remains, steadily resisting every inducement to return to his former master. Every alternate night he

sets out with one of the first patrol and accompanies him until the patrolman from the next station below is met, when he joins the latter and proceeds with him to that station, where he remains until the first watch of the next night, when he returns to his own station in the same manner. These self-assumed duties he performs with the peculiar gravity of demeanor that distinguishes his species, changing his station daily, for some good and sufficient dog-reason, no doubt, while very sensibly keeping but one watch each night.

The plan of the organization of the service is simple but effective. The coast-line is divided into twelve districts, there being eight on the Atlantic coast, three on the

marine, make stated inspections and drill the crews. The entire service is under the charge and management of a general superintendent, whose office is a bureau of the Treasury Department. All the officers of the service are invested with the powers of customs officers, which enable them to protect the interests of the government in preventing smuggling, and assisting in securing the collection of duties upon dutiable wrecked goods. They are also required to guard wrecked property until the owners or their agents appear.

The officers and men of the service are chosen without reference to any other consideration than those of professional fitness and integrity. In the introduction and



THE SELF-RIGHTING LIFE-BOAT UNDER SAIL.

Lakes, and one on the Pacific. In each of these the stations are distinguished by numbers, from one upward, beginning at the most northerly or easterly. Each district is under the immediate charge of a superintendent, who must be a resident thereof, and familiar with the character and peculiarities of its coast-line. He nominates the keepers of the stations, makes requisition for needed supplies, etc., and pays the crews their wages. To each district is also assigned an inspector, who is the commanding officer of the revenue cutter whose cruising grounds embrace the limits of the district. These officers, under the direction of a chief inspector, who is also an officer of the revenue

maintenance of this principle of selection much opposition and difficulty have been encountered. In the older districts, owing to the fact that until 1871 the keepers of stations were regarded only as custodians of public property, without responsibility in the success or failure of efforts at wrecks, surfmanship was not a standard of qualification, and these positions were generally made the rewards of political service by each of the parties, as they alternately succeeded to power; and so, when the employment of crews was authorized, the local politicians endeavored to control the appointment of these also. Their success soon became only too evident, and it was to

counteract these injurious influences that the board of examination already mentioned was constituted. A thorough inspection of the service was made; every station was visited, the incompetent were dismissed, and qualified men were employed in their places. These advantageous changes in the corps somewhat altered its political complexion, and the nullification of the effort to subordinate the service to political ends was not quietly accepted. Threats and appeals were in turn resorted to, to overcome the determination of those in charge of the service. Upon the establishment of new districts, similar attempts to gain control of them are generally made, but they are not so tenaciously persisted in. These attempts are not confined to the party in power. No sooner is a keeper appointed by the opposition than he is beset with solicitations and demands to remember his party friends. The official injunction, however, issued yearly, at the commencement of the season, to the superintendents and keepers, that only capability and worth are to be regarded in the choice of their subordinates, supplemented by the action of the examining board, keeps the service well exempt from political domination.

But, it will be asked, what results have been attained by the service? At this writing, the last published report is that of the fiscal year ending June 30th, 1878. From this it appears



LIFE-SAVING DRESS.

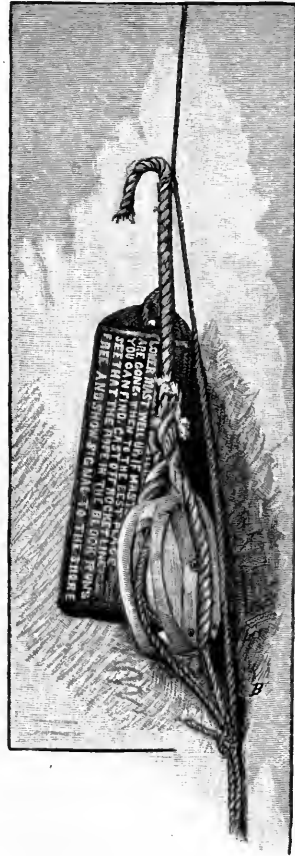

TALLY-BOARD AND WHIP-BLOCK.

that during that year there were 171 disasters to vessels within the limits of the operations of the service. There were on board these vessels 1,557 persons. The number of lives saved was 1,331, the number lost 226, and the number of days' succor afforded to shipwrecked persons at the stations was 849. Of the 226 lost, 183 perished at the disasters to the steamers *Huron* and *Metropolis*, the former occurring four days prior to the manning of the stations, which the appropriations for the maintenance of the service did not then permit to take place until the first of December, and the latter occurring at a distance so remote from the nearest station as to render prompt aid impossible;—defects which the reports of the service had repeatedly pointed out, and asked to have remedied. The loss of fourteen others occurred where service was impeded by distance, or where the stations were not open. Making allowance for these, the loss of life legitimately within the scope of life-saving operations, was twenty-nine.

The sad catastrophes of the *Huron* and *Metropolis* contributed largely in securing the passage of the effective bill of June, 1878, which was introduced and warmly advocated by Hon. S. S. Cox, and which

number of persons on board the vessels involved was 6,287; the number saved was 5,981; the number lost 306,† and the number of days relief afforded to shipwrecked persons at the stations, 3,716.



RESUSCITATION: EJECTING WATER FROM BODY.

established the service on a stable basis, with powers and functions somewhat commensurate with its purposes and capabilities.* From November, 1871, the date of the inauguration of the present system, to

It should be observed that during the first of these seven years the service was limited to the coasts of Long Island and New Jersey; the two following years, to those coasts, with the addition of Cape Cod;



RESUSCITATION: RESTORING RESPIRATION.

the 30th of June, 1878, the number of disasters stated to have occurred within the field of operations of the service was 578; the

the next year, to the foregoing, with the addition of the coasts of New England and the coast from Cape Henry to Cape Hatteras; the next, to the foregoing, with the ad-

* In this connection, acknowledgments are also due to the Hon. Charles B. Roberts, who made an exhaustive report upon the subject from the Committee on Commerce, seconded by an extremely able speech. The measure was also warmly supported by the Hon. Messrs. Covert, Conger, Yeates, Crapo, Dunnell, Brogden, Pugh, and others. In previous years the service was also much indebted

to Senators Stockton, Hamlin, Boutwell, Chandler and Frelinghuysen, and to Representatives Newell, Haight, Lynch, Hale of Maine, Hooper, Cox and Conger.

† This number includes the 183 persons who perished at the wrecks of the *Huron* and *Metropolis* and the 14 others above referred to.

dition of the coast from Cape Henlopen to Cape Charles; the next, to all the foregoing, with the addition of Florida and the lake coasts; and the last year, to the coast at present included.

It is not claimed that the entire number of persons designated in the above figures as saved would have perished but for the aid of the life-saving crews, since not unfrequently, in cases of shipwreck by stranding, a portion of the imperiled succeed in escaping to the shore, as did several in the instance of the *Huron*; and it often happens that the sudden subsidence of the sea spares the threatened vessels from destruction. But it is certain that a large proportion of the number would have perished. A closer approximation to the real efficacy of the service could be reached, if statistics of the loss of life in former years upon the coasts where life-saving stations are now established could be obtained. Unfortunately no such record exists, except an imperfect one, consisting of meager data relative to disasters between 1850 and 1870 in the vicinity of the rude station-huts of the Long Island and New Jersey coasts. It is known that this record by no means includes near all the disasters which occurred on these coasts. A comparison, however, of the record of the service since

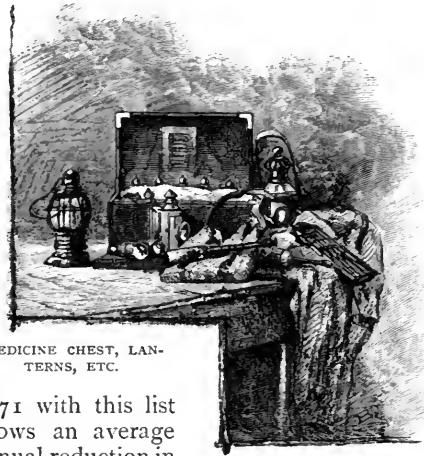

MEDICINE CHEST, LANTERNS, ETC.

1871 with this list shows an average annual reduction in the loss of life of about 87 per cent!

The record is a shining one. How much of it is due to official organization may readily be conceived, but it is less easy to realize how much of it belongs to the gallant crews of the stations, some of whose hardships, together with the methods they employ, the foregoing pages disclose. The professional skill of these men, their unflinching energy and endurance, their steady bravery in the hour of supreme ordeal, and at all times their sober fidelity to duty, however



THE MESS-ROOM, "WHEN THE WIND IS OFF SHORE."

hard or irksome, are beyond all tribute. None can better know it than the officers in charge of the service, whose main reliance must be, after all, upon the manly virtue of these crews. What, indeed, can ever stand in lieu of men!

Many things are yet needed in aid of the labors of the crews. Numerous articles of outfit and equipment are required, which the appropriations, so far, have not been sufficient to provide; an imperative need is an additional man for each station; at present, when a wreck occurs, the station is left without a proper custodian, who would thus be provided to guard the public property and to keep the house in the state of comfortable preparation befitting the return from a rescue of the exhausted crew, with a convoy of drenched, frozen, wounded, and famished people. In the routine of station duty, another man would also greatly relieve the others, now too severely tasked. Another urgent requirement at many of the stations is horses, which Congress should provide. The heavy draught labors involved in hauling a ponderous load of apparatus for miles to a wreck would thus be spared the men, giving them time and

strength for their daring and perilous work of rescue. Another need, surely, is pensions for those who are permanently disabled in the line of their duty, and for the widows and orphans of those who perish in the endeavor to save life from shipwreck. The guns trained to destroy life in the service of the country carry this grateful condition. The guns trained to save life, no less in the service of the country, have an equal right to carry it also. What soldiers have a better claim to this form of public remembrance than the noble beachmen who surrender life, as did those in North Carolina, in 1876, when endeavoring to rescue the sailors of the *Nuova Ottavia*?

In the thought of this deed let us close. A gallant soul whose name honors the rolls of the Life-Saving Service, once said: "When I see a man clinging to a wreck, I see nothing else in the world, and I never think of family and friends until I have saved him." It is certain that this is the spirit which pervades the men of the coast. All report, all record testifies to it, and every winter their deeds sublimely respond to the divine declaration: "Greater love hath no man than this, that a man lay down his life for his friends."

SUCCESS WITH SMALL FRUITS. III.*

STRAWBERRIES FOR HOME AND MARKET.

WHEN SHALL WE PLANT?

NATURE has endowed the strawberry plant with the power of taking root and growing readily at almost any season when young plants can be obtained. My best success, however, has been in November and early spring. The latter part of May and the month of June is the only time at which I have not planted with satisfactory results. In northern latitudes early spring is preferable, for at this season the ground is moist, showers are abundant, and the impulse of growth is strong. The weather is cool also, and therefore the plants rarely heat or dry out during transportation.

In the south, autumn is by far the best time to plant. When the young plants are grown on the same place they may be transferred to the fruiting beds and fields any time between July and the middle of November. The earlier they are set out, if they can be

kept growing during the remainder of the hot season, the larger will be the yield the following spring. As a rule, plants cannot be shipped from the north to the south until cool weather. The forwarding to the latitude of Richmond begins in September, and to points further south in October and November; from Florida to Louisiana I hear of almost unvarying success.

Of late years the practice of growing plants in pots, and sending them out as the florists do flowers has become very prevalent. These potted plants can be set out in July, August, and September, and the ball of earth clinging to their roots prevents wilting, and, unless they are neglected, insures their living. Pot-grown plants are readily obtained by sinking two and a half or three inch pots up to their rims in the propagating beds, and filling them with rich earth mingled with old thoroughly rotted

* In the illustrations of this paper the berries are drawn from nature and are represented at their actual size.

compost, leaf mold, decayed sods, etc., but never with fresh unfermented manure. I have found the admixture of a little fine bone meal with the soil to be a strong aid to vigorous growth. The young runners are then so guided and held down by a small stone or lump of earth, that they will take root in the pots. In about two weeks they fill the pots with roots, which so interlace as to hold the ball of earth compactly together during transportation. This ball of earth with the roots separates readily from the pot, and the plant, thus sustained, could be shipped around the world if kept from drying out and the foliage protected from

cal flavors, we can set out the plants in the summer or autumn of the same year and within eight or ten months gather the fruits of our labors. If the season is somewhat showery, or if one is willing to take the trouble to water and shade the young plants, ordinary layers, that is, plants that have grown naturally in the open ground, will answer almost as well as those that have been rooted in pots. The fact that they do not cost half as much is also in their favor.

As the autumn grows cool and moist, layer plants can be set out profitably in large quantities. The chief danger in late planting results from the tendency of the plants to



POTTING RUNNERS.

the effects of alternate heat and cold. The agricultural editor of the "New York Weekly Times" writes me that the potted plants are worth their increased cost, if for no other reason, because they are so easily planted in hot weather.

The chief advantage of summer planting lies in the fact that we obtain a good crop the following season, while plants set out in spring should not be permitted to bear at all the same year. If we discover in May or June that our supply is insufficient, or that some new varieties offer us paradisai-

be thrown out of the ground by the action of the frost, and a few varieties do not seem sufficiently hardy to endure severe cold. I obviate this difficulty by simply hoeing upon the plants two or three inches of earth just before the ground freezes in November or December. This winter covering of soil enables me to plant with entire success at any time in the fall—even late in November—instead of spring, when there is a rush of work. The earth is raked off the plants in March or April, as soon as severe freezing weather is over; otherwise they would decay.



STRAWBERRY BLOSSOMS: PERFECT-FLOWERED, AND PISTILLATE.

Varieties most heralded to-day will soon exist only in name. The reasons can readily be given. The convex heart of every strawberry blossom will be found to consist of pistils, and usually of stamens ranged around them. When both stamens and pistils are found in the same blossom, as is the case with most varieties, it is called a perfect flower; but there are occasionally strawberry flowers which possess stamens without pistils, and far more often others which have pistils without stamens, and either of these two if left alone would be barren; the staminate or male flowers are always so, but the pistillate or female flowers, if fertilized with pollen from perfect-flowered plants, produce fruit. This fertilizing is effected by the agency of the wind or by insects seeking honey.

The ovule in the ovarium to which the stigma leads, represents, at maturity a seed

—the actual fruit of the strawberry
—and within each seed Nature, by a subtle process of her own, wraps up some of the qualities of the plant that produced the seed and

WHAT KINDS SHALL WE PLANT ?

By consulting treatises upon strawberry culture we find that every one of the best catalogues very soon loses all value except as history.

some of the qualities also of the plant from which came the pollen that impregnated the ovule.

This seed planted produces an entirely new variety, which as a rule exhibits characteristics of both its parents, and traits also of its grandparents and remote ancestors. The law of heredity is the same as in cattle or the human race. Thus it can be seen that millions of new varieties can be very easily obtained. A single plant-grower often raises many thousands, to which he never gives a name by reason of the fact—noted elsewhere than in the fruit garden—that most of these new strawberries in no respect surpass or even equal their parents. The great majority, after fruiting—which they do when two years old—are thrown away. A new variety which is not so good as the old ones from which it came should not be imposed upon the public. But they often are, sometimes deliberately, but far more often for other reasons; as for instance, through the enthusiasm of the possessor. It is *his* seedling: therefore it is wonderful. He pets it and gives it extra care, to which even very inferior varieties generously respond. Again, a fruit-grower sends out second and third rate kinds from defective knowledge. He has not judiciously compared his petted seedlings with the superb varieties already in existence. It is soon discovered by general trial that the vaunted new-comers are not so good as the old, and so they also cease to be cultivated, leaving only a name.

Among the innumerable candidates for favor, here and there one will establish itself



SHARPLESS SEEDLING AND WILD STRAWBERRY.

by persistent well-doing as a standard sort. We then learn that some of these strawberry princes, like the Jucunda and Triomphe de Gand, flourish only in certain soils and lati-

tudes, while others, like the Charles Downing and Monarch of the West, adapt themselves to almost every condition and locality. Varieties of this class are superseded very

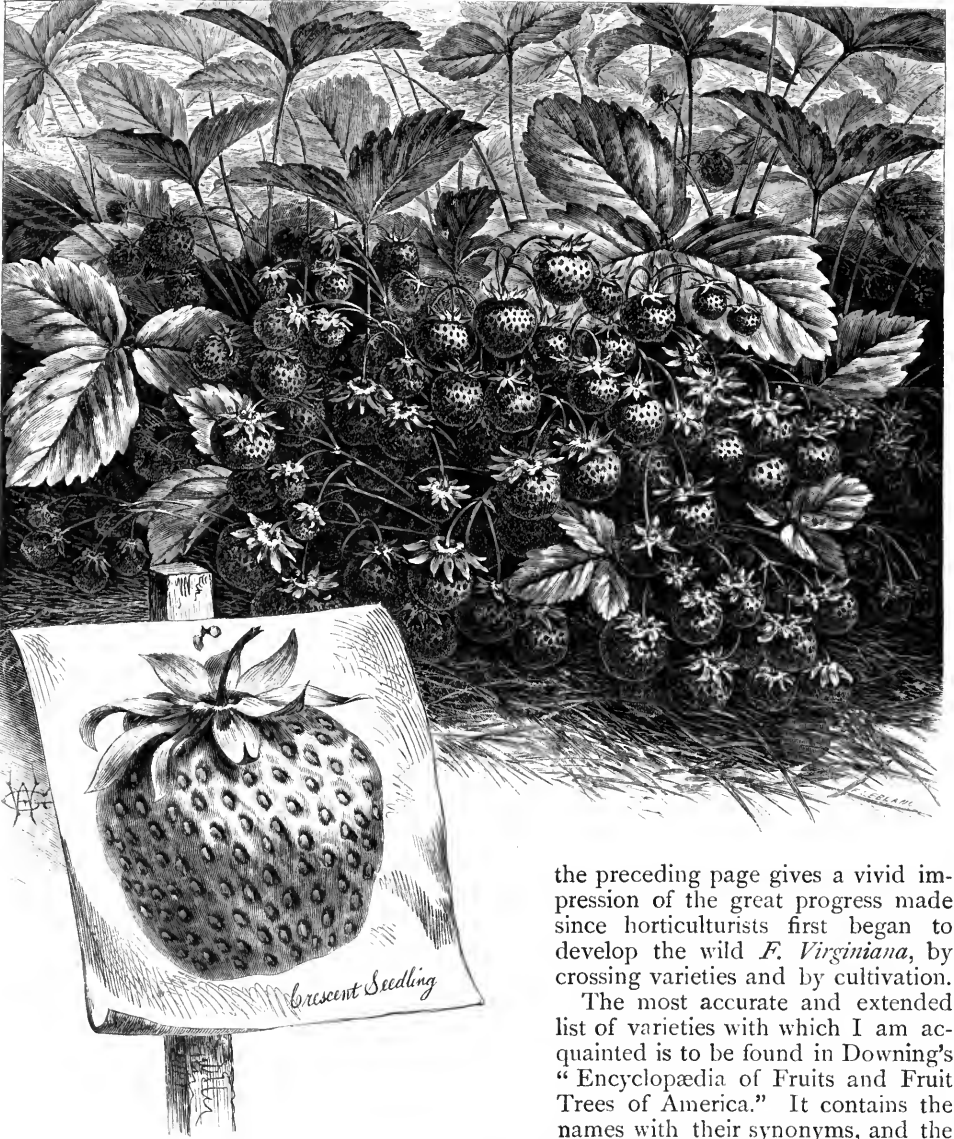

ROW OF PRODUCTIVE CRESCENT SEEDLINGS.

slowly; but it would seem, with the exception of Wilson's Albany and Hovey's Seedling, that the standards of one generation have not been the favorites of the next. The demand of our age is for large fruit. The demand has created a supply, and the old standard varieties have given way to a new class, of which the Monarch and Seth Boyden are types. The latest of these new mammoth berries is the Sharpless, originated by Mr. J. K. Sharpless, of Catawissa, Pa., and the life-size engraving of a cluster on

the preceding page gives a vivid impression of the great progress made since horticulturists first began to develop the wild *F. Virginiana*, by crossing varieties and by cultivation.

The most accurate and extended list of varieties with which I am acquainted is to be found in Downing's "Encyclopædia of Fruits and Fruit Trees of America." It contains the names with their synonyms, and the descriptions of over 250 kinds, and to this I refer the reader.

The important question to most minds is not how many varieties exist, but what kinds will give the best returns. In the brief limits of this paper I shall, therefore, confine myself to those sorts which, from trial and observation, I know to be excellent.

If one possesses the deep, rich, moist loam that has been described, almost any good variety will yield a fair return, and the best varieties can be made to give surprising results. For table use and general cultivation, north and south, east and west, I would

recommend Charles Downing, Monarch of the West, Seth Boyden, and Kentucky Seedling. These varieties are all first-rate in quality, and they have shown a wonderful adaptation to varied soils and climates. They have been before the public many years, and have persistently proved their excellence. Therefore, they are worthy of a place in every garden. With these valuable varieties for our chief supply, we can try a score of other desirable kinds, retaining such as prove to be adapted to our taste and soil.

If our land is heavy, we can add to the above, in northern latitudes, Triomphe de Gand, Jucunda, President Wilder, Forest Rose, President Lincoln, Golden Defiance, Sharpless, and Pioneer.

If the soil is light, containing a large proportion of sand and gravel, the Charles Downing, Kentucky Seedling, Monarch of the West, Duchess, Cumberland Triumph, Miner's Prolific, Golden Defiance and Sharpless will be almost certain to yield a fine supply of large and delicious berries, both north and south.

Let me here observe that varieties that do well on light soils also thrive equally

well and often better on heavy land. But the converse is not true. The Jucunda, for instance, can scarcely be made to exist on light land. In the south it should be the constant aim to find varieties whose foliage can endure the hot sun. I think that the Sharpless, which is now producing a great sensation as well as mammoth berries, will do well in most southern localities. It maintained throughout the entire summer the greenest and most vigorous foliage I ever saw. Miner's Prolific, Golden Defiance, Early Hudson, and Cumberland Triumph also appear to me peculiarly adapted to southern cultivation.

As we go north the difficulties of choice are not so great. Coolness and moisture agree with the strawberry plant. There the question of hardiness is to be first considered. In regions, however, where the snow falls early and covers the ground all winter, the strawberry is not so exposed as with us, for our gardens are often bare in zero weather. Usually it is not the temperature of the air that injures a dormant strawberry plant, but alternations of freezing and thawing. The deep and unmelting snows often



A CLUSTER OF PIONEER STRAWBERRIES.

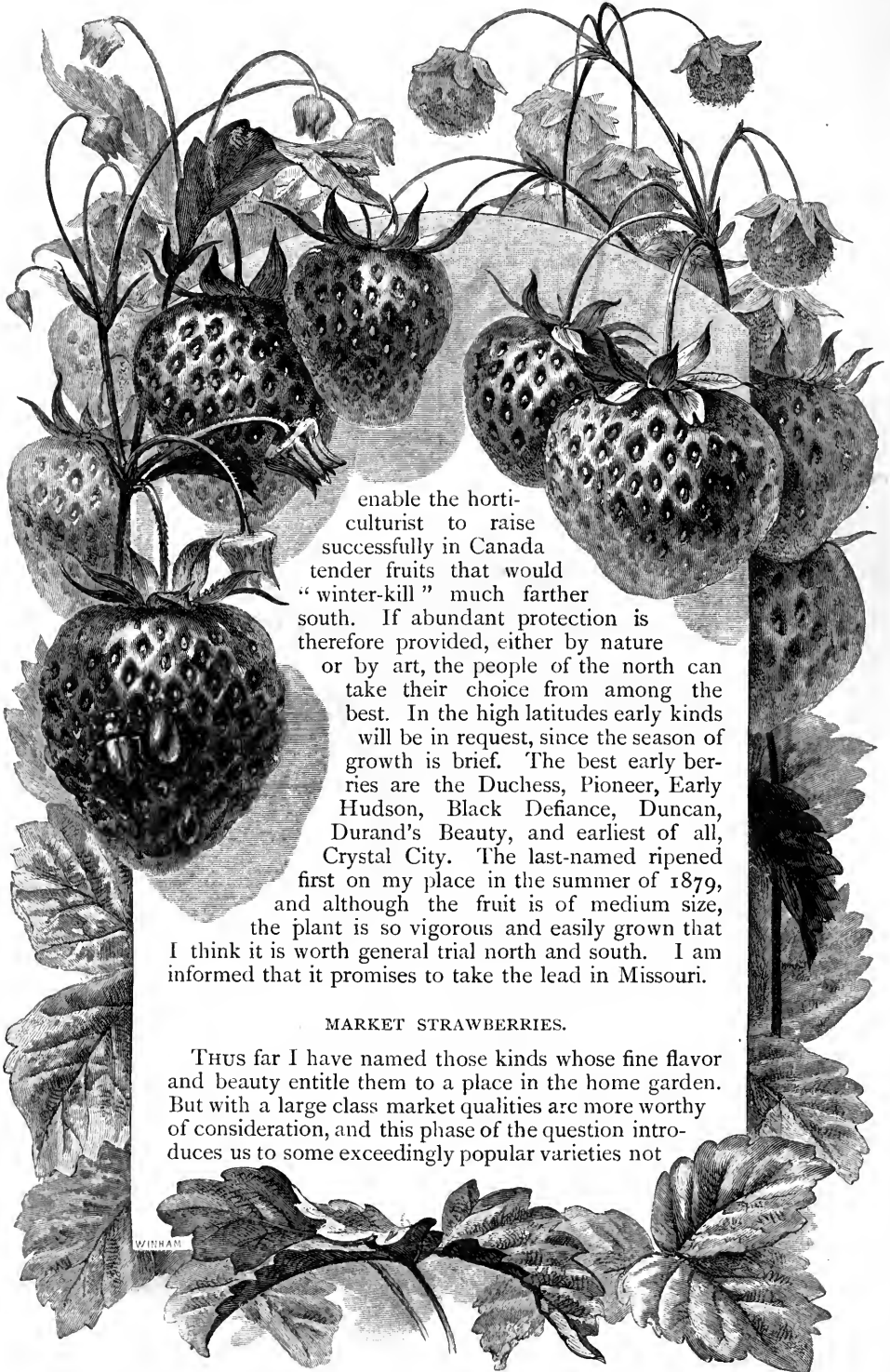

enable the horticulturist to raise successfully in Canada tender fruits that would "winter-kill" much farther south. If abundant protection is therefore provided, either by nature or by art, the people of the north can take their choice from among the best. In the high latitudes early kinds will be in request, since the season of growth is brief. The best early berries are the Duchess, Pioneer, Early Hudson, Black Defiance, Duncan, Durand's Beauty, and earliest of all, Crystal City. The last-named ripened first on my place in the summer of 1879, and although the fruit is of medium size, the plant is so vigorous and easily grown that I think it is worth general trial north and south. I am informed that it promises to take the lead in Missouri.

MARKET STRAWBERRIES.

Thus far I have named those kinds whose fine flavor and beauty entitle them to a place in the home garden. But with a large class market qualities are more worthy of consideration, and this phase of the question introduces us to some exceedingly popular varieties not

yet mentioned. The four great requirements of a market strawberry are productiveness, size, beauty, and—that it can endure long carriage and rough handling

producing smaller berries with each successive season. The Wilson is perhaps the best berry for preserving, since it is hard and its acid is rich and not watery.

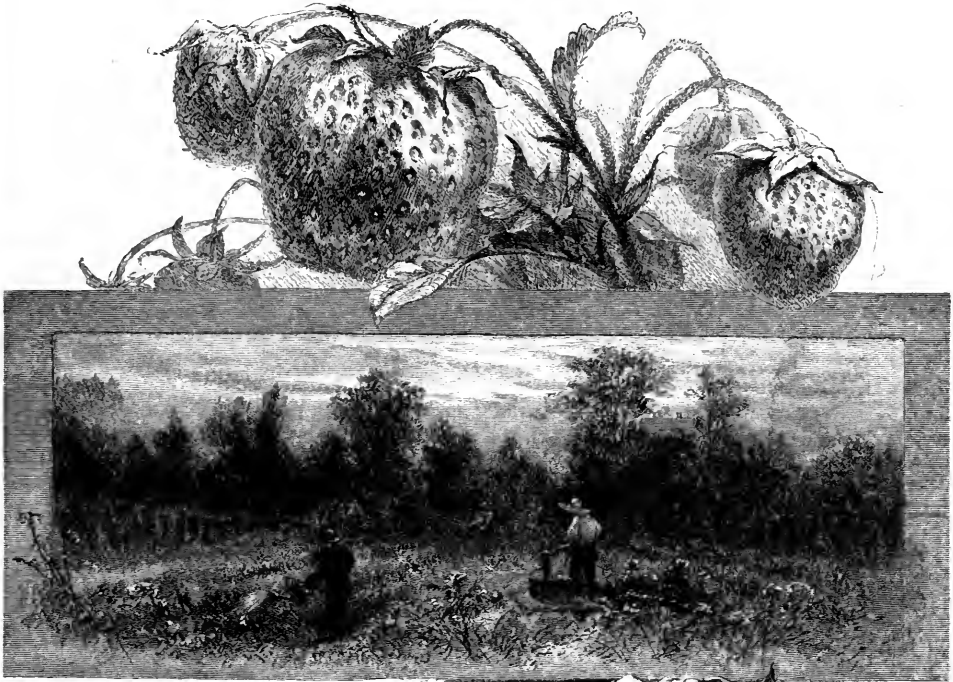

WATERING PLANTS IN THE TWILIGHT.

—firmness. Because of the indifference of the consumer, as explained in the first paper, that which should be the chief consideration—flavor—is scarcely taken into account. In the present unenlightened condition of the public, one of the oldest strawberries on the list—Wilson's Seedling—is more largely planted than all other kinds together. It is so enormously productive, it succeeds so well throughout the entire country, is such an early berry, that, with the addition of its fine carrying qualities it promises to be the great market berry for the next generation also. But this variety is not at all adapted to thin, poor land, and is very impatient of drought. In such conditions the berries dwindle rapidly in size, and even dry up on the vines. Where abundant fertility and moisture can be maintained the yield of a field of Wilsons is simply marvelous. On a dry hillside close by, the crop from the same variety may not pay for picking. Plantations of Wilsons should be renewed every two years, since the plant speedily exhausts itself,

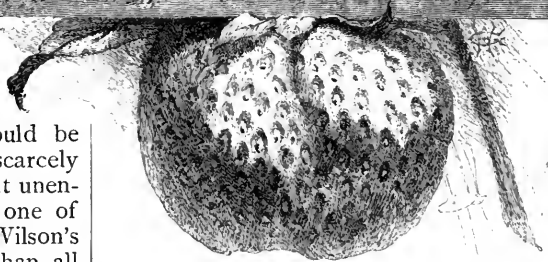

THE MONARCH OF THE WEST STRAWBERRY.

A rival of the Wilson has appeared within the last few years,—the Crescent Seedling, also an early berry, originated by Mr. Parmelee, of New Haven, Conn. At first, it received unbounded praise; now, it gets too much censure. It is a very distinct and remarkable variety, and, like the Wilson, I think, will fill an important place in strawberry culture. Its average size does not much exceed that of the Wilson; its flavor, when fully ripe, is about equal in the estimation of those who do not like acid fruit. In productiveness, on many soils, it will far exceed any variety with which I am acquainted. It is just this capacity for growing on thin,

poor soils—anywhere and under any circumstances—that gives to it its chief value. In hardness and vitality, it is almost equal to the Canada thistle. The young plants are small, and the foliage is slender and delicate; but they have the power to live and multiply beyond that of any other variety I have seen. It thrives under the suns of Georgia and Florida, and cares naught for the cold of Canada; it practically extends the domain of the strawberry over the continent, and renders the laziest man in the land, who has no strawberries, without excuse. The cut on page 342, showing one foot of the row in my specimen bed, indicates its productiveness. One of my beds yielded at the rate of 346 bushels to the acre, and the bright handsome scarlet of the berries caused them to sell for as much in the open market as varieties of far better flavor. It is too soft for long carriage by rail. Those to whom flavor and large size are the chief considerations will not plant it, but those who have a near and not very fastidious market, that simply demands quantity and fine appearance, will grow it both largely and profitably. The stamens of the Crescent are so imperfectly developed, that every tenth row in the field should be Wilsons or some other early and perfect-flowered variety.

In the Champion, we have a late market berry that is steadily growing in favor. On rich, moist land it is almost as productive as the Crescent. The fruit averages much larger than the Wilson, while its rich crimson color makes it very attractive in the baskets. The berries, like the two kinds already named, turn red before they are ripe, and in this immature condition their flavor is very poor, but when fully ripe they are excellent. The transformation is almost as great as in a persimmon. Under generous culture, the Champion yields superb berries, that bring the best prices. It also does better than most kinds under neglect and drought. It is too soft for long carriage, and its blossoms are pistillate.

The Captain Jack is another late variety, which is enormously productive of medium-sized berries. It is a great favorite in Missouri and some other regions. The berries carry well to market, but their flavor is second rate.

The good size, firmness, and lateness of the Glendale—a variety recently introduced—will probably secure for it a future as a market berry.

In the South, Neunan's Prolific, or the "Charleston Berry," as it is usually called,

is already the chief variety for shipping. It is an aromatic berry, and very attractive as it appears in our markets in March and April, but it is even harder and sourer than an unripe Wilson. When fully matured on the vines, it is grateful to those who like an acid berry. Scarcely any other kinds are planted around Charleston and Savannah.

These six varieties, or others like them, will supply the first great need of all large markets—quantity. With the exception of the last, which is not productive in the north, and requires good treatment even in the south, they are productive under rough field culture. The fruit can be sold very cheaply and yet yield a fair profit. Only a limited number of fancy berries can be sold at fancy prices, but thousands of bushels can be disposed of at eight and ten cents per quart.

Still I would advise any one who is supplying the market thoroughly to prepare and enrich an acre or more of moist but well drained land, and plant some of the large showy berries like the Sharpless, Monarch, and Seth Boyden. If he has heavy rich soil, let him also try the Jucunda, President Lincoln, and especially the Triomphe de Gand. These varieties always have a ready sale, even when the market is glutted with common fruit, and they often command very high prices. When the soil suits them they frequently yield crops that are not so far below the Wilson in quantity. Fifty bushels of large handsome berries may bring as much or more than one hundred bushels of small fruit, while the labor and expense of shipping and picking is reduced one-half.

I should not be at all surprised if the Charles Downing became one of the most popular market strawberries of the future. It is already taking the lead in many localities. It is moderately firm—sufficiently so, with a little extra care, to reach most markets in good condition. It is more easily raised than the Wilson, and on thin, dry land is more productive. A bed will last, if kept clean, four or five years instead of two, and yield better the fifth year than the first. Although the fruit is but of medium size, it is so fine in flavor that it has only to be known to create a steady demand. The Kentucky Seedling is another berry of the same class, and has the same general characteristics—with this exception, that it is a very late berry. In flavor it is melting and delicious. It does well on almost any soil, even a light and sandy one. It is usually very productive. These two old standard



WRONG METHODS OF PLANTING.

varieties which arch the page might also arch the continent, for they bring most of the best qualities of the best of fruits within reach of every market and home in the land.

The best white strawberry I have ever seen is Lennig's White. When exposed to the sun it has a decided pink flush on one side. It is beautiful and delicious and so aromatic that a single berry will perfume

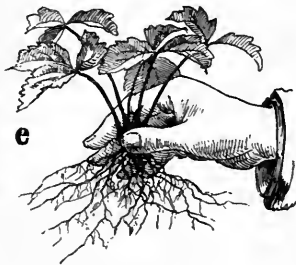

THE PROPER METHOD.

a large apartment. The fruit is exceedingly delicate, but the plant is a shy bearer.

In the White and Red Alpines, especially the ever-bearing varieties, and in the Haut-bois, we have very distinct strawberries that are well worthy of a place in a gentleman's garden. From a commercial point of view they have no value. This may settle the question with the majority, but not a few of us like to plant many things that are never to go to market.

In conclusion, if I were asked what is the most beautiful and delicious strawberry in existence, I should name the President Wilder. Perfect in flavor, form, and beauty, it seems to unite in one exquisite compound the best qualities of the two great strawberry species of the world, the *F. Virginiana* and the *F. Chilensis*. The only fault that I have ever discovered is that, in many localities, it is not productive. No more do diamonds lie around like cobble-stones. It is, however, fairly productive under good culture and on most soils, and yet it is possible that

not one in a hundred of the *habitués* of Delmonico's has ever tasted it.

SETTING OUT PLANTS.

WE may secure good plants of the best varieties, but if we do not set them out properly the chances are against our success, unless the weather is very favorable. So much depends on a right start in life, even in a strawberry bed. There are no abstruse difficulties in properly imbedding a plant. One would think that, if a workman gave five minutes' thought and observation to the subject, he would know exactly how to do it. If one used his head as well as his hands, it would be perfectly obvious that a plant held as in Figure *e*, with its roots spread out so that the fresh, moist earth could come in contact with each fiber, would stand a far better chance than one set out by any of the other methods illustrated. And yet, in spite



ROOT PRUNING.

of all I can do or say, I have never been able to prevent very many of my plants from being set (as in Figure *a*) too deeply, so that the crown and tender leaves were covered and smothered with earth; or (as

in Figure *b*) not deeply enough, thus leaving the roots exposed. Many others bury the roots in a long, tangled bunch, as in Figure *c*. If one would observe how a plant starts on its new career, he would see

In the moist favorable weather of early spring a plant is almost certain to grow, no matter how greatly abused. It is almost as easy to set out a plant properly as otherwise. Let the excavation be made

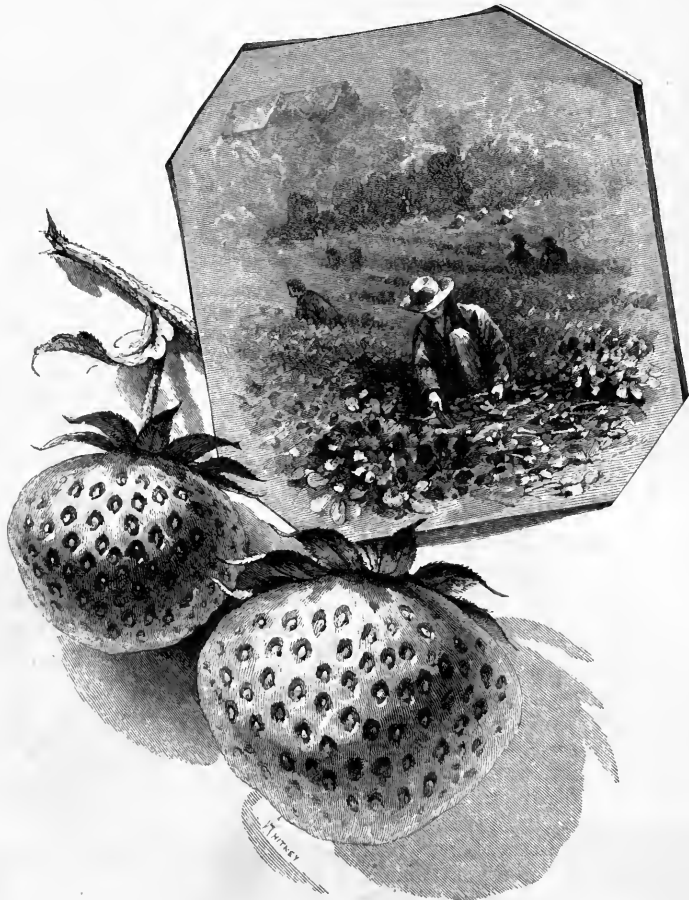

THE WILSON BERRY.

BOY WEEDING.

that the roots we put in the ground are little more than a base of operations. All along their length and at their ends little white rootlets start, if the conditions are favorable, almost immediately. If the roots are huddled together, so that only a few outside ones are in contact with the life-giving soil, the conditions are, of course, most unfavorable. Again, many planters are guilty of the folly illustrated in Figure *d*. They hastily scoop out a shallow hole, in which the roots are placed in the form of a half-circle, with the roots—which should be down in the cool, moist depths of the soil—turned up toward or to the very surface.

deep enough to put the roots, spread out like a fan, down their whole length into the soil. Hold the plant with the left hand as in Figure *e*. First, half fill the hole with fine rich earth with the right hand and press it firmly against the roots; next, fill it evenly and then with the thumb and finger of both hands, put your whole weight on the soil on each side of the plant—as close to it as possible—and press until the crown or point from which the leaves start is just even with the surface. If you can pull the plant up again by its leaves, it is not firm enough to the ground. If a man uses brain and eye he can learn to work very rapidly.

By one dexterous movement he scoops the excavation with a trowel. By a second movement he makes the earth firm against the lower half of the roots. By a third movement, he fills the excavation and settles the plant into its final position. One workman will often plant twice as many as another, and not work any harder. Negro women at Norfolk, Virginia, paid at fifty cents per day, will often set two or three thousand. Northern laborers ask more than twice that sum.

If the ground is so flat that water lies upon it at wet seasons, then throw it up into beds with a plow, thus giving the plants a broad, level surface on which to grow, for I think the best success will generally be obtained with level culture, or as near an approach to it as possible.

Always make it a point to plant in moist, freshly-stirred earth. Never let the roots come in contact with dry, lumpy soil. Never plant when the ground is wet and sticky, unless it be at the beginning of a rain-storm which bids fair to continue for some time. If sun or wind strikes land which has been recently stirred while it is too wet, the hardness of mortar results.

In spring, it is best to shorten in the roots one third (see cut on page 347). This promotes a rapid growth of new rootlets, and therefore of the plants. In the summer and fall the young plants are not so well furnished with roots, and usually it is best to leave them uncut.

the blackened shriveled ends. Sprinkle a couple of table-spoonfuls of fine bone meal immediately about the plant after setting, and then water it. If the weather is warm, soak the ground and keep it moist until there is rain. Never let a plant falter or go back from lack of moisture.

How often should one water? Often enough to keep the ground *moist all the time*, night and day. There is nothing mechanical in taking care of a young plant any more than in the care of a baby. Simply give it what it needs till it is able to take care of itself. This may require a little watching and attention for a few days in warm weather. If an opportune storm comes, the question of growth is settled favorably at once. If a "dry spell" ensues, be vigilant. At nine o'clock A. M. even well-watered plants may begin to wilt. Shade may be supplied by inverted flower-pots, old berry-baskets, shingles, or boards.

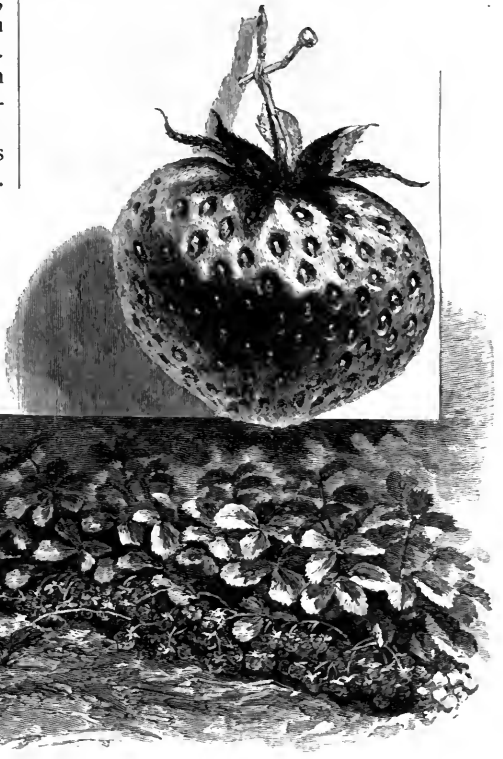

A DUCHESS ROW AND BERRY.

It often happens that during long transportation the roots become sour, black, and even a little mouldy. In this case wash them in clean water from which the chill has been taken. Trim carefully, taking off

A handful of weeds, grass, or even of dry earth, thrown on the crown of the plant in the morning, and removed by five P. M., is far better than nothing. Anything is better than stolidly sticking a plant in the

ground and leaving it alone just long enough to die. Many, on the other hand, kill their plants with kindness. They dose the young things with guano, unfermented manure, and burn them up.

As has been explained already, pot-grown plants, with a ball of earth clinging to their roots, can be set out during the hot months with great ease and with little danger of loss. At the same time let me distinctly say that such plants require fair treatment. The ground should be "firmed" around them just as strongly, and they should be so well watched as to guard against the slightest wilting from heat and drought.

In ordinary field culture let the rows be three feet apart, and let the plants stand one foot from each other in the row. At this distance, 14,520 are required for an acre. When land is scarce the rows can be two and a half feet from each other. In garden culture, where the plow and cultivator will not be used, there should be two feet between the rows, and the plants should be one foot apart as before. With this rule in mind, any one can readily tell how many plants he will need for a given area.

CULTIVATION.

THE field for experiment in cultivation with different fertilizers, soils, climates and varieties is indeed a wide one, and yet for practical purposes the question is simple enough.

There are three well-known systems of cultivation, each of which has its advantages and disadvantages. The first is termed the "matted bed system." Under this plan the ground between the rows is cultivated and kept clean during the spring and early summer. As soon however as the new runners begin to push out vigorously cultivation ceases, or else, with the more thorough, the cultivator is narrowed down till it stirs scarcely more than a foot of surface, care being taken to go up one row and down another so as always to draw the runners one way. This prevents them from being tangled up and broken off. By winter the entire ground is covered with plants, which are protected, as will be explained further on. In the spring the coarsest of the covering is raked off and, between the rows is dug a space about a foot or eighteen inches wide which serves as a path for the pickers. This path is often cheaply and quickly made by throwing two light furrows together with a corn plow. Under this system the first crop is usually the best, and

in strong lands adapted to grasses the beds often become so foul that it does not pay to leave them to bear a second year. If so they are plowed under as soon as the fruit has been gathered. More often two crops are taken and then the land is put in some other crop for a year or two before being planted with strawberries again. This rude, inexpensive system is perhaps more followed than any other. It is best adapted to light soils and cheap lands. Where an abundance of cool fertilizers has been used or the ground has been generously prepared with green crops, plowed under, the yield is often large and profitable. But as often it is quite the reverse, especially if the season proves dry and hot. Usually plants sodded together cannot mature fine fruit, especially after they have exhausted half their vitality in running. In clayey loams the surface in the matted rows becomes as hard as a brick. Light showers make little impression on it, and the fruit often dries upon the vines. Remembering that the strawberry's chief need is moisture, it will be seen that it can scarcely be maintained in a hard-matted sod. Under this system the fruit is small at best, and it all matures together. If adopted in the garden the family has but a few days of berries instead of a few weeks. The marketman may find his whole crop ripening at a time of over-supply, and his small berries may scarcely pay for picking. To many of this class the cheapness of the system will so commend itself, that they will continue to practice it until some enterprising neighbor teaches them better by his larger cash returns. In the garden, however, it is the most expensive method. When the plants are sodded together the hoe and fork cannot be used. The whole space must be weeded by hand, and there are some pests whose roots interlace horizontally underground and which cannot, therefore, be eradicated from the matted rows. Too often, therefore, even in the neatest gardens, the strawberry bed is the place where vegetable evil triumphs.

In direct contrast with the above is the "hill system." This, in brief, may be suggested by saying that the strawberry plants are set out three feet—more or less—apart, and treated like hills of corn, with the exception that the ground is kept level, or should be. They are often so arranged that the cultivator can pass between them each way, thus obviating nearly all necessity for hand work. When carried out to such an extent, I consider this plan more objectiona-

ble than the former, especially at the north. Modifications of this system often work well. In the first place, when the plants are so distant from each other much of the ground is left unoccupied and unproductive. In the second place, the fruit grower is at the mercy of the strawberry's worst enemy, the *Lachnosterna*, or white grub. Few fields in our region are wholly free from them, and a few of the voracious pests would leave the ground bare, for they devour the roots all summer long. In the third place, where so much of the ground is unoccupied by the labor of mulching, so that the soil can be kept moist and the fruit clean, is very great.

In small garden-plots, when the plants can be set only two feet apart each way, the results of this system are often most admirable. The entire spaces between them can be kept mellow and loose, and therefore moist. There is room to dig out and eradicate the roots of the worst weeds. By frequently raking the ground over, the annual weeds do not get a chance to start. In the rich soil the plants make great, bushy crowns that nearly touch each other, and as they begin to blossom the whole space between them can be mulched with straw, grass, etc. The runners can easily be cut away when

large, beautiful fruit, will be most satisfactory. Moreover, the berries, being exposed on all sides to the sun, will be of the best flavor.

In the south the hill system is the only one that can be adopted to advantage. There the plants are set in the summer and autumn, and the crop is taken from them the following spring. Therefore, each plant

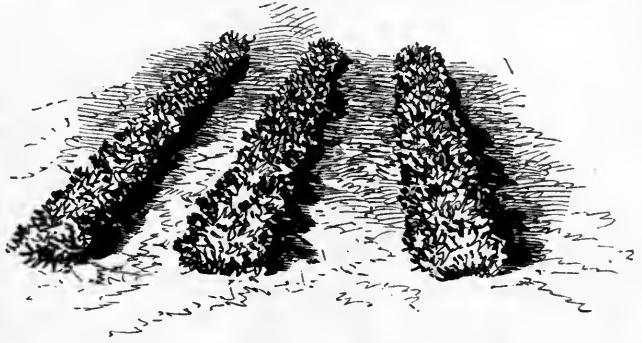

MATTED BED SYSTEM.

must be kept from running and be stimulated to do its best within a given space of time. In the south, however, the plants are set but one foot apart in the rows and thus little space is lost.

I am satisfied that the method best adapted to our eastern and western conditions is what is termed the "narrow row system." The plants are set one foot from each other in line, and not allowed to make

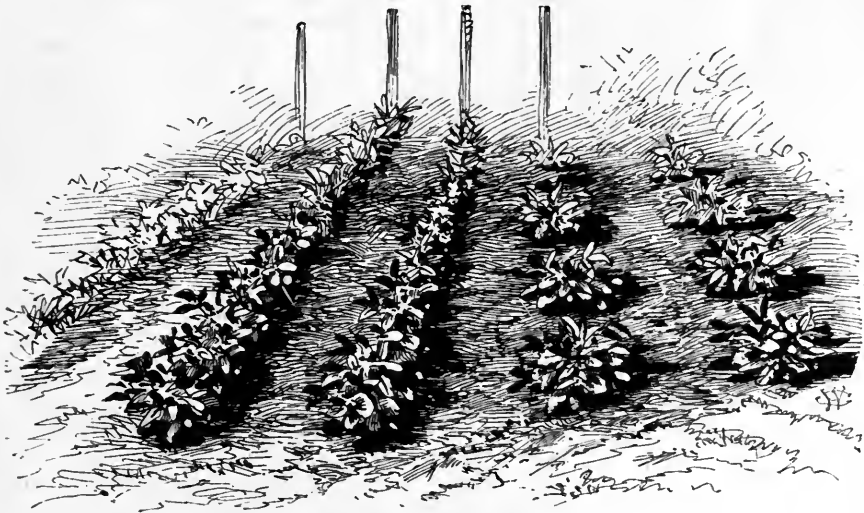

NARROW ROW AND HILL SYSTEMS.

the plants are thus isolated. Where there are not many white grubs in the soil, the hill system is well adapted to meet garden culture, and the result, in a prolonged season of

a single runner. In good soil they will touch each other after one year's growth, and make a continuous bushy row. The spaces between the rows may be two and a



THE FOREST ROSE STRAWBERRY.

CULTIVATION BY HORSE-POWER.

half to three feet. Through these spaces, the cultivator can be run as often as you please, and the ground can be thus kept clean, mellow, and moist. The soil can be worked—not deeply of course—within an inch or two of the plants, and thus but little space is left for hand-weeding. I have found this latter task best accomplished by a simple tool made of a fork-tine, thus: **T**. This can be thrust deeply between the plants without disturbing many roots, and the most stubborn weed can be pried out. Under this system the ground is occupied to the fullest extent that is profitable. The berries are exposed to light and air on either side and mulch can be applied with the least de-

gree of trouble. The feeding ground for the roots can be kept mellow by horse-power; if irrigation is adopted the spaces between the rows form the natural channels for the water. Chief of all, it is the most successful way of fighting the white grub. These enemies are not found scattered evenly through the soil, but abound in patches. Here they can be dug out if not too numerous, and the plants allowed to run and fill up the gaps. To all intents and purposes the narrow-row system is hill culture with the evils of the latter subtracted. Even where it is not carried out accurately, and many plants take root in the rows, most of them will become large, strong, and pro-

ductive under the hasty culture which destroys the greater number of the side-runners.

Where this system is fairly tried the improvement in the quality, size, and, therefore, measuring bulk of the crop, is astonishing. This is especially true of some varieties like the Duchess, which even in a matted bed tends to stool out into great bushy plants. The cut on page 349 shows how enormously productive it becomes under

fore, every runner that a plant makes means so much less and so much smaller fruit from that plant. Remove the runners as they appear, and the life of the plant goes to make vigorous foliage and a correspondingly large fruit-bud. Moreover, a plant thus curbed abounds in vitality and does not throw down its burden of prematurely ripe fruit after a few hot days. It works evenly and continuously as strength only can, and leis-



THREE ROWS, ILLUSTRATING EARLY SPRING WORK.

this system. Doctor Thurber, editor of the "American Agriculturist," unhesitatingly pronounced it the most productive and best early variety in a specimen bed containing fifty different kinds. If given a chance to develop its stooling-out qualities, it is able to compete even with the Crescent and Wilson in productiveness. At the same time its fruit becomes large and as regular in shape as if turned with a lathe. Many who have never tried this system would be surprised to find what a change for the better it makes in the old popular kinds, like the Charles Downing, Kentucky, and Wilson. The Golden Defiance also, which is so vigorous in the matted beds that weeds stand but little chance before it, almost doubles in size and productiveness if restricted to a narrow row.

The following remarks will have reference to this system, as I consider it the best. We will start with plants that have just been set out. If fruit is our aim we should remember that the first and strongest impulse of each plant will be to propagate itself, but to the degree that it does so it lessens its own vitality and power to produce berries the following season. There-

urely perfects the last berry on the vines. You will often find blossoms and ripe fruit on the same plant—something rarely seen where the plants are crowded and the soil dry.

With these facts before us, the culture of strawberries is simple enough. A few days after planting, as soon as it is evident that they will live, stir the surface just about them *not more than half an inch* deep. Insist on this; for most workmen will half hoe them out of the ground. After the plants become well rooted, keep the ground mellow and clean as you would any other hoed crop, using horse-power as far as possible, since it is the cheapest and most effective. If the plants have been set out in spring, take off the fruit buds as soon as they appear. Unless the plants are very strong, and are set out very early, fruiting the same year means feebleness and often death. If berries are wanted within a year the plants must be set in summer or autumn. Then they can be permitted to bear all they will the following season. A child with a pair of shears or a knife, not too dull, can easily keep a large garden plot free from runners, unless there are long periods of neglect.

If the ground were poor, or one were de-

sirous of large fruit, it would be well to give a liberal autumn top-dressing of fine compost or any well-rotted fertilizer not containing crude lime. Bone-dust and wood ashes are excellent. Scatter this along the rows, and hoe it in the last time they are cultivated in the fall. When the ground begins to freeze, protect the plants for the winter by covering the rows lightly with straw, leaves, or—better than all—with light, strawy horse-manure, that has been piled up to heat and turned over once or twice, so that in its violent fermentation all grass seeds have been killed. Do not cover so heavily as to smother the plants, nor so lightly that the wind and rains will dissipate the mulch. Your aim is not to keep the plants from freezing, but from freezing and thawing with every alternation of our variable winters and springs. Moreover, the thawing out of the fruit-buds or crown, under the direct rays of the sun, injures them, I think. Most of the damage is done in February or March. The good gardener watches his plants, adds to the covering where it has been washed away or is insufficient, and drains off puddles, which are soon fatal to all the plants beneath them. Wet ground, moreover, heaves ten times as badly as that which is dry. If one neglects to do these things, he may find half of the plants thrown out of the ground, after a day or two of alternate freezing and thawing. Good drainage alone, with three or four inches of covering of light material, can prevent this, although some varieties, like the Golden Defiance, seem to resist the heaving action of frost remarkably. Never cover with hot, heavy manure, nor deeply with leaves, as the rains beat these down too flatly. Let the winter mulch not only cover the row, but reach a foot on either side.

As the weather begins to grow warm in March, push aside the covering a little from the crown of the plants, so as to let in air. If early fruit is desired, the mulch can be raked aside and the ground worked between the rows, as soon as danger of severe frosts is over. If late fruit is wanted, let in air to the crown of the plants, but leave the mulch on the ground, which is thus shielded from the sun, warm showers, and the south wind, for two or three weeks.

I have now reached a point at which I differ from most horticultural writers. As a rule it is advised that there be no spring cultivation of bearing plants. It has been said, that merely pushing the winter mulch aside sufficiently to let the new growth come through is all that is needful. I admit that

the results are often satisfactory under this method, especially if there has been deep thorough culture in the fall, and if the mulch between and around the plants is very abundant. At the same time I have so often seen unsatisfactory results that I take a decided stand in favor of spring cultivation, if done properly and *sufficiently early*. I think my reasons will commend themselves to practical men. Even where the soil has been left mellow by fall cultivation, the beating rains and the weight of melting snows pack the earth. All loamy land settles and tends to grow hard after the frost leaves it. While the mulch checks this tendency, it cannot wholly prevent it. As a matter of fact, the spaces between the rows are seldom thoroughly loosened late in the fall. The mulch too often is scattered over a comparatively hard surface, which by the following June has become so solid as to suffer disastrously from drought in the blossoming and bearing season. I have seen well mulched fields with their plants faltering and wilting, unable to mature the crop because the ground had become so hard that an ordinary shower could make but little impression. Moreover, even if kept moist by the mulch, land long shielded from sun and air tends to become sour, heavy, and devoid of that life which gives vitality and vigor to the plant. The winter mulch need not be laboriously raked from the garden bed or field and then carted back again. Begin on one side of a plot and rake toward the other until three or four rows and spaces between them are bare; then fork the spaces or run the cultivator—often the subsoil plow—deeply through them, and then immediately, before the moist, newly made surface dries, rake the winter mulch back into its place as a summer mulch. Then take another strip and treat it in like manner, until the generous impulse of spring air and sunshine has been given to the soil of the entire plantation.

The cut on page 353, giving a section of my specimen bed, shows one row still under its winter covering, one cultivated and ready for the summer mulch, and a third row with this applied and the plants ready for fruiting. A liberal coat of fine compost was forked in also at the time, and the resulting crop was enormous. This spring cultivation should be done early—as soon as possible after the ground is dry enough to work. The roots of a plant or tree should never be seriously disturbed in the blossoming or bearing period, and yet I would rather stir the *sur-*

face, even when my beds were in full bloom than leave it hard, baked, and dry. A liberal summer mulch under and around the plants not only keeps the fruit clean, but renders a watering much more lasting by shielding the soil from the sun. Never sprinkle the plants a little in dry weather. If you water at all *soak* the ground and *keep* it *moist* all the time till the crop matures.

When prize berries are sought, enormous fruit can be obtained by the use of liquid manure, but it should be applied with skill and judgment, or else its very strength may dwarf the plants. In this case, also, all the little green berries, save the three or four lowest ones, may be picked from the fruit truss, and the force of the plant will be expended in maturing a few mammoth specimens. Never seek to stimulate with plaster or lime. Other plants' meat is the strawberry's poison in respect to these two fertilizers.

Horse manure composted with muck, vegetable mold, wood ashes, bone meal, and best of all, the product of the cow-stable, are the best fertilizers for the strawberry. Give plenty of these before and after planting.

After the fruit is gathered the beds should not be left to weeds and drought. I would advise that the coarsest of the mulch be raked off and stored for winter covering, and then the remainder forked or cultivated into the soil as a fertilizer. Many advise a liberal manuring after the fruit is gathered. This is the English method and is all right in their humid climate, but dangerous in our land of hot suns and long droughts. Dark-colored fertilizers absorb and intensify the heat. A sprinkling of bone dust can be used to advantage as a summer stimulant, and stronger manures containing a larger per cent. of nitrogen can be applied just before the late fall rains.

YOUNG ARTISTS' LIFE IN NEW YORK.

ILLUSTRATED BY THE SALMAGUNDI CLUB.

THE characteristics of the three leading art schools of the city,—the Art Students' League, the Academy of Design, and the Cooper Institute,—from the point of view of instruction, have already been described in this magazine.* Together, they may be looked upon as constituting three departments of a university, which holds out to the country at large, for all preliminary art studies at least, excellent opportunities. A very considerable proportion of the fifteen hundred students entered on the rolls are from the distant interior, and the number daily increases. There are many cases where the opportunity to study has been earned and is maintained by teaching or some other form of laborious work. One young woman at the Cooper copies manuscript half the night, in order to draw by day. A cold boarding-house existence takes the place of pleasant homes; sometimes two young women form a partnership to share it in common; sometimes they board themselves. Perhaps it is a couple from the same town,—sisters or friends,—one pursuing art and the other music. The young men adapt

themselves to circumstances more easily, and even with hilarity. In one case, three are encamped together in a large chamber where, though the total expense of living for each is kept down to three dollars a week, they entertain their friends and hold sessions of a flourishing glee-club.

So much for the day classes. Among the members of the night classes some outside occupation for support is regularly to be expected. It is usually something allied to art. Here are engravers, decorators, draughtsmen, carvers of ships' figure-heads, and even of cigar figures; but dry-goods and grocer's clerks are not unknown, toiling diligently till the joyful day of their deliverance from trade.

The association of the sexes on terms of perfect equality gives American art-student life one of its distinctive aspects; it is gentle and courteous, perhaps even tame according to some ways of thinking, but free, at any rate, from the wild and brutal excesses too well authenticated of famous foreign *ateliers*.

Glancing in at the Academy, one finds the students clustered together, in the order of proficiency, about the classic figures,—some

* See SCRIBNER for October, 1878.

around the masks and busts in the first alcove; others around the complicated groups in the third. There are reflective poses and moments of dreamy expression among the young workers at the easels, as they ponder subtleties of line and light and shade, of which the uninitiated have but a faint conception. In the hour of leisure at noon the beginner takes occasion to admire the genius of the delineator of the Laocoön, or the Silenus and Bacchus, in the third alcove, and aspires to parallel achievements. The young women lunch together in little knots,

quiring the use of the "bean-blower," in a poetic design for Harmony, showing an angel with the long straight classic trumpet, and—"Wait till I sling in an eye," he says, as he finishes the drawing of a charming face.

The year closes at the Academy with a dancing reception, following the distribution of prizes. The preceding day, which sees the clearing away of easels and other incumbrances, and the waxing of the floor in a more or less amateurish fashion, is something of a romp. On the eventful evening,



OFF FOR EUROPE. (DRAWN BY W. A. ROGERS.)

spreading out the viands informally in their laps. The young men go out to struggle for precedence in a certain popular bakery with the students from the medical college. The latest picture at Schaus's or Goupil's is discussed, or the work of other schools shown at some recent exhibition. There is nothing heavily oppressive in the daily conduct of affairs, though the underlying purpose is serious. Indeed, the art-student is inclined to a practicality and sometimes to an incorrigible levity of speech which makes it appear to be his direct purpose to disillusionize those who may have been inclined to sentimentalize about his exceptional position in our common-place life. He is capable of in-

the business-like working-aprons and the smudges of charcoal, which are rather a frequent accompaniment even on very lady-like countenances, have disappeared. The votaries of a great ideal meet one another now in the ordinary guise of polite society,—as bright and decorous a company as could be desired. The festival of the modern young people, with all the gods of antiquity in their immortal youth assembled around to witness it, is not without a certain quaint, agreeable incongruity.

The Cooper Institute has the most of a certain school strictness and routine, the entirely self-supported League the least. There is a pervading feeling of responsi-

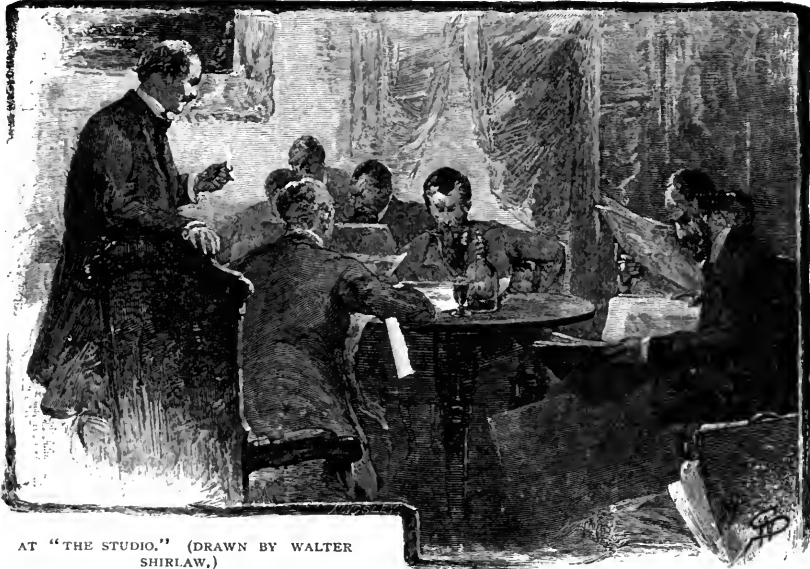

AT "THE STUDIO." (DRAWN BY WALTER SHIRLAW.)

bility among the members of the latter which much more than takes the place of it. Evening receptions are held once a month,

having for their occasion some small timely exhibition of sketches. These are artistic *conversazioni*, with quite an impressive gravity of tone.

While the work pursued at the League is of the most advanced character of the three, there are also perhaps more amateurs engaged. And yet this is not wholly a safe word to use: it is not easy to gauge the secret ambitions that may be cherished. The word having been applied inadvertently to one whose profession in life as a married lady with pretty children and an agreeable household seemed so unmistakable that there could hardly be a doubt that painting was with her a diversion, she protested:

"But it is precisely as a married lady with pretty children and an agreeable household, and not as an artist, that I consider myself an amateur."

Social distinctions are not rigidly drawn in this little artistic world. Nothing is so leveling as community in a great idea. A rating on the basis of individual ability generally takes the place of the ordinary gauges to consideration. There are ornaments of fashionable circles who come down to the schools and studios and form friendships with a cordiality which must be attributed by their more conventional acquaintances to quite a hopeless bohemianism.

An improving diversion outside the schools is the social sketch clubs, which from time to time flourish and fall into decadence. A congenial circle meets one evening

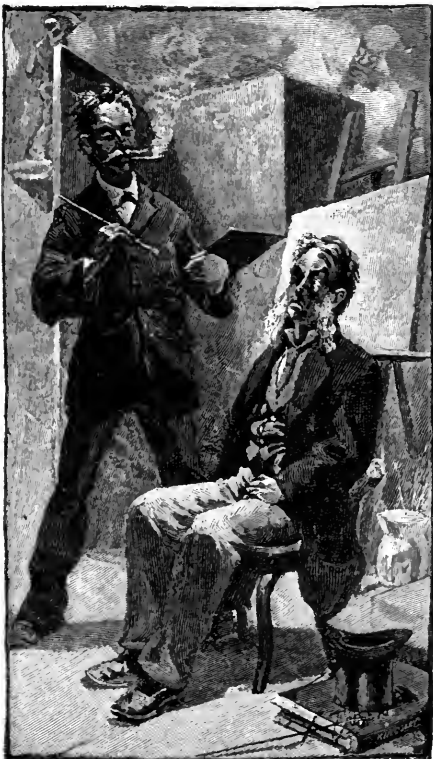

THE ARTIST IN BLACK EYES. (DRAWN BY W. TABER.)

a week from eight o'clock till ten, at the houses of members in turn, or at some one which offers peculiar advantages; the model is placed in a corner, often on a small improvised platform, and the ordinary chan-

received. When the time arrives for one after another (as it arrives now with increasing frequency) to carry his cherished dream into effect, it is the cause of a decided ripple of excitement. Contemplative glances rest

upon him during the few remaining days of his stay. When he comes to remove his properties and it is known that he appears for the last time, he is surrounded by an envious and admiring throng. In cases of especial regard the parting is more friendly and longer deferred. A merry party of both sexes is found awaiting the student among the boxes, bales, and hogsheads at the steamer pier. Perhaps it is a promising boy, whose family, making his talent the principal object of their care, go with him, to keep a home for him during his years of study. The fellows shake him heartily by the hand. All wave and shout parting injunctions to him. "There's Jim!" he cries at the last audible moment from the taffrail, half hidden behind a great blue handkerchief and a brandished sketch-book, singling out some particular character for recognition as they fade away. Then letters come back from him, profusely illustrated with the humors of the voyage, and, later, accounts of the *Beaux Arts*



BARGAINING FOR A "SHANGHAI." (DRAWN BY H. P. WOLCOTT.)

deliers serve well enough for purposes of illumination. Others hold morning sessions of three hours. At one which we have particularly in mind there were sometimes volunteer but generally paid models—make-believe fishermen, brigands, sultanas and dairy-maids, and real newsboys, coachmen, flower-girls and walking advertisements. At the ruling rates of payment for this kind of professional service,—fifty and seventy-five cents an hour,—the assessment of cost was not over ten cents to each person. The treasurer was inflexible in the collection of his dues, and there was often a humorous pretense of evading them. Often, when the last farthing was in, a collation appeared which would have defrayed the expenses of the club for several seasons.

The trip to Europe, for study in the great schools, is an almost universal ideal. Its advantages, the choice of the place, the cost at which it can be done, are topics of unflinching interest. Details of notable economies in living, often fabulous, are especially well

and the studio of the great master in which he has found a place.

As interesting—or perhaps even more interesting—a graduate, is the one who feels sufficiently strong to venture on the experiment of a studio. Usually it is a cheap and bare little place to begin with. He does not cut loose from the schools all at once, but frequents the more important life-classes, giving himself, on his occasional visits, airs of monumental importance, which the others are far from considering unwarranted. They are glad to visit him. They regard the modest details of his establishment respectfully, and are eagerly interested in his early methods of getting a living, for they desire to know what they have to look forward to when the case becomes their own.

Though there is no more delicate and charming sentiment than that which is the offspring of American life at its best, a strong practical vein is manifest in the American type of art-student. He has no traditions—no long hair and cloaks to adopt, and he has



A DISCOUNT TO THE PROFESSION. (DRAWN BY F. S. CHURCH.)

never been encouraged to feel that it is the business of any government or princely patron to take care of him. He is not, perhaps, quite enough given to seeking out romantic

and original experiences, though this is a trait not to be over encouraged. He has not discovered, for instance, the picturesque capabilities of New York, which has a glow



"YOUR WASHING, MUM." (DRAWN BY S. G. McCUTCHEON.)

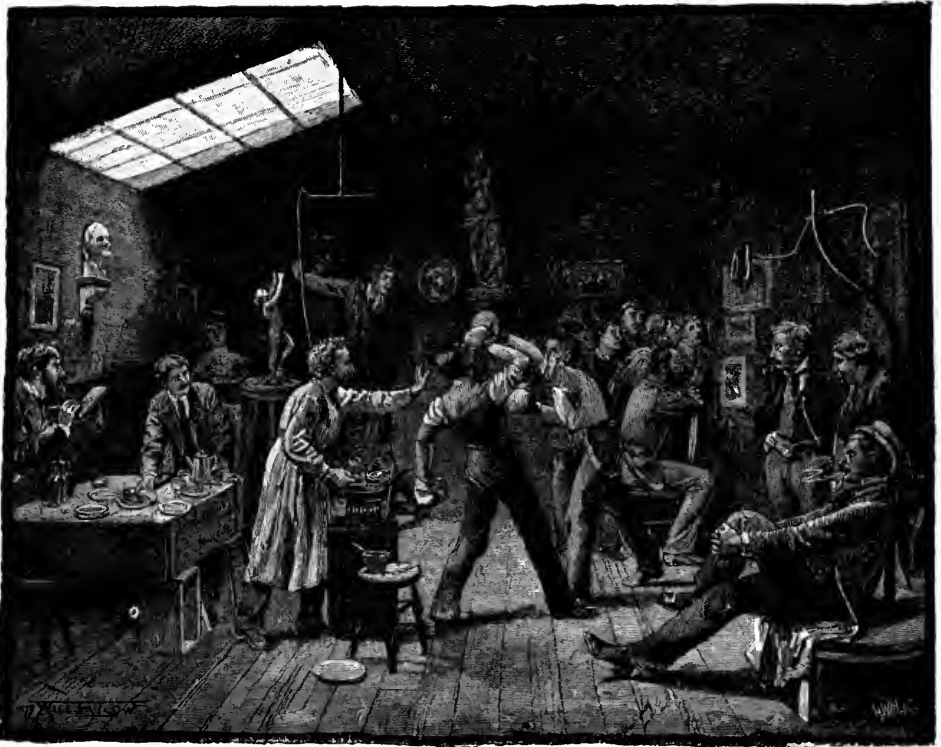

THE SALMAGUNDI CLUB IN EARLY TIMES. (DRAWN BY WILL H. LOW.)

of color and an irregularity of outline with which neither London nor Paris can compare; for New York has made more of the arrangements for purely modern life than any other city in the world. Brow-beaten as the student naturally is by the traditional American reverence for foreign parts, perhaps it would not be fair to expect the discovery from this source. It is rather from the returned proficients, who have seen and know, that it is to be looked for.

These new-comers, mustering now in large force and strengthened by constant arrivals, must be counted the most prominent element in the artist life of the city. It is not only in the schools, where they occupy the professorships and control the coming generation, but in all the movements, formal and informal, without. The older men of the Academy are no longer an active social factor of artist life. Ten years ago a long tableful of them, with Page at the head, was still dining at an Italian restaurant in Third avenue, whither they resorted for the speech and cheap wine that gave them reminis-

cences of their days of travel in diligences across complicated frontiers. The restaurant-keeper prospered, and has arrived at imposing brown-stone elegance; but long before this they ceased to follow him. The Palette Club, an association of artists and laymen which comprised many of the older men and became possessed of a handsome clubhouse, has also declined as a place of artistic resort, and is now said to contain laymen only.

A similar tableful of artists dines together to-day, but it is made up entirely of the young men of the new movement. They are graduates of Paris and Munich, and are the main supporters of the new "American Art Association." They have lived long enough in Europe to see something of its commonplace side, and are content to discuss it chiefly from the point of view of its comparative practical advantages. They are not led by sentimental considerations to a French or German place, but choose a comfortable American restaurant. Their talk, when it is not jocose, is of a practical character by preference. They discuss technical

points, the manner of this and that artist, new methods of laying paint with a palette knife instead of brush, and the disproportion in this country of the artist's expenses to his returns. The newest arrival complains that he finds \$400 and \$600 the ruling rates for studios, while he could have had the best in Munich for less than \$200. On the whole, they are a superior group of fellows

admission, has been formed by a group of the strongest men. It holds its meetings for the present in an upper room of a *restaurant*, whose keeper has some natural taste for pictures, and calls his place by the appropriate title of "The Studio." In its newest infancy yet, the society looks forward to permanent quarters, and in time to a building of its own, which it shall decorate and fill



A MODERN MEETING OF THE SALMAGUNDI CLUB. (DRAWN BY H. P. SHARE.)

as they sit around their long table, with good heads, capable of thought on a higher order of matters as well. Some current circumstance, one of the conflicting newspaper articles on their recent doings, turns the talk with a pleasant animation to theory and original speculation. Their position as pioneers in a new period of art development, and the prospective results, are touched upon. The American subject, the simple, the nude, the historical in art, such a one's new propositions in perspective, all come in for a share of attention with the coffee and cigars. A new Art Club to which a certain standard of ability is made a condition of

with a collection of costumes and rich properties after the style of the agreeable "Paint-Box" (the Malkasten) of Düsseldorf.

It is agreeable to note how reconciled the returned art students are on the whole, with a considerable touch of surprise, to what they find in this country. They were birds of passage in spirit, as any one may know who has attended at all to the manner of their departure. They said farewell to Europe with the air of the performance of a disagreeable duty, and scarcely made it a secret that they should be back again, if things were not very much to their liking. But they find a congenial circle,

a general appreciation of them and their work, employment and a prospect of fair rewards for those who may be thought by a fair construction worthy of them. Since they went away, household art has invaded every furniture shop and there is a curiosity shop in nearly every street. There are plenty of the best modern pictures in the new world, and not a few excellent old ones. They discover with delight a magnificent Velasquez at the rooms of the Historical Society, and at the Metropolitan Museum a Franz Hals not surpassed in all Europe. Moreover, during winter and spring four important exhibitions follow one another in immediate succession. They make charming places of their studios in Tenth street or the Christian Association building, bestowing in them their tapestries and carved chests, which have an added preciousness in their new situation. If

place for the location of his romance of "Cecil Dreeme." The chapel has been divided by a floor at half its height, and this again by a few partitions. In the spacious upper chambers thus formed, which command picturesque views of Washington Square, the Hudson River and the New Jersey hills beyond, the ribs and pendentives of the vaulted roof still show, with a most ancient and baronial effect.

Scattered irregularly throughout the town are the studios of the beginners,—and of many who began long enough ago, heaven knows,—a great obscure body, full of aspiration, recognized failures and whimsical vicissitudes of fortune, between the student class and that of established reputation. Penetrating through the yard of an ordinary house in Fourth street, one encounters Michael Angelo's "Moses," and finds sculptors upstairs in an out-building. Others occupy a

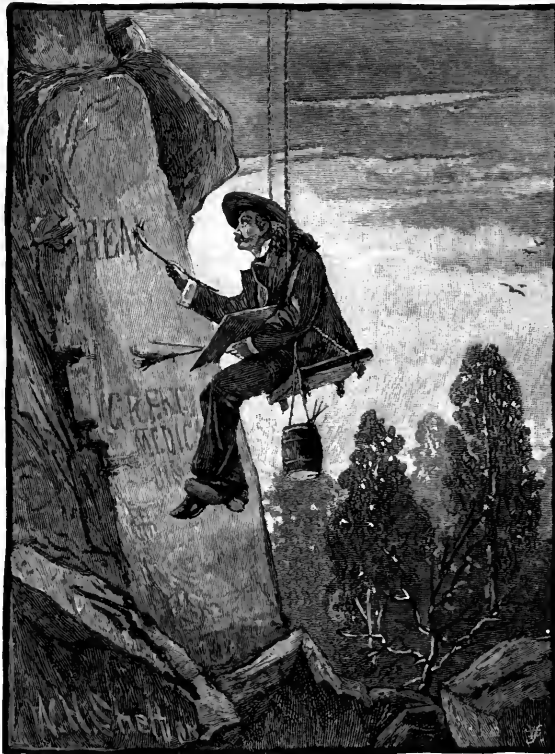

AN ARTIST IN ROCKS. (DRAWN BY W. H. SHELTON.)

something odd in the way of a studio be demanded, it may be found in the old-fashioned Tudor pile known as the University building, more singular now than when Winthrop found it an appropriate

loft over a frame-maker's. Three others are in a cheap flat with a work-room in common. Another uses the parlor of the flat occupied by his indulgent family, in an uptown street, and keeps his mother and a small

servant-maid posing while the household matters wait.

For the most part, however, the studios are on Broadway. Few of the older business

night on trestles. Coffee is drunk from a tomato can. A chop or steak is cooked by lowering it down with a wire through the top of an ordinary cylinder stove. The

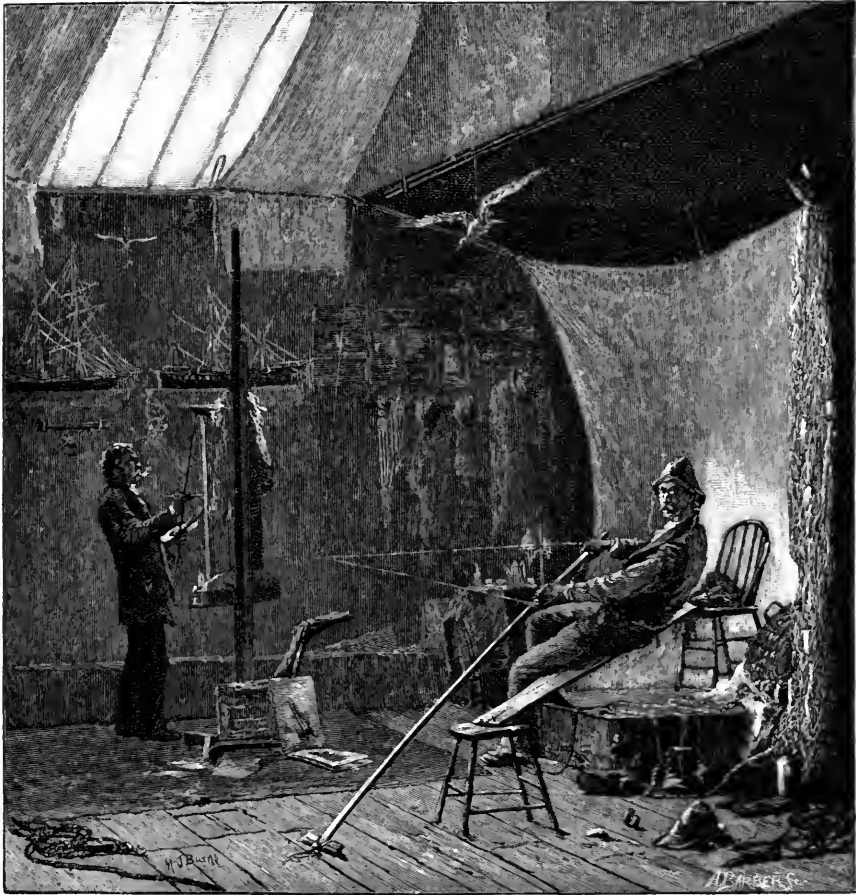

A MARINE ARTIST'S STUDIO. (DRAWN BY M. J. BURNS.)

buildings of the great thoroughfare from Houston street up but would yield to the search some obscure door in the upper regions bearing the title Artist. They are often the dingy quarters, with splintered, acid-stained floors, abandoned by photographers. There are rarely side windows, and the sole view is of the sky. The studio of the poorer class is sleeping room, and generally more or less kitchen as well. Disregard of conventional forms sometimes reaches the point of actual squalor. Here in one costing fifteen dollars a month, three persons are sleeping, two on a lounge—which also serves as a coal box—and one on a shelf conveniently placed at

collection of dust-covered clothing, old boots and shoes, withered ferns, half dry sketches, plaster busts, groceries, books, and oil-cans, presided over by a battered lay figure in a Roman toga and slouch hat, would do little violence to the ideal of symmetry in a rag and bottle shop. It is a veritable *vie de Bohème* that goes on. Such a fellow is said to have reduced to a nicety the art of renovating a linen front with Chinese white instead of sending it to the laundry. Landlords are regarded in an odious light, and if possible locked out. One, who would be put off no longer, was paid his rent in busts of Evangeline, which even the amiable Longfellow had

repudiated. Pictures are made a medium of exchange with the butcher and the tailor. If fortune be propitious the bohemian luxuriates at boarding-houses and restaurants, whose walls he becomingly adorns. At other times he takes but a single meal or only mush and milk. There are boasts to be heard of having lived on two dollars and even one dollar a week in times much more expensive than the present. Such straits are often the result of an aversion to regular labor, or of such an improvidence that it amounts to choice. The proceeds of an important commission may be spent in a preliminary dinner of rejoicing and another of thanksgiving at its completion before they are received. But often enough the pinching is a genuine necessity. An artist of known standing, proud and unable to turn with facility in new directions, found himself reduced by the failure of the Sixpenny Savings Bank during the absence of his friends in the country, to a summer of scarcely more than bread and water. Then there are the strangers from the west and south, friendless, large-bearded Germans newly arrived in the country, and the tribe of incapables, persisting in this art against the most glaring evidence of incapacity,—pathetic martyrs to mediocrity.

The range of expedients for subsistence during the time the great projects which are to bring fame and fortune are matured is widely varied. Illustration takes the first place. It is more easy of access than formerly, when drawing on wood must be done in a formal way and was a kind of



AN ANIMAL ARTIST'S STUDIO. (DRAWN BY J. E. KELLY.)

trade in itself. On the other hand the standard of performance has greatly advanced, and those who are able to meet the enlightened taste of the time are already on the high road to everything desirable. By a kind of anomaly it is the testimony of publishers that more wretched comic cuts are sent in by the distressed class than anything else. The weekly story papers are one resource. There are those again who debase excellent talents, on the pitiful plea that some other will if they do not, to the service of the licentious flash journals. In another line, "real oil portraits" have been offered in the Bowery for \$10. The crayon portrait was long a standing resource for keeping struggling artists alive, but the market is said to be much broken of late. An enterprising fellow carries on his campaign by making tours in the country, lettering rocks and fences with patent medicine advertisements. Another, "the black-eye artist," has developed a novel industry, especially lucrative about election times, in giving an innocent and normal appearance to faces damaged in rough-and-tumble encounters.

To the "shanghai," however, must be assigned the place of honor among the makeshifts of an impecunious, commonplace, and not very conscientious class of



"DECAY." (BASS-RELIEF SKETCH IN CLAY BY WALTER CLARK.)

artists. The "shanghai" is the glaring daub required by some frame-makers for cheap auctions. They are turned out at so much by the day's labor, or at from \$12 to \$24 a dozen, by the piece. All the skies

do?" or "How would that do?" Obligated to return at last unsuccessful, he smeared out the sketches with his elbow and grumbled roundly at such a case of disgusting obduracy. -

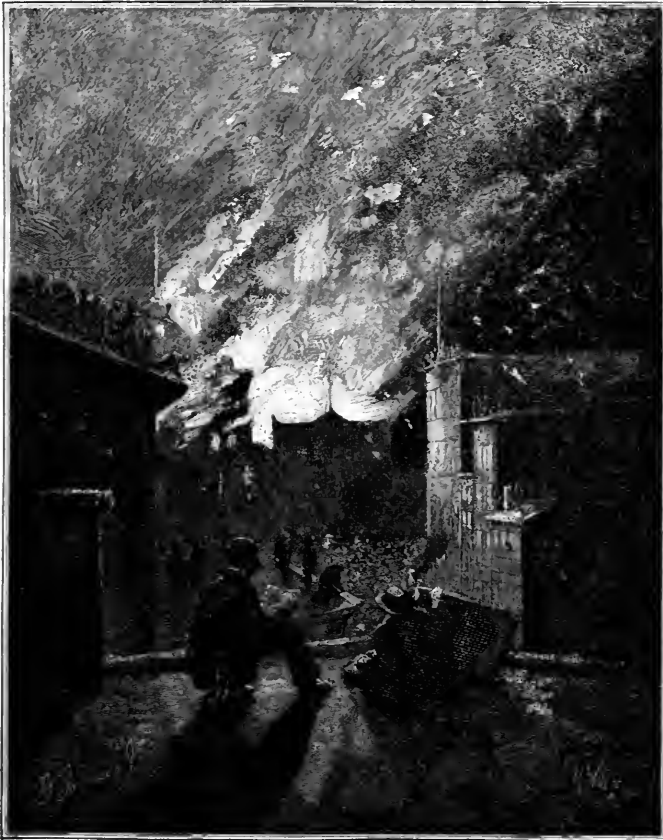

THE ILLUSTRATOR ILLUSTRATED. (DRAWN BY GEORGE INNESS, JR.)

are painted at once, then all the foregrounds. Sometimes the patterns are stenciled. The dealer attaches the semblance of some well-known name, of which there are several, and without initials. The sonorous auctioneer cries aloud: "This work of art is an original of Kenstett, gentlemen, and now can I believe my ears that I am offered but a hundred dollars for it?"

Among this impecunious class, the proper bearing to be observed toward the patron, the desirability of social and commercial arts for advancement, are frequent subjects of thought. It is told of one that he followed a half-would-be purchaser down four flights of stairs, arguing all the way. At every few steps he paused to make charcoal sketches on the wall, saying: "How would this

The relations with the model class would furnish an interesting chapter in itself. The want which was long the chief drawback of American artists is now fairly supplied. Prices are no longer exorbitant. There are attempts, nevertheless, to secure material out of the regular routine, and, by the impecunious, at the lowest plausible rates. In these excursions novel and humorous experiences are encountered. Orphan asylums and old ladies' homes are visited for pleasing heads. A Crosby street tenement house furnishes available Italians. The chance subject is often alarmed, and finds it difficult to understand the purpose in hand. "Is it paint me yer after?" said a brawny laborer from the street-cleaning department; "and would it come off, I dunno?"

It ought to be rather better known that there is no other city where the woman student can pursue advanced studies in art with so few embarrassments as in New York. She certainly cannot in the very different social customs prevailing at Paris and Munich, or in the murky gloom of the Slade and South Kensington schools of London, where four or five hours of daylight in the winter is the maximum allowance. Here, too, studio life for women has come to be a somewhat recognized mode of existence. It is understood now by the landlord, the butcher, the baker, and the milkman. There are usually two inmates, for protection and companionship; but the erection of a suitable studio building for women artists would be a genuine and amiable field for philanthropy. It should have ample household

she maintains that the only difference between her domestic economy and that of the world at large is that she washes her dishes after dark. Everything is neat and compact as in the cabin of a ship. I have no idea that the one my lodging gives me an opportunity of observing at a distance, decorating Egyptian vases in a dim interior, and sometimes coming to the window to water a box of geraniums, would like to be thought of as a Hilda. Her residence is in one of the most formal and decorous of the up-town buildings suitable for the purpose; and it is fire-proof shutters on a court she throws open in the morning, instead of coming to feed circling white doves from a battlemented tower.

A peculiar line of characters appear in the studios of the lady artist. She is apt to

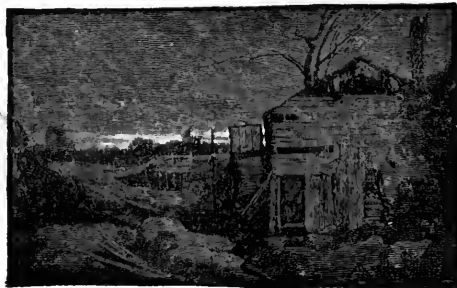
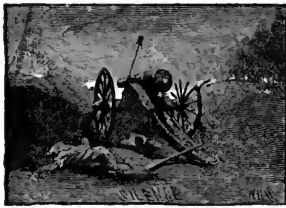

"SILENCE": STUDIES BY MEMBERS OF THE SALMAGUNDI.

conveniences, for nobody is less bohemian in her own feelings than the woman artist. She has nothing in common with the disorder of her masculine *confrère*. She keeps house, it is true, in a small compass; but

be more infested by bores, from the book-agent to the idle visitor, than a man, because they are less afraid of her. The expressman and the emissaries who bring provisions have more or less of a patronizing air. A

sign-painter who lettered the door of one made a discount in the bill in consideration of fellowship in "the profession." One well-known visitor is a hard-featured, most respectable old lady, who makes it her pride that she washes only for art and the church. It is apparent that she secretly looks upon her own profession as superior to either; yet she sometimes consents to serve as a model.

An association for mutual aid and comfort, known as the Woman's Art Society, numbers sixty members. It has been the occasion of the relief of many cases of obscure and painful hardship. The woman artist has her full share of trials in the beginning also. Prosaic advertisers bring orders for designs for the Eugenia skirt or Centennial blacking, instead of commissions for high art. The popular taste has much increased the demand for decorated fans, lamp-shades, patterns for embroidery, and tiles for furniture. At the same time a great influx of new-comers and the enterprise of amateurs working for pocket-money, leaves less of a resource in this direction than might be imagined.

In 1872 a knot of rather the most irregular young fellows of the irregular kind described was in the habit of gathering at the studio of a *confrère*, now a successful sculptor. He did his own cooking, like the others, but it was genuine cooking. It reached lofty flights of soups and oyster-pie undreamed of by the rest. Neither improvident nor niggardly, he had something like a tangible hospitality regularly to offer. Once a dance was given at which a paid fiddler was employed. A sort of sketch class was formed in time which brought in all kinds of random subjects from the street. Some minor actors and newspaper men who had come once were pleased to return again to the evening assemblies. Fencing and boxing went on in one corner and declaiming in another, while the fine arts pursued their way as best they could.

The five original members increased to twenty. The plan first adopted is still pursued: designs are prepared on a given subject and brought down to a meeting each week for display and criticism.

The boisterous early surroundings were adverse, however, and after the first year, upon the departure for Europe of some of

the leading spirits, the club suspended. Three years ago, several of these having returned, it was reorganized on a much more serious basis, and became the Salmagundi club, brought favorably into public notice by its recent "Black and White" exhibitions. It has gathered in now some thirty members, and includes an array of talent of no common order. The work shows a vast improvement over that of the early period, yet so great is the range of subject for which illustration is required by the increasing demand, that it will be long before the occupation of the club is gone.

The Salmagundi convenes at nine of Friday nights at the studio of a young marine painter in Astor Place. The appurtenances are somewhat dingy, and there is a mellow atmosphere of smoke in the room. A long table, spread with a white cloth and having shining pots of chocolate and coffee upon it, makes a cheerful high light in the center. A mixture of the two, the Italian *mischio*, has been adopted as a happy solution of



"SILENCE." (BASS-RELIEF SKETCH IN CLAY BY J. LAUBER.)

the refreshment problem. The pots are the peculiar emblem of the club.

The members are gathered from occupations, each of which would furnish an entertaining special study. The marine painter has lately been daring shipwreck on the



"SILENCE." (BASS-RELIEF IN CLAY BY J. S. HARTLEY.)

coast of Labrador, and his room is full of trophies of the sea. The specialty of this one is animals in quiet pastures; of that, men and animals in violent action. The latter keeps a bull-dog to worry the garments used in his military pieces into semblance of having passed through a campaign. He resorts to stable-yards to perfect the details of the motion he has first noticed in the street or the park. The illustrated paper artist is there, too. His is a career of universal adventure. He takes down the leading points of a fire at night, with the end walls tumbling uncomfortably near him. He is waist-deep in snow at the Port Jervis ice-gorge, or in water at the Mill River disaster. There are labor-saving inventions to help him, but this merely increases the scale of his rapidity. It is necessary now that the cut of the boat-race or the inauguration ceremonies should be on the news-stands the day the event occurs. By an occasional inadvertence it is there the day before!

With such experiences to draw from, it would seem that the designs need not lack variety. The easy traditions of the past are continued in an absence of formality in the proceedings. Red-tapeism is made odious. Public sentiment was at one time opposed to a president, a constitution, or even a title. The official business consists merely in balloting for the choice of the next week's subject. Suggestions are handed in and

recorded on a list, which the chairman reads as a preliminary. "Yes or No," "Spring," "Idolatry," "Silence," "Blood," "Home-ward-Bound," give an idea of their character and scope. "The Lay of the Forsaken Heart," attributed to a diffident member, has long been passed without adoption, and is now cursorily disposed of as "the Lay." A member with an especial *penchant* for horrors is distinguished as "Calamity"

The submitted designs, tacked upon the wall, are turned to with a lively attention. The remaining possibilities in the theme, after each has drawn from it what seemed to him its most striking aspect, are a matter of general curiosity and an enlarging experience on each occasion. The sketches are of all shapes and sizes. Careful finish is not a requirement, the conception being the important thing. They are done in chalk and charcoal, distemper, oil, pencil, India ink, pen and ink, any and every material, but not often in colors. Among the most interesting is the manner in which the ideas of the sculptor first take form. On another evening of the week the designs are placed before the Art Students' League, for a formal exposition by a professor of the principles of design exhibited in them. With all this the once happy-go-lucky Salmagundi Club may well flatter itself on having become one of the most improving agencies in the whole artistic community.

THE GRANDISSIMES.*

A STORY OF CREOLE LIFE.

By GEORGE W. CABLE, author of "Old Creole Days."

CHAPTER XIV.

BEFORE SUNSET.

IN old times, most of the sidewalks of New Orleans not in the heart of town were only a rough, rank turf, lined on the side next the ditch with the gunwales of broken-up flat-boats—ugly, narrow, slippery objects. As Aurora—it sounds so much pleasanter to anglicize her name—as Aurora gained a corner where two of these gunwales met, she stopped and looked back to make sure that Clotilde was not watching her. That others had noticed her here and there she did not care; that was something beauty would have to endure, and it only made her smile to herself.

"Everybody sees I am from the country—walking on the street without a waiting-maid."

A boy passed, hushing his whistle, and gazing at the lone lady until his turning neck would twist no farther. She was so dewy fresh! After he had got across the street he turned to look again. Where could she have disappeared?

The only object to be seen on the corner from which she had vanished, was a small, yellow-washed house much like the one Aurora occupied, as it was like hundreds that then characterized and still characterize the town, only that now they are of brick instead of adobe. They showed in those days, even more than now, the wide contrast between their homely exteriors and the often elegant apartments within. However, in this house the front room was merely neat. The furniture was of rude, heavy pattern, Creole-made, and the walls were unadorned; the day of cheap pictures had not come. The lofty bedstead which filled one corner was spread and hung with a blue stuff showing through a web of white needlework. The brazen feet of the chairs were brightly burnished, as were the brass mountings of the bedstead and the brass globes on the cold andirons. Curtains of blue and white hung at the single window. The floor, from habitual scrubbing with the common weed which politeness has to call

Helenium autumnale, was stained a bright, clean yellow. On it were here and there in places, white mats woven of bleached palmetto-leaf. Such were the room's appointments; there was but one thing more,—a singular bit of fantastic carving,—a small table of dark mahogany supported on the upward-writhing images of three scaly serpents.

Aurora sat down beside this table. A dwarf Congo woman, as black as soot, had ushered her in, and, having barred the door, had disappeared, and now the mistress of the house entered.

February as it was, she was dressed—and looked comfortable—in white. That barbaric beauty which had begun to bud twenty years before was now in perfect bloom. The united grace and pride of her movement was inspiring but—what shall we say?—feline? It was a femininity without humanity,—something that made her, with all her superbness, a creature that one would want to find chained. It was the woman who had received the gold from Frowenfeld—Palmyre Philosophe.

The moment her eyes fell upon Aurora her whole appearance changed. A girlish smile lighted up her face, and as Aurora rose up reflecting it back, they simultaneously clapped hands, laughed and advanced joyously toward each other, talking rapidly without regard to each other's words.

"Sit down," said Palmyre, in the plantation French of their childhood, as they shook hands.

They took chairs and drew up face to face as close as they could come, then sighed and smiled a moment, and then looked grave and were silent. For in the nature of things, and notwithstanding the amusing familiarity common between Creole ladies and their domestics, the unprotected little widow should have had a very serious errand to bring her to the voodoo's house.

"Palmyre," began the lady, in a sad tone.

"Momselle Aurore."

"I want you to help me." The former

mistress not only cast her hands into her lap, lifted her eyes supplicatingly and dropped them again, but actually locked her fingers to keep them from trembling.

"Momselle Aurore——" began Palmyre, solemly.

"Now, I know what you are going to say—but it is of no use to say it; do this much for me this one time and then I will let voodoo alone as much as you wish—forever!"

"You have not lost your purse *again*?"

"Ah! foolishness, no."

Both laughed a little, the philosophe feebly and Aurora with an excited tremor.

"Well?" demanded the quadroon, looking grave again.

Aurora did not answer.

"Do you wish me to work a spell for you?"

The widow nodded, with her eyes cast down.

Both sat quite still for some time; then the philosophe gently drew the landlord's letter from between Aurora's hands.

"What is this?" She could not read in any language.

"I must pay my rent within nineteen days."

"Have you not paid it?"

The delinquent shook her head.

"Where is the gold that came into your purse? All gone?"

"For rice and potatoes," said Aurora, and for the first time she uttered a genuine laugh, under that condition of mind which Latins usually substitute for fortitude. Palmyre laughed too, very properly.

Another silence followed. The lady could not return the quadroon's searching gaze.

"Momselle Aurore," suddenly said Palmyre, "you want me to work a spell for something else."

Aurora started, looked up for an instant in a frightened way, and then dropped her eyes and let her head droop, murmuring:

"No, I do not."

Palmyre fixed a long look upon her former mistress. She saw that though Aurora might be distressed about the rent, there was something else,—a deeper feeling, impelling her upon a course the very thought of which drove the color from her lips and made her tremble.

"You are wearing red," said the philosophe.

Aurora's hand went nervously to the red ribbon about her neck.

"It is an accident; I had nothing else convenient."

"Miché Agoussou loves red," persisted Palmyre. (Monsieur Agoussou is the demon upon whom the voodous call in matters of love.)

The color that came into Aurora's cheek ought to have suited Monsieur precisely.

"It is an accident," she feebly insisted.

"Well," presently said Palmyre, with a pretense of abandoning her impression, "then you want me to work you a spell for money, do you?"

Aurora nodded, while she still avoided the quadroon's glance.

"I know better," thought the philosophe. "You shall have the sort you want."

The widow stole an upward glance.

"Oh!" said Palmyre, with the manner of one making a decided digression, "I have been wanting to ask you something. That evening at the pharmacy—was there a tall handsome gentleman standing by the counter?"

"He was standing on the other side."

"Did you see his face?"

"No; his back was turned."

"Momselle Aurore," said Palmyre, dropping her elbows upon her knees and taking the lady's hand as if the better to secure the truth, "was that the gentleman you met at the ball?"

"My faith!" said Aurora, stretching her eyebrows upward. "I did not think to look. Who was it?"

But Palmyre Philosophe was not going to give more than she got, even to her old-time Momselle; she merely straightened back into her chair with an amiable face.

"Who do you think he is?" persisted Aurora, after a pause, smiling downward and toying with her rings.

The quadroon shrugged.

They both sat in reverie for a moment—a long moment for such sprightly natures—and Palmyre's mien took on a professional gravity. She presently pushed the landlord's letter under the lady's hands as they lay clasped in her lap, and a moment after drew Aurora's glance with her large, strong eyes and asked:

"What shall we do?"

The lady immediately looked startled and alarmed and again dropped her eyes in silence. The quadroon had to speak again.

"We will burn a candle."

Aurora trembled.

"No," she succeeded in saying.

"Yes," said Palmyre, "you must get your rent money." But the charm which she

was meditating had no reference to rent money. "She knows that," thought the voodoo.

As she rose and called her Congo slave-woman, Aurora made as if to protest further; but utterance failed her. She clenched her hands and prayed to Fate for Clotilde to come and lead her away as she had done at the apothecary's. And well she might.

The articles brought in by the servant were simply a little pound-cake and cordial, a tumbler half filled with the *sirup naturelle* of the sugar-cane, and a small piece of candle of the kind made from the fragrant green wax of the candleberry myrtle. These were set upon the small table, the bit of candle standing, lighted, in the tumbler of sirup, the cake on a plate, the cordial in a wine-glass. This feeble child's play was all; except that as Palmyre closed out all daylight from the room and received the offering of silver that "paid the floor" and averted *guillons* (interferences of outside imps), Aurora,—alas! alas!—went down upon her knees with her gaze fixed upon the candle's flame, and silently called on Assonquer (the imp of good fortune) to cast his snare in her behalf around the mind and heart of—she knew not whom.

By and by her lips, which had moved at first, were still and she only watched the burning wax. When the flame rose clear and long it was a sign that Assonquer was enlisted in the coveted endeavor. When the wick sputtered, the devotee trembled in fear of failure. Its charred end curled down and twisted away from her and her heart sank; but the tall figure of Palmyre for a moment came between, the wick was snuffed, the flame tapered up again and for a long time burned a bright, tremulous cone. Again the wick turned down, but this time toward her,—a propitious omen,—and suddenly fell through the expended wax and went out in the sirup.

The daylight, as Palmyre let it once more into the apartment, showed Aurora sadly agitated. In evidence of the innocence of her fluttering heart, guilt, at least for the moment, lay on it, an appalling burden.

"That is all, Palmyre, is it not? I am sure that is all—it must be all. I cannot stay any longer. I wish I was with Clotilde; I have staid too long."

"Yes; all for the present," replied the quadroon. "Here, here is some charmed basil; hold it between your lips as you walk——"

"But I am going to my landlord's office!"

"Office? Nobody is at his office now; it is too late. You would find that your landlord had gone to dinner. I will tell you, though, where you *must* go. First go home; eat your dinner; and this evening [the Creoles never say afternoon], about a half-hour before sunset, walk down Royale to the lower corner of the Place d'Armes, pass entirely around the square and return up Royale. Never look behind until you get into your house again."

Aurora blushed with shame.

"Alone?" she exclaimed, quite unnerved and tremulous.

"You will seem to be alone; but I will follow behind you when you pass here. Nothing shall hurt you. If you do that, the charm will certainly work; if you do not——"

The quadroon's intentions were good. She was determined to see who it was that could so infatuate her dear little Momselle; and, as on such an evening as the present afternoon promised to merge into, all New Orleans promenaded on the Place d'Armes and the levee, her charm was a very practical one.

"And that will bring the money, will it?" asked Aurora.

"It will bring anything you want."

"Possible?"

"These things that *you* want, Momselle Aurore, are easy to bring. You have no charms working against you. But, oh! I wish to God I could work the *curse* I want to work!" The woman's eyes blazed, her bosom heaved, she lifted her clenched hand above her head and looked upward, crying: "I would give this right hand off at the wrist to catch Agricola Fusilier where I could work him a curse! But I shall; I shall some day be revenged!" She pitched her voice still higher. "I cannot die till I have been! There is nothing that could kill me, I want my revenge so bad!" As suddenly as she had broken out, she hushed, unbarred the door, and with a stern farewell smile saw Aurora turn homeward.

"Give me something to eat, *chérie*," cried the exhausted lady, dropping into Clotilde's chair and trying to die.

"Ah! *maman*, what makes you look so sick?"

Aurora waved her hand contemptuously and gasped.

"Did you see him? What kept you so long—so long?"

"Ask me nothing; I am so enraged with disappointment. He was gone to dinner!"

"Ah! my poor mother!"

"And I must go back as soon as I can take a little *sieste*. I am determined to see him this very day."

"Ah! my poor mother!"

CHAPTER XV.

ROLLED IN THE DUST.

"No, Frowenfeld," said little Doctor Keene, speaking for the after-dinner loungers, "you must take a little human advice. Go, get the air on the Plaza. We will keep shop for you. Stay as long as you like and come home in any condition you think best." And Joseph, tormented into this course, put on his hat and went out.

"Hard to move as a cow in the moonlight," continued Doctor Keene, "and knows just about as much of the world. He wasn't aware, until I told him to-day, that there are two Honoré Grandissimes." [Laughter.]

"Why did you tell him?"

"I didn't give him anything but the bare fact. I want to see how long it will take him to find out the rest."

The Place d'Armes offered amusement to every one else rather than to the immigrant. The family relation, the most noticeable feature of its well-pleased groups, was to him too painful a reminder of his late losses, and, after an honest endeavor to flutter out of the inner twilight of himself into the outer glare of a moving world, he had given up the effort and had passed beyond the square and seated himself upon a rude bench which encircled the trunk of a willow on the levee.

The negress, who, resting near by with a tray of cakes before her, has been for some time contemplating the three-quarter face of her unconscious neighbor, drops her head at last with a small, Ethiopian, feminine laugh. It is a self-confession that, pleasant as the study of his countenance is, to resolve that study into knowledge is beyond her powers; and very pardonably so it is, she being but a *marchande des gâteaux* (an itinerant cake-vender) and he, she concludes, a man of parts. There is a purpose, too, as well as an admission, in the laugh. She would like to engage him in conversation. But he does not notice. Little supposing he is the object of even a cake-merchant's attention, he is lost in idle meditation.

One would guess his age to be as much

as twenty-six. His face is beardless, of course, like almost everybody's around him, and of a German kind of seriousness. A certain diffidence in his look may tend to render him unattractive to careless eyes, the more so since he has a slight appearance of self-neglect. On a second glance, his refinement shows out more distinctly, and one also sees that he is not shabby. The little that seems lacking is woman's care, the brush of attentive fingers here and there, the turning of a fold in the high-colored coat, and a mere touch on the neckerchief and shirt-frill. He has a decidedly good forehead. His blue eyes, while they are both strong and modest, are noticeable, too, as betraying fatigue, and the shade of gravity in them is deepened by a certain worn look of excess—in books; a most unusual look in New Orleans in those days, and pointedly out of keeping with the scene which was absorbing his attention.

You might mistake the time for mid-May. Before the view lies the Place d'Armes in its green-breasted uniform of new spring grass crossed diagonally with white shell walks for facings, and dotted with the *élite* of the city for decorations. Over the line of shade-trees which marks its farther boundary, the white-topped twin turrets of St. Louis Cathedral look across it and beyond the bared site of the removed battery (built by the busy Carondelet to protect Louisiana from herself and Kentucky, and razed by his immediate successors) and out upon the Mississippi, the color of whose surface is beginning to change with the changing sky of this beautiful and now departing day. A breeze, which is almost early June, and which has been hovering over the bosom of the great river and above the turf-covered levee, ceases, as if it sank exhausted under its burden of spring odors, and in the profound calm the cathedral bell strikes the sunset hour. From its neighboring garden, the convent of the Ursulines responds in a tone of devoutness, while from the parapet of the less pious little Fort St. Charles, the evening gun sends a solemn ejaculation rumbling down the "coast"; a drum rolls, the air rises again from the water like a flock of birds, and many in the square and on the levee's crown turn and accept its gentle blowing. Rising over the levee willows, and sinking into the streets,—which are lower than the water,—it flutters among the balconies and in and out of dim Spanish arcades, and finally drifts away toward that part of the sky

where the sun is sinking behind the low, unbroken line of forest. There is such subduction in the evening air, such sweetness of flowers on its every motion, such lack of cold, or heat, or dust, or wet, that the people have no heart to stay in-doors; nor is there any reason why they should. The levee road is dotted with horsemen, and the willow avenue on the levee's crown, the whole short mile between Terre aux Bœufs gate on the right and Tchoupitoulas gate on the left, is bright with promenaders, although the hour is brief and there will be no twilight; for, so far from being May, it is merely that same nineteenth of which we have already spoken,—the nineteenth of Louisiana's delicious February.

Among the throng were many whose names were going to be written large in history. There was Casa Calvo,—Sebastian de Casa Calvo de la Puerta y O'Farril, Marquis of Casa Calvo,—a man then at the fine age of fifty-three, elegant, fascinating, perfect in Spanish courtesy and Spanish diplomacy, rolling by in a showy equipage surrounded by a clanking body-guard of the Catholic king's cavalry. There was young Daniel Clark, already beginning to amass those riches which an age of litigation has not to this day consumed; it was he whom the French colonial prefect, Laussat, in a late letter to France, had extolled as a man whose "talents for intrigue were carried to a rare degree of excellence." There was Laussat himself, in the flower of his years, sour with pride, conscious of great official insignificance and full of petty spites—he yet tarried in a land where his beautiful wife was the "model of taste." There was that convivial old fox, Wilkinson, who had plotted for years with Miro and did not sell himself and his country to Spain because—as we now say—"he found he could do better;" who modestly confessed himself in a traitor's letter to the Spanish king as a man "whose head may err, but whose heart cannot deceive!" and who brought Governor Gayoso to an early death-bed by simply outdrinking him. There also was Edward Livingston, attorney-at-law, inseparably joined to the mention of the famous Batture cases—though that was later. There also was that terror of colonial speculators, the old Ex-Intendant Morales, who, having quarreled with every governor of Louisiana he ever saw, was now snarling at Casa Calvo from force of habit.

And the Creoles—the Knickerbockers of Louisiana—but time would fail us. The

Villeres and Destrehaus—patriots and patriots' sons; the De la Chaise family in mourning for young Auguste La Chaise of Kentuckian-Louisianian-San Domingan history; the Livadaises, *père et fils*, of Haunted House fame, descendants of the first pilot of the Belize; the pirate brothers Lafitte, moving among the best; Marigny de Mandeville, afterward the marquis member of Congress; the Davezacs, the Mossys, the Boulognys, the Labatuts, the Bringiers, the De Trudeaus, the De Macartys, the De la Houssayes, the De Lavillebœuvres, the Grandprés, the Forstalls; and the proselyted Creoles: Etienne de Boré (he was the father of all such as handle the sugar-kettle); old man Pétot, who became mayor; Madame Pontalba and her unsuccessful suitor, John McDonough; the three Girods, the two Gravieres, or the lone Julian Poydras, godfather of orphan girls. Besides these, and among them as shining fractions of the community, the numerous representatives of the not only noble, but noticeable and ubiquitous, family of Grandissime: Grandissimes simple and Grandissimes compound; Brahmins, Mandarins and Fusiliers. One, Polyte by name, a light, gay fellow, with classic features, hair turning gray, is standing and conversing with this group here by the mock-cannon inclosure of the grounds. Another, his cousin, Charlie Mandarin, a tall, very slender, bronzed gentleman in a flannel hunting-shirt and buckskin leggings, is walking, in moccasins, with a sweet lady in whose tasteful attire feminine scrutiny, but such only, might detect economy, but whose marked beauty of yesterday is retreating and re-appearing in the flock of children who are noisily running round and round them, nominally in the care of three fat and venerable black nurses. Another, yonder, Théophile Grandissime, is whipping his stockings with his cané, a lithe youngster in the height of the fashion (be it understood the fashion in New Orleans was five years or so behind Paris), with a joyous, noble face, a merry tongue and giddy laugh, and a confession of experiences which these pages, fortunately for their moral tone, need not recount. All these were there and many others.

This throng, shifting like the fragments of colored glass in the kaleidoscope, had its far-away interest to the contemplative Joseph. To them he was of little interest, or none. Of the many passers, scarcely an occasional one greeted him, and such only with an extremely polite and silent dignity which seemed to him like saying something

of this sort: "Most noble alien, give you good-day—stay where you are. Profoundly yours——"

Two men came through the Place d'Armes on conspicuously fine horses. One it is not necessary to describe. The other, a man of perhaps thirty-three or thirty-four years of age, was extremely handsome and well dressed, the martial fashion of the day showing his tall and finely knit figure to much advantage. He sat his horse with an uncommon grace, and, as he rode beside his companion, spoke and gave ear by turns with an easy dignity sufficient of itself to have attracted popular observation. It was the apothecary's unknown friend. Frowenfeld noticed them while they were yet in the middle of the grounds. He could hardly have failed to do so, for some one close beside his bench in undoubted allusion to one of the approaching figures exclaimed:

"Here comes Honoré Grandissime."

Moreover, at that moment there was a slight unwonted stir on the Place d'Armes. It began at the farther corner of the square, hard by the Principal, and spread so quickly through the groups near about, that in a minute the entire company were quietly made aware of something going notably wrong in their immediate presence. There was no running to see it. There seemed to be not so much as any verbal communication of the matter from mouth to mouth. Rather a consciousness appeared to catch noiselessly from one to another as the knowledge of human intrusion comes to groups of deer in a park. There was the same elevating of the head here and there, the same rounding of beautiful eyes. Some stared, others slowly approached, while others turned and moved away; but a common indignation was in the breast of that thing dreadful everywhere, but terrible in Louisiana, the Majority. For there, in the presence of those good citizens, before the eyes of the proudest and fairest mothers and daughters of New Orleans, glaringly, on the open Plaza, the Creole whom Joseph had met by the graves in the field, Honoré Grandissime, the uttermost flower on the topmost branch of the tallest family tree ever transplanted from France to Louisiana, Honoré,—the worshiped, the magnificent,—in the broad light of the sun's going down, rode side by side with the Yankee governor and was not ashamed!

Joseph, on his bench, sat contemplating the two parties to this scandal as they came

toward him. Their horses' flanks were damp from some pleasant gallop, but their present gait was the soft, mettlesome movement of animals who will even submit to walk if their masters insist. As they wheeled out of the broad diagonal path that crossed the square, and turned toward him in the highway, he fancied that the Creole observed him. He was not mistaken. As they seemed about to pass the spot where he sat, M. Grandissime interrupted the governor with a word and turning his horse's head, rode up to the bench, lifting his hat as he came.

"Good-evening, Mr. Frhowenfeld."

Joseph, looking brighter than when he sat unaccosted, rose and blushed.

"Mr. Frhowenfeld, you know my uncle ve'y well, I believe—Agrhicolle Fusilier—long beard?"

"Oh! yes, sir, certainly."

"Well, Mr. Frhowenfeld, I shall be much obliged if you will tell him—that is, should you meet him this evening—that I wish to see him. If you will be so kind?"

"Oh! yes, sir, certainly."

Frowenfeld's diffidence made itself evident in this reiterated phrase.

"I do not know that you will see him, but if you should, you know——"

"Oh, certainly, sir!"

The two paused a single instant, exchanging a smile of amiable reminder from the horseman and of bashful but pleased acknowledgment from the one who saw his precepts being reduced to practice.

"Well, good-evening, Mr. Frhowenfeld."

M. Grandissime lifted his hat and turned. Frowenfeld sat down.

"*Bou zou, Miché Honoré!*" called the *marchande*.

"*Comment to yé, Clemence?*"

The merchant waved his hand as he rode away with his companion.

"*Beau Miché, là,*" said the *marchande*, catching Joseph's eye.

He smiled his ignorance and shook his head.

"Dass on fine gen'leman," she repeated. "*Mo pa'lé Anglé,*" she added, with a chuckle.

"You know him?"

"Oh! yass, sah; Mawse Honoré knows me, yass. All de gen'lemens knows me. I sell de *calas*; mawnin's sell *calas*, evenin's sell zinzer-cake. You know me" (a fact which Joseph had all along been aware of). "Dat me w'at pass in rous Royale ev'y mawnin' holl'in' '*Bé calas tous chauds,*' an' sing-in'; don't you know?"

The enthusiasm of an artist overcame any timidity she might have been supposed to possess, and, waiving the formality of an invitation, she began, to Frowenfeld's consternation, to sing, in a loud, nasal voice.

But the performance, long familiar, attracted no public attention, and he for whose special delight it was intended had taken an attitude of disclaimer and was again contemplating the quiet groups of the Place d'Armes and the pleasant hurry of the levee road.

"Don't you know?" persisted the woman. "Yass, sah, dass me; I's Clemence."

But Frowenfeld was looking another way.

"You know my boy," suddenly said she.

Frowenfeld looked at her.

"Yass, sah. Dat boy w'at bring you de box of basilic lass Chrismus; dass my boy."

She straightened her cakes on the tray and made some changes in their arrangement that possibly were important.

"I learned to speak English in Fijiny. Bawn dah."

She looked steadily into the apothecary's absorbed countenance for a full minute, then let her eyes wander down the highway. The human tide was turning cityward. Presently she spoke again.

"Folks comin' home a'ready, yass."

Her hearer looked down the road.

Suddenly a voice that, once heard, was always known,—deep and pompous, as if a lion roared,—sounded so close behind him as to startle him half from his seat.

"Is this a corporeal man, or must I doubt my eyes? Hah! Professor Frowenfeld!" it said.

"Mr. Fusilier!" exclaimed Frowenfeld in a subdued voice, while he blushed again and looked at the new-comer with that sort of awe which children experience in a menagerie.

"Citizen Fusilier," said the lion.

Agricola indulged to excess the grim hypocrisy of brandishing the catch-words and phrases of new-fangled reforms; they served to spice a breath that was strong with the praise of the "superior liberties of Europe,"—to wit, those old, cast-iron tyrannies which America was settled to get rid of.

Frowenfeld smiled amusedly and apologetically at the same moment.

"I am glad to meet you. I——"

He was going on to give Honoré Grandissime's message, but was interrupted.

"My young friend," rumbled the old man in his deepest key, smiling emotionally and holding and solemnly continuing to shake Joseph's hand, "I am sure you are. You ought to thank God that you have my acquaintance."

Frowenfeld colored to the temples.

"I must acknowledge——" he began.

"Ah!" growled the lion, "your beautiful modesty leads you to misconstrue me, sir. You pay my judgment no compliment. I know your worth, sir; I merely meant, sir, that in me—poor, humble me—you have secured a sympathizer in your tastes and plans. Agricola Fusilier, sir, is not a cock on a dunghill, to find a jewel and then scratch it aside."

The smile of diffidence, but not the flush, passed from the young man's face, and he sat down forcibly.

"You jest," he said.

The reply was a majestic growl.

"I never jest!" The speaker half sat down, then straightened up again. "Ah, the Marquis of Casa Calvo!—I must bow to him, though an honest man's bow is more than he deserves."

"More than he deserves?" was Frowenfeld's query.

"More than he deserves!" was the response.

"What has he done? I have never heard——"

The denunciator turned upon Frowenfeld his most royal frown, and retorted with a question which still grows wild in Louisiana:

"What"—he seemed to shake his mane—"what has he *not* done, sir?" and then he withdrew his frown slowly, as if to add, "You'll be careful next time how you cast doubt upon a public official's guilt."

The marquis's cavalcade came briskly jingling by. Frowenfeld saw within the carriage two men, one in citizen's dress, the other in a brilliant uniform. The latter leaned forward, and, with a cordiality which struck the young spectator as delightful, bowed. The immigrant glanced at Citizen Fusilier, expecting to see the greeting returned with great haughtiness; instead of which that person uncovered his leonine head, and, with a solemn sweep of his cocked hat, bowed half his length. Nay, he more than bowed, he bowed down—so that the action hurt Frowenfeld from head to foot.

"What large gentleman was that sitting on the other side?" asked the young man,

as his companion sat down with the air of having finished an oration.

"No gentleman at all!" thundered the citizen. "That fellow" (beetling frown) "that *fellow* is Edward Livingston."

"The great lawyer?"

"The great villain!"

Frowenfeld himself frowned.

The old man laid a hand upon his junior's shoulder and growled benignantly:

"My young friend, your displeasure delights me!"

The patience with which Frowenfeld was bearing all this forced a chuckle and shake of the head from the *marchande*.

Citizen Fusilier went on speaking in a manner that might be construed either as address or soliloquy, gesticulating much and occasionally letting out a fervent word that made passers look around and Joseph inwardly wince. With eyes closed and hands folded on the top of the knotted staff which he carried but never used, he delivered an apostrophe to the "spotless soul of youth," enticed by the "spirit of adventure" to "launch away upon the unplowed sea of the future!" He lifted one hand and smote the back of the other solemnly, once, twice, and again, nodding his head faintly several times without opening his eyes, as who should say, "Very impressive; go on," and so resumed; spoke of this spotless soul of youth searching under unknown latitudes for the "sunken treasures of experience"; indulged, as the reporters of our day would say, in "many beautiful flights of rhetoric," and finally depicted the loathing with which the spotless soul of youth "recoils!"—suiting the action to the word so emphatically as to make a pretty little boy who stood gaping at him start back—"on encountering in the holy chambers of public office the vultures hatched in the nests of ambition and avarice!"

Three or four persons lingered carelessly near by with ears wide open. Frowenfeld felt that he must bring this to an end, and, like any young person who has learned neither deceit nor disrespect to seniors, he attempted to reason it down.

"You do not think many of our public men are dishonest!"

"Sir!" replied the rhetorician, with a patronizing smile, "h-you must be thinking of France!"

"No, sir; of Louisiana."

"Louisiana! Dishonest? All, sir, all. They are all as corrupt as Olympus, sir!"

"Well, said Frowenfeld, with more feel-

ing than was called for, "there is one who, I feel sure, is pure. I know it by his face!"

The old man gave a look of stern interrogation.

"Governor Claiborne."

"Ye-e-e g-hods! Claiborne! *Claiborne!* Why, he is a Yankee!"

The lion glowered over the lamb like a thunder-cloud.

"He is a Virginian," said Frowenfeld.

"He is an American, and no American can be honest!"

"You are prejudiced," exclaimed the young man.

Citizen Fusilier made himself larger.

"What is prejudice? I do not know."

"I am an American myself," said Frowenfeld, rising up with his face burning.

The citizen rose up also, but unruffled.

"My beloved young friend," laying his hand heavily upon the other's shoulder, "you are not. You were merely born in America."

But Frowenfeld was not appeased.

"Hear me through," persisted the flatterer. "You were merely born in America. I, too, was born in America; but will any man responsible for his opinion mistake me—Agricola Fusilier—for an American?"

He clutched his cane in the middle and glared around, but no person seemed to be making the mistake to which he so scornfully alluded, and he was about to speak again when an outcry of alarm coming simultaneously from Joseph and the *marchande* directed his attention to a lady in danger.

The scene, as afterward recalled to the mind of the un-American citizen, included the figures of his nephew and the new governor returning up the road at a canter; but, at the time, he knew only that a lady of unmistakable gentility, her back toward him, had just gathered her robes and started to cross the road, when there was a general cry of warning, and the *marchande* cried "*garde choul!*" while the lady leaped directly into the danger and his nephew's horse knocked her to the earth!

Though there was a rush to the rescue from every direction, she was on her feet before any one could reach her, her lips compressed, nostrils dilated, cheek burning, and eyes flashing a lady's wrath upon a dismounted horseman. It was the governor. As the crowd had rushed in, the startled horses, from whom the two riders had instantly leaped, drew violently back, jerking their masters with them and leav-

ing only the governor in range of the lady's angry eye.

"Mademoiselle!" he cried, striving to reach her.

She pointed him in gasping indignation to his empty saddle, and, as the crowd farther separated them, waved away all permission to apologize and turned her back.

"Hah!" cried the crowd, echoing her humor.

"Lady," interposed the governor, "do not drive us to the rudeness of leaving——"

"*Animal, vous!*" cried half a dozen, and the lady gave him such a look of scorn that he did not finish his sentence.

"Open the way, there," called a voice in French.

It was Honoré Grandissime. But just then he saw that the lady had found the best of protectors, and the two horsemen, having no choice, remounted and rode away. As they did so, M. Grandissime called something hurriedly to Frowenfeld, on whose arm the lady hung, concerning the care of her; but his words were lost in the short yell of derision sent after them by the crowd.

Old Agricola, meanwhile, was having a trouble of his own. He had followed Joseph's wake as he pushed through the throng; but as the lady turned her face he wheeled abruptly away. This brought again in view the bench he had just left, whereupon he, in turn, cried out, and, dashing through all obstructions, rushed back to it, lifting his ugly staff as he went and flourishing it in the face of Palmyre Philosophe.

She stood beside the seat with the smile of one foiled and intensely conscious of peril, but neither frightened nor suppliant, holding back with her eyes the execution of Agricola's threat against her life.

Presently she drew a soft step backward, then another, then a third, and then turned and moved away down the avenue of willows, followed for a few steps by the lion and by the laughing comment of the *marchande*, who stood looking after them with her tray balanced on her head.

"*Ya, ya! ye connais vouldou bien!*"*

The old man turned to rejoin his companion. The day was rapidly giving place to night and the people were withdrawing to their homes. He crossed the levee, passed through the Place d'Armes and on into the city without meeting the object of his search. For Joseph and the lady had hurried off together.

As the populace floated away in knots of three, four and five, those who had witnessed mademoiselle's (?) mishap told it to those who had not; explaining that it was the accused Yankee governor who had designedly driven his horse at his utmost speed against the fair victim (some of them butted against their hearers by way of illustration); that the fiend had then maliciously laughed; that this was all the Yankees came to New Orleans for, and that there was an understanding among them—"Understanding, indeed!" exclaimed one, "They have instructions from the President!"—that unprotected ladies should be run down wherever overtaken. If you didn't believe it you could ask the tyrant, Claiborne, himself; he made no secret of it. One or two—but they were considered by others extravagant—testified that, as the lady fell, they had seen his face distorted with a horrid delight, and had heard him cry: "Daz de way to knog 'em!"

"But how came a lady to be out on the levee, at sunset, on foot and alone?" asked a citizen, and another replied—both using the French of the late province:

"As for being on foot"—a shrug. "But she was not alone; she had a *milatraise* behind her."

"Ah! so; that was well."

"But—ha, ha!—the *milatraise*, seeing her mistress out of danger, takes the opportunity to try to bring the curse upon Agricola Fusilier by sitting down where he had just risen up, and had to get away from him as quickly as possible to save her own skull."

"And left the lady?"

"Yes; and who took her to her home at last, but Frowenfeld, the apothecary!"

"Ho, ho! the astrologer! We ought to hang that fellow."

"With his books tied to his feet," suggested a third citizen. "It is no more than we owe to the community to go and smash his show-window. He had better behave himself. Come, gentlemen, a little tafia will do us good. When shall we ever get through these exciting times?"

CHAPTER XVI.

STARLIGHT IN THE RUE CHARTRES.

"OH! M'sieur Frowenfel', tague me ad home!"

It was Aurora, who caught the apothecary's arm vehemently in both her hands

* "They're up in the vouldou arts."

with a look of beautiful terror. And whatever Joseph's astronomy might have previously taught him to the contrary, he knew by his senses that the earth thereupon turned entirely over three times in two seconds.

His confused response, though unintelligible, answered all purposes, as the lady found herself the next moment hurrying across the Place d'Armes close to his side, and as they by-and-by passed its farther limits she began to be conscious that she was clinging to her protector as though she would climb up and hide under his elbow. As they turned up the rue Chartres she broke the silence.

"Oh!—h!"—breathlessly,—"'h!—M'sieur Frowenf'—you walkin' so faz!"

"Oh!" echoed Frowenfeld, "I did not know what I was doing."

"Ha, ha, ha," laughed the lady, "me, too, juz de sem lag you! *attendez*; wait."

They halted; a moment's deft manipulation of a veil turned it into a wrapping for her neck.

"'Sieur Frowenfel', oo dad man was? You know 'im?"

She returned her hand to Frowenfeld's arm and they moved on.

"The one who spoke to you, or—you know the one who got near enough to apologize is not the one whose horse struck you!"

"I din know. Bud oo dad odder one? I saw h-only 'is back, bud I thing it is de sem——"

She identified it with the back that was turned to her during her last visit to Frowenfeld's shop; but finding herself about to mention a matter so nearly connected with the purse of gold, she checked herself; but Frowenfeld, eager to say a good word for his acquaintance, ventured to extol his character while he concealed his name.

"While I have never been introduced to him, I have some acquaintance with him, and esteem him a noble gentleman."

"W'ere you meet him?"

"I met him first," he said, "at the graves of my parents and sisters."

There was a kind of hush after the mention, and the lady made no reply.

"It was some weeks after my loss," resumed Frowenfeld.

"In wad *cimetière* dad was?"

"In no cemetery—being Protestants, you know——"

"Ah, yes, sir!" with a gentle sigh.

"The physician who attended me pro-

cured permission to bury them on some private land below the city."

"Not in de groun'?"*

"Yes; that was my father's expressed wish when he died."

"You 'ad de fivver? Oo nurse you w'en you was sick?"

"An old hired negress."

"Dad was all?"

"Yes."

"Hm-m-m!" she said, piteously, and laughed in her sleeve.

Who could hope to catch and reproduce the continuous lively thrill which traversed the frame of the escaped book-worm as every moment there was repeated to his consciousness the knowledge that he was walking across the vault of heaven with the evening star on his arm—at least, that he was, at her instigation, killing time along the dim, ill-lighted *trottoirs* of the rue Chartres, with Aurora listening sympathetically at his side. But let it go; also the sweet broken English with which she now and then interrupted him; also the inward, hidden sparkle of her dancing Gallic blood; her low, merry laugh; the roguish mental reservations that lurked behind her graver speeches; the droll bravados she uttered against the powers that be, as with timid fingers he brushed from her shoulder a little remaining dust of the late encounter;—these things, we say, we let go,—as we let butterflies go rather than pin them to paper.

They had turned into the rue Bienville, and were walking toward the river, Frowenfeld in the midst of a long sentence, when a low cry of tearful delight sounded in front of them, some one in long robes glided forward, and he found his arm relieved of its burden and that burden transferred to the bosom and passionate embrace of another—we had almost said a fairer—Creole, amid a bewildering interchange of kisses and a pelting shower of Creole French.

A moment after, Frowenfeld found himself introduced to "my dotter, Clotilde," who all at once ceased her demonstrations of affection and bowed to him with a majestic sweetness, that seemed one instant grateful and the next, distant.

"I can hardly understand that you are not sisters," said Frowenfeld, a little awkwardly.

"Ah! *écoutez!*" exclaimed the younger.

"Ah! *par exemple!*" cried the elder, and

* Only Jews and paupers are buried in the ground in New Orleans.

they laughed down each other's throats, while the immigrant blushed.

This encounter was presently followed by a silent surprise when they stopped and turned before the door of No. 19, and Frowenfeld contrasted the women with their painfully humble dwelling. But therein is where your true Creole was, and still continues to be, properly, yea, delightfully un-American; the outside of his house may be as rough as the outside of a bird's nest; it is the inside that is for the birds; and the front room of this house, when the daughter presently threw open the batten shutters of its single street door, looked as bright and happy, with its candelabras glittering on the mantle, and its curtains of snowy lace, as its bright-eyed tenants.

"Sieur Frowenfel', if you pliz to come in," said Aurora, and the timid apothecary would have bravely accepted the invitation, but for a quick look which he saw the daughter give the mother; whereupon he asked, instead, permission to call at some future day, and received the cordial leave of Aurora and another bow from Clotilde.

CHAPTER XVII.

THAT NIGHT.

Do we not fail to accord to our nights their true value? We are ever giving to our days the credit and blame of all we do and mis-do, forgetting those silent, glimmering hours when plans—and sometimes plots—are laid; when resolutions are formed or changed; when heaven, and sometimes heaven's enemies, are invoked; when anger and evil thoughts are recalled, and sometimes hate made to inflame and fester; when problems are solved, riddles guessed, and things made apparent in the dark, which day refused to reveal. Our nights are the keys to our days. They explain them. They are also the days' correctors. Night's leisure untangles the mistakes of day's haste. We should not attempt to comprise our pasts in the phrase, "in those days"; we should rather say "in those days and nights."

That night was a long-remembered one to the apothecary of the rue Royale. But it was after he had closed his shop, and in his back room sat pondering the unusual experiences of the evening, that it began to be, in a higher degree, a night of events to most of those persons who had a part in its earlier incidents.

That Honoré Grandissime whom Frowenfeld had only this day learned to know as *the* Honoré Grandissime and the young governor-general were closeted together.

"What can you expect, my-de-seh?" the Creole was asking, as they confronted each other in the smoke of their choice tobacco. "Rhememba, they ah citizens by compulsion. You say yo' best and wisest law is that one prhohibiting the slave-trhade; my-de-seh, I assu'e you, prhivately, I agrhee with you; but they abhaw yo' law!

"Yo' prhincipal dangeh—at least, I mean difficultly—is this: that the Louisianais themselves, some in pu'e lawlessness, some through loss of office, some in a vague hope of phrheserhving the old condition of things, will not only hold off frhom all pa'ticipation in yo' gove'nment, but will make all sympathy with it, all advocacy of its prhinciples, and especially all office-holding under-h it, odious—disrheputable—infamous. You may find yo'self conshtrahined to fill yo' offices with men who can face down the contumely of a whole people. You know what such men generhally ah. One out of a hundrhed may be a morhal he-rho—the ninety-nine will be scamps; and the morhal he-rho will most likely get his brhains blown out ea'ly in the day.

"Count O'Reilly, when he established the Spanish powah heah thirty-five yea's ago, cut a simila' knot with the executiona's swode; but, my-de-seh, you ah heah to establish a *frhee-ee* gove'nment; and how can you make it frhee-a than the people wish it? There-h is yo' rhiddle! They hold off and say, 'Make yo' gove'nment as frhee as you can, but do not ask us to help you'; and befo' you know it you have no rhetaine's but a gang of shameless mehcenarhies, who will deseht you whenever the indignation of this people ovabalances their-h indolence; and you will fall the victim of what you may call ow mutinous pathriotism."

The governor made a very quiet, unappreciative remark about a "patriotism that lets its government get choked up with corruption and then blows it out with gunpowder!"

The Creole shrugged.

"And rhepeats the operhation indefinitely," he said.

The governor said something often heard, before and since, to the effect that communities will not sacrifice themselves for mere ideas.

"My-de-seh," replied the Creole, "you speak like a trhue Anglo-Saxon; but, seh!

how many, many communities have *committed suicide*. And this one?—why, it is *just* the kind to do it!”

“Well,” said the governor, smilingly, “you have pointed out what you consider to be the breakers, now can you point out the channel?”

“Channel? There-h is none! And you, nor-h I, cannot dig one. Two grheat fo’ces *may* ultimately do it, Rheligion and Education—as I was telling you I said to my young frriend, the apothecary,—but still I am frree to say what would be my first and phrincipal step, if I was in yo’ place—as I thank God I am not.”

The listener asked him what that was.

“Wherever-h I could find a Crheole that I could ventu’e to thrust, my-de-seh, I would put him in office. Neva mind a little political heterhodoxy, you know; almost any man can be thrusted to shoot away frhom the unifo’m he has on. And then——”

“But,” said the other, “I have offered you——”

“Oh!” replied the Creole, like a true merchant, “me, I am too busy; it is impossible! But, I say, I would *compel*, my-de-seh, this people to govern themselves!”

“And pray, how would you give a people a free government and then compel them to administer it?”

“My-de-seh, you should not give one poo’ Crheole the puzzle which belongs to yo’ whole Congrress; but you may depend on this, that the worst thing for-h all pahities—and I say it only because it is worst for-h all—would be a feeble and dilatorhy punishment of bad faith.”

When this interview finally drew to a close the governor had made a memorandum of some fifteen or twenty Grandissimes, scattered through different cantons of Louisiana, who, their kinsman Honoré thought, would not decline appointments.

Certain of the Muses were abroad that night. Faintly audible to the apothecary of the rue Royale through that deserted stillness which is yet the marked peculiarity of New Orleans streets by night, came from a neighboring slave-yard the monotonous chant and machine-like tune-beat of an African dance. There our lately met *marchande* (albeit she was but a guest, fortified against the street-watch with her master’s written “pass”) led the ancient Calinda dance and that well-known song of derision, in whose ever-multiplying stanzas

the helpless satire of a feeble race still continues to celebrate the personal failings of each newly prominent figure among the dominant caste. There was a new distich to the song to-night, signifying that the pride of the Grandissimes must find his friends now among the Yankees:

“Miché Hon’ré, allé! h-allé!
 Trouvé to zamis parmi les Yankis.
 Dancé calinda, bou-joum! bou-joum!
 Dancé calinda, bou-joum! bou-joum!”

Frowenfeld, as we have already said, had closed his shop, and was sitting in the room behind it with one arm on his table and the other on his celestial globe, watching the flicker of his small fire and musing upon the unusual experiences of the evening. Upon every side there seemed to start away from his turning glance the multiplied shadows of something wrong. The melancholy face of that Honoré Grandissime, his landlord, at whose mention Dr. Keene had thought it fair to laugh without explaining; the tall, bright-eyed *milatraise*; old Agricola; the lady of the basil; the newly-identified merchant friend, now the more satisfactory Honoré,—they all came before him in his meditation, provoking among themselves a certain discord, faint but persistent, to which he strove to close his ear. For he was brain-weary. Even in the bright recollection of the lady and her talk he became involved among shadows, and going from bad to worse, seemed at length almost to gasp in an atmosphere of hints, allusions, faint unspoken admissions, ill-concealed antipathies, unfinished speeches, mistaken identities and whisperings of hidden strife. The cathedral clock struck twelve and was answered again from the convent tower; and as the notes died away he suddenly became aware that the weird, drowsy throb of the African song and dance had been swinging drowsily in his brain for an unknown lapse of time.

The apothecary nodded once or twice, and thereupon rose up and prepared for bed, thinking to sleep till morning.

Aurora and her daughter had long ago put out their chamber light. Early in the evening the younger had made favorable mention of retiring, to which the elder replied by asking to be left awhile to her own thoughts. Clotilde, after some tender protestations, consented, and passed through the open door that showed, beyond it, their couch. The air had grown just cool and

humid enough to make the warmth of one small brand on the hearth acceptable, and before this the fair widow settled herself to gaze beyond her tiny, slippered feet into its wavering flame, and think. Her thoughts were such as to bestow upon her face that enhancement of beauty that comes of pleasant reverie, and to make it certain that that little city afforded no fairer sight,—unless, indeed, it was the figure of Clotilde just beyond the open door, as in her white night-dress enriched with the work of a diligent needle, she knelt upon the low *prie-Dieu* before the little family altar, and committed her pure soul to the Divine keeping.

Clotilde could not have been many minutes asleep when Aurora changed her mind and decided to follow. The shade upon her face had deepened for a moment into a look of trouble; but a bright philosophy, which was part of her paternal birthright, quickly chased it away, and she passed to her room, disrobed, lay softly down beside the beauty already there and smiled herself to sleep,—

“Blinded alike from sunshine and from rain,
As though a rose should shut, and be a bud
again.”

But she also wakened again, and lay beside her unconscious bed-mate, occupied with the company of her own thoughts. “Why should these little concealments ruffle my bosom? Does not even Nature herself practice wiles? Look at the innocent birds; do they build where everybody can count their eggs? And shall a poor human creature try to be better than a bird? Didn’t I say my prayers under the blanket just now?”

Her companion stirred in her sleep, and she rose upon one elbow to bend upon the sleeper a gaze of ardent admiration. “Ah, beautiful little chick! how guileless! indeed, how deficient in that respect!” She sat up in the bed and hearkened; the bell struck for midnight. Was that the hour? The fates were smiling! Surely M. Assonquer himself must have waked her to so choice an opportunity. She ought not to despise it. Now, by the application of another and easily wrought charm, that dark first hour of the morning would have, as it were, its colors set.

The night had grown much cooler. Stealthily, by degrees, she rose and left the couch. The openings of the room were a window and two doors, and these, with much caution, she contrived to open without noise. None of them exposed her to

the possibility of public view. One door looked into the dim front room; the window let in only a flood of moonlight over the top of a high house, which was without openings on that side; the other door revealed a weed-grown back yard and that invaluable protector, the cook’s hound, lying fast asleep.

In her night-clothes as she was, she stood a moment in the center of the chamber, then sank upon one knee, rapped the floor gently but audibly thrice, rose, drew a step backward, sank upon the other knee, rapped thrice, rose again, stepped backward, knelt the third time, the third time rapped, and then, rising, murmured a vow to pour upon the ground next day an oblation of champagne—then closed the doors and window and crept back to bed. Then she knew how cold she had become. It seemed as though her very marrow was frozen. She was seized with such an uncontrollable shivering that Clotilde presently opened her eyes, threw her arm about her mother’s neck, and said:

“Ah! my sweet mother, are yo’ so cold?”

“The blanket was all off of me,” said the mother, returning the embrace, and the two sank into unconsciousness together.

Into slumber sank almost at the same moment Joseph Frowenfeld. He awoke, not a great while later, to find himself standing in the middle of the floor. Three or four men had shouted at once, and three pistol-shots, almost in one instant, had resounded just outside his shop. He had barely time to throw himself into half his garments when the knocker sounded on his street-door, and when he opened it Agricola Fusilier entered, supported by his nephew Honoré on one side and Doctor Keene on the other. The latter’s right hand was pressed hard against a bloody place in Agricola’s side.

“Give us plenty of light, Frowenfeld,” said the doctor, “and a chair and some lint, and some Castile soap, and some towels and sticking-plaster, and anything else you can think of. Agricola’s about scared to death —”

“Professor Frowenfeld,” groaned the aged citizen, “I am basely and mortally stabbed!”

“Right on, Frowenfeld,” continued the doctor, “right on into the back room. Fasten that front door. Here, Agricola, sit down here. That’s right, Frow., stir up

a little fire. Give me—never mind, I'll just cut the cloth open."

There was a moment of silent suspense while the wound was being reached, and then the doctor spoke again.

"Just as I thought; only a safe and comfortable gash that will keep you in-doors a while with your arm in a sling. You are more scared than hurt, I think, old gentleman."

"You think an infernal falsehood, sir!"

"See here, sir," said the doctor, without ceasing to ply his dexterous hands in his art, "I'll jab these scissors into your back if you say that again."

"I suppose," growled the "citizen," "it is just the thing your professional researches have qualified you for, sir!"

"Just stand here, Mr. Frowenfeld," said the little doctor, settling down to a professional tone, "and hand me things as I ask for them. Honoré, please hold this arm; so." And so, after a moderate lapse of time, the treatment that medical science of those days dictated was applied—whatever that was. Let those who do not know give thanks.

M. Grandissime explained to Frowenfeld what had occurred.

"You see, I succeeded in meeting my uncle, and we went togetha to my office. My uncle keeps his accounts with me. Sometimes we look them ova. We staid until midnight; I dismissed my carriage. As we walked homewa'd we met some frriends coming out of the rhooms of the Bagatelle Club; five or six of my uncles and cousins, and also Docta Keene. We all fell a-talking of my grhandfatha's *fête de grhandpère* of next month, and went to have some coffee. When we separhated, and my uncle and my cousin Achille Grhandissime, and Docta Keene and myself came down Rhoyal strheet, out frhom that dahk alley behind yo' shop jumped a little man and stuck my uncle with a knife. If I had not caught his arm he would have killed my uncle."

"And he escaped," said the apothecary.

"No, sir!" said Agricola, with his back turned.

"I think he did. I do not think he was strhuck."

"And Mr. —, your cousin?"

"Achille? I have sent him for-h a carriage."

"Why, Agricola," said the doctor, snipping the loose ravelings from his patient's bandages, "an old man like you should not have enemies."

"I am *not* an old man, sir!"

"I said *young* man."

"I am not a *young* man, sir!"

"I wonder who the fellow was," continued Doctor Keene, as he re-adjusted the ripped sleeve.

"That is *my* affair, sir; I know who it was."

* * * * *

"And yet she insists," M. Grandissime was asking Frowenfeld, standing with his leg thrown across the celestial globe, "that I knocked heh down intentionally?"

Frowenfeld, about to answer, was interrupted by a knock on the door.

"That is my cousin, with the carriage," said M. Grandissime, following the apothecary into the shop.

Frowenfeld opened to a young man,—a rather poor specimen of the Grandissime type, deficient in stature but not in stage manner.

"*Est il mort?*" he cried at the threshold.

"Mr. Frhowenfeld, let me make you acquainted with my cousin, Achille Grhandissime."

Mr. Achille Grandissime gave Frowenfeld such a bow as we see now only in pictures.

"Ve'y 'appe to meck yo' acquaintenz!"

Agricola entered, followed by the doctor, and demanded in indignant thunder-tones, as he entered:

"Who—ordered—that—carriage?"

"I did," said Honoré. "Will you please get into it at once."

"Ah! dear Honoré!" exclaimed the old man, "always too kind! I go in it purely to please you."

Good-night was exchanged; Honoré entered the vehicle and Agricola was helped in. Achille touched his hat, bowed and waved his hand to Joseph, and shook hands with the doctor, and saying, "Well, good-night, Doctor Keene," he shut himself out of the shop with another low bow. "Think I am going to shake hands with an apothecary?" thought M. Achille.

Doctor Keene had refused Honoré's invitation to go with them.

"Frowenfeld," he said, as he stood in the middle of the shop wiping a ring with a towel and looking at his delicate, freckled hand, "I propose, before going to bed with you, to eat some of your bread and cheese. Aren't you glad?"

"I shall be, Doctor," replied the apothecary.

cary, "if you will tell me what all this means."

"Indeed I will not,—that is, not to-night. What? Why, it would take until breakfast to tell what 'all this means,'—the story of that pestiferous darky, Bras-Coupé, with the rest? Oh, no, sir. I would sooner not have any bread and cheese. What on earth has waked your curiosity so suddenly, anyhow?"

"Have you any idea who stabbed Citizen Fusilier?" was Joseph's response.

"Why, at first I thought it was the other Honoré Grandissime; but when I saw how small the fellow was, I was at a loss, completely. But, whoever it is, he has my bullet in him, whatever Honoré may think."

"Will Mr. Fusilier's wound give him much trouble?" asked Joseph, as they sat down to a luncheon at the fire.

"Hardly; he has too much of the blood of Lufki-Humma in him. But I need not say that; for the Grandissime blood is just as strong. A wonderful family, those Grandissimes! They are an old, illustrious line,

and the strength that was once in the intellect and will is going down into the muscles. I have an idea that their greatness began, hundreds of years ago, in ponderosity of arm,—of frame, say,—and developed, from generation to generation, in a rising scale, first into fineness of sinew, then, we will say, into force of will, then into power of mind, then into subtleties of genius. Now they are going back down the incline. Look at Honoré; he is high up on the scale, intellectual and sagacious. But look at him physically, too. What an exquisite mold! What compact strength! I should not wonder if he gets that from the Indian Queen. What endurance he has! He will probably go to his business by and by and not see his bed for seventeen or eighteen hours. He is the flower of the family, and possibly the last one. Now, old Agricola shows the downward grade better. Seventy-five, if he is a day, with, maybe, one-fourth the attainments he pretends to have, and still less good sense; but strong—as an orang-outang. Shall we go to bed?"

(To be continued.)

THE ACADIANS OF LOUISIANA.

ALTHOUGH the term "Acadian" is strictly appropriate only to the descendants of the Canadians and exiles from Acadie, who were among the early permanent settlers of Louisiana, it may frequently be heard applied to all the humbler classes of French origin throughout the state. Among themselves they are "*Créole Français*"; and Acadian—or rather its corruption "Cajun," as they pronounce it—is regarded as implying contempt. Indeed, the educated classes habitually designate those whom they regard as their social inferiors by the objectionable epithet. With the lower orders it is bandied from one to another in the same spirit; and none are so humble as not to feel the implied insult. If the situation is favorable, a fist fight is the result, the contest being spiced with such volleys of oaths as, were they translatable, would excite the envy of the most accomplished blasphemer of a western mining town.

These peculiar people are often spoken of as "passing away." This may be true of certain localities. On the Missis-

sippi River, for instance, where they once owned large and valuable tracts of land, they have mostly yielded before the more enterprising, energetic American, the uneducated class moving to the interior, and, as it were, finding their level among their own kind, while the more intelligent that remain are rapidly becoming Americanized—losing their distinctive characteristics through English education, social intercourse, and intermarriages with their American compatriots. But go back from the Mississippi and other navigable streams and from the various towns of importance, to the smaller bayous, where steamboats never come; to the extensive prairies where the whistle of the engine has not yet been heard, and you find genuine Acadians everywhere, unchanged, too, in character and mode of living from what they were fifty—perhaps one hundred—years ago. In fact, the first vital element of change, in the direction of progress,—education,—is lacking. In many of their settlements there are no schools whatever. Now and then a child of the more

prosperous class is sent off for a few months or, perhaps, for a year, to a Roman Catholic school. He who reads without very much halting and can write, or make others believe he can, is considered well-educated, and, with the requisite amount of shrewdness, may become an oracle in politics, and especially in business affairs, the calculations of which are "carried in the head," after the early manner of Daniel Drew.

The language here is French, corrupted more or less into a patois. This is particularly the case in settlements remote from the public highways of commerce. Take, for instance, Prairie Gros Chevreuil on the upper Têche,—that is the unnavigable portion of Bayou Têche near its source. A ride of some fifteen miles from the old town of Opelousas brings you to the farms extending along the banks of that quiet stream and stretching back from it over "the prairies of fair Opelousas." Embowered in groves of china trees you will find comfortable homes, which are always built in the same plain cottage style, weather-boarded without and plastered within, and with the inevitable *galerie* or porch in front. They vary in nothing but size. Here there are no deserted farms, no land thrown out for lack of labor, as in many parts of the South since the late war. Here, secluded from the great, busy world, not separated by natural barriers of mountains or seas, but held aloof by their own inertness, the French tongue has with most of the inhabitants degenerated into a dialect that a Parisian would be puzzled to understand. In their own opinion, however, they speak the genuine French. Why should they not, indeed? Are they not French? To be sure, they live in the Union, but as for being Americans—*parbleu!* that is quite another thing. And no one seeing them in their own homes will feel disposed to contradict them. Of Americans, as a class, they have not the highest opinion. Southerners as well as Northerners are "Yankees," unless regarded with exceptional favor. If one of their own people is shrewd or tricky in business transactions, he is unceremoniously designated a "Yankee."

Not being a migratory people, their sections are densely settled; what may originally have been a large plantation is often divided and subdivided among children and grandchildren during the life of its first proprietor until further partition is impracticable. Parents willingly sacrifice their own comfort to keep their children near them; and

the parental affection that prompts this sacrifice is filially reciprocated. The children mature and marry early, settling down on their *terrain* contentedly, be it small or otherwise, with no expectation or desire of ever leaving it, and the only subsequent improvements likely to be made are the addition of shed rooms to accommodate the rapidly increasing progeny. A girl of twelve years may take upon herself the responsibilities of wedded life with a helpmate but little older, and following the usages of their elders, these two will address and speak of each other as "*mon vieux*," "*ma vielle*" ("old man," "old woman") with a naïveté that is truly refreshing. Grand-parents who have not reached the age of thirty are not infrequent among these people.

Without overtaking themselves,—the Acadian who overworks is indeed a *rara avis*,—the most thrifty keep their places in good order, raising small crops of corn, cotton, tobacco, peas and potatoes; and highland rice, also, if the soil is favorable. Creole ponies, horned cattle and hogs, swell their possessions, and contribute to their social dignity. Add to these the *calèche* in which the family rides, and the summit of worldly grandeur is attained. By the by, the *calèche* is very unique, and merits more than a passing notice. This vehicle is of domestic manufacture; it is two wheeled, hoodless, and springless; the body is of wood, rudely fashioned after the pattern of the old-time gig, and the seats are apparently intended for two persons, but on emergency they develop a capacity for accommodating a dozen. Whether the occupants shrink to suit its dimensions, or it expands to accommodate theirs, tradition saith not. Imagine Materfamilias, crowned with an enormous sun-bonnet, in the center of the seat, with children crowded in at each side, more children at her back, still more between the seat and the low dashboard, and with the baby on her lap, guarded by maternal arms which are at the same time extended to hold the reins! "*Allons!*" The reins are lustily flapped at regular intervals, and the respectable, sedate family horse, in no wise hurried thereby, moves on in a regular jog-trot; at each forward movement the shafts fly far up above his withers, and all the clustered heads in the *calèche* are simultaneously thrown back to be jerked as suddenly forward when the shafts fall into position. Above all, the big sun-bonnet flops up and down like the limp wings of some huge bird; ludicrous as it may seem, the unaccustomed spectator is

seized with the fancy that those devoted heads must eventually yield to the oft-repeated jerks and come tumbling to the ground. This primitive vehicle is not the only article of domestic make. Baskets,

stuffed with bandanna handkerchiefs, material for "Sunday shirts," calico and cheap muslins or delaines for Sunday dresses, the "Cajun" creates an immense sensation in the family and neighborhood on his return



ACADIAN GIRL.

buckets, brooms, split-bottomed and rawhide seated chairs, besides neat, substantial specimens of cabinet ware, are common articles of manufacture. Fine, durable halters and bridle-reins are twisted of horse-hair, and tobacco is put up *en perique*. This last is the leaf tobacco rolled up in the form of a cigar, but solid and large, the average weight being three pounds. With some of the wife's choicest cottonade, it is taken by the head of the family to town, for sale or barter. These articles, being of superior quality, are easily disposed of at remunerative prices. His saddle-bags being

home. Whatever else may be needed for clothing is usually of home manufacture. The housewife usually makes palmetto hats, and spins, knits, dyes thread and weaves cloth for household use and personal wear. Domestic needs being thus to a great extent supplied among themselves, debt and its consequent embarrassments are almost unknown.

The lives of these people, from generation to generation, are a mere repetition of the same round of simple pleasures and easy work. Their want of ambition—their indifference to the higher social and political

distinctions—are often commended by those who know but little of them and like to point a moral. But the “Cajun” has his ambitions, though on so insignificant a scale as to appear almost ludicrous to those accustomed to greater things. In his little world, the lofty honors of a corner or justice of the peace are as eagerly sought and as highly estimated, as are the most prominent political positions in other quarters. Elections are attended with great excitement. Primed with their favorite tafia, or cheap whisky which they call “rote gote,”—rot-gut,—the voters are noisy and turbulent. Free fights are the order of the day; but, to their credit be it said, no weapons are used except such as are furnished by nature. To give his foe a black eye, or to make him cry “*Assez!*” is sufficient glory for the Acadian. Clannish in the extreme, the mutual relationship of candidate and voter generally outweighs personal merit and party principle; and, being almost interminably interlinked by marriages, there are few eligible aspirants who cannot claim a large number of voters on that score. Still, though blood may be thicker than water, it yields to whisky. The candidate who treats most liberally, both at home and at the *boutique*, may safely count on being elected.

The boutique, where these political ebullitions usually occur, is the only permanent place of resort for the transaction of public business and for public amusement. It is the rendezvous of a crowd that never entirely disperses until late in the night. There the men congregate seven days in the week; in greater numbers on Saturday afternoons and Sundays, to play cards and keno for small stakes,—usually not more than five cents,—to drink liquor, and to arrange for races, cock-fights, and Saturday night balls. The boutique proper is a stuffy little store, where cheap crockery, hardware, and out-of-date prints, muslins, and delaines are temptingly displayed to the admiring eyes of Acadian womankind; and where coffee, flour, and such delicacies as herring, stale brown sugar, and molasses appeal strongly, in more senses than one, to the longing appetites of all, irrespective of age or sex. But the backbone of the stock in trade is always whisky. With its addenda, the boutique is a rather complex institution. Extending from one side is a comparatively pretentious wing, that reminds one of an overgrown, conceited youth looking down upon his venerable parent as something of

an old fogey. This addition is commonly used as a gambling saloon. But it is also, at intervals, the office of the Justice of the Peace, who is clothed in the awful majesty of the law and inspired with the solemn conviction that the welfare of the nation depends to a great extent upon his official dignity. Here, too, on Saturday nights, the Acadian beauty and chivalry meet, and spend the hours dancing gracefully to the harmonious strains of the violin. Candles, in pendent tin candlesticks, shed their rays on the festive scene; and on grand occasions, which demand unusual splendor, others stuck in bottles enhance the brilliancy of the spectacle. Immediately back of the boutique is the family room, which is always filled to its utmost capacity; yet somehow, as with the *calèche*, there is always room for the frequent additions.

The sanctum of the boutique, however, is an apartment partitioned off in a way not to render it too conspicuous to outsiders. Fast young men, and delinquent Benedicts, when desirous of secrecy, retire to this room. Seated at little cypress tables, with wine glasses, a carafe of spirits, and little piles of half-dimes beside them, they feel secure, for mine host is guard upon honor against all intrusion. Not that gambling is anyway worse than any other harmless amusement! Perish the mere supposition! But if a man will leave his work for more than a few hours on week-days, or risk more money than he can afford, a little privacy is desirable. On Sunday now, and to venture only what he can spare—*eh bien!* that is another thing. What can be better than a little game to pass the time! The Acadians are pre-eminently gregarious, social and communicative, and the traditional skelton in the closet is with them an impossibility. All their joys and sorrows are discussed with the utmost frankness.

Balls are attended by young and old of both sexes. Cards and keno, horse-races and cock-fights are proper for the most respectable citizen. Their enjoyment is a matter of taste, not a question of ethics. No woman, however, is ever present at the last two entertainments. Sunday, after mass, is devoted to pleasure. Every family makes or receives visits. Numbers gather at certain houses famed for hospitality. A collation in the morning is indispensable, whether the guests be few or many. Pancakes, with molasses or honey, are handed round. If such dainties are not at com-

mand, sweet-potatoes, baked as only the Acadian housewife can bake them, are quite the rule. Coffee is always served. Not to offer some refreshment would be as unpardonable a breach of hospitality on the

and kirtle of blue. For the *grande toilette*, a dainty pink, blue or green sun-bonnet crowns her demurely coquettish head; and the *robe de l'indienne*, with closely fitting bodice and long, flowing skirts, adorns her lithe, graceful form. The *camisol*—loose gown—is the approved fashion for elderly women; for men the blouse has the preference.

“Cajun” etiquette is somewhat arbitrary. At all social gatherings, public or private, the men and women sit apart. Only during the dancing is there any freedom of intercourse; even then the girls must be sedate, speak only when spoken to, and keep their eyes modestly lowered. I once heard an Acadian woman remark, “It ess permeet of *les Americaine* to look at de mans in de face, *mais nos demoiselles!*” finishing off with a significant shrug of her shoulders. On entering a room where there is company, one must shake hands with every person in turn, whether acquainted or not. No one rises for the ceremony except, perhaps, the host or hostess. For a woman, old or young, married or single, to ride, walk, or be entirely alone for a few moments with any member of the opposite sex except father, son, or husband is a gross breach of the proprieties of which the worst may be, and is pretty certain to be, said. Nothing less than the direst extremity will make it excusable for even brother and sister, uncle and niece, to go anywhere together without the company of a third person. The only female who with safety can defy these established “usages” is that personage of supreme importance and assured privileges, the Acadian “Sairey Gamp.” As may be imagined, lovers have a difficult time of it under so many restrictions. The wooing must be done at balls or in the presence of the family. Flirting being impracticable, it is always understood that the wooer means marriage, and consequently he eagerly avails himself of the few privileges deemed by the rural Mrs. Grundy consistent with the proprieties. These usually begin with prancing, caracoling and racing his horse on the road in front of his “belle’s” dwelling-place. He repeats the performance as often as possible, and enjoys it immensely. The more spectators, the greater his delight. The sweets of courtship are necessarily expended on the old folks. Macaboy snuff à *la vanille*, a bottle of anisette, etc., for *maman* go far toward making the course of true love run smooth. With the old gentleman, tact at losing half-



A YOUNG MATRON.

part of the hostess, as for the host to omit bringing forward his carafe of tafia or whisky. Then follows dinner, which begins with gumbo and ends with black coffee. Peanuts, pop-corn or pecans help to kill time in the afternoon. All this is a matter of course, and churlish indeed must be the family that does not entertain with equal bounty the respectable stranger, or the most shiftless wretch, that may enter the gates. Longfellow says of “Acadie, home of the happy,”—

“Every house was an inn, where all were welcomed and feasted;
For with this simple people, who lived like brothers together,
All things were held in common, and what one had was another’s.”

To some extent this applies to their descendants. But the modern Evangeline has discarded the picturesque Norman cap

dimes at play is equally effective, always provided the lover comes under that comprehensive descriptive "*bon garçon*." While thus courting the parents, he avails himself of every opportunity to make "sweet eyes" at the daughter, and, after a few weeks of such wooing, proposes. The ball-room is generally the place; when the pleasurable excitement of the waltz has reached its climax, while her slender waist

daughters are admirably wise in their generation, and it is not surprising that there are very few single persons of either sex among them. From early childhood, the boy is taught to look forward to the time when he shall be a man and marry a pretty girl. The ambition increases with his growth, and he seldom makes a mercenary match. If a man has the hardihood to prefer a single life, he must bear chaffing and taunts of



CUPID ON HORSEBACK.

is encircled by his arm, and her head almost leans upon his shoulder, then comes the opportunity. If the coy maid favors his suit, he instantly seeks the approval of her parents. With that, one might think the affair settled. But no; he must obtain the permission of the numerous relatives of the bride-elect, even to the cousins, who may be of no special importance. Dressed in his nattiest suit, he proudly prances around on the grand tour, and formally asks the consent of each in turn. Advanced from the dubious position of suitor to that of *fiancé*, he and his betrothed are still under a strict surveillance that is anything but agreeable; so he naturally hastens the wedding-day that is to convert the tantalized lover into the proud and happy husband. Verily, for a simple people these parents of marriageable

lack of manliness, from his best friends. On the other hand, a man of family may attain a degree of importance that no bachelor may hope for. Weddings are occasions of general rejoicing. "No feasting and dancing—no wedding." We once asked an Acadian, who always scented the aroma of bridal banquets from afar, about a wedding which, uninvited, he had ridden many miles to attend.

"Wedding? *Ma foi!* All nonsense—no feexens at all!" replied the disappointed gourmand.

In this case the bride was in mourning. The family lived in a more intelligent community, else she would not have had the courage to have been married at a time when gayeties are prohibited.

Among the amusements of this people,

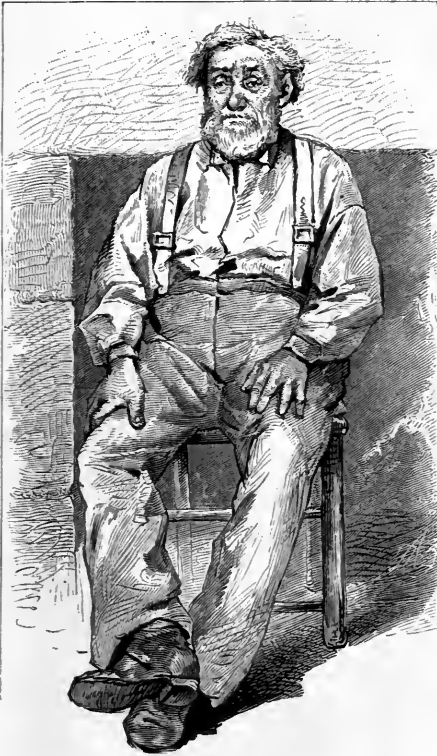

A PATRIARCH.

it would scarcely be amiss to class cases of dangerous illness and funerals, so much substantial enjoyment do they manage to get out of such events. If a person is pronounced to be in peril from some malady, men, women and children rush to the scene of suffering. Horses and calèches stand thickly around the front yard. Groups of men gossip on the galleries; the sick-room is filled with both sexes, sitting apart as usual, and all staring at the patient and keeping up an incessant talk in subdued tones. Squads of women discuss the symptoms of the sufferer, and criticise the physician's treatment. "He is French, true; but *mon Dieu!* what would you? even a French doctor cannot know everything," and they relate in turn marvelous cures performed by themselves with certain *tisanes* and cataplasms, and shake their heads wisely and sigh heavily over the hopeless condition of the sick one. Boys and girls, young men and

maidens, also make the most of the occasion by happening to meet in the back galleries, where they can throw "sheep's-eyes" at each other for one fleeting moment. Long tables are spread, one after another, with the best food which the afflicted family can offer, and coffee is served at intervals, both night and day. All this continues until the patient is restored; or until he or she is carried from the scene of decorous festivities to the grave. As may be imagined, few critical cases recover; around the bed of the dying there is no self-repression. Friends and relatives weep and lament in utter abandonment, imploring the sufferer not to leave them, and invoking all the saints in a manner most distressing even to the disinterested spectator. The priest comes, administers the last sacred rites and departs. The hapless mortal about to be ushered into eternity sees no one bending over him with calm re-assuring look, and hears no comforting, encouraging words. If the departing soul is conscious, what must it feel in this heart-rending tumult of woe?

When all is over, the corpse is arrayed as for a gala day, new shoes being indispensable. A crucifix is laid upon the breast,



AN ATTAKAPAS HERDSMAN.

lighted candles at the head and feet, a dish of holy water with a sprig of bay leaves, blessed on Palm Sunday, by the side. Every one who approaches dips the leaves in the water, and sprinkles the inanimate form, murmuring a prayer for the repose of the soul. The singing of indescribably mournful hymns is kept up during the night by some of the numerous watchers; and not until the last moment is the body placed in the coffin. The most violent demonstrations of grief attend this sad office. At the church, if the family can afford the expense, lighted candles are given to those in attendance, and are carried in the procession to the grave, where once more the loss of the dead is bewailed. All interments are in the consecrated ground of churches near or in the towns. The time for mourning their dead is regulated, as they will tell you, by their religion. For an infant, from one to three months; a child, a brother, sister, aunt or uncle, six months; father, mother, husband or wife, one year. Black is worn during the prescribed season, and all amusements are utterly foregone; music, either vocal or instrumental, is considered sacrilegious. No people exceed the Acadians in conforming to the letter of the law, whether social, civil or religious.

The Acadian woman is capricious and quick-tempered, yet amiable and warm-hearted; for her anger is soon expended and frankly deplored. Neat and industrious, she fills her rôle of housewife during the week and enjoys her gossip on Saturday afternoons and Sundays. Gossip she must have; it is the spice of her uneventful life, the sole nutriment of her mental faculties; without it her existence would be dreary stagnation. The gossiping may often lean to censoriousness, yet if the tongue thoughtlessly wounds, the heart is pitiful and the hands are ever ready to minister to all physical necessities. But whatever she may be, she is always womanly and, with rare exceptions, virtuous.

Of Acadian virtues,—which are mostly passive,—hospitality and practical charity are the most prominent. To assist a neighbor, whether in want of sustenance or in want of help, either in farming or building, is nothing more than being “a good neighbor.” The one who profits by his neighbor's extremity gains no social advancement with his ill-gotten wealth. They are not jealous, vindictive, nor greedy of wealth, and crime is almost unknown among them. Except for some poor fellow smuggling off a head or more of cattle, when the driver makes his annual tour

to buy up surplus stock for the New Orleans market, and for the brawls at the polls or at the places of amusement, the occupation of justice of the peace would soon be gone.

The men are successful and indefatigable hunters, experts in the piscatorial art, agile riders, graceful dancers, and inveterate gossips. The world at large has accorded the palm of excellence in the art of gossip to the fair sex; here, if impartial, it must bestow

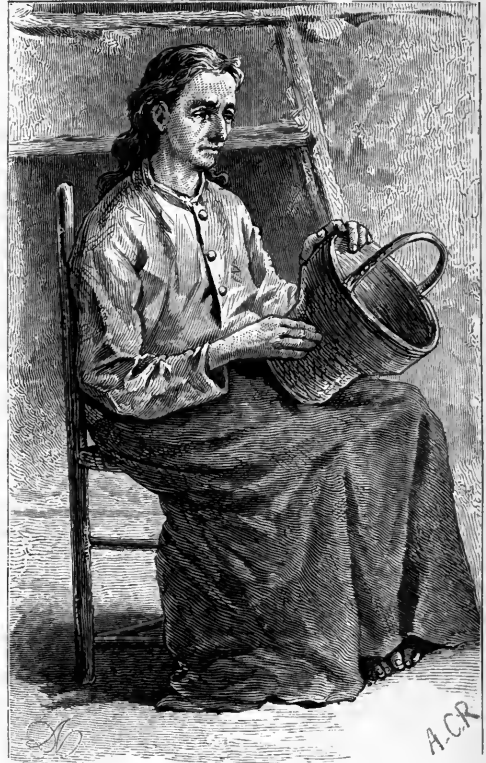

AN ACADIAN BASKET MAKER.

it on the sterner one. The very prince of gossips, with whom nothing in the feminine line, to our knowledge, can compete, is usually some genial old fellow, who has handed over his possessions to his children for a consideration. Having nothing to do but to “distract” himself,—and we may safely add, his neighbors, also,—he is always going from place to place, and always gossiping. He attends all the weddings and funerals, nurses all the sick, and cures those who get well. Of such as give up the ghost,—why, he can tell you exactly by whose fault it occurred. But, look you! it must go no further.

The sole innovation—successfully introduced for an age into these self-isolated communities—is crinoline. Long after hoops

had "gone out" in the fashionable world, a merchant of New Orleans, by way of experiment, shipped a lot which he had on hand, to various remote hamlets. Great was the consternation among the simple folk of Prairie Gros Chevreuil, when they heard of the arrival of the obnoxious merchandise. Had they not seen them when they went to town to sell their cotton and their perique? A horror! a barbarism! Good enough certainly for the Americans, and such others as are in pitiable ignorance of propriety; but for themselves—God forbid! Men of family swore that they would not be disgraced by their women making *bizarre* fools of themselves. Excitement culminated at the following Saturday-night ball, when *Madame de la boutique* appeared on the scene in gloriously expanded skirts. For once the ever-ready oaths failed the men. They gazed in dumb, open-mouthed astonishment upon this audacious traitor to their sacred social traditions. Alas for their bravado! they gazed too long! Crinoline conquered. Madame was the belle of the ball. Not a man, married or single, who did not beg the honor of her hand for quadrille or waltz. Virtuous indignation swelled the breasts of the women. "That was always the way with the men. They were forever praising plain dress to their wives and daughters; but, *ma foi!* they liked gay birds best, after all." The sequel of this dramatic episode was enacted the following week. Early on Monday morning, women on horseback and in calèches might be seen wending their way toward the boutique; this continued day after day, until the supply of "'oops"—it is the thing for them to quote English as for us to quote French—was exhausted. The New Orleans merchant doubtless plumed himself upon his astuteness, when, a few days later, an order came for another supply of these articles.

In organization, the genuine Acadian of Gros Chevreuil is inferior to his American compatriot. His average height is below the medium, and though generally well-proportioned he cannot be pronounced muscular; nor yet can he boast that vitality which sometimes proves an equivalent for physical vigor. He is generally lean in person, with a decided tendency to desiccation, that often leads to the remark, "Cajuns do not die like other people; they dry up and blow away." Not so the women, however. That *ne plus ultra* of maidenly beauty, slenderness of form, soon

expands in the matron into permanent portliness. But it is a notable fact that no matter how lowly the estate of the Acadian girl, she is seldom coarse featured, never angular in person, nor really awkward or uncouth in manner. Graceful in form and movement, she has besides the smoothest of black hair, and the brightest of liquid-jet eyes to contrast favorably with her olive-tinted complexion, making a pleasing *tout ensemble*. Although whatever may be correctly stated of the inhabitants of the Upper Têche is more or less applicable to all of the so-called "Cajuns," the inhabitants of the prairies are far superior in size, vigor and activity to the inland bayou Acadians. Whether of true Acadian descent or mixed with the old Spanish Creoles, as they are in some localities, they are notable in various degrees for their mental and physical inertia, and for their lack of enterprise. In the Atchafalaya region, on the Bayous Pierrepaup, Gotell, Des Ours, etc., they live almost exclusively on fish and water-fowl, cultivating generally nothing more than a scant supply of corn and rice for home use. On Bayou du Large, in the La Fourche country, it is much the same; the men, however, devote much of their time to hunting, supplying adjacent towns and the New Orleans market with immense quantities of ducks and venison. In situations upon which the swamp encroaches, their time is about equally divided between fishing, eating, sleeping and shaking with ague.

Where the Prairie Gros Chevreuil borders on the great Cypress swamp, the deterioration of the Acadians, due to the intermarriage of near relatives, is disagreeably conspicuous. Attend mass in any one of their neighborhoods, as the writer has done, and the first thing that strikes you is the number of yellow-green eyes, with glittering white rays in the iris, as in those of the common black cat. If you are a stranger, all of those eyes stare at you. And such a stare!—so fixed, so blank, so uncanny, you must needs have strong nerves to overcome an unpleasant chilliness that creeps at the roots of your hair, and down your spine. When you rally from the repulsive fascination of such weird eyes, you perceive that most of them gleam from faces the profiles of which are almost right angles, the point of the nose being the vertex. The majority of the men are under-sized, and narrow shouldered, with corpulent bodies, "pipe-stem" arms and legs, and sallow, wrinkled faces. As among the "Catfish

Cajuns," the women are better developed, more intelligent and energetic than the men.

The finest specimens of Acadian physique are to be found among the herdsmen of the Attakapas prairies. Superb riders, generally tall and well formed, with the black hair and large black eyes of their race, they are certainly fine-looking fellows. Some of them have developed into first-class cattle thieves, and in a few instances

French *émigré* are often gifted. Of the various churches, only the Roman Catholic has had the *entrée* here. No other could possibly have its influence, which is illimitable among them. But so far its labors have been limited to religious instruction and to establishing expensive convents and colleges in adjacent towns. Supposing these people to be ambitious, not many can afford to send their children to those



A FIVE-ACRE DASH.

they have gone a degree beyond cattle stealing. However, one must admit that no people have furnished fewer criminals than the Acadians of interior Louisiana, who live out their simple lives without knowing the outside world or being known by it. Conclusions as to their capabilities as a race can be reached only by observing the results where they have had opportunities for developing their natural endowments of body and mind. None of them, in the most favorable circumstances, manifests the enterprise, strength of character, or intellect with which the descendants of the direct

institutions for more than a few months. Good, inexpensive schools in their midst are what they need. I have been informed that when free schools were established in the parishes of St. Martin's and St. Mary's, after the close of the war, many Acadian children at first attended, but were withdrawn by their parents upon the protest of the Roman Catholic clergy against such a course. It now remains to be seen whether the "spiritual mother" will do as much for the enlightenment of her untutored, docile children as the civil authorities are willing to do.

CONFIDENCE.

BY HENRY JAMES, JR.,

Author of "The American," "The Europeans," "Daisy Miller," Etc.

CHAPTER XI.

BERNARD sat reflecting for a long time; at first with a good deal of mortification—afterward with a good deal of bitterness. At last he felt angry; but he was not angry with himself. He was displeased with poor Gordon, and with Gordon's displeasure. He was uncomfortable, and he was vexed at his discomfort. It formed, it seemed to him, no natural part of his situation; he had had no glimpse of it in the book of fate when he registered on a fair blank page his betrothal to a charming girl. That Gordon should be surprised—and even a little shocked and annoyed—this was his right and his privilege; Bernard had been prepared for that, and had determined to make the best of it. But it must not go too far; there were limits to the morsel of humble pie that he was disposed to swallow. Something in Gordon's air and figure, as he went off in a huff, looking vicious and dangerous—yes, that was positively his look—left a sinister impression on Bernard's mind, and, after a while, made him glad to take refuge in being angry. One would like to know what Gordon expected, *par exemple*. Did he expect Bernard to give up Angela simply to save him a shock; or to back out of his engagement by way of an ideal reparation? No, it was too absurd, and if Gordon had a wife of his own, why in the name of justice should not Bernard have one?

Being angry was a relief, but it was not exactly a solution, and Bernard, at last, leaving his place, where for an hour or two he had been absolutely unconscious of everything that went on around him, wandered about for some time in deep restlessness and irritation. At one moment he thought of going back to Gordon's hotel, to see him and explain. But then he became aware that he was too angry for that—to say nothing of Gordon's being too angry also; and, moreover, that there was nothing to explain. He was to marry Angela Vivian; that was a very simple fact—it needed no explanation. Was it so wonderful, so inconceivable, an accident so unlikely to happen? He went, as he always did on Sunday, to dine with Mrs. Vivian, and it seemed to him that he perceived in the two ladies

some symptoms of a discomposure which had the same origin as his own. Bernard, on this occasion, at dinner, failed to make himself particularly agreeable; he ate fast—as if he had no idea what he was eating, and talked little; every now and then his eyes rested for some time upon Angela, with a strange, vaguely excited expression, as if he were looking her over and trying to make up his mind about her afresh. This young lady bore his inscrutable scrutiny with a good deal of superficial composure; but she was also silent, and she returned his gaze, from time to time, with an air of unusual anxiety. She was thinking, of course, of Gordon, Bernard said to himself; and a woman's first meeting, in after years, with an ex-lover must always make a certain impression upon her. Gordon, however, had never been a lover, and if Bernard noted Angela's gravity it was not because he felt jealous. "She is simply sorry for him," he said to himself, and by the time he had finished his dinner it began to come back to him that he was sorry, too. Mrs. Vivian was probably sorry as well, for she had a slightly confused and preoccupied look—a look from which, even in the midst of his chagrin, Bernard extracted some entertainment. It was Mrs. Vivian's intermittent conscience that had been reminded of one of its lapses; her meeting with Gordon Wright had recalled the least exemplary episode of her life—the time when she whispered mercenary counsel in the ear of a daughter who sat, grave and pale, looking at her with eyes that wondered. Mrs. Vivian blushed a little now, when she met Bernard's eyes; and to remind herself that she was after all a superior woman, talked as much as possible about superior and harmless things—the beauty of the autumn weather, the pleasure of seeing French papas walking about on Sunday with their progeny in their hands, the peculiarities of the pulpit-oratory of the country as exemplified in the discourse of a Protestant *pasteur* whom she had been to hear in the morning.

When they rose from table and went back into her little drawing-room, she left her daughter alone for a while with Bernard. The two were standing together before the

fire; Bernard watched Mrs. Vivian close the door softly behind her. Then, looking for a moment at his companion:

"He is furious!" he announced at last.

"Furious?" said Angela. "Do you mean Mr. Wright?"

"The amiable, reasonable Gordon. He takes it very hard."

"Do you mean about me?" asked Angela.

"It's not with you he's furious, of course; it is with me. He won't let me off easily."

Angela looked for a moment at the fire.

"I am very sorry for him," she said, at last.

"It seems to me I am the one to be pitied," said Bernard; "and I don't see what compassion you, of all people in the world, owe him."

Angela again rested her eyes on the fire; then presently, looking up:

"He liked me very much," she remarked.

"All the more shame to him!" cried Bernard.

"What do you mean?" asked the girl, with her beautiful stare.

"If he liked you, why did he give you up?"

"He didn't give me up."

"What do *you* mean, please?" asked Bernard, staring back at her.

"I sent him away—I refused him," said Angela.

"Yes; but you thought better of it, and your mother had persuaded you that if he should ask you again, you had better accept him. Then it was that he backed out—in consequence of what I said to him on his return from England."

She shook her head slowly, with a strange smile.

"My poor Bernard, you are talking very wildly. *He did* ask me again."

"That night?" cried Bernard.

"The night he came back from England—the last time I saw him, until to-day."

"After I had denounced you?" our puzzled hero exclaimed, frowning portentously.

"I am sorry to let you know the small effect of your words!"

Bernard folded his hands together—almost devoutly—and stood gazing at her with a long, inarticulate murmur of satisfaction.

"Ah! then, I didn't injure you—I didn't deprive you of a chance?"

"Oh, sir, the intention on your part was the same!" Angela exclaimed.

"Then all my uneasiness, all my remorse, were wasted?" he went on.

But she kept the same tone, and its tender archness only gave a greater sweetness to his sense of relief.

"It was a very small penance for you to pay."

"You dismissed him definitely, and that was why he vanished?" asked Bernard, wondering still.

"He gave me another 'chance,' as you elegantly express it, and I declined to take advantage of it."

"Ah, well, now," cried Bernard, "I am sorry for him!"

"I was very kind—very respectful," said Angela. "I thanked him from the bottom of my heart; I begged his pardon very humbly for the wrong—if wrong it was—that I was doing him. I didn't in the least require of him that he should leave Baden at seven o'clock the next morning. I had no idea that he would do so, and that was the reason that I insisted to my mother that we ourselves should go away. When we went I knew nothing about his having gone, and I supposed he was still there. I didn't wish to meet him again."

Angela gave this information slowly, softly, with pauses between the sentences, as if she were recalling the circumstances with a certain effort, and meanwhile Bernard, with his transfigured face and his eyes fixed upon her lips, was moving excitedly about the room.

"Well, he can't accuse me, then," he broke out again. "If what I said had no more effect upon him than that, I certainly did him no wrong."

"I think you are rather vexed he didn't believe you," said Angela.

"I confess I don't understand it. He had all the air of it. He certainly had not the air of a man who was going to rush off and give you the last proof of confidence."

"It was not a proof of confidence," said Angela. "It had nothing to do with me. It was as between himself and you; it was a proof of independence. He did believe you, more or less, and what you said fell in with his own impressions—strange impressions that they were, poor man! At the same time, as I say, he liked me, too; it was out of his liking me that all his trouble came! He caught himself in the act of listening to you too credulously—and that seemed to him unmanly and dishonorable. The sensation brought with it a reaction, and to prove to himself that in such a matter he could be influenced by nobody, he marched away, an hour after he had talked

with you, and, in the teeth of his perfect mistrust, confirmed by your account of my *déportements*—heaven forgive you both!—again asked me to be his wife. But he hoped I would refuse!”

“Ah,” cried Bernard, “the recreant! He deserved—he deserved——”

“That I should accept him,” Angela asked, smiling still.

Bernard was so much affected by this revelation, it seemed to him to make such a difference in his own responsibility and to lift such a weight off his conscience, that he broke out again into the liveliest ejaculations of relief.

“Oh, I don’t care for anything, now, and I can do what I please! Gordon may hate me and I shall be sorry for him; but it’s not my fault, and I owe him no reparation. No, no; I am free!”

“It’s only I who am not, I suppose,” said Angela, “and the reparation must come from me! If he is unhappy, I must take the responsibility.”

“Ah, yes, of course,” said Bernard, kissing her.

“But why should he be unhappy?” asked Angela. “If I refused him, it was what he wanted.”

“He is hard to please,” Bernard rejoined. “He has got a wife of his own.”

“If Blanche doesn’t please him, he is certainly difficult,” and Angela mused a little. “But you told me the other day that they were getting on so well.”

“Yes, I believe I told you,” Bernard answered, musing a little too.

“You are not attending to what I say.”

“No, I am thinking of something else—I am thinking of what it was that made you refuse him that way, at the last, after you had let your mother hope.” And Bernard stood there, smiling at her.

“Don’t think any more; you will not find out,” the girl declared, turning away.

“Ah, it was cruel of you to let me think I was wrong all these years,” he went on; “and, at the time, since you meant to refuse him, you might have been more frank with me.”

“I thought my fault had been that I was too frank.”

“I was densely stupid, and you might have made me understand better.”

“Ah,” said Angela, “you ask a great deal of a girl!”

“Why have you let me go on so long thinking that my deluded words had had an effect upon Gordon—feeling that I had

done you a brutal wrong? It was real to me, the wrong—and I have told you of the pangs and the shame which, for so many months, it has cost me! Why have you never undeceived me until to-day, and then only by accident?”

At this question Angela blushed a little; then she answered, smiling:

“It was my vengeance.”

Bernard shook his head.

“That wont do—you don’t mean it. You never cared—you were too proud to care; and when I spoke to you about my fault, you didn’t even know what I meant. You might have told me, therefore, that my remorse was idle, that what I said to Gordon had not been of the smallest consequence, and that the rupture had come from yourself.”

For some time Angela said nothing, then at last she gave him one of the deeply serious looks with which her face was occasionally ornamented.

“If you want really to know, then,—can’t you see that your remorse seemed to me connected in a certain way with your affection; a sort of guarantee of it? You thought you had injured some one or other, and that seemed to be mixed up with your loving me, and therefore I let it alone.”

“Ah,” said Bernard, “my remorse is all gone, and yet I think I love you about as much as ever! So you see how wrong you were not to tell me.”

“The wrong to you I don’t care about. It is very true I might have told you for Mr. Wright’s sake. It would perhaps have made him appear better. But as you never attacked him for deserting me, it seemed needless for me to defend him.”

“I confess,” said Bernard, “I am quite at sea about Gordon’s appearance in the matter. Is he looking better now—or is he looking worse? You put it very well just now; I was attending to you, though you said I was not. If he hoped you would refuse him, with whom is his quarrel at present? And why was he so cool to me for months after we parted at Baden? If that was his state of mind, why should he accuse me of inconsistency?”

“There is something in it, after all, that a woman can understand. I don’t know whether a man can. He hoped I would refuse him, and yet when I had done so he was vexed. After a while his vexation subsided, and he married poor Blanche; but, on learning to-day that I had accepted you, it flickered up again. I suppose that was natural enough; but it wont be serious.”

"What will not be serious, my dear?" asked Mrs. Vivian, who had come back to the drawing-room, and who, apparently, could not hear that the attribute in question was wanting in any direction, without some alarm.

"Shall I tell mamma, Bernard?" said Angela.

"Ah, my dear child, I hope it's nothing that threatens your happiness," mamma murmured, with gentle earnestness.

"Does it threaten our happiness, Bernard?" Angela went on, smiling.

"Let Mrs. Vivian decide whether we ought to let it make us miserable," said Bernard. "Dear Mrs. Vivian, you are a casuist, and this is a nice case."

"Is it anything about poor Mr. Wright?" the elder lady inquired.

"Why do you say 'poor' Mr. Wright?" asked Bernard.

"Because I am sadly afraid he is not happy with Blanche."

"How did you discover that—without seeing them together?"

"Well, perhaps you will think me very fanciful," said Mrs. Vivian; "but it was by the way he looked at Angela. He has such an expressive face."

"He looked at me very kindly, mamma," Angela observed.

"He regularly stared, my daughter. In any one else I should have said it was rude. But his situation is so peculiar; and one could see that he admired you still." And Mrs. Vivian gave a little soft sigh.

"Ah! she is thinking of the thirty thousand a year," Bernard said to himself.

"I am sure I hope he admires me still," Angela cried, laughing. "There is no great harm in that."

"He was comparing you with Blanche—and he was struck with the contrast."

"It couldn't have been in my favor. If it's a question of being looked at, Blanche bears it better than I."

"Poor little Blanche!" murmured Mrs. Vivian, sweetly.

"Why did you tell me he was so happy with her?" Angela asked, turning to Bernard, abruptly.

Bernard gazed at her a moment, with his eyebrows raised.

"I never saw any one ask such sudden questions!" he exclaimed.

"You can answer me at your leisure," she rejoined, turning away.

"It was because I adored you," Bernard replied.

"You wouldn't say that at your leisure," said Angela.

Mrs. Vivian stood watching them.

"You, who are so happy together, you ought to think kindly of others who are less fortunate."

"That is very true, Mrs. Vivian; and I have never thought of any one so kindly as I have of Gordon for the last year."

Angela turned round again.

"Is Blanche so very bad, then?"

"You will see for yourself!"

"Ah, no," said Mrs. Vivian, "she is not bad; she is only very light. I am so glad she is to be near us again. I think a great deal can be done by association. We must help her, Angela. I think we helped her before."

"It is also very true that she is light, Mrs. Vivian," Bernard observed, "and if you could make her a little heavier, I should be tremendously grateful."

Bernard's prospective mother-in-law looked at him a little.

"I don't know whether you are laughing at me—I always think you are. But I shall not give up Blanche for that. I never give up any one that I have once tried to help. Blanche will come back to me."

Mrs. Vivian had hardly spoken when the sharp little vibration of her door-bell was heard in the hall. Bernard stood for a moment looking at the door of the drawing-room.

"It is poor Gordon come to make a scene!" he announced.

"Is that what you mean—that he opposed your marriage?" asked Mrs. Vivian, with a frightened look.

"I don't know what he proposes to do with Blanche," said Bernard, laughing.

There were voices in the hall. Angela had been listening.

"You say she will come back to you, mamma," she exclaimed. "Here she is arrived!"

At the same moment the door was thrown open, and Mrs. Wright appeared on the threshold with a gentleman behind her. Blanche stood an instant looking into the lighted room and hesitating—flushed a little, smiling, extremely pretty.

"May I come in?" she said, "and may I bring in Captain Lovelock?"

The two ladies, of course, advancing toward her with every demonstration of hospitality, drew her into the room, while Bernard proceeded to greet the captain, who came forward with a certain awkward and bashful majesty,

almost sweeping with his great stature Mrs. Vivian's humble ceiling. There was a tender exchange of embraces between Blanche and her friends, and the charming visitor, losing no time, began to chatter with her usual volubility. Mrs. Vivian and Angela made her companion graciously welcome; but Blanche begged they wouldn't mind him—she had only brought him as a watchdog.

"His place is on the rug," she said. "Captain Lovelock, go and lie down on the rug."

"Upon my soul, there is nothing else but rugs in these French places!" the captain rejoined, looking round Mrs. Vivian's *salon*. "Which rug do you mean?"

Mrs. Vivian had remarked to Blanche that it was very kind of her to come first, and Blanche declared that she could not have laid her head on her pillow before she had seen her dear Mrs. Vivian.

"Do you suppose I would wait because I am married?" she inquired, with a keen little smile in her charming eyes. "I am not so much married as that, I can tell you! Do you think I look much as if I were married, with no one to bring me here to-night but Captain Lovelock?"

"I am sure Captain Lovelock is a very gallant escort," said Mrs. Vivian.

"Oh, he was not afraid—that is, he was not afraid of the journey, though it lay all through those dreadful wild Champs Élysées. But when we arrived, he was afraid to come in—to come up here. Captain Lovelock is so modest, you know—in spite of all the success he had in America. He will tell you about the success he had in America; it quite makes up for the defeat of the British army in the Revolution. They *were* defeated in the Revolution, the British, weren't they? I always told him so, but he insists they were not. 'How do we come to be free, then?' I always ask him; 'I suppose you admit that we are free.' Then he becomes personal and says that I am free enough, certainly. But it's the general fact I mean; I wish you would tell him about the general fact. I think he would believe you, because he knows you know a great deal about history and all that. I don't mean this evening, but sometime when it is convenient. He didn't want to come in—he wanted to stay in the carriage and smoke a cigar; he thought you wouldn't like it,—his coming with me the first time. But I told him he needn't mind that, for I would certainly explain. I would be

very careful to let you know that I brought him only as a substitute. A substitute for whom? A substitute for my husband, of course. My dear Mrs. Vivian, of course I ought to bring you some pretty message from Gordon—that he is dying to come and see you, only that he had nineteen letters to write and that he couldn't possibly stir from his fireside. I suppose a good wife ought to invent excuses for her husband—ought to throw herself into the breach—isn't that what they call it? But I am afraid I am not a good wife. Do you think I am a good wife, Mr. Longueville? You once staid three months with us, and you had a chance to see. I don't ask you that seriously, because you never tell the truth. I always do; so I will say I am not a good wife. And then the breach is too big, and I am too little. Oh, I am too little, Mrs. Vivian; I know I am too little. I am the smallest woman living; Gordon can scarcely see me with a microscope, and I believe he has the most powerful one in America. He is going to get another here; that is one of the things he came abroad for; perhaps it will do better. I *do* tell the truth, don't I, Mrs. Vivian? I have that merit, if I haven't any other. You once told me so at Baden; you said you could say one thing for me, at any rate—that I didn't tell fibs. You were very nice to me at Baden;" Blanche went on, with her little intent smile, laying her hand in that of her hostess. "You see, I have never forgotten it. So, to keep up my reputation, I must tell the truth about Gordon. He simply said he wouldn't come—*voilà!* He gave no reason and he didn't send you any pretty message. He simply declined, and he went out somewhere else. So you see he isn't writing letters. I don't know where he can have gone; perhaps he has gone to the theater. I know it isn't proper to go to the theater on Sunday evening; but they say charity begins at home, and as Gordon's doesn't begin at home, perhaps it doesn't begin anywhere. I told him that if he wouldn't come with me I would come alone, and he said I might do as I chose—that he was not in a humor for making visits. I wanted to come to you very much; I had been thinking about it all day; and I am so fond of a visit like this in the evening, without being invited. Then I thought perhaps you had a *salon*—doesn't every one in Paris have a *salon*? I tried to have a *salon* in New York, only Gordon said it wouldn't do. He said it wasn't in our manners. Is this a *salon* to-

night, Mrs. Vivian? Oh, do say it is; I should like so much to see Captain Lovelock in a *salon*! By good fortune he happened to have been dining with us; so I told him he must bring me here. I told you I would explain, Captain Lovelock," she added, "and I hope you think I have made it clear."

The captain had turned very red during this wandering discourse. He sat pulling his beard and shifting the position which, with his stalwart person, he had taken up on a little gilded chair—a piece of furniture which every now and then gave a delicate creak.

"I always understand you well enough till you begin to explain," he rejoined, with a candid, even if embarrassed, laugh. "Then, by Jove, I'm quite in the woods. You see such a lot more in things than most people. Doesn't she, Miss Vivian?"

"Blanche has a fine imagination," said Angela, smiling frankly at the charming visitor.

When Blanche was fairly adrift upon the current of her articulate reflections, it was the habit of her companions—indeed, it was a sort of tacit agreement among them—simply to make a circle and admire. They sat about and looked at her—yawning, perhaps, a little at times, but on the whole very well entertained, and often exchanging a smiling commentary with each other. She looked at them, smiled at them each in succession. Every one had his turn, and this always helped to give Blanche an audience. Incoherent and aimless as much of her talk was, she never looked prettier than in the attitude of improvisation—or rather, I should say, than in the hundred attitudes which she assumed at such a time. Perpetually moving, she was yet constantly graceful, and while she twisted her body and turned her head, with charming hands that never ceased to gesticulate, and little, conscious, brilliant eyes that looked everywhere at once—eyes that seemed to chatter even faster than her lips—she made you forget the nonsense she poured forth, or think of it only as a part of her personal picturesqueness. The thing was a regular performance; the practice of unlimited chatter had made her perfect. She counted upon her audience and held it together, and the sight of half a dozen pairs of amused and fascinated faces led her from one piece of folly to another. On this occasion, her audience was far from failing her, for they were all greatly interested. Captain Lovelock's interest, as

we know, was chronic, and our three other friends were much occupied with a matter with which Blanche was intimately connected. Bernard, as he listened to her, smiling mechanically, was not encouraged. He remembered what Mrs. Vivian had said shortly before she came in, and it was not pleasant to him to think that Gordon had been occupied half the day in contrasting so noble a girl with this magnified butterfly. The contrast was sufficiently striking as Angela sat there near her, very still, bending her handsome head a little, with her hands crossed in her lap, and on her lips a kind but inscrutable smile. Mrs. Vivian was on the sofa next to Blanche, one of whose hands, when it was not otherwise occupied, she occasionally took into her own.

"Dear little Blanche!" she softly murmured, at intervals.

These few remarks represent a longer pause than Mrs. Wright often suffered to occur. She continued to deliver herself upon a hundred topics, and it hardly matters where we take her up.

"I haven't the least idea what we are going to do. I have nothing to say about it whatever. Gordon tells me every day I must decide, and then I ask Captain Lovelock what he thinks; because, you see, he always thinks a great deal. Captain Lovelock says he doesn't care a fig—that he will go wherever I go. So you see that doesn't carry us very far. I want to settle on some place where Captain Lovelock wont go, but he wont help me at all. I think it will look better for him not to follow us; don't you think it will look better, Mrs. Vivian? Not that I care in the least where we go—or whether Captain Lovelock follows us, either. I don't take any interest in anything, Mrs. Vivian; don't you think that is very sad? Gordon may go anywhere he likes—to St. Petersburg, or to Bombay."

"You might go to a worse place than Bombay," said Captain Lovelock, speaking with the authority of an Anglo-Indian rich in reminiscences.

Blanche gave him a little stare.

"Ah well, that's knocked on the head! From the way you speak of it, I think you would come after us; and the more I think of that, the more I see it wouldn't do. But we have got to go to some southern place, because I am very unwell. I haven't the least idea what's the matter with me, and neither has any one else; but that doesn't make any difference. It's settled that I am

out of health. One might as well be out of it as in it, for all the advantage it is. If you are out of health, at any rate you can come abroad. It was Gordon's discovery—he's always making discoveries. You see it's because I'm so silly; he can always put it down to my being an invalid. What I should like to do, Mrs. Vivian, would be to spend the winter with you—just sitting on the sofa beside you and holding your hand. It would be rather tiresome for you; but I really think it would be better for me than anything else. I have never forgotten how kind you were to me before my marriage—that summer at Baden. You were everything to me—you and Captain Lovelock. I am sure I should be happy if I never went out of this lovely room. You have got it so beautifully arranged—I mean to do my own room just like it when I go home. And you have got such lovely clothes. You never used to say anything about it, but you and Angela always had better clothes than I. Are you always so quiet and serious—never talking about *chiffons*—always reading some wonderful book? I wish you would let me come and stay with you. If you only ask me, Gordon would be too delighted. He wouldn't have to trouble about me any more. He could go and live over in the Latin Quarter—that's the desire of his heart—and think of nothing but old bottles. I know it isn't very good manners asking for an invitation," Blanche went on, smiling with a gentler radiance; "but when it's a question of one's health! One wants to keep one's self alive—doesn't one? One wants to keep one's self going. It would be so good for me, Mrs. Vivian; it would really be very good for me!"

She had turned round more and more to her hostess as she talked; and at last she had given both her hands to Mrs. Vivian, and sat looking at her with a singular mixture of earnestness and jocosity. It was hard to know whether Blanche was expressing a real desire or a momentary caprice, and whether this abrupt little petition was to be taken seriously, or treated merely as a dramatic pose in a series of more or less effective attitudes. Her smile had become almost a grimace, she was flushed, she showed her pretty teeth; but there was a little passionate quiver in her voice.

"My dear child," said Mrs. Vivian, "we should be delighted to have you pay us a visit, and we should be so happy if we could do you any good. But I am afraid you would very soon get tired of us, and I

ought to tell you, frankly, that our little home is to be—a—broken up. You know there is to be a—a change," the good lady continued, with a hesitation which apparently came from a sense of walking on uncertain ground, while she glanced with a smile at Bernard and Angela.

Blanche sat there with her little excited, yet innocent—too innocent—stare; her eyes followed Mrs. Vivian's. They met Bernard's for an instant, and for some reason, at this moment, Bernard flushed.

He rose quickly and walked away to the window, where he stood looking out into the darkness. "The devil—the devil!" he murmured to himself; she doesn't even know we are to be married—Gordon hasn't been able to trust himself to tell her! And this fact seemed pregnant with evidence as to Gordon's state of mind; it did not appear to simplify the situation. After a moment, while Bernard stood there with his back turned—he felt rather awkward and foolish—he heard Blanche begin with her little surprised voice:

"Ah, you are going away? You are going to travel? But that's charming; we can travel together. You are not going to travel? What then are you going to do? You are going back to America? Ah, but you mustn't do that, as soon as I come abroad; that's not nice or friendly, Mrs. Vivian, to your poor little old Blanche. You are not going back to America? Ah, then, I give it up! What's the great mystery? Is it something about Angela? There was always a mystery about Angela. I hope you wont mind my saying it, my dear; but I was always afraid of you. My husband—he admires you so much, you know—has often tried to explain you to me; but I have never understood. What are you going to do now? Are you going into a convent? Are you going to be—A-a-h!"

And, suddenly, quickly, interrupting herself, Mrs. Wright gave a long wondering cry. Bernard heard her spring to her feet, and the two other ladies rise from their seats. Captain Lovelock got up as well; Bernard heard him knock over his little gilded chair. There was a pause, during which Blanche went through a little mute exhibition of amazement and pleasure. Bernard turned round, to receive half a dozen quick questions.

"What are you hiding away for? What are you blushing for? I never saw you do anything like that before! Why do you look so strange? and what are you making

me say? Angela, is it true—is there something like that?” Without waiting for the answer to this last question, Blanche threw herself upon Mrs. Vivian. “My own Mrs. Vivian,” she cried, “*is* she married?”

“My dear Blanche,” said Bernard, coming forward, “has not Gordon told you? Angela and I are not married, but we hope to be before long. Gordon only knew it this morning; we ourselves have only known it a short time. There is no mystery about it, and we only want your congratulations.”

“Well, I must say you have been very quiet about it,” cried Blanche. “When I was engaged, I wrote you all a letter.”

“By Jove, she wrote to me!” observed Captain Lovelock.

Angela went to her and kissed her.

“Your husband doesn’t seem to have explained me very successfully!”

Mrs. Wright held Bernard’s betrothed for a moment at arm’s length, with both her hands, looking at her with eyes of real excitement and wonder. Then she folded her in a prolonged, an exaggerated embrace.

“Why didn’t he tell me—why didn’t he tell me?” she presently began. “He has had all day to tell me, and it was very cruel of him to let me come here without knowing it. Could anything be more absurd—more awkward? You don’t think it’s awkward—you don’t mind it? Ah well, you are very good! But I like it, Angela—I like it extremely, immensely. I think it’s delightful, and I wonder it never occurred to me. Has it been going on long? Ah, of course, it has been going on! Didn’t it begin at Baden, and didn’t I see it there? Do you mind my alluding to that? At Baden we were all so mixed up that one couldn’t tell who was attentive to whom! But Bernard has been very faithful, my dear; I can assure you of that. When he was in America he wouldn’t look at another woman. I know something about that! He staid three months in my house and he never spoke to me. Now I know why, Mr. Bernard; but you might have told me at the time. The reason was certainly good enough. I always want to know why, you know. Why Gordon never told me, for instance, that’s what I want to know!”

Blanche refused to sit down again; she declared that she was so agitated by this charming news that she could not be quiet, and that she must presently take her departure. Meanwhile she congratulated each of her friends half a dozen times; she kissed

Mrs. Vivian again, she almost kissed Bernard; she inquired about details; she longed to hear all about Angela’s “things.” Of course they would stop for the wedding; but meantime she must be very discreet; she must not intrude too much. Captain Lovelock addressed to Angela a few fragmentary, but well-intentioned sentences, pulling his beard and fixing his eyes on the door-knob—an implement which presently turned in his manly fist, as he opened the door for his companion to withdraw. Blanche went away in a flutter of ejaculations and protestations which left our three friends in Mrs. Vivian’s little drawing-room standing looking at one another as the door closed behind her.

“It certainly would have been better taste in him to tell her,” said Bernard, frowning, “and not let other people see how little communication there is between them. It has mortified her.”

“Poor Mr. Wright had his reasons,” Mrs. Vivian suggested, and then she ventured to explain: “He still cares for Angela, and it was painful to him to talk about her marrying some one else.”

This had been Bernard’s own reflection, and it was no more agreeable as Mrs. Vivian presented it; though Angela herself seemed indifferent to it—seemed, indeed, not to hear it, as if she were thinking of something else.

“We must simply marry as soon as possible—to-morrow, if necessary,” said Bernard, with some causticity. “That’s the best thing we can do for every one. When once Angela is married, Gordon will stop thinking of her. He will never permit his imagination to hover about a married woman; I am very sure of that. He doesn’t approve of that sort of thing, and he has the same law for himself as for other people.”

“It doesn’t matter,” said Angela, simply.

“How do you mean, my daughter, it doesn’t matter?”

“I don’t feel obliged to feel so sorry for him now.”

“Now? Pray, what has happened? I am more sorry than ever, since I have heard poor Blanche’s dreadful tone about him.”

The girl was silent a moment; then she shook her head, lightly.

“Her tone—her tone? Dearest mother, don’t you see? She is intensely in love with him!”

This observation struck Bernard as ex-

tremely ingenious and worthy of his mistress's fine intelligence; he greeted it with enthusiasm, and thought of it for the next twelve hours. The more he thought of it the more felicitous it seemed to him, and he went to Mrs. Vivian's the next day almost for the express purpose of saying to Angela that, decidedly, she was right. He was admitted by his old friend, the little *femme de chambre*, who had long since bestowed upon him, definitively, her confidence; and as, in the ante-chamber he heard the voice of a gentleman raised and talking with some emphasis, come to him from the *salon*, he paused a moment, looking at her with an interrogative eye.

"Yes," said Mrs. Vivian's attendant, "I must tell Monsieur frankly that another gentleman is there. Moreover, what does it matter? Monsieur would perceive it for himself!"

"Has he been here long?" asked Bernard.

"A quarter of an hour. It probably doesn't seem long to the gentleman!"

"Is he alohe with mademoiselle?"

"He asked for mademoiselle only. I introduced him into the *salon*, and mademoiselle, after conversing a little while with madame, consented to receive him. They have been alone together, as I have told monsieur, since about three o'clock. Madame is in her own apartment. The position of monsieur," added this discriminating woman, "certainly justifies him in entering the *salon*."

Bernard was quite of this opinion, and in a moment more he had crossed the threshold of the little drawing-room and closed the door behind him.

Angela sat there on a sofa, leaning back with her hands clasped in her lap and her eyes fixed upon Gordon Wright, who stood square before her as if he had been making her a resolute speech. Her face wore a look of distress, almost of alarm; she kept her place, but her eyes gave Bernard a mute welcome. Gordon turned and looked at him slowly from head to foot. Bernard remembered, with a good deal of vividness, the last look his friend had given him in the Champs Élysées the day before; and he saw with some satisfaction that this was not exactly a repetition of that expression of cold horror. It was a question, however, whether the horror was changed for the better. Poor Gordon looked intensely sad and grievously wronged. The keen resentment had faded from his face, but an immense reproach was there—a heavy, help-

less, appealing reproach. Bernard saw that he had not a scene of violence to dread—and yet, when he perceived what was coming, he would almost have preferred violence. Gordon did not offer him his hand, and before Bernard had had time to say anything, began to speak again, as if he were going on with what he had been saying to Angela.

"You have done me a great wrong—you have done me a cruel wrong. I have been telling it to Miss Vivian; I came on purpose to tell her. I can't really tell her; I can't tell her the details; it's too painful! But you know what I mean! I couldn't stand it any longer. I thought of going away—but I couldn't do that. I must come and say what I feel. I can't bear it now."

This outbreak of a passionate sense of injury in a man habitually so undemonstrative, so little disposed to call attention to himself, had in it something at once of the touching and the terrible. Bernard, for an instant, felt almost bewildered; he asked himself whether he had not, after all, been a monster of duplicity. He was guilty of the weakness of taking refuge in what is called, I believe, in legal phrase, a side-issue.

"Don't say all this before Angela," he exclaimed, with a kind of artificial energy. "You know she is not in the least at fault, and that it can only give her pain. The thing is between ourselves."

Angela was sitting there, looking up at both the men.

"I like to hear it," she said.

"You have a singular taste!" Bernard declared.

"I know it's between ourselves," cried Gordon, "and that Miss Vivian is not at fault. She is only too lovely, too wise, too good! It is you and I that are at fault—horribly at fault! You see I admit it, and you don't. I never dreamed that I should live to say such things as this to you; but I never dreamed you would do what you have done! It's horrible, most horrible, that such a difference as this should come between two men who believed themselves—or whom I believed, at least—the best friends in the world. For it is a difference—it's a great gulf, and nothing will ever fill it up. I must say so; I can't help it. You know I don't express myself easily; so, if I break out this way, you may know what I feel. I know it is a pain to Miss Vivian, and I beg her to forgive me. She has so much to forgive that she can forgive that,

too. I can't pretend to accept it; I can't sit down and let it pass. And then, it isn't only my feelings; it's the right; it's the justice. I must say to her that you have no right to marry her; and beg of her to listen to me and let you go."

"My dear Gordon, are you crazy?" Bernard demanded, with an energy which, this time at least, was sufficiently real.

"Very likely I am crazy. I am crazy with disappointment and the bitterness of what I have lost. Add to that the wretchedness of what I have found."

"Ah, don't say that, Mr. Wright," said Angela.

He stood for an instant looking at her, but not heeding her words.

"Will you listen to me again? Will you forget the wrong I did you?—my stupidity and folly and unworthiness? Will you blot out the past and let me begin again. I see you as clearly now as the light of that window. Will you give me another chance?"

Angela turned away her eyes and covered her face with her hands.

"You *do* pain me?" she murmured.

"You go too far," said Bernard. "To what position does your extraordinary proposal relegate your wife?"

Gordon turned his pleading eyes on his old friend without a ray of concession; but for a moment he hesitated.

"Don't speak to me of my wife. I have no wife."

"Ah, poor girl!" said Angela, springing up from the sofa.

"I am perfectly serious," Gordon went on, addressing himself again to her. "No, after all, I am not crazy; I see only too clearly—I see what *should* be; when people are that, you call them crazy. Bernard has no right—he must give you up. If you really care for him, you should help him. He is in a very false position; you shouldn't wish to see him in such a position. I can't explain to you—if it were even for my own sake. But Bernard must have told you; it is not possible that he has not told you?"

"I have told Angela everything, Gordon," said Bernard.

"I don't know what you mean by your having done me a wrong!" the girl exclaimed.

"If he has told you, then—I may say it!—in listening to him, in believing him."

"But you didn't believe me?" Bernard exclaimed, "since you immediately went and offered yourself to Miss Vivian?"

"I believed you all the same! When did I ever not believe you?"

"The last words I ever heard from Mr. Wright were words of the deepest kindness," said Angela.

She spoke with such a serious, tender grace, that Gordon seemed stirred to his depths again.

"Ah, give me another chance!" he moaned.

The poor girl couldn't help her tone, and it was in the same tone that she continued:

"If you think so well of me, try and be reasonable."

Gordon looked at her, slowly shaking his head.

"Reasonable—reasonable. Yes, you have a right to say that, for you are full of reason. But so am I. What I ask is within reasonable limits."

"Granting your happiness were lost," said Bernard,—“I say that only for the argument,—is that a ground for your wishing to deprive me of mine?"

"It is not yours—it is mine, that you have taken! You put me off my guard, and then you took it! Yours is elsewhere, and you are welcome to it!"

"Ah," murmured Bernard, giving him a long look and turning away, "it is well for you that I am willing still to regard you as my best friend!"

Gordon went on, more passionately, to Angela.

"He put me off my guard—I can't call it anything else. I know I gave him a great chance—I encouraged him, urged him, tempted him. But when once he had spoken, he should have stood to it. He shouldn't have had two opinions—one for me, and one for himself! He put me off my guard. It was because I still resisted him that I went to you again, that last time. But I was still afraid of you, and in my heart I believed him. As I say, I always believed him; it was his great influence upon me. He is the cleverest, the most intelligent, the most brilliant of men. I don't think that a grain less than I ever thought it," he continued, turning again to Bernard. "I think it only the more, and I don't wonder that you find a woman to believe it. But what have you done but deceive me? It was just my belief in your intelligence that re-assured me. When Miss Vivian refused me a second time, and I left Baden, it was at first with a sort of relief. But there came back a better feeling—a feeling faint compared to this feeling of today, but strong enough to make me uneasy and to fill me with regret. To quench my

regret, I kept thinking of what you had said, and it kept me quiet. Your word had such weight with me."

"How many times more would you have wished to be refused, and how many refusals would have been required to give me my liberty?" asked Bernard.

"That question means nothing, because you never knew that I had again offered myself to Miss Vivian."

"No; you told me very little, considering all that you made me tell you."

"I told you beforehand that I should do exactly as I chose."

"You should have allowed me the same liberty."

"Liberty!" cried Gordon. "Hadn't you liberty to range the whole world over? Couldn't he have found a thousand other women?"

"It is not for me to think so," said Angela, smiling a little.

Gordon looked at her a moment.

"Ah, you cared for him from the first!" he cried.

"I had seen him before I ever saw you," said the girl.

Bernard suppressed an exclamation. There seemed to flash through these words a sort of retrospective confession which told him something that she had never directly told him. She blushed as soon as she had spoken, and Bernard found a beauty in this of which the brightness blinded him to the awkward aspect of the fact she had just presented to Gordon. At this fact Gordon stood staring; then at last he apprehended it—largely.

"Ah, then, it had been a plot between you!" he cried out.

Bernard and Angela exchanged a glance of pity.

"We had met for five minutes, and had exchanged a few words before I came to Baden. It was in Italy—at Siena. It was a simple accident that I never told you," Bernard explained.

"I wished that nothing should be said about it," said Angela.

"Ah, you loved him!" Gordon exclaimed.

Angela turned away. She went to the window. Bernard followed her for three seconds with his eyes; then he went on—

"If it were so, I had no reason to suppose it. You have accused me of deceiving you, but I deceived only myself. You say I put you off your guard, but you should rather say you put me on mine. It was thanks to that that I fell into the most

senseless, the most brutal of delusions. The delusion passed away—it had contained the germ of better things. I saw my error, and I bitterly repented of it; and on the day you were married I felt free."

"Ah, yes, I have no doubt you waited for that!" cried Gordon. "It may interest you to know that my marriage is a miserable failure."

"I am sorry to hear it—but I can't help it."

"You have seen it with your own eyes! You know all about it, and I needn't tell you."

"My dear Mr. Wright," said Angela, pleadingly, turning round, "in heaven's name, don't say that!"

"Why shouldn't I say it? I came here on purpose to say it. I came here with an intention—with a plan. You know what Blanche is—you needn't pretend, for kindness to me, that you don't. You know what a precious, what an inestimable wife she must make me—how devoted, how sympathetic she must be, and what a household blessing at every hour of the day! Bernard can tell you all about us—he has seen us in the sanctity of our home." Gordon gave a bitter laugh and went on, with the same strange, serious air of explaining his plan. "She despises me, she hates me, she cares no more for me than for the button on her glove, by which I mean that she doesn't care a hundredth part as much. You may say that it serves me right, and that I have got what I deserve. I married her because she was silly. I wanted a silly wife; I had an idea you were too wise. Oh, yes, that's what I thought of you! Blanche knew why I picked her out, and undertook to supply the article required. Heaven forgive her! She has certainly kept her engagement. But you can imagine how it must have made her like me—knowing why I picked her out. She has disappointed me all the same. I thought she had a heart; but that was a mistake. It doesn't matter, though, because everything is over between us."

"What do you mean, everything is over?" Bernard demanded.

"Everything will be over in a few weeks. Then I can speak to Miss Vivian seriously."

"Ah! I am glad to hear this is not serious," said Bernard.

"Miss Vivian, wait a few weeks," Gordon went on. "Give me another chance then. Then it will be perfectly right; I shall be free."

"You speak as if you were going to put an end to your wife!"

"She is rapidly putting an end to herself. She means to leave me."

"Poor, unhappy man, do you know what you are saying?" Angela murmured.

"Perfectly. I came here to say it. She means to leave me, and I mean to offer her every facility. She is dying to take a lover, and she has got an excellent one waiting for her. Bernard knows whom I mean; I don't know whether you do. She was ready to take one three months after our marriage. It is really very good of her to have waited all this time; but I don't think she can go more than a week or two longer. She is recommended a southern climate, and I am pretty sure that in the course of another ten days I may count upon their starting together for the shores of the Mediterranean. The shores of the Mediterranean, you know, are lovely, and I hope they will do her a world of good. As soon as they have left Paris I will let you know; and then you will of course admit that, virtually, I am free."

"I don't understand you."

"I suppose you are aware," said Gordon, "that we have the advantage of being natives of a country in which marriages may be legally dissolved."

Angela stared; then, softly—

"Are you speaking of a divorce?"

"I believe that is what they call it," Gordon answered, gazing back at her with his densely clouded blue eyes. "The lawyers do it for you; and if she goes away with Lovelock, nothing will be more simple than for me to have it arranged."

Angela stared, I say; and Bernard was staring, too. Then the latter, turning away, broke out into a tremendous, irrepressible laugh.

Gordon looked at him a moment; then he said to Angela, with a deeper tremor in his voice:

"He was my dearest friend."

"I never felt more devoted to you than at this moment!" Bernard declared, smiling still.

Gordon had fixed his somber eyes upon Angela again.

"Do you understand me now?"

Angela looked back at him for some moments.

"Yes," she murmured at last.

"And will you wait, and give me another chance?"

"Yes," she said, in the same tone.

Bernard uttered a quick exclamation, but Angela checked him with a glance, and Gordon looked from one of them to the other.

"Can I trust you?" Gordon asked.

"I will make you happy," said Angela.

Bernard wondered what under the sun she meant; but he thought he might safely add:

"I will abide by her choice."

Gordon actually began to smile.

"It wont be long, I think; two or three weeks."

Angela made no answer to this; she fixed her eyes a little on the floor.

"I shall see Blanche as often as possible," she presently said.

"By all means! The more you see her the better you will understand me."

"I understand you very well now. But you have shaken me very much, and you must leave me. I shall see you also—often."

Gordon took up his hat and stick; he saw that Bernard did not do the same.

"And Bernard?" he exclaimed.

"I shall ask him to leave Paris," said Angela.

"Will you go?"

"I will do what Angela requests," said Bernard.

"You have heard what she requests; it's for you to come now."

"Ah, you must at least allow me to take leave!" cried Bernard.

Gordon went to the door, and when he had opened it he stood for a while, holding it and looking at his companions. Then—

"I assure you she wont be long!" he said to Angela, and rapidly passed out.

The others stood silent till they heard the outer door of the apartment close behind him.

"And now please to elucidate!" said Bernard, folding his arms.

Angela gave no answer for some moments; then she turned upon him a smile which appeared incongruous, but which her words presently helped to explain.

"He is intensely in love with his wife!"

CHAPTER XII.

THIS statement was very effective, but it might well have seemed at first to do more credit to her satiric powers than to her faculty of observation. This was the light in which it presented itself to Bernard; but, little by little, as she amplified the text, he

grew to think well of it, and at last he was quite ready to place it, as a triumph of sagacity, on a level with that other discovery which she had made the evening before, and with regard to which his especial errand to-day had been to congratulate her afresh. It brought him, however, less satisfaction than it appeared to bring to his clever companion; for, as he observed plausibly enough, Gordon was quite out of his head, and, this being the case, of what importance was the secret of his heart?

"The secret of his heart and the condition of his head are one and the same thing," said Angela. "He is turned upside down by the complete misunderstanding that he has got into with his wife. She has treated him badly, but he has treated her wrongly. They are in love with each other, and yet they both do nothing but hide it. He is not in the least in love with poor me—not to-day any more than he was three years ago. He thinks he is, because he is full of sorrow and bitterness, and because the news of our engagement has given him a shock. But that's only a pretext—a chance to pour out the grief and pain which have been accumulating in his heart under a sense of his estrangement from Blanche. He is too proud to attribute his feelings to that cause, even to himself; but he wanted to cry out and say he was hurt, to demand justice for a wrong, and the revelation of the state of things between you and me—which of course strikes him as incongruous; we must allow largely for that—came to him as a sudden opportunity. No, no," the girl went on, with a generous ardor in her face, following further the train of her argument, which she appeared to find extremely attractive, "I know what you are going to say and I deny it. I am not fanciful, or sophistical, or irrational, and I know perfectly what I am about. Men are so stupid; it's only women that have real discernment. Leave me alone, and I shall do something. Blanche is silly, yes, very silly, but she is not so bad as her husband accused her of being, in those dreadful words which he will live to repent of. She is wise enough to care for him, greatly, at bottom, and to feel her little heart filled with rage and shame that he doesn't appear to care for her. If he would take her a little more seriously—it's an immense pity he married her *because* she was silly!—she would be flattered by it, and she would try and deserve it. No, no, no! she doesn't, in reality, care a straw for Captain Lovelock, I assure

you, I promise you she doesn't. A woman can tell. She's in danger, possibly, and if her present situation, as regards her husband, lasts, she might do something as horrid as he said. But she would do it out of spite—not out of affection for the captain, who must be got immediately out of the way. She only keeps him to torment her husband and make Gordon come back to her. She would drop him forever to-morrow." Angela paused a moment, reflecting, with a kindled eye. "And she shall!"

Bernard looked incredulous.

"How will that be, Miss Solomon?"

"You shall see when you come back."

"When I come back? Pray, where am I going?"

"You will leave Paris for a fortnight—as I promised our poor friend."

Bernard gave an irate laugh.

"My dear girl, you are ridiculous! Your promising it was almost as childish as his asking it."

"To play with a child you must be childish. Just see the effect of this abominable passion of love, which you have been crying up to me so! By its operation Gordon Wright, the most sensible man of our acquaintance, is reduced to the level of infancy! If you will only go away, I will manage him."

"You certainly manage me! Pray, where shall I go?"

"Wherever you choose. I will write to you every day."

"That will be an inducement," said Bernard. "You know I have never received a letter from you."

"I write the most delightful ones!" Angela exclaimed; and she succeeded in making him promise to start that night for London.

He had just done so when Mrs. Vivian presented herself, and the good lady was not a little astonished at being informed of his intention.

"You surely are not going to give up my daughter to oblige Mr. Wright?" she observed.

"Upon my word, I feel as if I were!" said Bernard.

"I will explain it, dear mamma," said Angela. "It is very interesting. Mr. Wright has made a most fearful scene; the state of things between him and Blanche is dreadful."

Mrs. Vivian opened her clear eyes.

"You really speak as if you liked it!"

"She does like it—she told Gordon so,"

said Bernard. "I don't know what she is up to! Gordon has taken leave of his wits; he wishes to put away his wife."

"To put her away?"

"To repudiate her, as the historians say!"

"To repudiate little Blanche!" murmured Mrs. Vivian, as if she were struck with the incongruity of the operation.

"I mean to keep them together," said Angela, with a firm decision.

Her mother looked at her with admiration.

"My dear daughter, I will assist you."

The two ladies had such an air of mysterious competence for the task they had undertaken that it seemed to Bernard that nothing was left to him but to retire into temporary exile. He accordingly betook himself to London, where he had social resources which would, perhaps, make exile endurable. He found himself, however, little disposed to avail himself of these resources, and he treated himself to no pleasures but those of memory and expectation. He ached with a sense of his absence from Mrs. Vivian's deeply familiar sky-parlor, which seemed to him for the time the most sacred spot on earth—if on earth it could be called—and he consigned to those generous postal receptacles, which ornament with their brilliant hue the London street-corners, an inordinate number of the most voluminous epistles that had ever been dropped into them. He took long walks, alone, and thought all the way of Angela, to whom, it seemed to him, that the character of ministering angel was extremely becoming. She was faithful to her promise of writing to him every day, and she was an angel who wielded—so at least Bernard thought, and he was fastidious about letters—a very clever pen. Of course she had only one topic—the success of her operations with regard to Gordon. "Mamma has undertaken Blanche," she wrote, "and I am devoting myself to Mr. Wright. It is really very interesting." She told Bernard all about it in detail, and he also found it interesting; doubly so, indeed, for it must be confessed that the charming figure of the mistress of his affections, attempting to heal a great social breach with her light and delicate hands, divided his attention pretty equally with the distracted, the distorted, the almost ludicrous image of his old friend.

Angela wrote that Gordon had come back to see her the day after his first visit, and had seemed greatly troubled on learn-

ing that Bernard had taken himself off. "'It was because you insisted on it, of course,' he said; 'it was not from feeling the justice of it himself.' I told him," said Angela, in her letter, "that I had made a point of it, but that we certainly ought to give you a little credit for it. But I couldn't insist upon this, for fear of sounding a wrong note and exciting afresh what I suppose he would be pleased to term his jealousy. He asked me where you had gone, and when I told him—'Ah, how he must hate me!' he exclaimed. 'There you are quite wrong,' I answered. 'He feels as kindly to you as—as I do.' He looked as if he by no means believed this; but, indeed, he looks as if he believed nothing at all. He is quite upset and demoralized. He staid half an hour and paid me his visit—trying hard to 'please' me again! Poor man, he is in a charming state to please the fair sex! But if he doesn't please me, he interests me more and more; I make bold to say that to you. You would have said it would be very awkward; but, strangely enough, I found it very easy. I suppose it is because I am so interested. Very likely it was awkward for him, poor fellow, for I can certify that he was not a whit happier at the end of his half-hour, in spite of the privilege he had enjoyed. He said nothing more about you, and we talked of Paris and New York, of Baden and Rome. Imagine the situation! I shall make no resistance whatever to it; I shall simply let him perceive that conversing with me on these topics does not make him feel a bit more comfortable, and that he must look elsewhere for a remedy. I said not a word about Blanche."

She spoke of her, however, the next time. "He came again this afternoon," she said in her second letter, "and he wore exactly the same face as yesterday—namely, a very unhappy one. If I were not entirely too wise to believe his account of himself, I might suppose that he was unhappy because Blanche shows symptoms of not taking flight. She has been with us a great deal—she has no idea what is going on—and I can't honestly say that she chatters any less than usual. But she is greatly interested in certain shops that she is buying out, and especially in her visits to her tailors. Mamma has proposed to her—in view of your absence—to come and stay with us, and she doesn't seem afraid of the idea. I told her husband to-day that we had asked her, and that we hoped he had no objection.

'None whatever; but she wont come.' 'On the contrary, she says she will.' 'She will pretend to up to the last minute; and then she will find a pretext for backing out.' 'Decidedly, you think very ill of her,' I said. 'She hates me,' he answered, looking at me strangely. 'You say that of every one,' I said. 'Yesterday you said it of Bernard.' 'Ah, for him there would be more reason!' he exclaimed. 'I wont attempt to answer for Bernard,' I went on, 'but I will answer for Blanche. Your idea of her hating you is a miserable delusion. She cares for you more than for any one in the world. You only misunderstand each other, and with a little good will on both sides you can easily get out of your tangle.' But he wouldn't listen to me; he stopped me short. I saw I should excite him if I insisted; so I dropped the subject. But it is not for long; he *shall* listen to me."

Later she wrote that Blanche had in fact "backed out," and would not come to stay with them, having given as an excuse that she was perpetually trying on dresses, and that at Mrs. Vivian's she should be at an inconvenient distance from the temple of these sacred rites and the high priest who conducted the worship. "But we see her every day," said Angela, "and mamma is constantly with her. She likes mamma better than me. Mamma listens to her a great deal and talks to her a little—I can't do either when we are alone. I don't know what she says—I mean what mamma says; what Blanche says I know as well as if I heard it. We see nothing of Captain Lovelock, and mamma tells me she has not spoken of him for two days. She thinks this is a better symptom, but I am not so sure. Poor Mr. Wright treats it as a great triumph that Blanche should behave as he foretold. He is welcome to the comfort he can get out of this, for he certainly gets none from anything else. The society of your correspondent is not that balm to his spirit which he appeared to expect, and this, in spite of the fact that I have been as gentle and kind with him as I know how to be. He is very silent—he sometimes sits for ten minutes without speaking; I assure you it isn't amusing. Sometimes he looks at me as if he were going to break out with that crazy idea to which he treated me the other day. But he says nothing, and then I see that he is not thinking of me—he is simply thinking of Blanche. The more he thinks of her the better."

"My dear Bernard," she began on an-

other occasion, "I hope you are not dying of *ennui*, etc. Over here things are going so-so. He asked me yesterday to go with him to the Louvre, and we walked about among the pictures for half an hour. Mamma thinks it a very strange sort of thing for me to be doing, and though she delights, of all things, in a good cause, she is not sure that this cause is good enough to justify the means. I admit that the means are very singular, and as far as the Louvre is concerned, they were not successful. We sat and looked for a quarter of an hour at the great Venus who has lost her arms, and he said never a word. I think he doesn't know what to say. Before we separated he asked me if I heard from you. 'Oh, yes,' I said, 'every day.' 'And does he speak of me?' 'Never!' I answered; and I think he looked disappointed." Bernard had, in fact, in writing to Angela, scarcely mentioned his name. "He had not been here for two days," she continued, at the end of a week; 'but last evening, very late—too late for a visitor, he came in. Mamma had left the drawing-room, and I was sitting alone; I immediately saw that we had reached a crisis. I thought at first he was going to tell me that Blanche had carried out his prediction; but I presently saw that this was not it; and, besides, I knew that mamma was watching her too closely. 'How can I have ever been such a dull-souled idiot?' he broke out, as soon as he had got into the room. 'I like to hear you say that,' I said, 'because it doesn't seem to me that you have been at all wise.' 'You are cleverness, kindness, tact, in the most perfect form!' he went on. As a voracious historian I am bound to tell you that he paid me a bushel of compliments, and thanked me in the most flattering terms for my having let him bore me so for a week. 'You have not bored me,' I said; 'you have interested me.' 'Yes,' he cried, 'as a curious case of monomania. It's a part of your kindness to say that; but I know I have bored you to death; and the end of it all is that you despise me. You can't help despising me; I despise myself. I used to think that I was a man, but I have given that up; I am a poor creature! I used to think I could take things quietly and bear them bravely. But I can't! If it were not for very shame I could sit here and cry to you.' 'Don't mind me,' I said; 'you know it is a part of our agreement that I was not to be critical.' 'Our agreement?' he repeated, vaguely. 'I see you have forgotten it,' I answered;

'but it doesn't in the least matter; it is not of that I wish to talk to you,—all the more that it hasn't done you a particle of good. I have been extremely nice with you for a week; but you are just as unhappy now as you were at the beginning. Indeed, I think you are rather worse.' 'Heaven forgive me, Miss Vivian, I believe I am!' he cried. 'Heaven will easily forgive you; you are on the wrong road. To catch up with your happiness, which has been running away from you, you must take another; you must travel in the same direction as Blanche; you must not separate yourself from your wife.' At the sound of Blanche's name he jumped up and took his usual tone; he knew all about his wife, and needed no information. But I made him sit down again, and I made him listen to me. I made him listen for half an hour, and at the end of the time he was interested. He had all the appearance of it; he sat gazing at me, and at last the tears came into his eyes. I believe I had a moment of eloquence. I don't know what I said nor how I said it; to what point it would bear examination, nor how, if you had been there, it would seem to you, as a disinterested critic, to hang together; but I know that after a while there were tears in my own eyes. I begged him not to give up Blanche; I assured him that she was not so foolish as she seems; that she was a very delicate little creature to handle, and that, in reality, whatever she did, she was thinking only of him. He had been all goodness and kindness to her, I knew that; but he had not, from the first, been able to conceal from her that he regarded her chiefly as a pretty kitten. She wished to be more than that, and she took refuge in flirting, simply to excite his jealousy and make him feel strongly about her. He has felt strongly, and he was feeling strongly now; he was feeling passionately—that was my whole contention. But he had perhaps never made it plain to those rather near-sighted little mental eyes of hers, and he had let her suppose something that couldn't fail to rankle in her mind and torment it. 'You have let her suppose,' I said, 'that you were thinking of me, and the poor girl has been jealous of me. I know it, but from nothing she herself has said. She has said nothing; she has been too proud and too considerate. If you don't think that's to her honor, I do. She has had a chance every day for a week, but she has treated me without a grain of spite. I have appreciated it, I have under-

stood it, and it has touched me very much. It ought to touch you, Mr. Wright. When she heard I was engaged to Mr. Longueville, it gave her an immense relief. And yet, at the same moment you were protesting, and denouncing, and saying those horrible things about her! I know how she appears—she likes admiration. But the admiration which of all in the world she would most delight in just now would be yours. She plays with Captain Lovelock as a child does with a wooden harlequin, she pulls a string and he throws up his arms and legs. She has about as much intention of eloping with him as a little girl might have of eloping with a pasteboard Jim Crow. If you were to have a frank explanation with her, Blanche would very soon throw Jim Crow out of the window. I very humbly entreat you to cease thinking of me. I don't know what wrong you have ever done me, or what kindness I have ever done you, that you should feel obliged to trouble your head about me. You see all I am—I tell you now. I am nothing in the least remarkable. As for your thinking ill of me at Baden, I never knew it nor cared about it. If it had been so, you see how I should have got over it. Dear Mr. Wright, we might be such good friends, if you would only believe me. She's so pretty, so charming, so universally admired. You said just now you had bored me, but it's nothing—in spite of all the compliments you have paid me—to the way I have bored you. If *she* could only know it—that I have bored you! Let her see for half an hour that I am out of your mind—the rest will take care of itself. She might so easily have made a quarrel with me. The way she has behaved to me is one of the prettiest things I have ever seen, and you shall see the way I shall always behave to her! Don't think it necessary to say out of politeness that I have not bored you; it is not in the least necessary. You know perfectly well that you are disappointed in the charm of my society. And I have done my best, too. I can honestly affirm that!' For some time he said nothing, and then he remarked that I was very clever, but he didn't see a word of sense in what I said. 'It only proves,' I said, 'that the merit of my conversation is smaller than you had taken it into your head to fancy. But I have done you good, all the same. Don't contradict me; you don't know yet; and it's too late for us to argue about it. You will tell me to-morrow.'

Some three evenings after he received this last report of the progress of affairs in Paris, Bernard, upon whom the burden of exile sat none the more lightly as the days went on, turned out of the Strand into one of the theaters. He had been gloomily pushing his way through the various London densities—the November fog, the nocturnal darkness, the jostling crowd. He was too restless to do anything but walk, and he had been saying to himself, for the thousandth time, that if he had been guilty of a misdemeanor in succumbing to the attractions of the admirable girl who showed to such advantage in letters of twelve pages, his fault was richly expiated by these days of impatience and bereavement. He gave little heed to the play; his thoughts were elsewhere, and, while they rambled, his eyes wandered round the house. Suddenly, on the other side of it, he beheld Captain Lovelock, seated squarely in his orchestra-stall, but, if Bernard was not mistaken, paying as little attention to the stage as he himself had done. The captain's eyes, it is true, were fixed upon the scene; his head was bent a little, his magnificent beard rippled over the expanse of his shirt-front. But Bernard was not slow to see that his gaze was heavy and opaque, and that, though he was staring at the actresses, their charms were lost upon him. He saw that, like himself, poor Lovelock had matter for reflection in his manly breast, and he concluded that Blanche's ponderous swain was also suffering from a sense of disjunction. Lovelock sat in the same posture all the evening, and that his imagination had not projected itself into the play was proved by the fact that during the *entr'actes* he gazed with the same dull fixedness at the curtain. Bernard forbore to interrupt him; we know that he was not at this moment socially inclined, and he judged that the captain was as little so, inasmuch as causes, even more imperious than those which had operated in his own case, must have been at the bottom of his sudden appearance in London. On leaving the theater, however, Bernard found himself detained with the crowd in the vestibule near the door, which, wide open to the street, was the scene of agitation and confusion. It had come on to rain, and the raw dampness mingled itself with the dusky uproar of the Strand. At last, among the press of people, as he was passing out, our hero became aware that he had been brought into contact with Lovelock, who was walking

just beside him. At the same moment Lovelock noticed him—looked at him for an instant, and then looked away. But he looked back again the next instant, and the two men then uttered that inarticulate and inexpressive exclamation which passes for a sign of greeting among gentlemen of the Anglo-Saxon race, in their moments of more acute self-consciousness.

"Oh, are you here?" said Bernard. "I thought you were in Paris."

"No; I aint in Paris," Lovelock answered, with some dryness. "Tired of the beastly hole!"

"Oh, I see," said Bernard. "Excuse me while I put up my umbrella."

He put up his umbrella, and from under it, the next moment, he saw the captain waving two fingers at him out of the front of a hansom. When he returned to his hotel he found on his table a letter, superscribed in Gordon Wright's hand. This communication ran as follows:

"I believe you are making a fool of me. In heaven's name, come back to Paris! G. W."

Bernard hardly knew whether to regard these few words as a further declaration of war, or as an overture to peace; but he lost no time in complying with the summons they conveyed. He started for Paris the next morning, and in the evening, after he had removed the stains of his journey and swallowed a hasty dinner, he rang at Mrs. Vivian's door. This lady and her daughter gave him a welcome which—I will not say satisfied him, but which, at least, did something toward soothing the still unhealed wounds of separation.

"And what is the news of Gordon?" he presently asked.

"We have not seen him in three days," said Angela.

"He is cured, dear Bernard; he must be. Angela has been wonderful," Mrs. Vivian declared.

"You should have seen mamma with Blanche," her daughter said, smiling. "It was most remarkable."

Mrs. Vivian smiled, too, very gently.

"Dear little Blanche! Captain Lovelock has gone to London."

"Yes, he thinks it a beastly hole. Ah, no," Bernard added, "I have got it wrong."

But it little mattered. Late that night, on his return to his own rooms, Bernard sat gazing at his fire. He had not begun to undress. He was thinking of a good many things. He was in the midst of his reflec-

tions when there came a rap at his door, which the next moment was flung open. Gordon Wright stood there, looking at him—with a gaze which Bernard returned for a moment before bidding him to come in. Gordon came in and came up to him; then he held out his hand. Bernard took it with great satisfaction. His last feeling had been that he was very weary of this ridiculous quarrel, and it was an extreme relief to find it was over.

"It was very good of you to go to London," said Gordon, looking at him with all the old serious honesty of his eyes.

"I have always tried to do what I could to oblige you," Bernard answered, smiling.

"You must have cursed me over there," Gordon went on.

"I did, a little. As you were cursing me here, it was permissible."

"That's over now," said Gordon. "I came to welcome you back. It seemed to me I couldn't lay my head on my pillow without speaking to you."

"I am glad to get back," Bernard admitted, smiling still. "I can't deny that. And I find you as I believed I should." Then he added, seriously—"I knew Angela would keep us good friends."

For a moment Gordon said nothing. Then, at last he replied:

"Yes, for that purpose it didn't matter which of us should marry her. If it had been I," he added, "she would have made you accept it."

"Ah, I don't know!" Bernard exclaimed.

"I am sure of it," said Gordon, earnestly, —almost argumentatively. "She's an extraordinary woman."

"Keeping you good friends with me—that's a great thing. But it's nothing to her keeping you good friends with your wife."

Gordon looked at Bernard for an instant; then he fixed his eyes for some time on the fire.

"Yes, that is the greatest of all things. A man should value his wife. He should believe in her. He has taken her, and he should keep her—especially when there is a great deal of good in her. I was a great fool the other day," he went on. "I don't remember what I said. It was very weak."

"It seemed to me feeble," said Bernard. "But it is quite within a man's rights to be a fool once in a while, and you had never abused the license."

"Well, I have done it for a life-time—for a life-time." And Gordon took up his

hat. He looked into the crown of it for a moment, and then he fixed his eyes on Bernard's again. "But there is one thing I hope you won't mind my saying. I have come back to my old impression of Miss Vivian."

"Your old impression?"

And Miss Vivian's accepted lover frowned a little.

"I mean that she's not simple. She's very strange."

Bernard's frown cleared away in a sudden, almost eager smile.

"Say at once that you dislike her! That will do capitally."

Gordon shook his head, and he, too, almost smiled a little.

"It's not true. She's very wonderful. And if I did dislike her, I should struggle with it. It would never do for me to dislike your wife."

After he had gone, when the night was half over, Bernard, lying awake a while, gave a laugh in the still darkness, as this last sentence came back to him.

On the morrow he saw Blanche, for he went to see Gordon. The latter, at first, was not at home; but he had a quarter of an hour's talk with his wife, whose powers of conversation had apparently not been in the smallest degree affected by anything that had occurred.

"I hope you enjoyed your visit to London," she said. "Did you go to buy Angela a set of diamonds in Bond street? You didn't buy anything—you didn't go into a shop? Then pray what did you go for? Excuse my curiosity—it seems to me it's rather flattering. I never know anything unless I am told. I haven't any powers of observation. I noticed you went—oh, yes, I observed that very much; and I thought it very strange, under the circumstances. Your most intimate friend arrives in Paris, and you choose the next day to make a little tour! I don't like to see you treat my husband so; he would never have done it to you. And if you didn't stay for Gordon, you might have stayed for Angela. I never heard of anything so monstrous as a gentleman rushing away from the object of his affection, for no particular purpose that any one could discover, the day after she has accepted him. It was not the day after? Well, it was too soon, at any rate. Angela couldn't in the least tell me what you had gone for; she said it was for a 'change.' That was a charming reason! But she was very much ashamed of you—and so was I;

and at last we all sent Captain Lovelock after you to bring you back. You came back without him? Ah, so much the better; I suppose he is still looking for you, and, as he isn't very clever, that will occupy him for some time. We want to occupy him; we don't approve of his being so idle. However, for my own part, I am very glad you were away. I was a great deal at Mrs. Vivian's, and I shouldn't have felt nearly so much at liberty to go if I had known I should always find you there making love to Mademoiselle. It wouldn't have seemed to me discreet—I know what you are going to say—that it's the first time you ever heard of my wishing to avoid an indiscretion. It's a taste I have taken up lately—for the same reason you went to London—for a 'change.'" Here Blanche paused for an appreciable moment; and then she added: "Well, I must say, I have never seen anything so lovely as Mrs. Vivian's influence. I hope mamma won't be disappointed in it this time!"

When Bernard next saw the other two ladies, he said to them that he was surprised at the way in which clever women incurred moral responsibilities.

"We like them," said Mrs. Vivian. "We delight in them!"

"Well," said Bernard, "I wouldn't for the world have it on my conscience to have reconciled poor Gordon to Mrs. Blanche."

"You are not to say a word against Blanche, sir," Angela declared. "She's a little miracle."

"It will be all right, dear Bernard," Mrs. Vivian added, with soft authority.

"I have taken a great fancy to her," the younger lady went on.

Bernard gave a little laugh.

"Gordon is right in his ultimate opinion: you are very strange!"

"You may abuse me as much as you please; but I will never hear a word against Mrs. Gordon."

And she never would in future; though it is not recorded that Bernard availed himself in any special degree of the license offered him in conjunction with this warning.

Blanche's health within a few days had, according to her own account, taken a marvelous turn for the better; but her husband appeared still to think it proper that they should spend the winter beneath a brilliant sun, and he presently informed his friends that they had at last settled it between them that a voyage up the Nile must be for a thoroughly united couple, a very agreeable pastime. To perform this expedition advantageously they must repair to Cairo without delay, and for this reason he was sure that Bernard and Angela would easily understand their not making a point of waiting for the wedding. These happy people quite understood it. Their nuptials were to be celebrated with extreme simplicity. If, however, Gordon was not able to be present, he, in conjunction with his wife, presented Angela, as a bridal gift, with the most beautiful piece of jewelry the rue de la Paix could furnish; and on his arrival at Cairo, while he waited for his dragoman to give the signal for starting, he found time, in spite of the exactions of that large correspondence which has been more than once mentioned in the course of our narrative, to write Bernard the longest letter he had ever addressed to him. It reached him in the middle of his honeymoon.

THE END.

A MADONNA OF FRA LIPPO LIPPI.

No heavenly maid we here behold
Though round her head a ring of gold;
This baby, solemn-eyed and sweet,
Is human all from head to feet.

Together close her palms are prest
In worship of that godly guest:
But glad her heart and unafraid
While on her neck his hand is laid.

Two children happy, laughing, gay
Uphold the little child in play:
Not flying angels they, what though
Four wings from their four shoulders grow.

Fra Lippo, we have learned from thee
A lesson of humanity:
To every mother's heart forlorn,
In every house the Christ is born.

A REVOLUTIONARY CONGRESSMAN ON HORSEBACK.

THE Honorable William Ellery mounted his horse at Dighton, Massachusetts, on the twentieth of October, 1777, proposing to ride nearly five hundred miles to York, Pennsylvania, where he was to resume his Congressional duties. He had gone home in July, to attend to his private affairs; and during his absence the Congress, which then sat continuously, had been driven from Philadelphia by the approach of the British; and it was now at York, where it remained until the following year.

William Ellery was now a man of nearly fifty years of age, having been born December 22, 1727. He had been chosen to Congress in May, 1776; had signed the great Declaration; and had, as he records, stood long by the secretary to watch the bearing of his fellow-signers. In return for his patriotic service, the British troops had hastened to burn his house at Newport, on their taking possession of Rhode Island, so that his family were now residing at Dighton, Massachusetts. It was from this village, therefore, that he and his son-in-law—the Honorable Francis Dana, of Massachusetts—were to ride together to the Congress, of which both were members. Mr. Dana was the father, ten years later, of Richard Henry Dana, the poet, lately deceased, whose long career thus nearly linked the present moment with that autumnal morning when his father and grandfather mounted their horses for their journey.

It was an important time in the history of the Revolution. The first flying rumors of Burgoyne's surrender were arriving; but an interest more absorbing must have been attached, in Mr. Ellery's mind, to an expedition just organized by General Spencer to drive the British from Rhode Island. The attempt was carried so far that the Continental troops were actually embarked in boats at Tiverton, when news came that the British were already warned, and the surprise had failed. The expedition was at once abandoned, much to the dissatisfaction of Congress; but all this was not foreseen by Mr. Ellery, who, as we shall see, was anxiously listening for the sound of cannon, and hoping for a military triumph that should almost eclipse that already won over Burgoyne.

We can fancy the two worthy gentlemen, booted and spurred, wearing the full-skirted

coat, the long waistcoat, and the small-clothes of the period, and bestriding their stout horses, after due inspection of girths and saddle-bags. With Mr. Dana's manservant riding soberly behind them, they "sat out," as the diary always phrases it, on their month's journey. They were to meet the accustomed perils by field and flood; to be detained for days by storms; to test severely the larders of their hosts; to be sometimes driven from their beds by cold and wet, or from the very house through exhaustion of fire-wood—all this in time of war, moreover, near the hostile lines, and in the occasional society of stragglers from either army. Such traveling was a good school for courage, endurance and patience; it brought public men into singularly close contact with their constituents; and afforded, on the whole, a manly and invigorating experience, though one that was often comfortless to the last degree. It moreover gave perpetual opening for unexpected acquaintance and odd adventure—opportunities never wasted upon a born humorist like William Ellery. He journeyed, we may be sure, with his eyes wide open; and by no means sheltered himself behind the immunities, if such there were, of a Congressman and a "signer." Indeed, he says of himself, when he had on one occasion to seek some special privilege of travel:

"Had I announced myself a member of Congress, who would have believed me?—for, setting aside my spectacles, there is, I am sure, no dignity in my person or appearance."

This modest self-depreciation is by no means justified by Mr. Ellery's portrait; but it at least enhances the symbolic value of his spectacles, and the appropriateness of their preservation among the relics now to be seen at Independence Hall, Philadelphia.

The first and most elaborate of the traveling diaries opens as follows:

"Sat out from Dighton in Mass. Bay, in Company with the Honble Francis Dana Esq. Oct. 20th 1777 at half-past One, arrived at my good old Friend's Abraham Redwood Esq in North Providence in the Evening; and was detained there (21st) the next Day by a Storm.

"22d.—Rode to Judge Greene's (Warwick) to dine, and reached Judge Potter's, So. Kingston, in ye Evening.

"23d.—Last Night it was said Cannon were heard towards Newport. Drank Tea with Mr. Champlin whose wife was ill of a Sore Throat.

"24th.—The Weather was lowering and that and the Prospect of hearing something of the Newport Expedition detained us at Judge Potter's. This Day had a Confirmation of the glorious News of the Surrender of the Col of the Queen's Light Dragoons with his whole army. Learn hence proud Mortals the ignominious end of the vain boaster. Gave a Spur to Spencer by letter.

"25th.—The Weather still lowering and wet, abode at Judge Potter's. Saw the New London Paper which certified the News of Burgoyne's Surrender. Not a word of the Newport Expedition.

"26th.—Still dark and lowering. The Weather unfit for journeying. Good Quarters in a Storm takes off its force and renders it less disagreeable. Remained still at Judge Potter's.

"27th.—The Storm brews, the Wind increasing, and the Rain—

"28th.—The Storm tremendous. F. D. in the Course of the last Six Days hath devoured Six Quarts of Apples and Milk.

"29th.—Storm abated, but the Weather still foul and unfit for traveling—more apples and milk.

"30th.—Fair Weather. We sat off.—Judge Potter accompanied us to Mr. Marchant's, and until the Road by Mr. Marchant's meets the great Country Road to Little Rest, where we parted.—Before we sat out left a letter for General Whipple and my Wife. Dined pretty well at Brown's a private house in Hopkinton about 13 or 14 miles from Judge Potter's. After dinner rode to Tyler's which is now a private house oppsite to the Revd. — Hart's Meeting House, drank a Dish of Coffee in the Evening and were waited upon by a good female Body, who was almost consumed with the Hysterics of Religion—*vide* Dr. Lardner's Credibility of the Gospel History."

In spite of this disrespectful reference to religious hysterics, it seems that our travelers did not proceed upon their journey on Sunday.

"We spent the Sabbath at Hartford. In the afternoon heard Mr. Strong preach a good Sermon, and most melodious Singing. The Psalmody was performed in all its Parts, and Softness more than Loudness seemed to be the Aim of the Performers. In the Evening waited upon Gov. Trumbull and was pleased to find so much Quickness of apprehension in so old a Gentleman. Connecticut have collected, and ordered Taxes to the Amount of One hundred thousand Pounds more than they had issued. Brave Spirits!"

Governor Trumbull was revered as the only colonial governor who took the patriotic side; and is also likely to be held in permanent fame as the author of the phrase "Brother Jonathan." He was at this time but sixty seven; yet that may have seemed an advanced age to William Ellery, at fifty, since the latter could not have foreseen that he himself should live to be ninety-two, and should retain his "quickness of apprehension" to the last. After this burst of enthusiasm we are soon brought back to the question of the larder, always so important on a horseback journey.

"Nov. 3d.—Left Hartford and bated at Farmington, at Lewis' about 12 miles from Hartford; from thence rode to Yale's 12 miles, where Mr. F. D. dined on Three Pints of Milk and Cake lightened with Scraps, and W. E. dined on Bread and Milk Punch.—From thence rode through Herrington over the worst road I ever passed to Litchfield, where we lodged with Genl. Wolcott, and were kindly entertained. He had lately returned from the Northern Army, where he commanded a Number (300 I think) of Volunteers, which he had collected by his Influence. He gave us an account of the Surrender of the menacing Meteor, which after a most portentous Clare had evaporated into Smoke (Gov. Livingston's Speech to the Assembly, Fishkill Papers, Sept. 4th) and gave it as his Opinion that the Army under Genl. Gates at the Time of ye Capitulation did not exceed 12,000 men."

Coming nearer the seat of war, our travelers felt its discomforts; first, in the ruinous condition of the bridges, and then in the presence of troops and in nocturnal alarms. The following extracts show these annoyances:

"Nov. 4th.—Left Litchfield about nine o'clock. * * * The Bridges along this road from Hartford are some of them entirely destroyed, and all of them out of repair, owing to the constant passing of heavy loaded wagons and the late heavy storm. On our way to Flower's we passed over Chepaug a long, crazy Bridge, and between Flower's and Camp's over Housatonick Bridge, which was held together by a few Wedges.—After we left Chepaug Bridge the Road to Camp's was good.

"Nov. 5th.—Rode to Danbury where we breakfasted at a private house, after having visited every Inn for Accomodations but in vain; some were crowded with Soldiers, and others void of every necessary article of Entertainment. Danbury is eleven miles from Camp's. We intended when we left Litchfield to have gone to Peekskill, and there to have crossed the North River; but, when we got to Danbury, were dissuaded from it by the Person at whose house we breakfasted; who told us that there were Tories and Horse-stealers on that Road. This account and it being late in the forenoon that it was impossible to reach Peekskill by Night, and not being able to procure a Lodging in Danbury, occasioned us to take the Fishkill Road; Accordingly we sat off, bated at the Foot of Quaker Hill, about 7 miles from Danbury, and reached Col. Ludinton's, 8 miles from the foregoing stage, at night. Here *mens meminisse horret!* We were told by our landlady the Colonel was gone to New Windsor, that there was a Guard on the Road between Fishkill and Peekskill, that one of the Guard had been killed about six miles off, and that a man not long before had been shot at on the Road to Fishkill, not more than 3 miles from their house; and that a Guard had been placed there for some time past and had been dismissed only three days. We were now in a doleful pickle, not a male in the house but Don Quixote and his man Sancho and poor Pill Garlick,* and no Lodging for the first and

* Mr. Ellery gives the names of Don Quixote and Sancho to Judge Dana and his servant; and employs the name "Pill Garlick" or "Pillarlick" for himself. This last word has now passed out of use, but it is often employed in books of the last century as a substitute for the first person singular, especially in case of a lonely person or one growing old. Several derivations have been assigned for it; these may be found in Grose's Dictionary and Brewer's "Phrase and Fable."

last but in a lower room without any Shutters to the windows, or Locks to the Doors.—What was to be done? What could be done? In the first place we fortified our Stomachs with Beefsteak and Grogg, and then went to work to fortify ourselves against an attack.—The Knight of the woeful Countenance asked whether there were any Guns in the house. Two were produced. One of them in good order. Nails were fixed over the windows, the Guns placed in a corner of the room, a pistol under each of our pillows, and the Hanger against the bed-post; thus accoutred and prepared at all points, our heroes went to bed.—Whether the valiant knight slept a wink or not, Pill Garlick cannot say; for he was so overcome with fatigue and his animal Spirits were so solaced with the beef and Grogg, that every trace of fear was utterly erased from his imagination, and he slept soundly from Evening till Morning without any interruption, save that about midnight, as he fancieth, he was waked by his Companion with this interesting Question delivered with a tremulous voice: ‘What noise is that?’ He listened and soon discovered that the noise was occasioned by some rats gnawing the head of a bread-cask. After satisfying the Knight about the noise, He took his second and finishing nap.”

The next day it snowed. The fire-wood at this house gave out, and they were forced to ride five miles in the storm to the next stopping-place. Then follows a picture of a rustic “interior,” as quaint and homely, and almost as remote from the present New England, as if painted by Wilkie or Van Ostade:

“We were ushered into a room where there was a good fire, drank a dish of Tea, and were entertained during great part of the Evening, with the Music of the Spinning-wheel and wool-cards, and the sound of the shoemaker’s hammer; for Adriance had his shoemaker’s bench, his wife her great wheel and their girl her wool-card in the room where we sat. This might be disagreeable to your delicate macaroni gentry; but by elevating our voices a little, we could and did keep up conversation amidst the music; and the reflection on the advantages resulting from Manufactures, joined to the good-nature of our landlord and his wife, made the evening pass off very agreeably.”

The next extract gives us a glimpse of John Hancock, who had just resigned the presidency of Congress and was on his way home:

“Nov. 7th.—Breakfasted at Adriance’s, and sat off for Fishkill where we arrived at noon. Could get no provender for our horses, but at the Contl [Continental, i. e. military] Stables. Waited upon Gen. Putnam who was packing up and just about setting off for White Plains. Chatted with him a while, and then put off for the Contl Ferry at the North River. (Fishkill is eleven miles from Adriance’s and the Ferry six miles from Fishkill.) In our way to the Ferry we met President Hancock in a sulkey, escorted by one of his Secretaries and two or three other gentlemen, and one Light-horseman. This escort surprised us as it seemed inadequate to the purpose either of defence or parade. But our surprise was not of long continuance; for

we had not rode far before we met six or eight Light-horse-men on the canter, and just as we reached the Ferry a boat arrived with many more. These with the Light-horse-men and the gentlemen before mentioned made up the escort of Mr. President Hancock.—Who would not be a great man? I verily believe that the President, as he passed through the Country thus escorted, feels a more triumphant satisfaction than the Col. of the Queen’s Regiment of Light Dragoons attended by his whole army and an escort of a thousand Militia. We had a pleasant time across the Ferry, and jogged on to Major Dubois a Tavern about 9 or 10 miles from thence, where we put up for the night. We were well entertained, had a good dish of tea, and a good beef-steak. We had neither ate or drank before since we breakfasted. Dr. Cutter invited us to dine with him at Fishkill; but it was not then dinner time and we were anxious to pass Hudson and get on.”

This allusion to Burgoyne is, of course, a sarcasm, the thousand militia-men being the Continental troops that escorted his army to its place of detention at Cambridge, Massachusetts. The next glimpse must be of the Moravian settlement at Bethlehem, Pennsylvania,—a haven of luxurious comfort to the unfortunate travelers of those days:

“Nov. 10th.—Breakfasted at Carr’s, and rode 12 miles to Easton, where we baited. We passed the Delaware with Genl Fermoy without making ourselves known to him. From Easton we rode in the Rain to Bethlehem for the sake of good accommodation, and were invited by Mr. Edwine one of the Ministers of the Moravian Society who had been so kind as to show me the public buildings when I was at Bethlehem the last June. When Congress were here in their way to York; they ordered that the House of the single women should not be occupied by the Soldiery or in any way put to the use of the Army; and that as little disturbance as possible should be given to this peaceful Society, which Mr. Edwine took notice of with great gratitude.—A number of sick and wounded were here,* a considerable quantity of baggage and Guards;—and a number of Light-horse were at Nazareth, feeding on the hay and grain of the Society, which I found was disagreeable; but at the same time perceived that they did not choose to complain much lest their complaints should be thought to proceed not so much from their sufferings as from a dislike to the American Cause. This people, like the Quakers are principled against bearing Arms; but are unlike them in this respect, they are not against paying such taxes as Government may order them to pay towards carrying on War, and do not I believe, in a sly underhand way aid and assist the Enemy while they cry Peace, Peace, as the manner of some Quakers is, not to impeach the whole body of them.

Nov. 11th.—Continued at Bethlehem, the weather

* One of these invalids was Lafayette, who was wounded at the battle of Brandywine, Sept. 11, and was taken to Bethlehem in the carriage of Henry Laurens on the removal of Congress. Pulaski afterward visited Lafayette at Bethlehem, and was subsequently presented with a banner by the Moravian sisterhood,—an incident well known through an early poem by Longfellow.

being very cold and the wind high, and our horses wanting rest, and to have their shoes repaired. Fared exceedingly well, drank excellent Madeira, and fine green tea, and ate a variety of well-cooked food of a good quality and lodged well.

Nov. 12th.—Baited at Snell's 9 miles, and ate a tolerable veal cutlet. Snell is a good Whig.

Then comes another picture of the discomforts of a late autumnal journey :

"Nov. 12th.—The fore part of this day was filled with snow squalls, which proved peculiarly irksome to Mr. Dana's servant, whose Surtout was stolen from him the eve'ng before at Johnston's by some Soldier. The afternoon was comfortable but the eve'ng was windy and exceedingly cold. The room in which we sat and lodged admitted the cold air at a thousand chinks, and our narrow bed had on it only a thin rug and one sheet. We went to bed almost completely dressed, but even that would not do. It was so cold that I could not sleep. What would I not have given to have been by my fire-side. I wished a thousand times that the Old-Fellow had our landlady. Our fellow lodgers suffered as much as we did, and if they had read Tristram Shandy's chapter of curses, and had remembered it would have cursed her through his whole catalogue of curses. What added to the infamouslyness of this Tavern was the extreme squalidity of the room, beds, and every utensil. I will conclude my story of this Sink of Filth and Abomination with a circumstance which, while it shows that our dirty landlady had some idea of neatness, must excite a contemptuous smile.—The table on which we were to breakfast was so inexpressibly nasty that we begged she would put a clean napkin on it, to which this *simplex munditiis* objected that the coffee might dirty the cloth.—I intended to have finished here; but the avarice of this Mass of Filth was as great as her sluttishness,—was so great that I cannot forbear noticing it. Notwithstanding we had nothing of her but a bit of a Hock of pork, boiled a second time, and some bread and butter (we found our own tea and coffee) and hay and oats for our horses; this Daughter of Lycurgus charged for Mr. Dana, myself and servant, thirty-eight shillings lawful money."

The next day Mr. Ellery met other eminent men, following in the steps of Hancock. The main work of the session being through, and military operations being almost closed by the approach of winter, Samuel Adams had for the first time received leave of absence from Congress, while John Adams had been appointed commissioner to France; and they journeyed homeward together:

"Nov. 13th.—Met Mr. Samuel and Mr. John Adams about 9 miles from Levan's, and hard by a tavern.—They turned back to the Inn, where we chatted, and ate bread and butter together. They were to my great sorrow bound home. I could not but lament that Congress should be without their councils, and myself without their conversation."

It is rather tantalizing that these few lines should be the only record of this memorable chatting over bread and butter,

while so much more space is immediately given to one of those Fielding-like adventures which the gravest Congressman might then encounter on his travels :

"We reached Reading where we put up at one Hartman's near the Court House, in the middle of the afternoon. It was with great difficulty that we could get a lodging. We were obliged to lodge in a room with a curious crazy genius. We went to bed about nine O'clock; about half-past ten in came the Genius thundering. He stamped across the room several times, and then vociferated for the boot-jack. He pulled off his boots, hummed over a tune, lighted up his pipe, smoked a few whiffs, took his pen and ink and began to write, when there was a keen rapping at our chamber door. He turned his head toward the door and was silent. Immediately the door was forced open, and such a scene presented as would have intimidated any person of less heroism than F. D. and W. E. In rushed a Sergeant's Guard with fixed bayonets and arrested the Genius. All was confusion. There was 'Damn your blood Sir, what do you mean?' 'I arrest you sir; seize his papers.' 'Genl Mifflin'—'War-rant'—'Challenge'—'Let me put on my clothes. I'll go with you to Genl Mifflin'—'You shall go to a house twenty times as good for you. I'll take care of you.' After some time we found out that our cracked Genius had challenged Genl Mifflin, and therefore was arrested. They took him away, but he had not been gone long, before he returned to the House cursing and swearing, and was locked up in another Chamber. Two officers who were in bed in that chamber were obliged to decamp to make way for him and took his bed in our room."

"The knight of redoubted valor, had at his return got up, dressed himself, and told the officer of the Guard, that he had put the Genius into a passion, and that he must not be put into our room to disturb us, which occasioned his quarters being shifted. The two officers before mentioned told us that the Genius when he was enraged as he then was, was a ferocious creature and that we might expect that he would attempt to recover his old lodging before morning.—The landlady her daughter and maids were all roused and had got up; the landlord and Pill-Garlick kept snug in bed; all the females and the Knight were busily employed half an hour in putting the lock of our door in order. When that was effected the Knight put his pistols under his head, his hanger in the chair near the bed, and then came to bed. In the morning early the Genius rose, strutted about his prison and hummed over a tune in seeming good humor.—After some time he was discharged, came into our room, asked our pardon for the disturbance he had occasioned and offered us some of his loaf sugar to sweeten our tea. He then waited on Genl Mifflin, returned and said he was a clever fellow, but swore damn him that he would go and kill the Officer of the Guard if he could find him. Out he went, but what became of him I know not; for we set off, but I believe he killed nobody."

But the journey of our Congressman is fast drawing to a close, and soon ends as follows :

"Nov. 14th.—Crossed the Schuylkill dined at Miller's near the town of Ephrata *al. dic.* [*alii dicunt* = *alias*] Dunkard's Town and lodged at Letidz a little Moravian Settlement, where we lodged in Clover.

We lodged in Cabins about 3 feet wide, a straw bed was at the bottom, a feather bed on that, sheets, a thin soft feather bed supplied the place of blankets, and a neat calico coverlid covered all; and our lodging room was kept warm during the night by a neat earthen stove which in form resembled a case of Drawers.

"Nov. 15th.—Crossed Anderson's Ferry which is 17 miles from Letidz about noon, and in the afternoon reached Yorktown which is 10 miles from the Ferry, and so finished our Journey of four hundred and fifty miles."

In June, 1778, Mr. Ellery records another horseback journey. Congress had left Yorktown and returned to Philadelphia, just evacuated by the British; and this was the appearance of the country on the way:

"From Derby to Schuylkill the Fencing was destroyed and the fields lay entirely open; but as the stock had been removed by the Owners or taken by the enemy, the grass was luxuriant.—As I passed the Schuylkill the naked Chimnies of destroyed houses on my left expressed in emphatic language the barbarity of the British officers & Soldiery. The city however was in a much better state than I expected to have found it. At Chester heard the glorious news of the defeat of Genl Clinton at Monmouth. I lodged at Philadelphia with my friend William Redwood and continued in Philadelphia until the 10th of July when I sat out for Dighton in company with him. On the glorious fourth of July I celebrated in the city Tavern with my brother delegates of Congress and a number of other gentlemen amounting in the whole to about 80, the anniversary of Independency."

His description of this entertainment was quoted in this magazine for July, 1876, in an article entitled "The Story of the Signing."

He went from home to his Congressional duties that same autumn, leaving Dighton October 24, 1778. The opening of his diary on this occasion shows amusingly some of the inconveniences to be surmounted before setting off:

"Sat out from Dighton on a Journey to Philadelphia, arrived at Providence in the afternoon. The black man who had engaged to attend me on the Journey fell sick or pretended to be so. I sent an express to Dighton for a boy with whom I had talked about his going and had refused to take on account of this same black man. The Boy was now unwilling to go. I applied to Genl Sullivan who accommodated me with a Soldier of Jackson's regiment. The black fellow was a married man and alas and lack-a-day was under petticoat government and his sovereign wanted to keep him at home to wait upon her. If I had known previous to my engaging him that he had been under this kind of domination I should have consulted his Domina and procured her consent, before I had depended upon him, and not suffered this sad disappointment. Well—let the ambitious say what they please, Women have more to do with the government of this world than they are willing to allow. Oh! Eve—Eve!"

A little farther on we come to the more substantial discomfort of a storm, putting a stop to all travel, and giving opportunity for genial philosophizing by the fireside:

"Oct. 31st.—We were at Emmons' detained by a storm which has been brewing for more than a fortnight; but which, to our comfort, is like the dram which the Gentleman presented to the Rev^d Dr. Phillips of Long Island, the least, as he said, by the dram that ever I saw of its age in my life. This Mr. Phillips had been preaching in I know not and care not what Parish, and being much fatigued the Gent. with whom he dined, to refresh his spirits before dinner, presented him with a dram in a very small glass, observing at the same time that the dram was 10 years old. The arch priest wittily professed that it was the least of its age that he had ever seen in his life.—But as small as the storm is, it is large enough to detain us.—Mrs. Emmons our Landlady, is one of the most laughing creatures that ever I saw. She begins and ends everything she says, and she talks as much as most females, with a laugh which is in truth the silliest laugh that ever I heard.—As man hath been defined as a laughing animal as Laughter manifests a good disposition and tends to make one fat, I will not find fault with laughing, let Solomon & Chesterfield have said what they may have said agst it. Indeed the former says there is a time to laugh, but with the latter it is at no time admissible. However, Chesterfield when he condemns it hath the character of a courtier only in Idea, and does not regard common life. And Horace I think says, *Ride si sapiis*.—The Spectator hath divided laughter into several species some of which he censures roundly; but doth not as I remember condemn seasonable, gentle laughter.—Therefore my pleasant Landlady, laugh on."

A little later he finds another landlady, as kind but less cheerful; and we have a glimpse at the standard of comfort then prevailing in Connecticut:

"Nov. 1st.—Passed Connecticut River and dined at Chidsey's on the middle road on the east skirt of Durham. Our Landlady was very kind and pleasant. Her cheese and butter were excellent; but alas! They had no Cyder; and in consequence of it she said with the tone of lamentation, that they should be quite lonesome this winter. The good people of Connecticut when they form the semicircle round the warm hearth, and the Tankard sparkles with Cyder, are as merry and as sociable as New Yorkers are when they tipple the mantling Madeira."

Then follows another graphic picture of a way-side interior:

"Nov. 5th.—Took the route through Paramus and breakfasted at a Dutchman's about 7 miles from Coes, and were well entertained. A little diverting affair took place here. The Children who had never before seen a Gentleman with a wig on, were it seems not a little puzzled with my friend's head-dress. They thought it was his natural hair, but it differed so much from mine and theirs in its shape that they did not know what to make of it. The little boy after viewing it some time with a curious eye asked his mother, in dutch, whether it would hurt my friend if he should pull his hair. The mother told

us what the boy had said; whereupon my friend took off his wig, put it on the head of the boy and led him to the looking-glass. The mixture of Joy and Astonishment in the boy's countenance on this occasion diverted us not a little. He would look with astonishment at Mr. Redwood's bare head, and then survey his own head, and the droll figure he made with the wig on made him and us laugh very heartily. It is not a little remarkable that children who had lived on a public road should have never before seen a wig."

That night he reaches Elizabethtown, N. J., where we have a glimpse at some of the mild relaxations of the Continental army:

"We lodged at one Smiths. A Detachment of the Army, under Lt. Stirling was here. The officers had a ball at Smiths, and kept up the dance 'till three o'clock in the morning. Drum, fife and fiddle, with an almost incessant saltation drove Morpheus from my Pillow."

"Lord Stirling" was General William Alexander, who had been an unsuccessful claimant for the earldom of Stirling. Later we are presented with some of the joys of travel, tempered with pensive moralizing:

"Nov. 9th.—We breakfasted at Gilchrist's in Woodbury. In the way from Roxbury to Woodbury, about three or four miles from the former, the Eye is saluted with a beautiful Landscape. The side of a mountain in a semicircular form, from its gentle declivity presents a charming variety of fields and woods and buildings. In a word it yields a more beautiful prospect than any you behold between it and Philadelphia—Gilchrist furnished us with the best dish of Bohea Tea and the best toasted bread and butter I have eaten for a twelvemonth. But this is a chequered state of things, and good alas! is frequently attended with evil. My Surtout * * * * *

There seems to have been some farther tragedy in respect to this overcoat. Perhaps it had followed the garment of Mr. Dana's servant into the patriotic army. The next day brings us close to the enemy's lines:

"Nov. 10th.—Breakfasted at Buells in Hebron eight miles from Hills—Dined at Jesse Billings, my Tenant in Colchester. The Enemy on Monday entered N. Haven and pillaged the Inhabitants. They were opposed by a handful of men who behaved gallantly. Of them between twenty and thirty were killed, and of the enemy it is said an equal number, and among them was an Adjutant Campbell. The next day they landed at Fairfield and burned the Town.—How they came to destroy this town and not New Haven is matter of inquiry. They are now, it is said, hovering about New London, a considerable body of militia is collected there, and more men are ordered in. Some Gentlemen of Hartford seemed to be apprehensive that the enemy would pay them a visit. I wish they might. For I presume such a body of men would muster on that occasion as would effectually prevent their return. It is thought that they mean to draw off the main army from their present post, and then to attack West Point Fort. I rather think that their intention is to keep the People in constant alarm,

and thereby prevent their getting in the Summer harvest. Finding that they cannot conquer the country, they are determined agreeably to the Manifesto of the Comms., to do as much mischief as they can to make our alliance with France of as little benefit to that Kingdom as possible.—Miserable Politicians! by their infernal conduct they will destroy every spark of affection which may still remain in the breast of Americans, and force us and our commerce irrevocably into the Arms of France, which have been and still are extended to receive both. *Quos Deus vult perdere prius dementat.*—We were detained by the rain at Mr. Billings the afternoon, and lodged there."

Yet amidst all these public cares our worthy statesman found time to notice not merely mankind but womankind, on the way; now noticing that his landlady "hath an Austrian lip," and now wondering, as the less ornamental sex was wont even then to wonder, over the freaks of fashionable costume,—thus:

"Nov. 12th.—Bated at Adam's about 8 miles from Lathrops; where I saw a Girl whose head-dress was a fine Burlesque on the modern head-dress of polite ladies. It was of an elevated height and curiously decorated with Holyokes [hollyhocks]. Lodged well at Dorrances."

On the 14th, he reaches Dighton, and thus sums up his journey:

"Reached home at dinner time, 18 miles from Providence and found all well. This Journey for the season was exceedingly pleasant. The first four days were too hot for comfort; but the succeeding six were cool, and my mare was as fresh when I got home as when I sat off. The two men who escorted me and a sum of Money for the State behaved very well, and my Companion was sociable and clever."

Three more of these diaries of travel, making five in all, are preserved by the descendants of Mr. Ellery. They were consulted by Professor Edward T. Channing when preparing the memoir of his grandfather, published some forty years ago, in the sixth volume of Sparks's "American Biography." He gives some extracts from them, but these are marred by a peculiarity of editing not uncommon among American literary men of the last generation,—an exaggerated sense of decorum which led even the accurate Sparks to substitute "General Putnam" for the more familiar "Old Put" in Washington's letter; and led Professor Channing to strike out, from one passage I have quoted, all reference to Don Quixote and Pilgrallick, and to offer the reader a vague collation of "beef-steak and strong drink" for the terser bill of fare, "Beef-steaks and grogg." The theory of both these excellent biographers was, no doubt, that they should

amend the *déshabille* in the style of these familiar epistles and put on them a proper walking-dress before sending them out to take the air—as the writers themselves would have done, had they foreseen this publicity of print. This may often be a good argument for omission, but it can never be an argument for alteration; and I think writers of the present day have a stricter sense of the literal significance of a quotation-mark.

It may interest the reader to be told, in conclusion, that William Ellery long outlived the fatigues and dangers of the Revolution and passed an eminently peaceful and honored old age. He left Congress in 1785, and could then return to his native town; but his house was burned, his mercantile business was destroyed, the town itself was almost ruined, and he had, when almost at the age of sixty, to begin life anew. During the following year, Congress appointed him commissioner of the Continental Loan Office for Rhode Island, and on the adoption of the Federal constitution by that state, in 1790, he became collector of customs for the Newport district,—an office which he retained until his death. He

lived to see one of his grandchildren, William Ellery Channing, the most noted clergyman of Boston; another, Walter Channing, the first resident physician of the Massachusetts General Hospital; and two others, Edward T. Channing and Richard H. Dana, the joint editors of the "North American Review," a periodical then new-born, which Mr. Ellery must have read with delight. To these his descendants, and to all the young people who constituted their circle, his personal society is said to have been a constant joy. "He was not their teacher," says one of them, "but their elder companion." He retained his intellectual faculties unimpaired until the very last hour, and died February 15, 1820, at the great age of ninety-two. On the morning of his death he rose and partly dressed himself, then lay down from weakness, and the physician found his pulse almost gone. Wine revived him, and the doctor said, "Your pulse beats very well." "Charmingly!" said the courageous old man; after which he lay for some two hours in silence,—saying once only that he knew he was dying,—and then ceased to breathe.

THE SPIDER'S LESSON.

A TYRANT in my border dwells
In Austrian black and gold;
Wrought all in silver are his cells,
Fine-spun, a thousand fold.

His dwelling has no dingy roof,
Nor dismal underground;
The sunlight gilds its slender woof
On fragrant bushes bound.

And at his levée, every morn,
Such brilliants do appear
As ne'er in any court were worn
By Christian monarch dear.

No prison dungeon has this wretch
Where victims, out of sight,
His cruel jealousy may fetch
And keep in hopeless night.

Yet subtle stratagems he springs
On harmless passers-by,
Winds his soft silk about their wings,
And hangs them up to die.

I came to sweep his work away
With swift, impatient hand;
But here the lesson of the day
He teaches, as I stand.

The tyrant Luxury doth so
Our wingèd souls entwine,
And binds us fettered in a show,
To mock the free sunshine.

The subtle web afar I'll leave
Of flattering deceit;
The gorgeous spider shall not weave
His fetters for my feet.

The eye that views the heavens in faith,
The hand with justice armed,
Can see the snare that binds to death,
And scatter it, unharmed.

EXTRACTS FROM THE JOURNAL OF HENRY J. RAYMOND. II.

(EDITED BY HIS SON.)

WITH THE ARMY OF THE POTOMAC IN 1863.

THE ten years from 1852 to 1862 were among the busiest of my father's life, and during that time the old Index Rerum did not receive a single addition under the head of memoranda. In this respect, it was somewhat like the portals of the temple of Janus,—closed in peace and reopened in war. My father was often urged to take active part in the contest for national unity, which had begun when the next entries in his diary were made. At a time when political generals were much in fashion, he had been offered high rank in the military service. He felt, however, that he had more important work to do in his own sphere,—to help keep up the spirits and the courage of the North, to fight the opposition element at home, and to strengthen the Government by the active support of "The Times." Moreover, having no military knowledge or experience, he shrank from assuming the command, and perhaps the disposal of the lives of thousands of his fellow men. He was twice drafted, and each time furnished a substitute.

Speaking of his lack of military experience, he used to say that he had about as much knowledge of military science as a relative of his, who, at the breaking out of the war, went to the Secretary of War, and said that he wanted a colonel's commission. The Secretary made some general remarks, and finally asked him if he had had any military experience. "Yes, sir," he answered; "I've been to general training once, and in the guard-house twice." He got his commission, and raised, equipped, and satisfactorily commanded the First Vermont Cavalry.

Notwithstanding his lack of military experience, my father had been with a contending army previous to the beginning of our civil war, and had witnessed actual warfare on the bloody fields of Montebello and Solferino with the staff of the French emperor. During our civil war, he was often in the camps and on battle-fields.

The extracts which follow are taken from memoranda made soon after the disastrous events which occurred while the Army of the Potomac was maneuvering in front of Fredericksburg, Virginia, during the mem-

orable winter of 1862 and 1863. General Burnside had succeeded to the command of the army, November 7th, 1862, and on the 15th of that month, being then at Warrenton, he turned the army toward Fredericksburg, marching along the north bank of the Rappahannock, and intending to cross the river, occupy Fredericksburg, and advance upon Richmond from that point. This movement was followed by the ineffectual attempts to effect a permanent landing on the south side of the Rappahannock, opposite the town, which were made on the 10th, 11th, 12th, and 13th of December, 1862. On the night of the 15th, the army was withdrawn to the north bank of the river, to the great disappointment of the country, which was impatient at delay, and greatly excited over the failure of the movement. The army remained quiet until January of the following year. In the meantime, my father had gone to the head-quarters, and the result of his observations is recorded in the subjoined extracts, which shed new light on the stirring incidents of this much-discussed campaign:

"January, 1863.—On Thursday, January 15th, I received at dinner a telegram from Colonel Swain at Washington, 'Your brother's corpse is at Belle Plaine. Come immediately.' Knowing that my brother had been sick, I made no doubt of the truth of the message, and at seven the next morning started for Washington. I arrived in the evening, and, failing to see Colonel Swain, started the next day at eight for Belle Plaine. It was a very cold day, the boat was crowded with convalescent soldiers from the hospitals at Washington, and everything conspired with the melancholy nature of my errand to make the journey one of great discomfort. Dr. Willard of Albany went with me as far as Acquia Creek, where I took another boat, and found as one of my *compagnons de voyage* Dr. Dean, also of Albany, who had entered upon the business of embalming the dead of the army. I made all necessary inquiries and arrangements in regard to my brother, landed at Belle Plaine, and made fruitless inquiries for his body. I finally walked to the head-quarters of General Wadsworth, in whose division was the brigade to which my brother's regiment belonged. He received me with great kindness, and got some dinner for me, while he sent one of his aids, Colonel Cress, to make inquiries into the circumstances of my brother's death. While seated at dinner, the aid returned, and my brother with him! I had the pleasure of his company during the remainder of my dinner. As he knew nothing of my errand, I puzzled him a good deal by telling him that his

appetite was much better than I had expected to find it, etc. I finally told him the message which had brought me down. He was a good deal taken aback, but said he would forgive the blunder, inasmuch as it had secured a visit from me. It turned out afterward that Colonel Swain had sent a message that my brother's *corps* was at Belle Plaine, and he wished me to come immediately, as he was about to send a boat directly to that place.

"I spent the night with General Wadsworth, and learned from him that orders had been received from head-quarters to be ready for a march at an hour's notice. Understanding from this that a new movement against the enemy was on foot, I resolved to prolong my stay. General Wadsworth thought the reported demoralization of the army was very much exaggerated, and that the only trouble was in the disaffection of some of the officers, who had been greatly favored by McClellan, and were hoping for his return to the chief command. However, he said he had been so much censured the year before for his free speaking concerning the officers, that he had resolved to hold his tongue for the future. * * * His quarters were not especially comfortable, and it was easy to see on the one hand that he had very little experience in taking care of himself, and on the other that he allowed servants to take very little care of him. He had a small stove in his tent, the door of which was constantly falling from its hinges whenever he attempted to replenish the fire. Instead of having a servant to attend to this, he did it himself; and, instead of having a holder, he invariably poured water upon the door until it was cool enough for handling. I spoke to him of his lack of luxury in his style of living, when he made answer that he thought it best to give his subordinate officers an example of plain living while in camp. I doubt whether this has as much effect upon troops as is often supposed. I am inclined to think that privates even like to see their commanding officers surrounded by something of the ostentation that befits their rank. Judging from his conversation on business matters with his aids, General Wadsworth seemed to me to have but little practical acquaintance with the details of his command. He complained somewhat of not being more closely connected with head-quarters, where his general sentiments and interest in the war could be brought to bear more directly upon the councils of the campaign.

"The next day (Sunday) I walked over to the Twenty-fourth Michigan Regiment. They were very comfortably housed in huts, and were anticipating the order to move with a good deal of apprehension. Their experience of long marches through heavy rains, and of bivouacs on the cold wet ground, had given special zest to the comparative comfort they were then enjoying. I dined with Colonel Morrow of this regiment,—a frank, clear-headed gentleman, formerly a lawyer and judge in Detroit. He said there was a good deal of dissatisfaction—or, rather, of despondency—among the officers and men, due mainly, in his opinion, to a lack of military successes and to a want of confidence in General Burnside. I asked him why they lacked confidence in him. He replied, because he had no confidence in himself; he had said more than once that he did not feel competent to command that army. I spoke of this as only the natural modesty of a truly capable man. Yes, he said, that was true; but he (General B.) had not only *spoken* of his incompetency, but had gone before the Congressional Committee and *sworn* to it. As an instance of the feeling among his officers, he said that

one of his lieutenants had recently sent in his resignation, based on the fact that he did not approve of the policy on which the Government was now conducting the war! Colonel Morrow thought a reorganization of the army important to its usefulness, and said he believed the best course would be to put at its head some general who had never been mixed up with its quarrels and rivalries, in whom all would have confidence, and who should bring with him the prestige of success. General Rosecrans seemed to answer this description better than any other man.

"Toward night, General Wadsworth, having given me a horse and an orderly, I rode about eight miles to General Burnside's head-quarters. He received me with great cordiality, and made me at once at home. He told me he would be glad to have me mess with him, and that I should sleep in the tent of Lieutenant Goddard, one of his aids. He told me of the orders he had issued for the march of the army the next day, intending to make an attack upon the enemy across the river early on Tuesday morning. General Pleasanton, of the cavalry, however, had reported that during the preceding night he had heard the rumbling of artillery on the opposite side, and other indications that the enemy was massing troops above Fredericksburg. This led the General to suppose that the enemy might have discovered his plan, which was to deceive them by feints into the belief that he intended to cross ten miles below the city, and then make the actual crossing eight miles above, at Bank's Ford. In order to render himself certain on this point, he postponed the movement a day, and sent a trusty spy, named McGhee, to ascertain the movements of the enemy.

"The General told me the manner in which this spy conducted his operations. The rebels had pickets only at the places where crossing was feasible; there were many others where the high, steep banks on either side rendered it impossible. McGhee's habit was to let himself down the bank by a rope at one of these points, cross on a raft which he kept concealed in the bushes, and communicate with one of several Union residents on the other side. On this occasion he spent nearly the whole day waiting for an old man who lived within the rebel lines to traverse the neighborhood in his farm-wagon and ascertain the facts. Toward night, he brought a letter from this man,—a wretched scrawl, badly spelled, and evidently from a very ignorant person, but containing the important information that the enemy had sent one brigade considerably above Bank's Ford to provide against a crossing at the United States Ford, but that there were no troops or guns at the former place. This was all that General Burnside wished to know, and he forthwith proceeded to put his plan in execution.

"On Monday evening, as we were sitting round the table after dinner, we heard the strains of a fine band of music in front of the General's tent, and an officer soon announced that Generals Franklin and Smith had called to see the commander. I at once withdrew to Lieutenant Goddard's tent, and, after reading awhile, went to bed, meantime having heard a good deal of loud talking in the General's quarters.

"The next morning (Tuesday) the General asked me to take a promenade with him. As we were walking, he told me that he found it extremely difficult to carry any operations into effect for lack of cooperation among his officers. Generals Franklin and Smith, he said, had spent the whole of the preceding evening in remonstrating and protesting against the projected movement. They had said everything in their power to show that it must prove

a failure. They thought any movement now would be fatal. The enemy were too strong, and our own troops were not in a fighting mood. They had no confidence in success, and General Franklin said the New Jersey troops in his division had been greatly disinclined to fight by reason of the election to the United States Senate of Wall (an open secessionist recently released from Fort Lafayette), which they cited as proving that their State was opposed to the war. General Burnside said they were so violent in their opposition, and apparently so determined in their hostility to the movement, that, if he had forty-eight hours more of time, he would relieve them from their commands and put others in their places. He said he told them he had weighed all their objections, had examined the ground personally and with great care, and had decided upon the movement as feasible. He should put them across the river on Wednesday morning, and leave with them the responsibility for the conduct of their commands. They left head-quarters at about eleven.

"Orders were issued that night for the movement of the troops next day, to be in position for operations on Wednesday morning. At six o'clock on that day, batteries were to open upon the enemy at Skinner's Neck, *below* Fredericksburg, as if covering a movement there. At seven, four pontoon bridges were to be thrown across the river at Bank's Ford, above the city. Hooker's division was to cross first, and occupy one designated range of heights, and Franklin's was to follow and hold another. These two positions, which were not defended by the enemy, would command them completely and give us access to their rear.

"When I first came over to head-quarters, in the course of conversation I had told the General of the resignation of the Michigan lieutenant. He at once sent for the paper and for the officer, and on Monday, while I was sitting in his tent, they were brought in. The General read the resignation carefully, and then turned to the officer. He asked him sundry questions, found that his name was ———, from Detroit, and then upbraided him in terms of great severity, for his cowardly and mutinous conduct. What right had he to sit in judgment on the policy of the Government? Suppose every officer were to do the same, what would become of the army? He ended by telling him that he should dismiss him in disgrace for cowardice and disloyalty, and that, if he should live to the age of Methusaleh, he could never efface the brand. He then ordered him under arrest, and sent him on board the guardship. My brother afterward told me that he was not a bad fellow, but that he had become tired of the war, and desperate in his eagerness to go home upon hearing of the death of his child and the dangerous illness of his wife. General Burnside's manner was very vigorous, and the rebuke, coming as it did from an earnest and sincere mind, was very effective.

"The night of Monday was clear and the weather moderate. By morning it had become cloudy, and a cold north-east wind seemed to threaten rain or snow. The movement of the troops began about 10 o'clock, and throughout the day they continued to pass along the road back from the river and behind Falmouth. The troops seemed to be in good spirits, and moved with a good degree of speed.

"In the afternoon I rode with Mr. William Swinton [the 'Times' correspondent with the army of the Potomac, and now Professor of History in the University of California] to General Sumner's head-quarters, which were at the Phillip's house, a large, fine, brick country mansion, about

midway between general head-quarters and the river, and a mile and a half from both. General Sumner received me with great cordiality. He was in fine spirits,—full of talk and of loyalty,—and impressed me as being one of the finest specimens of the old soldier to be found in any service. He gave us at dinner a bottle of champagne, but it did not make him in the least communicative as to approaching movements, though he went so far as to say that if we would stay with him three or four days he thought he could show us *work*. We rode back at 7, and intending to make an early start so as to be on the ground as soon as operations should commence, I went to my tent early. The General had put a very fine gray horse, with an orderly, at my disposal, and we were all to start at half-past five A. M.

"At about 8 P. M. it began to rain, at first slowly; soon the wind rose and the rain became a driving sleet, and through all the rest of the night the tempest fairly howled around and through the tent, and I spent nearly the whole night in thinking of the poor fellows who had left their camps, and would be compelled to bivouac for the night on the cold wet ground, without tents, and with the prospect of a bloody battle in the morning.

"In the morning, I got up at five, found that the General had not slept at all, and had received reports that the rain had arrested the movement of the pontoons and artillery, and that nothing could be done by the time designated. He did not come to breakfast, but had tea and toast sent to his sleeping tent. At seven, with four of his staff, he started up the river. It continued to rain hard, and as I knew this would render the time of commencing the movement wholly uncertain, I resolved to stay in my tent until the sound of artillery should announce the opening of the ball. The result was that I stayed in my tent all day. It rained and blew without ceasing. At five in the afternoon the General returned. He said the rain had made the ground so soft that it was impossible to move. Horses and wagons sank into the mud beyond hope of extrication. Twenty horses failed to start a single caisson. Men had been trying, 150 to each, to haul the pontoons, but without effect. The troops had not suffered much from their exposure, and were still in good spirits. But the horses and mules were worn out, and hundreds had died in the harness. The General ordered a regiment of cavalry to dismount and make pack horses of their animals, to carry forage and light commissary stores to the front, and directed Captain Myers, of the Quartermaster's Department, to bring up by extra train from Acquia Creek, a supply of whisky, so as to give each man a whisky ration in the morning.

"General Burnside said that Franklin, Hooker, and Woodbury continued to protest, verbally and in writing, against the movement, and that it seemed as if they had done everything in their power to retard and thwart it. General Wilcox soon came in bringing a letter from General Woodbury, in which he said that the bridges could not be put down, and that even if twenty bridges could be built the movement ought not to be made. Similar remarks were repeated from other officers. During dinner a telegram announced that the bridges over which Slocum's division must march to join the main body were down. The General was greatly perplexed by this untoward turn of events, but continued cheerful and hopeful nevertheless. He was sure it would all come out right at last.

"*Thursday, January 22nd.*—The night was drizzly and windy, but without heavy rain. Dr. Church

waked me at eight, and I went in to breakfast with General Burnside, General Parks, Chief-of-staff, and Dr. Church. The General said he had received fresh protests against the movement from the generals charged with its execution. General Hooker had sent down word that the chances were nineteen to one against its success. Franklin said success was *impossible*. Woodbury had repeated the opinion expressed in his letter of the day before. After breakfast, Mr. Swinton told me that General Hooker had talked very openly about the absurdity of the movement the day before,—that he had denounced the commanding general as incompetent, and the President and Government at Washington as imbecile and ‘played out.’ Nothing would go right, he said, until we had a dictator, and the sooner the better. This, Mr. Swinton said, was the general tenor of General Hooker’s conversation, which was perfectly free and unrestrained.

“General Burnside said that reports came in that the enemy had discovered the point at which a crossing was intended, and were evidently taking precautions against it. The mud continued to impede operations on our side; in this respect the rebels had somewhat the advantage of us, inasmuch as they had a plank road running up from Fredericksburgh along the river. General Burnside said he had decided to go to Washington and lay the whole matter before the President and General Halleck, leaving them to decide whether he should go forward with the movement or not. He disliked to go,—thought that perhaps he ought to take the whole responsibility himself. He knew that the whole country demanded a movement, and that the army and the cause *needed* a success. But he also knew how very difficult it would be to achieve a success while the sentiments of his general officers were so decidedly against the movement. I told him there could be no difficulty in making the public understand the absolute necessity of postponing the movement *after* the rain commenced; the real trouble would be to answer the question, why the movement had not taken place *sooner*, while the weather was good and the roads hard.

“He said he had attempted a movement *two* or three times. After the defeat at Fredericksburgh,—which was due, he said, to General Franklin’s disobedience of his orders,—he planned another advance for December 31st. The main attack was committed to General Sumner, while General Averill, with a picked force of cavalry and flying artillery (2,500 in all), was to make an extensive and startling raid upon the communications of the enemy to divert his attention. He had planned the whole movement with great care. Everything was ready, the orders were given, and the cavalry had proceeded nearly a day’s march on the way, when he received a telegram from President Lincoln, saying: ‘I have good reasons for saying you must make no movement without consulting me.’ General Burnside at once recalled the expedition and went to Washington. He called upon the President, and was told that certain of his subordinate officers had represented to him that the movement was very hazardous and almost certain to end disastrously. It was for this reason that he had sent him the despatch. General Burnside could not ascertain who these officers were (Mr. Swinton told me they were General Newton and General John Cochrane), nor could he receive any permission to go on with his movement. After a good deal of conversation, he told the President he was satisfied the country had lost confidence in the Secretary of War, General Halleck, and himself, and that in his judgment all three should resign.

“The next morning he wrote the President a letter stating the same thing, and giving a variety of reasons therefor, accompanying the letter with his own resignation. He then went to Stanton and *told him* what he had written. Stanton replied: ‘If you had as much confidence in yourself as others have in you, all would go well enough.’ The President complained that no one would shoulder a particle of responsibility which could be thrown off upon him. General Burnside’s resignation was refused, and he went back to his command. Thus ended *this* attempt at a forward movement. Then came the attempt which had just been thwarted by the rain, having first been delayed by the hostility of his generals and the condition of the pontoons.

“At ten General Burnside left by a special train for Washington. After he had gone, I had a good deal of conversation with General Parks, his chief-of-staff, who had been in former times a special favorite of Jefferson Davis. He said he was satisfied that the rebellion had been planned for a long time, and that Davis was very busy in arranging it while he was secretary of war under President Pierce. One trifling circumstance that satisfied him of this was, that he would never suffer any clerk to open the mails sent to the department. He always opened them himself, and after selecting such letters as he wished, he handed the others over to the proper clerks. When he was not at the department upon their arrival, he had them sent to his house; and if he happened to be out of town, they were always opened by his wife. General Parks said this showed clearly that he carried on, during all the time he was in the office, a correspondence designed to be secret, and he had now no doubt that it was on this very subject of secession.

“General Parks told me a good deal concerning the battle of Fredericksburg, in confirmation of what General Burnside had already told me. He said the General had ordered Franklin to push *at least one* division against the rebel right, and to support it strongly. Franklin sent Meade’s corps (the smallest of all) to the attack. Meade, however, *broke* the rebel lines, and actually got among their ammunition wagons and supply-train in the rear; and if he had been properly and promptly supported, he certainly would have turned them completely, and, as Burnside said, captured every gun. Franklin was very slow in sending support of any kind, and when he did so, they were too weak for the purpose. He afterward gave as a reason for this, that he was afraid the enemy would seize his bridges if he sent away too large a force. This was the reason why the battle was lost. The next day, General Burnside proposed to put himself at the head of his old Ninth Corps, 20,000 strong, and renew the attack upon the rebel right, so confident was he of his ability to break them. He (Burnside) afterward told me that if General Franklin had obeyed his orders, he would have captured every gun in the rebel army.

“At 12 o’clock, taking the General’s gray horse, I rode with Dr. Church to the advanced position of the army,—about eight miles. The road was muddy; but, having a hard bottom, was quite passable, even for cannon. It was only when they turned into the fields, or were obliged to take the country roads, that the mud became absolutely unconquerable. We found General Wadsworth in a small wood-house on a little farm, having just arrived and made it his headquarters. He said the men of his division had not suffered very seriously from the night march, and that they were rapidly making themselves comfortable in the woods. We told him we

had heard that the movement was to be abandoned. He said *he* would not abandon it if he had command. We suggested that cannon could not be moved at all. Then, he replied, he would make the attack with infantry, for the rebels couldn't move cannon any better than we could. He seemed in good spirits, and wished me, on my return to New York, to tell his wife that I left him heating water on the fire to shave himself.

"We returned to head-quarters at five, and found General Burnside there already. After we had joked him a little about the rapidity of his journey to Washington, he told us he had been only to Acquia Creek. Before leaving camp he had telegraphed to General Halleck as follows: 'I wish very much to see you for an hour. Will you come down to Acquia, or shall I go to Washington?' On reaching Acquia Creek he found a reply: 'Use your own judgment about coming up,' to which he answered at once: 'Yours received. I shall not come.' He seemed greatly annoyed and vexed at the apparent indifference of General Halleck to the movement of the army and to his wishes, and said he should not go to Washington to see him. While we were talking Lieutenant Bowen came down from General Hooker's head-quarters and said that Hooker was denouncing the attempted movement very freely and without the slightest restraint; even if the weather had been perfectly good, he said, the attempt to cross would have proved a failure. General Burnside said he should send to the President his *unconditional resignation* of his command—sending at the same time the removal of several of his field officers. I made no remark at the time, seeing that he was too much disturbed and excited to give the matter proper consideration.

"Friday, Jan. 23rd.—In the morning after breakfast General Burnside told me he had changed his mind about accompanying his letter of resignation with the removal of officers. He feared this would look too much like attempting to make *conditions* with the government, which he said he had no right to do. He had determined to resign and send his letter to Washington by special messenger. After Pope's repulse, when Washington was thought to be in great danger from the rebels, who were pushing into Maryland, General McClellan had refused to resume command of the Army of the Potomac unless Mr. Stanton or General Halleck should first be removed. He had not done this formally, but had told his friends that he should insist on these conditions. General Burnside said he talked with him until three o'clock in the morning to dissuade him from making any such conditions. He found him excessively stubborn about it, and finally told him that he had no right to take such a course, and that he could not possibly maintain his position before the country as a loyal man if, when the Capitol was in danger and the North invaded, he were to refuse the command except on such terms as he might prescribe. General McClellan finally yielded to these representations, resumed his command, and achieved by far the most considerable successes of his whole campaign. General Burnside said that half a dozen of the officers had also resolved to resign unless Pope was removed. He heard of it, got them together, remonstrated with them, and finally denounced them as disloyal for entertaining such a purpose, and in the end induced them to forego it. When they had come to their conclusion he told them General Pope *had been* removed.

"Soon afterward, being alone with the General, some question that he asked me gave me an oppor-

tunity of saying that I doubted the wisdom of his resigning. He asked me why. I said:

"You have planned a movement which, I take it for granted, will stand military criticism. You have been thwarted in its execution by the insubordination of your generals. Why should you relieve them from the responsibility of their conduct by assuming the blame of the failure yourself—for this is precisely what your resignation will imply.'

"What then,' said he, 'should I do?'

"Do you know,' I replied, 'what *ought* to be done?'

"Yes,' he said, 'these generals ought to be removed.'

"Very well,' I answered, 'then remove them. In that way you throw upon them what properly belongs to them, the responsibility of the *failure*, and take upon yourself what belongs to you as commander, the responsibility of the *remedy*.'

"But,' said he, 'the Government will not sustain me.'

"Then,' said I, 'you will have a good reason for resigning,—one on which you can go to the country with a certainty of being sustained. That is precisely such an issue as should be made. *Now*, so far as I can see, you have no reason whatever for resigning.'

"The General said this was a strong view of the case, and he would think of it. I apologized for the freedom with which I had spoken. He said he was greatly obliged to me for it. He asked my opinion and thanked me for having given it. He was having documents copied to be sent to Washington and would see me again.

"At half past eleven he called me into his office tent, and read the report he had written of his recent movement. It was brief and assigned the weather as the cause of his failure. He sent copies of all the orders he had issued, and referred to them for details."

The following extract from the report of the Congressional Investigating Committee may be found of interest in this connection:

"On the 26th of December an order was issued for the entire command to prepare three days' cooked rations, etc., etc., etc., * * * in fact, to be in a condition to move at twelve hours' notice. Shortly after that order was issued, General John Newton and General John Cochrane * * * came up to Washington on leave of absence. Previous to obtaining leave of absence from General Franklin, they informed him * * * they should take the opportunity to represent to some one in authority the dispirited condition of the army, and the danger there was of attempting any movement against the enemy at that time. When they reached Washington, General Cochrane * * * determined to seek an interview with the President for the purpose of making the communication directly to him. * * * That day the interview took place, and General Newton opened the subject to the President. * * * General Newton states that, while he firmly believed that the principal cause of the dispirited condition of the army was the want of confidence in the military capacity of General Burnside, he deemed it improper to say so to the President 'right square out,' and therefore endeavored to convey the same idea indirectly. * * * The day arranged [by General Burnside] to make the crossing [of the Rappahannock], he received from the President the following telegram:

‘I have good reason for saying that you must not make a general movement without letting me know of it.’ General Burnside stated that he could not imagine at the time what reason the President could have for sending him such a telegram. None of the officers of his command, except one or two of his staff who had remained in camp, had been told anything of his plan beyond the simple fact that a movement was to be made. * * * General Burnside came to Washington to ascertain from the President the true state of the case. He was informed by the President that some general officers from the Army of the Potomac, whose names he declined to give, had called upon him and represented that General Burnside contemplated soon making a movement, and that the army was so dispirited and demoralized that any attempt to make a movement at that time must result in disaster.

“General Burnside informed the President that none of his officers had been informed what his plan was. * * * He urged upon the President to grant him permission to carry it out, but the President declined to do so at that time. General Halleck and Secretary Stanton were sent for, and then learned, for the first time, of the President’s action in stopping the movement. * * * General Halleck, with General Burnside, held that the officers who had made those representations to the President should be at once dismissed the service.”

I find in another part of the memoranda an interesting account of the circumstances under which General Burnside assumed the responsibility for the battle of Fredericksburg,—or rather for its loss,—and his interview with the President and Secretary Stanton. I insert it here, although in point of time it should *precede* the entire article.

“In the evening (January 22nd, 1863) I dined with Lieutenant Goddard and three other young aids of the General. * * * After dinner General Burnside sent for me. I found him with Swinton (our correspondent), in a towering passion about a paragraph in one of his letters stating that General Burnside had written his letter assuming the whole responsibility of the battle of Fredericksburg at the dictation of, or in connivance with, the government. * * * After I came in we had a free conversation on the subject. The General was very indignant that he should be thought capable of stating what was not true at the bidding of the government, or to screen them or anybody else from any responsibility that belonged to them. He gave in detail the history of the letter. He said that on the 20th of Decem-

ber, 1862 [the battle of Fredericksburg occurred December 13th, 1862], Dr. Church returned from Washington, bringing newspapers containing violent attacks on the President, Secretary of War, and General Halleck for having forced him to fight against his judgment. Dr. Church told him that this was the general tone of conversation at Washington. The General at once said: ‘I’ll put a stop to that,’—and wrote a note avowing that he and he alone was responsible for the battle, and saying that he would send it to the Associated Press for publication. Several officers of his staff remonstrated warmly against his making any such publication, telling him he was not called on to interpose in defense of the government, and especially that he ought not to enter upon any newspaper publications. To the former he replied that he would never permit any one to suffer for acts of which the entire responsibility belonged to him. To the latter he yielded so far as to consent to take the letter with him to Washington, and to give it in the form of an official letter addressed to General Halleck.

“The next day he went to Washington and called upon the President. He found him greatly depressed by the attacks made upon him for the Fredericksburg affairs, and at once told him he would relieve him from all uneasiness on that score by publishing a letter, taking the whole responsibility upon his own shoulders. The President seemed greatly relieved, and told him he was the first man he had found who was willing to relieve him of a particle of responsibility.

“The General returned to the hotel and wrote the letter. Soon after (next morning) he called on the President, who told him the Secretary of War wished to see him, and that he would go with him. Both went out. Mr. Stanton received him coldly, and finally said to him: ‘You have not published the letter which you promised the President you would publish.’ General Burnside said that the rebuke made him angry. He told the Secretary this was wholly a private matter between him and the President,—that he should do as he pleased about it, and that he should not submit to any official rebuke or interference in regard to it. He then left the room. But soon after the President sent for him, and told him the Secretary wished to see him. He returned, and Mr. Stanton very handsomely apologized for the heat he had shown, and disclaimed any wish to dictate to him on the subject. General Burnside accepted his explanation, and then told him, in order that he might see how much he had wronged him, that at the very time of the former conversation, the letter was on its way to New York. This, he said, was the history of the letter. It was certainly very creditable to him in every way.”

COR CORDIUM.

P. B. S.

THROBBING and strong and warm,
 Within his earthly form
 The heart took up its dwelling,
 Ere yet life’s dawn was bright.
 Through sunny days and dark
 Burned the small vital spark,
 Now crushed with pain, now swelling
 With delight.

Strong with the strength of love,
 Yet gentle as a dove,
 It touched the hearts around it,
 Saddened, or cold, or dull;
 And through the shadowy years,
 The questionings, the fears,
 It made life, as it found it,—
 Beautiful.

How brief is mortal breath!
 How dear the good to Death!
 Yet west winds whispered warning,
 The sensitive-plant's heart bled,
 Ere shoreward borne was he
 On the Italian sea,
 One limpid summer morning,—
 Cold and dead.

They reared a funeral pyre;
 And, wrapped in crimson fire,
 With wine and incense mingled,
 The body rose in air.
 Changed was each earthly part
 To ashes, save the heart,
 Which, from the dust out-singled,
 Rested there!

Beneath a ruin's shade
 That heart is lowly laid;
 And from the sward above it
 The dark-leaved ivy starts.
 You'd ne'er have credited
 (It seems so still and dead)
 How many loved, *and love*, it,—
 Heart of hearts!

 THIRZA.

SHE stood by the window, looking out over the dreary landscape, a woman of some twenty-five years, with an earnest, even melancholy face, in which the wistful brown eyes were undoubtedly the redeeming feature. Jones' Hill, taken at its best, in full parade uniform of summer green, was not renowned for beauty or picturesqueness, and now, in fatigue dress of sodden brown stubble, with occasional patches of dingy white in ditches and hollows and along the edges of the dark pine woods, was even less calculated to inspire the beholder with enthusiasm. Still, that would hardly account for the shadow which rested upon Thirza Bradford's face. She ought, in fact, to have worn a cheerful countenance. One week before she had been a poor girl, dependent upon the labor of her hand for her daily bread; to-day she was sole possessor of a farm of considerable extent, the comfortable old house at one of whose windows she was now standing, and all that house's contents.

One week before she had been called to the bedside of her aunt, Abigail Leavitt. She had arrived none too soon, for the stern, sad old woman had received her summons, and before another morning dawned had passed away.

To her great surprise, Thirza found that her aunt had left her sole heiress of all she had possessed. Why she should have been surprised would be difficult to explain. Aunt Abigail's two boys had gone to the

war and never returned, her husband had been dead for many years, and Thirza was her only sister's only child, and sole surviving relative. Nothing, therefore, was more natural than this event, but Thirza had simply never thought of it. She had listened, half in wonder, half in indifference, to the reading of the will, and had accepted mechanically the grudgingly tendered congratulations of the assembled farmers and their wives.

She had been supported in arranging and carrying out the gloomy details of the funeral by Jane Withers, a spinster of a type peculiar to New England; one of those persons who, scorning to demean themselves by "hiring out," go about, nevertheless, from family to family, rendering reluctant service "just to accommodate" (accepting a weekly stipend in the same spirit of accommodation, it is to be supposed). With this person's assistance, Thirza had prepared the repast to which, according to custom, the mourners from a distance were invited on their return from the burying-ground. Aunt Abigail had been stricken down at the close of a Saturday's baking, leaving a goodly array upon the pantry shelves, a fact upon which Jane congratulated herself without any attempt at concealment, observing, in fact, that the melancholy event "couldn't have happened handier." In vain had Thirza protested—Jane was inflexible, and she had looked on with silent horror, while the funeral guests calmly

devoured the pies and ginger-bread which the dead woman's hands had prepared.

"Mis' Leavitt were a master hand at pie-crust," remarked one toothless dame, mumbling at the flaky paste, "a *master* hand at pie-crust, but she never were much at bread!" whereupon the whole feminine conclave launched out into a prolonged and noisy discussion of the relative merits of salt-risin's, milk-emptin's, and potato yeast.

That was three or four days ago, and Thirza had remained in the old house with Jane, who had kindly proffered her services and the solace of her companionship. There had been little to do in the house, and that little was soon done, and now the question of what she was to do with her new acquisition was looming up before her, and assuming truly colossal proportions. She was thinking of it now as she stood there with the wistful look upon her face, almost wishing that Aunt Abigail had left the farm to old Jabez Higgins, a fourth or fifth cousin by marriage, who had dutifully appeared at the funeral, with a look as if he had that within which passed showing, and doubtless he had, for he turned green and blue when the will was read, and drove off soon after at a tearing pace.

Jane, having condescended to perform the operation of washing up the two plates, cups, etc., which their evening meal had brought into requisition, entered presently, knitting in hand, and seated herself with much emphasis in a low wooden chair near the window. She was an erect and angular person, with an aggressive air of independence about her, a kind of "just-as-good-as-you-are" expression, which seemed to challenge the observer to dispute it at his peril. She took up the first stitch on her needle, fixed her sharp eyes upon Thirza, and, as if in answer to her thoughts, opened on her as follows:

"Ye haint made up yer mind what ye're a-goin' ter dew, hev ye?"

Thirza slowly shook her head, without looking around.

"It's kind o' queer now how things does work a-round. There you was a-workin' an' a-slavin' in that old mill, day in an' day out, only a week ago, an' now you can jest settle right down on yer own place an' take things easy."

Thirza vaguely wondered why Aunt Abigail had never "taken things easy."

"I shouldn't wonder a mite," went on Jane, with increasing animation, "I shouldn't

wonder a single mite if you should git a husband, after all!"

Thirza's pale face flushed, and she made an involuntary gesture of impatience with one shoulder.

"Oh, ye needn't twist around so," said the undaunted spinster, dryly. "Ye aint no chicken, laws knows, but ye need n't give up all hopes. Ye're twenty-five if ye're a day, but that aint nothin' when a woman's got a farm worth three thousand dollars."

Three thousand dollars! For the first time her inheritance assumed its monetary value before Thirza's eyes. Hitherto she had regarded it merely as an indefinite extent of pastures, woods, and swamps—but three thousand dollars! It sounded like a deal of money to her, who had never owned a hundred dollars at one time in her life, and her imagination immediately wandered off into fascinating vistas, which Jane's prosaic words had thrown open before her. She heard, as in a dream, the nasal, incisive voice as it went on with the catalogue of her possessions.

"Yes, it's worth three thousand dollars, if it's worth a cent! I heerd Squire Brooks a-tellin' Orthaniel Stebbins so at the funeral. An' then, here's the house. There aint no comfortabler one on Joneses' Hill, nor one that has more good furnitour an' fixin's in it. Then there's Aunt Abigail's clo'es an' things. Why, ter my *sartain* knowledge there's no less'n five real good dresses a-hangin' in the fore-chamber closet, ter say nothin' of the bureau full of under-clo'es an' beddin'." Jane did not think it necessary to explain by what means this "sartain knowledge" had been achieved, but continued: "There's a silk warp alpacky now, a-hangin' up there, why—it's e'en-a-most as good as new! The creases aint out on't." (Unsophisticated Jane! not to know that the creases never *do* go out of alpaca.) "I don't see what in the name o' sense ye're a-goin' ter dew with all them dresses. It'll take ye a life-time ter wear 'em out. If I hed that silk warp alpacky now,"—she continued, musingly, yet raising her voice so suddenly that Thirza started; "if I hed that are dress, I should take out two of the back breadths for an over-skirt—yes—an' *gore* the others!" This climax was delivered in triumphant tone. Then lowering her voice she continued, reflectively: "Aunt Abigail was jest about my build."

Thirza caught the import of the last words.

"Jane," said she, languidly, with an undertone of impatience in her voice (it was hard to be recalled from her pleasant wanderings by a silk warp alpaca!), "Jane, you can have it."

"Wh-what d'ye say?" inquired Jane, incredulously.

"I said you could have that dress; I don't want it," repeated Thirza.

Jane sat a moment in silence before she trusted herself to speak. Her heart was beating rapidly, but she did not allow the smallest evidence of joy or gratitude to escape in word or look.

"Wall," she remarked, coolly, after a fitting pause, "ef you haint got no use for it, I might take it, I s'pose. Not that I'm put tew it for clo'es, but I allers did think a sight of Aunt Abigail——"

Her remarks were interrupted by an exclamation from Thirza. The front gate opened with a squeak and closed with a rattle and bang, and the tall form of Orthaniel Stebbins was seen coming up the path. Orthaniel was a mature youth of thirty. For length and leanness of body, prominence of elbow and knee joints, size and knobiness of extremities, and vacuity of expression, Orthaniel would have been hard to match. He was attired in a well-preserved black cloth suit, with all the usual accessories of a rustic toilet. His garments seemed to have been designed by his tailor for the utmost possible display of the joints above mentioned, and would have suggested the human form with equal clearness, if buttoned around one of the sprawling stumps which were so prominent a feature in the surrounding landscape. On this particular occasion there was an air of importance, almost of solemnity, about his person, which, added to a complacent simper, born of a sense of the delicate nature of his present errand, produced in his usually blank countenance something almost amounting to expression.

At first sight of this not unfamiliar apparition, Thirza had incontinently fled, but Jane received the visitor with becoming impressiveness.

"Good-evenin', Mr. Stebbins. Walk right into the fore-room," she remarked, throwing open the door of that apartment of state.

"No need o' puttin' yourself out, marm; the settin'-room's good enough for me," graciously responded the gentleman.

"Walk right in," repeated Jane, throwing open one shutter, and letting in a dim light upon the scene—a veritable chamber

of horrors, with its hideous carpet, hair-cloth chairs and sofa, the nameless abominations on its walls, and its general air of protest against the spirit of beauty and all that goes to make up human comfort.

Mr. Stebbins paused on the threshold. There was something unusually repellent about the room, a lingering funereal atmosphere, which reached even his dull senses. He would have infinitely preferred the sitting-room; but a latent sense of something in his errand which required the utmost dignity in his surroundings prevailed, and he therefore entered and seated himself on one of the prickly chairs, which creaked expostulatively beneath him.

"I—ahem! Is Miss Bradford in?"

This question was, of course, a mere form,—a *ruse de guerre*, as it were,—and Mr. Stebbins chuckled inwardly over his remarkable diplomacy. He had seen Thirza at the window, and witnessed her sudden flight; but, so far from feeling affronted by the act, it had rather pleased him. It indicated maiden shyness, and he accepted it as a flattering tribute to his powers of fascination. "She's gone to fix up her hair, or somethin'," he reflected.

When Jane came to summon her, she found Thirza sitting by the window of the fore-chamber, gazing thoughtfully out into the twilight again.

"Thirzy!" whispered the spinster, as mysteriously as if Mr. Stebbins was within possible ear-shot, "Orthaniel Stebbins wants ter see ye. Go right down!"

"Jane, I—sha'n't!" answered Thirza, shortly.

Jane started, and opened her small gray eyes their very widest.

"Wh—at?" she stammered.

"I mean I don't want to go down," said Thirza, more politely. "I don't wish to see him."

"Wall, if that don't beat the master!" exclaimed Jane, coming nearer. "Why, he's got on his Sunday clo'es! 'S likely 's not he's a-goin' ter propose ter ye!"

"You had better send him away, then," said Thirza.

"Ye don't mean to say ye wouldn't hev him!" gasped Jane, with a look of incredulous amazement which, catching Thirza's eye, caused her to burst into a laugh.

"I suppose I must go down," she said at last, rising. "If I don't, I shall have all Jones' Hill down upon me. Oh dear!"

Mr. Stebbins would have been surprised

to see that she passed the mirror without even one glance.

"Hadn't ye better take off yer apron, an' put on a pink bow, or somethin'?" suggested Jane; "ye look real plain."

Thirza did not deign to reply, but walked indifferently away.

"Wall!" ejaculated the bewildered spinner, "I hope I may never!" And then, being a person who believed in improving one's opportunities, she proceeded at once to a careful re-examination of the "silk-warp alpacky," which hung in straight, solemn folds from a nail in the closet; it had hung precisely the same upon Aunt Abigail's lathy form.

Thirza went into the gloomy fore-room. It struck a chill to her heart, and she went straight past Mr. Stebbins, with merely a nod and a "good-evening," and threw open another shutter, before seating herself so far from him, and in such a position, that he could only see her face by an extraordinary muscular feat. Mr. Stebbins felt that his reception was not an encouraging one. He hemmed and hawed, and at last managed to utter:

"Pleasant evenin', Miss Bradford."

"Very," responded Thirza. It was particularly cold and disagreeable outside, even for a New England April.

"I guess we kin begin plantin' by next week," continued the gentleman.

"Do you really think 'so?" responded Thirza, in an absent sort of way.

It was not much; but it was a question, and in so far helped on the conversation. Mr. Stebbins was re-assured.

"Yes," he resumed, in an animated manner, "I actooally dew! Ye see, Miss Bradford, ye haint said nothin' tew me about the farm, so I thought I'd come 'roun' an' find out what yer plans is."

"I haven't made any," said Thirza, as he paused.

"Oh—ye haint? Well, ye know I've been a-workin' on't on shares fur yer aunt Abigail, goin' on five year, an' I'm ready ter dew the same fur *you*, that is——" and here Mr. Stebbins hitched a little nearer, while a smile, which displayed not only all his teeth, but no little gum as well, spread itself over his bucolic features, "that is, if we can't make no other arrangements more pleasin'."

There was no mistaking his intentions now; they spoke from every feature of his shrewdly smiling countenance, from his agitated knees and elbows, and from the

uneasy hands and feet which seemed struggling to detach themselves from their lank continuations and abscond then and there.

Thirza looked her wooer calmly in the face. Her imperturbability embarrassed but did not dishearten him.

"Thar aint no use in foolin' round the stump!" he continued. "I might jest as well come out with it, plain an' squar! I'm ready an' willin' to take the *hull* farm off yer hands if you're agreeable. You jest marry me, Thirzy, an' that settles the hull question slick as a whistle!" and Mr. Stebbins settled back in his chair with a look as if he had just elucidated a long-mooted problem in social science.

Thirza rose: there was a little red spot on each cheek, and an unwonted sparkle in her soft eyes; but her manner was otherwise unruined as she answered:

"You are really very kind, Mr. Stebbins, but I think I shall find some other way out of the dilemma. I couldn't think of troubling *you*."

"Oh——" he stammered, "taint—no trouble—at all!"

But Thirza was gone.

For a moment the Adonis of Jones' Hill doubted his identity. He stared blankly at the open door awhile, and then his eyes wandered vacantly over the carpet and wall, finally coming to rest upon the toes of his substantial boots. He sat for some time thus, repeating Thirza's words as nearly as he could recall them, endeavoring to extract the pith of meaning from the surrounding fibers of polite language. Had she actually refused him? Mr. Stebbins, by a long and circuitous mental process, arrived at length at the conclusion that she had, and accordingly rose, walked out of the front door and down the narrow path, in a state of mind best known to rejected suitors. As he closed the gate he cast one sheepish look toward the house.

"I'll be darned!" he muttered, "I'll be darned if I haint got the mitten!" and, discomfited and sore, he disappeared in the evening shadows.

Jane was watching his departure from behind the curtain of the sitting-room window. In all probability her gentle bosom had never been the scene of such a struggle as was now going on beneath the chaste folds of her striped calico gown. She could not doubt the object of Mr. Stebbins's visit, nor its obvious result. Astonishment, incredulity, curiosity, in turn possessed her.

"Wall!" she soliloquized, as the curtain

fell from her trembling fingers, "the way some folks fly in the face of Providence do beat the master!"

Thirza, too, had observed her suitor as he strode away, with an expression of scorn upon her face which finally gave way to one of amusement, ending in a laugh—a curious hysterical laugh. A moment later she had thrown herself upon the bed, and Jane, who in a state of curiosity bordering on asphyxia, came up to the door soon after, heard a sound of sobbing, and considerably went away.

Thirza had her cry out; every woman knows what that means, and knows, too, the mingled sense of relief and exhaustion which follows. It was fully an hour later when she arose and groped her way down into the sitting-room where Jane sat knitting zealously by the light of a small lamp. That person's internal struggles commenced afresh, and a feeling of indignation quite comprehensible burnt in her much-vexed bosom as Thirza, after lighting another lamp, bade her "good-night," and went out of the room, leaving her cravings for fuller information unassuaged.

Once more in her room, Thirza seated herself before the glass and began to loosen the heavy dark braids of her hair. Upon the bureau lay an open letter, and leaving the soft tresses half undone, she took it up and re-read it. When she had finished she let it fall upon her lap and fell to thinking. The letter was from her cousin Sue, and bore a foreign post-mark, and from thinking over its contents Thirza fell into reflections upon the diversity of human fate, particularly her own and Sue's. They had commenced life under very similar circumstances. Both had been born about the same time, and in the town of Millburn. Both were "only" children, the fathers of both were mechanics of the better class, and the girls were closely associated up to their fourteenth year, as play-fellows and school-mates. Sue was an ordinary sort of a girl, with a rather pretty blonde face; Thirza, a bright, original creature, with a mobile, dark face, which almost every one turned to take a second look at; a girl who, with a book, almost any book, became oblivious of all else. Her father was a man of more than ordinary intelligence, of a dreamy, speculative turn of mind, and subject to periods of intense depression. When she was about fourteen years old, Thirza went one evening to the barn to call her father to supper. Receiving no answer to her

call, she entered, and there, in a dim corner, she saw *something* suspended from a beam,—something she could never efface from her memory. A shaft of sunlight full of dancing motes fell athwart the distorted face, whose smile she must now forever miss, and across the rigid hands which would never again stroke her hair in the old fond, proud way. In that moment the child became a woman. She went to the nearest neighbor, and without scream or sob told what she had seen—then she went to her mother. Soon after, the young girl whose school-life was thus early ended took her place at a loom in one of the great cotton-mills, and there she remained for more than ten years, the sole support and comfort of her weak, complaining mother, who from the dreadful day that made her a widow, sank into hopeless invalidism. One year previously to the commencement of this story she had been laid to rest. In the meantime Sue had grown up, and married a "smart fellow," who after a few years of successful business life in New York, had been sent by some great firm to take charge of a branch establishment in Paris.

Thirza was thinking of these things now, as she sat with Sue's gossipy letter on her lap—thinking of them wearily, and even with some bitterness. It seemed to her hard and strange that Sue should have everything, and she only her lonely, toilsome life, and her dreams. These indeed remained; no one could forbid them to her—no amount of toil and constant contact with sordid natures could despoil her of her one priceless treasure, the power to live, in imagination, brief but exquisite phases of existence which no one around her ever suspected. Ah, books! They furnished an innocent hasheesh, which transported her out of the stale atmosphere of her boarding-house into realms of ever new delight.

But to-night she could not dream. The interview with Mr. Stebbins had been a rude shock, a bitter humiliation to her. She had held herself so proudly aloof from the men of her acquaintance that none had ever before ventured to cross the fine line of reserve she had drawn about her; and now, this uncouth, mercenary clown had dared pull down the barrier, and trample under foot the delicate flowers of sentiment she had cherished with such secrecy and care. Her first wooer! Not thus, in the idle dreams which come to every maiden's heart, had Thirza pictured him. That other rose

before her now, and strangely enough, it took on the semblance, as it often had of late, of one she had almost daily seen—a handsome face, a true and good one, too; and yet the hot blood surged into her cheeks, and she tried to banish the image from her mind. It would not go at her bidding, however, and, as if to hide from her own eyes in the darkness, Thirza arose and put out the light.

There was no time for dreaming after this, for the question of her inheritance must be settled. So, after a day or two of reflection, Thirza drove into town and held a long consultation with Squire Brooks, the result of which was that the farm was announced for sale. It was not long before a purchaser appeared, and in due course of time Thirza found herself, for the first time in her life, in possession of a bank-book!

She returned to her place in the mill, notwithstanding, and was secretly edified in observing the effect which her re-appearance produced upon the operatives. The women watched her askance, curiously and enviously, indulging in furtive remarks upon her unchanged appearance. As an heiress something had evidently been expected of her in the way of increased elegance in dress, and its non-appearance excited comment. On the part of the men there was a slight increase of respect in their mode of salutation, and in one or two instances, an endeavor to cultivate a nearer acquaintance, an endeavor, it is needless to say, without success.

But if there was no outer change in Thirza, there was an inner change going on, which became at length a feverish restlessness, which disturbed her night and day. She found herself continually taking down from her shelves certain fascinating books, treating of foreign scenes and people; reading and re-reading them, and laying them aside with strange reluctance. Then she fell into a habit of taking her little bank-book, and figuring assiduously upon the covers. Three thousand dollars! Enough, she bitterly reflected, to keep her from the almshouse when her hands became too feeble to tend the loom, but a paltry sum, after all! Many persons, even in Millburn, spent far more than that yearly.

All at once a thought flashed upon her, a thought which took away her breath and set her brain to whirling. And yet it was not an absolutely new thought. It had haunted her under various disguises from the moment when Jane Withers, by a few

words, had transmuted the barren pastures and piney woods of her farm into actual dollars; and now, after hovering about all this time, it had found a moment,—when some fascinating book had thrown her off her guard,—to spring upon and overpower her. For a moment she was stunned and overwhelmed—then she calmly closed the little bank-book, and said: “I will do it!”

In one week the whole town knew that Thirza Bradford was going to travel, and all former discussions of her affairs sank into nothing in comparison with the importance they now assumed. Among her immediate acquaintances there was considerable excitement, and their opinions were freely, if not elegantly, expressed. The men, almost without exception, pronounced her “a fool,” as did the elder women, whose illusions, if they had ever entertained any, had long since been dispelled. But among the younger women there was a more or less repressed feeling of sympathy, amounting to envy. Poor girls! they, too, no doubt, indulged in secret longings which their prosaic work-a-day world failed to satisfy; and doubtless those who had themselves “aunt Abigail,” or any other “expectations” of a like nature, were led into wild and wicked speculations upon the tenure of human life, for which, it is to be hoped, Thirza will not be held accountable.

It is the fashion of the day to ascribe our more objectionable peculiarities and predilections to “hereditary taint,” and there is something so comforting and satisfactory in this theory, that it has attracted many adherents not otherwise of a scientific turn of mind. Millburn was not scientific; but even Millburn fell into the same way of theorizing.

“Bill Bradford,” said public opinion, “was an oneasy sort of a chap,—a half crazy, extravagant critter,—and Thirzy is a chip o’ the old block.”

When the news reached Jones’ Hill,—which it shortly did by the never-failing means of Jane Withers, who was accommodatingly helping Orthaniel’s mother through a course of “soap-bilin’”—the comments were severe. Orthaniel received the tidings as he was about starting for the cow-yard, with a milk-pail in each hand. He listened, with fallen jaw, unto the bitter end. Then, giving his blue overalls an expressive hitch, he remarked ungraciously:

“That gal haint got no more sense ’n a yaller dog!”—and he, at least, may be pardoned for so thinking.

As for Thirza, her decision once made, she troubled herself little about the "speech of people." From the moment when she had closed her little bank-book with the words "I will do it," she became, not another woman, but her real self. She went serenely about her simple preparations for her departure in a state of quiet exultation which lent a new charm to her dark face and a new grace to her step.

Squire Brooks arranged her money affairs for her,—not without remonstrance, however. It seemed to the close-fisted, elderly man a wild and wanton thing to do; but there was something in the half-repressed enthusiasm of the girl which caused the wise, prudential words to die upon his lips. When she left his office, on the evening before her departure, he watched the light-stepping figure out of sight, and then walked up to the dingy office mirror and surveyed his wrinkled visage on all sides. Carefully brushing up the sparse gray locks which had been ordered to the front, as it were, to fill the gaps created by Time's onslaughts, he shook his head deprecatingly, and with a sigh walked away from the glass, humming softly "Mary of Argyle."

As Thirza, absorbed in thought, turned into the long, shaded street which led down to her boarding-house, she was startled out of her reverie by the sound of her own name, pronounced in a friendly tone. Looking up, she saw a gentleman approaching. Her heart gave a quick leap as she recognized Warren Madison, son of the richest manufacturer of Millburn. He was no recent acquaintance. In their school days, when social distinctions weighed but little, there had been a childish intimacy and fondness between them. Time and separation, and the wide difference in their position,—which she, at least, felt most keenly,—had estranged them. Since the young man's return, after years of study and travel, to become his father's partner, she had met him very often, both in the mill and outside of it, and he had constantly shown a disposition to renew their former friendship. But poor, proud Thirza had rejected all his advances. Even now, although her cheeks tingled and her hands trembled nervously, she would have passed him with a simple nod; but somehow, before she realized it, young Madison had secured her hand and a smile, too; and, to her surprise, she found herself walking by his side, talking with something of the familiarity of the old school days.

"I have been absent for some time, and only heard to-day that you are going away," he said.

"Yes," responded Thirza. "I am going away—to Europe."

"To seek your fortune?" said he, with a smile.

"No—to spend it," said Thirza, in the same manner. "I suppose that you, like Parson Smythers and the rest of Millburn, consider it an 'extray-ordinary proceeding,'"—this with a fair imitation of the reverend gentleman's peculiar drawl.

Madison smiled.

"Don't count me among your judges, I beg of you, Thirza," he responded, more gravely. "Perhaps I understand you better than you think."

She glanced quickly up into his face,—a handsome face, frank and noble in its expression.

"Understand me?" she repeated; "I don't think any one understands me. Not that they are to blame—I am hardly worth the trouble, I suppose. I know," she continued, moved by an impulse to unburden her heart to some one, "I know that people are discussing and condemning me, and it does not trouble me at all to know it; but I don't mind saying this much to you." She caught the last two words back between her lips, but not before they had reached the young man's ears. He glanced quickly into her downcast face, with a look full of eager questioning; but this Thirza did not see, for she had turned her eyes away in confusion. "You know what my life has been," she went on impetuously. "I have never had any youth. Ever since I was a child, I have toiled to keep body and soul together. I have succeeded in feeding the one; but the other has starved. I have weighed everything in the balance. I am all alone in the world—all I had to live for is—up there." She pointed over her shoulder toward the old burying-ground. "I may be foolish,—even selfish and wicked,—but I can't help it! I am going to leave everything behind me, all the work and all the worry, and give myself a holiday. For one whole year I am going to *live*—really *live*! After that, I can bear the old life better—perhaps!"

The girl was almost beautiful as she spoke, with the soft fire in her eyes and her cheeks aglow. Her voice was sweet and full, and vibrated like a harp-string. The young man beside her did not look at her. He walked steadily forward, gazing straight

down into the dusty road, and striking out almost savagely with his cane at the innocent heads of the white clover which crowded up to the road-side.

"I think I know how you feel," he said, after a while. "Why, do you know, I have often had such thoughts myself. Better one year of real life, as you say, than a century of routine, such as mine is now!"

By this time they had reached the door of Thirza's boarding-house. There were faces at almost every window of the much-windowed establishment, to say nothing of those of the neighboring houses; but neither Thirza nor her companion was aware of this.

They stood on the steps a moment in silence; then he held out his hand. As she placed her own within it, she felt it tremble. Their eyes met, too, with a swift recognition, and a sharp, sweet pain went through her heart. She forced herself to turn her eyes away, and to say quietly:

"Good-evening and good-bye, Mr. Madison."

The young man dropped her hand and drew a quick breath.

"Good-bye, Thirza," he said; "may you find it all that you anticipate. Good-bye."

And the score or more pairs of inquisitive eyes at the surrounding windows saw young Mr. Madison walk calmly away, and Miss Bradford, with equal calmness, enter her boarding-house.

The next morning Thirza went away, and, the nine days' wonder being over, she was dropped almost as completely out of the thoughts and conversation of the people of Millburn as if she had never existed.

We will not accompany her on her travels. There was a time when we might have done so; but alas, for the story-writer of to-day! Picture-galleries, palaces, and châteaux, noble, peasant, and brigand, gondolas, volcanoes, and glaciers,—all are as common and familiar to the reader of the period as bonbons. It is enough to say that Thirza wandered now in reality, as she had so often in fancy, through the storied scenes which had so charmed her imagination; often doubting if it were indeed herself, or if what she saw were not the baseless fabric of a vision, which the clanging of the factory bell might demolish at any moment.

Sue's astonishment when Thirza, after two months in England and Scotland, walked one day into her apartment in Paris, quite unannounced, can be imagined. She wondered and conjectured, but, as her unex-

pected guest was neither awkward nor badly dressed, accepted the situation gracefully, and ended by really enjoying it. After delightful Paris days, came Italy, Germany and Switzerland, and then more of Paris, and at last came a time when inexorable figures showed Thirza plainly that she must think of returning to America.

"Thirza," protested Sue, "you really *mustn't* go."

For answer Thirza held up to view a travel-stained porte-monnaie.

"Perhaps we can arrange it somehow," persisted her cousin, vaguely. "You might take a situation as governess, you know;" these words were uttered doubtfully, and with a deprecating glance at the face opposite.

"Thank you!" responded Thirza. "I don't feel a call in that direction. I think, on the whole, I'd prefer weaving cotton."

"You'll find it unendurable!" groaned Sue.

"Well, *que voulez vous?*" responded her cousin, lightly; a quick ear would have noted the slight tremor in her voice. "I have had a glorious holiday."

"But the going back will be simply dreadful," persisted Sue. "I wish I were rich—then you shouldn't go!"

"I hardly think that would make any difference, my dear cousin. I don't think I am eminently fitted to become a parasite," laughed Thirza.

"Do you know what you *are* eminently fitted for?" cried Sue, energetically.

"Sue!" cried Thirza, warningly.

"I don't care," Sue continued daringly; "you are so set on going back to America that I half suspect——"

"Don't, Sue, please!" interrupted Thirza, with such evident signs of genuine displeasure, that Sue, who stood somewhat in awe of her cousin, ceased to banter, mentally vowing that she was "the queerest girl she had ever met with."

Thirza arose and went out into the flower-adorned balcony. She sought distraction, but somehow the surging, chattering crowd in the street below, the brilliant illumination, the far-off strains of music, did not bring her what she sought.

"If only Sue wouldn't!" she reflected, and then, between her and the sea of heads, and the lights and the flowers rose a face—the face that had troubled her meditations on Jones' Hill, that had followed her in all her wanderings, the noble face, with its blue eyes bent upon her so earnestly, so eloquently. Had she read

aright, even if too late, the meaning of those eyes as they met hers at parting? The same sweet, sharp pain that was not all pain, shot through her heart, and a consciousness of something blindly missed, something perversely thrown away, came over her. Sighing, she arose, and in response to Sue's call, went in and dressed for a gay party, in which, in her present mood, she felt neither pleasure nor interest. "If people here knew what a pitiful fraud I am—what a despicable part I am acting!" she said to herself, as, well-dressed and handsome, she entered the brilliant *salon*.

It was all over in a few days, and Thirza was sailing homeward as fast as wind and wave and steam could carry her. The year that had passed had brought little outward change in the girl. She looked fairer and fresher, perhaps, and certain little rusticities of dress and speech and manner had disappeared—worn off, as had the marks of toil from the palms of her slender hands. But to all intents and purposes, the tall figure in its close-fitting brown suit, which during the homeward voyage sat for the most part in the vessel's stern, gazing back over the foaming path, was the same which had watched a year before with equal steadiness from the steamer's bow. The very same, and yet—the girl often wondered if she were indeed the same, and lost herself in speculations as to how the old life in Millburn would seem to her now. She recalled with inflexible accuracy the details of her existence there, and tried to look her future undauntedly in the face. But all her philosophy failed her when in imagination she found herself upon the threshold of the old mill. There, indeed, she faltered weakly, and turned back.

When at last, one evening in June, she stepped out of the train at the little station of Millburn, a crowd of bitter thoughts came rushing upon her, as if they had been lying in wait there to welcome her. She had informed no one of her coming, and it was not strange that no friendly face greeted her, and yet, as she pursued her way alone through the silent, unlighted streets, her heart grew faint within her. How poor and meager everything seemed! The unpaved streets, the plank sidewalks, the wooden houses, and yonder, across the river, the great mills, looming grim and shapeless through the dusk! The long, glorious holiday was over—there lay her future.

Weary and sick at heart she entered her

boarding-house. The old familiar aroma saluted her, the hard-featured landlady welcomed her with a feeble smile, the unwashed children with noisy demonstrations.

Her room was at her disposal, and under the plea of fatigue she kept out of sight the whole of the succeeding day, which happened to be Sunday. She lay the greater part of the day upon the old lounge, looking round upon the well-known furnishings with a weary gaze. How small and shabby the room, how hideous the wall paper, how mean and prosaic everything, and the very canaries in their cage had forgotten her, and screamed shrilly at her approach!

That was a long day—the longest of her life, she thought. But the girl was made of good stuff; she made a brave fight, and this time came off conqueror. When Monday morning came, she arose and dressed herself in the old gray working suit, smiling back encouragement to her reflection in the glass as if it had been that of another person. There was no use in putting off the evil day, she said to herself, it would only make it harder, and so, when the great bells clanged out their harsh summons, she went out into the beautiful June morning, joined the crowd which streamed across the bridge, and before the last brazen tone had died away, preliminaries were arranged, and Thirza was in her old place again.

All through the long summer days Thirza labored on at the old work, with aching limbs and throbbing pulses. The unceasing din and jar, the invisible flying filaments, the hot, oily atmosphere, the coarse chatter of the operatives, wearied and sickened her as never before. Every evening she left the mill with a slower step; deep lines began to show themselves in her face, heavy shadows to settle beneath her dark, sad eyes. Poor girl! it was all so much harder than she had anticipated. The latent forces in her nature, which through all those years of toil, had never been called into action, were now, since her plunge into another phase of life, fully aroused, and asserted themselves in ceaseless clamor against surroundings. Besides this,—smother it, fight it, ignore it, as she might,—she was living in a state of tremulous expectancy. Again and again her heart had leaped at the sight of a figure in the distance, only to sink again into a dull throb of disappointment.

The fourth Sunday after her return, Thirza went to church for the first time. It was early when she arrived and people were just beginning to assemble. Many greeted

her warmly and proffered her a seat, but she refused all, taking one far back, and at one side where she could see all who entered. The seats gradually filled, but it was not until the last strains of the voluntary were dying away that Madison, senior, the great manufacturer, and his large complacent-looking wife came in, and with an air of filling the whole edifice, marched down to their pew in the front row. The music ceased. There was a rustling of silk which was audible in every part of the little church, and Warren Madison entered, accompanied by a stately blonde girl, elegantly attired. Queen-like she swept along, and Thirza saw, as if in a dream, the smile which she bestowed upon her escort as he stood aside to allow her to enter the pew, and she saw also his face, looking handsomer and manlier than ever. Then they were seated, and only the backs of their heads were visible. Thirza's heart stood still for a moment, and then began beating so wildly that she almost feared those around her might hear it. She went through mechanically with the simple forms the service required. She even tried to follow the thread of the Rev. Mr. Smyther's labored discourse, but there, between her and the pulpit, were the nodding white plumes and the yellow braid, and the brown shapely head and broad shoulders, and oh! so near together! Interminable as the service seemed, it came to end at last, and before the amen of the benediction had died upon the air, Thirza was in the street, hastening homeward.

The next day she stood at her loom, listlessly watching the shifting cloud-pictures in the midsummer sky, the glittering river, and the distant meadows and woods, and wishing herself away from the noise and the close air, and alone in some deep nook, where she could hide her face and think. A loud, confused mingling of voices, among which a high-pitched, girlish one was most conspicuous, rose above the clatter of the machinery, and drew her attention. She turned involuntarily toward the sound, and as quickly back again. That one glance had sufficed to show her Warren Madison, escorting a party of ladies through the mill. The blonde girl was there, looking, in her white dress, like a freshly-gathered lily. The party passed near her. She heard young Madison's voice warning the ladies to keep their draperies from the machinery; she heard the girlish voice in laughing answer, and, as they passed by, the same voice exclaiming, "Why, Warren, what a nice girl,

for a mill-girl! The dark one, I mean, by the window." Then there came a little whiff of violet perfume, and they had gone—he had gone! And, even in the midst of her humiliation and anger and self-pity, she could not but be thankful that he had thus passed her by, without a word. She could not have borne it—there.

The machinery roared and clattered and groaned, the air grew closer and hotter, the silvery clouds grew denser and blacker, and little puffs of wind blew in and fanned her feverish temples; and at last the bell sounded, and she could go. Away! no matter where, so that she were out of sight of everything and everybody, so that she could be alone with her own torn, wrathful, tortured soul. Straight through the town she went, up the hill beyond, and into the old burying-ground, where her parents rested. It was the only place, alas! where she was sure of being left alone; for there is no place so given over to loneliness and solitude as a country grave-yard. Here, among the quiet sleepers, where the grass and brier-roses grew rank and tall, and undisturbed, except now and then to make room for a new comer,—here she dared look herself in the face. And oh, the shame and scorn and loathing which that self-inspection produced! She threw herself down by the graves,—her graves,—and buried her face upon her arms. She lay there until shadows gathered about her, so still that the small brown sparrows hopped fearlessly across the folds of her dress and nestled in the grass beside her. At last she started up, and pressed her hands against her temples.

"I cannot bear it!" she cried aloud. "I thought I could; but I cannot! I must leave this place—this hateful, dreadful place—"

Was there a footstep near her in the dry grass, and was some one standing there in the dusk? She sprang to her feet and would have fled; but the figure came rapidly toward her. It was Warren Madison.

"You must pardon my following you, Thirza," he said. "I went to the house, and they told me you had come up this way. I came after you, because I have something I must say to you."

It was light enough for Thirza to see that he was very pale, and that his eyes were fixed eagerly upon her face. Trembling, bewildered, she made another attempt to pass him; but he seized her wrist and detained her.

"Thirza," he cried, "do not run away from me until you have heard what I have to say. Let me look in your face, and see if I can find what I thought I saw there when we parted that evening, more than a year ago."

He drew her toward him, and compelled her to meet his gaze. She tried to meet it with coldness and scorn; but she was weak and unnerved, and there was such pleading tenderness in his voice! She trembled, and sought feebly to withdraw her hand.

"Thirza, wont you listen? I love you! I have loved you so long—I never knew it until you went away; I never knew how much until I saw you to-day. I did not even know you had returned. Oh, Thirza, I could not have spoken a word to you before those people for worlds; but how I longed to snatch you up in my arms! If you had only looked at me, proud little statue in a gray dress!"

He compelled her to turn her face toward him.

"Thirza, was I mistaken? No, I was not!" and his voice was full of exultation. "I see the same look in your eyes again. You love me, my darling! There!" he cried, releasing her hands, "proud, cruel little woman, go! Leave me! Run away from me! I do not keep you; but, Thirza, you are mine, for all that!"

Hardly conscious of herself, Thirza stood before him, making no use of her liberty.

"Come, Thirza," said the shaking, passionate voice, "leave all the work and all the worry—your own words, darling; how often I have thought of them! Leave it all behind, and come here, to me!"

The clouds had parted, and the stars flamed out, one after another; and, as they were going home together through the starlight, the young man said:

"And did you live the 'real life' you anticipated, Thirza?"

She raised her shining face to his.

"It has just begun," she said.

TO SORROW.

COME not when the sun is here,
And the mock-bird, piping clear,
Warbles sweetest interludes,
And from wooded solitudes
Calls the flowers to appear.

Songless hedge and leafless tree,
Sorrow! are reserved for thee;
Therefore, call me not away—
Let me joy in life to-day!
Soon, alas! 'twill ended be.

Come when Winter comes again,
Bringing sadness in his train,—
On a wild and windy day,
When the rain, wet-eyed and gray,
Taps upon the window-pane.

'Neath the low, red sunset skies,
When the ghostly mists uprise,
Frozen marsh and pool among—
When regret o'erfills mine eyes,
I will go with thee along.

AMERICAN ARMS AND AMMUNITION.

"This is the Arsenal. From floor to ceiling,
Like a huge organ, rise the burnished arms.

* * * * *
When the death-angel touches those swift keys!
What loud lament and dismal Miserere

Will mingle with their awful symphonies!"—H. W. LONGFELLOW.

THE experience of Russia, in her recent contest with Turkey, has had an effect upon conservative military opinion which promises to result in serious modifications of the tactics of battle. Armed with an American rifle and American cartridges, the Turks accomplished extraordinary results with volley firing at distances ordinarily regarded as not to be compassed by anything except the fancy shooting of rifle ranges or the tentative practice of sharpshooters. Anywhere from a mile to nearly a mile and a half (1,500 to 2,500 yards) from the Turkish works, the Russians found themselves subjected to a fire so deadly that they speedily lost one-half of their effectives. General Zeddeler, who was with the Russian Guard at Gorni-Dubnik, reports that at 3,000 paces the Russians began to suffer loss, and at 2,000 paces were falling rapidly, the reserves, as the attack progressed, suffering nearly as severely as the firing line. Similar reports from Russian sources are common. An American observer, Lieut. F. V. Greene, an intelligent young officer of engineers, sent abroad by our War Department to record his experiences, relates the following incident:

On one occasion General Skoubeloff "found the men lying down and receiving the fire of the enemy without replying to it. Asking an explanation, the men replied that it was of no use to fire, for their guns would not reach the position of the Turks—about 1,500 yards off, across a ravine. While he was talking, his chief of staff was very badly wounded in the shoulder. Skoubeloff immediately ordered up a company of the 23d regiment, which he had armed with the Peabody-Martini rifles captured from the Turks. They had hardly opened fire before the Turks ceased their fire and retired behind the crest of the ridge."

To the gun, therefore, not to the Turk, are to be credited the extraordinary results which have elevated into a most important factor in the calculation of military possibilities the long-range fire, once supposed to be merely the amusement of experts. True, the employment of high-angle fire—or fire with the gun pointed midway between the zenith and the horizon—was one secret of the effect; but even where the Russians employed an equal elevation, they were un-

able, with the inferior Krenk rifle with which the majority of their troops were then armed, to secure a range anywhere approaching that of the Turks.

One of the most notable demonstrations of the Turkish battle-fields was the marked superiority of American arms and ammunition. The gun, of whose deadly long-range fire such reports are given, was the product of a workshop in Rhode Island, that of the Providence Tool Company; the cartridges, to which so much of its effect was due, were made in Connecticut,—at Bridgeport, by the Union Metallic Cartridge Company, and at New Haven by the Winchester Repeating Arms Company. Official investigation and private experience had, before this, satisfied experts of the superiority of our American manufactures of small arms; here the lesson was enforced by a most notable example in the view of all the world. Previous to the development of our arms manufactures, during our War of Secession, military as well as sporting arms were largely imported to this country, Colt's revolvers being the only American arms sold abroad to any extent. Since 1867 the tide has set the other way, and not far from one hundred millions of dollars have come to this country in payment for military arms and ammunition, the product of American factories. It was not without misgivings that an American manufacturer of guns, Mr. Samuel Remington, first undertook, in 1867, to compete on their own ground with the old established manufactories of Europe. The result is shown in the export of over a million Remington rifles and carbines since their first introduction to the foreign market. This, with the addition of nearly ten millions of dollars received for guns of other makers, and the sale of munitions of war, shows an aggregate contribution from a single arms house, since 1867, of over twenty-five millions of dollars toward the balance of trade in our favor.

Further contributions have been made by other manufacturers of arms and ammunition, among them, in Connecticut, the Colt's Arms Company at Hartford,

the Winchester Repeating Arms Company at New Haven, the Sharps Rifle Company, and the Union Metallic Cartridge Company at Bridgeport; in Massachusetts, the Ames Manufacturing Company at Chicopee, and the United States Cartridge Company at Lowell. The largest single contract awarded to any of these manufacturers was that given by Turkey for the guns and ammunition required to arm her troops for the impending contest with Russia. This contract, in the proportions to which it finally grew, was for 600,000 guns and three hundred millions of cartridges; altogether amounting to some twenty millions of dollars, divided in nearly equal proportion between guns and ammunition. Birmingham bid for it at a price barely sufficient to cover cost and contingencies, and allow a reasonable profit. Connecticut came in with a bid twenty per cent. lower and carried the work to America. Here, though war prices still prevailed, and labor and material were far higher than in England, the Yankee manufacturers were not ruined, as the English would have been at the price: on the contrary, they furnished far better work, and at the same time made the fortune of those concerned in the contract.

It is interesting to consider why this was so, especially as the investigation involves an inquiry into the superiority of our American workshops over those of every other country. Our manufacturers of arms have been pioneers in this improvement to an extent little understood. The superiority of American workmanship, and the cheapness of production in all departments of fine metal work, are directly traceable to the development of our arms manufactures. The lives of men and the honor of nations are in a measure dependent upon the skill of the armorer in his handicraft. Hence the special demand for accuracy in the details of manufacture in this department—a virtue which has extended to other branches of industry. Arms dealers have had the advantage, too, of selling to customers who were more solicitous as to quality and rapidity of manufacture than as to price. Immense orders and sure payment have justified any expenditure in fitting up factories, and stimulated ingenuity to the utmost to meet the call upon it. For example, two millions of dollars were invested by the Providence Tool Company in preparing to fill the Turkish order, and before the manufacturers were able to deliver the first thousand guns.

The stimulus of the War of Secession upon

the manufacture of arms was immense. In a single year (1863) the Government purchases of small arms aggregated 1,365,230, and our expenditures for armaments reached a total of forty-two millions of dollars. From January 1st, 1861, to June 30th, 1866, our Ordnance Department at Washington provided 7,892 cannon, and over 4,000,000 small arms, while the aggregate of cartridges and percussion caps mounted up among the inconceivable figures which measure planetary spaces—1,022,176,474 cartridges and 1,220,555,435 percussion caps. To these totals are to be added the purchases made for the navy, the entire expenditures for what are known as “ordnance and ordnance stores,” showing a grand total of two hundred millions of dollars. Of the Parrott rifled cannon, which did such excellent service on sea and land, over 3,000 were purchased, and projectiles for them to the amount of 1,623,000. War makes no account of the economies, and the loss and destruction of arms in a campaign are enormous; 665,327 Chassepots and 500,000 old pattern arms were used up by France in her war of 1870-71, and of 3,966,590 small arms provided by our Ordnance Department by manufacture and purchase from January 1st, 1861, to June 30th, 1866, five and a half years, 1,158,907 were lost, worn out, or rendered useless. According to the calculation of the Chief of Ordnance, the wear and tear during three consecutive years of service was twenty per cent.

The only armory left to the Government after the destruction of the one at Harper's Ferry, viz., that at Springfield, Massachusetts, expanded its dimensions during the war of 1861-5 until its product was increased from less than 10,000 muskets a year to over 250,000, with a maximum capacity for the completion of a thousand rifles in a single day. At least one of our private armories has a still greater capacity. While exerting themselves to meet an imperative order from France, during the war with Prussia, the Remingtons manufactured at Ilion, New York, twelve hundred military rifles in a single day, besides transforming three hundred muzzle-loaders into breech-loaders. Under the stimulus of unlimited orders from 1861 to 1865, private armories sprang up in all directions, tool and other factories turning their attention to the manufacture of arms and ammunition. Since the war some sales of military arms have been made by private manufacturers to the various states, but the main dependence has been on foreign

orders. Of the extent of the sale thus created it is impossible to give exact figures, without too close an inquiry into the mysteries of private business. Our statistics of exports do not show it. Governments purchasing contraband of war are not accustomed to advertise the fact, and the shrewd devices adopted to conceal the character of arms exports are best known to "the trade." Investigation would show that boxes labeled "Soothing-syrup," carried a surer sedative than Mrs. Winslow ever invented. Cases of supposed agricultural implements, and even innocent looking tierces of lard, have revealed to prying eyes the material of war on its way to the battle-fields of the world.

This much we know: the governments of Spain, Peru, Chili, Hayti, and Venezuela have purchased cannon of the West Point foundry, where our Parrott guns were

made, and from the same workshop went 73,000 10-pounder projectiles to be fired from the French guns at Prussian invaders. Spain and the Spanish South American Republics are armed with an American rifle, the Remington, and the same gun is in the hands of the Swedes, Norwegians, Danes, and Greeks. Egypt, China, and Japan are armed with them and the Chinese are making a clumsy imitation, good enough, as they explain, for drill purposes, and answering perhaps, in their imagination, like their tom-toms and paper dragons, to frighten the timid foreigner of the yellow hair.

The table which follows shows what countries have adopted the various breech-loading systems in vogue, and the cuts illustrate the principal American arms. It will be observed that when any country has so far overcome national prejudice as to adopt a foreign system, it has invariably

System.	Where adopted.	Description of the Breech System.
Albini	Belgium	{ Block pivoted at rear, at right angle to axis of chamber, and opening upward and forward.
Beaumont	Holland	
Berdan *	Russia	{ Block sliding backward in receiver, on a plane with axis of chamber, actuated by hand.
Carcano	Italy	Transformed bolt gun.
Chassepot	France	{ Block sliding backward in receiver, on a plane with axis of chamber, actuated by hand.
Dreyse	Prussia	
Mausier	Prussia	" " "
Peabody-Martini * and Martini-Henry *	Great Britain	{ Block pivoted at the rear, at right angles to axis of chamber, and falling forward within receiver, actuated by lever.
	Turkey	
	Roumania	
Remington *	Spain	{ Block rotating upon axis at right angle to axis of chamber, and opening backward.
	Holland	
	Egypt	
	Denmark	
	Sweden and Norway ..	
	S. American Republics	
Springfield *	China	{ Block pivoted at front, at right angle to axis of chamber, and thrown upward and forward.
	United States	
Werder	Bavaria	{ Block pivoted upon center, at right angle to axis of chamber, and falling forward, actuated by trigger under receiver.
Werndl	Austria	{ Block rotating upon axis parallel to axis of chamber.

In some countries two systems are in use, one being an older system not yet fully supplanted by the new. The American systems are indicated by an asterisk (*).

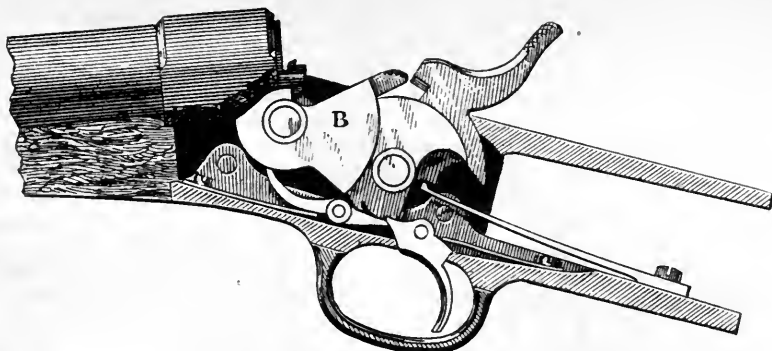

BREECH MECHANISM OF THE REMINGTON RIFLE.

been one of American invention. The bolt system—which was first introduced by Prussia in 1848, but which has never found favor in this country—is in general use on the Continent. France, Germany, and Italy use it exclusively, and Russia is putting it into the hands of her soldiers, a portion of her army having been already supplied with the Berdan. The breech mechanism in these several guns is constituted of the receiver or frame, the breech-block which closes the chamber when the gun is at rest, loaded or unloaded, and the locking mechanism which secures the block in its closed position. In most systems the breech-block is placed within the receiver, pivoted on an axis at the front or rear, and opens the chamber either by falling downward or being thrown upward and outward. In the several diagrams of systems, the breech-block is indicated by the letter B. The Turks have the six hundred thousand Peabody-Martini's for their infantry, and sabre bayonets and scabbards for them have gone from the factory of the Ames Manufacturing Company. The

Winchester magazine gun, the present representative of the Spencer Repeater, with which our cavalry was so largely armed in the closing years of the War of Secession, is in the hands of the Turkish cavalry. The Russians have adopted an American system, the Berdan, for the re-armament of their infantry; following the German and French in taking a bolt gun. The English, besides complimenting us by appropriating our Peabody system, adding to it the device of the Swiss, Martini, and re-christening it, with the addition of the Henry rifling, as the "Martini-Henry," have taken in one order 300,000 Colt's revolvers, and are manufacturing our Gatling-machine gun under a royalty. The Smith and Wesson revolvers have also been sold largely abroad, and the original Colt's have been in use the world over. At the Colt's armory, one of the most costly and complete in its appointments in the world, are manufactured the Gatling gun, the original of the mitrailleuses, now universally accepted as a necessary part of modern armament. Over 3,000 Gatlings, costing almost

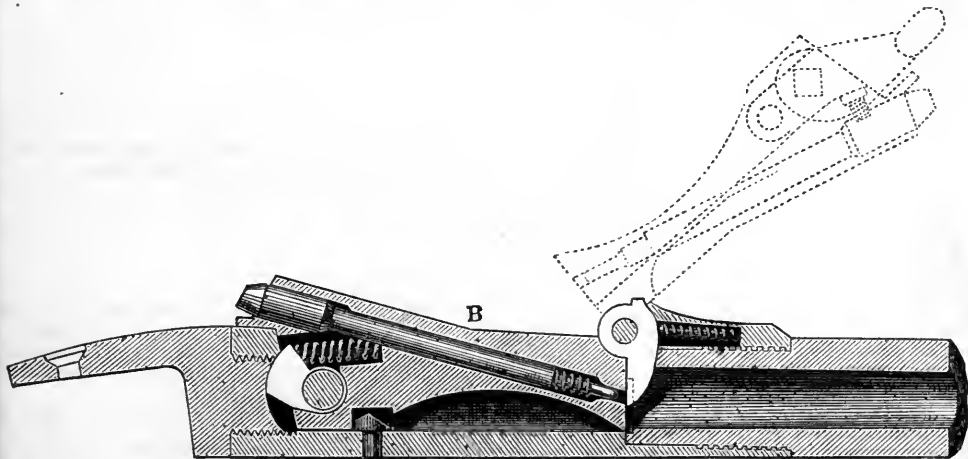

THE SPRINGFIELD SYSTEM.

four millions of dollars, have been distributed over the world, and Russia as well as England manufactures them in her own armories on

of the Gatling are shown in the cut. It consists of a circle of from five to ten rifle-barrels revolving on an axis, and by their

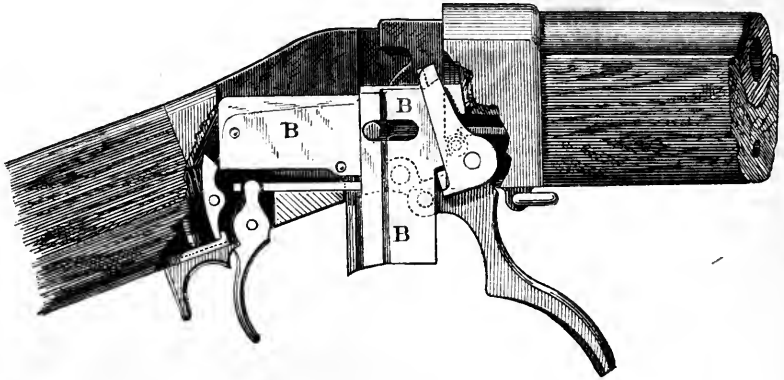

THE SHARPS RIFLE.

a royalty. The Gatlings figure in reports of all English military operations, and they have done excellent service of late in engagements with the Zulus and Afghans. The inventor of this gun is a physician from North Carolina, Dr. Gatling, who has un-

successful discharges keeping up a continuous and most destructive fire. It is operated by a crank, turning on a pivot, like the handle of a grindstone.

To the millions expended here on munitions of war must be added the other mil-

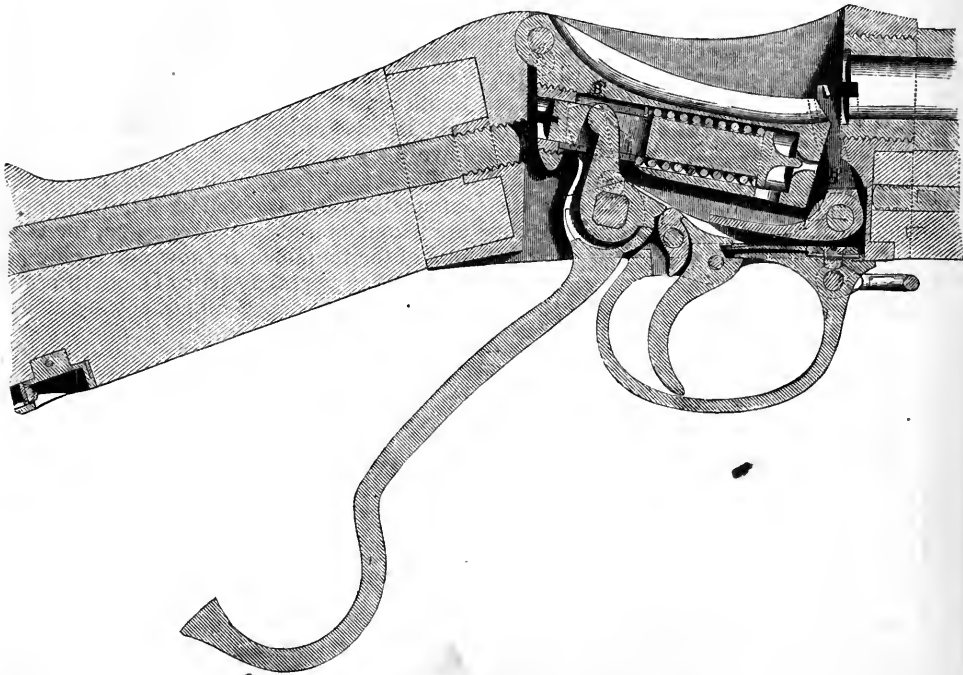

THE PEABODY-MARTINI.

dertaken the practice of phlebotomy on a scale that would excite the envy of a physician of the olden time. The peculiarities

ions sent across the Atlantic for the purchase of American arms machinery and tools. England and Russia long since fitted up

their government arsenals from this country, to a greater or less extent: the Birmingham Arms Company and an Armory near Woolwich have taken their machinery from the Ames Company. Spain and Egypt have bought theirs from the Remingtons. Prussia, coming late into the field, has been even more thorough in the adoption of American machinery. In 1873 she gave an order to the Pratt and Whitney Company at Hartford for gun machinery and tools to the amount of a million and a half of dollars. Three years were required to complete the machinery and set it in operation in the three royal armories, and American workmen were sent over for this purpose. Two hundred thousand Mauser rifles are manufactured with it annually. As a saving of fifty per cent., or five dollars a gun, is made, as compared with the old method, the "Yankee notions" must have paid for themselves within two years. The fact of this saving is certified to by the Prussian government in a written document, shown with honest pride by the Connecticut manufacturer. Not only has the introduction of American methods proved thus profitable to the royal treasury, but it has established a school for German artisans whose influence will be felt in other departments of manufacture. The introduction of American machinery into the royal arsenals of Prussia was an event certain to attract attention in German workshops.

"Why," the American contractor was frequently asked, "why is it that Americans have become such experts in the use of tools?" In reply, attention was called to the independent position of the American workmen, who calls no man master, to the stimulus given to invention by the high price of labor, and the protection afforded at a trifling cost by our patent laws. Whatever the disadvantage we have appeared to suffer from the justice which has accorded to the workingmen in this country a position of comfort and independence, enjoyed nowhere else in equal degree, it has, in the end, resulted to our advantage. A control of foreign markets obtained by developing the intelligence of our artisans and increasing the perfection of our ma-

chinery, is not to be easily disturbed by competition founded upon any less perfect system of production.

The reduction in cost of arms manufacture has not been obtained at the expense of quality. It has, on the contrary, been accompanied by a steady improvement in workmanship. The use of machinery compels the employment of better material. At his examination, in 1852, before the Parliamentary Committee in England, Colonel Colt, the inventor of the revolver, was shown a Minie rifle, presented as a superior specimen of French handicraft.

"Do you consider," he was asked, "that

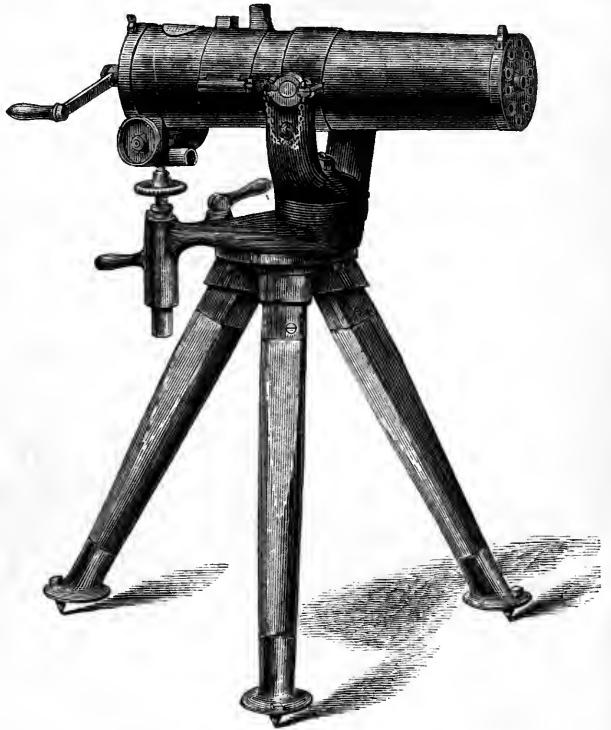

THE GATLING-MACHINE GUN.

the muskets made in the United States equal this?"

"There are none so badly made at *our* armories," was the reply. "That arm could not pass any of our inspectors."

This was no idle Yankee boast, and it was equally true of the Enfield-made breech-loaders, sent to the Providence Tool Company twenty years later as models to be followed in fulfilling the Turkish contract. These were so improved upon that Turkey has secured a much better arm than that used in the English service.

The reason is simply this: though the

Enfield guns were honest and strong in workmanship, and made of excellent material, as are most English productions, even their model arms show a lack of finish not to be tolerated here, where the perfection of automatic machine-work is obtained, at a far less cost than the less perfect hand-work. As Colonel Colt stated on the occasion referred to, it cost then less in the United States to complete a gun-stock than it did in England to buy the wood for one.

A recent newspaper paragraph has recalled the ridicule with which Parliament received the proposition to make the first essay in the introduction of American methods, by the purchase of Blanchard's American gun-stocking machinery. The idea that the Americans were surpassing the English in gun manufacture was really "quite too amusing." An English expert was sent over to investigate. He brought with him three rough stocks, of the toughest timber he could find, certain that they would prove too much for the machine, intended, as he supposed, for the American soft woods. Concealing his purpose, he asked the overseer of the Springfield Arsenal to run them through the machine. Much to his surprise it handled them all the better because of

their hardness. The result was that an order was left at Chicopee for the Blanchard machine, and the accompanying machines, six or eight in all, to be sent to England, where they have since been in use.

The machine referred to, the invention of Thomas Blanchard, was originally patented January 20th, 1820. It was first brought into use at the Government Arsenal, Springfield, and is now in use in all armories in this country and Europe. Originally intended only for turning gun-stocks, it has since been adapted to the turning of irregular forms of all sorts, such as piano legs, bat clubs, and the like. The cutters, operating upon the wood in the lathe, are guided by a friction-wheel, passing over the inequalities of a pattern turned to the exact shape of the object to be produced. This wheel precisely regulates the motion of another wheel, armed with chisels, which are brought to bear upon the rough block. Thus as the friction-wheel successively traverses every part of the rotating pattern, the cutters pare away the surplus wood from end to end of the block, leaving a precise duplicate of the model. This machine not only shapes the stock, but mortises and bores the curvatures for the lock, barrel, ramrod, butt-plates, and mountings. Several

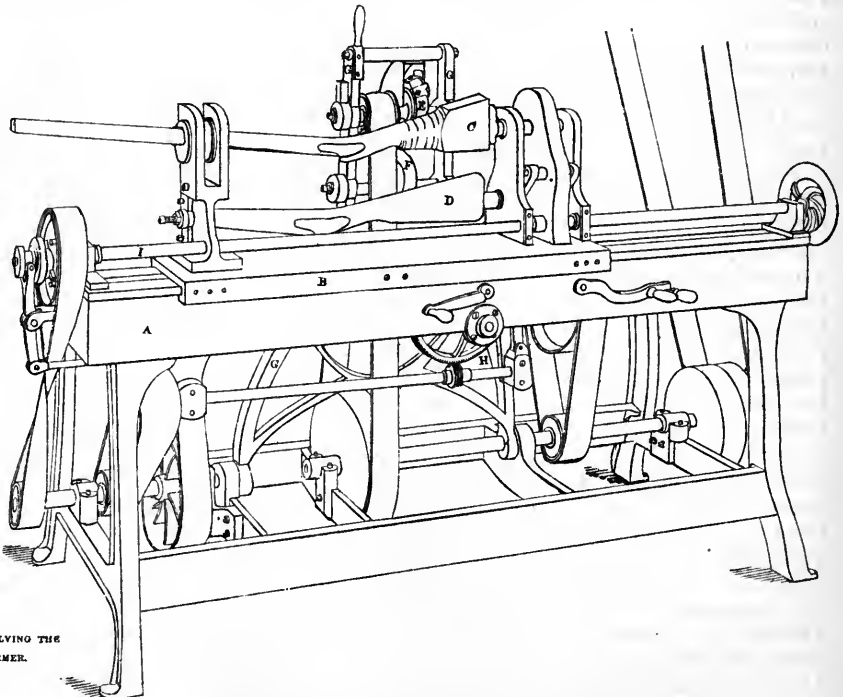

LEGEND

- A.—FRAME.
- B.—CARRIAGE.
- C.—GUN STOCK.
- D.—FORMER.
- E.—CUTTER HEAD.
- F.—GUIDE WHEEL.
- G.—SWINGING FRAME.
- H.—FEED MOTION.
- I.—SHAFT FOR REVOLVING THE STOCK AND FORMER.

MACHINE FOR TURNING STOCKS.

of these machines have recently been sent to Japan by the Ames Company.

Though armories everywhere have been compelled to avail themselves of American invention, nowhere has the use of machinery reached the development that it has here. Out of 800 men employed by the National Arms Company at Birmingham, in 1875, 110 were found to be at work with hand-files. A comparison with a similar armory in this country showed that of 1,600 men but 11 were filers, or one-twentieth of the proportion employed in England. Forty years ago, it is to be noted, a large part of the work on guns made in this country was done by the hand-file or on the grindstone. Year by year machinery has been adapted to new uses, until hand-work has become almost unknown. So entirely are iron, steel, and wood reduced to their final proportions by the positive and regulated action of drills, reamers, broaches; and cutters of various kinds, that in a thoroughly organized armory the operations on an arm, from the minute when the material first encounters a machine, are exactly numbered, as well as classified. These operations are termed "cuts," and the amount of work required for the production of a particular arm is indicated by the number of cuts needed to complete it. Each succeeding process is the well judged result of careful experimenting, directed to the end of economizing labor, and perfecting either shape or size. With the present efficient and exact machinery the final process leaves the part so perfectly finished that a file is seldom needed.

The American genius for organization is well shown in the distribution of work at the Providence Armory, which we take as an example of American armories. In an English armory all of the employees are placed under the direction of a single superintendent, and he is held responsible for the work in all of its details. In the large private armories in the United States it has been the custom to divide the work among contractors, to whom the labor upon the several parts is distributed. The armory provides the raw material, the shop room, machinery, power and tools, which last the contractor is expected to return in good order, an exact account being kept with him of the cost of tools and material. The contractor hires his workmen, takes care of his rooms and machinery, and turns out the parts given to him. These, before being accepted, are subject to a rigid inspection, which, in the case of

a government contract, is conducted by officials.

The largest operations can be easily carried on under such a system as this, so as to secure the most perfect workmanship at the least cost. The contractor is a man of special ability and experience in the particular line of production which he undertakes. Receiving so much per piece, and being held to a strict accountability for quality, he gives his whole thought to the direction of his work, to the employment of the best artisans and to the invention and application of new machinery, processes, and tools—in a word, conducting the department with as much economy and skill as if it were his own. Thus, in executing a large order, one device after another for economizing work, reducing the number of "cuts," or imparting a better finish, discovers itself. Though the contractor receives a given sum for his work, he is required to render an account of his expenditures, and the factory gains ultimately the advantage of any reduction in the cost of production. Not a few of the marvelous labor-saving processes that distinguish American mechanical production are the result of the contract system in our large workshops. In contrasting this system with that which prevails, even in this country, in manufactories of textile fabrics, it should be borne in mind that the manufacture of guns, and other machinery, consists in the fabrication of a multitude of distinct parts, each of which has its individual character and cost to be considered. The government arm, the Springfield, has sixty-eight separate parts, sixteen of which parts are screws of one sort or another, and nine of them springs. The constant changes and improvements in the manufacture of these parts is shown by the fact that, of them all, only four remain as they were in the original model of 1855, so as to be interchangeable with the corresponding parts of the present arm.

An essential part of the system we have suggested is the use of gauges to test the accuracy of the work as it progresses. The mechanical definition of the gauge is "any instrument used to measure." It may be a pattern from which the manufactured part has taken its shape; a plug to fit exactly a tube and determine the correctness of its dimensions; a cunningly precise instrument to determine the alignment of sights, or a combination of screw work, Vernier scale, and expanding profile, to indicate the slight-

est variation from the true form for a breech-chamber.

The Peabody-Martini gun has sixty-nine parts, and for each part a set of gauges is provided, not omitting even the smallest screw. The double set of gauges to accompany the machinery for making two hundred needle guns per day in the Prussian arsenals cost nearly fifty thousand dollars, and the amount expended by the Providence Tool Company in perfecting their system of gauges was a fortune in itself. Not only was the first cost very large, but the most accomplished artisan known to the company was employed to superintend a force of eighteen expert mechanics, whose duty it was to see that the gauges were kept up to the standard. Of each gauge or set there were two, a maximum and a minimum, the rule being that a part should not be less than the minimum or up to the maximum. Not only was there a double set of gauges for each part, but each of the 826 cuts required to complete the arm was tested by its peculiar standard. The preservation of the gauges is a most important matter. The standard set was kept carefully locked up in a special safe, as large as a good-sized room. To each contractor was furnished a partial set from which he worked, and another set was divided among the inspectors of the various parts. The gauge used to determine the caliber of the chamber was renewed daily, to avoid even the infinitesimal change in its proportions, resulting from the slight friction to which it was subjected.

The superior quality and marked uniformity of the military arms made in the United States, are due, in part, to the thorough system of inspection to which they are subjected. By the courtesy of our War Department, the foreign governments, who have purchased so largely during the past fifteen years of our American armories, have been able to make use of ordnance officers and experts from one of the national arsenals as inspectors of finished arms. Among the bills passed at the last session of Congress was one authorizing a young ordnance officer, Lieutenant Henry Metcalfe, to accept a decoration bestowed upon him by the Turkish government for such services. During the execution of the great Turkish contract, at one time nearly fifty inspectors were employed under his direction in the examination of the guns, besides the twenty-six Turks overlooking their work. The inspection at Providence was more thorough than any previous one, and examination of

any one of the Turkish Peabody-Martinis used in the late war with Russia, would show upon each of its sixty-nine parts, two impressions of a minute stamp, indicating that the United States examiner had subjected it to careful observation and tested it by gauge.

As an example of the thoroughness of inspection, take the barrel, which goes through ninety-five consecutive processes in which sixty-seven different machines are used. The first inspection is made after the barrels are proved for strength. A hundred barrels are screwed firmly in a frame, each loaded with 205 grains of powder and 715 grains of lead, these barrels being fired by train. It is to be remembered that the regular cartridge for service contains but 85 grains of powder and 480 grains of lead. At the Government Arsenal at Springfield, forty barrels are loaded together, first with a 500 grain slug and 280 grains of musket powder, and then with a slug of the same weight and 250 grains of powder. The next inspection is made after the interior of the barrel is finished, preparatory to rifling; another after the barrel is rifled; again when it is completed, and finally after it has been browned. The gauges used in the final examination are of the finest construction and scientifically accurate. The deflection of the 1000th part of an inch in the sighting of an arm can be detected. Without such accuracy the wonderful records of the crack riflemen at Creedmoor would be impossible.

To the chamber of the gun is applied a most exhaustive system of inspection. At Bridgeport, in testing cartridges, some thirty thousand rounds were fired from a Peabody-Martini. As a matter of curiosity the gauges were subsequently applied, and an enlargement of one thousandth of an inch near the cartridge head was the only change that could be detected. According to the estimate of our ordnance officers the barrel of a rifle will endure at least ten thousand service fires before its accuracy is sensibly impaired, and its exterior dimensions may be very much reduced by wear without impairing its strength for service.

The most exact inspection is, of course, given to the barrel and the adjacent breech action. The inspection of the other portions of the gun is thorough, though less difficult. After the parts are assembled into guns, each piece is carefully tested to see if its parts are well adjusted and interchangeable without difficulty, and finally

the work of the inspectors is itself passed upon, the last inspector examining every part to see that the official stamp of approval has been impressed upon it.

Seventeen hundred and fifty-eight machines constitute the working plant for the manufacture at Providence of 800 arms per day, three rolling-mills being employed. The loss in the process of rolling has been but one-tenth of one per cent. and about two and a half per cent. in the progress of the finished barrel.

The stocks of a gun, made of black walnut, are first sawed into a rude outline of the shape they are finally to assume, before

thirty-three inches, by being drawn, while heated, through grooves, gradually diminishing in size. The machine for this work is shown in the cut. It has eight tapering grooves. In connection with the grooves are used eight mandrels, or iron rods, which vary in diameter from three-quarters to twenty-seven hundredths of an inch. Passing the largest rod through the barrel mold, which has been brought to a red heat, the workman places the mold into the first of the cylindrical grooves. This draws it over the rod as it runs through. Rods gradually decreasing in size are used for the succeeding grooves, until the barrel is extended to the

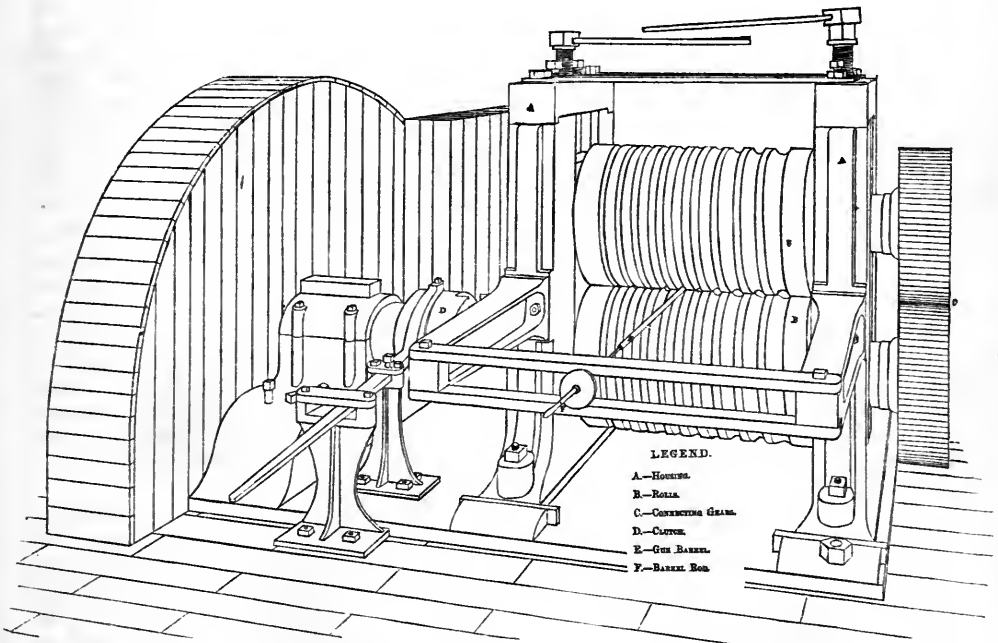

BARREL ROLLS.

being subjected to the operations of turning, grooving, etc. The wood is carefully examined to see that it is straight-grained, well-seasoned, and free from sap and wormholes. A practised nose will detect the smell of unseasoned wood as unerringly as the scent of a trained hound discovers the quarry.

The barrel of a rifle first presents itself as a cylinder, or mold, of decarbonized steel, two inches in diameter and but nine and a fourth inches in length, with a hole three-quarters of an inch in diameter through its entire length. It is reduced to the required dimensions, and extended to the length of

proper length, and reduced to the proper caliber for rifling. The cylinder is reheated, after passing through each groove; until the last one, through which it is passed three times to give the required form.

The caliber of military guns during the Revolution, seventy-five hundredths of an inch, has been reduced by successive stages until it is now but forty-five hundredths. Down to 1866 the caliber of the Springfield musket was fifty-eight hundredths. In 1866 it was changed to fifty hundredths, or one-half of an inch, and again in 1873 to the present caliber of forty-five hundredths. The length of the barrel, originally forty

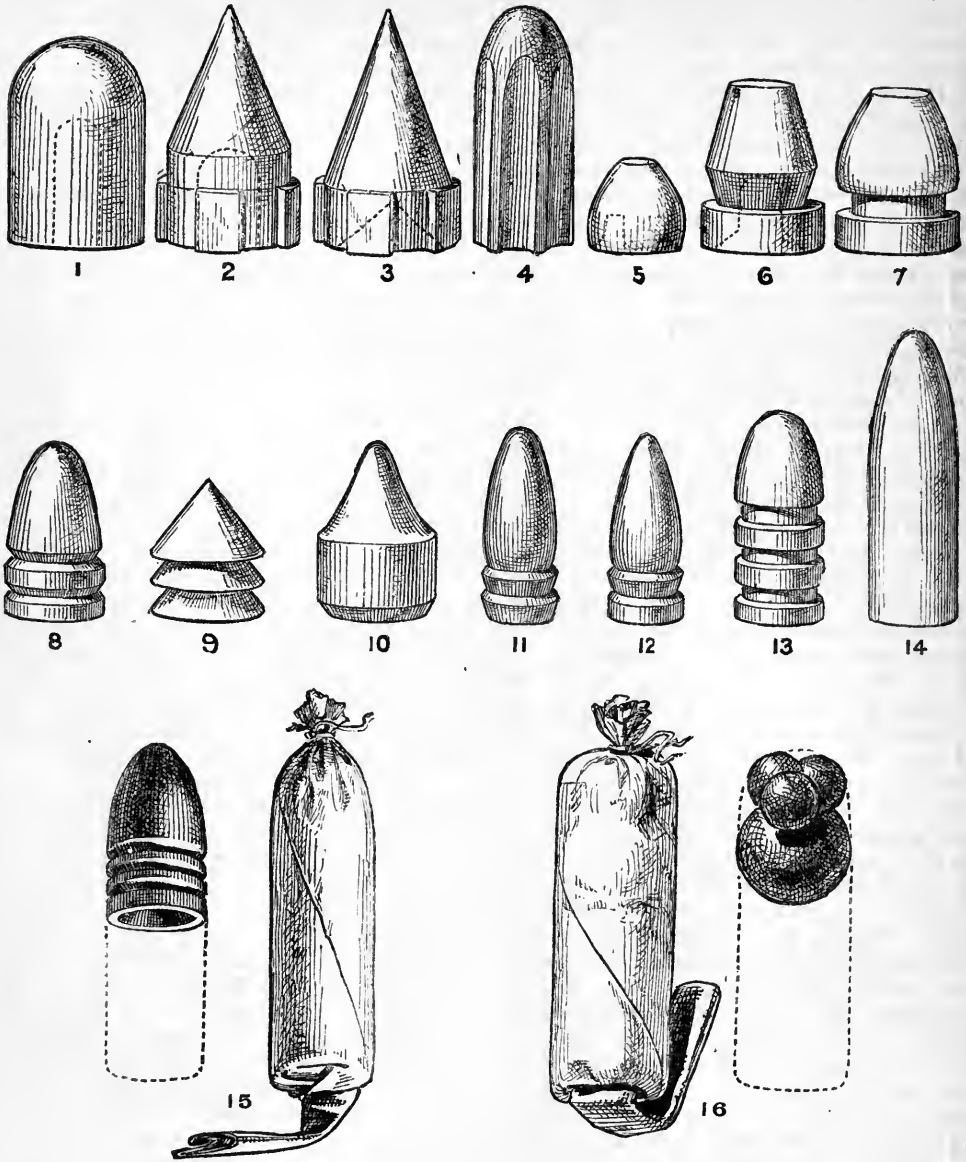

CUTS SHOWING PROGRESSIVE CHANGES IN BULLETS AND THE OLD PAPER CARTRIDGE.

inches, has been reduced to thirty-three and a quarter inches. The bullet has meantime gone through various mutations until it has arrived at its present shape. The cuts indicate some of the stages in its process of development from the original round bullet. The first three represent the original Minie ball, with an iron cup in the base, and as improved and used without cups. No. 4 is the Whitworth bullet hexagonal in shape. Nos. 5, 6, and 7 are bullets used by France during, and immediately after, the

Crimean War. Nos. 8 and 9 are German bullets and No. 10 a Sardinian bullet. Nos. 11 and 12 are Swiss bullets. These are old patterns. The bullet at present used in our military service is shown in No. 13, and the bullet for long-range firing in No. 14. With these are also shown (Nos. 15 and 16) the now discarded paper cartridge, with a Minie bullet, and the buck-and-ball paper cartridge. It was found that no globular ball could be depended upon beyond 300 or 350 yards. The present elongated bullets are

capable of giving a range of nearly ten times that with the amount of powder in actual use for military arms.

It is to France that we owe the first suggestion of the plan of using dies for forging steel into any desired shape, and making the corresponding parts of different guns so exactly alike that they are interchangeable. But these ideas, after they had been abandoned in France as impracticable, were taken up here and improved upon until they were practically new. Eli Whitney, whose cotton-gin enthroned the southern staple, took the first step in this direction. Whitney was the first successful manufacturer of arms in this country after the Revolution, during which this industry flourished. Disgusted with his treatment in the cotton states, where neither law nor public opinion could secure to him any requital for his labors, he sought a new field for his talents. In 1797, acting upon the suggestion of Thomas Jefferson, whose foreign travels had probably made him familiar with the French experiments in the direction of interchangeability in the manufacture of arms, Whitney was persuaded to try his fortunes as a gunsmith. A contract for ten thousand small arms was secured for him, through the influence of Oliver Wolcott, the Secretary of the Treasury. Other manufacturers who entered into contract with the government at the same time, followed in their workshops the processes pursued in England. These involved a dependence mainly on manual labor, and the result was ruin. Whitney alone seems to have had the inventive genius to originate new methods, or, at least, to develop those already suggested by the French. Where they failed he succeeded so far that since his time no American military arm has been completed without the use of forging for many of its parts, and this process is not only in use at our armories, but is a leading operation in all of our metal manufactories. A solid block of low steel is forced into a die by the weight of a trip-hammer, and made to assume almost any shape desired.

Whitney made a great advance, also, in the application of machinery to the work of finishing the parts after they were swedged, or formed in the rough, thus abolishing to some extent, even at that early day, the slow hand-work of filing or grinding on a wheel. The milling machine, which by the use of revolving cutters shaves off rough surfaces and shapes irregular or eccentric contours, if not his original invention, was

developed by him and introduced into gun manufacture. Whitney introduced, too, the system of gauges by which uniformity of construction is insured for parts made after the same model. Finally, he discovered and applied to his special work that principle of division of labor which lies at the foundation of all modern industrial progress. By organizing a continuity and logical relation of processes, he was enabled to distribute the operations on the various parts of a gun among different workmen, thus securing a perfection of workmanship impossible under the system which entrusted the completion of an entire arm to a single man. Says his biographer, Professor Olmstead: "He reduced a complex business, having many ramifications, almost to a mere succession of simple processes, and was thereby enabled to make a division of the labor among his workmen on a principle not only more extensive, but altogether more philosophical, than that pursued in the English method. In England the labor of making a musket was divided by making the different workmen the manufacturers of different limbs, while in Mr. Whitney's system the work was divided with reference to its nature and several workmen performed different operations on the same limb."

In 1812 John H. Hall invented a breech-loader, which was manufactured under the orders of our government and issued to troops for trial as early as 1816, or half a century before the needle-gun made itself famous. In his letters to the War Department, Hall laid great stress upon his plan of making "every similar part of my gun so much alike that it will suit every gun; that if a thousand guns were taken apart and the limbs thrown promiscuously together in a heap, they may be taken promiscuously from the heap and all will come right." How far Hall went beyond Whitney in the application of this principle we do not stop to consider. It has certainly been greatly developed on this side of the Atlantic. This principle of interchangeability of parts was first applied to government service by Hall at Harper's Ferry, in 1818, and it finally established itself as the rule of the government workshops. The Mexican war showed how much was gained by a system which enabled an armorer to carry with him to the field duplicate parts with which to restore a disabled gun to service.

Thomas Blanchard, of Middlebury, Mass., carried the improvement in the manufacture of arms a step beyond either Whitney or

Hall, by his invention, or application, of the lathe for cutting away and shaping the exterior of the barrel, followed by the far more important device of the automatic wood-cutting or stocking machine already alluded to. With this last invention, and a constant improvement in the swedging and milling processes, the manufacture of arms has gradually advanced to its present independence of handwork—now almost complete, and yearly becoming more so.

The progress of invention is well illustrated by the fact that Blanchard's original lathe for shaping the stock, by subsequent

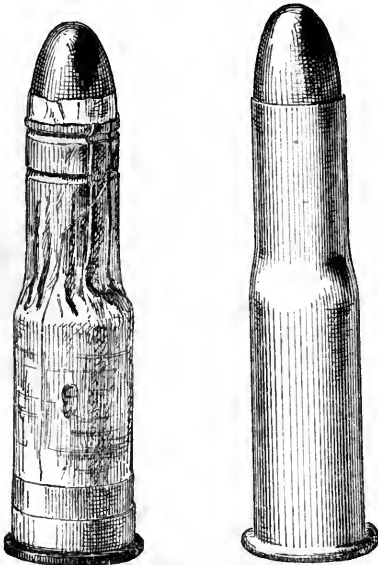

ENGLISH MANUFACTURE.

AMERICAN MANUFACTURE.

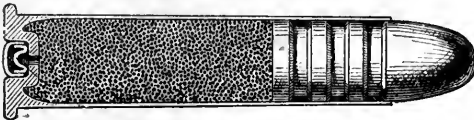

CROSS SECTION OF CARTRIDGE SHOWING INTERIOR.

invention was developed into a series of seventeen machines, since reduced, through the combination of processes, to thirteen. The result in the reduction of cost is shown by the statement that the sandpapering operation, still performed by hand upon the perfectly shaped stock, requires more men and costs more money than all the machine work. The sandpapering has been done to some extent by revolving machinery, but a satisfactory result has not yet been reached.

A further and most important step in the improvement of breech-loading arms was the invention of the metallic cartridge, in the manufacture of which the Americans

still lead the world. A comparison of the cartridge heretofore manufactured in England for the Martini-Henry rifle, with the cartridge manufactured here for the Turkish arm of the same pattern, makes this superiority at once apparent. They are shown in the cuts on this page.

Russia was among the first to make use of the American metallic cartridges, and she attempted in vain to imitate them. After wasting ten millions of cartridges made of inferior material, she wisely concluded to buy here, as other foreign nations have since done. Some of the American cartridges sent to Russia were subjected to the unparalleled test of a five-weeks soaking in the waters of New York harbor, the vessel carrying them having sunk off Staten Island on her way out. They were fished up as good as new, and, triumphantly passing the ordeal of a new test of their firing quality, went on their way again, and have no doubt long since added their quota to the return of casualties. For good cartridges American copper is needed, a fact which the Europeans are beginning to learn. Even so long ago as the days of the mound-builders, it was discovered that our Lake Superior region produced a copper ore of uncommon purity. Ore of equal purity is not, it would seem, to be found elsewhere, and perhaps the process of annealing is not so well understood abroad. At all events, the brass made of the foreign copper, abounding in the sulphurets, lacks the necessary strength and ductility, and for some reason the metallic cartridges made abroad are liable to deteriorate in quality. During her war with Turkey, Russia purchased large quantities of brass here, one Connecticut firm alone supplying two millions of dollars worth of sheet brass. Other governments have, no doubt, been purchasers. Ready-made cartridges have also been sent abroad in such quantities that a million has become the unit of calculation. Three forms of cartridge are given in the illustrations on page 449, one showing the United States government cartridge, another the Peabody-Martini cartridge, and the largest the Sharps or Remington special long-range cartridge. The government cartridge contains 70 grains of powder and a hardened bullet, composed of one part of tin and sixteen parts lead, weighing 405 grains. The Peabody-Martini has 85 grains of powder and a bullet of the same composition weighing 480 grains. The long-range bullet has one part of tin to fourteen parts lead, and



2,100 yards were found effective. The rifles with which our own army is provided are sighted to 1,200 yards, as will be seen from the cut on page 450, showing the military sight. Some of the sights used by riflemen in long-range shooting are also shown; the Vernier sight, and a sight combining a spirit-level and wind-gauge. The ordinary Vernier

weighs 550 grains, the charge of powder being 100 grains. The advantages of the heavier cartridge are well shown in the experiences of the Turkish war already referred to. Whatever else they may lack, the Turks have certainly shown superior intelligence in the armament of their troops. The English, who use the same gun, had, on a smaller scale, an experience similar to that of the Turks. The rifles used by the rifle brigade in the campaign against the Afghans were sighted for 2,000 yards, and at

will register to the thousandth of an inch, and Verniers have been made so as to register the twenty thousandth of an inch, these finer sights being used to regulate the ordinary sights. These very fine sights are not adapted to military service, in which the rifle is subjected to a very different usage from that prevailing at Creedmoor, where the long-range rifleman is able to give his weapon all the care that a musician would take of his precious Stradivarius violin or his Tourte bow.

It is not to be understood, from what has been said, that long-range firing, such as the Turks have astonished us with, has yet approved itself to military conservatism.

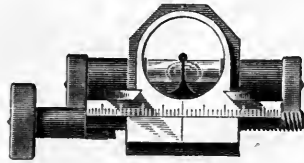

WIND SIGHT AND SPIRIT LEVEL.

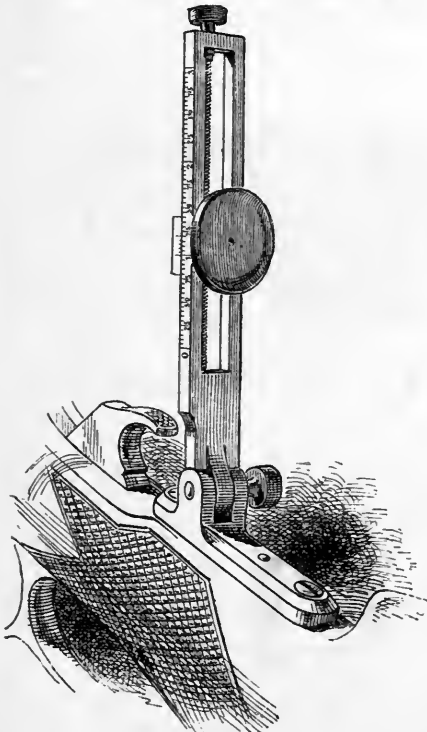

VERNIER PEEP SIGHT.

Nevertheless, as the organ of the French general staff has recently declared, those who object to the use of the new expedient in warfare should at least "range themselves by the side of its convinced partisans," so far as to consent to participate in experiments with what it might be most inconvenient to know nothing of on the day of battle. Accordingly, a most elaborate and successful series of experiments has been undertaken at Chalons with skirmish-fire, squad-fire, and platoon and company fire, at distances of from half a mile to a mile and a quarter (800 to 2,000 yards). Germany is conducting similar experiments at Spandau, as Austria did before her, in 1877, at Vienna.

The tendency of military change in small arms is in the direction of magazine guns or repeating rifles, which were used to a very considerable extent in the later years of our own war. Though Turkey has armed her cavalry with the repeater, thus far Switzerland is the only country which has actually adopted it for infantry. France has taken

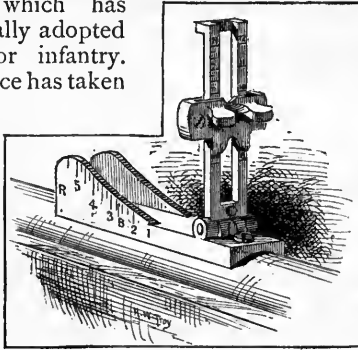

SPRINGFIELD REAR SIGHT.

the Kropatschek, the invention of an Austrian officer, for her navy, and Austria is experimenting with it, having already armed her *gendarmerie* with another repeater, the Fruwirth. Norway has introduced the Krag-Petersen into her navy, and our navy is experimenting with the Keene gun. The

box, or cartridge-holder, carrying five cartridges pressed down upon a spring shaped like the letter W reversed. The breech action releases this spring and throws the cartridges, one after another, into the barrel of the gun. These cartridge-holders, costing a few cents apiece, are to be thrown away in action, as fast as emptied, and new ones inserted. It will be seen how rapid the action, and how effective the fire from such a gun must be with an unlimited supply of cartridges. The Lee gun has not yet approved itself in actual service but was recommended for trial by the last Army Equipment Board at Washington, presided over by General Nelson A. Miles, who has since asked that it should be issued to his troops.

The different forms of magazine guns are shown in the cuts. A is the loaded magazine or receiver; B, the breech block; C, the passage from the magazine to the barrel; and D, the "cartridge follower" or spring for throwing the cartridges into position for loading. The Hotchkiss, adopted for a trial in our service, carries five cartridges in a magazine in the butt. The Winchester repeater, which has thus far had the field for magazine guns almost entirely to itself, carries in a tube, extend-

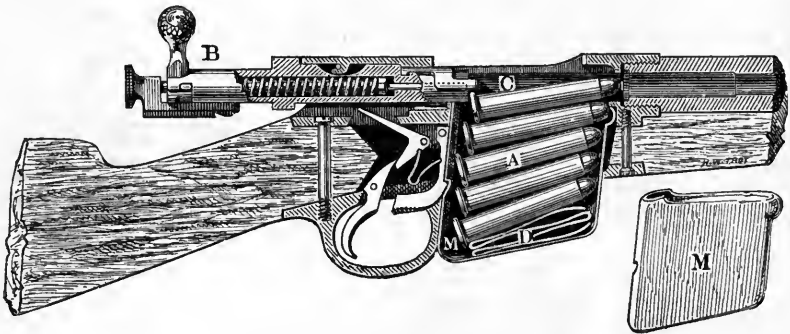

THE LEE DETACHABLE MAGAZINE GUN.
M is the tin magazine detached.

objections to the magazine gun have heretofore been the additional weight of the magazine, the necessity of using a lighter cartridge, and the constant shifting of the balance of the gun as the magazine was emptied in firing. All of these difficulties the Lee gun, the latest invention, seeks to overcome. It introduces the idea, before suggested but never thoroughly tried, of a detachable magazine, inserted in a slot in the breech frame. This magazine is nothing but a slight metal

ing under the barrel, seventeen cartridges, which are pushed along by a spring. The Hotchkiss and Winchester are both manufactured by the Winchester Repeating Arms Company. The Keene magazine gun, manufactured by the Remington Arms Company, resembles the Hotchkiss in being a bolt-gun and the Winchester in the location of the magazine. The fact that the Hotchkiss gun had not passed through the preliminary stage in the hands of troops before

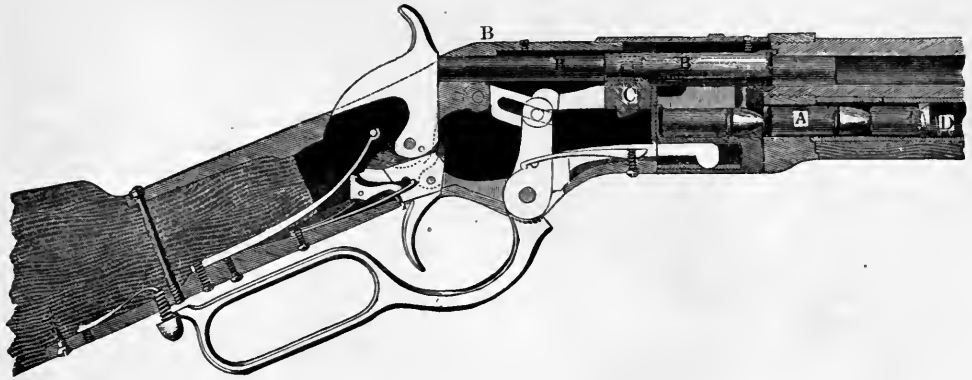

THE WINCHESTER MAGAZINE GUN.

a new board recommended the Lee gun, shows how difficult it is to keep an army abreast of the constant changes and improvements in small arms. Another recommendation of General Miles's board was in favor of the adoption of what is known as the Rice Intrenching Knife bayonet, the invention of an officer of the Fifth U. S. Infantry, Brevet Lieutenant-Colonel Edmund Rice. This seeks to combine the bayonet, knife, and intrenching-tool in one weapon. The Turks, who have been our instructors in the art of intrenching since the days of Vauban, have, in connection with their recent illustration of the capabilities of American arms, shown the advantages of that dirt-digging of which such use was made in our own experience of war on a large scale. With the present "hard-hitting, far-reaching, and rapid-firing arms of precision" some means of rapid intrenching becomes imperatively necessary.

would be made in such an article as this to give anything like a complete or exhaustive description of the arms industry in this country. The design has been merely to convey some general idea of its past growth and its present commercial importance. Considering it chiefly in its relation to foreign armaments, the work of our national armory has been only incidentally alluded to. It is well to remember, however, that the nation now has over sixty millions of dollars invested in the national arsenals. It is an open question whether the power thus placed in the hands of our Ordnance Department, to compete with private manufacturing should be allowed further extension. Certainly, it would be a great misfortune if an industry to whose development the country owes so much, and which is so important in its relations to the public defense should at any time be crippled for want of the aid of government purchasers in the open market. The system of govern-

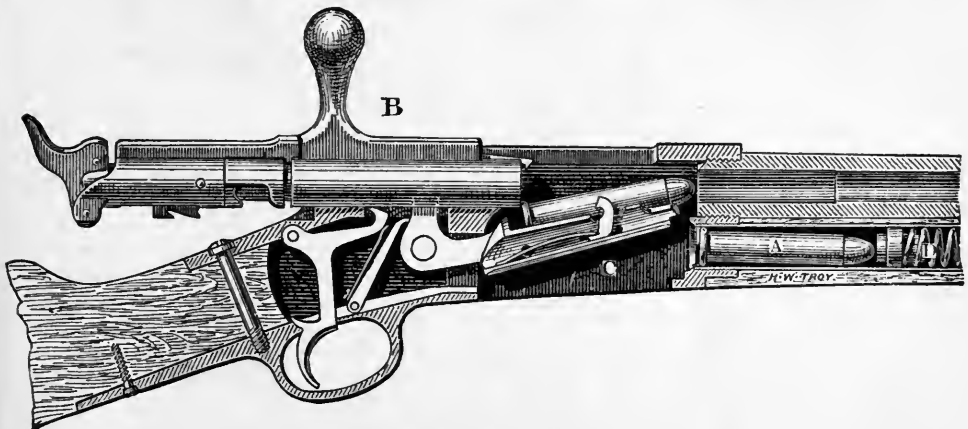

THE KEENE MAGAZINE GUN.

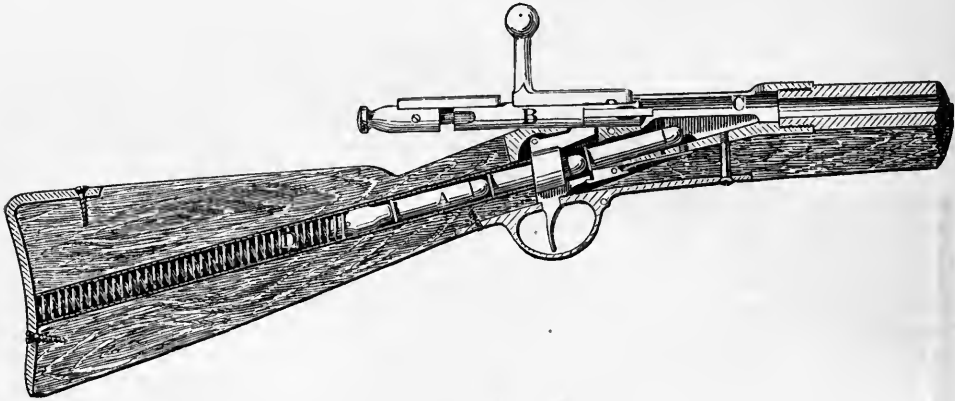

THE HOTCHKISS MAGAZINE GUN.

ment monopoly in the manufacture of arms is a relic of that foreign distrust of an armed population which has had no place here, and was especially guarded against in the adoption of our Federal Constitution. Experience shows that it is through private competition that improvement comes. "Not only," said Napoleon III., "does routine scrupulously preserve, like some sacred deposit, the errors of antiquity, but it actually opposes, might and main, the most legitimate and the most obvious improvements." This has been undoubtedly the experience in the adoption of improvements in arms, and it is to the persistence of inventors rather than to the wisdom of officials that we are indebted for our present position of superiority.

Prussia has shown, in the case of the Krupp manufactory of heavy guns, what can be accomplished by wise fostering of private industry,—distancing England with all her enormous expenditures at the Royal Arsenal of Woolwich, and compelling her at last to call upon her own Armstrong and Whitworth to enable her to maintain her position in competition with the private foundry at Essen. It might easily be shown that for the ideas which have developed the enormous power of heavy ordnance on the other side of the Atlantic, Europe is indebted to the United States. Had

such encouragement been given to our own cannon foundries as was dictated by the imperative requirements of public security, we might have led the world in the manufacture of heavy guns, as much as we have in the fabrication of small arms. Thus would a new industry have been created here, and one not less essential to the public defense than the manufacture of muskets. The only two gun foundries left to us, those at South Boston and West Point, have been suffered to languish, until the manufacture of heavy guns, in which we once promised to excel, is in danger of becoming a lost art among us; and this in face of a need for re-arming our sea-coast defenses, to which attention has again and again been called by the officers of our Engineer corps in the most urgent terms. With vessels afloat carrying fifteen to twenty-four inches of armor, and 100-ton guns, we leave our forts armed with guns less powerful than the 9-inch rifle, weighing 12 tons. In thirty-six hours vessels armed with at least 80-ton rifle-guns could reach New York from Halifax, or San Francisco from Vancouver's Island. Without arguing the question as to the relative importance of torpedoes, forts, and ships in coast defense, it is apparent that what we have of each should be effective of its kind, and not antiquated specimens of some antediluvian period.

A "PERSONAL," AND WHAT CAME OF IT.

"I WONDER why so much money is wasted by people on matrimonial advertisements," said Will Fowler to me one day.

This was apropos of nothing in particular, for not a word had been said for ten minutes; but then he was always popping absurd questions at you.

"I can understand a man's going to the theater," he continued, "or subscribing to a soup-kitchen, or even being fool enough to send a bouquet to some pretty girl, but why on earth he should tumble any more coin into the hungry pockets of these newspaper men is more than I *can* understand. Where does the fun come in? Of course the chaps who advertise haven't an idea of marrying on such an introduction, and equally of course, no woman nowadays is goose enough to answer such an 'ad.'—that is, no woman with whom it would be any pleasure to correspond."

It was a gloomy March day, and Will and I were toasting our feet before the fire in his Chicago office. He was a married man, with a pretty wife and several children, a very clever writer, and possessed of a private income more than equal to his needs; I, a younger class college friend of his, and a pin-feather lawyer with certain heart engagements which precluded all idea of other love affairs. The topic broached by him was argued pro and con, and the result was that I bet him a dinner that a carefully worded matrimonial advertisement would bring in at least fifty answers, the loser to pay for the publication. After long consideration, in which he good-naturedly took part, the following card was written and subsequently published in the Sunday paper most noted for its personals:

HAVING BEEN A WIDOWER FOR TWO YEARS,
I wish to marry again. I am thirty-five years old, five feet ten inches in height, thirty-nine inches around the chest, and have excellent health, mental and physical. Being of a somewhat phlegmatic temperament, I neither ask nor proffer ardent love, but simply desire that there shall be a mutual respect, as my chief reason for marrying is that during my frequent business absences from home my little six-year-old girl may be left in charge of one who will guard her with a mother's care. I am commercial traveler for a large Eastern house, own a suburban cottage, which is comfortably furnished, and have over \$4,000 in U. S. bonds. Perfect respect will be felt for any lady who may answer this advertisement, and absolute secrecy will be observed, whether the application be favorably received or not. Only those need apply who will fairly answer to the following description: Age, between twenty and thirty; education, good; disposition, not given to bickering or fault-finding; health, good, and especially must be free from any pulmonary complaint; appearance, rather pleasant than handsome; reputation that will bear the closest scrutiny. In return for these excellent qualities a modest home and gentle treatment are offered. Address EDWARD CLARKE, Tribune Office.

Monday morning's mail settled the wager, for by that delivery more than the requisite number of letters came to hand. By Monday evening the city correspondence was about exhausted, but for days afterward notes came dropping in from the country districts, the last one coming all the way from Salt Lake City, until the total number received amounted to one hundred and twenty-six. Of these a large moiety had been sent on speculation by women of the lowest class, and were equally disgusting in their perfume, their language, and their purpose. The next largest assortment came from the servant-girl class, and a nice collection of pencil-marks, bad English, and dirt they were. Some had come from sewing-women, telling pitiful stories, many of which bore evidence of their truth in their incoherence. Others, again,—and there were a good many of these—had been sent in joke, as we could easily see, while a half dozen, perhaps, were startling revelations of life and sorrow among educated women, whose want struggled with the feeling of shame. The last-mentioned letters made us feel very uncomfortable and blackguardish, for their genuine grief, mortification, and self-abasement were a rebuke to our thoughtless joke, the only excuse for which was the fact that no such realistic results had been expected. Will, being a good-natured, generous fellow, salved his conscience by giving pecuniary aid in several instances where investigation proved that such aid was needed. One poor girl sent the following plaint:

MR. EDWARD CLARKE.

Dear Sir: If your advertisement is genuine, which I am led to believe from its wording, you are a man who will respect my misfortunes, even if you cannot relieve them. I am not an applicant for marriage, unless it be a necessary ingredient of such service as you may require, for I cannot pretend to a magnetic love for one whom I have never seen and of whom I know nothing. If you prove to be a gentleman, I should dearly like to accept a position as your house-keeper and governess to your little girl, if propriety allow my holding such a place, and will ask in return only shelter and an almost nominal salary that will supply the moderate needs of my wardrobe. Should this be impracticable I will, at all events, be pleased to make your acquaintance, and will promise you respect, if possible, affection. I am the only child of a physician who had, in Philadelphia, a good practice and social position, and, as my mother was not living, I kept house for him until he died, eighteen months ago. Since then mine

has been a sad life. The little property which he left me has all been lost, through my ignorance and the rashness, it may be knavery, of those in whom I depended, and I am now absolutely destitute and almost desperate. Circumstances have thrown me among strangers, and heaven knows what I am to do. I am thirty-two years old, am fairly well educated so far as books go, and am tolerably proficient in music, singing, and drawing; but literary and semi-accomplished knowledge appears to have very little value here. With the useful arts I have a theoretical, but scarcely any practical acquaintance, and cannot, therefore, compete with the thousands in this city who barely support themselves by manual labor. As to my personal appearance, disposition, and character, rather than be my own critic, I leave you to judge from what you may see and hear of me.

Trusting that you are an honest man, and that, if you pay it no other attention, you will at least destroy this letter and remember it only as a thing to be forgotten, I give you my real name and address.

Yours respectfully,
— — —

Careful inquiry proved this to be a case of actual and undeserved hardship, so we returned the letter to Miss—, inclosing with it fifty dollars and the advice that she should not again test the mysteries of the personal column; and six weeks later, through political influence, Will obtained a position for her in the public schools, and I believe she now holds a better place in the same department.

While glancing over the second batch of letters, Will suddenly cried out:

"By George! here's a prize, and a jolly one, too, after this alternate mass of slush and sorrow; just listen to it, will you, and bear in mind it's my booty, as I made the find."

He then read as follows:

MILWAUKEE, WIS. March, 18—

MR. EDWARD CLARKE. ???—I believe you're a real humbug, Ned, and that you're not Ned at all, nor a widower, nor anything else stated in that personal. After carefully studying your little romance, I have made up my mind that you are one of two evils: either a designing wretch of a man who wishes to laugh at and expose the follies of silly womanhood, or else, and that's a great deal worse, a scandal-loving female who would tickle her gossipy palate with the discovered weaknesses of her own sex. If you are the latter, I despise you, for I can't get any fun out of a flirtation with a woman; but if you are the former, I'll excuse your enormities if you'll only make yourself amusing. What you are time may discover; what I am you shall now hear. In the first place,—you men always take that into first consideration,—I'm a decided brunette and better looking than the average woman, at least, so my friends and my glass tell me. I am in my nineteenth year; to be exact, was eighteen last January, and am not the least bit sentimental, but full of mischief as any poor cooped-up girl you ever saw. Now isn't it a shame?—I'm not out of boarding-school yet—and that's the reason you get

this letter; for I'm older than most of the other girls, and feel like doing something that isn't real bad, you know, but that's just a little reckless, and they'll think it's awfully wicked when they find out that I'm corresponding with a man I don't know.

If you are a woman—but I don't think any woman could have published such a thing, so we'll pretend you are not a woman—if you are a man then, and put that piece in the paper just for a *lark*—isn't that an awful word for me to use?—why I will promise to answer your letters so long as they are pleasant and polite; for you must not think I am not a lady because I have written *this* letter. Of course, I have no idea of marrying anybody, and especially not you, for I am rather fond of somebody else and he likes me, at least he sends me boxes of candy and the *sweetest* flowers; but I'm tired of this pokey life and need some sort of a tonic. If you wish you can write to

Yours suspiciously,

JOSIE MASON,
Box—Milwaukee, Wis.

P. S.—This isn't my real name, you see, any more than yours is Edward Clarke; but it is the only name you must know me by. And if by any chance your advertisement should be in earnest, I shall be dreadfully sorry to have written to you in this way, but I'm sure that in that case you'll forgive a harmless joke from a young girl who has scarcely any amusements.

"That girl's a little trump;" said Will, when he had finished reading the letter, "and I'm just the boy to help her drive the blues away. You can have all the rest of the letters, but this one drops to my ink."

It struck me that there might be more fun in this correspondence than in any of the others that offered, so I mildly suggested the impropriety and possible risk of epistolary ventures on the part of a married man. My friend detected the motive, however, and laughingly remarked that a man engaged would run more danger than a man married; so he stuck to his prize, and then and there answered it in a bright and sparkling letter, which overflowed with fun and yet bore marks of prudence and of respect for the young lady. In it he acknowledged the falsity of that personal, and declared that his object was gained in securing so jovial, and probably so pretty a correspondent, vowed that he would write to none of the other damsels who had answered the matrimonial card, and promised, on all the honor an unknown man could possess, that he would make no attempt to discover the identity of "Josie Mason." He took precious good pains, the scamp, not to say anything about his encumbrances, and carefully avoided touching upon his personal affairs.

A voluminous correspondence ensued between these two lunatics, to which I was a

party, in so far that Will always read me the letters from both sides. After some months of this sort of thing had passed, I noticed, and remarked the fact to him, that Josie's style had greatly changed since her first letter; she was less flippant, and evidently strove to appear more womanly. It could also be seen that she regretted her mention of the young man of flowers and candy boxes, for several times she hinted that she had invented that sweet-gifted youth as a convincing argument to the unknown correspondent that she was in search of amusement, not of a husband. Her photograph, sent about this time, showed a very pretty and rather intellectual face, and in return Fowler inclosed the likeness of a good-looking Eastern friend of his. About this time I again urged upon him the propriety of stopping a correspondence which could afford him but little more pleasure, and which might lead to disagreeable results; hinting, at the same time, my belief that the girl was becoming too much interested in him. He treated this advice cavalierly, and spoke in so caustic a manner about the virtue of non-interference that I neither asked to see, nor did he offer to show me, any more of the letters; and although we remained as good friends as ever, that matrimonial card was, by tacit consent, dropped from our list of conversational subjects. My correspondence with three of the unknown fair had ceased long since.

Some six weeks after our "Josie Mason" tiff, Will suddenly said to me:

"It was very considerate of you, old fellow, not to flare up when I got so huffy the other day about your advice in that correspondence matter. The fact is, I was beginning to feel uncomfortable about it myself, and didn't find my temper improve at recalling of your forebodings, which have been flying around me like evil omens ever since I began this affair. It is coming too close home now, however, and I must acknowledge the fear that you are right, and that I have been wrong since the first."

"What's up now?" I asked.

"Well, nothing in particular, but just a sort of feeling that I've been making an ass of myself. I like that little girl first-rate, but, confound it all, she's coming it a wee bit too strong. Not that she has written anything very pointed, you know, but there's a simmering air of spoons and danger about her letters of late. At all events, I'm resolved to pull out of it, so I have written this letter to her on the subject."

"This letter" proved to be a half-and-half sort of epistle, full of regrets for what had been and of regrets for what must no longer be, full of apologies and praises, full of hopes that they might never meet for fear of the possible result, yet hinting at a desire to see her, if only for once. In fact, it was a bundle of incoherent nonsense from beginning to end, the only sensible thing in it being the statement that he returned her letters by that day's mail, and hoped she would do as much with his.

"Well," said I, after reading this precious document, "you have probably shown me this with the idea that I will advise you about it, but all I can say is that it sounds more like a love-letter than any that I have yet seen of yours."

"Yes, I know it does; but what would you have? I can't throw her overboard, like an old handkerchief. If the poor little thing is in love with me, all I can do is to let her down as easily as possible, and to accomplish that I must reciprocate her affection, after a fashion."

Two days later I found Will gloomily pondering over the answer. He did not hand me the letter to read, but said, as he folded it up:

"By Jove! I feel like a thief. Not one word of recrimination, not an expression that is unladylike, and still a mixture of semi-pleading and semi-contempt that makes me feel like a cur. Well, the affair is ended now, thank heaven!"

"So much the better," I replied. "But how about your letters?"

"She says she will send them back after reading them over. By the way, I forgot to inclose her photograph, and she didn't mention it, so I'll keep it as a souvenir."

Saying this, he took the picture from his pocket-book, and after looking at it for a while in a dreamy sort of way, carefully replaced it, and then walked out of the room without a word of parting; but the fag end of a sigh reached me through the closing door.

About a week later Fowler came into my room, saying:

"Here's a nice piece of business. Just read that, will you?"—handing me a letter.

It was this:

MILWAUKEE, September 6th.

SIR: I am a brother of the young lady whom you know as Josie Mason. She has not been well for some time, poor child, and has had to keep her bed during the past week. This morning in finding your correspondence, I also found the cause of her ill spirits. I will not waste time at present in dis-

cussing your blackguardly conduct: that can wait. A few letters, passed between you by way of joke, would have mattered little; but when your words grew warmer in each successive letter, is it strange that an inexperienced child fell into your snare? Now sir, my business is to find who you are for the purpose of getting satisfaction; and if I can't get it in one way, why I am a Southerner, and I'll get it in another. I write this that you may feel uncomfortable while I am looking for you, as you certainly will when I have found you.

ONE WHOM YOU WILL KNOW.

"Phew! This is a nice scrape. What are you going to do about it, Will?"

"What can I do about it except await developments? I really wish it would turn out to be a blackmailing scheme; for then, although I would perhaps feel more like a fool, there'd be less of the knave in it."

"I wouldn't worry about it any more than I could help, old fellow," said I, "for this may be only a first explosion on the part of the brother, which will amount to nothing. It sounds to me like a genuine letter; there's the true ring of indignation in it, and therefore there is the less to be feared. If the parties meant blackmailing it would pay them to employ detectives, but if it is a true bill, why, family pride ought to act as a check upon publicity."

After thinking a bit, Fowler said:

"I'm going to write to him and explain that no harm was intended, and that I am extremely sorry if any harm has come of it. That's the way I feel, and it will do no hurt to send the letter, you know."

"How will it reach him?"

"Hum-m-m, didn't think of that. Yes! I'll send it to her address and write 'for her brother' on it."

The letter was forwarded that evening, and a cleverer bit of composition I have rarely seen. The writer expressed regret for what had happened, and apologized for his share in it; at the same time he delicately insinuated that it would be mortifying to expose a family secret, especially when no benefit could possibly accrue to any member or members of the family most interested. Five or six days later came the following reply:

SIR: Damn your regrets and a fig for your apologies. Those matters should have been thought of earlier in your correspondence with my family. I also decline your advice as to what are the best interests of that family, considering myself fully competent to judge upon that question. My detective thinks he has spotted you, and if you are the man he points out, you are a worse scoundrel than even I had given you credit for being. Is it possible that you have a wife and children, that you are a man of respectable position in the community,

and yet that, merely for the sake of a laugh, you can trifle with the innocent affection of a child, who knows nothing of the world? You will hear again soon from

ONE WHOM YOU WILL KNOW.

"What the deuce shall I do?" asked Will, after I had read this cheerful effusion. "Had I better leave town for a while until it has blown over, if there is going to be a scandal?"

"Certainly not," I advised; "there's no clear proof that he has found you; and even if he has, what can you gain by leaving? The best way to get out of a row is to face the music, and if you do it now it may prove, after all, that there is a bluff game being played. I am partially to blame in this matter, and I will certainly stand by you to the best of my ability."

It was so decided. Fowler bought a revolver and a savage-looking club, and spent most of his time with me; this was the more easily done as our offices adjoined each other, and his family were still absent at a watering place. We did not talk much about the affair, as he evidently shrank from any mention I made of it; but it never left his mind, as could be seen by his inattention to business and his furtive shoulder-watching when he was in the street. At last, after a week of prolonged suspense, the bolt fell.

We were sitting in Fowler's office one day, when the door opened and a voice said:

"This is Mr. Fowler, I believe."

"That is my name," said Will, as his hand slid to his revolver, and he eyed the speaker,—a tall, well-built and rather handsome-looking man, apparently under thirty.

"I should like to speak with you a few moments in private," continued the newcomer, with a bland, ambassadorial air, at the same time giving me a get-out-of-the-room look.

"This gentleman is connected with me," replied Fowler, "and anything you may have to say may be said in his presence."

"I am not here on a business errand, Mr. Fowler, but to speak with you about a purely personal matter. I refer to certain letters which you have lately written. You understand what I mean. Would it not be better under the circumstances to be by ourselves?"

"Whatever question you have to discuss with me, sir," answered Will, "will be none the worse for ventilation before a witness."

"If that is your decision I must of course comply with it. To come to the point then,

sir, I am here to represent my friend George Travers of Milwaukee, who claims that you have grossly insulted him by sending objectionable letters to a member of his family. Do you admit the fact that you wrote those letters? and will you grant Mr. Travers the satisfaction which one gentleman expects from another in such cases?"

"I admit nothing and deny nothing, but if by 'satisfaction' you mean will I give some unknown, or for that matter well-known, man an opportunity to murder me, I shall unquestionably answer, No!"

"Mr. Fowler, my friend and I were officers in the same Confederate regiment, and from long acquaintance with him I can assure you that he is a man of his word. His directions and my inclinations were to treat you as courteously as possible, and only employ positive action if it became positively necessary. Your reply forces that alternative; so I must inform you that he has absolute proof that you are the man whom he has been seeking, that he is determined to treat you as he believes you deserve, and that no evasion or quibble will turn him from his purpose,—which purpose is explained in this letter."

Will blanched a little as he read the document, but he handed it to me and quietly said to the stranger:

"If you'll return in half an hour I will give you an answer, or, if you prefer it, I will send you one through a friend."

The man of war accepted the first offer and retired. The letter read as follows:

SIR: Feeling sure that, although you hold the position of a gentleman, you do not possess the spirit of one, and will not be willing, therefore, to offer the redress naturally expected from one, I send you the following hint in writing, that my friend may be relieved from the disagreeable task of delivering it personally. If you have a spark of manhood you will accept the proposition which he has delivered to you verbally, and I will treat you as though I believed you to be a man of courage; but if you refuse, I solemnly swear that I will horse-whip you in the public streets and brand you as a coward.

(The Man Whom You Know)

GEORGE TRAVERS.

We looked blankly at each other for a few moments, and then Will said:

"Great heavens! This is the devil's own. What am I to do? The fellow seems to be in earnest, and his deputy certainly doesn't look like a blackmailer, and it's a nice pickle, anyhow. If I accept the challenge I'm sure to be disgraced, for of course the whole muddle will get out in the

papers, and by the law in this state I will forfeit all chance of promotion, officially or professionally. If, on the other hand, I refuse to have anything to do with this absurd business, I run the chance of being attacked on the street, in which case, as I have no great physical strength, I shall certainly shoot the man, and either be shot myself or be hauled into court dripping with scandal."

The situation certainly was not encouraging, and I felt quite sorry for Will as he raved along in this incoherent jumble of "ifs" and "ands," until finally I said:

"Brace up, old fellow! This sort of thing wont do. The chief need now is time for consideration; so why don't you put a bold front on the matter and accept his challenge, referring him to me for the arrangements? If there is anything fishy in the business this will stop their little game, and if it prove to be what it seems, a real case, why a compromise may be effected, and if that should fail, you'll be no worse off than you now are, and can fight or decline, as you see fit."

Fowler adopted my suggestion, and when Powder-and-Balls returned, Will said to him, in a quietly fierce manner:

"You will be kind enough to inform Mr. Travers that it will give me great satisfaction to lodge a bullet in his impudent body. My friend, Mr. —, has kindly undertaken the management of the affair, so for further particulars I must refer you to him."

The ambassador looked at me rather curiously, and asked if I would call on him at the Sherman House in an hour. Receiving an affirmative reply, he departed.

I did not find him at the Sherman House, nor did we ever hear again from either him or his principal, nor could we find their names in the Milwaukee directory. It was a decidedly curious affair, and Will puzzled over it immensely, even going so far as to write another letter to "Josie Mason," asking for an explanation; but none came.

A month later I went to Iowa on a long chicken hunt. From the first station I sent back a package by express to Fowler. Among its contents was this letter:

DEAR WILL:

You have played many a severe practical joke on me, for which I have long been your debtor; now I think we can cry quits. Herewith I inclose the entire correspondence between yourself and "Josie Mason" and her fiery brother. Her letters and his were the joint composition of Miss — and

myself, and much trouble it has given us to please your critical literary taste. It was good practice, however, and not such bad fun, so we did not grudge the labor. The challenge was brought by a cousin of hers. Allow me to repeat the advice which you so curtly rejected at the beginning of this little experience, viz. : the impropriety and possible risk of epistolary ventures on the part of a married man.

If you'll take the joke kindly we'll promise not to peach.

Your sincere friend and old chum,

Our handsomest wedding present came from Will. It was a large secretary, beautifully inlaid, and fitted with a gorgeous array of writing material.

HYMN TO THE SEA.

If there is nothing sure but the unsure,
Which is at once its cradle and its grave,
Creative and destructive,—hand that molds,
And feet that trample,—instruments of Change,
Which is itself the instrument of Power :
If these, our bodies, conscious of themselves,
And cognizable by others like themselves,
Waste and supply their forces day by day,
Till there is nothing left of what they were,
The whole man being re-made from head to foot ;
How comes it then, I say, that standing here
Beside the waters of this quiet bay,
Which welter shoreward, roughened by the wind,
Twinkling in sunshine, I am the same man
Who gazed upon them thirty years ago,
Lulled by their placid motion, and the sense
Of something happy they begat in me ?

I saunter by the shore and lose myself
In the blue waters, stretching on, and on,
Beyond the low-lying headland, dark with woods,
And on to the green waste of sea, content
To be alone,—but I am not alone,
For solitude like this is populous,
And its abundant life of sky and sun,—
High-floating clouds, low mists, and wheeling birds,
And waves that ripple shoreward all day long,
Whether the tide is setting in or out,
Forever rippling shoreward, dark and bright,
As lights and shadows and the shifting winds
Pursue each other in their endless play,—
Is more than the companionship of man.

I know our inland landscapes, pleasant fields,
Where lazy cattle browse, and chew the cud ;
The smooth declivities of quiet vales :
The swell of uplands, and the stretch of woods,
Within whose shady places Solitude
Holds her perpetual court. They touch me not,
Or only touch me in my shallowest moods,
And leave no recollection. They are naught.
But thou, O Sea, whose majesty and might
Are mild and beautiful in this still bay,
But terrible in the mid-ocean deeps,
I never see thee but my soul goes out

To thee, and is sustained and comforted ;
 For she discovers in herself, or thee,
 'A stern necessity for stronger life,
 And strength to live it: she surrenders all
 She had, and was, and is possessed of more,
 With more to come—endurance, patience, peace.

I love thee, Ocean, and delight in thee,
 Thy color, motion, vastness,—all the eye
 Takes in from shore, and on the tossing waves ;
 Nothing escapes me, not the least of weeds
 That shrivels and blackens on the barren sand.
 I have been walking on the yellow sands,
 Watching the long, white, ragged fringe of foam
 The waves have washed up on the curves of beach,
 The endless fluctuation of the waves,
 The circuit of the sea-gulls, low, aloft,
 Dipping their wings an instant in the brine,
 And urging their swift flight to distant woods,
 And round and over all the perfect sky,
 Clear, cloudless, luminous in the summer noon.

I have been sitting on the stern, gray rocks,
 That push their way up from the under-world,
 And shoulder the waves aside, and musing there
 The sea of Time has ebbed with me, and I,
 Borne backward with it, have beheld the Past,
 Times, places, generations, all that was
 From the infancy of Earth. The primitive race,
 That skulked in caves, and wore the skin of beasts :
 Shepherds and herdsmen, whose nomadic tents
 Were pitched by river-banks in pasture-lands,
 Where no man was before them ; husbandmen,
 Who shaped out for themselves rude implements
 Of tillage, and for whom the Earth brought forth
 The first of harvests,—happy when the sheaves
 Were gathered in, for robber-bands were near :
 Horsemen with spears, who seized their flocks and herds,
 And led their wives and children captive—all
 (Save those who perished fighting) sold as slaves !
 Rapine and murder triumph. I behold
 The shock of armies in forgotten fields,
 The flight of arrows, and the flash of swords,
 Shields pierced, and helmets cloven, and hosts gone down
 Behind the scythèd chariots : cities girt
 By grim, beleaguering, formidable foes,
 With battering-rams that breach the tottering walls,
 And crush the gaunt defenders ; mailed men
 That ride against each other and are unhorsed
 Where lances shiver and the dreadful sweep
 Of the battle-ax makes havoc : thunderous guns,
 Belching destruction through the sulphurous cloud
 That wraps the league-long lines of infantry ;
 The charge of cavalry on hollow squares—
 Sharp shots, and riderless horses ! This is War,
 And these are men—thy children, Earth ! The Sea
 Has never bred such monsters, though it swarms
 With living things ; they have not overrun

Its spacious realms, and left them solitudes:
 The desolation of the unfooted waves
 Is not of their dark making, but of thine,
 Inhospitable, barren, solemn Sea!

Thou wert before the Continents, before
 The hollow heavens, which like another sea
 Encircles them, and thee; but whence thou wert,
 And when thou wast created, is not known.
 Antiquity was young when thou wast old.
 There is no limit to thy strength, no end
 To thy magnificence. Thou goest forth
 On thy long journeys to remotest lands,
 And comest back unwearied. Tropic isles,
 Thick-set with pillared palms, delay thee not,
 Nor Arctic icebergs hasten thy return.
 Summer and winter are alike to thee,—
 The settled, sullen sorrow of the sky
 Empty of light; the laughter of the sun;
 The comfortable murmur of the wind
 From peaceful countries, and the mad uproar
 That storms let loose upon thee in the night
 Which they create and quicken with sharp, white fire,
 And crash of thunders! Thou art terrible
 In thy tempestuous moods, when the loud winds
 Precipitate their strength against the waves;
 They rave, and grapple, and wrestle, until at last,
 Baffled by their own violence, they fall back,
 And thou art calm again, no vestige left
 Of the commotion, save the long, slow roll
 In summer days on beaches far away.

The heavens look down and see themselves in thee,
 And splendors, seen not elsewhere, that surround
 The rising and the setting of the sun
 Along thy vast and solitary realms.
 The blue dominion of the air is thine,
 And thine the pomps and pageants of the day,—
 The light, the glory, the magnificence,
 The congregated masses of the clouds,
 Islands, and mountains, and long promontories,
 Snow-white, and black, and golden, and purple, and red,
 Floating at unaccessible heights whereto
 Thy fathomless depths are shallow—all are thine.
 And thine the silent, happy, awful night,
 When over thee and thy charmed waves the moon
 Rides high, and when the last of stars is gone,
 And darkness covers all things with its pall—
 Darkness that was before the worlds were made,
 And will be after they are dead. But no,
 There is no death—the thing that we call death
 Is but another, sadder name for life,
 Which is itself an insufficient name,
 Faint recognition of that unknown Life—
 That Power whose shadow is the Universe.

TOPICS OF THE TIME.

British and American Farming.

THERE was a time, not many years ago, when the Englishman who talked political economy for the instruction of the American showed decided hostility to the diversification of American industry. When our protectionists argued for their policy, that it tended to make a nation independent by teaching and helping it to provide for all its own wants, he could not "see the point." The American should stick to his agriculture, he said, and let the Englishman make his clothes for him, because he has unequaled facilities for farming, while the latter has unequaled facilities for manufacturing everything wanted among men. In short, the American should feed the Englishman, and the Englishman should make the cloth and the tools and other commodities for the furnishing of American life.

Well, the policy of protection, right or wrong, has been retained, and owing to that, perhaps, partly, there has been achieved a great diversification of American industry. We spin our own cotton, make our own iron and our own tools, the silk and woolen industries are in a state of rapid development among us, and we could take care of ourselves very comfortably, even if we should be shut off from all the rest of the world. Meantime, our agricultural industries have been pushed forward at so grand and efficient a rate that the Englishman, who wished us to stick entirely to agriculture, finds us at his door with a competition utterly ruinous to himself. We can give him wheat and meat and cheese cheaper than he can produce them, after we have traversed a thousand miles of land and three thousand miles of sea; and so the British agriculturist is embarrassed, and has reached the point where he wishes we were more diversified in our industry and less devoted to agriculture. In short, the British tiller of the soil is in distress. If our readers will turn back to the November number of this magazine, and read Mr. Quinn's short article on "The Agricultural Distress in Great Britain," they will get a very instructive view of the situation, and the relation of American agriculture to it.

Into the midst of this distress comes the English premier. On the 18th of September he made a speech at the annual dinner of the Royal and Central Bucks Agricultural Association, in which he took up the whole question, and treated it after his own manner—a manner singularly wild in its facts and shallow in its philosophy. He evidently wished to impress upon his audience—and his audience was practically Great Britain and the world—that the present distress of the British farmer is not in any way attributable to the system under which he works,—that, on the contrary, that system is a sound and wholesome one. The premier alluded at length to the claim that the agricultural system had broken down because it was obliged to produce three profits—one to the owner of the land, one to the farmer who

hires, stocks and works it, and one to the laborer. His answer to this was that the three profits had to be produced under any circumstances, everywhere, and it seemed to him better that they should be shared between three men than monopolized by one man. In other words, although the land might be owned and worked by one man, still there must be a return for the land, a return for the capital used and the superintendence exercised upon it, and for the labor expended on it. The premier would therefore leave the impression that his countrymen were better off than they would be if the proprietor, farmer, and laborer were all one and the same man!

His allusion to France, in confirmation of his view, seems to us to be singularly and characteristically uncandid and misleading. He asserts that France, which is distinguished in its agriculture by its large number of peasant proprietors, and possesses a country and soil singularly fertile as compared with Great Britain, produces only half as many bushels to the acre as Great Britain. However near the literal truth this statement may be, the premier neglects to state the very pertinent fact, that the small farms, worked by their proprietors, produce the largest yield, while the large farms, of which there are many—owned and worked on the English system—are entirely responsible for the reduction of the average yield to the point at which the premier sees the British advantage. He leaves entirely out of account, also, the fact that the French farmer is less a wheat grower than a producer of other commodities of life. He is a wine grower for the world. He is a silk grower, too, for the world. Indeed, less stress is laid upon wheat-growing in France than in England, because other industries are more profitable. The grapes and the mulberries will buy wheat more easily than it can be grown. But a sufficient answer to Lord Beaconsfield's argument from this illustration is found in the comparative wealth of the agricultural classes of the two countries. The agricultural classes—farmers and laborers—of England are poor. The farmers usually borrow the money they use in farming operations, and the laborers live from hand to mouth. The French farmers are rich and well-to-do persons, as a class. When their government wants a sum of money that would stagger any other government to raise, this class pulls out its old stockings and lends it, so that its securities do not go to a foreign market. This is proof that the premier's illustration is fallacious, and that, somewhere, it utterly breaks down.

Undoubtedly, the last few seasons have been very disastrous to the crops of the British farmer. He has worked at a great—a killing—disadvantage. This will mend. Good seasons will, sometime, come again; but it does strike an outsider that if there were not quite so many men who must make a profit out of what the British laborer wins from

an unwilling soil, that laborer and the man who employs him would stand a better chance of living comfortably. If there were fewer mouths to feed there would naturally be less distress, and two men would apparently live more comfortably on a given sum, if they were not called upon to share it with a third.

But the premier did not stop with France. Alluding to the popular statement that Great Britain cannot compete with America, he says it happens that "at this moment the greatest apprehension is felt in the United States that they cannot compete with Canada." No wonder that this statement was followed by "laughter." Has any American heard of this before? We have read the papers pretty faithfully, but this is the first mention we have noticed of the fact. No, Mr. Premier, that is one of your fabrications. We have too long a start. We are sorry for the British farmer, for we would like to see everybody prosperous; but we suspect it is true that so long as three men have to make profits on the products of the British soil, before they can leave their granaries, we shall be glad to undersell your farmers in their own market, after going 4,000 miles to reach it. As for the competition of Canada, we shall probably be able to stand it, provided your home farmers can. Lord Beaconsfield was trying to comfort the English agriculturist. Now exactly what comfort it can be to him to be told that the Canadian farmer can furnish wheat cheaper than it can be furnished from the United States, when that is so cheap that it is ruinous to his interests, we cannot imagine. "Let us be cheerful," he says, or seems to say, and forthwith paints a picture of gloom spreading over the United States in consequence of the shadow of Canadian competition, when, if he reports the truth, he is simply foretelling the absolute destruction of the home agricultural interest. It will be a sad day for England when Canada can undersell the United States in the British markets!

From Country to City.

It is presumable and probable that there arrives in New York City every day a considerable number of letters from the country, making inquiry concerning what it is possible for a country man to do here in the way of business, and asking advice upon the question of his removal to the city. Every citizen of New York, with country associations, is applied to for information and counsel with regard to such a "change of base," and the matter seems worth the few words a careful and candid observer may have to say about it.

It is well, at the beginning, to look at the reasons which move people to a desire to make the change. The first, perhaps, are pecuniary reasons. A man living in a country town looks about him, and can discover no means for making money in a large way. Everything seems petty. The business of the place is small, and its possibilities of development seem very limited. A few rich men hold everything in their hands, and a young man, with nothing for

capital but his youth and health and hope and ability, feels cramped—feels, in fact, that he has no chance. His savings must be small and slow, and a life-time is necessary to lift him to a point where money will give him power. It seems to him that if he could get into the midst of the great business of the world he could find his chance for a quicker and broader development of wealth; and in this connection, or with this fancy, he writes a letter to his city acquaintance, asking for his advice upon the matter.

Another is smitten by a sense of the dryness and pettiness of the social life he is surrounded by in the country, and the small opportunities he has for personal satisfaction and development. To be able to live among picture-galleries and in the vicinity of great, open libraries; to have the finest theaters and the most attractive concert-halls at one's door; to be where the best minds reveal themselves in pulpit and on platform in public speech; where competent masters stand ready to teach every science and every art; to live among those whose knowledge of the world is a source of constant satisfaction and culture; to be at the very fountain-head of the intellectual, social, and politico-economical influences that sweep over the country; to feel the stimulus of competition and example, and to live in an atmosphere charged with vital activity,—all this seems such a contrast to the pettiness and thinness and insignificance of village life, that the young man, realizing it, sits down and writes to his city friend, inquiring what chance there would be in the city for him. The country seems small to him; the city, large. He feels the gossip that flutters about his ears to be disgusting and degrading; and chafes under the bondage imposed by his neighbors through their surveillance of, and criticism upon, all his actions. He wants more liberty, and for some reasons would really like to be where he is less known and less cared for.

There is still another class of country people who long for a city life, and whose aspirations and dispositions are very much less definite and reasonable than those to whom we have alluded. They are not so particular about business or about wealth, nor do they care definitely about superior social privileges, or about the culture more readily secured in the city than in the country. They are simply gregarious. They like a crowd, even if they have to live in a "mess." They are so fond of living in a multitude that they are willing to sacrifice many comforts to do it. Once in the city, no poverty will induce them to leave it. They have no interest in life outside of the city. These usually get to the city in some way without writing letters of inquiry.

Now, it has probably surprised most inquirers to receive uniformly discouraging answers to their questions. For, indeed, no man knows the trials of city life but those who have left quiet homes in the country and tried it. The great trial that every man from the country experiences on coming to the city, even supposing he has found employment, or gone into business, relates to his home. His thousand dollars a year, which in the country would give

him a snug little house and comfortable provision, would get him in the city only a small room in a boarding-house. The two thousand dollars that would give him something more than a comfortable home in the country, would give him in the city only a better boarding-house. The three thousand that would give him in the country a fair establishment, with horses for his convenience and amusement, would in the city only give him a small "flat" in a crowded apartment-house, and the five thousand in the country that would give him the surroundings of a nabob, would only pay the rent of a house on Fifth Avenue. The country rich man can live splendidly on from five to ten thousand dollars a year, while the city rich man spends from twenty thousand to fifty thousand dollars a year. City incomes look large, but relatively to city expenses they are no larger than the country incomes. The man who lives in the city has experienced the remediless drain upon his purse of the life which he lives, and feels that the risk which a business man runs of coming into unknown circumstances is very great. He feels that unless his country friend knows just how he is going to meet that drain, he will be safer where he is. City life is naturally merciless. It has to take care of itself, and has all it can do to meet its own wants. If a man from the country comes into it, and fails, he must go to the wall. Friends cannot save him. A city looks coolly upon a catastrophe of this kind, for it is an every-day affair, and the victim knows perfectly well that he can neither help himself nor get anybody else to help him. So the city friend, knowing the risks and the needs of city life, dreads to see any country friend undertake them. Then, too, the faithful records of city life show that the chances are largely against financial success in it.

The man of society who is attracted from the country to the city usually fails to calculate his own insignificance when he encounters numbers. The man of social consideration in the country needs only to go to the city to find so many heads above his own that he is counted of no value whatever. "Who is he?" "What is he?" and "What has he done?" are questions that need to be satisfactorily answered before he will be accepted, and even then he will need to become a positive force of some sort in society to maintain his position. City society is full of bright and positive men and women, and the man and woman from the country bring none of their old neighborhood prestige with them to help them through.

To sum up what the city man really feels in regard to the coming of his country acquaintances to the city, it would be not far from this,—viz.:

1st. The chances for wealth are as great, practically, in the country as in the city, and the expenses of living and the risks of disaster much less.

2d. The competitions of city life and the struggles to get hold of business and salaried work are fearful. No man should come to the city unless he knows what he is going to do, or has money enough in his hands to take care of himself until he gets a living position or becomes satisfied that he cannot

get one. Even to-day, with the evidences of renewed prosperity all around us, there are probably ten applications on file for every desirable place, and no man living here could help a friend to a place unless he could create one.

3d. That the social privileges of the city may be greater, while the opportunities of social distinction and the probabilities of social consideration are much less than they are in the country.

4th. That in many respects there is nothing in the city that can compensate for the pure pleasures of country scenery and country life and neighborhood associations.

5th. That a city man's dream of the future, particularly if he ever lived in the country, is always of the country and the soil. He longs to leave the noise and fight all behind him, and go back to his country home to enjoy the money he may have won.

Fiat Money.

THERE is an elderly gentleman in Murfreesboro, Tennessee, who believes in "fiat money." His name is Ewing, and he writes good English for the newspapers, well sprinkled with Latin words and phrases, in the advocacy of his ideas on this strange topic. Moreover, he is a man of feeling, and is wounded and displeased by the contemptuous epithets which we have used in the mention of theorists and doctrinaires of his kind. We take them all back, so far as Mr. Ewing is concerned. We do not believe he is an "idiot," or a "scamp," but, on the contrary, a kind and intelligent gentleman, whose mind is laboring under a condition of obfuscation, induced by an earnest attempt to imitate his creator in the enterprise of making something out of nothing, or its equivalent—stamped paper. We should say, without using any offending epithets, that a man has only to slip into an idea of this kind, to lose his common sense, his power to reason, his ability to judge, and his value as a guide in any matter of finance.

There lies before us a pair of double sleeve-buttons, each formed of two discs held together by a link. The discs are old Roman silver coins, of the class known as "family coins." Exactly under what circumstances these family coins were issued we do not know. Probably Mr. Ewing does, being something of a Latinist. It was doubtless under some provision of law, but let us suppose that they were the offspring of family presumption. Roman coinage was in its infancy, at any rate, and it might well be that men of high position and great power in the state thought it would be nice to have a mint of their own. Let us suppose that one of these ambitious nobles has called his butler to him, at the close of a month of service, and should say: "Here, my boy, are your month's wages." The butler takes the clean silver coins and looks them over. "Why do you examine them so closely?" inquires the master. "They seem to be something new," replies the servant. "They are good," responds the master. "I know they are, for I made them myself." A look of doubt spreads over the servant's

face. "Do you doubt me?" inquires the master. "Do you suppose I would put bad money into your hands?" The butler swallows his doubts, pockets his shining pieces, and retires. He takes a denarius and weighs it with an old one that has been issued by the government, and finds that it balances. Thus convinced that it contains the right amount of silver, he becomes content. The value is there, at any rate. It is worth its weight as silver, and if people will take it in exchange for the commodities he wishes to purchase, it will be good money enough for him. He passes his new money, at last, for eatables and drinkables and wearables, every new taker going through his own questionings, until at last the coin passes from hand to hand without question. It is money, to all intents and purposes. The government does not interfere with its circulation. In point of fact, we believe these family coins were issued from the Roman mint, but we are simply supposing a case. We suppose that their goodness rested on the public faith in the honor of the family issuing the coin. The people took on trust the weight and value of each coin, as stamped silver bullion. The idea that money consisted simply of stamped values, which were to be passed in exchange for other values, was undoubtedly the natural, original idea of money.

Now, suppose our noble began to see that, as he and his neighbors proceeded with their coining, the price of silver began to rise, as Mr. Ewing supposes silver has risen in value in consequence of its use as money in later ages. Suppose he should adopt, or rather, preconceive, such ideas of money as those put forward by Mr. Ewing, and suppose at the end of another month, he should call his butler to him, and handing him a number of stamped pieces of parchment, should say again: "Here, my boy, are your month's wages." The butler takes the pieces of parchment into his hands, and finds stamped upon each of the little squares: "This is a denarius." "But, begging your worship's pardon, this is not a denarius!" exclaims the butler, lugubriously. "Never mind," responds the noble. "I swear it is. There is my ancestor's effigy above the legend, and my name below it, and my family honor is pledged to the statement." "But it is not good for anything. I cannot use it," answers the butler. "Why, sirrah?" inquires the master. "Because it has no value and represents no value," replies the butler, who, it will be observed, has some old-fashioned financial ideas. "Does it not represent my honor, my family, my estate?" inquires the master. "Saving your presence," persists the butler, "I cannot see that your honor or your family has any convertible pecuniary value, or that any square rod

of your estate is distinctly represented by this bit of parchment, or pledged for its redemption." "But this is fiat money," insists the noble master, anticipating Mr. Ewing. "I have said: 'Let there be money,' and there is money, and I give you the first batch." The butler shakes his head, expresses his fears that if it gets to the ears of the police that he is attempting to pass off his master's fiat money, he will be arrested for a cheat, and his master for an insane man, declines to take his pay in such stuff, and retires from the apartment.

We have gone a long distance for an illustration, perhaps unnecessarily, but the sleeve-buttons were here, and seemed to invite the excursion. It seems to us that what, under the circumstances, was illegitimate to the individual is just as illegitimate to any government. The trade of the world consists in the exchange of values. We may sell ten bushels of potatoes for ten yards of cloth. That would be a transaction of trade, but if the man to whom we sell them does not possess the ten yards of cloth which we want, he must give us some other form of value—stamped metal being the usual form, or a paper representative of it. "This is a dollar," printed on a piece of paper, by any person or power whosoever, is a lie, necessarily, in the nature of the case. It is not a sufficient answer to say that nine-tenths of the paper money circulated in the country has no gold or silver behind it, sufficient to answer its demands. It is found that, practically, every paper dollar that asks for redemption is redeemed—that, in fact, there is no paper dollar or promise to pay that cannot on demand be transformed into a gold or silver dollar—that in the practical working of financial matters, there is gold enough to redeem all the promises made by the paper money, and still leave a heavy balance behind uncalled for. It is understood, of course, throughout the financial world, that if all the currency afloat were presented for redemption at one time, the system would break down; but such is the public faith that such a crisis will not arise, and that still all the gold called for will be forthcoming, that paper is preferred to gold, and commands the same price in exchanges. In short, no comparison can be instituted between paper that promises something and paper that promises and represents nothing. Current money must, and always will be a value, or a representative of value. "A horse can climb a tree, in his mind," but no horse ever did climb a tree, and a man can create money out of paper "in his mind," but he cannot pass it, or exchange it for things that have value. Trade, as we have said, is exchange, and that must have value in itself, or in what it represents, which is exchanged for value.

COMMUNICATIONS.

An Objection to English Spelling Reform.

EDITOR OF SCRIBNER.

Sir: In Mr. Lounsbury's article "English Spelling, No. II," I take exception to several of his positions. First, the author takes it for granted that utility is so very much superior to sentiment that the latter deserves no quarter; secondly, he decides that the silent "w" in such words as "wholly," "war-whoop," etc., have never been sounded in authorized pronunciation. I pass by the latter because no data is near enough to be within call. Even Dean Trench comes in for his share of ridicule, because he admits some force in the plea for historic association of ideas. One other point is the condemnation of the letter "k" in "knave," as if "nave" ought to serve every purpose for spelling. It would be rather awkward if the nave of a cathedral were indistinguishable from a living knave; here surely utility would suggest that both forms of the word be used as at present. The gravamen, however, in the present strictures is that neither to literati nor to lay students is any room permitted for sentiment. Eliminate this from culture, or from the study of belles-lettres, and the enthusiasm of the scholar, alike with the interest of the common reader, vanishes. It is like the child asking for bread and receiving a stone. Literature would thus become a soulless machine, a garden without a flower, fruit without taste or beauty. Sentiment under regulation gives scope to the affections; the absence of something to love, would chill ardor, and deprive the world of ideals, without which there can be no solid progress. Utilitarianism is good and proper in commercial concerns, or in certain materials of manufacture, but while mankind have heart and soul, taste and imagination, let there be a healthy play given to all the faculties.

Very truly yours,

N. L.

REPLY FROM MR. LOUNSBURY.

EDITOR OF SCRIBNER.

Sir: Your correspondent has been so carried away by his love of the ideal, that doubtless without intending it, he has put assertions into my mouth that I never made. I said the *w* of *whole* had never been sounded. I did not say so of the *w* of *whoop*, for the very good reason that a *w* appears in it during the period in which orthography represented pronunciation, just as during the same period a *w* does not appear in *whole*. Your correspondent also finds it "rather awkward" to distinguish "the nave of a cathedral" from "a living knave," unless the difference of meaning is denoted by difference of spelling. It would be the mere wantonness of cruelty to add any new disturbing element to the confusion already existing in his mind; for even as things are now, whenever he hears the nave of a cathedral mentioned, how can he tell that the reference is not, after all, to the nave of a wheel?

Nor did I maintain or imply that utility was so much superior to sentiment, that the latter deserved no quarter. My assertion was that the existing orthography rested for its support, not at all upon reason, but entirely upon sentiment—the sentiment of association; a sentiment which, of course, would operate just as powerfully in the case of a reformed orthography, when once established, as it does now in the case of a corrupt one. Not being an advocate of the present spelling, I am not under the necessity of believing that an irrepressible conflict exists between sense and sentiment; nor can I well imagine a much droller delusion than any man's fancying, because he favors a system of orthography, which has nothing in reason to recommend it, that enthusiasm, and taste, and culture, and the ideal, out of pure hostility to reason, will fly to him as their friend and champion.

Very truly yours,

T. R. LOUNSBURY.

HOME AND SOCIETY.

General Principles of Cookery. II. Stewing and Making Soups.

A WITTY Frenchman says: "To make good soup, the pot should scarcely smile." This is as true of stewing meat, as of making soup. To do either well, the whole process must be exceedingly slow, from beginning to end; the saucepan should only "smile."

To make good soup, the meat should be put on in cold water, and slowly brought to the boil, that

the juices may be drawn out. Before it comes to the boiling point, the scum will rise freely; take it off before ebullition has broken and scattered it; then when it does boil, throw in half a cup of water, and skim again—add this water just as it comes to the boil two or three times; it brings all remaining scum rapidly to the surface, and when this rises no longer, set aside to simmer. It must never go below boiling point after this until made. This is the whole secret of clear soup. I will here give Jules Gouffé's receipt for *Pot-au-feu*; if carefully

followed, a clear brown bouillon will be the result, and this bouillon is the foundation of most soups. Boiled down to one-half its bulk it becomes *consommé*.

Pot-au-feu requires four pounds of beef, six quarts of water, eight ounces of carrot, eight ounces of turnip, same quantity of onions, and three ounces of celery and cloves. After once or twice making this soup, the cook will be able to judge by the size of the vegetables the required quantity, but weighing is advisable at first, as much depends on perfect proportion. The meat must slowly simmer for three hours, then add the vegetables, not before; simmer till done. The pot in which bouillon is made should have a very closely fitting lid.

Quick boiling and careless skimming are the causes of cloudy bouillon; supposing, as a matter of course, that all the vegetables have been perfectly cleansed.

While on the subject of soups, I will give an excellent receipt for a white soup, not well known, and very delicious.

To make celery cream soup: boil a small cup of rice in three pints of milk, until it will pass through a sieve. Grate the white part of two heads of celery (three if small) on a bread grater; add this to the rice milk *after* it has been strained; put to it one quart of strong white stock. Let it boil until the celery is perfectly tender; season with salt and cayenne, and serve. If cream is obtainable, substitute one pint of it for the same quantity of milk.

It often happens that soup intended to be brown is not sufficiently so to be inviting without coloring. Caramel is generally used for this purpose; but onions cut in slices and left in a moderate oven until they are black chips (not charred, however), may be kept bottled for this purpose. They are preferable to burnt sugar, as a small quantity added to a stew or soup improves the flavor; or, they may be fried each time (in their own juice without grease) and added with the other vegetables.

For white stock, use veal or fowls instead of beef.

Many a chagrined woman knows what it is to attempt a ragoût from a receipt, and to fail signally, to see the rich creamy fricassée her fancy has painted resolve itself into an insipid mess of broth and curdled eggs. The ideal brown ragoût turns out an unsavory brown fact. In making brown stews, it is advisable to put the meat and onions in a stew-pan without water, cover closely, let them simmer until they are brown and the pan is covered with a rich glaze—be careful not to burn—then add a *little* water and any other vegetables your receipt may direct. Just before serving, skim off carefully all fat; then add a small piece of butter rolled in flour, and let it all simmer again a few minutes.

The above method will make a tough piece of meat tender, and if a dessert-spoonful of vinegar or lemon juice is put in with the meat and onions, the sourness disappears before the meat is done, leaving only the scarcely perceptible dash of acidity, which is the characteristic of most French dishes.

Poultry and game, unless the former is to be fricasseed, are always better thus first stewed without water. It is not, however, an absolute rule; an excellent dish may be made by merely putting meat, water, and seasoning, as directed, in the stew-pan together, if the process is very slow. But who does not remember with a shudder, an island of hare's meat, in a lake of gray flavorless liquid? When meat has been partly cooked in its own steam it will brown without effort on the cook's part, and the flavor will be fine; whether it will be tender depends on the slowness with which it simmers after the water is added.

Boileau declares, emphatically, that "A warmed-over dinner is never good for anything," in which he is entirely wrong. There are some things which, warmed over, are as acceptable as when first cooked; what more delicious than minced veal? (not hashed veal by any means); what more excellent than curried chicken? All curries may be made as well from cold meat. Of course, the general idea of hashed and stewed meat is justified by the wretchedness of it as usually served. Father Prout relates, that when young Thackeray was married and very poor, he asked some one piteously: "Can't you tell my wife how to hash mutton, that it may taste of something besides hot water and onions?" Cold mutton makes an excellent dish, if one will slice half a dozen small onions, or three if large, and put them in a stew-pan, then add a tea-spoonful of vinegar, or juice of half a lemon, lay the meat on them, and cover the stew-pan tightly. In an hour, over a slow fire, the meat will be hot through, the onions brown and tender. Add a piece of butter rolled in flour, a dessert-spoonful of sauce (Worcestershire, walnut catsup, or Harvey) and—for those who like it—just enough curry powder to give an almost imperceptible flavor, say a small tea-spoonful, and an excellent dish is the result.

As receipts for warming-over meats are abundant, I need not quote them here, but only say that the first necessity is to have gravy or soup to warm them in, and to heat the meat *very slowly*. The smallest family may have such gravy always on hand, by carefully saving cold gravy, or soup, and also by making stock of all bones, trimmings, and bits of cold meat, slowly stewing such fragments (bones must be cracked up) for some hours. When rich, strain and set by for use. Carefully remove every suspicion of fat from stews or soup.

CATHERINE OWEN.

Two Kinds of Decoration.

PASSING down Broadway the other day, I was attracted toward a shop window that bore on the sill that much-abused expression, "Decorative Art," and near at hand the word, "Decalcomanie." The connection between decorative art and decalcomanie I could hardly understand, so I stopped and looked in the window for an explanation. If decorated simply means "painted upon," then every thing in that window was decorated. There were plaques

with odalisque heads painted on gold backgrounds; gilded horse-shoes, with pansies twining around the nail-holes; bottles covered with silk, with lilies of the valley and moss-rosebuds reposing on a blue ground; paper-cutters covered with splatter-work; jars covered with decalcomanie, and everything that the ingenuity of man or woman could devise. I never pass that window that there is not an admiring crowd looking in. In Broadway, also, another day, I saw a lady who walked in front of me for several blocks, the crown of whose bonnet was painted with a delicate vine and blossoms! I have seen in houses of people of means and education screens made up of scraps of colored lithographs. A sample of one of these atrocities was on exhibition in the Woman's Pavilion at the Centennial, and won the admiration of crowds. I have known people to take handsome black frames and paint autumn leaves over them—not in a decorative way, but with an attempt to make a close copy of nature. The most monstrous thing in the way of decoration that I ever came across was a fire-place in the house of a well-known artist, not many miles from New York. The fire-place in question was in a sumptuous library, and the tiles—if I may so call them—were of looking-glass, with long grasses and flowers painted on them. I have found that it is often people who spend the most money who display the worst taste. The days of red-worsted cats worked on green-worsted grounds, let us hope, are past. But in the place of these we have worsted imitations of leaves and flowers which, if not quite so bad, ought to be suppressed. So long as the needle-worker confines herself to the suggestive in design, she is likely to make something pretty; but when she attempts to paint a picture with worsted, she will probably fail. There is a branch of needle-work that is an art, but there is very little of such to be seen.

All this decoration, or whatever it may be called, comes from the desire possessed by people to fill a room with their own handiwork. "An ill-favored thing, sir," says Touchstone of Audrey, "but my own." But we hear some one ask: "If you don't want us to decorate frames or work flowers on our table-cloths, how do you expect us to make our rooms beautiful, if our means are limited?" The answer is simple enough: *Get things that are decorative in themselves.* Of these are Japanese, Chinese and India goods. "Yes, but they are expensive." Not necessarily. I can go to the twenty-five-cent counter at Vantine's and pick out any number of really beautiful things. One need only have a little patience and a fair amount of taste to make a very attractive room.

I know a young man near New York who had but twenty-five dollars with which to furnish his room, and he made such a "den" that no one could enter it without envying him. The room was entirely bare when he took possession. The first thing he did was to tear down the common-place marble mantel. Being handy with tools, he built one of white pine, with a high, broad shelf and several smaller shelves, the whole covering the chimney-piece. Then he painted the wood-work black, and the bricks a dark

red. At a junk-shop he bought a pair of andirons for a dollar and fifty cents, and as his hearth was wide he dispensed with a fender. The walls he kalsomined with dark red of the color seen on wood-work in country kitchens. Two pieces of plain olive green wall-paper furnished the dado. Pine strips, turned out at the planing mill and painted black, made the railings. He ran a narrow strip of pine painted like the railing along the wall about a foot from the ceiling, for a curtain rod, and above that he tacked Japanese fans for a frieze. Now for the floor! A carpet was impossible, and he decided to use stain. At the paint shop he bought two pounds of stain for sixty cents, and gave the floor two good coats. But when it was all stained it had a very dull look, so he concluded that he must have a rug—not a \$600 one, but one of modest cost, yet of gay pattern. He came to New York and got a very nice one, four by seven feet, rather coarse, to be sure, but thick and bright, for seven dollars, and it looked very pretty when spread upon the dark floor. For curtains he bought dark-brown canton-flannel at twelve cents a yard. It took two widths for each side of the window. The cross strips he made of old gold canton-flannel, and when the curtains were done, he got rods and rings of pine from the village planing-mill at a cost of one dollar a window, and these he painted black. He also painted the wood-work around the windows black.

The room was now ready for the furniture, but where was that to be found? He waited a little while, and "picked up" just what he wanted at an auction sale store in a back street. For five dollars he got an old-fashioned desk with a row of drawers with brass handles and innumerable pigeon-holes. To be sure it wanted polishing, but he went to work on it with a piece of an old felt hat and some powdered pumice-stone, and after the stains were all taken off he rubbed it with linseed oil. A cabinet-maker would have charged him anywhere from five to fifty dollars for the job: it cost him just thirty cents. For three dollars he bought an old-fashioned mahogany table, which he treated in the same manner. This he set in the middle of the room and covered with wide canton-flannel, the same shade as the curtains, and put a band half a foot wide of the old gold about six inches from the edge. His mother did the necessary stitching by hand, not on a sewing-machine. An old-fashioned looking-glass, which had been given to him by his grandmother, he hung over the mantel-shelf with peacock's feathers stuck all around it. A pair of brass candlesticks from the same source did duty as mantel ornaments, with a pair of Japanese vases that cost twenty-five cents. A few engravings and one or two etchings hung on the walls; one of the former the portrait of Mme. Modjeska, that appeared in SCRIBNER, mounted on a piece of Bristol board; another, Whistler's "White Lady," from the same magazine. The frames were white pine shellacked, and cost with the glass about thirty cents each. Japanese fans were placed on the walls at irregular intervals and made bright bits of color. For fifty cents apiece he bought three battered-up chairs, which he painted

black, all except the rush bottoms, which were painted yellow. The gas fixture in the room was an abomination, but a new one was out of the question. Again Japan came to the rescue, and a rose-colored umbrella was purchased and fastened on to the pipe, handle upwards, so that when the gas was lighted it threw a delicate roseate hue over all who sat beneath. The effect of the room was remarkably prètty, and no one could believe that it had not cost an immense sum to arrange it.

There are so many things that are pretty and decorative in themselves that we cannot but lament that amateurs spend so much time in trying to rival nations and artists of established reputation. A plain red earthen jar is much more artistic, if it is of good form, than the same thing covered with sprawling flowers painted by an inexperienced hand. What is more decorative than a bunch of peacock's feathers, or Florida grass, yellow and fleecy—not those gaudy, unnatural colored grasses to be found in the shops? If you want to put a shell on your mantel do so, but do not gild the inside and paint a landscape on it. Nature has painted shells with the most exquisite colors. A great many people are bothered to know what to do with the fire-place in summer, for there is nothing uglier than a black blower staring you in the face. Twenty-five cents will buy a beautiful Japanese umbrella. Cut the handle off to within a few inches of the top and place the circle of gorgeous color over the square of sheet-iron. I have been in handsome houses where the fire-places were filled with cut tissue paper of different colors, in some cases pinked

along the edges and hung up in front of the grate like an apron! I should as soon think of decorating a black coal-scuttle with decalcomanie. I was in at Vantine's one evening just as the gas was lighted, and noticed that all the lamps were covered with beautiful shades. Closer examination proved them to be of some Japanese material with a very costly look. "I should like one of those shades if they are not very expensive," I said to the salesman. "You can have all you want for ten cents apiece," he replied, and then showed me that they were little umbrellas with the handles and ribs taken out, and the tops cut off to fit over the porcelain shades. I immediately invested to the extent of forty cents. I wanted to get some window-shades the other day, and found that the common brown Holland were the cheapest I could get at the upholsterer's. They cost one dollar and fifty cents a window, and were ugly at that. By accident I heard of the Wakefield rattan shades, and found that they were just what I wanted. They are sold at sixty-eight cents the square yard, and came to one dollar and thirty cents a window, including fixtures. The canton-flannel for curtains now comes in all shades and of all widths and qualities, and costs from twelve cents to one dollar a yard. Jute for this purpose is both cheap and pretty. I know of a lady, who has made a beautiful *portière* of a horse-blanket. It is difficult to understand why a person should go to work and furnish a house in an ugly conventional fashion when it costs just as little to make it unconventional and pretty.

M. L. E.

CULTURE AND PROGRESS.

Arnold's "Light of Asia."*

IF we look back to the time when the heathen Jutes and Saxons had gradually occupied the East and South of England, destroying the warlike among the Britons, or driving them into the West and North, and enslaving the weak and marrying the women, we find examples of the powerful effect made by the Jewish-Greek Scriptures upon minds which, then for the first time, grasped the beauty of the Christian faith. Left over from the ravages of centuries and the neglect of inferior and self-conceited men, we have relics of at least one such example. The great Saxon poet Cædmon sang of the life and death of Christ with a vigor that has not lost its trumpet note in all the years since he first succumbed to the new religion, and turned from lays of war and love to pæans on the meekness of Christ. To compare small with great is to compare Edwin Arnold with Cædmon. Yet the analogy is deep-reaching

and can be pushed far. Cædmon was a barbarian who bowed before the creed of the Roman Empire; Arnold is another who bows before the creed of the Indian Empire. For Indian the Buddhistic creed is, although at times it may have been driven from the land of its origin into countries where its enemies were not strong enough to pursue. As the Germanic-Celtic tribes conquered and plundered Italy before the tenth century, so has a Germanic-Celtic nation conquered and plundered India. As Italy has been revenged by conquests of the mind, so India is being revenged by conquering her conquerors in the spirit. Every year sees more Englishmen beginning to doubt the beauty and utility of their own religious and philosophical ideas, and preparing to accept in their place more or less of the theories elaborated in a greater land. Mr. Edwin Arnold's poem marks the extent to which Anglo-Indians have already changed English thought and English taste. Fifty years ago such a thing as an epic describing the life of the Christ of India would have remained unprinted. Yet a Buddhist now points to the much-admired fragments of Cæd-

* The Light of Asia: or, The Great Renunciation (Mahābhiniṣkramana). Being the Life and Teachings of Gautama. By Edwin Arnold. Boston: Roberts Brothers. 1879.

mon and asks wherein radically lies the difference between the Saxon of the ninth and the Anglo-Saxon of the nineteenth century.

It would be too high praise to call Mr. Arnold a Cædmon outright, for that would be comparing poet with poet. As poetry, "The Light of Asia" cannot be accorded the first rank, notwithstanding the presence of many beautiful passages, and the natural favor with which one turns to novel scenes and novel thoughts expressed in verse. As a workman Mr. Arnold is often slovenly, using a three-syllabled word now as two, now as three syllables, and, unless this be due to the proof-reader, halting every now and then in his rhythm.

The charge which Western Missionaries have brought with the greatest appearance of reason against Buddhism consists in the indifference shown by its priests and votaries to human life. While protecting the lives of a number of beasts, and indeed inculcating horror of shedding the blood of any, Buddhism is charged with being callous to human misery and death by starvation. However true this assertion may be, the life of the Buddha does not confirm it save in this respect, that the Buddha noticed the wretchedness of animals before he realized unhappiness among men. It might possibly result from the scorn of comfort and detestation of the vicissitudes of bodily existence seen in Buddhism. In early youth the Prince Siddhartha, *i. e.*, the Buddha, who, in keeping with the florid taste of Indian literature, was no menial, but the highest of princes who abjured his worldly advantages,—

"would oftimes yield

His half-won race because the laboring steeds
Fetched painful breath; or if his princely mates
Saddened to lose, or if some wistful dream
Swept o'er his thoughts. And ever with the years
Waxed this compassionateness of our Lord,
Even as a great tree grows from two soft leaves
To spread its shade afar; but hardly yet
Knew the young child of sorrow, pain, or tears,
Save as strange names for things not felt by kings,
Nor ever to be felt."

As he grows, his father perceives how his mind is tending, and surrounds him with pleasures, coops him in an enchanting palace, and forbids the people, when he rides out, to allow any sign of death or decay to come in sight. Then he causes him to choose a wife,—Yasódhara, the loveliest of all maidens, fated to be his spouse, and to make his "renunciation of the succession" trebly hard. An interlude tells how the Buddha explained, long afterward, to his disciples how he came to choose Yasódhara; she had been his partner in other lives. The reader will hardly fail to see where Mr. W. W. Story found the idea of the most admired of his shorter poems, *viz.*, "Antony and Cleopatra." The Buddha says:

"I now remember, myriad rains ago,
What time I roamed Himála's hanging woods,
A tiger, with my striped and hungry kind;
I, who am Buddh, crouched in the kusa grass
Gazing with green, blinked eyes upon the herbs
Which pastured near and nearer to their death
Round my day-lair; or underneath the stars
I roamed for prey, savage, insatiable,
Sniffing the paths for track of man and deer.
Amid the beasts that were my fellows then,
Met in deep jungle or by reedy jheel,

A tigress, comeliest of the forest set,
The males at war; her hide was lit with gold,
Black-brodered like the veil Yasódhara
Wore for me; hot the strife waxed in that wood
With tooth and claw, while underneath a neem
The fair beast watched us bleed, thus fiercely wooed.
And I remember, at the end she came
Snarling past this and that torn forest-lord
Which I had conquered, and with fawning jaws
Licked my quick-heaving flank, and with me went
Into the wild with proud steps, amorously.
The wheel of birth and death turns low and high."

Mr. Arnold has brought from India pictures of the bazaar, of rustic life, and of large landscape. Toward the end, the poem suffers from having too great variety of complexion. For as the Buddha became a teacher toward the end of his life, so the poem follows him into didactics. The eighth book contains a poetic digest of his doctrine of Nirvana, expressed in four-line stanzas, necessarily more abstruse than the earlier parts of the work. But while these suffer from relationship with simpler chapters, they are in themselves full of grandeur and beauty, albeit too much spun out and insufficiently organized. No part of this fine poem surpasses this:

"Before beginning, and without an end,
As space eternal, and as surety sure,
Is fixed a Power divine which moves to good,
Only its laws endure.

"This is its touch upon the blossomed rose,
The fashion of its hand shaped lotus-leaves;
In dark soil and the silence of the seeds
The robe of Spring it weaves:

"That is its painting on the glorious clouds,
And these its emeralds on the peacock's train.
It hath its stations in the stars; its slaves
In lightning, wind, and rain.

"Out of the dark it wrought the heart of man,
Out of dull shells the pheasant's penciled neck;
Ever at toil, it brings to loveliness
All ancient wrath and wreck.

"The gray eggs in the golden sun-bird's nest
Its treasures are, the bees' six-sided cell
Its honey-pot; the ant wots of its ways,
The white doves know them well.

"It spreadeth forth for flight the eagle's wings
What time she beareth home her prey; it sends
The she-wolf to her cubs; for unloved things
It findeth food and friends.

"It is not marred nor stayed in any use,
All liketh it; the sweet white milk it brings
To mothers' breasts; it brings the white drops, too,
Wherewith the young snake stings."

In strict accordance with the faith which "The Light of Asia" sets forth, the poem leaves one depressed. Few people can rejoice to see their hope of heaven set so far away from them that it becomes a question of abstract theory whether the soul is to merge itself into the divinity, or to be actually "blown out like a candle," as Mr. Max Müller fancies the idea is which lies at the root of the word Nirvana. Western people are fuller of youth, life, and hope than Orientals, and do not want to believe in such remorseless theories of the universe. But Eastern minds are imbued with the uselessness of fighting against fate, and therefore turn with delight to the Buddha, who tells them that happiness can only be reached by destroying the capacity for emotion. Suicide, even on so grand and elaborate a scale, is

not in accordance with the temperament of the majority of Western thinkers, nor, in fact, is it accepted always in the East. The Orient has always had bitter partisans for and against different shades of opinion regarding the main tenet of Buddhism. The variety of religious beliefs in the East is so great that no man has yet been able to classify them even roughly. The science of religion, inaugurated by Burnouf, has only begun its task.

The proof-reader has been in trouble with the Sanskrit words, of which there is a plentiful sprinkling. The use of words not readily understood is always regrettable in poetry; but under the circumstances it was hardly to be avoided by Mr. Arnold. For the benefit of readers of "The Light of Asia," we subjoin a rough vocabulary, in place of the careful list which the poet's English publishers might have supplied.

VOCABULARY.

Aham, I. Angana, "a woman." Asita, the "black." Arati, wrath. Asva-ratna, "jewel of a horse." Avidya, ignorance. Bhagavat, Lofty One. Bhût, an evil demon. Buddh, the wise. Brahman, priest. Chitra, the "variegated" one. Chakra-ratna, "jewel of a wheel." Chakra-varin, "wheel-turner," or emperor of the world. Devadatta, "god-given," Theodore. Devas, male angels. Devis, female angels. Devaraj, "king of angels." Dharma, law. Dhyana, "meditation." Dukha, "sorrow." Gunga, Ganges. Guru, teacher. Hasti-ratna, "jewel of an elephant." Karma, action. Kshatriya, warrior. Istri-ratna, "jewel of a woman." Loka, the world. Mahâbhinishkramana, "great renunciation of succession." Mahâprajâpati, "great father of peoples." Mano, mind. Mudra, joy. Nagas, snakes. Nirvana, complete extinction, or return of the soul to the god-head. Nasyami, I am lost. Nasyati, it is lost. Om, exclamation of devotion, sacred word. Rajagriha, "king's house." Raga, "passion." Ramma, "pleasant." Satya, truth. Sâkyas, the "self-potential," a line of kings. Sari, a veil. Suramma, "very pleasant." Subha, "beautiful." Smriti, "remembered." Srutî, "heard." Sujâta, "well-born." Swerga, "heaven." Silabbat-paramâsa, "most amiable." Skandha, the five elements of bodily existence. Shrofi, a money-changer. Sudra, laborer. Trishna, thirst. Tathagato, "Right Path." Vahuka, a famous charioteer.

"The Letters of Charles Dickens."*

IF the late John Forster was, as many think, a skillful biographer, his skill deserted him when he sat down to write his Life of Dickens. It is a disagreeable book, in that it destroys respect for its subject, and a disappointing book, in that it excludes all knowledge of him other than that possessed by Forster himself. He sought to monopolize Dickens, as much as Boswell sought to monopolize Johnson, and succeeded in doing so as far as his own book is concerned, for it contains nothing but Dickens and Forster, and considerably more Forster than Dickens. That Dickens had other friends and other correspondents never entered into his biographical calculation; neither did he admit the possibility of his misunderstanding so complex and contradictory a nature. His book satisfied him, we suppose, from the vein of arrogant complacency which runs through it, but it satisfied no one else, for the least sympathetic reader could not but feel an irreconcilable difference between the man as he portrayed him, and his work as the world knows it. This cannot be Dickens, we said to ourselves—

* The Letters of Charles Dickens. Edited by his sister-in-law, and his eldest daughter. In Two Volumes. New York: Charles Scribner's Sons.

certainly not Dickens as he appeared to his friends. We have heard what Forster has to say; we will wait now and hear what they have to say. They have not spoken yet, after his voluminous fashion, but they have given us reminiscences of Dickens from time to time, and have led us to distrust the judgment of Forster. We have revised it altogether, since we have read these Letters, which reveal the personality of their writer as we find it in his books, and show him to have been a bright-minded, warm-hearted gentleman; a cheery, affectionate friend, and a tender, loving husband and father. We accept their testimony because it is unconsciously given, and because it is consistent with itself. It is a trying ordeal to the memory of any writer to have his private correspondence printed as fully as it is here; but it is an ordeal through which the memory of Dickens has passed triumphantly. We know him now more intimately than ever before, and are glad of the knowledge that we have obtained, for it is honorable alike to his head and his heart.

No English writer of the century—with the exception, perhaps, of Scott—ever earned so much by his pen as Dickens. Remembering this fact, the first reference in his letters to the sum offered for the then unwritten "Pickwick Papers" is of striking significance. It occurs in a letter to Miss Catherine Hogarth, the lady to whom the young writer was soon to be married, and was written in 1835, from his rooms in Furnival's Inn.

"They (Chapman and Hall) have made me an offer of fourteen pounds a month to write and edit a new publication they contemplate, entirely by myself, to be published monthly, each number to contain four wood-cuts. I am to make my estimate and calculation, and to give them a decisive answer on Friday morning. The work will be no joke, but the emolument is too tempting to resist."

The next letter to the same correspondent shows us the writer at work:

"I have at this moment got Pickwick and his friends on the Rochester coach, and they are going on swimmingly, in company with a different character from any I have yet described, who, I flatter myself will make a decided hit. I want to get them from the ball to the inn before I go to bed, and I think it will take me until one or two o'clock, at the earliest. The publishers will be here in the morning, so you will readily suppose I have no alternative but to stick at my desk."

The character who was to make a decided hit was Jingle. "Pickwick" finished and "Nickleby" begun, Dickens made an expedition with Mr. Hablot K. Browne ("Phiz") to investigate the condition of the Yorkshire schools. There came into the inn, where they stopped on the way, an old lady, who turned out to be the mistress of one of those schools, returning from her holiday stay in London.

"She was a very queer old lady, and showed us a long letter she was carrying to one of the boys from his father, containing a severe lecture (enforced and aided by many texts of Scripture) on his refusing to eat boiled meat. She was very communicative, drank a great deal of brandy and water, and towards evening became insensible, in which state we left her."

One of the most humorous letters that Dickens ever wrote was an answer to a little boy who had written to him as "Nicholas Nickleby" was approaching completion, stating his views and wishes as to the rewards and punishments to be bestowed upon the

various characters in the book. Dickens addresses him as "Respected Sir," and says that he has given Squeers one cut on the neck and two on the head, at which he appeared much surprised and began to cry, which being a cowardly thing, was just what he should have expected from him.

"Nicholas had his roast lamb, as you said he was to, but he could not eat it all, and says if you do not mind his doing so he should like to have the rest hashed to-morrow with some greens, which he is very fond of, and so am I. He says he did not like to have his porter hot, for he thought it spoilt the flavor; so I let him have it cold. You should have seen him drink it. I thought he never would have left off. I also gave him three pounds of money, all in sixpences, to make it seem more, and he said directly that he should give more than half to his mamma and sister, and divide the rest with poor Smike. And I say he is a good fellow for saying so; and if anybody says he isn't I am ready to fight him whenever they like—there!"

He promises to attend to Fanny Squeers, who is like the drawing which he has sent of her, except that the hair is not curly enough. She is a nasty, disagreeable thing, and it will make her cross when she sees it.

"I meant to have written you a long letter, but I cannot write very fast when I like the person I am writing to, because it makes me think about them, and I like you, and so I tell you. Besides, it is just eight o'clock at night, and I always go to bed at eight o'clock, except when it is my birthday, and then I sit up to supper."

A favorite correspondent of Dickens was Macready, whom he always regarded with great intellectual respect. He appears at his best in his letters to him, and never more humorously than in one which he wrote him after his retirement from the stage, and which somehow reminds us of the whimsical epistles of Charles Lamb. The gravity of the advice which he gives him as to what he should do when he comes up to London, is laughable enough.

"You must be very careful, when you come to town to attend to your parliamentary duties, never to ask your way of people in the streets. They will misdirect you for what the vulgar call a 'lark,' meaning, in this connection, a jest at your expense. Always go into some respectable shop, or apply to a policeman. You will know him by his being dressed in blue, with very dull silver buttons, and by the top of his hat being made of sticking-plaster. You may perhaps see in some odd place an intelligent-looking man with a curious little wooden table before him, and three thimbles on it. He will want you to bet, but don't do it. He really desires to cheat you. And don't buy at auctions, where the best plated goods are being knocked down for next to nothing. These, too, are delusions. If you wish to go to the play to see real good acting (though a little more subdued than perfect tragedy should be), I would recommend you to see — at the Theatre Royal, Drury Lane. Anybody will show it to you. It is near the Strand, and you may know it by seeing no company whatever at any of the doors. Cab fares are eight-pence a mile. A mile, London measure, is half a Dorsetshire mile, recollect. Porter is two-pence per pint: what is called stout is four-pence. The Zoological Gardens are in the Regent's Park, and the price of admission is one shilling. Of the streets, I would recommend you to see Regent street and the Quadrant, Bond street, Piccadilly, Oxford street, and Cheapside. I think these will please you after a time, though the tumult and bustle will at first bewilder you."

Dickens was very fond of the theater, as one might have inferred from the melodramatic situations in some of his stories, and was never more delighted than when strutting his little hour before the foot-lights. He might have earned his living behind the scenes, if everything else had failed with him, for he was fertile in stage resources. "Ah, sir," said a master carpenter of one of the theaters, "it's a universal observation in the profession, sir,

that it was a great loss to the public when you took to writing books."

There are passages in these delightful letters,—picturesque bits of description, sparkling scintillations of wit and humor, curious and felicitous terms of expression, etc.,—which are equal to anything that Dickens ever wrote. They extend over a period of thirty-five years, the last two being dated the day before his death, and are addressed to many of the most noted of his contemporaries—authors, artists, actors, and the like, whom he admired with a singleness not common, we fear, among men of letters.

Admirable as compositions, as if from the first he had foreseen that the day would come when they would be collected, they give us an insight into his daily life not elsewhere to be obtained, and clearly portray the manner of man that he was,—a hard worker at his desk when his books were in progress; a charming companion when he was traveling, as he loved to do; an admiring and hearty friend, full of sympathy and kindness; and at all times a careful, active man of business, doing whatever his hand found to do with all his might, whether it was superintending amateur theatricals or editing his periodicals. More *private* letters, in the strictest sense of the word, were never before made public. They are frank, manly, and affectionate; and though communicative, as such letters should be, are not in the least egotistical. They authenticate themselves, in short, as unconscious revelations of the fine disposition, the hearty nature, and the beautiful genius of Charles Dickens.

Taylor's "Studies in German Literature."*

THESE twelve lectures by the late Bayard Taylor, delivered originally before the students of Cornell University, are not a mere compilation of fragmentary information and judgments concerning the principal authors and epochs of German literature. They are rather a series of independent studies, remarkably complete within their narrow compass, abounding in happy illustrations and affording us many a pleasant glimpse of the author's genial personality. Although Mr. Taylor's natural attitude was one of deep sympathy toward Germany and the products of her intellectual life, he assumes in these lectures a distinctly Anglo-Saxon point of view. He nowhere echoes the extravagant and uncritical praise of mediocre writers, which is so deplorably prevalent among the literary historians of the Fatherland, while on the other hand he accords the heartiest recognition to all that is genuine and enduring.

The first lecture sketches in a clear and comprehensive manner the earliest beginnings of German literature, summarizes briefly what we know concerning the ancient Goths, and gives specimen translations from the *Heliand* and *Ofried von Weisenburg's Harmony of the Gospels*. In regard to the Gothic bishop, *Ulflas*, the translator of the

* *Studies in German Literature*. By Bayard Taylor. With an Introduction by George H. Boker. New York: G. P. Putnam's Sons. 1879.

Bible, we think Mr. Taylor makes a misleading statement when he says that tradition credits him with having invented an alphabet of his own. Such a tradition undoubtedly exists, but modern scholarship has long ago proved it to be erroneous, and it is very easy, at the present day, to trace the Gothic letters to their sources. What Ulfilas did (and, it must be admitted, with admirable judgment and skill) was to adapt, and perhaps, in some instances, slightly modify, the ancient Gothic or Scandinavian runes, and, where these did not suffice, to supplement the missing sounds from the Greek alphabet. The translations from the Song of Hildebrand preserve to a remarkable degree the rough vigor and directness of the original, and are, moreover, entirely free from those mannerisms and archaisms to which less skillful translators are apt to resort when they wish to produce similar effects. The selections from the *Heliand*, however, as well as all the other translations which are scattered through the book, except those from "Faust," aim rather at literalness than at the exact preservation of the poetic tone and color. One must bear in mind that they were very hastily made, to be read before an audience of college students, and Bayard Taylor would probably have re-written many passages and polished and refined others, had he lived to prepare his work for publication. For all that there is a great charm in the simplicity and spontaneous flow of these verses, and they are perhaps the more valuable to the student for the very fact that they avoid elaborate paraphrases and circumlocutions.

The second lecture, entitled "The Minnesingers," deals chiefly with the lives and writings of the three representative poets, Walther von der Vogelweide, Conrad von Würzburg, and Ulrich von Lichtenstein. Although recognizing fully the excellencies of this chapter—particularly the power of condensed narration which is everywhere displayed, and the admirable characterization of the Minnesinger period in its totality—we are disposed to question some of the conclusions at which the author has arrived regarding the three principal singers. Mr. Taylor is undoubtedly right in regarding Walther von der Vogelweide as the most vital personality and the most genuine poet of the three, but while he utterly condemns the picturesque folly of Ulrich von Lichtenstein and the Quixotic spirit which everywhere breaks forth in his life and in his song, he forgets to mention that Walther von der Vogelweide, too, displayed erratic tendencies in his youth, and wrote songs which, from a moral point of view, were no less reprehensible than those of the author of "Frauendienst." Moreover, some of the minor poems of Ulrich, and especially his *Minnelays*, seem to us to show a very sensitive ear for melody and a considerable amount of talent. We notice that Mr. Taylor in this chapter translates the German word *Mittelhochdeutsch* with "Mediæval High German" instead of "Middle High German," which, among philologists, is the accepted term.

Our space does not allow us to analyze in detail each one of the succeeding lectures. They all present in a very attractive form the easily accessible

facts concerning the subjects with which they profess to deal. The author does not concern himself much with criticism, but with plain and direct narration. His purpose is to teach, and he accomplishes this, not in the old pedantic style, by a dry presentation of barren details, but by evolving each literary phenomenon from the age and the soil from which it sprang, and further familiarizing it to his audience by continual illustrations and comparisons, drawn from the wide realm of knowledge which was at his command. Thus in speaking of the Mediæval German epics, *Parzival*, *Erek* and *Titarel*, he draws the most significant parallels between these and the Tennysonian version of the Arthurian legends. The meter of the *Nibelungenlied* becomes very intelligible to us, when by a trifling modification it is identified with that of Macaulay's "Lays of Ancient Rome"; and the absurdity of the jingling rhymes of the later Minnesingers is brought home to us in a forcible manner, by the happy quotation from Tom Hood's "rhymed blank verse."

In reading the latter portion of this book, we have been singularly impressed with the catholicity of judgment which enables the author to form such a favorable opinion of the versatile and prosperous trifler, *Wieland*, and at the same time do full justice to the earnest simplicity, combativeness, and religious ardor of Luther, and the artistic conscientiousness of Goethe and Schiller. We cannot point to a single instance in which Mr. Taylor has failed to grasp the key-note of a great man's character, and fairly to present his claims to greatness; but we are inclined to believe, that in the case of *Wieland*, he has attached too much significance to Goethe's eulogistic utterances concerning his recently deceased friend, and allowed the halo which surrounded the amiable old epicurean during his lifetime to dazzle him and make him blind to the shallowness, the inconsistency, and the general perfunctoriness which characterize his writings.

The lecture on "Faust" sketches rapidly the plot of the poem, and traces in comprehensive outlines the vast structure of thought, which underlies and upholds this monumental creation. The intimate connection between the First and the Second parts is duly insisted upon, the interpretation of the bewildering allegories hinted at, and the organic coherence of the whole work strongly emphasized.

We know of no other work in the English language, which furnishes within the same limit, such an amount of accurate and valuable information concerning the principal epochs of German literature.

Farrar's "Life of St. Paul."*

THE reputation of Cannon Farrar's excellent "Life of Christ," has made it sure that this new work will receive a wide welcome and command profound respect. Here are the same attractive

* The Life and Work of St. Paul. By F. W. Farrar, D. D., F. R. S. 2 vols. 8vo. 678, 668 pp. Uniform with "Life of Christ." New York: E. P. Dutton & Co.

brightness of composition, the same enthusiastic love of the subject, the same affluent learning from limitless sources. Brilliancy of epithet and picturesquequeness of artistic pose, make up for occasional floridness of description, and frequent wild play of imagination. In a few of the delineations of feeling ascribed to the apostle, there is so much indulgence in speculative analysis of the motives and purposes, which the author thinks Paul had, or must have had, that a playful scholar would be tempted to ask: "How is it that thou hast found it so quickly, my son?"

On the question of Paul's marriage, this author reaches a satisfied state of mind at once: he thinks the apostle formerly had a wife, and had a "right to lead one about" as well as Peter; but the woman was undoubtedly dead before he became a Christian. He rests for his proof of this upon the "vote" Saul cast for Stephen's condemnation; this argues him to have been a member of the Sanhedrin, which was impossible except for one who was the father of children, and knew how to rule them well. They must have died, too.

There are those who will be disappointed to find that Canon Farrar insists on dropping the Eunuch's profession of faith out of the eighth chapter of the Acts as spurious; but perhaps they will be comforted to discover how sharply he tells some other people that it is high time they stopped calling a "meeting of the church in Jerusalem," by the stately name of the first ecclesiastical "Council." Others will be troubled to know now who the "Man of Sin" is; for this writer distinctly declares it cannot be the pope of Rome. He reminds all that wretched discussion to the "vast limbo of exploded exegesis,"—wherever that may be—and says he knows nothing about it. With a like worry of mind over the famous quarrel with Barnabas, he withdraws from the decision concerning its merits; but he says quaintly enough that he supposes "each was partly right and partly wrong."

The account of Paul's speech at Athens is really fresh and novel. The author gives us to understand that this was a piece of popular ridicule of the apostle from beginning to end. Just for fun, the mob invited an address on the grand stand of their nation, to see what so insignificant a speaker—this "ugly little Jew"—would do if a chance were offered. They laughed at him and went their way, and Paul was more disgusted than ever he was before or after.

When we reach the latter part of the second volume, where an investigation of the Epistles is expected, we find a very singular form of paraphrase adopted instead of a translation. The author assumes to state, often in his own words alongside the authorized text, what Paul was trying to teach. Sometimes this has a rare felicity; but one feels as if it ought not to be trusted. It is a perilous way of interpretation for any expositor to adopt in such a case; and many will be ready to believe that Canon Farrar has not had much better success than other people. Some will really be grieved that this great book, so welcome and so excellent at many

points, must be marred by an evident attempt to engraft upon the language of the apostle Paul in the epistle to the Romans the peculiar views for which this author has been brought into question.

A little vexation will come to a commonplace few, who have old associations that they supposed were worth cherishing, when they have to grapple with some extraordinary forms of expression, and even of spelling, which they meet everywhere on the pages of this biography. There may be a need of such words in our English tongue as "glossolaly," "otiose," "cult," and "gynaecium;" but one wonders why in a popular work, it is necessary to metamorphose queen Candace into "the Kandake of Meroe," or to alter Cephas into "Kephas," and call Cappadocia, Cilicia, and Crete, "the three most villainous k's of antiquity, Kappadokia, Kilia, and Krete." But this may be what we shall have to come to after all.

Most readers will close these beautiful volumes with regret. The best thing about them is, that while they leave one admiring the writer for his literary work, they still leave him loving the Great Apostle, whose wonderful life they commemorate. Finest of many fine scenes is the last. Brief, graphic, picturesque, with just a few master-strokes of the pen, the spectacle of the martyrdom is set before us. And the motto is worthy of the scene: "God buries his workmen, but carries on their work."

Bret Harte's "Twins of Table Mountain."*

A NEW collection is sure to rouse the same pleasure over those stories which do Bret Harte justice, and the same regret over those that fall below the standard he has made for himself. The five tales in the present volume contain no one quite so good and no one quite so poor as certain of his earlier contributions to the monthly press. The latest development of his style is found in "A Legend of Sammtstadt," since it is inspired by a residence in Germany, where he has been occupying a consular position for the United States. It sounds like a lazy production, and moreover, although eminently readable, is not especially original. We catch a distinctly Hawthornean flavor, for example in this passage, where Mr. James Clinch of Chicago is about to make the visionary acquaintance of mediæval German ancestors, the Kölnsche of Köln:

"He looked up in her eyes. There was permission: there was something more, that was flattering to his vanity. He took the wineglass, and, slowly and in silence, filled it from the mysterious flask.

"The wine fell into the glass clearly, transparently, heavily, but still and cold as death. There was no sparkle, no cheap ebullition, no evanescent bubble. Yet it was so clear, that, but for a faint amber-tinting, the glass seemed empty. There was no aroma, no ethereal diffusion from its equable surface. Perhaps it was fancy, perhaps it was from nervous excitement; but a slight chill seemed to radiate from the still goblet, and bring down the temperature of the terrace. Mr. Clinch and his companion both insensibly shivered."

After this Mr. Harte works out one of those disappointments to which he is prone; not that it is

* The Twins of Table Mountain, and Other Stories. By Bret Harte. Boston: Houghton, Osgood & Co.

disappointing to find that Mr. James Clinch has been dreaming, but that the result does not pay for the elaborate machinery. He does not preserve the Hawthornean "atmosphere," but only for a time assumes the Hawthornean tone. The contrasts between Germany and America are made with a harsh pencil and neither country is spared. "Views from a German Spion" (a *Spion*, or spy, is a mirror outside a window in which the passers-by are reflected) gives a vivid glimpse of outside German life in a small Rhenish town. Mr. Harte is unfortunate in seeing Germany after the strain of a great war and the huge growth of militarism, and since the necessity of acting up to their reputation has taken from the poor Germans what quiet jollity they formerly possessed.

On his old ground Mr. Harte is at times quite as strong as ever. Who else can give the startling contrasts of Western life so resolutely, so pitilessly? and who can work so well the pathetic and noble vein, at the same time, in the ignoble block? "An Heiress of Red Dog" brings in our old friend Jack Hamlin. "The Great Deadwood Mystery" is clever in its Western folk, but too broad a caricature in its Bostonians. Boston Philistinism is too admirable a joke to be treated so cavalierly as this. Mr. Harte loses his temper over it, and becomes less effective than Mr. Howells, who always touches it delicately and with self-possession. The scene between Mrs. Rightbody and the two members of the Vigilance Committee is one of the author's best. It is noticeable that a coarse passage in the second part cannot be found in the story as first published in this magazine. But in "The Twins of Table Mountain," Mr. Harte strikes again the full note of his genius. Whether it be plot, characterization, or description of Western landscape, each part is admirable. This story alone would be enough to make a reputation: the author is entirely himself; there is no trace of Dickens, Hawthorne, or any other writer; it is marred by no strained, foreign, or hackneyed words; the scene is novel, the humor fine, the pathos exquisite; short story though it be, it is an honor to American literature.

Miss Phelps's "Sealed Orders."*

MISS PHELPS is best when she describes the common country life or nautical characters of New England. High life is for her a pitfall. As soon as she attempts to describe persons of ease and wealth her descriptions become fantastic, her characters unnatural. But when she recounts the adventures of a woman preacher among the hard-worked, pinched inhabitants of a sterile township of New Hampshire or Massachusetts, as in "A Woman's Pulpit," excellent insight into local habits and character is the result. These seventeen stories and papers contributed to the magazines and other periodicals, show keen powers of observa-

tion and a good deal of force as a story-teller, without very great art.

"An Earnest Trifler."*

ON the principle that imitation is the sincerest flattery, Mr. Henry James, Jr., ought to feel complimented if he reads "An Earnest Trifler." "Nathan Halstead" is the "earnest trifler," and he is an extension and somewhat of a dilution of "Felix" in "The Europeans." The anonymous author is not without skill in writing, whatever may be her lack in constructiveness. The character of Halstead is certainly true to life, in a general way: young men like him exist; they interest themselves strongly in a number of women without really loving any. It is a type by no means rare, and more likely to interest young ladies than the world at large. "An Earnest Trifler" may be commended to young women between the ages of fifteen and twenty-five as a novel, pleasant to read, which is more instructive than moving.

Guernsey's "Thomas Carlyle."†

THIS is among the most interesting and the most useful of the series in which it worthily fills its place. It is a volume of two hundred pages in which the literary career of the great Scotch humorist is narrated and exemplified with the aid of perhaps a hundred pages of quotations from his own writings. Mr. Guernsey has done an excellent piece of journeyman literary work; he gives us no brilliant and unforgettable sentences—like the "Mr. Carlyle is for calling down fire from heaven whenever he cannot readily lay his hand on the match box"—such as abound in Mr. Lowell's essay; but he does give us a straightforward telling of a noble life. For this he has been recently allowed to take down from the lips of Mr. Milburn, the blind preacher, long passages of autobiographic interest and personal utterance, which he had treasured up carefully with the unforgetting retentiveness of the blind ever since he heard Carlyle speak them in the course of frequent and cordial interviews now nearly twenty years ago. In the chapter in which Mr. Guernsey analyzes and quotes from the "History of the French Revolution," he is enabled by means of Mr. Milburn's memory to give us Carlyle's own account of the destruction by fire of the second volume of the precious MS., and of his conduct beneath the blow. He cleared his mind by reading nothing but novels for weeks. "I was surrounded by heaps of rubbish and chaff. I read all the novels of that person who was once a captain in the Royal Navy,—and an extraordinary ornament he must have been to it,—the man that wrote stories about dogs that had their tails cut off, and about people in search of their fathers; and it seemed to me that of

* An Earnest Trifler. Boston: Houghton, Osgood & Co. 1880.

† Thomas Carlyle: His Life: His Books: His Theories. By Alfred H. Guernsey. Handy Volume Series. New York: D. Appleton & Co. 1879.

* Sealed Orders. By Elizabeth Stuart Phelps, Author of "The Gates Ajar," etc. Boston: Houghton, Osgood & Co.

all the extraordinary dunces that had figured upon this planet he must certainly bear the palm from every one save the readers of the books. And thus refreshed, I took heart of grace again, applied me to my work, and in the course of time 'The French Revolution' got finished—as all things must, sooner or later."

Abbott on John.*

THE plan of this Commentary is admirable. It is for popular use; there is, therefore, no ostentation of learning and no lumbering apparatus of criticism. It treats lightly all those small points on which large sectarian divisions are founded. It treats fully questions of present debate among scholars. Discussions of chief points, such as the doctrine of the incarnation, the use of wine, the resurrection of Lazarus, and so forth, are found in special notes remarkable for their clearness. The work abounds

* An Illustrated Commentary on the Gospel according to John. For family use and for the great body of Christian workers of all denominations. By Lyman Abbott, D. D. New York: A. S. Barnes & Co.

in information given in a condensed and popular style. It is illustrated with many good, and some not so good, pictures. A great characteristic of the book is its fairness. Dr. Abbott belongs to the evangelical school, but he holds his opinions without a drop of asperity. He never calls down any fire from heaven, and he knows how to give an opponent's case all its proper force. He believes profoundly that the fourth gospel is the work of John, the son of Zebedee and the disciple of Christ, but he states the arguments on the opposite side with great fairness and force. It is a pity that there are not more people able to hold their opinions so charitably, so dispassionately, and with so much respect for themselves and others. Dr. Abbott gives us many judicious and learned expositions of the sayings and doings of Jesus, but better than all is his exemplification of the Christian spirit in his liberality toward those who differ with him. It is emphatically a commentary for Christian workers and for the family, as the title implies; and we know of nothing old or new better fitted for the purpose.

THE WORLD'S WORK.

New Drawing Apparatus.

A NEW apparatus for assisting artists and draughtsmen in making drawings of buildings, landscapes, figures, and other irregular objects seen in perspective, employs a table made in two parts, one portion being of clear glass, the other of wood. The table is pivoted on a standard, so that it may be placed at any angle, and when in use is secured nearly upright in front of the object to be copied with the glass portion uppermost. From the lower end is suspended a rod, that may be raised or lowered at will, supporting a pantagraph, the tracing point of which rests on the glass, while the pencil rests on the wooden part of the table. From the frame that surrounds the glass extends an arm, bent at right angles, so as to bring the end in front of the glass. At the end of this arm is a small hole or sight. In use the apparatus is placed before the statue, building, or other object to be sketched, and this arm is adjusted so that when the eye is at the sight, a view of the object can be obtained through the glass. Drawing paper is placed on the wooden part of the table, and the pantagraph is adjusted so that the tracing point may be moved over the glass while the pencil moves over the paper. The operator, looking through the sight, causes the point to move over the glass in line with the object seen following its outline, and chief lines, while the pencil at the same time gives a reduced copy on the paper.

The apparatus appears likely to prove of some value as an aid in making copies of statuary, figures and irregular buildings, as a preliminary in making more finished pictures. It may also prove of use in illustrating the principles of perspective in drawing classes.

New Tube-Cleaner.

OF the great number of appliances for cleaning boiler tubes, both by scrapers and brushes, the latest and most novel machine is a revolving scraper designed to be driven by steam. At the end of an iron pipe, that is at once handle and steam pipe, is fixed a rose-shaped scraper. Inside the pipe is a helix, or wheel with curved wings, free to turn in the pipe and secured to the rose-head scraper. Steam is admitted at the lower end of the pipe through a flexible hose. A stop cock is provided to control the steam and the machine has two wooden handles for guiding the apparatus. The scraper is thrust into the tube to be cleaned and steam is let into the apparatus escaping at the end, causing the helical-wheel to revolve quickly. Air at the same time is drawn into the pipe and the mingled steam and air escape into the tube at the end. The wheel causes the scraper to revolve as it is pushed forward, the steam softens and loosens the dirt, driving it forward and out at the other end of the tube. The novelty of this device consists in giving a rotary motion to the scraper by means of the steam jet. The apparatus, it is reported, will enable one man to clean one hundred tubes in about twenty minutes, and as the work is done quickly, it may be repeated every day at a material gain in the useful effect of the fuel. The idea seems to be one that could be applied to the cleaning of all kinds of flues, tubes and pipes, for either gases, smoke or water.

Steam Pavement Rammer.

THE work of driving down the blocks used in paving streets can now be performed by steam-power by a new machine constructed on the plan of the ordinary steam-hammer. The machine consists

essentially of a crane mounted on four wheels, the longer arm of the crane being pivoted and free to turn in any direction within a half circle, the shorter arm supporting a counter weight that is at the same time a fuel box. The boiler is upright, and placed in the center between the forward pair of wheels directly behind the movable portion of the crane. Attached to the boiler is a small engine, with the proper connections for propelling the engine along the road. At the end of the crane is a small steam-hammer, controlled in the usual way by hand-levers, and supplied with steam from the boiler through flexible steam-pipes. The steam-hammer has a heavy iron head, that gives downward blows on the pavement as the machine advances along the newly paved road. The apparatus only requires two men,—a fireman and an engineer,—to control it. The engineer stands by the hammer and delivers the blows at will, either lightly or heavily, fast or slowly, as may be required, moving the crane about from side to side by hand, and spreading the work in a half circle in front of the machine. To advance the rammer, the engineer starts the propelling engine, and another half circle of blows may be delivered. The work done by the machine is reported to be very thorough, the pavement being driven down firmly, and making a smooth, hard, and silent road that it is estimated will outlast any form of hand-finished work. The machine works at a high speed, and does the work of ten men in a day.

Electric Balance.

THE electric analysis of metals is again tried by an ingenious piece of mechanism, employing two induction coils placed side by side, and so arranged that their currents are balanced and neutralize each other. The coils are connected with three elements of a Daniell's battery and a small clock and a telephone. When the apparatus is adjusted, the clock is held in suspense by the currents and gives no sound. When a small piece of metal is placed on one of the coils, the balance is destroyed, and the clock is heard to tick through the telephone. A second piece of metal, of the same size and kind, placed on the other coil restores the balance, and the clock stops. It is proposed to use the device as a detective in examining small pieces of alloys and metals to find their composition. It is estimated that if a stated metal of known quality and weight will produce a certain action in the balance, it will make a standard of reference for examining other metals in the same manner.

New Uses for the Flexible Shaft.

THE flexible shaft, described, at the time of its introduction, in this department, has not only found a useful position in industry, but new uses for it have been frequently discovered. It is now used for cleaning castings and in sand-papery wood-work. For cleaning castings, a new form of brush has been introduced. Two iron discs, about 10 c. m. (four inches) in diameter, are placed on a spindle and connected together by a number of short iron

rods arranged along the edges of the discs. This makes a circular iron cage, and to the bars are fixed short links, each carrying a piece of steel wire. This makes a circular brush of wire that at rest is limp, the wires hanging loose. Affixed to a flexible shaft and driven at a high speed, the wires stand out like a stiff brush by the centrifugal force; and brought to the casting to be cleaned, the brush performs better and quicker work than can be done by any other form of brush. Being pliable, the brush readily fits into irregular corners of the casting, and takes the place of hand-work. For sand-papery with the flexible shaft, the sand-paper is cut into discs, and a number of these are placed on a mandrel, with small washers between the discs. This makes a sand-papery brush that can be used till worn down to the center.

New Method of Obtaining a Temporary Blast.

IN steam fire-engines, where it is essential to raise steam quickly, a strong blast for the fire is needed before it can be obtained in the usual way from the exhaust steam. To obtain this preliminary blast an exhaust-fan is placed in the smoke-stack near the top. This is driven at a very high speed by clock-work, and produces a very powerful blast. In experiments with an ordinary steam fire-engine, with cold water in the boiler, the flame of the fire was drawn out the top of the stack, and the steam gauge began to move in forty-five seconds after starting the fire. In four minutes the gauge showed a pressure of forty pounds. This is less than half the usual time needed to obtain this pressure. As such a clock-work blower would soon run down, and as it would not be needed after the engine is at work, it is presumed that it is stopped or taken out after the steam is raised. Such a temporary blast would be useful in the chimneys of all kinds of furnaces where it is necessary to secure a high temperature in a short time.

Memoranda.

By a new method of making cylindrical boilers a seamless cylinder of steel is produced that is in one piece, requiring only to be fitted with ends to be complete. A cast steel ring of the diameter of the proposed boiler is heated and placed upon a large roller and then, by means of other rollers, it is rolled out lengthwise, thus making a hollow cylinder of steel without seams. End pieces are riveted on in the usual manner and the boiler is ready for use as soon as the fittings are put on. The machinery needed to roll such a cylinder is expensive, but the result is a boiler shell of unusual strength and durability.

In curing beef for export the experiment has been made of injecting brine into the entire carcass. On the instant of killing, the heart is opened and a pipe is inserted in the left ventricle and a current of weak brine is driven under pressure through the blood-vessels, washing out all the blood. This done the right ventricle is plugged, or clamped, and strong brine is driven in until the entire sys-

tem is charged with brine. It is reported that the brine is thoroughly distributed and the meat effectually cured.

Wicks for oil lamps have been recently made of fine threads of glass woven with cotton. The cotton threads are destroyed in the flame and the top of the wick is then wholly of glass and feeding the oil to the flame for a long time without trimming. If the glass becomes fused at the end or clogged with residue from the oil the end of the wick may be broken off over a sharp edge, when the wick may be turned up slightly. The wick is reported to give a clear, steady flame and to last in use a long time.

In a new form of electric current-breaker advantage is taken of the sonorous vibrations of strings. A wire is stretched between two points, and to the center is fastened a small platinum point turned downward and just touching a cup of mercury below. A small magnet is suspended over the wire, and the wire and cup of mercury are made parts of

an electrical current. The action of the current passing over the wire to the cup and under the magnet tends to make it vibrate by the elasticity of the wire, thus lifting the platinum point out of the mercury at each vibration, and so breaking the circuit. By changing the length of the wire, and changing its note, or the number of vibrations, the breaking of the circuit may be modified at will.

In using excessive pressures in limited areas for the purpose of solidifying powdered substances, it has been found that the die used to press the powders into the mold would bend and "buckle" before the higher pressures could be used, and to obviate these thin discs of hardened steel have been used with success. One disc is put on and the pressure applied, and when the disc sinks into the mold another is added and the pressure renewed. By using a succession of discs very high pressures have recently been obtained thus giving some new results. The mold and discs must be dusted with powdered plumbago before using.

BRIC-A-BRAC.

The Star.

YEARS ago, way up in heaven,
Bloomed a shining star,
And at midnight came an Angel
Flying from afar.

For she heard the star complaining
Of its bitter fate;
'Twas so small, and yet its Maker
Made so many great.

"Hasten straightway," said the Angel,
"To Jerusalem!
God has made you,—thankless Spirit!—
Star of Bethlehem!"

W. T. PETERS.

Dictation Exercises.

"Miss Calline, you aint got no time to rite me a letter, is you?"

I looked up from the sewing I was eagerly trying to complete before dark, as these words fell on my ears. After a busy morning and late dinner, I had gone to my room, promising myself an afternoon of undisturbed rest. Just at the luxurious moment when I had thrown myself on the couch, with every care resolutely banished, my sanctuary had been invaded by the patter of little feet, and a very tearful pair of eyes had peeped in the door. My half-shut eyes could not resist the heart-broken sigh, that told me the intruder was my five year old name-sake, Carrie.

"What is it, pet?"

"Oh Auntie, I is wited to a party, a real sure 'nough party, and mamma got—got a headache, and she can't finish my dweess, and I must not 'sturb you, and I do want to go to a party."

Poor little aching heart could bear no more, so bursting into tears, she threw her golden head into my lap.

Folding away my disappointment, I soon quieted the storm by sending her for the "dweess." Fortunately, there was not a great deal to be done; my prospects of rest grew brighter as my rapid fingers kept pace with Carrie's eager talk about the party.

Our cozy chatter had been interrupted by the sudden opening of the door, and the above salutation.

All Southern readers know, if you ever promise the negroes anything, they claim fulfillment at the most inopportune time. As soon as I heard the question, I recalled one of my rash promises.

Looking up, as I said, to my dismay I encountered the beaming smiles of two blooming maidens of African descent. About a month previous I had promised Nancy Joyner, the younger and more smiling of the two, to write a letter for her, but had forgotten all about the promise until now, in all the assurance of successful appeal, she came to remind me of it. Nancy was as homely a specimen of her race as you would care to see, but the elaborate care bestowed on her toilet gave evidence of her appreciation of adornment.

Her attire was a study. A white lawn underskirt trimmed with many narrow ruffles, contrasted finely with a pea-green overskirt, shorter behind than in front, confined to a blue lawn Garibaldi body by a dark-purple sash, tied at the side. A scarlet necktie and large bow added to the effect. A large chignon of black jute, tied with pale-pink ribbon, surmounted by a white straw hat, bound with purple and trimmed with rows of narrow green ribbon and long streamers of white illusion, gave an air of jaun-

teness to the startling array. As I caught a glimpse of this figure, strong in the consciousness of well-dressed womanhood, my vexation speedily dissolved in a smile of welcome.

Judy, her companion, was more subdued in appearance and manner, but her many nudges and grimaces plainly showed she was an interested party in the affair. I invited the girls to enter, told Nancy that, although I was very busy, if she would tell me what to write I would soon have the letter ready for her. It seemed such a small thing to write a letter that I never thought of refusing. We always treat the negroes, even now, as so many children, and dislike to disappoint them.

"Well, you see, Miss Calline, I got dis hur letter gwine on two weeks ago, an' I'se been a-layin' off to git you to anser it fur me ever sence. So I jist thought I'd step down hur this evenin' an' git you to do it fur me. Judy, she's got more gumption dan what I is, so I fotch hur 'long to help me wid it. Hur's de walloper an' de paper. I never fotchted nary scrotch, 'cause you's writing so much I thought you had plenty of dem."

With these words she handed me an envelope and a crumpled sheet of paper, which had evidently been on intimate terms with the pots and kettles. I folded up my work and rose to get my writing-desk, when Carrie made a sudden assault on the intruders.

"Now, Nancy, you just let my aunty 'lone! She aint going to write no letter for you, you ugly old thing, 'cause she's busy wid my new frock."

Nancy caught her up in her arms, gave her a hug and a kiss, promised to bring her a little black chicken, and tossed her over to Judy, who also hugged and kissed her, and promised to bring her something pretty if she would let aunty write the letter.

Carrie, pacified and curious, seated herself at my feet, while Nancy and Judy stood at the back of my chair to carry on a conversation in whispers, of which giggling formed the chief item. After waiting for some minutes, pen in hand, I remarked:

"Now, Nancy, I am ready. What must I say?"

"De laws, Miss Calline, you knows how to write."

"Yes: but I don't know what you want to say."

"Laws, 'pears like if I had your larin' I could jist write anything. Couldn't you, Judy?"

Pause second. At last:

"Well, must I address him as your friend?"

"De laws, Miss Calline, what you reckon I want you to pot clothes on dat nigger fur?" and then they both burst into a loud laugh.

I alter the question with a feint of object teaching.

"Shall I write down here"—showing the place—"My Dear Friend?"

Nancy is not equal to this demand upon her resources, so applies to Judy.

"Would you say dat, Judy?"

"No, I wouldn't, 'cause his letter was Resteamed Miss Jines, and ef you goes a-calling of him 'dear' fust he jest go to potten up himself, and gentlemuns pots on airs 'nuff any way."

"Dat's so; well, den, Judy, what you gwine to do den?"

They both stand still, Judy in an attitude of deep thought, Nancy complacently gazing at herself in my mirror. After waiting a short time, in despair of getting a decision, I ask:

"Shall I say Mr.—what is his name, Nancy?"

Nancy brightens up, and answers, with alacrity:

"Mr. Silvestur Corpul Junnior."

"No, Nancy 'taint Corpul; it's Corpin."

They then have a dispute, in which each cites authority for her own mode of pronunciation with equal ardor. To expedite matters I ask to see the gentleman's letter.

Nancy, with a queer look of chagrin, says:

"Well, dat 'll do, ef I aint de most no 'count, good-for-nothin' poor nigger de Marster ever made. I spects I lef' dat letter out on de wood-pile when I was cottin' wood, and it done blowed away. I knows 'taint nowheres in my pocket." She dives into some unseen receptacle, but fails to produce the missive.

"Well, never mind, Miss Calline, so you puts de Junnior. 'Twont make no difference 'bout de tother part. Ef you don't put de Junnior his daddy might git it, so he tole me always to put dat to it, so I tied a knot in a string to make me 'member 'bout dat."

Judy is appealed to in support of this position.

After nearly a half hour of wasted time, I pen "Mr. Silvester Corpul, Jr."

"Shall I acknowledge—oh bother! I mean shall I tell him you got his letter?"

"No, Nancy, dat I wouldn't do, no sich a thing. Cause he might 'think you didn't, and den he will write ag'in," interposed the politic Judy in a loud whisper.

"Dat's de truf. No, marm, jest put—law, Miss Calline, you ought to know what to put, much schooling as you's had."

Carrie here cries out:

"I don't want no old black chicken! You go right home, Nancy, an' let my aunty sew on my frock."

As my precious time has slipped away so rapidly, I write a few lines in the vain hope, that some light will dawn on my dictators.

Nancy at last has a happy thought, and with face aglow with excitement says:

"Miss Calline, tell him I's bin to two balls dis week; de Lord knows I aint bin to nary one, but you tell him dat."

"Nancy, that is a story."

"Well, anyway, I 'spects to go to one some time or 'nother, so you jest tell him I done bin."

I write as per order for a few words, when Nancy asks:

"Is you got dat down, Miss Calline?"

Now thoughts flow apace and she goes on:

"Tell him his mother is well, an' she sends all her love, an' she's mostly poorly, thank de Lord, an' she has dat same misery in de back, an' will he send her dat little change, an' she hopes he keeps on a-prayin', an' is you got dat down, Miss Calline?"—all in one hurried, breathless sentence,—“an' Miss Weels, she sends him all her best love.”

"Now Nancy, what you do dat for? I aint gwine to send my love to your beau," cries the delighted Judy.

"Is you got dat down? Tell him, Mr. Boly he say long as he's lef' dese parts what fur he writin' love down dis way fur, an' tell him,—oh Miss Calline, you ought to know how folks 'rite to dere beaus. I know you is rit to your beau often enoff."

"Why did you not tell me at first that he was your beau? I thought he was only an acquaintance;" and I tear up what I have first written, as the words seem out of place under the new state of affairs, and begin anew.

"Miss Calline, you see he aint jest rightly what you kin call a beau, but he sed—what was it he sed, Judy?"

"He sed, how in his letter dat he felt like if you would speak de word of de intention to him, he incline to feel so beateous happy, he think he got 'ligion, de delightfulness of his state would be so splendid."

"Oh yes, now I ricollects, I study so hard to remember, but 'pears like I aint got no sense when folks talk big Dick talk. Miss Calline, tell him I wish him de best o' de pickin's an' no nobbins round, I hopes he is a-keepin' up a good heart—an'—an'—an'—Judy Weels you kin read and rite; why don't you tell Miss Calline some big Dick to put in? You knows big talk mor'n I do."

Nancy gives a deep sigh, wipes the perspiration from her face on the lovely overskirt, and retires exhausted from her intellectual efforts.

Judy asks me to read what I have written. I begin:

"MR. CORPRIL JUNNIOR.

I take pleasure in telling you of the welfare of your friends. I have been to three balls this week —"

Here I am interrupted by Nancy, who asks if I have room to put in "Dot I danced wid a gentlemun dot sed he never seed such lovely ladies as he seed dot night, and would I give him de pleasure of my attendance."

Evidently, Nancy improves on her fiction. I insert the above, and read on until I come to the message from Mr. Boly.

"Wont dat make old Silvy mad to hear I is keepin' company wid Ned Boly agin?" Nancy again interrupts to say. "I told him I never was gwine to speak to him no more."

When I get to "the keeping a good heart," Judy has forgotten what she intended to say after that sentence, and another long pause ensues. I have been fast losing patience, so tell them to hurry up or I shall have to stop.

Judy at last triumphantly exclaims—

"Keep a good heart, and wish him all de enmity of good luck, and when he comes to die may his last end be like his, amen." They again pause to deliberate, so much pleased with this sentence, they do not dare to disturb its effect on their self-esteem.

"Nancy, is that all?" I cry hotly.

"Tell him I wish him de best of de success

in his coortin', an Miss Smith she say he is hur beau, an' if you is in love wid her, what you come writin' to me to have my picture drawed fur you to take next to your heart, fur I aint poor for no beaus, fur I kin git married as soon as I wants to, I kin. And tell him to give my love to all inquirin' friends, an' de laws, Miss Calline, you aint sed I takes my pen in hand to rite dese few lines, hopin' you is well. Please marm to put dat down, an' I is well, and hopes you is in de same good luck, and of the same mind, an' times is hard an money is scarce, and don't git better. I's leaving dis place. An' your mother, she sends her love, and says send her dat little change, as money is scarce an' times is hard."

My patience is rapidly disappearing, so I write each sentence just as dictated.

"Give my love to Mr. Davis, and Miss Walker she sends all her love, an' I lives in de hopes of seeing your lovin' face, and I pines for de day when you will come back, and dere is no change in me, but I sticks to what I sed and I is of de same mind still. I hopes you will not forgit dat I is your true lover and sweetheart,

Till deth,

NANCY JINES."

"But, Miss Calline, ef dere is any room, please put dis in: 'De sea is blue, de earth wide, my love for you is more dan true.'"

At last the interesting epistle is finished. With a provoked smile I read the whole of the wonderful production, and wonder what some of my correspondents would say could they peep over my shoulder. Nancy and Judy listen in admiring silence, and when I conclude express their opinion to the effect that I am a prodigy of learning, and as a reward for my wisdom promise to get me to write them another letter very soon.

At last, with a bow and curtsy, they take their leave.

I do not know about the learning, but I am thoroughly convinced that I am a prodigy of patience as I light the gas to bestow wonderfully long stitches on poor Carrie's party "dwees."

VIRGINIA S. IMLIA.

Les Morts Vont Vite.

(RONDEAU.)

Les morts vont vite: The dead go fast!

So runs the motto France has cast.

To nature man must pay his debt;

Despite all struggle, despite all fret,

He journeys swift to the future vast.

It needs no ghost from out the past,

To make mere mortals stand aghast,—

To make them dream of death—and yet,

Les morts vont vite.

Although the sails (bellowed by blast)

Of Charon's barque may strain the mast—

The dead are not dead while we regret;

The dead are not dead till we forget;

But true the motto, or first or last:

Les morts vont vite.

J. B. M.

A Reply to "Speaking Features."*

WHENEVER I talk to my sweetheart,
Of aught that is flippant and light;
He gives me such excellent answers,
I find myself thinking him bright.

But then, if I grow very learnèd,
And tell him about the last book;
He says, "Ahem! Yes. Why, I'll read it,"
With an imbecile, far-away look.

And then, if I sing him a love-song,
He giveth his watch-chain a twirl,
And immediately asks for "Whoa-Emma."
Ah! I *am* a fortunate girl. P. C. S.

Song.

SPiRiT of the Summer woods,
Breathing through far solitudes,
Hasten! for the north wind blows;
Shortly fall the wintry snows;
With the birdling and the bee,
Soon thou'lt find no room for thee!

Spirit of the Autumn groves,
Where the footstep idly roves,
And the rustling leaves around
Whirl and settle on the ground,
Haste thee, for the gentian blue
Bids the world and thee adieu!

Long ago the violet fled,
And yarrow by the river's bed;
Long ago the golden-rod
Faded, and the silk-weed's pod
Sowed with silvery flakes the air,
Floating, hovering, everywhere!

Now the fox-fire on the hill
Shows that nights grow dark and chill;
While the glow-worm by the stream
Faintly shines with faded beam;
And asters 'mid the leafless bowers
Shut the daytime of the flowers!

Draw the curtains; close the door;
Bid the hickory blaze and roar;
Make the beggar's want thine own;
Rest the weary; cheer the lone;
Then, old Winter, come with me—
Thou my guest and song shalt be!
WILLIAM M. BRIGGS.

Epigrams.

FRIENDSHIP.

Too near the fire, you burn,—
Too distant, freeze in turn;
As fire regard your friend,
Lest friendship have an end.

WISDOM AND HAPPINESS.

WHO deems himself a happy man
Happiness in him lies;
But wisdom has small part in him
That deems himself as wise.

THE UNIVERSAL LANGUAGE.

AS time draws to an end, 'tis plain,
Languages must diminish,
Till, at the last, but one remain,
And that must be the Finnish.

THE EPIGRAM.

THE diamond's virtues well might grace
The epigram, and both excel
In brilliancy in smallest space,
And power to cut, as well.

A COQUETTE.

HER pleasure is in lovers coy;
When hers, she gives them not a thought;
But like the angler, takes more joy
In fishing than in fishes caught.

FAMILY JARS.

THOSE little tiffs, that sometimes cast a shade
On wedlock, oft are love in masquerade;
And family jars, look we but o'er the rim,
Are fill'd with honey even to the brim.

"A SOFT ANSWER."

AN angry word her lips was struggling through,
But, from those rose-gates, all unconscious drew
Such sweetness, that it to the hearer seemed
A gentle balm, that with forgiveness teemed.

GEORGE BIRDSEYE.

Is Life Worth Living?

THE BABE.

BEGUN!—and round me glowed
Huge masks, with staring eyes—
And smiles alarmed me more—
I after saw in pantomimal story.
I had no sense of time: nor overmuch
A sense of anything:
I woke!—my eyes confronted with a glory
That made them open more and more,
It seemed they'd crack to take it in:
Anon, a wall of black would supervene,
I'd try to fight it off, and cry aloud!—
The light was out!—
Brief, brief candle!

THE LOVER.

Another spell—'twas not the one at school,
Yet taught me more than aught beside:
A being like myself,
But unlike more—a finer—fairer—
To every sense and thought gave newer zest
And newer meaning.
How great had been the void
That now was brimming o'er!
What measure's depth could hold it all!
Riches untold: a world unknown before:
The idol!—and I worshipped.
'Twas burning then, was life and love—
Brief, brief candle!

THE OLD MAN.

'Tis further on: I've staying power—
For friends are gone, snuffed out
As though they ne'er had been—
Whilst I, who miss them here, live on alone!
A retrospect of graves
And just ahead—my own.
There's over all a ghostly hue—
And rosy, golden day no more
As seen with infant's, lover's eyes—
The flame of life is burning blue!
And dwindling—near the final flicker!

But at its best it gives me handle
To ask if it were worth the candle?

Brief, brief candle! G. J. A.

* "Bric-à-Brac" for July, 1879.





PETER THE GREAT.

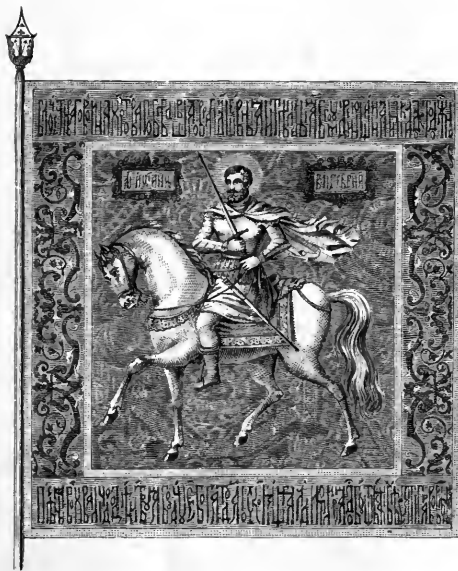

RUSSIAN FLAG OF PETER'S TIME.

Editor Scribner's Monthly

Dear Sir

I have read
the paper by Mr Francis Upton and it is
the first correct and authoritative
account of my invention of the Electric
Light

Yours Truly

Thomas A Edison.

Menlo Park N.J.

[SEE PAGE 531.]

MIDWINTER NUMBER
OF
SCRIBNER'S MONTHLY.

VOL. XIX.

FEBRUARY, 1880.

No. 4.

A WHEEL AROUND THE HUB.



RECREATION AT MASSAPOAG. (SEE PAGE 496.)

THREE countries claim the birth of the bicycle. Whether the paternity of it really belongs to a German baron, to an English postman, or to a French mechanic, we may leave to the debates of the curious, or answer with the safe suggestion that it is the result of a process of evolution, while we enjoy the fact, that whatever its origin, it is now an American institution. An instrument with which M. Laumaillé has threaded thirty thousand miles of European roads,

VOL. XIX.—35.

with which Mr. Waller has accomplished more than fourteen hundred miles in six days, and which on any course longer than five miles enables a man to excel the fleetest horse, is one which may well excite the public interest and find its way into the popular literature of the time. If it were adapted only to the racing path or the public hall, if it had only its record in competitive and ornamental athletics, its use might be characterized as a fashion in

[Copyright, 1880, by Scribner & Co. All rights reserved.]

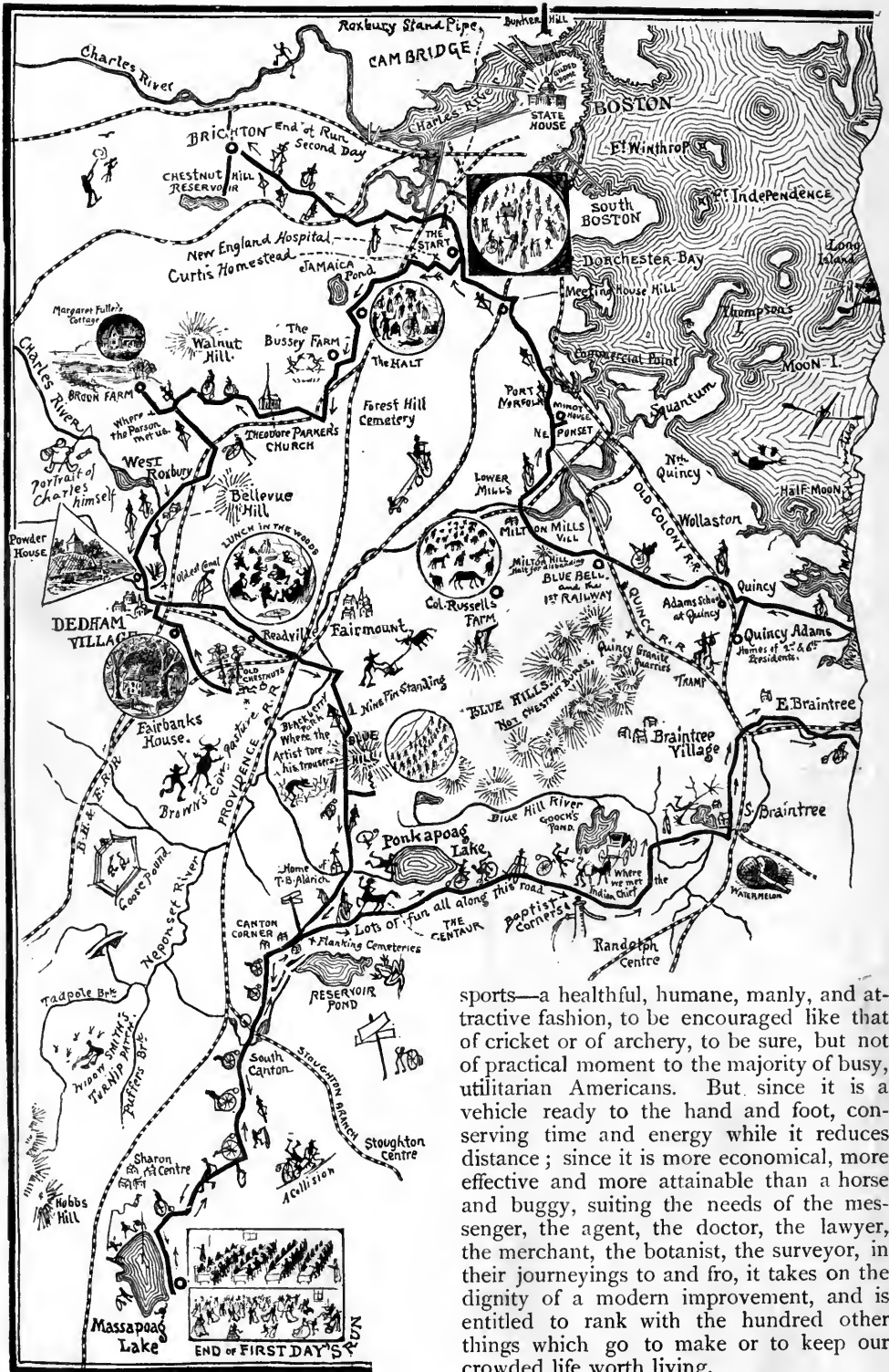

sports—a healthful, humane, manly, and attractive fashion, to be encouraged like that of cricket or of archery, to be sure, but not of practical moment to the majority of busy, utilitarian Americans. But since it is a vehicle ready to the hand and foot, conserving time and energy while it reduces distance; since it is more economical, more effective and more attainable than a horse and buggy, suiting the needs of the messenger, the agent, the doctor, the lawyer, the merchant, the botanist, the surveyor, in their journeyings to and fro, it takes on the dignity of a modern improvement, and is entitled to rank with the hundred other things which go to make or to keep our crowded life worth living.

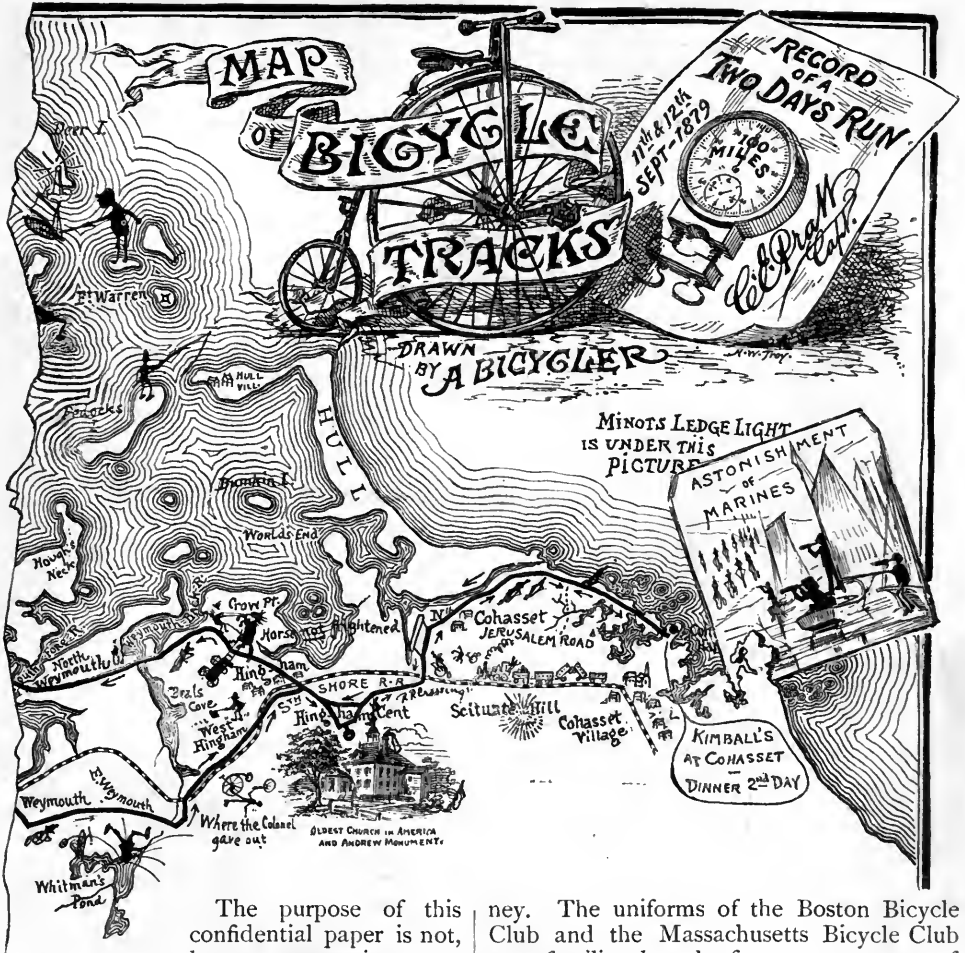

The purpose of this confidential paper is not, however, to praise or to disparage this modern rival of the horse, but to disclose how a few possessors of the birotate chariot, numbering some forty odd, enjoyed "a wheel around the Hub," as our Artist put it, and to record some of the events of their two days' run.

The meet was entirely informal. Personal invitations had brought together individual members of seven or eight bicycle clubs, and also several amateurs from the unofficered ranks of "the unattached." A rosy September morning smiled on them as they glided by ones or twos toward the place of meeting. This was the foot of a broad, winding avenue in ancient Roxbury, now a part of the municipality of Boston. Roxbury had seen many bicycles before, but never so many at once. There was something novel in the diversity of dress, in the equipments with knapsacks and compact "*multum-in-parvo*" bags, portending a jour-

ney. The uniforms of the Boston Bicycle Club and the Massachusetts Bicycle Club were familiar, but the fine gray costumes of the Worcester Bicycle Club, the white flannel shirts and bright stockings of the Hartford, and the blue polo caps, marked "E. Bi. C.," and the strange attire of the Newark, Washington, and Salem men, were remarked by the early-moving business men, on their way to town. Carriage people reined up to look, and teamsters to have a pleasant word; the street circulation of Roxbury had a stoppage. The community went into committee of the whole to consider a novel state of facts and canvass the prospects; ladies smiled from the windows and piazzas, children thronged the walls, and the irrepressible small boy shied his cap at the gleaming spokes and cried, "Mister, your little wheel's loose!"

As is usual with things "informal," the meet had a contriving head or two behind it, and the fact began to be apparent when a spirited horse with buggy attachment,

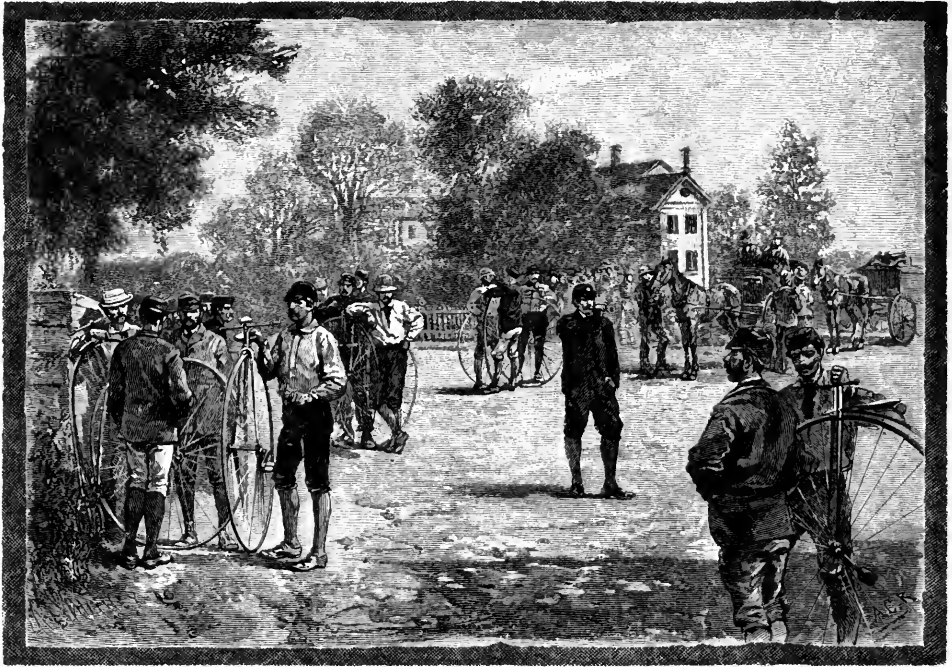

THE MEET, ROXBURY.

and a similar antiquity with a light express wagon and driver, surrendered to Praed, who directed Apollo and our Artist to the first, and invited the knapsacks and other *impedimenta* to the second. Meanwhile Ned was handing about some manuscript copies of something which an eager reporter, who chanced along, explained to his companion was "a programme."

The committee aforesaid had become a crowd. It rained questions and witty remarks.

"Pile machines!" exclaimed Quil,—an order equivalent to "stack arms" in a military company. The effort was futile, and revealed a need of leadership. Praed was requested to assume command. Calling his motley hosts to one side, by a thrice repeated



"OTHELLO'S OCCUPATION'S GONE."

"attention" with a small bugle, he addressed them with terse directness if not with eloquence. The organization was simple. Five aids were appointed, namely, our Highland

Laddie to ride at the front with the captain, Quil and Old Easy to ride at the rear, and Ned and Squire Winsome for intermediate duty.

Just as the fortieth came wending his way laggardly through the crowd, the captain's bugle sounded "boots and saddles," and the mount was effected. Fluttering handkerchiefs of ladies receded fast, and fresh scenes opened to view as the rubber-hoofed steeds sped noiselessly along the winding avenue, across and beyond the busy streets, past fine new mansions and quaint old houses. Here was the New England Hospital set like a castle on a sunny slope; here, the ancient homestead of William Curtis, established in 1638. Tradition has it that, with very few changes, this is the house he then built; and from that time to this, continuously, he or some of his descendants have dwelt here. William Curtis was the progenitor of nearly all the numerous families of that name now in the United States, including the late distinguished jurist and him who graces the jolliest easy-chair in the domain of literature.

Arrived on the eastern strand of Jamaica Pond, a charming sheet of water between pretty hills, at signal of three short notes the bicyclers dismount and discover the third evidence of foreordination

for this informal run. They had been preceded by a genial and accomplished knight of the camera, whose gentlemanly address had obtained leave of the residents, and whose artistic eye had selected a fine little lawn, bounded by an elegant country residence and the street, a hedge and a grove of young trees, as the best field for taking an impression of the pleasure-bound charioteers. His camera was set in position near the hedge, and at his invitation the company filed in, piled wheels, and grouped itself for a rest and a photograph.



PEGASUS PUZZLED.

Scarcely was the party at ease, however, when a buttoned and "billy"-bearing embodiment of the majesty of the law entered the enclosure, and growled:

"You're trespassing on private property here; get into the street!"

"No, sir," blandly interposed Mr. Notman; "I have obtained permission of the residents."

"arrest every one of ye!" retorted the lone policeman, now irate, and describing incalculable curves with his billy; "take them things and leave!"

"Shall we duck him in the pond, Captain?" asked Old Easy, drawing up his athletic figure.

"Mr. Officer," said the Captain, "we have a right here, and you are out of your jurisdiction."

"None of yer slack to me! The folks in the house don't own this property. I'll have this ground cleared or ——"

"I intend you no disrespect," answered the Captain, advancing, "but if you do not leave at once I shall report you to the Commissioners of Police. If you make the least disturbance here I shall, as a justice of the peace, make you my prisoner."

"The law is clear; we'll back you," added the Squire, amid a general clapping of hands.

"Clear these traps off, or I'll smash 'em over the fence," exclaimed No. 626, retreating toward the camera.

"Touch that, and I'll prosecute you for malicious mischief!" ejaculated the Captain, —and then added, with a sarcastic smile: "Don't you think, my friend, that one set of buttons is rather lonesome here, against a body of forty able men?"

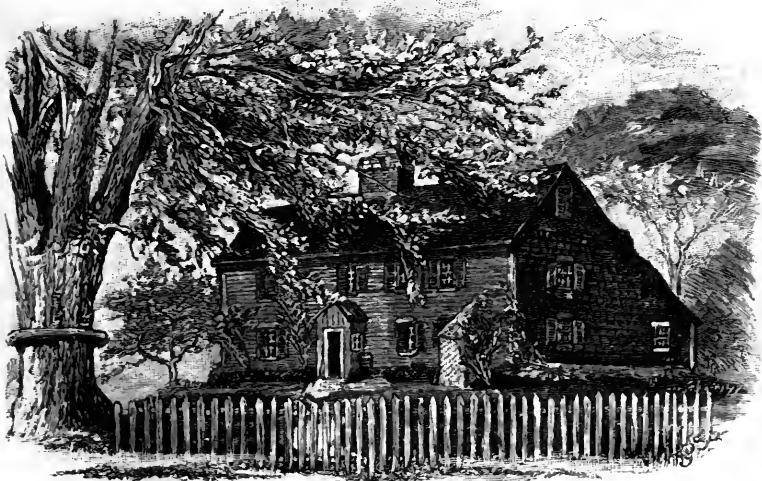

THE OLD CURTIS HOUSE.

"Put him out!" exclaimed Cruikshank, unguardedly.

"Oh, take his picture!" said the Irrepressible.

"Now you git out o' here quick, or I'll

The faithful guardian of persons and property, yielding perhaps both to the argument of numbers and to his own calmer reason, walked away. Our Artist in the meantime had sketched him with nice



accuracy in expression and attitude. When the halt was ended, and all returned to the street for a mount, No. 626 was as genial and chatty as any.

Again the spinning wheels flitted along the pleasant streets of West Roxbury two

of Massachusetts teamsters and drivers, whose obliging fairness to bicyclers was frequently remarked by the New York and New Jersey riders; or, again, of the little church, where Theodore Parker preached the first draft of his Discourse on Religion; or of the Weld Farm and its cider, or of other themes suggested by the wayside attractions of the route. Up hill and down dale they rode, through valley and over ridge, at eight miles an hour; it was a moderate pace, but there was much riding ahead, and this was the pursuit of pleasure, not of speed,—and how exhilarating it was!

The lead was down a winding hill toward Brook Farm. Two long notes from the captain's whistle—"slow up"—repeated along the line, was understood to mean "take the hill with care," and was obeyed by all but Froggie. His saddle had been set well up to the head of his roadster, so that he was nicely poised over the center of his wheel, which, getting the better of brake and back-pedaling, took on a speed of fifteen miles an hour, till suddenly meeting a stone, it stopped,—while Froggie yielded to the force of circumstances, and took "a header," in process of which he left his bicycle for a moment with its little wheel reared aloft, reached out his hands to Mother Earth, and kissed her frantically, while his high-



IMPRESSIONS OF BROOK FARM.

tempered steed lay down docile at his side. He rose with an absent-minded smile, remarked that he gave our Artist (who, sketch-book in hand, was following in the buggy) an opportunity for a study of action, remounted and rode on.

by two; and now the social chat was of the quickly passed Bussey Farm annex of Harvard; now of the courtesy

So large a body of men in costume with implements of steel and hearts of loyal courage had not invaded Brook Farm since the second Massachusetts regiment of vol-

unteers was recruited here in 1861. "That was the best crop I ever raised," said the patriotic James Freeman Clarke, who, being then owner, gave the use of this two hundred and fifty acres to the state. One might easily believe his statement in the most literal sense, for this would seem about as poor a selection for a *farm* as could be made in fifty miles around. Whatever else the "Brook Farm Phalanx" were,—and these thirty-eight later years have proved them to have been a good deal besides,—they were not shrewd farmers.

The Captain led his band over the brook and to the left up a drive-way, and on by the wheel-tracks of a grassy and gravelly cart-road through the sacred acres. This way leads a half mile or more back from Baker street to a cemetery, which now occupies part of the former "farm"; but a dismount was made midway at the foot of a ridge of primeval gravel heaped on a pudding-stone ledge, and where from under the few shade trees some old sites, the meadows and the encircling hills were visible in rural repose beneath a forenoon sun. Froggie and the Doctor had halted at the entrance for a consultation. Apollo and the breakfastless Artist reined up their perspiring quadruped. Old Easy was detailed to forage for milk for the company and coffee and biscuit for the Artist; and the result of his errand proved the hospitality of the neighborhood and the appreciation of the visitors.

And this was Brook Farm—scene of the chief of socialistic experiments! Here met in brotherly and sisterly communion inspired and gifted men and women,—Emerson, Hawthorne, Channing, Ripley, Dana, Dwight, Curtis, Clarke, Hecker, Alcott, Bradford, Burton, Pratt, Parker and Thoreau; Mrs. Ripley, Miss Peabody, Margaret Fuller, Miss Ostinelli, Miss Bruce, Mrs. Diaz, Miss Russell, the Misses Dwight, and many more, not to mention the distinguished visitors and the pupils who have since become distinguished. Here, where they hoped to realize a higher type of fellowship—the only tangible monument of their industry to be seen—is a tiny rustic cottage, built in form of a Greek cross on the ground, one story high, with four gables, three porches, and a cupola, seated at the south-western end of the ridge. It contains four small rooms and a hall on the first floor, and a like number in the roof. Just below it is the old well; and a little to the westward is the place where the greenhouse and garden were, now partly overgrown with



A CHAPTER OF HEADERS.

scrubby young pines. The little house is now called "the Margaret Fuller cottage," and the tradition current in the neighborhood is that that distinguished woman contributed the money it cost and lived in it during her brief stay at the farm. When the "communitarians," as Hawthorne calls them in his "Blithedale Romance," came here, in 1841, there were only a farm-house and a barn on the place, near the road, and a short distance above the brook. That house came to be known as "the Hive." They subsequently erected the cottage and greenhouse referred to, and also a larger square two-story house, with a kind of parapet around the top for promenades, which was called

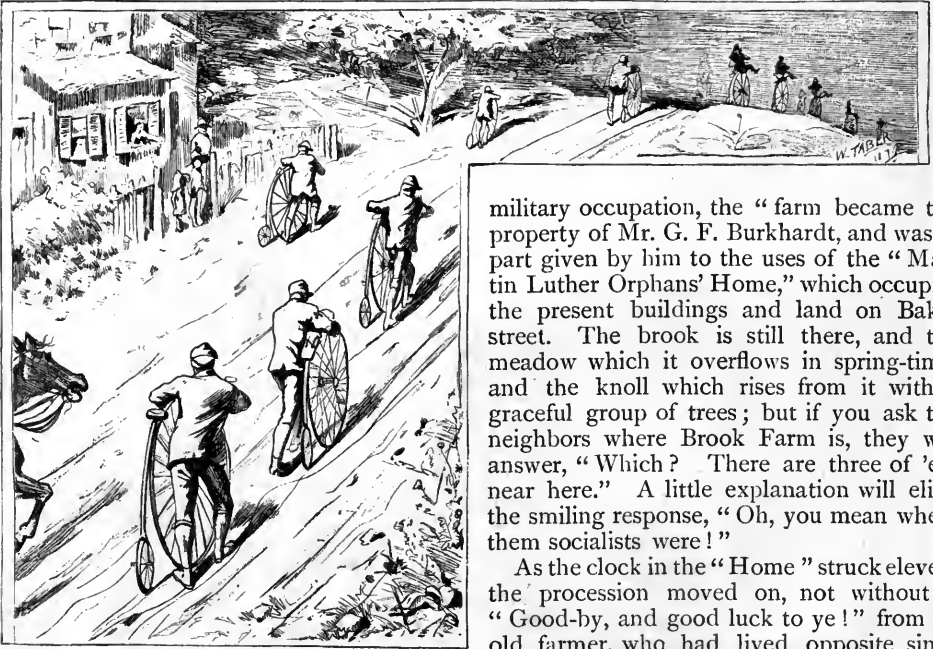

A MERCIFUL MAN IS MERCIFUL TO HIS BEAST.

“the Eyrie,” and was the favorite building, the cellar of which is still to be seen not far from the cottage. On the eastern brow of the ridge is the site of a still larger three-story building, which they erected with money borrowed on a mortgage of the real estate. This was called the “Phalanstery,” and when it was about completed, but before any insurance was effected on it, it took fire and was burned to the ground. This was a staggering blow; a dispersion followed; and in 1847, the Brook Farm Phalanx was a beautiful and pensive memory. “Where once we toiled with our whole, hopeful hearts,” wrote one in his note-book, “the town paupers, aged, nerveless, and disconsolate, creep sluggishly afield.” The town of West Roxbury did indeed take it for a poor farm. The romantic “Eyrie” was pulled down and put up nearer the barn for a sty, and four hundred hogs were housed within its consecrated walls. The “Margaret Fuller cottage” was filled with small-pox victims, and became a pest-house. In 1849, the city of Roxbury purchased it for a town-farm, and added a workshop, one end of which is still standing as part of a large annex to the present main building there; and about 1854, every building on the place, except the cottage and the part of the new workshop, was destroyed by fire. Subsequent to the ownership of Dr. Clarke and its

military occupation, the “farm became the property of Mr. G. F. Burkhardt, and was in part given by him to the uses of the “Martin Luther Orphans’ Home,” which occupies the present buildings and land on Baker street. The brook is still there, and the meadow which it overflows in spring-time, and the knoll which rises from it with a graceful group of trees; but if you ask the neighbors where Brook Farm is, they will answer, “Which? There are three of ’em near here.” A little explanation will elicit the smiling response, “Oh, you mean where them socialists were!”

As the clock in the “Home” struck eleven, the procession moved on, not without a “Good-by, and good luck to ye!” from an old farmer, who had lived opposite since



THE MASHER.

1848, and who took a kindly interest in the "hobby-horsemen," and recounted to them some of the traditions current about the place. His enthusiasm over their elegant aids to locomotion was quite puzzling until he narrated how he had seen the low "hobby-horses" of fifty-nine years ago driven on English roads by thrust of the toes on the

"O, no!" said the Masher; "but what would you call right down villainous, now?"

"You can't talk about roads with those

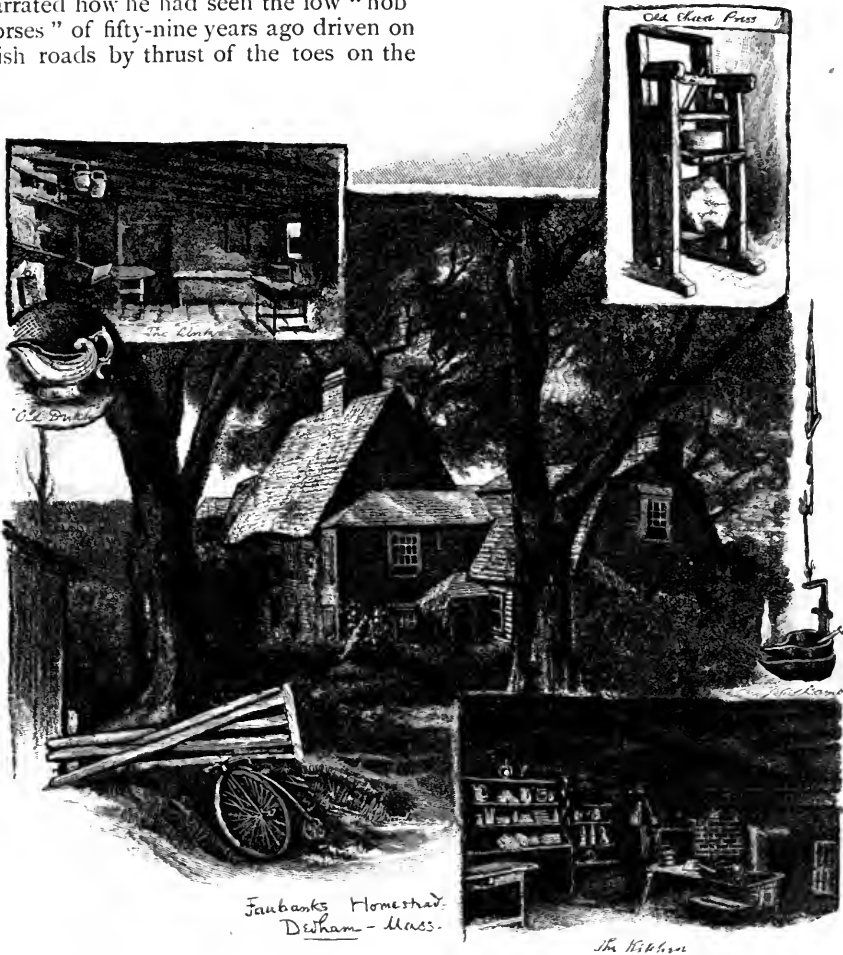

ground, when he was a subject of George the Fourth.

The village, a mile and a half away, was soon passed, and the route lay over worn turnpike, the worst of all roads for a bicyclist, except unmitigated sand. Here some of the less experienced toiled at a slower pace.

"If the aldermen would only ride bicycles, or change places with their horses!" complained the Masher, struggling toward a smoother band at the edge of the road.

"When they do, we shall have the streets attended to," answered Ned; "but this is not bad at all."

men who have toured it in New Hampshire," interjected Quil, the editor. "Now here's Ned, and there's the Squire and the Captain,—either of them will ride in two inches of dirt, or in a rut, or on a ribbon of grass, or in the ditch, or on a stone wall or a plowed field——"

"Oh, that's like your yarn of a depraved wheelman on the Great Wall of China," said Orange. "We should be proud of this road in New Jersey."

"Or in Connecticut," said Mr. Nutmeg; "we don't plane and sand-paper our roads, as they do around Boston."

"Quil always wants a calendered surface



OLD POWDER HOUSE.

to run on," ventured the Wobbler, as he pirouetted from one ridge to another.

"Yes; like Mother Ann, he founded a community of shakers," broke in Ned, as he passed them, "and he'll be left as far behind as she is unless he hastens."

A turn in the smoother road brought the laggards in sight of the advance guard waiting on Powder House

Rock, an abrupt ledge rising to a considerable height, on whose crest is a quaint little brick structure used for storing ammunition in provincial and Revolutionary times. While our Artist was sketching it, the others were taking in the pleasant view of the meandering Charles and the beautiful country village of Dedham, whose original name, Contentment, ought never to have been changed. Eastward, across the street and the intervale, they saw the end of a canal three-fourths of a mile in length, which was made in 1639, to draw water from the Charles into Mosher Brook. It is the oldest canal in the United States, and forms a connection, called

"Mill Creek," between the Charles and Neponset rivers, making an island of six towns and three cities, around which the Boston boatman has often dipped his oar.

As our battalion moved in graceful order through the pleasant streets of Ded-



PASSING A SCHOOL.

ham, by its villas and churches and Memorial Hall and business blocks, the Captain and our Highland Laddie recalled in contrast the scene of two hundred and forty-four years before, when a few pioneers from Roxbury and Watertown entered this same locality, then rich in woodlands and wolves, and "sat down together."

A little way out still stands a most picturesque old dwelling, with low lop-eaves,

"and here at their feet John Eliot learned the polysyllabic accents of the Indian maids and won the hearts of their brothers of the forest wilds by reciting in their own tongue the war-songs of David." He was aglow with enthusiasm. The ride had restored his boyhood. He hurled pebble stones high into the air until they looked like bullets in the effort to reach the top while, watch in hand, he counted the seconds of



PICNIC LUNCH.

small windows and large chimney, showing the wear and tear and moss of age, and overhung with high, overreaching trees. This "Fairbanks homestead" is said to have stood against the wild attacks of savages, wolves, storms and "modern conveniences" since 1639. Our Artist beamed with delight as he and Apollo reined up before the quaint rookery, and saw it skirted with a fringe of gleaming bicycles leaned against the rustic fence. The riders whirled away southward, however, and dismounting, walked away into a pasture in search of a group of prehistoric chestnut trees. Rugged and gnarly, with scraggy arms swung aloft and a girth of thirty feet, each particular tree seemed to mock at the centuries and to vie with its fellows in longevity.

"Massasoit and Chickatabut and their swarthy warriors have danced beneath their branches," said Champagne, while his comrades lay on their backs looking upward through the tree-tops into the blue sky;

their falling to estimate the height. It was this effervescence of good nature that had earned him his name—a sparkling, bubbling good humor and quick suggestion, a readiness for any detour or feat or fun, that from the moment he put his foot to pedal in the morning of the meet made him a most genial companion. "I love my wheel," he said, "as the yachtsman loves his boat; I enjoy the recreation it brings as my boy does his play after school, and it puts care and weariness further from me."

Returning to the old house over a fine and level roadway, Ned and Muffin indulged in a scrub race. It was injudicious in face of a long run; but when they had happened abreast, one had advanced a little, then the other, and so on, until without design the question of speed had arisen and must be settled. Muffin tightened his hold on the handles, set his elbows wing and wing, leaned well over his wheel, and put quick feet to the cranks. The full muscles of calf

and thigh waxed and waned, and like a racking Canadian horse, with his head down and forward, he rocked from side to side, as his weight changed, until he seemed a nondescript bundle of action on a runaway

“the Fairbanks homestead” again, fairly two lengths ahead of Muffin, who folded his arms behind him and unconcernedly wobbled by.

There had been a murmur of “rations” among the slower riders, and now there was a yearning inquiry to the same effect toward the front; but the finest of two mile stretches lay dinnerward over smooth undulating road to the east. The tiny valley of Mother Brook, two or three small ponds, the rural village of Hyde Park, rose one after another to view on the left; on the right were country villas and green fields, while before were the woodlands around Readville, with the western and highest of the Milton Hills rising in perspective beyond. A brisk spin, and then three short notes of the whistle called to a rest by the wayside in a grove of pines. Wheels were soon piled or leaned against the trees, and a general rest-as-you-please was effected on the soft knolls and in the breezy shadows. It was ten minutes before one by the watches—ten minutes ahead of time; but the prompt wagon of the caterer had already arrived. A long white cloth, stretched over the pine matting on the ground, was soon covered with the sundry good things which it is the caterer’s art to supply, in profusion suited to the forty-odd fresh appetites. While these things were being diminished by the wanderers, grouped in every possible position around, the horses of Apollo and Jacob, the driver, were baiting at one side, and our Artist between courses penciled at a memorandum sketch.

The conversation baffled all reporting. Wit, humor, anecdote, narrative, toasts in coffee to Colonel Bounce, who had privately paid for the picnic viands; to Apollo and our Artist, who had favored the social as well as the fine arts by accepting such escort; to the Captain, who had contrived and sprung upon his (largely) unsuspecting command the pleasures of the day—all contributed to the enjoyment of the occasion.

Any other toasts which might have been thirsting for response were prevented by the sudden summoning of a coffee-can court martial, which immediately sat on the case of Quil, the editor. He had been detailed, at his own suggestion, to proceed to Dedham, and meet Jacob and the caterer, and conduct them to the pine grove. It was alleged that he was afterward seen, far from the line of such duty, in animated conversation on a secluded piazza with a

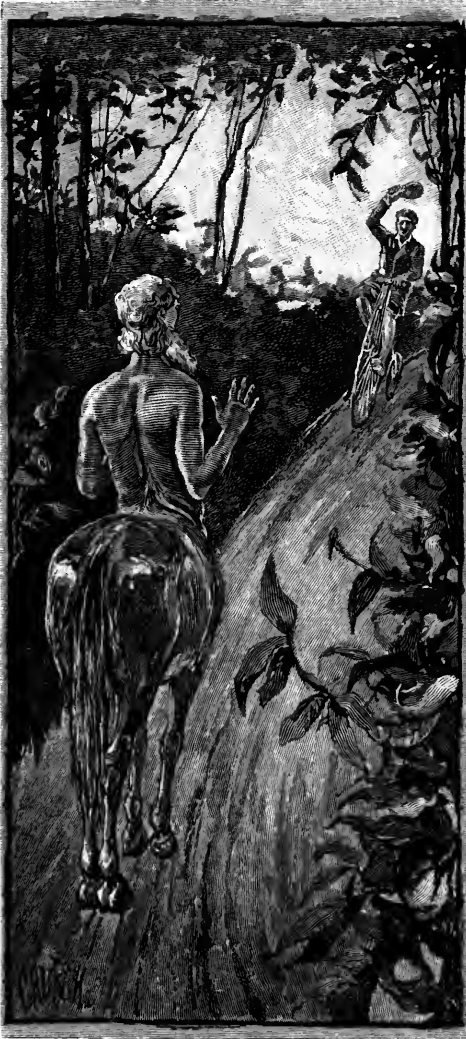

AN UNEXPECTED MEETING.

wheel. Ned, on the other hand, erect and apparently motionless above his saddle, with a graceful and steady movement, sped onward like a deer. How they flew! The wheels appeared but skeleton rims. The others increased speed to keep well in sight, now and then letting go the ebonies and clapping their hands. Half a mile, three-quarters, a mile, receded, and Ned put legs over handles and pressed on his brake, at



fair damsel, who was neither his sister nor his cousin nor his aunt; and that he arrived at the grove just in time to reverse machine, and salute his superior officer, as the company came up, with that innocent and enthusiastic assurance which so frequently adorns his otherwise well-formed face. But as the charge rested mainly on the testimony of Old Easy and the Masher, both

of whom were known to the court to be subject to hallucinations of the sentimental sort, and as the defendant did not "denige of it," he was promptly acquitted.

At precisely 2:30 the order was given to mount, and again the gallant battalion formed a line on the street, each man with his right hand on his saddle; and, at the signal of "Boots and Saddles," each in turn

SOME WINDOWS BY THE WAY

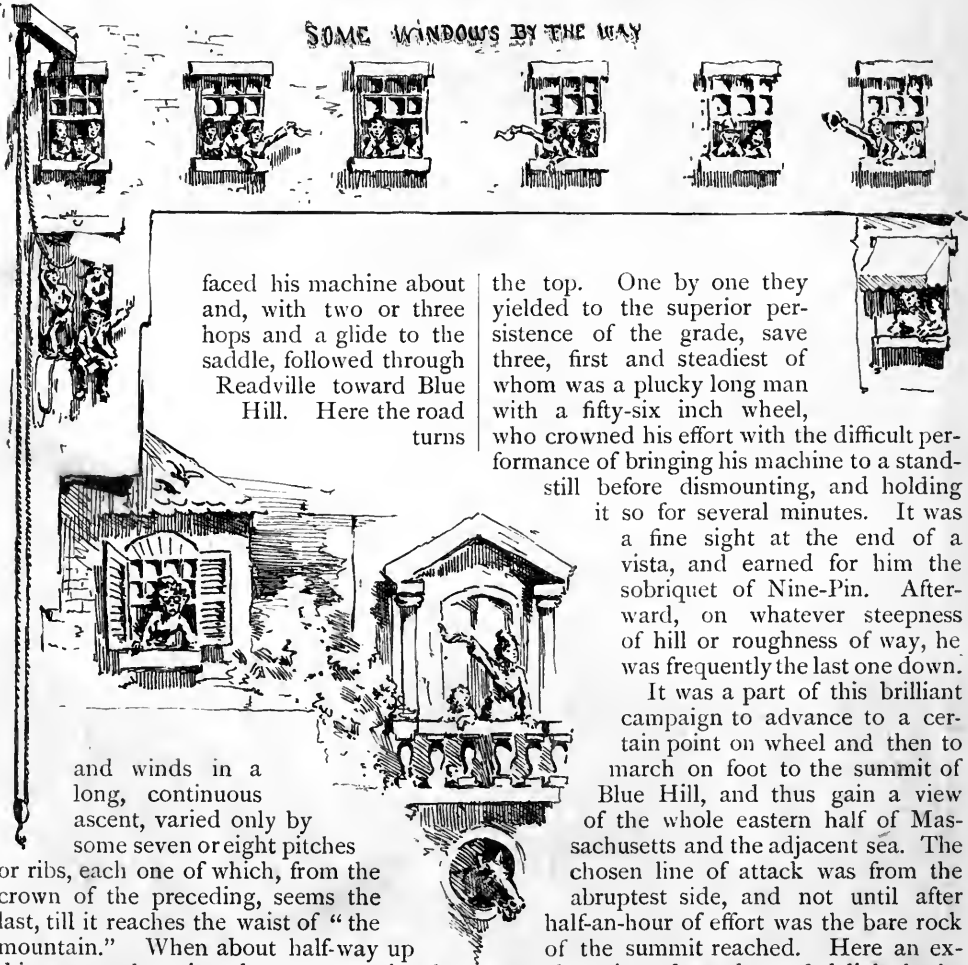

faced his machine about and, with two or three hops and a glide to the saddle, followed through Readville toward Blue Hill. Here the road turns

the top. One by one they yielded to the superior persistence of the grade, save three, first and steadiest of whom was a plucky long man with a fifty-six inch wheel, who crowned his effort with the difficult performance of bringing his machine to a standstill before dismounting, and holding it so for several minutes. It was a fine sight at the end of a vista, and earned for him the sobriquet of Nine-Pin. Afterward, on whatever steepness of hill or roughness of way, he was frequently the last one down.

and winds in a long, continuous ascent, varied only by some seven or eight pitches or ribs, each one of which, from the crown of the preceding, seems the last, till it reaches the waist of "the mountain." When about half-way up this ascent, those in advance, at a signal from the Captain, dismounted and walked beside their machines; while several of those in the rear, lured on by the delusion of the ribs, continued to ride and struggle toward

It was a part of this brilliant campaign to advance to a certain point on wheel and then to march on foot to the summit of Blue Hill, and thus gain a view of the whole eastern half of Massachusetts and the adjacent sea. The chosen line of attack was from the abruptest side, and not until after half-an-hour of effort was the bare rock of the summit reached. Here an exclamation of wonder and delight broke from all. The brown top of Wachusett, the dim and distant Kearsarge and Tom; the valleys of the Neponset and the Charles, the Concord and the Blackstone;

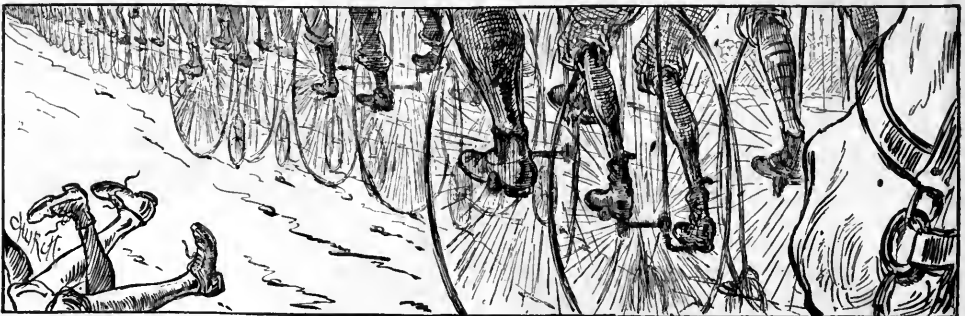

WINNERS OR LOSERS BY HALF A LENGTH.

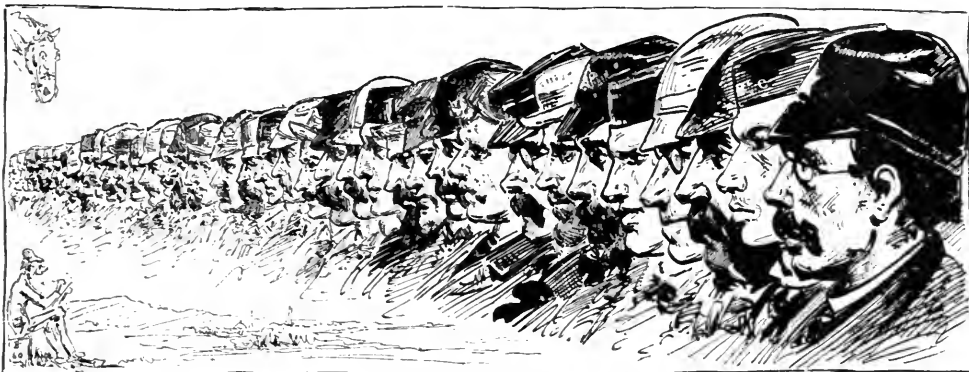

THE DRAMATIS PERSONÆ.

the silver lakes of Massapoag, Quinsigamond and Cochituate; the gilded dome of Boston, the red-roofed villas of Nahant and Swampscott, of Squantum and Nantucket; the shimmering bays and blue sea beyond; the numerous spires and villages, fertile fields and forest wild,—all these were spread out under the clear sky in panoramic view. To the south-east was “little Blue

of the gilded dome?” said the Captain. “It is the Roxbury stand-pipe, near the place of our meet; then turn and look nearly southward, beyond the spires, to Massapoag, our destination to-night; and nearly eastward, to right of Minot’s Ledge Light, is Cohasset, where we dine to-morrow.”

A speedy mount followed their descent from the “hill,” and then a brisk spin down grade

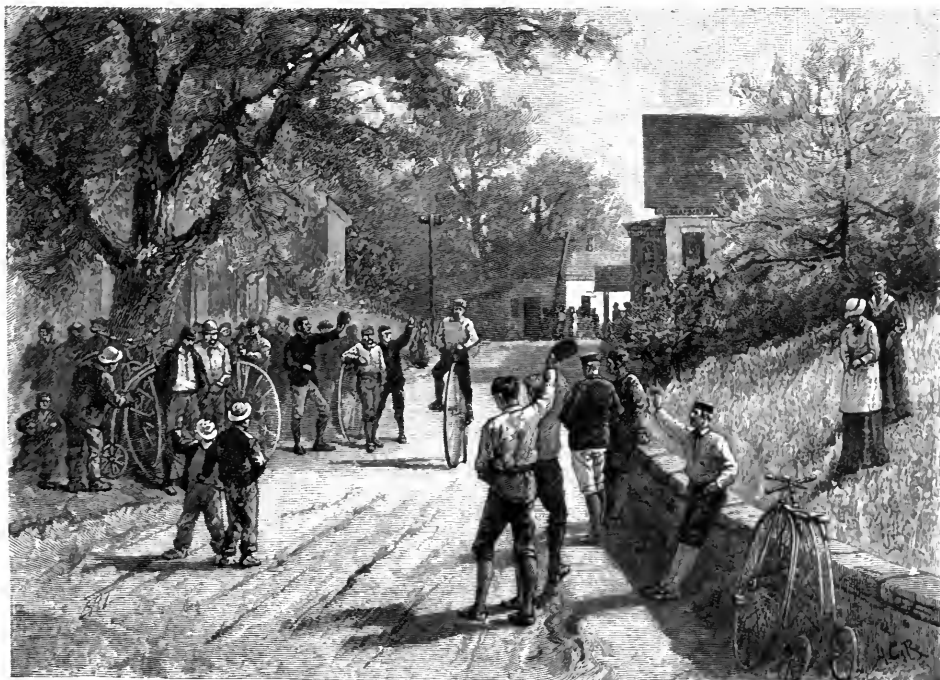

HALT TO CATCH UP.

Hill” and the long range stretching toward Mount Wollaston and the bay, while, nestled in the valley below, lay peaceful Ponkapoag.

“See that white tower a little to the left

and over gentle hills, by the trim, tasteful poet-home of Aldrich, by the well-kept farms and cemeteries and country-seats of Canton, on through the noisy, stirring village of

South Canton. Lightly sped the wheels into lovely Sharon. The evening air grew cool and the shadows lengthened as the pilgrims approached, in double file and close ranks, the eastern border of Massapoag. Here they followed the wend of the lake, and took the last mile and a half in the fading rosiness of sunset and the silvern twilight that succeeded. Smiles and waving handkerchiefs of ladies greeted them from the piazzas of the Massapoag House, as the notes of a "quickstep" signaled the approach, and the two bars of dismount followed. The cyclometers registered thirty-five miles, the baggage was brought in and

Seal brown, chestnut, gray, drab, and blue were the colors, with now and then bright stockings or silver buckles and buttons to break the soberness of hue. Wheel talk, reminiscences of runs and races, the scenes and incidents of the day, furnished material for parlor conversation. There was a humorous address by the Arab on the "Unnatural History of the Oyster." In songs, the Tenor was at his best, well supported by the strong bass of the Colonel, the rich baritone of Shenstone, and by other voices, especially in the choruses. When the bicycling song, written by our Highland Laddie, was rendered to the air of "Dear-

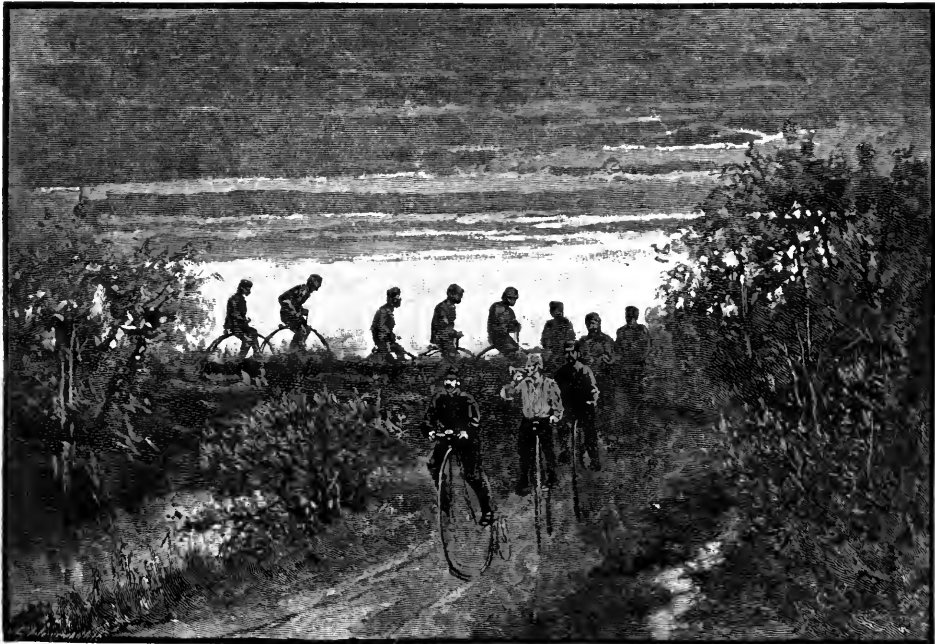

EN SILHOUETTE.

the hungry guests registered and sought their appointed rooms. There was luxury in sponge and towel and fresh merinoes, and no lack of good cheer and brilliant conversation at the two long tables. The hotel had unconditionally surrendered.

In the parlors the costumes of the wheelmen seemed not so much out of place as they were pleasing in their variety and color, while the uniformity of type and a certain positiveness of style bestowed upon the wearers collectively a half military effect. Short cut-away coats over flannel shirts, white collars and black ties, knee-breeches, long-worsted stockings and low shoes, had been dusted and freshened after the ride.

est Mac," the applause was prolonged and persistent. "Farewell, Ladies!" was the closing piece of minstrelsy; and when the Masher's voice was missed, he was discovered in the opposite corner from the piano in a very engaging *tête-à-tête* with a charming young lady. This was the fifth he had won already. When, however, the music struck up, and whirling couples sought the electric floor, and the Masher in his winning way asked the young lady for the pleasure, etc., she was overheard to say, sweetly, "Thank you,—for the next; but I am always engaged to dance first with my husband." In the scenes that ensued fifteen of the bicyclers found partners.

The rest of that night! The luxury of repose after action, of sleep after a day of sunshine and fresh air and energetic but unexhausted activity of every muscle and sense and faculty! The dreamless pillow, the downiness of perfect slumber, was found; and the curtain fell on the first day of the run.

The reader has now, it is hoped, some acquaintance with our excursionists and their methods, and has caught a little of the spirit, the breeze, and "go" of the trip. The second part was twice as long in miles and equally full in interest; but the pen must skip rapidly over it, as the wheels did, and the reader's imagination must now supply much of the filling.

A cheery breakfast at six, a hasty dusting and oiling of the trusty steeds, and then a fresher start was effected than on the morning before. A gentle west wind ruffled the placid and buoyant waters of iron-bedded Massapoag, and fanned the more buoyant spirits of the forty-odd bicyclers, as they sped along its shore and quickly left it behind. Cruikshank, making a sudden spurt on a treacherous bit of road, broke an axle, and was the first victim of the ambulance. A hasty good-by was said to him under the elms, at South Canton, whence he sadly turned away for a steam-train home. The lead was now for three or four miles over a devious country road, nearly all through woodlands, often loose or rutted, with occasional sand, and two or three sharp hills: a romantic route, but of a character to tax what might well be called the *horsemanship* of bicycling. Only the more experienced



PAN-DOWDY.

rode it all without enforced dismounts.

Then came Baptist Corners, in view of the fine old

village of Randolph, and a few miles further on through an undulating country, the beautiful village of South Braintree, built lovingly around a smiling natural pond, and in view of the quarry-end of the Milton hills, with its forest of derricks. Here it became evident that the inquisitive reporter of yesterday had published the "programme," and the people were expecting the comers. Carriages drove out to meet them and escort



them into the town; and the reception was all the pleasanter because they were "on time."

Every one along the route through Braintree and Weymouth seemed on the watch; factory windows were filled with faces, men had climbed the roofs, and boys the trees; and when, for instance, Shenstone and Quinsigamond came sailing down an easy grade side by side, one with legs over

Colonel, he had been off on a railway trip for a fortnight, night and day, and had ridden little during the season. At Hingham there was a smell of sea air; and when, after a brief halt for rations, the Captain waved his hand, and ordered "all aboard for Cohasset;" the scarcely cooled saddles were again taken, and the company made the next five miles toward a fish dinner by the sea in twenty-five minutes.

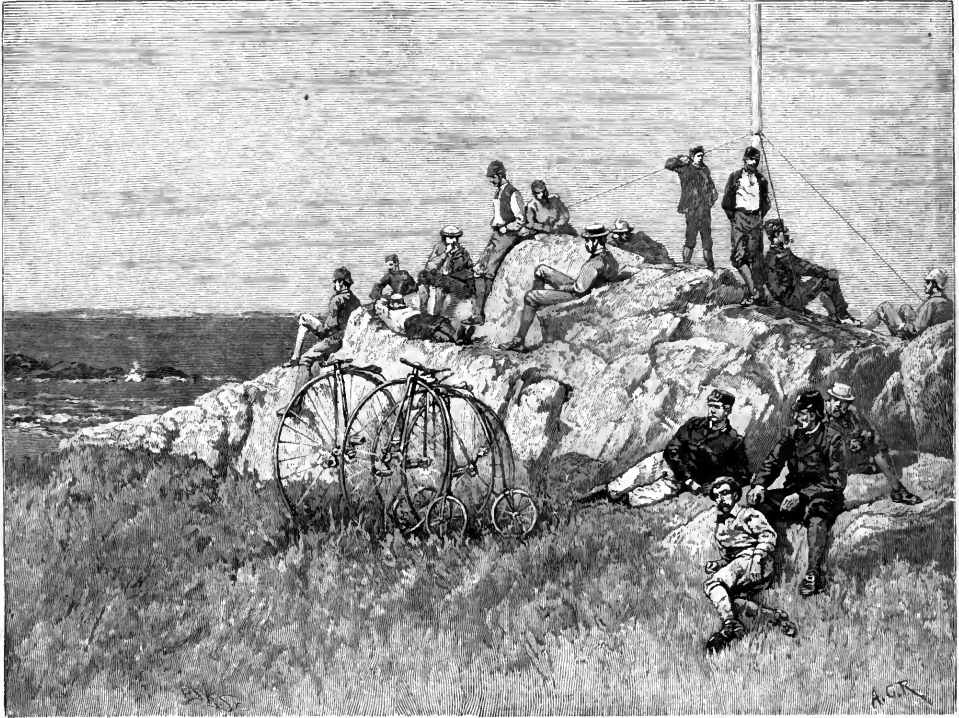

ON THE ROCKS AT COHASSET.

handles, and the other with feet up on the toe-rests, or when Ned and the Tenor rode abreast in a span joining hands, they were greeted with applause from the crowds; and then some little boy, seated on a curbstone, would shout the familiar chorus: "'Hoa Wemmer!" as the rapid wheels went by. When, however, the rear was brought up by Jacob's ambulance, with Quil and the fat Colonel, and their machines thereon, the populace, supposing the run to be a race, was too much excited not to visit them with many adverse greetings—"Oh, you're playin' it on em!" "It's no fair!" "Get off o' that!" "You're cheatin'!" "He's too fat!" "They've given it up!" Quil said afterward that a flaw in his socket-head threatened him with disaster; and as for the

Not one of the well-trimmed yachts off Cohasset was in finer form than the jolly bicyclers as they luffed up and took their moorings at Kimball's fine old establishment, far out on the bluff rocks looking oceanward. The cyclometers read thirty-two miles since breakfast. It was not yet one o'clock. Apollo and Jacob had taken fresh horses at Hingham; "They are the two best horses in Roxbury," said Jacob, "but they can't follow them new-fangled velocipedes any further without a three hours' rest, anyhow." Bounce and Nutmeg had stopped at Hingham, with Quil and two or three others, to take a train for Boston; but the faithful thirty-two paused between courses to nibble their celery and congratulate themselves on the happy point just made, and

began to talk briskly of the home stretch, thirty miles toward sunset.

"Apple-pie, squash-pie, and pan-dowdy," said a pretty and innocently pert maiden, to whom more trifling remarks had been made than were necessary to the detail of dining.

"What is pan-dowdy?" asked Orange.

"It's part of the dessert, sir, and it's nice to-day," answered the maiden.

"If she says it's nice, it must be," said Orange, feigning to speak under his breath. When it was brought in he looked at the plate, heaped with something very like pudding, and asked, quizzically, "But where is the pan-dowdy?"

"The pan is in the kitchen," replied the maiden, and with an arch look directly at her victim, "*here* is the dowdy!"

Laughter shook the table, and Orange stood treat. Our Artist had scarcely traced a sketch of the pretty profile, when his eye was again caught by the after-dinner grouping of the party on the most prominent and picturesque of the rocks which stood between the lawn and the tides. Apollo and the Captain here recalled the beautiful story of Thorwald, and tried to settle in their minds the question of locality where, wounded by an arrow of the "Skraellings," he "died, and they buried him on the pleasant cape that looked out upon the pleasant shores and waters of Massachusetts Bay."

A brisk spin was made back to Hingham, where the "oldest church" was seen, and the fine Andrew Monument on the cemetery slope. Twelve miles an hour was kept up through North Weymouth and Quincy; and, with few halts, to the end of the route. The advance into the fine old village of

Quincy was greeted with ringing of school-house bells, and fire-engine alarms, and other demonstrations. The quaint and unpretentious homes of the second and sixth Presidents of the United States; Mount Wollaston, now garlanded with cottages; the oldest railway, leading from the Neponset into the rocky heart of the hills, too old for the excursionists to remember when the ox-power of 1826 gave way to the steam locomotive; the quiet attractiveness of the "Blue Bell," with its suggestion of tea and toast; the "oldest house," from whose window Mrs. Minot shot prowling Indians in 1631;—these and more were visited or passed by these pilgrims of the merriest two days' companionship and the richest hundred mile round trip of the season.

As they passed from Brookline into Brighton, the lingering rays of a setting sun held dalliance with the twilight over valley and hill. The dispersion had been gradual, and the last hour of the run was as informal as the meet. When the long ascent of Milton Hill, from the eastward, had been accomplished at a scarcely abated speed, and the magnificent view of Boston's island-spangled harbor and her matchless suburbs lay stretching in serene enchantment below, the climax of the Captain's successful campaign was reached.

The bugler sounded "Boots and Saddles," and as the last of the party whirled away, the words of our Highland Laddie's song rang clear and hearty on the evening air,—

"The sun lay crimson in the west,
The soft breeze fanned my brow,
I rode the steed I loved the best,—
Would I were riding now!"

* * * * *

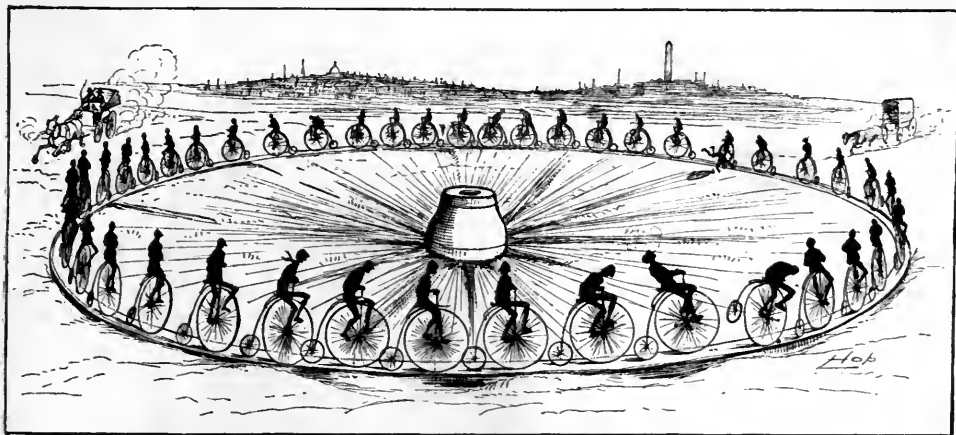

A WHEEL AROUND THE HUB.

BOOZY LITTLE BAT

+ + + + +
 BAT, LITTLE BAT
 UP THE CHIMNEY
 THERE, WHAT ARE
 YOU AT?
 NOW THAT THE
 CHRISTMAS
 CLOUDS IN
 THE SKY
 RATTLE
 WITH
 *



*
 SNOW
 FLAKES
 WARM A
 ND DRY,
 WRAPPED
 IN YOUR SOFT
 LEATHER WIN
 GS. *
 ARE YOU HOOKED
 UP THERE BY THE
 TOES? *
 DO YOU DOZE
 LIKE TOMMY THE CAT
 WHO SINGS
 * BY THE FENDER A BA
 SS TO THE KETTLE?
 SEE HIM HANG HIS HEAD
 OVER
 THE SETTLE
 QUITE UPSIDE DOWN- *
 YOU WOULD THINK HIM DONE BROW
 *
 YET HE'S IN THE FINEST OF FETTLE! +

BAT, LITTLE BAT,
 WHEREVER YOU ARE, YOU'VE A BRICK IN YOUR
 DON'T DENY IT! HAT
 HOW ELSE, WINTERS THROUGH,
 COULD YOU HANG IN A FIVE *
 SO QUIET, SO QUIET *
 HEAD DOWNWARD? JUST ANSWER ME THAT, LIT-
 TLE BAT!

OH, THE SECRET WAS TOLD ME!
 A GRAB-PATED GOBLIN (NO MATTER
 WHAT NAME! SMALL BATS MUSTN'T CHATTER)
 HAS BLABBED, LITTLE BAT, *
 OF THE BRICK IN YOUR HAT *
 EVERY AUTUMN—HUSH, HUSH NOW, DON'T SCOLD
 FOR HE SAID, ON THE GREEN ME!
 WHERE TITANIA, THE QUEEN
 OF FAIRYLAND HELD HARVEST REVEL,
 YOU WERE SEEN *
 AFTER DAWN *
 WHEN THE FAIRIES WERE GONE—
 FIE! DRINKING THE DREGS OF THE NECTAR POT-
 THEEN!

OH! OH! WHO'D HAVE THOUGHT
 YOU, BATLET, A SOT
 WHO DWELL ON SO LOFTY A LEVEL!
 TEHEE, LITTLE BAT, *
 SO WE FIND IT IS THAT *
 MAKES YOU SNOOZE WITHOUT CARE
 WITH YOUR HEELS IN THE AIR
 THOUGH THE DRAUGHT BE TREMENDOUS AND
 EVER SO HOT!

BUT IT'S NEVER TOO LATE;
 NEXT YEAR, WHEN YOU MATE *
 AND YOUR CHILDREN ARE FLEDGE, *
 COME DOWN TO OUR FIRE
 SMALL BROWN-COATED FRIAR
 AND SIGN, LIKE A GOOD FATHER, MATTHEW,
 THE TEMPERANCE PLEDGE.



NEW ENGLAND FENCES.

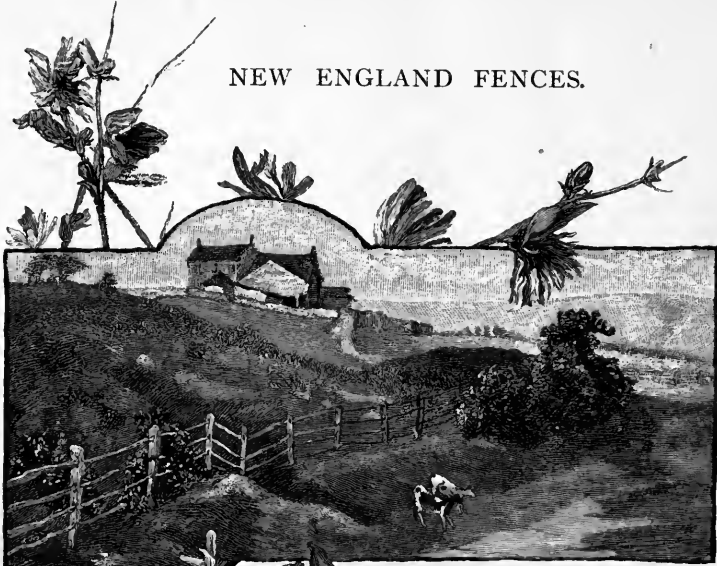

POST AND RAIL FENCE.

A QUESTION of the future, that troubles the mind of the farmer more

than almost any other is, What are we to do for fences? The wood-hungry iron horse is eating away the forests greedily and rapidly, and our people are ready to feed him to his fill for a paltry present fee, apparently learning no wisdom from the follies of our forest-destroying ancestors, but carrying on the same old, senseless, and indiscriminate warfare against trees wherever found, and seldom planting any except fruit-trees and a few shade-trees.

And, alas! no just retribution seems to overtake these evil-doers, except that most speculating deforesters go to the bad peculiarly, but the curse descends on the sorrowing lovers of trees, and will fall on our children and our children's children,—the curse of a withered and wasted land, of hills made barren, of dried-up springs and shrunken streams.

It seems probable that a generation not far removed from this will see the last of

the rail fences, those time-honored barriers of New England fields, too generous of timber to be kept up in a land barren of forests. The board fence will endure longer, but will pass away at last, and after it, what? Where stone walls are, they may continue to be, and where there are stones enough there may be more stone walls, but all New England is not so bountifully supplied in this respect as parts of it that I have heard of, where if one buys an acre of land, he must buy another to pile the stones of the first acre on. In some of our alluvial lands it is hard to find stones enough for the corner supports of rail fences. The hedge, except for ornamentation in a small way, does not, somehow, seem to take kindly to us, or we to it; at least, I have never seen one of any great length, nor one flourishing much, that was intended to be a barrier against stock. If ever so thrifty for a while, is it not likely that the pestiferous field-mice, which are becoming plentier every year, as their enemies, the foxes, skunks, hawks, owls and crows grow fewer, would destroy them in the first winter of deep snow? Great hopes were entertained of the wire fence at one time, but it has proved to be a delusion and indeed a snare. Some are temporizing with fate, or barely surrendering, by taking away the fences where grain fields or meadows border the highway. To me it is not

pleasant to have the ancient boundaries of the road removed, over which kindly-spared trees have so long stood guard, and along whose sides black-raspberry bushes have sprung up and looped their inverted festoons of wine-colored stems and green leaves with silver linings, bearing racemes of fruit that the sauntering school-boy lingers to gather. And far from pleasant is it to drive cattle or sheep along such unfenced

stared a little at first at Ridgeway's Ready Restorative, but never took any.

However, it is not my purpose to speculate concerning the fences of the future, nor to devise means for impounding the fields of posterity, but rather to make some record of such fences as we now have, and some that have already passed away.

The old settlers, when they had brought a patch of the earth face to face with the



BRUSH FENCE.

ways, which they are certain to stray from, and exhaust the breath and patience of him who drives them and endeavors to keep them within the unmarked bounds; moreover, it gives the country a common look in more than one sense, as if nothing were worth keeping in or out. It will be a sad day for the advertiser of patent nostrums, when the road fence of broad, brush-inviting boards ceases to exist, and if we did not know that his evil genius would be certain to devise some blazoning of his balms, liniments, and bitters, quite as odious as this, we should be almost ready to say, away with this temptation. That was a happy device of one of our farmers, who turned the tables on the impudent advertiser, by knocking the boards off and then nailing them on again with the letters facing the field. The cattle

sun, and had sown their scanty seed therein, fenced it about with poles, a flimsy-looking barricade in the shadow of the lofty palisade of ancient trees that walled the "betterments," but sufficient to keep the few wood-ranging cattle out of the field whose green of springing grain was dotted and blotched with blackened stumps and log-heaps. The pole fence was laid after the same fashion of a rail fence, only the poles were longer than rail-cuts. There were also cross-staked pole fences, in which the fence was laid straight, each pole being upheld by two stakes crossing the one beneath, their lower ends being driven into the ground. This and the brush fence, though the earliest of our fences, have not yet passed away. That the last has not, one may find to his sorrow, when, coming to its lengthwise-laid abatis in the

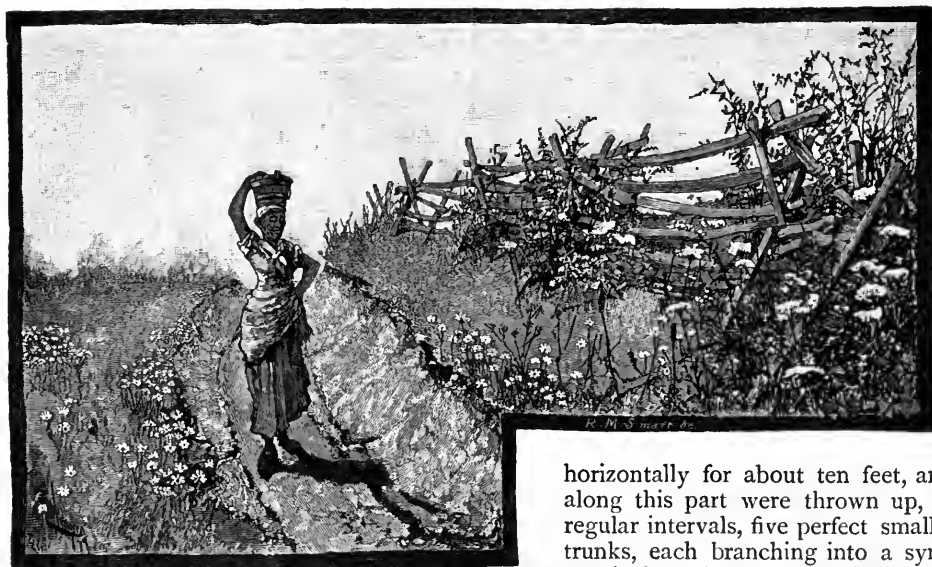

SNAKE OR VIRGINIA FENCE.

woodland, he attempts to cross it. If he achieve it with a whole skin and unrent garments, he is a fortunate man, and if with an unruffled temper, he is certainly a good-natured one. According to an unwritten law, it is said that a lawful brush fence must be a rod wide, with no specification as to its height. You will think a less width enough, when you have made the passage of one. Coming to it, you are likely to start from its shelter a hare who has made his form there; or a ruffed grouse hurtles away from beside it, where she has been dusting her feathers in the powdery remains of an old log; or you may catch glimpses of a brown wood wren silently exploring the maze of prostrate branches. These are the fence viewers of the wood lot.

To build or pile a brush fence, such small trees as stand along its line are lopped down, but not severed from the stump, and made to fall lengthwise of the fence; enough more trees are brought to it to give it the width and height required. Many of the lopped ones live and, their wounds healing, they grow to be vigorous trees, their fantastic forms marking the course of the old brush fence long after it has passed from the memory of man. I remember a noted one which stood by the roadside till an ambitious owner of a city lot bought it and had it removed to his urban patch, where it soon died. It was a lusty white oak, a foot or so in diameter at the ground, three feet above which the main trunk turned at a right angle and grew

horizontally for about ten feet, and along this part were thrown up, at regular intervals, five perfect smaller trunks, each branching into a symmetrical head. It was the finest tree of such a strange growth that I ever saw, and if it had grown in a congenial human atmosphere, doubtless would have flourished for a hundred years or more, and likely enough, have become world-renowned. It was sold for five dollars! No wonder it died!

The log fence was a structure of more substance than either the pole or the brush fence, but belonged to the same period of plentifulness, even cumbersomeness, of timber. The great logs, generally pine, were laid straight, overlapping a little at the ends, on which were placed horizontally the short cross-pieces, which upheld the logs next above. These fences were usually built three logs high and formed a very solid wooden wall, but at a lavish expense of material, for one of the logs sawn into boards would have fenced several times the length of the three. I remember but one, or rather the remains of one, for it was only a reddish and gray line of moldering logs when I first knew it, with here and there a sturdy trunk still bravely holding out against decay, gray with the weather beating of fifty years, and adorned with a coral-like moss bearing scarlet spores.

From behind the log and brush fences, the prowling Indian ambushed the backwoodsman as he tilled his field, or reconnoitered the lonely cabin before he fell upon its defenseless inmates. Through or over these old-time fences, the bear pushed or clambered to his feast of "corn in the milk" or perhaps to his death, if he blun-

dered against a harmless-looking bark string and pulled the trigger of a spring-gun, whose heavy charge of ball and buck-shot put an end to his predatory career.

After these early fences came the rail fence, as it is known in New England, or the snake fence, as it is sometimes called from the slight resemblance of its zig-zag line to the course of a serpent, or the Virginia fence, perhaps because the Old Dominion was the mother of it as of presidents, but more likely for no better reason than that the common deer is named the Virginia deer, or that no end of quadrupeds and birds and plants, having their home as much in the United States as in the British Provinces, bear the title of *Cana-*

sheen of a whole fence of such freshly riven material. Some one has called the rail fence ugly or hideous. Truly, it must be confessed, the newly laid rail fence is not a thing of beauty, any more than is any other new thing that is fashioned by man and intended to stand out-of-doors. The most tastefully modeled house looks out of place in the landscape till it has gained the perfect fellowship of its natural surroundings. has steeped itself in sunshine and storm, and became saturated with nature, is weather-stained, and has flecks of moss and lichen on its shingles and its underpinning, and can stand not altogether shamefaced in the presence of the old trees and world-old rocks and earth about it. So our fence

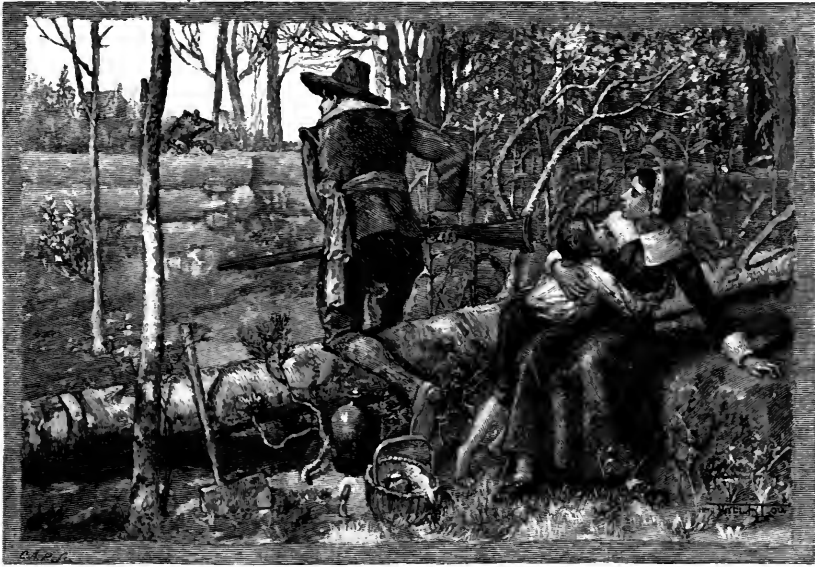

LOG FENCE.

densis. But rail, snake or Virginia, at any rate it is truly American, and probably has enclosed and does yet enclose more acres of our land than any other fence. But one seldom sees nowadays a new rail fence, or rather a fence of new rails, and we shall never have another wise and kindly rail-splitter to rule over us; and no more new pine rails, shining like gold in the sun, and spicing the air with their terebinthine perfume. The noble pine has become too rare and valuable to be put to such base use. One may catch the white gleam of a new ash rail, or short-lived bass-wood, among the gray of the original fence, a patch of new stuff in the old garment, but not often the

must have settled to its place, its bottom rails have become almost one with the earth and all its others, its stakes and caps cemented together with mosses and entwined with vines, and so weather-beaten and crated with lichens that not a sliver can be taken from it and not be missed. Then is it beautiful, and looks as much a part of nature as the trees that shadow it, and the berry bushes and weeds that grow along it, and the stones that were pitched into its corners thirty years ago, to be gotten out of the way. Then the chipmunk takes the hollow rails for his house and stores his food therein, robins build their nests in the jutting corners and the wary crow is not

afraid to light on it. What sheltering arms half inclose its angles, where storm-blown autumn leaves find their rest, and molder to the dust of earth, covering the seeds of berries that the birds have dropped there—seeds which quicken and grow and border the fence with a thicket of berry bushes. Seeds of maples and birch and basswood, driven here by the winds of winters long past, have lodged and sprouted, and have been

to complete it. Then they are so easy to climb and so pleasant to sit upon, when there is a flat top-rail; and when a bird's nest is found, it can be looked into so easily; and it is such jolly fun to chase a red squirrel and see him go tacking along the top rails; and there are such chances for berry-picking beside it. In winter, there are no snow-drifts so good to play on as those that form in regular waves along the rail fence, their crests

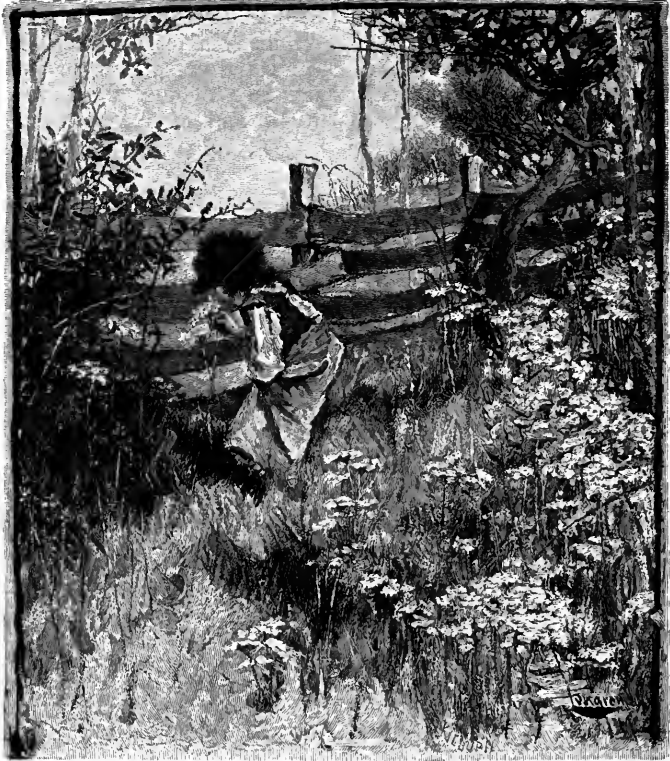

BOARD FENCE.

kindly nursed till they have grown from tender shoots to storm-defying trees; there are clumps of sumacs also, with their fuzzy twigs and fern-like leaves and "bobs" of dusky crimson. Here violets bloom, and wind-flowers toss on their slender stems in the breath of May; and in summer the pink spikes of the willow herb overtop the upper rails, and the mass of the golden rod's bloom lies like a drift of gold along the edge of the field.

The children who have not had a rail fence to play beside have been deprived of one abundant source of happiness, for every corner is a play-house, only needing a roof, which half a dozen bits of board will furnish,

running at right angles from the out-corners, their troughs from the inner ones. I am sorry for those children of the future who will have no rail fences to play about.

The board fence is quite as ugly as the rail fence when new, perhaps more so, for it is more prim and more glaring, as there is no alternation of light and shade in its straight line. But age improves its appearance also, and when the kindly touch of nature has been laid upon it, and has slanted a post here and warped a board there, and given it her weather-mark, and sealed it with her broad seal of gray-green and black lichens, by which time weeds and bushes have grown in its shelter, it is very picturesque. Its pre-

vailing gray has a multitude of shades; the varied weather-stains of the wood, the lichens, the shags of moss and their shadows, and some touches of more decided color, as the yellowish-green mold that gathers on

The fence which is half wall and half board has a homely, rural look, as has the low wall topped with rails, resting on cross-stakes slanted athwart the wall, or the ends resting in rough mortises cut in posts that

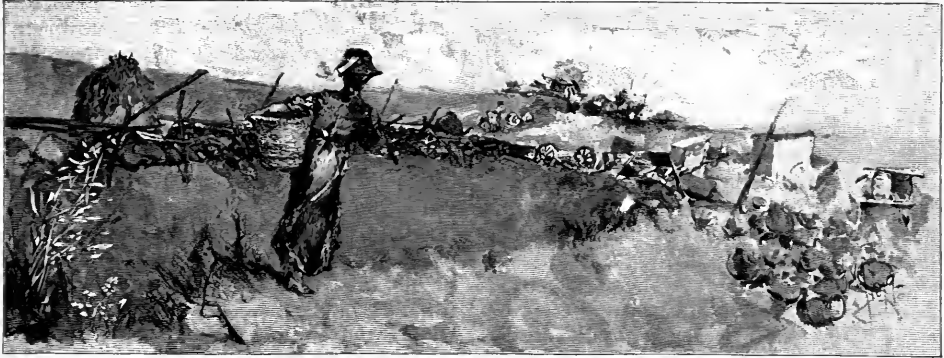

OLD HALF-WALL FENCE.

some of the boards, the brown knots and rust-streaks from nail-heads, patches of green moss on the tops of posts, and here and there the half—or less—of a circle, chafed by a swaying weed or branch to the color of the unstained wood.

The wood-pecker drills the decaying posts, and blue-bird and wren make their nests in the hollow ones. There is often a ditch beside it, in which cowslips grow, and cat-tails and pussy-willows, akin only in name; on its edge horse-tails and wild grass, and higher up on the bank a tangle of hazel, wild mulberry, gooseberry and raspberry bushes, with a lesser undergrowth of ferns and poison ivy. The field and song sparrows hide their nests in its slope, and if the ditch is constantly and sufficiently supplied with water, sometimes the musk-rat burrows there, and you may see his clumsy tracks in the mud and the cleanly cut bits of the wild grass roots he has fed upon. Here, too, the hylas holds his earliest spring concerts.

All this applies only to the plain, unpretending fence, built simply for the division of fields, without any attempt at ornament. Nature has as slow and painful a labor to bring to her companionship the painted crib that encloses the skimpy door-yard of a staring, white, new—or modernized—farm-house, as she has to subdue the glare of the house itself; but she will accomplish it in her own good time,—the sooner if aided by a little wholesome unthrift of an owner who allows his paint-brushes to dry in their pots.

are built into the wall, which is as much of a "post and rail" fence as we often find in northern New England. A new fence of either kind is rarely seen nowadays in our part of the country, and both may be classed among those which are passing away.

Of all fences, the most enduring and the most satisfying to the eye is the stone wall. If its foundation is well laid, it may last as long as the world,—which, indeed, it may slowly sink into; or the accumulating layers of earth may in years cover it; but it will still be a wall—a grassy ridge with a core of stone. A wall soon gets rid of its new look. It is not propped up on the earth, but has its foundations in it; mosses and lichens take quickly and kindly to it, and grass and weeds grow out of its lower crevices, mullein and brakes and the bulby stalks of golden-rod spring up beside it. Black raspberry bushes loop along it, over it, and stretch out from it, clumps of sweet elders shade its sides, and their broad cymes of blossoms, and later, clusters of blackberries, beloved of robins and school-boys, bend over it. When the stones of which it is built are gathered from the fields, as they generally are, they are of infinite variety, brought from the far north by glaciers, washed up by the waves of ancient seas, and tumbled down to the lower lands from the overhanging ledges. Lumps of gray granite and gneiss, and dull-red blocks of sandstone, fragments of blue limestone, and only a geologist knows how many others, mostly with smooth-worn sides and rounded corners and edges. All together, they make a line of beautifully varie-

gated color and of light and shade. One old wall that I know of has been a rich mine for a brood of callow geologists, who have pecked it and overhauled it and looked and talked most wisely over its stones, and called them names hard enough to break their stony hearts.

At the building of the wall, what bending and straining of stalwart backs and muscles; what shouting to oxen—for it would seem the ox can be driven only by sheer strength of lungs; what rude engineering to span the rivulet; what roaring of blasts, when stones were too large to be moved in whole, and the boys had the noise and smoke and excitement of a Fourth-of-July celebration without a penny's expense, but alas! with no gingerbread nor spruce beer. Then, too, what republics were convulsed when the great stones, underneath which a multitude of ants had founded their commonwealth, were pried up, and what hermits were disturbed when the newts were made to face the daylight, and earwigs and beetles forced to scurry away to new hiding-places! But when the wall was fairly built, the commonwealths and hermitages were re-established beneath it, more secure and undisturbed than ever.

make a breach in his stronghold through which the dogs can reach him, or throw him a "slip-a-noose" into which he hooks his long teeth and is hauled forth to death. The weasel frequents a wall of this kind, and there is hardly a fissure in its whole length through which his lithe, snake-like body cannot pass. You may now perhaps see his eyes peering out of a hole in the wall, so bright you might mistake them for dew-drops on a spider's web, or see him stealing to his lair with a field mouse in his mouth. In spring, summer and fall, nature clothes this little hunter in russet, but in winter he has a furry coat almost as white as snow, with only a black tip to his tail by which to know himself in the wintry waste. The chipmunk, too, haunts the wall, and the red squirrel finds in it handy hiding-places into which to retreat, when from the topmost stone he has jeered and snickered at the passer-by beyond all patience.

Long after our people had begun to tire of mowing and plowing about the great pine stumps, whose pitchy roots nothing but fire would destroy, and when the land had become too valuable to be lumbered by them, some timely genius arose and invented the stump puller and the stump fence. This fence with-

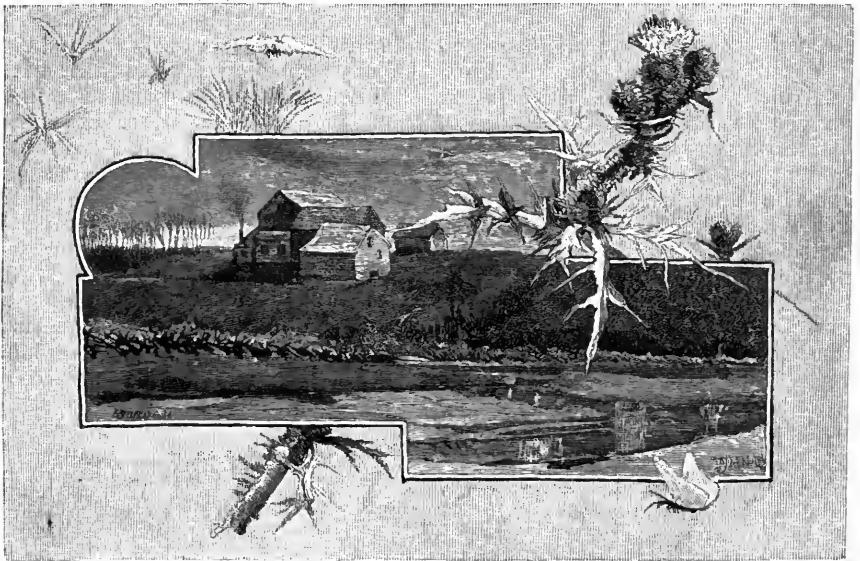

OVER THE STUMP FENCE.

The woodchuck takes the stone wall for his castle, and through its loopholes whistles defiance to the dogs who besiege him, but woe be to him if the boys join in the assault. They

stands the tooth of time as long as the red-cedar posts, of which the boy said he knew they would last a hundred years, for his father had tried 'em lots of times; and now many

fields of our old pine-bearing lands are bounded by these stumps, like barricades of mighty antlers. These old roots have a hold on the past, for in their day they have spread themselves in the unsunned mold of the primeval forest, whereon no man trod but the wild Abnaki, nor any tamed thing; have had in turn for their owners swarthy sagamores, sceptred kings and rude backwoodsmen. Would they had life enough left in them to tell their story!

There is variety enough in the writhed and fantastic forms of the roots, but they are slow to don any covering of moss and lichens over their whity-gray, and so they have a bald, almost skeleton-like appearance. But when creeping plants—the woodbine, the wild grape and the clematis—grow over the stump fence, it is very beautiful. The woodbine suits it best, and in summer converts it into a wall of dark green, in autumn into one of crimson, and in winter drapes it gracefully with its slender vines.

This fence has plenty of nooks for berry bushes, milk-weeds, golden rods and asters to grow in, which they speedily do and, as a return, help to hide its nakedness. Nor does it lack tenants, for the robin builds on it, and the blue-bird makes its nest in its hollow prongs, as the wrens used to, before they so unaccountably deserted us. The chipmunk finds snug cells in the stumps, woodchucks and skunks burrow beneath it, and it harbors multitudes of field mice.

In the neighborhood of saw-mills, fencing a bit of the road and the sawyer's garden patch, but seldom elsewhere, is seen a fence made of slabs from the mill, one end of each slab resting on the ground, the other upheld by cross stakes. It is not an enduring fence, and always looks too new to be as picturesque in color as it is in form. The common name of this fence is quite suggestive of the perils that threaten whoever tries to clamber over it, and he who has tried it once will skirt it a furlong rather than try it again. The sawyer's melons and apples would be safe enough inside it if there were no boys,—but what fence is boy-proof?



Sawyers fences

NO
*
T
M
O
R
O
W
U
G
M
F
A
R
E



SAWYER'S FENCE.

Of all fences, none is so simple as the water fence, only a pole spanning the stream, perhaps fastened at the larger end by a stout link and staple to a great water-maple, ash or buttonwood-tree, a mooring to hold it from going adrift when the floods sweep down. If the stream is shallow, it has a central support, a big stone that happens to be in the right place, or lacking

this, a pier made like a great bench; if deep, the middle of the pole sags into the water and the upper current ripples over it. On it the turtle basks; here the wood-duck sits and sleeps or preens his handsome feathers in the sun, and the kingfisher watches

the same chance getting perhaps as many as they lose.

I have seen a very peculiar fence in the slate region of Vermont, made of slabs of slate, set in the earth like a continuous row of closely planted headstones. It might



A WATER FENCE.

for his fare of minnows, and the lithe mink and the clumsy muskrat rest upon it. Neighbors' cattle bathe in and sip the common stream, and lazily fight their common enemies, the fly and the musquito, and for all we know compare the merits of their owners and respective pastures.

The fences of interval lands cannot be called water fences, although during spring and fall freshets they divide only wastes of water, across which they show merely as streaks of gray, or, as they are too apt to do, go drifting piecemeal down stream with the strong current. Then the owners go cruising over the flooded fields in quest of their rails and boards, finding some stranded on shores a long way from their proper place, some lodged in the lower branches and crotches of trees and in thickets of button-bushes, and some afloat,—losing many that go to the gain of some riparian freeholder further down the stream, but by

give a nervous person a shudder, as if the stones were waiting for him to lie down in their lee for the final, inevitable sleep, with nothing left to be done but the stone-cutter to come and lie on the other side the fence.

The least of fences, excepting the toy fences that impound the make-believe herds of country children, are the little pickets of slivers that guard the melon and cucumber hills from the claws of chanticleer and partlet. These are as certain signs of the sure establishment of spring as the cry of the upland plover. They maintain their post until early summer, when, if they have held their own against bugs, the vines have grown strong enough to take care of themselves, and begin to wander, and the yellow blossoms meet the bumble-bee half way.

The "line fence," of whatever material,

may generally be known by the trees left growing along it, living landmarks, safer to be trusted than stones and dead wood, and showing that, as little as our people value trees, they have more faith in them than in each other. The burning and fall of the "corner hemlock," on which was carved in 1762 the numbers of four lots, brought dismay to four land-owners. The old corner has lost its mooring, and has drifted a rod or two away.

What heart-burnings and contentions have there not been concerning line fences, feuds lasting through generations, engendered by their divergence a few feet to the right or left, or by the question as to whom belonged the keeping up of this part or that! When the heads of some rural households were at pitchforks' points, a son and daughter were like enough to fall into the old way, namely, love, and Juliet Brown steals forth in the moonlight to meet Romeo Jones, and they bill and coo across the parents' bone of contention, in the shadow of the guardian trees. If I were to write the story of their love, it should turn at length into smooth courses, and have no sorrowful ending—no departure of the lover, nor pining away of the lass, but at last their bridal bells should say:

"Life is sweeter, love is dearer,
For the trial and delay;"

and the two farms should become one, and nothing remain of the old fence but the trees where the lovers met, and under which their children and their children's children should play.

The ways through and over our fences are few and simple. The bar-way (in Yankee-land "a pair of bars") seems to belong to the stone wall, rail and stump fences; though the balanced gate, with its long top bar pivoted on a post and loaded with a big stone at one end, the other dropping into a notch in the other post for a fastening, is often used to bar the roadways through them. The more pretending board fence has its more carefully made gate, swinging on iron hinges and fastened with a hook. Sometimes its posts are connected high overhead by a cross beam,—a "gallows gate,"—past which one would think the murderer must steal with terror as he skulks along in the gloaming.

The sound of letting down the bars is a familiar one to New England ears, and after the five or six resonant wooden clangs, one

listens to hear the cow-boy lift up his voice, or the farmer call his sheep. The rail fence is a stile all along its length, and so is a stone wall, though a stone or so is apt to tumble down if you clamber over it in an unaccustomed place. The footpath runs right over the rail fence, as easy to be seen in the polishing of the top rail as in the trodden sward. On some much frequented ways "across lots" as to a spring, a slanted plank on either side the fence affords a comfortable passage, and down their pleasant incline a boy can no more walk than his marbles could. Let no one feel too proud to crawl through a stump fence, but be humbly thankful if he can find a hole that will give him passage. A bird can go over one very comfortably, and likewise over a brush fence, and this last nothing without wings can do; man and every beast larger than a squirrel must wade through it, unless they have the luck to come to a pole-barway in it.

A chapter might be written of fence breakers and leapers; of wickedly wise cows who unhook gates and toss off rails almost as handily as if they were human; of sheep who find holes that escape the eyes of their owners, and go through them with a flourish of trumpets like a victorious army that has breached the walls of a city; of horses who, in spite of pokes, take fences like trained steeple-chasers, and another chapter of fence walkers, too,—for the rail fence and stone wall are convenient highways for the squirrel whereon to pass from nut-tree and corn-field to store-house and home, and for puss to pick her dainty way, dry-footed, to and from her mousing and bird-peaching in the fields; the coon walks there, and Reynard makes them a link in the chain of his subtle devices.

One cannot help thinking of the possibility that, by and by, high farming may become universal, and soiling may become the common practice of farmers, and that then the building and keeping up of fences will end with the need of them, and the boundaries of farms be marked only by iron posts or stone pillars; then the old landmarks of gray fences, with their trees and shrubs and flowering weeds, will have passed away and no herds of kine or flocks of sheep dot the fields; and then, besides men and teams, there will be no living thing larger than a bird in the wide landscape. The prospect of such a time goes, with many other things, to reconcile one to the thought, that before that day his eyes will be closed in a sleep which such changed scenes will not trouble.

LOUISIANA.*

BY FRANCES HODGSON BURNETT,

Author of "That Lass o' Lowrie's," "Surlly Tim, and Other Stories," "Haworth's," etc.



"WALK ACROSS THE FLOOR," COMMANDED MISS FERROL.

CHAPTER I.

LOUISIANA.

OLIVIA FERROL leaned back in her chair, her hands folded upon her lap. People passed and repassed her as they promenade the long "gallery," as it was called; they passed in couples, in trios; they talked with unnecessary loudness, they laughed at their own and each other's jokes; they flirted, they sentimentalized, they criticised each other, but none of them showed any special interest in Olivia Ferrol, nor did Miss Ferrol, on her part, show much interest in them.

She had been at Oakvale Springs for two or three weeks. She was alone, out of her element, and knew nobody. The fact that she was a New Yorker, and had never before been so far South, was rather against her. On her arrival she had been glanced over and commented upon with candor.

"She is a Yankee," said the pretty and remarkably youthful-looking mother of an apparently grown-up family from New Orleans. "You can see it."

And though the remark was not meant to be exactly severe, Olivia felt that it was very severe, indeed, under existing circumstances. She heard it as she was giving her orders for breakfast to her own particular jet-black and highly excitable waiter, and she felt guilty at once and blushed, hastily taking a sip of ice-water to conceal her confusion. When she went upstairs afterward she wrote a very interesting letter to her brother in New York, and tried to make an analysis of her sentiments for his edification.

"You advised me to come here because it would be novel as well as beneficial," she wrote. "And it certainly is novel. I think I feel like a pariah—a little. I am aware that even the best bred and most intelligent of them, hearing that I have always lived in New York, will privately regret it if

they like me and remember it if they dislike me. Good-natured and warm-hearted as they seem among themselves, I am sure it will be I who will have to make the advances—if advances are made—and I must be very amiable, indeed, if I intend they shall like me.”

But she had not been well enough at first to be in the humor to make the advances, and consequently had not found her position an exciting one. She had looked on until she had been able to rouse herself to some pretty active likes and dislikes, but she knew no one.

She felt this afternoon as if this mild recreation of looking on had begun rather to pall upon her, and she drew out her watch, glancing at it with a little yawn.

“It is five o'clock,” she said. “Very soon the band will make its appearance, and it will bray until the stages come in. Yes, there it is!”

The musical combination to which she referred was composed of six or seven gentlemen of color who played upon brazen instruments, each in different keys and different time. Three times a day they collected on a rustic kiosk upon the lawn and played divers popular airs with an intensity, fervor, and muscular power worthy of a better cause. They straggled up as she spoke, took their places and began, and before they had played many minutes the most exciting event of the day occurred, as it always did somewhere about this hour. In the midst of the gem of their collection, was heard the rattle of wheels and the crack of whips, and through the rapturous shouts of the juvenile guests, the two venerable, rickety stages dashed up with a lumbering flourish, and a spasmodic pretense of excitement, calculated to deceive only the feeblest mind.

At the end of the gallery they checked themselves in their mad career, the drivers making strenuous efforts to restrain the impetuosity of the four steeds whose harness rattled against their ribs with an unpleasant bony sound. Half a dozen waiters rushed forward, the doors were flung open, the steps let down with a bang, the band brayed insanelly, and the passengers alighted.

“One, two, three, four,” counted Olivia Ferrol, mechanically, as the first vehicle unburdened itself. And then, as the door of the second was opened: “One—only one; and a very young one, too. Dear me! Poor girl!”

This exclamation might naturally have fallen from any quick-sighted and sympa-

thetic person. The solitary passenger of the second stage stood among the crowd, hesitating, and plainly overwhelmed with timorousness. Three waiters were wrestling with an ugly shawl, a dreadful shining valise, and a painted wooden trunk, such as is seen in country stores. In their enthusiastic desire to dispose creditably of these articles they temporarily forgot the owner, who, after one desperate, timid glance at them, looked round her in vain for succor. She was very pretty and very young and very ill-dressed—her costume a bucolic travesty on prevailing modes. She did not know where to go, and no one thought of showing her; the loungers about the office stared at her; she began to turn pale with embarrassment and timidity. Olivia Ferrol left her chair and crossed the gallery. She spoke to a servant a little sharply:

“Why not show the young lady into the parlor?” she said.

The girl heard, and looked at her helplessly, but with gratitude. The waiter darted forward with hospitable rapture.

“Dis yeah’s de way, miss,” he said, “right inter de ’ception-room. Foller me, ma’am.”

Olivia returned to her seat. People were regarding her with curiosity, but she was entirely oblivious of the fact.

“That is one of them,” she was saying, mentally. “That is one of them, and a very interesting type it is, too.”

To render the peculiarities of this young woman clearer, it may be well to reveal here something of her past life and surroundings. Her father had been a literary man, her mother an illustrator of books and magazine articles. From her earliest childhood she had been surrounded by men and women of artistic or literary occupations, some who were drudges, some who were geniuses, some who balanced between the two extremes, and she had unconsciously learned the tricks of the trade. She had been used to people who continually had their eyes open to anything peculiar and interesting in human nature, who were enraptured by the discovery of new types of men, women, and emotions. Since she had been left an orphan she had lived with her brother, who had been reporter, editor, contributor, critic, one after the other, until at last he had established a very enviable reputation as a brilliant, practical young fellow, who knew his business, and had a fine career open to him. So it was natural that, having become interested in the general

friendly fashion of dissecting and studying every scrap of human nature within reach, she had followed more illustrious examples, and had become very critical upon the subject of "types" herself. During her sojourn at Oakvale she had studied the North Carolinian mountaineer "type" with the enthusiasm of an amateur. She had talked to the women in sunbonnets who brought fruit to the hotel, and sat on the steps and floor of the galleries awaiting the advent of customers with a composure only to be equaled by the calmness of the noble savage; she had walked and driven over the mountain roads, stopping at way-side houses and entering into conversation with the owners until she had become comparatively well known, even in the space of a fortnight, and she had taken notes for her brother until she had roused him to sharing her own interest in her discoveries.

"I am sure you will find a great deal of material here," she wrote to him. "You see how I have fallen a victim to that dreadful habit of looking at everything in the light of material. A man is no longer a man—he is 'material'; sorrow is not sorrow, joy is not joy—it is 'material.' There is something rather ghoulish in it. I wonder if anatomists look at people's bodies as we do at their minds, and if to them every one is a 'subject.' At present I am interested in a species of girl I have discovered. Sometimes she belongs to the better class—the farmers, who have a great deal of land and who are the rich men of the community,—sometimes she lives in a log cabin with a mother who smokes and chews tobacco, but in either case she is a surprise and a mystery. She is always pretty, she is occasionally beautiful, and in spite of her house, her people, her education or want of it, she is instinctively a refined and delicately susceptible young person. She has always been to some common school, where she has written compositions on sentimental or touching subjects, and when she belongs to the better class she takes a fashion magazine and tries to make her dresses like those of the ladies in the colored plate, and, I may add, frequently fails. I could write a volume about her, but I wont. When your vacation arrives, come and see for yourself." It was of this class Miss Ferrol was thinking when she said: "That is one of them, and a very interesting type it is, too."

When she went in to the dining-room to partake of the six o'clock supper, she glanced

about her in search of the new arrival, but she had not yet appeared. A few minutes later, however, she entered. She came in slowly, looking straight before her, and trying very hard to appear at ease. She was prettier than before, and worse dressed. She wore a blue, much-ruffled muslin and a wide collar made of imitation lace. She had tucked her sleeves up to her elbow with a band and bow of black velvet, and her round, smooth young arms were adorable. She looked for a vacant place, and, seeing none, stopped short, as if she did not know what to do. Then some magnetic attraction drew her eye to Olivia Ferrol's. After a moment's pause, she moved timidly toward her.

"I—I wish a waiter would come," she faltered.

At that moment one on the wing stopped in obedience to a gesture of Miss Ferrol's—a delicate, authoritative movement of the head.

"Give this young lady that chair opposite me," she said.

The chair was drawn out with a flourish, the girl was seated, and the bill of fare was placed in her hands.

"Thank you," she said, in a low, astonished voice.

Olivia smiled.

"That waiter is my own special and peculiar property," she said, "and I rather pride myself on him."

But her guest scarcely seemed to comprehend her pleasantry. She looked somewhat awkward.

"I—don't know much about waiters," she ventured. "I'm not used to them, and I suppose they know it. I never was at a hotel before."

"You will soon get used to them," returned Miss Ferrol.

The girl fixed her eyes upon her with a questioning appeal. They were the loveliest eyes she had ever seen, Miss Ferrol thought—large-irised, and with wonderful long lashes fringing them and curling upward, giving them a tender, very wide-open look. She seemed suddenly to gain courage, and also to feel it her duty to account for herself.

"I shouldn't have come here alone if I could have got father to come with me," she revealed. "But he wouldn't come. He said it wasn't the place for him. I haven't been very well since mother died, and he thought I'd better try the Springs awhile. I don't think I shall like it."

"I don't like it," replied Miss Ferrol, candidly, "but I dare say you will when you know people."

The girl glanced rapidly and furtively over the crowded room, and then her eyes fell.

"I shall never know them," she said, in a depressed undertone.

In secret Miss Ferrol felt a conviction that she was right; she had not been presented under the right auspices.

"It is rather clever and sensitive in her to find it out so quickly," she thought. "Some girls would be more sanguine, and be led into blunders."

They progressed pretty well during the meal. When it was over, and Miss Ferrol rose, she became conscious that her companion was troubled by some new difficulty, and a second thought suggested to her what its nature was.

"Are you going to your room?" she asked.

"I don't know," said the girl, with the look of helpless appeal again. "I don't know where else to go. I don't like to go out there" (signifying the gallery) "alone."

"Why not come with me?" said Miss Ferrol. "Then we can promenade together."

"Ah!" she said, with a little gasp of relief and gratitude. "Don't you mind?"

"On the contrary, I shall be very glad of your society," Miss Ferrol answered. "I am alone, too."

So they went out together and wandered slowly from one end of the starlit gallery to the other, winding their way through the crowd that promenaded, and, upon the whole, finding it rather pleasant.

"I shall have to take care of her," Miss Ferrol was deciding; "but I do not think I shall mind the trouble."

The thing that touched her most was the girl's innocent trust in her sincerity—her taking for granted that this stranger, who had been polite to her, had been so not for worldly good breeding's sake, but from true friendliness and extreme generosity of nature. Her first shyness conquered, she related her whole history with the unreserve of a child. Her father was a farmer, and she had always lived with him on his farm. He had been too fond of her to allow her to leave home, and she had never been "away to school."

"He has made a pet of me at home," she said. "I was the only one that lived to be over eight years old. I am the elev-

enth. Ten died before I was born, and it made father and mother worry a good deal over me—and father was worse than mother. He said the time never seemed to come when he could spare me. He is very good and kind—is father," she added, in a hurried, soft-voiced way. "He's rough—but he's very good and kind."

Before they parted for the night Miss Ferrol had the whole genealogical tree by heart. They were an amazingly prolific family, it seemed. There was Uncle Josiah, who had ten children, Uncle Leander, who had fifteen, Aunt Amanda, who had twelve, and Aunt Nervy, whose belongings comprised three sets of twins and an unlimited supply of odd numbers. They went upstairs together and parted at Miss Ferrol's door, their rooms being near each other.

The girl held out her hand.

"Good-night!" she said. "I'm so thankful I've got to know you."

Her eyes looked bigger and wider-open than ever; she smiled, showing her even, sound, little white teeth. Under the bright light of the lamp the freckles the day betrayed on her smooth skin were not to be seen.

"Dear me!" thought Miss Ferrol. "How startlingly pretty, in spite of the cotton lace and the dreadful polonaise!"

She touched her lightly on the shoulder.

"Why, you are as tall as I am!" she said.

"Yes," the girl replied, depressedly; "but I'm twice as broad."

"Oh no—no such thing." And then, with a delicate glance down over her, she said—"It is your dress that makes you fancy so. Perhaps your dress-maker does not understand your figure,"—as if such a failing was the most natural and simple thing in the world, and needed only the slightest rectifying.

"I have no dress-maker," the girl answered. "I make my things myself. Perhaps that is it."

"It is a little dangerous, it is true," replied Miss Ferrol. "I have been bold enough to try it myself, and I never succeeded. I could give you the address of a very thorough woman if you lived in New York."

"But I don't live there, you see. I wish I did. I never shall, though. Father could never spare me."

Another slight pause ensued, during which she looked admiringly at Miss Ferrol. Then she said "good-night" again, and turned away.

But before she had crossed the corridor she stopped.

"I never told you my name," she said.

Miss Ferrol naturally expected she would announce it at once, but she did not. An air of embarrassment fell upon her. She seemed almost averse to speaking.

"Well," said Miss Ferrol, smiling, "what is it?"

She did not raise her eyes from the carpet as she replied, unsteadily:

"It's Louisiana."

Miss Ferrol answered her very composedly:

"The name of the state?"

"Yes. Father came from there."

"But you did not tell me your surname."

"Oh! that is Rogers. You—you didn't laugh. I thought you would."

"At the first name?" replied Miss Ferrol. "Oh no. It is unusual—but names often are. And Louise is pretty."

"So it is," she said, brightening. "I never thought of that. I hate Louisa. They will call it 'Lowizy,' or 'Lousyanny.' I could sign myself Louise, couldn't I?"

"Yes," Miss Ferrol replied.

And then her *protégée* said "good-night" for the third time, and disappeared.

CHAPTER II.

WORTH.

SHE presented herself at the bed-room door with a timid knock the next morning before breakfast, evidently expecting to be taken charge of. Miss Ferrol had felt sure she would appear, and had, indeed, dressed herself in momentary expectation of hearing the knock.

When she heard it she opened the door at once.

"I am glad to see you," she said. "I thought you might come."

A slight expression of surprise showed itself in the girl's eyes. It had never occurred to her that she might not come.

"Oh, yes," she replied. "I never could go down alone when there was any one who would go with me."

There was something on her mind, Miss Ferrol fancied, and presently it burst forth in a confidential inquiry.

"Is this dress very short-waisted?" she asked, with great earnestness.

Merciful delicacy stood in the way of Miss Ferrol's telling her how short-waisted it was, and how it maltreated her beautiful young body.

"It is rather short-waisted, it is true."

"Perhaps," the girl went on, with a touch of guileless melancholy, "I am naturally this shape."

Here, it must be confessed, Miss Ferrol forgot herself for the moment, and expressed her indignation with undue fervor.

"Perish the thought!" she exclaimed. "Why, child! your figure is a hundred times better than mine."

Louisiana wore for a moment a look of absolute fright.

"Oh, no!" she cried. "Oh, no. Your figure is magnificent."

"Magnificent!" echoed Miss Ferrol, giving way to her enthusiasm, and indulging in figures of speech. "Don't you see that I am thin—absolutely thin. Nothing would induce me to appear in full dress. I am always clothed to my ears. But my things fit me, and my dress-maker understands me. If you were dressed as I am,"—pausing to look her over from head to foot—"Ah!" she exclaimed, pathetically, "how I should like to see you in some of my clothes!"

A tender chord was touched. A gentle sadness, aroused by this instance of wasted opportunities, rested upon her. But instantaneously she brightened, seemingly without any particular cause. A brilliant idea had occurred to her. But she did not reveal it.

"I will wait," she thought, "until she is more at her ease with me."

She really was more at her ease already. Just this one little scrap of conversation had done that. She became almost affectionate in a shy way before they reached the dining-room.

"I want to ask you something," she said, as they neared the door.

"What is it?"

She held Miss Ferrol back with a light clasp on her arm. Her air was quite tragic in a small way.

"Please say 'Louise,' when you speak to me," she said. "Never say 'Miss Louisiana'—never—never!"

"No, I shall never say 'Miss Louisiana,'" her companion answered. "How would you like 'Miss Rogers?'"

"I would rather have 'Louise,'" she said, disappointedly.

"Well," returned Miss Ferrol, "'Louise' let it be."

And "Louise" it was thenceforward. If she had not been so pretty, so innocent, and so affectionate and humble a young creature, she might have been troublesome

at times (it occurred to Olivia Ferrol), she clung so pertinaciously to their chance acquaintanceship; she was so helpless and desolate if left to herself, and so inordinately glad to be taken in hand again. She made no new friends,—which was perhaps natural enough, after all. She had nothing in common with the young women who played ten-pins and croquet and rode out in parties with their cavaliers. She was not of them, and understood them as little as they understood her. She knew very well that they regarded her with scornful tolerance when they were of the ill-natured class, and with ill-subdued wonder when they were amiable. She could not play ten-pins and croquet, nor could she dance.

“What are the men kneeling down for, and why do they keep stopping to put on those queer little caps and things?” she whispered to Miss Ferrol one night.

“They are trying to dance a German,” replied Miss Ferrol, “and the man who is leading them only knows one figure.”

As for the riding, she had been used to riding all her life; but no one asked her to join them, and if they had done so she would have been too wise,—unsophisticated as she was,—to accept the invitation. So where Miss Ferrol was seen she was seen also, and she was never so happy as when she was invited into her protector's room and allowed to spend the morning or evening there. She would have been content to sit there forever and listen to Miss Ferrol's graphic description of life in the great world. The names of celebrated personages made small impression upon her. It was revealed gradually to Miss Ferrol that she had private doubts as to the actual existence of some of them, and the rest she had never heard of before.

“You never read ‘The Scarlet Letter?’” asked her instructress upon one occasion.

She flushed guiltily.

“No,” she answered. “Nor—nor any of the others.”

Miss Ferrol gazed at her silently for a few moments. Then she asked her a question in a low voice, specially mellowed, so that it might not alarm her.

“Do you know who John Stuart Mill is?” she said.

“No,” she replied from the dust of humiliation.

“Have you never heard—just *heard*—of Ruskin?”

“No.”

“Nor of Michael Angelo?”

“N-no—ye-es, I think so—perhaps, but I don't know what he did.”

“Do you,” she continued, very slowly, “do—you—know—anything—about—Worth?”

“No, nothing.”

Her questioner clasped her hands with repressed emotion.

“Oh,” she cried, “how—how you have been neglected!”

She was really depressed, but her *protégée* was so much more deeply so that she felt it her duty to contain herself and return to cheerfulness.

“Never mind,” she said. “I will tell you all I know about them, and,”—after a pause for speculative thought upon the subject,—“by-the-by, it isn't much, and I will lend you some books to read, and give you a list of some you must persuade your father to buy for you, and you will be all right. It is rather dreadful not to know the names of people and things; but, after all, I think there are very few people who—ahem!”

She was checked here by rigid conscientious scruples. If she was to train this young mind in the path of learning and literature, she must place before her a higher standard of merit than the somewhat shady and slipshod one her eagerness had almost betrayed her into upholding. She had heard people talk of “standards” and “ideals,” and when she was kept to the point and in regulation working order, she could be very eloquent upon these subjects herself.

“You will have to work very seriously,” she remarked, rather incongruously and with a rapid change of position. “If you wish to—to acquire anything, you must read conscientiously and—with a purpose.” She was rather proud of that last clause.

“Must I?” inquired Louise, humbly. “I should like to—if I knew where to begin. Who was Worth? Was he a poet?”

Miss Ferrol acquired a fine, high color very suddenly.

“Oh,” she answered, with some uneasiness, “you—you have no need to begin with Worth. He doesn't matter so much—really.”

“I thought,” Miss Rogers said meekly, “that you were more troubled about my not having read what he wrote, than about my not knowing any of the others.”

“Oh, no. You see—the fact is, he—he never wrote anything.”

"What did he do?" she asked, anxious for information.

"He—it isn't 'did,' it is 'does.' He—makes dresses."

"Dresses!"

This single word, but no exclamation point could express its tone of wild amazement.

"Yes."

"A man?"

"Yes."

There was a dead silence. It was embarrassing at first. Then the amazement of the unsophisticated one began to calm itself; it gradually died down, and became another emotion, merging itself into interest.

"Does"—guilelessly she inquired—"he make nice ones?"

"Nice!" echoed Miss Ferrol. "They are works of art! I have got three in my trunk."

"O-o-h!" sighed Louisiana. "Oh, dear!"

Miss Ferrol rose from her chair.

"I will show them to you," she said. "I—I should like you to try them on."

"To try them on!" ejaculated the child in an awe-stricken tone. "Me?"

"Yes," said Miss Ferrol, unlocking the trunk and throwing back the lid. "I have been wanting to see you in them since the first day you came."

She took them out and laid them upon the bed on their trays. Louise got up from the floor and approaching, reverently stood near them. There was a cream-colored evening-dress of soft, thick, close-clinging silk of some antique-modern sort; it had golden fringe, and golden flowers embroidered upon it.

"Look at that," said Miss Ferrol, softly—even religiously.

She made a mysterious, majestic gesture.

"Come here," she said. "You must put it on."

Louise shrank back a pace.

"I—oh! I daren't," she cried. "It is too beautiful!"

"Come here," repeated Miss Ferrol.

She obeyed timidly, and gave herself into the hands of her controller. She was so timid and excited that she trembled all the time her toilette was being performed for her. Miss Ferrol went through this service with the manner of a priestess officiating at an altar. She laced up the back of the dress with the slender, golden cords; she arranged the antique drapery which wound

itself around in close swathing folds. There was not the shadow of a wrinkle from shoulder to hem: the lovely young figure was revealed in all its beauty of outline. There were no sleeves at all, there was not very much bodice, but there was a great deal of effect, and this, it is to be supposed, was the object.

"Walk across the floor," commanded Miss Ferrol.

Louisiana obeyed her.

"Do it again," said Miss Ferrol.

Having been obeyed for the second time, her hands fell together. Her attitude and expression could be said to be significant only of rapture.

"I said so!" she cried. "I said so! You might have been born in New York!"

It was a grand climax. Louisiana felt it to the depths of her reverent young heart. But she could not believe it. She was sure that it was too sublime to be true. She shook her head in deprecation.

"It is no exaggeration," said Miss Ferrol, with renewed fervor. "Laurence himself, if he were not told that you had lived here, would never guess it. I should like to try you on him."

"Who—is he?" inquired Louisiana. "Is he a writer, too?"

"Well, yes,—but not exactly like the others. He is my brother."

It was two hours before this episode ended. Only at the sounding of the second bell did Louisiana escape to her room to prepare for dinner.

Miss Ferrol began to replace the dresses in her trunk. She performed her task in an abstracted mood. When she had completed it she stood upright and paused a moment, with quite a startled air.

"Dear me!" she exclaimed. "I—actually forgot about Ruskin!"

CHAPTER III.

"HE IS DIFFERENT."

THE same evening, as they sat on one of the seats upon the lawn, Miss Ferrol became aware several times that Louisiana was regarding her with more than ordinary interest. She sat with her hands folded upon her lap, her eyes fixed on her face, and her pretty mouth actually a little open.

"What are you thinking of?" Olivia asked, at length.

The girl started, and recovered herself with an effort.

"I—well, I was thinking about—authors," she stammered.

"Any particular author?" inquired Olivia, "or authors as a class?"

"About your brother being one. I never thought I should see any one who knew an author—and you are related to one!"

Her companion's smile was significant of immense experience. It was plain that she was so accustomed to living on terms of intimacy with any number of authors that she could afford to feel indifferent about them.

"My dear," she said, amiably, "they are not in the least different from other people."

It sounded something like blasphemy.

"Not different!" cried Louisiana. "Oh, surely, they must be! Isn't—isn't your brother different?"

Miss Ferrol stopped to think. She was very fond of her brother. Privately she considered him the literary man of his day. She was simply disgusted when she heard experienced critics only calling him "clever" and "brilliant" instead of "great" and "world-moving."

"Yes," she replied at length, "he is different."

"I thought he must be," said Louisiana, with a sigh of relief. "You are, you know."

"Am I?" returned Olivia. "Thank you. But I am not an author—at least"—she added, guiltily, "nothing I have written has ever been published."

"Oh, why not?" exclaimed Louisiana.

"Why not?" she repeated, dubiously and thoughtfully. And then, knitting her brows, she said, "I don't know why not."

"I am sure if you have ever written anything, it ought to have been published," protested her adorer.

"I thought so," said Miss Ferrol. "But—but *they* didn't."

"They?" echoed Louisiana. "Who are 'they'?"

"The editors," she replied, in a rather gloomy manner. "There is a great deal of wire-pulling, and favoritism, and—even envy and malice, of which those outside know nothing. You wouldn't understand it if I should tell you about it."

For a few moments she wore quite a fallen expression, and gloom reigned. She gave her head a little shake.

"They regret it afterward," she remarked,—"frequently."

From which Louisiana gathered that it was the editors who were so overwhelmed, and she could not help sympathizing with them in secret. There was something in

the picture of their unavailing remorse which touched her, despite her knowledge of the patent fact that they deserved it and could expect nothing better. She was quite glad when Olivia brightened up, as she did presently.

"Laurence is handsomer than most of them, and has a more distinguished air," she said. "He is very charming. People always say so."

"I wish I could see him," ventured Louisiana.

"You will see him if you stay here much longer," replied Miss Ferrol. "It is quite likely he will come to Oakvale."

For a moment Louisiana fluttered and turned pale with pleasure, but as suddenly she drooped.

"I forgot," she faltered. "You will have to be with him always, and I shall have no one. He won't want me."

Olivia sat and looked at her with deepening interest. She was thinking again of a certain whimsical idea which had beset her several times since she had attired her *protégée* in the cream-colored robe.

"Louise," she said, in a low, mysterious tone, "how would you like to wear dresses like mine all the rest of the time you are here?"

The child stared at her blankly.

"I haven't got any," she gasped.

"No," said Miss Ferrol, with deliberation, "but *I* have."

She rose from the seat, dropping her mysterious air and smiling encouragingly.

"Come with me to my room," she said.

"I want to talk to you."

If she had ordered her to follow her to the stake it is not at all unlikely that Louisiana would have obeyed. She got up meekly, smiling, too, and feeling sure something very interesting was going to happen. She did not understand in the least, but she was quite tractable. And after they had reached the room and shut themselves in, she found that it *was* something very interesting which was to happen.

"You remember what I said to you this morning?" Miss Ferrol suggested.

"You said so many things."

"Oh, but you cannot have forgotten this particular thing. I said you looked as if you had been born in New York."

Louisiana remembered with a glow of rapture.

"Oh, yes," she answered.

"And I said Laurence himself would not know, if he was not told, that you had lived all your life here."

"Yes."

"And I said I should like to try you on him."

"Yes."

Miss Ferrol kept her eyes fixed on her and watched her closely.

"I have been thinking of it all the morning," she added. "I should like to try you on him."

Louisiana was silent a moment. Then she spoke, hesitatingly:

"Do you mean that I should pretend —" she began.

"Oh, no," interrupted Miss Ferrol. "Not pretend either one thing or the other. Only let me dress you as I choose, and then take care that you say nothing whatever about your past life. You will have to be rather quiet, perhaps, and let him talk. He will like that, of course—men always do—and then you will learn a great many things from him."

"It will be—a very strange thing to do," said Louisiana.

"It will be a very interesting thing," answered Olivia, her enthusiasm increasing. "How he will admire you!"

Louisiana indulged in one of her blushes.

"Have you a picture of him?"

"Yes. Why?" she asked, in some surprise.

"Because I should like to see his face."

"Do you think," Miss Ferrol said, in further bewilderment, "that you might not like him?"

"I think he might not like me."

"Not like you!" cried Miss Ferrol.

"You! He will think you are divine—when you are dressed as I shall dress you."

She went to her trunk and produced the picture. It was not a photograph, but a little crayon head—the head of a handsome man, whose expression was a singular combination of dreaminess and alertness. It was a fascinating face.

"One of his friends did it," said Miss Ferrol. "His friends are very fond of him and admire his good looks very much. They protest against his being photographed. They like to sketch him. They are always making 'studies' of his head. What do you think of him?"

Louisiana hesitated.

"He is different," she said at last. "I thought he would be."

She gave the picture back to Miss Ferrol, who replaced it in her trunk. She sat for a few seconds looking down at the carpet and apparently seeing very little. Then she

looked up at her companion, who was suddenly a little embarrassed at finding her receive her whimsical planning so seriously. She herself had not thought of it as being serious at all. It would be interesting and amusing, and would prove her theory.

"I will do what you want me to do," said Louisiana.

"Then," said Miss Ferrol, wondering at an unexpected sense of discomfort in herself, "I will dress you for supper now. You must begin to wear the things, so that you may get used to them."

CHAPTER IV.

A NEW TYPE.

WHEN the two entered the supper-room together a little commotion was caused by their arrival. At first the supple young figure in violet and gray was not recognized. It was not the figure people had been used to, it seemed so tall and slenderly round. The reddish-brown hair was combed high and made into soft puffs; it made the pretty head seem more delicately shaped, and showed how white and graceful the back of the slender neck was. It was several minutes before the problem was solved. Then a sharp young woman exclaimed, *sotto voce*:

"It's the little country-girl, in new clothes—in clothes that fit. Would you believe it?"

"Don't look at your plate so steadily," whispered Miss Ferrol. "Lean back and fan yourself as if you did not hear. You must never show that you hear things."

"I shall be obliged to give her a few hints now and then," she had said to herself beforehand. "But I feel sure when she once catches the cue she will take it."

It really seemed as if she did, too. She had looked at herself long and steadily after she had been dressed, and when she turned away from the glass she held her head a trifle more erect, and her cheeks had reddened. Perhaps what she had recognized in the reflection she had seen had taught her a lesson. But she said nothing. In a few days Olivia herself was surprised at the progress she had made. Sanguine as she was, she had not been quite prepared for the change which had taken place in her. She had felt sure it would be necessary to teach her to control her emotions, but suddenly she seemed to have learned to control them without being told to do so; she was no longer demon-

strative of her affection, she no longer asked innocent questions, nor did she ever speak of her family. Her reserve was puzzling to Olivia.

"You are very clever," she said to her one day, the words breaking from her in spite of herself, after she had sat regarding her in silence for a few minutes. "You are even cleverer than I thought you were, Louise."

"Was that very clever?" the girl asked.

"Yes, it was," Olivia answered, "but not so clever as you are proving yourself."

But Louisiana did not smile or blush, as she had expected she would. She sat very quietly, showing neither pleasure nor shyness, and seeming for a moment or so to be absorbed in thought.

In the evening when the stages came in they were sitting on the front gallery together. As the old rattletraps bumped and swung themselves up the gravel drive, Olivia bent forward to obtain a better view of the passengers.

"He ought to be among them," she said.

Louisiana laid her hand on her arm.

"Who is that sitting with the driver?" she asked, as the second vehicle passed them. "Isn't that——"

"To be sure it is!" exclaimed Miss Ferrol.

She would have left her seat, but she found herself detained. Her companion had grasped her wrist.

"Wait a minute!" she said. "Don't leave me! Oh—I wish I had not done it!"

Miss Ferrol turned and stared at her in amazement.

She spoke in her old, uncontrolled, childish fashion. She was pale, and her eyes were dilated.

"What is the matter?" said Miss Ferrol, hurriedly, when she found her voice. "Is it that you really don't like the idea? If you don't, there is no need of our carrying it out. It was only nonsense—I beg your pardon for not seeing that it disturbed you. Perhaps, after all, it was very bad taste in me——"

But she was not allowed to finish her sentence. As suddenly as it had altered before, Louisiana's expression altered again. She rose to her feet with a strange little smile. She looked into Miss Ferrol's astonished face steadily and calmly.

"Your brother has seen you and is coming toward us," she said. "I will leave you. We shall see each other again at supper."

And with a little bow she moved away with an air of composure which left her instructress stunned. She could scarcely recover her equilibrium sufficiently to greet her brother decently when he reached her side. She had never been so thoroughly at sea in her life.

After she had gone to her room that night, her brother came and knocked at the door.

When she opened it and let him in he walked to a chair and threw himself into it, wearing a rather excited look.

"Olivia," he began at once, "what a bewildering girl!"

Olivia sat down opposite to him, with a composed smile.

"Miss Rogers, of course?" she said.

"Of course," he echoed. And then, after a pause of two or three seconds, he added, in the tone he had used before: "What a delightfully mysterious girl!"

"Mysterious!" repeated Olivia.

"There is no other word for it!" "She has such an adorable face, she looks so young, and she says so little." And then, with serious delight, he added: "It is a new type!"

Olivia began to laugh.

"Why are you laughing?" he demanded.

"Because I was so sure you would say that," she answered. "I was waiting for it."

"But it is true," he replied, quite vehemently. "I never saw anything like her before. I look at her great soft eyes and I catch glimpses of expression which don't seem to belong to the rest of her. When I see her eyes I could fancy for a moment that she had been brought up in a convent or had lived a very simple, isolated life, but when she speaks and moves I am bewildered. I want to hear her talk, but she says so little. She does not even dance. I suppose her relatives are serious people. I dare say you have not heard much of them from her. Her reserve is so extraordinary in a girl. I wonder how old she is?"

"Nineteen, I think."

"I thought so. I never saw anything prettier than her quiet way when I asked her to dance with me. She said, simply, 'I do not dance. I have never learned.' It was as if she had never thought of it as being an unusual thing."

He talked of her all the time he remained in the room. Olivia had never seen him so interested before.

"The fascination is that she seems to be two creatures at once," he said. "And one of them is stronger than the other and will break out and reveal itself one day. I begin by feeling I do not understand her, and that is the most interesting of all beginnings. I long to discover which of the two creatures is the real one."

When he was going away he stopped suddenly to say:

"How was it you never mentioned her in your letters? I can't understand that."

"I wanted you to see her for yourself," Olivia answered. "I thought I would wait."

"Well," he said, after thinking a moment, "I am glad, after all, that you did."

CHAPTER V.

"I HAVE HURT YOU."

FROM the day of his arrival a new life began for Louisiana. She was no longer an obscure and unconsidered young person. Suddenly, and for the first time in her life, she found herself vested with a marvelous power. It was a power girls of a different class from her own are vested with from the beginning of their lives. They are used to it and regard it as their birthright. Louisiana was not used to it. There had been nothing like it attending her position as "that purty gal o' Rogerses." She was accustomed to the admiration of men she was indifferent to—men who wore short-waisted blue-jean coats, and turned upon their elbows to stare at her as she sat in the little white frame church. After making an effort to cultivate her acquaintance, they generally went away disconcerted. "She's mighty still," they said. "She haint got nothin' to say. Seems like thar aint much to her—but she's powerful purty though."

This was nothing like her present experience. She began slowly to realize that she was a little like a young queen now. Here was a man such as she had never spoken to before, who was always ready to endeavor to his utmost to please her: who, without any tendency toward sentimental nonsense, was plainly the happier for her presence and favor. What could be more assiduous and gallant than the every-day behavior of the well-bred, thoroughly experienced young man of the period toward the young beauty who for the moment reigns over his fancy! It need only be over his fancy; there is no necessity that the impression should be any deeper. His suavity,

his chivalric air, his ready wit in her service, are all that could be desired.

When Louisiana awakened to the fact that all this homage was rendered to her as being only the natural result of her girlish beauty—as if it was the simplest thing in the world, and a state of affairs which must have existed from the first—she experienced a sense of terror. Just at the very first she would have been glad to escape from it and sink into her old obscurity.

"It does not belong to me," she said to herself. "It belongs to some one else—to the girl he thinks I am. I am not that girl, though; I will remember that."

But in a few days she calmed down. She told herself that she always did remember, but she ceased to feel frightened and was more at ease. She never talked very much, but she became more familiar with the subjects she heard discussed. One morning she went to Olivia's room and asked her for the address of a bookseller.

"I want to send for some books and—and magazines," she said, confusedly. "I wish you—if you would tell me what to send for. Father will give me the money if I ask him for it."

Olivia sat down and made a list. It was a long list, comprising the best periodicals of the day and several standard books.

When she handed it to her she regarded her with curiosity.

"You mean to read them all?" she asked.

"Isn't it time that I should?" replied her pupil.

"Well—it is a good plan," returned Olivia, rather absently.

Truth to tell, she was more puzzled every day. She had begun to be quite sure that something singular had happened. It seemed as if a slight coldness existed between herself and her whilom adorer. The simplicity of her enthusiasm was gone. Her affection had changed as her outward bearing had. It was a better regulated and less noticeable emotion. Once or twice Olivia had fancied she had seen the girl looking at her even sadly, as if she felt, for the moment, a sense of some loss.

"Perhaps it was very clumsy in me," she used to say to herself. "Perhaps I don't understand her, after all."

But she could not help looking on with interest. She had never before seen Laurence enjoy himself so thoroughly. He had been working very hard during the past year, and was ready for his holiday.

He found the utter idleness, which was the chief feature of the place, a good thing. There was no town or village within twenty miles, newspapers were a day or two old when they arrived, there were very few books to be found, and there was absolutely no excitement. At night the band brayed in the empty-looking ball-room, and a few very young couples danced, in a desultory fashion and without any ceremony. The primitive, domesticated slowness of the place was charming. Most of the guests had come from the far South at the beginning of the season and would remain until the close of it; so they had had time to become familiar with each other and to throw aside restraint.

"There is nothing to distract one," Ferrol said, "nothing to rouse one, nothing to inspire one—nothing! It is delicious! Why didn't I know of it before?"

He had plenty of time to study his sister's friend. She rode and walked with himself and Olivia when they made their excursions, she listened while he read aloud to them as he lay on the grass in a quiet corner of the grounds. He thought her natural reserve held her from expressing her opinion on what he read very freely; it certainly did not occur to him that she was beginning her literary education under his guidance. He could see that the things which pleased him most were not lost upon her. Her face told him that. One moonlight night, as they sat on an upper gallery, he began to speak of the novelty of the aspect of the country as it presented itself to an outsider who saw it for the first time.

"It is a new life, and a new people," he said. "And, by the way, Olivia, where is the new species of young woman I was to see—the daughter of the people who does not belong to her sphere?"

He turned to Louisiana.

"Have you ever seen her?" he asked. "I must confess to, a dubiousness on the subject."

Before he could add another word Louisiana turned upon him. He could see her face clearly in the moonlight. It was white, and her eyes were dilated and full of fire.

"Why do you speak in that way?" she cried. "As if—as if such people were so far beneath you. What right have you——"

She stopped suddenly. Laurence Ferrol was gazing at her in amazement. She rose from her seat, trembling.

"I will go away a little," she said. "I beg your pardon—and Miss Ferrol's."

She turned her back upon them and went away. Ferrol sat holding her little round, white-feather fan helplessly, and staring after her until she disappeared.

It was several seconds before the silence was broken. It was he who broke it.

"I don't know what it means," he said, in a low voice. "I don't know what I have done!"

In a little while he got up and began to roam aimlessly about the gallery. He strolled from one end to the other with his hands thrust in his coat pockets. Olivia, who had remained seated, knew that he was waiting in hopes that Louisiana would return. He had been walking to and fro, looking as miserable as possible, for about half an hour, when at last she saw him pause and turn half round before the open door of an upper corridor leading out upon the verandah. A black figure stood revealed against the inside light. It was Louisiana, and, after hesitating a moment, she moved slowly forward.

She had not recovered her color, but her manner was perfectly quiet.

"I am glad you did not go away," she said.

Ferrol had only stood still at first, waiting her pleasure, but the instant she spoke he made a quick step toward her.

"I should have felt it a very hard thing not to have seen you again before I slept," he said.

She made no reply, and they walked together in silence until they reached the opposite end of the gallery.

"Miss Ferrol has gone in," she said then.

He turned to look and saw that such was the case. Suddenly, for some reason best known to herself, Olivia had disappeared from the scene.

Louisiana leaned against one of the slender, supporting pillars of the gallery. She did not look at Ferrol, but at the blackness of the mountains rising before them. Ferrol could not look away from her.

"If you had not come out again," he said, after a pause, "I think I should have remained here, baying at the moon, all night."

Then, as she made no reply, again he began to pour himself forth quite recklessly.

"I cannot quite understand how I hurt you," he said. "It seemed to me that I must have hurt you, but even while I don't understand, there are no words abject enough to express what I feel now and

have felt during the last half hour. If I only dared ask you to tell me——”

She stopped him.

“I can’t tell you,” she said. “But it is not your fault—it is nothing you could have understood—it is my fault—all my fault, and—I deserve it.”

He was terribly discouraged.

“I am bewildered,” he said. “I am very unhappy.”

She turned her pretty, pale face round to him swiftly.

“It is not you who need be unhappy,” she exclaimed. “It is I!”

The next instant she had checked herself again, just as she had done before.

“Let us talk of something else,” she said, coldly.

“It will not be easy for me to do so,” he answered, “but I will try.”

Before Olivia went to bed she had a visit from her.

She received her with some embarrassment, it must be confessed. Day by day she felt less at ease with her and more deeply self-convicted of some blundering,—which, to a young woman of her temperament, was a sharp penalty.

Louisiana would not sit down. She revealed her purpose in coming at once.

“I want to ask you to make me a promise,” she said, “and I want to ask your pardon.”

“Don’t do that,” said Olivia.

“I want you to promise that you will not tell your brother the truth until you have left here and are at home. I shall go away very soon. I am tired of what I have been doing. It is different from what you meant it to be. But you must promise that if you stay after I have gone—as of course you will—you will not tell him. My home is only a few miles away. You might be tempted, after thinking it over, to come and see me—and I should not like it. I want it all to stop here—I mean my part of it. I don’t want to know the rest.”

Olivia had never felt so helpless in her life. She had neither self-poise, nor tact, nor any other daring quality left.

“I wish,” she faltered, gazing at the girl quite pathetically, “I wish we had never begun it.”

“So do I,” said Louisiana. “Do you promise?”

“Y—yes. I would promise anything. I—I have hurt your feelings,” she confessed, in an outbreak.

She was destined to receive a fresh shock. All at once the girl was metamorphosed again. It was her old ignorant, sweet, simple self who stood there, with trembling lips and dilated eyes.

“Yes, you have!” she cried. “Yes, you have!”

And she burst into tears and turned about and ran out of the room.

(To be continued.)

PRESENT PHASES OF SUNDAY-SCHOOL WORK.

It is intended to celebrate in the year 1880, now just dawning on us, the hundredth anniversary of the foundation by Robert Raikes, of that germinal Sunday-school in Gloucester, England, which became the starting-point of Sunday-school instruction over the greater part of Christendom. A very well-fed and commonplace face comes down to us in engraved portraits of this second and greater “Robert of Gloucester,” but then one cannot tell whether the common-placeness of a portrait is due to the subject or only to the artist. He was not a genius, but a simple, quiet, and somewhat matter-of-fact man, who had, however, the rare trait of acting according to his convictions. He was molded by his time, for he lived just at the

moment when the great tide of religious excitement, set agoing by a few Oxford men in the previous generation, had spent its force, and naturally was being succeeded by that tide of philanthropy the impulse of which is yet with us. John Wesley was then an old man; John Howard was in the height of his activity; and William Wilberforce had just entered parliament. It was the favorable moment for the beginning of such a movement, after the religious excitement, as an excitement, had passed away, just when its first result in philanthropy was beginning to be felt, and long before the deadening reaction to ecclesiasticism and sectarianism had begun. And besides all this, the writings of the incomprehensible Jean Jacques Rousseau had produced by direct

and indirect influence, a tremendous enthusiasm for general education.

Raikes was a man of some culture and of independent means, and was the publisher and proprietor of the "Gloucester Journal." The example of John Howard had no doubt been the moving cause of his previous exertions among the inmates of the county jail and workhouse, which were in a very distressing state. He was impressed with the evil results of the neglect of children by what he saw in the prison; and, walking in the streets thronged by the children of operatives in the pin factory, he came to the determination to found a Sunday-school. He evidently had a genuine sympathy for childhood and the tact to win the love of "the little ragamuffins," as he affectionately styles them. He proposed to teach them to read and to learn the church catechism. But it was not the reading, nor yet the catechism, that worked so great a reformation among the children of the pin-makers of Gloucester. It is my belief that the teaching of the multiplication table would have been beneficial if it had been seasoned with the kind words and Christian solicitude of the genial patron and his shilling-a-day Sunday-school-mistresses. Unto this day many of the followers of Raikes have failed to learn that men are regenerated, not so much by truth in the abstract, as by the divine inspiration that comes through human goodness and sympathy. The great Bible of childhood, especially, is the living Bible of good and loving men and women.

Raikes may have heard of previous attempts of the kind, but it hardly seems probable. If there were any Sunday-schools in England or Scotland at that day, they were obscure and unrecognized beyond their immediate sphere of influence. There is nothing new under the sun. Something like Raikes's school often had been attempted before, and the pedantic people who can always tell you the history of a thing before its beginning, and who love to dim the glory of an original by pointing to an earlier origin, have cackled not a little over Martin Luther's school in 1527, Cardinal Borromeo's schools in 1584, Joseph Alleine's in the seventeenth century, and Oberlin's Sunday teaching in the Ban de la Roche in 1767. The Methodists and the English Church people both claim and divide the credit of Miss Hannah Ball's Sunday-school in High Wycombe, in 1769, while the Scotch Presbyterians prove that

Sunday-schools, in common with most other good things, came from John Knox, who employed readers to teach on Sundays; and indeed it seems pretty certain that some such schools existed in Scotland before Raikes's. So, also, there were isolated Sunday-schools in this country a hundred years before Raikes, and I doubt not something of the sort has existed in every age in which there was religious activity. Indeed, there are not wanting ingenious people who trace the institution to the Church Fathers and the Jewish Synagogue. The ancients had the start of us in chronology. But it matters not, even though one could prove that there were isolated efforts to found something like Sunday-schools among the people who were contemporaneous with the hairy elephant and the cave bear,—it is the one attempt that grows and bears fruit which signifies. Of a million seeds with gossamer wings that drift away from a cottonwood-tree, sailing on the wind, or floating on the water, only one lodges by chance in some favorable nook, and grows a tree after its kind. And of all the Sunday-schools founded in modern or remote times, the one set agoing by the Gloucester newspaper man was the only one that, lighting on a favorable time, multiplied and grew into a great institution. The others saw no centennial and had no posterity.

I ought, perhaps, to except from this remark St. Charles Borromeo's Sunday-schools in Milan. In 1877 I saw the poor boys gathered in the magnificent cathedral of Milan, with copy-books and slates before them, learning in the Sunday-schools that are yet kept alive by the precious memory of San Carlo. When the lessons had been laid aside energetic priests addressed the children with dramatic earnestness; and in another quarter, and by other priests, workmen were being instructed. There are more than four thousand statues on the pinnacles and in the niches of this great *duomo*, if you may believe the guide-books, and the sacred bones of St. Charles, the great archbishop, are shown with much ostentation; but the best memorial of his great influence is that, three hundred years after his time the poor of Milan are taught the three R's, with the fourth one of religion added, in the sacred temple and on Sunday. It is in the very spirit of Charles Borromeo himself, and of one who was Borromeo's master and model, that his successors recognize the fact that cathedrals and Sabbaths are for the use of the souls of men, which are more sacred

than holy places, holy days, holy vestments, or holy bones.

Indeed it is the veneration for holy bones and holy days that is always resisting a good movement. The innovating and reforming cardinal archbishop of Milan was so thoroughly hated by some of the members of religious orders that they tried to shoot him. No doubt he was held to be a desecrator of the Sabbath, the sanctuary, and the priesthood. Certain it is that Raikes was met by a pious wail about the sin of teaching children to read on the Lord's Day. Better that the pin-makers' children remain in vice and ignorance, than that the Lord's day be used in doing the Lord's divine work! And to-day, if any man tries to do Sunday-school work in that broad and large way which embraces the whole life of the child, and which is the only practical and successful way of doing the work as Christ did it, he is met with denunciations. Let him, for instance, try to stem the tide of evil literature by giving good, healthy, secular books from his library, or let him try to conquer vagrancy by having an employment committee in his school, and immediately the protectors of the Sabbath and the defenders of Scripture study are aroused. For the Pharisees have never yet wanted a man to stand before the Lord in any generation. Brethren of the Holy Bones, will your obstructive race never be extinct?

It seems, in the light of better methods, but a poor attempt, that of hiring women at a shilling a Sunday to teach these poor children, of the hemp and flax factory and the pin factory, reading and the catechism. It was but little reading, perhaps, that one could get in a lesson a week, and catechisms are quite dry and indigestible food, fit only for theological students. But Raikes's school had that which is the most valuable element of all the best schools of the present day—genuine love for childhood on the part of the teachers. The catechism might be incomprehensible, but the love of the good Mr. Raikes and the personal influence of the patron and his teachers were a blessing of infinite value to the degraded children. Raikes loved the children and took an intense interest in them. He called his work "botanizing human nature." Once he endeavored to persuade a refractory girl to beg her mother's pardon, which she steadily refused to do. "Then," said Raikes, "I will make a beginning for you," and down upon his knees he went and began to crave the mother's pardon, whereupon the heart of the girl

gave way. Do you think it mattered much whether such a man taught the catechism or the International Lessons? Doubtless, in this year of celebration, many a prig who prides himself on chalk and blackboard and object-lessons and lesson-helps, but who knows nothing of heart-winning, will talk very patronizingly of Raikes and very boastfully of our "progress." Without doubt we are far ahead of the Gloucester printer in methods of organization and the matter and manner of teaching; but much that goes for progress is the merest pinchbeck imitation, and many who run after method forget the real end of their work.

I dwell thus on Raikes, because he had so clear an idea of some vital things which are forgotten by many who nowadays prophesy in his name. He welcomed the poor, while many of our uppish schools practically exclude them. He only required clean hands and face. He knew that he who would improve a child's spiritual condition must look to his circumstances, and so he sought employment for his Sunday-school children and looked after their home life. And yet, we are gravely told by the doctrinaires who write his biography, that in the beginning of all this good work he was yet unconverted! Many a worthless religious loungee has had an "experience"; but we are told that this man, who was too much of a Christian to worry about his own soul, was without divine grace. How do biographers try to make us believe that religion is of no account! For the Pharisee, whose ancestor stoned the prophet for working on Sunday, comes round after a while and garnishes his tomb and writes his "memoir," and tries his best endeavor to make the life, which grew large and free after God's own law, fit his circumscribed theory. But the full-grown forest tree will not bear transplanting into a door-yard.

Many a superintendent or teacher, with great religious confidence in himself, and with all the implements which the progress of later times has given him, might well sit at the feet of this unregenerate Robert Raikes, who lived in those old-fogy times of a hundred years ago. Hear what he says: "I have often, too, the satisfaction of receiving thanks from parents for the reformation they perceive in their children." Through what? Not through an elaborate seven years' lesson system sampling the whole Bible, for that they had not. Not through the spelling, the reading, or the catechism, I suppose. One might as well try to

warm his hands by an iceberg as to expect any reformation of heart or life through the dry formulas of a catechism. Raikes's "little heathen" were reformed by the "method" that never grows old, and on which the most inventive Sunday-school worker has never yet made any improvement. "Often," he says, "I have given them kind admonitions, which I always do in the mildest and gentlest manner. The going among them, doing them little kindnesses, distributing trifling rewards, and ingratiating myself with them, I hear, have given me an ascendancy greater than I ever could have imagined; for I am told by their mistresses that they are very much afraid of my displeasure." Here is the admirable method of working by a loving sympathy in the hearts of men; Raikes had not heard any of our lectures to teachers, or read any of the books we have written. His plan, however, is as old as Christianity, at least.

"Ere Locke or Newton came, the sun
Saw things by heart and genius done,
Which those great men have proved in viewing,
The possibility of doing."

Let me not be misunderstood as decrying the advancement made in Sunday-school work. The improvement of introducing voluntary teachers, and the other one of replacing the catechism with the Bible, saved the system from becoming utterly dry, perfunctory, and worthless. One of the greatest benefits conferred by the Sunday-school consists in its having furnished the readiest means for unselfish exertion to millions of people. It would be difficult to estimate its influence on religion in this country. It seems to me that it is the one thing that has kept church-life from congealing into a hopeless social and dogmatic exclusiveness, or sinking into indifferentism; there has always been an outlet for Christian sympathy and an opportunity for religious zeal in the instruction of the young.

Make what reduction you will, and the result of Raikes's attempt is an incalculable blessing. Estimate the Bible at the lowest, and its study by so many millions of children must have done much to ensure, to America, for instance, that moral superiority which makes life here so much sweeter than on the European continent. Is it nothing that for some generations the Sunday-school has made the beatitudes, the Lord's Prayer, the immortal parables, and the death of Christ, the most familiar of household words? One would think that even so fiery a des-

tructive as Mr. Ingersoll could not estimate lightly the influence of such a service. Grant all the imperfections of method and all the mistakes as regards matter, and yet the influence of such schools must have been prodigious in checking such a vice as intemperance, for instance. And even if we put the subject of teaching out of account, the very institution, on a religious ground, of such a friendly relation as that of teacher and scholar, cannot but have been of inestimable benefit to individuals and to society. Raikes himself—to return once more to the founder—looked at his work from a two-fold stand-point, that of religion and that of philanthropy. He calls the Sunday-school "an effort at civilization," and says, in the phrase of the time, that "if the glory of God be promoted in any, even the smallest, degree, society must reap some benefit."

It is too much to ask that the teaching in Sunday-school be conducted according to scientific method. The teachers are busy people, mere amateurs in the art of conveying instruction, and, on some accounts, all the better for it. Some will insist that these teachers shall give instruction according to the science of pedagogy, as now understood. It was gravely proposed, ten years ago, by men of considerable standing in the Sunday-school work, to organize a normal Sunday-school college in New York City, to which teachers should be brought and instructed in a six months' course. The transportation to New York of half a million busy men and women, and their sojourn here for six months, was found to be a very serious enterprise. The excellent plan hit upon by Doctor Vincent of transforming the obsolescent camp-meeting into a summer Sunday-school assembly, which should combine pleasure and instruction in about equal parts, has proved to be far more feasible, and, indeed, seems to be the most practical method of giving a Sunday-school teacher some knowledge of method. The dangers of this plan are manifest. What with Palestine parks and Jerusalem models, and lath and plaster pyramids, and oriental costumes—all good things to draw crowds—the teacher is apt to forget how slight, after all, are the relations of geography and antiquities to the substantial work in hand. He may add not a little to the vividness of his teaching by means of the outer settings of Scripture narrative, but to make the giving of this sort of knowledge an object is hopelessly to lose his way. The geography of Palestine has no direct

relation to the betterment of character, and the costume of an oriental, or even of a high priest, is in itself no more religious than the costume of a Scotch highlander.

This failure to appreciate the true object of Sunday-school work lies at the bottom of most of the vices of our Sunday-school system. With that nominalism which is the easy snare of most men, Sunday-school people are generally confounded by the unfortunate word *school* in the title of the institution. Hence the visionary, and happily futile, attempts at a grading analogous to that of the common school; hence the system of review examinations; and hence the deeper and more vital error, which makes the chief measure of success to be the quantity of information retained by the pupil. This is a common and capital mistake in secular education, and it is even more fatal when introduced into the spiritual training of children. For the religious teacher there is no result worth the having but a result in character. All instruction, Scriptural or other, that tends to produce moral or spiritual improvement, is in his province, and none that does not. I should be the last to insist that the teacher might not roam widely over any part of the field of knowledge for the purpose of interesting and gaining the sympathy of his pupils, provided he kept his main end in view. But he should not feel obliged to teach anything merely because it is in the Bible or has relations to Scripture history. The tendency is to insist on a practical bibliolatry, on the teaching of the Bible as an end, on the theory that man was made to study the Bible, and not the Bible for the benefit of man.

I remember a Sunday school teacher of my own boyhood, a man who combined the offices of village butcher and lay preacher, and who had a stern way of teaching us Scripture; he made us take the Bible as the Jews ate the passover, with bitter herbs. It was the custom in that day to read an entire chapter for a lesson. One Sunday we found ourselves confronting the genealogies in Luke's gospel. Somewhere in the hard names between "Mattathias which was the son of Amos," and "Ragau which was the son of Phalec," one of us ventured to ask the hard-headed teacher if we might not skip that chapter. "What did the Holy Ghost put it there for if it is not to be read?" he growled. The logic was unanswerable, and so was the tone; we floundered on through the "bead-roll of unbaptized names" until we joyfully reached "Adam, which

was the Son of God," with a sense of having come out in paradise at last. Some such unanswerable theory as that of my old teacher seems to have been at the basis of the present International Lesson scheme. On no more rational supposition can one account for the compulsion put upon little children a few years ago to wander through the five books of Moses under the lead of the lesson committee, studying the tower of Babel, the plagues of Egypt, the institution of the passover, and the founding of the Levitical priesthood. These subjects, and such recent assignments as the second temple and its dedication, carried through two lessons, Ezekiel's prophecy against Tyre, and Esther's marriage to the polygamous Xerxes, are not given to adult classes alone, but, by the unpractical idealism prevalent in Sunday-school work, are set down to be taught even to infant classes. It is all Bible, but there is one other thing as divine in its origin as the Bible, and that is common sense. And surely the present system of rigid adherence to one lesson for all the school, combined with the selection now and then of subjects fit only for a theological seminary, is not in accordance with practical wisdom.

One hears much of the Christian unity produced by the simultaneous study of the same lesson by people of different religious denominations, but as each denomination publishes its own lesson and has the privilege of putting its own construction on the text, the practical result in favor of Christian toleration and unity does not seem to be large enough to overbalance the disadvantages. One of these is, that in Scripture selections it is Hobson's choice or nothing. The mission-school in the Fourth Ward, among children who do not know the rudiments of religious teaching, if it will avail itself of current printed helps, must study the Book of Revelation at the same time with the church-school in Madison avenue. The floundering teachers in the mission-school are supposed to be happy, however, in the consciousness that they are serving the cause of Christian union, for are not the children in Toronto, and perhaps in Hong Kong, reciting the same lesson? I do not think I am too severe when I call this unpractical idealism, though I know, to my cost, the awful result of assailing the great goddess Diana whom Ephesus and all the world worshipeth. Whatever toleration an international system of lessons produces, it does not bring forth among its advocates

any particular forbearance toward the man who opposes the scheme.

But the system has produced one good result, which I have never heard urged in its behalf, but which is the most evident benefit of the present plan. There were always a large number of schools out of sympathy with any progressive movement, stranded on the sand-bars of their own fogyism. The almost universal introduction of periodical lessons, which followed the adoption of an international course, and its sanction by ecclesiastical bodies and denominational publishing houses, has tended to introduce some Sunday-school periodical or other into each of these schools, and to awaken the teachers to the fact that there are far better ways of doing than those of the fathers. The past twenty-five years has been a period of great improvement in methods of conducting schools and classes, and the periodical lesson has been a conductor and distributor of the new and better ways. It has given the leaders of Sunday-school thought a compact power over all the schools, and this is, in the main, an advantage. But it has almost stamped out the individuality of the foremost schools, and given undue prominence to certain popular ideas and watchwords. The time draws near already when this wide-spread monotony of text and plan must give way; when the thoughtful and vigorous superintendent will devise ways suited to his own genius and his own school and when the adult class under a learned teacher, the infant class under a skillful teacher, and the mission class peculiarly situated, will each feel free to follow its own best road.

A good officer is ordered to take a battery—he is not told precisely how to take it. Some such liberty should be given to the teacher or superintendent who is peculiarly situated, or who has a peculiar genius. For the great mass of teachers uniformity in the school may be necessary, but a rigid and invariable uniformity in each school, and still more in thousands of schools, is a great evil. More and more, as we grow practical and yield to the divine common sense, will we understand that the substantial upbuilding of noble character is the result to be achieved, by such hook and crook as lies within our reach. One of the best teachers of mission children I have ever known, took a class of almost incorrigible bummers, who frequented the school only about festival time, and devoted himself for Sunday after Sunday, to telling them the story of Robin

son Crusoe's adventures. By the time he had finished his serial story, he had acquired, by one means and another, a singular ascendancy over his boys, some of whom were street-venders and wanderers. If he had not let go of the uniform lessons he would have lost his pupils in three weeks. Such achievements as his, in bettering the lives of the neglected, are "Bible stories" in themselves.

In our Sunday-school institutes and conventions, and in our normal classes and teacher's periodicals, we debate all manner of questions of organizing and teaching. But the philanthropic use of the institution, ever present to the mind of Raikes, is almost forgotten. How to use a blackboard, and how to question a class, and how to teach doctrines, and what is the "relation" of the Sunday-school to the church, are often discussed. But where has the question, of the mode of decreasing pauperism through Sunday-school work, ever attracted any attention? What have Sunday-school people done to promote the acquisition of skill in handicraft by Sunday-school children? On the other hand, many a boy, by the atmosphere of false gentility diffused by some Sunday-schools, has been led to seek a well-dressed employment, for which he was unfit, to the lifelong undoing of himself and those dependent on him. The veneering a boy with a thin respectability of hat, coat, and cane, is often the only apparent result of his attendance on Sunday-school, and it is an evil result. Let once the questions of "sacred" geography and antiquities give way to questions of practical life in Sunday-school work, and there will be less vagrancy in America. For the Sunday-school is one of the powerful formative forces in our life, and that force is sometimes perverted, and sometimes, even, tends to a genteel vagrancy.

There are some schools that watch over the lives of their scholars, see to their attendance on day-schools and night-schools, seek out situations for them, and strive to instill into them a hatred of dependence and a respect for work and thrift. But there are many schools where the teachers and scholars vie with each other in dress, vanity, and flirtation. We debate whether a teacher shall be "converted" or not, and we miss the real point. A professor of religion may be a coxcomb or a coquette. Nor will discrimination against young teachers do any good. There are old fools, also. To get earnest teachers is the chief thing, and to

have none other, if possible, is the fundamental maxim.

It is this frivolous spirit that makes vain much of the effort put forth in the right direction. In our time it is vitally necessary to promote a sturdy sentiment in favor of abstinence from intoxicants. The vice of intemperance is not one that you can trifle with. But of what avail is the easy signing of a temperance pledge by a school full of impressible children. Temperance, like any other virtue, must be taught with painstaking, and the lesson must be impressed by patient instruction. It is not a virtue, either, that will stand by itself; the whole moral nature must be fortified. The true antidote to intemperance is a Christian manhood. But a thin gentility, that abhors manual labor and affects stylish dress, is something not friendly to the growth of manhood, and that is, moreover, often disastrously fatal to womanhood.

It is generally admitted now that our cheap literature is, much of it, bad. But what have we done through Sunday-schools to stem the tide of evil? We have sought anxiously to teach the story of the plagues of Egypt, but we have forgotten the frogs and lice and locusts of the news-stand. We have been so careful to keep the Sabbath holy that we have excluded all but semi-religious stories from our libraries. These stories are, of necessity, for the most part of a very watery intellectual consistency, and it has been easy to pass from them to the equally weak, but far more exciting, story-paper. The general uselessness of most Sunday-school libraries has brought about a movement, not to improve them, but to abolish them. No better illustration of the absolute failure of a part of the Sunday-school public to understand the philanthropic possibilities of its work can be found than the stampede against libraries and in favor of that weakest of literature, the Sunday-school juvenile paper.

To put the library out is to abandon the field. By means of the Sunday-school the religious community controls, at the least, fifty thousand circulating libraries in America, and these libraries are read chiefly by children and young people. Through them the Christian church ought to be able to make the literary tastes of the next generation morally healthful and intellectually better. But, in the first place, the church impairs the tone of public taste through a foolish scruple, and then is offered by some good people only the alternative of abandoning the powerful

engine of the Sunday-school library altogether. Some of the best of our metropolitan schools, notably the mission-schools of Mr. Beecher's and Dr. Storrs's churches, have looked the matter square in the face, and have put the healthiest and most attractive reading of other than a religious nature on their shelves. The stories and pictures of the children's magazines, and the best books for boys and girls, now go out into the poorest home. If this reform should become general, we may hope for a substantial improvement in the reading of young people.

But I dare not say too much on this matter of giving healthy books on Sunday. The frown already darkens the brows of the Brethren of the Holy Bones. Let me swiftly take shelter behind the dignified form of Robert Raikes, of Gloucester. "Our Savior," says Raikes, taking refuge himself behind a higher example, "takes particular pains to manifest, that whatever tended to promote the health and happiness of our fellow-creatures were sacrifices peculiarly acceptable on that day."

I am sure no one will suspect me of unfriendliness to the Sunday-school in making these criticisms upon bad methods. There will be enough of praise lavished on the institution in this centennial year. But indiscriminate praise of the Sunday-school by Sunday-school teachers is only a sort of self-glorification, and progress is always hindered by a Fourth-of-July boastfulness. We have made great advancement, and the current seems to set in the right direction. Our joyous festivals, our Christmas-trees, our entertainments, are all signs of a genuine sympathy for the joys of childhood. Campbell's line,

"The playmate ere the tutor of her mind,"

suggests one of the highest principles of child-training.

No one knows better than I, from long and large acquaintance with Sunday-school people in this country, the faithfulness and self-denial of thousands of them. The faults of the work belong primarily to certain forms of religious life, now passing away, let us hope. There has been too much other-worldliness in our thinking for us to work with practical wisdom. We have cared too much for soul-saving in a narrow sense, and not enough for character-building in a wide sense. It has been well said that the world loses as much by misdirected effort as by idleness. And, rejoicing as we do in the results achieved, let us not blink

the fact that probably one-half the effort put forth in Sunday-school work is wasted, and some of it worse than wasted.

Too much attention to questions of dogmatic belief, and too little to questions of conduct; too much bondage to the teaching of the Bible and related subjects as an end, and too little devotion to the production of Christian character; too much superficial and revivalistic work, and too little broad philanthropic endeavor; too much frivolity and perfunctory lesson-hearing, and too little of the affectionate, life-long attachment of god-parent and god-child between teacher and pupil; too much system and

too little freedom and common-sense; too much memory and too little sympathy—these criticisms can justly be made against much of our Sunday-school work in the hundredth year after Robert Raikes of Gloucester.

The time will come and the leader will come. He will teach us as Jesus taught, that the Book, and the day of rest, and the creed symbol, are all subordinate to the welfare of the human spirit, and that practical endeavor, if it will achieve its best result, must disentangle itself from theoretic idealism, and from bondage to dogmatism, tradition, and convention.

EDISON'S ELECTRIC LIGHT.

BY FRANCIS R. UPTON (MR. EDISON'S MATHEMATICIAN).

EDITOR SCRIBNER'S MONTHLY.

Dear Sir: I have read the paper by Mr. Francis Upton, and it is the first correct and authoritative account of my invention of the Electric Light.

Menlo Park, N. J.

Yours Truly, THOMAS A. EDISON.

THE crowning discovery of Mr. Edison—the electric light for domestic use—is at last a scientific and practical success. A mistaken idea has been afloat that this new light was intended to be a rival of the sun, rather than what it really is,—a rival of gas. The contrivances of the new lamp are so absurdly simple as to seem almost an anticlimax to the laborious process of investigation by which they were reached. A small glass globe from which the air has been exhausted, two platinum wires, a bit of charred paper—and we have the lamp. The generator of the electricity is simpler than a gas-generator, and the wires for its distribution are more manageable than are gas mains and pipes. The light is equal to gas in brightness and whiter in color; it is inclosed and, consequently, perfectly steady; it gives off no appreciable heat; it consumes no oxygen; it yields up no noxious gases, and, finally, it costs less than gas. The difficulty of subdivision Mr. Edison has also overcome: in his method of illumination a number of separate lights can now be supplied from the same wire, and each one, being independent, can be lighted or extinguished without affecting those near it.

In order to a clear comprehension of the electric light, a few words upon the general subject are necessary. All illuminants are produced by the incandescence or white heat of matter. This matter may either be in a

finely-divided state—the particles widely separated—as in the flame of candles, lamps and gas-jets, or an aggregation of particles, as in the calcium light. Both of these methods have been used in the various systems of electric lighting. Electricity flowing through a conductor generates a quantity of heat proportioned 1, to the amount passing through, and 2, to the friction, or resistance, of the medium. Ordinarily, the amount is hardly appreciable in a good conductor. When, however, a poor conductor forms part of the electric circuit, a heat is generated that, under certain conditions, rises steadily to whiteness, causing the substance forming the imperfect conductor to become luminous. If the wire of an electric circuit be cut and the two ends, after being touched, are drawn slightly apart, the current leaps the chasm and a spark appears which vaporizes a small portion of the metal, and this forms a sufficient conductor to enable a constant electrical current to flow from end to end of the wire. When the two ends of the severed wire are properly tipped, a continuous and brilliant light may be produced. Carbon is found to be the best material for these tips, and so long as the current flows and the distance between the points is properly regulated, a storm of white-hot carbon particles is carried across the space, giving a brilliant illumination. This is the voltaic arc, a light produced by the incandescence of finely-

divided matter. The broken circuit may be completed by the interposition of some solid matter capable of sustaining a white heat without melting. Platinum and carbon were long thought to be the forms of matter which would best answer the purpose.

These methods of utilizing electricity presented so many difficulties that it was thought impossible to use either for domestic purposes. The objections to the voltaic arc were that the carbon did not offer sufficient resistance to the passage of the current, and that it wasted, the light therefore requiring either continual attention, or else some complicated mechanism, both troublesome and expensive, to keep the distance between the carbon points constant. (See Fig. 3.) The objections to platinum lay in its great cost and rarity, and the fact that its point of fusion is too low to ensure its successful use as the source of light. And finally the objection to all known methods was that the conductors necessary to the supply of any lamp then known would have been of such enormous cost and size as to be impracticable for general use.

In order to understand the difficulties of the problem presented to Mr. Edison, and the simple perfection of his lamp, a short summary of the history of the electric light will be necessary. The first method of illuminating by electricity was by the voltaic arc. About twenty years after the discovery of galvanism, or the modes of generating electricity by chemical decomposition, the voltaic arc was discovered by Sir Humphrey Davy. The battery of a single cell was succeeded by those of multiplied power. In 1812, by the use of a battery of 2,000 cells, Davy succeeded in producing an intensely brilliant arc measuring five inches. The experiment was, however, a very costly one, and had apparently no practical outcome; yet the effects produced by it were so brilliant that Professor Dumas, who repeated it in Paris, in 1834, predicted its final success as an illuminant, in spite of the enormous cost—six dollars a minute. For a number of years no improvement was made, the batteries then in existence being incapable of supplying a constant and steady flow of electricity. Daniell's invention in 1836 of a constant battery, used still in telegraphy, and Grove's improvement in 1839, of electrical generators, gave a new impulse to inventors. A constant and powerful current being supplied by these two inventions, the practical use of it was shortly afterward made in Morse's tele-

graph. In 1845, about the same time, we find that the first mechanisms for regulating the distance between the carbon points were independently invented by Staite and Foucault, who thus in another direction utilized the electrical power supplied by the batteries. Staite's patents show great inventive genius; in one of them there is a well-defined suggestion of the widely known Jablochhoff candles. In this field of research, as in so many others, the earlier investigators possessed a clearness of vision which enabled them to see further and more accurately than those who came after. Staite, before 1850, produced an electric light, which was exhibited in England, and was so favorably received that a company was organized and gas stock suffered a panic. Many other inventions were made, with a vast expenditure of time, ingenuity and patience, which, like those of Staite and Foucault, failed because of their great cost. It is not enough to invent a good light, nor even to perfect its mechanism: the cost of production must be small enough to enable it to compete with all existing methods of illuminating.

Electric lighting had now passed through three stages. It had been a brilliant laboratory experiment, it had been the subject of practical investigation, and it had been advanced to the precarious dignity of occasional use in the theaters and on great festival occasions. At the coronation of Alexander of Russia, the city of Moscow was lighted by numbers of electric lamps suspended in the old bell-tower of the Kremlin, a thousand gilded domes glittering in the unearthly radiance, in happy contrast with the quaint arches of the old cathedral close at hand, while the river Moskva was transmuted into a stream of liquid silver.

The year 1860 saw improvements in generators. The force of steam was found to be convertible into electricity. In 1862 Faraday introduced the electric lamp into a British light-house. France and Brazil tried the same experiment, but even this failed to arouse public interest. The invention of the Gramme generator (though an instrument fully anticipating it had been lying for years in the cabinet of an Italian university) at last gave the impetus needed to set the inventors at work. This was soon followed by the Jablochhoff candles, the contrivance by which some streets in Paris are illuminated. So much for the history of illumination by the voltaic arc.

In 1845, to go back to the second method,—that of illuminating by an incandescent solid,—an American named Starr, backed by

George Peabody, went to England, and took out a patent for the use of platinum, which had been already employed in laboratory experiments, although it had never been used for practical purposes. In the same year Grove speaks of reading by an incandescent platinum spiral.

In 1847, Dr. Draper, of New York, made a number of experiments to test the qualities of highly heated platinum. He used a lever suspended by a straight wire, very much resembling a door-latch held by a string. So marked was the illumination from, and the expansion of, the heated wire at the temperature required for the experiment that he wrote: "An ingenious artist would have very little difficulty, by taking advantage of the movement of the lever, in making a self-acting apparatus in which the platinum wire should be maintained at uniform temperature, notwithstanding any change taking place in the voltaic current." This suggestion, though so clear and practical, lay for twenty years unheeded, and would probably have done so much longer, but that Mr. Edison, with no knowledge of it, entirely independently made use of a similar device and proved himself to be the "ingenious artist," in his first electric light invention.

Fig. 1 shows the plan of the apparatus.*

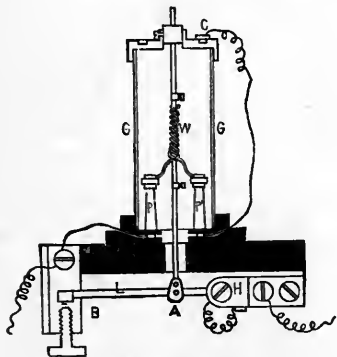

FIG. 1. SECTION OF EDISON'S EXPANSION REGULATOR.

The current enters through the curled wire at the left, and flows from one post, P, to the other, P', through a spiral and out at the right. It is carried to the top of the glass case, G, then through the straight wire, W, to the lever at A, then to the hinge, H, so that it escapes at the right. In passing through the straight piece of platinum wire, W, enclosed in the spiral the heat generated by the current causes the wire to expand. This expansion allows the lever, L, to fall until it

* The portions marked black in the cuts are insulated.

touches the point, B. When this is done the electricity takes the short route through the lever and does not pass through the lamp. The wire, W, contracts and the process is repeated.

Another method of accomplishing the same purpose is shown in Fig. 2. The current passes, in this case, through the wire, W. In so doing it heats the air in G. The air

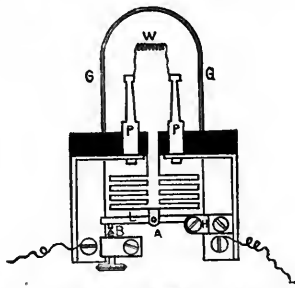

FIG. 2. EDISON'S PNEUMATIC REGULATOR.

in expanding forces downward the small metal bellows which is connected with the chamber, until the lever attached below closes the break, B, and short circuits the lamp, allowing the air to cool. These two inventions really belong to the infancy of electric lighting, though invented by Mr. Edison only a short time ago.

In 1849 Despretz describes a series of experiments on sticks of incandescent carbon which were sealed in a glass globe, the air being exhausted, or nitrogen substituted for it. He used several ingenious methods for holding the carbon—patented within the last few years.

So completely had the mode of lighting by an incandescent solid been forgotten, that in 1873 a medal was bestowed by the St. Petersburg Academy on Lodyguine for its supposed discovery, and letters-patent were granted to Sawyer and Mann for a stick of carbon rendered incandescent in nitrogen. No successful light by incandescence had, however, been produced when Mr. Edison began his experiments.

In 1878 the lighting of Paris by the Jablochkoff candles was creating a great stir. It had been proved that electricity was really a rival of gas, and that, especially where great concentration was needed, it could take its place. The question now was whether light could be produced in such small amounts as to make it of general domestic use. The money value of an invention which could compete with gas may be judged from the following items: The United States has \$400,000,000 in-

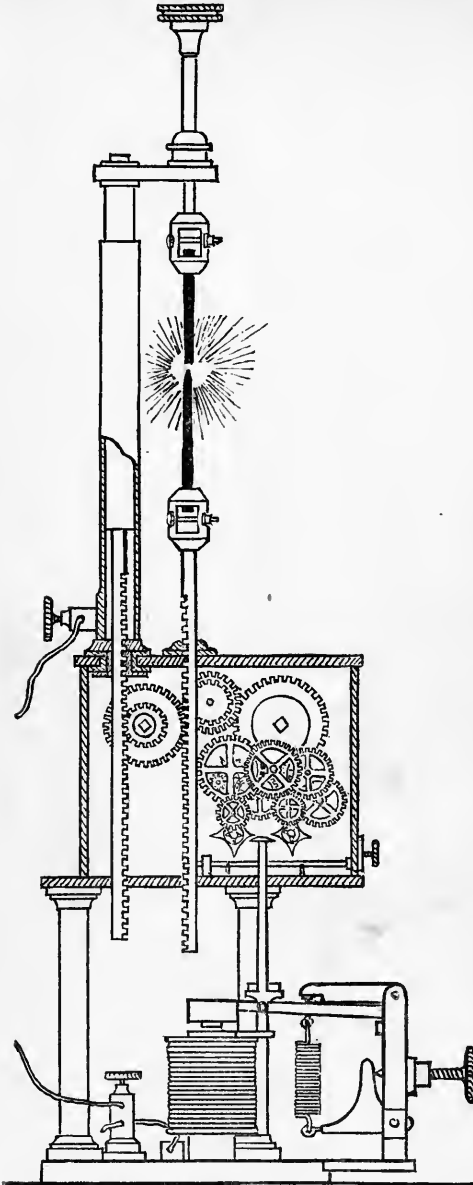

FIG. 3. FOUCAULT'S REGULATOR.

vested in gas, New York and the vicinity owning about \$35,000,000 of this; England has \$500,000,000, \$60,000,000 of which is in London. Paris has \$40,000,000; Germany \$50,000,000, etc. Capitalists, with these figures before them, and the further fact that notwithstanding the great depreciation in plant, the larger portion of this enormous capital was drawing ten per cent., were quick to see an opening for their money and enterprise. Several New York gentlemen, Mr. Grosvenor P. Lowrey and members of the

eminent banking-house of Drexel, Morgan & Co. being the most prominent, placed \$100,000 in cash at Mr. Edison's disposal, as the requisite means to make the research.

Mr. Edison came to the investigation unhampered by the blunders of his predecessors. He had never seen an electric light. He took hold of the subject in his usual clear-headed, practical way. Next to solving a problem, its intelligent statement is to an investigator the most important thing. Mr. Edison saw that permanence in the lamp and a subdivision of the light were the main things to be sought after. Of the two methods already described, he soon discarded the carbon arc. He perceived that from its nature this arc was inconstant, as its very existence depended upon the destruction of the carbon, and also that it presented greater difficulties in the way of subdivision. Even if he succeeded in conquering the latter difficulty, and was enabled to produce small lights, the carbon rods waste so rapidly that a system of such lamps would require an expert for every four or five houses to keep it in working order. The most effective apparatus then devised was Foucault's regulator, Fig. 3, which it will be seen is a very complicated piece of mechanism. The Jablochhoff candles, simple as they appear to be, require mechanical contrivances to light them and keep them burning, each candle lasting only a few hours, which makes the constant expense for new burners more than that of the electricity which they can utilize. Mr. Edison, therefore, concentrated his attention wholly upon the light from an incandescent solid.

The advantages of subdivision are twofold and may be explained in a few words. To show that a good gas jet or German student's lamp gives, near the source of light, all the illumination necessary for ordinary domestic purposes, a simple experiment may be tried. A printed page directly under the light, will be seen to be brightly illuminated. After carefully noting this, let another equally strong light be kindled. The room will be brighter, but the page will appear to be scarcely brighter. This is because beyond a certain limit the eye becomes insensible to light. One therefore gains nothing for ordinary use from a single intensely brilliant light. The object of such an illumination being of course to bring, by means of several moderate lights, all parts of the room up to that point where the eye, before it begins to be numb, can utilize the light. This explains the first advantage of subdivision;

the second is of another kind. Every one familiar with the electric light, as it has been exhibited, knows that the intense brilliancy of the light and the sharp definition of the shadows, as well as their depth, makes it most trying to the eyes. The same amount of light distributed among a number of burners would not give more illumi-



FIG. 4. EFFECT OF CARBON ARC ILLUMINATION.

nation, but it would be of more practical value, the light would be more diffused, the contrast between light and shadow less sharp and startling. Fig. 4 shows the effect of a shadow from a single brilliant carbon light, and Fig. 5 the effect from several shaded lights; the advantage of the latter for practical and domestic use will be readily seen. This is equally true with other illuminators; though gas may be made to give out a brighter



FIG. 5. EFFECT OF GENERAL ILLUMINATION.

illumination per cubic foot when burned in a concentrated form, it is yet more grateful to the eye and less trying when burned as a number of small lights, so that sharp contrast shall be avoided. It is also found that the shape and size of flame, apart from the quantity of light emitted, makes a great difference in this respect—a large light soften-

ing the edges of the shadows. The shading of a light, although it obstructs illumination, is useful in diffusing it.

As has been said, Mr. Edison came to the subject unhampered. He saw that subdivision was his goal, and toward that he steadily worked. With a steadfast faith in the fullness of Nature, a profound conviction that, if a new substance were demanded for the carrying out of some beneficial project, that substance need only be sought for, he set to work. Two examples of the reward of his faith may be mentioned. One of the great difficulties in the way of illuminating by an incandescent solid—a difficulty constantly urged as insuperable—was that platinum, though the most infusible material which could be drawn out into a wire, still melted at a temperature too low to insure its successful use. Mr. Edison, by experimenting, found that by slowly raising a piece of platinum to a white heat in a vacuum, he could make a practically new metal, the fusing-point was so greatly raised. Again, Mr. Preece, chief government electrician in England, declared, and was sustained by many others, that subdivision of the electric light was impossible, because of the enormous size of the conductors and the number of Faradic generators necessary. Edison simply introduced into his lamp an increase of friction or resistance to the electric flow, and the problem was solved.

Mr. Edison's idea in regard to the electric light was that, in all respects, it should take the place of gas. Following the analogy of water, the inventor conceived of a system which should resemble the Holly water works. As the water is pumped directly into pipes which convey it under pressure to the point where it is to be used, so the electricity is to be forced into the wires and delivered under pressure at its destination. In the case of water, after being used, it flows away by means of a sewer-pipe, and is lost. But it is easy to imagine that the water used in working machinery, for instance, instead of being lost, might be returned to the pumps and used over and over again. With such a system as this, we should have a perfect analogy to the Edison electric lighting system. The electricity, after being distributed under pressure and used, is returned to the central station. As the light results from no consumption of a material, but is mere transmutation of the energy exerted in the pumping process, it is therefore seen that all which is essential to an electric lighting system is the generator (or

pump), the two lines of wire, one distributing the electricity, the other bringing it back, and a lamp which transmutes into light the energy carried by the electricity when it passes from one wire to the other, and in which the energy of the pressure expresses itself as the light. In Edison's invention the amount of electricity delivered in the lamp is determined by the size and resistance in the carbon, just as in water the amount of flow is determined by the size of the openings. As a great many small jets of water can be supplied from one pipe, so a great many lamps or small escapes for electricity can be furnished from one wire.

As in the case of water, the amount of work done by electricity—either as illuminant or motor—is dependent quite as much upon the pressure from which it escapes as upon the quantity passing through the wires. We might have a system of lamps which would give a certain amount of light from large quantities of electricity escaping under low pressure, or another system which could give an equal amount of light from a small quantity of electricity escaping under high pressure. As in either case the amount of electricity flowing through a wire is in proportion to the size of the wire, it will be readily seen that the application of pressure made by Mr. Edison obviates the main difficulty in the way of subdivision (*i. e.*, in the way of the domestic use of the electric light), namely, the enormous size and cost of conductors. The well-known principle of the effect of pressure upon the dynamic power of electricity had never been utilized because the proper lamp was still unknown. This lamp is Mr. Edison's main discovery. In order to utilize this, one of the plans devised by him was to make the flow of electricity intermittent. Enough was allowed to escape in a short time, say one-third, to keep the lamp all the time supplied. It of course would require a large wire to furnish the quantity of electricity needed, yet two-thirds of the time the wire would be inactive, during which period it could be used to supply two other lamps constructed on the same principle. According to the doctrine of probabilities, one-third of a large number of lamps would be in use all the time. Such being the case, the cost of a conductor would be divided among three lamps. The lamps were so constructed as to burn steadily all the while, although the electricity was passing through them only one-third of the time.

One form of apparatus for accomplishing this distribution among several lamps on the same electrical circuit is shown in Fig. 6. The current conducted by a single wire enters the wire, O, from the lower left hand corner and flows through the spring, S, by way of B and B; upward through O', around the magnets, M, M, and out through the lamp. B, B, are two points where the circuit can be broken if the spring, S, is depressed. Two points are made in order that the spark caused by the breaking of the circuit may be made less by division. The spring S is de-

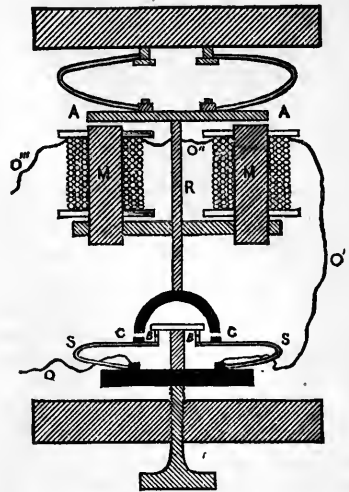

FIG. 6. EDISON'S VIBRATING REGULATOR.

pressed by the arms, C, C, which are attached to the armature, A, by the rod, R. The action is as follows: The current renders the magnet active, it attracts the armature, A, and presses the spring, S, under, stopping the flow of electricity by breaking the circuit at B B. The magnet thus losing its power, the armature is drawn back by the spring to which it is attached and the apparatus is ready to work again. The period of this vibration may be regulated by means of a screw underneath, which can make the excursion of the armature more or less before it breaks the circuit, or can even act to break the circuit itself.

In making an electric lamp which would be efficient without a regulator (as is Mr. Edison's later invention), two things are essential, great resistance in the wire, and a small radiating surface. Mr. Edison sought to combine these two essential conditions by using a considerable quantity of insulated platinum wire wound like thread on a spool. This arrangement is

shown in Fig. 7. The spool was made of zircon, pressed extremely hard, and was to be suspended in an exhausted glass bulb by two leading-wires.

The platinum, as has been incidentally mentioned, was hardened by alternate heating and cooling in *vacuo*, which is done by passing electricity through it till white heat is reached and then cutting it suddenly off. A theory is that the sudden cooling contracts the metal and squeezes out the air contained in it.

One of Mr. Edison's greatest difficulties was to get a substance with which to insulate his wires that would not melt and also become a conductor in the intense heat generated by the current,—in which case

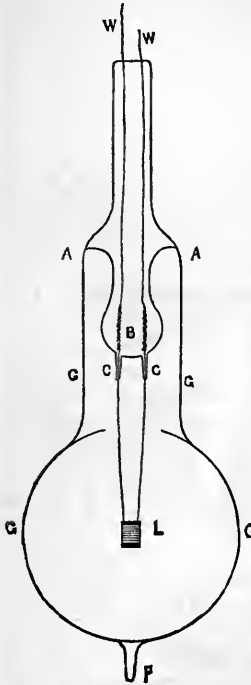

FIG. 7. EDISON'S PLATINUM LAMP. HALF SIZE.

the electrical flow instead of traversing the whole length of the wire would flow across from layer to layer, or sidewise from wire to wire. This difficulty diverted his attention from platinum to carbon, which is infusible. He did not suspect, at first, that it could be made to offer sufficient resistance to the passage of the electric current, and that through it he was to reach a happy solution of the entire problem. A long time was spent, with a fair degree of success, in seeking to make a spiral of lamp-black tar in the form of a wire. To hold this together he used a bit of ordinary sewing cotton which was covered with lamp-black, and succeeded in producing from an inch and a half of this simple thread, bent into an arch, a light equal to an ordinary gas-jet. The lamp-black, however, contained air, which greatly interfered with the success of the method. He then used a simple thread, which he found to answer the purpose, though it presented the objection of being fragile, uneven in texture, and unmanageable. This difficulty suggested the use of charred paper, cut into a thread-like form. The difficulties appar-

ently so insuperable melted away. The electric lamp was completed. A piece of charred paper cut into horse-shoe shape, so delicate that it looked like a fine wire, firmly

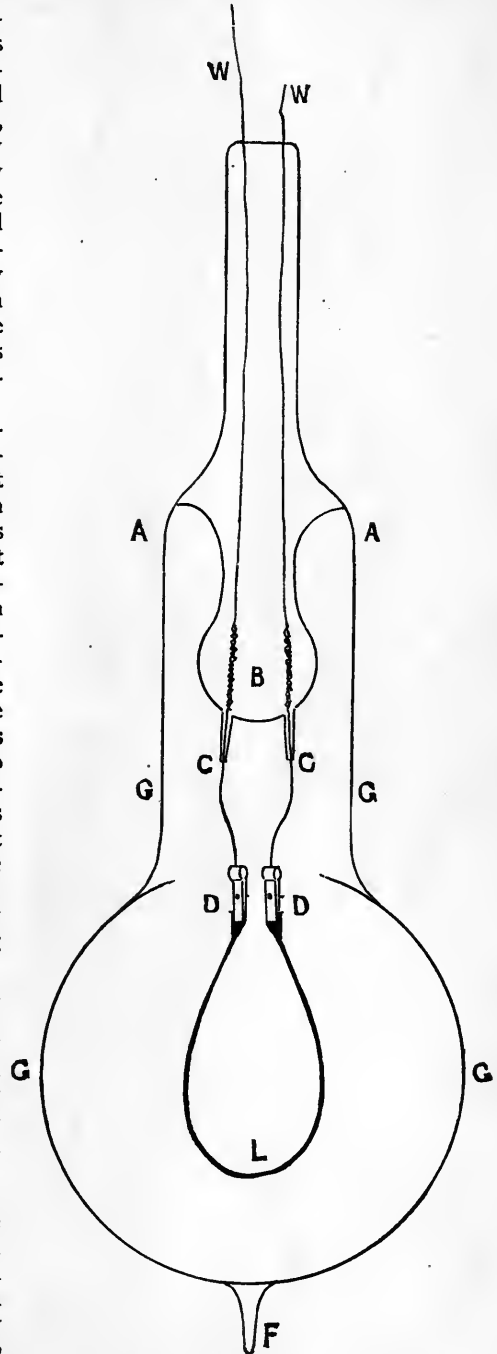

FIG. 8. EDISON'S ELECTRIC LAMP. EXACT SIZE.

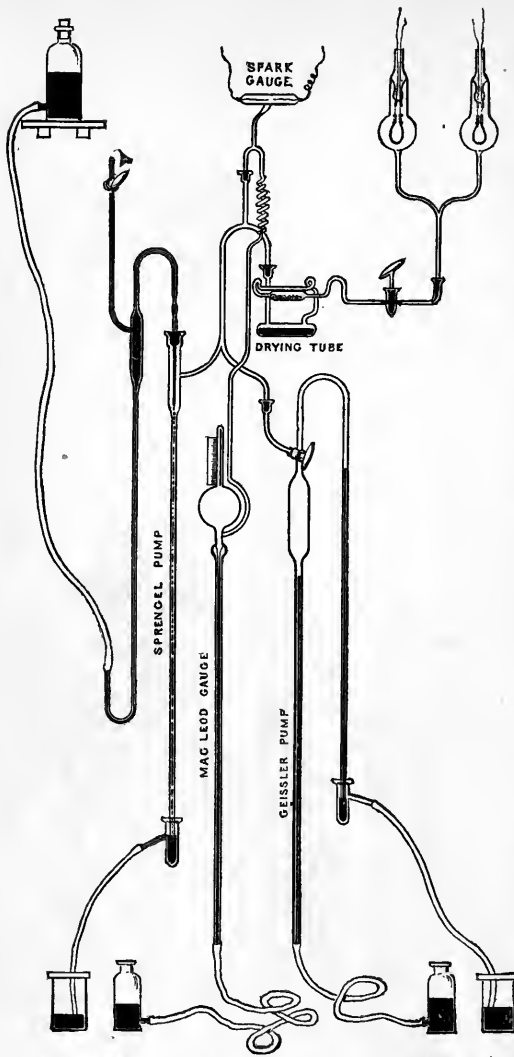

FIG. 9. MERCURY PUMPS FOR PRODUCING VACUUMS.

clamped to the two ends of the conducting and discharging wires so as to form part of the electric circuit, proved to be the long-sought combination. From this a light, equal in power to twelve gas-jets, may be obtained. Fig. 8.

The process by which the paper is rendered serviceable is also extremely simple and inexpensive. The horse-shoe loops are cut from card-board and placed in layers, within an iron box, with tissue-paper between; the box is hermetically sealed, and then raised to a red heat. Nothing remains but the carbon loops and the carbonized tissue-paper. All other forms of carbon previously used had presented the difficulty of containing air or gas. The car-

bonized paper, however, is found to be perfectly homogeneous in structure, elastic, tough, and of an almost vitreous cleavage. It is strong enough to stand far more strain than will be put upon it in any ordinary use. If this paper were burned in air, or in a vacuum prepared by a common air-pump, it would of course be almost instantly destroyed. In a high vacuum it burns, but is never consumed. The small glass globe which holds the simple apparatus is exhausted of air by means of nearly the same combination of the Sprengel and Geissler mercury pumps used by Crookes in making his radiometer, or "light mill," and in his wonderful discovery of the phenomena of radiant matter in high vacuums, recently brought before the Royal Society of England. Much attention has been bestowed of late on the question of securing good vacuums. An absolutely perfect one is unattainable. It is, however, found that, by the use of the mercury pumps and chemical appliances, where a nearly perfect vacuum is formed, the minute portion of air remaining shows some remarkable properties. When electricity under strong pressure passes through an Edison lamp, the whole bulb shines with a delicate blue light. So remarkable is the behavior of various substances in a vacuum prepared by means of mercury pumps, that physicists consider that a gas thus rarefied constitutes another state of matter, differing as much from that of an ordinary gas (either under atmospheric pressure or with the pressure removed by means of a common air pump) as a gas differs from a liquid, or a liquid from a solid. Mr. Edison's use of carbon in such a vacuum is entirely new.

The pumps are shown in Fig. 9; the Geissler pump is to the right and below. By raising a bottle which is connected with it, the air is forced out of a large glass bulb, and allowed to escape through the tube A. On lowering the bottle, the mercury flows back into it, leaving a vacuum in the bulb. The opening of a stop-cock allows some of the air which is left in the pump to flow into this bulb, when the air is again forced out as described; this is continued until the air is exhausted. The working principle of the Sprengel pump is the continuous dropping of mercury through a tube, each drop acting as a piston, carrying before it a small quantity of air. As there is no return stroke, even by the aid of a small tube, the work of exhaustion goes on

quite rapidly. The MacLeod gauge in the center is so constructed that it will measure with exactness when less than one-millionth of the original air is left in the pump.

Another purpose besides that of preventing the destruction of the carbon is served by burning it in a vacuum. Almost all the electricity is converted into light, very little being dissipated by convection or conduction as heat. The little glass globe only an inch from this brilliant light remains cool enough to be handled, and does not scorch tissue-paper wrapped closely around it.

Fig. 8 shows the lamp of its actual size. The current enters it by one of the wires, W. At B this copper wire is twisted and soldered to a platinum wire, which passes through the glass at C, and by means of a small platinum clamp into the horse-shoe, L, from which, by as simple a route as it entered, it returns. L, the source of light, was made in the form of a horse-shoe, in order to approximate to the shape of a gas-jet, and is large enough to cause the edges of the shadows to be softened down, and so obviates the common objection to familiar forms of electric lighting. The carbon is sealed in a glass bulb, G G G G, the knob of glass, F, is the melted extremity of the tube by means of which the bulb was connected with the pumps. At the points, C, C, where the platinum wires are sealed into the bulb, some trouble was occasioned by the cracking of the glass, which allowed air to leak into the bulb. It will be noticed that the glass is now drawn up around the wire in a thin tube. This is found to heat and cool so rapidly that it is practically homogeneous with the wire, and even if the wire be heated red-hot it will not break. Mr. Edison has tried putting a lamp alternately on and off the circuit for several hours by means of a telegraph key, without loosening the wire. This experiment was equivalent to using the lamp several thousand times.

Mr. Edison has thus succeeded in making a lamp of the simplest imaginable construc-

tion, and of materials whose expense is extremely small. The paper costs next to nothing, the glass globes very little, and the platinum tips of the wires are so small that, though the metal used is expensive, their cost is trifling. The test of the value of every invention is its simplicity, and this is the crowning characteristic of Mr. Edison's lamp, for it is really nothing more than a piece of wire looped into a glass globe.

The lamp being complete, let us consider the generator [Fig. 10], for which Mr. Edison has proposed the name Faradic, in honor of the great physicist.

The cylinder which is placed below, between the blocks of iron, F, on which the

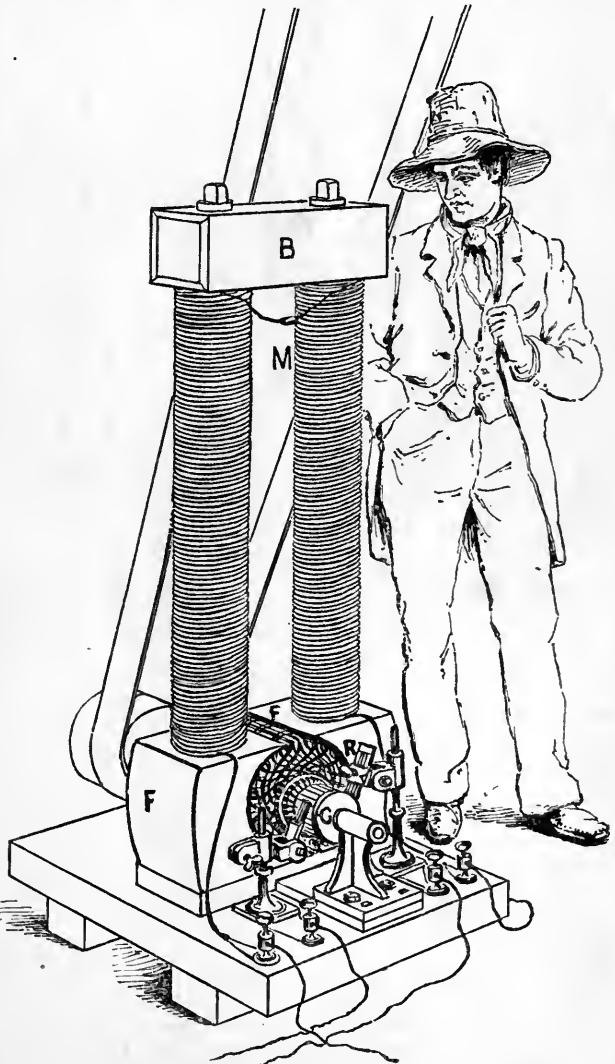

FIG. 10. FARADIC GENERATOR.

magnets, M, rest, is called the armature, and is so arranged that it can be made to revolve rapidly by means of a belt. This armature consists of a small cylinder of wood, which is wound around with iron wire as thread is wound on a spool, the ends being made as in a spool, to hold the wire in place. Around the whole spool are a number of loops of copper wire, covered with cotton thread, running lengthwise of the armature. The ends of these loops may be seen as they are taken from the armature to the cylinder, C, which is an extension of the armature, by which the currents generated in the copper wire may

which is pumped through the machine, may meet with as little friction as possible in passing through the wire of the armature, since by means of the great strength of the magnets, very little wire can be made extremely powerful in forcing the electricity to a higher level or in putting it under pressure. It is exactly as in pumping water, if we have a poor pump (analogous to a machine with a poor magnet) the water may meet with an enormous friction in the pump itself, or require two or more, perhaps, to give it the required pressure, while in a good pump all the parts are so made that while great pressure is

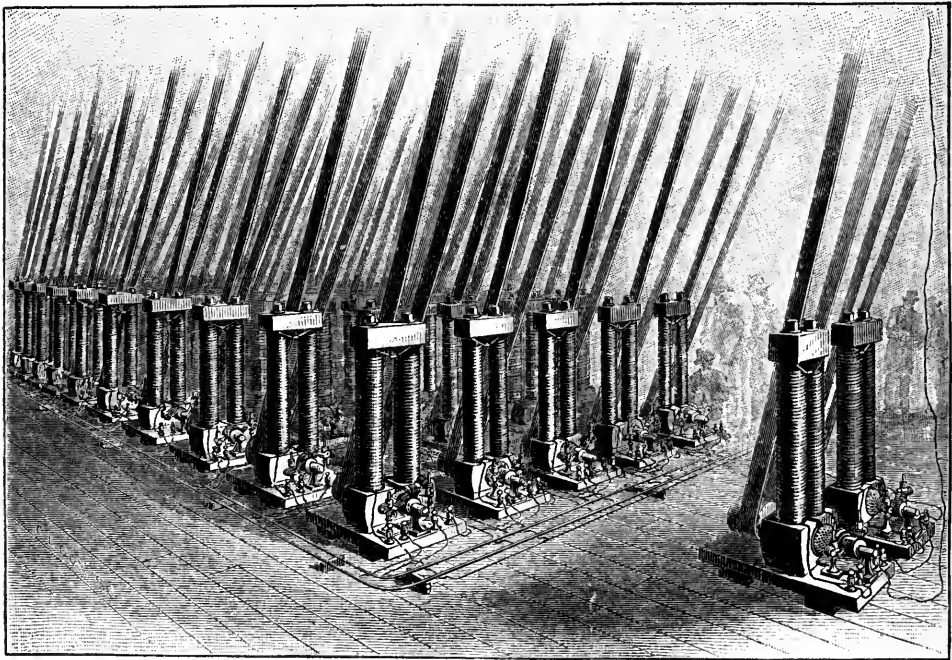

FIG. 11. PROPOSED CENTRAL STATION.

be taken away from the machine. This cylinder, called the commutator, consists of blocks of copper that really represent the ends of the wire, which are placed side by side around the axis of the cylinder in such a manner that no current can pass from one to the other. Touching these as they revolve are brushes, R, made of copper wire, by means of which the electricity flows from the machine.

That the wire about the armature may be able to pump electricity into the line, it is needful that it be revolved immediately in front of magnets. The magnets are made of such large dimensions that the electricity,

given to the water, it passes through it with the utmost freedom. The machine has such strength that it is intended to use only a small fraction of the power, which it could convert into electricity, and deliver outside.

It is proposed to mass a large number of such machines, as in Fig. 11, and have them all pump electricity up from one wire into a second. The two large wires, held on supports above the floor, are intended, the one to carry the electricity away, and the other to bring it back after it has been used. Two machines are placed at one side; these are for the purpose of rendering active the magnets of all the others.

It is proposed to establish such stations in the course of a few months in the heart of several of our large cities. These will supply houses for quite a distance around them. 1,000 horse-power is thought to be a sufficient amount for a unit, and the stations

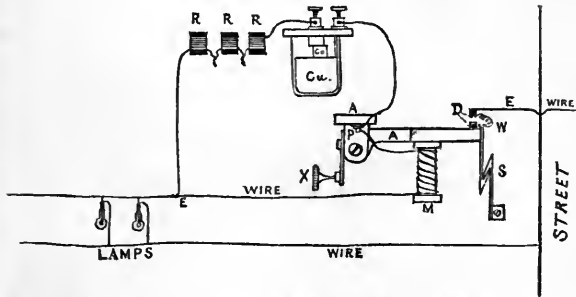

FIG. 12. DIAGRAM OF METER AND SYSTEM.

will be at such distances from one another that each district will require about this amount. The engines will be divided into four groups of 250 horse-power each, with a spare one in each station of the same power.

The wires will be laid in fascines or bundles under the edge of the sidewalk in a tight box. The object of this is to make them easy of access and easy to place in position. Nor is there need of putting them out of the reach of the frost, for they are continuous and not liable to leak from change in position. Even more important is the fact that the colder the wires are the less is the waste of electricity, thus giving a decided advantage over gas in winter, when most light is needed.

The main wires may be either of iron or copper according to the market price of these metals; as quotations are to-day the preference is slightly in favor of copper wire. These lines of wire will start from the central station and send out branches in the same manner that gas or water pipes diverge, growing smaller the farther they are removed from the central station. Fig. 12 also shows the branch wires as they enter the house. It is proposed to color the distributing wires red and the waste wires green. These two distinct wires will be carried all through the house, and every lamp will be so placed that the electricity will flow through it from one wire to the other.

Before passing into the house, the electricity is carried through a sort of meter containing a safety-valve, by means of which it can be measured. The contrivances for doing this are shown in diagram, in Fig. 12, and in perspective in Fig. 13. The lettering is the same in both for identical parts. The current enters at E, passes through the two platinum points, D, then through the armature, A, to the dividing points, P P. The larger portion of the current then flows around the magnet, M. The armature above the magnet is held from it by means of the spring, X. The object of the device is to furnish a means of cutting out a house if too large a flow of electricity by any accident should occur. The magnet would

then be capable of drawing down the armature which would separate the platinum points, D, and break the circuit.

The small wire, W, serves a double purpose and is a remarkably clever solution of a double problem. First: If the circuit were partly opened it would weaken the magnet, and the armature would recede, closing the circuit. It would thus form a vibrator

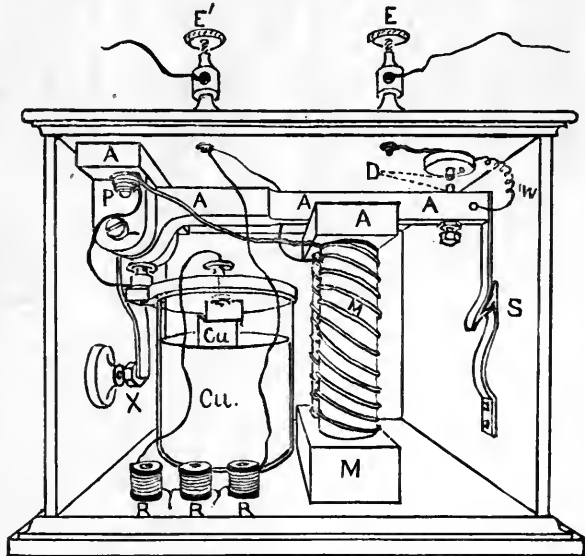

FIG. 13. EDISON'S ELECTRIC LIGHT METER.

resembling Fig. 6. The wire, W, allows enough electricity to pass to close the snap, S, so that the armature is firmly held in place, after which the wire, W, will melt off and completely break the flow of electricity. Secondly, the wire serves another purpose:

if the points were drawn apart an arc would spring between them. The wire, W, conducts the electricity by a shorter route than that offered by an arc and so keeps the space between the two points free from the intensely heated vapors of the metal.

A small fraction of the current passes by another route to the lamps, from the point P. It first traverses a length of wire wound on small spools marked R. The amount placed here will regulate the flow through this line. The current next passes through from one copper plate marked Cu to another, through a solution of copper salt. In thus flowing, for every unit of current a certain amount of copper is deposited on a thin sheet, the amount for a lamp being once determined by burning one for a number of hours. It must be remembered that only a small amount passes through the meter, but that which passes is proportionate to the whole. It is proposed to make a standard lamp, which shall give a light equal to that from a gas flame consuming five cubic feet each hour. From this it will be calculated how much copper will be deposited, and the amount will be said to represent five cubic feet. The bills for electricity will be made out in 1,000 feet, as in the case of gas. The inspector will take the strip on which the copper is deposited to the central station, in order to determine the amount of electricity used.

Besides giving light, the electricity supplies a convenient form of motor for domestic purposes. A small electrical engine placed beside a sewing-machine, for exam-

power, by this same means. Fig. 14 shows the form adopted by Mr. Edison. It is substantially a small model of the large Faradic machine, the only change being in the fact that the armature, C, is placed lengthwise of the magnets, MM, instead of across them. At S is a switch by means of which the motor can be started or stopped. It is expected that the amount of power used in the day time will largely pay for the expenses of generating—an additional advantage over gas.

In order to use the lamp, it is brought into the circuit by turning a handle in a certain direction, or thrown out by reversing the motion, or by means of plugs, which are inserted in a socket. This may be done either in the chandelier or in any other convenient place in the house. Very simple arrangements may be made so that by touching a knob by the bedside the whole house may be brilliantly lighted for the reception or discovery of a suspected burglar. Of course, no matches have to be used; the light kindles itself by the turning of a handle, and so one fruitful source of destructive fires is avoided.

In order that the philosophical relations of the processes may be understood it is needful to trace the history of the energy as it is taken from the coal and conveyed over the wire to the lamp. A large portion of the heat produced by the combustion of the coal under the boiler is found in the steam as it flows to the engine. By means of the latter a small fraction, about ten per cent.

of the original energy, is transformed into the motion of the wheels attached to the engine. It may be traced as it flows through the belt to the shaft, and again as it is carried from the shaft to any machine which it may drive. A belt exactly resembles, in carrying power, a man pulling a shaft around by means

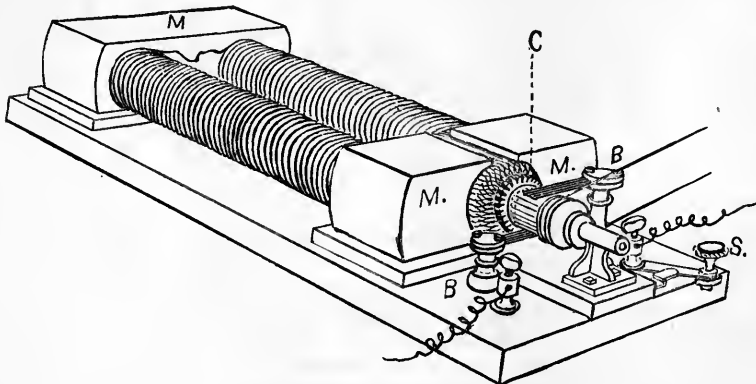

FIG. 14. EDISON'S ELECTRIC MOTOR.

ple, and connected with the distributing wire, may save all the fatigue of treading the machine, at an expense exactly equal to that of one jet burning for the same time. Elevators may be lifted, lathes turned, and instruments operated up to several horse-

power. The amount he is pulling can be measured by the strain on the belt, and the work he is doing by determining the speed with which he carries the end of the rope. Mr. Edison has made a device, represented by Fig. 15, to measure this strain.

drag put upon the copper. This phenomenon Tyndall calls the apparent viscosity of the magnetic field. Faraday, a few years after this discovery, clearly explained the reason for seeming friction between the plate of copper and the invisible lines of magnetic force which he imagined to reach out from every magnet. He used wires and passed them in front of the magnet, and found that whenever they were made to cut these lines electricity was thrown into the wire. This grand discovery is at the basis of all that is now done in making strong currents, for it furnishes the method by which motion of mass may be transformed into the molecular motion called electricity.

As the energy appears in the wire, it is measured again by an electrical dynamometer, the main idea of which was that of Professor Trowbridge, of Harvard University.

By means of the two instruments, one is enabled to trace out the amount of energy absorbed and given back by the machine, and in many cases ninety per cent. of the original power applied is found converted into electricity. A system of electric lighting is nothing more than a gas system, where energy takes the place of vapors.

It is one of the laws of progress, that no sooner is a method for producing a certain result perfected than a practical use of it follows. This is attested by the history of many great inventions. Following out the laws of discovery, it has been for some time

a speculation of the writer that the wonderful perfection to which vacuums had been brought, pointed historically toward some direct connection between them and the electric lamp. For the past few years no more striking result of scientific work has been effected than the startling phenomena shown in high vacuums; parallel with this, a growing want has been felt for a cheaper and more efficient mode of illuminating. Is this a mere coincidence? or may we believe that the demand and means of supply have been developing independently, but side by side; and that now in the electric light we find a practical application of what had been reached by purely theoretical research?

Besides the enormous practical value of the electric light, as domestic illuminant and motor, it furnishes a most striking and beautiful illustration of the convertibility of force. Mr. Edison's system of lighting gives a completed cycle of change. The sunlight poured upon the rank vegetation of the carboniferous forests, was gathered and stored up, and has been waiting through the ages to be converted again into light. The latent force accumulated during the primeval days, and garnered up in the coal beds, is converted, after passing in the steam-engine through the phases of chemical, molecular and mechanical force, into electricity, which only waits the touch of the inventor's genius to flash out into a million domestic suns to illuminate a myriad homes.

"THAT LASS O' LOWRIE'S."

LIKE those grand heights of far-off northern lands
 (With desolation at their skirts), which bare
 Their brows to radiance of transcendent air,
 Majestic in her loneliness she stands—
 Yet tender to a touch: with craving hands
 That draw a slighted baby's mouth to share
 The sweetness of her lips, in kisses rare
 Of love her own defrauded life demands.
 What matchless courage sets her steadfast feet
 Along their path of thorns! She, hopeless, takes
 Her pain, her love, all hopes most sweet and near,
 And goes—unwittingly—crowning joy to meet!
 The Joan of our love! whose story makes
 Our true and tender womanhood more dear.

PETER THE GREAT.*

BY EUGENE SCHUYLER.



TSAR ALEXIS, FATHER OF PETER THE GREAT.

PREFATORY NOTE.

WHAT I shall say in these papers is founded on the diligent—and I hope the impartial—study of original documents in the archives of various countries, of the Russian collections of laws and state papers, of the memoirs and accounts of Peter's contemporaries, of the works of Russian historians, and of most of the important books written on the subject by foreigners.

My views of portions of the history of the times under consideration differ in some respects from those commonly entertained. I have not thought it necessary to emphasize them by attempting to refute the views of others, or by disproving anecdotes and stories in such common circulation as to have be-

come almost legendary. I shall tell the story of Peter's life and reign as I understand it, and I hope that my readers will believe that I have good evidence for every statement that I make. In a publication of this kind it would be undesirable to encumber the pages with foot-notes giving my authorities; I reserve those for another time, but meanwhile hold myself ready to answer any questions addressed to me personally.

For the convenience of the reader, I have avoided as far as possible the use of purely Russian words and titles, and where I have not used the English forms of proper names I have placed an accentual mark to facilitate pronunciation.

EUGENE SCHUYLER.

ROME, October, 1879.

CHAPTER I.

SECOND MARRIAGE OF THE TSAR ALEXIS.—
BIRTH OF PETER.—HIS INFANCY.

WHEN the Tsar Alexis was still in the bloom of manhood—and it should be remembered that he was just two months older than Charles the Second of England—



TSARITSA NATALIA, MOTHER OF PETER THE GREAT.

he lost his wife, the Princess Marie Ilínitchna Miloslávsky, who, during a married life of barely twenty-one years, had given birth to thirteen children. Several of these had died in their infancy; and the Tsaritsa herself expired in giving birth to her last child on the 12th of March, 1669. Three months later Simeon, the fourth son, died; and half a year afterward Alexis, the eldest son and heir to the throne, expired—at the age of sixteen. Of the two sons still living, Theodore was very infirm and sickly; and Joánn, or Iván, was almost blind, had a defect of speech, and lacked little of being an idiot. Under the circumstances it became evident to every one that the Tsar would, in all probability, marry again, and the parents of all marriageable girls were busy preparing them for the customary and traditional inspection of candidates for the hand of the Tsar. All, however, were doomed to disappointment.

Alexis frequently visited his chief minister and tried friend, Artémon Serghéievitch Matvéief. This minister, from his leaning toward all that came from Western Europe, although he kept the same open house, had adopted different manners from most of the Muscovite aristocracy and officials. The females of the family, dressed in what were called German clothes, did not scruple to appear at table or in the presence of visitors. To please the Tsar, Matvéief frequently

had concerts and other amusements, and tragedies, histories, and even comedies, were performed in his private theater. Matvéief had no daughters, but he had living with him a ward, the daughter of an old comrade, Cyril Narýshkin, a chamberlain and a landed proprietor of the remote district of Tarus, one of a noble but little known family, several members of which had died in arms for their country. Under the charge of Matvéief's wife, Natalia Narýshkin was receiving her education at Moscow—a tall, shapely, black-eyed, black-haired girl. One evening, when the Tsar was at Matvéief's house, the wife and the pretty ward of the Prime Minister came into the room, bringing, as usual, the cups of *vodka*, the caviare, the smoked fish, and the other whets to the appetite which are taken before the Russian dinner or supper. The widowed Tsar, in the depth of his grief and gloom, was struck by the pretty face, and still more by the modest smile—neither forward nor too much abashed—and by the sensible answers he received to his questions. He ate with more than usual heartiness, and seemed to enjoy the evening, and on going away said to Matvéief that he would find a bridegroom for his pretty ward. Notice had already been served for the inspection and review, on the 11th of February, of the young girls, either in Moscow or the distant provinces, whose position and beauty rendered them suitable to be the Tsar's bride, and word was now sent to Natalia Narýshkin to appear among the others. According to custom, all the maidens then present assembled again for inspection on the 28th of April. Report soon bruited it about that Natalia Narýshkin was the chosen one. This caused an unpleasant sensation in the Krémelin. The daughters of the Tsar—several of them older than Natalia Narýshkin—objected to so young a stepmother. They objected, too, for a more serious reason, as her relations, according to accepted usage, would immediately come into court favor, while their own relatives, the Miloslávskys, would lose their positions, and would perhaps be sent into exile. There was jealousy on the part of many families of much higher position in the social and political world than the Narýshkins, each one desiring to obtain for his own friends and adherents the places which would evidently be vacated by the Miloslávskys. The Miloslávskys themselves would have preferred a bride belonging to some family which they could easily influ-

ence, and thus, perhaps, keep themselves in power. The opposition to the choice of the Tsar was carried to such a length that there were fears of a repetition of the scenes which caused the ruin of the first bride of the Tsar Michael, and of the one first chosen for Alexis himself. In 1616, the Sáltykofs, at that time the ruling family at court, had so much disliked Marie Khlópof, whom the young Tsar Michael

Michael, had been suddenly taken ill and had died on the day appointed for the marriage. In 1647, two years after he had ascended the throne, Alexis had resolved to marry, and out of two hundred young girls chose Euphemia Vsévolozhsky. When she was attired for the first time in the royal robes, the ladies-in-waiting twisted her hair so tightly that she swooned in the Tsar's presence. The court physicians were induced



RUSSIAN HOSPITALITY DURING THE TIME OF IVAN THE TERRIBLE. (FROM A PAINTING BY SCHWARTZ.)

was about to marry, that they had drugged her till she was ill, represented her as incurably diseased, and caused her to be exiled with all her family to Siberia, where she remained for seven years, till the fall of the Sáltykofs, when she was allowed to reside at Nízхни-Nóvgorod. The Princess Marie Dolgorúky, the second bride of

to declare that she was afflicted with epilepsy, and Euphemia and all her relatives were exiled to Tiumén in Siberia.

So there was evidently danger for Natalia Narýshkin.

Only four days after the second inspection two anonymous letters were found on the porches of the palace, in which accusa-

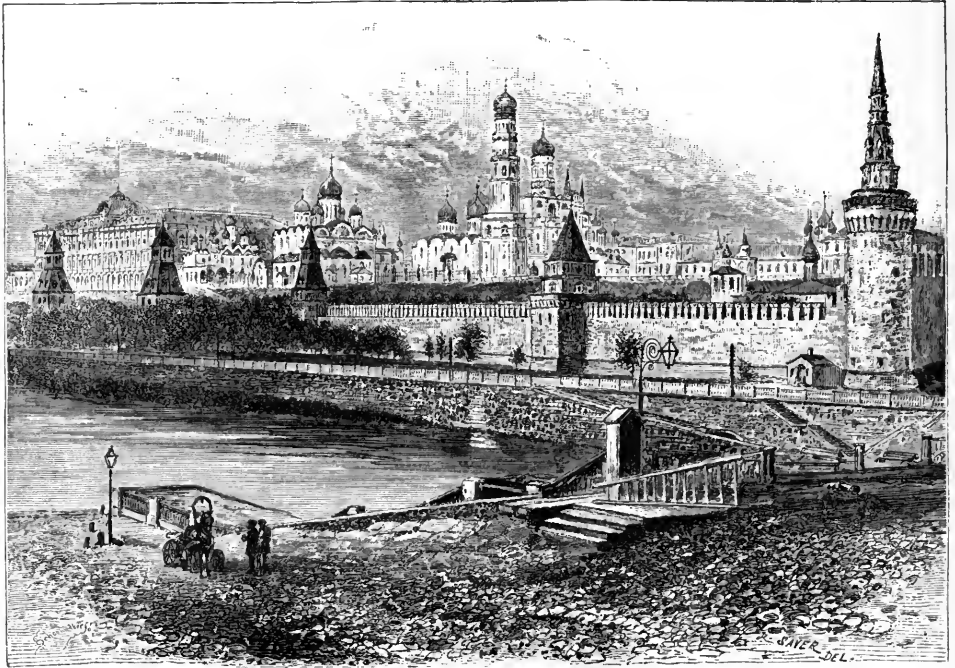

THE KREMLIN, MOSCOW.

tions were made against Matvéief of sorcery and witchcraft, and of using magic herbs to attract the mind of the Tsar toward his ward. There was a strict investigation, accompanied, as was then customary, with torture, and the contemplated marriage was put off for nine months; but it was finally celebrated on the 1st of February, 1671, with all the customary pomp, dinners, feasts, and public rejoicing, of which the Tsar Alexis was so fond.

In spite of the intrigues and dissatisfaction of the elder daughters of the Tsar and of their relatives, the Miloslávskys, everything was pleasant on the surface; and all the young people of the court amused themselves as usual during the summer in the villas and palaces in the neighborhood of Moscow. The Tsar was devoted to his wife, was never for a moment without her, and even took her to his park of Sokólniki, where he often indulged in his favorite pastime of hawking. To the delight of the people, and of all who feared what might happen from the feeble health of the two remaining sons of the Tsar, a report was spread, during the winter, that the Tsaritsa was in a delicate state of health—a report which was shortly after officially confirmed; and at about one o'clock on the morning

of Thursday, the 9th of June, 1672*—the festival of St. Isaac of Dalmatia—a son was born, who was later christened Peter, and who subsequently became known as Peter the Great.

Messengers were immediately sent to the Metropolitan—for the patriarch was dead, and his successor had not yet been elected—to the other clergy, and to the chief monasteries, both at Moscow and Sérghia-Tróitsa, to all the officials, and to all the higher nobility in Moscow. At five o'clock in the morning the great bell of the Tower of Iván Velíki announced the birth of a prince and gave the summons to prayer. The Tsar Alexis was exceedingly fond of ceremonial display and spent much of his time in arranging the details of the great court ceremonies, the receptions of ambassadors, and the solemn religious state processions. In consequence of the great delight the Tsar felt at the birth of his son, additions were made to the customary ceremonial. A procession headed by the Metropolitan and clergy in robes of cloth-of-gold, with banners and crosses and swinging censers, left the palace of the Krémelin and went

* The 30th of May, according to the Russian calendar.

slowly round the great square to the cathedral of the Assumption. After the clergy marched in due order the higher officials of the government, the nobility according to their several ranks, and the colonels of the army; then all the members of the royal family—the princesses, beneath their closed canopies, being accompanied by the wives and the daughters of the great nobles; and then citizens of Moscow acting as deputations from the merchants and from the various classes and guilds. After prayers and a solemn thanksgiving service the Metropolitan and clergy felicitated the Tsar upon the birth of his son; and then Prince Nicholas, of Georgia, advancing with the Princes of Siberia and Kasimof, who were living at Moscow under the protection of the Tsar, presented the congratulations of the nobles and the citizens, and pronounced an address prepared for the occasion. From the cathedral of the Assumption the procession passed to the cathedral of St. Michael the Archangel, then to the Miracle monastery

and to the monastery of the Ascension, and finally to the cathedral of the Annunciation, the nearest to the palace, where mass was celebrated. On returning to the palace the Tsar held a reception in the banqueting hall, and raised the father of the Tsaritsa, Cyril Naryshkin, and the prime minister, Matvéief, from privy-councillors to the dignity of *okólnitchi*, the highest official rank but one, and only inferior to that of a *boyár*.* An uncle of the Tsaritsa, Theodore Naryshkin, was promoted, with others.

* The title of *Boyárin* and *Okólnitchi* given to the two highest classes of the old Muscovite officials are even more untranslatable than Pasha and Bey. They were purely personal and not hereditary titles; they conferred a rank in the state but brought no special duties with them. They were abolished by Peter the Great. Other official titles, such as *Díimnoi Diak*, *Spální*, etc., which have likewise been abrogated, I have made a shift to translate so as to give an idea of their functions. Just as lately in Roumania, so in olden Russia, the word *boyárs* was used by the common people as comprehending all the nobility and officials.



A GROUP OF BOYARS. KREMLIN IN BACKGROUND.

to the rank of privy-councillor. Then, in the ante-room, the usual refreshments on the birth of the child were given to the guests, the Tsar with his own hands passing about *vodka* and foreign wines to the nobles and officials, while boyárs, specially assigned to this duty, distributed fruit and wines to the army officers who stood without the palace. The only deviation from the customary feast was that the distribution of confectionery, usual on these occasions, was postponed to another time.

It was customary to give a large state banquet soon after the birth of a prince, but the fast of St. Peter beginning on Monday, and Saturday night being also the fast before the festival of All Saints, which the Russians celebrate on the day we call Trinity Sunday, it was not only impossible to prepare a banquet of the usual kind in two days, but it was also difficult for the guests to come provided with the customary birth presents. A small private supper was nevertheless given in the Golden Hall on the Sunday to the boyárs alone, it being understood that there were to be no personal invitations and no precedence at table.

The Tsar having decided to give the name of Peter to the new-born child, the christening was fixed, after the fasting period was over, for the Feast of SS. Peter and Paul, the 20th of June (old style), that is, according to our calendar, the 9th of July. The christening took place before mass, in the Miracle monastery, in the refectory of St. Alexis, the miracle-worker. The ceremony was performed by the Tsar's confessor, Andréi Savínovitch, priest of the cathedral of the Annunciation, and the child was held at the font by Theodore Narýshkin, the elder brother of the Tsaritsa, who handed it to the Princess Irene, one of the daughters of the Tsar Michael and the sister of Alexis. The child was borne to the church in a cradle placed on wheels, while the priest most venerated for his sanctity—Nikita—sprinkled the path with holy water. On the next day, the 10th of July, which was Sunday, the clergy, with their holy pictures, their crosses, and their gifts, the boyárs and nobles, the delegates from the merchants, and other citizens, both from Moscow and from the neighboring towns and villages, all with the customary birth gifts, met in the palace for morning service, after which the table was spread in the banqueting-hall. Banquets on occasions of birth differed from those given on other great occasions in the pal-



ST. PETER (AFTER A MODERN PAINTING IN A MOSCOW CHURCH).

ace, especially in the variety of the confectionery and wines. The expense and account-books which have come down to us show that on this occasion the tables fairly groaned under the weight of large pieces of sugar-work, which included immense

representations of the Muscovite arms; eagles, swans, and other birds, even larger than life; a model of the Krémlin, with people going in and out, and also a large fortress, with cannon. At the same time the Tsaritsa gave a banquet to the wives and daughters of the boyárs in her private apartments. Each of the guests at these two banquets, on departing, received to take home a large plate filled with sweets of various kinds, the quantity, however, proportioned accurately to the rank of the guest. Smaller plates of sweets were sent to those notable persons who were not able to be present at the christening feast. Other banquets followed for four days.

One of the first ceremonies after the birth of a Russian prince was what was called "taking his measure,"—that is, painting the image of his patron saint on a board of either cypress or linden wood, of the length and breadth of the child. The measure of Peter was taken on the third day after his birth, and the most skillful artist of the time—Simeon Ushakóf—was ordered to paint a picture representing the Holy Trinity, together with the Apostle Peter, on a board of cypress wood nineteen and a quarter inches long and five and a quarter inches broad. This artist, however, was taken ill and died before he had finished the picture, which was completed by another, Theodore Kozlóf. This "birth-measure" of Peter, as it is called, was carefully preserved, and now hangs over his tomb in the cathedral of SS. Peter and Paul, in the Fortress at St. Petersburg.

A governess was found for Peter, first in the person of the Princess Juliana Galítsyn, and subsequently in the boyár's wife, Matréná Leóntief; and a nurse, who was obliged to be "a good and clean woman, with sweet and healthy milk," in Neoníla Lvof.

Besides the nurse and his governess, a prince in those days had a special staff of dwarfs, to be companions and at the same time servants. He had also his own apartments. Peter and his nurse were at first placed in some small rooms in the upper and wooden part of the palace, the walls of which were hung with common cloth. But only a year from his birth—in August, 1673—we find orders for one of the rooms to be hung with leather stamped with silver, and a year later new apartments were prepared, the walls of which were hung with fine red cloth, and the furniture covered with red and crimson, embroidered with yellow and blue. In 1676 the walls and part of the ceiling were dec-

orated with paintings. In his earliest years Peter enjoyed all the luxury which at that time surrounded a prince, and from which, later on, he so readily broke away. The curious books of accounts mention numerous articles ordered for him in the first four or five years of his life: cradles, covered with gold-embroidered Turkish velvet, sheets and pillows of white silk, coverlets of gold and silver stuffs; caftans, coats, caps, stockings and shoes of velvet, silk and satin, embroidered with gold and pearls; buttons and tassels of pearls and emeralds; a chest for his clothes, covered with dark-blue velvet and ornamented with mother-of-pearl, and a miniature carriage, drawn by ponies, in which he was taken out to drive. Nor were playthings of all kinds wanting: toy-horses, miniature clavichords, and musical instruments of various kinds, dolls, wooden figures, hobby-horses, toy carriages and carts, and a swing. The most common toys, however, were miniature bows and arrows, pikes, spears, wooden guns, banners, and all sorts of military equipments. But as military things were destined to play such an important part in Peter's early education, I shall leave this subject for a moment.

Physically, Peter developed rapidly. He was able to walk when six months old, and being active, bright and intelligent, he took an interest in all that was going on around him. Being the pet of his parents, he constantly accompanied them in their excursions and visits in the neighborhood of Moscow. In May, 1675, Matvéief presented him with a small carriage of foreign workmanship, drawn by four small ponies, in which he was driven and guided by the court dwarfs, and began to take a part in the court and public processions. An eye-witness, Adolph Lyseck, an Austrian Secretary of Embassy, in describing the court procession to the Trinity monastery in September, 1675, says:

"Immediately after the carriage of the Tsar there appeared from another gate of the palace the carriage of the Tsaritsa. In front went the chamberlains with two hundred runners, after which twelve large, snow-white horses, covered with silk housings, drew the carriage of the Tsaritsa. Then followed the small carriage of the youngest prince, all glittering with gold, drawn by four dwarf ponies. At the side of it rode four dwarfs on ponies, and another one behind."

Lyseck in another place speaks of his official presentation to the Tsar Alexis at the palace of Kolómensky:

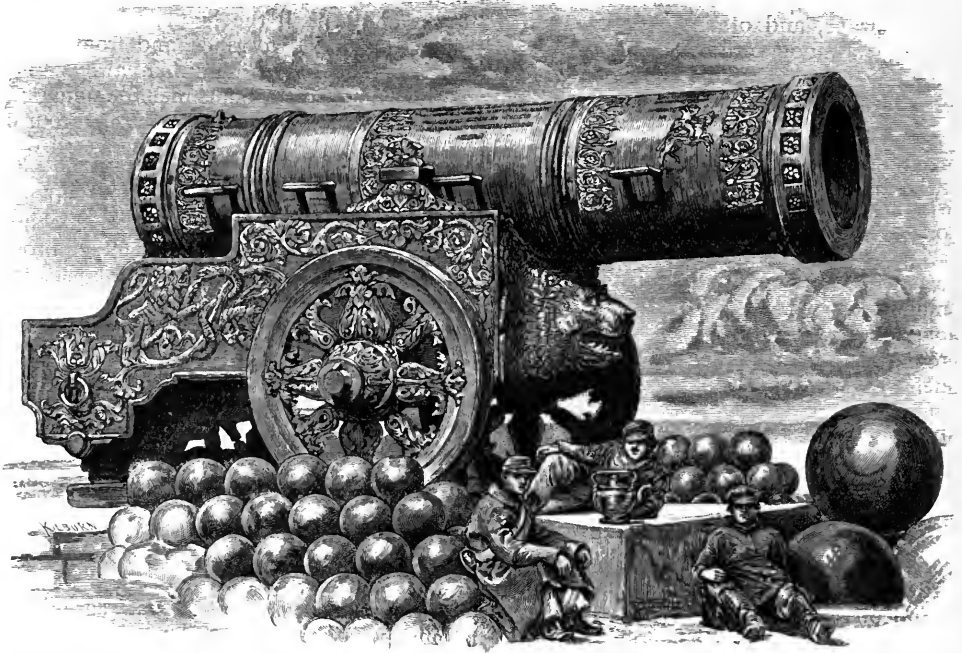

THE TSAR PUSHKA, OR EMPEROR CANNON. (DRAWN BY FRANCIS LATHROP FROM A PHOTOGRAPH.)

“The door on one side suddenly opened, and Peter, three years old, a curly-headed boy, was seen for a moment holding his mother’s hand and looking at the reception. This was to the great astonishment of the court.”

The favorite resort of the court at that time was the palace of Preobrazhensky. Here Matvéief had caused a small theater to be built in one of the large halls, and a company of German actors gave comedies, assisted by various boys and young people from the court and the children from the Mestchansky—a quarter of Moscow inhabited principally by Poles from the western provinces. The first play performed was “Judith”; another time the story of Esther was represented, in which the spectators thought they saw references to contemporary events: Ahasuerus and Esther portraying the Tsar and the Tsaritsa, Mordecai being Matvéief, and the wicked Haman one of the Miloslávskys. I find mention also of the histories of “Joseph,” and “Tobit,” and finally even plays on historical subjects not Scriptural, such as the invasion of Tamérlane. Usually, after the comedy, German musicians gave a concert, or jugglers performed feats of legerdemain. The comedies sometimes lasted five or six hours consecutively, and the feasting went on until morning.

CHAPTER II.

LIFE AT COURT.

WHEN the Tsar was in Moscow, life at court must have been very uniform and sometimes monotonous. Alexis usually rose at four o’clock, and after making his toilet with the assistance of his chamberlains and gentlemen of the bed-chamber, went immediately into his oratory, where the priest and the deacon of the palace chapel awaited him. Here he remained in prayer for fifteen or twenty minutes. After this the deacon read extracts from devotional books suited to the day, the lesson being most frequently a portion of the sermons of St. John Chrysostom. When the Tsar kissed the holy picture he was sprinkled by the priests with holy water which had been brought from some church or monastery and had been consecrated on the festival of the saint to which that church was dedicated. After these early devotions the Tsar sent one of his chamberlains to the Tsaritsa to wish her good-morning and inquire after her health, and soon after went in person to visit her. The Tsar and the Tsaritsa then went together to one of the palace chapels and heard matins and a short early mass.

Meanwhile the nobles and courtiers had been collecting in the palace since an

early hour, and were awaiting in an ante-room the entry of the Tsar from his private apartments. As soon as Alexis appeared they all bowed many times and presented petitions and reports. Some of the officials bowed to the ground as many as thirty times in gratitude for favors received. After some conversation about officers of state, the Tsar, accompanied by all the nobles, went at about nine o'clock to his chapel to hear mass, which at ordinary times lasted about two hours. At convenient intervals during the service the Tsar received reports from the various departments and officials, gave answers, and consulted the boyárs about public matters, very much as though he were in the council-chamber. On great festival days, instead of hearing mass in the palace chapel, the Tsar and his court went to one of the large cathedrals, or to some

of discussing state business during divine service, there was scarcely any one in the country so pious as he. Doctor Collins, an Englishman, who was the Tsar's physician for nine years, says, that during Lent he would stand in the church for five and six hours at a time and make as many as a thousand prostrations—on great holidays even fifteen hundred.

After mass the Tsar and his nobles returned to the reception-room, where he continued to receive reports which were read by one of the secretaries, who also made suggestions to him relating to the proper answers. During the time that business was being conducted none of the nobles in the reception-room dared sit down. Everyone, except the Tsar, remained standing, although the boyárs frequently went out into the halls, or even outside into the court-



THE GREAT BELL OF THE TOWER OF IVAN VELIKI, RUNG AT THE BIRTH OF PETER THE GREAT.

church or monastery in which the festival was particularly celebrated. In this case there was a solemn procession, in which Alexis displayed all his accustomed magnificence. Although the Tsar had the habit

yard, in order to sit down and rest themselves. At the regular official meetings of the council, however, the boyárs and all the officials sat down in their proper places, one after the other, according to their rank,

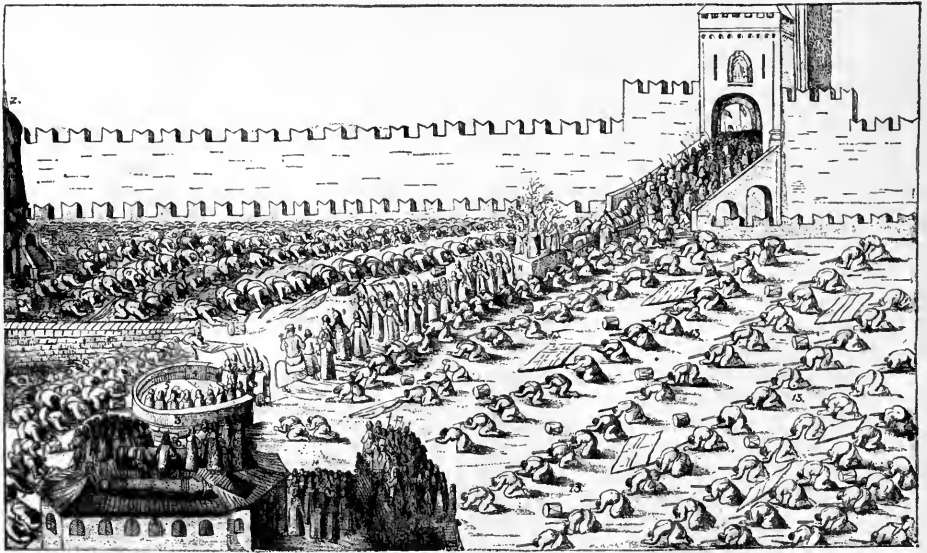

A RELIGIOUS CEREMONY IN MOSCOW IN THE 17TH CENTURY. (FROM A LITHOGRAPH FOR THE AUSTRIAN EMBASSY.)

those high in position being nearest the Tsar.

The business of state was usually finished by twelve o'clock, when the nobles retired, and the Tsar went to his dinner, to which he occasionally invited some of the more distinguished boyárs, though generally he ate alone. He was served by nobles of high position, who had the title of carvers, butlers, cup-bearers, and table companions. Every dish which was brought to him was carefully guarded by special officials from the time it left the cook's hands until it was placed on the table. In the same way, the wines and beer were tasted several times before they reached the Tsar; and the cup-bearer, who held the pitcher of wine constantly in his hands, tasted it afresh every time he poured out for the Tsar. The private table of Alexis was usually very plain. He ate the simplest dishes; the bread was the common Russian rice bread; he drank only a little wine or light beer, or sometimes a little cinnamon water, or had a few drops of oil of cinnamon in his beer, for cinnamon, Doctor Collins tells us, was the *aroma Impériale*. This, however, was nothing in comparison with his simplicity during the fasts. Doctor Collins says:

"In the great fasts he eats but three meals a week, viz., on Thursday, Saturday, Sunday; for the rest, he takes a piece of brown bread and salt, a pickled mushroom or cucumber, and drinks a cup of small beer. He eats fish but twice in the great Lent, and observes it seven weeks altogether, be-

sides Maslinets week, wherein they eat milk and eggs. Out of the fast he observes Mondays, Wednesdays, and Fridays, and will not then eat anything that comes of flesh. In fine, no monk is more observant of canonical hours than he is of fasts. We may reckon the fasts almost eight months in twelve, with the six weeks fast before Christmas, and two other small fasts."

On festivals, however, as many as seventy dishes were served at the Tsar's table, and nearly all these were given away, according to custom, as presents to the boyárs. Sometimes, as a mark of special honor, the Tsar would select his favorite dish for some particular friend.

After dinner the Tsar took a nap, which lasted about three hours, until vespers. The nobles again assembled in the palace for vespers, and during the intervals of the service the affairs of the state were again the subject of conversation and consultation, which sometimes continued, in the form of an irregular counsel, after service, although as a general rule the time until supper was spent by the Tsar with his family, or with those who were most intimate with him.

All the latter part of the day was given up to amusement. Much of the amusement of that time consisted in hearing books read aloud. Most of these books were of an ecclesiastical character, and related either to sacred or church history, to religious dogmas, or to the lives of the saints. The Tsars were frequently among the most learned men of their age in theology and

church history, and the most notable example in this respect was Iván the Terrible. Alexis was very fond, too, of having some one to read to him passages from the old chronicles of the Empire and extracts from the reports of his ambassadors abroad, and had translated for him the *courants*, or newspapers, then published in Western Europe. Besides these he loved stories of travel and of life in foreign parts and in remote regions of Russia, and kept in the palace, under the name of pilgrims and beadsmen, a number of old men who had

the funeral. Alexis was also fond of various games, draughts, backgammon, and especially chess,—and frequently had spectacles of various kinds, such as wrestling matches and other contests, in the hall specially devoted to that purpose. During the winter he occasionally visited a bear fight. He was fond, too, of inspecting the work of jewelers, armorers, and other handicraftsmen, which were brought to the palace. Of out-door sports he especially affected hawking, and when he went to Sokólniki, one of his favorite resorts for this kind of



RUSSIAN ARMS BEFORE THE TIME OF PETER.

wandered far and had seen much, and who had the gift of telling in lively style what they had seen and passed through. The dryness of official history was in this way relieved by anecdotes and sketches taken from life. The Tsar had great respect for these beadsmen, and when one of them died he was buried with a considerable amount of pomp and ceremony in the church of the Trinity hostelry, the Tsar himself attending

amusement, the whole order of things was changed. In general, during his visits to the country he paid less attention to the affairs of the state, was less strict in his religious exercises, and devoted far more of his time to amusement.

The Muscovite ideal of woman, founded on the teachings and traditions of Byzantine theology, was purely a monastic one. The virtues of the cloister, faith, prayer,

charity, obedience, and industry, were the highest virtues of a woman. The life of the cloister was best suited to preserve her purity. Socially, woman was not an independent being; she was an inferior creation, dependent on her husband, for except as a wife her existence was scarcely recognized. Of this theoretical position of woman, abundant proof is given in all the early didactic literature of Russia, and especially in the *Domostrói*, that curious manual of household economy written in the time of Iván the Terrible. The wife should be blindly obedient in all things, and for her faults should be severely whipped, though not in anger. Her duty is to keep the house, to look after the food and clothing, and to see to the comfort of her husband; to bear children, but not to educate them. Severity was inculcated, and to play with one's children was esteemed a sin,—a snare of the devil. The wife was bound to stay chiefly at home, and to be acquainted with nothing but her household work. To all questions on outside matters she was to answer that she did not know. It was believed that an element of evil lurked in the female sex, and even the most innocent sport between little boys and girls, or social intercourse between young men and women, was severely reprehended. The *Domostrói*, and even Pososhkóf, as late as the 18th century, recommended a father to take his cudgel and break the ribs of his son, whom he found jesting with a girl. Traces of this feeling with regard to women are still found in current proverbs. "A woman's hair is long, her understanding is short," runs one proverb; "The wits of woman are like the wildness of beasts," says another; while a third says: "As a horse by the bit, so must a woman be governed by threats." The collections of popular stories and anecdotes are full of instances of the innate wickedness and devilishness of the female sex, with references to all the weak or wicked women of sacred and profane history. In the "Great Mirror," compiled in the 17th century, we even find the obstinacy of women exemplified by the well-known anecdote of the drowning woman, still making with her fingers the sign of "scissors."

Although this was the theoretical position of woman in Russian society, practically in small households, where women were important factors, there were great divergencies from the strict rules of the *Domostrói*. In the higher ranks of life the women were more carefully guarded and restrained, and

in the family of the Tsar the seclusion in the *Terém*, or women's apartments, was almost complete. This was in part due to a superstitious belief in witchcraft, the evil eye, and charms that might affect the life, health, or fertility of the royal race. Neither the Tsaritsa nor the Princesses ever appeared openly in public; they never went out except in a closed litter or carriage; in church they stood behind a veil,—made, it is true, sometimes of gauze,—and they usually timed their visits to the churches and monasteries for the evening or the early morning, and on these occasions no one was admitted except the immediate attendants of the court. Von Meyerberg, Austrian Ambassador at Moscow in 1663, writes, that out of a thousand courtiers, there will hardly be found one who can boast that he has seen the Tsaritsa, or any of the sisters or daughters of the Tsar. Even their physicians are not allowed to see them. When it is necessary to call a doctor for the Tsaritsa, the windows are all darkened, and he is obliged to feel her pulse through a piece of gauze, so as not to touch her bare hand! Even chance encounters were severely punished. In 1674, two chamberlains, Dashkóf and Buturlín, on suddenly turning a corner in one of the interior courts of the palace, met the carriage of the Tsaritsa Natalia, who was going to prayers at a convent. Their colleagues succeeded in getting out of the way. Dashkóf and Buturlín were arrested, examined, and deprived of their offices, but as an encounter was proved to be purely fortuitous and unavoidable, they were in a few days restored to their rank. And yet, this was during the reign of Alexis, who was far less strict than his predecessors.

The Tsar Basil had married a Polish princess, Helena Glínsky, and during her lifetime—especially during the minority of her son, Iván the Terrible—Polish and western usages crept into the court. The so-called False Dimítരി was eminently liberal-minded, and disposed to accept foreign habits, and had he reigned longer, a much freer life would doubtless have prevailed at the court of Moscow; but he was murdered very soon after his marriage with the Polish Marie Mníshék. Then, with the re-establishment of a national dynasty,—in the Románofs,—came a reaction in an ultra-national sense. It could hardly be otherwise; the father of the Tsar Michael was the Patriarch, and his mother, who had great influence over the young Tsar and long kept him in leading-strings, was a nun, both having been forced

into monastic life during the Troublous Times. The ascetic type of woman prevailed. Of this type the wife of the boyár, Morózof, the great minister of the early part of the reign of Alexis, was a model and pattern. In the latter part of this reign foreign customs began again to edge in, owing in part to the annexation of Kief and Little Russia, and to the influx of teachers educated after Polish and western standards, to the greater intercourse with the west of Europe, and in part to the increasing influence of the "German Suburb," or foreign

brother of King Christian IV., but the bridegroom died of a fever soon after his arrival in Russia, in 1602. The marriage of Irene, the daughter of the Tsar Michael, with the Danish Prince Woldemar, a natural son of Christian IV., was never consummated on account of the refusal of Woldemar to change his religion, although it had been expressly stipulated in the marriage contract that he should not be obliged to do so. The prince was kept a prisoner in Moscow until the death of the Tsar, when he was allowed to return to Denmark. It is an



TEREM, OR WOMEN'S APARTMENT.

colony at Moscow. Of this last I shall have occasion to speak again.

At this time there were a dozen princesses living in the palace,—the sisters and the aunts and the six daughters of the Tsar Alexis. All were unmarried. It was beneath the dignity of the Tsar to bestow his daughter's hand on a subject, and differences of religion and ignorance of the languages and manners of other countries prevented marriages with foreign princes. Since the Tartar invasion only two attempts had been made to marry a Russian princess to a foreigner. Boris Godunóv wished to marry his daughter Xénia to the Danish Prince John,

indirect evidence of the manners of the princesses, that the Russian envoy at Copenhagen, in recounting the good qualities of Irene, praised her particularly for never getting drunk.

All these princesses of the family of Alexis had been brought up in the old style and with the old prejudices. None, except Sophia,—who had shared the lessons of her brother Theodore under the learned Polish monk, Simeon Polótsky,—had more than the rudiments of an education, or knew any language but their own. When the Tsaritsa Natalia Narýshkin, who had been brought up by the wife of Matvéief, a Scotchwoman,

and had seen something of society, entered the palace, it gave a shock, and her words and acts were criticised and disapproved. She was received much as a young Catholic stepmother would be by a large household composed of spinsters brought up with the strictest Presbyterian notions. One of her very first acts—to raise the corner of her carriage curtain so as to see the crowd—provoked such a storm in the household that she was obliged for a long time to be very rigid in her conformity to the palace etiquette. But as time went on the observance of old forms became more lax. The Tsaritsa shared the amusements of the Tsar. In going to and from the country, and even once in a state procession, she rode in an uncovered carriage with the Tsar and one or two of the children. She saw the plays in the palace theater from a latticed box. She witnessed ceremonies and festivities from the corner of some convenient gallery. Lyseck says that the reception of his ambassador took place at Kolómensky solely that Tsaritsa Natalia might see it more easily, and that the procession was made to go slowly past the window where she sat, that she might have more time to observe it. She went openly to church, together with the Tsar, on occasion of the visit of the Patriarchs Paisius and Macarius, and in 1675, at the procession of Holy Thursday, when the Patriarch rode through the Krémelin on an ass, which the Tsar led by the bridle, he turned and blessed the Tsaritsa and the princesses, who were posted at the windows of the banqueting hall.

The household of the Tsar was organized like that of any great noble, though on a larger scale. Of the women's part the Tsaritsa was nominally the head. She had to attend to her own wardrobe, which took no little time, and oversee that of her husband and her children, and had under her direction a large establishment of sewing women. She must receive petitions and attend to cases of charity. She must provide husbands and dowries for the many young girls about her court, and then keep a constant lookout for their interests and those of their families. She had, too, her private estates, the accounts of which she audited, and the revenues of which she collected and expended. What little time was left from household cares and religious duties could be spent in talk, in listening to stories and songs, in laughing at the jests of the court fools, in looking at the amusements of the girls in the play hall, or in

embroidering towels and napkins, robes for the Tsar and princes, and altar-cloths and vestments for the church.

CHAPTER III.

DEATH OF ALEXIS.—GREAT CHANGES.

THE eldest Tsarévitch, Theodore, had in the earlier part of 1674 been declared to be of full age, and had therefore been recognized as heir to the throne, and the Tsar had presented him as such both to his subjects and to the foreigners at Moscow. His health, however, was so delicate that no one expected that he would ultimately reach the throne. The only other living son by the first marriage, Joánn, seemed from his infirmities incapable of reigning, and every one believed that the future successor of Alexis would be Peter. Matvéief in all probability was perfectly convinced of this; and as the Tsar Alexis at this time was only forty-seven, and was in robust health, he allowed events to take their natural course, making no effort to grasp at the succession for his *protégé*. Suddenly, in February, 1676, the Tsar died. On Epiphany, the 16th of January, according to custom, with all the usual ceremony he had taken part in the procession for the blessing of the river Moskvá. On the 22d, the name's-day of his sister Tatiana, he had gone to mass and presented the boyárs with the usual name's-day pasties, filled, as now, with fish. On the 27th there had been at the palace a representation of a comedy, followed by a concert, but the Tsar, feeling unwell, retired during the performance and went to bed. His illness did not seem in the least dangerous, but still increased, and ten days after—the 8th of February—he died, after having given his formal benedictions as his successor to Theodore, who was at that time fourteen years old. In all probability it needed no particular efforts on the part of the daughters of Alexis to bring their father to consecrate the birthright of his eldest son by his blessing. The right of succession to the throne was not strictly fixed by law, but in all Russian families the eldest son succeeded to the father as head of the household, and Theodore, moreover, had the advantage of possession, having been previously formally and publicly proclaimed the heir. The hopes of Matvéief and the Narýshkins rested not on the fitness of Peter, for his brilliant qualities were not yet developed, and he had little more than

good health to recommend him, as on the debility of Theodore and Joánn, who, they thought, would both die long before the Tsar, their father. The story that Matvéief endeavored by a *coup d'état* to set aside Theodore in favor of Peter, is a rumor reported by a badly-informed Polish diplomat, devoid of foundation and disproved by events.

After the burial of Alexis and the coronation of Theodore, everything about the court was changed. The Narýshkins went into retirement and the Miloslávskys came again into power. At first this had but slight effect on public affairs, but a few months later the minister Matvéief, who was the most dangerous rival and antagonist of the Miloslávskys, was suddenly banished, and appointed governor of Verkhoturíe in the northernmost part of Siberia. Matvéief, however, had not succeeded in sailing up the Volga to Léshef, the place where the great Siberian road leaves the river, when he was overtaken with the news that he was accused of an intention to overthrow the Tsar, of dealing with evil spirits, and of the study of magic and witchcraft, by means of a certain black book filled with ciphers (which in the end turned out to be an algebra for the use of his son). He was judged almost as soon as accused, was deprived of all his property and honors, and was exiled as a state criminal, to live in the distant and wild place of Pustozérsk in the province of Archangel. At the same time two of the Tsaritsa's brothers, Iván and Athanasius Narýshkin, were sent into exile; others of her friends were removed from Moscow, and she and her children—for a daughter, Natalia, named after her mother, had been born in 1673, while a second daughter, Theodora, had died in infancy—were placed in a most disagreeable and uncomfortable position. They were sent away from the palace of the Krémelin to live at Preobrazhénsky, a favorite villa of the Tsar Alexis, amid fields and groves, on the river Yaúza, about three miles from the center of Moscow. What, however, at first seemed a misfortune, turned out to be an advantage. The freer life of the country, even though accompanied with a narrow income and many unpleasant circumstances, was better for the development of Peter than would have been the formal life at Moscow. Natalia felt at first that there was danger of Peter becoming a second Dimítri of Úglitch—that unfortunate son of Iván the Terrible, who was murdered in the reign of his

brother, Theodore, by order of Borís Godunóf; but this Theodore was of a mild disposition, and at this time the life of a prince was still held sacred.

CHAPTER IV.

PETER'S FIRST TEACHER.

THE education given to the Russian upper classes at this period seldom consisted of anything more than learning to read, to write, and to sing by note, with some ideas of history, geography, and of the productions of the earth, which were conveyed by means of picture-books: but instruction in grammar, in mathematics, even in arithmetic or in the higher branches of learning, was exceedingly rare, except among the clergy. A high school at which Greek and Latin were taught was in existence at Kíef, but Kíef had only just been re-conquered from the Poles, and was not then definitely part of Russia. Although the influence which this school exercised was gradually felt at Moscow, the Moscow school, on a similar plan, was not started until the reign of Theodore. Even the princes of the royal house received scarcely anything more than this elementary education. Theodore had been exceptionally brought up by the learned monk, Simeon Polótsky, and could speak Polish and Latin. So also could his sister Sophia. The example of the court and the adoption of Polish manners and usages began to affect the aristocracy, and several families at that time had Polish teachers for their children. But so little spread was this influence that, at a time when every Polish and Hungarian gentleman conversed familiarly in Latin, Prince Basil Galítsyn was, according to De Neuville, an exception among Russian statesmen. The son of Matvéief, who had been accompanied in his exile by his teacher, was almost an exception among the children of the age of Peter.

It is probable that such an elementary education was all which Peter would have received had circumstances not interrupted his earlier studies and changed the bent of his mind. A picture-book was ordered to be prepared by one of the Moscow artists for Peter when he was only a year old; an alphabet or primer was given him on the 6th of December, 1675, while his father was still alive, and the next day prayers were said for his success in his studies in the church of St. Nicholas Gostún, as was al-

ways customary in Russia at the time when a child first began to be taught. Peter had preceded by a few days the period fixed by usage for beginning a boy's education—the feast of the prophet Nahum, the 11th of December.

Soon after Theodore ascended the throne,

from which, like other boys of his age, Peter was taught. Besides learning to read, he acquired much by heart, and was able, even at a late period of his life, to recite many passages from the Scriptures. Apparently he learned to write late, for the first copy-books of which we find mention were not given



MURDER OF DIMITRI, SON OF IVAN THE TERRIBLE.

he appointed as teacher for Peter, on the recommendation of the privy-councillor, Theodore Sokóvin, a scribe from the Bureau of Petitions, Nikíta Moiséf Zótof, a man who enjoyed a high reputation for his learning and morality. The Psalter, the Gospels, the Book of Hours were the books

out until 1680, when he was already seven years old, and his handwriting was always extremely bad. At the same time he learned singing by note—an acquirement which in later years frequently afforded him amusement, for in country churches he would enter the chancel and join the choir.



TSAR THEODORE (HALF-BROTHER OF PETER).

Zótof, like a skillful teacher, interspersed his instructions with amusement, and, by a plentiful supply of picture-books, most of which were specially written and illuminated for Peter, and with what were then called "frank leaves,"—that is, German and Italian engravings and wood-cuts,—succeeded gradually in giving his pupil a general knowledge of Russian history, of the deeds of the heroes of early times, of the reigns and wars of the previous Tsars, and some notions of the history of ancient times as well as of Europe, besides a rude idea of natural history.

In this way, between study and play, Peter's life passed on quietly and uneventfully for the six years of the reign of Theodore, the greater part of which was spent at Preobrazhénsky. Although away from the immediate intrigues of the court, yet rumors and agitations reached her country abode, and the Tsaritsa Natalia could never be sure what was in store for her and her children.

Peter doubtless often heard from his mother much sad talk of what she thought their wrongs and their uncomfortable position; much criticism of people in power; many regrets for her protector, Matvéief, with longings for what seemed to her impossible, his return. Boys of Peter's age are quick and intelligent. They keep their ears and eyes open, and they are ever ready with questions. No doubt Peter asked many, and they were answered. The

impressions which were then made on him were deep, and would have been sufficient greatly to have influenced his subsequent life, even without the events that followed.

CHAPTER V.

COURT INTRIGUES IN THEODORE'S REIGN.

AFTER Theodore ascended the throne, the chief personage in the state who had almost supreme power, and who took upon himself the supervision of all the departments of government, was Iván Michailovitch Miloslávsky, a cousin of Theodore's mother. He was supported by the whole of the family influence, and had been recalled from Astrakhán, where, nominally governor, he had been practically an exile. His manners and his assumption made him many enemies, even outside the Narýshkin party, which was naturally disposed against him. The Miloslávskys were not among the number of the old and distinguished families. Dr. Collins says: "Eliah, the present emperor's father-in-law, was of so mean account, that within this twenty years he drew wine to some English men, and his daughter gather'd mushrooms and sold them in the market." The Registers of Services show no entry that the family had ever benefited the state or taken part in public affairs until the marriage of Alexis. During their twenty years' lease of power the Miloslávskys had been arrogant and self-willed. They had not conciliated the old nobility, and now the descendants of Rúrik were



TSAREVITCH JOANN, OR IVAN (HALF-BROTHER OF PETER).

almost in open opposition. Among the discontented were the boyár, Bogdán Hítrovo, Master of the Ordnance, who had been much in the confidence of the Tsar Alexis, and his friend, Prince Yúry Dolgorúky, a powerful nobleman and chief of the Streltsi, or National Guard, neither of whom had been taken into the councils of the new sovereign.

One way which this party took of weakening the power of the Miloslávskys was by getting young men devoted to their interests into place at court, and especially into positions of confidence near the Tsar, thinking that they could thus gradually obtain an influence over him which could be used for their benefit. They particularly put forward in this way Iván Yazýkof and the two brothers Likhatchéf. Whatever the original feelings of these young men may have been toward their supporters, they soon acquired such power over the good-natured but weak-minded Tsar, that they resolved rather to employ it for their own benefit, than for that of those who had raised them to place. In order to increase their influence they determined to marry the Tsar into some family connected with or devoted to their interests, and chose Agatha Grushétsky, a niece of the privy-councillor, Simeón Zborófsky, a nobleman of Polish origin, and managed to give the Tsar a sight of her during a church procession. Theodore, who was then only eighteen, was pleased with the appearance of the young lady and resolved to marry her. At this there was a great outcry on the part of his sisters, who were jealous of new members coming into the family, and also of Miloslávsky, who felt his influence on the wane.

A report was therefore presented to Theodore containing grave accusations against her and her mother. The falsity of these was immediately shown by Yazýkof and the Likhatchéfs; and Miloslávsky was prohibited from appearing at court; although after the marriage, which took place on the 28th of July, 1680, this prohibition was removed at the request of the Tsaritsa. Yet he lost all power and influence. Yazýkof was promoted to the grade of *okólnitchi*, and received the position of Master of the Ordnance in place of his old patron Hítrovo, while the Likhatchéfs became chamberlains. The power thus obtained lasted but a short time, for the Tsaritsa died in child-birth on the 24th of July, 1681, and was followed in a few days by her new-born son.

This event was a terrible blow to the fav-

orites, for the health of Theodore was so delicate, that in case of his death they would find themselves face to face with the Miloslávsky party and the princesses, sisters of Theodore, and would run great danger of exile if not of death. They had alienated their own supporters, Hítrovo and Dolgorúky and their friends, and therefore had no resource except to try to make up to the Narýshkin party and the adherents of Peter. With this view, and in spite of opinions of the physicians as to his health, they proceeded to counsel Theodore to marry again. This time they proposed to him Martha Apráxin, the god-daughter of the ex-minister Matvéief, a girl of 14 years. The first meeting that favored this idea took place in December of that year; and the chosen bride (as no doubt she had been instructed) immediately asked the Tsar to alleviate the fate of her god-father Matvéief, who, up to this time, had vainly written petitions showing his innocence. The sentence was quashed; the property and the estates of Matvéief were returned to him, and in addition, he was given the village of Landékh, and was commanded to wait for further orders at the town of Lukh, near Kosáomh, on the Volga.

CHAPTER VI.

THE DEATH AND FUNERAL OF THEODORE. —ELECTION OF PETER AS TSAR.

BUT these orders were not to come from Theodore, who had become feebler from day to day, and who died two months and a half after his second marriage, on the 7th of May, 1682. The death of Theodore left two possible candidates for the throne: Iván or Joánn, the elder brother, the son of the Tsar Alexis by his first wife, Marie Miloslávsky, who was blind, lame, and half idiotic; and the son of Natalia Narýshkin, the strong, healthy, and clever Peter. Although there was no law regulating the succession to the throne, except that it should be hereditary in the Románof family, yet primogeniture was consecrated by usage. Theodore had appointed no other successor, and Iván had therefore the greater right to the throne. But the accession of Iván would render necessary a continued regency, and that regency would naturally be influenced by his uncle and cousins, the Miloslávskys. The Miloslávsky family was not popular among the aristocracy, and this very fact disposed many of the nobles to take the side of Peter. To be sure, even under Peter the

public affairs for a long time would be in the hands of Matvéief; but Matvéief was a man who had never offended the great nobles, either by his manners toward them or by the introduction of any reforms trenching upon their privileges. He employed them, as far as he could; at all events, he respected their rank, and so few of them at that time were fit to take part in public affairs that this was all they cared for. Only two great magnates took the side of Iván—Prince Basil Vasiliévitch Galítsyn and Prince Iván Andréievitch Havánsky. Galítsyn had been brought into great antagonism to the aristocracy by the part he had played in the reform movement under Theodore, of which I shall speak presently; but there is also some reason to believe that he was already in such intimate personal relations with the Princess Sophia, of whom he was afterward the acknowledged lover, that he saw through her means, in case of the election of Iván, the possibility of his rising to the highest power and influence in the state. Prince Havánsky, an empty and addle-pated man, of no special ability, greatly prided himself on his descent from King Gédimin of Lithuania, and had a great opinion of his own personal importance. Without any claim to important public positions, his life had been passed in continual surprises that the high places of state were, one after the other, filled by some one other than Prince Havánsky. He had been deprived of command at Pskof—the only important position he had ever held—for cruelty, immorality, and notorious incompetency, and the Tsar Alexis had said to him, “Though I picked you out and put you into service, everybody calls you a fool.” Without ideas, he talked incessantly, bustled noisily about with no definite object, and was such a braggart and boaster that he acquired the popular nickname of *Tavarlí*, expressive at once of the inconstancy of the weather-cock and the exultation of the barn-yard fowl. These characteristics were perhaps inherited; at all events they have been transmitted to some of his descendants. As he had nothing to hope from Matvéief and the Narýshkins for himself, and consequently for Russia, he opposed Peter and took the side of Iván. The sisters of Theodore and the Miloslávsky party had, therefore, little support to expect for their candidate in the council which would decide the election of the Tsar, for, under the circumstances, it was felt that nothing less than a ratification by the representatives of all Russia, as in the case of the

election of Michael, would fix the crown on Peter's head without the liability to further disputes. But as the Miloslávskys had not been sparing of the step-mother and her children in the moment of their triumph, during the early part of the reign of Theodore, they had to fear the worst, and therefore had to do something in self-defense. By a plentiful use of money and promises, they won over a number of “young men,”—that is, persons without high position, but who, nevertheless, could exercise considerable influence,—some courtiers, others delegates of the Streltsi, or National Guard, among which there was a great deal of discontent. Their plans, however, were not yet matured when Theodore died. Many of the aristocratic party, which used the name of Peter for their watchword, ascertaining the movements of the Miloslávskys, feared that the election would result in bloodshed, and came to the palace with coats of mail under their gowns. This time, however, there was no trouble.

When all, according to custom, had given a farewell kiss to the hand of the dead Theodore, and had paid their salutations to Princes Iván and Peter, the Patriarch, the archbishops, and the abbots of the chief monasteries came into the anteroom. The Patriarch, who was himself a boyár, belonging to the Sabéliéf family, put to the assembled nobles the question: “Which of the two Princes shall be Tsar?” The nobles at once replied that this should be decided by the people of all the ranks of the Muscovite state. Now delegates from the whole country, two from each district, were in Moscow, having come on the summons of Theodore, in order at a session of the States-General to decide on a fundamental reform of the tax system. No pains, however, were taken to collect these delegates, and the nobles meant by their words merely their adherents, who had collected in the Great Square of the Krémelin, adjoining the palace. The Tsar Shúfsky had been overturned because he was elected by Moscow alone, and, therefore, the States-General were convened when Michael Románof was chosen. The “Muscovite State” therefore meant, practically, a Moscow crowd.

The Patriarch and the archbishops then proceeded to the balcony overlooking the Grand Square of the Krémelin, in front of the church of the Saviour, and the question was again put: “To which of the two Princes do you give the rule?” There were loud cries everywhere of “Peter

Alexévitch," there were some cries of "Iván Alexévitch," but these were soon drowned. The matter was thus decided by the crowd of people of all ranks; and the Patriarch returned into the palace, and gave his blessing to Peter as Tsar. The name of only one person who shouted for Iván is known,—Maxini Sumbúlof,—and an anecdote is told of his subsequent meeting with Peter. Once when at mass at the Miracle monastery, Peter noticed that one monk did not go up to receive the *antidoron*, or morsels of holy bread distributed at the end of the mass. Peter asked who he was, and was told it was Sumbúlof. He then called the monk, and asked him why he did not receive the *antidoron*. The monk answered: "I did not dare to go by you, Lord, and raise my eyes to you." The Tsar bade him go for the *antidoron*, and subsequently calling him again asked: "Why did I not suit you in the election for Tsar?" The monk replied: "Judas sold Christ for thirty pieces of silver, although he was his disciple; and I, Lord, was never your disciple. Is it strange, then, that I—a petty nobleman—should sell you to become a boyár?"

All this was in the spring of 1682, when the Whigs were conspiring against Charles the Second, three years before the Revocation of the Edict of Nantes, and a year after Strasburg and Alsace had been annexed by Louis XIV., the same year that William Penn was colonizing Pennsylvania and La Salle exploring Louisiana.

The election was decided; Peter was Tsar, and by custom, the step-mother, as head of the family, was the regent. What could the princesses and the Miloslávsky party do? Pretense was useless; open opposition was the expression almost of despair. On the

day of the funeral of Theodore, the Princess Sophia insisted, contrary to all etiquette, on accompanying the body to the church. Remonstrances were vain. She not only went, disregarding the Byzantine prescriptions which kept the princesses unseen behind a canopy, showing herself openly to the people, but she was also loud in the expression of her grief, which was certainly sincere and not feigned. At last, long before the ceremonies had terminated, the widowed step-mother, Natalia, left the church, leading her son Peter. This excited remark, not only among the populace, but still more on the part of the Princess Tatiana, the eldest member of the family, the sister of the Tsar Alexis and the aunt of Theodore, highly respected for her charity and goodness, who sent at noon a message to Natalia, saying: "You're a fine relation,—could not wait till the end of the funeral." Natalia excused herself on the ground that Peter was so young that it would have been injurious to his health to have remained in church so long without eating. Her cousin, Iván Narýshkin, who had just returned from exile, and was constantly causing trouble by his thoughtless remarks, said "Let him that is dead lie there. His Majesty the Tsar is not dead, but still lives." On returning from the funeral Sophia wept bitterly, and turning to the people cried out: "You see how our brother the Tsar Theodore has suddenly gone from this world. His ill-wishers and enemies have poisoned him. Have pity on us orphans. We have no father nor mother nor brother. Our eldest brother Iván has not been elected Tsar, and if we are to blame before you and the boyárs, let us go live in other lands which are ruled over by Christian Kings." These words naturally produced a deep impression.

(To be continued.)

SUCCESS WITH SMALL FRUITS. IV.

A SOUTHERN STRAWBERRY FARM.

HAVING treated of the planting of strawberries, their cultivation, and kindred topics, in that great northern belt, of which a line drawn through New York city may be regarded as the center, I shall now suggest characteristics in the culture of this fruit in southern latitudes. We need not refer to the oldest inhabitant, since the middle-aged

remember when even the large cities of the North were supplied from the fields in the suburbs, and the strawberry season in town was identical with that of the surrounding country. But a marvelous change has taken place, and berries from southern climes appear in our markets soon after midwinter. This early supply is becoming



THE HOME FIELD AND MR. YOUNG'S COTTAGE.

one of the chief industries of the South Atlantic coast, and every year increases its magnitude. At one time, southern New Jersey furnished the first berries, but Maryland, Delaware, and Virginia soon began to compete. Norfolk early took the lead in this trade, and even before the war was building up a fine business. That event cut off our Southern supply, and for a few years June and strawberries again came together. But after the welcome peace, many south-

in our midwinter, and with its quick, sandy soil and sunny skies, threatens to render the growing of this fruit under glass unprofitable.

I think I can better present the characteristics of strawberry culture in the South by aiming to give a graphic picture of the scenes and life on a single farm than by general statements of what I have witnessed here and there. I have therefore selected for description a plantation at Norfolk, since this city is the center of the largest trade and is nearly midway in the Atlantic strawberry belt. I am also led to make this choice because here is to be found, I believe, the largest strawberry farm in the

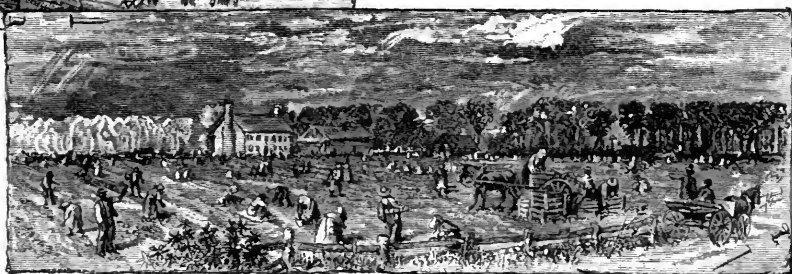

THE FIRST GLIMPSE.

ern fields grew red once more, but not with blood, and thronged, but chiefly by women and children. Soil, climate, and superb water communications speedily restored to Norfolk the vantage which she will probably maintain; but fleet steamers are giving more southern ports a chance. Charleston, South Carolina, is only second in importance. In the spring of '79 every week four steamers were loaded for New York, and strawberries formed no insignificant proportion of the freight.

world, and its varied labors illustrate most of the southern aspects of the question.

And now Florida, which has already produced unrivaled oranges, is beginning to furnish tons of strawberries, that begin ripening

We had not proceeded very far from Norfolk before we saw in the distance a pretty cottage sheltered by a group of tall, primeval



AN OVERSEER—A "LITTLE BRIEF AUTHORITY."

pinus, and on the right of it a large barn-like building, with dwelling, office, smithy, sheds, etc., grouped about it. A previous visit enabled me to point out the cottage as the home of the proprietor, and to explain that the seeming barn was a strawberry crate manufactory. As was the case on large plantations in the olden time, almost everything required in the business is made on the place, and nearly every mechanical trade has a representative in Mr. Young's employ.

As we drove up under the pines, the proprietor of the farm welcomed us with cordial hospitality. There was the farm we had come to see, stretching away before us in hundreds of green, level acres. As we drove to distant field in which the pickers were then engaged, we could see the ripening berries with one side blushing toward the sun. Passing a screen of pines, we came out into a field containing thirteen acres of Duncan strawberries, and then we began to realize more fully the magnitude of the business. Scattered over the wide area, in what seemed inextricable confusion to our uninitiated eyes, were hundreds of men, women, and children of all ages and shades of color, and from the field at large came a softened din of voices, above the monotony of which arose here and there snatches of song, laughter mellowed by distance, and occasionally the loud, sharp orders of the overseers, who stalked hither and thither, wherever their

little brief authority was most in requisition.

We soon noted that the confusion was more apparent than real, and that each picker was given a row over which he—or, more often, she—bent with busy fingers until it was finished. At central points crates were piled up, and men known as "buyers" received the round quart baskets from the trays of the pickers. While wide platform carts, drawn by mules, were bringing empty crates and carrying away those that had been filled.

Along the road that skirted the field and against a pretty background of half-grown pines, motley forms and groups were moving to and fro, some seeking the "buyers" with full trays, others returning to their stations in the field with a new supply of empty baskets. Some of the pickers were drifting away to other fields, a few seeking work late in the day, more bargaining with the itinerant vendors of pies (made to last all summer if not sold), gingerbread, "pones," and other nondescript edibles at which an ostrich would hesitate in well-grounded fear of indigestion, but for which sable and semi-sable pickers exchange their berry tickets and pennies as eagerly as we buy Vienna rolls. Flitting to and fro were numberless colored children, bare-headed, bare-legged, and often with not a little of their sleek bodies gleaming through the innumerable rents of their garments, their eyes glit-

tering like black beads, and their white teeth showing on the slightest provocation to mirth. Indeed, the majority of the young men and women were chattering and laughing much of the time, and only those well in the shadow of age worked on in a stolid, plodding manner. Over all the stooping, moving, oddly appareled forms, a June-like sun was shining with summer warmth. Beyond the field a branch of Tanner's Creek shim-

Our artist was quick to see a good subject, and almost in a flash he had the man posed and motionless in his attitude of authority, and under his rapid strokes Jackson won fame and eminence, going to his task a little later the hero of the field.

While the sun had been shining so brightly there had been an occasional heavy jar and rumble of thunder, and now the western



SELLING CAKES AND ICE WATER.

mered in the light; tall pines sighed in the breeze on the right, and from the copse-wood at their feet quails were calling, their mellow whistle blending with the notes of a wild Methodist air. In the distance rose the spires of Norfolk, completing a picture whose interest and charm I have but faintly suggested.

Several of the overseers are negroes, and we were hardly on the ground before one of these men in the performance of his duty, shouted in a stentorian voice.

"Heah, you! Git up, dar, yo' long man, off 'n yo' knees. What yo' mashin' down a half acre o' berries fer?"

sky was black. Gradually the pickers had disappeared from the Duncan field and we at last followed them, warned by an occasional drop of rain to seek the vicinity of the house. Having gained the grassy slope beneath the pines in the rear of the dwelling, we turned to note the pretty scene. A branch of Tanner's Creek came up almost to our feet, and on either side of it stretched away long rows of strawberries as far as the eye could reach. Toward these, the throng of pickers now drifted, "seeking fresh fields and pastures new." The motley crowd was streaming down on either side of the creek, while across a little causeway came a coun-

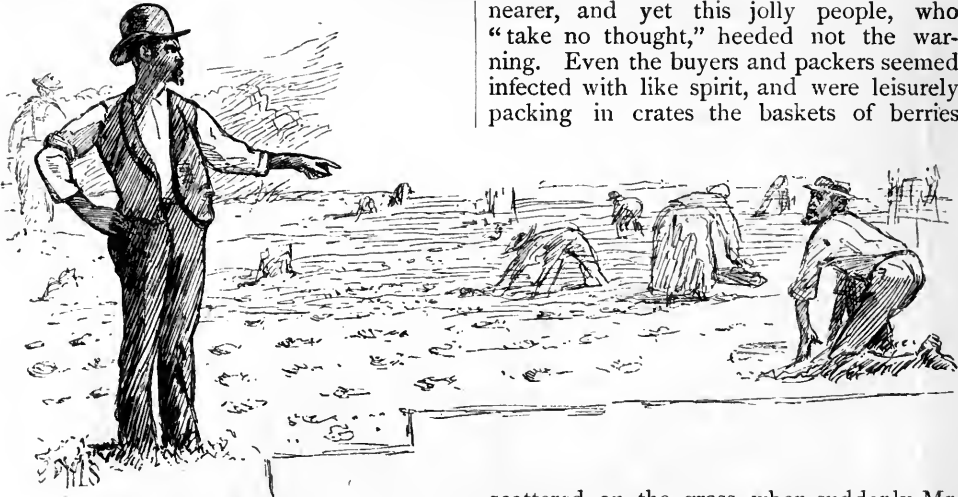

"GIT UP, DAR, YO' LONG MAN,
OFF'N YO' KNEES."

ter current, the majority of them having trays full of berries. The buyers, like the traders with the nomad Indians, open traffic anywhere and at the shortest notice. A mulecart was stopped, a few empty crates taken off and placed under the pines at our feet, and soon the grass was covered with full quart baskets, for which the pickers received tickets and then passed on, or, as was often the case, threw themselves down into the shade. The itinerant venders came flocking in like so many buzzards. There was at once chaffering and chaffing, eating and drinking. All were merry. Looking on the groups before us one would not have dreamed that there was a cloud in the sky. Every moment the thunder was jarring and rolling

nearer, and yet this jolly people, who "take no thought," heeded not the warning. Even the buyers and packers seemed infected with like spirit, and were leisurely packing in crates the baskets of berries

scattered on the grass, when suddenly Mr. Young, with his fleet, black horse, came flying down upon us. Standing up in his buggy he gave a dozen rapid orders like an officer on the field in a critical moment. The women who had been lounging with their hands on their hips, shuffle off with their trays; half burned pipes are hastily emptied; gingerbread, and like delicacies, are stuffed into capacious mouths, since hands must be employed at once. Packers, mules, everybody, everything, are put upon the double-quick to prepare for the shower.

The cloud did not prove a passing one, and the rain fell so long and copiously that further picking for the day was abandoned. Some jogged off to the city, at a pace that nothing but a fierce storm could have quickened. A hundred or two remained under

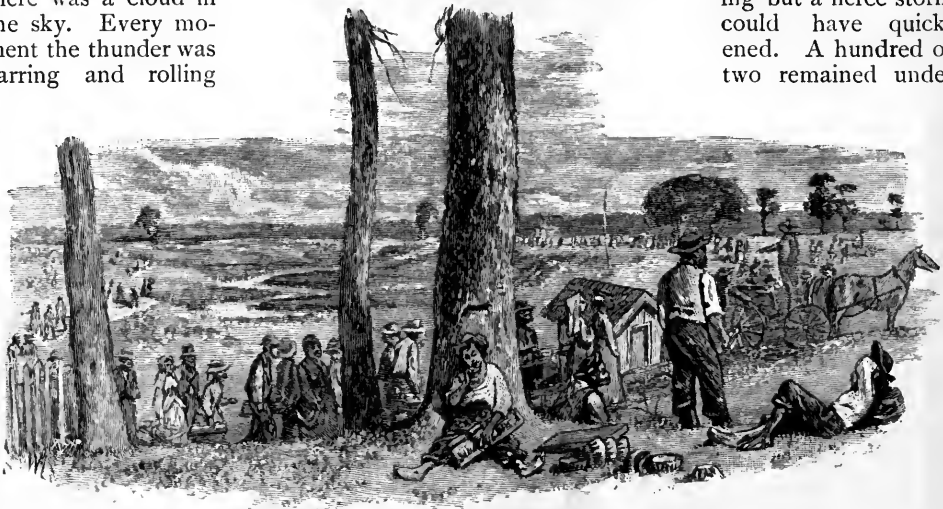

the sheds, singing and laughing. Men and women, and many bright young negro girls, too, lit their pipes, waiting till they could gather at the "paying booth," near the entrance of the farm, when the rain was over. This booth is a small shop, extemporized of rough boards by an enterprising grocer of the city. One side is open, like the counter of a restaurant, and within upon the grass, as yet untrodden, are barrels and boxes con-

people say. Here was a large and well-developed business, which proved the presence of no small degree of brain power and energy.

Mr. J. R. Young, Jr., is a veteran in strawberry culture, although but twenty-nine years of age. He has under his control a farm of 440 acres, 150 of which are to-day covered with bearing strawberry plants. In addition, he has set out this spring over two million



EXCHANGING AND COUNTING TICKETS.

taining the edible enormities which seem indigenous to the semi-grocery and eating-house. In most respects the place resembled the sutler's stand of our army days. There was a small window on one end of the booth, and at this sat the grocer, metamorphosed into a paymaster, with a huge bag of coin, which he rapidly exchanged for the strawberry tickets. Our last glimpse of the pickers, who had streamed out of the city in the gray dawn, left them in a long line, close as herrings in a box, pressing toward the window, from which came faintly the chink of silver.

As night at last closed about us, we realized the difference between a strawberry farm and a strawberry bed, or "patch," as country

more plants, which will occupy another hundred acres, so that in 1880 he will have 250 acres that must be picked over almost daily.

In operations upon a large scale Mr. Young prefers spring planting. Such a choice is very natural in this latitude, for he can begin setting the first of February and continue until the middle of April. Nine-tenths of the plants grown in this region are set out in spring. But at Charleston and farther south they reverse this practice and, with few exceptions, plant in the summer and fall, beginning as early as July on some places, and continuing until November.

I must also state that the finest new plantation that I saw on Mr. Young's place

was a field of Seth Boydens set out in September. This fact proves that he could follow the system of autumn planting successfully, and I am inclined to think that he will regard this method with constantly increasing favor. I know of a gentleman who planted 96,000 in Richmond in October, 1877, and in the following spring there was scarcely a break in the long rows and nearly fruit enough, I think, to pay the

by hand. On the rim of these wheels are two knobs shaped like an acorn. Each wheel marks a continuous line on the soft earth, and with each revolution the knobs make two slight but distinct depressions twelve inches apart; or, if the variety to be planted is a vigorous grower, another set of wheels is used that indent the ground every fifteen inches. A plant is dropped at each indentation, and a gang of colored

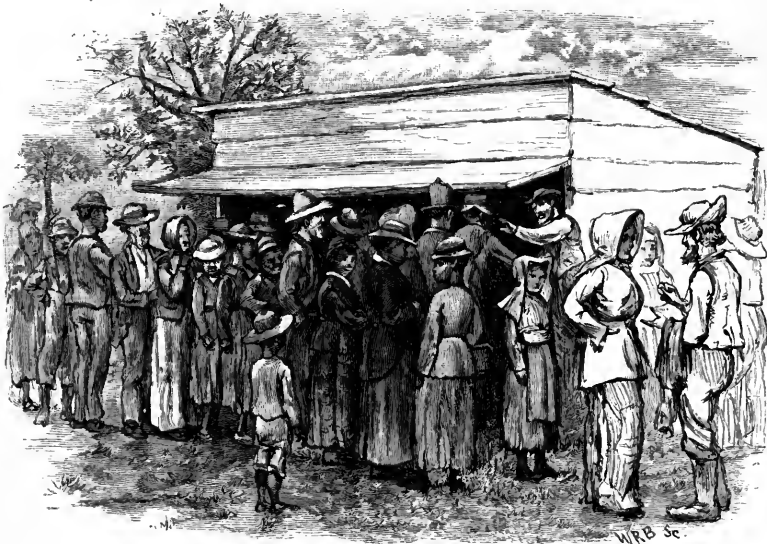

PAYING OFF HANDS.

cost of the plants. From his Seth Boydens, set out last September, Mr. Young will certainly pick enough berries to pay expenses thus far, and at the same time the plants are already four times the size of any set out this spring. As the country about Norfolk is level, with spots where the water would stand in very wet weather, Mr. Young has it thrown up into slightly raised beds two and a half feet wide. This is done by plows after the ground has been thoroughly prepared and leveled by a heavy fine-toothed harrow. These ridges are but four or five inches high and are smoothed off by an implement made for the purpose. Upon these beds quite near the edges the plants are set in rows twenty inches apart, while the depressed space between the beds is twenty-seven inches wide. This space is also designed for the paths. The rows and the proper distances for the plants are designated by a "marker," an implement consisting of several wheels fastened to a frame and drawn

women follow with trowels, and by two or three quick, dexterous movements imbed the roots firmly in the soil. Some become so quick and skillful as to be able to set out six or seven thousand a day, while four or five thousand is the average. With his trained band of twenty women Mr. Young calls the setting of a hundred thousand a good day's work.

The labor of weeding is reduced to a minimum by mule cultivation, and Mr. Young has on his farm a style of cultivator that is peculiarly adapted to the work. As this is his own invention, I will not describe it, but merely state that it enables him to work very close to the rows and to stir the soil deeply without moving it or covering the plants. These cultivators are followed by women with light, sharp hoes, who cut away the few weeds left between the plants. They handle these tools so deftly that scarcely any weeding is left to be done by hand, for by a rapid encircling stroke they cut within a half inch of the plant. For several years

past, I have urged upon Mr. Young the advantage of the narrow row or hill system, and his own experience has led him to adopt it. He is now able to keep his immense farm free of weeds chiefly by mule labor, whereas, in his old system of matted row culture it was impossible to keep down the grass, or prevent the ground from becoming hard and dry. He now keeps all his plants in hills or "stools," from twelve to fifteen inches apart. The runners are cut from time to time with shoe-knives, the left hand gathering them up by a single rapid movement and the right hand severing them by a stroke. To keep his farm in order, Mr. Young must employ seventy-five hands through the summer. The average wages for women is fifty cents, and for men seventy-five to ninety cents. With the advent of autumn, the onslaught of weeds gradually ceases, and there is some respite in the labors of a Virginia strawberry farm.

At Charleston and farther south this respite is brief, for the winters there are so mild that certain kinds of weeds will grow all the time, and early in February they must begin to cultivate the ground and mulch the plants for bearing.

Bordering on Mr. Young's farm and farther up the creek there are hundreds of acres of salt meadows. From these he has cut in the autumn and early winter two hundred tons of hay, and with his lighter floats it down to his wharf. In December, acre after acre is covered until all the plants are quite hidden from view. In the spring this winter mulch is left upon the ground as the summer mulch, the new growth in most instances pushing its way through it readily. When it is too thick to permit this it is pushed aside from the crowns of the plants. Thus far Mr. Young has given the bearing fields no spring culture, adopting the common theory that the ground around the plants must not be disturbed at this season. I advocate the opposite view, and believe in *early* spring culture, as I have already explained, and I think his experience this year will lead him to give my method a trial in 1880. The latter part of April and early May was very dry at Norfolk, and the ground between the bearing plants became parched, hard, and in many instances full of weeds that had been developing through the long, mild spring of this region. Now I am satisfied that if he, and all others in this region who adopt the narrow row system, would loosen the ground deeply with

a subsoil plow *early* in the season, before the plants had made much growth, and then stir and pulverize all the surface between the plants in the rows, they would increase the size and quantity of the berries at least one-third, and in many instances double the crop. It would require a very severe drouth, indeed, to injure plants thus treated, and it is well known, also, that a porous, mellow soil will best endure too frequent rains. I have sometimes thought that light and air are as indispensable to the roots of plants as to the foliage.

The winter mulch need not prevent this spring culture. Let the men begin on one side of a field and rake inward until half a dozen rows are uncovered. Down through these the subsoil plow and the cultivator can pass. Then the hay can be raked back again and a new space cleared, until the whole field is cultivated and the mulch left as it was before. Now, however, it is not a surface like hard pan that is covered, but a mellow soil in which the roots can luxuriate.

Mr. Young uses fertilizers, especially those containing ammonia, only to a limited extent, believing that while they undoubtedly increase the size of the fruit, they also render it soft and unfit for long carriage, and promote an undue growth of vine. This theory is true, to a certain extent, but I think the compensating benefits of fertilizers of almost any kind, far outweigh the disadvantages. At his distance from the market firmness in the berry is essential, but I think he will find this quality is dependent more upon the weather and the variety than upon the fertilizer. Of course, over-stimulation by hot manures will always produce an unwholesome, perishable growth, but a good coat of well-rotted compost scattered down the rows just before they receive their spring culture would be exceedingly beneficial in nine cases out of ten. I most heartily agree with him, however, that all fertilizers containing potash are peculiarly adapted to the strawberry.

When we reached the farm the next morning the pickers were beginning to take possession of a field containing thirty acres of *Triomphe de Gands*, and we followed them, and there came across one of the oddest characters of the plantation—"Sam Jubilee," the "row-man," black as night, short, stout, and profane. It is Sam's business to give each picker a row of berries, and he carries a brass-headed cane as the baton of authority. As we came up he was whirling

a glazed hat of portentous size in one hand, and gesticulating so wildly with his cane that one might think he was in convulsions of rage, but we soon learned that this was "his way."

"Heah, you dah!" he vociferated, to the slouching, leisurely pickers that were drifting after him, "what's de matter wid yer j'intis? Step along lively, or, by——" and then came a volley of the most outlandish oaths ever uttered by a human tongue.

dat row. You gemlin" (to a white man) "take dat. Heah, chile, step in dar an' pick right smart, or I'll warm yer!"

Sam "brothers" and "sisters" the motley crowd he domineers like a colored preacher, but I fear he is not "in good and regular standing" in any church in Norfolk.

"He can give out rows more rapidly and systematically than any man I ever had," said Mr. Young, and we soon observed that wherever Jubilee led with his stentorian voice and emphatic gestures there was life and movement.

Passing to and fro across the fields are the two chief overseers of the farm, Harrison and Peters, both apparently full-blooded negroes, but, in the vernacular of the south, "right smart men." They have been with Mr. Young eight or ten years, and were promoted and maintain their position solely on the ground of ability and faithfulness. They go rapidly from one to another, noting whether they are picking the rows clean. They also take from each tray a basket at random, and empty it into another, thus discovering who are gathering green or imperfect berries. If the fruit falls much below the accepted standard, the baskets are confiscated and no tickets given for them, and if the picker continues careless he is sent out of the field. Mr. Young says that he has never found any white overseers who could equal these men, and through the long year they drive along the work with tireless energy.

To the majority the strawberry season brings the halcyon days of the year. They look forward to it and enjoy it as a prolonged picnic, in which

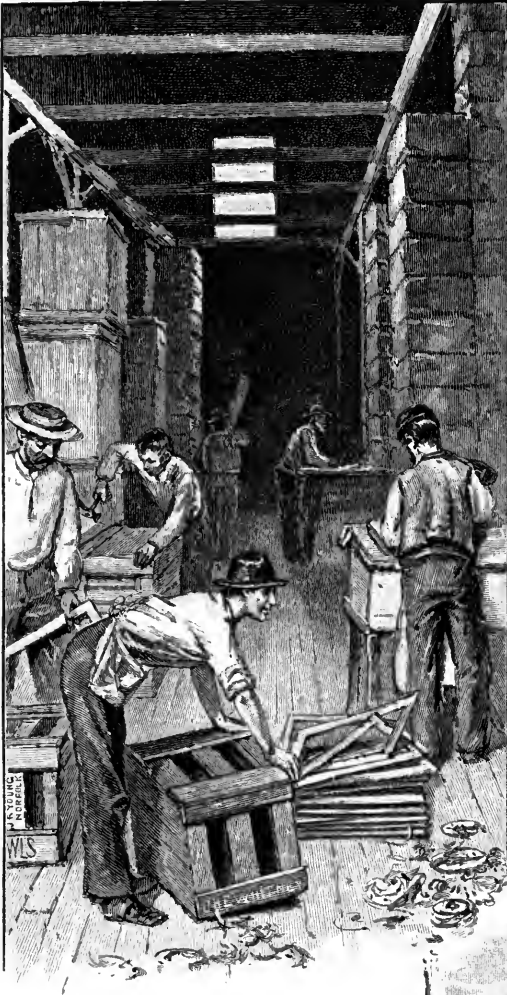

MAKING CRATES.

"Don't swear so, Sam," said Mr. Young.

"Can't help it, sah. Dey makes me swar. Feels as if I could bust into ten thousand emptin's, dey's so agerwatin. Heah, my sister, take

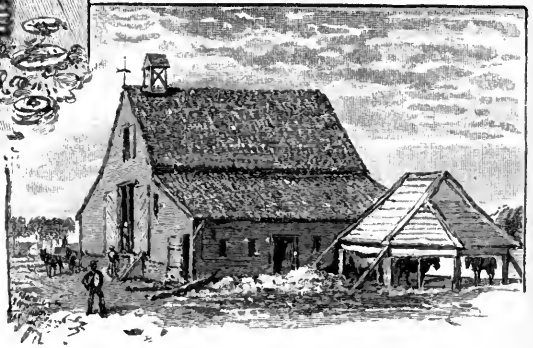

EXTERIOR OF FACTORY.

business and pleasure are equally combined. They are essentially gregarious, and this industry brings many together during the long bright days. The light work leaves their tongues free, and families and neighbors pick together with a ceaseless chatter, a running fire of rude, broad pleasantry, intermingled occasionally with a windy war of words in a jargon that becomes all the more uncouth from anger, but which rarely ends in blows.

We were continually impressed by their courage, buoyancy, animal spirits, or whatever it is that enables them to face their uncertain future so unconcernedly. Multitudes live like the birds, not knowing where their next year's nest will be, or how tomorrow's food will come. It *has* come thus far, and this fact seems enough. In many instances, however, their humble fortunes are built on the very best foundations.

Scattered here and there over the fields might be seen two heads that would keep in rather close juxtaposition up and down the long rows.

"Dey's pairin' off," was the explanation.

"You keep de tickets," said a buxom young woman to her mate, as he was about to take her tray, as well as his own, to the buyers.

"You are in partnership," I remarked.

"Yes, we is," she replied, with a conscious laugh.

"You are related, I suppose?"

"Well, not 'zackly—dat is—we's partners."

"How about this partnership business—does it not last sometimes after the strawberry season is over?"

"Oh, Lor', yes! Heaps on 'em gits fallen in love; den dey gits a-marryin', arter de pickin' time is done gone by."

"Now I see what your partnership means."

"Yah, yah, yah! You sees a heap more dan I's told you!" But her partner grinned most approvingly. We were afterward informed that there was no end to the love-making among the strawberry rows.

There are from fifty to one hundred and fifty pickers in a squad, and these are in charge of subordinate overseers, who are continually moving around among them, on the watch for delinquencies of all kinds. Some of these minor potentates are white and some black. As a rule, Mr. Young gives the blacks the preference, and on strictly business principles, too. "The colored men have more snap, and can get more work out of their own people," he says. By means of these sub-overseers, large numbers



SOME BASKETS.

can be transferred from one part of the farm to another without confusion.

Fortunes are never made in gathering strawberries, and yet there seems no dearth of pickers. Five or six thousand bushels a day are often gathered in the vicinity of Norfolk, and the pickers rarely average over a bushel each.

As has been already suggested, the pickers are followed by the buyers and packers, and to these men, at central points in the fields, the mule-carts bring empty crates. The pickers carry little trays containing six baskets, each holding a quart. As fast as they fill these, they flock in to the buyers. If a trayful, or six good quarts, are offered, the buyer gives the picker a yellow ticket, worth twelve cents. When less than six

baskets are brought, each basket is paid for with a green ticket, worth two cents. These two tickets are eventually exchanged for a white fifty-cent ticket, which is cashed at the paying-booth after the day's work is over. The pickers therefore receive two cents for every quart of good salable berries. If green, muddy, or decayed berries are brought in, they are thrown away or confiscated, and incorrigibly careless pickers

through before they can get a cent. Peters and Harrison see to it that none are laying around in the shade, and thus, through the compulsion of system, many, no doubt, are surprised to find themselves at work for the greater part of the day.

And yet neither system nor Peters, even with his sanguinary reputation, is able alone to control the hordes employed. Of course the very droves of the population are largely

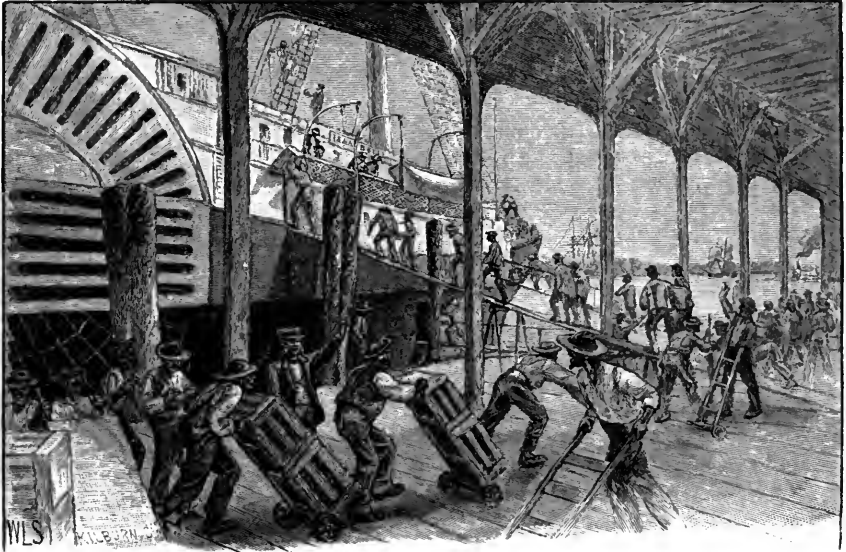

RUSHING THE LAST LOT.

are driven off the place. Every morning the buyers take out as many tickets of these three values as they think they can use, and are charged with the same by the book-keeper. Their voucher for all they pay out is another ticket, on which is printed "Forty-five quarts," or just a crateful. Only Mr. Young and one other person have a right to give out the last-named tickets, and by night each buyer must have enough of them to balance the other tickets with which he was charged in the morning. Thus thousands of dollars change hands through the medium of four kinds of tickets not over an inch square, and by means of them the financial business of the whole gathering of the crop is managed.

Mr. Young requires that no tickets shall be cashed until the fields have all been picked over. Were it not for this regulation, the lazy and the "bummers" would earn enough merely to buy a few drinks, and then slink off. Now they must remain until all are

represented. Many go out on a "lark," not a few to steal. Walking continually back and forth through the fields, therefore, are two duly authorized constables, and only their presence prevents a great deal of crime. Moreover, according to Virginian law, every landholder has the right to arrest thieves and trespassers. Up to the time of our visit five persons had been arrested, and the fact that they were all white does not speak very well for our color. The law of the state requires that theft shall be punished by so many lashes, according to the gravity of the offense and by imprisonment. Such ignominious punishment may prevent theft, but it must tend to destroy every vestige of self-respect and pride in criminals and render them hopelessly reckless.

Mr. Young says that the negro laborers are easily managed and will endure a great deal of severity if you deal fair with them; but if you wrong them out of even five cents they will never forget it. More-

over, every citizen of "Blackville" will be informed of the fact, for what one knows they all seem to know very soon.

We were not long in learning to regard the strawberry farm as a little world within itself. It would be difficult to make the reader understand its life and "go" at certain hours of the day. Scores are coming and going; hundreds dot the fields; carts piled up with crates are moving hither and thither. At the same time the regular toil of cultivation is maintained. Back and forth between the young plants mules are drawing cultivators, and following these come a score or two women with light sharp hoes. From the great crate manufactory is heard the whir of machinery and the click of hammers; at intervals the smithy sends forth its metallic voice, while from one center of toil and interest to another the proprietor whisks in his open buggy at a speed that often seems perilous.

During a rainy day, when driven from the field, we found plenty to interest us in the printing office, smithy, and especially in the huge crate manufactory. Here were piled up coils of baskets that suggested strawberries for a million supper tables. Hour after hour the mule-power engine drove the saws through the pine boards that soon became crates for the round quart baskets. These crates were painted green, marked with Mr. Young's name, and piled to the lofty, cob-webbed ceiling. It requires several of them to hold two or three millions of baskets.

But Saturday is the culminating point of the week. The huge plantation has been gone over closely and carefully, for on the morrow the birds will be the only pickers. Around the office, crate manufactory, and paying booth were gathered over a thousand people—a motley and variegated crowd that only the South can produce. The odd and often coarse jargon, the infinite variety in appearance and character suggested again that humanity is a tangled problem. The shrewdness and accuracy, however, with which the most ignorant count their tickets and reckon their dues on their fingers is a trait characteristic of all, and having received the few shillings, which mean a luxurious Sunday, they trudge off to town, talking volubly, whether any one listens or not.

But many cannot resist the rollicking music back of the paying booth. Three sable musicians form the orchestra, and any one, white or black, can purchase the privilege of keeping step to the music for two cents, or one strawberry ticket. Business was superb, and every shade of color and character was represented. In the vernacular of the farm, the mulatto-girls are called "strawberry blondes," and one that would have attracted attention anywhere, was led out by a droll, full-blooded negro, who would have made the fortune of a minstrel troupe. She was tall and willowy. A profusion of dark hair curled about an oval face, not too dark to prevent a faint color of the strawberry to glow in her cheeks. She wore neither hat nor shoes, but was as unembarrassed, apparently, in her one close-fitting garment as could be any ball-room belle dressed in the latest mode. Another blonde, who sported torn slippers and white stockings, was in danger of being spoiled by much attention. As a rule, however, bare feet were nothing against a "lady" in the estimation of the young men. At any rate, all who could spare a berry ticket speedily found a partner, and, as we rode away from the farm, the last sounds were those of music and merriment, and our last glimpse was of the throng of dancers on the green.

The confused uproar and rush of business around the Old Dominion steamship made a marked contrast. To the ample wharves every species of vehicle had been coming all day, while all kinds of craft, from a skiff to a large two-masted schooner, awaited their turn to discharge their freight of berry crates and garden produce, the line reaching half across the Elizabeth River. The rumble of the trucks was almost like the roar of thunder, as scores of negroes hustled crates, barrels, and boxes aboard.

As the long twilight fades utterly into night, the last crate is aboard. The dusky forms of the stevedores are seen in an old pontoon-shaped boat on their way to Portsmouth, but their outlines and the melody of their rude song are soon lost in the distance. The ship, that has become like a huge section of Washington Market, casts off her lines, and away we steam, diffusing on the night air the fragrance of a thousand acres, more or less, of strawberries.

JOHN BRIGHT.



JOHN BRIGHT.

JOHN BRIGHT was the son of Jacob Bright, a cotton spinner of Rochdale, who owned a mill in that town. He was born in his father's house at Greenbank, a suburb of Rochdale, in the year 1811. Rochdale is a town in Lancashire, not very far to the north of Manchester. This is a region which has now become known to the world as the stronghold of English liberalism, not to say radicalism. South Lancashire,

however, was, until within a period comparatively recent, as violently tory as any part of England. A century ago the people of this country on each successive 29th of May, pledged the "king over the water," and rotten-egged everybody that did not wear green-oak favors (it was the green-oak that furnished a shelter to the younger Charles); these customs still exist in some little frequented parts. South Lancashire,

however, appears to have been more tory than other tory parts of England. It used to be the custom for boards to be stuck up in the taverns, with the words, "No Jacobins admitted here." So late as 1825, when John Bright was fourteen years old, one of these boards remained in a public house in Manchester. In 1815, that corn law had already been introduced from which England was to experience such sufferings. This was the year of the battle of Waterloo, and the evil consequences of the act were little thought upon amid the exultations which followed victory. But bread and fuel are much more necessary things to the individual than the consciousness of belonging to a victorious nation. The suffering consequent upon the enactment of the corn law soon found vent in murmurs which, in time, swelled into insurrection and riot.

Much as we hear said about the English corn laws, it is to be doubted if many people know just what they were. England has nearly always had duties both upon the importation and exportation of corn; in former times duties were imposed upon its removal from one part of the country to another. The duty upon the exportation of corn was finally abolished in 1814. The duty upon importation has varied greatly from time to time. In 1815 (against the strong opposition of the commercial classes), the agricultural interest succeeded in fixing the high figure of 80 shillings as the limit at which there should be no duty on importation. This was the law to which the distress of England was especially due. During the course of the next ten years the voice of the poor had time to make itself heard. The distress soon became so dire and the pressure so great, that efforts were made by government in the direction of modifying the duties. In 1828, the law was changed, and a minimum of duty of one shilling was fixed when the price was 73 shillings or more, with the maximum duty of 23 shillings 8 pence when the price was 64 shillings. In 1842 the government of Sir Robert Peel enacted what was called the "Sliding Scale," fixing a minimum of duty of one shilling when the price was 73 shillings or more, and adding one shilling to the duty for each decrease of one shilling in the price until the maximum duty of 20 shillings was reached. At last, in 1846, Sir Robert Peel carried through his measure, reducing the duties at once, and fixing them at a nominal rate after an expiration of a period of three years.

This change, however, had only been effected by a popular movement of great energy, during which the anti-corn-law league was formed. In 1836 an anti-corn-law association had been formed in London, the activity of which, however, was not very great or extended. The next year, 1837, was that of the present Queen's accession. It was a year marked by great financial distress. In the elections of that year some 38 pledged Freetraders were returned to Parliament. From this time began Cobden's strenuous exertions to organize an anti-corn-law agitation. In September, 1838, some advanced Manchester Freetraders invited Sir John Bowring, who happened then to be in that town to a dinner. In the course of his speech that evening Sir John Bowring said:—"It is impossible to estimate the amount of human misery created by the corn laws, or the amount of human pleasure overthrown by them. In every part of the world I have found them the plague spot." Thereupon a Mr. Howie rose, and proposed that "the present company at once form themselves into an anti-corn-law association." This association determined that they would accept no half measures of relief, but that they would make it their business to assail any and every corn law. In 1839, the Manchester association was enlarged into a National anti-corn-law league. From this time until their final triumph the league pursued a course of determined agitation. As the movement went on, new persons from various classes of society began to join it. Thomas Carlyle said to the Conservatives, "If I were the Conservative party of England, I would not for a hundred thousand pounds an hour allow those corn laws to continue. All Potosi and Golconda put together would not purchase my assent to them." A movement seized society which swept along with it high and low. Great mass meetings were held all over England, and monster bazars and tea-fights. The women took a lively part in it. One old lady of eighty said, that "in her daily prayers for bread, she also prayed for a blessing on the good work of Richard Cobden."

Mr. Bright was, next to Cobden, the most famous leader of the League. The first meeting of these two men had taken place when Bright, then a very young man, one day walked into the warehouse of Mr. Alderman Cobden in Manchester, and asked him to address an educational meet-

ing at Rochdale. Cobden came. Bright himself made a short speech at the same meeting, and Cobden was so struck with him, that he asked him to speak as often as he could in favor of the repeal of corn laws. This was, however, before the formation of the league. Bright's name did not become known till some years after this. He married young, and his attention to business and the delights of family life, prevented him from taking a leading part. It was not until after the death of his wife, which took place in 1841, that he devoted himself to the work of securing the abolition of the corn laws. In an address which Mr. Bright delivered a few years ago, at Bradford, on the occasion of the erection of a statue of Cobden by Mr. Booth, an American citizen, he alluded as follows to the circumstances under which he first devoted himself to the task.

"At that time I was at Leamington, and I was, on the day when Mr. Cobden called upon me—for he happened to be there at the time on a visit to some relatives—I was in the depth of grief, I might almost say of despair, for the light and sunshine of my house had been extinguished. All that was left on earth of my young wife, except the memory of a sainted life, and of a too brief happiness, was lying still and cold in the chamber above us. Mr. Cobden called upon me as his friend, and addressed me, as you might suppose, with words of condolence. After a time he looked up and said, 'There are thousands of houses in England at this moment, where wives, mothers, and children are dying of hunger. Now,' he said, 'when the first paroxysm of your grief is past, I would advise you to come with me, and we will never rest till the corn law is repealed.'"

From this time on Mr. Bright was, after Cobden, the foremost leader of the movement, and by the time the repeal was accomplished, was generally admitted to be one of the first orators of the country. The speech he made in Parliament when Sir Robert Peel brought forward his free-trade measure was a great forensic success. Peel proposed that protection should cease wholly in three years, this respite being given to farmers to allow them time to accommodate themselves to the change. Bright strongly objected to the delay, but nevertheless accepted the measure as it was and spoke in behalf of it. A writer of the day says that on this occasion he appeared to be animated to an unusual pitch of oratorical excellence; that his periods, as adroit and elegant as ever, alternately glittered with satire and thrilled with the tones of pathos. With reference to Sir Robert Peel,

who had been bitterly attacked by the Conservative as a traitor and a renegade, he said:

"You say the Premier is a traitor. It would ill become me to attempt his defense after the speech he delivered last night—a speech, I will venture to say, more powerful and more to be admired than any speech which has been delivered within the memory of any man in this house. I watched him as he went home last night, and, for the first time, I envied him his feelings. That speech has circulated by scores of thousands throughout the kingdom and throughout the world; and wherever a man is to be found who loves justice, and wherever there is a laborer whom you have trampled underfoot, that speech will bring joy to the heart of the one, and hope to the breast of the other."

When these warm and feeling words were uttered, it is said that Peel could not restrain his emotion and that the tears sprang from his eyes.

It is the opinion of many that, even at this time, Mr. Bright had not attained that grace and attractiveness of speech which he had later. He drove rather than led the House of Commons; he compelled rather than persuaded. He seemed to have little respect for its time-honored conventions, and no tenderness for its vanity. The English House of Commons is said by those who know it best, to be an extremely conceited body; it resembles the man who took off his hat whenever he mentioned his own name. Mr. Disraeli's great parliamentary success has been ascribed to the skill with which he has played upon and profited by this weakness of the British Legislature. He probably has had his own opinions of the mental powers of the individuals composing that body; but it is said that he never rose in the House without seeming to be overwhelmed with the sense of his own temerity in daring to raise his voice in such a place. Later in his parliamentary career, Mr. Bright's speeches became agreeable to the House of Commons, but this was due to the natural gentleness of his spirit and to the charm and attractiveness of speech which he gained by practice. He appears to be no exception to the rule that the orator is made. A gentleman who heard him speak at a village meeting in the beginning of his career, thus describes him:

"He was dressed in black, and his coat was of that peculiar cut considered by the worthy disciples of George Fox as a standing protest against the fashions of the world. The lecturer was young, square-built, and muscular, with a broad face and forehead, with a fresh complexion, with 'mild blue eyes,' like those of the late Russian Nicholas, but, nevertheless, with a general expression quite suffi-

ciently decided and severe. As an orator, the man did not shine. His voice was good, though somewhat harsh; his manner was awkward, as is the custom of the country; and the sentences came out of his mouth loose, naked, and ill-formed. He was not master of the situation, yet he wanted not confidence, nor matter, nor words. Practice, it was clear, was all that he required. The orator felt this himself. He told his audience that he was learning to speak upon the question, and that he would succeed in time."

Mr. Gilchrist, the author of a little biography of Bright, to which we are indebted for many of our facts, says, that in 1847, the British public had as yet no just notion of Mr. Bright's powers. If this means that the public had a wrong notion of Mr. Bright, that they did not know how gentle, moderate, and wise a man he was, the opinion is, no doubt, true. It is probable, however, that the speeches made by Mr. Bright before the repeal of the corn laws were his greatest oratorical successes. He had then just the opportunity which suited his talents. His indignation, his pity for the poor, his hatred of injustice were called out to the full by the anti-corn-law movement; while in the sympathy of a great mass of people, profoundly interested in the same object with himself, he had in his favor another condition of eloquence.

In the following year, 1847, we find Mr. Bright opposing a motion, which became law in June of that year, for limiting the hours of labor for children under eighteen years of age. This action was, in part, due to Mr. Bright's general prepossessions as a free trader. When it was urged that the law was needed in the interests of education of the young of the working classes, Mr. Bright said: "For myself, I can say that I have never been at school since I was fifteen years of age." He said that in his own factory there was a large infant school, a reading-room, and a news-room, and a school for adults, where the workmen attended after office hours. There was also a person employed, at a considerable expense, who devoted his whole time to the investigation of the concerns of the working men, and who was a kind of missionary among them. He believed that the mental wants of operatives were equally well looked after in many other factories.

A large part of that unpopularity, which clung to the name of Mr. Bright until within comparatively recent years, was due to his opposition to the Crimean War. It is somewhat difficult to gather from Mr. Bright's utterances, just what his views are

upon the question of war. The Quakers are understood to be opposed to all wars. That this is not Mr. Bright's view is evident from his strenuous defense of the war for the preservation of the Union. It is certain that Mr. Bright strongly disbelieves in the utility of nearly all the wars which have been carried on by Great Britain. He even goes so far as to disapprove of that great war which gave the English name such luster and prestige in the early part of this century. But Mr. Bright does not believe much in luster and prestige. He thinks these only other names for selfishness and pride in superiority, and that these qualities are no more to be admired in nations than in individuals. He is of the opinion that a sound national prosperity, implying a widely distributed comfort and well-being, is more to be desired than the consciousness of prestige. He would no doubt say, "This national vainglory is a very acceptable luxury to people who are well housed and well fed, but to a man without a coat, or to a starving family, the reflection that 'Britannia rules the waves' must be of very little use." Mr. Bright spoke at the Peace Conference, which met in Edinburgh just previous to the outbreak of the Crimean War. It was at this Conference that Sir Charles Napier, who had declared his intention of bearding the Peace Society in its den, appeared and made a speech in favor of war. The old tar—whose person was, as usual, innocent of the labors of barber or laundress—pushed his way very unceremoniously to the platform, and took the seat immediately on the left of the chairman. His arrival considerably fluttered the sheep-fold of the philanthropists. Such visitors had been rare at the previous meetings of the Peace Society, and there was considerable curiosity as to his identity among the audience, to very few of whom he was known. He was presently introduced by Cobden, and made a strong war speech. Mr. Bright followed. In reply to Admiral Napier's remark, that the armaments of the country had been reduced to "nothing," Mr. Bright said that he would like to know what was "nothing" in the Admiral's estimation. He said that £17,000,000 had been spent during the preceding year in warlike preparations, which, added to the interest on the debt caused by war, £28,000,000, made £45,000,000. He then remarked that the exports of England during the same year—by far the largest export which had up to that time been made—amounted to £80,000,000, and then made this striking comment: that, if

some one were placed at the mouth of every port and harbor in the United Kingdom, and should take every alternate cargo that left the country and should carry it off as a tribute, it would amount to no more than was paid every year for the item of war in Great Britain.

It was, no doubt, the fact that Mr. Bright was known to be opposed to wars in general that made of so little effect his courageous opposition to the Crimean War. He, indeed, endeavored to argue the question upon grounds which would be accepted by all Englishmen. But this he was not permitted to do by the public. Kinglake says :

"Mr. Bright's orations were singularly well qualified for preventing an erroneous acquiescence in the policy of the day ; for, besides that he was honest and fearless—besides that, with a ringing voice, he had all the clearness and force which resulted from his great natural gifts, as well as from his one-sided method of thinking—he had the advantage of generally being able to speak in a state of sincere anger."

He then adds :

"A man cannot carry weight as the opponent of any particular war, if he is one who is known to be against almost all wars. * * * In vain he declares that, for the sake of argument, he will lay aside his own broad principles and mimic the reasoning of his hearers. Practical men know that his mind is under the sway of an antecedent determination, which dispenses him from the more narrow but more important inquiry in which they are engaged."

It thus happened that the opposition of Mr. Bright was perfectly helpless, and that the government could afford to treat him and Cobden with contempt. Of this, an incident which took place in the House of Commons at the beginning of the war will supply an example. Mr. Bright had alluded, with his usual angry eloquence, to the "reckless levity" which had been displayed by Lord Palmerston at a dinner which had taken place shortly before. He said that Lord Palmerston's jokes and stories at this dinner were unbecoming such a time, and were "discreditabile in the last degree to the great and responsible statesman of a civilized and Christian nation." Lord Palmerston rose and said : "Sir, if the honorable and reverend gentleman——" Here Cobden interrupted him, and called him to order, saying that the epithet was "flippant and undeserved." Lord Palmerston answered that he would not quarrel with Cobden about words, but proceeded to reply to Mr. Bright in an insulting manner. In this he knew he would

be protected by his own great popularity at that time in England, and the popularity of his policy, and by the unpopularity of Mr. Bright. He knew that he was strong enough to treat Mr. Bright as insolently as he liked.

Mr. Bright's opposition to the war cost him his seat in Parliament. His protests against it, indeed, continued nearly to its conclusion, when a severe illness compelled him to forego all participation in public affairs. He was, however, elected for Birmingham in August of 1857. Notwithstanding the unpopularity which clung to his name for some years, Mr. Bright was still heard with effect in the House of Commons and in the country. He made a number of interesting speeches upon India, which may be read with profit in connection with the course of recent events in that country. He has evidently devoted great attention to this subject. When the liberal government came into power in 1867, Mr. Bright was offered the post of Secretary of State for India, but he felt his health unequal to the labors of this position, and chose instead the Presidency of the Board of Trade.

The portion of the career of Mr. Bright which has the greatest interest for Americans is his eloquent and effectual defense of us during the trying period of the War of the Rebellion. It must not be forgotten how dark our cause often looked even to ourselves, and it is easy to conceive how much darker it must have looked to our friends in Europe. But during the whole of that long period Mr. Bright never faltered in his words of advocacy and encouragement. We cannot forget that in the very depth and crisis of our struggle he used such words as these :

"I cannot believe, for my part, that such a fate will befall that fair land, stricken though it now is with the ravages of war. I cannot believe that civilization, in its journey with the sun, will sink into endless night in order to gratify the ambition of the leaders of this revolt, who seek to 'wade through slaughter to a throne, and shut the gates of mercy on mankind.' I have another and a far brighter vision before my gaze. It may be but a vision ; but I will cherish it. I see one people, and one language, and one law, and one faith, and over all that wide continent, the home of freedom, and a refuge for the oppressed of every race and of every clime."

One cause, indeed, of the unpopularity of Mr. Bright and Cobden in England was their undisguised friendship for and

faith in this country; they were continually taunted with a desire to Americanize English institutions. Jokes at their expense on this point were very common in the press and in Parliament. Thus once in the House of Commons, when Cobden had spoken of "Rule Britannia" as the creed of the Conservatives, Mr. Disraeli replied by saying that, while the House might not be over-partial to the strains of the British pæan, it could hardly be expected to encore "Yankee Doodle." But Mr. Bright reaped in the end the reward of that sagacity and fidelity which he exhibited upon the question of our great struggle. The liberal party of England owed its long lease of power, after 1868, more to the triumph of the Union than to any other cause. Such, at least, is the opinion of many of the leaders of that party.

Mr. Bright is, before all, an orator. What his capacities are as an administrator, the world has not had much means of judging, though there can be little doubt that they are excellent. But, as an orator, he stands unquestionably among the two or three first which England has produced in this generation. His style combines energy and elegance to a high degree. In his eloquence dignity

is united to the simplicity and naturalness of conversation. His genius is expressed in his person. He has the nervous and sensitive features of the born speaker. The tones of his voice, even in conversation, attract and fascinate. A gentleman, himself a distinguished literary man, who once lunched with him, told the writer that, on this occasion, Mr. Bright repeated a stanza from Whittier with such expression that it seemed to him, as he said, "the finest thing he had ever heard." The qualities which most strike one in meeting Mr. Bright are his simplicity and gentleness. Within the past few months he has taken a more leading part in public affairs than it has been his custom to do of late years. For some time past his health has not permitted him to be very active, and we imagine that his disposition does not lead him to prefer, for its own sake, the excitement of a political career. He seems to have little ambition, and he is certainly averse to office. He has reason to be abundantly satisfied with that position in the respect and affection of his own country, and, we may add, of this, which his genius, his patriotism, his high character, and his great services have won.

A REMEMBERED TEACHER.

I SEE him now, importunate, eager, bold
 To push for truth, as most to push for gold;
 Young then, with youth's fine scorn of consequence
 He weighed no whither, so he knew his whence—
 Asked only, but asked hard, Is it a fact?
 That point well sure, deemed then he nothing lacked.
 Truth was from God, she could not lead astray.
 Fearlessly glad he walked in Truth's highway;
 Who joined him there, had fellow stout to cheer;
 Who crossed, met foe behooved his weal to fear;
 His quick, keen, urgent, sinewy, certain thrust
 Well knew those knights who felt it in the joust.

Ideal Christian teacher, master, man,
 Severely sweet, a gracious Puritan,
 Beyond my praise to-day, beyond their blame,
 He spurs me yet with his remembered name!

THE GRANDISSIMES.*

A STORY OF CREOLE LIFE.

By GEORGE W. CABLE, author of "Old Creole Days."

CHAPTER XVIII.

NEW LIGHT UPON DARK PLACES.

WHEN the long, wakeful night was over, and the doctor gone, Frowenfeld seated himself to record his usual observations of the weather; but his mind was elsewhere—here, there, yonder. There are understandings that expand, not imperceptibly hour by hour, but as certain flowers do, by little explosive ruptures, with periods of quiescence between. After this night of experiences it was natural that Frowenfeld should find the circumference of his perceptions consciously enlarged. The daylight shone, not into his shop alone, but into his heart as well. The face of Aurora, which had been the dawn to him before, was now a perfect sunrise, while in pleasant timeliness had come in this Apollo of a Honoré Grandissime. The young immigrant was dazzled. He felt a longing to rise up and run forward in this flood of beams. He was unconscious of fatigue, or nearly so—would have been wholly so but for the return by and by of that same, dim shadow, or shadows, still rising and darting across every motion of the fancy that grouped again the actors in last night's scenes; not such shadows as naturally go with sunlight to make it seem brighter, but a something which qualified the light's perfection and the air's freshness.

Wherefore, resolved: that he would compound his life, from this time forward, by a new formula: books, so much; observation, so much; social intercourse, so much; love—as to that, time enough for that in the future (if he was in love with anybody, he certainly did not know it); of love, therefore, amount not yet necessary to state, but probably (when it should be introduced), in the generous proportion in which physicians prescribe *aqua*. Resolved, in other words, without ceasing to be Frowenfeld the studious, to begin at once the perusal of this newly found book, the Community of New Orleans. True, he knew he should find it a difficult task—not only that much of it was

in a strange tongue, but that it was a volume whose displaced leaves would have to be lifted tenderly, blown free of much dust, re-arranged, some torn fragments laid together again with much painstaking, and even the purport of some pages guessed out. Obviously, the place to commence at was that brightly illuminated title-page, the ladies Nancanou.

As the sun rose and illumined an atmosphere whose temperature had just been recorded as 50° F., the apothecary stepped half out of his shop-door to face the bracing air that came blowing upon his tired forehead from the north. As he did so, he said to himself:

"How are these two Honoré Grandissimes related to each other, and why should one be thought capable of attempting the life of Agricola?"

There is left, to our eyes, but a poor vestige of the picturesque view presented to those who looked down the rue Royale before the garish day that changed the rue Enghien into Ingine street, and dropped the 'e' from Royale. It was a long, narrowing perspective of arcades, lattices, balconies, *zaguans*, dormer windows, and blue sky—of low, tiled roofs, red and wrinkled, huddled down into their own shadows; of canvas awnings with fluttering borders, and of grimy lamp-posts twenty feet in height, each reaching out a gaunt iron arm over the narrow street and dangling a lamp from its end. The human life which dotted the view displayed a variety of tints and costumes such as a painter would be glad to take just as he found them: the gayly feathered Indian, the slashed and tinseléd Mexican, the leather-breeched raftsmen, the blue or yellow turbaned *négresse*, the sugar-planter in white flannel and moccasins, the average townsman in the last suit of clothes of the lately deceased century, and now and then a fashionable man in that costume whose union of tight-buttoned martial severity, swathed throat, and effeminate superabundance of fine linen seemed to offer a sort of state's evidence against the pompous tyrannies and frivolities of the times.

The *marchande des calas* was out. She came toward Joseph's shop, singing in a high-pitched nasal tone this new song:

"Dé 'tit zozos—yé té assis—
Dé 'tit zozos—si la barrier. . .
Dé 'tit zozos, qui zabotté;
Qui ça yé di' mo pas conné.

"Manzeur-poulet vini simin,
Croupé si yé et croqué yé;
Personn' pli' 'tend' yé zabotté—
Dé 'tit zozos si la barrier."

"You lak dat song?" she asked, with a chuckle, as she let down from her turbaned head a flat Indian basket of warm rice cakes.

"What does it mean?"

She laughed again—more than the questioner could see occasion for.

"Dat mean—two lill birds; dey was sittin' on de fence an' gabblin' togeddah, you know, lak you see two young gals some-time', an' you can't mek out w'at dey say-in', even ef dey know demself? H-ya! Chicken-hawk come 'long dat road an' jes' set down an' munch 'em, an' nobody can't no mo' hea' deir lill gabblin' on de fence, you know."

Here she laughed again.

Joseph looked at her with severe suspicion, but she found refuge in benevolence.

"Honey, you ought to be asleep dis werry minit; look lak folks been a-worr'in' you. I's gwine to pick out de werry bes' *calas* I's got for you."

As she delivered them she courtesied, first to Joseph and then, lower and with hushed gravity, to a person who passed into the shop behind him, bowing and murmuring politely as he passed. She followed the new-comer with her eyes, hastily accepted the price of the cakes, whispered, "Dat's my mawstah," lifted her basket to her head and went away. Her master was Frowenfeld's landlord.

Frowenfeld entered after him, *calas* in hand, and with a grave "good morning, sir."

"— m'sieu'," responded the landlord, with a low bow.

Frowenfeld waited in silence.

The landlord hesitated, looked around him, seemed about to speak, smiled, and said, in his soft, solemn voice, feeling his way word by word through the unfamiliar language:

"Ah lag to teg you apar'."

"See me alone?"

The landlord recognized his error by a fleeting smile.

"Alone," said he.

"Shall we go into my room?"

"*S'il vous plait, m'sieu'.*"

Frowenfeld's breakfast, furnished by contract from a neighboring kitchen, stood on the table. It was a frugal one, but more comfortable than formerly, and included coffee, that subject of just pride in Creole cookery. Joseph deposited his *calas* with these things and made haste to produce a chair, which his visitor, as usual, declined.

"Idd you' bregfuz, m'sieu'."

"I can do that afterward," said Frowenfeld; but the landlord insisted and turned away from him to look up at the books on the wall, precisely as that other of the same name had done a few weeks before.

Frowenfeld, as he broke his loaf, noticed this, and, as the landlord turned his face to speak, wondered that he had not before seen the common likeness.

"Dez stog," said the somber man.

"What, sir? Oh!—dead stock? But how can the materials of an education be dead stock?"

The landlord shrugged. He would not argue the point. One American trait which the Creole is never entirely ready to encounter is this gratuitous Yankee way of going straight to the root of things.

"Dead stock in a mercantile sense, you mean," continued the apothecary; "but are men right in measuring such things only by their present market value?"

The landlord had no reply. It was little to him, his manner intimated; his contemplation dwelt on deeper flaws in human right and wrong; yet—but it was needless to discuss it. However, he did speak.

"Ah was elevade in Pariz."

"Educated in Paris," exclaimed Joseph, admiringly. "Then you certainly cannot find *your* education dead stock."

The grave, not amused, smile which was the landlord's only reply, though perfectly courteous, intimated that his tenant was sailing over depths of the question that he was little aware of. But the smile in a moment gave way for the look of one who was engrossed with another subject.

"M'sieu'," he began; but just then Joseph made an apologetic gesture and went forward to wait upon an inquirer after "Godfrey's Cordial"; for that comforter was known to be obtainable at "Frowenfeld's." The business of the American drug-store

was daily increasing. When Frowenfeld returned his landlord stood ready to address him, with the air of having decided to make short of a matter.

"M'sieu'——"

"Have a seat, sir," urged the apothecary.

His visitor again declined, with his uniform melancholy grace. He drew close to Frowenfeld.

"Ah wand you mague me one *ouangan*," he said.

Joseph shook his head. He remembered Doctor Keene's expressed suspicion concerning the assault of the night before.

"I do not understand you, sir; what is that?"

"You know."

The landlord offering a heavy, persuading smile.

"An unguent? Is that what you mean—an ointment?"

"M'sieu'," said the applicant, with a note-to-be-deceived expression, "*vous etes astrologe—magicien——*"

"God forbid!"

The landlord was grossly incredulous.

"You godd one 'P'tit Albert,'"

He dropped his forefinger, upon an iron-clasped book on the table, whose title much use had effaced.

"That is the Bible. I do not know what the Tee Albare is!"

Frowenfeld darted an aroused glance into the ever-courteous eyes of his visitor, who said without a motion:

"You di'n't gave Agricola Fusilier *une ouangan, la nuit passe?*"

"Sir?"

"Ee was yeh?—laz nighd?"

"Mr. Fusilier was here last night—yes. He had been attacked by an assassin and slightly wounded. He was accompanied by his nephew, who, I suppose, is your cousin; he has the same name."

Frowenfeld, hoping he had changed the subject, concluded with a propitiatory smile, which, however, was not reflected.

"Ma bruzzah," said the visitor.

"Your brother!"

"Ma whide bruzzah; ah ham nod whide, m'sieu'."

Joseph said nothing. He was too much averted to speak; the ejaculation that started toward his lips turned back and rushed into his heart, and it was the quadroon who, after a moment, broke the silence:

"Ah ham de holdez son of Numa Grandissime."

"Yes—yes," said Frowenfeld, as if he would wave away something terrible.

"Nod sell me—*ouangan?*" asked the landlord, again.

"Sir," exclaimed Frowenfeld, taking a step backward, "pardon me if I offend you; that mixture of blood which draws upon you the scorn of this community, is to me nothing—nothing! And every invidious distinction made against you on that account I despise! But, sir, whatever may be either your private wrongs, or the wrongs you suffer in common with your class, if you have it in your mind to employ any manner of secret art against the interests or person of any one——"

The landlord was making silent protestations, and his tenant, lost in a wilderness of indignant emotions, stopped.

"M'sieu'," began the quadroon, but ceased and stood with an expression of annoyance every moment deepening on his face, until he finally shook his head slowly, and said with a baffled smile: "Ah can nod spig English."

"Write it," said Frowenfeld, lifting forward a chair.

The landlord, for the first time in their acquaintance, accepted a seat, bowing low as he did so, with a demonstration of profound gratitude that just perceptibly heightened his even dignity. Paper, quills, and ink were handed down from a shelf and Joseph retired into the shop.

Honoré Grandissime, f. m. c. (these initials could hardly have come into use until some months later, but the convenience covers the sin of the slight anachronism), Honoré Grandissime, free man of color, entered from the rear room so silently that Joseph was first made aware of his presence by feeling him at his elbow. He handed the apothecary—but a few words in time, lest we misjudge.

The father of the two Honorés was that Numa Grandissime—that mere child—whom the Grand Marquis, to the great chagrin of the De Grapions, had so early cadetted. The commission seems not to have been thrown away. While the province was still in first hands, Numa's was a shining name in the annals of Kerlerec's unsatisfactory Indian wars; and in the revolution of 1768 (when the colonists, ill-informed, inflammable, and long ill-governed, resisted the transfer of Louisiana to Spain), at a time of life when most young men absorb all the political extravagances of their

day, he had stood by the side of law and government, though the popular cry was a frenzied one for "liberty." Moreover, he had held back his whole chafing and stamping tribe from a precipice of disaster, and had secured valuable recognition of their office-holding capacities from that really good governor and princely Irishman whose one act of summary vengeance upon a few insurgent office-coveters has branded him in history as Cruel O'Reilly. But the experience of those days turned Numa gray, and withal he was not satisfied with their outcome. In the midst of the struggle he had weakened in one manly resolve—against his will he married. The lady was a Fusilier, Agricola's sister, a person of rare intelligence and beauty, whom, from early childhood, the secret counsels of his seniors had assigned to him. Despite this, he had said he would never marry; he made, he said, no pretensions to severe conscientiousness, or to being better than others, but—as between his Maker and himself—he had forfeited the right to wed, they all knew how. But the Fusiliers had become very angry and Numa, finding strife about to ensue just when without unity he could not bring an undivided clan through the torrent of the revolution, had "nobly sacrificed a little sentimental feeling," as his family defined it, by breaking faith with the mother of the man now standing at Joseph Frowenfeld's elbow, and who was then a little toddling boy. It was necessary to save the party—nay, that was a slip; we should say, to save the family; this is not a parable. Yet Numa loved his wife. She bore him a boy and a girl, twins; and as, her son grew in physical, intellectual, and moral symmetry, he indulged the hope that—the ambition and pride of all the various Grandissimes now centering in this lawful son, and all strife being lulled, he should yet see this Honoré right the wrongs which he had not quite dared to uproot. And Honoré inherited the hope and began to make it an intention and aim even before his departure (with his half-brother the other Honoré) for school in Paris, at the early age of fifteen. Numa soon after died, and Honoré, after various fortunes in Paris, London, and elsewhere, in the care, or at least company, of a pious uncle in holy orders, returned to the ancestral mansion. The father's will left the darker Honoré the bulk of his fortune, the younger a competency. The latter—instead of taking office as an ancient Grandissime should have done—to the dis-

may and mortification of his kindred, established himself in a prosperous commercial business. The elder bought houses and became a *rentier*.

The landlord handed the apothecary the following writing:

MR. JOSEPH FROWENFELD:

Think not that anybody is to be either poisoned by me nor yet to be made a sufferer by the exercise of anything by me of the character of what is generally known as *grigi*, otherwise *magique*. This, sir, I do beg your permission to offer my assurance to you of the same. Ah, no! it is not for that! I am the victim of another entirely and a far different and dissimilar passion, *i. e.*, Love. Esteemed sir, speaking or writing to you as unto the only man of exclusively white blood whom I believe is in Louisiana willing to do my dumb, suffering race the real justice, I love Palmyre la Philosophe with a madness which is by the human lips or tongues not possible to be exclaimed (as, I may add, that I have in the same like manner since exactly nine years and seven months and some days). Alas! heavens! I can't help it in the least particles at all! What what shall I do, for ah! it is pitiful! She loves me not at all, but, on the other hand, is (if I suspicion not wrongfully) wrapped up head and ears in devotion of one who does not love her, either, so cold and incapable of appreciation is he. I allude to Honoré Grandissime.

Ah! well do I remember the day when we returned—he and me—from the France. She was there when we landed on that levee, she was among that throng of kindreds and domestiques, she shined like the evening star as she stood there (it was the first time I saw her, but she was known to him when at fifteen he left his home, but I resided not under my own white father's roof—not at all—far from that). She cried out '*A la fin to vini!*' and leap herself with both resplendent arm around his neck and kiss him twice on the one cheek and the other, and her resplendent eyes shining with a so great beauty.

If you will give me a *poudre d'amour* such as I doubt not your great knowledge enable you to make of a power that cannot to be resist, while still at the same time of a harmless character toward the life or the health and of such that I shall succeed in its use to gain the affections of that emperice of my soul, I hesitate not to give you such price as it may please you to nominate up as high as to \$1,000—nay, more. Sir, will you do that?

I have the honor to remain, sir,

Very respectfully, your obedient servant,
H. GRANDISSIME.

Frowenfeld slowly transferred his gaze from the paper to his landlord's face. Dejection and hope struggled with each other in the gaze that was returned; but when Joseph said, with a countenance full of pity, "I have no power to help you," the disappointed lover merely gazed fixedly for a moment toward the street, then lifted his hat toward his head, bowed, and departed.

CHAPTER XIX.

ART AND COMMERCE.

It was some two or three days after the interview just related that the apothecary of the rue Royale found it necessary to ask a friend to sit in the shop a few minutes while he should go on a short errand. He was kept away somewhat longer than he had intended to stay, for, as they were coming out of the cathedral, he met Aurora and Clotilde. Both the ladies greeted him with a cordiality which was almost inebriating, Aurora even extending her hand. He stood but a moment, responding blushing to two or three trivial questions from Aurora; yet even in so short a time, and although Clotilde gave ear with the sweetest smiles and loveliest changes of countenance, he experienced a lively renewal of a conviction that this young lady was most unjustly harboring toward him a vague disrelish, if not a positive distrust. That she had some mental reservation was certain.

"Sieur Frowenfel," said Aurora, as he raised his hat for good-day, "you din come home yet."

He did not understand until he had crimsoned and answered he knew not what—something about having intended every day. He felt lifted he knew not where, Paradise opened, there was a flood of glory, and then he was alone; the ladies, leaving adieux sweeter than the perfume they carried away with them, floated into the south and were gone. Why was it that the elder, though plainly regarded by the younger with admiration, dependence, and overflowing affection, seemed sometimes to be, one might almost say, watched by her? He liked Aurora the better.

On his return to the shop his friend remarked that if he received many such visitors as the one who had called during his absence, he might be permitted to be vain. It was Honoré Grandissime, and he had left no message.

"Frowenfeld," said his friend, "it would pay you to employ a regular assistant."

Joseph was in an abstracted mood.

"I have some thought of doing so."

Unlucky slip! As he pushed open his door next morning, what was his dismay to find himself confronted by some forty men. Five of them leaped up from the door-sill, and some thirty-five from the edge of the *trottoir*, brushed that part of their wearing apparel which always fits with great neat-

ness on a Creole, and trooped into the shop. The apothecary fell behind his defenses, that is to say, his prescription desk, and explained to them in a short and spirited address that he did not wish to employ any of them on any terms. Nine-tenths of them understood not a word of English; but his gesture was unmistakable. They bowed gratefully, and said good-day.

Now Frowenfeld did these young men an injustice; and though they were far from letting him know it, some of them felt it and interchanged expressions of feeling reproachful to him as they stopped on the next corner to watch a man painting a sign. He had treated them as if they all wanted situations. Was this so? Far from it. Only twenty were applicants; the other twenty were friends who had come to see them get the place. And again, though, as the apothecary had said, none of them knew anything about the drug business—no, nor about any other business under the heavens—they were all willing that he should teach them—except one. A young man of patrician softness and costly apparel tarried a moment after the general exodus, and quickly concluded that on Frowenfeld's account it was probably as well that he could not qualify, since he was expecting an important government appointment as soon as these troubles should be settled and Louisiana restored to her former happy condition. But he had a friend—a cousin—whom he would recommend, just the man for the position; a splendid fellow; popular, accomplished—what? the best trainer of dogs that M. Frowenfeld might ever hope to look upon; a "so good fisherman as I never saw!"—the marvel of the ball-room—could handle a partner of twice his weight; the speaker had seen him take a lady so tall that his head hardly came up to her bosom, whirl her in the waltz from right to left—this way! and then, as quick as lightning, turn and whirl her this way, from left to right—"so grezful ligue a peajohn! He could read and write, and knew more comig song!"—the speaker would hasten to secure him before he should take some other situation.

The wonderful waltzer never appeared upon the scene; yet Joseph made shift to get along, and by and by found a man who partially met his requirements. The way of it was this: With his forefinger in a book which he had been reading, he was one day pacing his shop floor in deep thought. There were two loose threads

hanging from the web of incident weaving around him which ought to connect somewhere; but where? They were the two visits made to his shop by the young merchant, Honoré Grandissime. He stopped still to think; what "train of thought" could he have started in the mind of such a man?

He was about to resume his walk, when there came in, or, more strictly speaking, there shot in, a young, auburn-curled, blue-eyed man, whose adolescent buoyancy, as much as his delicate, silver-buckled feet and clothes of perfect fit, pronounced him all-pure-Creole. His name, when it was presently heard, accounted for the blonde type by revealing a Franco-Celtic origin.

"Sieur Frowenfel'," he said, advancing like a boy coming in after recess, "I 'ave someting' beauteeful to place into yo' window."

He wheeled half around as he spoke and seized from a naked black boy, who at that instant entered, a rectangular object enveloped in paper.

Frowenfeld's window was fast growing to be a place of art exposition. A pair of statuettes, a golden tobacco-box, a costly jewel-casket, or a pair of richly gemmed horse-pistols—the property of some ancient gentleman or dame of emaciated fortune, and which must be sold to keep up the bravery of good clothes and pomade that hid slow starvation, went into the shop-window of the ever-obliging apothecary, to be disposed of by *tombola*. And it is worthy of note in passing, concerning the moral education of one who proposed to make no conscious compromise with any sort of evil, that in this drivelling species of gambling he saw nothing hurtful or improper. But "in Frowenfeld's window" appeared also articles for simple sale or mere transient exhibition; as, for instance, the wonderful tapestries of a blind widow of ninety; tremulous little bunches of flowers, proudly stated to have been made entirely of the bones of the ordinary catfish; others, large and spreading, the sight of which would make any botanist fall down "and die as mad as the wild waves be," whose ticketed merit was that they were composed exclusively of materials produced upon Creole soil; a picture of the Ursulines' convent and chapel, done in forty-five minutes by a child of ten years, the daughter of the widow Felicie Grandissime; and the siege of Troy, in ordinary ink, done entirely with the pen, the labor of twenty years, by "a citizen of

New Orleans." It was natural that these things should come to "Frowenfeld's corner," for there, oftener than elsewhere, the critics were gathered together. Ah! wonderful men, those critics; and, fortunately, we have a few still left.

The young man with auburn curls rested the edge of his burden upon the counter, tore away its wrappings and disclosed a painting.

He said nothing—with his mouth; but stood at arm's length balancing the painting and casting now upon it and now upon Joseph Frowenfeld a look more replete with triumph than Cæsar's three-worded dispatch.

The apothecary fixed upon it long and silently the gaze of a somnambulist. At length he spoke:

"What is it?"

"Louisiana rif-using to hanter de h Union!" replied the Creole, with an ecstasy that threatened to burst forth in hip-hurrahs.

Joseph said nothing, but silently wondered at Louisiana's anatomy.

"Gran' subjek'!" said the Creole.

"Allegorical," replied the hard-pressed apothecary.

"Allegoricon? No, sir! Allegoricon never saw that pigshoe. If you insist to know who make dat pigshoe—de hartis' stan' bif-ore you!"

"It is your work?"

"'Tis de work of me, Raoul Innerarity, cousin to de distingwish Honoré Grandissime. I swear to you, sir, on a stack of Bible' as 'igh as yo' head!"

He smote his breast.

"Do you wish to put it in the window?"

"Yes, seh."

"For sale?"

M. Raoul Innerarity hesitated a moment before replying:

"Sieur Frowenfel', I think it is a foolishness to be too proud, eh? I want you to say, 'My frien', 'Sieur Innerarity, never care to sell anything; 'tis for eggs-hibbyshun'; *mais*—when somebody look at it, so," the artist cast upon his work a look of languishing covetousness, "'you say, *foudre tonnere!* what de dev'!—I take dat ris-pon-sible-ty—you can have her for two hun' red fifty dollah!' Better not be too proud, eh, 'Sieur Frowenfel'?"

"No, sir," said Joseph, proceeding to place it in the window, his new friend following him about, spaniel-wise; "but you

had better let me say plainly that it is for sale."

"Oh—I don't care—*mais*—my rillation' will never forgive me! *Mais*—go-ahead-I-don't-care! 'Tis for sale."

"'Sieur Frowenfel," he resumed, as they came away from the window, "one week ago"—he held up one finger—"what I was doing? Makin' bill of ladin', my faith!—for my cousin Honoré! an' now, I ham a hartis'! So soon I foun' dat, I say, 'Cousin Honoré,'"—the eloquent speaker lifted his foot and administered to the empty air a soft, polite kick—"I never goin' to do anoder lick o' work so long I live; adieu!"

He lifted a kiss from his lips and wafted it in the direction of his cousin's office.

"Mr. Innerarity," exclaimed the apothecary, "I fear you are making a great mistake."

"You tink I hass too much?"

"Well, sir, to be candid, I do; but that is not your greatest mistake."

"What she's worse?"

The apothecary simultaneously smiled and blushed.

"I would rather not say; it is a passably good example of Creole art; there is but one way by which it can ever be worth what you ask for it."

"What dat is?"

The smile faded and the blush deepened as Frowenfeld replied:

"If it could become the means of reminding this community that crude ability counts next to nothing in art, and that nothing else in this world ought to work so hard as genius, it would be worth thousands of dollars!"

"You tink she is worse a t'ousand dollah?" asked the Creole, shadow and sunshine chasing each other across his face.

"No, sir."

The unwilling critic strove unnecessarily against his smile.

"'Ow much you t'ink?"

"Mr. Innerarity, as an exercise it is worth whatever truth or skill it has taught you; to a judge of paintings it is ten dollars worth of paint thrown away; but as an article of sale it is worth what it will bring without misrepresentation."

"Two—hun-rade an'—fifty—dollahs or—not'in'!" said the indignant Creole, clenching one fist, and with the other hand lifting his hat by the front corner and slapping it down upon the counter. "Ha, ha, ha! a pase of waint—a wase of paint!

'Sieur Frowenfel', you don' know not'in' 'bout it! You har a jedge of painting?" he added cautiously.

"No, sir."

"*Eh, bien! foudre tonnere!*—look yeh! you know? 'Sieur Frowenfel'? Dat de way de publique halways talk about a hartis's fir's pigshoe. But, I hass you to pardon me, Monsieur Frowenfel', if I 'ave speak a lill too warm."

"Then you must forgive me if, in my desire to set you right, I have spoken with too much liberty. I probably should have said only what I first intended to say, that unless you are a person of independent means——"

"You t'ink I would make bill of ladin'? Ah! Hm-m!"

"——that you had made a mistake in throwing up your means of support——"

"But 'e 'as fill de place an' don' want me no mo'. You want a clerk?—one what can speak fo' lang-widge—French, Eng-lish, Spanish, an' Italianne? Come! I work for you in de mawnin' an' paint in de evenin'; come!"

Joseph was taken unaware. He smiled, frowned, passed his hand across his brow, noticed, for the first time since his delivery of the painting, the naked little boy standing against the edge of a door, said, "Why——," and smiled again.

"I riffer you to my cousin, Honoré," said Innerarity.

"Have you any knowledge of this business?"

"I 'ave."

"Can you keep shop in the forenoon or afternoon indifferently, as I may require?"

"Eh? Forenoon—afternoon?" was the reply.

"Can you paint sometimes in the morning and keep shop in the evening?"

"Yes, seh."

Minor details were arranged on the spot. Raoul dismissed the black boy, took off his coat and fell to work decanting something, with the understanding that his salary, a microscopic one, should begin from date if his cousin should recommend him.

"'Sieur Frowenfel'," he called from under the counter, later in the day, "you t'ink it would be hanny disgrace to paint de pigshoe of a niggah?"

"Certainly not."

"Ah, my soul! what a pigshoe I could paint of Bras-Coupé!"

We have the afflatus in Louisiana, if nothing else.

CHAPTER XX.

A VERY NATURAL MISTAKE.

MR. RAOUL INNERARITY proved a treasure. The fact became patent in a few hours. To a student of the community he was a key, a lamp, a lexicon, a microscope, a tabulated statement, a book of heraldry, a city directory, a glass of wine, a Book of Days, a pair of wings, a comic almanac, a diving-bell, a Creole *veritas*. Before the day had had time to cool, his continual stream of words had done more to elucidate the mysteries in which his employer had begun to be befogged than half a year of the apothecary's slow and scrupulous guessing. It was like showing how to carve a strange fowl. The way he dove-tailed story into story and drew forward in panoramic procession Lufki-Humma and Épaminondas Fusilier, Zephyr Grandissime and the Lady of the *lettre de cachet*, Demosthenes De Grapion and the *fille à l'hospital*, George De Grapion and the *fille à la casséte*, Numa Grandissime, father of the two Honorés, young Nancanou and old Agricola,—the way he made them

“Knit hands and beat the ground
In a light, fantastic round,”

would have shamed the skilled volubility of Sheherazade.

“Look!” said the story-teller, summing up; “you take hanny 'istory of France an' see de hage of my familie. Pipple talk about de Boulignys, de Sauvés, de Grand-prés, de Lemoynes, de St. Maxents, *pou'e* —bla-a-a! De Grandissimes is as hole as de dev'! What? De mose of de Creole families is not so hold as plenty of my yallah kinfolks!”

The apothecary found very soon that a little salt improved M. Raoul's statements.

But here he was, a perfect treasure, and Frowenfeld, fleeing before his illimitable talking power in order to digest in seclusion the ancestral episodes of the Grandissimes and De Grapions, laid pleasant plans for the immediate future. To-morrow morning he would leave the shop in Raoul's care and call on M. Honoré Grandissime to advise with him concerning the retention of the born artist as a drug-clerk. To-morrow evening he would pluck up all his courage and force his large but bashful feet up to the door-step of Number 19 rue Bienville. And the next evening he would go and see what might be the matter with

Doctor Keene, who had looked ill on last parting with the evening group that lounged in Frowenfeld's door, some three days before. The intermediate hours were to be devoted, of course, to the prescription desk and his “dead stock.”

And yet after this order of movement had been thus compactly planned, there all the more seemed still to be that abroad which, now on this side, and now on that, was urging him in a nervous whisper to make haste. There had escaped into the air, it seemed, and was gliding about, the expectation of a crisis.

Such a feeling would have been natural enough to the tenants of Number 19 rue Bienville, now spending the tenth of the eighteen days of grace allowed them in which to save their little fortress. For Palmyre's assurance that the candle-burning would certainly cause the rent-money to be forthcoming in time was to Clotilde unknown, and to Aurora it was poor stuff to make peace of mind of. But there was a degree of impracticability in these ladies, which, if it was unfortunate, was, nevertheless, a part of their Creole beauty, and made the absence of any really brilliant outlook what the galaxy makes a moonless sky. Perhaps they had not been as diligent as they might have been in canvassing all possible ways and means for meeting the pecuniary emergency so fast bearing down upon them. From a Creole standpoint, they were not bad managers. They could dress delightfully on an incredibly small outlay; could wear a well-to-do smile over an inward sigh of stifled hunger; could tell the parents of their one or two scholars to consult their convenience, and then come home to a table that would make any kind soul weep; but as to estimating the velocity of bills payable in their orbits, such trained sagacity was not theirs. Their economy knew how to avoid what the Creole-African apothegm calls *commerce Man Lizon—qui asseté pou' trois picailons et vend' pou'e in escalin* (bought for three picayunes and sold for two); but it was an economy that made their very hound a Spartan; for, had that economy been half as wise as it was heroic, his one meal a day would not always have been the cook's leavings of cold rice and the lickings of the gumbo plates.

On the morning fixed by Joseph Frowenfeld for calling on M. Grandissime, on the banquette of the rue Toulouse, directly in front of an old Spanish archway and opposite a blacksmith's shop,—this black-

smith's shop stood between a jeweler's store and a large, balconied and dormer-windowed wine-warehouse,—Aurore Nancanou, closely veiled, had halted in a hesitating way and was inquiring of a gigantic negro cartman the whereabouts of the counting-room of M. Honoré Grandissime.

Before he could respond she descried the name upon a staircase within the archway, and, thanking the cartman as she would have thanked a prince, hastened to ascend. An inspiring smell of warm rusks, coming from a bakery in the paved court below, rushed through the archway and up the stair and accompanied her into the cemetery-like silence of the counting-room. There were in the department some fourteen clerks. It was a den of Grandissimes. More than half of them were men beyond middle life, and some were yet older. One or two are so handsome, under their noble silvery locks, that almost any woman—Clotilde, for instance,—would have thought, "No doubt that one, or that one, is the head of the house." Aurora approached the railing which shut in the silent toilers and directed her eyes to the farthest corner of the room. There sat there at a large desk a thin, sickly-looking man with very sore eyes and two pairs of spectacles, plying a quill with a privileged loudness.

"H-h-m-m!" said she, very softly.

A young man laid down his rule and stepped to the rail with a silent bow. His face showed a jaded look. Night revelry, rather than care or years, had wrinkled it; but his bow was high-bred.

"Madame,"—in an undertone.

"Monsieur, it is M. Grandissime whom I wish to see," she said, in French.

But the young man responded in English.

"You har one tennant, ent it?"

"Yes, seh."

"Zen eet ees M. De Brahmin zat you 'ave too see."

"No, seh; M. Grandissime."

"M. Grandissime nevva see one tennant."

"I muz see M. Grandissime."

Aurora lifted her veil and laid it up on her bonnet.

The clerk immediately crossed the floor to the distant desk. The quill of the sore-eyed man scratched louder—scratch, scratch—as though it were trying to scratch under the door of Number 19 rue Bienville—for a moment, and then ceased. The clerk, with one hand behind him and one touching the desk, murmured a few words, to which the

other, after glancing under his arm at Aurora, gave a short, low reply and resumed his pen. The clerk returned, came through a gate-way in the railing, led the way into a rich inner room, and turning with another courtly bow, handed her a cushioned arm-chair and retired.

"After eighteen years," thought Aurora, as she found herself alone. It had been eighteen years since any representative of the De Grapion line had met a Grandissime face to face, so far as she knew; even that representative was only her deceased husband, a mere connection by marriage. How many years it was since her grandfather, Georges De Grapion, captain of dragoons, had had his fatal meeting with a Mandarin de Grandissime, she did not remember. There, opposite her on the wall, was the portrait of a young man in a corset who might have been M. Mandarin himself. She felt the blood of her race growing warmer in her veins. "Insolent tribe," she said, without speaking, "we have no more men left to fight you; but now wait. See what a woman can do."

These thoughts ran through her mind as her eye passed from one object to another. Something reminded her of Frowenfeld, and, with mingled defiance at her inherited enemies and amusement at the apothecary, she indulged a quiet smile. The smile was still there as her glance in its gradual sweep reached a small mirror.

She almost leaped from her seat.

Not because that mirror revealed a recess which she had not previously noticed; not because behind a costly desk therein sat a youngish man, reading a letter; not because he might have been observing her, for it was altogether likely that, to avoid premature interruption, he had avoided looking up; nor because this was evidently Honoré Grandissime; but because Honoré Grandissime, if this were he, was the same person whom she had seen only with his back turned in the pharmacy—the rider whose horse ten days ago had knocked her down, the Lieutenant of Dragoons who had unmasked and to whom she had unmasked at the ball! Fly! But where? How? It was too late; she had not even time to lower her veil. M. Grandissime looked up at the glass, dropped the letter with a slight start of consternation and advanced quickly toward her. For an instant her embarrassment showed itself in a mantling blush and a distressful yearning to escape; but the next moment she rose, all a-flutter

within, it is true, but with a face as nearly sedate as the inborn witchery of her eyes would allow.

He spoke in Parisian French:

"Please be seated, madame."

She sank down.

"Do you wish to see me?"

"No, sir."

She did not see her way out of this falsehood, but—she couldn't say yes.

Silence followed.

"Whom do——"

"I wish to see M. Honoré Grandissime."

"That is my name, madame."

"Ah!"—with an angelic smile; she had collected her wits now, and was ready for war. "You are not one of his clerks?"

M. Grandissime smiled softly, while he said to himself: "You little honey-bee, you want to sting me, eh?" and then he answered her question.

"No, madame; I am the gentleman you are looking for."

"The gentleman she was look—" her pride resented the fact. "Me!"—thought she—"I have not a doubt I am the lady whom you have been longing to meet ever since the ball"; but her look was unmoved gravity. She touched her handkerchief to her lips and handed him the rent notice.

"I received that from your office the Monday before last."

There was a slight emphasis in the announcement of the time; it was the day of the run over.

Honoré Grandissime, stopping with the rent-notice only half unfolded, saw the advisability of calling up all the resources of his sagacity and wit in order to answer wisely; and as they answered his call a brighter nobility so overspread face and person that Aurora inwardly exclaimed at it even while she exulted in her thrust.

"Monday before last?"

She slightly bowed.

"A serious misfortune befell me that day," said M. Grandissime.

"Ah?" replied the lady, raising her brows with polite distress, "but you have entirely recovered, I suppose."

"It was I, madame, who that evening caused you a mortification for which I fear you will accept no apology."

"On the contrary," said Aurora, with an air of generous protestation, "it is I who should apologize; I fear that I injured your horse."

M. Grandissime only smiled, and open-

ing the rent-notice dropped his glance upon it while he said in a preoccupied tone:

"My horse is very well, I thank you."

But as he read the paper, his face assumed a serious air and he seemed to take an unnecessary length of time to reach the bottom of it.

"He is trying to think how he will get rid of me," thought Aurora; "he is making up some pretext with which to dismiss me, and when the tenth of March comes we shall be put into the street."

M. Grandissime extended the letter toward her, but she did not lift her hands.

"I beg to assure you, madame, I could never have permitted this notice to reach you from my office; I am not the Honoré Grandissime for whom this is signed."

Aurora smiled in a way to signify clearly that that was just the subterfuge she had been anticipating. Had she been at home she would have thrown herself, face downward, upon the bed; but she only smiled meditatively upward at the picture of an East Indian harbor and made an unnecessary re-arrangement of her handkerchief under her folded hands.

"There are, you know,"—began Honoré, with a smile which changed the meaning to "you know very well there are"—"two Honoré Grandissimes. This one who sent you this letter is a man of color——"

"Oh!" exclaimed Aurora, with a sudden malicious sparkle.

"If you will entrust this paper to me," said Honoré, quietly, "I will see him, and do now engage that you shall have no further trouble about it. Of course, I do not mean that I will pay it, myself; I dare not offer to take such a liberty."

Then he felt that a warm impulse had carried him a step too far.

Aurora rose up with a refusal as firm as it was silent. She neither smiled nor scintillated now, but wore an expression of amiable practicality as she presently said, receiving back the rent-notice as she spoke:

"I thank you, sir, but it might seem strange to him to find his notice in the hands of a person who can claim no interest in the matter. I shall have to attend to it myself."

"Ah! little enchantress," thought her grave-faced listener, as he gave attention, "this, after all—ball and all—is the mood in which you look your very, very best"—a fact which nobody knew better than the enchantress herself.

He walked beside her toward the open door leading back into the counting-room,

and the dozen and more clerks, who, each by some ingenuity of his own, managed to secure a glimpse of them, could not fail to feel that they had never before seen quite so fair a couple. But she dropped her veil, bowed M. Grandissime a polite "No farther," and passed out.

M. Grandissime walked once up and down his private office, gave the door a soft push with his foot and lighted a cigar.

The clerk who had before acted as usher came in and handed him a slip of paper with a name written on it. M. Grandissime folded it twice, gazed out the window, and finally nodded. The clerk disappeared, and Joseph Frowenfeld paused an instant in the door and then advanced, with a buoyant good-morning.

"Good-morning," responded M. Grandissime.

He smiled and extended his hand, yet there was a mechanical and preoccupied air that was not what Joseph felt justified in expecting.

"How can I serve you, Mr. Frowenfeld?" asked the merchant, glancing through into the counting-room. His coldness was almost all in Joseph's imagination, but to

the apothecary it seemed such that he was almost induced to walk away without answering. However, he replied:

"A young man whom I have employed refers to you to recommend him."

"Yes, sir? Prhay, who is that?"

"Your cousin, I believe, Mr. Raoul Innerarity."

M. Grandissime gave a low, short laugh, and took two steps toward his desk.

"Rhaoul? Oh yes, I rrecommend Rhoaul to you. As an assistant in yo' sto'? —the best man you could find."

"Thank you, sir," said Joseph, coldly.

"Good-morning!" he added, turning to go.

"Mr. Frhowenfeld," said the other, "do you evva rhide?"

"I used to ride," replied the apothecary, turning, hat in hand, and wondering what such a question could mean.

"If I send a saddle-hoss to yo' do' on day aftah to-morrhow evening at fo' o'clock, will you rhide out with me for-h about a hour-h and a half—just for-h a little pleasu'e?"

Joseph was yet more astonished than before. He hesitated, accepted the invitation, and once more said good-morning.

(To be continued.)

PORTO FINO.

I KNOW a girl—she is a poet's daughter,
 And many-mooded like a poet's day,
 And changing as the Mediterranean water;
 We walked together by an emerald bay,

So deep, so green, so promontory-hidden
 That the lost mariner might peer in vain
 Through storms, to find where he erewhile had ridden
 Safe-sheltered from the wild and windy main.

Down the high stairs we clambered just to rest a
 Cool moment in the church's antique shade.
 How gay the aisles and altars! 'Twas the festa
 Of brave Saint George who the old dragon laid.

How bright the little port! The red flags fluttered,
 Loud clanged the bells, and loud the children's glee:
 What though some distant, unseen storm-cloud muttered,
 And waves breathed big along the weedy quay.

We climbed the hill whose rising cleaves asunder
 Green bay and blue immeasurable sea;
 We heard the breakers at its bases thunder;
 We heard the chanting priests' harsh minstrelsy.

Then through the graveyard's straight and narrow portal
 Our journey led. How dark the place! How strange
 Its steep, black mountain walls,—as if the immortal
 Spirit could thus be stayed its skyward range!

Beyond, the smoky olives clothed the mountains
 In green that grew in many a moonlight night.
 Below, through cleft and chasm leaped snowy fountains,
 Above, the sky was warm, and blue, and bright.

When, sudden, from out a fair and smiling heaven
 Burst forth the rain, quick as a trumpet-blare:
 Yet still the Italian sun each drop did leaven
 And turned the rain to diamonds in the air.

A VALENTINE.

BEWARE of one who loves thee but too well!
 Of one who fain would bind thee with a spell,
 With power to draw thee, as an unknown land
 Lures the impassioned traveler to its strand.

Oh! if thou wouldst be free,
 Beware of me!

Beware of eyes that softly fix on thee,
 Tamed in their restless glances by thine own,
 And of a voice, where all things that may be
 In maiden hearts are told in every tone.

If thou wouldst still be free,
 Beware of me!

But if a longing, born within thy soul
 Gives thee a far off glimpse of unknown bliss,
 Then let thy love speed onward to its goal,
 Nor thy true rest and joy for blindness miss.

If thou wouldst not be free,
 Then come to me!

A KNIGHT OF DANNEBROG.

I.

VICTOR JULIEN ST. DENIS DANNEVIG is a very aristocratic conglomeration of sound, as every one will admit, although the St. had a touch of irony in it unless placed before the Julien, where in the present case its suggestion was not wholly unappropriate. As he was when I first met him, his nature seemed to be made up of exquisite half-tints, in which the most antagonistic tastes might find something to admire. It presented no sharp angles to wound your self-

esteem or your prejudices. Morally, intellectually, and physically, he was as smooth as velvet, and as agreeable to the touch. He never disagreed with you, whatever heterodox sentiments you might give vent to, and still no one could ever catch him in any positive inconsistency or self-contradiction. The extreme liberal who was on terms of intimacy with the nineteenth century, and passionately hostile to all temporal and spiritual rulers, put him down as a rising man, who might be confidently counted on when he should have shed his down and assumed

his permanent colors; and the prosperous conservative who had access to the private ear of the government lauded his good sense and his moderate opinions, and resolved to press his name at the first vacancy that might occur in the diplomatic service. In fact, every one parted from him with the conviction that at heart he shared his sentiments, even though for prudential reasons he did not choose to express himself with emphasis.

The inference, I am afraid, from all this, is that Dannevig was a hypocrite; but if I have conveyed that impression to any one, I certainly have done my friend injustice. I am not aware that he ever consciously suspended his convictions for the sake of pleasing; but convictions require a comparative depth of soil in order to thrive, and Dannevig's mind was remarkable for territorial expanse rather than for depth. Of course, he did with astonishing ease assume the color of the person he was talking with; but this involved, with him, no conscious mental process, no deliberate insincerity. It was rather owing to a kind of constitutional adaptability, an unconquerable distaste for quarreling, and the absence of any decided opinions of his own.

It was in the year 186-, just as the peace had been concluded between Prussia and Denmark, that I made Dannevig's acquaintance. He was then the hero of the day; all Copenhagen, as it seemed, had gone mad over him. He had just returned from the war, in which he had performed some extraordinary feat of fool-hardiness and saved seven companies by the sacrifice of his mustache. The story was then circulating in a dozen different versions, but, as nearly as I could learn, he had, in the disguise of a peasant, visited the Prussian camp on the evening preceding a battle and had acted the fool with such a perfection of art as to convince the enemy of his harmlessness. Before morning, however, he had furnished the Danish commander with important intelligence, thereby preventing the success of a surprise movement which the Prussians were about to execute. In return for this service he had been knighted on the battle-field, the order of Dannebrog having been bestowed upon him.

One circumstance that probably intensified the charm which Dannevig exerted upon the social circles of the Danish capital was the mystery which shrouded his origin. There were vague whisperings of lofty parentage, and even royal names were hinted

at, always, of course, in the strictest privacy. The fact that he hailed from France (though no one could say it for a certainty) and still had a Danish name and spoke Danish like a native, was in itself looked upon as an interesting anomaly. Then again, his easy, aristocratic bearing and his finely carved face suggested all manner of romantic possibilities; his long, delicate hands, the unobtrusive perfection of his toilet and the very texture of his handkerchiefs told plainly enough that he had been familiar with high life from the cradle. His way of living, too, was the subject of much curious comment. Without being really extravagant, he still spent money in a free-and-easy fashion, and always gave one the impression of having unbounded resources, though no one could tell exactly what they were. The only solution of the riddle was that he might have access to the treasury of some mighty man who, for reasons which perhaps would not bear publicity, felt called upon to support him.

I had heard his name abundantly discussed in academical and social circles and was thoroughly familiar with the hypothetical part of his history before chance led me to make his personal acquaintance. He had then already lost some of his first luster of novelty, and the professional yawners at club windows were inclining to the opinion that "he was a good enough fellow, but not made of stuff that was apt to last." But in the afternoon tea-parties, where ladies of fashion met and gently murdered each other's reputations, an allusion to him was still the signal for universal commotion; his very name would be greeted with clouds of ecstatic adjectives, and wild interjections and enthusiastic superlatives would fly buzzing about your ears until language would seem to be at its last gasp, and for a week to come the positive and comparative degrees would be applicable only to your enemies.

It was an open secret that the Countess von Brehm, one of the richest heiresses in the kingdom, was madly in love with him and would probably bestow her hand upon him in defiance of the wishes and traditions of her family. And what man, outside of the royal house, would be fool enough to refuse the hand of a Countess von Brehm?

II.

DURING the winter 1865-66, I met Dannevig frequently at clubs, student festivals,

and social gatherings, and his melodious voice, his epigrammatic talk, and his beauty never failed to extort from me a certain amount of reluctant admiration. I could not help noticing, however, that his charming qualities were all very much on the surface, and as for his beauty, it was of a purely physical kind. As a mere animal he could not have been finer. His eyes were as pure and blue and irresponsible as a pair of spring violets, and his face was as clean-cut and perfect as an ideal Greek mask, and as devoid of spiritual meaning. His animation was charmingly heedless and genuine, but nevertheless was mere surface glitter, and never seemed to be the expression of any really strong and heartfelt emotion. I could well imagine him pouting like Achilles over the loss of a lovely Briseis and bursting into vituperative language at the sight of the robber; but the very moment Briseis was restored his wrath would as suddenly have given way to the absolute bliss of possession.

The evening before my final departure from Copenhagen he gave a little party for me at his apartments, at which a dozen or more of our friends were invited.

I must admit that he was an admirable host. Without appearing at all to exert himself, he made every one feel at his ease, filled up every gap in the conversation with some droll anecdote or personal reminiscence, and still contrived to make us all imagine that we were entertaining instead of being entertained. The supper was a miracle of culinary skill, and the wines had a most refined and aristocratic flavor. He ate and drank with the deliberation and relish of a man who, without being exactly a gourmand, nevertheless counted the art of dining among the fine arts, and prided himself on being something of a connoisseur. Nothing, I suppose, could have ruined me more hopelessly in his estimation than if I had betrayed unfamiliarity with table etiquette,—if, for instance, I had poured Rhine wine into the white glasses, or sherry or Madeira into the blue.

As the hours of the night advanced, Dannevig's brilliancy rose to an almost dangerous height, which, as it appeared to us, could end in nothing short of an explosion. And the explosion came at last in the shape of a speech which I shall quote as nearly as the long lapse of years will permit.

After some mysterious pantomimic play directed toward a singularly noiseless and soft-mannered butler, our host rose, assumed

an attitude as if he were about to address the universe and spoke as follows:

"Gentlemen! As our distinguished friend here (all Americans, as you are aware, are born sovereigns and accordingly distinguished) is about to leave us, the spirit moves me to give voice to the feeling which animates us all at this peculiar juncture of events." (Here the butler returned with two bottles, which Dannevig seized and held up for general inspection.) "Bravo! here I hold in my hand a rare and potent juice, the condensed essence of all that is rich and fair and sweet in the history, character and climate of *la belle France*, a juice for which the mouths of princes have often watered in vain—in short a bottle of Château Yquem. I have my reasons for plucking the fairest bloom of my cellar on an occasion like this: for what I am about to say is not entirely in the nature of a compliment, and the genial influence of this royal wine will be needed to counteract the possible effects of my speech. In other words, I want the goodness of my wine to compensate for the rudeness of my intended remarks.

"America has never until now had the benefit of my opinion of her, which may in part account for the crudeness of her present condition. Now she has sent a competent emissary to us, who will return and faithfully report my sentiments, and if he does his work well, you may be prepared for revolutions beyond the Atlantic in decades to come. To begin with the beginning: the American continent, extending as it does from pole to pole, with a curious attenuation in the middle, always looked to me in my boyhood as a huge double bag flung across the back of the world; the symbolic sense of this form was not then entirely clear to me; but now, I think, I divine its meaning. As the centuries with their changing civilizations rolled over Europe, it became apparent to the Almighty that a spacious lumber-room was needed, where all the superfluous odds and ends that no longer fitted to the changed order of things might be stowed away for safe-keeping. Now, as you will frequently in a lumber-room, amid a deal of absolute dross, stumble upon an object of rare and curious value, so also in America you may, among heaps of human trumpery, be startled by the sparkle of a genuine human jewel. Our friend here, I need not add, is such a jewel, though cut according to the fashion of the last century, when men went wild over liberty and other illusory ideals, and

when, after having exhausted all the tamer kinds of dissipation, they amused themselves by cutting each other's heads off. Far be it from me to impute any such truculent taste to my honored guest. I only wish to observe that the land from which he hails has not yet outlived the revolutionary heresies of a century ago, that his people is still afflicted with those crude fever fantasies, of which Europe was only cured by a severe and prolonged bleeding. It has always been a perplexing problem to me, how a man who has seen the Old World can deliberately choose such a land as his permanent abode. I, for my part, should never think of taking such a step until I had quarreled with all the other countries of the world, one by one, and as life is too short for such an experience, I never expect to claim the hospitality of Brother Jonathan under his own roof.

"As regards South America, I never could detect its use in the cosmic economy, unless it was flung down there in the southern hemisphere purely as ballast, to prevent the globe from upsetting.

"Now, the moral of these edifying remarks is that I would urge my guest to correct, as soon as possible, the mistake he made in the choice of his birthplace. As a man never can be too circumspect in the selection of his parents, so neither can he exercise too much caution in the choice of his country. My last word to thee is: 'Fold thy tent, and pitch it again where mankind, politics, and cookery are in a more advanced state of development.' Friends, let us drink to the health of our guest, and wish for his speedy return."

I replied with, perhaps, some superfluous ardor to this supercilious speech, and a very hot discussion ensued. When the company finally broke up, Dannevig, fearing that he had offended me, laid his arm confidentially on my shoulder, drew me back from the door, and pushed me gently into an easy-chair.

"Look here!" he said, planting himself in front of me. "It will never do for you and me to part, except as friends. I did not mean to patronize you, and if my foolish speech impressed you in that way, I beg you to forgive me."

He held out his long, beautiful hand, which after some hesitation I grasped, and peace was concluded.

"Take another cigar," he continued, throwing himself down on a damask-covered lounge opposite me. "I am in a confiding mood to-night, and should like to tell

you something. I feel an absolute need to unbosom myself, and Fate points to you as the only safe receptacle of my confidence. After to-morrow, the Atlantic will be between us, and if my secret should prove too explosive for your reticence, your indiscretion will do me no harm. Listen, then. You have probably heard the town gossip connecting my name with that of the Countess von Brehm."

I nodded assent.

"Well, my modesty forbids me to explain how far the rumor is true. But, the fact is, she has given me the most unmistakable proofs of her favor. Of course, a man who has seen as much of the world as I have cannot be expected to reciprocate such a passion in its sentimental aspects; but from its—what shall I say?"

"Say, from a financial point of view it is not unworthy of your consideration," I supplied, unable to conceal my disgust.

"Well, yes," he resumed blandly, "you have hit it. However, I am by no means blind to her fascination. Moreover, the countess has a latent vein of fierceness in her nature which in time may endear her to my heart. Last night, for instance, we were at a ball at the Baron P——'s, and we danced together incessantly. While we were whirling about to the rhythm of an intoxicating melody, I, feeling pretty sure of my game, whispered half playfully in her ear: 'Countess, what would you say, if I should propose to you?' 'Propose and you will see,' she answered gravely, while those big black eyes of hers flashed at me until I felt half ashamed of my flippancy. Of course I did not venture to put the question then and there, although I was sorely tempted. Now, that shows that she has spirit, to say the least. What do you think?"

"I think," I answered, with emphasis, "that if I were a friend of the Countess von Brehm, I should go to her to-morrow and implore her to have nothing to do with you."

"By Jove," he burst forth, laughing; "if I were a friend of the countess, I should do the very same thing; but being her lover, I cannot be expected to take such a disinterested view of the case. Moreover, my labor would be thrown away; for, *entre nous*, she is too much in love with me."

I felt that if I stayed a moment longer we should inevitably quarrel. I therefore rose, somewhat abruptly and pulled on my overcoat, averring that I was tired and

should need a few hours of sleep before embarking in the morning.

"Well," he said, shaking my hand heartily, as we parted in the hall, "if ever you should happen to visit Denmark again, you must promise me that you will look me up. You have a standing invitation to my future estate."

III.

SOME three years later I was sitting behind my editorial desk in a newspaper office in Chicago, and the impressions from my happy winter in Copenhagen had well nigh faded from memory. The morning mail was brought in, and among my letters I found one from a Danish friend with whom I had kept up a desultory correspondence. In the letter I found the following paragraph:

"Since you left us, Dannevig has been going steadily down hill, until at last his order of Dannebrog just managed to keep him respectable. About a month ago he suddenly vanished from the social horizon, and the rumor says that he has fled from his numerous creditors and probably now is on his way to America. His resources, whatever they were, gradually failed him, while his habits remained as extravagant as ever. If the popular belief is to be credited, he lived during the two last years on his prospect of marrying the Countess von Brehm, which prospect in Copenhagen was always convertible into cash. The countess, by the way, was unflinching in her devotion to him, and he would probably long ago have led her to the altar, if her family had not so bitterly opposed him. The old count, it is said, swore that he would disinherit her, if she ever mentioned his name to him again; and those who know him feel confident that he would have kept his word. The countess, however, was quite willing to make that sacrifice, for Dannevig's sake; but here, unfortunately, that cowardly prudence of his made a fool of him. He hesitated and hesitated long enough to wear out the patience of a dozen women less elevated and heroic than she is. Now the story goes that the old count, wishing at all hazards to get him out of the way, made him a definite proposition to pay all his debts and give him a handsome surplus for traveling expenses, if he would consent to vanish from the kingdom for a stated term of years. And according to all appearances Dannevig has been fool enough to accept the offer. I should not be surprised if you would hear from him before long, in which case I trust you will keep me informed of his movements. A Knight of Dannebrog, you know, is too conspicuous a figure to be entirely lost beneath the waves of your all-leveling democracy. Depend upon it, if Dannevig were stranded upon a desert isle, he would in some way contrive to make the universe aware of his existence. He has, as you know, no talent for obscurity; there is a spark of a Caesar in him, and I tremble for the fate of your constitution if he stays long enough among you."

Four months elapsed after the receipt of this letter, and I had almost given up the expectation (I will not say hope) of seeing

Dannevig, when one morning the door to my office was opened, and a tall, blonde-haired man entered. With a certain reckless grace, which ought to have given me the clue to his identity, he sauntered up to my desk and extended his hand to me.

"Hallo, old boy!" he said, with a weak, weary smile. "How are you prospering? You don't seem to know me."

"Heavens!" I cried, "Dannevig! No, I didn't know you. How you have altered!"

He took off his hat, and flung himself into a chair opposite me. His large, irresponsible eyes fixed themselves upon mine, with a half-daring, half-apologetic look, as if he were resolved to put the best face on a desperate situation. His once so ambitious mustache drooped despondingly, and his unshaven face had an indescribably withered and dissipated look. All the gloss seemed to have been taken off it, and with it half its beauty and all its dignity had departed.

"Dannevig," I said, with all the sympathy I had at my command, "what *has* happened to you? Am I to take your word for it, that you have quarreled with all the world, and that this is your last refuge?"

"Well," he answered, evasively, "I should hardly say that. It is rather your detestable democratic cookery which has undone me. I haven't had a decent meal since I set my foot on this accursed continent. There is an all-pervading plebeian odor of republicanism about everything one eats here, which is enough to ruin the healthiest appetite, and a certain barbaric uniformity in the bill of fare which would throw even a Diogenes into despair. May the devil take your leathery beef-steaks, as tough as the prose of Tacitus, your tasteless, nondescript buckwheats, and your heavy, melancholy wines, and I swear it would be the last you would hear of him!"

"There! that will do, Dannevig!" I cried, laughing. "You have said more than enough to convince me of your identity. I do admit I was skeptical as to whether this could really be you, but you have dispelled my last doubts. It was my intention to invite you to dine with me to-day, but you have quite discouraged me. I live quite *en garçon*, you know, and have no Château Yquem nor pheasant à la *Sainte Alliance*, and whatever else your halcyon days at the Café Anglais may have accustomed you to."

"Never mind that. Your company will in part reconcile me to the republicanism of your table. And, to put the thing bluntly, can you lend me thirty dollars? I have

pawned my only respectable suit of clothes for that amount, and in my present costume I feel inexpressibly plebeian,—very much as if I were my own butler, and—what is worse—I treat myself accordingly. I never knew until now how much of the inherent dignity of a man can be divested with his clothing. Then another thing: I am absolutely forced to do something, and, judging by your looks, I should say that journalism was a profitable business. Now, could you not get me some appointment or other in connection with your paper? If, for instance, you want a Paris correspondent, then I am just your man. I know Paris by heart, and I have hob-nobbed with every distinguished man in France."

"But we could hardly afford to pay you enough to justify you in taking the journey on our account."

"*O sancta simplicitas!* No, my boy, I have no such intention. I can make up the whole thing with perfect plausibility, here under your own roof; and by a little study of the foreign telegrams, I would undertake to convince Thiers and Jules Favre themselves that I watched the play of their features from my private box at the French opera, night before last, that I had my eye at the key-hole, while they performed their morning ablutions, and was present as eavesdropper at their most secret councils. Whatever I may be, I hope you don't take me to be a chicken."

"No," I answered, beguiled into a lighter mood by his own levity. "It might be well for you if you were more of one. But as Paris correspondent, we could never engage you, at least not on the terms you propose. But even if I should succeed in getting a place for you, do you know English enough to write with ease?"

"I see you are disposed to give vent to your native skepticism toward me. But I never knew the thing yet that I could not do. At first, perhaps, I should have to depend somewhat upon your proof-reading, but before many months, I venture to say, I could stand on my own legs."

After some further parley it was agreed that I should exert myself in his behalf, and after a visit to the pawnbroker's, where Dannevig had deposited his dignity, we parted with the promise to meet again at dinner.

IV.

It was rather an anomalous position for a knight of Dannebrog, a familiar friend

of princes, and nobles, and an *ex-habitué* of the Café Anglais, to be a common reporter on a Chicago republican journal. Yet this was the position to which (after some daring exploits in book-reviewing and art criticism) my friend was finally reduced. As an art critic, he might have been a success, if western art had been more nearly in accord with his own fastidious and exquisitely developed taste. As it was, he managed in less than a fortnight to bring down the wrath of the whole artistic brotherhood upon our journal, and as some of these men were personal friends of the principal stockholders in the paper, his destructive ardor was checked by an imperative order from the authorities, from whose will there is no appeal. As a book-reviewer he labored under similar disadvantages; he stoutly maintained that the reading of a volume would necessarily and unduly bias the critic's judgment, and that a man endowed with a keen, literary nose could form an intelligent opinion, after a careful perusal of the title-page, and a glance at the preface. A man who wrote a book naturally labored under the delusion that he was wiser or better than the majority of his fellow-creatures, in which case you would do him a moral service by convincing him of his error. If humanity continued to encourage authorship at the present rate, obscurity would soon become a claim to immortality. If a writer informed you that his work "filled a literary void," his conceit was reprehensible, and on moral grounds he ought to be chastised; if he told you that he had only "yielded to the urgent request of his friends," it was only fair to insinuate that his friends must have had very long ears. Nevertheless, Dannevig's reviews were for about a month a very successful feature of our paper. They might be described as racy little essays, bristling with point and epigram, on some subject suggested by the title-pages of current volumes. At the end of that time, however, books began to grow scarce in our office, and before another month was at an end, we had no more need of a reviewer. My friend was then to have his last trial as a reporter.

One of his first experiences in this new capacity was at a mass-meeting preceding an important municipal election. Not daring to send his "copy" to the printer without revision, I determined to sacrifice two or three hours' sleep, and await his return. But the night wore on, the clock struck twelve,

one, and two, and no Dannevig appeared. I began to grow anxious; our last form went to press at four o'clock, and I had left a column and a half open for his expected report. Not wishing to resort to dead matter, I hastily made some selections from a fresh magazine, and sent them to the foreman.

The next day, about noon, a policeman brought me the following note, written in pencil, on a leaf torn from a pocket-book.

DEAR FRIEND :

I made a speech last night (and a very good one too) in behalf of oppressed humanity, but its effect upon my audience was, to say the least, singular. Its results, as far as I am personally concerned, were also somewhat unpleasant. Looking at myself in my pocket-glass this morning, I find that my nose has become disproportionately prominent, besides showing an abnormal lateral development. If you would have the goodness to accompany the obliging gentleman, who is the bearer of this, to my temporary lodgings, I will further explain the situation to you. By the way, it is absolutely necessary that you should come.

Yours in haste,

VICTOR J. ST. D. DANNEVIG,
R. D. O.*

I found Dannevig, as I had expected, at the so-called Armory (the city prison), in pleasant converse with half-a-dozen policemen, to whom he was describing, with inimitable grace and good-humor, his adventures of the preceding night. He was too absorbed in his narrative to notice my arrival, and I did not choose to interrupt him.

"You can imagine, gentlemen," he was saying, accompanying his words with the liveliest gesticulations, "how the rude contact of a plebeian fist with my tender skin must have impressed me. Really, gentlemen, I was so surprised that I literally lost my balance. I was, as you are no doubt aware, merely asserting my rights as a free citizen to protest against the presumptions of the unprincipled oligarchy which is at present ruling this fair city. My case is exactly parallel to that of Caius Gracchus, who, I admit, reaped a similar reward."

"But you were drunk," replied a rude voice from his audience. "Dead drunk."

"Drunk," ejaculated Dannevig, with a gesture of dignified deprecation. "Now, I submit it to you as gentlemen of taste and experience: how would you define that state of mind and body vulgarly styled 'drunk?' I was merely pleasantly animated as far as such a condition can be induced by those vulgar liquids which you are in the habit of imbibing in this benighted country. Now,

if I had had the honor of your acquaintance in the days of my prosperity, it would have given me great pleasure to raise your standard of taste regarding wines and alcoholic liquors. The mixed drinks, which are held in such high esteem in this community, are, in my opinion, utterly demoralizing."

Thinking it was high time to interrupt this discourse, I stepped up to the orator, and laid my hand on his shoulder.

"Dannevig," I said, "I have no time to waste. Let me settle this business for you at once."

"In a moment I shall be at your service," he answered, gracefully waving his hand; and for some five minutes more he continued his harangue on the corrupting effects of mixed drinks.

After a visit to the court-rooms, a brief examination, and the payment of a fine, we took our departure. Feeling in an exceptionally amiable mood, Dannevig offered me his arm, and as we again passed the group of policemen at the door, he politely raised his dilapidated hat to them, and bade them a pleasant good-morning. The cross of Dannebrog, with its red ribbon, was dangling from the button-hole of his coat, the front of which was literally glazed with the stains of dried punch.

"My type of countenance, as you will observe," he remarked, as we hailed a passing omnibus, "presents some striking deviations from the classic ideal; but it is a consoling reflection that it will probably soon resume its normal form."

Of course, all the morning as well as the evening papers, recounted, with flaming headings, Dannevig's oration, and his ignominious expulsion from the mass-meeting, and the most unsparing ridicule was showered both upon him and the journal which, for the time, he represented. One more experience of a similar nature terminated his career as a journalist; I dared no longer espouse his cause, and he was dismissed in disgrace. For some weeks he vanished from my horizon, and I began to hope that he had again set his face toward the old world, where talents of the order he possessed are at higher premium in the social market. But in this hope I was to be grievously disappointed.

V.

ONE day, just as I had ordered my lunch at a restaurant much frequented by journalists, a German named Pfeifer, one of the

* Knight of the Order of Dannebrog.

largest stockholders in our paper, entered and seated himself at the table opposite me. He was a somewhat puffy and voluminous man with a very round bald head, and an air of defiant prosperity about him. He had retired from the brewery business some years ago, with a very handsome fortune.

"I have been hunting for you high and low," he began in his native tongue. "You know there is to be a ball in the *Turnverein* to-morrow night,—a very grand affair, they say. I suppose they have sent you tickets."

"Yes, two."

"And are you going?"

"I had half made up my mind to send Fenner or some one else."

Mr. Pfeifer here grew superfluously confidential and related to me in a mysterious whisper his object in seeking me. The fact was, he had a niece, really *ein allerliebstes Kind*, who had come from Milwaukee to visit him and was to spend the winter with him. Now, to be honest, he knew very few young gentlemen whom he would be willing to have her associate with, and the poor child had set her heart on going to the *Turnball* to-morrow. Would I kindly overlook the informality of his request, and without telling the young lady of his share in the proceeding, offer her my escort to the ball? Would I be responsible for her and bring her home in good season? And to avert Fräulein Pfeifer's possible suspicions, would I come and dine at his house to-night and make her acquaintance?

To refuse the acquaintance of a young lady who even remotely answered to the description of "a very lovely child," was contrary to my principles, and I need not add that I proved faithful to them in the present instance.

A German, even if he be not what one would call a cultivated man, has nevertheless a certain somber historic background to his life which makes him averse to those garish effects of barbaric splendor that impress one so unpleasantly in the houses of Americans whose prosperity is unsupported by a corresponding amount of culture. This was my first reflection on entering Mr. Pfeifer's drawing-room, while in my heart I begged the proprietor's pardon for the patronizing attitude I found myself assuming toward him. The heavy solid furniture, the grave and decorously mediocre pictures, and the very tint of the walls wore an air of substantial, though somewhat lugubrious, comfort. His niece, too, although her form was by no means lacking in grace, seemed somehow to partake of this all-

pervading air of Teutonic solidity and homelike comfort. She was one of those women who seemed born to make some wretched man undeservedly happy. (I always feel a certain dim hostility to any man, even though I may not know him, who marries a charming and lovable woman; it is with me a foregone conclusion that he has been blessed beyond his deserts.) There was a sweet matronliness in the quiet dignity of her manner, and beneath the placid surface of her blue eyes I suspected hidden depths of pure maidenly sentiment. The cast of her countenance was distinctly Germanic; not strikingly beautiful, perhaps, but extremely pleasing; there was no discordant feature in it, no loud or harsh suggestion to mar the subdued richness of the whole picture. Her blonde hair was twisted into a massive coil on the top of her head, and the unobtrusive simplicity and taste of her toilet were merely her character (as I had conceived it) translated into millinery. My feelings, as I stood gazing at her, unconsciously formulated themselves into the well-known benediction of Heine's, which I could with difficulty keep from quoting:

"Mir ist als ob ich die Hände
Auf's Haupt dir legen sollt',
Betend dass Gott dich erhalte
So rein und schön und hold."

I observed with quiet amusement, though in a very sympathetic spirit, that she did not manage her train well; and from the furtive attention she was ever bestowing upon it, I concluded, that her experience with long dresses must have been of recent date. I noticed, too, as she came forward to salute me, that her hands were not unused to toil; but for this I only honored her the more.

The dinner was as serious and substantial as every thing else in Mr. Pfeifer's house, and passed off without any notable incident. The host persisted in talking business with me, which the young lady, at whose side I sat, accepted as a matter-of-course, making apparently no claim whatever upon the smallest share of my attention. When the long and tedious meal was at an end, upon her uncle's suggestion, she seated herself at the piano, and sang in a deep, powerful contralto, Schubert's magnificent arrangement of Heine's song of unrequited love:

"Ich grolle nicht, und wenn dass Herz auch bricht,
Ewig verlor'nes Lieb! ich grolle nicht.
Wie du auch strahlst in Diamantenpracht,
Es fällt kein Strahl in deines Herzens Nacht."

There was a pathos and passion in her voice which fairly startled me, and when I hastened to her side to thank her for the pleasure she had given me, she accepted my compliments with a beautiful, unaffected enthusiasm, as if they were meant only for the composer, and were in no respect due to her.

"There is such a depth of suffering in every word and note," she said with glowing cheeks. "He bears her no ill will, he says, and still you feel how the suppressed bitterness is still rankling within him."

She then sang "Auf Flügeln des Gesanges," whereupon we sat down and talked music and Heine for the rest of the evening. Mr. Pfeifer, reclining in his capacious easy-chair, smoked on with slow, brooding contentment, and now and then threw in a disparaging remark regarding our favorite poet.

"He blackguarded his country abominably," he said. "And I have no respect for a man who can do that. Besides, he was a miserable, renegade Jew, and as I never like to have any more to do with Jews than I can possibly help, I have never read any of his books."

"But, uncle," retorted his niece, warmly, "he certainly could not help being a Jew. And there was no one who loved Germany more ardently than he, even though he did say severe things about it."

"That is a thing about which you can have no opinion, Hildegard," said Pfeifer, with paternal decision, and he blew a dense cloud of smoke toward the ceiling.

Miss Hildegard looked rebellious for an instant, but accepted the verdict of superior wisdom with submissive silence. The old man gave me a little confidential wink as if to say:

"There is a model girl for you. She knows that women should not speak in meeting."

"What a delightfully fresh and unspoiled girl," I reflected, as I wended my way homeward through the still moonlight; "so true-hearted, and genuine, and unaffected. And still beneath all that sweet, womanly tranquillity there are strong slumbering forces, which some day will startle some phlegmatic countryman of hers, who takes her to be as submissive as she looks."

VI.

SOME fifteen minutes after the appointed hour I called with a carriage for Fräulein

Hildegard, whom, to my wonder, I found standing in all the glory of her ball-toilet (for she was evidently afraid to sit down) in the middle of the somber drawing-room. I had been prepared to wait for a good half hour, and accordingly felt a little provoked at myself for my seeming negligence.

"I do not mind telling you," she said, as I sat compressed in a corner of the carriage, striving to reduce myself to the smallest practicable dimensions, "that this is my first ball. I don't know any of the gentlemen who will be there to-night, but I know two or three Milwaukee ladies who have promised to come, so, even if I don't dance much, I shall not feel lonely."

"Of course you will give me the first chance at your card," I answered. "How many dances will you grant me?"

"As many as you want. Uncle was very explicit in impressing upon me that I am to obey you unquestioningly and have no will of my own."

"That was very unkind of him. I shall be unwilling to claim any privilege which you do not of your own free will bestow upon me."

"I didn't mean it so," she answered, impulsively, and by the passing light of a gas-lamp I caught a glimpse of her beaming, innocent face. "I shall not be apt to forget that I am indebted to your kindness for all the pleasure I shall have to-night, and if you wish to dance with me, of course it is very kind of you."

"Well, that is not much better," I murmured, ruefully, feeling very guilty at heart. "On that ground I should be still more reluctant to assert my claim on you."

"Oh, what a bungler I am!" she exclaimed, with half-amused regret. "The truth is, I am so glad, and when I am very happy I always make blundering speeches."

As we entered the magnificently lighted and decorated hall, I noticed, to my dismay, that the company was a little more mixed than I had anticipated. I had, therefore, no scruples in putting down my name for four waltzes and a quadrille. I observed, too, that my fair partner attracted much attention, partly, perhaps, on account of her beauty, and partly on account of her superb toilet. Her dress was of satin of a cool, lucid, sea-green tint, such as one sees in the fjords of Norway on a bright summer's day; the illusion was so perfect that in dancing with her I expected every moment to see sea-weeds and pale-green things sprouting up along its border, and the

white bunches of lilies-of-the-valley in her hair, as they wafted their faint fragrance toward me, seemed almost an anomaly. She danced, not with vehement abandon, but with an airy, rhythmical grace, as if the music had entered into her soul and her limbs were but obeying their innate tuneful impulse. When we had finished the first waltz, I left her in the company of one of her Milwaukee friends and started out in quest of some acceptable male partner whose touch of her I should not feel to be a positive desecration. I had reached about the middle of the hall when an affectionate slap on my shoulder caused me to turn around.

"Dannevig!" I exclaimed, with frigid amazement. "By Jove! Where do you come from? You are as unexpected as a thunderclap from a cloudless sky."

"Which was a sign that Jupiter was wrath," replied Dannevig, promptly, "and required new sacrifices. Now the sacrifice I demand of you is that you shall introduce me to that charming little girl you have had the undeserved luck of securing."

"You choose your metaphors well," I remarked, calmly. "But, as you know, even the Romans with all their reputed hardness of heart, were too conscientious to tolerate human sacrifices. And I, being, in the present instance, the *pontifex*, would never be a party to such an atrocity."

The transformation which Dannevig's face underwent was almost terrible. A look of perfectly animal savageness distorted for a brief moment his handsome features; his eyes flashed, and his brow was one mass of wrinkles.

"Do you mean to say that you refuse to introduce me?" he asked, in a hoarse whisper.

"That is exactly what I mean to say," I answered, with well-feigned coolness.

"And do you really suppose," he continued, while his brow slowly relaxed, "that you can prevent me from making that girl's acquaintance if I made up my mind to thwart you?"

"I don't suppose anything of the kind," was my reply. "But you know me well enough to be aware that you can not brow-beat me. She shall, at all events, not owe your acquaintance to me."

Dannevig stood for a while, pondering; then, with one of those sudden transitions of feeling which were so characteristic of him, he continued in a tone of good fellowship:

"Come, now; this is ridiculous! You have been dining on S——'s leathery beef-steak, which I have so frequently warned you against, and, what is worse, you have had mince pie for dessert. Your digestion is seriously deranged. For old friends like you and me to quarrel over a little chit of a girl, is as absurd as committing suicide because you have scratched your hand with a pin. If your heart is really engaged in this affair, then I wont interfere with you. I wish you luck, although judging by what I have seen, I should say you might have made a better choice. *Au revoir.*"

He skipped lightly down the floor, and was lost in the crowd. Having selected some journalistic friends as partners for Fräulein Hildegard, and listened with great patience to their rhapsodies over her beauty and loveliness, I stationed myself at the upper end of the hall, and in philosophic discontent watched the dancers. Dannevig's parting words had filled me with vague alarm; I knew that they were insincere, and I suspected that he was even now at work to accomplish some disastrous intention. At this moment a couple came whirling straight toward me; a pale-green satin train swept over my feet, and the cross of the order of Dannebrog sent a swift flash into my very eyes. A fierce exclamation escaped me; my blood was in tumult. I began to feel dangerous. As the usual accelerated rush of violins and drums announced that the dance was near its end, I did not dare to seek my fair partner, and I had no pleasure to feign when I saw her advancing, with a light and eager step, to where I was standing. She was evidently too pre-occupied to notice the change I had undergone since our last parting.

"Now," she said, with as near an approach to archness as a woman of her type is capable of, "you must not think me odd if I do something that may seem to you a little bit unconventional. It is only your own kindness to me which encourages me to ask you a favor, which I shouldn't wonder if you would rather grant than not. The fact is, there is a gentleman who wishes very much to dance with me, and my card is already full. Now, would you mind giving up one of yours? I know, in the first place, that it was from a sense of duty that—that—that you took so many," she finished desperately, as I refused to come to her aid.

"We will not discuss my motives, Fräulein," I said, with as much friendliness as I had at my command. "But, before grant-

ing your not unreasonable request, you must be good enough to tell me who the gentleman is who is to profit by my sacrifice."

"His name is Mr. Dannevig. He is a knight of Dannebrog, and moreover, as he tells me, an intimate friend of yours."

"Tell him, then, Fräulein, that he might have presumed sufficiently upon our friendship to prefer his request in person, instead of sending you as his messenger."

The color sprang to her cheeks; she went abruptly around, and with an air of outraged majesty, marched defiantly down the hall.

The night wore on. The hour for supper came, and politeness forced me to go and find Miss Pfeifer. Then we sat down in a corner, and ate and chatted in a heedless, dispirited fashion, dwelling with feigned interest on trifling themes, and as by a tacit agreement avoiding each other's glances. Then some gentleman came to claim her, and I was almost glad that she was gone. And yet, in the very next moment a passionate regret came over me, as for a personal loss, and I would fain have called her back and told her, with friendly directness, my reasons for interfering so rudely with her pleasure.

I do not know how long I sat thus idly nursing my discontent, and now and then, as my anger blazed up, muttering some fierce execration against Dannevig. What was this girl to me, after all? I was certainly not in love with her. And if she chose to ruin herself, what business had I to prevent her? But then, she was a woman, and a sweet and pure and true-hearted woman; it was, at all events, my duty to open her eyes, and I vowed that, even though she should hate me for it, I would tell her the truth. I looked at my watch; it was a few minutes past two. With a sting of self-reproach, I remembered my promise to Mr. Pfeifer, and resolved not to shirk the responsibility I had voluntarily assumed. I hastened up the hall, then down again, surveyed the dancers, sent a girl into the dressing-room with a message; but Fräulein Hildegard was nowhere to be seen. A horrible thought flashed through me. I seized my hat, and rushed down into the restaurant. There, in an inner apartment, divided from the public room by drooping curtains, I found her, laughing and chatting gayly with Dannevig over a glass of Rhine wine and a dish of ice-cream.

"Fräulein," I said, approaching her with grave politeness, "I am sorry to be obliged to interrupt this agreeable *tête-à-tête*. But

the carriage has arrived, and I must claim the pleasure of your company."

"Now, really," she exclaimed, with impulsive regret, while her eyes still hung with a fascinated gaze on Dannevig's face, "is it, then, so necessary that we should go just now? Do you really insist upon it? Mr. Dannevig was just telling me some charming adventures of his life in Denmark."

"I am happy to say," I answered, "that I am so well familiar with Mr. Dannevig's adventures as to be quite competent to supplement his fragmentary statements. I shall be very happy to continue the entertainment —"

"*Sacré-à-à-à nom de Dieu!*" Dannevig burst forth, leaping up from his seat. "This is more than I can bear!" and he pulled a card from his portmonnaie and flung it down on the table before me. "May I request the honor of a meeting?" he continued, in a calmer voice. "It is high time that we two should settle our difficulties in the only way in which they are capable of adjustment."

"Mr. Dannevig," I replied, with a cool irony which I was far from feeling. "The first rule of the code of honor, to which you appeal, is, as you are aware, that the combatants must be equals in birth and station. Now, you boast of being a knight of Dannebrog, while I have no such claim to distinction. You see therefore that your proposition is absurd."

Miss Hildegard had in the meanwhile risen to take my proffered arm, and with a profound bow to the indignant hero we moved out of the room. During our homeward ride hardly a word was spoken; the wheels rattled away over the cobble-stones, and the coachman snapped his whip, while we sat in opposite corners of the carriage, each pursuing his or her own lugubrious train of thought. But as we had mounted together the steps to Mr. Pfeifer's mansion, and I was applying her latch-key to the lock, she suddenly held out her hand to me, and I grasped it eagerly and held it close in mine.

"Really," she said in a tone of conciliation, "I like you too well to wish to quarrel with you. Wont you please tell me candidly why you objected to my dancing with Mr. Dannevig?"

"With all my heart," I responded warmly; "if you will give me the opportunity. In the meanwhile you will have to accept my reasons on trust, and believe that they were very weighty. You may

feel assured that I should not have run the risk of offending you, if I had not felt convinced that Dannevig is a man whose acquaintance no young lady can claim with impunity. I have known him for many years and I do not speak rashly."

"I am afraid you are a very severe judge," she murmured sadly. "Good-night."

VII.

DURING the next months many rumors of Dannevig's excesses reached me from various sources. He had obtained a position as interpreter of one of the Immigration Companies, and made semi-monthly excursions to Quebec, taking charge of the immigrants, and conducting them to Chicago. The opportunity for revealing his past history to Miss Pfeifer somehow never presented itself, although I continued to call frequently, and spent many delightful evenings with her and her uncle. However, I consoled myself with the reflection that the occasion for such a revelation no longer existed, and I had no desire needlessly to persecute a man whose iniquities could, at all events, harm no one but himself. And still, knowing from experience his talent for occult diplomacy, I took the precaution (without even remotely implicating Miss Hildegard) to put Mr. Pfeifer on his guard. One evening as we were sitting alone in his library enjoying a confidential smoke, I related to him, merely as part of the secret history of our paper, some of Dannevig's questionable exploits while in our employ. Pfeifer was hugely entertained, and swore that Dannevig was the most interesting rascal he had ever heard of.

A few days later I was surprised by a call from Dannevig, who seemed again to be in the full bloom of prosperity. And yet, that inexpressible flavor of aristocracy and that absolute fineness of type which at our first meeting had so fascinated me, had undergone some subtle change which was almost too fleeting for words to express. To put it bluntly, he had not borne transplantation well. Like the finest European grapes, he had thriven in our soil, but turned out a coarser product than nature intended. He talked with oppressive brilliancy about everything under the sun, patronized me (as indeed he had always done), and behaved with a certain effusive, amiability, the impudence of which was simply masterly.

"By the way," he cried, with fine unconcern, "speaking of beer, how is your friend,

Miss Pfeifer? Her old man, I believe, owns a good deal of stock in this paper, quite a controlling interest, I am told."

"It will not pay to make love to her on that ground, Dannevig," I answered, gravely, knowing well enough that he had come on a diplomatic errand. "Mr. Pfeifer is, in the first place, not her father, and secondly, he has at least a dozen other heirs."

"Make love to Miss Pfeifer!" he exclaimed, with a hearty laugh. "Why, I should just as soon think of making love to General Grant! Taking her all in all, bodily and mentally, there is a certain Teutonic heaviness and tenacity about her—a certain professional ponderosity of thought which would give me a nightmare. She is the innocent result of twenty generations of beer-drinking."

"Suppose we change the subject, Dannevig," I interrupted, rather impatiently.

"Well, if you are not the oddest piece I ever did come across!" he replied, laughingly. "You don't suppose she is a saint, do you?"

"Yes, I do!" I thundered, "and you would greatly oblige by never mentioning her name again in my presence, or I might be tempted to do what I might regret."

"Heavens!" he cried, laying hold of the door-knob. "I didn't know you were in your dangerous mood to-day. You might at least have given a fellow warning. Suppose, henceforth, when you have your bad days, you post a placard on the door, with the inscription: 'Dangerous—must not be crossed.' Then I might know when not to call. Good-morning."

On the lake shore, a short distance north of Lincoln Park, Mr. Pfeifer had a charming little villa, where he spent the summer months in idyllic drowsiness, exhibiting a spasmodic interest in the culture of European grapes. Here I found myself one Saturday evening in the middle of June, having accepted the owner's invitation to stay over Sunday with him. I rang the door-bell and inquired for Mr. Pfeifer. He had unexpectedly been called in to town, the servant informed me, but would return presently; the young lady I would probably find in the garden. As I was not averse to a *tête-à-tête* with Miss Hildegard just then, I threaded my way carefully among the flower-beds, whose gorgeous medley of colors gleamed indistinctly through the twilight. A long bar of deep

crimson traced itself along the western horizon, and here and there a star was struggling out from the faint, blue, nocturnal dimness. Green and red and yellow lights dotted the surface of the lake, and the waves beat, with a slow, gurgling rhythm against the strand beneath the garden fence; now and then the irrational shrieks of some shrill-voiced little steamer broke in upon the stillness like an inappropriately lively remark upon a solemn conversation. I had half forgotten my purpose and was walking aimlessly on, when suddenly I was startled by the sound of human voices, issuing apparently from a dense arbor of grape-vines at the lower end of the walk.

"Why will you not believe me, darling?" some one was saying. A great rush of emotion—fear, anguish, hatred, shook my very soul. "Your skepticism would make Tyndall tear his hair. Angels have no business to be so skeptical. You are always doubting me, always darkening my life by your irrational fears."

"But, Victor," answered another voice, which was none other than Hildegard's, "he is certainly a very good man, and would not tell me anything he believed to be untrue. Why, then, did he warn me so solemnly against you? Even though I love you, I cannot help feeling that there is something in your past which you hide from me."

"If you will listen to that white-livered hypocrite, it is useless for me to try to convince you. But, if you must know it,—though, mind you, I tell you this only because you compel me,—I once interfered, because my conscience forced me to do so, in a very disgraceful love-affair of his in Denmark. He has hated me ever since, and is now taking his vengeance. I will give you the details some other time. Now, are you satisfied?"

"No, Victor, no. I am not. It is not because I have been listening to others, that I torment you with these ungrateful questions. Sometimes a terrible dread comes over me, and though my heart rebels against it, I can not conquer it. I feel as if some dark memory, some person, either living or dead, were standing between us, and would ever keep you away from me. It is terrible, Victor, but I feel it even now."

"And then all my love, my first and only abiding passion, my life, which I would gladly lay down at your feet—all goes for naught, merely because a foolish

dream has taken possession of you. Ah, you are ill, my darling, you are nervous."

"No, no, do not kiss me. Not to-night, Victor, not to-night."

The horrible discovery had completely stunned me. I stood as if spell-bound, and could neither stir nor utter a sound. But a sudden rustling of the leaves within broke through the torpor of my senses, and, with three great strides, I stood at the entrance to the arbor. Dannevig, instantly recognizing me, slipped dexterously out, and in the next moment I heard him leaping over the fence, and running away over the crisp sand. Miss Hildegard stood still and defiant before me in the twilight, and the audible staccato of her breath revealed to my ears the agitation which the deepening shadows hid from my eyes. An overwhelming sense of compassion came over me, as for one who had sustained a mortal hurt that was beyond the power of healing. Alas, that simplicity and uprightness of soul, and the boasted womanly intuitions, should be such poor safeguards against the wiles of the serpent! And yet, I knew that to argue with her at this moment would be worse than vain.

"Fräulein," I said, walking close up to her, and laying my hand lightly on her arm, "with all my heart I deplore this."

"Pray do not inconvenience yourself with any such superfluous emotion," she answered, in a tone, the forced hauteur of which was truly pathetic. "I wish to hear no accusations of Mr. Dannevig from your mouth. What he does not choose to tell me himself, I will hear from no one else."

"I have not volunteered any revelations, Fräulein," I observed. "Moreover, I see you are posing for your own personal gratification. You wish to convince yourself of your constancy by provoking an attack from me. When love has reached that stage, Miss Hildegard, then the patient is no longer absolutely incurable. Now, to convince you that I am right, will you have the kindness to look me straight in the eyes and tell me that there is no shadow of doubt in your heart as to Mr. Dannevig's truthfulness; that, in other words, you believe that on one occasion he assumed the attitude of indignant virtue toward me, and in holy horror rebuked my profligacy. Dare you meet my eye, and tell me that?"

"Yes," she exclaimed, boldly stepping out into the moonlight, and meeting my eye with a steady gaze; but slowly and gradually the tears *would* gather, her under-

lip *would* quiver, and with a sudden movement she turned around, and burst out weeping.

"Oh, no! I cannot! I cannot!" she sobbed, sinking down upon the green sod.

I stood long gazing mournfully at her, while the sobs shook her frame; there was a child-like, hearty abandon in her grief, which eased my mind, for it told me that infatuation was not so hopeless, nor her hurt so great as I had feared.

The next evening when dinner was at an end, Mr. Pfeifer proposed a walk in the park. Hildegard pleaded a headache, and wished to be excused.

"Nonsense, child," said Pfeifer, with his usual good-humored peremptoriness. "If you have a headache, so much the more ought you to go. Put on your things now, and don't keep us waiting any longer than you can help."

Hildegard submitted with demure listlessness, and soon re-appeared in her walking costume.

The daylight had faded, and the evening was in its softest, most ethereal mood. The moon was drifting lazily among the light summer clouds, gazing down upon the many-voiced tumult of the crowded city, with that calm philosophic abstraction which always characterizes the moon, as if she, up there in her airy heights, were so infinitely exalted above all the distracting problems and doubts that harass our poor human existence. We had entered the park, which was now filled with gayly dressed pleasure-seekers; somewhere under the green roof of the trees an orchestra was discoursing strains of German music to a delighted Teutonic audience.

"*Donnerwetter!*" said Pfeifer, enthusiastically; "that is the symphony in *E flat*; pretty well rendered too. Only hear that"—and he began to whistle the air softly, with lively gesticulations. "Come, let us go nearer and listen."

"No, let us stay here, uncle," remonstrated Hildegard. "I don't think it is quite nice to go so near. They are drinking beer there, and there are so many horrible people."

"Nonsense, child! Where did you get all those silly whims from? Where it is respectable for your uncle to go, I am sure it wont hurt you to follow."

We made our way through the throng, and stationed ourselves under a tree, from which we had a full survey of the merry company, seated at small tables, with huge

foam-crowned mugs of beer before them. Suddenly a voice, somewhat louder than the rest, disentangled itself from the vague, inarticulate buzz, which filled the air about us. Swift as a flash my eyes darted in the direction from which the voice came. There, within a few dozen steps from us, sat Dannevig between two gaudily attired women; another man was seated at the opposite side of the table, and between them stood a couple of bottles and several half-filled glasses. The sight was by no means new to me, and still, in that moment, it filled me with strange, unspeakable disgust. The knight of Dannebrog was as charmingly free-and-easy, as if he were nestled securely in the privacy of his own fireside; his fine plumes were deplorably ruffled, his hat thrust back, and his hair hanging in tangled locks down over his forehead; his eyes were heavy, and a smile of maudlin happiness played about his mouth.

"Now, don't make yourself precious, my dear," he was saying, laying his arm affectionately around the waist of the woman on his right. "I like German kisses. I speak from experience. Angels have no business to be —"

"*Himmel*, what is the matter with the child," cried Pfeifer, in a voice of alarm. "Why, my dear, you tremble all over. I ought not to have made you go out with that headache. Wait here while I run for some water."

Before I could offer my services, he was gone, leaving me alone with Hildegard.

"Let us go," she whispered, with a long, shuddering sigh, turning a white face, full of fright, disgust, and pitiful appeal toward me.

"Shall we not wait for your uncle?" I asked.

"Oh, I cannot. Let us go," she repeated, seizing my arm, and clinging convulsively to me.

We walked slowly away, and were soon overtaken by Mr. Pfeifer.

"How do you feel now, child?" he inquired, anxiously.

"Oh, I feel—I feel—unclean," she whispered and shuddered again.

VIII.

Two years passed, during which I completely lost sight of Dannevig. I learned that he had been dismissed from the service of the Immigration Company; that he played second violin for a few

months at one of the lowest city theaters, and finally made a bold stroke for fame by obtaining the Democratic nomination for County Clerk. I was faithless enough, however, to call attention to the fact that he had never been naturalized, whereupon, a new caucus was called, and another candidate was put into the field.

The Pfeifers I continued to see frequently, and, at last, at Hildegard's own suggestion, told her the story I had so long withheld from her. She showed very little emotion, but sat pale and still with her hands folded in her lap, gazing gravely at me. When I had finished, she arose, walked the length of the room, then returned, and stopped in front of me.

"Human life seems at times a very flimsy affair, doesn't it?" she said, appealing to me again with her direct gaze.

"Yes, if one takes a cynical view of it," I answered.

She stood for a while pondering.

"Did I ever know that man?" she asked, looking up abruptly.

"You know best."

"Then it must have been very, very long ago."

A slight shiver ran through her frame. She shook my hand silently, and left the room.

One evening in the summer of 1870, just as the news from the Franco-Prussian war was arousing the enthusiasm of our Teutonic fellow-citizens, I was sauntering leisurely homeward, pondering with much satisfaction on the course history was taking. About half a mile from the Clark street bridge I found my progress checked by a crowd of men who had gathered on the sidewalk outside of a German saloon, and were evidently discussing some exciting topic. My journalistic instincts prompted me to stop and listen to the discussion.

"Poor fellow, I guess he is done for," some one was saying. "But, they were both drunk; you couldn't expect anything else."

"Is any one hurt?" I asked, addressing my next neighbor in the crowd.

"Yes. It was a poor fool of a Dane. He got into a row with somebody about the war. Said he would undertake to whip ten Deutchers single-handed; that he had done so many a time in the Schleswig-Holstein war. Then there was some fighting, and he was shot."

I spoke a few words to the policeman at the door, and was admitted. The saloon

was empty, but in the billiard-room at its rear I saw a doctor in his shirt-sleeves, bending over a man who lay outstretched on a billiard-table. A bar-tender was standing by with a basin of water and a bloody towel.

"Do you know his name?" I inquired of the police officer.

"They used to call him Danish Bill," he answered. "Have known him for a good while. Believe his real name was Danborg, or Dan—something."

"Not Dannevig?" I cried.

"Dannevig? Yes, I guess you have got it."

I hastily approached the table. There lay Dannevig—but I would rather not describe him. It was hard to believe it, but this heavy-lidded, coarse-skinned, red-veined countenance bore a cruel, caricatured resemblance to the clean-cut, exquisitely modeled face of the man I had once called my friend. A death-like stupor rested upon his features; his eyes were closed, but his mouth half open.

"By Jove!" exclaimed the physician, in a burst of professional enthusiasm, "what a splendid animal he must have been! Hardly saw a better made man in all my life."

"But he is not dead!" I protested, somewhat anxiously.

"No; but he has no chance, that I can see. May last over to-morrow, but hardly longer. Does any one know where he lodges?"

No one answered.

"But, *Himmel!* he cannot shtay here!" The voice was the bar-tender's, but it seemed to be addressed to no one in particular.

"I have known him for years," I said. "Take him to my rooms; they are only a dozen blocks away."

A carriage was sent for, and away we drove, the doctor and I, slowly, cautiously, holding the still unconscious man between us. We laid him on my bed, and the doctor departed, promising to return before morning.

A little after midnight Dannevig became restless, and as I went to his side, opened his eyes, with a look of full, startled consciousness.

"I'm about played out, old fellow, aint I?" he groaned.

I motioned to him to be silent.

"No," he went on, in a strained whisper, "it is no use now. I know well enough how I stand. You needn't try to fool me."

He lay for a while motionless, while his

eyes wandered restlessly about the room. He made an effort to speak, but his words were inaudible. I stooped over him, laying my ear to his mouth.

"Can—can you lend me five dollars?"

I nodded.

"You will find—a pawnbroker's check—in my vest pocket," he continued. "The address is—is—on it. Redeem it. It is a ring. Send it—to—to the Countess von Brehm—with—with—my compliments," he finished with a groan.

We spent several hours in silence. About three o'clock the doctor paid a brief visit; and I read in his face that the end was near. The first sunbeams stole through the closed shutters and scattered little quivering fragments of light upon the carpet. A deep stillness reigned about us. As I sat watch-

ing the defaced ruin of what had been, to me at least, one of the noblest forms which a human spirit ever inhabited, the past moved in a vivid retrospect before my eye, and many strange reflections thronged upon me. Presently Dannevig called me and I stood again bowing over him.

"When you—bury me," he said in a broken whisper. "Carry my—cross of—Dannebrog—on a cushion after me." And again after a moment's pause: "I have—made a—nice mess of it, haven't I? I—I—think it would—have—have been better for—me, if—I had been—somebody else."

Within an hour he was dead. Myself and two policemen followed him to the grave; and the cross of Dannebrog, with a much soiled red ribbon, was carried on a velvet cushion after his coffin.

NOTES OF A WALKER.

I.

A NEW NOTE IN THE WOODS.

THERE is always a new page to be turned in natural history if one is sufficiently on the alert. I did not know that the eagle celebrated his nuptials in the air till one early spring day I saw a pair of them fall from the sky with talons hooked together. They dropped a hundred feet or more, in a wild embrace, their great wings fanning the air, then separated and mounted aloft, tracing their great circles against the clouds. "Watch and wait" is the naturalist's sign. For years I have been trying to ascertain for a certainty the author of that fine plaintive piping, to be heard more or less frequently, according to the weather, in our summer and autumn woods. It is a note that much resembles that of our small marsh frogs in spring—the *hylodes*; it is not quite so clear and assured, but otherwise much the same. Of a very warm October day I have heard the wood vocal with it; it seemed to proceed from every stump and tree about one. Ordinarily, it is heard only at intervals throughout the woods. Approach never so cautiously the spot from which the sound proceeds, and it instantly ceases, and you may watch for an hour without again hearing it. Is it a frog, I said, the small tree-frog, the piper of the marshes repeating his

spring note but little changed amid the trees? Doubtless it is, yet I must see him in the very act. So I watched and waited, but to no purpose, till one day, while bee-hunting in the woods, I heard the sound proceed from beneath the leaves at my feet. Keeping entirely quiet, the little musician presently emerged, and lifting himself up on a small stick, his throat palpitated and the plaintive note again came forth. "The queerest frog ever I saw," said a youth who accompanied me, and whom I had enlisted to help solve the mystery. No; it was no frog or toad at all, but the small, red salamander, commonly called lizzard. The color is not strictly red, but a dull orange, variegated with minute specks or spots. This was the mysterious piper, then, heard from May till November through all our woods, sometimes on trees, but usually on or near the ground. It makes more music in the woods in autumn than any bird. It is a pretty, inoffensive creature, walks as awkwardly as a baby, and may often be found beneath stones and old logs in the woods, where, buried in the mold, it passes the winter. (I suspect there is a species of little frog—*Pickering's hylodes*—that also pipes occasionally in the woods.) I have discovered also that we have a musical spider. One sunny April day, while seated on the borders of the woods my attention was attracted by a soft uncertain purring sound that proceeded from

the dry leaves at my feet. On investigating the matter, I found that it was made by a busy little spider. Several of them were traveling about over the leaves as if in quest of some lost cue or secret. Every moment or two they would pause, and by some invisible means make the low purring sound referred to. Mr. J. C. Allen says the common turtle or land tortoise also has a note,—a loud, shrill, piping sound. It may yet be discovered that there is no silent creature in nature.

II.

THE SAND HORNET.

I TURNED another (to me) new page in natural history, when, during the past season, I made the acquaintance of the sand wasp or hornet. From boyhood I had known the black hornet, with his large paper nest, and the spiteful yellow-jacket; with his lesser domicile, and had cherished proper contempt for the various indolent wasps. But the sand hornet was a new bird, in fact, the harpy eagle among insects, and he made an impression. While walking along the road about mid-summer, I noticed working in the tow-path, where the ground was rather inclined to be dry and sandy, a large yellow hornet-like insect. It made a hole the size of one's little finger in the hard, gravelly path beside the road-bed. When disturbed, it alighted on the dirt and sand in the middle of the road. I had noticed in my walks some small bullet-like holes in the field that had piqued my curiosity, and I determined to keep an eye on these insects of the road-side. I explored their holes, and found them quite shallow, and no mystery at the bottom of them. One morning in the latter part of July, walking that way, I was quickly attracted by the sight of a row of little mounds of fine freshly dug earth resting upon the grass beside the road, a foot or more beneath the path. "What is this?" I said. "Mice, or squirrels, or snakes," said my neighbor. But I connected it at once with the strange insect I had seen. Neither mice nor squirrels work like that, and snakes do not dig. Above each mound of earth was a hole the size of one's largest finger, leading into the bank. While speculating about the phenomenon, I saw one of the large yellow hornets I had observed, quickly enter one of the holes. That settled the query. While spade and hoe were being brought to dig him out, another hornet

appeared, heavy-laden with some prey, and flew humming up and down and around the place where I was standing. I withdrew a little, when he quickly alighted upon one of the mounds of earth, and I saw him carrying into his den no less an insect than the cicada or harvest fly. Then another came, and after coursing up and down a few times, disturbed by my presence, alighted upon a tree, with his quarry, to rest. The black hornet will capture a fly, or a small butterfly and after breaking and dismembering it, will take it to his nest; but here was this hornet carrying an insect much larger than himself, and flying with ease and swiftness. It was as if a hawk should carry a hen, or an eagle a turkey. I at once proceeded to dig for one of the hornets, and after following his hole about three feet under the foot-path and to the edge of the road-bed, succeeded in capturing him, and recovering the cicada. The hornet weighed fifteen grains, and the cicada nineteen, but in bulk the cicada exceeded the hornet by more than half. In color the wings and thorax, or waist, of the hornet, were a rich bronze; the abdomen was black, with three irregular yellow bands; the legs were large and powerful, especially the third, or hindmost pair, which were much larger than the others, and armed with many spurs and hooks. In digging its hole the hornet has been seen at work very early in the morning. It backed out with the loosened material like any other animal under the same circumstances, holding and scraping back the dirt with its legs. The preliminary prospecting upon the foot-path, which I had observed, seems to have been the work of the males, as it was certainly of the smaller hornets, and the object was doubtless to examine the ground, and ascertain if the place was suitable for nesting. By digging two or three inches through the hard, gravelly surface of the road, a fine sandy loam was discovered, which seemed to suit exactly, for in a few days the main shafts were all started in the greensward, evidently upon the strength of the favorable report which the surveyors had made. These were dug by the larger hornets or females. But one bee inhabited each hole, and the holes were two to three feet apart. One that we examined had nine chambers or galleries at the end of it, in each of which were two locusts, or eighteen in all. The locusts of the locality had suffered great slaughter. Some of them in the hole or den had been eaten to a mere shell by the larvæ of the bee. Under the wing of

each insect an egg is attached; the egg soon hatches, and the grub at once proceeds to devour the food its thoughtful parent has provided. As it grows it weaves itself a sort of shell or cocoon, into which, after a time, it undergoes its metamorphosis, and comes out, I think, a perfect bee toward the end of summer.

I understood now the meaning of that sudden cry of alarm I had so often heard proceed from the locust or cicada, followed by some object falling and rustling amid the leaves; the poor insect was doubtless in the clutches of this arch enemy. A number of locusts usually passed the night on the under side of a large limb of a mulberry tree near by; early one morning a hornet was seen to pounce suddenly upon one and drag it over on the top of the limb; a struggle ensued, but the locust was soon quieted and carried off. It is said that the hornet does not sting the insect,—for that would kill it, and it would not keep fresh for its young,—but stupefies it, or chloroforms it, or does something of the sort, so that life remains for some days.

My friend Van, who watched the hornets in my absence, saw a fierce battle one day over the right of possession of one of the dens. An angry, humming sound was heard to proceed from one of the holes; gradually it approached the surface, until the hornets emerged locked in each other's embrace, and rolled down the little embankment, where the combat was continued. Finally, one released his hold and took up his position in the mouth of his 'den (of course I should say *she* and *her*, as these were the queen bees), where she seemed to challenge her antagonist to come on. The other bee maneuvered about a while, but could not draw her enemy out of her stronghold; then she clambered up the bank and began to bite and tear off bits of grass and to loosen gravel-stones and earth, and roll them down into the mouth of the disputed passage. This caused the besieged hornet to withdraw farther into her hole, when the other came down and thrust in her head, but hesitated to enter. After more maneuvering, the aggressor withdrew, and began to bore a hole about a foot from the one she had tried to possess herself of by force.

Besides the cicada, the sand hornet captures grasshoppers and other large insects. I have never met with it before the present summer (1879), but this year I have heard of its appearance at several points along the Hudson.

III.

THE SOLITARY BEE.

If you "leave no stone unturned" in your walks through the fields, you may perchance discover the abode of another of our solitary bees. Indeed, I have often thought what a chapter of natural history might be written on "Life under a Stone," so many of our smaller creatures take refuge there,—ants, crickets, spiders, wasps, bumble-bees, the solitary bee, mice, toads, snakes, newts, etc. What do these things do in a country where there are no stones? A stone makes a good roof, a good shield; it is water-proof and fire-proof, and, until the season becomes too rigorous, frost-proof, too. The field-mouse wants no better place to nest than beneath a large, flat stone, and the bumble-bee is entirely satisfied if she can get possession of his old or abandoned quarters. I have even heard of a swarm of hive bees going under a stone that was elevated a little from the ground. After that, I did not marvel at Samson's bees going into the carcass or skeleton of the lion.

In the woods one day (it was in November), I turned over a stone that had a very strange-looking creature under it,—a species of salamander I had never before seen, the *S. fasciata*. It was five or six inches long, and was black and white in alternate bands. It looked like a creature of the night,—darkness dappled with moonlight,—and so it proved. I wrapped it up in some leaves and took it home in my pocket. By day it would barely move, and could not be stimulated or frightened into any degree of life; but at night it was alert and active. Of its habits I know little, but it is a pretty and harmless creature. Under another stone was still another species, the *S. subviolacea*, larger, of a dark plum-color, with two rows of bright yellow spots down its back. It evinced more activity than its fellow of the moon-bespattered garb. I have also found the little musical red newt under stones, and several small, dark species.

But to return to the solitary bee. When you go a-hunting of the honey-bee, and are in quest of a specimen among the asters or golden-rod in some remote field to start a line with, you shall see how much this little native bee resembles her cousin of the social hive. There appear to be several varieties, but the one I have in mind is just the size of the honey-bee, and of the same general form and color, and its manner among the

flowers is nearly the same. On close inspection, its color proves to be lighter, while the under side of its abdomen is of a rich bronze. The body is also flatter and less tapering, and the curve inclines upward, rather than downward. You perceive it would be the easiest thing in the world for the bee to sting an enemy perched upon its back. One variety, with a bright buff abdomen, is called "sweat-bee" by the laborers in the field, because it alights upon their hands and bare arms when they are sweaty,—doubtless in quest of salt. It builds its nest in little cavities in rails and posts. But the one with the bronze—or copper—bottom builds under a stone. I discovered its nest one day in this wise: I was lying upon the ground in a field, watching a line of honey-bees to the woods, when my attention was arrested by one of these native bees flying about me in a curious, inquiring way. When it returned the third time, I said, "That bee wants something of me," which proved to be the case, for I was lying upon the entrance to its nest. On my getting up, it alighted and crawled quickly home. I turned over the stone, which was less than a foot across, when the nest was partially exposed. It consisted of four cells, built in succession in a little tunnel that had been excavated in the ground. The cells, which were about three-quarters of an inch long and half as far through, were made of sections cut from the leaf of the maple—cut with the mandibles of the bee, which work precisely like shears. I have seen the bee at work cutting out these pieces. She moves through the leaf like the hand of the tailor through a piece of cloth. When the pattern is detached she rolls it up, and embracing it with her legs, flies home with it, often appearing to have a bundle disproportionately large. Each cell is made up of a dozen or more pieces; the larger ones, those that form its walls, like the walls of a paper bag, are oblong, and are turned down at one end, so as to form the bottom: not one thickness of leaf merely, but three or four thicknesses, each fragment of leaf lapping over another. When the cell is completed it is filled about two-thirds full of bee-bread—the color of that in the comb in the hive, but not so dry, and having a sourish smell. Upon this the egg is laid, and upon this the young feed when hatched. Is the paper bag now tied up? No, it is headed up; circular bits of leaves are nicely fitted into it to the number of six or seven. They are cut without pattern or compass, and yet they are all alike, and all

exactly fit. Indeed, the construction of this cell or receptacle shows great ingenuity and skill. The bee was, of course, unable to manage a single section of a leaf large enough, when rolled up to form it, and so was obliged to construct it of smaller pieces, such as she could carry, lapping them one over another.

A few days later I saw a smaller species carrying fragments of a yellow autumn leaf under a stone in a corn-field. On examining the place about sundown to see if the bee lodged there, I found her snugly ensconced in a little rude cell that adhered to the under side of the stone. There was no pollen in it, and I half suspected it was merely a berth in which to pass the night.

These bees do not live even in pairs, but absolutely alone. They have large baskets on their legs in which to carry pollen, an article they are very industrious in collecting.

Why the larger species above described should have waited till October to build its nest is a mystery to me. Perhaps the pollen of the fall flowers is indispensable; or may be this was the second brood of the season.

IV.

A WISE ARCHITECT.

I AM more than half persuaded that the muskrat is a wise little animal, and that on the subject of the weather, especially, he possesses some secret that I should be glad to know. In the fall of '78 I noticed that he built unusually high and massive nests. I noticed them in several different localities. In a shallow, sluggish pond by the roadside, which I used to pass daily in my walk, two nests were in process of construction throughout the month of November. The builders worked only at night, and I could see each day that the work had visibly advanced. When there was a slight skim of ice over the pond this was broken up about the nests, with trails through it in different directions where the material had been brought. The houses were placed a little to one side of the main channel and were constructed entirely of a species of coarse wild grass that grew all about. So far as I could see from first to last they were solid masses of grass, as if the interior cavity or nest was to be excavated afterward, as doubtless it was. As they emerged from the pond they gradually assumed the shape of a miniature mountain, very bold and steep

on the south side, and running down a long gentle grade to the surface of the water on the north. One could see that the little architect hauled all his material up this easy slope, and thrust it out boldly around the other side. Every mouthful was distinctly defined. After they were two feet or more above the water, I expected each day to see that the finishing stroke had been given and the work brought to a close. But higher yet, said the builder. December drew near, the cold became threatening, and I was apprehensive that winter would suddenly shut down upon those unfinished nests. But the wise rats knew better than I did; they had received private advices from head-quarters, that I knew not of. Finally, about the 6th of December, the nests assumed completion; the northern incline was absorbed or carried up, and each structure became a strong massive cone, three or four feet high, the largest nest of the kind I had ever seen. Does it mean a severe winter? I inquired. An old farmer said it meant "high water," and he was right once, at least, for in a few days afterward we had the heaviest rain-fall known in this section for half a century. The creeks rose to an almost unprecedented height. The sluggish pond became a seething, turbulent water-course; gradually the angry element crept up the sides of these lake dwellings, till, when the rain ceased, about four o'clock, they showed above the flood no larger than a man's hat. During the night the channel shifted till the main current swept over them, and next day not a vestige of the nests was to be seen; they had gone down-stream, as had many other dwellings of a less temporary character. The rats had built wisely, and would have been perfectly secure against any ordinary high water, but who can foresee a flood? The oldest traditions of their race did not run back to the time of such a visitation.

Nearly a week afterward another dwelling was begun, well away from the treacherous channel, but the architects did not work at it with much heart; the material was very scarce, the ice hindered, and before the basement-story was fairly finished, winter had the pond under his lock and key.

In other localities I noticed that where the nests were placed on the banks of streams, they were made secure against the floods by being built amid a small clump of bushes. The present season the muskrats are building a nest in the same pond, but they began it later and have not planned it

on so large a scale. At the present writing (December 15) it is not yet finished. This fact would seem to indicate a later and milder winter and less high water. The muskrat is not found in the Old World, which is a little singular, as other rats abound there, and as those slow-going English streams especially, with their grassy banks, are well suited to him. The water-rat of Europe is smaller, but of similar nature and habits. The muskrat does not hibernate like some rodents, but is pretty active all winter. In December I noticed in my walk where they had made excursions of a few yards to an orchard for frozen apples. One day, along a little stream, I saw a mink track amid those of the muskrat; following it up, I presently came to blood and other marks of strife upon the snow beside a stone wall. Looking in between the stones, I found the carcass of the luckless rat, with its head and neck eaten away. The mink had made a meal off him.

v.

CHEATING THE SQUIRRELS.

For the largest and finest chestnuts I had last fall I was indebted to the gray squirrels. Walking through the early October woods one day, I came upon a place where the ground was thickly strewn with very large unopened chestnut burs. On examination I found that every bur had been cut square off with about an inch of the stem adhering, and not one had been left on the tree. It was not accident, then, but design. Whose design? The squirrels'. The fruit was the finest I had ever seen in the woods, and some wise squirrel had marked it for his own. The burs were ripe, and had just begun to divide, not "threefold" but fourfold "to show the fruit within." The squirrel that had taken all this pains had evidently reasoned with himself thus: "Now, these are extremely fine chestnuts, and I want them; if I wait till the burs open on the tree the crows and jays will be sure to carry off a great many of the nuts before they fall; then, after the wind has rattled out what remain, there are the mice, the chipmunks, the red squirrels, the raccoons, the grouse, to say nothing of the boys and the pigs, to come in for their share; so I will forestall events a little; I will cut off the burs when they have matured, and a few days of this dry October weather will cause every one of them to open on the ground; I shall be

on hand in the nick of time to gather up my nuts." The squirrel, of course, had to take the chances of a prowler like myself coming along, but he had fairly stolen a march on his neighbors. As I proceeded to collect and open the burs, I was half prepared to hear an audible protest from the trees about, for I constantly fancied myself watched by shy but jealous eyes. It is an interesting inquiry how the squirrel knew the burs would open if left to lie on the ground a few days. Perhaps he did not know, but thought the experiment worth trying.

The gray squirrel is peculiarly an American product, and might serve very well as a national emblem. The Old World can beat us on rats and mice, but we are far ahead on squirrels, having five or six species to Europe's one.

VI.

A FORLORN QUEEN.

ONCE, while walking in the woods, I saw quite a large nest in the top of a pine-tree. On climbing up to it, I found that two or three years before it had been a crow's nest. The next season a red squirrel had appropriated it; he had filled up the cavity with the fine inner bark of the red cedar, and made himself a dome-shaped nest, upon the crow's foundation of coarse twigs. It is probable that the flying squirrel, or the white-footed mouse, had been the next tenants, for the finish of the interior suggested their dainty taste. But when I found it, its sole occupant was a bumble-bee—the mother or queen bee, just planting her colony. She buzzed very loud and complainingly, and stuck up her legs in protest against my rude inquisitiveness, but refused to vacate the premises. She had only one sack or cell constructed, in which she had

deposited her first egg, and beside that a large loaf of bread, probably to feed the young brood with, as they should be hatched. It looked like Boston brown bread, but I examined it, and found it to be a mass of dark-brown pollen, quite soft and pasty. In fact, it was unleavened bread, and had not been got at the baker's. A few weeks later, if no accident befell her, she had a good working colony of a dozen or more bees.

This was not an unusual incident. Our bumble-bee, so far as I have observed, invariably appropriates a mouse-nest for the site of its colony, never excavating a place in the ground, nor conveying materials for a nest, to be lined with wax, like the European species. Many other of our wild creatures take up with the leavings of their betters or strongers. Neither the skunk nor the rabbit digs his own hole, but takes up with that of a woodchuck, or else hunts out a natural den among the rocks. In England the rabbit burrows in the ground to such an extent that in places the earth is honey-combed by them, and the walker steps through the surface into their galleries. Our white-footed mouse has been known to take up his abode in a hornet's nest, furnishing the interior to suit his taste. A few of our birds also avail themselves of the work of others, as the tit-mouse, the brown creeper, the blue-bird, and the house wren. But in every case they re-furnish the tenement: the wren carries feathers into the cavity excavated by the woodpeckers, the blue-bird carries in fine straws, and the chickadee lays down a fine wool mat upon the floors. When the high-hole occupies the same cavity another year, he deepens and enlarges it; the phoebe-bird in taking up her old nest puts in a new lining; so does the robin; but cases of re-occupancy of an old nest by the last named birds are rare.

(To be continued.)

THE POLITICAL OUTLOOK.

In a few months we shall be plunged once more in the excitement of a Presidential canvass, and this time the excitement promises to be unusually great, owing to the prevailing belief that the contest will be very close, and that neither candidate will be willing to acknowledge his defeat. It is, of course, possible that Congress may in the meantime agree on some mode of counting the vote, which will make the

counting a simple process as far as Congress is concerned, or, in other words, make it easy for the majority to dispose of all doubtful or disputed returns in the way most agreeable to itself. But it is not probable that anything will be done which will make the decision of the majority morally satisfactory to the minority. As long as the two great parties are as evenly balanced as they are now, the result is likely

to turn on the vote of one or two states, and this, of course, exposes the returns from all states to greater or less suspicion, and makes the temptation to doctor them in every state very powerful. In most of the states, however, the condition of public opinion, or the arrangement of the canvassing machinery, makes it easy to overcome this suspicion, but there are probably half a dozen, if not more, in which fraud may be reasonably anticipated, if the strength of the candidates in the other states should appear to be nearly equal. Unluckily, too, these states in which fraud may be reasonably anticipated are those in which, owing to the sparseness of population, and defectiveness of railroad or other communication, it is easiest to find excuses for holding back the returns until the result elsewhere has been ascertained, and until the time for judicial or other investigation has gone by. The situation is aggravated by the fact that each party believes the other capable of fraud on any needful scale. The Democrats think the Republicans cheated them out of the Presidency in 1876. The Republicans are equally well satisfied that the Democrats did their best to cheat them out of it. There is not, on either side, the least confidence in the integrity of the chiefs of the other party, any more than in that of its underlings. Each thinks its opponents capable of any trick or intrigue in order to get or keep power. This is, of course, an unfortunate state of things, but it is, of itself, not an uncommon or alarming one. In fact, it is by no means an infrequent state of things under party government everywhere, and it is one which public opinion is pretty sure under ordinary circumstances to correct.

The circumstances, however, under which the coming presidential election is to take place are not ordinary any more than those under which the last took place. The seriousness of the blow given to the Federal machinery of government by the Southern rebellion was not made manifest until the election of 1876, and that blow struck it in its weakest point,—the one election in which the whole Union participates, and the choice of the one officer who represents the whole Union. From the close of the war until 1876, the artificial organization of the Southern States under the reconstruction acts made them perforce Republican. We call their organization artificial, in the sense that it put in power a portion of the population which, rightly or wrongly, did not represent the physical

and intellectual force of the State. Government everywhere and always tends, with a strength which no legislation not backed by a powerful standing army can resist, to pass into the hands of that part of the population, whether it be the minority or majority, which is able to command the preponderance of physical force, and this preponderance of physical force in our day means a preponderance of intellectual force, because it means capacity for discipline, organization, and persistence. Between 1865 and 1876 this tendency at the South was held in a check by a variety of agencies, which we do not need here to enumerate, and the consequence was that in 1868 and 1872 the South gave a powerful vote for Grant, and made the opposition to him seem contemptible. By 1876, this tendency had, however, carried everything before it, and threw the majority of the Southern states into the hands of those whom we may call—without expressing any opinion on the morality of their title—the natural owners.

The election which followed consequently brought forcibly to mind—more forcibly even than the secession of the South—the truth of the old saying, that the greatest danger to the government lay in the manner of choosing its chief officer. We say the election of 1876 brought this to mind more forcibly than the secession of 1861, because it is much easier to deal with a movement for setting up a rival republic than with a dispute about offices. In the one case, the malcontents openly and avowedly commit treason, and expose themselves thereby to its pains and penalties. In the other, each side maintains that it is itself the government, and the minds of the best men may be confused as to “which is king, which pretender.” In the one case, the revolt has to be, from the very nature of its aims, sectional; that is, it must find the materials for its new political organization on a determinate piece of territory. In the other, it finds its adherents in every district all over the country, and they cannot be separated from the general mass of population. In fact, the late war with the South was civil war, it is true, but civil war in its most mitigated form, because the combatants were separated by geographical lines.

The contest of 1876 was made all the more dangerous by the effect of the war in exalting the Presidential office. During the war, the President was the commander-in-chief of an enormous army, and the wielder of that somewhat ill-defined, but very potent

weapon, "the war power." For some years after the war, he acted, through the army, as a sort of Protector of the states lately in rebellion, with vague, though very great authority, which in Louisiana allowed him to organize the legislature by military force. The war, too, by the additions to the revenue which it made necessary, greatly increased the number of subordinate officers dependent on his pleasure for their places, and the rapid growth of population and of the inhabited area of soil, still further increased it. During General Grant's eight years, the idea, which had grown up during Mr. Lincoln's four, that the President was not simply the chief executive officer of the government, but the champion of the Nation against active and insidious enemies seeking its destruction, gained steadily in strength, partly owing to General Grant's own antecedents and partly to the state of things at the South, about which everybody still felt uncertain and uneasy. There probably never was a period since the adoption of the Constitution in which there was greater need of the play of free criticism of the government, either from an honest or intelligent opposition, or from its own friends, than during the eight years of General Grant's administration, when so many new problems had to be solved, so many new situations dealt with, and so many mischievous relics of the war had to be swept away. But it was exempted from all such criticisms in an extraordinary degree. The memories of the war were still very fresh, and there was great reluctance felt in the Republican party to comment ungenerously on the conduct of an officer who had rendered such signal service to the country, or to appear to embarrass him in the work of keeping the "ex-rebels" in order. The opposition was disqualified for the task by its persistent hostility to the war and its ill-concealed sympathy with the secessionists. In fact the new stage in the history of the Republic was entered upon, in circumstances very similar to those which would have attended the foundation of the government, if the Tories of the Revolution, instead of flying from the country, or hiding their heads in shame, had remained and formed a powerful party in Congress and in the states to work against the new order of things, and if the framers of the Constitution instead of trying to satisfy every shade of opinion, and to disarm every order of prejudice both by their work and their explanation of it, had been largely occupied with

confounding the enemies of the Republic and keeping them out of power. Washington elected and kept in office as a menace and defense against British partisans would have been a very different President in spite of himself from the austere statesman who wrote the Farewell Address, and who though he was the object of a good deal of abuse, was a popular hero from one end of the Union to the other, and among all classes and conditions of people.

The problem was still further complicated by the means resorted to to secure the newly emancipated negroes against hostile state legislation. The suffrage was not exactly bestowed on them by Congress, but every state was forbidden to make any electoral discrimination in the distribution of the franchise on the ground of color or previous condition of servitude, and the exaction of any qualification whatever for the suffrage was discountenanced by providing that the state exacting it should suffer a loss of representatives in proportion to the number of voters which such qualification disfranchised. It was supposed that in this way not only would the negroes be enabled to protect themselves against the whites, but they would form a constituency at the South devoted to the United States government and faithful to the party which liberated them. The substantial failure of this plan, the reduction of the negroes all over the South to a condition of political inferiority, and the loss of several states in the election of 1874, giving the Democrats the majority in the following House of Representatives, combined to make the Republicans very nervous and anxious by 1876, and impelled them to cling to the Presidency with increasing tenacity. The more importance they attached to it, however, and the more use they seemed disposed to make of it, the more eagerly the Democrats desired to get hold of it; and the result was that both parties, as all the world now knows, entered on the count of the votes in the fall of that year in a thoroughly unscrupulous spirit. Of the scandals which followed we do not need to speak. Civil war was avoided by a device which, though it put an end to strife, did not satisfy the defeated party, therefore did not establish a useful precedent. The worst of it was that it left both sides in what may be called a revolutionary state of mind.

By a revolutionary state of mind, we mean a state of mind in which the voters or party managers are so eager to get possession of

power that they do not care what their opponents think of the means which they employ for that purpose, as distinguished from the constitutional state of mind, which prevents a party from taking power by any process which its opponents do not consider fair play. This revolutionary state, which has undoubtedly shown itself in both parties since 1876, is something which no thinking man can contemplate without uneasiness, or can fail to see the necessity of extirpating, at almost any cost. As long as it lasts, free government is in constant danger, not of sudden overthrow, but of insidious dry rot. It has already produced, in the Republican party, a certain amount of longing for escape from the dull and uncertain processes of persuasion and education, on which it relied for success in its beginnings, through the short cut of reliance on one man's individual character, or judgment, or even personal boldness. This is what the "strong man cry," as it is called, to-day means. It is a short expression of this sort of idea: "Our opponents are corrupt, unreasonable, wicked, and will destroy the government if they can get hold of it. Arguing with them is useless. We shall very likely have to fight them again, in defense of everything we most value, though, in the meantime, we must go through the form of contending with them at polls. Let us, therefore, propose some candidate in whom we have confidence for this crisis—some man on whose firmness and audacity we can rely, and who, when the other side try to cheat him out of the Presidency, as they probably may, will see that he gets the place, peaceably if he can, forcibly if he must." This is not, of course, Cæsarism, by any means; but it is the mental condition which has always and everywhere preceded Cæsarism. It is the cry of weary, heavy-laden men, who are willing, not to sacrifice liberty exactly, but to get rid of the strife and turmoil which attends the maintenance of liberty through constitutional processes for the sake of a more quiet life; but it is one which in every free state ought to be promptly stifled the minute it is heard.

No enumeration of the causes of the excitement which attended the last Presidential election and is likely to attend the coming one is complete without mention of the great length of time under which a party once in possession of power is, under our constitution, able to retain it. Experience seems to show that it takes from fifteen to twenty years to oust a party in power from

the Senate, the House, and the Presidency. When it is borne in mind that a change of parties means a redistribution of offices on a scale never before witnessed without a revolution, it is not surprising that a party in the United States which has been eighteen years in power, as the Republican party has, and has fought out successfully a great war, should have come to look on itself as substantially the government itself, and should look on attempts to overthrow it very much as Frenchmen look on attempts to change the form of the government. The Democrats, for these very reasons, seek the Presidency with the eagerness of men who seek a revolution, and the Republicans resist it in the spirit of men who dread a revolution. The Democrats seek the enjoyments of an amount of patronage, and the handling of an amount of money, which in other constitutional countries nothing but a revolution could give, and the Republicans hold on to an amount of patronage and the handling of an amount of money which in other constitutional countries nothing but a revolution could take away. No state in our time, with the population and revenue of the United States, would dare to throw all the administrative offices of the government into the arena to be struggled for at every election, for no political machinery as yet invented besides our own is considered able to bear such a strain. The strain is increased, too, by the periodicity of the struggle—that is by the fact that it recurs at certain fixed and frequent intervals,—so that the large and growing body of persons who seek government employment for themselves and their friends are kept in a state of constant expectation of it, and preparation for it. The effect of this on their mind and character alone, apart from its effects on legislation, is very much like that of a great public lottery. The fierceness and bitterness which this state of expectation and preparation gives to the Presidential campaign, must be added to the causes of the prodigious momentum with which each party now enters on the Presidential struggle.

What is the remedy for all this? A complete remedy no one can supply, but some suggestions toward a remedy may be offered without too much assumption. We have got to a stage in the new period of national politics in which one party or the other must take a forward step, and everybody to whom politics is a serious business, and not merely a machine for the redistribution of offices at stated intervals,

is interested in the highest degree both in compelling that step and in deciding in which direction it shall be taken. The duty of taking it rests as much on one side as on the other. It is true that the party in power only can take the initiative in all matters of legislation, but the duty of the opposition is something more than criticism. It is bound, whenever it objects, to say what it would, if it could, do instead of the thing it objects to. It is bound to give the country some better reason for putting it in possession of the government than the bad management of those who actually hold the government. A capacity for judging by no means argues a capacity for doing; and political criticism differs from literary or artistic criticism, in that the critic is bound to describe the kind of work he would produce in place of what he condemns, if the opportunity were afforded him; and not only this, but offer to produce it. It is only by taking this position that any opposition can make itself respectable, or play any useful part in politics, or earn any title to public confidence. It cannot rely simply on the failures and short-comings of the other side. It must have a programme, and submit it frequently for popular approval.

The same thing is true, *mutatis mutandis*, of the party in power. It cannot rely on the assertion that it is more patriotic, or more moral, or more religious, or more upright in any way than those who seek to supplant it. It is only a very small part of the duty of men in office to set an example of virtue in handling money or dispensing justice. Nor is a party, like a church, a depository of settled doctrines or a cultivator of private morals. It is an organization for the transaction of business. Its function, when in power, is not simply to prevent murder and robbery, and collect the revenue honestly, but to make incessant improvements, both in legislation and administration, so as not only to increase their efficiency, but to adapt them to the ever changing needs and conditions of a progressive society. No party can in our time, therefore, justify its retention of power by the simple plea that something very unpleasant would happen if it went out of office, owing to the moral inferiority of those who would probably take its place. The Turkish government is now the only one in the Western world which gives this as its *raison d'être*.

Democrats and Republicans have successfully protected themselves for ten years or more against the demand that they

should move on, by the plea that they were either getting rid of "the results of the war," or saving "the results of the war," or in some manner dealing with the results of the war. In whatever shape the plea was produced, it furnished a reason for looking back and not forward, for standing still and not marching onward. Whatever justification it may have been heretofore possible to find for this attitude, it is quite certain that all dealing with the results of the war which is possible through legislation has been exhausted. There remains not a single problem arising out of the war, except the disposition of the legal tender notes of the government, which is not now largely or wholly economical in its character, and is certain to be solved, if soluble, by the ordinary movements of trade and population, and by the ordinary social agencies of a commercial civilization. The political condition of the negro has occupied much of the attention of the Republican party since the war. He undoubtedly owes the franchise to the legislation which immediately followed the war, but it is noteworthy that no legislation has been effective in securing him the free and peaceful exercise of it, because no legislation can make a poor, or ignorant, or lethargic man independent of the opinions and feelings of his stronger and more intelligent and well-to-do neighbors in the exercise of any legal rights. If they will not support the law, the law avails him little, even if it have a half million of soldiers behind it. It has been naturally hard for the Republican party which gave him the franchise to accept this fact, and it has been trying in one way or another, for fifteen years, to overcome it, both by devices of legislation, and devices of administration, but without effect. The real remedy for the evils of the negro condition has in all probability at last been found in emigration; in other words, it turns out to be the old remedy for the hardships of the laborer and small farmer, which has been in use at the north ever since the settlement of the country. For two hundred years or more, whenever the mechanic or laborer in New York or Massachusetts found his wages too low, or his employers too harsh or grasping, or his dependence on the store-keeper too grinding, he went to the West, or moved into some other state in which labor was scarcer, and the laborer was better treated. When in like manner the small farmer found his land too poor, or mortgages too usurious, or his market too

distant, he sold or abandoned his farm, and sought better luck elsewhere. In fact, the country west of the Alleghenies and the Hudson River may be said to have been peopled in this way by the unsuccessful or discontented of the states along the ocean, and in no country is the flow of population in every direction in search of better luck, still fuller and more constant. For suffering from bad legislation or for inefficient administration of justice, relief, the like of which no other country has to show, is to be found in the multiplicity of state governments, each with its political and judicial peculiarities, and offering new-comers immediate citizenship, without any of the hardships, or inconveniences even, of exile. No political arrangement ever devised provides so effective a restraint on oppressive legislation directed either against capital or against any particular kind of industry, or any particular class of labor, as this does. Every state which indulges in such legislation is sure to be punished before very long either by the withdrawal of capital or the emigration of labor, and of the efficiency of this sanction the history of the jurisprudence of every state at the North has numerous illustrations. It did not work at the South before emancipation for obvious reasons. Labor was not free, and there was only one form of investment for capital, and legislation was exclusively in the hands of the owners of it.

The most interesting question in the Southern problem since the war has been whether the negroes would attain to the degree of intelligence and enterprise necessary to enable them to resort to the great American cure for local hardship or disabilities, and following the example of free white men at the North when they do not like their condition at home, seek better luck elsewhere; or whether they would sink into barbarous indifference to their lot, or only look for amelioration in it to appeals, pauper fashion, to the Government at Washington. The emigration movement which has commenced during the past year seems to furnish a very gratifying answer to this question. The negroes are apparently both intelligent and enterprising enough to do what white men have done for generations—seek the best field for their labor and capital without regard to state lines. Those who are thrifty enough, and acute enough, as a great many of them are, to save money in spite of the extortions of the storekeeper, and the oppressions of the planter, will stay where

they are, just as white men of the same kind would do. Those who find life too hard for them in their old homes, or like roving, will seek new homes in the North-west. Those who remain behind will then get higher wages and better social and political treatment. In other words, we are witnessing the solution by a very familiar economical process of a difficulty, on which, probably, neither Constitutional Amendments nor Acts of Congress, nor any number of Republican victories at the polls, would have produced any perceptible effect. It is a curious illustration of the extent to which the negro has come to be regarded as a mere pawn in the political game, that his emigration in accordance with an economic law, the working of which has been witnessed all over the Union for a century and which has brought millions of Irish and Germans to this country, should receive the special and high sounding name of "The Exodus," and should now be made the subject of a special Congressional inquiry.

The negro question settled, there is little or nothing of the Southern problem left. The only thing, barring differences of manners and social traditions, which separated the North from the South, was the condition of the negroes. While they were slaves, the question was who should control their labor. When they were freed, and endowed with the suffrage, the question was who should control their votes. The attempt to keep the control of them at the North by the use of party machinery has failed, and if we are to judge by what is happening in Virginia and Georgia and other States, this question also is being settled by the mere course of events,—that is, by divisions among the whites, which make the negro vote worth courting. It is all but certain that, five years hence, the negroes, in every Southern State, will be divided between parties on questions in which their own status will be in no way concerned. Once this has come to pass, there is nothing to keep the South "solid" against the North in politics. It has no interests opposed to the North; its position toward the tariff is in no way different from that of the North-west; it has to depend, and will have to depend probably for a good while to come, on the North-eastern States for its capital and credit, and in some degree for its market. The old social ideal, which did so much to produce the sectional bitterness which led to the war, was cherished in the main by men

who are old, or dead, or ruined. There are very few of the generation who now have charge of the politics and business of the South, who have more than a very faint and childish recollection of the social conditions which made the Keitts, and Butlers, and Yanceys, and Masons hate the North, and wish to set up a Republic of their own. The great cloud over the Southern future to-day consists in the fact that the young men who receive a good education, or are stirred by much enterprise or ambition, will not be induced to stay there. If they once get a taste of the North, they shrink from a return to the dullness and monotony and poverty of their home life. It no longer touches their imagination, either socially or politically or commercially. In short, the social system created by slavery was the thing known in American politics as "The South." With slavery, it has utterly perished, nay, more than perished—*etiam periere ruinae*. The motives which keep the Southern whites in the Democratic party are those which keep the Northern whites in the Democratic party—no better and no worse. They would like to get control of the administration, for the same reasons that the Tildens, Pendletons, and Voorheeses at the North would like to get hold of it, because they like power and place. There is something fantastic to every mind not accustomed to devouring the fiction of political campaigns, in the notion that, if they do get hold of it, they would destroy or break it up, or, in other words, that a body of men greatly impoverished, without any materials of their own for a political future, just emerging from the jaws of ruin, would smash a machine which they now think they have a fair chance of managing in the near future, and which would give them control of the resources of a great nation, the expenditure of \$400,000,000 per annum, and the distribution of nearly 80,000 offices.

There is not much likelihood, however, that this view will be willingly accepted by either of the parties now in the field. It would be against all experience if it were. The Democrats are not likely to acknowledge that the South will shortly have no reason to fear Republican aggression, nor the Republicans to admit that the South with which they have so long contended has vanished from the arena. Parties are composed, it is true, of large bodies of voters, with certain deeply rooted ideas on broad lines of public policy, and certain traditions held with greater or less tenacity;

but their policy and views, within any given period of ten years, are determined in the main by a few leaders, who work either openly on the stump and in the press, or secretly in the committee or the caucus. It is these men who, within certain wide limits, find what are called the issues for each election. It is they who give notice of the dangers the voter has to provide against, and suggest the means by which they are to be averted. It is they, too, who in ordinary times, generally determine the order in which those questions with which the party is bound to deal, are to be taken up. But they do all this under the influence of their own training, and habits, and antecedents, and these inevitably incline them to hold on as long as possible to the subjects with which they are familiar, or on which they speak with the confidence of long experience. By the time the party has done one piece of work, they are generally too far advanced in life to turn readily to a new one, and generally not far advanced enough to yield their places graciously to younger men. The new departure in the party career has, therefore, almost invariably to be taken under the influence of strong pressure from without, caused by the action of events on public opinion, and we can recall no case where old leaders have headed it cheerfully.

The Union which has come out of the war is in many important respects a different Union from the one which the Republican party fought to save, and which the Democratic party were willing to lose sooner than fight. It is much larger and more populous; it collects a far greater revenue; it covers a far wider area; its population is much less homogeneous, in race, in religion, in social ideals, and in character; it is confronted by many more problems of great complexity, legal and social and economical; it needs a vast deal of new legislation and new organization, and a great deal of minute investigation preparatory to such legislation and organization. The province of the government, both State and Federal, needs more defining than it has yet received. The mode of taxation needs much overhauling in every State in the Union. The management of growing masses of capital by corporations needs to be regulated on some basis that will settle the question at least for another century. The problem of the relations of the Federal to the State governments needs thorough examination from the

peaceful rather than the military side, though with the aid of all the light thrown on it by the war. It needs a solution which will have, like the Constitution, the character of a compromise between conflicting ideas rather than that of a party weapon of offense. The mode of electing the President calls for careful revision without reference to the election next ensuing; and with regard to this as well as to the honest, orderly and efficient despatch of public business, the mode of appointment, the tenure and rate of payment of the large body of officers who now constitute the civil service of the national government, call imperatively for careful reorganization. Few thinking men, whose personal interests are not affected by the existing state of things in this department, and with the grave electioneering disorders which we now witness before their eyes, believe that a Republic which in twenty years will contain 80,000,000 of people, can contrive to transact its business with a body of officers who, every four years, are compelled to view the presidential election as a revolution which threatens them with the loss of their head. With regard to popular education, to prison discipline, to the administration of criminal justice, to the treatment of the poor and the insane, the United States have lost the pre-eminent position which they held forty years ago. In none of these things has the country held the lead which it had assumed in the earlier part of the century; or, in other words, in almost all branches of the work of social reformation, Europe has got ahead of us almost as much as we have got ahead of her in almost all branches of material development and mechanical contrivance.

To resume our old place, a spirit will have to be infused into politics very different from that by which the leading party men on both sides are now animated and which they strive to keep alive. To deal adequately with any of the subjects we have here enumerated, an amount of drudgery, if only in the shape of investigation and collation, would be necessary, which to nearly every prominent man on both the Republican and Democratic side would be utterly distasteful, for which his training and experience during the last twenty years have gone far to unfit him. The conflict with the South has been essentially a passionate conflict, which, except during the period of military organization for the war, has made no demand on any of our politicians for that de-

votion to detail, which in the complicated modern societies is almost the first requisite of a statesman. More than this, the very magnitude of the struggle in which they have passed so many years has given an air of insignificance and even paltriness in their eyes to the conditions on which depend the happiness and prosperity of the millions who pursue their humble and monotonous industry in the dull days of peace. But that the chiefs on either side will be forced into dealing with the really vital questions of the day by any movement which will embrace the main body of either party, is very unlikely. The main body of all parties is fond of routine in politics as in daily life, and loth to withdraw its confidence from men whom it has ever trusted or followed. The new direction to party progress is apt to come from the comparatively small force who are not so easily led, and on whom the bonds of party discipline sit lightly, and who obtain a hearing because at certain crises in party history victory cannot be achieved at the polls without their aid. The necessity of securing their support secures place for their ideas in the party programme, at first, probably,—as in the case of the insertion of the civil service plank in the Republican platform at Cincinnati,—without any intention that they shall be acted on. But this secures attention from voters whom these ideas would never reach in any other way, and attention is followed by discussion, and discussion by the conversion of the active pushing men who are seeking their fortunes in politics, and are ready to try every or any road. These once enlisted may be trusted to do the work of propagandism. The Republican party is to-day in a position which makes the work of its diversion to new uses and enterprizes probably comparatively easy. It is composed of too good material to be ever wholly reduced to the condition of a machine, and its hold on the government is so greatly weakened, and its strength at the polls so nearly equaled by that of its opponents, that it is more open to new currents of thought than it has ever been before in its history. Its susceptibility to the action of the outlying corps, who pass by the name of Independents, was fully revealed in the last election in this state; and if they cease to bring their influence to bear, by some sort of organized effort, they will neglect what seems to be a great opportunity to turn American politics into new and more promising channels.

TOPICS OF THE TIME.

A Word on Politics.

As both political parties have at various times declared themselves in favor of a reform in the Civil Service, we shall not be accused of dabbling in party politics by an allusion to the subject. It is true that neither party has shown itself to be in thorough earnest. The men on both sides who run the political machine are very much averse to this reform. They talk in their organs very contemptuously about "doctrinaires" and "impracticable schemes," and about the application to democratic institutions of a rule of action transplanted from the monarchical and aristocratic government of Great Britain!

Those who have read the President's Annual Message, and have carefully considered his somewhat elaborate treatment of this subject, will hardly find anything new or impressive in what we may offer here; but Presidents' messages are read so little, or so carelessly, that the bread may well be broken to the multitude by other hands. The subject is an easy one to argue. There is no man living who, before an audience of intelligent and non-partisan persons, can justify the old mode of political appointment to office. Every consideration is against it. The rewarding of party service by the gift of office is, in the first place, a direct corruption of morals in all concerned. It is the patent substitution of a base motive in political work for a patriotic one; and wherever and in whatever measure it prevails, it degrades politics and debases character, so that the very process of earning office by party work unfits for the public service with which it seeks to be rewarded. In any fair man's mind, the fact that a man has done some powerful politician's dirty work for the sake of getting an office which has been promised him, would be enough to condemn him as most unfit to hold any office in the gift of the government.

Opposition to Civil Service reform comes only from party politicians who have dirty work to do,—and by dirty work we mean simply the work which they are ashamed to do for themselves. How to pay for this work without taking the money out of their own pockets, is the question. If there were some other way besides the bestowal of public office, they would take the people's side of this matter, and we should have the reform fully and at once. But, in truth, they see no way of getting their own work done except by paying office for it. So they are opposed to the reform, and throw all possible obstacles in its way. In this they are aided, of course, by all their whipper-snappers up and down the land. Let it be understood that the advocates of reform simply ask that the government shall have the advantage of the same rules of business that are practiced and enjoyed by a private man or a corporation. No business concern would prosper, or be considered safe for a day, whose affairs were carried on by

a set of officials and operatives who had received their places, not because of any fitness for their work, but from corrupt considerations of favoritism. The fact that reform is entirely practicable is demonstrated by the history of the same reform in Great Britain, where office was formerly bestowed both as a reward of party service and as the gift of personal favoritism. The reform met the same opposition there that it is meeting here; but it is complete, and all are not only satisfied but delighted with it.

It should be remembered, also, in the consideration of this subject, that the effect of "the machine" is not only disastrous to the efficiency of the public business, but that it reacts mischievously upon the political life of the country. If there were no such thing as "the spoils of office," a very different set of men would naturally find themselves in possession of the political machinery. It is the base men—the men who are open to mercenary considerations, the men who are after rewards of various sorts, and who are working in the private interest of others as well as themselves—who control the primaries, and drive from influence those who cannot become yoke-fellows with political understrappers and gamblers. The great masses of the people are honest, and desire to deal honestly with political affairs; but they have not at all the machinery of politics in their hands, and they are led by a set of political tricksters into campaigns the bottom motives of which are utterly base and shameful. Take the last political campaign in New York. The Democratic party was divided on the question simply as to who should control it. It was a fight as to what set of personal influences should have the precedence. The Republican party ran a ticket nominated by the machine,—a ticket notoriously unpopular, every influence of which would be delivered against Civil Service reform,—set up and approved by the arch opponent of that reform. That an administration fully committed to this reform should be compelled, for the sake of consolidating its party and keeping it in harmony for its next year's work, to labor for the success of this ticket was the most disgusting and humiliating dish of political crow that any administration was ever called upon to eat. Voting, in these last years, has become simply a choice of evils. Men have party preferences, and desire to see their party succeed. They find themselves hampered, however, by the machine, with never a good ticket; and in their votes they nominally approve of men and methods which are offensive or unsatisfactory to them. So true is this, that Mr. Everts will be obliged to look among the "scratchers," whom he taunted with "voting in the air," for the indorsement of that part of the message of his chief which is devoted to the matter of Civil Service reform.

Congress can do no better work than in keeping alive, by a generous and just appropriation, the Civil

Service Commission, established several years ago. It seems that, notwithstanding the practical suspension of the presiding Commission, examinations have been kept up at various points, and especially in New York, with the very happiest results. We say Congress can do no better work than this, for it is in the line of political purity and departmental efficiency. The obstructionists can have no hope that this reform is going backward. They may find a Grant who will grow lukewarm in their favor, or a Conkling to cook crow for his own party, but these will prove to be only temporary advantages. The reform is based upon right. It is on the side of a sound business policy in public administration. It has the good will of all good and unselfish men. It is only opposed by base men,—by selfish men, who have something to make out of the bestowal of office as a political or personal favor. The people believe in it, and the people will have it,—if not by this Congress and this administration, then by others,—sometime and soon.

Temperance Education.

By the vote of our city Board of Education, on the sixth of November last, the English school-book, prepared by Benjamin Ward Richardson, called "The Temperance Lesson-Book," was adopted among the text-books which our city teachers are at liberty to use. We hope there are a good many teachers in the city who are willing to take up this book and teach it to their classes, for there is no doubt that boys go out into the dangers of the world lamentably ignorant of those that await them among the drinking-shops. We are sorry that this instruction must come into the schools through special text-books, though it is better that it come in this way than not at all. It must come, at last, into all competent schools, but when that point shall be reached, it will come in books on physiology and political economy, in a natural and perfectly legitimate way. A special text-book on temperance may be well enough in the absence of the general books, in which the topic has its appropriate place and space; but it is like a text-book on opium-eating. In short, the incompetence of the books on physiology and political economy has forced the friends of temperance into the use of this make-shift, which is surely a great deal better than nothing.

There is, probably, no hallucination so obstinate as that which attributes to alcoholic drink a certain virtue which it never possessed. After all the influence of the pulpit and the press, after all the warning examples of drunkenness and consequent destruction, after all the testimony of science and experience, there lingers in the average mind an impression that there is something good in alcohol, even for the healthy man. Boys and young men do not shun the wine-cup as a poisoner of blood and thought, and the most dangerous drug that they can possibly handle; but they have an idea that the temperance man is a fogy or a foe to a free social life, whose practices are ascetic, and whose warnings are to be laughed at and disregarded. Now, in alcohol, in its various forms,

we have a foe to the human race so subtle and so powerful, that it destroys human beings by the million, vitiates all the mental processes of those who indulge in it, degrades morals, induces pauperism and crime in the superlative degree when compared with all other causes, corrupts the homes of millions and makes hells of them, and wastes the national resources more certainly and severely than war; yet so little have the writers upon physiology and political economy regarded this vital and economical factor in human affairs, that the friends of temperance have been obliged to get up and push a special text-book upon it! Verily, they must be a brilliant set of men! Hereafter no text-book on either physiology or political economy should be adopted in any school in the country that does not competently treat of the alcohol question.

It is a cruel thing to send a boy out into the world untaught that alcohol in any form is fire and will certainly burn him if he puts it into his stomach. It is a cruel thing to educate a boy in such a way that he has no adequate idea of the dangers that beset his path. It is a mean thing to send a boy out to take his place in society, without understanding the relations of temperance to his own safety and prosperity, and to the safety and prosperity of society. Of course, the great barrier between the youth and correct knowledge,—the great mystifier and misleader,—is respectable society. This is practically saying to the young, pretty universally, that wine is a good thing. Fine dinners are never given without it, and good men and women drink it daily. They do not get drunk, they may be conscientious and religious, and many of them not only do not regard wine-drinking as harmful, but as positively beneficial. The boy and the young man see all this, and think, naturally, that those who have experience in drink should know better about its results than those who let drink alone.

Now, what we want to do in our schools is to do away with the force of a pernicious example, and a long-cherished error, by making the children thoroughly intelligent on this subject of alcohol. They should be taught the natural effect of alcohol upon the processes of animal life. (1st) They should be taught that it can add nothing whatever to the vital forces or to the vital tissues,—that it never enters into the elements of structure, and that, in the healthy organism, it is always a burden or a disturbing force. (2d) They should be taught that it invariably disturbs the operation of the brain, and that the mind can get nothing from alcohol of help that is to be relied upon. (3d) They should be taught that alcohol inflames the baser passions, blunts the sensibilities, and debases the feelings. (4th) They should be taught that an appetite for drink is certainly developed by those who use it, which is dangerous to life, destructive of health of body and peace of mind, and in millions of instances ruinous to fortune and to all the high interests of the soul. (5th) They should be taught that the crime and pauperism of society flow as naturally from alcohol as any effect whatever naturally flows from its competent cause. (6th) They should be

taught that drink is the responsible cause of most of the poverty and want of the world. So long as six hundred million dollars are annually spent for drink in this country, every ounce of which was made by the destruction of bread, and not one ounce of which has ever entered into the sum of national wealth, having nothing to show for its cost but diseased stomachs, degraded homes, destroyed industry, increased pauperism, and aggravated crime, these boys should understand the facts and be able to act upon them in their first responsible conduct.

The national wealth goes into the ground. If we could only manage to bury it without having it pass thitherward in the form of a poisonous fluid through the inflamed bodies of our neighbors and friends, happy should we be. But this great, abominable curse dominates the world. The tramp reminds us of it as he begs for a night's lodging. The widow and the fatherless tell us of it as they ask for bread. It scowls upon us from the hovels and haunts of the poor everywhere. Even the clean, hard-working man of prosperity cannot enjoy his earnings because the world is full of misery from drink. The more thoroughly we can instruct the young concerning this dominating evil of our time, the better will it be for them and for the world. Let us use the "temperance lesson-book" wherever we may. Let parents demand that it shall be used, and particularly let all writers upon physiology and political economy for schools take up the subject of alcohol, and treat it so candidly, fully, and ably that their books shall no longer be commentaries on their own incompetency to fill the places whose functions they have assumed.

Familiarity.

OF all the sources of bad manners, we know of none so prolific and pernicious as the license of familiarity. There is no one among our readers, we presume, who has not known a village or a neighborhood in which all the people called one another by their first or Christian names. The "Jim," or "Charley," or "Mollie," or "Fanny," of the young days of school-life, remain the same until they totter into the grave from old age. Now, there may be a certain amount of good-fellowship and homely friendliness in this kind of familiar address, but there is not a particle of politeness in it. It is all very well, within a family or a circle of relatives, but when it is carried outside, it is intolerable. The courtesies of life are carried on at arm's length, and not in a familiar embrace. Every gentleman has a right to the title, at least, of "Mister," and every lady to that of "Miss" or "Mistress," even when the Christian name is used. For an ordinary friend to address a married woman as "Dolly" or "Mary," is to take with her an unpardonable liberty. It is neither courteous nor honorable; in other words, it is most unmannerly. We have known remarkable men, living for years under the blight of their familiarly-used first names,—men whose fortunes would have been made, or greatly mended, by removing to some place where they

could have been addressed with the courtesy due to their worth, and been rid forever of the cheapening processes of familiarity. How can a man lift his head under the degradation of being called "Sam" by every man, young and old, whom he may meet in the street? How can a strong character be carried when the man who bears it must bow decently to the name of "Billy?"

This is not a matter that we have taken up to sport with. We approach it and regard it with all seriousness, for this feeling and exhibition of familiarity lie at the basis of the worst manners of the American people. We are not asking, specially, for reverence for age or high position, but for manhood and womanhood. The man and woman who have arrived at their majority have a right to a courteous form of address, and he who withholds it from them, or, presuming upon the intimacies of boyhood, continues to speak to them as still boy and girl, is a boor, and practically a foe to good manners. We suppose the Friends would object to this statement, but we do not intend to embrace them in this condemnation. They look at this matter from a different stand-point, and base their practice upon certain considerations which have no recognition in the world around them. We think they are mistaken, but their courteous way of speaking the whole of the first name is very different from the familiar use of names and nicknames of which we complain. There is no use in denying that the free and general use of first names, among men and women, in towns and neighborhoods, is to the last degree vulgar. Gentlemen and ladies do not do it. It is not a habit of polite society, anywhere.

There is a picture we have often contemplated, which would impress different men in different ways, of a family now living in this city,—a picture which is, to us, very beautiful and very suggestive. A gentleman of the old school, somewhat reduced in circumstances, persists in living, so far as his manners are concerned, "like a king." Every night he and his sons, before dining, put themselves into evening dress. When dinner is announced, the old gentleman gives his arm to his venerable wife and leads her to the table. The other members of the family preserve the same manners that they would practice if they were dining out, or if friends were dining with them. At the close of the meal, the old man and his sons rise, while the mother and daughters withdraw, and then they sit down over their cups, and have a pleasant chat. Now the average American will probably laugh at this picture, as one of foolish and painful formality, but there is a very good side to it. Here is a family which insists on considering itself made up of ladies and gentlemen, among whom daily association is no license for familiarity, or the laying aside of good and constantly respectful manners toward one another. There is undoubtedly a great deal of bad manners in families, growing out of the license engendered by familiarity,—bad manners between husband and wife, and between parents and children. Parents are much to blame for permitting familiarity to go so far that they do not uniformly receive, in court-

eous forms, the respect due to them from their children as gentlemen and ladies.

Of the degrading familiarity assumed by conscious inferiors, it is hardly necessary to speak. Nothing cures such a thing as this but the snub direct, in the most pointed and hearty form in which it can be rendered.

"The man that hails you 'Tom' or 'Jack,'
And proves by thumps upon your back
How he esteems your merit,
Is such a friend that one had need
Be very much his friend, indeed,
To pardon or to bear it."

Men do pardon and bear this sort of thing altogether too much for their own peace, and the best good of the transgressors. The royal art of snubbing is not sufficiently understood and practiced by the average American gentleman and lady. Considering the credit our people have for boldness and push, they yield to the familiar touch and speech of the low manners around them altogether too tamely. Every gentleman not only owes it to himself to preserve his place and secure the courtesy that is his by right, but he owes it to society that every aggressive, bad-mannered man shall be taught his place, and be compelled to keep it.

COMMUNICATIONS.

The Restoration of St. Mark's.

EDITOR OF SCRIBNER'S MONTHLY. SIR:

Those who have been lately in Venice have been chagrined to find an ungainly structure of screened scaffoldings completely hiding that corner of the Ducal Palace which used to arch in pieces of the sea and sky, as one looks southward across the Piagetta, with an effect familiar, either through direct sight, or by photograph or picture, to all the world. I was gravely told that these scaffoldings had been there for eighteen years, and were likely to remain as long again; that nothing was being done behind them, but that the mattings and planks themselves were kept in good repair, year after year. It is a fact that the modern Italian restorers labor with extreme slowness, but their work when accomplished is none the less deadly; for, as a rule, when, after a generation or more, the screens do come down from in front of some marvel of antique art, we find that the beauty which was once there has departed forever. With regard to the Ducal Palace,—a friend of mine, who was admitted behind the scenes last summer, was shown a supporting stone which had been crushed, by the weight above it, into six pieces; and those in charge declared that the reparation was a matter of strict necessity.

Whether necessary or not in the case of the Ducal Palace, I believe that no such plea is raised in behalf of the proposed restoration of the western or main façade of St. Mark's. As I understand, this façade is itself a mere screen and is not involved in the support of the principal building. Yet, if it should prove that the structure is in danger of falling, the English memorialists hold "that it is within the power of science to devise a remedy which would restore its stability without moving a stone, or altering the present surface in the least." The effect of the contemplated restoration is not a matter of conjecture or sentiment. Workmen have been busy on the inside of the church, as well as on the north and south façades, for years past, and every spot they have touched they have everlastingly ruined.

The traveler in Europe soon finds that an old building will stand (as to its effect of beauty) almost any amount of settling down, or toppling over, or hiding by other buildings, or propping up with beams, or encrusting with dust and smoke; the one thing that it cannot stand is "restoration." From a thoroughly "restored" building the eye turns away empty, disappointed and disgusted. Nor is this merely because of the loss of association, or of the lack of the mellowness and tone imparted by time. Time, indeed, is a subtle and wonderful decorator whose handiwork is not to be lightly esteemed or ignorantly destroyed. But it is a matter of demonstration that the stone-cutters and the workers in mosaic of our times have not the same manner as the old ones; nor do they manipulate with equal skill, nor in the same artistic spirit. If the restorations of the Renaissance are out of keeping in this western façade,—whose earlier condition is fortunately preserved for us in Gentile Bellini's well-known painting in the Academy at Venice—how dangerous is it to attempt a restoration in our own time, even though the restorers do not venture upon new designs. The very improvements in our modern tools are a cause of deterioration in workmanship, for they substitute arithmetically straight for artistically irregular lines, and bring about a stiff and dazzling uniformity of design which is the death of grace and individuality and "the unexpected." The present south façade of St. Mark's, as it stands there "glittering like sugar in the sun," is no more St. Mark's as it was than a plaster cast of the Venus of Milo is the original statue.

Now that the main façade is threatened with destruction, it is to be hoped that no effort will be spared in its behalf in the way of entreaty and protest. The artists and lovers of art in Oxford, Cambridge and London, who have begun the movement, expect the co-operation of America—and are sure to receive it. If the opinion and protests of the civilized world have the desired effect upon the authorities in Venice, something more will be accomplished than this one greatly-to-be-desired consum-

mation—for the moral effect will extend, doubtless, in all directions. And never was there greater need. At this moment when interest of mankind in the artistic treasures of the world has fortunately revived, and ancient art is being studied with greater avidity and intelligence than ever,—at this very moment we are in imminent danger, through mistaken zeal or sordid speculation, of losing many of the finest examples which have ever existed. Mr. Stillman writes from Florence to the London "Times," under date of November 12th:

"The municipalities,—generally under the active direction of some fussy ignoramus whom office-holding has imbued with a sense of the necessity of doing something which will require a tablet set up to commemorate his name and régime,—finding municipal loans an easy means of getting money, generally set to work putting into presentable shape the most noteworthy object of antiquity in their jurisdiction, and prove themselves new brooms with a vengeance. In Perugia, I understand, they have utterly removed one of the finest Middle-Age stained-glass windows left this century, and still uninjured, to make place for a modern Munich monstrosity. In Florence, as we all know, they swept almost everything which was most picturesque of the old city—the old walk to San Miniato, the resource of every landscape painter who came here, replacing it by an ugly flight of stone steps and balustrade; the houses of the Ponte alle Grazie; and they have those on the Ponte Vecchio marked and contracted for removal, only, fortunately, the money has failed them. The house of Dante has been renewed in the most disgusting style, 'made to look,' they said, 'as it was when Dante saw it.' In consequence we cannot see a stone that Dante ever looked on. The marvelously picturesque vista of the Arno, with its quaint old buildings, as we saw it in the Grand Duke's day, is changed into a span-new string of quays which might be Brussels, or Rouen, or any other second-rate city which has a river; and, what is worse, after spending millions in renovating, they have not even regulated the drainage of the city. * * * At Pieve di Cadere I found last summer the quaint old fountain which used to stand in front of Titian's house relegated to some rubbish depot, and

another, which used to stand in the public place, substituted for it, to make room in turn for a statue of Titian—new and shining brass."

What Mr. Stillman says of the window in Perugia, I was told by a high authority in Florence, true of many other old Italian windows. They are not only taken down to be replaced by hideous modern ones, but the old are often hidden away and utterly lost.

R. W. G.

LONDON, Nov. 21, 1879.

P. S.—The London "Times" this morning publishes what purports to be the text of a report sent by the Italian Ministry of Public Instruction to the Minister of Foreign Affairs on the subject of St. Mark's at Venice, which report will be transmitted for information to the Italian Ambassador in London. By this it appears that the memorials to the Italian Government are not necessary, steps having been already taken to prevent the proposed restoration some time before the meetings of protest in England. This report is very interesting because we learn from it the truth of the rumor of the intention to restore the western façade, and because it contains an acknowledgment of the "many errors" committed by the restorers in other parts of the church. The Minister of Public Instruction states that when he became aware of "the danger which thus threatened the magnificent façade," he demanded that the funds for the restoration should be transferred to his own estimates and, after thus obtaining control, he caused the Commission for the Preservation of Ancient Monuments to examine into the matter, and they are still engaged in this examination.

It is not to be regretted that the protest has been made in England—and it has been made not only by artists, writers, university professors, but even by the Prime Minister in his private capacity, and (privately) by members of the royal family. Though the immediate danger already may have been averted by the taste and good sense of Italians themselves, still the discussion elicited and the profound and wide-spread feeling evinced cannot fail to do good in Italy and elsewhere.

LONDON, Nov. 27, 1879.

R. W. G.

HOME AND SOCIETY.

General Principles of Cookery. III. Roasting.

It is very common to find things that are proverbially easy to do, less well done than those of acknowledged difficulty, simply because it is taken as a foregone conclusion that no art at all is required. Yet, as Mrs. Gamp says, "There's art in sticking in a pin." And in roasting meat, although it will be a new idea to many, there is at least the art of simplicity, if I may so speak; and Brillat-Sav-

arin says: "One may become a cook, but must be born a roaster," which implies that genius is required to roast well; however, common-sense and a persevering attention to rules are not bad substitutes. It is the common practice to put a quantity of water in the pan with meat to roast, and, to make a bad thing worse, the joint is thickly dredged with flour. On asking a cook, who had thrown a handful of flour over a sirloin of beef and then poured a quart of water into the pan with it, what was the object of

such immersion, Biddy answered with an air of good-natured contempt for our ignorance:

"For the gravy, of course, ma'am! Where would I get my gravy if I didn't do that?"

Of course meat so treated comes to table sodden, juiceless, tasteless and unsightly, and accompanied by a quart—more or less—of gray, thickish broth, instead of the rich brown gravy natural to well-cooked meat.

In addition to this flour-and-water treatment, the abused joint is generally put into a lukewarm oven an hour or two before it begins to cook, where it slowly steams and oozes, until the hour for dinner; when, whether it is cooked little or much, it is served.

Roasting, then, as I have hinted, must be very simple. Little or no preparation is necessary. The only requisites are a bright fire and a hot oven; then place the joint in the pan, on an iron tripod if possible, as this keeps it out of the fat; and if it is very lean, put a table-spoonful, or two, of water—not more—into the pan; if fat, it will not require any. No flour is necessary if the meat has not been washed, and if you buy from a good butcher this will only be needed in summer if it has been kept an hour or two too long; then wash it off with vinegar, dry it carefully, and very lightly dust it with flour to absorb any moisture that may remain on the surface. While the meat is in the oven, baste it several times, and when about half done turn it—always keeping the thickest part of the meat in the hottest part of the oven.

In cooking sirloin of beef great care must be taken that the fat of the "undercut," as our English cousins call it, be quite cooked. It is not unusual to see a splendid roast come to table with the fat of the tenderloin not even warm through, and the tender meat of that favorite part absolutely purple, while the upper and less choice part is sufficiently cooked.

While the meat is in the oven the fire should be kept hot and bright; it should have been so made up as to last sufficiently long, but if the joint is very large it may require replenishing, this may be done without checking the heat of the oven by adding a little fuel from time to time instead of waiting until it requires a great deal.

If the oven has been in good condition the meat will be beautifully brown and the bottom of the pan covered with a thick glaze. Gently pour off the fat, holding the pan steadily as you do it, that the gravy may not go with it; then put the pan on the stove and pour into it half a cup of boiling water (more if the joint is very large and less if very small) and a little salt. If you have soup of any kind use it in preference to water; stir it with a spoon until the adhering glaze or gravy is entirely removed from the pan, it will dissolve as it mingles with the liquid, and make a rich brown gravy.

Before the joint is served, sift over it evenly—not in patches—fine salt. This must never be done before it is cooked as it draws out the juice of the meat.

It must be repeated that nothing so injures meat as to put it into a cold oven, allowing both to get hot together.

Some meats require longer to cook than others. Pork and veal much longer than mutton and beef. The former meats require to be very well done—the latter, most people like under-done; but even when this is the case, it should be remembered that the texture should be changed all through; the gravy is then released and runs red with the knife, while the grain of the meat is seen through it, of a bright red instead of the livid purple hue so frequently called rare, but which is simply raw.

Poultry may be either cooked with a little butter to baste it, or it may be larded or "barded"—although the latter are the modes of preparing adopted by all good European cooks. To many Americans the flavor of bacon is objectionable, yet even where it is approved, larding is often supposed to be so difficult as to require a professed cook to do it; but it is actually so simple that any lady wishing to indulge in dainty dishes will take the small trouble of learning it, to teach her inexperienced cook. Two larding needles are required—to be procured at any good house-furnishing store—one large-sized for veal, beef *à la mode*, etc.; the other, small, for poultry, cutlets, and sweetbreads. In larding poultry, hold the breast over a clear fire for a minute, or dip it in boiling water to make the flesh firm. Cut some strips of firm fat bacon, two inches long, and the eighth of an inch wide, and make four parallel marks on the breast, put one of these strips of bacon fat, called lardoons, into the split end of the small needle, securely, and insert it in the first mark, bringing it out at the second, leaving an equal length of fat protruding at each end; insert these lardoons at intervals of half an inch or less down the two lines first commenced, and then do the same with the two others.

All white-fleshed birds are improved by larding, as is veal and sweetbread. Yet small ones, quails, for instance, may have a barde—*i. e.*, a slice of bacon fat—tied round them. This may also be done with fowls, or veal, where bacon is liked and larding inconvenient.

Game requires nothing but good butter to baste it. Any sort of stuffing is ruinous to the flavor, except in the case of pigeons, where a little chopped parsley may be mixed with butter, and placed inside.

Wild duck, if fishy, and the flavor is disliked, should be scalded for a few minutes in salt and water before roasting. If the flavor is very strong the duck may be skinned, as the oil in the skin is the objectionable part. After skinning, spread with butter, and thickly dredge with flour before putting in a very quick oven.

CATHERINE OWEN.

Flour from Chestnuts.

[We are courteously permitted to transcribe the following paragraphs from a very interesting re-

port to the State Department by Mr. J. Schuyler Crosby, U. S. Consul at Florence.—E. D. S. M.]

THE common chestnut-tree is said to have been brought from Asia Minor to Sardinia, and from there it has spread over the whole of Southern Europe. It existed for centuries in Tuscany, where, at one time, nearly every hill and mountain-side was covered with its verdure. The number of trees in Tuscany and Lucca is estimated at several millions, and the nut and wood have done more to maintain the population of some of these districts than any other production. Indeed, in some places wheat flour and corn meal are entirely superseded by the chestnut flour, which is very nourishing and much cheaper as an article of food.

The result of a careful study of the subject has convinced me that this species of chestnut, when grafted upon the variety indigenous to our own country, and in many parts abundant, may become a source of much wealth and profit, especially in certain mountainous districts, where it is almost impossible to raise cereals, owing to the nature of the soil and the steepness of the mountain-sides, and where transportation is so difficult and labor so high and scarce. Outside of this question of using the chestnut for food in the districts where it could be cultivated and grown to advantage in the United States, the present price of the imported Spanish chestnut, which is used for various purposes throughout our country would, I am sure, amply repay any outlay farmers might have to make in importing rings or shoots of this magnificent variety from Italy for grafting on our own chestnut tree.

This tree grows to the height of 60 or 70 feet, and attains full maturity at the age of 60 years. Its vitality and productiveness, however, last for more than a hundred years. In many parts of Tuscany it is cultivated largely and is always raised from the seed or nut. The large variety of Spanish chestnut is cultivated from grafting on the young trees. The chestnut flourishes in a light, fertile deep soil, but thrives on the sides of mountains facing the south and west. The varieties cultivated are the following:

I. *Castagno Marone*. This is the most sought after for the largeness and exquisite taste of the nut. It thrives in fresh, damp soils and mild temperature, and for that reason is cultivated with difficulty in the higher mountains.

II. *Castagno Carpinese*, or *Carrara*. Produces high-flavored nuts in great quantities, and prospers even in cold places. The flour made from this variety is the sweetest of all, but requires great care to keep it from spoiling.

III. *Castagno Pastinese*. Thrives in cold situations. The fruit is smaller and darker, but gives a more healthy and durable flour than that of the *Carrara*.

IV. *Castagno Rossolo*. The nuts of this variety are smaller than those of the *Marone*, which they resemble in appearance or taste. The tree thrives in cold places, and grows luxuriously on the Apennines.

V. *Castagno Romagnuolo*. The nuts are enclosed

in burs, difficult to open. They are small, but high flavored, and especially good for flour. This tree is also very hardy.

VI. *Castagno Brandigliano*. This produces more fruit than any of those above mentioned, but the outside of the nut, being naturally marked with white spots, never appears to be perfectly ripe, though in reality, it is.

The chestnut is raised from the fruit, which should be planted in earth made soft by repeated working over. The plantation should be situated near a stream if possible, and the ground shaded by hedges or trees placed sufficiently near to answer that purpose. The square set aside for the cultivation of the chestnut is divided into furrows, six or seven feet wide, and in each of them holes are dug about three inches deep, and at a distance from each other of about six inches. In these holes are deposited the nuts with the germs downwards. The use of manure renders the plant more vigorous and healthy for the time, but is dangerous on account of transplanting, as the young tree finding itself on soil less rich than it has been accustomed to easily languishes and dies.

After two years the plants are transplanted to another part of the plantation, where they remain four years, after which they may be placed where they are destined to remain permanently. The season most adapted for transplanting is that after the falling of the leaves, although it may be done even as late as February or March.

For producing the fruit the tree must be grafted, which is done at the age of five or six years. There are two ways of grafting. One is the ordinary method of inserting the bud in the end of a branch, with a slit on it, where it is retained by wax or other substances. The other, which is the latest and has proved the most successful in its results, consists in cutting large rings of bark from the branches of the large or Spanish chestnut, and placing them on twigs of the ordinary kind. As this is rather a delicate operation requiring some care, a detailed description may be useful. The bark of the Spanish chestnut is cut into circles on the twigs where marks of buds appear, care being taken to have one or more buds on each circle or cylinder. This bark is then slightly beaten, to loosen it from its position, and gently twisted by hand until a hollow cylinder of bark is obtained, which is then drawn up the stem that has been previously denuded of its bark in like manner. The cylinder of bark is then carried to the stem of the tree, which is grafted. This stem, having been previously denuded of its bark and cut off down to the place where the ring is to be put on, is then covered with the ring, which unites with the growing bark and sends out shoots of the large chestnut from the grafted branches. Care must be taken to cut off all shoots of the common chestnut that may appear near the grafted part, as they interfere with the full development of the part grafted. This operation of grafting by rings is practised in Tuscany from the tenth of April to the first of May, that is, when the sap is running most freely, and just before the leaves and buds come out.

A method of preserving the grafting buds, so that they may be good even after a year, is to place them in tin tubes filled with honey, and hermetically sealed immediately on their removal from the tree. This method would seem especially adapted for transporting the Spanish chestnut to countries where it does not exist. Another manner of transporting the grafting buds is by putting them into hermetically sealed tubes filled with water. This method can only be used for transporting the buds for distances accomplished under 40 days.

The chestnut produces flowers, which, after the usual process of the male pollen being deposited on the ovaries of the female flower, become chestnuts or the seeds of the tree. This change of the flower into the nut, takes place about the end of July, and it is easy to foretell the crop of the year, by the state of the nut germs. For although the flowers may have been abundant, fecundation may not have taken place largely, and it is only by watching the tree carefully after it has flowered, that a judgment can be formed as to whether the production will be good. This appearance of young germs is called in Italian *animato*, that is living, active, animated. The ovaries that are not fecundated by the flowers, change into useless shells, but those fecundated become enclosed in burrs, containing one, two, and even three chestnuts. The nuts arrive at maturity in two months after flowering, that is to say, in October, and then fall to the ground. They are also beaten from the trees by peasants armed with long poles, but this should never be done, as it seriously injures future fruit-buds, and affects the yield of the tree for another year.

The chestnut should be pruned and trimmed every three years or at the most every four, and this, while helping the tree to bear more abundantly, produces wood for fuel and other purposes; the smaller twigs and branches, when dried, are used later as fuel in drying the nuts in the manner hereafter described. The leaves are also gathered when green and young, and pressed flat in large bundles, and are then used for putting under pots of butter, and in making a kind of cake called *necci*. The Spanish chestnut has been cultivated with more than usual care and success in the province of Lucca, owing to the laws to protect it from destruction made by the Lucchesan Republic in the eleventh century.

The only disease to which the chestnut is liable is internal decay of the trunk. Instances are known where the whole life of the tree has been carried on through the external bark, while the interior was completely destroyed. Though no cure exists for this disease, it may be arrested by burning out, by a slow fire, the whole interior of the tree, with leaves, grass, and light substances. This treatment has proved efficacious in most instances.

The chestnut is composed of starch, a glutinous

substance analogous to that of the cereals and sugar. Dr. Guerazzi in experiments narrated by him, was able to extract the sugar without altering the farinaceous or nutritious part of the nut.

After gathering,—which should be done by picking up those that have fallen, and not beating the tree—the nuts are deposited in huts, in the upper part of which deep trays are constructed, on which the chestnuts are placed to the depth of six inches. In these huts slow fires are kept up, with the use of green wood, until the nuts become hard and dry. In this condition they may be kept for years. They are, however, more generally carried to the mill, where they are ground into flour, in the same manner as corn or wheat.

From this chestnut flour various preparations are made, such as *polenta* (a kind of pudding, like our so-called hasty pudding of Indian meal) and various kind of cakes, fritters, and even a heavy kind of bread. These various ways of cooking the chestnut flour, are known under the popular names of *necci*, *pattoni*, *castagnacci*, *cialdi*, *fritelli*, etc., and the food so made is sweet and agreeable to the taste, and healthy. The country people cook the chestnuts in water, and make use of this water as a drink for chest troubles, colds and dry coughs, and in most cases it has proved very beneficial. The food made of the chestnut which is most in favor is the *polenta*, made by simply boiling the chestnut flour in water for ten or fifteen minutes, with a little salt to flavor it, taking care to keep up a constant movement of the paste, and clearing the edges of the cooking utensil, so that no part becomes burnt. It is eaten with cream, butter, ham, etc., and is most healthy and nutritious.

The food called *necci* is composed of flour formed into a cake, and is made by first mixing the flour with cold water, and then making cakes piled one upon another, and separated by chestnut leaves, pressed for the purpose and moistened by water; the whole mass is then cooked over a hot fire, and the cakes are taken off one by one, when the leaves are almost burnt. These cakes are eaten with buttermilk, cheese, Bologna sausages and meat.

The chestnut flour can be preserved sweet and in good condition for two years, in the same manner as wheat flour—but a round chest of chestnut wood is preferable, which should be kept in a fresh, dry place. The flour should be pressed into the receptacles as firmly as possible, and then covered with chestnut shells. It may then be preserved for two years, and is exceedingly agreeable to the taste, and though less nutritious, is much cheaper than wheat flour. It is certainly a fact, that in those regions where the inhabitants live almost entirely on the chestnut, they are of better appearance, more healthy, and not less strong, than those people who live on what in America is considered more wholesome and nutritious food.

CULTURE AND PROGRESS.

Harpers' Latin Dictionary.*

FEW, indeed, are the educational works that retain for a generation so wide, and in the main so deserved and unchallenged a popularity, as that accorded to Andrews' edition of Freund's Latin Lexicon. But great and many as are its excellences, it has naturally become antiquated and unsatisfactory, in view of the results that have been garnered from the whole field of Latin scholarship during the last thirty years. The discovery of, and the light furnished by, a vast number of inscriptions, the critical examination and comparison of manuscripts, the closer study of the fragments of the earliest documents of the language, the more scientific grasp of Roman history and of ancient life, the more intelligent attention to archaeology, the great advances in comparative philology, as well as the steady and concentrated study of the Latin literature itself, have all naturally modified the facts and principles on which lexicography is based.

The only serious attempt to meet, in English, the increased lexical requirements of Latin study has been made by Messrs. White and Riddle, in the successive editions of their Dictionary. But though this work—compared with Andrews', on which it is based—contains more words and fuller citations, is superior in its etymologies, and corrects many typographical errors and some errors in statement, yet the change, as a whole, is rather in quantity than in quality, and few have probably used the book without a keen sense of its coming far short of an attainable standard. The inconvenient form of its publication, too, has been a serious drawback to its use.

The editors and collaborators of Harpers' Latin Dictionary, by a thorough revision of the original work and by incorporating the best results of research in many directions, have made a substantial addition to our apparatus for exact Latin study, and it may reasonably be expected that their labors will be accepted as the standard by English-speaking students of Latin.

The book contains 2,019 three-column pages to 1,651 in Andrews', and each page is a trifle larger than that of the original. Dr. Freund's long and rather discursive preface has been omitted, as have his appendices that contained specimens of the oldest monuments of the language and French and Italian derivatives. Some of the derivatives are distributed throughout the Dictionary, and very many are dropped altogether. A synoptical table of the forms, syntax, and orthography of the language, until these were crystallized and stereotyped by the literature, perhaps hardly falls within the province of strict lexicography; but such a table is so full of instructive

interest that we should gladly have seen the original preserved in an augmented form.

In orthography, the new Dictionary satisfies a real desideratum. The spelling of classical Latin has for several years been essentially established, and the persistent retention of exploded forms in many recent texts and lexicons, whether from a timid conservatism or from an easy-going ignorance of accessible facts, has been a reproach upon Latin scholarship. Here very properly Brambach has been followed as a guide, and it is a positive gratification to miss such too-long usurping forms as *cæna*, *concio*, *conditio*, *quum*.

For the etymologies of the Dictionary free use has been made of the labors of Corsen, Curtius, Vanček, and other investigators, and he who works at the language from this side can here find more, and more reliable, information than in any other single treatise. But valuable though much of the etymological work is, it seems to us the least successful part of the Dictionary. There are imprudences, inconsistencies, and inequalities of statement that might have been avoided if this important and very delicate part had been intrusted to some trained and judicial etymologist. Good authorities certainly differ in regard to the etymologies of *calamitas*, *clarus*, *ingruo*, *populus*, *prælium*, *provincia*; but we doubt if many such will assent to those here preferred. What is said under *insula*, *servus*, *vidua*, in regard to the source of those words, is not in accord with the statements under *consul*, *salus*, *divido*. Quite full lists of derivatives and cognates in other languages are frequently presented; but, as this is a Latin-English Dictionary, why, under *caput*, *cutis*, *duco*, *frigor*, *hostis*, are not the genetic relations of *head*, *hide*, *tug*, *brook*, *guest*, given, as well as of the German *Haupt*, *Haut*, *ziehen*, *brauchen*, *Gast*? And where so much is attempted, ought not suggestive hints to have been more often given in regard to the origin of proper names, as *Cicero*, *Fabius*, *Lentulus*, *Marcus*?

In the accuracy and fullness of its definitions, the Dictionary will probably well stand the test of critical, as well as of ordinary, usage. The monographs on many of the words have been entirely reconstructed, and those of many more have been enlarged and thoroughly revised. The radical, current, figurative, and rarer meanings of words are clearly stated, with logical and chronological system, and corroborated by a rich array of citations drawn from the best seven centuries of the language. Nowhere else has the student before him so complete a historical conspectus of Latin words, with the means of its verification. As an example of the masterly critical and exhaustive treatment of individual words, we may refer to the six pages devoted to the conjunction *cum*. The etymology, forms, literal and derived meanings, and various syntactical uses of this word are stated with a fullness probably never before attempted in a Dictionary; the latest theories in regard to the somewhat puzzling modal uses of the

* Harpers' Latin Dictionary. A new Latin Dictionary, founded on the translation of Freund's Latin-German Lexicon, edited by E. A. Andrews, LL.D. Revised, enlarged, and in great part re-written, by Charlton T. Lewis, Ph.D., and Charles Short, LL.D., Professor of Latin in Columbia College. New York: Harper and Brothers. Oxford: at the Clarendon Press. 1879.

word are reviewed, and every statement made or theory suggested is supported by a wealth of illustrative citations. This very fullness of treatment may be an impediment to tyros and ordinary users of the book; but as it is the outcome of advanced and comprehensive scholarship, so it should be a stimulus thereto. Some articles, naturally enough, are meagerly treated. We should gladly have seen an ampler discussion of e. g. *ds*. One who tests the Dictionary by the Protean employment of this little word in, say, the first book of the Annals of Tacitus, will hardly be satisfied. The very frequent active use of adjectives in poetry and in the prose of the Silver Age—as *nobilis* and *liber* in Horace—ought, also, to have been more distinctly recognized.

Two Volumes of "L'Art."*

A SALIENT feature of "L'Art" is the attention it gives to foreign, and particularly to English, art. Doubtless this is good policy in a publication which puts London on its title-page in a spot quite as honorable as that accorded to Paris; but it also marks the increasing liberality of spirit pervading France. For instance, the title-page of the second volume of 1879 (Vol. XVII) is composed by an Englishman, John Watkins, a graduate of the Birmingham and South Kensington schools of art. Nor does he only furnish the leading art publication of the world with a title-page; other decorative pieces in the volume are credited to him, such as a funereal cartouche at page 24, and another at page 137. Professor Sidney Colvin is also a contributor in the same line of research as that he pursues in "The Portfolio," the able English art publication of Mr. Hamerton. His paper in this volume is upon an unknown German master, who signed himself "E. T." Moreover, Frederick Wedmore undertakes to make the French better acquainted with the etchings of Turner, who made French rivers the study of many months of his industrious life; he sketches and slightly criticises Turner in relation to his "Liber Studiorum," as edited, with catalogue and description, by W. S. Rawlinson (London, 1878). These etchings are impressions taken by Turner from the plates at an early stage, before the addition of shadings and so forth, and serve as illustrations to the paper. Mary M. Heaton is still one more English contributor, the subject being the painter-poet David Scott, who was born in 1817 and died in 1849; and two designs for Coleridge's "Ancient Mariner" show his power and eccentricity. "L'Art" continues to pay some attention to American work. There are four studies from the life by George H. Boughton, reproduced in wood-cuts, and the sketches of E. A. Abbey at the Exposition receive from the reviewer much praise. An error has been made in the title of Mr. Abbey's large black and white, originally engraved for this magazine (February, 1876). It represents Mrs. Murray entertaining British officers while General Putnam escapes, whereas the meaning-

less title, "The Stage Office," has been given it by "L'Art." Du Maurier, of "Punch," has several excellent full-page fac-similes, and several other English artists, both men and women, receive varying marks of consideration. One of Doré's ventures into sculpture holds the vantage of a full-sized etching by Champollion. It is a study for a clock: Father Time stands on the globe which forms the clock, and with his scythe reaps among a mass of little Cupids, who mount and descend along clouds which support the globe, the base being formed of puffs of cloud. It is no better than Doré's vase, of which much was said at the Exposition. The biographies of artists contain one of the sculptor Auguste Préault, in which the biographer, Chesneau, sets before us the very man as he lived and battled. Préault belonged to the Romantics, and began his career as an inventor of bitter *mots* at the age of twenty. When he went to the first representation of Victor Hugo's "Hernani," and saw the pit paved with the bald heads of the Classicists, he cried out: "*A la guillotine, les genoux!*" His study of the nude made it natural that those bald heads should appear to him like so many bare knees. The brutality and recklessness of the cry was typical of the man. The bass-relief "Silence," which was made for the cemetery of Père La Chaise is a profoundly stirring piece of work; that called "La Tuerie," is like a dream of that Asiatic conqueror who is said to have built a palace of the skulls of his immolated victims.

Among the contents of volume XVIII, or No. 3 of the new series, are autograph sketches of Pietro Buonaccorsi, called Perino del Vaga, after a painter who employed him. However, modern art assumes by far the largest space in both volumes. There is some room for Frenchmen of the last two centuries, like Boucher and Cochin, but French and English art of to-day find most notice. Eugène Véron, the clever managing editor, finishes his review of the sculpture at the Salon of 1879, while Charles Tardieu completes the same service for the paintings. Mr. Comyns Carr, the London editor, examines the shows at Grosvenor Gallery and the Royal Academy in London. T. Chasrel reports on the Salon at Anvers, and Louis Brés describes the artistic expositions of Marseilles. Besides these there is a notice of the International Exposition at Munich, in which Théodore Jouret handles rather mercifully a gallery which was hastily formed, and which lacked the work of many of the strongest painters of Germany. "L'Art" gives also a list of the pictures in the Salon bought by the French Government. It seems that, owing to the prestige of such a choice, and the fact that such pictures will remain permanently before the public, artists are glad to sell cheaply to Government. The editor of "L'Art" objects to this, without, however, giving clear and sufficient reason. Owing to the low prices, artists naturally seek to have the price concealed.

In the course of his criticism of sculpture at the Paris Salon, the managing editor of "L'Art" makes some remarks that are to the point, and not only in reference to French art, but to our own. The sickly sentimental has been pretty much

* L'Art. Revue Hebdomadaire Illustrée. A. Ballue, Editeur. Cinquième Année. Tome II. Tome III. Paris and London, 1879. New York: J. W. Bouton.

laughed out of our sculptors and painters, but in place of it they are tending to substitute a bald realism. The American student in France can hardly escape this influence. M. Véron says :

“Execution is essential, perhaps, especially in sculpture; but the cleverest execution is not enough to constitute a work of art. It is necessary that it be under the direction of a thought, a will, a personality, and, in art personality shows particularly in the sentiment. It is that which makes the poetry of a work, a thing which seems either unknown to or disdained by the most of our contemporary artists. In consequence of their fear of rhetorical or declamatory work—for which they deserve any amount of praise, since sincerity is the first of all artistic qualities—they have come to esteem nothing but pure reality, clumsy and cold reality. They copy their models sincerely, exactly, icily. They execute a work of art as they might solve a problem in geometry. It is a most regrettable exaggeration. In order that the æsthetic formula shall be complete, it is necessary that a *love* of nature be joined to a *respect* for nature.”

Seldom does one come across a truer statement, or one which American artists need to take more to heart.

This volume holds the last essays on architecture written by the late Viollet-le-Duc, the able assistant of Véron in the management of “*L’Art*.” A summary of a discourse by this great writer on mediæval architecture, before a Paris school of drawing, occupies an early place in the volume. He spoke on the study of drawing in his usual liberal and energetic way. Five papers *De la décoration appliquée aux édifices* show his radical treatment of subjects which other men only dare to touch in the most careful manner. What do we mean, he asks, by the term decorative arts? Where do they begin or end? Does a work of art cease to be decorative when it is isolated and is not dependent upon a monument? Michael Angelo, he thinks, would have been singularly surprised had any one thought of talking to him about decorative art. He thought he was creating art pure and simple. Nor did any one consider such distinctions until the reign of academies of art. These were to Viollet-le-Duc abominations, and to them the leader, strenuously seconded by Lieutenant Véron, gave hard knocks quite to the time of his death. In this volume, “*L’Art*” has handsome fac-similes of charcoals by Andrea del Sarto and Raphael, but none of its contents is of greater interest than these last words of a distinguished intellect,—an intellect which has already left its mark on the art and architecture of the century.

“Souvenirs of Madame Vigée Le Brun.”*

FAME is almost as fickle a goddess as Fortune herself, and every whit as uncertain. The subject of these pleasant memoirs was, in her own day, one of the most admired of artists, the favorite of courts

and princes, and in her long and brilliant career tasted, at least, almost all the pleasures that make up the sum of human happiness. She was remarkable for her personal beauty, her manners had an irresistible charm, and the sweetness and sincerity of her nature gave an unaccustomed grace to a character of marked independence and originality. She was not born to riches, and in her long and industrious life she only laid up a modest competence for old age; but her admirable talent was a Fortunatus’ purse, which unfailingly supplied both her own modest wants and the wants, not so modest, of her spendthrift husband. More precious than riches were the friendships that made the true wealth of her existence, springing up like the flowers of May about her youthful feet, sweetening her pathway in middle life, and making her peaceful old age fragrant with delightful memories. It is true she did not find life a rose without thorns. In the terrible times of the French Revolution, she had the bitter experience of losing many friends, and seeing sights that long darkened her days and nights with their horror. A miserable husband fell to her share in the lottery of marriage,—a sieve of a man, who swallowed up her earnings, and, like a daughter of the horse-leech, continually cried for more; and her beloved daughter, from whom in her childhood and youth she never allowed herself to be separated, and for whom she made a thousand sacrifices, brought her in the end only grief, marrying ill, and entering a social world into which her pure-hearted and refined mother could not follow her. But even troubles such as these were not able to subdue Madame Le Brun’s constitutional cheerfulness, nor disturb her faith: they served only to temper her delight in living, and to make sweeter by contrast the many pleasures that remained to her. This private experience was the background to a public career of exceptional brilliance. Born in 1755, she began to paint portraits when she was very young; and, from the first, her marked talent brought her many sitters. Perhaps,—and she herself admits as much,—her beauty had something to do with her popularity as an artist; but, though she could not be ignorant of the admiration her lovely face excited, she says that her interest in her art and the delight she took in paintings made her indifferent to the homage she received. She painted in all six hundred and sixty-two portraits, and the long list includes almost every celebrity of her early and middle life in France and Italy, in Russia and Germany, and in England. Of course, being a devoted daughter of France, she gave her best powers to celebrate her own people; but, when the Revolution came, she fled from danger, and saved her life in traveling from one European state to another, practicing her profession wherever she found hospitality and employment. In France, she painted not only the queen and the royal children, but nearly all the members of the court, at which she was received with a favor that was almost affectionate. Madame Le Brun was a warm royalist; and in all her written pictures of the court and court life, we feel that we are listening to an enthusiastic woman who saw only the virtues

* *Souvenirs of Madame Vigée Le Brun*. New York: R. Worthington.

and none of the foibles of her friends, and of the people she honored. In reading her journal we wonder how such an elysium of goodness and purity as the court of Louis XVI. and Marie Antoinette could ever have been held responsible for the miseries and misfortunes of France. But, 'tis the same, when Madame Le Brun comes to Russia in the course of her travels; Catherine II. is in her eye a great, noble, and good woman, and the Russian court is almost as immaculate as that of France. It is true there are shadows in the picture, and the charming artist is more true to history in the picture she draws of the Emperor Paul. What has been said of France and Russia may also be said of Italy: we get only the splendid, picturesque side of life; the other side had no attraction for the artist. But it is not to be denied that the picture she draws is bright, intelligent, and instructive, and gives us a varied and striking record of one side of life in a momentous time. Indeed, so manifestly true is Madame Le Brun in her record of what she saw and heard (and she seldom leaves the track of her own personal experience), that we are supplied in her memoirs—she all unconscious—with reasons more plenty than blackberries for the turbulent discontent that was the characteristic of the popular history of the eighteenth century, everywhere in Europe.

After the Restoration, Madame Le Brun, once so admired and so famous, was neglected and almost forgotten outside the circle of her own family and friends. A new world was rising about her, and art which, up to that time, had been a plant of feeble growth in France, was striking out fresh roots, and bourgeoning with the blossoms of a splendid spring. In the postscript by her niece, Madame J. Tripièr Le Franc, appended to the present edition of these memoirs, it is stated that during Madame Le Brun's life-time no picture of hers was to be found in any one of the national collections. And indeed her name was in danger of being forgotten, had not a new edition of her "Souvenirs," the presentation of two of her best pictures to the Louvre by her niece, and lastly the enrolling of her name among the celebrities of her native country whose statues are to adorn the new Hôtel de Ville in Paris, brought once more into prominence the charming artist and woman whose beautiful face we meet to-day in so many places, reproduced by photography from the portrait painted by herself for the Uffizi Gallery in Florence.

Although no publisher's note informs us of the fact, we take it for granted, judging by certain peculiarities of expression, that the present American edition is a reprint of the same work recently published in England by Bentley. The original "Souvenirs" appeared in Paris in three volumes, published successively in 1834, 1835, and 1837, each volume containing a lithographed copy of a portrait by Madame Le Brun. It is a pity that the charming picture, prefixed to the first volume, of the artist with her daughter in her arms, could not have been reproduced for this American edition instead of the heliotype copy, or what appears to be such, of some

one's unhappy scratching with a graver, called on the title-page a steel portrait from an original painting by the author. This bears not any resemblance to any well-known portrait of Madame Le Brun and does her beauty injustice. Interesting as the book is in its present shape, it is really but a mangled version of the original, so many and so inexplicable on any known principle of editing are the omissions. Sentences and parts of sentences, paragraphs, whole pages, and at least two whole sections,—one called "Notes and Portraits," consisting of very clever and interesting accounts of famous people, and the other the account of her voyage in Switzerland,—are omitted and no intimation is given of the fact. Apart from the liberties taken with the text, the translation may be generally commended, although there are some surprising slips. The objective case of the pronoun "who" is hardly once used where it should be. Sometimes the translator misses the point of a story, as on page 88, where the pun upon Madame Du Barri's name is lost by "*du barri*" being translated "cask." The result is almost as amusing as that of the "*lapsus lingue*" joke in "Joe Miller." Names are in several cases given wrong; "*quincunxes*," a plantation of trees set in a particular way, is translated "quinces"; and for the familiar "School of Athens" of Raphael we read the "Athenian School." But considering the astonishing character of the common run of English hack translations of French and German art books, we may praise the present translation as uncommonly exempt from those mistakes which arise when a translator has only a boarding-school acquaintance of a few quarters with the language of his original.

"The Amateur Poacher." *

THE "Amateur Poacher" is a sort of continuation of the author's first book, "The Game-keeper at Home," and is replete with the same qualities that made that volume so readable and entertaining. We see the world more from the stand-point of the poacher this time than from that of the game-keeper, and the glimpses are novel and refreshing. The author, who is probably the son of some well-to-do English farmer, plays at poaching himself, and recounts his adventures with great minuteness of detail and picturesqueness of effect. What portraiture he gives us, too, of the professional poacher in "Oby and his System," and in "Luke, the Rabbit Contractor." These chapters are a novelty in literature. Oby summarizes his "system" pretty well in the following passage:

"The reason I gets on so well poaching is because I'm always at work out in the fields, except when I goes with the van. I watches everything as goes on, and marks the hares' tracks and the rabbit buries, and the double mounds and little copses as the pheasants wanders off to in the autumn. I keeps a 'nation good lookout after the keeper and

*The Amateur Poacher. By the Author of "The Game-keeper at Home." Boston: Roberts Brothers.

his men, and sees their dodges—which way they walks, and how they comes back sudden and unexpected on purpose. There's mostly one about with his eyes on me—when they sees me working on a farm, they puts a man special to look after me. I never does nothing close round where I'm at work, so he waits about a main bit for nothing."

Like the author's previous writings, this book has a marked local flavor—it savors unmistakably of English rural life and scenery. It is full of the sounds, the odors, the flowers, the trees, the birds, the animals, the very atmosphere of English country life. Those "double mounds," that recur so often, where the rabbits burrow, where you can hear them "thump, thump, thump" underground, as you pass, and where the pheasants skulk, and the birds hide—there is nothing like them in the American landscape, for they are the fences, the boundaries of the fields, merely earth thrown up and planted with trees and bushes. Such words as "withy," "stoles," "harling," "copses," "mere," "buries," "moucher," "the coombs" are of frequent occurrence. "A fogger going to fodder his cattle," "before the summer ricks are all carted," "red haws on the hawthorn and hips on the briar," etc.—how Englishy such sentences sound! "The keen, plaintive whistle of the king-fisher"—evidently that is not the American king-fisher, with his loud rattle. The British bird, which is smaller than ours, takes to the shore quite a large fish and devours it at his leisure; our species seldom or never strikes a fish larger than he can bolt on the spot.

But to the American reader, perhaps the most astonishing revelation the book contains, like that of its predecessors, concerns the amount of game and of wild life of all kinds in England. Hares and rabbits are evidently more numerous there than chipmunks in this country. They are netted, and ferreted, and trapped, and shot, and taken in all manner of ways, and yet the fields are overrun with them. Some farmers derive quite a revenue from the sale of their rabbits. The vermin, too, that prey about the game—weasels, stoats, hawks, owls, crows, jays, magpies, etc., exist in prodigious numbers. Such a slaughter of owls, and crows, and jays in this country as annually takes place in the great game preserves of England would quickly exterminate the species.

Johnston's "History of American Politics."*

THIS little volume is a valuable contribution to our political literature,—valuable not only in itself, but as well in the enlarged study of and interest in politics which it is calculated to incite. Mr. Johnston's aim, "not to present the politics of the States, or to criticise party management, but to make our national political history easily available to young men," has been closely adhered to. That there is room and need for such a work goes without saying. The fact that our political history has not

been easily available, and that it certainly has not been availed of, has often furnished matter for concern to those wise and thoughtful statesmen who recognize the danger of ignorance in a country where the people rule. However intelligent the masses of this country may be as compared with those of other nations, there is yet a painful lack of information prevalent among all classes, not excepting even the more educated and the politicians, regarding the true character of the important political movements that mark our history and the underlying principles involved in the struggles of parties. The author well says: "It is of interest to the whole republic that young citizens should be able to learn that true national party differences have a history, and a recognized basis of existence, and should be prevented from following factitious party differences, contrived for personal objects by selfish men." It would be of no little interest, and doubtless a telling commentary on the political intelligence of the general voter, could we ascertain what proportion of young men who ally themselves to one or the other of the great political parties do so from conviction founded on knowledge of the principles of that party,—as against those who merely follow in the footsteps of their fathers, or become partisans from any reason but that of intelligent choice or consideration.

Starting with the division of the opposing parties into the two classes called the Strict Constructionist, and the Loose or Broad Constructionist, parties, as these respectively were in favor of restricting or enlarging the powers of the federal government, the author plainly draws the party lines in the statement, that "this question of a strict or a loose construction of the Constitution has always been at the root of legitimate national party differences in the United States," and that "all other pretended distinctions have been either local and temporary, or selfish and misleading." These elementary lines, it is true, were at times obscured, if not wholly lost sight of, through the heat of personal contests, while more than once the parties seemingly changed places on the issue of federal growth. But in the main the course of the parties has been clearly marked. The Republican-Democratic faction has clung tenaciously to its strict construction of the Constitution; and under the various names of Federalist, Whig, and Republican, the party of broad construction has been as pertinacious as it has been generally successful in securing the adoption of its measures for building up a strong central government. Mr. Johnston has succeeded admirably in outlining sharply and concisely the position and important movements of the opposing parties from their origin to the present administration. There are no waste sentences in the work. The style is plain, and in keeping with the subject; the arrangement is not less commendable than the plan. A chapter is devoted to each administration. The matter in these includes, in separate paragraphs, the sessions of congress, and the important bills proposed and discussed, legislative action on all measures of national interest, the development of political

* History of American Politics. By Alexander Johnston. A.M. New York: Henry Holt & Co.

ideas and parties, the choice and election of presidential candidates, and, in brief, all the prominent events that make up our political history. The author acknowledges many sources of information, and has used them with nice judgment, omitting nothing that was germane to his purpose, while compressing the mass of essential facts to the last degree possible with clearness. The result is not only a most valuable hand-book for students and young men in general, but a text-book which the politician will find it to his advantage to use for reference, and a short history which every citizen who cares to be well informed upon a subject of vital concern may read with profit and pleasure.

Rousselet's "Serpent-Charmer."*

M. LOUIS ROUSSELET, the author of that admirable work, "India and its Native Princes," has tried his hand upon a book for young people, the scenery of which is taken from India. "The Serpent-Charmer" is a story of the Indian mutiny, sufficiently thrilling to satisfy the appetite of the most adventurous of boys. The central figures of the story are Andre and Bertha, the children of a French resident of the Maharatta district, Mali, the serpent-charmer, and Miana, his young assistant. To these may be added Hanouman, a learned monkey, and Saprani, a pet Cobra di Capello. This motley band, after the breaking out of the mutiny, and the destruction of the home of the young people, set off on a long pilgrimage across India, fleeing from the rebels, and in search of Bertha, who has been abducted from them by Nana Sahib, the leader of the mutiny at Cawnpore.

As may be divined, the adventures of the fugitives, their hair-breadth 'scapes and moving accidents, furnish forth a goodly array of the most exciting details. The scenery of the country, its natural history, the manners of the people, and their superstitions and customs, are all brought in review as the travelers move from point to point in search of safety and their lost companion. They meet with a great number of surprising incidents, all of which are possible, and many of which have happened to somebody at some time. Meanwhile, the dark and terrible story of the mutiny is slowly unfolded; and in this respect the work is of real value to young readers, as it will serve to fix in their minds the outlines of that memorable contest between the British power in India and the expiring vitality of native rule. Nana Sahib, who figures under his proper title of Prince Doundou Pant Rao, heir-presumptive to the empire of the Maharattas, is depicted in his true colors, and the black treachery of which he was guilty is described in the incidents of the tale. Of course, as the mutiny was finally crushed, the story ends happily, though the truth of history must needs leave the wicked Nana Sahib at liberty, escaping the penalty which justice, poetic or strict, would have visited upon him for his crimes. The

work is an attractive one for young people, and it may safely be put into their hands by those who dread the influence of what is known as "sensational" reading on youthful minds. It is fully illustrated with engravings after designs by A. Marie.

Recent Poetry by Women.

A GOOD text for a short discourse on the poetry of women forces itself upon our critical consideration in the shape of five volumes of recent poetry, the work of as many American women. We have read them all carefully,—we had almost said prayerfully,—and have come to the conclusion that the writers would have done much better if they could have compelled themselves to take more pains. All have something to learn, and something to unlearn, and the last mental process will probably be to most the harder of the two. It has not disheartened Miss Nora Perry, we are happy to say, for in her second volume* she no longer allows herself to indulge in the music of the refrain—a dangerous music, which is certain, when long pursued, to degenerate into jingle. Miss Perry has not yet discovered her strength and her weakness, nor are we at all sure that we have discovered them either; but, judging by what is before us, she inclines toward the dramatic, and is disinclined toward the meditative, side of poetry. She prefers to project herself into imaginary characters and experiences, rather than to study what she is, and thinks, and feels. The best things that she has done hitherto are in the direction of objective poetry, to which she has endeavored to give a dramatic form. In the opening poem of the present volume, she depicts the emotions of a man in daily contact with a woman who is beloved by his friend, and whom he loves in spite of himself and his fidelity to his friend. In the second-poem, "For the King," she depicts the feelings of an Italian woman toward Victor Emmanuel, with whom she has danced at a ball in her youth, and her admiration of his bluff, soldierly character. In the fourth poem, "From a Convent," she depicts the passion and rage of a loving girl who is imprisoned by her high-born relatives; and in the eighth, "A Tramp," she depicts the querulous, worldly disgust of one of that numerous class of vagabonds. These poems, and one or two others which might be named, come under the head of serious dramatic studies. "The Wager," "If I were you, sir," and "A Deux Temps," are light enough in their intention and execution to come under the head of comic studies; while "Barbara," "Lady Wentworth," "Bunker Hill in 1875," and "Boston Boys," are studies of national balladry. There is considerable range, it will be perceived in these three walks of poetic art, and Miss Perry has acquitted herself creditably in all, though she has still left something to be desired in her work in each. "Her Lover's Friend" is worthy of the place it occupies, for it is not only the most agreeable poem in the

* The Serpent-Charmer, by Louis Rousselet. Translated from the French by Mary De Hauteville. New York: Charles Scribner's Sons.

* Her Lover's Friend and Other Poems. By Nora Perry. Boston: Houghton, Osgood & Co. 1886.

volume, but it is by far the most finished one. Next to this we should place "The Famous Free-Lance" and "The Rebel Flower," and with these the ballad of "Bunker Hill." We prefer her serious to her comic vein, and we think she appears to most advantage when she is most objective.

The poetry of Mrs. S. M. B. Piatt, who has just published her fifth volume,* belongs to the same class as that of Miss Perry. She is nothing if not dramatic, and nothing if not subtle. Her method is a profound one, in that it works from within outward, and a faulty one, in that it implies more sympathy than she is likely to obtain, and more intelligence than is possessed by one reader in a hundred. Her conceptions are no doubt clear to her, but they are frequently obscure to others. Her situations may be striking from a psychological point of view, but they are not such as commend themselves to the eyes of common men; the stage upon which her tragedies are played is of the soul, not of the senses. She not only demands an apprehension which is denied to the many, but she demands also that they shall forget the language which is natural to them, and learn the language which is natural to her—a primitive speech, so to speak, because it leaves so much to be supplied by intuition and imagination. It is wayward, abrupt, enigmatic, and prolific in hints, and innuendoes, and questions it neglects to answer.

What we have said applies to Mrs. Piatt's poetry whether it is directly dramatic, as in the poems included here under the head of "Dramatic Persons and Moods," or indirectly dramatic, as in the poems addressed "With Children." It is her sign-manual, and it is more strongly impressed upon "A Wall Between," than upon anything else in the volume. We shall not attempt to analyze this remarkable production, in which a dying wife confesses herself to her husband, who has visited her in the disguise of a priest, but content ourselves with commending it to Mrs. Piatt's readers as a good example of her excellences and defects, and as containing isolated lines and passages noticeable, as is most of her work, alike for vigor and originality. Perhaps the most finished things here are the "Double Quatrains," of which there are ten. They are very suggestive, especially the third one, which we give :

BROKEN PROMISE.

"After strange stars, inscrutable, on high;
After strange seas beneath his floating feet;
After the glare in many a brooding eye,—
I wonder if the cry of "Land" was sweet?"

"Or did the Atlantic gold, the Atlantic palm,
The Atlantic bird and flower, seem poor, at best,
To the gray Admiral under sun and calm,
After the passionate doubt and faith of quest?"

It is refreshing to turn from the elaborate poetic work of Mrs. Piatt and Miss Perry to the simple verse of Mrs. Mary Mapes Dodge, whose bright

and unassuming, little volume* will earn her many friends. It reveals a very decided poetic talent and is as natural and unaffected as any modern writing can be. There is no trace of labor in it, and no evidence of anxiety to discover new themes, nor does there appear to be much ambition to handle old themes in a new way. Mrs. Dodge is impressed by common things; the light of a flower, the song of a bird, sets her to thinking and singing. She thinks clearly, and sings sweetly, and leaves with us a pleasant feeling when she is done. One would say from these poems that she is fond of out-door life, and that she has a sunny temperament, which finds its happiness in nature, and in the cheerful performance of every-day duties.

There are between fifty and sixty poems in Mrs. Dodge's volume, all of which are marked by the qualities we have indicated. Single lines and epithets showing much imagination are more numerous than single sustained poems. It is not easy to say which are the best, they resemble one another so closely, and are so evenly written; but those which we have read with most pleasure, are "In the Cañon," a picturesque description of Colorado scenery; "There's a Wedding in the Orchard," a little, off-hand rural sketch; "The Two Mysteries," a striking piece of poetic philosophy; "Secrets," a fairy-like lyric of love; "My Window Ivy," "The Minuet," and "A Birthday Rhyme." Perhaps the most poetical poem,—the one which goes deepest in intuition,—is "Once Before," the purport of which will be detected in the opening lines:

"Once before, this self-same air
Passed me, though I know not where.
Strange! how very like it came!
Touch and fragrance were the same;
Sound of mingled voices, too,
With a light laugh ringing through:
Some one moving—here or there—
Some one passing up the stair,
Some one calling from without,
Or a far-off childish shout;—
Simple, home-like, nothing more,
Yet it all hath been before!"

If anything should make a critic hesitate in bestowing praise or censure, it is the little volume by the young New England girls who sought poetic recognition a year or so ago by the publication of "Apple Blossoms."† It consists of thirty-one separate poems, upon as many Berkshire wild-flowers, fourteen of which were written by Miss Dora Goodale, and seventeen by her sister, Miss Elaine. Before the idea of a *seriatim* treatment of the flora of a section, the muse of an older poet would have hesitated long. The result in this instance hardly justifies the venture. There is little, if any, advance on the previous book. As before, the versification is good, and the sentiment pleasing; but beyond that we cannot go, for, with two or three exceptions, the poems are not striking, and, of course, not original.

We have a kindly feeling toward Miss Charlotte

* Along the Way. By Mary Mapes Dodge. New York: Charles Scribner's Sons.

† In Berkshire with the Wild Flowers. By Elaine and Dora Goodale, Authors of "Apple Blossoms." Illustrated by W. Hamilton Gibson. New York: G. P. Putnam's Sons.

* Dramatic Persons and Moods With Other New Poems. By Mrs. S. M. B. Piatt. Boston: Houghton, Osgood & Co. 1880.

Fiske Bates, and toward her volume of verse, which is free from pretension of every kind.* It is carefully, but not skillfully written, and is noticeable for gravity of thought, earnestness of purpose and restricted range. She has not sought her themes in books or in communion with other minds, but has found them in herself, in her sorrows and suffer-

* Risk, and Other Poems. By Charlotte Fiske Bates. Boston: A. Williams & Co. 1879.

ings, and in her spiritual hopes and consolations. That she has begun well is evident, we think, from this little poem, which is entitled "Treading the Circle":

"So far, so far gone out of sight,
My strained eyes follow thee no more.
Thou to the left, I to the right;
Never to meet as heretofore.

"Yet though the distance grows so wide,
We tread Love's circle year by year:
We are nearer on the other side
The farther we are sundered here."

THE WORLD'S WORK.

New Fruit-Press.

A PRESS which is constructed upon quite a novel plan, and which presents some features of value to the householder, has been invented for the purpose of extracting juices from fruits. A tapering screw, journaled at its larger end in a bracket, or holder, designed to be fitted to the edge of a table with clamps, and having a suitable handle, forms the press. An iron cylinder tapered to fit closely over the screw, carries at the large end a hopper for the fruit, and at the small end a spout for the rejected refuse. The lower side of the cylinder is open, and strainers of different degrees of fineness may be placed inside to cover this opening. In use the cylinder is slipped over the screw and clamped to the bracket, and the fruit to be pressed is placed in the hopper. On turning the handle the fruit is conveyed along the cylinder and pressed at the same time, the juice escaping through the strainer to a vessel placed below, the dry skin, seeds, and other refuse, being expelled at the end of the cylinder. The same apparatus, by a slight change in its parts, may be used for a sausage-stuffer. In expressing juices the machine saves all handling of the fruit or refuse, and will, no doubt, prove of convenience in domestic economy.

Bridge Building.

IN erecting a single-span bridge recently in France the experiment was tried of building the bridge on shore and then pushing it over the stream into its place. The span was of iron and of a common pattern, and was 96.5 meters long (314 ft.), and weighed about 1,300,000 kilos, or 1,250 tons. Rollers were placed under the bridge and to the forward end was fastened a lighter span belonging to another bridge, with another at the rear end. When finished the bridge was pushed out over the river, and the forward portion reached the opposite bank before the center of gravity of the main span passed the rear or home shore. The advanced part met rollers and moved on supporting the main span till it crossed the river, when it was removed, and the bridge was easily put in its permanent position. This operation though claimed as novel was entirely successful, but it seems to have been hinted at by a bridge erected a year or two ago

in this country. In this case the bridge was erected piece by piece from both shores, being supported by wire ropes passed over towers on the banks and temporary towers in the river. It met in mid-air just as permanent supports were built up from below, all the work meeting at one spot in mid-stream at a great height above the water.

Etching Metals.

IN ornamenting metallic surfaces by etching it is proposed to cover the metal with an actinic film (probably gelatine sensitized with bichromate of potash), and placing a transparent positive over it and exposing it to the sun. The light portions would admit the light to the film and it would be hardened, while the darks, in shade, would be untouched. On removing the positive the dark and still soluble portions are to be washed away. The etching acid is then poured over the metal, the film keeping it away from the light portions while it is free to attack the dark parts. By such a process, it will be observed, the etched parts would be black and the lights in the natural color of the metal. The process seems to be worthy of experiment.

Glass Sleepers.

GLASS sleepers for street railways are now under trial. They are made by the Sieman's glass toughening process, which differs somewhat from the well-known La Bastie process. Under careful experiment they have been found to have very considerable strength, or, at least, sufficient for light railways. So far they have been made of a rather small pattern for longitudinal sleepers, but there seems to be no reason why they may not be made of the usual size for heavy railway ties. The glass is of the cheapest quality. They may even be made from furnace slag, as cheap bottles are already manufactured, and once in the road-bed they would last for centuries, as far as mere decay is concerned.

The Audiphone.

THIS instrument, designed to supplement the ear in cases of partial deafness, has been recently introduced and has already proved of marked value in enabling many deaf persons to hear sounds of all

kinds and even spoken words. In appearance it resembles a large black fan, being formed of a flat, thin and flexible disc supported by a handle, the whole being made of vulcanized rubber. Attached to the upper edge of the fan are cords that pass through a clip, or binding ring, on the handle. In use these cords are drawn down, bending the fan somewhat, and are secured by the clip. The deaf person holds the audiphone by the handle with the upper edge resting lightly on the upper teeth and with the convex side of the fan outward. Sonorous vibrations of all kinds striking on the curved surface of the audiphone are imparted to the teeth as sensible vibrations, and are then conveyed through the teeth and the bones of the head to the internal ear. The auditory nerve conveys the resulting sensation to the brain precisely as if the vibrations had reached the internal ear through the usual channel of the external ear. It will be seen that this implies that the internal ear is perfect, otherwise no vibrations reaching it through any means would have any effect and the brain would not be aware of any sensation. The auditory nerve must also be perfect, and thus the audiphone is practically an apparatus for supplementing the loss or injury of the external ear. Repeated trials have shown that the instrument enables many deaf persons to hear distinctly. On the other hand, some deaf persons are not in any way aided by it, and the conclusion is that such persons have lost the use of the internal ear or the auditory nerve, or both. The loss of the first must, it would seem, prevent the recovery of the hearing by the use of the audiphone as it cannot be imagined that it conveys sound to the nerve without translation through the ear. From personal observation with the audiphone it appears to convey the sonorous vibrations to the ear through the teeth, just as a long wooden rod held in the teeth will convey the vibrations of the sounding board of a piano, though the piano is in another room and out of hearing by the ear. In using the audiphone during conversation there is no movement or vibration felt by the teeth; in listening to a piano there is a very faint sensation as if the audiphone vibrated slightly, while with the handle of the audiphone resting on the sounding-board of the piano the vibrations are so violent as to be painful to the teeth. By closing the ears a person with even acute hearing can observe the admirable manner in which the instrument conveys spoken words to the ear. The audiphone will prove to be of great value to deaf mutes, as it enables them to hear their own voices and thus to train them to express words, while, before, they could only make inarticulate sounds. A variation of this instrument has been introduced employing a diaphragm held in a telephone mouthpiece, and free to vibrate under the influence of sounds. This is connected by a string to a bit of wood that may be held in the teeth. In use the hearer places the wood between his teeth, the string is drawn tight and the speaker speaks through the telephone mouthpiece, the vibrations of the diaphragm being then conveyed to the teeth through the stretched string. This

apparatus is said to work with success, but it seems to lack the convenience and simplicity of the audiphone.

The Steering Screw.

THE attempt to make a propeller that should be at once screw and rudder was tried some time since upon a small steam launch with entire success, and the screw, together with a new type of marine engine, has now been applied to a sea-going boat, belonging to the torpedo service of the Navy. This boat, the *Alarm*, is armed with one fifteen-inch gun, placed at the bows, and three torpedo spars. The *Alarm* is designed to be fought "bows on," the boat itself making the gun carriage, and to train the gun the entire boat must be moved by the gunner. This implies a perfect control of the boat, so that it can be turned completely round on its center. The torpedo spars are run out under water from the stern and from each side of the bows, and for their management it is also essential that the boat be under far more complete control than can be obtained by the ordinary screw and rudder. The new screw was applied to the *Alarm* for the double purpose of moving and steering the boat, and handling its gun and torpedoes. To understand this invention the engines built to move the screw must first be examined. There are two compound horizontal engines, placed side by side near the stern of the boat. The two cylinders of each engine are placed in line with one piston for each pair, the high pressure cylinders being forward with the two low pressure cylinders on each side of the condenser. The engine frames are toward the stern and make the guides for the piston rods, so that the engine is much like a pair of upright engines, with a condenser between their feet and laid down on the side. At the foot (or stern) of each frame is a bell crank, directly connected on one side with the piston rod, and on the other side with a rod connected with a crank on the head of the upright screw shaft. The two rods from the engines are placed at a quarter angle on the shaft, and the two engines are thus joined and move together. This style of engine and its position are entirely new, and show great ingenuity, for the problem is to supply a small and narrow boat with very powerful engines, to place the engines at the stern, and at the same time to distribute the weight in an exceedingly limited space. The vertical shaft stands immediately in front of the rudder, and is supported in a journal in the hull and steadied by a second and lighter bearing on an extension of the keel, that reaches to the rudder post. Near the bottom of the shaft on a line with the screw is a gearing for imparting the motion of the upright shaft to the short, horizontal shaft of the screw. The screw is six-bladed and is designed to move forward only, as the engine has no reversing gear. To understand the next and most important feature of this invention, it must be observed that the screw is supported by a sleeve, or casing, that surrounds the shaft, and is free to turn in any direction in a horizontal plane; in other words, the screw may be

turned round and pointed in any direction. The sleeve passes through the boat, and is surmounted by a horizontal geared wheel. This wheel is controlled by a worm gear, connected by shafts and suitable gearing with a horizontal hand-wheel in the wheel-house on deck, just in front of the engine. By this appliance, the pilot in the house turns the screw about in any direction, whether it is at rest or in motion. In going ahead, the screw is placed behind the shaft. To steer to the right, the screw is turned to the left, and then the whole force of the engine is spent in pushing the stern of the boat to the left. If she were at rest she would turn round on a fixed point or pivot. If previously going ahead she would describe a curve to the right, that would be the result of the previous forward motion, and the tendency to turn on a pivot, and if the screw were kept in this position, the curve would turn on itself till the boat simply turned round on its center. To move the boat astern, the screw is turned completely round, and this without stopping the engine, as it would be practically driving forward. All movements of the boat in turning, backing, and moving in every imaginable direction, to avoid a collision, in running another vessel, in training the gun or torpedoes, are controlled by the pilot, by moving the screw, and at the same time the engines work continuously at full speed ahead. The result of this combination of screw and rudder is a more complete control of the vessel than can be obtained from any form of screw and rudder now in use. For quick turning or sudden reversal of the screw, a supplementary engine is added, that can be applied to the steering gear to assist the pilot in moving the heavy screw and its casing in the water, so that, if desired, the boat may be steered by steam. The boat is also provided with a rudder for use in case of need. This steering screw, with, perhaps, a somewhat different style of engine, would seem to be of great value in Western rivers, where a winding channel demands a complete control of the boat.

Mechanical Extraction of Cream.

THE separation of cream from milk by allowing it to rise and float on the top, while easy and convenient, is slow, and attempts have been made to employ mechanical means to the work. For this purpose a machine has been brought out which operates on the principle of the ordinary rotary dryer. The apparatus consists essentially of a circular tank, a holder, supported by an upright shaft. Surrounding the shaft is a tube or sleeve, slightly larger in diameter, and outside of this is a second sleeve, still larger, thus giving two annular pipes reaching into the tank. From the outer pipe extend smaller pipes, radiating in every direction and entering the tank near the outer edge. Under the tank is another pipe, open at the lower end and communicating with the tank above, and a pail, or other vessel, below. In operation the tank is filled with milk, and the shaft is turned by steam or other power at a speed of about 2,000 revolutions a minute. This motion at once tends to separate the

cream from the milk, or, better, the milk from the cream, by centrifugal force. The milk is driven toward the outer edge of the tank, while the cream gathers in the center. This separation takes place at once, and in a few minutes the cream may be drawn out through the central pipe, and the milk, taken from near the edge of the tank, through the outer pipe. At the same time, new milk may be added to the tank through the supply pipe below, the centrifugal tendency of the milk in the tank being sufficient to draw up new supplies from the pail or other vessel below. Thus the separation of the milk from the cream is continuous so long as the supply of fresh milk is maintained. The cream extracted by this machine is reported to be entirely free from milk or water, while the milk is completely relieved of all its cream, showing a perfect separation of the two. Appliances are provided for regulating the density of the cream and for carrying the process to completion without waste of time or material.

Novel Photo-Printing Process.

A NEW method of making gelatine films for actinic processes has been brought out that is quite the reverse of those now in use. In sensitizing plates and films for photo-printing, the gelatine is charged with bichromate of potash, and on exposure to light, the parts exposed become insoluble, while parts in shade are soluble and may be washed away with water. In the new process this is reversed, and the prepared gelatine film is insoluble when made and remains so while kept in the dark. On exposure to light under a transparent negative the portions in light become soluble, and may be washed out, leaving the shaded portions in relief. When applied to the reproduction of line-drawings the gelatine film may be covered by a positive, or a pen-and-ink drawing on thin paper, and the light will act through the translucent portions, leaving the shaded parts untouched. When sufficiently exposed, the film is placed in warm water, when the soluble parts (lights) will be washed out, leaving the drawing (shades) in relief. From this, it is easy to see, molds may be taken for casting in type-metal for ordinary printing. The formula given for making the solution to be mixed with the gelatine is as follows:—Water, 100 cubic cents.; iron perchloride, 3 grams; tartaric acid, 1 gram. The proportion of gelatine is not yet announced. The process is one that, if all that is claimed for it be true, promises to simplify and cheapen photo-printing.

Simple Electrical Signal.

FOR dispatching a fixed signal, as in fire alarm lines, and in all mere calling and warning, a new device for giving the call or signal without the aid of machinery, has been introduced. The apparatus consists of a board or other non-conducting tablet, on which are laid strips or points of wire arranged in pairs and in a vertical line. These pieces of wire and points correspond to the dots and

dashes of the intended signal, and are parts of the line circuit. To send a signal it is only necessary to pass by hand a piece of metal down and over the wires and points in turn, the metal being wide

enough to unite each pair and close the circuit as it passes. The simplicity and cheapness of this method of signaling seem likely to make it of general use everywhere.

BRIC-À-BRAC.

The Beggar's Mirror.

A Fable.

A PERSIAN beggar—once it came to pass—
Acquired an old but curious looking-glass,
Which had a value for the shiftless tramp
As wonderful as had Aladdin's lamp.
For, looking on the broad, clear mirror's face,
All persons were endowed with heavenly grace.
The veriest hag who stood a moment there
Found that her face became divinely fair,
And no coarse clown could so ill-favored be
But in this glass great beauty he could see.
So the shrewd beggar, when he strolled about,
Failed not to bring the famous mirror out,
And, holding it in front of those he met,
Unnumbered pennies he was sure to get.

Now, when the beggar died, unto his son
He gave the glass to use as he had done.
But though the son went all the country through,
He let none but himself the mirror view,—
For, finding his own face so fair a sight,
He simply looked at it from morn to night,
Till, when he came unto his house once more,
Each day his purse was empty as before.

MORAL.

They who spend life in vanity and pride
Will find their feast set forth by Barmecide;
"Who draws the world to Flattery's glass gains
pelf,

But he's a fool who looks in it himself."

JOEL BENTON.

The Polyphone.

BY IRWIN RUSSELL.

PROFESSOR JONES was very wise,
And wore green goggles on his eyes—
Or 'twould be better, I suppose,
To say he wore 'em on his nose—
And was so very tall and slim
The street-boys made a jest of him,
And to his garments would attach
The label: "Here's a walking match."
Yet this ungainly friend of ours
Made daily gain in mental powers.
To him, each coming moment brought
Some thing of moment—fact or thought—
And he could bid the boys defiance
When rambling in the paths of Science.

For many weeks, Professor Jones
Made study of the laws of tones.
Of phonographs, and telephones,
And megaphones, he had a store
That filled up half his study floor—
The number of his tools, indeed,
Would make a work too long to read
With any sort of satisfaction;
But magnets were the chief attraction.
With these he labored, much intent

On making a new instrument
Which should, by means of sound-vibrations,
Make both "transmissions" and translations,
Said he: "For speech, we must have tone,
And every language has its own—
(Our high-toned English such-and-such,
And so-and-so the lowest Dutch)—
Its given rules to guide inflection
In some particular direction.
There's philologic evidence
That all our languages commence
In some lost parent tongue—each root
Each nation modifies to suit—
And languages, 'tis clearly found,
In no way differ but in sound.
Now, diaphragms may well be trusted,
If once they're properly adjusted
For language A and language B,
According to the phonic key,
(And then connected in a circuit
By persons competent to work it,
To transpose these root-derivations
Which differ with the tones of nations—
So if one 'sends' an English sermon
'Twill sound a sound discourse in German,
And our Italian learned at home
Can be well understood at Rome."

So saying, the Professor toiled,
And hammered, polished, filed and oiled,
Until, adjusted and connected,
Behold the polyphones perfected!
One stood upon the study table,
And one was down-stairs in the stable,
Where curious neighbors might not spy it,
And naught remained to do but try it.
A boy placed at the sending station,
To speak (for a consideration)
The noble language of our nation,
Professor Jones hied up the stair
To listen to the sounds, up there,
Which would at once, no doubt, determine
If English could be changed to German.

That boy below, sad to relate,
Was not in a regenerate state:
His language did not smack of schools,
Or go by proper laws and rules—
His speech was very shrill, but oh!
Its tone was most exceeding low!
So then and there the stable rang
With slang, and nothing else but slang,
Which, having no equivalent
In German, clogged the instrument—
And while the disappointed Jones
Stood quaking at the horrid tones
That came from the receiving-plate,
Discordant, inarticulate,
The boy began the last new song—
There was a clang, as from a gong—
And shattered were the polyphones,
And eke the intellect of Jones!



DESIGN FOR A BICYCLER'S HANDKERCHIEF.

An American Sketch.

His heart is all of English oak,
 His trowsers all of English kersey,
 He always rows the English stroke—
 And yet he came from North New Jersey.

He docks his horses' flowing tails,
 He drives an English cart, with Buttons;
 His beard is like the Prince of Wales',
 His eye-glass like the Earl of Mutton's.

His satin scarf is Oxford blue,
 And cut-away his English coat is,
 And when he speaks, oh, English too
 The difficulty in his throat is.

He calls his cousins' dresses 'frocks,'
 And rides upon an English nag
 To hounds—although the English fox
 Is started from a pudding-bag.

J. Edmonds-Jones he writes his name;
 And yet, if you'll believe me, sirs, he
 Was known as 'Jim' Jones when he came
 Some years ago, from North New Jersey.
 NELLIE G. CONE.

Beside Love's Bier.

MEN came and wondered, when he died,
 And stood with wet eyes by his bier.
 "We never dreamed," some wildly cried,
 "That Love could die, he was so dear;"
 Some only looked awhile and sighed,
 Then went their way; they had no tear;
 One moaned: "I've wandered far and near,
 And sought for Love, and would have died
 For his sweet sake,—I find him here;"
 Another kissed his cold, white brow:
 "Farewell," he cried. "Thou wilt not move;
 Eternal slumber holds thee now:
 No resurrection comes for Love!"
 But one who stood apart a space
 Drew near him gently. "Love," said he,
 "He never truly knew thy face,
 Who saw thee dead, nor died with thee."
 R. T. W. DUKE, JR.

Epigrams.**TO DEATH.**

HARSH dealings at thy hands do all men seek,
 Or seem to seek, who speak but ill of thee,
 Death, / thy name with praise shall ever speak—
 Thou canst afford to give long life to me.

TRUTH.

"Truth dwells in wells." How old tradition lies!
 For truth dwells not in wells, but in my lady's
 eyes!
 Yet should you for the fable still feel ruth
 I'll call them eyes no more, but merely wells of
 truth.

TO POETS.

When you've contrived in language wondrous
 terse
 Into one epic some high theme to cram,
 Take my advice, burn all your ragged verse—
 Expand it all into an epigram.

CHARLES H. DENNIS.

From a Counting-house.

THERE is an hour when first the westering sun
 Takes on some forecast faint of future red;
 When from the wings of weariness is shed
 A spell upon us toilers, every one;
 The day's work lags a little, well-nigh done;
 Far, dusky lofts through all the close air spread
 A smell of eastern bales; the old clerk's head
 Nods by my side, heavy with dreams begun

In dear dead days wherein his heart is tomb'd.
 But I my way to Italy have found;
 Or wander where high stars gleam coldly
 through
 The Alpine skies; or in some nest perfumed,
 With soft Parisian luxury set round
 Hold out my arms and cry "At last!" to
 you.

H. C. BUNNER.

SCRIBNER'S MONTHLY.

VOL. XIX.

MARCH, 1880.

No. 5.

THE TILE CLUB AFLOAT.

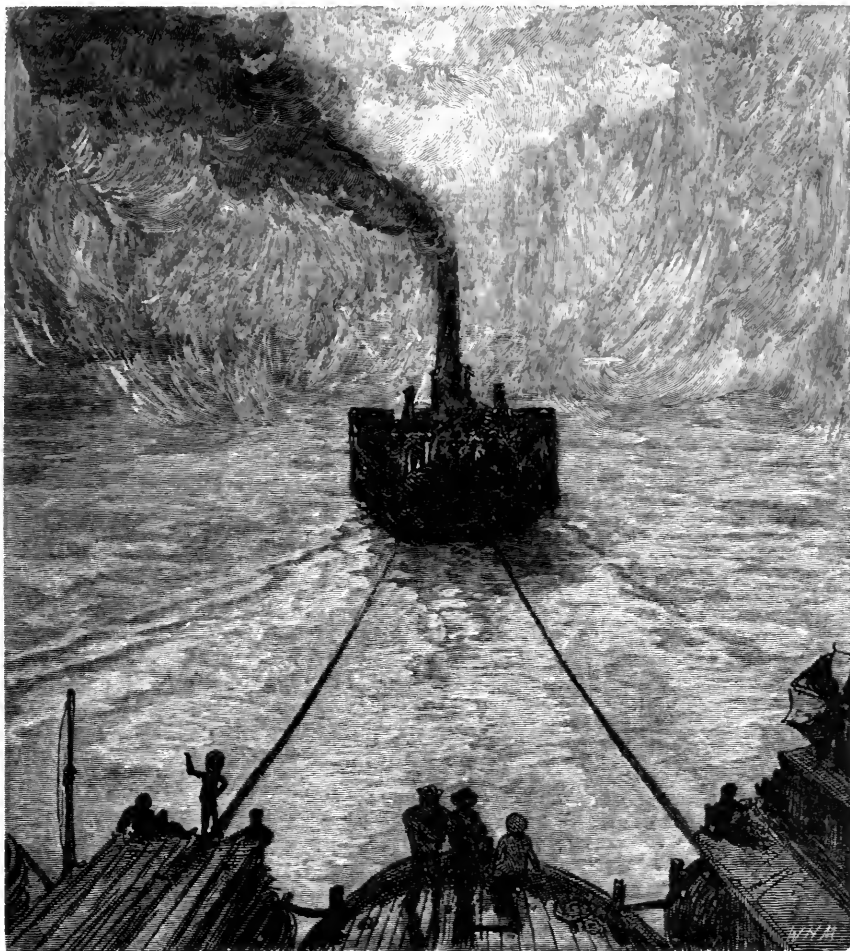

IN THE MIST OF THE EARLY MORNING.

DURING the winter of 1878-9 the Tile Club prospered. The expedition of the preceding summer, duly chronicled in these pages (see SCRIBNER for January and February, 1879), had resulted in much artistic

VOL. XIX.—45.

and other profit, and collectively and individually the Club was conscious of an agreeable progress. It had its bereavements in the departure of three of its members, the Grasshopper, the Gaul, and the Chestnut.

[Copyright, 1880, by Scribner & Co. All rights reserved.]

but it took to itself in their places the Ter-rapin, the Scratch, and the Pie, able gentlemen, who afforded it much consolation. The Gaul retired to a lonely island in the British channel; the Grasshopper, to remote Bombay; while the Chestnut took a studio in London, in the thick of the Royal Academicians, whence he sounds occasional notes of artistic triumph, and decorates his letters to the Club with sketches indicative of his sentiments in exile. The Wednesday evenings of the season were as merry as they were frugal, and were marked by a surpris-

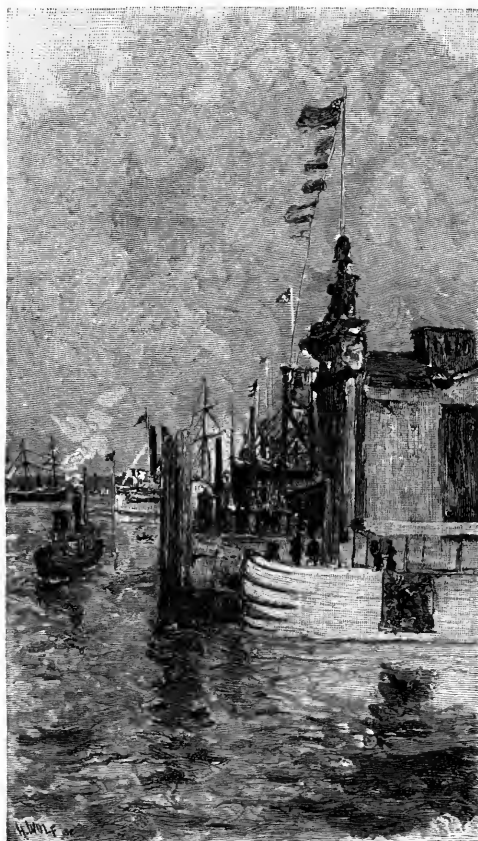

AT THE DOCK, FOOT OF WEST TENTH ST.

ing degree of industry. Few tiles were painted, chiefly because each member was already in possession of numerous assorted mantel-pieces. Plaques were therefore substituted, and many, varied and remarkable were the decorations.

As the winter passed there was evinced a deep concern as to what the Club should do in the way of a summer expedition; and various were the schemes proposed. The

previous success having been attained on land, water entered largely into all the projects that were advanced, with a marked reservation (except on the part of the Marine) in favor of the calmer variety. It was proposed to hire a schooner, and explore Long Island Sound, in search of literary and artistic remains; but the undulating character of the Sound waters caused the idea to be rejected. The Jersey coast was repudiated on the score of insects, and the lakes, on the ground of remoteness and the unknown quantity of expense. A suggestion touching the navigable qualities of canals was feebly thrown out by the O'Donoghue, but was not received with any warmth; and several meetings went by in constantly increasing perplexity. Finally, one evening the Owl sat down in his place, with an expression on his countenance indicative of the agreeable possession of an idea; and, after spoiling a previously deserving tile, he said:

"Boys, I know what we'll do next summer."

"You do!" said the Club; "out with it!"

"We'll hire a canal-boat, and go up the Erie Canal in her."

The O'Donoghue arose with a look of distinct injury and wrath combined.

"Which I wish you to understand," he said, with ill-assumed calmness, "that that idea is mine."

"Yours?" said the Owl, with haughty scorn.

"Yes, sir!" retorted the O'Donoghue, hotly.

"Your idea?" and there was a perceptible curl in the noble bird's beak.

"I'll leave it to the Club!" said the O'Donoghue, excitedly.

"And I'll leave it to the Club," said the Owl, "if you were ever known to own an idea."

And the Club sympathetically agreed that the probability was too strongly in the Owl's favor; whereupon the O'Donoghue withdrew within himself.

The Owl proceeded to unfold his plan; and, after the first blush of insanity had faded away from it, the club became deeply impressed with its practicability and attractiveness. During April and May, little else was thought of than the canal-boat, and how the proceedings should be conducted. To say that no two members agreed as to precisely what should be done is feebly to indicate the prevailing chaos of purpose. Ultimately, by virtue of the common exhaustion that

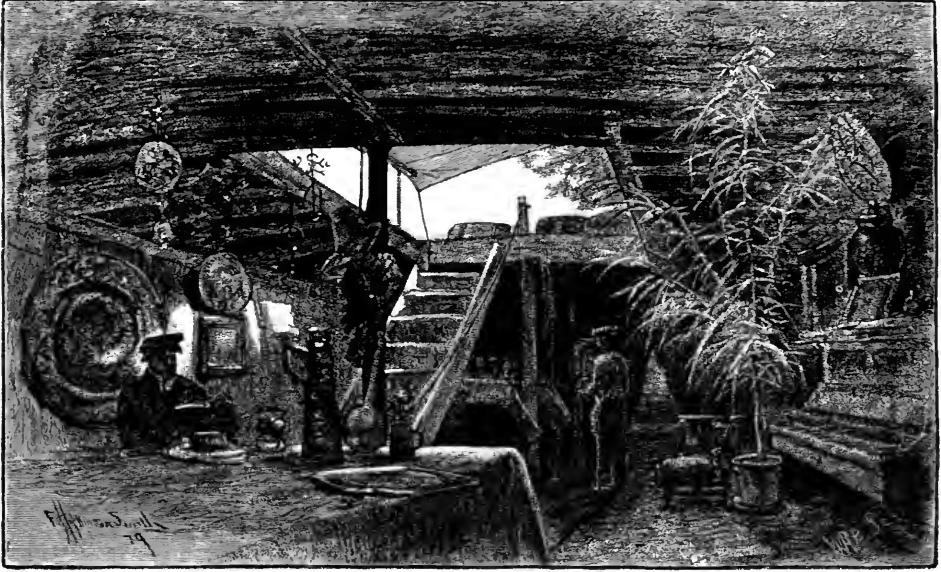

DECORATION OF THE SALON, 1879.

ensued, it was agreed to appoint a committee of two who should be held responsible for everything, and who could be bullied accordingly. They were.

The two upon whom this fate devolved were the Owl and Polyphemus, and the sufferings they underwent were harrowing. No other member showed the slightest confidence in their judgment. After passing whole days on the city front, or down at the foot of Whitehall street, exposed to the ridicule of scoffing and incredulous canal-boat captains and roustabouts, looked upon with detrimental suspicion by freight brokers, and pointed out to the police as proper subjects of scrutiny, they would be met with pointed satire and cold scorn of a Wednesday evening, when they attempted to report progress. They had probably inspected a hundred canal-boats that were too low in the ceiling, that had been carrying coal or fertilizers since the beginning of the century, that smelled of mules, that wouldn't go under bridges unless loaded, that had stables on board, or that otherwise wouldn't do. They had been ordered off as many more boats, by large women with washing-boards and other weapons, dogs had been set on them, men had exhorted them to speed and celerity of departure, and, at last, they had begun to despair, when fortune smiled upon them. They found in the dock at Whitehall street a new and neat-looking boat. There was no dog in sight, nothing more

formidable than a woman, who allowed them to come on board. A bluff, hearty, and well-favored navigator, fluently profane, and otherwise addicted to the conventional vices of his calling, came up at her summons from the cabin. The boat, he said, was new; she had made one trip with a cargo of grain, and was awaiting a charter. He didn't know about taking artists on a trip—didn't know what they were, or what they might be up to, and on the whole would prefer railroad iron or coal as a surer thing. He was amenable to reason, however, and he finally consented to charter the *John C. Earle* to the Tile Club, for a trip up the Northern Canal to Lake Champlain, for twenty days at seven dollars a day. Even then, when the fact was reported with some pardonable exultation to the Club, one ungracious member stood up and said he was not quite prepared to accept the committee's report; that he had had no evidence that the committee knew what a canal-boat was, and for his part he would like some proof that the committee hadn't hired a Cunarder. Black is the ingratitude, and blind the prejudice of the unworthy and the envious.

The next day all was bustle and activity among the Tilers. The *John C. Earle* was at the foot of East 10th street, in a fragrant dock. A new coat of paint was being put upon her deck, and Rossil, who carries all the freight of the studios, had his wagons going all day, collecting bric-à-brac, can-

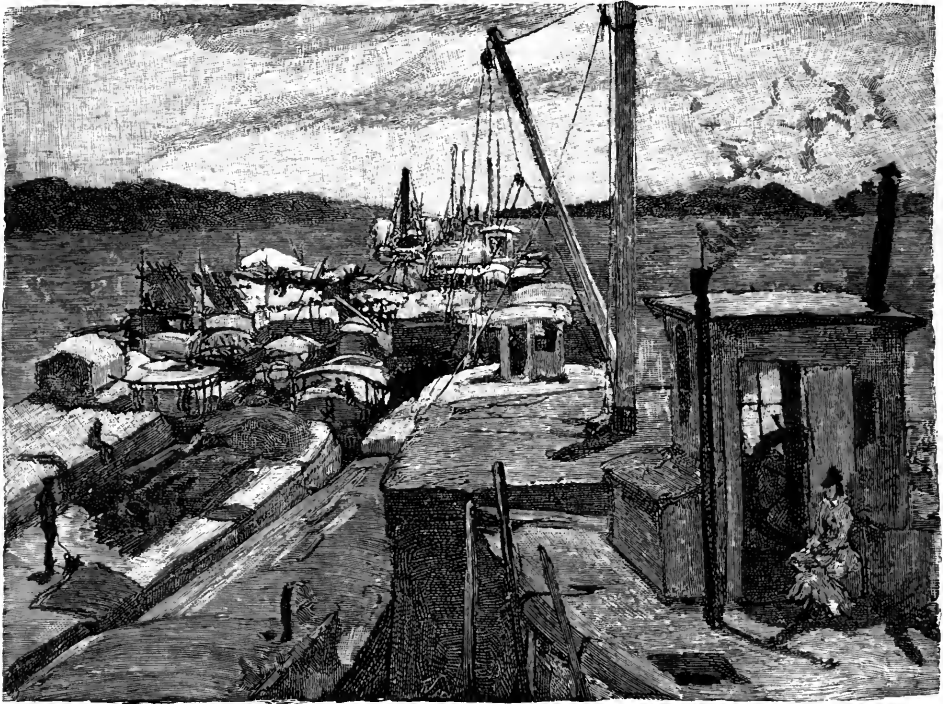

THE COMMUNITY AFLOAT.

vases, easels, draperies, costumes, paint-boxes, portfolios, and all manner of effects, domestic and personal. The Owl had had anxious interviews with colored gentlemen of a culinary turn, and had chosen one of promise, named Daniel, who was promptly commissioned to buy a large stove, and all the necessary utensils of his craft, and was given an unlimited order on Park & Tilford and the Washington Market. He came down to the boat with five tons of ice, a big refrigerator, a small cooking range, about one hundred paper parcels, two hundred pounds of fresh beef and mutton, neatly sewed up in bags to go inside the ice-house, quantities of vegetables, and two coops full of tiley chickens.

Daniel made a splendid impression. He was introduced to the Tilers, and saluted each one with an obeisance of true Oriental profundity and a smile that was a revelation of beneficence. He looked upon the wealth of color and rich trappings of the saloon without betraying the faintest trace of the plebeian emotion of surprise. It was even thought that his head was for a moment slightly deflected from the perpendicular and that one eye was partially closed.—actions which unfailingly imply the outward and visible physical phenomena of inward critical re-

flection. However, he gave no expression to his opinion, but betook him to arranging his kitchen and putting away his various stores. His kitchen inspired confidence, and his appearance, in a snowy linen cap and jacket and long white apron, was most re-assuring.

The Committee on Decoration and Home Comforts covered itself with glory. With unlimited bric-à-brac and tapestry, and stuffs oriental and domestic, at its disposal, the interior of the *John C. Earle* underwent an amazing transformation. If it erred at all, it was in the direction of positive luxury; but the artistic and decorative effect that was produced was excellent. To those who looked at it for the first time and from the point of view of having to dwell in it for the ensuing three weeks, it was particularly grateful. The divans, that were easily translated into beds; the cushions, that were but pretexts for the diurnal concealment of pillows; the piano, the violins, the big dining-table, the arm-chairs and hammocks, the neat pile of fresh table-cloths and napkins, the excellent glassware on the sideboard, the decency of the cutlery, the neat student-lamps and Chinese lanterns, and a certain grace in the profusion and a quality of ease in the general disposition, were extremely alluring.

The day of the departure was June 23d, 1879. The last valise was on board; there was a general sense of nothing forgotten, and there was a curious and unappeasable multitude. It was evening when a small parasite of a tug-boat came alongside the *John C. Earle* and towed her to the comparative privacy of the outer river. Great apprehension had been felt that the cabin of the boat would be insufferably hot; but

community of boats that was to compose the tow of the Schuyler Line was being drilled into order and lashed together, and it was late when the *Earle* fell into its place. Then, with prodigious bustle and noise and confusion, the procession began to move northward at a snail's pace. The city crept slowly by, darkness descended on the waters, the lights on the shore came out one by one, and everybody went below.

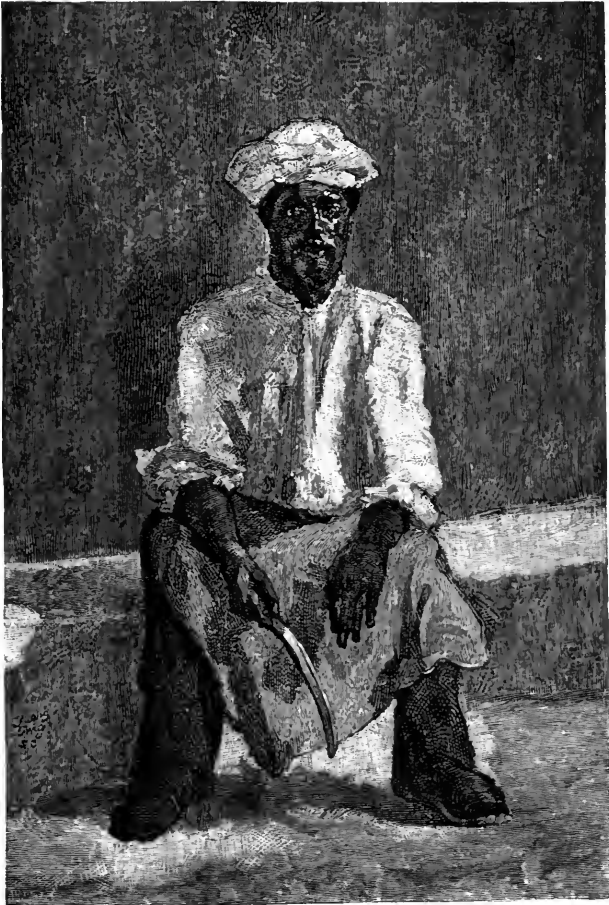

DANIEL IN THE TILERS' DEN.

no sooner was she in motion on the river than a delicious draft of cool air entered at the forward hatch and swept through the room from end to end, producing a most agreeable temperature. Hot as the weather subsequently was, the cabin was always pleasant, and upon no evening during the trip was it desirable to sleep without more or less covering, or without partially closing the hatches. Down about the Battery, the

Seated on a box, solemnly and perfunctorily polishing a silver pitcher, was a colored gentleman of indefinite age. He was as black as original sin, and his countenance bore an impress of serious, half-resentful gravity. He polished away in stolid unconsciousness, and the Club stared at him in amazement. The Owl was on the point of throwing an idol at him, by way of a beginning, when Daniel pushed aside the crimson



damask curtain which mitigated the entrance to the kitchen, entered, and took in the situation at a glance. He explained that he had been obliged to employ him as an assistant; that his mother recommended him as a good, honest and industrious boy, and he hoped the gentlemen would be pleased with him. He was christened Deuteronomy on the spot, and he entered impassively on the eventful period of his servitude. He was the slowest, laziest, and most imperturbable of his kind. He never walked, he crawled; and when any one called him, he never thought of replying until the summons had been two or three times repeated. It was pathetic to hear, of mornings, the sonorous period of his name ring out from some waking Tiler, and to note the resounding impact of the swiftly projected boot as it sought the torpid knave. Deuteronomy never dodged these missiles—he blinked his eyes and was indifferent. He furnished both excitement and exercise, and the Club grew greatly attached to him.

It was after nine o'clock before the Club became aware that it was hungry, and Daniel appeared and made a deprecatory little speech about the *cuisine*, as he and

Deuteronomy laid the table. Things, he said, were not quite in working order yet, and the supper, he feared, would be rather plain. The Terrapin was sitting on the floor, slicing cucumbers, which he had found in the ice-house. He made a salad of great virtue in a huge yellow bowl, and the Club sat down with restraint and expectancy in its eye. Daniel brought on a most fragrant repast, which atoned amply for the forgotten dinner. There were porterhouse steaks, done to a turn, deviled kidneys, cold roast beef, roast potatoes, hot biscuits, fried chicken (after the fashion of Daniel's native city, Baltimore), tea, coffee, and the Club's regular beverage. The quantity seemed unlimited, but in the conversational pause that ensued, the consumption that took place was nothing short of marvelous. Even the salad, composed as it was of cucumbers, had no terrors for them. Daniel smiled the capacious smile of his race, as he saw and heard the compliments to his skill. As the faculty of speech began to be fully restored, it became apparent that the Club was already perfectly at home; the last doubt that might have existed was banished, and all were convinced that the conditions essential to comfort and practicability were present. The Owl, who had eaten more and faster than any one else, surveyed the denuded platters and expressed his conviction that the provisions

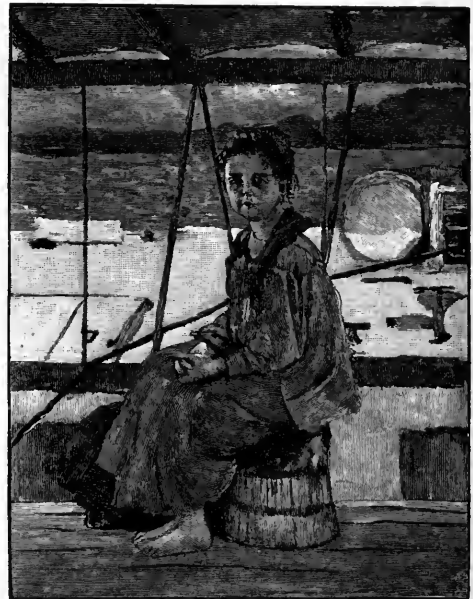

A DAUGHTER OF THE TOW.

wouldn't last half the voyage. Sirius said he didn't care: while farmers had hen-roosts, and the barn-yards contained small pigs, the Club should have the necessities if not the luxuries of life. No one was alarmed; the sentiment of the occasion was of the *carpe diem* order and the members reclined in their arm-chairs, and sent long wreaths of smoke out of the hatches, while they surveyed with untiring eyes the handsome cabin of the *John C. Earle*.

Later, when there was music by the Catgut, the Horsehair, and the Marine, curious mariners came from all parts of the tow, till both hatchways were fringed with faces that denoted all sorts of emotions. They asked if it was a new-fangled circus or some sort of a traveling theater show, how much it cost to go in, and where was to be the first stand. On being invited they came down with all the eagerness imaginable, and looked at everything with childish amazement and curiosity. It was a very jolly evening, and perhaps the proudest man was the captain of the *John C. Earle*, who imparted his ideas of his cargo to numerous inquirers. He wasn't freighting; not much. First class passenger business was what he had turned his attention to, this time; and such passengers! He gave the Club an excellent character, and the interest excited was of the warmest.

It was after midnight when the pipes and lamps went out by common consent, and the Club retired in great comfort. Conversation dwindled in the darkness and passed by an easy transition into inarticulate but familiar utterance, and the Tile Club slept the sleep of the just and of them that incline not to dyspepsia—all save the O'Donoghue, who prowled wakeful about the deck, like some Hibernian Palinurus, and bayed plaintive measures at the rising moon. He was nothing if not decorative, and his ambition was bounded by the art of the potter and the possibilities of the vitrifying oven. "When I am dead," he said, "they shall fire these my remains." And in the pride of his knowledge and the consciousness of his devotion to art, he wrapped about him the mantle of his private superiority and withdrew into the agreeable seclusion of himself, where the merely human never trespassed.

The gray mist had stolen down between the hills during the night and hung low upon the river. Nothing was visible around but the still water melting into the soft cloud, and nothing was to be heard but the

gentle ripple of the current eddying between the boats. The steamer ahead seemed to toil wearily to enter the mist where the struggling sunbeams made it brightest, and now and then her outline dimmed as the vague wraiths rose from the water's surface around her.

The community of the tow slept late when on the river, in order to make up for early rising on the tow-path. It was half-past five when the Owl, who had risen at dawn, sounded an original *réveille* with a mallet on a huge Japanese bronze bell that hung at the bow. There was no sleeping afterward, and the Tile men unwillingly abandoned their cool and pleasant couches.

A veil, or rather a canvas awning, must be drawn over the ablutions that ensued, performed as they were with vigor and reciprocal buckets, dipped from the Hudson with a rope. When the awning was replaced, the sun had dissipated the mist, the Tile men were dressed and clean; they sat on deck in the delightful breeze, sipped their coffee, and discussed the scenery of Haverstraw Bay, while waiting for breakfast. For this there was an excellent appetite. Daniel executed a wonderful omelette, the rolls were delicious, the rashers crisp and savory, and all the odds and ends in keeping.

Moving up the Hudson on such a perfect day in June, at a speed hardly appreciable, and under conditions so restful and conducive to physical and mental ease, the occasion easily lent itself to open-eyed dreaming. Two or three got up their easels and umbrellas, and wandered over the tow to make sketches, to the great edification of the community which crowded about with endless curiosity; but, for the most part, the day was spent in swinging in hammocks beneath the awning, smoking listlessly in the reclining camp chairs, and indolently admiring the beauty of the ever-changing scene. There were satirical discussions of the Hudson River School of Art and the work of its members, and of the good old mossy, geographical landscapes which used to crowd the holy precincts of the National Academy. The Pie delivered a little address on the alleged cause of art-critics, their superfluity and possible extirpation. But with the noonday heat discussion died out; the bold mountain-sides went by unheeded and the general drowse was with difficulty dispelled by the luncheon bell.

In the afternoon numerous bits of the tow and general aspects of it received attention, and later there ensued atmospheric effects of great beauty and sublimity. Even the

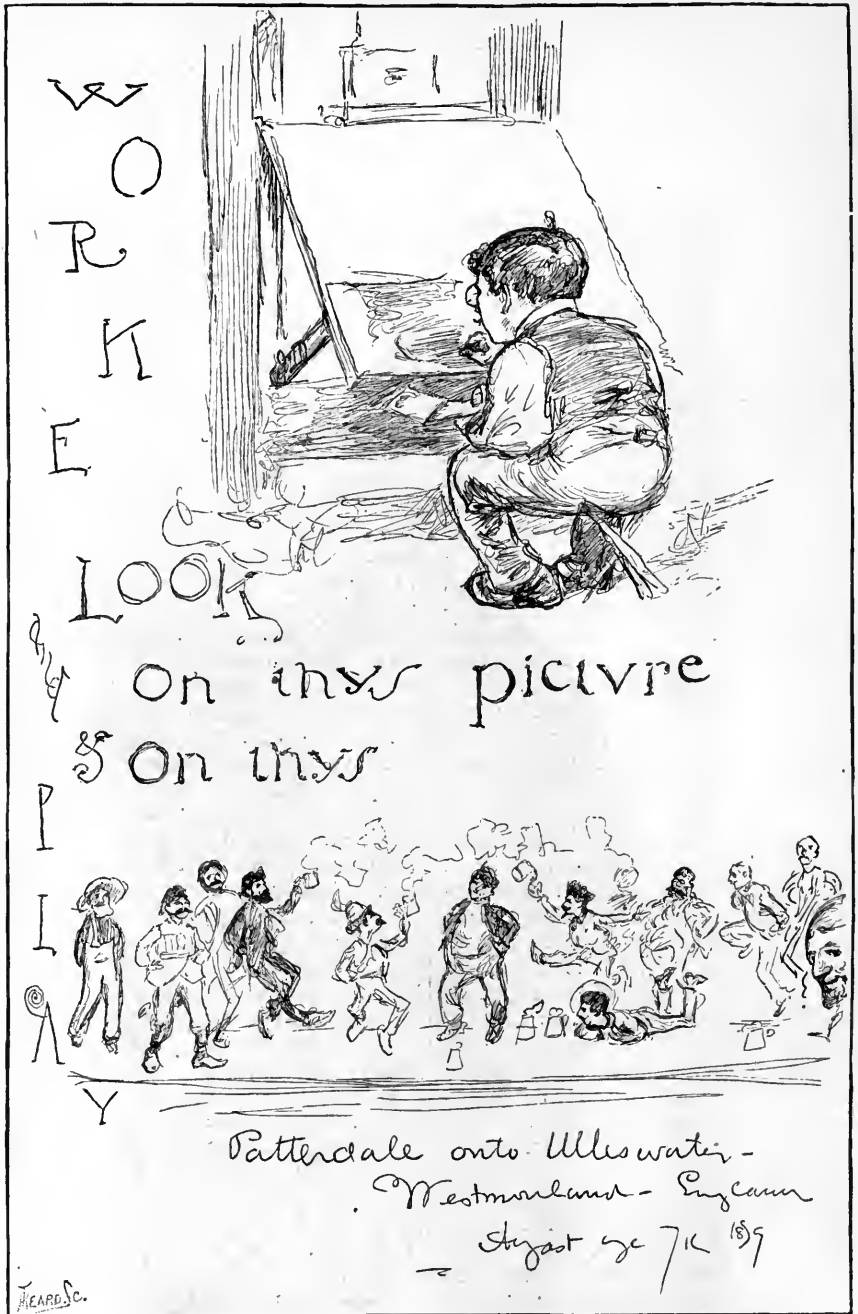

REFLECTIONS OF AN ABSENT TILER.

usual sportiveness of the Tiler gave way before the genuine enthusiasm of the artist.

"In wrestling with this Hudson river business," said the Griffin, "American art has been badly thrown. I think that nine-tenths of our backwardness has been due

to the overwhelming embarrassment of picturesque material that has all along been at our very door—material which, by reason of its grandeur and sublimity, in no sort of fashion would do to make pictures of. Simplicity alone has evaded us all along."

That evening, after a most excellent dinner, the Tilers compared sketches, and sat about the cabin and made music with a sense of having been out at least a week—so thoroughly at home did each man feel.

On the following afternoon there was a

made fast to a remote West Trojan wharf. Next morning, some supplies were purchased, additional ice was laid in, and, on consultation with Daniel, it was decided to hire a colored gentleman to wait upon the table, attend to the cabin generally, and, in



PRIAM, THE NUBIAN GANYMEDE.

thunder-storm; and in the cool and delightful evening that ensued, Albany came in sight, and a tug separated the 'Tilers' boat from the tow, and bore her off at a comparatively tremendous rate of speed, to Troy. It was nearly midnight when the captain

a measure, confer upon Deuteronomy the advantages of a sinecure. To all intents and purposes, the O'Donoghue had adopted that luckless wight exclusively as a body-servant. Daniel found a Scæan gate; and after an hour in Troy, returned with a pre-

possessing young man, dignified, sedate, and clean, and willing to enter the service of the Tilers, for a suitable consideration. He was engaged, and was thereafter known as Priam; and when, later, he learned what were the pangs of artists' models, in attitudes sustained, he showed qualities of mind and person that were not unworthy of the distinguished name he bore.

It was at West Troy, from amongst crowds of roustabouts in leather aprons, and small boys fringing the string-pieces of wharves with bare and muddy legs, that little Jessie Miller emerged, like sun from vapor. Invited to try the piano, she introduced her slender ankles through the hatchway, descended the tapestried stairs, and was quickly seated at the instrument, which, accustomed hitherto to Chopin and Beethoven, gave a few astonished discords, and then bleated obediently. The tourist who was etching, the tourist who was stringing a violin, the tourist who was reading Musset's "Rolla," looked up and liked it. Jessie had a host of little lovers, who swung their beaded toes from the opening of the hatch, when discouraged from coming further, and, when exasperated by her rigors, fought. Her eye glanced calmly at them, dangling around the square of the hatch above, as she pursued the thread of her melody. Soon a lad, to whom she had mercilessly recommended ablution, as she crushed him in descending, darted off like a stage bandit, seemingly to report Jessie's truancy at the maternal wash-tub; for a more loyal admirer shouted out:

"Oh, Psychsy, here's a boy goin' to tell on Jessie Miller for fun!"

But she needed no champion; just interrupting her song sufficiently to exclaim:

"Go on, Runty Pebbles; I know where you hid father's scullin' oar!"—she brought her defamer to a dismayed stop; and immediately, with unruffled greatness of soul, resumed her soft invitations to the company to meet her on a conjectural beautiful shore, at the maturity of those uncertain kalends known as the sweet by and by.

At Troy, the great Erie Canal parts from the Northern Canal, the latter pursuing a direct parallel of longitude, toward Lake Champlain. DeWitt Clinton's classical constructions elicited the artistic approval—the cyclopean lock-masonry, the weighing-stations of the American ultra-classic period, with pediment, Doric columns, abacus, and wreaths of laurel under the cornice. They had the *cachet*, it was admitted. The team of mules, being attached, soon quitted the

left bank, crossed two bridges, and proceeded up the east bank, bumping off the head of a statue or two by way of settling the floating studio in its new way. Incontinently, and while the leather-aproned lumber loaders are yet cheering the departure, a Cromwellian clock is laid over on its face. Bell boweth down, Nebo stoopeth, and a terra-cotta nymph of Clodion's is eternally divorced from the importunate Cupid who pursues her.

So far the journey had been delightful; but there had been something prosaic and commonplace about the motive power involved. It was therefore with a sense of positive exultation, on this afternoon, that the Club experienced the first impulse of the pair of sturdy mules, and felt a thrill of pleasure at realizing the true poetry of motion that the humble and misunderstood tow-path confers. Out of West Troy the *John C. Earle* glided with the stately bearing of a swan; out into the open country, among the beautiful lowlands, amidst scenery the most enchanting and simple, away from the smoke and the chimneys, the steamers and the tugs, the bustle and the industry of the busy river and the tireless railroads. The Club felt a new sensation; it was as if the expedition had had a new and better beginning—as if what had preceded had been a condition of probation, of which this was the reward, and that now only was the real enjoyment to commence. It abandoned itself to circumstances, threw all the cares and responsibilities of life upon Daniel and Deuteronomy, made Priam the custodian of its bric-à-brac, and plunged headlong into Arcadia.

Some great willows at a bend in the canal seemed most inviting. There was a quiet farm-house among them, and at sunset the boat glided under their overhanging branches and found a temporary resting-place in Weaver's Basin. Here the boat was tied up, and before long the deep grass among the willows—which ought to have been mowed, but wasn't—broke out with easels; also with a wash-tub, introduced by the captain's wife, who executed some vigorous aquarelles. The willows themselves became decoratively ambitious, and every morning dropped a veil of shadow-lace upon the awning. The artists took the hint, and by simply tracing the shadows, secured for their pavilion a system of ornament superior to anything designed by William Morris. The musical members of the party developed horribly; those who had before been simple *virtuosi* were seized with the itch of com-

posing, and all the agonies of experimental counterpoint groaned through the studio. It is but justice to the Barytone, however, to say that he did not yield to this uneasy mania. His thunder was modest and took the good old paths, confining itself to other men's compositions. Perhaps it was the contrast, but his morning ballads under the willow-patterned canopy seemed to his friends better than usual; even the composing lunatics dropped their dismal originality to lend him an accompaniment.

"I don't quite like your use of that diminished seventh," said Polyphemus from above, projecting his head over the combing of the hatchway as he reposed prone upon the deck.

"No?" said the Horsehair, with concern: "I thought I effected the gradation very nicely!" and he tried it again. "Isn't that right?" he asked in great perplexity.

"Well," said Polyphemus, disposing himself for sleep, "if you'll tell me what the dickens a diminished seventh is, I'll try and

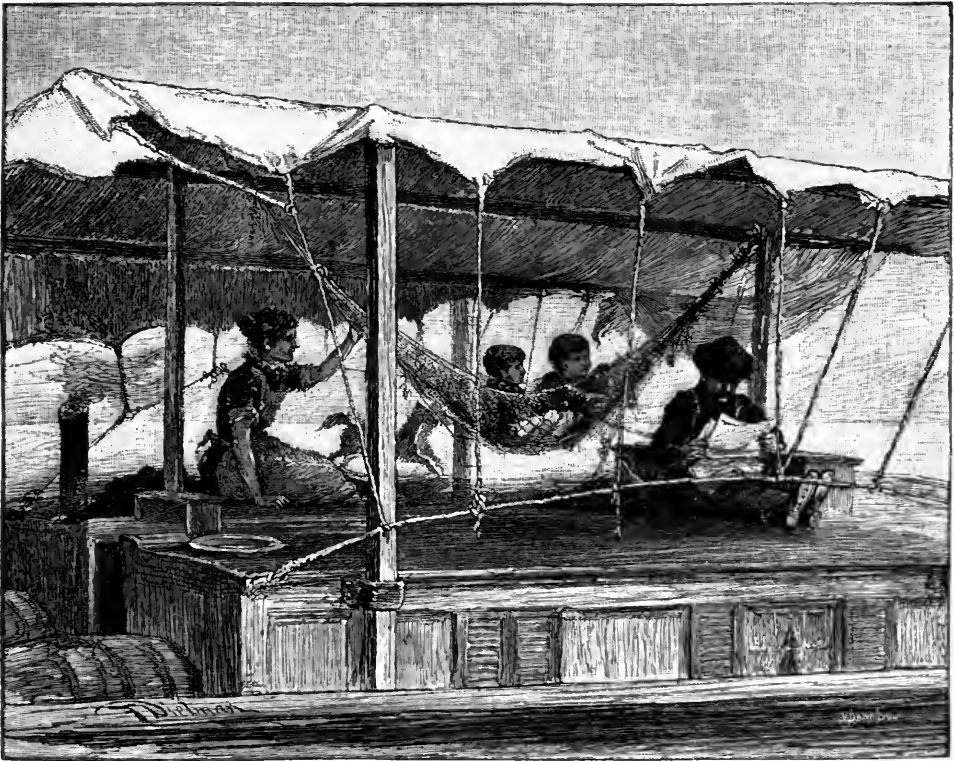

THE HOME CIRCLE.

Down in the cabin, one day of peace, the estimable Horsehair was seated at the piano with a small table at his right, composing a little romanza of his own fancy. The Tilers were away in the fields, the Captain snored on the roof of the cabin, Daniel was at the silent industries of his kitchen, and in the willows that overarched the boat was the sleep-compelling drone of a myriad life. The worthy Horsehair was immersed in his theory and harmony, but after a while he put aside the fragmentary experimental, placed his paper before him, and played a pretty movement with a distinct idea in it.

let you know. Of such," he murmured, "is indeed art criticism!"

The utmost revenge taken by the well-bred Horsehair was to criticise the artist members in terms of his profession, in turn rallying the figure-painter, the sculptor, and the copyist from nature, on the shamelessness of their embroidering.

The days here were hot and laborious. The Owl painted the willows, Sirius reproduced the passing canal-teams, the Griffin, with a sliver of charcoal, harvested the rank meadow-grass, and Catgut, constituted major-domo, overlooked the chickens, which

had moped and assumed catalepsy when cooped on deck, but which, turned into clover, instantly cackled and took to fighting. The nights brought a balm of rest, a

velop itself as an etching does." This from the Owl, who has sketched the studio in charcoal.

"Have you seen the new graphite pen-



POSING ON DECK.

forbiddance of cares. It was prime to insult the country by sitting up till one o'clock!

"We are innocent," said Polyphemus, "but we are not milksops."

The mammoth Chinese lantern was lit at dusk, and hung from the ridge-pole of the canopy, as big as the nimbus around a saint in a Gothic window; systems and satellites of little Japanese paper lights surrounded it, and defined the outline of the deck, while the darkling trees grew and towered to immense heights above. In the studio beneath decks, there would be the rival groups—the group around the long table, with the perspective of student-lamps, and abundance of paint-boxes, paper-blocks, and the like; and the group around the piano-candles. At such times the conversation would be professional.

"The objection that has always been made to charcoal is, that though it is velvety, it is nothing but surface; you get all there is of it at once; you can't live with a charcoal opposite your bed—it doesn't de-

vil?" asks the Hawk, producing an object like a carpenter's marker. (Sensation, and grouping of heads around the prize.) "The prejudice that has stuck to point is, that it is a little mealy and thin. But here is a point that opens up infinity."

"Rubinstein always touched that note with his ring-finger," says a pianist, "but I can't get it so, I must play it with my nose, I believe. By the way, have you noticed the exquisite cry with which Phileas starts the canal-mules? It is D flat, isn't it?"

"No, it isn't. Try." And the piano, the 'cello, and many voices are exerted until the note is matched. Then the mule-cry becomes a dramatic gag among the company, and everybody is exercising the long diminuendo of its cadence. The slightest interruption, in such a company, is like the passage of a keeper through a menagerie, and evokes a chorus. Then the board of workers, settling back and bracing the table-edge with the points of its slippers, awakes to the fact that it needs refreshment. A never-failing joy was the

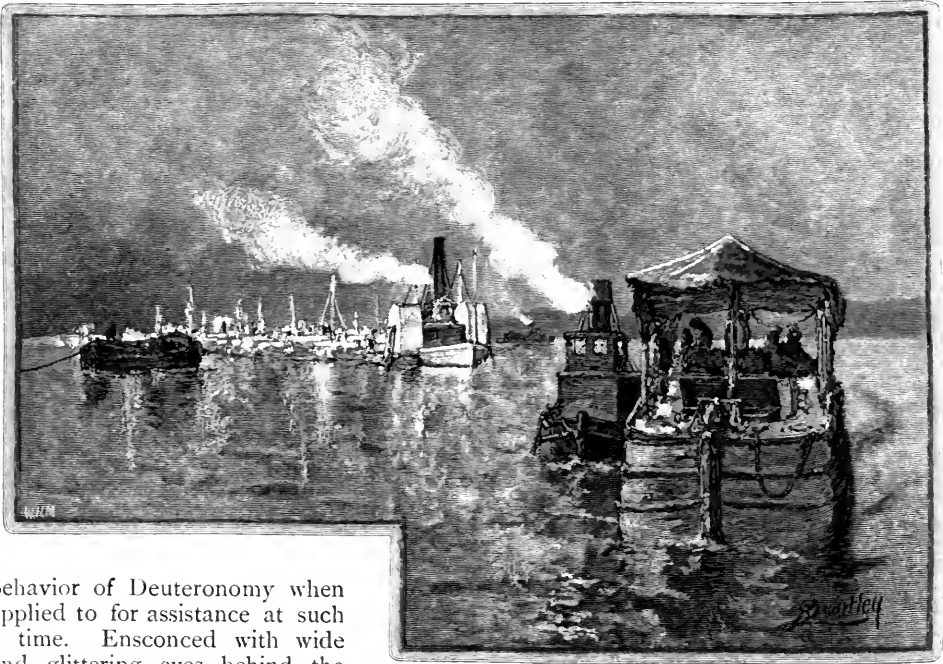

PARTING COMPANY WITH THE TOW AT WEST TROY.

behavior of Deuteronomy when applied to for assistance at such a time. Enscorced with wide and glittering eyes behind the water-cooler, so long as the talk was fragmentary and impersonal, this concentration of it upon himself had the narcotic power of plunging him into profound

and dense slumber. Stung by the improvised assegais of the company, Deuteronomy would learn that the most distant member desired, say, a measure of—ink, administered in a Flemish mug. It was fine to see him advance imperturbably through the legs of the party, as they braced the table, never on any account going behind. He would not give the least sign of seeing those impediments, but, with his glazed eye fixed on the furthest member, would precipitate his inertia through the line of locks thus opened and closed for his passage. Accompanied, preceded, and followed up by an elevation and a crash of human legs, fortified by philosophy and faith against the imminence of sprawling, Deuteronomy slouched and plowed his way with severity, always reducing to grave dumbness the persecutors who witnessed this sublime and tranquil penetration of matter

Meanwhile, the idlers on deck would watch the passing canal-teams, invisible on shore, but sharply defined in the reflections that walked patiently along upon their backs, trampling the mirrored stars.

In this region the tramp seems to have acquired his highest development. Not a morning but produced him in some new unimagined phase. There was one gloriously worthless fellow who wore the stump



JESSIE MILLER.

of his left arm in a mathematical instrument case. He had been with Livingstone on



A TOW-GIRL.

the Zambesi, or the Ngami, or something or other. This erudite person adapted himself to his audience—he had doubtless adapted himself to many. Exerting his faculties in the hope and direction of a treat of whisky, of which he was ultimately disappointed, he began to slander a certain modern explorer.

“He never got within three hundred mile of that river,—I met his own men coming back, and they reported fifty mile of bog on each side of it, and he writes that it was a hilly country.”

Noticing the boat-captain joining the circle on the grass, this astute nomad passing-ly remarked that he had been a canal-driver in early life.

“And a whaler, too, over yonder,” he added, with a circular gesture of the instrument case, vaguely indicating Willard’s Mountain, to the east. “I’ve thieved many a wounded whale from ships that was rotten and couldn’t defend their own. Oh, those pious New Bedford skippers! I could tell how some of ’em made their fortun’s.”

Upon this the New Bedford artist, furtively sketching

the visitor, was reviled by his companions—especially by the Virginia sculptor, looking up from modeling the tramp’s profile in beeswax.

“Good glory, they might as well have it as some of them dun-rotted Virginia slave-drivers!” observed the tramp, lazily rolling over into some deeper grass, and the Virginian was quenched in his turn.

There was even—whether you believe it or not—a fleeting female virtuoso. Accompanied by her boy she wandered through the fields with a flute, creating Arcady beneath her feet as she tramped. They stopped where the Marine was busy studying the other side of the canal, with those quick up-and-downs of his head as he compared his touches with their originals. The lad, a bright rascal of twelve, was hauling a little wagon filled with what seemed to be household effects done up in particularly small bundles.

“A handy method of getting your marketing home,” said the kind Marine (a family man), referring to this equipage.

“Augh,” she retorted, “it’s very little I’ve to do with marketing or home either.”

And pausing, she went off into one of those peculiarly Irish brown studies which the reader knows.

“What, you have no home?” said the artist, melted by the importunate thought of his own. “Then you are what the cold world brands as a tramp?”

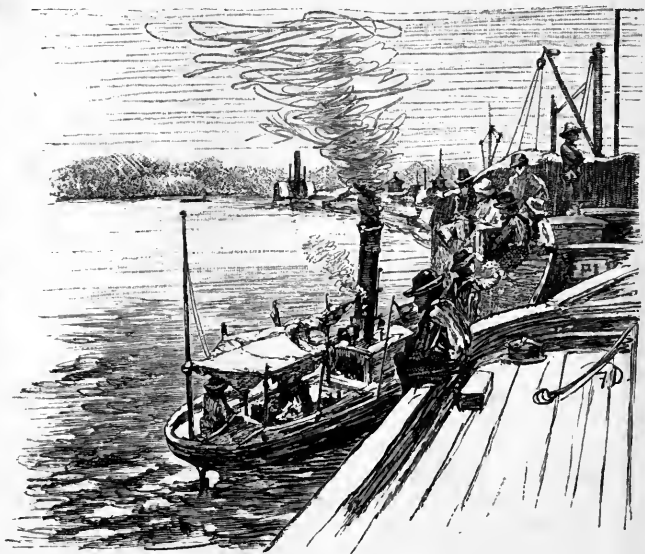

A VISIT FROM THE BUMBOAT, NEAR TROY.

In reply she cocked her eye raven-like, and crooned:

"But shall I go mourn for that, my dear?" with a hoarse approach to a tune.

"A philosopher and a scholar," mused

"Maybe; but what there is I make the best of!"

And she nonchalantly sat down on the bank to bathe her feet in the canal.

"It is a big foot-bath, you see. And

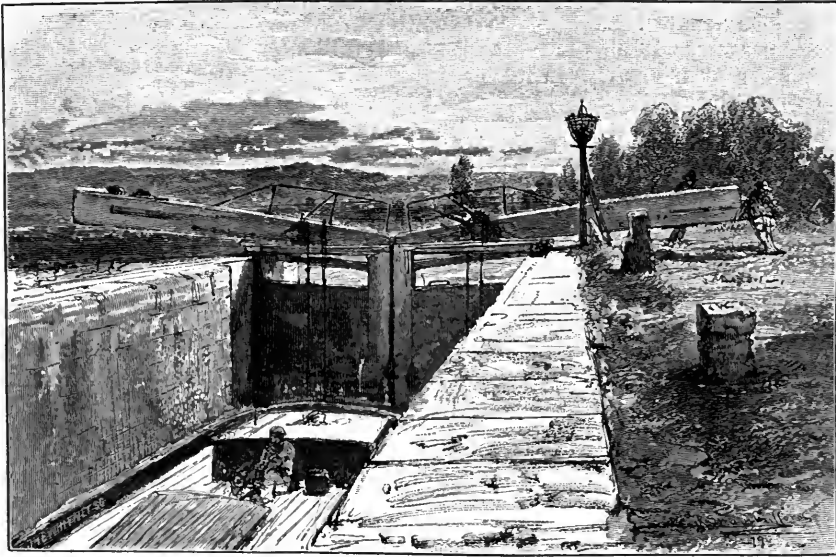

▲ LOCK NEAR TROY.

the Marine, regretting that he was not a figure painter.

"Enough of both to take things as they come," said this extraordinary mendicant, who picked up everything you said with a crow-like eye and an ever ready repartee.

"I'm hardly wise enough to like to do that myself," confessed the artist.

"It's little wisdom one wants that has no property."

"But you have not always been like this?" queried the man of family, stimulated to some pity by this jauntiness that sought no pity.

"My father was land-steward at Arrah Castle, and my husband's gone away with a better-tempered woman," confessed the philosopher.

"But he abused you first?"

"He was a fine form of a man. You're much like him."

"You ought to be glad of the riddance."

"But I'm a woman!"

Her quickness with this, and the look of her eye, were inimitable.

"And less of a philosopher than I thought."

that's a fine picture you're making. I know pictures. It's a copper-plate, and there was copper-plates at the Castle as plenty as wall-paper."

Until money, which the conversation melted out of the Marine, was offered, she held her special talent in reserve. Then, still sitting like Imogen or Musidora, and undoing one of the bundles in the little wagon, she produced an old, perfectly unvarnished flute which was carefully wrapped in waste cloths. "I wouldn't be taking your money for nothing," she observed, eying her solitary audience as she attached the pieces of the antique instrument. "I'm in the arts myself. I've heard my father play it at Arrah, and shook a foot myself with the lads on the green." The Marine looked up, his philologic interest awakened; a tramp who really spoke of "the green" was good as Goldsmith. "It's more 'an a hundred years old. Now, you see, this is the lark a-calling." And, still on the ground, she smiled into the flute with a flute-player's peculiar smile on her tanned face. "That's him a-calling to his mate, and this is the answer." Then came an assortment of the characteristic melodies

of Erin, which generally somehow find the heart, even when hoarsely delivered. "And that's the way that old Kerry Shelah and the boy earn a roof for their heads on the few nights they want one."

With which exposition of her business principles this footsore Thespian faded softly off into the dust of the tow-road.

A certain conscience of sloth, a sense that the mule of progress was all the while tugging at the line of duty, made even Weaver's Basin irksome at length. The Owl explained that, while violent delights have violent ends,

even lazy delights have ropes' ends. So the line was attached. The mules, much puzzled with their decorations of Spanish bridles and Japanese fans, stretched themselves to the task; the canal-boy drove them, and, having occupied the interval in incessant bathing, was demonstrably the cleanest mule-driver on the continent. The canal, ahead, was punctuated with little settlements, each named from a fort; and these old defensive terms strongly suggested the day when the stretch between Champlain and Hudson was no peaceful route for tourists, but a braid of Indian trails and military corduroys; and when the scattered colonists were called on to fight, first with the English against the French, and then with the French against the English, complicating their service with the slippery alliance of the redskins.

The fourth day of July came round punctually, as the tourists reached the historic fields of Saratoga. The artists wiped their faces, and explored the classic haunts, blazing with American glory and with Fahrenheit. The mayor and councils of Schuylerville, having visited the boat, having bathed their faculties in its artistic wealth, having exchanged some witty club-stories with its accomplished anecdotards, and wiped their appreciative beards over its hospitality, reciprocated these little attentions like men of sense. One enchanting morning their glossy Saratoga carriages wound down in a procession to the wharf. The Tilers included themselves in these conveyances, each of which had thoughtfully been furnished with a historic recollection, in the shape of an elderly and communicative native. Thus, with every advantage of company and elucidation, they trotted back, with smoking horses, into the midst of the eighteenth century.

As they went, the old epic movement recommenced, before their eyes, in the morning haze. What is this warlike pageant, passing before the black pines of Lake Champlain, in the dawn-fog? It is Burgoyne, with his Canadian army, his brigades accurately displacing one another, as he sets them down and takes them up at successive points of the shore, each advance quitting camp at the peep of dawn, and the flotilla scaring the morning birds as it sweeps its brigs and sloops and gun-boats behind the paper-bark toy-boats of the Indian fleet. Poor Burgoyne, the poetaster and wit, means to outdo the triumphs of his predecessors in the old French war. He thinks to



ART CRITICISM AT WEAVER'S BASIN.

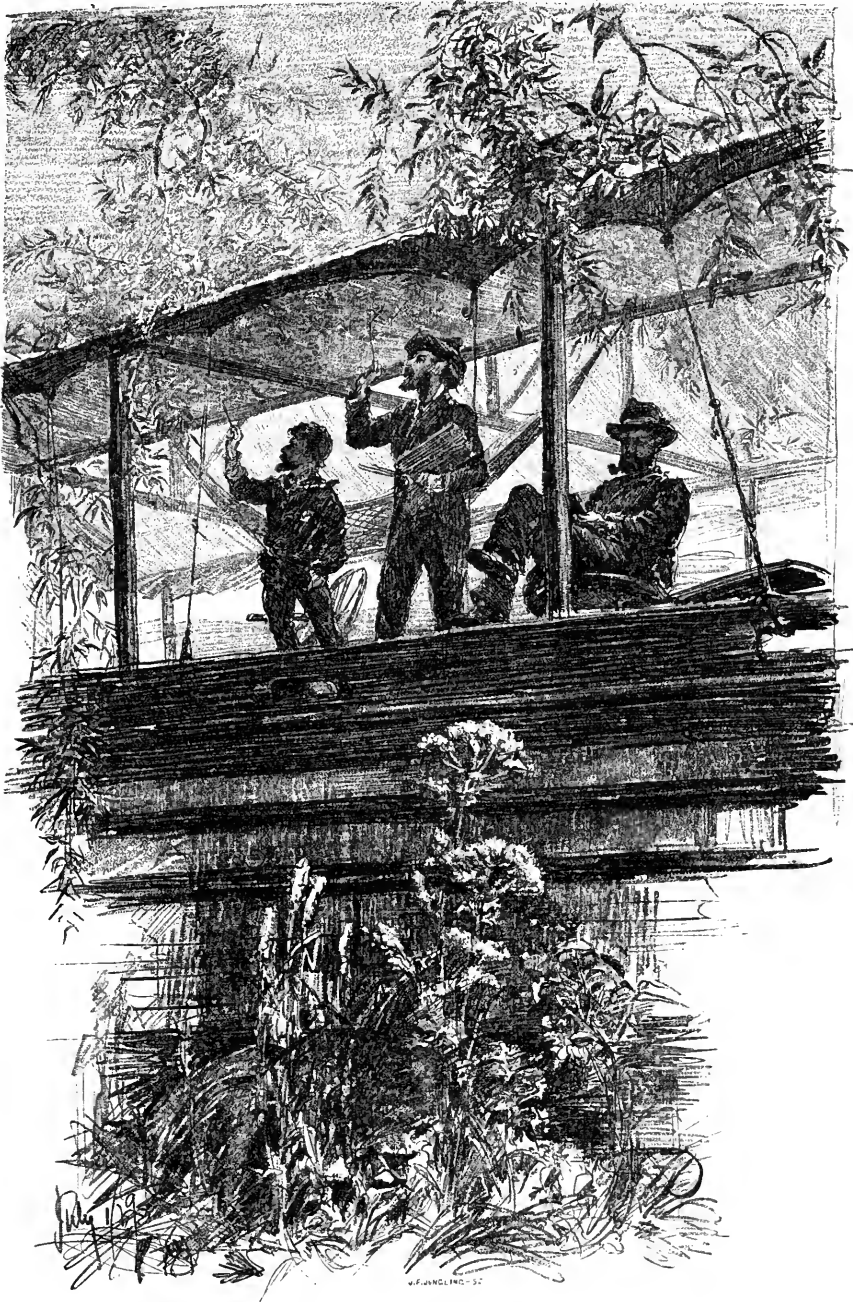

SHADOW-PAINTING.

repeat Wolfe's glories at Abraham's Heights, without his early death; or to earn again Amherst's emoluments for the capture of Ticonderoga and Niagara, in 1759, at which actions he had himself assisted. Gliding insensibly down the glossy stage of this

supreme theater, he thinks how Wolfe recited Gray's "Elegy," and couplets and tags of embryotic poetry dance in his head. Does he not wish his pretty wife were here, Earl Derby's daughter, whom he had wooed and won in a scapegrace elopement, years

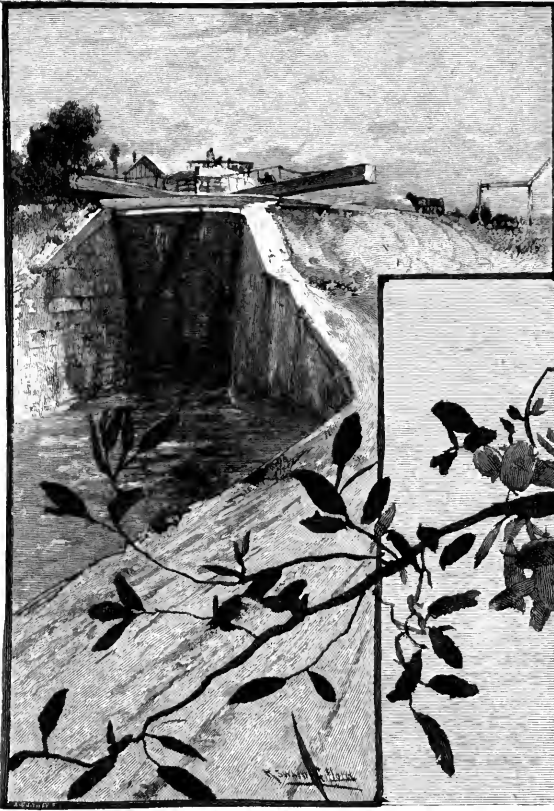

A DECORATIVE NOTION.

before? Could he not repeat to her copies of verse, not borrowed, like that pedant Wolfe's, but with the advantage of authorship—merry quips from his forthcoming comedy of the "Heiress," yet an unborn

creature of his brain—or, perhaps, with sweeter voice and tenderer intention, the beautiful numbers, to be used in his opera, "The Lord of the Manor," beginning, "Encompassed in an Angel's Frame"? These accomplished knights, descending on a lesson-teaching errand toward the American boobies, were high-strung, chivalrous, cultured, uxorious. Burgoyne dreams gallantly of his stolen bride, who shall wear the honors he is to win. The fair Hessian, Baroness Riedesel, is now flying from Quebec, on the wings of desire, to join her lover-like lord. The baroness' adventure, so long as it was free, was perilous; after it was fettered, among the American captors, it was tender, soothing, and romantic. This lovely lady becomes, in time, the Clio of the history. She is educated, observant, and genial. She watches the funeral of Frazer, who had died crying, "My poor wife!" and at whose interment chaplain Bredenell's prayer-book was incessantly made illegible with earth, scattered by the unconscious Yankee cannon balls. Lady Ackland, whom she calls the loveliest of women, shares

her housekeeping in the British camp, at Bemis Heights. Poor Ackland, fattest among the sons of England, had been shot in both his plump legs, and carried off by his friends in relays, first on the back of a faith-



UNDER THE WILLOWS.



THE MARINE.

ful officer, then on the shoulders of a sturdy grenadier, only to be plumped into the arms of the American captors by his last bearer, and to be nursed into health, in not into lerable captivity, by his tender wife. There were choice spirits, too, among the Hessians.

Riedesel's own rank and file include persons of education and refinement. There is the poet, Seume, conscripted from his studies in the Leipsic University; and there are the accounts of the German officers, such as the "Briefwechsel," where the campaigner makes fun of the respect shown by the American yeomen for the powdered wigs of the Colonial generals.

The visitors saw it all, through the diminishing end of destiny's field-glass: this pompous advance, and the unmitigated failure; this lofty European urbanity confounded before the bumpkins; this splendid, rolling battle-cloud dissolving its lightnings in prolonged discomfiture without a victory; Burgoyne's leg of mutton knocked by a cannon off his mess-table on the Fishkill; Mrs. Schuyler setting fire to her wheat-field lest Burgoyne should reap it; the British officers' favorite hunting-dogs pining in captivity along with the British officers' highly-connected wives; luckless Ackland set on fire by his pet pointer, who upset the candle in his tent, so that the major (whose weight became the repeated test of friendship) had to be carried out of the smoke by his sergeant; and then, desperately returning for his wife, was again stupefied and again carried out,—his portly form the perpetual equilibrium of his friends' regard for him.

The tourists were shown the still eloquent scenes of these events. The room in the old Neilson House, headquarters of the American generals, whither Lady Ackland was taken to nurse her fat and prostrate lord, still remains. In the mansion where for several nights Baroness Riedesel was bombarded by the Americans, the artists were shown

the cellars where the fugitive lady lived so long in terror; the Continentals kept up an industrious fire upon it, under the impression that it was the castle of the British generals, instead of the refuge of a gentle lady. In those basements the fair dame played the part of a veritable angel—a German angel. With one hand she made soups for the wounded who were brought in; with the other she covered the mouth of her screaming little Frederika, the child who safely grew up to be the Countess von Reden and the friend of Humboldt. In this sad cavern the recording stylus of history still shows its legible penmanship; the beam or rafter stretches near the cannon-ball that shattered it, above the floor on which the anxious mother counted the hours of the night, sitting on the ground with her children in her lap; and a sovereign of 1776, dug from the earth, perhaps a bit of the British gold that paid her Hessian husband, is exhibited, with the usual tomahawks and flint-locks of this sort of museum. Near by is the Schuyler Mansion, fabled to have

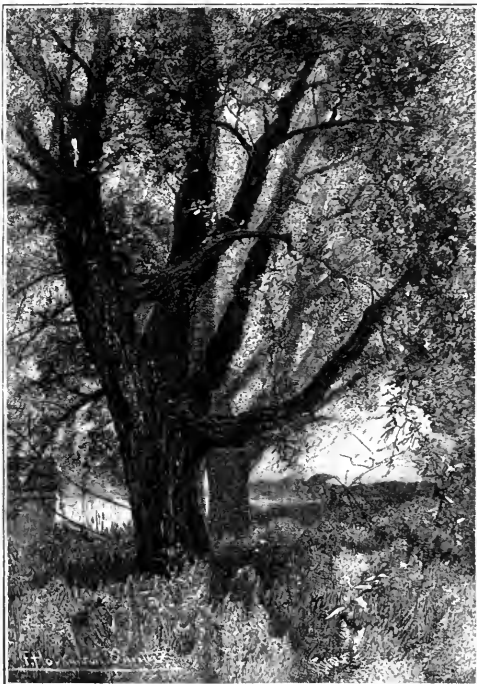

A PANG IN BLACK AND WHITE.

been rebuilt in seventeen days by Burgoyne, in reparation for his having fired the adjacent residence of General Schuyler while retreating. The General's fine old Dutch castle of 1610 was within a stone's throw, and an



ONLY PREPOSSESSING VIEW OF THE OWL.

abundance of the imported Holland bricks are still dug up from the grounds. An aged colonel, a pattern of old-school military etiquette, exhibited the beautiful centenarian of bricks and mortar; a confidential agent of General Schuyler's son, he had first managed the establishment and then purchased it, using it now as a shelter for his honored age. His charming daughter explained the curiosities of the rooms, then laughed and excavated some costumes and trinkets. When tired, she sank into a settle a hundred years old, threw a Queen Charlotte parasol

upon an Abercrombie chair, and said that if she didn't rub up the andirons soon they would look as old as the hills.

No finer flavor could well be found than the *ton* of some of the old town families, who here made the acquaintance of the canal-boat. Dating back to the Holland burghers of Rotterdam and the Hague, proud of the Vans and Tens in the family names, secluded from the metropolis, but sensitively conscious of Saratoga, the belles of these rural seats had more of the style of the delicious French country-house than is easily found elsewhere in our raw nation. They were cultured, rustic, innocently pleased, proud, and simple. They flocked into the boat, in the wee hours that followed a strawberry festival, and were vastly set up at the thought of being out after midnight; the vicinage of the traveling studio was an occasion and a pretext for unprecedented larks. They were waited on by beaux who for a fortnight had been waxing their moustaches, and keeping the brims of their silk hats in curl-papers for the Fourth of July. The maidens trooped through the barge, clothing themselves, as they went, with the choicest morsels of the artistic shop. There was a mandarin's crape robe, embroidered with silk puppies, which was an especial favorite; a young miss came out with innocent courage in the spoils of a Turco; Mongolian pagoda hats and Franz Hals ruffs were all one to these ambitious costumers, and nothing could be fairer than the blonde kappelmeister who touched the

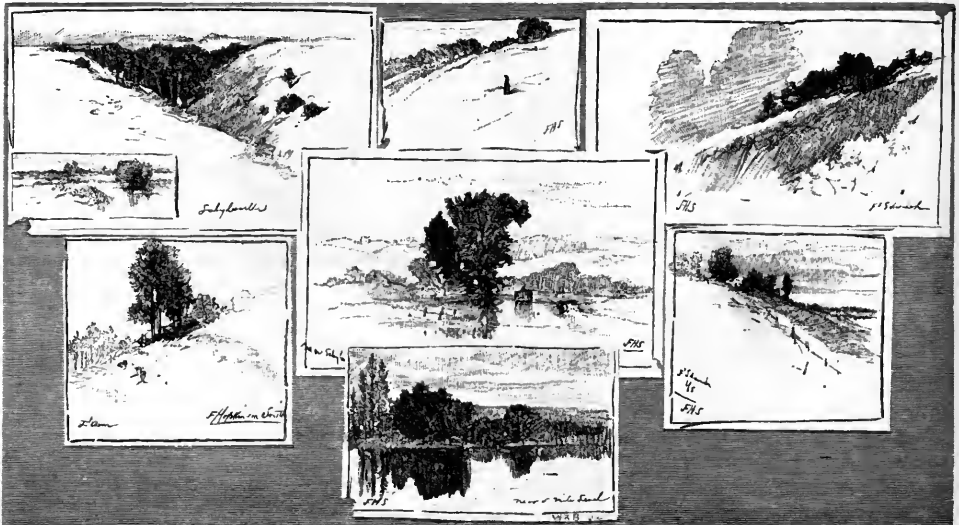

PROWLINGS OF THE OWL.

piano (in a Rembrandt toque and Vandyke collar) with notes of a Handel hymn, to which the words of "Yankee Doodle" were somehow found to fit to a marvel.

"I am content with the battle-field," the

had their mates but he. His friend answered him, as a friend should; "Cheer up, cheer up, cheer up, Sam, don't let your courage go down; there's many a belle, that I know well, is waiting for you in the town."



A BIT OF SCHUYLERVILLE.

Griffin was pleased to declare, well on towards morning. "Arnold distinguished himself here, and if he had had the luck to be shot by Frazer instead of shooting him, would have been a saint."

"I can't much pity the literary man," assented the O'Donoghue, alluding to Burgoyne. "His pen was mightier than his sword. He was to extend the triumphs of Quiberon and Quebec. It was only a little while after Horace Walpole had declared that he was forced to ask every morning what victory there was, for fear of missing one. Then Burgoyne went home, and took to writing farces. I like these compensations of a literary life."

"I like Miss Vandeneckhout better than Miss Tenkate-kateels," said the simple and gallant Cadmium. "Her hair is tawnier."

Meanwhile, on the wharf, two belated celebrants of the Fourth were vaguely heard consoling each other in musical snatches. One moaned that the fox and the hare, and the beaver and the bear, and the bird in the greenwood tree, and the pretty little rabbits so frisky in their habits—they all

The delightful contrast to these village orgies lay in the calm glide along the canal which would follow. There were many small towns to meet, and at each the kind inhabitants, long before advised of the coming of the Tilers, presented themselves with cunning gifts of flowers and fruits. Æsthetic teas became possible. The ladies in these places proved to possess an erudition in bric-à-brac surpassing all belief. As the fair processions coursed through the boat,—laying on their graceful shoulders, as they went, such Venetian or Eastern ornaments as caught their fancy—and as the musical members contributed a modest orchestral background or relief, it became a habit of some of the club to reel off a string of elucidations, as much in the style of the menagerie as possible. But it was very common for these officious explainers to be cut off by auditors better informed than themselves, or for their audacious inventions to be detected ignominiously. For instance:

"This trophy, ladies, exhibits halberts, yataghans, Algerian guns and pistols inlaid with turquoise, and the famous Greek



NICE GIRL IN AN OLD CHAIR.

arquebus which shoots round the corner. I picked it up, in fact, in the Corner palace in Venice. This little implement resembling a skeletonized hand, garnished with fingernails of lead, is the dreaded Russian knout —”

“Oh, I know,” the editor’s wife would exclaim (it was invariably an editor’s wife or a clergyman’s wife who thus wreaked

herself on interruption); “the boyar’s wife always presents it to her husband just before marriage, like a kind of engagement ring, and begs him not to spare her. And if you happened to be an editor’s wife, Maria, as I am, you would be flogged with it barefoot to Siberia every time your husband clipped one of Mark Twain’s jokes. And serve you right, *I think!*”

"This figure, ladies, is either a Hindoo idol or a Peruvian mummy, as is evident from its having lost its head; in our country it is the young man who loses his when

twenty feet across, Italian, and shows Nebuchadnezzar feeding among the beasts. There is a really interesting symbol connected with tapestry, ladies. The workman



SPIRIT OF A NORMANDY DAY.

he worships the idol. You smile, young ladies, so you know I am right. But the particular Tiler who adores this image is on deck, and I can't explain it properly. These wooden saints are from England, and were all knocked down by Cromwell in person, as is proved by the mutilations. They were knocked down to Polyphemus in Wardour street. The beauty of them is, that they have all been worshiped, like the heathen ones. The stuffed crocodile is in a mutilated condition, the owner's Chinese laundryman having devoured the most of it surreptitiously, as medicine. The tiger skins are tokens of our own prowess, the animals having been fought with incredible gallantry by a couple of us in Ann street."

No clown's jokes ever became the saw-dust better than these follies fitted the audience. It was "Oh lawk, Amelia, you can't see an inch of the sides, they're all broc'telle; and the floor is like Cousin Martha's matting, only with a diamond;" and "This in the frame is beautiful. I know, it is a water-color. And I can read the signature on it, Boldini. It is exactly like Frank Overton's wife paints on fans." But the snapper-up of unconsidered explanations was ever on the alert to fulfill her function.

"You have noticed the tapestries, ladies. That which curtains off the kitchen is a high-warp Presentation in the Temple, and Flemish. The one on the other side is

constructs them entirely from the back, and so he never sees——"

At that the local editor's wife—it was at —— that this happened—assumed an expression of real horror, and her countenance became livid.

"Oh, *don't* go into the tapestry-weaver and the reverses of the present life! Four times



DAMPNESS ON THE TOW-PATH.



A DIVERSION IN PAYNE'S GREY.

this very year, that is, I've heard Lucinda Haviland's husband say that in his pulpit. Only the last time was at our midsummer festival, and it seemed to make it worse."

But when the eloquence of the Tilers was baffled thus by a *contretemps*, they could easily turn to their other accomplishments. The Horsehair, in his ululations, and his piano-playing accomplice, had a reserve of classical morceaux that never failed to reduce the most voluble village belle to a state of idiocy. These ladies, who were always *virtuosi*, would innocently accept the invitation to listen to a little music. With criticisms adapted to the more specially didactic form of melody usual in small towns, they would begin to listen in a frame of condescension and blandness; but vague agonies would soon commence to shoot over their features as they found the scheme of the selection gradually eluding them, and before the duet was over they were ready to beg that their lives might be spared.

It was still better sport to study the evening audiences of town magnates—"squires," manufacturers, physicians—when the club were exchanging their ordinary dialect-jokes and stories. A premature party of these invited guests happened to come one evening before dinner was quite over, and when, the night coming on cold, it had been proposed to wrap up in the "costumes." So, too proud to doff their borrowed splendors, the club received their guests in the semblance of Veronese portraits, Mierevelt Lollards, brigand chiefs, mixed up with occasional Japanese Emperresses in moustaches. The picture will long remain glowing on the tile of memory

of how the magnates looked, plastered round the parallelogram of the cabin, each with a Flanders flagon on a plump knee, and receiving with awed seriousness the efforts made to entertain them, whether those entertainments consisted of Bayadere dances, or narratives of negro dialect,—whether Catgut imitated the bagpipe with his violin, or whether the Owl "mugged" at them in his richest style as "Misthress Rooney."

One of the visitors shaken upon their deck by accident's dice-box was of a more interesting and appealing character. Ever since leaving New York, as they moved up the gliding waters, good Mrs. Davenport, the captain's wife, had been talking of her old school-ma'am, Parson Miller's daughter, who had fallen down the scuttle-steps in one of



A SUCCESSFUL SKETCH.

the old Millerite "ascensions"—"and-her-back-had-to-be-sawed-in-two-gentlemen and tied, together, with, white, ribbons!!" Her friend would certainly visit the boat when it neared the proper village. And in due time the sufferer came. This lady proved to be a charming and modest recluse, of great age, wife of a Justice of the Peace; and she was actually the daughter of the famous first "Millerite." The portraitists of the Club caught fire. What an accession to their wardrobe of costumes would be a genuine ascension robe, if it could be procured! And now, if ever, was the chance. The ancient dame moved with difficulty down the padded stairs, guided by her friend. Then, to the astonishment of every one, after a little ordinary conversation, she noticed the 'cello leaning against the pile of music-books. "I taught myself to play that bass-viol when I was a maid," she observed. And soon she was actually tuning and managing the instrument, playing and singing "Come to the sunset tree," and other lyrics of a long-gone time. The artists noticed that she grasped the bow by the middle, like the viol-players of Fra Angelico. Her accomplishment was naturally her main topic, but she did not obtrude it, being, indeed, sufficiently pressed to exhibit herself. "I'm obleeged to you, young gentlemen, for your kind words, but I mustn't wear out my welcome. I'll give you one piece more. We was a large family, brothers mostly, and we all sung part songs, and all played a different instrument, and father loved to hear us. And this was a song father made to greet a clergyman who had left us, and lost 'most all his folks, and then come back. And we sat in the kitchen and sung this song to him, to the tune of 'Alknomook will never complain.' And he cried plentiful." Then she sung: "You're welcome, you're welcome, dear brother, at home, but where, tell us where, your Eliza is gone? She is low, she is low, in the dark, silent tomb, and her language is now, You must all meet me soon." It is difficult for the reader to realize the quaint charm of such an entertainment. The Tilers, except two or three who were furtively sketching, forgot their professional smartness, forgot to ask for the ascension robe, and the

musical contingent declared that there was a glamour about the thing that was better than music.

A Jesuitical Tiler was found to ask the Judge's wife, with a manner of profound



"AND THINGS ARE NOT WHAT THEY SEEM."

respect, whether she herself was an adherent of the paternal "Millerite" belief. Her answer was exquisitely simple and right. "I respected my father, but I didn't believe as far as he did. Young men, it's not for us to know the times and the seasons, not for us to know the times and the seasons." With this bit of augury, softly

crooned, the stooped figure crept to the steps and effected its ascension, and you may believe that not a Tiler smiled.

This serious conference, which had been heard attentively by the black assistants,



"COME TO THE SUNSET TREE."

was provocative of an interesting theological discussion next day among the acolytes of the chapel. The chapel, so called, was a dim corner of the saloon, draped with the Nebuchadnezzar tapestry and adorned with a large Spanish crucifix, which was flanked on one side by a gilded St. Roch, in his pilgrim garb; on the other by a corresponding St. Joseph. Madonnas of Gothic acerbity were rather abundant in this corner; there were several pendent Italian lamps, and there was a swinging thurible, usu-

ally hung before the Madonna, which it was the duty of Deuteronomy to keep burning with incense,—a task which, it need not be said, he neglected with fervent constancy. A dark and private corner, his habitual preference honored the chapel when he wished to rehearse the slumber of the just; and here was the dialogue held, over the insensible body of the lad, until he arose and joined the conversation with an awakener. The eaves-dropper who culled the colloquy did not catch it all, but reported it as something admirable and unique. It seemed that the waiter, a worldling of the Long Branch order, was being taken to task by the pious and conscientious cook. The former was expressing the most ghastly worldliness and time-service.

"What I knows, I knows. If one of dese gentlemen gives me dis two-shillin' piece, or maybe a dollah, I aint a-goin' to give it to Zion."

"But you get your interest a hundred fold," urged Daniel.

Upon this Deuteronomy straightened himself up. The scene was rather picturesque, for the tapers and swinging lamps were lighted, and the incense, for a wonder ignited, diffused its spicy fume in wide arcs.

"Now, you two men, jist listen to me," quoth Deuteronomy. "Hyar's the real church sign, that can't lie. Dis figure woved into de carpet hyar is Daniel, and he's a-pointin'. D'udder is Neb'chadnezzar, but he is out o' his head and we don't have to take no notice. Daniel is a-pointin', and it was Daniel counted de times and seasons, de good lady said. And now —"

They were in the habit of listening to the lad's monotonous drawl, which occasionally concealed a purpose. This time it did, for before his colleagues were aware he had neatly and without objection possessed himself of the half-dollar which the two arguers had produced between them, and, on pretense of consulting the oracle, dropped the whole into a rent just under the prophet's hand, whence it fell into a crevice known to Deuteronomy alone.

"When dat's return to you, it will be return a hund'ed fol'," he said, and the whites of his eyes fairly shone.

Through these conversations and incidents the barge moved insensibly forward, the unconscious motion interfering with no labor, yet gradually and magically shifting the external vision. None of the party had ever before experienced the charm of absolutely insensible movement, and as the world

slowly unrolled before their eyes, diorama-like, they pursued their professional avocations, undisturbed by the slightest jar, yet never in the same place for two moments. The Owl cultivated the art of short-hand sketching, and exhausted the scenery as he traversed it. If the region was artistically good and the Owl was invisible, the O'Donoghue would shout :

"Why isn't the Owl up here, pumping Nature?"

And, obedient to his mission, the sketcher would emerge, and desolate the whole country with his omnivorous talent. The range of incident was charming, half-aqueous, half-pastoral. In one place they came to a tile-works,—a veritable Tuileries,—and, as tilers should, made themselves at home. The kiln, the mill that ground the clay, the heaps of tubes like crimson macaroni, the boy that minded the fire, all were food for artistic reflection. And the proprietor, the image of a French mustache retired from the war on his "*terres*," reddened his broad

McCrea, whom the Indians scalped as she was trying to join her British soldier-lover; the poor man, one of Burgoyne's troops, died in deep melancholy, they say, caressing the tress of long and abundant hair, which he had recovered. At Fort Ann, where the keeper of the "wood lock" had a pretty little girl, the canal joined Wood Creek, of which it afterward became a mere development, until it emptied into Lake Champlain. Here was a poetic and artistic spread of country, low and sedgy, with real, "practicable" will-of-the-wisps dancing over the stagnant waters at night, of which the real, living canal-drivers are really and positively afraid, in 1879 and probably in 1880. Enchanting "business" for lookers-up of the picturesque! And here they saw the wrecked canal-boat, the *Evening Star*, ignominiously quenched in the twilight, with its heavenly protonym palpitating in the vapor above it.

And so, past all the legendary chain of old Anglo-French forts,—Fort Hardy, Fort

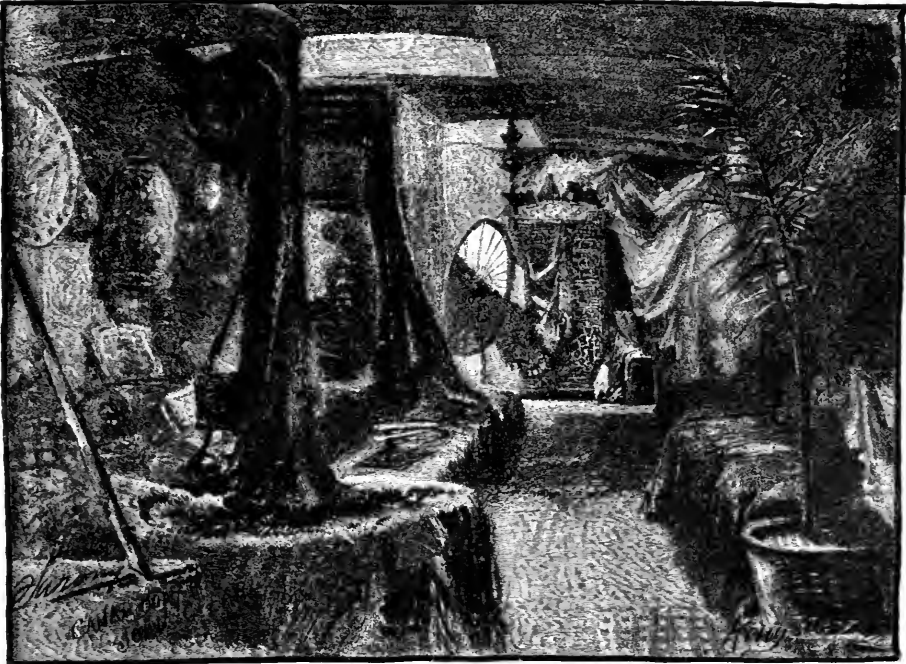

NORTH END OF SALON—1879.

face with an additional "fring," as he bore down upon the departing boat with an enormous pail of pure country milk. At Fort Edward, there was the grave-stone, chipped to a ruin by tourists, of pretty tory Jenny

Miller, Fort Edward, Fort Ann,—the Club debouched by the dull Wood Kill into the mirroring waters of Lake Champlain. The embouchure is at a quaint old place, a canal-boatman's paradise, known to our fathers

from the name of Skene, the tory half-pay major who secured royal grants of thirty thousand acres hereabouts for his loyalty—a title which, unfortunately for him, the Revolution reversed. This time-server of Burgoyne leaves a rather sulphurous odor about the place; the carved and inscribed lintel over his park gate is still preserved, and it is well not to let his relics be destroyed, for as a monumental and memorable miser he is invaluable. Major Skene had a wife who received an annuity from England “so long as her body should be above ground.” For eight years after her death the incarnation of avarice kept her remains in his cellar. Every year he made affidavit, with his servants for witnesses, that the conditions of the payment were still valid, and drew the pittance. People still living have seen a poor relation of the major's, Mary Skene Macferan, who lived to a great age, and remembered that, for seven successive years of her youth, she had made the sordid oath.

The memory of Skene went partly out in a fume when the revolution came, and his confiscated lands were rebaptized from the names of Colonel White and Major Hall; as Whitehall, the strange old place offered the tourists its hospitality. A pretty little cutter was placed at their disposal, and thus they went floating over the lake, touched on the shore of Vermont and drank its crystal spring-water, and, coming back, leaped out upon Putnam's Rock, where the farmer-soldier, when a young major in the British service, surprised the advancing French by night, and picked off two hun-



A TILE BAKER.

dred and fifty men from his ambush with his thirty rifles.

Sensible, however, that lakes were commonplaces, and that only canals were their affair, they longed to be reinstated in the *John C. Earle*, the only vessel that had ever seemed like home to any of them. And so the glad time came to board her again, and they took up their ravelled stitches, knitting together the same series of lovely rural towns, and greeting once more the friends who had hailed their upward passage. The Kill once again became the Canal, the Canal became the Hudson, and what was strange, it was all the same water. Finally, in the aquatic lumber district called Albany Side-Cut, they were tied again to the majestic tow, and floated into the mighty current with all the majesty of experience and ancient habit.

The passage down the Hudson was pure delight. It was a charming Sunday. The landscape, the mountains, the river, the barges, were all washed and dressed, and behaved themselves as for Sunday-school. Of the boats in the tow, more than one was an old friend, and the captains came aboard with hearty cheer, often walking the tow-lines between the boats, like rope-dancers, which is an accomplishment they have. These old neighbors naturally brought their friends to see the wonders of the sailing studio; so that the Tilers, as they lay at siesta on their tiger-skins, had again the sensation of their upward trip—the shaking tread



THE TILE BAKERY.

of innumerable quite bare, quite clean, and very heavy feet—the feet of an army of brave and friendly captains, moving in parade through their boat, and reminding them irresistibly of the silent tramp of animals into the ark.

A fine Sunday afternoon on one of these tows is a social singularity. The captains are amicable and clean-shirted, dropping their quarrels if they have any, and exchanging the navy-cut of peace and good will. Their wives and girls become daz-

awning to shreds, but didn't turn a hair for you. It was a'most as poor a time as old Van Wart had on his boat, up to Oneida Lake, when he tried to anchor with his stove, and he run a bowlin' round the stove, and the stove slipped bowlin' and they was wrecked a'most all to nothin'!"

The Tiler's assistant steersman, the French-Canadian Phileas, had found an acquaintance, an educated boatman's daughter of old Skenesboro', who in the summer did menial duty on the canal-boat *Annie Gilli-*



THE LOCK-KEEPER'S DAUGHTER.

zling with jewelry and Worth-like in toilet. A fair boatman's daughter in a Sunday "costume," guiding the tiller with one hand as she sits on a pretty camp-chair, slowly waving a gauze fan with the other, and smiling to a smart young bachelor captain on the next barge, is a pretty sight for summer sunsets to see. Snatches of characteristic conversation reached the tourists.

"Quite a smart of a thunderstorm that was as we went up," said an old comrade of our trip, to Captain Davenport. "Tore my

gan, and in winter taught French and philosophy to a school maintained on the navy of barges hibernating at Jersey City.

Supposing themselves safe from auditors, the dark-eyed steersman and the phenomenal boatman's daughter conversed with the most desperate flirting intention.

Meanwhile, the Tiler's landlady, in her best clothes, was preparing to receive some matrons of her acquaintance, in the microscopic quarters that represented her experience of home.

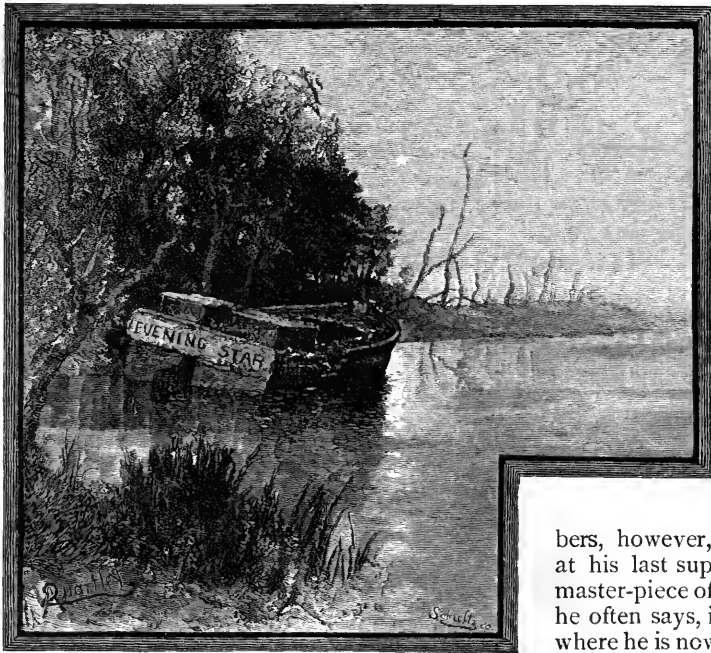

CONSIDERATIONS OF SADNESS.

"Just wait, Mrs. Montgomery," she called up the step-ladder anxiously, "till I throw my old shaker into the ketch-all, and I'll be ready for you to come down. What news have ye now?"

"Why, we had a black snake in our holt, up to Whitehall, only last month, as ever it was! And it come into my own cabin. It put its head into the molasses, and it seemed to like that, and it eat up a lot of little cakes as was there, yes, and they shot it through the window; why, they had it on the lock day in and day out, for a show; and if you've been to Whitehall they could have showed you the very lock where it was laid out."

"Laws, laws! and to think as it might have been in me as well as in you, and got into the gentlemen's provisions! But I'll ask 'em to let us go through the boat directly."

Presently, during this inspection, the visitor looks up at the sky through the hold.

"Lawks, Mary Ann Davenport, I do believe it's going to rain, and I've left my windows all open! I might just as well have left this dress of Maria's, for I haven't had time to put a stitch into it. Good-bye! You can come over and pay me a visit by moonlight."

The party lost its integrity when a little

row-boat, darting out from a turreted villa on the Hudson, bore off one of the members to his home, where his mother, a watcher in a tower-window, beheld the maneuver and compared herself to indefinite Rhine heroines of the Nibelungenlied. After this the descent to the city was commonplace. The era of uneasiness, of bag-strapping, of little casual good-byes, was come.

Daniel yet remembers, however, the appetite displayed at his last supper, which he made the master-piece of his existence. "Laws!" he often says, in the sumptuous studio where he is now major-domo and brush-washer, "how the gemmen did pitch into that 'ere chicken brile that night!

'Peared like they wa'n't never going to get enough, nor of de waffles, neither." The portly and Zouave-like waiter, who condescendingly visits him there occasionally, becomes reminiscent, and hopes that the gentlemen's appetites continue good, but remarks that one waiter to attend to that



PHILEAS'S SWEETHEART.

number of famished artists at table is a mere derision. At Saratoga, his next summer home, the contingent of service will be differently calculated.

As for Deuteronomy, so wise in his generation,—the only tourist who contrived to make the trip a period of unbroken rest,—

his whereabouts are not accurately known. But it is the confident trust of every member of the Club that some one of our excellent American reformatory institutions has taken him in hand, to confer the moral benefits that they so well know how to extend.

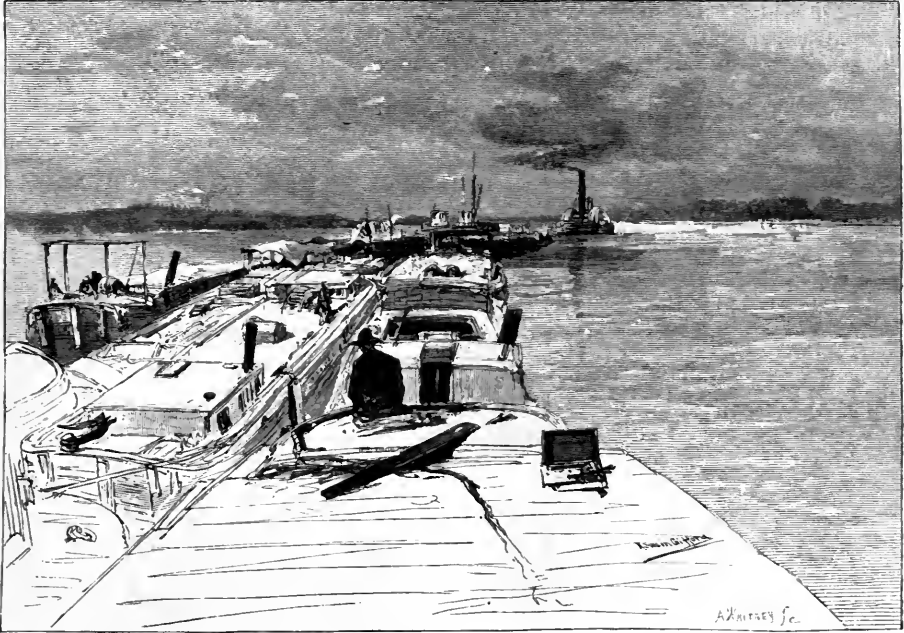

COMING HOME.

VITA NUOVA.

THOUGH I recall no word, no glance, no tone,
 Whereon my eager memory might repose,
 Yet, like the earth where grew the Persian rose,
 I feel a higher life inspire my own;—
 And since that higher life I have been near,
 Some aura, some mysterious effluence,
 Transcending all the scope of thought or sense,
 Surrounds me like a rarer atmosphere;
 And dwelling now in this new element,
 The world of daily life exalted seems;
 I walk therein as in the realm of dreams,
 Following the thought that leads me on intent,
 As if a stream that wandered aimlessly
 Had heard at last the murmur of the sea.

LOUISIANA.*

BY FRANCES HODGSON BURNETT,

Author of "That Lass o' Lowrie's," "Surlly Tim, and Other Stories," "Haworth's," etc.



"ASK YOUR SISTER," SHE REPLIED. "IT WAS HER PLAN."

CHAPTER VI.

THE ROAD TO THE RIGHT.

THE morning after, Ferrol heard an announcement which came upon him like a clap of thunder.

After breakfast, as they walked about the grounds, Olivia, who had seemed to be in an abstracted mood, said, without any preface:

"Miss Rogers returns home to-morrow."

Laurence stopped short in the middle of the path.

"To-morrow!" he exclaimed. "Oh, no."

He glanced across at Louisiana with an anxious face.

"Yes," she said, "I am going home."

"To New York?"

"I do not live in New York."

She spoke quite simply, but the words

were a shock to him. They embarrassed him. There was no coldness in her manner, no displeasure in her tone, but, of course, he understood that it would be worse than tactless to inquire further. Was it possible that she did not care that he should know where she lived? There seemed no other construction to be placed upon her words. He flushed a little, and for a few minutes looked rather gloomy, though he quickly recovered himself afterward and changed the subject with creditable readiness.

"Did not you tell me she lived in New York?" he asked Olivia, the first time they were alone together.

"No," Olivia answered, a trifle sharply. "Why New York, more than another place?"

"For no reason whatever,—really," he returned, more bewildered than ever.

"There *was* no reason why I should choose New York, only when I spoke to her of certain places there, she—she ——"

He paused and thought the matter over carefully before finishing his sentence. He ended it at last in a singular manner.

"She said nothing," he said. "It is actually true—now I think of it—she said nothing whatever!"

"And because she said nothing whatever ——" began Olivia.

He drew his hand across his forehead with a puzzled gesture.

"I fancied she *looked* as if she knew," he said, slowly. "I am sure she looked as if she knew what I was talking about—as if she knew the places, I mean. It is very queer! There seems no reason in it. Why shouldn't she wish us to know where she lives?"

"I—I must confess," cried Olivia, "that I am getting a little tired of her."

It was treacherous and vicious, and she knew it was; but her guilty conscience and her increasing sense of having bungled drove her to desperation. If she had not promised to keep the truth to herself, she would have been only too glad to unburden herself. It was so stupid, after all, and she had only herself to blame.

Laurence drew a long breath.

"You cannot be tired of *her*!" he said. "That is impossible. She takes firmer hold upon one every hour."

This was certainly true, as far as he was concerned. He was often even surprised at his own enthusiasm. He had seen so many pretty women that it was almost inconsistent that he should be so much moved by the prettiness of one charming creature, and particularly one who spoke so little, who, after all, was—but there he always found himself at a full stop. He could not say what she was, he did not know yet; really, he seemed no nearer the solution of the mystery than he had been at first. There lay the fascination. He felt so sure there was an immense deal for him to discover, if he could only discover it. He had an ideal in his mind, and this ideal, he felt confident, was the real creature, if he could only see her. During the episode on the upper gallery he fancied he had caught a glimpse of what was to be revealed. The sudden passion on her pale young face, the fire in her eyes, were what he had dreamed of.

If he had not been possessed of courage and an honest faith in himself, born of a goodly amount of success, he would have

been far more depressed than he was. She was going away, and had not encouraged him to look forward to their meeting again.

"I own it is rather bad to look at," he said to himself, "if one quite believed that Fate would serve one such an ill turn. She never played me such a trick, however, and I won't believe she will. I shall see her again—sometime. It will turn out fairly enough, surely."

So with this consolation he supported himself. There was one day left and he meant to make the best of it. It was to be spent in driving to a certain mountain, about ten miles distant. All tourists who were possessed of sufficient energy made this excursion as a matter of duty, if from no more enthusiastic motive. A strong, light carriage and a pair of horses were kept in the hotel stables for the express purpose of conveying guests to this special point.

This vehicle Ferrol had engaged the day before, and as matters had developed he had cause to congratulate himself upon the fact. He said to Louisiana what he had before said to himself:

"We have one day left, and we will make the best of it."

Olivia, who stood upon the gallery before which the carriage had been drawn up, glanced at Louisiana furtively. On her part she felt privately that it would be rather hard to make the best of it. She wished that it was well over. But Louisiana did not return her glance. She was looking at Ferrol and the horses. She had done something new this morning. She had laid aside her borrowed splendor and attired herself in one of her own dresses, which she had had the boldness to remodel. She had seized a hint from some one of Olivia's possessions, and had given her costume a pretty air of primitive simplicity. It was a plain white lawn, with a little frilled cape or fichu which crossed upon her breast, and was knotted loosely behind. She had a black velvet ribbon around her lithe waist, a rose in her bosom where the fichu crossed, and a broad Gainsborough hat upon her head. One was reminded somewhat of the picturesque young woman of the good old colony times. Ferrol, at least, when he first caught sight of her, was reminded of pictures he had seen of them.

There was no trace of her last night's fire in her manner. She was quieter than usual through the first part of the drive. She was gentle to submissiveness to Olivia.

There was something even tender in her voice once or twice when she addressed her. Laurence noticed it, and accounted for it naturally enough.

"She is really fonder of her than she has seemed," he thought, "and she is sorry that their parting with each other is so near."

He was just arriving at this conclusion when Louisiana touched his arm.

"Don't take that road," she said.

He drew up his horses and looked at her with surprise. There were two roads before them, and he had been upon the point of taking the one to the right.

"But it is the only road to take," he contended. "The other does not lead to the mountain. I was told to be sure to take the road to the right hand."

"It is a mistake," she said, in a disturbed tone. "The left-hand road leads to the mountain, too—at least, we can reach there by striking the wagon-road through the woods. I—yes, I am sure of it."

"But this is the better road. Is there any reason why you prefer the other? Could you pilot us? If you can ——"

He stopped and looked at her appealingly.

He was ready to do anything she wished, but the necessity for his yielding had passed. Her face assumed a set look.

"I can't," she answered. "Take the road to the right. Why not?"

CHAPTER VII.

"SHE AINT YERE."

FERROL was obliged to admit when they turned their faces homeward that the day was hardly a success, after all. Olivia had not been at her best, for some reason or other, and from the moment at which they had taken the right-hand road Louisiana had been wholly incomprehensible.

In her quietest mood she had never worn a cold air before; to-day she had been cold and unresponsive. It had struck him that she was absorbed in thinking of something which was quite beyond him. She was plainly not thinking of him, nor of Olivia, nor of the journey they were making. During the drive she had sat with her hands folded upon her lap, her eyes fixed straight before her. She had paid no attention to the scenery, only rousing herself to call their attention to one object. This object was a house they passed—the rambling, low-

roofed, white house of some well-to-do farmer. It was set upon a small hill and had a long front porch, mottled with blue and white paint in a sanguine attempt at imitating variegated marble.

She burst into a low laugh when she saw it.

"Look at that," she said. "That is one of the finest houses in the country. The man who owns it is counted a rich man among his neighbors."

Ferrol put up his eye-glasses to examine it. (It is to be deplored that he was a trifle near-sighted.)

"By George!" he said. "That is an idea, isn't it, that marble business! I wonder who did it? Do you know the man who lives there?"

"I have heard of him," she answered, "from several people. He is a namesake of mine. His name is Rogers."

When they returned to their carriage, after a ramble up the mountain-side, they became conscious that the sky had suddenly darkened. Ferrol looked up, and his face assumed a rather serious expression.

"If either of you is weather-wise," he said, "I wish you would tell me what that cloud means. You have been among the mountains longer than I have."

Louisiana glanced upward quickly.

"It means a storm," she said, "and a heavy one. We shall be drenched in half an hour."

Ferrol looked at her white dress and the little frilled fichu, which was her sole protection.

"Oh, but that wont do!" he exclaimed. "What insanity in me not to think of umbrellas!"

"Umbrellas!" echoed Louisiana. "If we had each six umbrellas they could not save us. We may as well get into the carriage. We are only losing time."

They were just getting in when an idea struck Ferrol which caused him to utter an exclamation of ecstatic relief.

"Why," he cried, "there is that house we passed! Get in quickly. We can reach there in twenty minutes."

Louisiana had her foot upon the step. She stopped short and turned to face him. She changed from red to white and from white to red again, as if with actual terror.

"There!" she exclaimed. "There!"

"Yes," he answered. "We can reach there in time to save ourselves. Is there any objection to our going,—in the last extremity?"

For a second they looked into each other's eyes, and then she turned and sprang into the carriage. She laughed aloud.

"Oh, no," she said. "Go there! It will be a nice place to stay—and the people will amuse you. Go there."

They reached the house in a quarter of an hour instead of twenty minutes. They had driven fast and kept ahead of the storm, but when they drew up before the picket fence the clouds were black and the thunder was rolling behind them.

It was Louisiana who got out first. She led the way up the path to the house and mounted the steps of the variegated porch. She did not knock at the door, which stood open, but, somewhat to Ferrol's amazement, walked at once into the front room, which was plainly the room of state. Not to put too fine a point upon it, it was a hideous room. The ceiling was so low that Ferrol felt as if he must knock his head against it; it was papered—ceiling and all—with paper of an unwholesome yellow enlivened with large blue flowers; there was a bedstead in one corner, and the walls were ornamented with colored lithographs of moon-faced houris, with round eyes and round, red cheeks, and wearing low-necked dresses, and flowers in their bosoms, and bright yellow gold necklaces. These works of art were the first things which caught Ferrol's eye, and he went slowly up to the most remarkable, and stood before it, regarding it with mingled wonderment and awe.

He turned from it after a few seconds to look at Louisiana, who stood near him, and he beheld what seemed to him a phenomenon. He had never seen her blush before as other women blush—now she was blushing, burning red from chin to brow.

"There—there is no one in this part of the house," she said. "I—I know more of these people than you do. I will go and try to find some one."

She was gone before he could interpose. Not that he would have interposed, perhaps. Somehow—without knowing why—he felt as if she did know more of the situation than he did—almost as if she were, in a manner, doing the honors for the time being.

She crossed the passage with a quick, uneven step, and made her way, as if well used to the place, into the kitchen at the back of the house.

A stout negro woman stood at a table, filling a pan with newly made biscuits. Her

back was toward the door and she did not see who entered.

"Aunt Cassandry," the girl began, when the woman turned toward her.

"Who's dar?" she exclaimed. "Lor', honey, how ye skeert me! I aint no C'sandry."

The face she turned was a strange one, and it showed no sign of recognition of her visitor.

It was an odd thing that the sight of her unfamiliar face should have been a shock to Louisiana; but it was a shock. She put her hand to her side.

"Wherè is my—where is Mr. Rogers?" she asked. "I want to see him."

"Out on de back po'ch, honey, right now. Dar he goes!"

The girl heard him, and flew out to meet him. Her heart was throbbing hard, and she was drawing quick, short breaths.

"Father!" she cried. "Father! Don't go in the house!"

And she caught him by both shoulders and drew him round. He did not know her at first in her fanciful-simple dress and her Gainsborough hat. He was not used to that style of thing, believing that it belonged rather to the world of pictures. He stared at her. Then he broke out with an exclamation.

"Lor—rd! Louisianny!"

She kept her eyes on his face. They were feverishly bright, and her cheeks were hot. She laughed hysterically.

"Don't speak loud," she said. "There are some strange people in the house, and—and I want to tell you something."

He was a slow man, and it took him some time to grasp the fact that she was really before him in the flesh. He said, again:

"Lord, Louisianny!" adding, cheerfully, "How ye've serprised me!"

Then he took in afresh the change in her dress. There was a pile of stove-wood stacked on the porch to be ready for use, and he sat down on it to look at her.

"Why, ye've got a new dress on!" he said. "Thet thar's what made ye look sorter curis. I hardly knowed ye."

Then he remembered what she had said on first seeing him.

"Why don't ye want me to go in the house?" he asked. "What sort o' folks air they?"

"They came with me from the Springs," she answered; "and—and I want to— to play a joke on them."

She put her hands up to her burning cheeks, and stood so.

"A joke on 'em?" he repeated.

"Yes," she said, speaking very fast. "They don't know I live here, they think I came from some city,—they took the notion themselves,—and I want to let them think so until we go away from the house. It will be such a good joke."

She tried to laugh, but broke off in the middle of a harsh sound. Her father, with one copperas-colored leg crossed over the other, was chewing his tobacco slowly, after the manner of a ruminating animal, while he watched her.

"Don't you see?" she asked.

"Wa-al, no," he answered. "Not rightly."

She actually assumed a kind of spectral gayety.

"I never thought of it until I saw it was not Cassandry who was in the kitchen," she said. "The woman who is there didn't know me, and it came into my mind that—that we might play off on them," using the phraseology to which he was the most accustomed.

"Waal, we mought," he admitted, with a speculative deliberateness. "Thet's so. We mought—if thar was any use in it."

"It's only for a joke," she persisted, hurriedly.

"Thet's so," he repeated. "Thet's so."

He got up slowly and rather lumberingly from his seat and dusted the chips from his copperas-colored legs.

"Hev ye ben enjyin' yerself, Louisianny?" he asked.

"Yes," she answered. "Never better."

"Ye must hev," he returned, "or ye wouldn't be in sperrits to play jokes."

Then he changed his tone so suddenly that she was startled.

"What do ye want me to do?" he asked.

She put her hand on his shoulder and tried to laugh again.

"To pretend you don't know me—to pretend I have never been here before. That's joke enough, isn't it? They will think so when I tell them the truth. You slow old father! Why don't you laugh?"

"Pr'aps," he said, "it's on account o' me bein' slow, Louisianny. Mebbe I shall begin arter a while."

"Don't begin at the wrong time," she said, still keeping up her feverish laugh, "or you'll spoil it all. Now come along in and—and pretend you don't know me,"

she continued, drawing him forward by the arm. "They might suspect something if we stay so long. All you've got to do is to pretend you don't know me."

"Thet's so, Louisianny," with a kindly glance downward at her excited face as he followed her out. "Thar aint no call fur me to do nothin' else, is there—jest pretend I don't know ye?"

It was wonderful how well he did it, too. When she preceded him into the room the girl was quivering with excitement. He might break down, and it would be all over in a second. But she looked Ferrol boldly in the face when she made her first speech.

"This is the gentleman of the house," she said. "I found him on the back porch. He had just come in. He has been kind enough to say we may stay until the storm is over."

"Oh, yes," said he hospitably, "stay an' welcome. Ye aint the first as has stopped over. Storms comes up sorter sudden, an' we haint the kind as turns folks away."

Ferrol thanked him, Olivia joining in with a murmur of gratitude. They were very much indebted to him for his hospitality; they considered themselves very fortunate.

Their host received their protestations with much equanimity.

"If ye'd like to set out on the front porch and watch the storm come up," he said, "thar's seats thar. Or would ye druther set here? Women-folks is gen'rally fond o' settin' in-doors whar thar's a parlor."

But they preferred the porch, and followed him out upon it.

Having seen them seated, he took a chair himself. It was a split-seated chair, painted green, and he tilted it back against a pillar of the porch and applied himself to the full enjoyment of a position more remarkable for ease than elegance. Ferrol regarded him with stealthy rapture, and drank in every word he uttered.

"This," he had exclaimed delightedly to Olivia, in private—"why, this is delightful! These are the people we have read of. I scarcely believed in them before. I would not have missed it for the world!"

"In gin'ral, now," their entertainer proceeded, "wimmin-folk is fonder o' settin' in parlors. My wife was powerful sot on her parlor. She wasn't never satisfied till she hed one an' hed it fixed up to her notion. She was allers tradin' fur picters fur it. She tuk a heap o' pride in her picters. She allers hed it in her mind that her little gal

should hev a showy parlor when she growed up."

"You have a daughter?" said Ferrol.

Their host hitched his chair a little to one side. He bent forward to expectorate, and then answered with his eyes fixed upon some distant point toward the mountains.

"Wa-al, yes," he said; "but she aint yere, Louisianny aint."

Miss Ferrol gave a little start, and immediately made an effort to appear entirely at ease.

"Did you say," asked Ferrol, "that your daughter's name was ——"

"Louisianny," promptly. "I come from thar."

Louisiana got up and walked to the opposite end of the porch.

"The storm will be upon us in a few minutes," she said. "It is beginning to rain now. Come and look at this cloud driving over the mountain-top."

Ferrol rose and went to her. He stood for a moment looking at the cloud, but plainly not thinking of it.

"His daughter's name is Lousiana," he said, in an undertone. "Louisiana! Isn't that delicious?"

Suddenly, even as he spoke, a new idea occurred to him.

"Why" he exclaimed, "your name is Louise, isn't it? I think Olivia said so."

"Yes," she answered, "my name is Louise."

"How should you have liked it," he inquired, absent-mindedly, "if it had been Louisiana?"

She answered him with a hard coolness which it startled him afterward to remember.

"How would you have liked it?" she said.

They were driven back just then by the rain, which began to beat in upon their end of the porch. They were obliged to return to Olivia and Mr. Rogers, who were engaged in an animated conversation.

The fact was that, in her momentary excitement, Olivia had plunged into conversation as a refuge. She had suddenly poured forth a stream of remark and query which had the effect of spurring up her companion to a like exhibition of frankness. He had been asking questions, too.

"She's ben tellin' mc," he said, as Ferrol approached, "thet you're a littery man, an' write fur the papers—novel-stories, an' pomes an' things. I never seen one before—not as I know on."

"I wonder why not!" remarked Ferrol.

"We are plentiful enough."

"Air ye now?" he asked reflectively. "I had an idee thar was only one on ye now an' ag'in—jest now an' ag'in."

He paused there to shake his head.

"I've often wondered how ye could do it," he said. "I couldn't. Thar's some as thinks they could if they tried, but I wa'n't never thataway—I wa'n't never thataway. I haint no idee I could do it, not if I tried ever so. Seems to me," he went on, with the air of making an announcement of so novel a nature that he must present it modestly, "seems to me, now, as if them as does it must hev a kinder gift fur it, now. Lord! I couldn't write a novel. I wouldn't know whar to begin."

"It is difficult to decide where," said Ferrol.

He did not smile at all. His manner was perfect—so full of interest, indeed, that Mr. Rogers quite warmed and expanded under it.

"The scenes on 'em all, now, bein' mostly laid in Bagdad, would be agin me, if nothin' else war," he proceeded.

"Being laid—?" queried Ferrol.

"In Bagdad or—wa-al, furrin parts tharabouts. Ye see, I couldn't tell nothin' much about no place but North Ca'liny, an' folks wouldn't buy it."

"But why not?" exclaimed Ferrol.

"Why, Lord bless ye!" he said, hilariously, "they'd know it wa'n't true. They'd say in a minnit: 'Why, thar's thet fool Rogers ben a writin' a pack o' lies thet aint a word on it true. Thar aint no castles in Hamilton County, an' thar aint no folks like these yere. It just aint so!' I 'lowed thet thar was the reason the novel-writers allers writ about things a-happenin' in Bagdad. Ye kin say most anythin' ye like about Bagdad an' no one cayn't contradict ye."

"I don't seem to remember many novels of—of that particular description," remarked Ferrol, in a rather low voice. "Perhaps my memory ——"

"Ye don't?" he queried, in much surprise. "Waal now, jest you notice an' see if it aint so. I haint read many novels myself. I haint read but one ——"

"Oh!" interposed Ferrol. "And it was a story of life in Bagdad."

"Yes; an' I've heerd tell of others as was the same. Hance Claiborn, now, he was a-tellen me of one."

He checked himself to speak to the negro woman who had presented herself at a room door.

"We're a-comin', Nancy," he said, with

an air of good-fellowship. "Now, ladies an' gentlemen," he added, rising from his chair, "walk in an' have some supper."

Ferrol and Olivia rose with some hesitation.

"You are very kind," they said. "We did not intend to give you trouble."

"Trouble!" he replied, as if scarcely comprehending. "This yere aint no trouble. Ye haint ben in North Ca'liny before, hev ye?" he continued, good-naturedly. "We're bound to hev ye eat, if ye stay with us long enough. We wouldn't let ye go 'way without eatin', bless ye. We aint that kind. Walk straight in."

He led them into a long, low room, half kitchen, half dining-room. It was not so ugly as the room of state, because it was entirely unadorned. Its ceiled walls were painted brown and stained with many a winter's smoke. The pine table was spread with a clean, homespun cloth and heaped with well-cooked, appetizing food.

"If ye can put up with country fare, ye'll not find it so bad," said the host. "Nancy prides herself on her way o' doin' things."

There never was more kindly hospitality, Ferrol thought. The simple generosity which made them favored guests at once warmed and touched him. He glanced across at Louisiana to see if she was not as much pleased as he was himself. But the food upon her plate remained almost untouched. There was a strange look on her face; she was deadly pale and her downcast eyes shone under their lashes. She did not look at their host at all; it struck Ferrol that she avoided looking at him with a strong effort. Her pallor made him anxious.

"You are not well," he said to her. "You do not look well at all."

Their host started and turned toward her.

"Why, no ye aint!" he exclaimed, quite tremulously. "Lord, no! Ye cayn't be. Ye haint no color. What—what's the trouble, Lou—Lord! I was gwine to call ye Louisianny an'—she aint yere, Louisianny aint."

He ended with a nervous laugh.

"I'm used to takin' a heap o' care on her," he said. "I've lost eleven on 'em, an' she's all that left me, an'—an' I think a heap on her. I—I wish she was yere. Ye mustn't git sick, ma'am."

The girl got up hurriedly.

"I am not sick, really," she said. "The thunder—I have a little headache. I will

go out on to the porch. It's clearing up now. The fresh air will do me good."

The old man rose, too, with a rather flurried manner.

"If Louisianny was yere," he faltered, "she could give ye something to help ye. Camphire now—sperrits of camphire—let me git ye some."

"No—no," said the girl. "No, thank you."

And she slipped out of the door and was gone.

Mr. Rogers sat down again with a sigh.

"I wish she'd let me git her some," he said, wistfully. "I know how it is with young critters like that. They're dele-cate," anxiously. "Lord, they're dele-cate. They'd oughter hev' their mothers round 'em. I know how it is with Louisianny."

A cloud seemed to settle upon him. He rubbed his grizzled chin with his hand again and again, glancing at the open door as he did it. It was evident that his heart was outside with the girl who was like "Louisianny."

CHAPTER VIII.

"NOTHING HAS HURT YOU."

THE storm was quite over, and the sun was setting in flames of gold when the meal was ended and they went out on the porch again. Mr. Rogers had scarcely recovered himself, but he had made an effort to do so, and had so far succeeded as to begin to describe the nature of the one novel he had read. Still, he had rubbed his chin and kept his eye uneasily on the door all the time he had been talking.

"It was about a Frenchman," he said, seriously, "an' his name was—Frankoyse—F-r-a-n-c-o-i-s; Frankoyse. That thar's a French name, aint it? Me an' Ianthy'lowed it was common to the country. It don't belong yere, Frankoyse don't, an' it's got a furrin sound."

"It—yes, it is a French name," assented Ferrol.

A few minutes afterward they went out. Louisiana stood at the end of the porch, leaning against a wooden pillar and twisting an arm around it.

"Are ye better?" Mr. Rogers asked. "I am goin' to 'tend to my stock, an' if ye aint, mebber the camphire—sperrits of camphire —"

"I don't need it," she answered. "I am quite well."

So he went away and left them, promising to return shortly and "gear up their critters" for them that they might go on their way.

When he was gone, there was a silence of a few seconds which Ferrol could not exactly account for. Almost for the first time in his manhood, he did not know what to say. Gradually there had settled upon him the conviction that something had gone very wrong indeed, that there was something mysterious and complicated at work, that somehow he himself was involved, and that his position was at once a most singular and delicate one. It was several moments before he could decide that his best plan seemed to be to try to conceal his bewilderment and appear at ease. And, very naturally, the speech he chose to begin with was the most unlucky he could have hit upon.

"He is charming," he said. "What a lovable old fellow! What a delicious old fellow! He has been telling me about the novel. It is the story of a Frenchman, and his name—try to guess his name."

But Louisiana did not try.

"You couldn't guess it," he went on. "It is better than all the rest. His name was—Frankoyse."

That instant she turned round. She was shaking all over like a leaf.

"Good heavens!" flashed through his mind. "This is a climax! *This* is the real creature!"

"Don't laugh again!" she cried. "Don't dare to laugh! I won't bear it! He is my father!"

For a second or so he had not the breath to speak.

"Your father!" he said, when he found his voice. "*Your father! Yours!*"

"Yes," she answered, "mine. This is my home. I have lived here all my life—my name is Louisiana. You have laughed at me too!"

It was the real creature, indeed, whom he saw. She burst into passionate tears.

"Do you think that I kept up this pretense to-day because I was ashamed of him?" she said. "Do you think I did it because I did not love him—and respect him—and think him better than all the rest of the world? It was because I loved him so much that I did it—because I knew so well that you would say to each other that he was not like me—that he was rougher, and that it was a wonder I belonged to him. It is a wonder I belong to him! I am not worthy to kiss his shoes. I have

been ashamed—I have been bad enough for that, but not bad enough to be ashamed of him. I thought at first that it would be better to let you believe what you would—that it would soon be over, and we should never see each other again, but I did not think that I should have to sit by and see you laugh because he does not know the world as you do—because he has always lived his simple, good life in one simple, country place."

Ferrol had grown as pale as she was herself. He groaned aloud.

"Oh!" he cried, "what shall I say to you? For heaven's sake try to understand that it is not at him I have laughed, but —"

"He has never been away from home," she broke in. "He has worked too hard to have time to read, and—" She stopped and dropped her hands with a gesture of unutterable pride. "Why should I tell you that?" she said. "It sounds as if I were apologizing for him, and there is no need that I should."

"If I could understand," began Ferrol,— "if I could realize —"

"Ask your sister," she replied. "It was her plan. I—I" (with a little sob) "am only her experiment."

Olivia came forward, looking wholly subdued. Her eyes were wet, too.

"It is true," she said. "It is all my fault."

"May I ask you to explain?" said Ferrol, rather sternly. "I suppose some of this has been for my benefit."

"Don't speak in that tone," said Olivia. "It is bad enough as it is. I—I never was so wretched in my life. I never dreamed of its turning out in this way. She was so pretty and gentle and quick to take a hint, and—I wanted to try the experiment—to see if you would guess at the truth. I—I had a theory, and I was so much interested that—I forgot to—think of her very much. I did not think she would care."

Louisiana broke in.

"Yes," she said, her eyes bright with pain, "she forgot. I was very fond of her, and I knew so very little that she forgot to think of me. I was only a kind of plaything—but I was too proud to remind her. I thought it would be soon over, and I knew how ignorant I was. I was afraid to trust my feeling at first. I thought perhaps—it was vanity, and I ought to crush it down. I was very fond of her."

"Oh!" cried Olivia, piteously, "don't say 'was,' Louise!"

"Don't say 'Louise,'" was the reply.
 "Say 'Louisiana.' I am not ashamed of it now. I want Mr. Ferrol to hear it."

"I have nothing to say in self-defense," Laurence replied, hopelessly.

"There is nothing for any of us to say but good-by," said Louisiana. "We shall never see each other again. It is all over between us. You will go your way and I shall go mine. I shall stay here to-night. You must drive back to the Springs without me. I ought never to have gone there."

Laurence threw himself into a chair and sat shading his face with his hand. He stared from under it at the shining wet grass and leaves. Even yet he scarcely believed that all this was true. He felt as if he were walking in a dream. The worst of it was this desperate feeling that there was nothing for him to say. There was a long silence, but at last Louisiana left her place and came and stood before him.

"I am going to meet my father," she said. "I persuaded him that I was only playing a joke. He thought it was one of my fancies, and he helped me out because I asked him to do it. I am going to tell him that I have told you the truth. He wont know why I did it. I will make it easy for you. I shall not see you again. Good-by."

Ferrol's misery got the better of him.

"I can't bear this!" he cried, springing up. "I can't, indeed."

She drew back.

"Why not?" she said. "Nothing has hurt you."

The simple coldness of her manner was very hard upon him, indeed.

"You think I have no right to complain," he answered, "and yet see how you send me away! You speak as if you did not intend to let me see you again ——"

"No," she interposed, "you shall not see me again. Why should you? Ask your sister to tell you how ignorant I am. She knows. Why should you come here? There would always be as much to laugh at as there has been to-day. Go where you need not laugh. This is not the place for you. Good-by!"

Then he knew he need say no more. She spoke with a child's passion and with a woman's proud obstinacy. Then she turned to Olivia. He was thrilled to the heart as he watched her while she did it. Her eyes were full of tears, but she had put both her hands behind her.

"Good-by," she said.

Olivia broke down altogether.

"Is that the way you are going to say good-by?" she cried. "I did not think you were so hard. If I had meant any harm—but I didn't—and you look as if you never would forgive me."

"I may sometime," answered the girl. "I don't yet. I did not think I was so hard, either."

Her hands fell at her sides and she stood trembling a second. All at once she had broken down, too.

"I loved you," she said; "but you did not love me."

And then she turned away and walked slowly into the house.

It was almost half an hour before their host came to them with the news that their carriage was ready.

He looked rather "off color" himself and wore a wearied air, but he was very uncommunicative.

"Louisiany 'lowed she'd go to bed an' sleep off her headache, instead of goin' back to the Springs," he said. "I'll be thar in a day or two to 'tend to her bill an' the rest on it. I 'low the waters haint done her much good. She aint at herself rightly. I knowed she wasn't when she was sq notionate this evenin'. She aint notionate when she's at herself."

"We are much indebted to you for your kindness," said Ferrol, when he took the reins.

"Oh, thet aint nothin'. You're welcome. You'd hev hed a better time if Louisiany had been at herself. Good-by to ye. Ye'll hev plenty of moonlight to see ye home."

Their long ride was a silent one. When they reached the end of it and Olivia had been helped out of the carriage and stood in the moonlight upon the deserted gallery, where she had stood with Louisiana in the morning, she looked very suitably miserable.

"Laurence," she said, "I don't exactly see why you should feel so very severe about it. I am sure I am as abject as any one could wish."

He stood a moment in silence looking absently out on the moonlight-flooded lawn. Everything was still and wore an air of desolation.

"We wont talk about it," he said, at last, "but you have done me an ill-turn, Olivia."

CHAPTER IX.

"DON'T YE, LOUISIANNY?"

As HE said it, Louisiana was at home in the house-room, sitting on a low chair at her father's knee and looking into the fire. She had not gone to bed. When he returned to the house her father had found her sitting here, and she had not left her place since. A wood fire had been lighted because the mountain air was cool after the rains, and she seemed to like to sit and watch it and think.

Mr. Rogers himself was in a thoughtful mood. After leaving his departing guests he had settled down with some deliberation. He had closed the doors and brought forward his favorite wooden-backed, split-seated chair. Then he had seated himself, and drawing forth his twist of tobacco had cut off a goodly "chaw." He moved slowly and wore a serious and somewhat abstracted air. Afterward he tilted backward a little, crossed his legs, and proceeded to ruminat.

"Louisianny," he said, "Louisianny, I'd like to hear the rights of it."

She answered him in a low voice.

"It is not worth telling," she said. "It was a very poor joke, after all."

He gave her a quick side glance, rubbing his crossed legs slowly.

"Was it?" he remarked. "A poor one, after all? Why, that's bad."

The quiet patience of his face was a study. He went on rubbing his leg even more slowly than before.

"That's bad," he said again. "Now, what d'ye think was the trouble, Louisianny?"

"I made a mistake," she answered. "That was all."

Suddenly she turned to him and laid her folded arms on his knee and her face upon them, sobbing.

"I oughtn't to have gone," she cried. "I ought to have stayed at home with you, father."

His face flushed, and he was obliged to relieve his feelings by expectorating into the fire.

"Louisianny," he said, "I'd like to ask ye one question. Was thar anybody thar as didn't—well, as didn't show ye respect—as was slighly or free or—or onconsiderate? Fur instants, any littery man—jest for instants, now?"

"No, no!" she answered. "They were very kind to me always."

"Don't be afeared to tell me, Louisianny," he put it to her. "I only said 'fur instants,' havin' heern as littery men was sometimes—now an' again—thataway—now an' ag'in."

"They were very good to me," she repeated, "always."

"If they was," he returned, "I'm glad of it. I'm a-gittin' old, Louisianny, an' I haint much health—dispepsy's what tells on a man," he went on deliberately. "But if thar'd a-bin any one as hed done it, I'd hev hed to settle it with him—I'd hev hed to hev settled it with him—liver or no liver."

He put his hand on her head and gave it a slow little rub, the wrong way, but tenderly.

"I aint goin' to ask ye no more questions," he said, "exceptin' one. Is thar anythin' ye'd like to hev done in the house—in the parlor, fur instants, now—s'posin' we was to say in the parlor."

"No, no," she cried. "Let it stay as it is! Let it all stay as it is!"

"Wa-al," he said, meditatively, "ye know thar aint no reason why it should, Louisianny, if ye'd like to hev it fixed up more or different. If ye'd like a new paper—say a floweryer one—or a new set of cheers an' things. Up to Lawyer Hoskin's I seen 'em with red seats to 'em, an' seemed like they did set things off sorter. If ye'd like to hev some, thar aint no reason why ye shouldn't. Things has gone purty well with me, an'—an' thar aint none left but you, honey. Lord!" he added, in a queer burst of tenderness. "Why shouldn't ye hev things if ye want 'em?"

"I don't want them," she protested. "I want nothing but you."

For a moment there was a dead silence. He kept his eyes fixed on the fire. He seemed to be turning something over in his mind. But at last he spoke:

"Don't ye, Louisianny?" he said.

"No," she answered. "Nothing."

And she drew his hand under her cheek and kissed it.

He took it very quietly.

"Ye've got a kind heart, Louisianny," he said. "Young folks gin'rally has, I think. It's sorter nat'ral, but Lord! thar's other things besides us old folks, an' it's nat'ral as ye'd want 'em. Thar's things as kin be altered, an' thar's things as cayn't. Let's alter them as kin. If ye'd like a cupolly put on the house, or, say a coat of yaller-buff paint—Sawyer's new house is yaller buff, an'

it's mighty showy; or a organ or a pianny, or more dressin', ye shall hev 'em. Them's things as it aint too late to set right, an' ye shall hev 'em."

But she only cried the more in a soft, hushed way.

"Oh, don't be so good to me," she said.

"Don't be so good and kind."

He went on as quietly as before.

"If—fur instants—it was me as was to be altered, Louisianny, I'm afeared—I'm afeared we couldn't do it. I'm afeared as I've ben let run too long—jest to put it that away. We mought hev done it if we'd hev begun airlier—say forty or fifty year back—but I'm afeared we couldn't do it now. Not as I wouldn't be willin'—I wouldn't hev a thing agin it, an' I'd try my best—but it's late. Thar's whar it is. If it was me as hed to be altered—made more modern, an' to know more, an' to hev more style—I'm afeared thar'd be a heap o' trouble. Style didn't never seem to come nat'ral to me, somehow. I'm one o' them things as cayn't be altered. Let's alter them as kin."

"I don't want you altered," she protested. "Oh! why should I, when you are such a good father—such a dear father!"

And there was a little silence again, and at the end of it he said, in a gentle, forbearing voice, just as he had said before:

"Don't ye, Louisianny?"

They sat silent again for some time afterward—indeed, but little more was said until they separated for the night. Then, when she kissed him and clung for a moment round his neck, he suddenly roused himself from his prolonged reverie.

"Lord!" he said, quite cheerfully, "it cayn't last long, at the longest, arter all—an' you're young yet, you're young."

"What can't last long?" she asked, timidly.

He looked into her eyes and smiled.

"Nothin'," he answered, "nothin' caynt. Nothin' don't—an' you're young."

And he was so far moved by his secret thought that he smoothed her hair from her forehead the wrong way again with a light touch, before he let her go.

CHAPTER X.

THE GREAT WORLD.

THE next morning he went to the Springs.

"I'll go an' settle up and bring ye your trunk an' things," he said. "Mebbe I

mayn't git back till to-morrer, so don't ye be oneasy. Ef I feel tired when I git thar, I'll stay overnight."

She did not think it likely he would stay. She had never known him to remain away from home during a night unless he had been compelled to do so by business. He had always been too childishly fond of his home to be happy away from it. He liked the routine he had been used to through forty years, the rising at daylight, the regular common duties he assumed as his share, his own seat on the hearth or porch and at table.

"Folks may be clever enough," he used to say. "They air clever, as a rule—but it don't come nat'ral to be away. Thar aint nothin' like home an' home ways."

But he did not return that night, or even the next morning. It was dusk the next evening before Louisiana heard the buggy wheels on the road.

She had been sitting on the porch and rose to greet him when he drove up and descended from his conveyance rather stiffly.

"Ye wasn't oneasy, was ye?" he asked.

"No," she answered; "only it seemed strange to know you were away."

"I haint done it but three times sence me an' Ianthy was married," he said. "Two o' them times was Conference to Barnsville, an' one was when Marcelly died."

When he mounted the porch steps he looked up at her with a smile on his weather-beaten face.

"Was ye lonesome?" he asked. "I bet ye was."

"A little," she replied. "Not very."

She gave him his chair against the wooden pillar, and watched him as he tilted back and balanced himself on its back legs. She saw something new and disturbed in his face and manner. It was as if the bit of outside life he had seen had left temporary traces upon him. She wondered very much how it had impressed him and what he was thinking about.

And after a short time he told her.

"Ye must be lonesome," he said, "arter stayin' down thar. It's nat'ral. A body don't know until they see it themselves. It's gay thar. Lord, yes! it's gay, an' what suits young folks is to be gay."

"Some of the people who were there did not think it was gay," Louisiana said, a little listlessly. "They were used to gayer places and they often called it dull, but it seemed very gay to me."

"I shouldn't want it no gayer, myself," he returned, seriously. "Not if I was young folks. Thar must hev bin three hundred on 'em in thet thar dinin'-room. The names o' the vittles writ down on paper to pick an' choose from, an' fifty or sixty waiters flyin' round. An' the dressin'! I sot an' watched 'em as they come in. I sot an' watched 'em all day. Thar was a heap o' curiosities in the way of dressin' I never seen before. I went into the dancin'-room at night, too, an' sot thar a spell an' watched 'em. They played a play. Some on 'em put little caps an' aperns on, an' rosettes an' fixin's. They sorter danced in it, an' they hed music while they was doin' it. It was purty, too, if a body could hev follered it out."

"It is a dance they call the German," said Louisiana, remembering with a pang the first night she had seen it, as she sat at her new friend's side.

"German, is it?" he said, with evident satisfaction at making the discovery. "Waal now, I aint surprised. It hed a kinder Dutch look to me—kinder Dutch an' furrin."

Just then Nancy announced that his supper was ready, and he went in, but on the threshold he stopped and spoke again:

"Them folks as was here," he said, "they'd gone. They started the next mornin' arter they was here. They live up North somewhars, an' they've went thar."

After he had gone in, Louisiana sat still for a little while. The moon was rising and she watched it until it climbed above the tree-tops and shone bright and clear. Then one desperate little sob broke from her—only one, for she choked the next in its birth, and got up and turned toward the house and the room in which the kerosene lamp burned on the supper table.

"I'll go an' talk to him," she said. "He likes to have me with him, and it will be better than sitting here."

She went in and sat near him, resting her elbows upon the table and her chin on her hands, and tried to begin to talk. But it was not very easy. She found that she had a tendency to fall back in long silent pauses, in which she simply looked at him with sad, tender eyes.

"I stopped at Casey's as I came on," he said, at last. "Thet thar was one thing as made me late. Thar's—thar's some-thin' I hed on my mind fur him to do fur me."

"For Casey to do?" she said.

He poured his coffee into his saucer and answered with a heavy effort at speaking unconcernedly.

"I'm agoin' to hev him fix the house," he said.

She was going to ask him what he meant to have done, but he did not give her time.

"Ianthy an' me," he said, "we'd usered say we'd do it sometime, an' I'm agoin' to do it now. The rooms, now, they're low—whar they're not to say small, they're low an'—an' old-timey. Thar aint no style to 'em. Them rooms to the Springs, now, they've got style to 'em. An' rooms kin be altered easy enough."

He drank his coffee slowly, set his saucer down and went on with the same serious air of having broached an ordinary subject.

"Goin' to the Springs has sorter started me off," he said. "Seein' things diff'rent does start a man off. Casey an' his men'll be here Monday."

"It seems so—sudden," Louisiana said. She gave a slow, wondering glance at the old smoke-stained room. "I can hardly fancy it looking any other way than this. It wont be the same place at all."

He glanced around, too, with a start. His coffee was hurried and nervous.

"Why, no," he said, "it wont, but—it'll be stylisher. It'll be kinder onfamil'ar at first, but I dessay we shall get used to it—an' it'll be stylisher. An' style—whar thar's young folks, thet's what's wanted—style."

She was so puzzled by his manner that she sat regarding him with wonder. But he went on talking steadily about his plans until the meal was over. He talked of them when they went back to the porch together and sat in the moonlight. He scarcely gave her an opportunity to speak. Once or twice the idea vaguely occurred to her that for some reason he did not want her to talk. It was a relief to her only to be called upon to listen, but still she was puzzled.

"When we git fixed up," he said, "ye kin hev your friends yere. Thar's them folks, now, as was yere the other day from the Springs—when we're fixed up ye mought invite 'em—next summer, fur instants. Like as not I shall be away myself an'—ye'd hev room a plenty. Ye wouldn't need me, je see. An', Lord! how it'd serprise 'em to come an' find ye all fixed."

"I should never ask them," she cried, impetuously. "And—they woulon't come if I did."

"Mebbe they would," he responded, gravely, "if ye was fixed up."

"I don't want them," she said, passionately. "Let them keep their place. I don't want them."

"Don't ye," he said, in his quiet voice. "Don't ye, Louisianny?"

And he seemed to sink into a reverie and did not speak again for quite a long time.

(To be continued.)

NOTES OF A WALKER.

VII.

THE TREE TOAD.

We can boast a greater assortment of toads and frogs in this country than can any other land. What a chorus goes up from our ponds and marshes in spring! The like of it cannot be heard anywhere else under the sun. In Europe it would certainly have made an impression upon the literature. An attentive ear will detect first one variety, then another, each occupying the stage from three or four days to a week. The latter part of April, when the little peeping frogs—*hylodes*—are in full chorus, one comes upon places in his drives or walks late in the day, where the air fairly palpitates with sound; from every little marshy hollow and spring run there rises up an impenetrable maze or cloud of shrill musical voices. The most interesting and the most shy and withdrawn of all our frogs and toads is the tree toad—the creature that, from the old apple or cherry-tree, or red cedar, announces the approach of rain, and baffles your every effort to see or discover him. It has not (as some people imagine) exactly the power of the chameleon to render itself invisible by assuming the color of the object it perches upon, but it sits very close and still, and its mottled back, of different shades of ashen gray, blends it perfectly with the bark of nearly every tree. The only change in its color I have ever noticed is that it is lighter on a light colored tree, like the beech or soft maple, and darker on the apple, or cedar, or pine. Then it is usually hidden in some cavity or hollow of the tree, when its voice appears to come from the outside.

Most of my observations upon the habits of this creature run counter to the authorities I have been able to consult on the subject.

In the first place, the tree toad is nocturnal in its habits, like the common toad. By day

it remains motionless and concealed, by night it is as alert and active as an owl, feeding and moving about from tree to tree. I have never known one to change its position by day, and never knew one to fail to do so by night. Last summer one was discovered sitting against a window upon a climbing rose-bush. The house had not been occupied for some days, and when the curtain was drawn, the toad was discovered and closely observed. His light gray color harmonized perfectly with the unpainted wood work of the house. During the day he never moved a muscle, but next morning he was gone. A friend of mine caught one, and placed it under a tumbler on his table at night, leaving the edge of the glass raised about the eighth of an inch to admit the air. During the night he was awakened by a strange sound in his room. Pat, pat, pat, went some object, now here, now there, among the furniture, or upon the walls and doors. On investigating the matter, he found that by some means his tree toad had escaped from under the glass and was leaping in a very lively manner about the room, producing the sound he had heard when it alighted upon the door, or wall, or other perpendicular surface.

The home of the tree toad, I am convinced, is usually a hollow limb or other cavity in the tree; here he makes his headquarters, and passes most of the day. For two years a pair of them frequented an old apple-tree near my house, occasionally sitting at the mouth of a cavity that led into a large branch, but usually their voices were heard from within the cavity itself. On one occasion, while walking in the woods in early May, I heard the voice of a tree toad but a few yards from me. Cautiously following up the sound, I decided, after some delay, that it proceeded from the trunk of a small soft maple; the tree was hollow, the entrance to the interior being a few feet from the ground. I could

not discover the toad, but was so convinced that it was concealed in the tree, that I stopped up the hole, determined to return with an ax, when I had time, and cut the trunk open. A week elapsed before I again went to the woods, when, on cutting into the cavity of the tree, I found a pair of tree toads, male and female, and a large shellless snail. Whether the presence of the snail was accidental, or whether these creatures associated together for some purpose, I do not know. The male toad was easily distinguished from the female by its large head, and more thin, slender, and angular body. The female was much the more beautiful both in form and color. The cavity, which was long and irregular, was evidently their home; it had been nicely cleaned out, and was a snug, safe apartment.

The finding of the two sexes together under such circumstances and at that time of the year, suggests the inquiry whether they do not breed away from the water, as others of our toads are known at times to do, and thus skip the tadpole state. I have several times seen the ground, after a June shower, swarming with minute toads, out to wet their jackets. Some of them were no larger than crickets. They were a long distance from the water, and had evidently been hatched on the land and had never been polliwigs. Whether the tree toad breeds in trees or on the land, yet remains to be determined.

Another fact in the natural history of this creature, not set down in the books, is that they pass the winter in a torpid state in the ground, or in stumps and hollow trees, instead of in the mud of ponds and marshes, like true frogs, as we have been taught. The pair in the old apple-tree above referred to, I heard on a warm, moist day late in November, and again early in April. On the latter occasion, I reached my hand down into the cavity of the tree and took out one of the toads. It was the first I had heard, and I am convinced it had passed the winter in the moist, mud-like mass of rotten wood that partially filled the cavity. It had a fresh, delicate tint, as if it had not before seen the light that spring. The president of a Western college writes in "Science News" that two of his students found one in the winter in an old stump which they demolished, and a person whose veracity I have no reason to doubt sends me a specimen that he dug out of the ground in December, while hunting for Indian relics. The place was on the top

of a hill, under a pine tree. The ground was frozen on the surface, and the toad was, of course, torpid.

During the present season, I obtained additional proof of the fact that the tree toad hibernates on dry land. The 12th of November was a warm, spring-like day; wind south-west, with slight rain in the afternoon—just the day to bring things out of their winter retreats. As I was about to enter my door at dusk, my eye fell upon what proved to be the large tree toad in question, sitting on some low stone-work at the foot of a terrace a few feet from the house. I paused to observe his movements. Presently, he started on his travels across the yard toward the lawn in front. He leaped about three feet at a time, with long pauses between each leap. For fear of losing him as it grew darker, I captured him, and kept him under the coal sieve till morning. He was very active at night trying to escape. In the morning, I amused myself with him for some time in the kitchen. I found he could adhere to a window-pane, but could not ascend it; gradually his hold yielded, till he sprang off on the casing. I observed that in sitting upon the floor or upon the ground, he avoided bringing his toes in contact with the surface, as if they were too tender or delicate for such coarse uses, but sat upon the hind part of his feet. Said toes had a very bungling, awkward appearance at such times; they looked like hands, encased in gray, woollen gloves much too large for them. Their round, flattened ends, especially when not in use, have a comically helpless look.

After a while I let my prisoner escape into the open air. The weather had grown much colder, and there was a hint of coming frost. The toad took the hint at once, and after hopping a few yards from the door to the edge of a grassy bank, began to prepare for winter. It was a curious proceeding. He went into the ground backward, elbowing himself through the turf with the sharp joints of his hind legs, and going down in a spiral manner. His progress was very slow; at night I could still see him by lifting the grass, and as the weather changed again to warm with southerly winds before morning, he stopped digging entirely. The next day I took him out, and put him into safer quarters, where I expect him to pass the winter.

The little *hylodes* or peeping frogs lead a sort of arborial life, too, a part of the season, but they are quite different from the true

tree toads, the *Hyla versicolor*, above described. They appear to leave the marshes in May, and to take to the woods or bushes. I have never seen them on trees, but upon low shrubs. They do not seem to be climbers, but perchers. I caught one in May, in some low bushes a few rods from the swamp. It perched upon the small twigs like a bird, and would leap about among them, sure of its hold every time. I was first attracted by its piping. I brought it home, and it piped for one twilight in a bush in my yard and then was gone. I do not think they pipe much after leaving the water. I have found them, early in April upon the ground in the woods, and again late in the fall.

The present November, the warm, moist weather brought them out in numbers. They were hopping about everywhere, upon the fallen leaves. Within a small space I captured six. Some of them were the hue of the tan-colored leaves, probably *Pickering's hylodes*, and some were darker, according to the locality. Of course they do not go to the marshes to winter, else they would not wait so late in the season. I examined the ponds and marshes, and found bull-frogs buried in the mud, but no peepers.

VIII.

THE SPRING BIRDS.

WE never know the precise time the birds leave us in the fall; they do not go suddenly; their departure is like that of an army of occupation in no hurry to go off; they keep going and going, and we hardly know when the last straggler is gone. Not so their return in the spring; then it is like an army of invasion, and we know the very day when the first scouts appear. It is a memorable event. Indeed, it is always a surprise to me, and one of the compensations of our abrupt and changeable climate—this suddenness with which the birds come in spring, in fact, with which Spring itself comes, alighting, may be, to tarry only a day or two, but real and genuine, for all that. When March arrives, we do not know what a day may bring forth. It is like the turning over a leaf, a new chapter of startling incidents lying just on the other side. A few days ago, winter had not perceptibly relaxed his hold; then suddenly he began to soften a little, and a warm haze to creep up from the south, but not a solitary bird, save the winter residents, was to be seen or heard. Next day the sun seemed to have

drawn immensely nearer; his beams were full of power; and we said, "Behold, the first spring morning! And, as if to make the prophesy complete, there is the note of a blue-bird, and it is not yet nine o'clock." Then others and still others were heard. How did they know it was going to be a suitable day for them to put in an appearance? It seemed as if they must have been waiting somewhere close by for the first warm day, like actors behind the scenes—the moment the curtain was lifted, they were ready and rushed upon the stage. The third warm day, and behold, all the principal performers come rushing in. Song-sparrows, cow-blackbirds, grackles, the meadow-lark, cedar-birds, the phoebe-bird, and hark! what bird laughter was that? the robins, hurrah! the robins! Not two or three, but a score or two of them; they are following the river valley north, and they stop in the trees from time to time, and give vent to their gladness. It is like a summer picnic of school children suddenly let loose in a wood; they sing, shout, whistle, squeal, call, etc., in the most blithesome strains. The warm wave has brought the birds upon its crest; or some barrier has given way, the levee of winter has broken, and spring comes like an inundation. No doubt, the snow and the frost will stop the crevasse again, but only for a brief season.

Between the 10th and the 15th of March, in the Middle and Eastern States, we are pretty sure to have one or more of these spring days. Bright days, clear days, may have been plenty all winter, but the air was a desert, the sky transparent ice; now the sky is full of radiant warmth, and the air of a half articulate murmur and awakening. How still the morning is! It is at such times that we discover what music there is in the souls of the little slate-colored snow-birds. How they squeal, and chatter, and chirp, and trill, always in scattered troops of fifty or a hundred, filling the air with a fine sibilant chorus! That joyous and child-like "chew," "chew," "chew," is very expressive. Through this medley of finer songs and calls, there is shot, from time to time, the clear, strong note of the meadow-lark. It comes from some field or tree farther away, and cleaves the air like an arrow. The reason why the birds always appear first in the morning, and not in the afternoon, is that in migrating they travel by night, and stop, and feed, and disport themselves by day. They come by the owl train, and are here before we are up in the morning.

IX.

TYPICAL FACTS.

IT is a fact in the natural history of the country that, in the South, birds run more to beak and claw, and in the West to tail, than they do in the North and East. The beak and claw, I take it, mean ferocity, mean bowie knives and the Kuklux, and the tail, I am loth to say, means brag. The West is windy, and the South is fierce and hot.

X.

FOX AND HOUND.

I STOOD on a high hill or ridge one autumn day and saw a hound run a fox through the fields far beneath me. What odors that fox must have shaken out of himself, I thought, to be traced thus easily, and how great their specific gravity not to have been blown away like smoke by the breeze! The fox ran a long distance down the hill, keeping within a few feet of a stone wall; then turned a right angle and led off for the mountain, across a plowed field and a succession of pasture lands. In about fifteen minutes the hound came in full blast with her nose in the air, and never once did she put it to the ground while in my sight. When she came to the stone wall she took the other side from that taken by the fox, and kept about the same distance from it, being thus separated several yards from his track, with the fence between her and it. At the point where the fox turned sharply to the left, the hound overshot a few yards, then wheeled, and feeling the air a moment with her nose, took up the scent again and was off on his trail as unerringly as Fate. It seemed as if the fox must have sowed himself broadcast as he went along, and that his scent was so rank and heavy that it settled in the hollows and clung tenaciously to the bushes and crevices in the fence. I thought I ought to have caught a remnant of it as I passed that way some minutes later, but I did not. But I suppose it was not that the light-footed fox so impressed himself upon the ground he ran over, but that the sense of the hound was so keen. To her sensitive nose these tracks steamed like hot cakes, and they would not have cooled off so as to be undistinguishable for several hours. For the time being she had but one sense: her whole soul was concentrated in her nose.

It is amusing when the hunter starts out of a winter morning to see his hound probe the old tracks to determine how recent they are. He sinks his nose down deep in the snow so as to exclude the air from above, then draws a long full breath, giving sometimes an audible snort. If there remains the least effluvia of the fox then the hound will detect it. If it be very slight it only sets his tail wagging; if it be strong it unloosens his tongue.

Such things remind one of the waste, the friction that is going on all about us, even when the wheels of life run the most smoothly. A fox cannot trip along the top of a stone wall so lightly but that he will leave enough of himself to betray his course to the hound for hours afterward. When the boys play "hare and hounds" the hare scatters bits of paper to give a clew to the pursuers, but he scatters himself much more freely if only our sight and scent were sharp enough to detect the fragments. Even the fish leave a trail in the water, and it is said the otter will pursue them by it. The birds make a track in the air, only their enemies hunt by sight rather than by scent. The fox baffles the hound most upon a hard crust of frozen snow; the scent will not hold to the smooth bead-like granules.

Judged by the eye alone, the fox is the lightest and most buoyant creature that runs. His soft wrapping of fur conceals the muscular play and effort that is so obvious in the hound that pursues him, and he comes bounding along precisely as if blown by a gentle wind. His massive tail is carried as if it floated upon the air by its own lightness.

The hound is not remarkable for his fleetness, but how he will hang!—often running late into the night and sometimes till morning, from ridge to ridge, from peak to peak; now on the mountain, now crossing the valley, now playing about a large slope of uplying pasture fields. At times the fox has a pretty well-defined orbit, and the hunter knows where to intercept him. Again he leads off like a comet, quite beyond the system of hills and ridges upon which he was started, and his return is entirely a matter of conjecture, but if the day be not more than half spent, the chances are that the fox will be back before night, though the sportsman's patience seldom holds out that long.

The hound is a most interesting dog. How solemn and long-visaged he is—how peaceful and well-disposed! He is the

Quaker among dogs. All the viciousness and currihness seem to have been weeded out of him; he seldom quarrels, or fights, or plays, like other dogs. Two strange hounds, meeting for the first time, behave as civilly toward each other as two men. I know a hound that has an ancient, wrinkled, human, far-away look that reminds one of the bust of Homer among the Elgin marbles. He looks like the mountains toward which his heart yearns so much.

The hound is a great puzzle to the farm dog; the latter, attracted by his baying, comes barking and snarling up through the fields bent on picking a quarrel; he intercepts the hound, snubs and insults and annoys him in every way possible, but the hound heeds him not; if the dog attacks him he gets away as best he can, and goes on with the trail; the cur bristles and barks and struts about for a while, then goes back to the house, evidently thinking the hound a lunatic, which he is for the time being—a monomaniac, the slave and victim of one idea. I saw the master of a hound one day arrest him in full course, to give one of the hunters time to get to a certain runaway; the dog cried and struggled to free himself and would listen neither to threats nor caresses. Knowing he must be hungry, I offered him my lunch, but he would not touch it. I put it in his mouth, but he threw it contemptuously from him. We coaxed and petted an! re-assured him, but he was under a spell; he was bereft of all thought or desire but the one passion to pursue that trail.

XI.

WEEDS.

THE gardener and farmer often has occasion to be surprised at the resources of Nature. It is an unequal game we play with her; her sleeve is full of cards, and many of them are trumps. It is in her plan, for instance, to keep the ground constantly covered with vegetation of some sort, and she has layer upon layer of seeds in the soil for this purpose, and the wonder is that each kind lies dormant until it is wanted. Defeat her on one, and she plays the next and the next. Turn over the sward, and up spring rag-weed and pig-weed and red-root; demolish these, and up comes "pusley," a great, fat, tender, lubberly weed; sweep the board of this trick, and down comes a bower in the shape of twitch-grass, or fox-tail, or some other pest. Press her further, and

probably she will go through the series again and play rag-weed and red-root, or smart-weed, next time. Sprinkle wood ashes upon the soil, and white clover springs up and chokes your strawberries. In the spring I covered some rocks with soil taken from a depth of two or three feet in the earth; before fall a good crop of weeds was flourishing upon them.

Prevent the wild onion from multiplying by seed at the top, and it will multiply at the root. Here, all about the fields, is the wild carrot. You cut off its head, just before it seeds, and you think you have squelched it; but this is just what Nature—or the devil—wanted you to do. In a week or so there are five heads in room of this one; cut off these, and before fall there are ten looking defiance at you from the same spot. It is like killing flies; a dozen come to the funeral of every one you kill.

Some fields, under the plow, are always infested with cockle, or with blind nettle; whenever the sward is broken they appear. Yet it is pleasant to remember that, in our climate, there is no weed so persistent and lasting and universal as grass. Grass is the natural covering of the fields. There are but one or two weeds that it will not run out in a good soil. We crop it and mow it year after year, and yet, if the season favors, it is sure to come again. Turn a sod over, and sometimes the grass will reverse itself and grow up the other way. Fields that have never known the plow and never been seeded, are yet covered with grass. Weeds are Nature's make-shift; they are quick and hardy, and shade the ground while the grass is slowly forming beneath them; they will grow, also, on soil too poor or too dry for grass. If your grass-seed takes and thrives, all right; if it does not, behold the weeds, with which Nature seeks to cover her nakedness! Most weeds have some virtues; they are not wholly malevolent. Even the hateful toad-flax, which nothing will eat and which on poor soil will run out the grass, affords honey for the bumble-bee. Narrow-leaved plantain is readily eaten by cattle, and the bee gathers much pollen from it. The ox-eyed daisy makes tolerable hay, if cut before it gets ripe. The cows will eat the leaves of the burdock and the stinging nettles in the woods. But what cannot a cow's tongue stand? She will crop the poison ivy with impunity, and I think would eat thistles, if she found them growing in the garden. Leeks and garlics are readily eaten by cattle in the spring, and are said to

be good for them. They kill the lice, but spoil the milk. Weeds that yield neither pasturage for bee nor herd, yet afford seeds for the fall and winter birds. This is true of most of the obnoxious weeds of the garden, and of thistles. Some of the most troublesome and persistent weeds have escaped from cultivation, like "live-forever," a plant that defies the plow and the hoe and the scythe,—for it is almost an air-plant,—and one that nothing but grazing cattle will exterminate. As soon as it comes to the surface to breathe, they crop it, and its root soon perishes. Weeds are like rats and mice—they multiply and spread, though every hand is against them. In this country the highway is their great refuge. Driven from the fields by the plow and the scythe, they establish themselves by the road-side, where they are seldom disturbed, and whence they keep up a sort of guerrilla warfare upon the farmer. Elecampane, milk-weed, teasles, thistles, golden-rod, and many others keep a foothold here, and make incursions upon the land. Weeds seem to travel by the highway, too. Indeed, I think they take the train from one section of the country to another, like the Colorado beetle, as an incursion of a strange weed is often first noticed along the line of the railroad. I was recently in a section of the country, well known to me, where I had never seen the wild carrot, and where the farmers said it did not exist. But one day in my rambles, I found two plants in bloom in a field that lay high up on the side of the mountain, and wondered where they could have come from. Not long after, in crossing a mountain several miles distant, I beheld a flourishing colony of the carrots by the road-side. "Here is the camp," I said, "and from here the pests will distribute themselves over the land." Already I could see little groups of them about the adjoining meadows. In ten or a dozen years, the farmers of that section will be fighting the fire that, so easy to squelch at its beginning, is so baffling when once it gets under full blast. Part of the duties of the road commissioner of every township should be to see that no noxious weeds are allowed to flourish unmolested by the highway.

There will be enough weeds left to fill up the waste places, however vigorous the warfare we wage upon them. Nature seems unduly upon their side. Where she has not given them wings to fly with, or feet to walk with, she has armed them with hooks and claws to seize upon the skirts of every pass-

ing object, and thus get themselves disseminated.

Of human weeds I shall not now speak except to observe how seedy they are, how they increase and multiply over the more valuable and highly cultivated plants.

XII.

AIR-FOOD.

It is a very suggestive fact, which you may read in any of the agricultural books, that growing plants—grain, grass, trees, etc., draw from ninety-five to ninety-eight per cent. of their material from the atmosphere, leaving a very small fraction to be taken from the earth. It is quite startling. We take great pains to give the melons, and the corn, and the cauliflower good earth, and yet they take but a crumb from the soil, and make what may be called a full meal off the air. We bend all the resources of agriculture into fattening and leavening the land; we drain, and subsoil, and harrow, and pulverize; we mix in gypsum, and guano, and phosphates, and prepare the ground as if it were so much short-cake that our wheat and oats, or our grapes and strawberries were going to eat; and then along comes the agricultural chemist, and tells us "this is all very well," but the great source of plant food is the air; all your growing crops want of you is a little salt for seasoning, a pinch of this or that for a relish. But how important this pinch is. It furnishes the stimulus that digests the whole meal; the fertile and flowing air bathes all alike; yet without the pound or so of soluble salts which every ton of soil contains, and which it is the business of agriculture to keep from falling below a certain amount, the land would be as barren as a desert. The myriad roots of the plants and trees go groping and feeling their way through the ground, in search of these tiny particles. No California gold miner, or South African diamond hunter, ever sifted and searched the soil so thoroughly. These earth elements, potash, soda, lime, iron, magnesia, etc., furnish the material basis, the osseous frame-work of the plant; upon them the whole structure of the vegetable kingdom is built.

Does not this fact in some way tell the whole story of man's relation to the physical universe, to the world of sense and experience? He, too, is a plant rooted to the material world by his senses, sight, hearing,

touch, taste, smell; through these he takes up the earth elements, the hard facts of experience, his moral and intellectual lime, and iron, and silica; these form the basis of his knowledge; they combine endlessly with the deductions and intuitions of the spirit; they enable him to seize upon, and body forth the impressions that come to him from super-sensuous sources; in fact without them he is nothing. But a man's life is in his senses no more and no less than the life of the plant is in its roots; his

head is bathed in the ideal, and thence he draws the elements that give scope and power and volume to his life. The fluid and plastic ideal, the cosmic and boundless air that the soul inhales, this is the great storehouse of man's life. His knowledge, his ideas, his treasures of art and literature, have a sensuous origin, just as this fruit has a mineral or telluric origin; two or three per cent. of it came from the soil, but its net-work of living tissues was built up from the imponderable gases that swim above.

THE GRANDISSIMES.*

A STORY OF CREOLE LIFE.

By GEORGE W. CABLE, author of "Old Creole Days."

CHAPTER XXI.

DOCTOR KEENE RECOVERS HIS BULLET.

It early attracted the apothecary's notice, in observing the civilization around him, that it kept the flimsy false bottoms in its social errors only by incessant reiteration. As he re-entered his shop, dissatisfied with himself for accepting M. Grandissime's invitation to ride, he knew by the fervent words which he overheard from the lips of his employee that the f. m. c. had been making one of his reconnoissances, and possibly had ventured in to inquire for his tenant.

"I t'ink, me, dat hanny w'ite man is a gen'laman; but I don't care if a man are good like a h-angel, if 'e har not pu'e w'ite, 'ow can 'e be a gen'laman?"

Raoul's words were addressed to a man who, as he rose up and handed Frowenfeld a note, ratified the Creole's sentiment by a spurt of tobacco juice and an affirmative "Hm-m."

The note was a lead-pencil scrawl, without date.

"DEAR JOE: Come and see me sometime this evening. I am on my back in bed. Want your help in a little matter.

Yours,
KEENE.

I have found out who — —"

Frowenfeld pondered: "I have found out who — —" Ah! Doctor Keene had found out who stabbed Agricola.

Some delays occurred in the afternoon,

but toward sunset the apothecary dressed and went out. From the doctor's bedside in the rue St. Louis, if not delayed beyond all expectation, he would proceed to visit the ladies at Number 19 rue Bienville. The air was growing cold and threatening bad weather.

He found the Doctor prostrate, wasted, hoarse, cross, and almost too weak for speech. He could only whisper, as his friend approached his pillow:

"These vile lungs!"

"Hemorrhage?"

The invalid held up three small, freckled fingers.

Joseph dared not show pity in his gaze, but it seemed savage not to express some feeling, so after standing a moment he began to say:

"I am very sorry —"

"You needn't bother yourself!" whispered the Doctor, who lay frowning upward. By and by he whispered again.

Frowenfeld bent his ear, and the little man, so merry when well, repeated, in a savage hiss:

"Sit down!"

It was some time before he again broke the silence.

"Tell you what I want—you to do—for me."

"Well, sir —"

"Hold on!" gasped the invalid, shutting his eyes with impatience,— "till I get through."

He lay a little while motionless, and then

drew from under his pillow a wallet, and from the wallet a pistol-ball:

"Took that out—a badly neglected wound—last day I saw you." Here a pause, an appalling cough, and by and by a whisper: "knew the bullet in an instant." He smiled wearily. "Peculiar size." He made a feeble motion. Frowenfeld guessed the meaning of it and handed him a pistol from a small table. The ball slipped softly home. "Refused two hundred dollars—those pistols"—with a sigh and closed eyes. By and by again—"Patient had smart fever—but it will be gone—time you get—there. Want you to—take care—t' I get up."

"But, Doctor —"

The sick man turned away his face with a petulant frown; but presently, with an effort at self-control, brought it back and whispered:

"You mean you—not physician?"

"Yes."

"No. No more are half—doc's. You can do it. Simple gun-shot wound in the shoulder." A rest. "Pretty wound; ranges"—he gave up the effort to describe it. "You'll see it." Another rest. "You see—this matter has been kept quiet so far. I don't want any one—else to know—anything about it." He sighed audibly and looked as though he had gone to sleep, but whispered again, with his eyes closed—"specially on culprit's own account."

Frowenfeld was silent; but the invalid was waiting for an answer, and, not getting it, stirred peevishly.

"Do you wish me to go to-night?" asked the apothecary.

"To-morrow morning. Will you —?"

"Certainly, Doctor."

The invalid lay quite still for several minutes, looking steadily at his friend, and finally let a faint smile play about his mouth,—a wan reminder of his habitual roguery.

"Good boy," he whispered.

Frowenfeld rose and straightened the bed-clothes, took a few steps about the room, and finally returned. The Doctor's restless eye had followed him at every movement.

"You'll go?"

"Yes," replied the apothecary, hat in hand; "where is it?"

"Corner Bienville and Bourbon,—upper river corner,—yellow one-story house, door-steps on street. You know the house?"

"I think I do."

"Good-night. Here!—I wish you would send that black gin in here—as you go out

—make me better fire—Joe!" the call was a ghostly whisper.

Frowenfeld paused in the door.

"You don't mind my—bad manners, Joe?"

The apothecary gave one of his infrequent smiles.

"No, Doctor."

He started toward No. 19 rue Bienville; but a light, cold sprinkle set in, and he turned back toward his shop. No sooner had the rain got him there than it stopped, as rain sometimes will do.

CHAPTER XXII.

WARS WITHIN THE BREAST.

THE next morning came in frigid and gray. The unseasonable numerals which the meteorologist recorded in his tables might have provoked a superstitious lover of better weather to suppose that Monsieur Danny, the head imp of discord, had been among the aerial currents. The passionate southern sky, looking down and seeing some six thousand to seventy-five hundred of her favorite children disconcerted and shivering, tried in vain, for two hours, to smile upon them with a little frozen sunshine, and finally burst into tears.

In thus giving way to despondency, it is sad to say, the sky was closely imitating the simultaneous behavior of Aurora Nancanou. Never was pretty lady in cheerier mood than that in which she had come home from Honoré's counting-room. Hard would it be to find the material with which to build again the castles-in-air that she founded upon two or three little discoveries there made. Should she tell them to Clotilde? Ah! and for what? No, Clotilde was a dear daughter—ha! few women were capable of having such a daughter as Clotilde; but there were things about which she was entirely too scrupulous. So, when she had come in from that errand, profoundly satisfied that she would in future hear no more about the rent than she might choose to hear, she had been too shrewd to expose herself to her daughter's catechising. She would save her little revelations for disclosure when they might be used to advantage. As she threw her bonnet upon the bed, she exclaimed, in a tone of gentle and wearied reproach:

"Why did you not remind me that M. Honoré Grandissime, that precious somebody-great, has the honor to rejoice in a

quadroon half-brother of the same illustrious name? Why did you not remind me, eh?"

"Ah! and you know it as well as A, B, C," playfully retorted Clotilde.

"Well, guess which one is our landlord?"

"Which one?"

"*Ma foi!* how do I know? I had to wait a shameful long time to see *Monsieur le prince*,—just because I am a De Grapion, I know. When at last I saw him, he says, 'Madame, this is the other Honoré Grandissime.' There, you see we are the victims of a conspiracy; if I go to the other, he will send me back to the first. But, Clotilde, my darling," cried the speaker, beamingly, "dismiss all fear and care; we shall have no more trouble about it."

"And how, indeed, do you know that?"

"Something tells it to me in my ear. I feel it! Trust in Providence, my child. Look at me, how happy I am; but you— you never trust in Providence. That is why we have so much trouble,—because you don't trust in Providence. Oh! I am so hungry, let us have dinner."

"What sort of a person is M. Grandissime in his appearance?" asked Clotilde, over their feeble excuse for a dinner.

"What sort? Do you imagine I had nothing better to do than notice whether a Grandissime is good-looking or not? For all I know to the contrary, he is—some more rice, please, my dear."

But this light-heartedness did not last long. It was based on an unutterable secret, all her own, about which she still had trembling doubts; this, too, notwithstanding her consultation of the dark oracles. She was going to stop that. In the long run, these charms and spells themselves bring bad luck. Moreover, the practice, indulged in to excess, was wicked, and she had promised Clotilde,—that droll little saint,—to resort to them no more. Hereafter, she should do nothing of the sort, except, to be sure, to take such ordinary precautions against misfortune as casting upon the floor a little of whatever she might be eating or drinking to propitiate M. Assonquer. She would have liked, could she have done it without fear of detection, to pour upon the front door-sill an oblation of beer sweetened with black molasses to Papa Lébat (who keeps the invisible keys of all doors that admit suitors), but she dared not; and then, the hound would surely have licked it up. Ah me! was she forgetting that she was a widow?

She was in poor plight to meet the all but

icy gray morning; and, to make her misery still greater, she found, on dressing, that an accident had overtaken her, which she knew to be a trustworthy sign of love grown cold. She had lost—alas! how can we communicate it in English!—a small piece of lute-string ribbon, about *so long*, which she used for—not a necktie exactly, but —

And she hunted and hunted, and couldn't bear to give up the search, and sat down to breakfast and ate nothing, and rose up and searched again (not that she cared for the omen), and struck the hound with the broom, and broke the broom, and hunted again, and looked out the front window, and saw the rain beginning to fall, and dropped into a chair—crying, "Oh! Clotilde, my child, my child! the rent collector will be here Saturday and turn us into the street!" and so fell a-weeping.

A little tear-letting lightened her unrevealing burden, and she rose, rejoicing that Clotilde had happened to be out of eye-and-ear-shot. The scanty fire in the fire-place was ample to warm the room; the fire within her made it too insufferably hot! Rain or no rain, she parted the window-curtains and lifted the sash. What a mark for Love's arrow she was, as, at the window, she stretched her two arms upward! And, "right so," who should chance to come cantering by, the big drops of rain pattering after him, but the knightliest man in that old town, and the fittest to perfect the fine old-fashioned poetry of the scene!

"Clotilde," said Aurora, turning from her mirror, whither she had hastened to see if her face showed signs of tears (Clotilde was entering the room), "we shall never be turned out of this house by Honoré Grandissime!"

"Why?" asked Clotilde, stopping short in the floor, forgetting Aurora's trust in Providence, and expecting to hear that M. Grandissime had been found dead in his bed.

"Because I saw him just now; he rode by on horseback. A man with that noble face could never *do such a thing!*"

The astonished Clotilde looked at her mother searchingly. This sort of speech about a Grandissime? But Aurora was the picture of innocence.

Clotilde uttered a derisive laugh.

"*Impertinente!*" exclaimed the other, laboring not to join in it.

"Ah-h-h!" cried Clotilde, in the same mood, "and what face had he when he wrote that letter?"

"What face?"

"Yes, what face?"

"I do not know what face you mean," said Aurora.

"What face," repeated Clotilde, "had Monsieur Honoré de Grandissime on the day that he wrote ——"

"Ah, f-fah!" cried Aurora, and turned away, "you don't know what you are talking about! You make me wish sometimes that I were dead!"

Clotilde had gone and shut down the sash, as it began to rain hard and blow. As she was turning away, her eye was attracted by an object at a distance.

"What is it?" asked Aurora, from a seat before the fire.

"Nothing," said Clotilde, weary of the sensational,—*"a man in the rain."*

It was the apothecary of the rue Royale, turning from that street toward the rue Bourbon, and bowing his head against the swirling norther.

CHAPTER XXIII.

FROWENFELD KEEPS HIS APPOINTMENT.

DOCTOR KEENE, his ill-humor slept off, lay in bed in a quiescent state of great mental enjoyment. At times he would smile and close his eyes, open them again and murmur to himself, and turn his head languidly and smile again. And when the rain and wind, all-tangled together, came against the window with a whirl and a slap, his smile broadened almost to laughter.

"He's in it," he murmured, "he's just about getting there. I would give fifty dollars to see him when he first gets into the house and sees where he is."

As this wish was finding expression on the lips of the little sick man, Joseph Frowenfeld was making room on a narrow doorstep for the outward opening of a pair of small batten doors, upon which he had knocked with the vigorous haste of a man in the rain. As they parted, he hurriedly helped them open, darted within, heedless of the odd black shape which shuffled out of his way, wheeled and clapped them shut again, swung down the bar and then turned, and with the good-natured face that properly goes with a ducking, looked to see where he was.

One object—around which everything else instantly became nothing—set his gaze. On the high bed, whose hangings of blue we have already described, silently regarding the intruder with a pair of eyes that

sent an icy thrill through him and fastened him where he stood, lay Palmyre Philosophe. Her dress was a long, snowy morning-gown, wound loosely about at the waist with a cord and tassel of scarlet silk; a bright-colored woolen shawl covered her from the waist down, and a necklace of red coral heightened to its utmost her untamable beauty.

An instantaneous indignation against Doctor Keene set the face of the speechless apothecary on fire, and this, being as instantaneously comprehended by the philosophe, was the best of introductions. Yet, her gaze did not change.

The Congo negress broke the spell with a bristling protest, all in African b's and k's, but hushed and drew off at a single word of command from her mistress.

In Frowenfeld's mind an angry determination was taking shape, to be neither trifled with nor contemned. And this again the quadron discerned, before he was himself aware of it.

"Doctor Keene" —— he began, but stopped, so uncomfortable were her eyes.

She did not stir or reply.

Then he bethought him with a start, and took off his dripping hat.

At this a perceptible sparkle of imperious approval shot along her glance; it gave the apothecary speech.

"The doctor is sick, and has asked me to dress your wound."

She made the slightest discernible motion of the head, remained for a moment silent, and then, still with the same eye, motioned her hand toward a chair near a comfortable fire.

He sat down. It would be well to dry himself. He drew near the hearth and let his gaze fall into the fire. When he presently lifted his eyes and looked full upon the woman with a steady, candid glance, she was regarding him with apparent coldness, but with secret diligence and scrutiny, and a yet more inward and secret surprise and admiration. Hard rubbing was bringing out the grain of the apothecary. But she presently suppressed the feeling. She hated men.

But Frowenfeld, even while his eyes met hers, could not resent her hostility. This monument of the shame of two races—this poisonous blossom of crime growing out of crime—this final, unanswerable white man's accuser—this would-be murderer—what ranks and companies would have to stand up in the Great Day with her and answer

as accessory before the fact! He looked again into the fire.

The patient spoke :

"*Eh bi'n, Miché?*" Her look was severe, but less aggressive. The shuffle of the old negress's feet was heard and she appeared bearing warm and cold water and fresh bandages ; after depositing them she tarried.

"Your fever is gone," said Frowenfeld, standing by the bed. He had laid his fingers on her wrist. She brushed them off and once more turned full upon him the cold hostility of her passionate eyes.

The apothecary, instead of blushing, turned pale.

"You—" He was going to say, "You insult me;" but his lips came tightly together. Two big cords appeared between his brows, and his blue eyes spoke for him. Then, as the returning blood rushed even to his forehead, he said, speaking his words one by one :

"Please understand that you must trust me."

She may not have understood his English, but she comprehended, nevertheless. She looked up fixedly for a moment, then passively closed her eyes. Then she turned, and Frowenfeld put out one strong arm, helped her to a sitting posture on the side of the bed and drew the shawl about her.

"Zizi," she said, and the negress, who had stood perfectly still since depositing the water and bandages, came forward and proceeded to bare the philosophe's superb shoulder. As Frowenfeld again put forward his hand, she lifted her own as if to prevent him, but he kindly and firmly put it away and addressed himself with silent diligence to his task ; and by the time he had finished, his womanly touch, his commanding gentleness, his easy dispatch, had inspired Palmyre not only with a sense of safety, comfort, and repose, but with a pleased wonder.

This woman had stood all her life, with dagger drawn, on the defensive against what certainly was to her an unmerciful world. With possibly one exception, the man now before her was the only one she had ever encountered whose speech and gesture were clearly keyed to that profound respect which is woman's first, foundation claim on man. And yet by inexorable decree, she belonged to what we used to call "the happiest people under the sun." We ought to stop saying that.

So far as Palmyre knew, the entire mas-

culine wing of the mighty and exalted race, three-fourths of whose blood bequeathed her none of its prerogatives, regarded her as legitimate prey. The man before her did not. There lay the fundamental difference that, in her sight, as soon as she discovered it, glorified him. Before this assurance the cold fierceness of her eyes gave way, and a friendlier light from them rewarded the apothecary's final touch. He called for more pillows, made a nest of them, and, as she let herself softly into it, directed his next consideration toward his hat and the door.

It was many an hour after he had backed out into the trivial remains of the rain-storm before he could replace with more tranquilizing images the vision of the philosophe reclining among her pillows, in the act of making that uneasy movement of her fingers upon the collar button of her robe, which women make when they are uncertain about the perfection of their dishabille, and giving her inaudible adieu with the majesty of an empress.

CHAPTER XXIV.

FROWENFELD MAKES AN ARGUMENT.

ON the afternoon of the same day on which Frowenfeld visited the house of the philosophe, the weather, which had been so unfavorable to his late plans, changed ; the rain ceased, the wind drew around to the south, and the barometer promised a clear sky. Wherefore he decided to leave his business, when he should have made his evening weather notes, to the care of M. Raoul Innerarity, and venture to test both Mademoiselle Clotilde's repellent attitude and Aurora's seeming cordiality at No. 19 rue Bienville.

Why he should go was a question which the apothecary felt himself but partially prepared to answer. What necessity called him, what good was to be effected, what was to happen next, were points he should have liked to be clear upon. That he should be going merely because he was invited to come—merely for the pleasure of breathing their atmosphere—that he should be supinely gravitating toward them—this conclusion he positively could not allow ; no, no ; the love of books and the fear of women alike protested.

True, they were a part of that book which is pronounced "the proper study of mankind,"—indeed, that was probably the

reason which he sought: he was going to contemplate them as a frontispiece to that unwriteable volume which he had undertaken to con. Also, there was a charitable motive. Doctor Keene, months before, had expressed a deep concern regarding their lack of protection and even of daily provision; he must quietly look into that. Would some unforeseen circumstance shut him off this evening again from this very proper use of time and opportunity?

As he was sitting at the table in his back room, registering his sunset observations, and wondering what would become of him if Aurora should be out and that other in, he was startled by a loud, deep voice exclaiming, close behind him:

"*Eh, bien! Monsieur le Professeur!*"

Frowenfeld knew by the tone, before he looked behind him, that he would find M. Agricola Fusilier very red in the face; and when he looked, the only qualification he could make was that the citizen's countenance was not so ruddy as the red handkerchief in which his arm was hanging.

"What have you there?" slowly continued the patriarch, taking his free hand off his fettered arm and laying it upon the page as Frowenfeld hurriedly rose, and endeavored to shut the book.

"Some private memoranda," answered the meteorologist, managing to get one page turned backward, reddening with confusion and indignation, and noticing that Agricola's spectacles were upside down.

"Private! Eh? No such thing, sir! Professor Frowenfeld, allow me" (a classic oath) "to say to your face, sir, that you are the most brilliant and the most valuable man—of your years—in afflicted Louisiana! Ha!" (reading): "'Morning observation; Cathedral clock, 7 A. M. Thermometer 70 degrees.' Ha! 'Hygrometer 15'—but this is not to-day's weather? Ah! no. Ha! 'Barometer 30.380.' Ha! 'Sky, cloudy, dark; wind, south, light.' Ha! 'River rising.' Ha! Professor Frowenfeld, when will you give your splendid services to your section? You must tell me, my son, for I ask you, my son, not from curiosity, but out of impatient interest."

"I cannot say that I shall ever publish my tables," replied the "son," pulling at the book.

"Then, sir, in the name of Louisiana," thundered the old man, clinging to the book, "I can! They shall be published! Ah! yes, dear Frowenfeld. The book, of course,

will be in French, eh? You would not so affront the most sacred prejudices of the noble people to whom you owe everything as to publish it in English? You—ah! have we torn it?"

"I do not write French," said the apothecary, laying the torn edges together.

"Professor Frowenfeld, men are born for each other. What do I behold before me? I behold before me, in the person of my gifted young friend, a supplement to myself! Why has Nature strengthened the soul of Agricola to hold the crumbling fortress of this body until these eyes—which were once, my dear boy, as proud and piercing as the battle steed's—have become dim?"

Joseph's insurmountable respect for gray hairs kept him standing, but he did not respond with any conjecture as to Nature's intentions, and there was a stern silence.

The crumbling fortress resumed, his voice pitched low like the beginning of the long roll. He knew Nature's design.

"It was in order that you, Professor Frowenfeld, might become my vicar! Your book shall be in French! We must give it a wide scope! It shall contain valuable geographical, topographical, biographical, and historical notes. It shall contain complete lists of all the officials in the province (I don't say territory, I say province) with their salaries—and perquisites; ah! we will expose that! And—ha! I will write some political essays for it. Raoul shall illustrate it. Honoré shall give you money to publish it. Ah! Professor Frowenfeld, the star of your fame is rising out of the waves of oblivion! Come—I dropped in purposely to ask you—come across the street and take a glass of *tuffia* with Agricola Fusilier."

This crowning honor the apothecary was insane enough to decline, and Agricola went away with many professions of endearment, but secretly offended because Joseph had not asked about his wound.

All the same the apothecary, without loss of time, departed for the yellow-washed cottage, No. 19 rue Bienville.

"To-morrow, at four P. M.," he said to himself, "if the weather is favorable, I ride with M. Grandissime."

He almost saw his books and instruments look up at him reproachfully.

The ladies were at home. Aurora herself opened the door, and Clotilde came forward from the bright fire-place with a cordiality never, before so unqualified.

There was something about these ladies—in their simple, but noble grace, in their half-Gallic, half-classic beauty, in a jocund buoyancy mated to an amiable dignity—that made them appear to the scholar as though they had just bounded into life from the garlanded procession of some old fresco. The resemblance was not a little helped on by the costume of the late Revolution (most acceptably chastened and belated by the distance from Paris). Their black hair, somewhat heavier on Clotilde's head, where it rippled once or twice, was knotted *en Grecque*, and adorned only with the spoils of a nosegay given to Clotilde by a chivalric small boy in the home of her music-scholar.

"We was expectin' you since several days," said Clotilde, as the three sat down before the fire, Frowenfeld in a cushioned chair whose moth-holes had been carefully darned.

Frowenfeld intimated, with tolerable composure, that matters beyond his control had delayed his coming beyond his intention.

"You gedd'n' ridge," said Aurora, dropping her wrists across each other.

Frowenfeld, for once, laughed outright, and it seemed so odd in him to do so that both the ladies followed his example. The ambition to be rich had never entered his thought, although, in an unemotional, German way, he was prospering in a little city where wealth was daily pouring in, and a man had only to keep step, so to say, to march into possessions.

"You hought to 'ave a mo' larger sto' an' some clerque," pursued Aurora.

The apothecary answered that he was contemplating the enlargement of his present place or removal to a roomier, and that he had already employed an assistant.

"Oo it is, 'Sieur Frowenfel'?"

Clotilde turned toward the questioner a remonstrative glance.

"His name," replied Frowenfeld, betraying a slight embarrassment, "is—Innerarity; Mr. Raoul Innerarity; he is —"

"Ee pain' dad pigtu' w'at 'angin' in yo' window?"

Clotilde's remonstrance rose to a slight movement and a murmur.

Frowenfeld answered in the affirmative, and possibly betrayed the faint shadow of a smile. The response was a peal of laughter from both ladies.

"He is an excellent drug clerk," said Frowenfeld, defensively.

Whereat Aurora laughed again, leaning over and touching Clotilde's knee with one finger.

"An excellen' drug cl'—ha, ha, ha! oh!"

"You muz podden uz, M'sieu' Frowenfel'," said Clotilde, with forced gravity.

Aurora sighed her participation in the apology; and, a few moments later, the apothecary and both ladies (the one as fond of the abstract as the other two were ignorant of the concrete) were engaged in an animated, running discussion on art, society, climate, education,—all those large, secondary *desiderata* which seem of first importance to young ambition and secluded beauty, flying to and fro among these subjects with all the liveliness and uncertainty of a game of pussy-wants-a-corner.

Frowenfeld had never before spent such an hour. At its expiration, he had so well held his own against both the others, that the three had settled down to this sort of entertainment: Aurora would make an assertion, or Clotilde would ask a question; and Frowenfeld, moved by that frankness and ardent zeal for truth which had enlisted the early friendship of Doctor Keene, amused and attracted Honoré Grandissime, won the confidence of the f. m. c., and tamed the fiery distrust and enmity of Palmyre, would present his opinions without the thought of a reservation either in himself or his hearers. On their part, they would sit in deep attention, shielding their faces from the fire, and responding to enunciations directly contrary to their convictions with an occasional "yes-seh," or "ceddenly," or "of coze," or,—prettier affirmation still,—a solemn drooping of the eyelids, a slight compression of the lips, and a low, slow declination of the head.

"The bane of all Creole art-effort"—(we take up the apothecary's words at a point where Clotilde was leaning forward and slightly frowning in an honest attempt to comprehend his condensed English)—"the bane of all Creole art-effort, so far as I have seen it, is amateurism."

"Amateu—" murmured Clotilde, a little beclouded on the main word and distracted by a French difference of meaning, but planting an elbow on one knee in the genuineness of her attention, and responding with a bow.

"That is to say," said Frowenfeld, apologizing for the homeliness of his further explanation by a smile, "a kind of ambitious indolence that lays very large eggs, but can neither see the necessity for building a nest

beforehand, nor command the patience to hatch the eggs afterward."

"Of coze," said Aurora.

"It is a great pity," said the sermonizer, looking at the face of Clotilde, elongated in the brass andiron; and, after a pause: "Nothing on earth can take the place of hard and patient labor. But that, in this community, is not esteemed; most sorts of it are contemned; the humbler sorts are despised, and the higher are regarded with mingled patronage and commiseration. Most of those who come to my shop with their efforts at art, hasten to explain, either that they are merely seeking pastime, or else that they are driven to their course by want; and if I advise them to take their work back and finish it, they take it back and never return. Industry is not only despised, but has been degraded and disgraced, handed over into the hands of African savages."

"Doze Creole' is *lezzy*," said Aurora.

"That is a hard word to apply to those who do not *consciously* deserve it," said Frowenfeld; "but if they could only wake up to the fact,—find it out themselves——"

"Ceddenly," said Clotilde.

"'Sieur Frowenfel'," said Aurora, leaning her head on one side, "some pipple thing it is doze climade; 'ow you lag doze climade?"

"I do not suppose," replied the visitor, "there is a more delightful climate in the world."

"Ah-h-h!"—both ladies at once, in a low, gracious tone of acknowledgment.

"I thing Louisiana is a paradise-me!" said Aurora. "W'ere you goin' fin' sudge a h-air?" She respired a sample of it. "W'ere you goin' fin' sudge a so ridge groun'? De weed' in my bag yard is twenny-five feet 'igh!"

"Ah! maman!"

"Twenty-six!" said Aurora, correcting herself. "W'ere you fin' sudge a reever lag dad Mississippi? *On dit*," she said, turning to Clotilde, "*que ses eaux ont la propriété de contribuer même à multiplier l'espèce humaine*—ha, ha, ha!"

Clotilde turned away an unmoved countenance to hear Frowenfeld.

Frowenfeld had contracted a habit of falling into meditation whenever the French language left him out of the conversation.

"Yes," he said, breaking a contemplative pause, "the climate is *too* comfortable and the soil too rich,—though I do not think it is entirely on their account that the people

who enjoy them are so sadly in arrears to the civilized world." He blushed with the fear that his talk was bookish, and felt grateful to Clotilde for seeming to understand his simple speech.

"W'ad you fin' de rizzon is, 'Sieur Frowenfel'?" she asked.

"I do not wish to philosophize," he answered.

"*Mais*, go hon." "*Mais*, go ahade," said both ladies, settling themselves.

"It is largely owing," exclaimed Frowenfeld, with sudden fervor, "to a defective organization of society, which keeps this community, and will continue to keep it for an indefinite time to come, entirely unprepared and disinclined to follow the course of modern thought."

"Of coze," murmured Aurora, who had lost her bearings almost at the first word.

"One great general subject of thought now is human rights,—universal human rights. The entire literature of the world is becoming tinctured with contradictions of the dogmas upon which society in this section is built. Human rights is, of all subjects, the one upon which this community is most violently determined to hear no discussion. It has pronounced that slavery and caste are right, and sealed up the whole subject. What, then, will they do with the world's literature? They will coldly decline to look at it, and will become, more and more as the world moves on, a comparatively illiterate people."

"Bud, 'Sieur Frowenfel'," said Clotilde, as Frowenfeld paused,—Aurora was stunned to silence,—"*de Unitee State' goin' pud doze nigga free, aind it?*"

Frowenfeld pushed his hair hard back. He was in the stream now, and might as well go through.

"I have heard that charge made, even by some Americans. I do not know. But there is a slavery that no legislation can abolish,—the slavery of caste. That, like all the slaveries on earth, is a double bondage. And what a bondage it is which compels a community, in order to preserve its established tyrannies, to walk behind the rest of the intelligent world! What a bondage is that which incites a people to adopt a system of social and civil distinctions, possessing all the enormities and none of the advantages of those systems which Europe is learning to despise! This system, moreover, is only kept up by a flourish of weapons. We have here what you may call an armed aristocracy. The class over which

these instruments of main force are held is chosen for its servility, ignorance, and cowardice; hence, indolence in the ruling class. When a man's social or civil standing is not dependent on his knowing 'how to read, he is not likely to become a scholar."

"Of coze," said Aurora, with a pensive respiration, "I thing id is doze climade," and the apothecary stopped, as a man should who finds himself unloading large philosophy in a little parlor.

"I thing, me, dey hought to pud doze quadroon free?" It was Clotilde who spoke, ending with the rising inflection to indicate the tentative character of this daringly premature declaration.

Frowenfeld did not answer hastily.

"The quadroons," said he, "want a great deal more than mere free papers can secure them. Emancipation before the law, though it may be a right which man has no right to withhold, is to them little more than a mockery until they achieve emancipation in the minds and good will of the people—the people, did I say? I mean the ruling class." He stopped again. One must inevitably feel a little silly, setting up tenpins for ladies who are too polite, even if able, to bowl them down.

Aurora and the visitor began to speak simultaneously; both apologized, and Aurora said:

"'Sieur Frowenfel', w'en I was a lill' girl,"—and Frowenfeld knew that he was going to hear the story of Palmyre. Clotilde moved, with the obvious intention to mend the fire. Aurora asked, in French, why she did not call the cook to do it, and Frowenfeld said, "Let me,"—threw on some wood, and took a seat nearer Clotilde. Aurora had the floor.

CHAPTER XXV.

AURORA AS A HISTORIAN.

ALAS! the phonograph was invented three-quarters of a century too late. If type could entrap one-half the pretty oddities of Aurora's speech,—the arch, the pathetic, the grave, the earnest, the matter-of-fact, the ecstatic tones of her voice,—nay, could it but reproduce the movement of her hands, the eloquence of her eyes, or the shapings of her mouth,—ah! but type—even the phonograph—is such an inadequate thing! Sometimes she laughed; sometimes Clotilde, unexpectedly to herself, joined her; and twice or thrice she provoked a similar

demonstration from the ox-like apothecary,—to her own intense amusement. Sometimes she shook her head in solemn scorn; and, when Frowenfeld, at a certain point where Palmyre's fate locked hands for a time with that of Bras-Coupé, asked a fervid question concerning that strange personage, tears leaped into her eyes, as she said:

"Ah! 'Sieur Frowenfel', iv I tra to tell de sto'y of Bras-Coupé, I goin' to cry lag a lill' bobby."

The account of the childhood days upon the plantation at Cannes Brulée may be passed by. It was early in Palmyre's fifteenth year that that Kentuckian, 'mutual friend' of her master and Agricola, prevailed with M. de Grapion to send her to the paternal Grandissime mansion,—a complimentary gift, through Agricola, to Mademoiselle, his niece,—returnable ten years after date.

The journey was made in safety; and, by and by, Palmyre was presented to her new mistress. The occasion was notable. In a great chair in the center sat the *grand-père*, a Chevalier de Grandissime, whose business had narrowed down to sitting on the front verandah and wearing his decorations,—the cross of St. Louis being one; on his right, Colonel Numa Grandissime, with one arm dropped around Honoré, then a boy of Palmyre's age, expecting to be off in sixty days for France; and on the left, with Honoré's fair sister nestled against her, "Madame Numa," as the Creoles would call her, a stately woman and beautiful, a great admirer of her brother Agricola. (Aurora took pains to explain that she received these minutæ from Palmyre herself in later years.) One other member of the group was a young don of some twenty years' age, not an inmate of the house, but only a cousin of Aurora on her deceased mother's side. To make the affair complete, and as a seal to this tacit Grandissime-de Grapion treaty, this sole available representative of the "other side" was made a guest for the evening. Like the true Spaniard that he was, Don José Martinez (whose initials the reader will remember seeing on Honoré's saddle) fell deeply in love with Honoré's sister. Then there came Agricola leading in Palmyre. There were others, for the Grandissime mansion was always full of Grandissimes; but this was the central group.

In this house Palmyre grew to womanhood, retaining without interruption the place into which she seemed to enter by

right of indisputable superiority over all competitors,—the place of favorite attendant to the sister of Honoré. Attendant, we say, for servant she never seemed. She grew tall, arrowy, lithe, imperial, diligent, neat, thorough, silent. Her new mistress, though scarcely at all her senior, was yet distinctly her mistress; she had that through her Fusilier blood; experience was just then beginning to show that the Fusilier Grandissime was a superb variety; she was a mistress one could wish to obey. Palmyre loved her, and through her contact ceased, for a time at least, to be the pet leopard she had been at the Cannes Brulée.

Honoré went away to Paris only sixty days after Palmyre entered the house. But even that was not soon enough.

"'Sieur Frowenfel'," said Aurora, in her recital, "Palmyre, she never tole me dad, *mais* I am shoe, *shoe* dad she fall in love wid Honoré Grandissime. 'Sieur Frowenfel', I thing dad Honoré Grandissime is one bad man, ent it? Whad you thing, 'Sieur Frowenfel'?"

"I think, as I said to you the last time, that he is one of the best, as I know that he is one of the kindest and most enlightened gentlemen in the city," said the apothecary.

"Ah, 'Sieur Frowenfel'! ha, ha!"

"That is my conviction."

The lady went on with her story.

"Hanny'ow, I know she *continue* in love wid 'im all doze ten year' w'at 'e been gone. She baig Mademoiselle Grandissime to wrad dad ledder to my papa to ass to kip her two years mo'."

Here Aurora carefully omitted that episode which Doctor Keene had related to Frowenfeld,—her own marriage and removal to Fausse Rivière, the visit of her husband to the city, his unfortunate and finally fatal affair with Agricola, and the surrender of all her land and slaves to that successful duelist.

M. de Grapion, through all that, stood by his engagement concerning Palmyre; and, at the end of ten years, to his own astonishment, responded favorably to a letter from Honoré's sister, irresistible for its goodness, good sense, and eloquent pleading, asking leave to detain Palmyre two years longer; but this response came only after the old master and his pretty, stricken Aurora had wept over it until they were weak and gentle,—and was not a response either, but only a silent consent.

Shortly before the return of Honoré—and here it was that Aurora took up again the thread of her account—while his mother,

long-widowed, reigned in the paternal mansion, with Agricola for her manager, Bras-Coupé appeared. From that advent and the long and varied mental sufferings which its consequences brought upon her, sprang that second change in Palmyre, which made her finally untamable, and ended in a manumission, granted her more for fear than for conscience' sake. When Aurora attempted to tell those experiences, even leaving Bras-Coupé as much as might be out of the recital, she choked with tears at the very start, stopped, laughed, and said:

"*C'est tout*—daz all. 'Sieur Frowenfel', oo you fine dad pigtu' to loog lag, yonnah, hon de wall?"

She spoke as if he might have overlooked it, though twenty times, at least, in the last hour, she had seen him glance at it.

"It is a good likeness," said the apothecary, turning to Clotilde, yet showing himself somewhat puzzled in the matter of the costume.

The ladies laughed.

"Daz ma grade-gran'-mamma," said Clotilde.

"Dass one *fille à la cassette*," said Aurora, "my gran'-muzzah; *mais*, ad de sem tam id is Clotilde." She touched her daughter under the chin with a ringed finger. "Clotilde is my gran'-mamma."

Frowenfeld rose to go.

"You muz come again, 'Sieur Frowenfel'," said both ladies, in a breath.

What could he say?

CHAPTER XXVI.

A RIDE AND A RESCUE.

"DOUANE or Bienville?"

Such was the choice presented by Honoré Grandissime to Joseph Frowenfeld, as the former on a lively brown colt and the apothecary on a nervy chestnut, fell into a gentle, preliminary trot while yet in the rue Royale, looked after by that great admirer of both, Raoul Innerarity.

"Douane?" said Frowenfeld. (It was the street we call Custom-house.)

"It has mud-holes," objected Honoré.

"Well, then, the rue du Canal?"

"The canal—I can smell it frhom heah. Why not rhue Bienville?"

Frowenfeld said he did not know. (We give the statement for what it is worth.)

Notice their route. A spirit of perversity seems to have entered into the very topography of this quarter. They turned up the

rue Bienville (up is toward the river); reaching the levee, they took their course up the shore of the Mississippi (almost due south), and broke into a lively gallop on the Tchoupitoulas road, which in those days skirted that margin of the river nearest the sunset, namely, the *eastern* bank.

Conversation moved sluggishly for a time, halting upon trite topics or swinging easily from polite inquiry to mild affirmation, and back again. They were men of thought, these two, and one of them did not fully understand why he was in his present position; hence some reticence. It was one of those afternoons in March that make one wonder how the rest of the world avoids emigrating to Louisiana in a body.

"Is not the season early?" asked Frowenfeld.

M. Grandissime believed it was; but then the Creole spring always seemed so, he said.

The land was an inverted firmament of flowers. The birds were an innumerable, busy, joy-compelling multitude, darting and fluttering hither and thither, as one might imagine the babes do in heaven. The orange-groves were in blossom; their dark green boughs seemed snowed upon from a cloud of incense, and a listening ear might catch an incessant, whispered trickle of falling petals, dropping "as the honey-comb." The magnolia was beginning to add to its dark and shining evergreen foliage frequent sprays of pale new leaves and long, slender, buff buds of others yet to come. The oaks, both the bare-armed and the "green-robed senators," and the willows, the plaquemini-ers and the giant pecans, were putting out their subdued florescence as if they smiled in grave participation with the laughing gardens. The homes that gave perfection to this beauty were those old, large, belverided colonial villas, of which you may still here and there see one standing, battered into half ruin, high and broad, among foundries, cotton and tobacco-sheds, junk-yards, and long-shoremen's hovels, like one unconquered elephant in a wreck of artillery. In Frowenfeld's day the "smell of their garments was like Lebanon." They were seen by glimpses through chance openings in lofty hedges of Cherokee rose or bois-d'arc, under boughs of cedar or pride-of-China, above their groves of orange or down their long, over-arched avenues of oleander; and the lemon and the pomegranate, the banana, the fig, the shaddock, and at times even the mango and the guava, joined "hands around" and tossed their fragrant locks

above the lilies and roses. Frowenfeld forgot to ask himself further concerning the probable intent of M. Grandissime's invitation to ride; these beauties seemed rich enough in good reasons. He felt glad and grateful.

At a certain point the two horses turned of their own impulse, as by force of habit, and with a few clambering strides mounted to the top of the levee and stood still, facing the broad, dancing, hurrying, brimming river.

The Creole stole an amused glance at the elated, self-forgetful look of his immigrant friend.

"Mr. Frhowenfeld," he said, as the delighted apothecary turned with unwonted suddenness and saw his smile, "I believe you like this bettah than discussion. You find it easieh to be in hahmony with Louisiana than with Louisianians, eh?"

Frowenfeld colored with surprise. Something unpleasant had lately occurred in his shop. Was this to signify that M. Grandissime had heard of it?

"I am a Lousianian," replied he, as if this were a point assailed.

"I would not insinuate othehwise," said M. Grandissime, with a kindly gesture. "I would like you to feel so. We ah citizens now of a differhent gove'ment to that unde which we lived the mawning we first met. Yet"—the Creole paused and smiled—"you ah not, and I am glad you ah not, what we call a Lousianian."

Frowenfeld's color increased. He turned quickly in his saddle as if to say something very positive, but hesitated, restrained himself and asked:

"Mr. Grandissime, is not your Creole 'we' a word that does much damage?"

The Creole's response was at first only a smile, followed by a thoughtful countenance; but he presently said, with some suddenness:

"My-de'-seh, yes. Yet you see I am, even this moment, fo'getting we ah not a separhate people. Yes, ow Crheole 'we' does damage, and ow Crheole 'you' does mo'. I assu' you, seh, I trhy hahd to get my people to unde'stand that it is time to stop calling those who come and add themselves to the community, aliens, intehlopehs, invadehs. That is what I heah my cousins, 'Polyte and Sylvestre, in the heat of discussion, called you the otheh evening; is it so?"

"I brought it upon myself," said Frowenfeld. "I brought it upon myself."

"My-de'-seh," interrupted M. Grandis-

sime, with a broad smile, "excuse me—I am fully prhepa'ed to believe it. But the chahge is a false one. I told them so. My-de'-seh—I know that a citizen of the United States in the United States has a rright to become, and to be called, unde the laws gove'ning the case, a Louisianian, a Veh-monter-h or a Vi'ginian, as it may suit his whim; and even if he should be found dishonest aw dangerous, he has a rright to be threated jus' ezactly as we threat the knaves and rhuffians who ah native bawn! Everhy discrheet man must admit that."

"But if they do not enforce it, Mr. Grandissime," quickly responded the sore apothecary, "if they continually forget it—if one must surrender himself to the errors and crimes of the community as he finds it —"

The Creole uttered a low laugh.

"Pahty differhences, Mr. Frhownfeld; they have them in all countrihies."

"So your cousins said," said Frowenfeld.

"And how did you answeh them?"

"Offensively," said the apothecary, with sincere mortification.

"Oh! that was easy," replied the other, amusedly; "but how?"

"I said that, having here only such party differhences as are common elsewhere, we do not behave as they elsewhere do; that in most civilized countries the immigrant is welcome, but here he is not. I am afraid I have not learned the art of courteous debate," said Frowenfeld, with a smile of apology.

"'Tis a grheat aht," said the Creole, quietly, stroking his horse's neck. "I suppose my cousins denied yo' statement with indignation, eh?"

"Yes; they said the honest immigrant is always welcome."

"Well, do you not find that trhue?"

"But, Mr. Grandissime, that is requiring the immigrant to prove his innocence!" Frowenfeld spoke from the heart. "And even the honest immigrant is welcome only when he leaves his peculiar opinions behind him. Is that right, sir?"

The Creole smiled at Frowenfeld's heat.

"My-de'-seh, my cousins complain that you advocate measu'es fatal to the prhe-vailing order-h of society."

"But," replied the unyielding Frowenfeld, turning redder than ever, "that is the very thing that American liberty gives me the right—peaceably—to do! Here is a structure of society defective, dangerous, erected

on views of human relations which the world is abandoning as false; yet the immigrant's welcome is modified with the warning not to touch these false foundations with one of his fingers!"

"Did you tell my cousins the foundations of society here-h ah false?"

"I regret to say I did, very abruptly. I told them they were privately aware of the fact."

"You may say," said the ever-amiable Creole, "that you allowed debate to rhun into contrhovehcy, eh?"

Frowenfeld was silent; he compared the gentleness of this Creole's rebukes with the asperity of his advocacy of right and felt humiliated. But M. Grandissime spoke with a rallying smile.

"Mr. Frhownfeld, you nevva make pills with eight cawnehs, eh?"

"No, sir." The apothecary smiled.

"No, you make them rhound; cannot you make yo' doctrhines the same way? My-de'-seh, you will think me impertinent; but the rreason I speak is because I wish verhy much that you and my cousins would not be offended with each otheh. To tell you the thruth, my-de'-seh, I hoped to use you with them—pahdon my frhankness."

"If Louisiana had more men like you, M. Grandissime," cried the untrained Frowenfeld, "society would be less sore to the touch."

"My-de'-seh," said the Creole, laying his hand out toward his companion and turning his horse in such a way as to turn the other also, "do me one favah; rhemembek that it is so' to the touch."

The animals picked their steps down the inner face of the levee and resumed their course up the road at a walk.

"Did you see that man just turn the bend of the rhoad, away yondah?" the Creole asked.

"Yes."

"Did you rheco'nize him?"

"It was—my landlord, wasn't it?"

"Yes. Did he not have a convassation with you lately, too?"

"Yes, sir; why do you ask?"

"It has had a bad effect on him. I wondeh why he is out here-h on foot?"

The horses quickened their paces. The two friends rode along in silence. Frowenfeld noticed his companion frequently cast an eye up along the distant sunset shadows of the road with a new anxiety. Yet, when M. Grandissime broke the silence it was only to say:

"I suppose you find the blemishes in our state of society can all be attributed to one main defect, Mr. Frhownfeld?"

Frownfeld was glad of the chance to answer:

"I have not overlooked that this society has disadvantages as well as blemishes; it is distant from enlightened centers; it has a language and religion different from that of the great people of which it is now called to be a part. That it has also positive blemishes of organism —"

"Yes," interrupted the Creole, smiling at the immigrant's sudden magnanimity, "its positive blemishes; do they all spring from one main defect?"

"I think not. The climate has its influence, the soil has its influence—dwellers in swamps cannot be mountaineers."

"But after-h all," persisted the Creole, "the grheateh part of ow throubles comes frhom —"

"Slavery," said Frownfeld, "or rather, caste."

"Exactly," said M. Grandissime.

"You surprise me, sir," said the simple apothecary. "I supposed you were —"

"My-de'-seh," exclaimed M. Grandissime, suddenly becoming very earnest, "I am nothing, nothing! There-h is which you have the advantage of me. I am but a *diletante*, whether-h in politics, in philosophy, morhals, aw rheligion. I am afraid to go deeply into anything, lest it should make rhuin in my name, my family, my prhoph'e'ty."

He laughed unpleasantly.

The question darted into Frownfeld's mind, whether this might not be a hint of the matter that M. Grandissime had been trying to see him about.

"Mr. Grandissime," he said, "I can hardly believe you would long neglect a duty either for family, property, or society."

"Well, you mistake," said the Creole, so coldly that Frownfeld colored.

They galloped on. M. Grandissime brightened again, almost to the degree of vivacity. By and by they slackened to a slow trot and were silent. The gardens had been long left behind, and they were passing between continuous Cherokee rose-hedges on the right, and on the left along that bend of the Mississippi where its waters, glancing off three miles above from the old De Macarty levee (now Carrollton), at the slightest opposition in the breeze go whirling and leaping like a herd of dervishes across to the ever-crumbling shore, now marked by the little yellow

depot-house of Westwego. Miles up the broad flood the sun was disappearing gorgeously. From their saddles, the two horse men feasted on the scene, without comment.

But, presently, M. Grandissime uttered a low ejaculation and spurred his horse toward a tree hard by, preparing, as he went, to fasten his rein to an overhanging branch. Frownfeld, agreeable to his beckon, imitated the movement.

"I feah he intends to drhown himself," whispered M. Grandissime, as they hurriedly dismounted.

"Who? Not —"

"Yes, yo' lan'lawd, as you call him. He is on the flat; I saw his hat over the levee. When we get on top the levee, we must get right into it. But do not follow him into the wateh in frhont of the flat; it is certain death; no power-h of man could keep you frhom going under-h it."

The words were quickly spoken; they scrambled to the levee's crown. Just abreast of them lay a "flatboat," emptied of its cargo and moored to the levee. They leaped into it. A human figure swerved from the onset of the Creole and ran toward the bow of the boat, and in an instant more would have been in the river.

"Stop!" said Frownfeld, seizing the unresisting f. m. c. firmly by the collar.

Honoré Grandissime smiled, partly at the apothecary's brief speech, but much more at his success.

"Let him go, Mr. Frhownfeld," he said, as he came near.

The silent man turned away his face with a gesture of shame.

M. Grandissime, in a gentle voice, exchanged a few words with him, and he turned and walked away, gained the shore, descended the levee, and took a foot-path which soon hid him beyond a hedge.

"He gives his pledge not to trhy again," said the Creole, as the two companions proceeded to resume the saddle. "Do not look afteh him." (Joseph had cast a searching look over the hedge.)

They turned homeward.

"Ah! Mr. Frhownfeld," said the Creole, suddenly, "if the *imnygrhant* has cause of complaint, how much mo' has *that* man! Trhue, it is only love fo' which he would have jus' now drhowned himself; yet what an accusation, my-de'-seh, is his whole life against that 'caste' which shuts him up within its narrow and almost solitary limits! And yet, Mr. Frhownfeld, this people esteem this very same crhime of caste the

holiest and most precious of their virtues. My-de'-seh, it never-h occu's to us that in this matten we are interested, and theffo' disqualified, witnesses. We say we ah not unde'stood; that the jurhy (the civilized world) rhendehs its decision without viewing the body; that we are judged from a distance. We fo'get that we owselves ah too *close* to see distinctly, and so continue, a spectacle to civilization, sitting in a horrible dahkness, my-de'-seh!" He frowned.

"The shadow of the Ethiopian," said the grave apothecary.

M. Grandissime's quick gesture implied that Frowenfeld had said the very word.

"Ah! my-de'-seh, when I trhy sometime' to stan' outside an' look at it, I am *am-d-aze* at the length, the breadth, the blackness of that shadow!" (He was so deep in earnest that he took no care of his English.) "It is the *Némésis* w'ich, instead of coming afteh, glides along by the side of this moral, political, commersial, social mistake! It blanches, my-de'-seh, ow whole civilization! It drhags us a centurhy behind the rhes' of the world! It rhetahds and poisons everhy industrhy we got!—mos' of all our-h

immense agrhicultu'e! It brheeds a thousan' cusses that nevva leave home but jus' flutter-h up an' rhoost, my-de'-seh, on ow *heads*; an' we nevva know it!—yes, sometimes some of us know it."

He changed the subject.

They had repassed the ruins of Fort St. Louis, and weré well within the precincts of the little city, when, as they pulled up from a final gallop, mention was made of Doctor Keene. He was improving; Honoré had seen him that morning; so, at another hour, had Frowenfeld. Doctor Keene had told Honoré about Palmyre's wound.

"You was at heh house again this mawning?" asked the Creole.

"Yes," said Frowenfeld.

M. Grandissime shook his head warningly.

"'Tis a dangerhous business. You are-h almost su'e to become the object of slandeh. You ought to tell Docteh Keene to make some other-h arrhangement, aw prhesently you, too, will be undeh the—" he lowered his voice, for Frowenfeld was dismounting at the shop door, and three or four acquaintances stood around—"undeh the 'shadow of the Ethiopian.'"

(To be continued.)

EXTRACTS FROM THE JOURNAL OF HENRY J. RAYMOND. III.

(EDITED BY HIS SON.)

REMINISCENCES OF 1863, AND THE QUESTION OF FRENCH INTERVENTION.

THE second of these papers (SCRIBNER for January), it will be remembered, included my father's account of the failure of the Burnside campaign before Fredericksburg and the causes assigned for it at head-quarters. The pages here given relate to the subsequent events which culminated in the appointment of Gen. Hooker, with impressions of Washington life at that period. The opinions and statements in regard to French intervention possess peculiar interest to those who recall the gloom of those dark days in 1863. And when it is remembered how much the executive branch of the government had to contend with—factions in the camp and at home, discontented critics button-holing members of the administration to listen to their personal grievances; politicians seeking to influence military movements in favor of their own partisan and selfish schemes; allies of the enemy fomenting discord

throughout the North; selfishness too often superseding a desire for the safety of the commonwealth, and foreign nations invited and urged to take part in our struggle, to dictate terms of settlement, to demand disruption as the price of peace—considering all these things, how is our admiration increased for the President and Cabinet who patiently, firmly, confidently met all complaints and cavils, anticipated difficulties, thwarted secret foes, and finally carried the nation triumphantly through all its troubles, and saved us as the United States.

The entries in the journal continue to be made in the field with the Army of the Potomac.

"January 24th, 1863. At half past 12, General Burnside called to Doctor Church and myself, who were walking in front of headquarters, and asked us in. He turned to us after we were seated and said: '*I'm not going to resign.* I'll put the thing in such

a shape that the government and country can't misunderstand it. It is time to see whether patriotism or unprincipled selfishness rules the country." He then asked his secretary to read me an order he had just dictated. It recited that General Hooker had dealt in unnecessary and unjust criticisms of his superior officers; that he had forwarded exaggerated and untrue reports to headquarters, calculated to deceive the commanding General; that he was in the habit of talking harshly and abusively of all in authority over him, to the scandal and the serious injury of the service; and then *dismissed him from the service of the United States as unfit to hold a command in a cause where so much of moderation, forbearance, and unselfish patriotism were required.* This order was, of course, subject to the approval of the President. He asked me what I thought of it. I asked him if he was sure of his ground. He said he could prove everything he had stated. I then said I thought it was the best step taken during the war,—that it could not fail to have an excellent effect upon both the army and the country, if followed up by acts of corresponding vigor. He said he should prepare orders at once relieving Franklin, W. F. Smith, Sturgis, Woodbury, Newton and Cochrane from their commands. He was satisfied this was the proper course to be pursued. He left his secretary to copy these orders.

General Burnside stated to the Congressional Investigating Committee, that he had become satisfied that it was absolutely necessary that some such examples should be made, in order to enable him to maintain the proper authority over the army under his command. He also said to the committee:

"I told my Adjutant-General to issue that order (No. 8) at once. One of my advisers—only two persons [Doctor Church and my father] knew of this—one of them, who is a very cool, sensible man, and a firm friend, told me that, in his opinion, the order was a just one, and ought to be issued; but he said that he knew my views with reference to making myself useful to the Government, instead of placing myself in opposition to it; that all of these things had to be approved by the President at any rate before they could be put in force; that he did not think I intended to place the President in a position where he had either to assume the responsibility of becoming my enemy before the public, at any rate, thereby enabling a certain portion of my friends to make a martyr of me to some extent, or else to take the responsibility of carrying out the order, which would be against the views of a great many of the most influential men in the country, particularly that portion in reference to the officers I proposed to have dismissed the service. * * * I took this order, already signed and issued in due form with the exception of publication, to the President, and handed it to him, together with my resignation of my commission as Major-General."

To resume the narrative of the journal:

"When we were outside, I said it was desirable, of course, to look at all sides of the question, and to contemplate all contingencies. Suppose that General Hooker should attempt to raise a mutiny among his troops on the promulgation of the order: what then? He said he would *swing him* before

sundown, if he attempted such a thing. I then said I didn't suppose he would make the attempt, but it was well enough to think of it. I was satisfied he (General B.) was on the right track.

"At eight in the evening the general said to me that he was going to Washington, and asked me to go with him. I asked him what took him there. He said that General Parks and Doctor Church were startled at the boldness of the action he proposed to take, and thought it would be more prudent for him to consult the authorities before deciding upon it. He said he should see only the President. He had telegraphed to him that he would be there by one o'clock and would detain him only an hour. He should submit to him the orders he proposed to issue, and leave him to say whether he should issue them or not. He asked what I thought would be the result. I told him the orders would not be issued. He thought he could satisfy the President of the necessity of such action.

"At half-past eight we started in an ambulance for the station at Falmouth, three miles off. The night was dark, and the obscurity was increased by a dense fog. The road was very muddy, and as it led through open fields we soon lost it and found ourselves plunging down a steep hill in an old cornfield. We stopped, dismounted, and began to hunt for the road. A horseman loomed through the fog. The General hailed him, and asked him where the road was. He said he didn't know; he was lost, also. The General, without telling him who he was, told him to turn and ride to a camp, the light of which was shining in the fog, and find out the way. The man answered that he was going to headquarters with despatches for General Burnside. 'Turn about and do as I tell you,' said the General, still not revealing himself. The man hesitated a moment, and finally started off, shouting, 'I am going to attend to my own business, and I advise you to do the same.' We resumed our search, found the road, lost it again, stumbled over four or five dead mules and an upset caisson; and, after plunging about in the mud for three hours, reached the station. The special engine which the General had ordered was gone, having been sent for to Stoneman's Station to haul a car upon the track. We spent half an hour trying to get telegraphic communication with the latter place, and finally started on foot for a three-mile walk. The General took the lead, carrying a lantern, I followed, and then came the General's secretary and his servant. We had gone two miles or so when we met the engine. The General succeeded in stopping it by swinging the lantern. We mounted, stopped at Stoneman's long enough to wake up the telegraph operator, took him along for consignment to the guard-ship, found a steamboat in readiness at Acquia, and reached Washington at six o'clock in the morning.

"General Burnside left me at Willard's, while he went to the White House. At about nine A. M. he sent in for me, and we breakfasted in a private room. He said his announcement to the President of the orders he intended to issue had come upon him like a clap of thunder, and he was very doubtful as to the result. He intended to return at once to the army, and would apprise me of the conclusion of the matter by telegraph. He left at half-past ten. I immediately called upon Secretary Chase and told him the whole story. He was greatly surprised to hear such reports of Hooker, and said he had looked upon him as probably the man best fitted to command the Army of the Potomac. But no man capable of so much selfish and unprincipled ambition was fit for so great a trust, and he gave up all thought of him hence-

forth. He asked me to go with him to his house and accompany him and his daughter to the President's levee. I did so, and found a great crowd surrounding Mr. Lincoln. I managed, however, in brief terms, to tell him that I had been with the army, and that many things were occurring there which he ought to know. I told him of the obstacles thrown in Burnside's way by his subordinates, and especially of General Hooker's habitual conversation. He put his hand on my shoulder and said in my ear, as if desirous of not being overheard, 'That is all true—Hooker does talk badly; but the trouble is, he is stronger with the country to-day than any other man.' I ventured to ask him how long he would retain that strength when his real conduct and character should be understood. 'The country,' he answered, 'would not believe it; they would say it is all a lie.'

"I next called at the State Department, and found that, although it was a day for receiving none but foreign ministers, word had been left at the door for my admission. I found Mr. Seward very anxious to know all about the state of things in the army. I told him all I knew, and said I thought the mass of the army was loyal and sound, and that the whole demoralization was with the officers. I dwelt considerably upon what seemed to me the main characteristics of Burnside's mind and character, and answered all his questions, which were many and minute, as well as I could. He finally asked if I was satisfied with Burnside as commander of that army. I told him that this question involved very many military considerations of which I was not a competent judge. He said I was as good a judge as he was, and he was *obliged* to have an opinion. I told him then that, according to my best judgment, it was advisable to have Burnside in command and to give him all the powers that belonged to that position. He talked a good deal about foreign affairs, which he said were in a perfectly satisfactory condition, and asked me to dine with him, but a previous engagement with Mr. Chase rendered it impossible for me to do so.

"In the evening I dined at Secretary Chase's, where I found Gov. Andrew, of Mass., Mr. Odell, M.C. from Brooklyn, a bright and talkative Mrs. N— from Philadelphia, and Miss Kate Chase, bright, lively, and agreeable. The Secretary was exceedingly solicitous for the success of his bank project, which he deemed absolutely essential to the management of the finances for the war. I ventured to ask him how the Government proposed to supply the places of the soldiers whose time of service would expire in the spring. He said he did not think they had any plan, and that the only way he could think of was by enlisting the negroes. I asked him if he supposed they could be obtained in sufficient numbers. He very lightly thought they could. Gov. Andrew had very little to say on the subject.

"*Sunday, 25.* * * * At dinner I fell in with Mr. Bancroft, who was greatly disturbed by the unpromising condition of affairs in the army and in the country, and thought it important that Gen. Hooker should be put in command. I explained to him my views of affairs, and told him I thought things would go right if the Government would simply say *no* to Burnside's proposal to resign, and then leave him to the free exercise of his official powers.

"Collector Barney of N. Y. came and sat by us, and told me that he had positive evidence that Mr. Greeley had been in correspondence with Vallandigham of Ohio on the subject of foreign mediation. He had heard of his having written him letters on the subject and on going to the 'Tribune' office

to make inquiries on the subject, had been told by Mr. —, Greeley's chief assistant, that such was the fact, and that Greeley had become so alarmed about the war that he was determined to have it ended on any terms.

[That this statement that Mr. Greeley sought foreign mediation to terminate the war was true finds confirmatory evidence in a later entry in this journal, which reads :

"On the way up to Albany I had Greeley for a fellow passenger. In the course of conversation *he said* he meant to carry out the policy of foreign mediation and of bringing the war to a close. 'You'll see,' said he, 'that I'll drive Lincoln into it.' On the way down, Mr. Hall, who is one of the Trustees of the 'Tribune' Association, told me that they would not permit Greeley to continue the advocacy of this policy in the paper. It was injurious in the highest degree.]

"S. B. Ruggles was very urgent for the passage of the bill to enlarge the locks on the Erie Canal, and to build a canal from Lake Michigan to the Mississippi as a means of consolidating the union of the North and West. He talked with great enthusiasm and eloquence in support of the project which was pending in Congress, and which met its most formidable opposition from two New York members, one Roscoe Conkling, living at Utica, on the Erie Canal, and the other his brother, Frederick A. Conkling, living in New York City, which would receive more direct benefit from such a work than any other locality in the country.

"*Monday, 26th.* I had an after-dinner sitting in Mr. Ruggles's rooms with Secretaries Seward and Usher, Senator Foster of Connecticut, Doctor Bellows, George Bancroft, General McDowell, and others. Mr. Seward discoursed at large and with great interest on the condition of the country. He seemed a little alarmed at the Democratic victories in the North, mainly because they seemed to indicate a disposition to deal harshly, instead of charitably with the administration, and to consider the rights of individual citizens of more importance than the salvation of the nation. He said he had originally opposed making an issue with the South on Fort Sumter, because it could not be reinforced, and the failure to take it would inspire the whole South, and bring them all into the secession movement. But he said we could hold Fort Pickens, Fort Pulaski, Fort Taylor, and the other forts below New Orleans, and he thought we ought to do so at all hazards—making the issue upon them, and throwing upon the South the burden of taking them from us, instead of assuming the aggressive ourselves. He still thought that would have been the wisest course. When Fort Taylor was invested, General Scott had told them that it could not be held, unless the *habeas corpus* was suspended in the town, which was full of secessionists, who were constantly aiding the rebels. Mr. Seward said he drew an order suspending it and took it to the President, explaining the circumstances of the case, and telling him that it seemed to be a necessary though a very important and responsible act. Mr. Lincoln, after some little discussion, said: 'Well, here goes, if you say so,' and signed the order. This was the first case in which that writ was suspended.

"As to the issuing of the Proclamation, Mr. Seward said he had simply delayed it for twenty days. The President had proposed to issue it when

he first heard of the crossing of the Potomac by the rebel army, and of their appearance in Maryland and Pennsylvania. Mr. Seward told him he thought it would look better to expel the rebels from free soil before undertaking to abolish slavery in the Southern states. Mr. Lincoln yielded to this reasoning, and postponed the issue of the proclamation until after the battle of Antietam.

"Mr. Chase, while in New York, told me rather a curious anecdote of this incident. He said that the President came into the meeting of the Cabinet after that battle (Antietam), and said he had come across something very amusing in one of Artemus Ward's letters and he read it through for the edification of the Secretaries. He then said he had brought another document to read to them—not for their advice and criticism for his mind was fully made up on the subject, but for their information. It was the Proclamation of Emancipation. He said he had promised himself (and his God) that if the rebels were driven out of Maryland, he would issue such a proclamation, and he was about to do it. Mr. Chase said the words, 'and my God' were uttered in a low tone, and he thought no one but himself heard them. Some days after he recalled them to the President's notice, and told him it seemed to him to indicate that he had issued the Proclamation in the fulfillment of a religious vow. The President half assented to the inference which Mr. Chase had drawn.

"Mr. Seward talked very freely of our foreign relations. At the outset of the war, he said, every foreign minister in Washington except Baron Gerolt, the Prussian minister, sympathized with secession in one way and another. His views had been changed, until now they were all solicitous to avoid giving us any offense, and anxious to maintain the most friendly relations. France had withdrawn her fleet from the mouth of the Mississippi, and had dismissed her consul at New Orleans, who had made himself offensive to us by aiding the rebels. England evinced in various ways her kindly feelings, and now asked as favors concessions she had hitherto demanded as rights. As an instance of this he mentioned that an officer of the British army, Major Winnie, had been taken at Point of Rocks coming into our lines without authority. He was in prison and was to be tried by court-martial as a spy. Lord Lyons had urged his release several times, but this had been refused. He had finally promised to put a stop to the frequent visits of English officers to the rebel armies, and in consideration of this Mr. Seward had agreed that the officer should be tried, but immediately pardoned. He recited several other instances illustrating the changed disposition of the English Government. And now (said Mr. Seward) just when we have with great difficulty established these relations with foreign powers and given them most distinctly to understand that intervention in any form will not be tolerated, Mr. Greeley comes forward, holds private interviews and opens a correspondence with the French minister to persuade him that the people would welcome a mediation which should terminate the war! Mr. Seward showed a great deal of indignation at this mischievous interference with our foreign relations, and expressed fears that it might produce very serious and injurious results. Mr. Greeley, he said, had rendered himself clearly and unmistakably liable to the penalties of the law forbidding all such intercourse with foreign ministers; but his own personal relations with him would render it impossible for him to take any steps in the matter,

as it would be charged to personal hostility on his part. Secretary Usher (of the Interior Department) thought this consideration ought not to interfere with his discharge of a public duty. He said the arrest of Mr. Greeley would do great good by satisfying the people that the government meant to punish all violations of law and all departures from loyalty, with impartial vigor. Mr. Seward indulged in a good deal of lively ridicule of Mr. Greeley's proposition to make Switzerland the arbiter of our destiny,—a republic half Prussian and half French, half catholic and half protestant, held together only by outward pressure, and represented at Washington by a Consul-General who kept a "Flour and Feed store" near the Capitol, and who knew no more of the necessities and conditions of our national existence than he did of the politics of the moon. Mr. Bancroft, who had fallen asleep during the more serious part of the Secretary's exposition, awoke at this sally and expressed the opinion that it would be much better to ridicule Mr. Greeley out of crochets than to send him to Fort Lafayette. The rest of the company, however, thought the matter one of too much gravity for such treatment. Mr. Seward said that Mr. Mercier (the French minister) knew Mr. Greeley as a very prominent and influential supporter of the administration,—as having in fact almost dictated its policy upon several most important subjects; and it would be very natural for him to receive Mr. Greeley's representations as proofs that, in spite of the assurance of the Secretary of State, the people would not be wholly averse to foreign intervention.

"Mr. Seward dwelt with very great earnestness on the necessity of supporting the President in his conduct of the war. The country ought to waive all objections to minor points, for the salvation of the country required supreme devotion to the general good. The dream of separation, he said, was idle. The South could not rest content with any boundary line that might be drawn. If it was the Potomac, they would want first Washington and then Baltimore; if the Susquehanna, they would want Philadelphia and then New York. Peace—permanent peace would be utterly impossible on such a basis. Of President Lincoln he spoke in the strongest terms of praise. With all his defects, he said, he seemed just the man for the crisis. Patient, capable of endurance, just and tolerant beyond example, he said that Providence had raised him up for this emergency as signally as he raised up Washington for the necessities of our struggle for independence.

"I forgot to mention an important incident on Sunday. At about one o'clock, I was sent for by General Burnside, who had gone back to the army, and had returned again that morning. He had been to see the President, who had declined to allow him to issue the orders in question. General Halleck was in favor of it, but the President was immovable. The country, he feared, would not stand it. He had declined to accept General Burnside's resignation, but had relieved him from command, and granted him a furlough for thirty days."

Gen. Burnside's own account of his interview with the President is as follows:

"I told him that he knew my views; that I had never sought any command, more particularly that of the army of the Potomac; that my wish was to go into civil life, after it was determined that I could no longer be of any use in the army; that I desired

no public position of any kind whatever. At the same time I said that I desired not to place myself in opposition to him in any way, or to do anything to weaken the government. I said he could now say to me, 'You may take the responsibility of issuing this order, and I will approve it;' and I would take that responsibility, if he would say that it would be sustained after it was issued, because he would have to approve of it, for I had no right to dismiss a man * * * * without his approval. In case that order [No. 8] could not be approved by him, there was my resignation, which he could accept and that would end the matter forever, so far as I was concerned; that nothing more would be said in regard to it. I told him he could be sure that my wish was to have that done which was best for the public service, and that was the only way in which I could command the army of the Potomac. The President replied to me: 'I think you are right * * * * But I must consult with some of my advisers about this;' I said to him, 'If you consult with anybody you will not do it, in my opinion.' He said, 'I cannot help that; I must consult with them.' I replied that he was the judge, and I would not question his right to do what he pleased. * * * * I returned to my command, and came up again that night * * * and the President told me he had concluded to relieve me from the command of the army of the Potomac, and place Gen. Hooker in command. I told him that I was willing to accept that as the best solution of the problem, and that neither he nor Gen. Hooker would be a happier man than I would be if Gen. Hooker gained a victory there. The President also said that he intended to relieve Gen. Sumner and Gen. Franklin. I said that I thought it would be wise to do so. Gen. Sumner was a much older officer than Gen. Hooker, and ought not to be asked to serve under him."

The following letter from Gen. Franklin is cheerfully admitted here:

HARTFORD, Conn., Jan. 5, 1880.

MR. HENRY W. RAYMOND,

Dear Sir: I read with much interest your article in SCRIBNER for January, 1880, containing extracts from the journal of your father. These extracts make the impression upon the reader, seventeen years after the journal was written, that your father believed me responsible for the Union defeat in the Battle of Fredericksburg in December, 1862. That he so believed when he wrote the journal, the journal shows. But after the matter had been investigated and reported upon by the Committee on the Conduct of the War, I published a pamphlet in vindication of my course. At the request of my friends, your father carefully examined this pamphlet, and the documents upon which its statements were founded, and came to the conclusion that the impressions which he formed from the statement of General Burnside and his friends were erroneous, and in an editorial article in the New York "Times," of March 20th, 1863, stated as follows:

"It seems to us clear, that General Franklin not only performed all the service enjoined upon him in his orders, but that he did more than was contemplated by them in pushing the attack upon the enemy in his front. It is to be presumed that the Government does not consider his conduct in that affair obnoxious to censure, or it would have given him a court of inquiry; and if this is the case, he ought to be relieved from any implied censure, and placed

in a position where the country can again have the benefit of his unquestionable ability in the prosecution of the war."

I give the extract because I have not the entire article. But it is enough to show you I think, that the "Journal" does not give your father's final judgment in my case, and that its publication at this time, without comment, or without notice that his opinions changed after he heard my side of the case, is hurtful to my reputation.

Your father was so distinguished as an editor, and as a politician, that I was particularly anxious to stand well in his opinion. That I did so stand I know. But his "Journal" conveys the reverse impression, and I write to ask you to publish in the next SCRIBNER the sense of what I have here written you, if you can properly do so.

The pamphlet to which I refer has been published in the "Rebellion Record," and I have a copy which is at your service if you wish to see it. * * * *

Respectfully yours,

W. B. FRANKLIN.

The following letter from Mr. Lincoln to General Hooker, which was first published in the Providence "Journal" of May 6th, 1879, is also of interest in this connection:

"EXECUTIVE MANSION, WASHINGTON, D. C., Jan. 26, 1863.—*Maj.-Gen. Hooker*—GENERAL: I have placed you at the head of the Army of the Potomac. Of course I have done this upon what appears to me to be sufficient reasons; and yet I think it best for you to know that there are some things in regard to which I am not quite satisfied with you. I believe you to be a brave and skillful soldier, which, of course, I like. I also believe you do not mix politics with your profession, in which you are right. You have confidence in yourself, which is a valuable, if not an indispensable, quality. You are ambitious, which, within reasonable bounds, does good rather than harm; but I think that, during General Burnside's command of the army, you have taken counsel of your ambition and thwarted him as much as you could, in which you did a great wrong to the country, and to a most meritorious and honorable brother-officer. I have heard, in such way as to believe it, of your recently saying that both the army and the Government needed a Dictator. Of course, it was not for this, but in spite of it, that I have given you the command. Only those Generals who gain successes can set up Dictators. What I now ask of you is military success, and I will risk the Dictatorship. The Government will support you to the utmost of its ability,—which is neither more nor less than it has done and will do for all commanders. I much fear that the spirit which you have aided to infuse into the army, of criticising their commander and withholding confidence from him, will now turn upon you. I shall assist you as far as I can to put it down. Neither you nor Napoleon, if he were alive again, could get any good out of an army while such a spirit prevails in it. And now, beware of rashness. Beware of rashness; but, with energy and sleepless vigilance, go forward and give us victories.

Yours, very truly,

"A. LINCOLN."

To resume the narrative of the journal:

"General Burnside said he knew my friendly feelings towards him and had no doubt I would be inclined to vindicate him from censure. But he

begged me not to do this at any possible risk to the good of the army and the country. He thought it important that the existence of his order, concerning Hooker, should never be known, as it would put Hooker in a bad light and weaken that confidence of the public in him as an officer and a man which would be absolutely essential to his success. He said he should give him the most cordial support and do everything in his power to aid him. He was a fine officer, and would unquestionably achieve a victory.

"I have been greatly impressed by General Burnside's frankness, simplicity and noble truthfulness of character. He has all the elements of a successful soldier and a popular commander. His self-distrust is too great. But if he had been left longer in command, with full power to do what he should think necessary, I am sure he would have made this army more effective than it has yet been."

General Burnside's magnanimous prophecy as to General Hooker's success was not proved true. Carrying out General Burnside's desire for a movement according to his own plan, supported by seven army corps with 120,000 men as against General Lee with 70,000 men, the Army of the Potomac crossed the river, and, after several days of severe fighting, recrossed the river again with the loss of over 11,000 men.

Here occurs another break in these memoranda, and then an "inside" account of the senatorial contest in the New York legislature when Governor Morgan was elected to the United States Senate, but which hardly seems to me to be of general interest. So I have taken the next extracts from what was written about a month after the entry of January 27th, and which gives some further facts in connection with the proposed French Intervention scheme. I may say just here that Mr. Greeley's attempt to effect this purpose of his is a matter of history, but the facts here stated concerning the embarrassment it caused the Government and the other details pertaining to it, the conversation with public men, etc., have not before been published.

"Thursday, February 12th. Yesterday I came to Washington to try to get the duty on printing paper repealed and reduced. Fletcher Harper and William Appleton were with me. Called at Mr. Seward's this evening and had a good deal of conversation with him on foreign affairs. He gave me a copy of his reply to the French proposition for commissioners of the North and South to meet on neutral ground and discuss the causes of the war. He seemed to anticipate that this letter would be popular, and suggested that by making an effort to rally the people upon it we could override the various smaller issues that are dividing the country. I told him I would telegraph to the 'Times' to back it up very strongly. He said that M. Mercier had

called upon him to make explanations about his correspondence with Greeley, and had disclaimed any attempt to intrigue with parties or individuals against the Government. Seward said that Mercier originally read Greeley's letter to Stoeckel, the Russian minister, and that when he came to the concluding paragraph, which was a protest that he could not favor any mediation which should hazard the Union, he said: 'That's all bosh, of course.' Mercier's letter to his Government, saying that Seward had consented to his going to Richmond and had authorized him to say to the authorities that we had no revengeful feelings toward the South, and would be glad to see their Senators and Members of Congress back again, has come back here and excited a good deal of attention and comment. Seward sent in to the Senate in reply to a resolution of inquiry, a letter saying that he had never given any foreign minister, nor anybody else, any authority to make representations of any sort to the rebel government. I asked Mr. Seward if there was any difference of opinion on this point between him and M. Mercier. He said no—that he had shown his letter to Mercier before he sent it to the Senate.

* * * * *
 "Friday, 13th. I went round to Mr. Seward's to breakfast—none but his family being present. Afterwards he walked over with me to the White House to see the President, who was at breakfast when we arrived, but soon came in. He seemed jaded and tired but in pretty good spirits.

* * * * *
 "After leaving the President's, I went with the other New York gentleman before the Committee of Ways and Means, to represent the necessity of reducing or suspending the paper duty. Went into the Senate, and, while there, listened to a very discreditable wrangle on party matters between Chandler, Republican, and Richardson, Democrat from Illinois, and then went to dine at Mr. Seward's, where there was quite a large party of ladies and gentlemen. General Halleck and his wife were there, with two or three third-rate foreign ministers. I had for my neighbors Senator Latham and Colonel Townsend—the latter of whom told me that Hulsemann, the Austrian Minister, told him he knew how rapid were the changes of public sentiment among the American people, and that he had no doubt the Southern people would, by and by turn suddenly *en masse* for the Union. * * * *

"Mr. Seward told me the French minister had applied to us for negroes to go as soldiers to Mexico, and, being refused, had applied to the Pacha of Egypt and got one regiment. He had caused a resolution to be introduced into the Senate making inquiry into this matter, and was about to send a reply. The application to our government being confidential, he could not mention it.

"During the day I called on Mr. Stanton, and found him in high spirits about the prospects of the war. At every point, he said, we had all the troops required for success, and he had no doubt we should speedily hear of brilliant victories. He could not understand the depression that seemed to prevail in New York. I told him several of us had been thinking of getting up a public meeting to sustain the government without regard to the minor issues which seemed to divide the people. He thought we had better await news from Charleston. I asked him if he felt confident of success in the attack. He said yes—we ought to succeed, for we had all the men there that Dupont and Foster thought necessary.

"Saturday, February 14th. Returned to New York. Heard on the way that the *Wichawken*, one of the iron-clads destined for Charleston, had broken a cylinder and was disabled. Foster had come to Washington, also, probably to apply for reinforcements. It is said the rebels have fortified Charleston very strongly, and that they are able to concentrate a very strong force there.

"Tuesday, February 17th. At the club on Monday evening I had a long conversation with Colonel Stebbins, Member-of-Congress-elect, on the prospect of French intervention. He thought it quite certain to take place, and said he had regarded it as probable for months. His opinions, he said, had been a good deal influenced by what a friend of his, a Mr. Kellogg, had told him of certain views developed by Louis Napoleon when in this country, in 1837. The course of our conversation led him to ask me to meet Mr. Kellogg and hear his own statement of the matter. I of course assented, and he said he would bring him to the club the next evening.

"I lunched with Jerome, who had brought Mr. Forbes, a wealthy China merchant, who had become familiar with prominent French publicists during a residence in Paris, and whose views on the subject might be valuable. He proved to be a very intelligent and right-minded man. He knew Drouyn de Lhuys, the present Secretary of Foreign Affairs, very well, as also Mercier, and other men of position. He said he had no doubt the Emperor would interfere forcibly to break our blockade in the Spring. He regarded Mercier as a very adroit diplomatist, * * * and thoroughly in sympathy with the secession movement from the beginning. He knew that, as long ago as October, Mercier had said the French Emperor would offer mediation, and that, if this should be rejected, the blockade would be broken by force, and that, too, before the end of March. The first part of the prediction had been fulfilled, and he had no doubt the other would be, also. The Emperor's movements in Mexico were, in Mr. Forbes' judgment, part of his general policy on this continent. He did not think his interference greatly to be deprecated. It would lead to the sacrifice of so much of our commerce as might be afloat; but in every other respect it would not be disadvantageous. He showed me a letter from Julien de la Gravière, the French admiral in the Gulf, expressing the greatest disgust at the nature of the service, saying he had asked to be relieved, and was going home by way of New York.

"In the evening, I met Mr. Kellogg with Colonel Stebbins at the club. Mr. K. is a chemist, a man of clear but slow mind, and evidently reliable. It seems that in 1857 he accidentally made the acquaintance of a Mr. Riellieux, a French gentleman of independent fortune, highly educated, familiar with the course of public affairs, and especially with everything relating to France. He had been an intimate friend of a Mr. Müller, a plain man, educated as an engineer, who had been a confidential friend and adviser of Napoleon I., and who claimed to have invented the daguerreotype long before the time of Daguerre, and to have used it for military purposes during the wars of Napoleon. He was at Waterloo, and left France for this country after the fall of the Emperor. Mr. Riellieux's relations with him were of a very confidential nature, and he had heard from him many things concerning the present Emperor of France. Among others, this: Soon after Louis Napoleon came to the United States, in 1837, he sought out Mr. Müller, whom he had known in Europe, and after placing himself on confidential relations with him, had placed in his hands three

volumes of notes and reflections on public affairs, and very largely consisting of projects that ought to be carried into effect by him when he should become emperor, for the honor and glory of France. Some of them related to the steps he should take to obtain possession of the throne, and especially of the policy he should adopt to have himself made the *second* choice of both the Republicans and Legitimists, each party being kept too weak to secure its own success; others related to the policy to be pursued in regard to the temporal power of the Pope; and all these had been substantially carried into effect. There were also voluminous speculations as to the interests of France on this continent. She must, in the first place, have colonies, and must seek them here. Mexico was designated as a country to be brought under French control, and Germany was to be appeased by offering one of her princes the Mexican throne. The power of the United States must be checked, or by the end of the century she would be too great for all the powers of Europe combined. The question of slavery could be used to divide the North and South, and when they were once engaged the opportunity would be offered for France to recover the old province of Louisiana, which Napoleon I. ought never to have alienated. France must also have actual possession or substantial control of a cotton-growing district, so that she might never be compelled to rely exclusively upon England on the one hand nor the United States on the other.

The reader will remember that Louis Napoleon was exiled from France after his abortive attempt to overthrow the government at Strasburg, in October, 1836. He went first to Brazil, and from there came to New York in January, 1837, and lived in this city for some time, in great pecuniary embarrassment. After the death of the Duke of Reichstadt, in 1832, Louis Napoleon became the heir to the French throne, according to the will of Napoleon I. He then devoted himself to literary labors, and his '*Idées Napoléoniennes*' were published in 1839. Possibly it was the MSS. of this work that Mr. Müller saw.

"These were some of the views set forth by Louis Napoleon in the MSS. perused by Müller, and the contents recited by him to Riellieux, and by him again to Kellogg. The evidence is a little remote, but even in this form the memoranda have a good deal of interest as throwing some light on the present movements of Louis Napoleon. Mr. Kellogg had made rough stenographic notes of these conversations with Mr. Riellieux at the time they occurred, and attached a good deal of importance to them as indications of the future course of events.* Müller, he said, died in Howard street in this city, two or three years since. Riellieux is still living, and has recently disposed of his property, with a view to the catastrophe, which he thinks near at hand. He is a Republican, and is very anxious that Napoleon's designs should be understood in advance, and due provision made against them. Colonel Stebbins

* The reader must remember that, while there is no doubt of the correctness of Mr. Raymond's report of this conversation, the statements here made are several removed from direct evidence, and must be taken with caution.—Ed. S. M.

thought French intervention by force very probable. He thought the effect would be to end the war by impressing our people with the hopelessness of the struggle. I thought the effect would be (1) to unite all the North, and override all the minor questions that now divide and distract the people; (2) to infuse a spirit of enthusiasm into our armies, which they could never feel when fighting their own countrymen, and thus *double* our military force, (3) to bring England to our aid, and (4) to bring the great mass of the Southern people (when they see that the purpose of Napoleon is to acquire control of their cotton districts) to overthrow their rulers and join the North. I told him I would not be at all surprised if French intervention should prove the salvation of the country. I wrote to Seward, telling him that I had heard of Mercier's saying that France would break the blockade before spring. * * *

"*Thursday, 19th.* A dull, rainy, dismal day. No news from any quarter, except a rumor from rebel sources that Banks had been repulsed from Port Hudson, which obtains no credit. Saw General Burnside as he passed through the city to Washington, having received orders to report himself there ten days before the expiration of his furlough. He said he did not know his destination.* * * [On the 26th of April General Burnside, assumed command of the Department of the Ohio.—H. W. R.] A good deal of talk in the streets about the prospects of French intervention. There is a rumor that some of the leading French merchants have been preparing for it for some weeks. Received a letter from Seward expressing incredulity about Mercier's having told Judge Pierrepont that France would break the blockade, but evincing some anxiety and wishing me to make inquiries. * * *

"*Monday, March 2.*—At the office all day. For the last few days I have been in a controversy with the 'Tribune' on their assertion that Mr. Seward had sent dispatches from the State Department in the President's name, without first submitting them for his approval. As I had conversed with Mr. Seward about this I denied it, and he confirmed the denial in a telegram which I published. The 'Tribune' mainly through a correspondent (Judge

White) persists in its statement. The root of the whole affair, I believe is this: Mr. Sumner discovered a short letter from Seward to Adams in the volume of Diplomatic Correspondence for 1862, marked 'confidential' and saying that the pro-slavery secessionists and the abolitionists seemed combined to bring about a servile insurrection. This stung Sumner, and it was said at the time that he went to the President about it and that he disavowed all knowledge of it—*Voilà tout*. Read Law on Financial History of England during wars of 1702-1815.

"*Thursday, March 5.*—At lunch to-day had a talk with Mr. Forbes. He said he had very good reasons for saying that the famous disease at the National Hotel in Washington in 1857, from which so many persons suffered, was the result of an attempt on the part of southern disunionists to poison Buchanan, in order to bring in Breckenridge as President, who was in their councils and would throw the whole power of the government into their scale. He said that soon after he visited a prominent southern politician, living at Culpepper Court House in Virginia, and that from what there transpired he was convinced he was in the plot. He did not mention his name and I did not think it proper to ask it.

"I called to see S. L. M. Barlow. Told him I should go to Washington soon. He urged me to advise the government not to make any arbitrary arrests here, because he said he knew there was an organization of some thousands of persons here anxious to raise such an issue between the general government and the local authorities, for the purpose of getting up a fight in the city of New York. He spoke very warmly and very sensibly about it. He read me a letter he wrote to Buchanan, Dec. 30, 1860, urging him to thwart the movement of southern secessionists to bring about civil war. He thought McClellan ought to resign, and said the war must be fought out. In the stock market to-day there was great excitement from the fall of gold from 170 to 156. Feeling in town is much more confident and hopeful. The arrangements for a general meeting to-morrow night, to include war men of all parties meets with general approval." * * *

VITTORIA.

Wise was the word the wise man spake who said:
 "Angelo was the only man to whom God gave
 Four souls:"—the soul of sculpture and of song,
 Of architecture and of art; these all.
 For so God lovèd him as if he were
 His only child, and grouped about his brows
 Ideals of himself,—not angels mild
 As those that flit and beckon other lives,
 But cherubim and seraphim; tall, strong,
 Unsleping, terrible; with wings across
 Their mighty feet, and eyes—if we would look
 Upon their blazing eyes, these too are hid—
 Some angels are all wings! Oh, shine and fly!
 Were ye not angels ye would strike us blind.
 And yet they did not, could not dazzle her—
 That one sweet, silent woman unto whom

He bent as pliant as the marble turned
 To life immortal in his own great hand.
 Steadfast Vittoria looked on Angelo.
 She lifted lonely eyes. The years stepped slow.
 Fourfold the reverence which he gave to her.
 Fourfold the awful tenderness, the trust,
 The loyalty, the loss. And oh, fourfold
 The comfort, beyond all power of comforting
 Whereby a lesser man may heal the hurt
 Of widowhood.

Pescara had one soul—

A little one; and it was stained. And he—
 It, too, perhaps (God knows!)—was dead.
 The dead are God's.

Vittoria had one heart.

The woman gave it, and the woman gives
 Once. Angelo was too late. And one who dared
 To shed a tear for him has dropped it here.

TWO VIEWS OF NAPOLEON.*

MEMOIRS of the highest importance, the contents of which have been awaited with eagerness, in the hope that they might throw more light on the time and character of the first Napoleon, have long been known to exist in the families of Metternich and Rémusat. The reasons given for withholding them from the public have been the same in either case and have produced the same result, namely, to whet expectancy the more. For what could arouse curiosity better than the statement that persons and prejudices had been handled so freely in these documents that it would be necessary to allow a whole generation to die out before committing them to history? Yet this was the plea on which the memoirs of Prince Metternich and Madame de Rémusat were withheld from publication and denied to those engaged in historical research. Lately they have been issued in quick succession. The first part of that of Madame de Rémusat is well spread in this country and widely commented upon; that of Prince Metternich, on the other hand, is at the present writing not yet published here, the advance sheets of the English edition having just made their appearance on this side of the Atlantic. Madame de Rémusat knew Napoleon as a domestic man; Prince Met-

ternich, as a sovereign. The one was a confidante and perhaps a friend of Josephine; the other conducted and possibly originated the marriage of Napoleon with Maria Louisa of Austria, for which purpose Josephine was divorced. While Madame de Rémusat received the outpourings of jealousy on the part of Josephine at a time when the divorce was not thought of, Prince Metternich had to bear the insolence of the European autocrat in those prearranged scenes when Napoleon sought to intimidate the Powers by browbeating their ministers. The Lady of the Palace played chess with Napoleon, talked with him, and possibly had a serious and most intellectual flirtation with him on the sly—at least naughty people charged her with it and bitterly wounded the good woman thereby—while Metternich was the evil genius of Napoleon in the days after the retreat from Moscow, and had the satisfaction not only of telling him to his face how he was lost and why he was lost, but also, subsequently, of conducting affairs to the entire discomfit of Napoleon in his retreat to Paris. One memoir therefore reinforces the other; for we have two keen intellects entirely different from each other at work under entirely different circumstances upon the problem which has proved of an interest

* Memoirs of Madame de Rémusat. 1802-1808. Edited, with a preface and notes, by her grandson, Paul de Rémusat, Senator. Part I. Translated by Mrs. Cashel Hoey and Mr. John Lillie. New York: D. Appleton & Co., and Harper & Brothers. Part II. (French edition). New York: Christern.

Memoirs of Prince Metternich. 1773-1815. Edited by Prince Richard Metternich. Translated by Mrs. Alexander Napier. Two volumes. New York: Charles Scribner's Sons.

second to none in history—the character of Napoleon Bonaparte.

It should be remembered that for the last fifty years a swarm of memoirs has been rising out of France, having for their subjects the persons of fame or notoriety in generations nearly or immediately before. Some have borne on their faces the stamp of genuineness; others have been at once rejected as palpable forgeries; a third class stands between these two, and are either forgeries of great cleverness, or else contain the truth mixed so inextricably with falsehood that the two are incapable of separation. Plainly, the memoirs of Prince Metternich belong to the first category. They are as authentic as an official document or a piece of red tape. We see the old bureaucrat pigeonholing letters and endorsing protocols with the most intense regard for the proprieties of an Embassy; every thing must be submitted in writing, and all thoughts digested in numbered categories. One might as soon doubt the genuineness of a register of births. But how is it with the memoirs of Madame de Rémusat, which her grandson, Paul de Rémusat, "Senator," has been publishing in the "Revue des deux Mondes?" Do these belong to the genuine, or the forged, or the mixed type of memoirs? It is certain that Madame de Rémusat did write a book in epistolary form which contained all the tittle-tattle of the household of Napoleon during her presence therein as Lady of the Palace. But we know that the original was burned by her in a moment of panic on the return of Napoleon from Elba. Being a serious person, according to the testimony of others as well as herself, Madame de Rémusat enjoyed scandal quite as much as those frivolous members of the household against whose ignorance she takes care that her own little lamp shall be made to shine. She had been married at sixteen to a man whose solemn air and worthy mien marked him out by nature for a French judge. Now Napoleon wanted an antidote to the free and easy manners of his generals, and the Rémusats also had other important uses. The relations of both M. and Mme. de Rémusat to the old nobility were sufficiently strong to make them appropriate instruments for the ambition of Napoleon. They were used as the entering edge of the tool. Being of the nobility, and yet not exiled, moderate people withal, who were content with small gains, Napoleon used them as an example of good-breeding to the brave but

vulgar soldiers and to their wives, who were perforce about him; he thought he saw in them stepping-stones to the disaffected nobility of higher lineage whom he hoped to lure back to France to consolidate his throne. But when that had been partially accomplished there was no more use for the Rémusats. They were forced to see new arrivals obtaining honors and rewards, when they, who had been the first to sacrifice themselves in the eyes of their noble friends and relations by taking office under the usurper, remained stationary, or even lost in favor at Court. Madame de Rémusat has left traces of this very natural but not too noble resentment:

"Yet I had my own little ambition, too, but it was moderate and easy to satisfy. The Emperor had made known to me through the Empress, and M. de Caulaincourt had repeated it to my husband, that, on the consolidation of his own fortunes, he would not forget those who had from the first devoted themselves to his service. Relying on this assurance, we felt easy with regard to our future, and took no steps to render it secure. We were wrong, for every one else was actively at work. M. de Rémusat had always kept aloof from any kind of scheming,—a defect in a man who lived at a court. Certain good qualities are absolutely a bar to advancement in the favor of sovereigns. They do not like to find generous feelings and philosophical opinions which are a mark of independence of mind in their surroundings; and they think it still less pardonable that those who serve them should have any means of escaping from their power. Bonaparte, who was exacting in the kind of service he required, quickly perceived that M. de Rémusat would serve him faithfully, and yet would not bend to all his caprices. This discovery, together with some additional circumstances which I shall relate in their proper places, induced him to discard his obligations to him. He retained my husband near him; he made use of him to suit his own convenience; but he did not confer the same honors upon him which he bestowed on many others, because he knew that no favors would procure the compliance of a man who was incapable of sacrificing self-respect to ambition. The arts of a courtier were, besides, incompatible with M. de Rémusat's tastes."

The truth seems to have been that the Rémusats took office under Napoleon with the feeling of martyrs. They knew that the men of the old *régime* would not forgive their desertion from the sacred cause. The memoirs begin with a justification of their course in making the best of actualities and declining to sulk forever in a cause which was hopeless, because no longer suitable to the age or the temper of France. Uncomfortable with the old nobility, how could they help being bitter toward the *parvenu* who used them and then failed to reward them as fully as he did others? These considerations must never be lost sight of for

one instant while reading the curious mixture of honey and gall which purports to be the actual, unadulterated memoirs of the first Lady of the Palace to Napoleon and Josephine. It may not account for all the villainous charges brought against the Bonapartes; but it will explain the animus which prevails in the book. It explains, if it do not excuse, the ingratitude which will naturally shock the reader.

In support of this criticism of Mme. de Rémusat, a singular coincidence may be adduced. Of all the members of the Bonaparte and Beauharnais families, remark that only two persons escape scot free from the charges, either simply slanderous or horrible, which Madame de Rémusat pours upon them. And who are these two? Eugène and Hortense de Beauharnais. But remark, further, that these two are the only ones who had in their veins the blood of that old French nobility to which the Rémusats belonged! Although they were servants of the usurper, the Rémusats could not eradicate their inborn contempt for the vulgar and doubtless in some cases licentious family which the Great Napoleon had placed over Europe. Yet they were forced to admire Napoleon, in spite of every thing. "I found the crown of France lying on the ground," said Napoleon, "and I took it up on the point of my sword." Also, they tell us that he claimed he was no Oliver Cromwell, but a sovereign by natural right, who had usurped no throne, but erected one where none existed. Mme. de Rémusat does justice to this claim of Napoleon, yet her instincts for the old system as against the new, enlivened by bitterness, gained the upper hand, and his whole family had to suffer along with him.

It is singular that other persons equally intimate with Napoleon should have united in suppressing the vile slanders brought here against him and every member of his family. This leads one to inquire whether Madame de Rémusat may not be guiltless of some of the worst of them; whether Paul de Rémusat may not have heightened the flavor of the book, instead of omitting, as he claims to have done, many things of doubtful morality regarding ladies of the Court. In a foot-note which casts doubt on the paternity of Napoleon III., and destroys the efforts of Madame de Rémusat to shield even Hortense de Beauharnais from the accusations which have been made against her, the editor says:

"It is unnecessary to say that on this point I pre-

serve the exact text of the Memoirs, as they were written by the hand of their author. *I have only thought it right to suppress comments of an opposite nature on certain ladies of the Court.* The reader will, perhaps, be surprised to find no mention in these portraits of the family of either Queen Caroline or Princess Pauline Bonaparte. I leave out certain matters in relation to them which have no bearing on the Emperor himself. My father particularly desired that the text of his mother's Memoirs should be scrupulously respected. It seemed to me, however, that on this point I might fairly depart from the rules of strict editing. Habits, tastes, customs become modified by time, and much that seemed natural to a clever woman in high life at that period would give scandal in our more punctilious day."

The man who professes such delicacy, and yet prints what he does print, is open to suspicion. Furthermore, we are told just how the original memoirs in letter form happened to be destroyed, and how, many years after, Madame de Rémusat set about retrieving the loss by hunting up old letters, and consulting people who knew the affairs of those days. These memoirs, therefore, are the result of the ransacking of the memory of Madame de Rémusat and her friends at a time when the name of Napoleon was held in horror in France among the people to whom she belonged, and when all the worst accusations of a venomous press in England, inflamed both by patriotism, governmental pressure, and the gall of the *émigrés*, had obtained credence in Paris. Every jackass in France as well as England had his kick at the dead lion. How could Madame de Rémusat remember the long harangues she puts into the mouth of Napoleon? In semi-barbarous times such things are possible, because semi-barbarians say things after set formulas, and repeat speeches they have heard with astonishing fidelity; but in modern times the thing is almost impossible. Chateaubriand wrote: "The memoirs of Madame de Rémusat, with whom I was acquainted, were full of exceedingly curious details of the private life of the Imperial Court. Their author burned them during the Hundred Days, but afterward rewrote them. *They are now but recollections of former recollections; the colors are faded; but Bonaparte is always clearly depicted and impartially judged.*"

Reasons for suspecting bias in Madame de Rémusat, are, then, as follows: Her evident class instincts; her disappointed hopes of wealth or other preferment; the bitterness natural to a political change-coat; the time that had elapsed between the facts and their recording the influence of the ante-Napoleonic times, when the memoirs were re-

written; her exemption of the only two members of the Bonaparte connection who were noble and French by birth from accusations of criminality. Add to this anything which Paul de Rémusat might assume to be warranted in order to re-inforce and make more piquant the work of his grandmother, and we get the present mixture—peppery, it is true, but all the more readable and vendible for that.

As one of the greatest military geniuses in history, let us see what Madame de Rémusat has to say of Napoleon the general:

“It was well worth seeing how he talked to the soldiers—how he questioned them one after the other respecting their campaigns or their wounds; taking particular interest in the men who had accompanied him to Egypt. I have heard Madame Bonaparte say that her husband was in the constant habit of poring over the list of what are called the *cadres* of the army, at night, before he slept. He would go to sleep repeating the names of the corps, and even those of some of the individuals who composed them; he kept those names in a corner of his memory, and this habit came to his aid when he wanted to recognize a soldier, and to give him the pleasure of a cheering word from his general. He spoke to the subalterns in a tone of good-fellowship, which delighted them all, as he reminded them of their common feats of arms. Afterward, when his armies became so numerous, when his battles became so deadly, he disdained to exercise this kind of fascination. Besides, death had extinguished so many remembrances, that in a few years it became difficult for him to find any great number of the companions of his early exploits; and when he addressed his soldiers before leading them into battle, it was as a perpetually renewed posterity, to which the preceding and destroyed army had bequeathed its glory. But even this sombre style of encouragement availed for a long time with a nation which believed itself to be fulfilling its destiny while sending its sons year after year to die for Bonaparte.

* * * * *

“‘Military science,’ said Bonaparte, ‘consists in calculating all the chances accurately in the first place, and then in giving accident exactly, almost mathematically, its place in one’s calculations. It is upon this point that one must not deceive one’s self, and that a decimal more or less may change all. Now, this apportioning of accident and science cannot get into any head except that of a genius, for genius must exist wherever there is a creation; and assuredly the grandest improvisation of the human mind is the gift of an existence to that which has it not. Accident, hazard, chance—whatever you choose to call it—a mystery to ordinary minds, becomes a reality to superior men. Turenne did not think about it, and so he had nothing but method. I think,’ he added, with a smile, ‘I should have beaten him. Condé had a better notion of it than Turenne, but then he gave himself up to it with impetuosity. Prince Eugene is one of those who understood it best. Henry IV. always put bravery in the place of everything; he only fought actions—he would not have come well out of a pitch battle. Catinat has been cried up chiefly from the democratic point of view; I have, for my own part, carried off a victory on the spot where he was

beaten. The philosophers have worked up his reputation after their own fancy; and that was all the easier to do, because one may say anything one likes about ordinary people who have been lifted into eminence by circumstances not of their own creating. A man, to be really great, no matter in what order of greatness, must have actually improvised a portion of his own glory—must have shown himself superior to the event which he has brought about. For instance, Cæsar acted now and then with weakness which makes me suspect the praises that are lavished on him in history.’”

Rather elaborate portraits of the chief members of the Bonaparte family form a sort of introduction to the memoirs. No part of the work contains harsher comments:

“Napoleon Bonaparte is of low stature, and rather ill-proportioned; his bust is too long, and so shortens the rest of his figure. He has thin chestnut hair, his eyes are grayish blue, and his skin, which was yellow while he was slight, became in later years a dead white without any color. His forehead, the setting of his eye, the line of his nose—all that is beautiful, and reminds one of an antique medallion. His mouth, which is thin-lipped, becomes agreeable when he laughs; the teeth are regular. His chin is short, and his jaw heavy and square. He has well-formed hands and feet; I mention them particularly, because he thought a good deal of them.

“He has an habitual slight stoop. His eyes are dull, giving to his face when in repose a melancholy and meditative expression. When he is excited with anger his looks are fierce and menacing. Laughter becomes him; it makes him look more youthful and less formidable. It is difficult not to like him when he laughs, his countenance improves so much. He was always simple in his dress, and generally wore the uniform of his own guard. He was cleanly rather from habit than from a liking for cleanliness; he bathed often, sometimes in the middle of the night, because he thought the practice good for his health. I have said there was a sort of fascination in the smile of Bonaparte; but, during all the time I was in the habit of seeing him, he rarely put forth that charm. Gravity was the foundation of his character—not the gravity of a dignified and noble manner, but that which arises from profound thought. In his youth he was a dreamer; later in life he became a moody, and later still, an habitually ill-tempered man. When I first began to know him well, he was exceedingly fond of all that induces reverie—Ossian, the twilight, melancholy music. I have seen him enraptured by the murmur of the wind; I have heard him talk with enthusiasm of the moaning of the sea; and he was tempted sometimes to believe that nocturnal apparitions were not beyond the bonds of possibility—in fact, he had a leaning to certain superstitions. When, on leaving his study in the evening, he went into Madame Bonaparte’s drawing-room, he would sometimes have the candles shaded with white gauze, desire us to keep profound silence, and amuse himself by telling or hearing ghost stories; or he would listen to soft, sweet music executed by Italian singers, accompanied only by a few instruments lightly touched. Then he would fall into a reverie which all respected, no one venturing to move or stir from his or her place. When he aroused himself from that state which seemed to

procure him a sort of repose, he was generally more serene and more communicative. He liked then to talk about the sensations he had experienced. He would explain the effect music had upon him; he always preferred that of Paesielo, because he said it was monotonous, and that impressions which repeat themselves are the only ones that take possession of us. The geometrical turn of his mind disposed him to analyze even his emotions. No man has ever meditated more deeply than Bonaparte on the 'wherefore' that rules human actions. Always aiming at something, even in the least important acts of his life, always laying bare to himself a secret motive for each of them, he could never understand that natural nonchalance which leads some persons to act without a project and without an aim. He always judged others by himself, and was often mistaken, his conclusions and the actions which ensued upon them both proving erroneous.

"Bonaparte was deficient in education and in manners; it seemed as if he must have been destined either to live in a tent where all men are equal, or upon a throne where everything is permitted. He did not know how either to enter or to leave a room; he did not know how to make a bow, how to rise, or how to sit down. His questions were abrupt, and so also was his manner of speech. Spoken by him, Italian loses all its grace and sweetness. Whatever language he speaks, it seems always to be a foreign tongue to him; he appears to force it to express his thoughts.

"In trying to depict Bonaparte, it would be necessary, following the analytical forms of which he was so fond, to separate into three very distinct parts his soul, his heart, and his mind; for no one of these ever blended completely with the others. Although very remarkable for certain intellectual qualities, no man, it must be allowed, was ever less lofty of soul. There was no generosity, no true greatness in him. I have never known him to admire, I have never known him to comprehend, a fine action. He always regarded every indication of a good feeling with suspicion; he did not value sincerity; and he did not hesitate to say that he recognized the superiority of a man by the greater or less degree of cleverness with which he used the art of lying. On the occasion of his saying this, he added, with great complacency, that when he was a child one of his uncles had predicted that he should govern the world, because he was an habitual liar. 'M. de Metternich,' he added, 'approaches to being a statesman—he lies very well.'

"All Bonaparte's methods of government were selected from among those which have a tendency to debase men. He dreaded the ties of affection; he endeavored to isolate every one; he never sold a favor without awakening a sense of uneasiness, for he held that the true way to attach the recipients to himself was by compromising them, and often even by blasting them in public opinion. He could not pardon virtue until he had succeeded in weakening its effect by ridicule. He cannot be said to have truly loved glory, for he never hesitated to prefer success to it; thus, although he was audacious in good fortune, and although he pushed it to its utmost limits, he was timid and troubled when threatened with reverses. Of generous courage he was not capable; and, indeed, on that head one would hardly venture to tell the truth so plainly as he has told it himself.

* * * * *

"I ought now to speak of Bonaparte's heart; but if it were possible to believe that a being, in every other way similar to ourselves, could exist without

that portion of our organization which makes us desire to love and to be loved, I should say that in his creation the heart was left out. Perhaps, however, the truth was that he succeeded in suppressing it completely. He was always too much engrossed by himself, to be influenced by any sentiment of affection, no matter of what kind. He almost ignored the ties of blood and the rights of nature; I do not know that even paternity weighed with him. It seemed, at least, that he did not regard it as his primary relation with his son. One day, at breakfast, when, as was often the case, Talma had been admitted to see him, the young Napoleon was brought to him. The Emperor took the child on his knee, and, far from caressing, amused himself by slapping him, though not so as to hurt him; then, turning to Talma, he said, 'Talma, tell me what I am doing?' Talma, as may be supposed, did not know what to say. 'You do not see it,' continued the Emperor; 'I am slapping a king.'

Madame de Rémusat does not seem to suspect the humor of this last anecdote, and sets down as ferocity what was manifestly sport. She charges that whenever Napoleon fell in love, he became outraged at the tyranny of the feeling, enraged with the audacious individual, "and he would abruptly get rid of the object of his passion, having let the public into the transparent secret of his success."

"The intellect of Bonaparte was most remarkable. It would be difficult, I think, to find among men a more powerful or comprehensive mind. It owed nothing to education; for, in reality, he was ignorant, reading but little, and that hurriedly. But he quickly seized upon the little he learned, and his imagination developed it so extensively that he might easily have passed for a well-educated man.

"His intellectual capacity seemed to be vast, from the number of subjects he could take in and classify without fatigue. With him one idea gave birth to a thousand, and a word would lift his conversation into elevated regions of fancy; in which exact logic did not, indeed, keep him company, but in which his intellect never failed to shine. * * * Like an actor who becomes excited by the effect he produces, Bonaparte enjoyed the admiration he watched for closely in the faces of his audience."

Josephine is stabbed more skillfully and with deadlier effect than any one else. She appears to have been the greatest benefactor to Madame de Rémusat, but, on the other hand, it must be remembered that the writer of these memoirs is said to have voluntarily shared the disgrace that befell her patroness.

"Being a friend of the beautiful Madame Tallien, she was introduced into the society of the Directory, and was especially favored by Barras. Madame de Beauharnais had very little fortune, and her taste for dress and luxury rendered her dependent on those who could help her to indulge it. Without being precisely pretty, she possessed many personal charms. Her features were delicate, her expression was sweet; her mouth was very small, and concealed her bad teeth; her complexion was rather

dark, but with the help of red and white skillfully applied she remedied that defect; her figure was perfect; her limbs were flexible and delicate; her movements were easy and elegant. La Fontaine's line could never have been more fitly applied than to her:

'Et la grâce, plus belle encore que la beauté.'

She dressed with perfect taste, enhancing the beauty of what she wore; and with these advantages and the constant care bestowed upon her attire, she contrived to avoid being eclipsed by the youth and beauty of many of the women by whom she was surrounded. To all this, as I have already said, she added extreme kindness of heart, a remarkably even temper, and great readiness to forget any wrong that had been done to her.

"She was not a person of remarkable intellect. A Creole, and frivolous, her education had been a good deal neglected; but she recognized her deficiencies, and never made blunders in conversation. She possessed true natural tact; she readily found pleasant things to say; her memory was good—a useful quality for those in high position. Unhappily, she was deficient in depth of feeling and elevation of mind. She preferred to charm her husband by her beauty rather than the influence of certain virtues. She carried complaisance to excess for his sake, and kept her hold on him by concessions which, perhaps, contributed to increase the contempt with which he habitually regarded women."

There is no question whatever that Madame de Rémusat was a woman of unusual breadth of mind and penetration. Yet the hereditary dislike of upstart nobles warped her judgment at times. We shall see the same phenomenon in Metternich. In the course of the second volume of the Rémusat memoirs, which has appeared in France, but has not yet been issued in English translation, the natural tension between Bonaparte and Beauharnais, between the usurping Italians, and the ancient French noble family is distinctly acknowledged. Buffeted by each of these parties in turn, M. and Madame de Rémusat could not fail to side eventually, if not at once, with the Beauharnais. The second volume does not add materially to our view of Napoleon, but gives additional scenes from that curious epoch and is full of anecdotes that will not be forgotten hereafter.

Thus, Madame de Rémusat says that after Austerlitz, the pretensions of the Generals of Napoleon and their wives troubled the general happiness. At Munich, Napoleon is represented in a grotesque position, feigning to make love to the Queen of Bavaria. At this period he assumed much of the ceremonial of German courts, trying to escape from the arrogance of his newly ennobled Generals by establishing the old rules of etiquette and precedence usual among the fusty little courts of Germany. To what lengths such precautions went among these

old German nobles may be seen from the following:

The Elector Maximilian, of Bavaria, made king of Bavaria by Napoleon after Austerlitz, had served in France under Louis XVI. It is related that at that time the Prince de Condé offered him his daughter, but that his father and his uncle, the elector of Zweibrücken, refused the alliance for these reasons: Maximilian, being poor, would have been forced to place some of his daughters in chartered institutions established for the use of unmarried ladies of high rank. But the *mésalliance* of Louis XIV. with Madame de Montespan had so affected the royal blood of France, that some chapters of these houses of refuge for indigent spinsters of rank would have refused to accept them! The strength and ramification of ideas founded on aristocratic distinctions could hardly have a more striking example than this. Eugène de Beauharnais married a daughter of this prince; according to Madame de Rémusat, she seems to have been all that any one could wish, whether as a princess or a wife. Napoleon conceived a warm affection for her at once, and his letters, either to her or about her, when writing to Eugène, place his own character in the most amiable light. There is no mistaking the tenderness and purity of his love for Augusta of Bavaria.

In accord with their traditions, the Rémusats do not fail to continue in the second part their criticism of the pushing spirit of the new brood of dukes. The wife of Murat had the astounding audacity to object to the precedence given to the Queen of Bavaria! M. de Rémusat writes to his wife:

The profession of war gives a certain frankness to the character—a frankness rather crude, which gives one sight of the most envious passions. Our heroes, accustomed to an open conflict with their foes, have the habit of concealing nothing. They see a battle in every opposition that comes in their way, of whatever kind it may be. It is very odd to hear them talk of anything that is not military, and then afterwards of one another, depreciating deeds of prowess, alleging that chance had given enormous advantages to every one else, tearing to shreds reputations which we spectators thought the firmest established, and, as regards us civilians, so puffed up with their own glory, which is still quite warm, that one needs to sacrifice a good deal of vanity, and of vanity not without a foundation, in order to procure the honor of being supported by them at all.

Yet occasionally the generals were not without the revenge of wit, as may be perceived from the following anecdote of General Junot, which the memoir writer is frank enough to give. One day there was talk

before him of the prejudices of the ancient nobility of France. "Well," said Junot, "I don't see how it is that those fellows are so jealous of our elevation in rank. The only difference that exists between them and me is, that, for their part, they are descendants, while, for my part, I am an *ancestor*!"

Let us say it outright, Mme. de Rémusat confesses, at that time (1804-5-6), "every class of society wanted to have a share in the new creations of honor, rank, or profit, and I had to see many persons who, though they had blamed me for having joined that Court, in obedience to the calls of an old friendship, left no stone unturned to establish themselves in the same Court, out of pure personal ambition." Her description of the return of the *émigrés* to the new Court needs but little imagination on the part of the reader to make it a brilliant piece of satire.

"Something that I remarked at that time (1805-6) and which gave one plenty of amusement, was that according as the *grand seigneurs* of the old time came back to court, they all—no matter of what character they happened to be—felt a small disappointment, curious enough to contemplate. When they appeared for the first time, they found themselves again surrounded by some of the habits of their youth; they drew in once more the air of palaces, saw again the Court distinctions and orders, the galleries and throne-room, took up again the phrases used in the royal abodes, easily yielded to illusions, and thought they could bring back with them the style which had been successful in these very palaces, where nothing but the sovereign had been changed. But very soon a severe word, a will that was crushing and raw, gave them to understand, suddenly and harshly, that in that Court, unique in the world, everything had been made over again. Then it was a sight to see them, embarrassed and constrained in their futile manners, as they felt the very soil move under foot. They lost all countenance, in spite of every effort. Forced out of their own style of life, either too vain or too feeble to exchange it for a gravity of manner which did not belong to the customs of long before, they were at a loss what to say or do. Near Bonaparte the profession of courtier was *nil*. As it resulted in nothing, so it had no value; moreover there was a risk in remaining in his presence a *man*."

The portrait of old Madame d' Houdetot, heroine of the confessions of J. J. Rousseau, whom Madame de Rémusat met, forms a still more sympathetic and striking reminiscence of the old days. She belonged to a generation even earlier than the greater part of the *émigrés* whom we meet here, and preserved better than any one else the gay spirits and love of pleasure, coupled with a hatred of ugly things or ugly speeches, that come down to us like the perfume of that Court, the fragile blossom of France previous to the Revolution.

Few memoirs approach those of Madame de Rémusat in varied interest, because it seldom happens that one person has masculine tastes and diplomatic aptitudes joined to the more agreeable traits of a lady. And so, if great allowances be made for the circumstances under which these memoirs were written, they become very valuable material for the determination of the character of one of the greatest figures in all modern history. Still, the feeling that a superior sort of lackey is criticising her employers cannot be got rid of, and there is proof that Madame de Rémusat felt that such would be the case.

We are told that she wrote, on the 8th of October, 1818:

"There is a thought that sometimes troubles me. I say to myself, 'Suppose some day my son publishes this, what will be said of me?' Then the fear seizes me that I shall be held to have been malicious, or at least ill-natured, and I rack my brain for something to praise. But this man (Bonaparte) was such a ruthless destroyer of all worth, and we were brought so low, that I am straitened by the demands of truth, and I grow quite disheartened."

By one of the previous quotations from Madame de Rémusat, we have seen what Napoleon thought of Metternich: "M. de Metternich approaches to being a statesman—he lies very well." But Metternich was too clever to lie unnecessarily, especially to lie in a memoir which would have to stand the searching criticism of historians. It is true that he colors facts to his own advantage and to the credit of Austria, and omits here, and palliates there; but he does not calumniate. We feel that everything here is genuine Metternich. Let us see, then, what he says on the point where the charges of Madame de Rémusat are most malignant. "Neither of his wives," he says, in the documentary "Portrait of Napoleon"—

"Neither of his wives had ever anything to complain of from Napoleon's personal manners. Although the fact is well known already, a saying of the Archduchess Marie Louise will put it in a new light. 'I am sure,' she said to me, some time after her marriage, 'that they think a great deal about me in Vienna, and that the general opinion is that I live a life of daily suffering. So true it is that truth is often not probable. I have no fear of Napoleon, but I begin to think that he is afraid of me.'"

Metternich was a far more pitiless judge of Napoleon than the Lady of the Palace under Josephine. The latter had a higher opinion of his genius, and claims to have been a great admirer of his before her eyes were opened to his true character. Yet Metternich writes:

"A good son and a good kinsman, with those little peculiarities that are met with more particularly in the family interiors of the Italian *bourgeoisie*, he allowed the extravagant courses of some of his relations without using sufficient strength of will to stop them, even when it would have been clearly to his interest to do so. His sisters, in particular, got from him everything that they wanted."

Metternich has no hint of the gross crimes charged against Napoleon in the Rémusat memoirs, and in his review of the whole family alludes only to the "depravity" of Jerome.

Yet, in a thousand other ways, he does corroborate the picture of Napoleon drawn by her whose thanklessness for past favors shows the truth of the line: "How sharper than a serpent's tooth."

"Simple and even easy as he was in private life, he showed himself to little advantage in the great world. It is difficult to imagine anything more awkward than Napoleon's manner in a drawing-room. The pains which he took to correct the faults of his nature and education only served to make his deficiencies more evident. I am satisfied that he would have made great sacrifices to add to his height and give dignity to his appearance, which became more common in proportion as his *embonpoint* increased. He walked by preference on tip-toe. His costumes were studied to form a contrast by comparison with the circle which surrounded him, either by their extreme simplicity or by their extreme magnificence. It is certain that he made Talma come to teach him particular attitudes.

* * * * *

"Out of his mouth there never came one graceful or even a well-turned speech to a woman, although the effort to make one was often expressed on his face and in the sound of his voice. He spoke to ladies only of their dress, of which he declared himself a severe judge, or perhaps of the number of their children, and one of his usual questions was if they had nursed their children themselves, a question which he commonly made in terms seldom used in good society. He sometimes tried to inflict upon them questions on the private relations of society, which gave to his conversations more the character of misplaced admonitions than of polite drawing-room conversations. This want of *savoir-vivre* more than once exposed him to repartees which he was not able to return. His feeling against women who mixed in politics or affairs almost amounted to hatred."

Metternich, even more than Madame de Rémusat, belonged to the old style; he was more firmly a Legitimist and aristocrat by temperament, as well as birth and education. Napoleon could not fail, therefore, to impress him with his want of good breeding. Let us see his first impression of the great commander, statesman and politician:

"The judgment is often influenced by first impressions. I had never seen Napoleon till the audience which he gave me at St. Cloud, when I delivered my credentials. I found him standing in the middle of one of the rooms, with the Minister for Foreign

Affairs and six other members of the Court. He wore the Guards' uniform, and had his hat on his head. This latter circumstance, improper in any case, for the audience was not a public one, struck me as misplaced pretension, showing the *parvenu*; I even hesitated for a moment whether I, too, should not cover. However, I delivered a short speech, the concise and exact style of which differed essentially from that which had come into use in the new court of France.

"His attitude seemed to me to show constraint and even embarrassment. His short, broad figure, negligent dress, and marked endeavor to make an imposing effect, combined to weaken in me the feeling of grandeur naturally attached to the idea of a man before whom the world trembled.

"In my relations with Napoleon—relations which from the beginning I endeavored to make frequent and confidential—what at first struck me most was the remarkable perspicuity and grand simplicity of his mind and its processes. Conversation with him always had a charm for me difficult to define. Seizing the essential point of subjects, stripping them of useless accessories, developing his thought and never ceasing to elaborate it till he had made it perfectly clear and conclusive, always finding the fitting word for the thing, or inventing one where the usage of the language had not created it, his conversation was ever full of interest. He did not converse, he talked; by the wealth of his ideas and the facility of his elocution, he was able to lead the conversation, and one of his habitual expressions was, 'I see what you want; you wish to come to such or such a point; well, let us go straight to it.' Yet he did not fail to listen to the remarks and objections which were addressed to him; he accepted them, questioned them, or opposed them, without losing the tone or overstepping the bounds of a business discussion; and I have never felt the least difficulty in saying to him what I believed to be the truth, even when it was not likely to please him."

Against the utter cold-bloodedness and selfishness charged upon Napoleon by Madame de Rémusat one may set off the well-known indulgence with which he treated his family. Madame de Rémusat records this, but does not draw any favorable inference. Napoleon, his Austrian biographer writes, knew all the individual peculiarities of his family, and did not conceal from himself that he had been much to blame in giving way to the love of power and insatiable covetousness of some of them.

"He said to me one day in 1810, on the occasion of a long conversation in which he had just given me the history of his life, 'I have clouded and obstructed my career by placing my relations on thrones. We learn as we go, and I now see that the fundamental principle of ancient monarchies, of keeping the princes of the reigning house in constant and real dependence on the throne is wise and necessary. My relations have done me more harm than I have done them good; and if I had to begin again, my brothers and sisters should have nothing more than a palace in Paris and a few millions to spend in idleness.'"

Madame de Rémusat had been greatly impressed with the positive side of the mind

of Napoleon. Perhaps his frequent allusion to mathematics and disdain of "dreamers" and *idéologues* contributed to that idea. But Metternich had small opinion of Napoleon in that respect. "He had little scientific knowledge," we learn, and immediately are told—"although his partisans encouraged the belief that he was a profound mathematician." His knowledge of mathematical science would not have raised him above the level of any officer destined, as he was himself, for the Artillery; but his natural abilities supplied the want of knowledge. He became a legislator and administrator as he became a great soldier, by following his own instinct. The turn of his mind always led him toward the positive; he disliked vague ideas and hated equally the dreams of the visionaries and the abstractions of idealists and treated as mere nonsense everything that was not clearly and practically presented to him. He valued only those sciences which can be controlled and verified by the senses or which rest on observation and experience. Was Napoleon a good or bad man? "It has always seemed to me," answers Metternich, "that these epithets as they are generally understood are not applicable to a character such as his. Constantly occupied with one sole object, given up day and night to the task of holding the helm of an empire which by progressive encroachments had finished by including the interests of a great part of Europe, he never recoiled from fear of the wounds he might cause, nor even from the immense amount of individual suffering inseparable from the execution of his projects. As a war chariot crushes everything which it meets on its way, Napoleon thought of nothing but to advance. He took no notice of those who had not been on their guard; he was sometimes tempted to accuse them of stupidity. Unmoved by anything which was out of his path, he did not concern himself with it for good or evil. He could sympathize with family troubles; he was indifferent to political calamities." He had two aspects. As a private man, he was easy tempered and tractable, without being either good or bad. In his public capacity he admitted no sentiment; he was never influenced either by affection or by hatred. Did Napoleon in fact deserve to be called a great man? This is a sweeping question, to attempt to answer which shows the defect of Metternich's understanding. Characteristically does Metternich belittle Napoleon in his answer.

"It would be impossible to dispute the great qualities of one who, rising from obscurity, has become in a few years the strongest and most powerful of his contemporaries. But strength, power and superiority are more or less relative terms. If the era of the Revolution was, as its admirers think, the most brilliant, the most glorious epoch of modern history, Napoleon, who has been able to take the first place in it, and to keep it for fifteen years, was, certainly, one of the greatest men who have ever appeared. If, on the contrary, he has only had to move like a meteor above the mists of a general dissolution; if he has found nothing around him but the *débris* of a social condition ruined by the excess of false civilization; if he has only had to combat a resistance weakened by universal lassitude, feeble rivalries, ignoble passions, in fact, adversaries everywhere disunited and paralyzed by their disagreements, the splendor of his success diminishes with the facility with which he obtained it. *Now as in our opinion this was really the state of things, we are in no danger of exaggerating the idea of Napoleon's grandeur, though acknowledging that there was something extraordinary and imposing in his career.*"

Metternich was a conservative man, always sure to be found on middle ground, ready to propose compromises and adjudications. He had his vanities and his prejudices of red tape. Such a keen, sly observer could not fail to penetrate the armor of an impulsive genius like that of Napoleon; but he could hardly be expected to feel the greatnesses so forcibly as the pettinesses of his opponent. Metternich was himself petty. He snarls at Talleyrand and belittles Von Stein, either of whom might easily lay claim to a higher niche in the gallery of European statesmen than his own. His continual and pretentious claims to be truthful cannot be read without a smile, particularly after the above anecdote, given by Madame de Rémusat, has re-inforced once more the general opinion of the world as to his mendaciousness. We hear far too much of himself, of his love of truth, his modesty, his motives. One might suppose this saintly diplomatist the only truly pure and veracious public man in Europe. The picture is too highly flavored; we recognize Reynard the Fox exculpating himself before that court in which posterity plays the part of Noble the Lion. A theorist and believer in forms and ceremonies, he was shocked—not so much as some of his colleagues, but still shocked—by the brusqueness and practicality of Napoleon. Early in his career he describes certain republican deputies sent by France to the Congress of Rastadt in terms that show both his horror of rough and plain people and his diplomatic prejudices. Thus in one of his private letters dated Rastadt, Dec. 9, 1797, he says:

"This is the second time I have been going to dine with the French deputies, and at the last moment they have sent excuses to M. de Cobenzl. I declare that in all my life I never saw such ill-conditioned animals. They see no one, are sealed up in their apartments, and are more savage than white bears. Good God! how this nation is changed! To extreme neatness, and that elegance which one could hardly imitate, has succeeded the greatest slovenliness; the most perfect amiability is replaced by a dull, sinister air, which I can only fully describe by calling it Revolutionary! * * * All these fellows have coarse, muddy shoes, great, blue pantaloons, a vest of blue or of all colors, peasants' handkerchiefs, either silk or cotton, round the neck, their hair long, black and dirty, and the hideous head crowned by an enormous hat with a great red feather. One would die of fright, I believe, if one met the best clothed of them in a wood. They have a sullen air, and seem more discontented with themselves than with anyone else."

This is an admirable picture to offset that of Goethe when describing the grace and neatness of the *émigrés* with the German army during the unfortunate campaign into France in 1792. The antithesis between the old and the new *régime* could hardly be more strongly marked. And here it may be said that the pleasantest and freshest part of these memoirs will be found in the copious extracts from Metternich's private papers. He is no longer categorical, he throws off the bands of red tape, he ceases to be *poseur*. Instead of artful explanations which are intended to enhance in the eyes of posterity Metternich, his emperor, and Austria, we get rapid but excellent sketches of men and scenes. Metternich was oppressed with a feeling that he was making history, and therefore in his memoirs fabricates history more or less truthfully. But in his letters, so far as they go, he was really making history when least aware of the fact.

It is curious to find from the testimony of this diplomat behind the scenes that the latest policy regarding Europe attributed to the fertile brain of Bismarck is much the same as that of Napoleon. This is particularly the case as regards Austria and Russia. Napoleon was ever urging on Austria the advantages she would gain by taking land to the southward in return for losses to the northward. Germany was to be aggrandized at the expense of Russia and Austria; Russia to be thrown back on Asia and Austria to become a Slav power (though Slav was a word not generally used at that time) with her outlets on the Mediterranean. The relation of Metternich to the allied armies in their occupation of France in 1814 has also a strong and natural analogy to that of Bismarck in the late war. Both ac-

companied the armies and both got the credit of having done as much as the military to bring about a successful issue.

The memoirs of two persons who had close relations with Napoleon, during the most active part of his career, are of necessity deeply interesting, yet it is doubtful whether they will do much to influence the verdict already passed upon him by recent historians. Thiers, who looked upon Napoleon as a greater commander than Julius Cæsar, and second only to that Carthaginian of whom he wrote: "We seek in vain for a flaw in the character of Hannibal"—Thiers may take a rose-colored view of the man whom both Metternich and Madame de Rémusat underrate from their very different stand-points. But the same cannot be said of Lanfrey. He is unsparing in reprobation of Napoleon's conduct, especially in the later years of the Empire, when, as Thiers acknowledges, he showed on the field of battle the ruthlessness inherited from the Reign of Terror. Lanfrey's estimate of Napoleon comes much nearer that of Metternich. In his early volumes, Lanfrey takes a loftier view of the character of the man, but in the later he seems to write as if exasperated by the weaknesses and crimes of his subject. He depicts him when young, as gloomy, morose, uniting the subtlety of the Italian with the rugged self-will of the Corsican. Yet the result of reading Lanfrey's history is to increase one's respect for the genius, if not one's love for the personality, of Napoleon. Metternich, on the other hand, is neither indignant nor enthusiastic. He appears willing to say all the bad he knows, and to insinuate anything else which may belittle that hereditary foe of his country to whom his country truckled in a way far from noble. He glides diplomatically over the arrangements for the marriage of Maria Louisa and Napoleon. He relates with child-like ingenuousness the claim of the Pope that he was deceived by Napoleon and certain French prelates, and consented to the divorce of Josephine because misinformed as to the nature of the first marriage. All this is to be expected of a Metternich, but when one compares the worst that he has to say against Napoleon with charges that appear in the Rémusat memoirs, one feels that while neither document can be accepted without strong precautions against prejudice, that of the Rémusats has gained its superior piquancy by the exercise of low motives, perhaps even by the employment of the basest means.

PETER THE GREAT. II.*

BY EUGENE SCHUYLER.



A COSSACK CONQUEROR. (DRAWN BY CHARLEMAGNE, PRESENT COURT-PAINTER OF RUSSIA.)

CHAPTER VII.

THE PEOPLE AND THE GOVERNMENT.

SO MUCH for court intrigues. Struggles between courtiers for place and influence have always been carried on, and always will be carried on, and are often not devoid of political and historical importance. Court intrigues are, however, not everything. In cases where court intrigue seems to have shaped the destiny of a nation, there will usually be found some causes of popular discontent,—some struggle in the mass of the nation, which either takes advantage of the intrigue of courtiers to make itself felt, or by means of which courtiers succeed in their ends. So it was here. Whatever might be the mutual feelings of the rival families and of the rival place-holders who surrounded Theodore, they are only of importance on account of the popular fermentation which they assisted in bringing to light.

We must recall for a moment some of the peculiarities of the history of Russia.

A broad open plain with scarcely a hill, but everywhere intersected by navigable rivers, with its three zones of arid, saline steppe, of rich and fertile arable land, of forest and frozen moor, fitted in every respect to be the home of a united and homogeneous people, we find Russia a thousand years ago sparsely inhabited by disunited Slavonic tribes, frequently at war with each other and unable to cope with their neighbors of Finnish and Turkish race. Scandinavian heroes, as the legend runs, are called in; civilization and strong government go rapidly hand in hand; and a distinctively Russian Nation is born from the two centers of Nóvgorod and Kief. Christianity is introduced from Constantinople, and with it Byzantine ideas of law and polity which have never disappeared, and of which the influence is still felt. Then comes the appanage period, when the whole of Russia is divided into independent yet related



ST. VLADIMIR, SOVEREIGN OF RUSSIA, A. D. 981, WHO ESTABLISHED CHRISTIANITY IN RUSSIA. (FROM A DRAWING IN THE IMPERIAL ACADEMY OF ST. PETERSBURG.)

states, each governed by its Prince of the House of Rurik under the general headship of the oldest member of the family, the power passing not from father to son, but as now in Turkey and the East, to the oldest male member of the family.

The absolute power of the princes was, in some measure, controlled by the popular assemblies which existed in most of the larger towns. Pskof and Nówgorod had already been greatly developed, and Russia seemed to have entered early that path of progress which would in time have rendered her a free and constitutional country. Trade, especially with the west of Europe, through Nówgorod and the Hanse towns, had received a great impetus, and the court of Kief displayed a high civilization, when the whole country, overrun by the Mongols and the Tartars, was obliged to submit to their yoke. The effect of the Mongol supremacy was not felt in mixture of race and very little in corruption of language, but chiefly in the arrest of all political and commercial development, and in the introduction among the Grand Dukes of new maxims and methods of government. The Russian states were not ruled directly by the Mongols: they were merely vassal. The Grand Dukes received their confirmation from Tartary, and the only Tartar offi-

cial in Russia were those who resided in the larger towns for the collection of tribute. The greatest positive effect produced by the Tartar supremacy was the gradual union of the whole country under the Grand Dukes of Moscow and the establishment of autocracy, which was indeed necessary to this union and to the expulsion of the Tartars. One state after another was swallowed up by the Grand Duchy of Moscow, and even the free cities of Nówgorod and Pskof were mulcted of their privileges and received the tyrant. After the autocracy had justified its existence by unifying the country and freeing it from the Mongol yoke, it reached its highest development under Iván the Terrible, who succeeded for a time in entirely breaking up the power of the aristocracy or boyárs and in realizing what has so often seemed the ideal of the Russian state—an equal people under an absolute monarch. The Russian people had suffered so much from their lords, the landed proprietors, the officials, and nearly almost the whole of the noble classes, that they had become convinced—as ignorant peasants are apt to be—that it was only the nobility and the boyárs who “darkened the counsels of the Tsar” and prevented their happiness. For this reason Iván the Terrible, in spite of his cruelties, was very popular among

the masses of the Russian people, and even now his name is mentioned rather with affection than hatred. The death of Iván the Terrible, who left only feeble and minor children, gave a blow to autocracy and brought back the nobility into power.

The firm hand of Borís Godunóf, the usurper, for a time kept order, and accomplished what the nobility then thought absolutely necessary to this existence as a powerful class—*i. e.*, reduced nearly the whole of the Russian people to serfdom, an institution then first legally established. Then came the Troublous Time—that period of commotion, distress and invasion, when pretender vied with pretender, and the son of the King of Poland was crowned Tsar of Moscow. The strength of each of these pretenders was the measure of the hatred which the common people bore to the nobility. That mysterious prince, who bears in history the name of “the false Dimitri,” in spite of his foreign ways, was popular among the people, though the old nobility stood aloof from him. He was overthrown,

of the country, which had not been consulted in the matter, was against him. Finally the Poles were turned out, and, at the Diet or general assembly, in which all classes and all districts in the country were pretty fairly represented, the young Michael Románof was elected Tsar.

The whole reign of Michael was a struggle to rid the country of the Poles and the Swedes, who were attacking it from without, and to put down the bands of robbers and marauders who were making disturbance within; for the Troublous Time had left a great legacy of difficulty to the new ruler. The country was poor; every one needed money, and no one more than the Tsar himself; for officials and soldiers were loudly clamoring for arrears of pay, and for indemnity for the losses they had sustained during the wars. In order to raise money, and in order more firmly to establish the power of the Tsar, it was found necessary to have frequent recourse to the States-General, especially during the early part of the reign. Legislation was directed in part to provid-



INTRODUCTION OF CHRISTIANITY INTO RUSSIA. (DRAWN BY CHARLEMAGNE.)

not by the force of popular commotion, but by the plotting of the nobles. Basil Shúisky, who was placed on the throne by the voice of the nobles, was unable to maintain himself there, because the general sentiment

ing for the administration of the government, but chiefly to settling the difficulties caused by peasants running away from the estates of their lords during the Troublous Time. As years went on and Michael became more



RUSSIAN IRREGULAR CAVALRY. 16TH CENTURY. PAINTING BY SCHWARTZ.

firmly seated on his throne, recourse was less often had to the States-General, and the aristocracy to some extent regained its power. In the latter years of Michael's reign the government was practically carried on by a single noble, the prime minister, or Favorite, or, as the Russians of that time expressively styled him, "the man of the hour." Under the Tsar Alexis, the autocratic power again declined. Although the Tsar was absolute, and but one great meeting of the States-General was called during his reign, yet the power was exercised, not by the Tsar, but in succession by three boyárs, —Morózof, Ordín-Nastchókin, and Matvéief. The single meeting of the States-General was to decide the question of the retention of the fortress of Azof, which had been captured by the Cossacks of the Don, on their own responsibility. To retain it implied war with Turkey, with which power the Russians had always been in peace and in better relations than any other country. The Tsar and the boyárs could not decide on the retention of Azof, much as they wished it, for the simple reason that the treasury was empty. The delegates of each class in the States-General made such strong representations as to the poverty of the country that the idea of war was abandoned and Azof was restored to the Turks. As a

compensation for his loss of real power, the Tsar insisted strongly on the length and fullness of his title. An accidental omission of a single word or letter from this long and cumbrous official title—which was frequently repeated several times in the course of a document—was considered as an act of personal disrespect to the prince, almost equal to high treason, and was punished far more severely than many heinous crimes.* Then began, too, an endless dispute with

* The shortest title of the Tsar that could possibly be used, and which it was necessary to repeat every time that the Tsar's name was used in a document, petition, or discourse, was: "The Great Lord, Tsar, and Grand Duke Alexis Michailovitch, of all Great and Little and White Russia, Autocrat." The complete title, as amplified in 1667, was: "By the grace of God, Great Lord, Tsar, and Grand Duke Alexis Michailovitch, of all Great and Little and White Russia, Autocrat; of Moscow, Kief, Vladimir, Nóvgorod; Tsar of Kazan, Tsar of Astrakhan, Tsar of Siberia, Lord of Pskof and Grand Duke of Lithuania, Smolensk, Tver, Volynia, Podolia, Yugoria, Perm, Viatka, Bulgaria, and others; Lord and Grand Duke of Nóvgorod of the Lower Land of Tchernigof, Riazan, Polotsk, Rostof, Yaroslav, Bielo-ozero, Udoria, Obdoria, Condinia, Vitebsk, Mstislav, and of all the northern region; ruler and Lord of the Iverian Land, of the Kartalinian and Georgian Tsars, and of the Kabardinian Land, of the Circassian and Mountaineer Princes, and of many other realms and lands, Eastern, Western, and Northern, Hereditary Possessor, Successor, Lord and Ruler."

the representatives of foreign countries, either in Moscow or when Russian missions were received at foreign courts, on the proper recognition of the Tsar's title, on the exact words to be employed therein, and on the most accurate translation, together with complaints of diminution of title. An excuse was found for a war with Poland in "diminution" and errors in the Tsar's title in papers signed by Polish officials.

The Tsar Alexis was a man of good impulses, and of such gentle and amiable character that he was called by his subjects "The Most Debonair." But his very good qualities rendered him one of the worst sovereigns of Russia. Under the rule of the boyárs everything seemed to go from bad to worse. The country was impoverished and in places almost depopulated; the administration was defective and disorganized, and the officials were corrupt. Taxes were high and exactions frequent. A sedition broke out among the distressed people at Moscow; the Judge Plestchéief and the Okólnitchi Trakhanióty had to be given up by the Tsar to the furious populace, and were judged and executed by the mob. Morózof, the Prime Minister and brother-in-law of the Tsar, only saved his life by a timely flight. In Nóvgorod and Pskof the populace made themselves

masters of the city, and were only put down when troops arrived and laid regular siege to those places. In the south-east of Russia, Sténko Rázin, a Cossack of the Don, captured Astrakhan, and established himself on the lower Volga, whence he ravaged the whole of South-eastern Russia. The nobles and boyárs were killed, but the peasantry willingly ranged themselves under his banners, and Moscow was in imminent danger. Sténko Rásin was put down, captured and executed, but his name was always a watchword and lives till now in popular songs. He was a popular hero, embodying the discontent of the common people rather than a brigand chief,—a Russian Robin Hood.

Even after the accession of Theodore, Baron van Keller, the well-informed Dutch Resident, in writing to his government, expresses the fear that the Turkish and Tartar troubles may bring about internal disturbances, and that the common folk, who are here very hardly treated like slaves, will rise against their masters, and get their freedom by force as in the time of Sténko Rázin. And again three months before Theodore's death he writes that disturbances are feared on account of the general discontent.

Most serious, however, in its ultimate consequences, was the rise of Dissent in the



IVAN THE TERRIBLE IN OLD AGE.

Russian Church. Actuated by a spirit of reform which was in itself laudable, the Patriarch Nikon undertook the correction of all the printed and manuscript copies of the liturgy. Careful comparisons were made with the formularies and service books of the Eastern church as accepted at Constantinople, and with the early copies existing in the libraries of the Russian Monasteries; and, finally, by a decree of an Ecclesiastical Council, the corrected books were ordered to be the only ones used and the destruction was commanded of all others. This measure excited the greatest hostility on the part of some of the

nounced "Isus" or "Yisus"; whether, in a certain portion of the morning service the word "hallelujah" should be repeated twice or three times; and whether the sign of the cross should be made with the two fore fingers extended, or with the two fore fingers and the thumb conjoined as denoting the Trinity. But it will not seem so strange when we consider the Evangelical clergy of the Church of England in their fierce and violent hatred to the "Eastward position," or to preaching in a surplice instead of a black gown. However fallacious or erroneous the doctrines or ceremonies may have been, the Russian people held to



ARMED RUSSIAN ON HORSE. 16TH CENTURY.

ignorant clergy as well as of those who were heretical, but who had concealed their heresy under the incorrectness of the books which they used. Still more strong was the feeling among the mass of the people, especially in remote districts, who had a sincere, even if sometimes a superstitious, attachment to the forms and ceremonies to which they and their fathers had been accustomed. It seems certainly a matter of surprise that passions should be so excited and people be found willing to suffer martyrdom for such puerile questions as to whether the name of Jesus should be pro-

them, and the attempt at reform caused an explosion in the form of religious rebellion of popular wrath and discontent which had long been simmering. The dissenters were as far as possible put down, not only by spiritual persuasion but by the force of arms, and some of the most obstinate were executed; but the monastery of Solovétsk in the White Sea, where the ignorant monks had succeeded in winning over the Streltsi and other soldiers settled there for the protection of the place,—for it was also a frontier fortress,—held out for eight years against all the forces which the Court of Moscow could

send; and in the East of Russia, on the confines of Siberia, the inhabitants of whole villages shut themselves up in their houses and burnt themselves to death rather than accept a new and, as they considered it, a



ARM-PIECE AND SHIELD IN ONE PIECE. MIDDLE 17TH CENTURY.

diabolical religion. The Government had at last an apparent victory, and the revised service books were introduced into the churches; but in obscure convents and distant villages the "Old Believers," as they called themselves, still flourished. At the present day nearly one-half of Russia belongs in spirit if not openly to the dissenters,



RUSSIAN IRREGULAR CAVALRY. ARMOR OF WADDED CLOTH. 14TH TO 17TH CENTURY.

and the reconciliation, which is not yet complete, between the dissenters and the official church has been only accomplished by relaxing the rigor of the laws of persecution.

CHAPTER VIII.

ABOLITION OF PRECEDENCE. GRIEVANCES OF THE NATIONAL GUARD. RETURN OF MATVÉIEF.

THE need of reform was felt everywhere—in the church, in civil life, in education, in the administration, especially of justice and of the finances, and more than anywhere else, in the army. The defects of the army had caused the defeat of Russia, both by Swedes and Poles, and the Tsar Alexis readily accepted officers, men, and arms from abroad. Russia was beginning a period of transition, and a period of transition is always a period of discontent. She had arrived at that state when all thinking men saw very plainly that the old order of



HELMETS OF WADDED CLOTH. 14TH TO SECOND HALF OF 17TH CENTURY.

things had been outlived and must soon come to an end. With new ideas new systems must be introduced from Western Europe, and no one knew exactly how changes would take place, or how far they would go. Feeble as the Tsar Theodore was physically, he entered fully into the reformatory spirit, and his short reign was distinguished by many sincere efforts to improve the condition of his country. He wished to re-organize the army and he had a design of establishing an academy in Moscow for the better education of the people, and for the support of the church. He also formed a project which seemed far in advance of the times, for completely separating the military and civil offices. His early death left many of his plans inchoate, but one great reform he was able to carry

out, namely, the abolition of *precedence*, which had long been a curse, and had greatly retarded the proper administration of public affairs. According to this system of precedence, every noble kept strict account of all services which he or his ancestors had rendered to the state, and of the positions and offices which they had held. He felt he could not take a position less distinguished than any of those which his

not count in the books of precedence. This method of avoiding the custom, had come into vogue as early as the time of Iván the Terrible, and during the reigns of Michael and Alexis nearly all the campaigns had been carried on "without precedence." This of course led people to think that the Tsar might sometime issue a ukase entirely abolishing precedence, and accustomed the minds of the nobility to the



TSAR THEODORE (BROTHER OF PETER) BURNING THE BOOKS OF PRECEDENCE.

ancestors had previously occupied,—that he could not hold a subordinate office, or take a lower place at the table, or in the Council House, without derogating from his rank, or lowering and dishonoring himself and his family, in his own estimation and that of others. For this reason it was almost impossible to put capable men into a position which the public welfare required them to fill, because incapable men of nominally higher social rank refused to serve under them. So detrimental was this system,—which by the practice of so many years had become an inveterate custom,—that the loss of several campaigns, growing entirely out of struggle for place, compelled the Tsar sometimes to declare, at the beginning of a war, that it would be conducted "without precedence," that is, that the offices and positions held during the campaign should

possibility of such a reform. The campaign against the Turks in 1681, in spite of the great numbers of men under arms, and the large sums expended, had not resulted as had been wished. The Tsar Theodore therefore appointed a commission, presided over by Prince Basil Galitsyn, to consider the subject of the re-organization of the army on the western basis. The commission made a report on that subject, and as a preliminary to the system which they wished to introduce, proposed the total abolition of precedence. On the 22nd of January, 1682, Theodore called a special council of the boyárs to which he invited the Patriarch, the archbishops, and delegates from the chief monasteries. At this council the Tsar urged, as an absolute necessity for the welfare of the state, the abolition of precedence, stating, in the language of that



THE STRELTSI OF 1613.

time, that "precedence was an institution invented by the devil, for the purpose of destroying Christian love, and of increasing the hatred of brother to brother;" and he called attention to the efforts of his father, as well as of himself, for the suppression of this custom, and put the question to the assembly whether the petition of this commission should be accepted, and whether, in future, all ranks and offices should be without precedence, or, as hitherto, with precedence. The Patriarch, in the name of the archbishops and of the church, followed with a violent attack on the system of precedence, and the assembly voted that the Tsar should accede to the petition, and to the opinions of the Holy Patriarch and the archbishops, and should order that "henceforward all ranks should be without precedence, because formerly, in many military exploits, and embassies, and affairs of all kinds, much harm, disorganization, ruin, and advantage to the enemy had been wrought by this, and that it was a system opposed to God, intended to cause confusion and great hatred." After that the Tsar ordered to be brought into his presence, the official service books,—the books in which, for many centuries, the official services of every noble family, and of all its members had been carefully noted down. He ordered, at the same time, that all who had such books of their own, either original or copies, should surrender them to the Government. These books were then delivered to an official, who took them into the court-yard, and in a furnace prepared for the occasion, burned them in the presence of the Tsar and the nobles.

A reform like this, however useful, could not be effected without exciting some dis-

content and opposition on the part of the nobility. The only matter of surprise is that it excited so little at the time. Every one, however, who had any patriotism, or sense of public duty, felt that this was a necessity. They had been willing to sacrifice their feelings about rank on occasions when the Tsar had specially commanded that the



OFFICERS OF THE STRELTSI.

service should be without precedence; they were therefore willing to sacrifice it entirely. At the same time, if an occasion arose,—if there were a time when precedence was not waived,—they would risk everything rather than allow their family to be dishonored. But, while consenting to the measure, the great nobles had bitter feelings against the authors of it, and especially against Prince



THE STRELTSI OF A LITTLE LATER DATE.

Basil Galitsyn. Taken with other things, this helped to make them unite their forces, and, as has been said, they supported Peter.

I have referred to the want of organization in the army. The military forces of Russia at this time consisted of the armed peasants, who were brought into the field by their lords and masters, after special summons, at the beginning of every campaign,—an undisciplined and unwieldy mob; a few regiments of “soldiers,” officered by foreigners and drilled in European tactics; and the *Streltsi* (literally, archers), a sort of national guard founded by Iván the Terrible. The *Streltsi*, composed of twenty-two regiments named after their colonels, of about a thousand men each, served exclusively under Russian officers, and were governed by the old rules of Russian tactics, though subjected to regular discipline. They were concentrated in Moscow and a few other towns, where they lived in quarters by themselves. They were subject to no taxes and were allowed certain privileges, such as being permitted to have their own mills and shops, and to trade on their own account, when they were not actually engaged in military duties. They were for the most part married, their duties were hereditary, and their sons, as soon as they became old enough, entered into their fathers’ regiments. In spite of their privileged position, the *Streltsi* were fair representatives of the mass of the Russian people, among whom they lived and married and had daily intercourse, and from whom they received accession to their ranks. Still, not only had their discipline become weaker by their exceptional position, but much disorder and corruption had crept into their organization, and there were many complaints that their commanders withheld from them a portion of their pay, that they cheated them in their equipments, and that they compelled them to work as their servants and slaves, and thus prevented their carrying on their own trade and supporting their families.

In the winter before the death of Theodore, and about the time of the abolition of precedence, the *Streltsi* of the Pýzhof Regiment made a formal complaint that their colonel was retaining half their pay, and subjecting them to further oppression. Yazykóf, to whom was given the duty of investigating the matter, decided against the *Streltsi* and took the side of the colonel,—for a favorable answer to the petitioners might have offended Prince Dolgorúky, the head of the department of the *Streltsi*, an old magnate, whose good-will it was at that time most necessary to keep,—and ordered the more prominent of the petitioners to be

punished, so as to teach the *Streltsi* in future not to complain, but to be obedient to the constituted authorities. Three days before the death of Theodore, the *Streltsi* accused another colonel, Simeon Griboyédof, of extortion, of cruel treatment, of withholding their pay, occupying their land, compelling them under pain of flogging to work for him, and especially of forcing them to work during the Easter festivities on a country house he was building near Moscow. To prevent what happened before, they this time sent a delegate with the petition to Prince Dolgorúky himself at the department. Dolgorúky, to whom it was reported that the petition had been brought by a drunken and foul-mouthed soldier, ordered the delegate to be whipped. But as he was being taken to suffer his punishment before the eyes of his comrades, he said: “Brothers, why do you give me up? I gave the petition by your orders, and for you.” The *Streltsi* thereupon attacked the guard and rescued their delegate. This excited their anger, and in all the regiments complaints began to be louder and more persistent. Finally the Government yielded, or appeared to yield, and an order was given that Griboyédof should be removed and sent to Siberia, and that his property should be confiscated. He was imprisoned for one day and then reinstated. The *Streltsi* then became frightened, and fearing the fate of the first petitioners, began to take measures for their own safety. The death of Theodore, however, put for a moment a stop to all proceedings, and the *Streltsi* quietly took the oath of allegiance to Peter. The men of only one regiment at first refused to take the oath, but they were soon won over by the boyárs who were sent to talk with them, and kissed the cross.

The Miloslávsky party, in their efforts for self-defense, naturally took advantage of the discontent of the *Streltsi*. Ivan Miloslávsky gave himself out as ill and received no guests, but he easily found aid in his nephew and even among the *Streltsi*. Disquieting rumors were spread. Much talk was made about the burdens that would be laid upon the *Streltsi* by the Narýshkins when they came into power, and it was whispered about that the boyárs, with the help of the German doctors, had poisoned the Tsar Theodore; that they had unjustly elected Peter, passing over the claims of Joánn, his elder brother, in order that they might rule under his name, and that they had openly threatened many of the *Streltsi* with death for their previous

complaints. The absence of Matvéief was favorable to any plans for working on the Streltsi against the Narýshkins. He was so much loved by the Streltsi, that, had he been present, he could easily have counteracted such schemes by promising justice. Some regiments assumed a hostile attitude while others wavered, and—one the Súkharef regiment—refused to listen to these intrigues and remained faithful. In others the officers who endeavored to restore order and to bring the men to some sense of their obedience to the crown were insulted and attacked. On the 9th of May the Streltsi presented petitions against twelve of their colonels and officers for acts of violence, unjust imports and other illegalities, and demanded immediate satisfaction, threatening, in case it were not granted them, to take the law into their own hands and recover their losses out of the property of the officers. The new Government had no counselors on whom to rely. Among all the nobles of old and venerated names who made up the aristocratic party, and who had gathered round Peter,—Odóiefsky, Tcherkássky, Dolgorúky, Répnin, Troekúrof, Romodanófsky, Sheremétief, Shein, Kurákin, Lýkof, Urúsof,—there was not one who seemed capable of administering a department, and certainly not of appeasing a storm like this when tact as well as good sense was required. There were no men of experience in the new Government. The Narýshkins were young and untried. Yazýkof, Likhátchef and Miloslávsky refused to interfere as it was none of their business to help out the new Government; and to increase the alarm, Matvéief was still far away. The settlement of the matter was at last confided to the Patriarch, who endeavored to arrange matters with the Streltsi and to satisfy them with the promise that all would be set right. The Streltsi, however, demanded that the colonels should be given up to them. The boyárs were so much frightened that they were inclined to consent to this demand; but the Patriarch sent the Metropolitans and Archbishops to the Streltsi, in the hope of persuading them to thank the Tsar for his promise, and to abandon the idea of themselves punishing their commanders. Next day all the colonels were removed from their offices and put into prison and an order was given to confiscate all their property and pay all the claims of the Streltsi. On the 12th, Simeon Griboyédof and Alexander Karandéyef, two of the colonels, were whipped with the

knout, and twelve others with rods. Before the execution began, the accusations were read over, and the Streltsi, who stood about, were allowed to fix the measure of punishment, sometimes exclaiming “harder,” and sometimes “enough.” Yielding to a demand which was probably intended as a test of weakness, the Government forbade Yazýkof and the Likhátchef and several of their immediate supporters to come to court or to appear before the “Shining Eyes” of the Sovereign. On the 14th of May the Streltsi presented a new petition against their colonels, demanding the recovery from them of the losses which they had sustained, and the next day the colonels were submitted to the “*pravezh*,” that is, they were publicly tortured or beaten, until they consented to pay the amount claimed. This semi-judicial proceeding lasted for eight days, until every farthing which had been claimed was made up; and the colonels were then allowed to retire to their houses in the country. As the Streltsi had now been satisfied, and their claims, just and unjust, had been granted, the Government hoped to have a little quiet; and in order to act upon public opinion, resolved that on the 17th of May there should be a public procession of the Tsar and the Court officials to the Cathedrals of the Krémelin. At the same time there was to be a reception at the Palace of the nobility of the province of Smolénsk, of foreigners and of officials. This was very well in its way; but at the same time the great mistake was made of conferring the rank of “boyár” and “armoror” on the eldest brother of the Tsaritsa, Iván Narýshkin, a young man only twenty-three years old. Other relations of the Tsaritsa also received increase of rank. These new favors to the Narýshkins displeased not only the Miloslávsky party, but the Streltsi, with whom they were unpopular. It was said that the Narýshkins were trying to get the power on their own side in order to use it for their own personal ends; and it was rumored that Iván Narýshkin had tried on the Imperial Crown with the remark that it looked better on him than on anybody else, and that he had rudely pushed aside the Princess Sophia, who had remonstrated with him. It was said, too,—for the most absurd reports will circulate in an ignorant community,—that the Narýshins wished to destroy all the descendants of the Tsars, and themselves take possession of the throne.

Meanwhile Matvéief, who had been re-



FLAG OF THE STRELTSI OF MOSCOW.

stored to all his ranks and titles on the first day of the accession of Peter, and was then on his estate only two days' journey from town, had received numerous messages recalling him to Moscow, and urging him to hasten. Nevertheless, he lingered. He received daily accounts of what was going on at the capital, for even before Theodore's death, many of his old enemies, seeing which way the wind was blowing, and what were the chances of the future, had made conciliatory advances. According to his son's account, seven faithful Streltsi went out to meet him, warned him of the disaffection against the Government and the Narýshkins and of the threats which had been uttered against him, and advised him not to go on to Moscow. He probably lingered to see if the storm would not blow over, but thinking that as once he had been such a favorite with the Streltsi that they had even brought with their own hands stones from the graves of their fathers to build his house, he would be able to complete the pacification, he set out for Moscow. After stopping a day to rest at the Tróitsa monastery and receiving the blessing of the Archimandrite, he was met at the village of Bratóvstchina by a state carriage and by Athanasius Narýshkin, who had been sent to greet him in the name of the Tsar and of the Tsaritsa. Late in the evening of the 21st of May the old man returned to his house after six years of exile passed amidst the greatest privations. The next day he had an interview with the Tsaritsa; and had the pleasure of embracing her son, the Tsar Peter. The family and the adherents of the Tsar now thought that all would be

right, that the old man with his long experience and good sense, and the general love felt toward him, would be able to overcome all difficulties and to establish order. For three days the house of Matvéief was filled with visitors of all classes and conditions of Moscow. Every one came to congratulate him, even the members of the Miloslávsky party, except Iván Miloslávsky himself, who still gave himself out to be ill. All who came brought presents of one kind or another; "sweet money on the sharp knife," as his son expressed it. So many presents of all descriptions, especially of provisions, were brought to his court-yard, that there was no longer any room for them in the cellars and store-houses. With tears of joy streaming down his face, the old man received all who came; inwardly he must have experienced feelings of triumph at being received in this way in Moscow, after his unjust exile.

Baron van Keller, writing a few days earlier, says: "The discontent of the Streltsi continues. The Dutch merchants have been much frightened, but the Streltsi have done no harm except to those who have given them cause of dissatisfaction. As a proof that their complaints and griefs are not unfounded, His Tsarish Majesty has shown them much goodness, but has entirely disapproved of their manner of acting, as too vehement and irregular, resembling the proceedings of their neighbors the Turkish Janissaries, who likewise have wished to be their own judges, and have caused great confusion and loss. * * * When the tempest is over Regents will be chosen. * * * Meanwhile all public affairs are at a stand-still. * * * Great calamities are feared, and not without cause, for the might of the Streltsi is great and redoubtable, and no resistance can be opposed to them. Their grievances should be corrected so as to avoid bad consequences."

CHAPTER IX.

THE RIOT OF THE STRELTSI.

ON the 25th of May the Streltsi, armed from head to foot with swords, halberds and muskets, began to collect at a very early hour in their churches in the most opposite quarters of the city, as if waiting for some watchword. Soon a watchword came. About nine o'clock in the morning a man rode hurriedly through the streets crying

out: "The Narýshkins have murdered the Tsarévitch Iván! To the Krémelin! The Narýshkins wish to kill all the royal family! To arms! Punish the traitors! Save the Tsar!" A general alarm was at once sounded. Drums were beaten, bells rung, and the regimental cannon were brought out. The Streltsi with their broad banners embroidered with pictures of the Virgin, advanced from all sides toward the Krémelin, as if to attack an enemy, compelling their colonels to lead them on. The peaceable citizens who met them were astonished at this onset; but to their inquiries as to its cause the answer returned was: "We are going to destroy the traitors and murderers of the family of the Tsar." No doubt the majority of them sincerely believed that the Tsar was really in danger, that the Narýshkins were desirous of mounting the throne, and that they were patriots going to save their country, and to rescue their ruler from the traitors and the hated boyárs. As they advanced they cut off the long handles of

ing drums, were advancing toward the Krémelin. Matvéief, astonished, immediately returned to the palace with Urúsof, to inform the Tsaritsa Natalia. The words were scarcely out of his mouth before three messengers came in, one after another, each with worse news than the preceding. The Streltsi were already in the old town and near the Krémelin walls. Orders were immediately given to close the Krémelin gates and to prepare whatever means of defense there might be, and the patriarch was hastily sent for. The officer of the guard, however, came with the intelligence that it was impossible to shut the gates, as the Streltsi had already passed them and were now in the Krémelin. All the carriages of the boyárs had been driven back to the Iván place, and the drivers were some wounded and some killed, while the horses were either cut to pieces or removed from the vehicles. No one could get into the Krémelin or out of it, and the frightened boyárs took refuge, one after another, in the banquetting-hall of the palace.

The Streltsi surrounded the palace, and stopped before the red staircase. Amid the din, the cries and the uproar it was barely possible to distinguish the words: "Where's the Tsarévitch Iván? Give us the Narýshkins and Matvéief! Death to the traitors!" A brief council having been held in the banquetting-hall, it was decided to send some boyárs out to the Streltsi, to demand of them what they wanted. Prince Tcherkássky, Prince Havánsky, Prince Galítsyn and Sheremétief then went out and asked the Streltsi why they had come to the palace in this riotous way. "We wish to punish the traitors," was their reply; "they have killed the Tsarévitch. They will destroy all the royal family. Give up to us the Narýshkins and the other traitors." When the boyárs brought back this answer, the Tsaritsa was advised by her father, Matvéief, and others to go out on the red staircase and show to the Streltsi both the Tsar Peter and the Tsarévitch Iván. Trembling with terror, she took by the hands her son and her step-son, and—accompanied by the Patriarch, the boyárs, and the other officials—went out upon the red staircase. "Here is the Tsar, Peter Alexévitch; here is the Tsarévitch, Iván Alexévitch," the boyárs cried out in loud voices, as they came out with the Tsaritsa and pointed the children out to the Streltsi. "By God's mercy they are safe and well. There are no traitors in the royal palace. Be quiet; you have



THE PATRIARCH NIKON.

their spears, so as to manage them more easily. Meanwhile the boyárs were quietly sitting in the public offices and in the palace, without the slightest idea of what was passing in the city, or after finishing the morning's official duties, they were strolling about previous to their midday dinner. Matvéief, on coming out upon the staircase leading to the bed-chamber porch, saw Prince Theodore Urúsof hastily running toward him, with scarcely breath enough to cry out that the Streltsi had risen, and that all the regiments, fully armed and with beat-



THE TSARITSA BEFORE THE RIOTERS.

been deceived." The Streltsi placed ladders against the rails, and some of them climbed up to the platform where the Tsar's family stood, in order the more closely to look at them. Peter stood still and looked at them, face to face, without blanching or showing the least sign of fear. On coming to the Tsarévitch Iván, the Streltsi asked him if he really were Iván Alexéivitch. "Yes," answered the youth, in an almost inaudible voice. Again the question was repeated. "Are you really he?" "Yes, I am he," was the reply. The Patriarch then wished to descend the staircase and talk with the rioters; but the cry came up from below, "We have no need of your advice; we know what to do," and many men forced their way up past him. The Tsaritsa, seeing their rudeness and fearing the consequences, went into the palace with her son and the Tsarévitch.

Matvéief, who had formerly been a favorite commander of the Streltsi, went down outside of the wicket and spoke to them in a confident yet propitiatory tone, reminding them of their former faithful services, especially during the time of the Kolómna disturbances and of their good reputation which they were now destroying by their proceedings, and explaining to them that

they were disturbed without reason by believing false reports. He told them that there was no cause for their alarm about the royal family, which, as they had just seen with their own eyes, was in perfect safety. He advised them to beg pardon for the disturbance which they had made, which had been caused by their excessive loyalty, and he would persuade the Tsar to overlook it and restore them to favor. These sensible, good-natured words wrought a deep impression. The men in the front grew quiet; and it was evident that they had begun to reflect. Further off were still heard voices in discussion and conversation, as though a better feeling were taking possession of the multitude. It gradually became calmer.

Matvéief hastened back into the palace to calm the fears of the Tsaritsa, when, unfortunately, Prince Michael Dolgorúky, the second in command of the Department of the Streltsi, came out and, relying on the words of Matvéief, and thinking that all irritation was over, wished to put himself forward and to show his powers of command. In his rudest and roughest tones he ordered the Streltsi to go home immediately, and to attend to their own business. All the good impression which Matvéief's

words had produced was immediately dispelled. The opponents of the Narýshkins, who had been rendered silent by the changed disposition of the multitude, again began to raise their voices; and some of the more forward of the Streltsi, who were more drunken or riotous than the rest, seized Dolgorúky by his long gown, threw him down from the platform into the square, asking the crowd at the same time whether such was their will, while the Streltsi below caught him on their spears, exclaiming "Yes, yes," cut him to pieces.

This first act of bloodshed was the signal for more. Lowering their spears, the Streltsi rushed into the rooms of the palace, which some had already succeeded in entering from another side, in order to seize upon Matvéief, who was in the ante-room of the banqueting-hall, with the Tsaritsa and her son. The Streltsi moved toward him; the Tsaritsa wished to protect him with her own person, but in vain. Prince Tcherkássky tried to get him away, and had his coat torn off in the struggle. At last, in spite of the Tsaritsa, the Streltsi pulled Matvéief away, dragged him to the red staircase, and with exultant cries, threw him down into the square, where he was instantly cut to pieces by those below.

The Streltsi then burst again into the palace, and went through all the rooms, seeking for those who, they said, were traitors. The boyárs hid themselves where they could. The Patriarch was scarcely able to escape into the Cathedral of the Assumption, while the Tsaritsa Natalia and her son took refuge in the banqueting-hall.

The Streltsi ran through all the inner rooms of the palace, looked into the store-rooms, under the beds, into the chapels, thrust their spears under the Altars, and left no place without a visit. From a distance they saw Theodore Sólytkof going into one of the chapels. Some one cried out: "There goes Iván Narýshkin," and the unlucky man was so frightened that he could not pronounce a single word, or even tell his name. He was at once killed, and his body thrown below. When it was ascertained who it was, and that he was not a Narýshkin, the Streltsi sent the body to old Sólytkof, and excused themselves by saying that his son had been killed by mistake. "God's will be done," said the old man, who had even the presence of mind to give the messenger something to eat and drink. After they had left the house, in trying to console his weeping daughter-in-

law, he quoted a Russian proverb to the effect that "their turn will come next." A servant who had overheard this, and who had a grudge against his master, immediately rushed out, and told the Streltsi that his master had threatened them. They returned and murdered him on the spot.

In the Church of the Resurrection the Streltsi met one of the court dwarfs, named Homyák. "Tell me where the Narýshkins, the Tsaritsa's brothers, are hid?" they asked. He pointed to the altar, and they pulled out Athanasius Narýshkin, dragged him by the hair to the chancel steps, and there cut him to pieces. His younger brothers, his father, and his other relatives, as well as Matvéief's son, whose description of these events we chiefly follow, took refuge in the apartments of the little Princess Natalia, Peter's sister, which apparently were not searched.

On the portico between the banqueting-hall and the Cathedral of the Annunciation the Streltsi killed the privy-councillor and director of foreign affairs, Lárion Ivánof, who had been one of those sent to negotiate with them, his son Basil, and two lieutenant-colonels. Between the Patriarch's palace and the Miracle Monastery, opposite the Department of Foreign Affairs, the Streltsi caught the old Boyár Romadonófsky, seized him by the beard and dragged him to the Office of Expeditions. There they raised him up on the points of their spears, and then threw him to the ground and cut him to pieces, because, as they said, he had been too severe with them in the expedition to Tchigirín.

The dead bodies, with the spears still sticking in them, were dragged along by the feet to the gates of the Krémelin, amidst cries of "Here goes the Boyár Artemon Sergeisvitch Matvéief!" "This is the Boyár Prince Gregory Gregórievitch Romadonófsky!" "Here goes a privy-councillor—make room for them!" When the bodies had been dragged to the Lobnóe place, where the tribune used at popular assemblies stood, they were hacked into small pieces, amidst cries of "They loved to exalt themselves; this is their reward." The crowd that stood around was obliged to express its satisfaction, because everybody who was silent was accused of being a traitor, and as such was beaten.

Peter Narýshkin, who knew nothing of what was going on, was found in a house on the other side of the river Moskvá, and was tortured and killed. Great efforts were made to find Doctor Daniel Von Gaden, a Jew by



IVAN NARVSHKIN.

birth, whom the Streltsi believed to have poisoned the Tsar Theodore. The rioters went to his house, which was near the Pogány Pond, and arrested his wife. They also searched the house of his partner, Dr. Jan Gutmensch, but as they found no one, they left it. A new crew came, and succeeded in finding a frightened man, who had hidden himself in the garret, and took him to the Krémelin, together with Von Gaden's wife, threatening to keep them until the Doctor was found, and in case of his not being discovered, to kill them both.

Partly from anger against the boyárs, and partly from genuine sympathy, the Streltsi took up the cause of the serfs. Many of them had been serfs themselves, and knew the oppressions to which they were subject. They wished not only to set the serfs free and "restore right and justice to the land," but also to gain adherents to their own cause. With this aim they attacked the Departments of Justice and of Serfage, broke open the chests of papers and scattered them all through the streets; and then, going afterward to the house of the chief boyárs, declared to the serfs that they were free. This action produced little effect; they were joined by few of the common people, who were slow to move and were frightened, rather than excited, by the events of the day. The Streltsi were a mob, but still a mob of soldiers. As in many similar cases, a few nobles were betrayed and given up by their

servants. A few others owed their safety to the devotion of their faithful slaves.

That night strong guards were left at the gates of the Krémelin with strict orders to let no one in or out. Pickets were also stationed at the gates of the Kitai Gorod and the White Town. On their way home parties of Streltsi entered various houses and demanded refreshments. If any one dare refuse them they beat the masters and servants, and excited general terror. But such conduct excited the reprobation of the leaders.

Early the next day, the 26th, the Streltsi came again, fully armed, with the beating of drums, and advancing to the gilded lattice near the apartment of the Tsar, demanded with loud cries the surrender of Iván Narvshkin, the Councillor Kiríloff, and the two doctors, Daniel the Jew and Jan Gutmensch. The princesses endeavored to save the lives of these people, but they were obliged to surrender Kiríloff and Dr. Gutmensch, although they succeeded in saving the wife of Doctor Daniel von Gaden by concealing her in the room of the young Tsaritsa Martha, the widow of Theodore. The others were killed.

The Streltsi then went to the residence of the Patriarch and threatened with spears



MATVEIEF.

and halberds, not only the servants but the Patriarch himself, demanding the surrender of the traitors concealed there; looked through the cellar and outhouses; turned topsy-turvy boxes and beds, and not find-

ing any one, again came to the Patriarch and repeated their demands. The Patriarch, who had put on his robes, replied that there were no traitors in his house, but that he himself was ready to die.

One band went to the house of the Danish resident, Butenant von Rosenbusch, because they had heard from some one that Doctor von Gaden and his son were sheltered there. "In the night between Monday and Tuesday," Rosenbusch himself relates, "a sharp search was made for a doctor named Daniel von Gaden. At break of day the Okólnitchy Kirflo Ossipóvitch Khlópof and more than one hundred Streltsi came into my court-yard, saying that they had information that the doctor and his son were concealed in my house, and telling me that if he were there I must give him up; and that if I should conceal him, and he should be found in my house it would cost my life and that of my whole family, and that all my property would be confiscated. I swore, therefore, by all that was holy, that I knew nothing about him, and had not even seen him for a long time. Thereupon he said that he had orders in any case to search my house, which I was obliged to let him do, because my protestation that I was a servant of the king, and that not I but my most gracious king would be affronted, was not taken into consideration; but they went on and searched through everything, chests and boxes—all I had to open for them; and they looked through every corner of my house. Meanwhile came news that the doctor's son had been caught in disguise in the street that very night, so that the Okólnitchy need no longer look for him, but should track out the doctor with all haste. As they could find nothing in my house they ceased their search and went away; but in an hour afterward a captain and about fifty Streltsi returned, and said that they had orders to take me with them to the palace that I might be confronted with the son of the doctor, who had said that he and his father had been concealed by me. They immediately seized on me and wished to take me off, undressed as I was, without my hose and without my underclothing. I begged most humbly that they would first let me dress myself and ride my horse into the town. My wife also fell on her knees before them, begging them with tears. So at last they permitted me to dress myself in the court-yard, for they would not allow me to stir a step from them.

But when my horse was brought and I wished to mount it they would not allow me, saying I could go as well on foot; but at last, after many prayers, I obtained this. Thereupon I took leave of my wife with tears in my eyes; but when I came out into the street the bountiful God gave me the happy thought to keep still a little, and then calling the captain of the Streltsi close to me I said: 'God be praised! I am not guilty, no never; I have a clear conscience and do not doubt that as soon as I go to the castle you will let me go. Then if you will accompany me home again I will treat you to as much brandy and beer as you like, but since the streets are full of your comrades who do not know anything about me you must take care that none of your men who meet me do me any harm. Say that I am an ambassador who has been called to the court. This the captain and his Streltsi promised to do, and they kept their word.

"Whenever a body of Streltsi met us they cried out: 'Get out of the way! An ambassador is going to talk with His Tsarish Majesty,' whereupon the Streltsi immediately made way. When I was near the palace in the great square of the Bazaar, I saw to my right a colonel named Dókturof led off by the Streltsi to be killed, and on both sides of the road through which I had to pass many dead bodies lay terribly mutilated, whereupon I was very much frightened. And what terrified me most was that some of the Streltsi coming from the Krémelin, when they saw me all cried out: 'That is Doctor Daniel. Give him here, the traitor and magician!' My Streltsi had enough to do to keep them back, continually calling out: 'Keep back! It is not Doctor Daniel, but an ambassador who must speak with the Tsar,' so that when I came to the Krémelin gate it was immediately opened and instantly shut behind me again. After I had ridden on a little I met several Streltsi dragging along the naked dead body of the doctor's son. Then my captain said to me, though he did not leave my side: 'This is the doctor's son, with whom then can you be confronted?' I thereupon was silent a little. When I came to the great square, which was full of armed Streltsi, they began to beat their drums and sound the alarm bells, which was their sign to kill some one. But Almighty God gave me great courage, and my Streltsi cried out: 'Keep still! This is an ambassador who must speak with his Majesty.' Space was made for me

to ride on as far as the stone staircase, where stood the lately widowed Tsaritsa and the Princess Sophia Alexéievna, with several gentlemen. I wanted indeed to go farther, but my Streltsi could make no space, for the square was so full of people that one could have walked on their heads. Then the Boyár Prince Iván Andréievitch Havánsky came down and asked the Streltsi: 'Is it your pleasure that the oldest Tsaritsa Natalia Narýshkin shall no longer remain at Court?' They all cried out: 'Yes, that is our pleasure.' But as Havánsky turned round he looked into my face, was much astonished, and asked me: 'Andréi Ivánovitch'—for that is my name in Russian—'how did you get here?' I pointed to my Streltsi and said: 'They brought me here,' and then stepped nearer to him until I was two steps from the Tsaritsa and the Princess, to whom Havánsky said something in a voice too low for me to hear, but which was probably nothing bad, for the Princess waved her hand to me to go away. Prince Iván Andréievitch called out to my Streltsi: 'Take this man home again and guard him as you would your eyes,' and then made a flattering speech about me. As soon as I got out of the sight of those high personages the Streltsi who accompanied me said: 'Andréi Ivánovitch, cover thy head. Thou hast now perfectly established thy innocence.' As I came to the great staircase, the Streltsi who stood about there thought that I, like others, should be thrown down, and when they saw my Streltsi take me past the staircase, they all pressed near and asked why I was there and why I was let go, and some still had an idea that I was Doctor Daniel. But my Streltsi kept their word and cried out that I was an ambassador and had talked with the Princess, and that they should let me have my horse and go my way; but the crowd was so great that I could not get my horse at once, but at last, after pressing a long time through the crowd, I got it and rode home, all the Streltsi accompanying me, joined by many others. Some ran on as fast as they could to bring my wife news that I had been found innocent and let free, for I was obliged to go slowly and quietly, and make no uneasy countenance. When I came home I was received by all my people as one escaped from death's claws. To the Streltsi, who had now increased to over two hundred, I immediately had given as much brandy and beer as they could drink.

Three of the highest came into my room and said: 'Now give us some money.' I answered 'yes,' and thought twenty rubles would be sufficient; whereupon they laughed scornfully, and demanded from me a thousand rubles. At this I was horrified; whereupon they said: 'Andréi Ivánovitch, content us well, or we will leave no life in thy house. Dost thou not know that we have the power? everything must tremble before us; and no harm can come to us for that.' I said: 'You gentlemen were ordered to bring me home without harm; and now will you yourselves murder me? Therefore do what you will; it is impossible for me to get so much money.' Then they cut down half; and at last I agreed with those three persons to give every one of their men half a ruble each. When they went out the other Streltsi would not agree to this, and said that they must each have a ruble. The three men, however, said: 'We have agreed with the landlord for half a ruble, and cannot take our words back, you must, therefore, be contented.' Whereupon they all kept still. I then had the money counted out, and wrapped each half ruble separately in a paper, and had the Streltsi counted, when we found them to be 287 men strong. They then sat in a circle all about my court-yard, and the money was given out to them by two men, and after they had all once more taken a drink and had thanked me most heartily, they went away. When they were out of the court-yard, I fell on my knees, together with my family, and thanked God for his gracious preservation and assistance, for according to all appearances if I had gone out without my clothes, and on foot I should not have come out of their hands alive. If a single man of the Streltsi who accompanied me, had lifted his finger to mark me out I should have been killed. The same day another party came to look for the doctor, but they were somewhat more civil than the first time; and in the night (or early on the Wednesday morning) still another party of Streltsi came and searched through my house. They also were civil enough, but they terrified us a great deal, because we felt there would be no end of it until the doctor was found, for the Streltsi were immoderately embittered against him. When at day-break the news came that the doctor had been found, all we neighbors were right glad, although we knew he was innocent; yet he could not have escaped, and we were saved from

much anxiety. That same day I asked the Boyár Prince Bazil Galítsyn (who had taken charge of the Department of Foreign Affairs, instead of Larion Ivánof) to give me some Streltsi as a guard, which was done; and on Thursday five Streltsi were put in my house, and changed every day."

The old Narýshkin, the father of the Tsaritsa, with his sons, several other relatives, and the son of Matvéief, a youth of seventeen, concealed themselves at first in the dark closets in the bedroom of the little Princess Natalia, but were afterward taken to the further room of the Tsaritsa Martha, which had no windows, and was next to the court of the Patriarch's palace. Here Iván Narýshkin, who was particularly sought after by the Streltsi, cut off his long hair, and then an old bed-chamberwoman, Klush,—who was the only one who knew exactly where they were concealed,—took them out in the morning into a dark store-room on the ground floor, covered up the windows with pillows, and wished to shut them in there, but Matvéief said "No; if you fasten the door, the Streltsi will suspect something, will break it open and find us and kill us." The room was therefore made perfectly dark, and the door was left open a few inches, while the refugees crowded together in a dark corner behind it. "We had scarcely got there," says young Matvéief, "before several Streltsi passed and looked quickly round. Some of them looked in through the open door, struck their spears into the pillows, saying spitefully: 'It is plain our men have already been here.'"

That day the Streltsi captured Iván Yazýkof on the Nikitskaya street as he was hurrying to a church to conceal himself. He was met by a servant who knew him. Yazýkof pulled off a valuable ring from his finger and giving it to him begged him not to tell anybody. The rascal promised not to do so; but immediately called some Streltsi, who ran up, looked through the church and found Yazýkof, dragged him with jeers to the Red Place and killed him.

On the third day, the 27th of May, the Streltsi again came to the Krémelin, and to the beating of drums, stationed themselves about the palace, while some of them climbed straight up to the balcony and insisted on the surrender of Iván Narýshkin. They threatened all the servitors of the palace with death if they did not find him, and declared they would not leave the Krémelin until they had possession of him. They even threatened the life of the Tsaritsa

Natalia and of the other members of the Tsar's family. At last it became evident that nothing could be done, and the Princess Sophia went to Natalia and said: "There is no way of getting out of it; to save the lives of all of us you must give up your brother." Natalia, after useless protests, then brought out Iván Narýshkin and conducted him into the Church of the Savior beyond the Wicket. Here he received the Holy Communion and prepared himself for death. Sophia handed him an image of the Virgin and said, "Perhaps when the Streltsi see this holy picture they will let him go." All in the palace were so terrified that it seemed to them that Iván Narýshkin was lingering too long. Even the old prince Jacob Odóiefsky, a kindly but timorous old man, went up to the Tsaritsa and said: "How long, O lady, you are keeping your brother. For you must give him up. Go on quickly, Iván Kirílovitch, and don't let us all be killed for your sake." The Tsaritsa led him as far as the Golden Wicket, where the Streltsi stood. They immediately seized on him and began to indulge in all sorts of abuse and insult before her eyes. He was dragged by the feet down the staircase through the square to the Constantine torture-room. Though most fearfully tortured, Narýshkin set his teeth and uttered not a word. Here was also brought Dr. Daniel Von Gaden, who was caught in the dress of a beggar wearing bark sandals, and with a wallet over his shoulders. He had escaped from the town and had passed two days in the woods, but had become so famished that he had returned to the German quarter to get some food from an acquaintance, when he was recognized and arrested. Von Gaden, in the midst of his tortures, begged for three days more, in which he promised to name those who deserved death more than he. His words were written down, while others cried out: "What is the use of listening to him? Tear up the paper," and dragged him, together with Narýshkin, from the torture-room to the Red Place. They were both lifted up on the points of spears; afterward their hands and feet were cut off, and their bodies chopped up into small pieces and trampled into the mud. With these two deaths the murders came to an end. The Streltsi went from the Red Place to the palace of the Krémelin and cried: "We are now content. Let your Tsarish Majesty do with the other traitors as may seem good. We are ready to lay down our heads

for the Tsar, for the Tsaritsa, for the Tsarévitch and the Tsarévnas."

That very day permission was granted for the burial of the bodies, many of which had been lying in the Red Place since the first day of the riot; and the faithful black servant of old Matvéief went out with a sheet and collected the mutilated remains of his master, and carried them on pillows to the parish church of St. Nicholas, where they were buried.

On the 28th of May, deputies of the Streltsi regiments came unarmed to the palace and petitioned the Tsar to order his grandfather, Cyril Narýshkin, to be tonsured as a monk. The old man was immediately taken across the Krémelin to the Miracle Monastery, and after taking monastic vows under the name of Cyprian, was carried off in a small cart to the monastery of St. Cyril on the White Lake. His younger sons, Leo, Martemian and Theodore, succeeded in escaping from Moscow in common gray peasants' clothes under the care of some of their faithful servants, and concealed

themselves in distant places, as did some of their relatives. Through the kindness of a dwarf named Komar who was much attached to Peter, young Matvéief was disguised as a groom, and boldly went out with the dwarf down the chief staircase. There the dwarf mounted his horse, which Matvéief led, and they went through the Krémelin and the White Town to the Smolensk Gate, where the strong guard fortunately did not recognize him. He was handed over to the care of the priest of the Church of the Descent of the Holy Spirit, with an order from the Tsaritsa Natalia to conceal him. He was passed over by the priest to his relative, a groom, where he lived in peasant's clothing for some time under the name of Kondfat, and then wandered from one place to another until quiet was restored. Three days after this, on the 30th of May, the Streltsi petitioned again that the Tsar should exile the brothers Likhátchef, the rest of the Narýshkins and young Matvéief, and some other adherents of Peter. This decree was immediately issued.

(To be continued.)

YOUTH TO THE POET.

(TO OLIVER WENDELL HOLMES.)

STRANGE spell of youth for age, and age for youth,
 Affinity between two forms of truth!—
 As if the dawn and sunset watched each other,
 Like and unlike as children of one mother
 And wondering at the likeness. Ardent eyes
 Of young men see the prophecy arise
 Of what their lives shall be when all is told;
 And in the far-off glow of years called old
 Those other eyes look back to catch a trace
 Of what was once their own unshadowed grace.
 But here in our dear poet both are blended—
 Ripe age begun, yet golden youth not ended—
 Even as his song the willowy scent of spring
 Doth blend with autumn's tender mellowing,
 And mixes praise with satire, tears with fun,
 In strains that ever delicately run,
 So musical and wise, page after page,
 The sage a minstrel grows, the bard a sage.
 The dew of youth so fills his late-sprung flowers,
 And day-break glory haunts his evening's hours.
 Ah, such a life prefigures its own moral:
 That first "Last Leaf" is now a leaf of laurel,
 Which—smiling not, but trembling at the touch—
 Youth gives back to the hand that gave so much.

CHAM.



CHAM.

THE other day, there died in Paris a man who was the universal comic reviewer for France. Though but a draughtsman for the comic papers, he exercised a distinct public function—he was necessary to our intelligence of affairs. No question was quite understood until Cham had given us the ridiculous side of it. The politicians might speak, the journalists might write; but there was still more light wanting—Cham's sketch in the "Charivari."

"Cham" was a pseudonym. He was the Vicomte, and afterward the Comte, de Noé; and as Noé is the French for Noah, and Cham is the French for the scriptural Ham, the artist, who was the second son of his father, took that name. The old count was a stanch Legitimist; he married an Englishwoman; and from the one or the other circumstance of parentage we may trace many of the peculiarities of Cham's genius. He had our English humor to per-

fection—more humor, in fact, than *esprit*; that is to say, a keener sense of the absurd in differences than in resemblances. Much of his fun, indeed, was the veritable horse-play of mind. His father gave him the *seigneur's* contempt for the mob and still greater contempt for the middle class. But of course Cham, as a modern Frenchman, was a foster-son of the Revolution, whether he liked it or no; and so, by way of making the best of that situation, he spent his life in laughing at revolutionary follies. The laugh was a good-natured' one, or Cham's best things could never have been presented to the public through the medium of a Republican journal, the "Charivari." Perhaps it was the "Charivari's" way of giving the losing side a hearing. All the other contributors were ardent Republicans, who lashed the Reaction with unsparing fury. But their comrade was always at hand to apply the corrective, in the shape

of pages of pictorial fun, illustrative of the great truth that foolishness is never the monopoly of a party.

Cham, as a matter of course, took some little time to find what he was fit for, and at first he thought that historical painting was his line. So he went to the studio of Paul Delaroché, and persistently tried to draw things as other people saw them, until he found himself compelled to draw them as they appeared to himself; that is to say, they all came out caricatures. He was quicker than most artists of his stamp in letting his genius have its own way. Most of them, to the end of their lives, be-

lieve that the heroic is their true vocation. Did Liston ever cease to look on *Paul Pry* as a stepping-stone to *Richard III.*? After going through the usual course of "the classics" in pictorial study, Cham laid aside that style forever, and, under the influence of Charlet, began to draw for the amusement of mankind.

There must have been a strong temptation to this course in the state of public affairs. While Cham was serving his apprenticeship to art, France was passing through an interval of unrest between two revolutions—living alternately on the memory of the one, and the joyous expectation

of another that was to finish off the whole fabric of universal happiness. Every kind of visionary had his hour. The young fellow had only to open his eyes to behold the richest harvest of eccentricities ever offered to the reaper. After one or two performances of no great moment, he produced the "Assemblée Nationale Comique" of 1848, which, as republished by Michel Lévy, makes a bulky volume. Lireux wrote the letter-press. This volume is very droll; and at the same time, as read in the light of our present knowledge, it has a tragic import. One sees how it must all end. This group of school-boys, who have broken bounds, can never be quieted without the rod. Louis Napoleon is hardly mentioned in the history, yet, in a sense, he is in every page of it. His somber figure, with his legions of butchers behind him, seems to be in the very water-mark of the paper. The book is a course of philosophic history, though Cham only meant it to be a course of satire. It carries us back to a time of the maddest political confusion. We are in another world, peopled by the fantastic shapes of the proletarian dream. Liberty, light, plenty, happiness are to become the universal heritage of mankind. A few good laws will do it, or less than that; let us

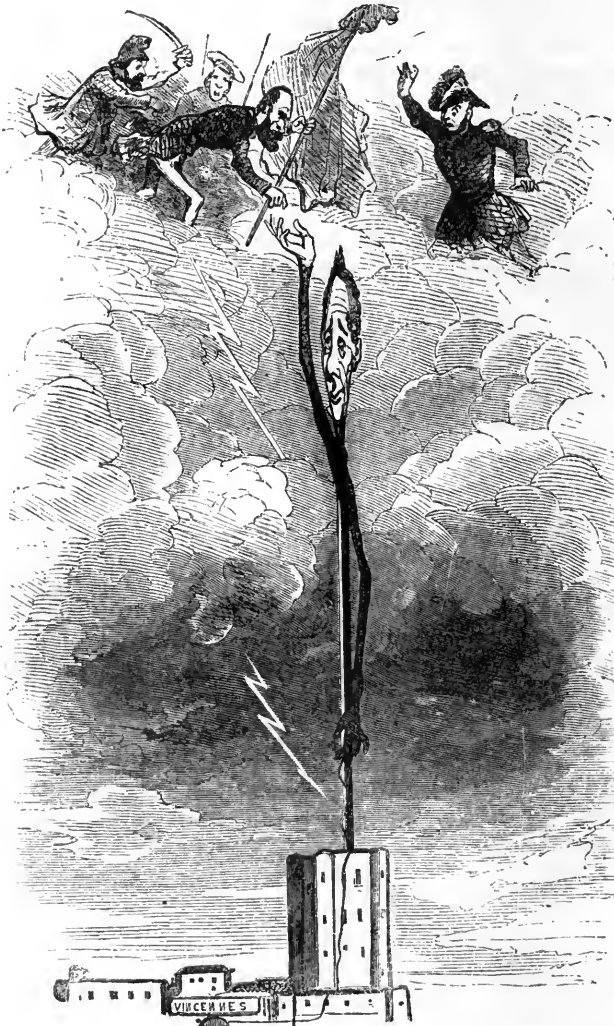

M. DE LAMARTINE AS A LIGHTNING-CONDUCTOR.



LOUIS BLANC IN THE TRIBUNE.

make haste and find "the formula" for one grand regenerating decree. Those who have nothing to give dignity and grace and sweetness to life are suddenly to have all; and if they are balked of their craving, France shall expiate their disappointment in flames and blood. Now, bearing the real nature of this expectation in mind, see the pathos of M. de Lamartine's attempt to fulfill it with a few fine words. He is a wonderful talker; his rhetoric is a display of fire-works. Somebody accuses him of conspiring. "Yes," he says, "I conspire as the metallic rod conspires with the thunder cloud." Cham forthwith sketches him as a lightning-conductor. There is a good deal of lightning in the air: the *faubourgs* have risen; the democratic clubs invade the Assembly, only half in a friendly way. At first they only smile on these amiable talkers, but the smile serves to show their teeth. Then they clamber into the galleries, chaff the terrified representatives; bully them—in fact, assume all the airs of an ill-conditioned "boss" at odds with his work-people. Then, for "a lark," they dissolve the Assembly—dissolving themselves five minutes after on the approach of the Guard. No one is more disgusted at the outbreak than the man who has unintentionally done his best to provoke it. Little

Louis Blanc is the god of the *plebs*; and, as Cham shows us, he is, in the physical sense at least, the very smallest deity that ever kept the monster in awe. He sketches him standing in the tribune in humiliating contrast, or rather identity of bulk, with

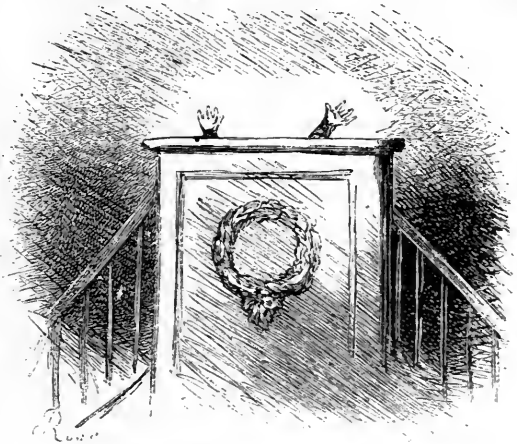

LOUIS BLANC "LOST IN SORROW."

the tumbler for his sugar and water; or, so lost in sorrow and indignation, that we see nothing of him but the tips of his tiny fingers outstretched in despairing gesture above his desk. The Assembly is too frightened and angry to take his explanations in good

part. It must have a victim. There is a rumor that he knew more of the rising than he cares to say, and the rumor soon grows into an accusation. Jules Favre presents the accusation in the form of a report



PIERRE LEROUX, COMMUNIST.

on the proceedings of the day of tumult. He does it with an insidious calm which stirs all the bile of Cham. The caricaturist seldom hates, but he makes an exception in favor of this man. Much as he scorns the violence and the pretension of the roughs and their hero, he can still laugh at it; but he has a sensation akin to seasickness in contemplating their accuser. He draws Jules Favre with the forked tongue of the serpent: it is the one detestable figure of the book. Lireux shares his aversion. "Look on his pale face," he cries, "mark the cruel perfidy of his oratorical precautions, his flowers of rhetoric dropped on the victim he is going to slay." By and by Cham, taking advantage of some parliamentary check which Jules Favre has suffered, gives us a picture of him as a sort of viper crushed with an honest countryman's boot. And so our history goes on. Louis Blanc clears himself of the charge against him in a fine explosive burst of eloquence almost enough to shake his manikin organization to pieces; and presently we have the figure of Cavaignac showing the Assembly the sword which, as long as he wields it, is the symbol of order. Cavaignac is a true hero; and Cham must think so, as he lets him off very lightly in the drawing—only giving him an elongated nose.

All the leading figures of the time are in the "Assemblée Nationale Comique." Here

is Pierre Leroux, the great Socialist, the inspirer of Georges Sand's "Consuelo," the dreamer of dreams. Cham draws him like the wild man he is—an admirable figure, as of some not ignoble savage out of the forest who has lost his way in civilization. The coadjutor hints that he is shabby and rather dirty. "One might call him an ancient Vicar of St. Eustache, who has taken advantage of the Revolution to marry his cook." Here is Lamennais in a fine rendering of his peculiarly forlorn position in this political turmoil. His timid, halting voice, we are told, is the true expression of his nature—of his life passed between the two stools of the cloister and the tribune. In a few bold touches Cham pictures the man standing before the National Assembly as though on his trial. And, indeed, at this moment he is on his trial, for he is avowing his full responsibility for certain articles for which the Assembly is going to prosecute an unlucky printer. Montalembert, another clerical politician, is less satirically touched off, but the drawing is at least a portrait. Cham, perhaps, did not find enough in him at that time. Montalembert had yet to acquire the full celebrity of his condemnation by the judges under Napoleon III., for offensive compari-

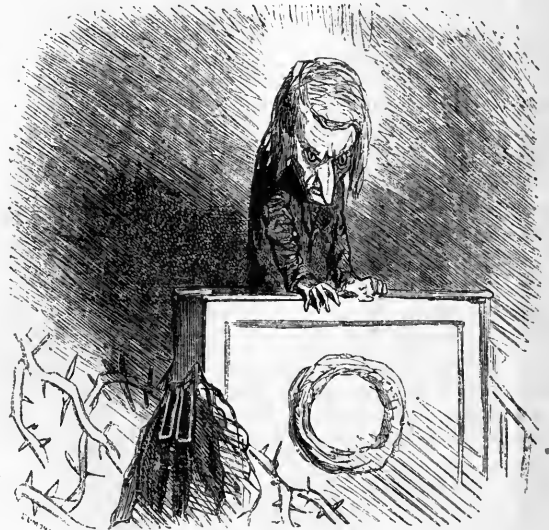

M. LAMENNAIS.

sons between the liberties of England and of France. Félix Pyat is more happily done. It is an actor at the foot-lights. He is soaring; we can almost hear them "giving him a hand." For we are in a tragi-



M. MONTALEMBERT.

comedy booth—nothing but that. For other diversions of the fair, here is little Thiers on stilts getting ready for a fight with Proudhon, another Socialist, and a more dangerous one than Leroux. That most formidable of all formulas, "Property is Robbery," was the mintage of his brain. Thiers faces him as the champion of the *bourgeois* terrified for its money-bags; and as it was fondly believed at the moment, with decisive success. Alas! the victorious logician had to do his work all over again with fire and sword in the time of the Commune, for in that movement the theories of Proudhon had their part. He was buried only the other day; but his body will be very fine dust before Socialism ceases to have its press and its prophets. Here is Hugo in the orator's box, making believe he is engaged in parliamentary discussion, though really playing the hero of one of his own pieces. It is the Hugo of our fathers. This generation knows him only as the old man eloquent; but there was a time when he posed as the literary dandy, as the young lion of mind. Girardin appears next, in a copy of his latest journal, worn like a Venetian cloak. He, too, is living to this day, and is a force in France. It was a happy thought to

robe him in a news-sheet, for he is the essential journalist, the Horace Greeley of France. He has founded more papers than most Frenchmen have read. His notion of intellectual activity is to have "a new idea every day." He is old now, and sometimes he has no more than two ideas a week, but an indulgent public does not keep a strict account. There are also representations of that essential soldier, Changarnier. Orleanist as he was, he defended the Republic; and he did it honestly, for he told the Republicans that he should be delighted to see the last of them. He offered his sword to the government for the preservation of social order, but it was generally understood, even by those who employed him, that he was only waiting for his opportunity to play the part of General Monk. He was a self-conscious hero; and Cham says as much in the sketch. During the *coup d'état*, Louis Napoleon felt too uncertain of his support to leave him at large. He was locked up with the rest; and in the darkest hour of the Emperor's fortunes, he took his revenge for the outrage, by hurrying with tottering steps to Metz, to offer his old oppressor the use of his sword. There is a gayer note in other drawings. The negro deputy from one of the French colonies passes to his seat in the Assembly, before a public rather terrified to think of his fellowship in civic rights with anything so black, while Cremieux, the Liberal and the Israelite, tumbles into a vase of holy water!

But Cham was not a great caricaturist; he was mainly a great joker. He would have



FÉLIX PYAT.

done still better in the "Assemblée Nationale" if he had written the legends for his own designs. When he had to run alone, both for sketch and descriptive motto, he was at his best. Very often the motto was

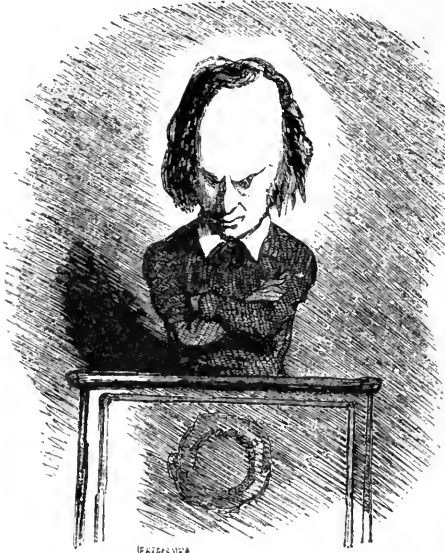

HUGO AS AN ORATOR.

the principal thing, and the sketch a mere amplification of it. He seems to have apprehended things as a man of letters, and to have drawn afterward only to make a literary conception more clear. In this respect he worked very much as Thackeray did. He is often compared to Daumier, the contemporary Republican prophet of fun. But Daumier drew well; whereas Cham never had any pretensions to academical style. Daumier was full of purpose and serious, while Cham showed a more artistic temperament in being very impatient of a moral. Nearly all Daumier's work is strong pictorial satire; his "Robert Macaire," for instance, is one of the most pitiless exposures of a corrupt society ever presented to the world. Cham had not the austerity of mind for that. He was more like the English Leech in the quality of his genius, though inferior to him as a draughtsman. This last defect was, indeed, his quality. The very looseness of his workmanship gave his jests a certain homely air and a sincerity which was half the secret of their effect. Is it too much to say that there is a law in this, and that the

great academical caricaturists have never been truly amusing? There is something a little too good in their work for the perfect grotesque; we feel reverent in looking at it; we are within the portals of the Schools. The Tenny cartoon in "Punch" often compels your admiration; but it rarely makes you laugh. You feel that the artist is only a caricaturist by accident, like Maclise, when he produced a capital album of the celebrities of his day. Cham's slovenliness of execution is in the spirit of his Bohemian freedom. He is, therefore, most truly himself in the "Charivari." Here the periodic form left him more free from obligations in the choice of themes. What he loved to do was to present some one subject, that happened to strike his fancy, in a full sheet of varied sketches, exhibiting all its comic points of view. Thus, a dozen drawings hit off for us the humors of the *Bœuf Gras*,—the procession of the fat ox of the year,—revived under the Empire. We have the beast laughing in uproarious derision at the sight of a horse-flesh butcher's shop, or exchanging compliments with Baron Brisse, the literary *cuisinier*, who in to-morrow's "Figaro" will be writing on a dozen different ways of dressing him. The ox of this particular procession is named "Sardanapalus," after a popular drama which was running at the time. He has seen the play, and he cannot pass a



M. GIRARDIN: THE HORACE GREELEY OF FRANCE.

stack of fire-wood in the street without trying to climb to the top of it, in humble imitation of the self-immolating exploit of the hero. The cartoon of the "Charivari" was often Cham's work. Here the free medium

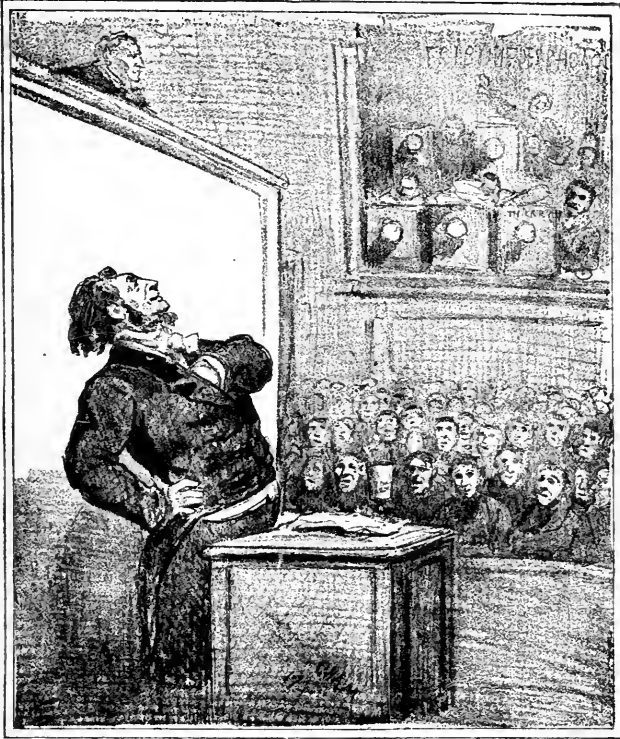

WHAT IS NEEDED IN THE ASSEMBLY.

of the lithograph was one well suited to his powers. He could work at his highest speed in chalk. The Legislative Assembly was still the butt of what may be called his larger jokes; he never recovered the shock to his feelings of reverence for all bodies of this kind which he received in 1848. His deputy is nearly always a poor stage-player, all attitude, both in body and mind; and to report him fully Cham thinks there should be a staff of photographers in the Assembly, as well as a staff of short-hand writers. The Exhibition of 1867 was illustrated by sheet after sheet of these serial drawings, the general theme of the jest being the extravagant expectations of the Parisians. All the world was coming to Paris, and what might it not mean—gold for everybody, and the most delightful chances for the young and the fair. Cham's *conciergerie* thinks so. "Wont they court the Parisians!" she says, looking at her nut-cracker face in a mirror. "I am one." These anticipations of wealth and pleasure were all the more seductive for their vagueness. The Frenchman knew nothing of the foreigner; his imagination was free to roam in all sorts of visions of

the quaint, the splendid, and the grotesque. Playing maliciously on this ignorance, Cham draws up a code of ceremonial for intercourse with strangers. "When you are presented to a foreign sovereign, the most civil thing to do is to leap through the ring in his nose. Otherwise he might think you had merely come for your amusement." Then we have a light battery of fun directed against the newly awakened desire for knowledge among the country school-masters. They are to be brought to the Exhibition at the expense of the government, and Cham pictures them, in their ardor for information, precipitating themselves on the first steam-engine that comes in view, like a swarm of flies on a pot of molasses. In another drawing a wretched small boy, terrified by the report of the invasion of pedagogues, creeps under the nursery bed.

But the "press man," whether of pen or pencil, soon repeats himself,—it is the regrettable condition of continuous production,—and Cham, to tell the truth about him, did little more than bring out a hundred thousand editions of one work. That work, too, was not his own. He was inspired in nearly all that he did by the great creation



A PARISIAN.

of Monnier. This man, though little known outside of France, was a giant of caricature—one of the few who have enriched this department of the science of animated nature with a new type. His creation of

phrase. He is a little of everything—just enough to clear him of the slightest risk to his skin or to his hoard in the long stocking. He is a little of a soldier; he adores the National Guard. He is a little of *un homme*



"M. JOSEPH PRUDHOMME." BY MONNIER.

"Monsieur Joseph Prudhomme" will last while the world lasts. M. Prudhomme is the representative of the *bourgeois*, or "cit.," of the golden age of French self-esteem, antecedent to the late war. He has the pompousness, the vanity, of the class; its prudence pushed to the verge of cunning, its worship of sleek comfort, its pleasant belief that all the needful capital of glory has been accumulated in the past, and that the nation can live comfortably forever on the yield of interest in tall talk. In his familiar fire-side aspect, M. Prudhomme is the oracle of smug common-place. He is triteness made flesh. Thanks to him, the "fullness of emptiness" is no unmeaning

galant; he struggles with the waiting-maid for a kiss in the passage. If he has a ruling passion, it is didacticism, or the science of the obvious why and the unmistakable wherefore; he will undertake to prove to you that nature owes much of her charm to the diversity of the seasons. Every *bourgeoisie* has its peculiar character, and the *bourgeoisie* of France is *doctrinaire*. With an exquisite perception of the fitness of things, Monnier makes his hero a professor of fine writing. Penmanship is the art by which M. Prudhomme gains his bread. It would be impossible to enumerate the many ways in which the man of genius presented his type. He sketched him with pen and pencil,—for he

could draw as well as write ; he put him into comedy, he played him on the stage. By means of every vehicle of artistic representation, he showed us M. Prudhomme in every situation,—in love and in mimic war, as a patriot, a father of a family, and a penman. It was his life-work ; all his strength went forth in this creation. He finished it to its utmost perfection of fanciful vitality in a thousand touches, each one bettering the last, until the perfect Joseph stood before us, with his fat, fussy face, with the spectacles by which he seemed to be affiliated to the learned professions, with the huge shirt-collar which gave dignity to his whole moral being.

The most superficial acquaintance with Cham's work shows us that this type had fixed itself definitely in his mind. It was Monnier, in a sense, who taught him to see ; only, still more varied than Monnier,—or at least more industrious,—he carried out the apotheosis of the *bourgeois* in a thousand details of manners, with which his master was unacquainted. This subtle invention of fancy had, in fact, appealed to him on every side,—as a humorist and as an aristocrat. M. Prudhomme is

of the new social order that has ousted Cham's "set ;" let the interlopers look to themselves. Cham added nothing to the philosophic conception of him ; he only gave a thousand new examples of each well-known trait. M. Prudhomme comes into the Exhibition sketches. He dresses as a Chinaman,—as he tells his wife, to secure some little of the attention which is sure to be exclusively reserved for people of foreign mien. He prudently salutes the statue of the king of Prussia, which has been sent to the show. True, Prussia has been intolerably insolent to France, but M. Prudhomme is determined to have all the bad breeding on one side. He has, indeed, had a gala time of it during this international gathering, and when it is all over he takes a friend into a cabinet to see the museum of hats, each of which he has lifted to a reigning sovereign. There is the Emperor of Russia hat, the hat of the King of Greece, the hat of the Sultan. They are to be kept under glass cases forever, the priceless treasures of the Prudhommescue home.

Another main division of Cham's work was his pictorial review of the Salon. Year by year he was at the opening of this great

picture show, and his verdict was awaited with more impatience than the verdicts of the critics. It was delivered in the form of an outrageous caricature of the more striking pictures. Artists highly valued a place in this collection ; it was always an extensive advertisement ; and it was sometimes a happy means of learning one's faults—but not always : for when Cham could not find a fault he would invent one. By long habit, he had become a kind of machine for making fun. His eye for the ridiculous was unailing : in the very spheres and triangles of geometry he would have seen something grotesque. He did produce a comic grammar, and he might have produced a comic Euclid. If you had shaken him out of a sound sleep and ordered jokes on any subject, he could have turned them off for you by the page. This is the journalist's faculty of readiness ; and he was the journalist or nothing. At the Salon he reveled in the enjoyment of this power. His footsteps were dogged ; artists carried round the good news that he had stopped before a comrade's work. A



M. PRUDHOMME SALUTING THE STATUE OF THE KING OF PRUSSIA.

few scratches of his unsparing pencil were fame, or an addition to fame. The only men who had a grievance against him were those he did not caricature. In Burger's charming picture of "The Bath" no one would think there was much to laugh at. This very accurate drawing of a female figure standing for refreshment in the spray of a fountain might almost be offered as a prize puzzle question for the ridiculous. Given these

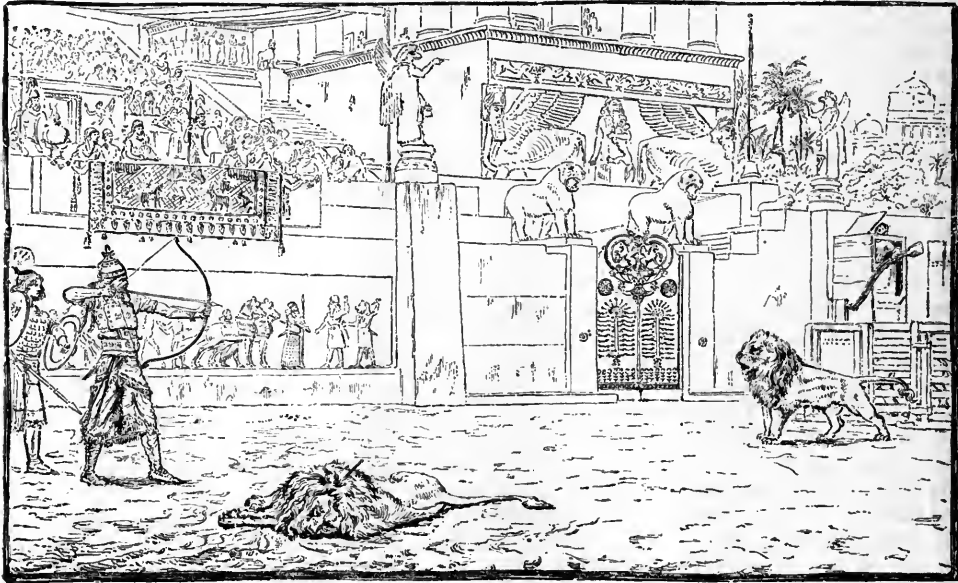

MEMORANDUM SKETCH OF BRIDGEMAN'S "DIVERSIONS OF AN ASSYRIAN KING."

finely flowing lines of form, this perfect modeling and grace of pose—where is the comic situation? Cham sees it by imagining that the young person is not so much in a shower-bath as in a shower, and that the sculptured dolphin which supports the basin is gallantly holding an umbrella over

that he is too stiff to have any life in him. "The lion never budes," he says, "for he is convinced that he has an affair with a *bonhomme* of wood. Gérôme exhibits "The Clothes Merchant of Cairo," one of his fine Eastern studies of costume and character. There is an incongruity in it some-

where, though we never find it out till the "Charivari" appears with Cham's hideous drawing of a Turk who buys his sabers of his tailor. Gérôme is true to Eastern manners, no doubt; but it is enough for Cham that he is false to the manners of the West. Sometimes the Salon sketches are a happy *exposé* of the weaknesses and the rancors of artists.

"Oh!" says a Bohemian of the brush, meeting another, "I want to have a talk with you."

"Come along, then, and let us stand before your picture; we shall be sure not to be disturbed."

Cham's annual Salon series was hardly finished when he had to begin to think of his almanacs. For many of these he had to do little more than make a selection from the drawings of the year. They consisted of sea-

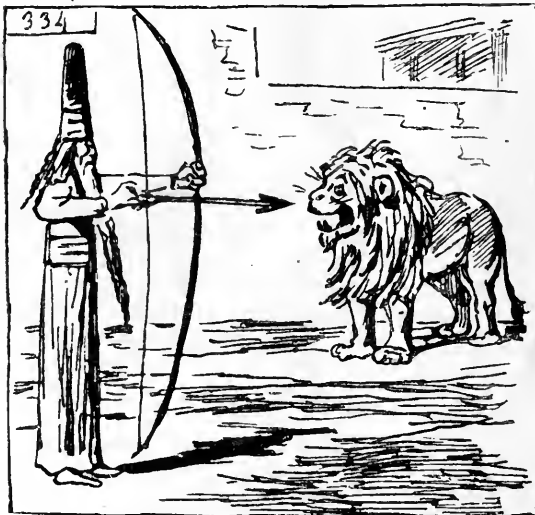

CHAM AFTER BRIDGEMAN.

sonable illustrations of every phase of Parisian life. In the January page we have the agony of New Year's presents. The very postman brings you his gift,—an almanac,—which you are expected to ac-

cept with a certain amount of resignation. The very postman brings you his gift,—an almanac,—which you are expected to ac-

knowledge with a tip. Here, perhaps, Cham may strike a new and unwonted note in his sketch of an old man,—M. Prudhomme, it may be, in his dotage,—who asks for a calendar with “longer days.” In another drawing we see the ruffian at the court of assizes, who thought he might save his skin by wishing the judge “A happy New Year.” “And he gave you nothing in return?” asks an expectant friend, who is waiting to know his fate. “Yes; five years.” In another is the *bourgeois*, who, foreseeing a host of uninteresting callers, prepares to receive them with a loaded bomb-shell on his knee. “Come in! come in!” he cries, cheerily, in answer to the first knock, “I am only just unscrewing the top of this thing; and I am so awkward, you cannot think.” For the racing season we have a thief complaining that the pockets in the new-fashioned sporting-coats are so uncommonly deep. A little later on we are at the sea-side, where a bathing-man, following the gaunt figure of a female in bathing-dress, declares in a rhapsody of delight that he will dip her for nothing, because of the memories her slender shape awakens of the herring fishery of his youth. In the shooting season we have the sports-

ways talking politics,” says one, “he must be a deputy.” “I think he is a sculptor,” says the other, “from what he said about the *statu quo*.” The brand-new Opera-House itself does not escape without a



RECOLLECTIONS OF YOUTH.

touch or two at the expense of the architect. Cham requests you to take off your shoes and stockings before mounting the magnificent staircase; and he thinks that the fountain at the bottom of it must have been built to give the flunkeys something to fish in while waiting for the conclusion of the piece.

No man made more sketches than Cham,—not even Doré, who is said to be one of the fastest workers on record. Cham drew right and left: for the “Charivari,” for the *Monde-Illustré*, for the publishers of almanacs, of albums, of toy-books,—in short, for everybody who wanted the pictorial comic man. His workshop and his home were in the rue Nollet, in the Batignolles,—not a very savory quarter, and next to the Latin Quarter, one of the most Bohemian in Paris. Here, at his standing desk he knocked off his first projects for sketches. Rough as his work looks, it was still rougher in the form in which it was first presented to his editors. If he had a dozen sketches to do, he sent in three times the number of preliminary suggestions, each no more than a few scratches marking the position of the figures, with the proposed motto scribbled in ink below. The accepted designs were afterward more carefully worked up. This is exemplified in a fac-simile of his “project of caricature” for Gérôme’s picture representing the entry of a mosque. According to custom, the shoes of the wor-



“DO YOU HUNT, TOO?”

man’s question to a mysterious stranger. “And do you hunt, too?” “Yes, sir, all the year round: I am a bailiff.” A little later on we are at the Opera ball with its throng of *débardeuses* and fogies who are seeing life. The ignorance of these young women, who are not exactly the fine flower of Parisian intelligence, sometimes leads to very clumsy guesses as to the position of their accidental acquaintance. “He is al-

shippers are left in the porch; the painter has not forgotten them; but Cham naturally chooses to believe that he has forgotten everything else. As he sees the work it is all shoes; and he hastily dashes off that idea in picture, with the legend: "M. Gérôme has not made all these things; some of them were supplied by prison labor." The rough idea for a joke on the bad quality of the government lucifer matches is in the form of a scrawl, which is understood to represent a rural gendarme, stopping another scrawl, which is supposed to represent a sportsman lighting his pipe. "I must report you," says the man of law; "you are using matches that will strike, so they must be of clandestine make."

Cham's work was very emphatically a part of his life. His invention was exercised as freely in society as in his calling. He "exhibited for nothing" to his friends, and he was one of the pleasantest dinner-party men in Paris. Nearly all his work has the character of the impromptu. He had the American gift of humorous exaggeration; he saw jokes in large, like Mark Twain. He was talking one day with a Gascon, who bragged that his father's ancient baronial dining-hall was the wonder of the world. It was so high you could hardly see the roof. "My father had a dining-room," said Cham, "which was just as remarkable the other way. It was so low that the only fish we could serve at table was sole." "It is no use

fighting duels with me," he said, in allusion to his weight and long reach, "when I make a thrust in Paris, the point of the sword



883- M. Gérôme

CHAM AFTER GÉRÔME.

goes into the provinces." He has drawn his own lanky figure in many of his books. In the latest of these sketches only the head stands out distinctly; all the rest fades away in thin, nebulous scratches, which give a good effect of indefinite length. It was only natural that he should deal out to himself the same measure as to others, for he was a chivalrous man, and he had the tenderest of hearts. He was not only kind to animals, he was almost a slave to them. His pet dog ruled the studio, and, but for the Comtesse de Noé, would have ruled the house. Cham's letter on vivisection is a humane cry of anguish from first to last, and there are passages in it worthy to form his epitaph.



MATCHES OF CLANDESTINE MAKE.

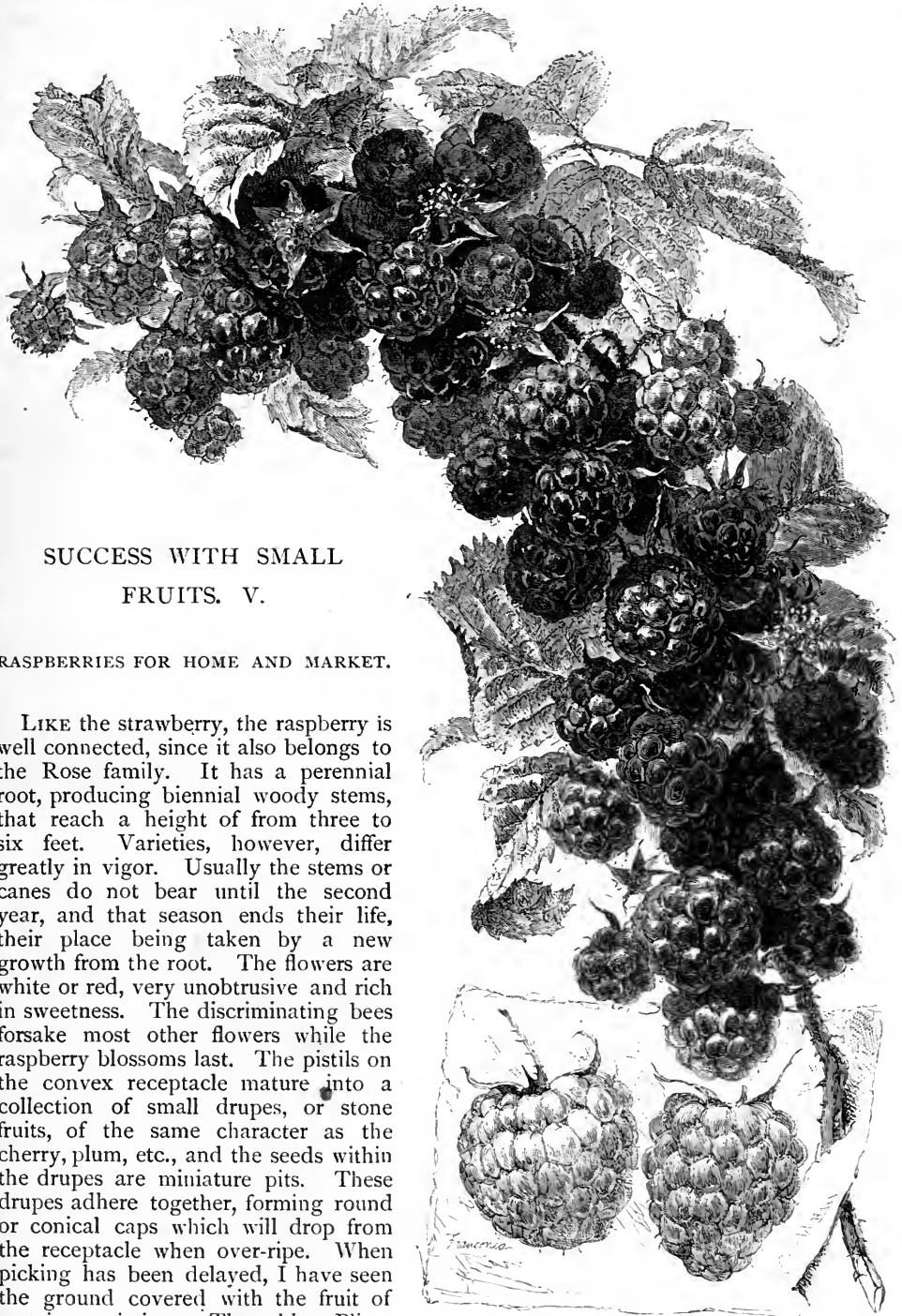

SUCCESS WITH SMALL FRUITS. V.

RASPBERRIES FOR HOME AND MARKET.

LIKE the strawberry, the raspberry is well connected, since it also belongs to the Rose family. It has a perennial root, producing biennial woody stems, that reach a height of from three to six feet. Varieties, however, differ greatly in vigor. Usually the stems or canes do not bear until the second year, and that season ends their life, their place being taken by a new growth from the root. The flowers are white or red, very unobtrusive and rich in sweetness. The discriminating bees forsake most other flowers while the raspberry blossoms last. The pistils on the convex receptacle mature into a collection of small drupes, or stone fruits, of the same character as the cherry, plum, etc., and the seeds within the drupes are miniature pits. These drupes adhere together, forming round or conical caps which will drop from the receptacle when over-ripe. When picking has been delayed, I have seen the ground covered with the fruit of certain varieties. The elder Pliny, who wrote about 45 A. D., states that

the Greeks distinguished the raspberry bramble by the term "*Idea*," and, like so many other Grecian ideas, it has found increasing favor ever since. Mr. A. S. Fuller, one of the best-read authorities on these subjects, writes that "Paladius, a Roman agricultural author, who flourished in the fourth century, mentions the raspberry as one of the cultivated fruits of his time." It thus appears that it was promoted to the garden long before the strawberry.

While it is true that the raspberry in various forms is found wild throughout the continent, and that the ancient gardeners in most instances obtained their supply of plants in the adjacent fields or forests, Mr. Charles Downing is of the opinion that the large-fruited foreign varieties are descendants of the "Mount Ida bramble," and from that locality they were introduced into the gardens of Southern Europe.

In America, two well-known and distinct species are enriching our gardens and gracing our tables with their healthful fruit. We will first name *Rubus Strigosus*, or the wild red raspberry, almost as dear to our memory as the wild strawberry. It grows best along the edge of woodlands and in half-shadowy places along the roadside.

Professor Gray thus describes this species:

"*R. STRIGOSUS*, Wild Red R. Common, especially North; from two to three feet high; the upright stems, stalks, etc., beset with copious bristles, and some of them becoming weak prickles, also glandular; leaflets oblong-ovate, pointed, cuteserrate, white-downy beneath, the lateral ones (either one or two pairs) not stalked; petals as long as the sepals; fruit light-red, tender and watery, but high flavored, ripening all summer."

The second great American species, *Rubus Occidentalis*, will be described hereafter. Since these papers are not designed to teach botany, I shall not refer in these papers to other species which are of no practical value, and, for the present, will confine myself to the propagation and cultivation of *R. Ideus* and *R. Strigosus* and their seedlings, ending with a description of the different varieties.

PROPAGATION.

VARIETIES of these two species usually throw up suckers from the roots in sufficient abundance for all practical purposes, and

these young canes from between the hills or rows are, in most instances, the plants of commerce and the means of extending our plantations. But where a variety is scarce, or the purpose is to increase it rapidly, we can dig out the many interlacing roots that fill the soil between the hills, cut them into two-inch pieces, and each will develop within a year into a good plant. Fall is the best season for making root cuttings, and it can be continued as late as the frost permits. My method is to store the roots in a cellar and cut them from time to time, after out-of-door work is over. I have holes bored in the bottom of a box to ensure drainage, spread over it two inches of moist (not wet) earth, then an inch layer of the root cuttings, a thin layer of earth again, then cuttings until the box is full. If the cellar is cool and free from frost, the cuttings may be kept there until spring; or the boxes containing them can be buried so deeply on a dry knoll in the garden as to be below frost. Leaves piled above them ensure safety. Make sure that the boxes are buried where no water can collect either on or beneath the surface. Before new roots can be made by a cutting, a whitish excrescence appears at both its ends, called the callus, and from this the rootlets start out. This essential process goes on throughout the winter, and hence the advantage of making cuttings in the fall. Occasionally, when purchasing a variety that we are anxious to increase, some of the roots may be taken off for cuttings before setting out the plants.

These little root-slips may be sown, as one would sow beans, early in the spring, as soon as the ground is dry enough to work. A plot of rich, moist land should be chosen, and the soil made mellow and fine as if for seed; drills should then be opened eighteen inches apart, two inches deep on heavy and three inches deep on light land. The cuttings must now be dropped three inches from each other in the little furrows, the ground leveled over them and firmed, which is done best by walking on a board laid on the covered drill. If the entire cutting-bed were well sprinkled with fine compost, and then covered with a mulch of straw so lightly—to the depth of an inch or two—that the shoots could come through it without hindrance, scarcely a cutting would fail. Unfailing moisture, without wetness, is what a cutting requires.

If forced under glass, roots may be divided into half-inch bits, and in this way nur-

serymen often speedily provide themselves with large stocks of very scarce varieties. The cuttings are placed in boxes of sand until the callus forms and little buds appear on the surface of the roots, for which processes about five weeks are required. They are then sown in shallow boxes containing about three inches of soil formed of equal parts of sand and decayed leaves, and subjected to the heat of the green-house. When they have formed plants from three to five inches high they may be potted, if very valuable, or, if the weather is warm enough, they can be transplanted at once into the open nursery-bed, as one would a strawberry-plant. I have set out many thousands in this way, only aiming to keep a little earth clinging to the roots as I took them from the shallow box. Plants grown from cuttings are usually regarded as the best, but if a sucker plant is taken up with fibrous roots I should regard it as equally good.

CHOICE OF LAND. ITS PREPARATION. PLANTING.

ALL that has been said about the thorough preparation of the soil for strawberries by drainage, deep plowing, trenching, etc., applies to raspberries, but differences should be noted in respect to fertilizers. Land can scarcely be made too rich for any variety of strawberries, but certain strong-growing raspberries, as the Cuthbert, Herstine, and Turner, should not be over-fertilized. Some kinds demand good, clean culture, rather than a richness that would cause too great a growth of cane and foliage. In contrast the more feebly growing kinds, as the Brandywine, and most of the foreign varieties, require abundance of manure. Muck sweetened by lime and frost, is one of the simplest and best, but anything will answer that is not too full of heat and ferment. Like the strawberry, the raspberry needs cool manures that have "staying" qualities. Unlike the former fruit, however, the raspberry does well in partial shade, such as that furnished by the northern side of a fence, hedge, etc., by a pear or even apple orchard, if the trees still permit wide intervals of open sky. The red varieties, especially those of the foreign type, much prefer moist, heavy soils, but the blackcaps do quite as well on light ground if moisture can be maintained. The latter also can be grown farther south

than any other species, but below the latitude of New York, those containing foreign elements begin to fail rapidly, until, at last, a point is reached where even the most vigorous native red varieties refuse to live. If the climate, however, is tempered by height above the sea, as in the mountains of Georgia, they will thrive abundantly.

I prefer fall planting for raspberries, especially in southern latitudes, for these reasons: At the points where the roots branch are buds which make the future stems or canes. In the fall these are dormant, small, and not easily broken off (see fig. B); but they start early in spring, and, if planting is delayed, these become so long and brittle (fig. A) that the utmost care can scarcely save them. If rubbed off, the development of good bearing canes is often deferred a year, although the plants may live and fill the ground with roots. My custom is to plant the latter part of October and through November, in well prepared and enriched land. The holes are made quite deep and large, and the bottom filled with good surface soil. If set immediately on a hard subsoil, plants will suffer from every drouth. On heavy land I set the plants one or two inches deeper than they were before; on



SPRING AND FALL PLANTS.

light soils three inches deeper. I cut the canes off six inches above the surface (see fig. C), for leaving long canes is often ruinous, and a plant is frequently two or three years in recovering from the strain of trying to produce fruit the first year. The whole strength of the roots should go toward pro-

ducing bearing canes for the season following, and to stimulate such growth, I throw directly on the hill one or two shovelfuls

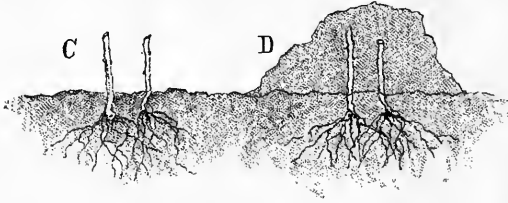

WINTER PROTECTION OF NEWLY SET PLANTS.

of finely rotted compost, and then mound the earth over the hill until the cane is wholly covered, as in Fig. D. This prevents all injury from the winter's cold. When severe frosts are over, the mound is leveled down again. Under this system I have rarely lost a plant, and usually find that double growth is made compared with those set *late* in spring. I have always succeeded well, however, in *early* spring planting, and well to the north this is perhaps the safer season. With the exception of mounding the earth over the hill, one may plant in March or April as I have already directed.

CULTIVATION.

IN cultivation keep the ground level—do not let it become banked up against the hills, as is often the case, especially with those tender varieties that are covered with earth every winter. Keep the surface clean and mellow by the use of cultivator and hoe, and occasionally loosen the soil deeply by running the subsoil plow between the rows. This enables the roots to go beneath the strata affected by temporary drouth—that chief enemy of American fruit culture. With the exception of from four to six canes in the hill, treat all suckers as weeds, cutting them down while they are little—before they have sucked half the life out of the bearing hill. Put a shovelful or two of good compost—any fertilizer is better than none—around the hills or along the rows late in the fall, and work it lightly in with a fork if there is time. The autumn and winter rains will carry it down to the roots, giving almost double vigor and fruitfulness the following season. If this top-dressing is neglected in the autumn, be sure to give it as early in spring as possible, and work it down toward the roots. Bone-dust, ashes, poudrette, barn-yard manure, and muck with lime can be used alternate years,

so as to give variety of plant food, and a plantation thus sustained can be kept twenty years or more, but under the usual culture, vigor begins to fail after the eighth or tenth season. The first tendency of newly set red raspberries is to sucker immoderately, but this gradually declines even with the most rampant, and under good culture the fruiting qualities improve.

PRUNING. STAKING. MULCHING.

USUALLY there is no other pruning either in the field or the garden beyond the cutting out of the old canes, and the shortening in of the new growth. There is a difference of opinion as to whether the old canes should be cut out immediately after fruiting, or left to natural decay and removed the following fall or spring. I prefer the former course. It certainly is neater, and I think I have seen increased growth in the young canes for which more room is made and to whose support the roots can give their whole strength. This new growth can make foliage fast enough to develop the roots; still, I have not experimented carefully, and so cannot speak accurately. We often see summer pruning advocated on paper, but I have rarely met it in practice. If carefully done at the proper season, however, much can be accomplished by it in the way of making strong, stocky plants, capable of standing alone—plants full of lateral branches, like little trees likely to be loaded with fruit. But this summer pinching back must be begun early, while the new succulent growth is under full headway and continued through the busiest season, when strawberries are ripe and harvest is beginning. It should not be done after the cane has practically made its growth, or else the buds that ought to remain dormant until the following season, are started into a late and feeble growth that does not ripen before the advent of early frosts. Few have time for pruning in May and June. If they have, let them try it by all means, especially on the blackcap species. The best I can do is to prune in November and March—it should be done before the buds develop. Unless early fruit is wanted, I believe in cutting back heroically. Nature once gave me a very useful hint. One very cold winter a row of Clarke raspberries were left unprotected. The canes were four and five feet high, but were killed down to the snow-level, or within eighteen inches of the

ground, and from the short, uninjured parts we had as many and far finer berries than were gathered from other rows where the canes had been left their full length and protected by a covering of earth. The fruit was later, however. I would remind careful observers of the raspberry how often buds on canes that have been broken off or cut way back develop into long sprays, enormously fruitful of the largest berries. I have counted fifty, or even eighty, berries on a branch that had grown from a single bud within one or two feet of the ground. These lower buds often do not start at all when the canes are left their full, or nearly their full length. In the latter case the fruit ripens much earlier and more together, and since an early crop, though inferior in quality and quantity, may be more valuable than a late one, the fruit-grower often objects to pruning. But in the garden, while the canes of some early kinds are left their full length, I would recommend that others, especially those of the later varieties, be cut back one-half. Even for market purposes, I believe that the superb fruit resulting from such pruning would bring more money in most instances. At any rate, the season of bearing would be greatly prolonged.

In most localities mulching on a large scale would not pay. In regions where salt hay, flags, etc., can be cut in abundance, or when straw is so plenty as to be of little value, it no doubt could be applied profitably. On Staten Island I have seen large patches mulched with salt hay. The canes were unstaked and many of them bent over on the clean hay with their burden of fruit. When there are no stakes or other supports used, the berries certainly should be kept from contact with the soil. The chief advantage of the mulch, however, is in the preservation of moisture. When it is given freely, all the fruit perfects itself and in a much longer succession. The weeds and suckers are kept down, and the patch has a neat appearance. Moreover, mulching prevents the foliage from burning, and enables the gardener to grow successfully the finer varieties farther to the south and on light soils. In keeping down the weeds through the long summer, a mulch of leaves, straw, or any coarse litter, is often far less costly than would be the labor required. In dry weather, the fork should not be used during the growing or bearing season. The turning down of a strata of dry, hot soil next to the roots must cause a sudden check and injury from which only a soaking rain can

bring full relief. But in moist weather I have often used the fork to advantage in the garden, especially if there has been a sod of short succulent weeds to be turned under as a green crop. If the ground between the hills were often stirred thoroughly with an iron garden-rake, the weeds would not have a chance to start. This is by far the best and cheapest way of maintaining our unceasing conflict with vegetable evil. An Irish bull hits the truth exactly—the best way to fight weeds is to have none to fight, and raking the ground over on a sunny day about once a week destroys them when they are as yet but germinating seeds. At the same time it opens the pores of the earth, as a physiologist might express it. Unfailing moisture is maintained, air, light and heat are introduced to the roots in accordance with Nature's taste, and the whole strength of the mellow soil goes to produce only that which is useful.

Staking raspberries is undoubtedly the best, simplest and cheapest method of supporting the canes of most varieties and in most localities. I agree with the view taken by Mr. A. S. Fuller. "Chestnut stakes," he writes, "five feet long and two or three inches in diameter, made from large trees, cost me less than two cents each, and my location is within twenty miles of New York City, where timber of all kinds commands a large price. I cannot afford to grow raspberries without staking, because every stake will save on an average ten cents' worth of fruit, and, in many instances, three times that amount." Of course, split chestnut stakes look the neatest and last the longest, but a raspberry bush is not fastidi-

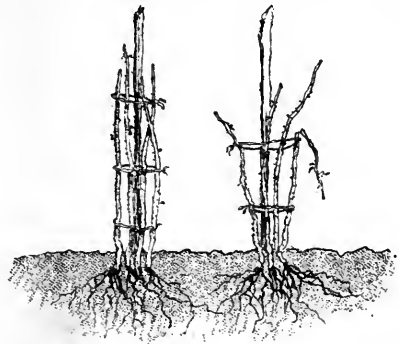

a, Canes snugly tied. b, Canes improperly tied.
RIGHT AND WRONG WAYS OF TYING CANES.

ous, and I utilize old bean poles, limbs of trees—anything that keeps the canes from sprawling in the dirt with their delicate

fruit. Thus, in many instances, the stakes will cost little more than a boy's labor in preparing them, and they can be of various lengths according to the height of our canes. As they become too rotten for further use,

course. The canes should be snugly tied their whole length.

WINTER PROTECTION—TAKING UP PLANTS
—STORING THEM FOR SPRING USE.

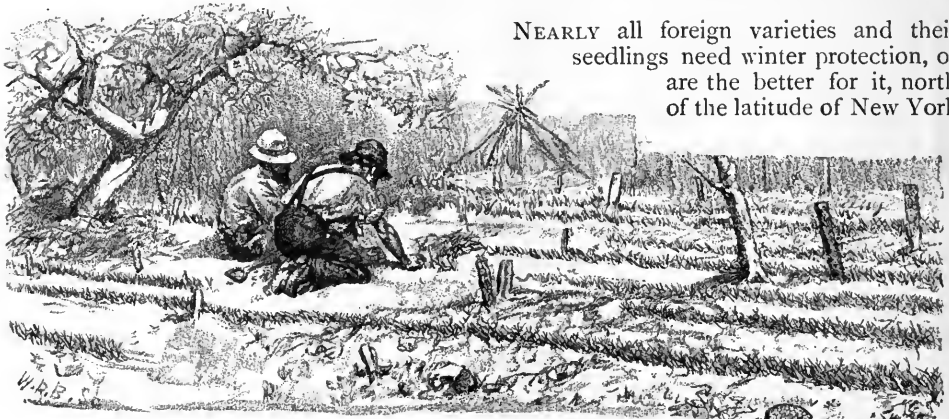

STORAGE GROUND.

they make a cheery blaze on the hearth during the early autumn evenings.

In many localities, however, stakes are dispensed with, and by cutting the canes back they are made in a measure self-supporting, or else mulch is placed beneath them to keep the fruit clean. In the garden, also, wires fastened to stout stakes are occasionally stretched along the rows, and the canes tied to these. The method in this section, however, is to insert stakes firmly in the hill by means of a crowbar, and to tie the canes to them as early in spring as possible.

Unless watched, the boys who do the tying persist in leaving the upper cords of the canes loose. These unsupported ends, when weighted with fruit and foliage, break, of

City. Many of the hardier kinds, like the Herstine and

Clarke, will usually survive if bent over and kept close to the earth by the weight of poles or a shovelful or two of earth, and, if covered with snow merely, will often endure the steady cold of the North far better than the alterations of temperature in the Middle States. All of the Antwerp class need to be entirely covered.

To many this winter covering is a great bugbear, even when only a small patch in the garden is involved. There is a constant demand for "perfectly hardy" varieties. It should be remembered that many of the best kinds are not hardy at all, and that perhaps none are "perfectly hardy." The Turner has never been injured on my place, and the Cuthbert is rarely hurt; but occasionally they are partially killed. What are termed "open winters" are often the most

destructive. I find that it pays to cover all those kinds that are liable to injury, and as the varieties are described this need will be distinctly stated. The difficulties of covering are chiefly imaginary, and it can be done by the acre at comparatively slight

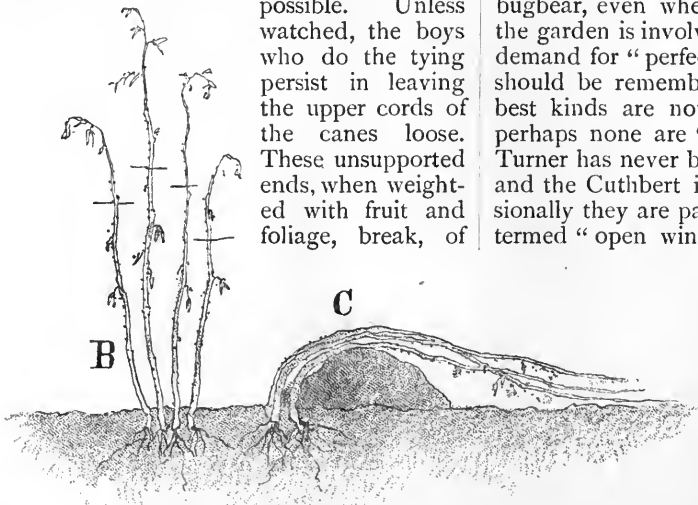

PRUNING AND LAYING DOWN CANES.

cost. The vast crops of the Hudson River Antwerp were raised from fields covered every fall. In the garden I do not consider the labor worth naming in comparison with the advantages secured. Those who find time to cover their cabbages and gather their turnips, should not talk of the trouble of protecting a row of delicious Herstine raspberries. Still, Nature is very indulgent to the lazy, and has given us a raspberry as fine as the Cuthbert that, thus far, with but few exceptions, has endured our Northern winters. In November I have the labor of covering performed in the following simple way: B is a hill with canes untrimmed, with marks indicating that they should be shortened one-third—my rule in pruning. After trimming, the canes are ready to be laid down, and they should all be bent one way. To turn them *sharply* over and cover them with earth, would cause many of the stronger ones to break just above the root, so I have a shovelful of soil thrown on one side of the hill, as in Fig. C, and the canes bent over this little mound. They thus describe a curve, instead of lying at right angles on the surface with a weight of earth upon them. A boy holds the canes down while a man on either side of the row rapidly shovels the earth upon them. If the work is to be done on a large scale, one or two shovelfuls will pin the canes to the earth, and then, by throwing a furrow over them on both sides with a plow, the labor is soon accomplished. It will be necessary to follow the plow with a shovel and increase the covering here and there. In spring, as soon as hard frosts are over—the first week in April in our latitude, usually—begin at the end of the row toward which the canes were bent, and with a fork throw and push the earth aside and gently lift the canes out of the soil, taking pains to level the ground thoroughly, and not leave it heaped up against the hills. This should not be done when the earth is wet and sticky. At such times keep off the ground, unless the season is growing so late that there is danger of the canes decaying, if not exposed to the air. The sooner they are staked and tied up after uncovering the better.

For market or other purposes we may wish a number of young plants, in which case there is much room for good sense in taking them up. Many lay hold upon the canes and pull so hastily that little save sticks come out. A gardener wants fibrous roots rather than top; therefore send the spade down under the roots and pry them out. Suckers

or root-cutting plants can be dug in October after the wood has fairly ripened, but be careful to leave no leaves on the canes that are dug before the foliage falls, as they rapidly drain the vitality of the plants. It is best to cut the canes down to within a foot of the surface before digging. I prefer taking up all plants for sale or use in November, and those not set out or disposed of are stored closely in trenches, with the roots a foot or more below the surface. By thus burying them deeply and by leaving on them a heavy covering of leaves, they are kept in a dormant state quite late in spring, and so can be handled without breaking off the buds which make the future canes. But, as we have already said, the earlier they are planted after the frost is out, the better.

We may now give our attention to

VARIETIES AND THEIR DISTINGUISHING CHARACTERISTICS.

As was true of strawberries, so, also, varieties of raspberries that won name and fame abroad were imported, and a few of them have adapted themselves so well to American soil and climate that they have become standards of excellence. Among the earliest known of these was the Red Antwerp of England. At one time few old-fashioned gardens were without it, but it is fast giving way to newer and more popular varieties. The canes are vigorous, stocky and tall; spines light-red, numerous, and rather strong. Winter protection is always needed. The berries are large and very obtuse conical, dark-red, large-grained and covered with a thick bloom, very juicy and exceedingly soft—too much so for market purposes. They make a dainty dish for home use, however.

The Hudson River Antwerp, the most celebrated foreign berry in America, is quite distinct from the above, although belonging to the same family. It is shorter and more slender in its growth, quite free from spines, and its canes are of a peculiar mouse-color. Its fruit is even larger, but firm, decidedly conical, not very bright when fully ripe, and rather dry, but sweet and agreeable in flavor. Mr. Downing says that its origin is unknown, and that it was brought to this country by the late Mr. Briggs, of Poughkeepsie, N. Y. Mr. Fuller adds that it was supposed to have been procured in England, while its name suggests Belgium as its original home. It continues long in bearing, and the berries

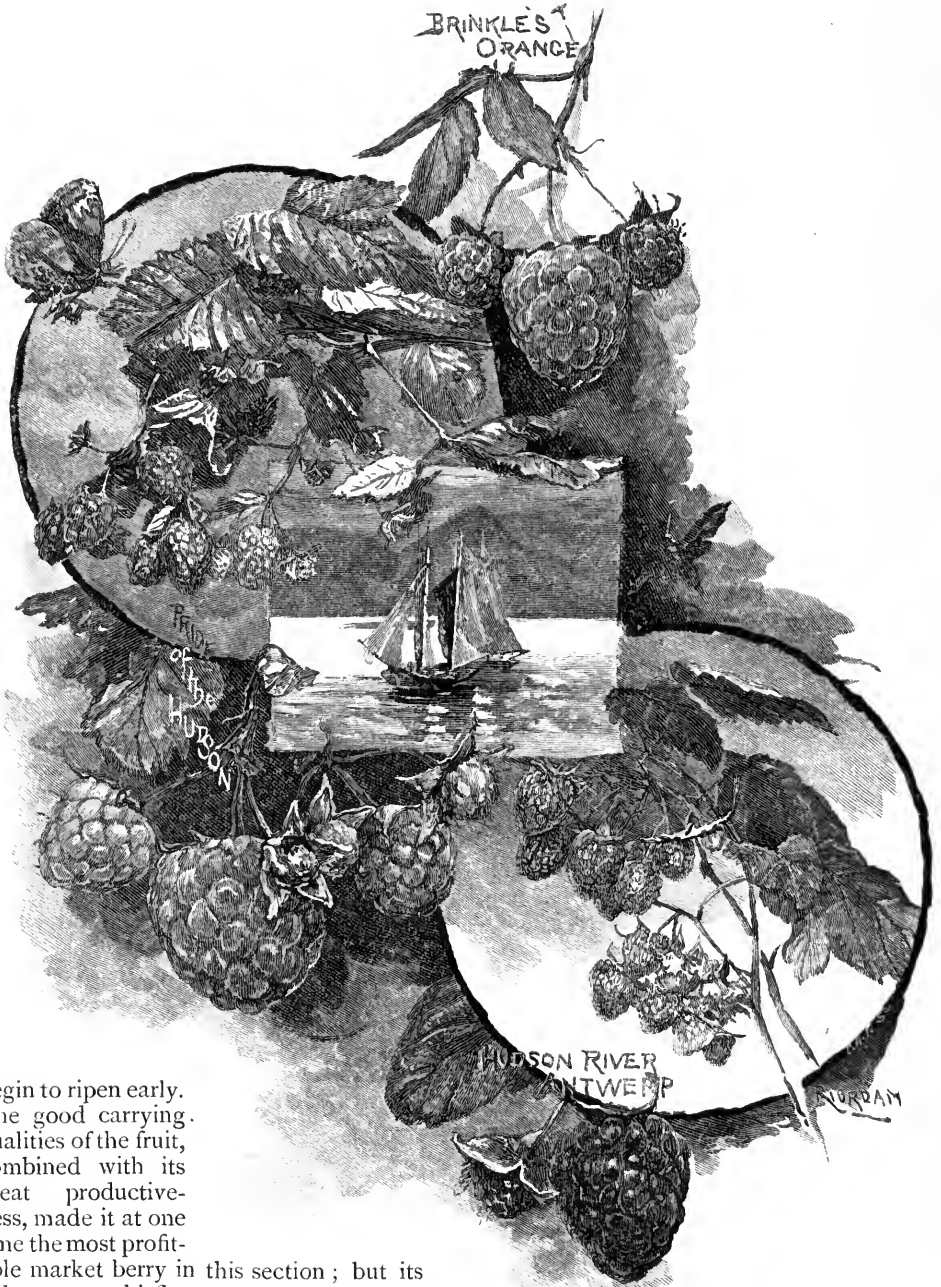

begin to ripen early. The good carrying qualities of the fruit, combined with its great productiveness, made it at one time the most profitable market berry in this section ; but its culture was chiefly confined to a narrow strip on the west shore of the Hudson, extending from Cornwall to Kingston. For some obscure reasons, it did not thrive in other localities, and now it appears to be failing fast in its favorite haunt. A disease called the curl-leaf is destroying some of the oldest and largest plantations, and the growers are looking



ANTWERP CLASS OF RASPBERRIES.



THE RUSH FOR THE NIGHT BOAT.

around for hardier and more vigorous varieties. But in its palmy days, and even still, the Hudson River Antwerp was one of the great productions of the country, and the barges and steamers to New York were nightly laden with ruby cones, whose aroma was often very distinct on the lee shore while the boats were passing. The enormous business also had in part a chance and curious origin. The Antwerp of the west shore may be traced back through two lines of ancestry. The first plants ever grown in that region were brought to Milton from Westchester, N. Y., by Mr. Nathaniel Hallock. I am indebted for the following facts to Mr. W. C. Young, of Marlboro', N. Y.:

About forty-five years ago a bundle of raspberry plants was left at a meat-market in Poughkeepsie, and Mr. Watters, the proprietor of the place, kept them several days, expecting that they would be called for. As they remained upon his hands he planted them in his garden, where, like genuine worth, they soon asserted their superiority. Mr. Edward Young, of Marlboro', a relative of Mr. Watters, received a present of a few roots, which supplied his family with the largest and most beautiful berries he had ever seen. Mr. Young soon had far more fruit than was needed by his family, and he resolved to try the fortunes of his favorite in the New York market. "For this purpose," his son writes, "my father procured imported fancy willow baskets,

holding about one pint each, and carefully packed these in crates made for the purpose. This mode proved a success, both in carrying them securely and in making them very attractive. The putting up such a fine variety of fruit in this way gave it notoriety at once, and it brought at first as much as one dollar per quart. My father was so well satisfied with his experiment that he advised his sons, Alexander, Edward and myself, to extend the culture of this variety largely. We entered into the business, and, pursuing it with diligence, were well compensated. Our success made others desirous of engaging in it, and so it spread out into its large dimensions." Mr. Taber's graphic picture of "The Rush for the Night-boat" suggests how extensive that business became. The line of wagons at Marlboro' Landing was often nearly half a mile long. Mr.

Alex. Young estimates that in the year 1858 1,000,000 pint baskets, or about 14,700 bushels, were shipped from Marlboro'; but adds that since 1860 "it has decreased as fast. From present appearances, the variety must become extinct, and I fear will never have its equal." Milton, Cornwall, Newburgh, and other points competed in the profitable industry, and now, with Marlboro', are replacing the failing variety with other kinds more vigorous in growth, but thus far inferior in quality. That the great industry is not falling off is shown by the following statement in the New York "Tribune" last summer:

Boston, about thirty-seven years ago, and is a large obtuse conical berry; it is firm, thus carrying well to market, and although a little sour, its acid is of a rich and sprightly character. It is raised largely in Western New York, and in northern latitudes is one of the most profitable. One of its best qualities is its long continuance in bearing; we usually enjoy them for six weeks together. Its almost globular shape is in contrast with another most excellent French variety, the Belle de Fontenay, a large, long, conical, but somewhat irregular-shaped berry of very superior flavor. It is much hardier than most of the foreign kinds, and on my



THE APPROACH OF THE NIGHT BOAT.

"The village of Highland, opposite Poughkeepsie, runs a berry boat daily to New York, and the large night steamers are now taking out immense loads of raspberries from the river towns every evening, having at times nearly 2,000 bushels on board."

The Fastolf, Northumberland Fillbasket, and Knevet's Giant, are fine old English varieties that are found in a few private gardens, but have never made their way into general favor.

The Franconia (see page 753) is now the best foreign variety we have. It was introduced from Paris by Mr. S. G. Perkins, of

grounds survives ordinary winters without protection. The canes are very stocky and strong, and unless growing thickly together, are branching. Its most marked characteristics, however, are its tendencies to sucker immoderately and to bear a second crop in autumn, produced on the tips of the new canes. If the canes of the previous year are cut even with the ground early in spring, the new growth gives a very abundant autumn crop of berries, which, although much inclined to crumble in picking, and to be irregular in shape, have still the rare flavor of a delicious fruit long out of season. It certainly is the best of the fall-bearing

kinds, and deserves a place in every garden. There are more profitable market varieties, however. Its autumn fruitfulness is shown by the engraving (p. 753) of a loaded tip, cut in October, and the late berries are seen to be very different in shape from the one that is the type of those that mature in July.

The Belle de Pallua and Hornet are also French varieties, that in some sections yield fine fruit, but are too unreliable to become favorites in our country.

I have a few canes of a French variety, of which Mr. Downing imported a number years since, and of which the name has been lost. It certainly is the finest raspberry I have ever seen, and I am testing its adaptation to various soils.

Having named the best-known foreign varieties, I will now turn to *R. Strigosus* or our native species, which is scattered almost everywhere throughout the North. In its favorite haunts by hedge, roadside and forest edge, a bush is occasionally found producing such fine fruit that the delighted discoverer marks it, and in the autumn transfers it to his garden. As a result a new variety is often heralded throughout the land. A few of these wildings have become widely popular, and among them the Brandywine probably has had the most noted career.

Mr. William Parry, of New Jersey, who has been largely interested in this variety, writes: "I have never been able to trace the origin of this berry. It attracted attention some eight or ten years since in the Wilmington market, and was for a time called the 'Wilmington.'" Subsequently Mr. Edward Tatnall of that city undertook to introduce it by the name of Susqueco, the Indian name for the Brandywine. It soon became the principal raspberry grown along the Brandywine Creek, and as the market-men would persist in calling it after its chief haunt, it will probably bear the historical name until it passes wholly out of favor. Its popularity is already on the wane, because of its dry texture and insipid flavor, but its bright color, good size, and especially its firmness and remarkable carrying qualities, will ever lead to its ready sale in the market. It is not a tall, vigorous grower except in very rich land. The young canes are usually small, slender, of a pale red color, and having but few spines. Like nearly all of the *R. Strigosus* species, it tends to sucker immoderately. If this disposition is rigorously checked by hoe and cultivator it is productive; otherwise

the bearing canes are choked and rendered comparatively unfruitful. This variety is waning before the Cuthbert—a larger and much better berry.

The Turner is another of this class, and in Mr. Charles Downing's opinion, the best. It was introduced by Professor J. B. Turner, of Illinois, and is a great favorite in many parts of the West. It has behaved well on my place for several years, and I am steadily increasing my stock of it. I regard it as the hardiest raspberry in cultivation; a winter must be severe, indeed, that injures it. Like the Crescent Seedling strawberry, it will grow anywhere, and under almost any conditions. The laziest man on the continent can have its fruit in abundance, if he can muster sufficient spirit to put out a few roots, and hoe out all the suckers except five or six in the hill. It is early, and in flavor surpasses all of its class; the fruit is only moderately firm. Plant a few in some out-of-the-way place, and it will give a larger return for the least amount of labor than any other kind with which I am acquainted. The canes are very vigorous, of a golden reddish brown-like mahogany, over which spreads in many places a purple bloom, like that on a grape, and which rubs off to the touch. It is almost free from spines, and so closely resembles the Southern Thornless in all respects that I cannot distinguish them.

The Turner is a fine example of the result of persistent well-doing. After having been treated slightly and written down at the East for ten years or more, it is now steadily winning its way toward the front rank. Mr. A. S. Fuller, who has tried nearly all of the older varieties, says that he keeps a patch of it for his own use, because it gives so much and such good fruit with so little trouble. I find in an old number of the "Prairie Farmer" the following history, given to the writer (as it is claimed) by Professor Turner, upon whose grounds it originated:

"About thirty-five years ago the seed of the red Antwerp was sown close to his house in the hopes of getting a berry that would stand the intense cold of our winters better than the Antwerp. The product of this sowing was not such as to satisfy him, and the ground where the canes stood being required for other purposes, they were transplanted into a hedge in the remote part of the garden, where they remained unnoticed until brought to light by the professor seeing some splendid berries in the hands of his children, some ten years after the setting the canes in the hedge. On examination he concluded that they were produced by a seedling from those he had experimented upon."



NATIVE RASPBERRIES OF AMERICA. (RUBUS STRIGOSUS.)

I must differ from the professor in this conclusion, for I can see no trace of Antwerp characteristics in the Turner. The hardest raspberry we have would not come even remotely from one of the most tender.

After all, its relation to the Antwerp is only conjecture, and in the plant and fruit itself we detect only the best elements of our native species. In this opinion I am confirmed by Mr. Charles Downing; and Mr. A. S. Fuller writes me: "The Turner is a true native, *R. Strigosus*." In connection he adds the following truth, which opens to the amateur a very interesting field for experiment. "If there is any doubt in regard to such matters, raise a few seedlings of the variety, and if it is a cross or hybrid, a part of the seedlings will revert back to each parent, or so near them that there will be no difficulty in determining that there was a mixture of blood. If all our so-called hybrid fruits were so tested we would then know more of their true parentage." In

the sunny laboratory of the garden, therefore, Nature's chemistry will resolve these juicy compounds back into their original constituents. I believe the Turner to be a chance seedling, with which the professor's children have enriched the fruit world.

The Highland Hardy, or Native, also belongs to this species, and is quite a favorite still in some localities; but it has had its day, I think. Its extreme earliness has made it profitable in some regions; but its softness, small size and wretched flavor should banish it from cultivation as soon as possible.

There are others, like the Thwack, Pearl and Bristol; but they are but second-rate, being inferior in most regions to the Brandywine, which they resemble.

In my opinion, the chief value of the *R. Strigosus* is to be found in two facts. In the first place, it endures the severe

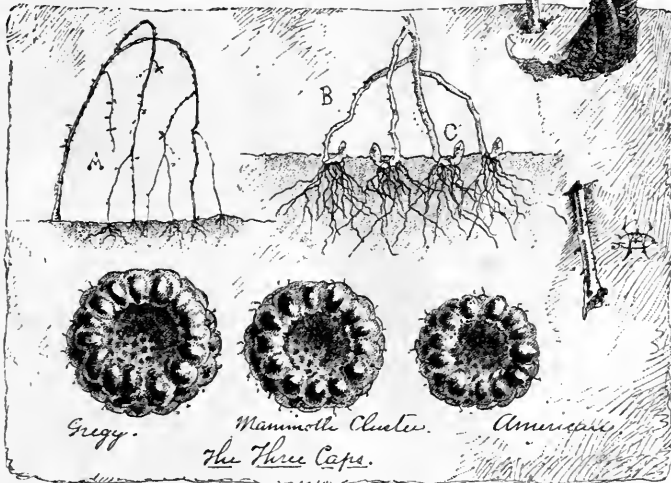

NATIVE RASPBERRIES OF AMERICA. (*RUBUS OCCIDENTALIS*.)

northern winters, and—what is of far more consequence—it thrives on light soils and its tough foliage does not burn under the hot sun. It thus becomes the one species of red raspberry that can be raised successfully in the South.

We now turn to the other great American species—*Rubus Occidentalis*, the well-known blackcap, a thimble berry that is found

along almost every roadside and fence in the land. It is scarcely necessary to recall its long, rambling, purple shoots, its light-green foliage, silvery on the under side, its sharp and abundant spines, from which we have received many a vicious scratch. Its cultivation is so simple that it may be suggested in a few sentences. It does not produce suckers, like *R. Strigosus*, but the

tips of the drooping branches (A, p. 765) root themselves in the soil during August and September, forming young plants. These, planted, produce a vigorous bush the first year and bear the second season, then die down to the perennial root, as is the case with all raspberries. Usually the tips of the *young* canes will take root, if left to themselves, unless whipped about by the wind. If new plants in abundance are desired, it is best to assist nature, however, by placing a little earth on the tip just after it begins to enlarge slightly, for it thus shows that it is ready to fulfill the great law of propagation. This labor is quickly performed by throwing a handful or two of earth on the tips with a trowel. Sometimes, after the first tip is rooted, buds a little above it will push into shoots which also will root themselves with a little assistance, as in B, and thus the number of new plants is greatly increased. At the North, spring is by far the best time for planting these rooted tips; but it should be done as early as possible, before the bud (C) has started into its brittle, succulent growth. At the South, November is probably the best season for planting. The species is one that adapts itself to most soils and endures much neglect. At the same time, it responds generously to good culture and rigorous pruning, and if moisture is abundant, the yield is simply enormous.

The varieties of this species are almost innumerable, since seedlings come up by the million every year; but the differences between the majority of them are usually very slight. There are four kinds, however, that have won honorable distinction and just popularity. The earliest of these is Davidson's Thornless, said to have originated in the garden of Mrs. Mercy Davidson, Towanda, Erie Co., N. Y. It is by no means so vigorous a grower as the other three varieties; but the sweetness of the fruit and the freedom from thorns make it desirable for the home garden. Unless high culture or moist soil is given, I do not recommend it for market.

Next in order of ripening is the Doolittle, or American Improved, introduced by Leander Joslyn, of Phelps, Ontario Co., N. Y. This hitherto has been the most popular of all the species, and thousands of bushels are annually raised for market. The plant is exceedingly vigorous, producing strong, branching canes that literally cover themselves with fruit. I have seen long rows fairly black with caps. Perhaps it should be stated that the thorns are vigorous, also.

Latest in ripening is the Mammoth Clus-

ter, or McCormick, which thus far has been my favorite. It is even more vigorous than the preceding, but not so briery or branching. The berries are produced usually in a thick cluster or bunch at the end of the branch, and they ripen more together than the other kinds. The caps, too, are much larger, more juicy and of finer flavor. One is less sensible of the seeds. Between the thumb and finger you can often gather a handful from a single spray, it is so prodigiously productive.

Thus far the McCormick has been unsurpassed, either for home use or market; but now it is encountering a rival in the Gregg raspberry, a new variety that is attracting much attention. Its history, as far as I have been able to learn it, is as follows: Some years ago Mr. Henry Barricklow, who resided in Ohio Co., Indiana, found on his premises a group of wild bushes that produced large, fine-flavored berries. His niece, Miss Gregg, transferred a few of these bushes to his garden, where they were cultivated and increased until Mr. Barricklow had several acres of the chance seedling. The berries always commanded the highest price in the local markets, because of the great size and excellent quality of the fruit; but the variety was not brought properly before the public until 1876. Then the brothers of Miss Gregg entered it for competition at the great Centennial Exhibition at Philadelphia, and under the name of "Gregg" it was awarded "the very highest premium for raspberries." Soon after, it received a flattering notice from the discriminating editor of the "Country Gentleman," and Mr. Thomas Meehan, editor of the "Gardener's Monthly," who is well known to be exceedingly careful and conscientious in endorsing new fruits, writes: "We believe this variety is generally larger than any other of its kind yet known."

Quite a distinct branch of the *R. Occidentalis* is the Purple Cane family,—so named, I think, from the purple cane raspberry that was so well known in old gardens a few years since, but which has been superseded by better kinds and is now fast passing out of cultivation. Its canes were smooth and its fruit of a dusky-red color. In other respects it resembles the blackcap tribe.

The Catawissa, found growing in a Pennsylvania grave-yard, is another berry of this class, which produces a second crop in autumn. It is tender in the Northern States and has never become popular.

The Philadelphia is the best known of

the class, and at one time was extremely popular. Its canes are smooth, stout, erect in growth, and enormously productive of medium sized, round, dusky red berries of very poor flavor. It thrives so well on the light soils about Philadelphia, that the plants sold at one time as high as \$40 per 100, but the inferior flavor and unattractive appearance of the fruit caused it to decline steadily in favor, and now it has but few friends. Unlike others of its class it does not root

from the tips but propagates itself by suckers, producing them sparingly, however. When it was in such great demand, the nurserymen increased it by root cuttings, forced under glass.

In the next and concluding paper of this series, I shall continue the subject of raspberry culture, and consider the general treatment of gooseberries, currants, and blackberries, closing with some hints as to the picking and marketing of small fruits.

DWELLING-PLACES.

WHERE is thy home, O little fair head
With thy sunny hair, on earth's clouded way?

On my lover's breast, and I take my rest,
And I know no terror by night or day.

Where is thy home, O little fair heart
With thy joyous hope, 'mid earth's shadows dim?

In my lover's heart, and we never part,
For he carries me 'round the world with him.

Where is thy home, O little fair soul
So brave 'mid the old world's sorrow and care?

My home is in heaven. To me 'tis given
To win my lover to meet me there.

GIFTS.

A FLAWLESS pearl, snatched from an ocean cave
Remote from light or air,
And by the mad caress of stormy wave
Made but more pure and fair;

A diamond, wrested from earth's hidden zone,
To whose recesses deep
It clung, and bravely flashed a light that shone
Where dusky shadows creep;

A sapphire, in whose heart the tender rays
Of summer skies have met;
A ruby, glowing with the ardent blaze
Of suns that never set:—

These priceless jewels shone, one happy day,
On my bewildered sight:
"We bring from earth, sea, sky," they seemed to say,
"Love's richness and delight."

"For me?" I trembling cried. "Thou need'st not dread,"
Sang heavenly voices sweet;
And unseen hands placed on my lowly head
This crown, for angels meet.

OVER SUNDAY IN NEW SHARON.

WE reached New Sharon, my friend Eastman and I, at noon of a radiant Kansas Saturday. Our visit being merely one of curiosity, we could not fail to notice at first glance the uncouth and striking newness of everything; and yet it somehow seemed to us that the town might have been there always, so strongly did it hint in its very depth of grotesque freshness a strange, pathetic notion of decay, which even the all-pervading glare and scent of unpainted pine but slightly refuted. The buildings were of such varying and irrelevant patterns, and so lacking in neighborliness of size and attitude, that one was justified in wondering if they had not been bought at auction. Few of them boasted any underpinning, and many of them sat dizzily perched upon awkward corner-props, as if fearing a flood. There were no fences, and hence no door-yards; no trees and no awnings, and therefore an unchecked excess of sunlight. Above the town, a spray of sandy loam blew northward in frequent and rapid whirlwinds, and settled with a sort of resentful disdain about the overlooking cupola at the center of the public square ("the park," by courtesy), which proved to be the ambitious top of a structure designed to serve in time the purposes of a court-house, but contenting itself for the present with the humbler, though more popular, uses of a shooting-gallery. Here and there, too, tents were pitched, with blankets spread upon the guy-ropes; and opposite our hotel, a railroad freight-car, shorn of its wheels and squatting in the dust, abjectly besought patronage with a placard announcing "Meals at all hours."

The railroad denoted the boundary of the town proper on the south; and thence spread a succession of yellow pine-board pens, filled with cattle—antlered, uneasy, alien-looking cattle—out over the level bottom-land, pen after pen, until the boards became shadows, and the beasts lost their identity, and all that was left was a queer, sinister perplexity of uplifted and tossing horns. For New Sharon, let me hasten to explain, was what is known out West as "a cattle-town,"—that novel frontier village which belongs to a branch of commerce, an aspect of life, unknown elsewhere under the sun. Indeed, it was not possible even here so recently as fifteen years ago, when the vast plains of the Kansas border were the

sneer of geographers, and their short moss-like grass was supposed to be little more than a mimicry in nature, fit only for fire and frost to sport with and make ridiculous. But the railroad came along at length and spanned the desert, and the nimble-witted Kansan, putting this and that together, evolved the idea that a pasturage upon which the plentiful buffalo had lived and flourished for ages, perhaps—certainly ever since 1542, when the Spanish explorer Coronado crossed it and saw it populous with the "hump-backed oxen," as he described them—might be profitably utilized in grazing cattle to supply eastern markets. And so the immense herds roaming half wild upon the Texan pampas, and there valued only for their hides and tallow, were turned in this direction; and the scorned expanse of Kansas prairie from which the locomotive had but yesterday frightened the buffalo soon began to furnish fat, sleek beeves to New York, Philadelphia and Boston at the rate of hundreds of thousands a year. In round numbers, over four million head have thus been disposed of since 1870, and more than once the cattle-men of Kansas have been able to dictate prices as far away as Liverpool.

As a direct outgrowth of this new and important business, evoked from chaos, as it were, came the cattle-town—the converging point of the narrow, rambling trails to and from the outlying grazing-grounds, the rendezvous of the drovers and herders, the agreed depot for the collection, assortment, branding, sale and shipment of the cattle; and New Sharon, at the time we saw it, was chief of its class, and at the flood-tide of its activity and consequence. The town-site had been located less than a year before, it is true; but already the population—"counting transients," as the landlord phrased it—numbered as many as three thousand, while fully fifty thousand cattle were gathered there, awaiting purchasers and transportation; and all that the young city required to make her "the metropolis of the southwest," the landlord assured us, was a second railroad and some artesian wells for dry weather.

The street along which we strolled, while making our observations, was the main one of New Sharon—Grand Avenue, it was named: wide, like the road to Avernus, and side-

walked with long, slender, creaking planks, laid in the perfunctory and uncertain style of a midnight pontoon. The symbols and inscriptions over the doors and on the windows were largely of a nature to unsettle our confidence in what the landlord had told us in praise of the water of the locality; for the drinking-saloons outnumbered all other places of business, three to one. We counted seventeen of them in a distance of half as many rods, bearing such signs as "The Alamo," "The Snuggery," "Wallapus," "Old Fruit," "Dewdrop Inn," and in front of one of them we stopped to read, over the pier-glass and the pyramidal display of tumblers on the shelf behind the counter, this unique monition: "Drinks Cash. 'That's Mine' is Played Out." They were surprisingly quiet, though, it seemed to us, for summer afternoon purveyors of good cheer; and in many cases the bar-tenders, whom we recognized at once by their characteristic little white aprons and the pink elastics on their shirt-sleeves, were lounging outside the open doors, idly fumbling their long, gaudy watch-chains, or exchanging lazy chaff with their fellows across the street. The whole town, in fact, wore an ambushed and waiting air. Occasionally a solitary herder would canter by on his jaded and unwilling pony; at times we caught the subdued hum of a sewing-machine; and once a woman, the first we had seen since our arrival, drew aside a curtain and glanced out at us furtively, with red and curious eyes. But these were the only interruptions of the general lethargy, if we omit the solemn lowing of the cattle, which really tended to deepen rather than disturb the stillness.

Not until we had left the last of the houses behind us and Grand Avenue had trivialized itself to a cow-path, did we come upon a scene of life and animation. A kind of camp it looked to be, as of some beleaguering force just outside the crouched and apprehensive town; and it was astir and excited, like camps when marching orders reach them. A scout had arrived, we learned, with news of an attack by Indians upon a well-known stockade, a hundred miles to the south-west. He still sat his panting horse, and talked rapidly and with many gestures, and round about him were a score or more of cattle-herders—erect, sinewy, and strong-breasted fellows—pacing back and forth, listening to his story, plying him with eager questions, muttering at times to one another, and often pausing suddenly to gaze a moment across the dreary waste

of prairie, as though with an impulse to hasten at once to the rescue. It was a sight for a painter. Every face was a study. But in all of them alike beamed and flashed the peculiar intense and relentless look which you always see in the usually imperturbable faces of these sons of the border when the Indian occupies their attention. Such an expression of countenance, I think, is nowhere seen, except among men who, like these, have to grapple with the Indian problem as a personal matter. Can it be the sign of that rooted and irrepressible antagonism between the two races, which came in with the Pilgrims, and will go out, heaven only knows when?

We derived no light upon this point from the intelligent drover, whom we drew into conversation with us, and who appeared to be the leading spirit of the camp. He gave us his views of Indians and Indian affairs, however, in a very candid way; and they were such views as prevail generally on the frontier. He was in favor of annihilation, limited by opportunity and convenience, and believed General Sheridan to be the only "big man" who had ever dealt with "the red devils" in a sensible and successful manner. The Indians, he declared, had no respect for anything but superior force, and were, by nature, past all redemption, given over to vagabondage and deeds of rascality, treachery, and revolting cruelty; every attempt to teach them habits of industry had proved futile the moment it ceased to be compulsory; every effort to educate and Christianize them had failed to overcome, except for a time, their nomadic instincts and their thirst for blood; even one of the good Fathers at the Osage Mission, after more than thirty years of patient and pious labor among them, had recently confessed that he had never known a thoroughly civilized Indian, or one who would not at the first chance resume his blanket and moccasins, his paint and feathers, though schooled with all care for years in the books and ways of the whites. They have had wrongs, of course, he granted, "as most folks have had of one kind and another," but no such wrongs as warrant them in plundering and killing white men for pasture, and carrying women and children into a captivity which makes death a boon to be prayed for; in a certain sentimental sense, all this country was once theirs, to be sure—just as once all the world belonged to Adam—but they forfeited their claim upon it by allowing it to go untilled.

The whole thing, he added, with a good deal of warmth, is a matter of fore-ordination, of destiny; civilization has a supreme right to the earth, and civilization always has traveled, and always will travel Westward, "and if the Injun gets in the way, he'll have to get out of it, that's all."

During the early period of cattle-driving from Texas to Kansas, Indian attacks and fights were frequent, and the journey was one of military precaution and constant hazard; but in recent years, the drover told us, such events have been exceptional; the only regular annoyance from Indians now is their exaction of toll for the passage of cattle through the Territory; and outside of their reservations, one is rarely seen any more, unless it may be a dead one left on the trail by some scouting-party from an adjacent fort—"but I'd rather see one dead Injun than a dozen live ones, any day," he remarked. They have learned by experience to avoid the cattle men—"knowing we're always ready for 'em," the drover explained—and to make their raids, instead, upon the scattered and unprotected settlers along the Kansas border; and thus the trip that was once so exciting and thick with adventure has come to be an unspeakably cheerless and tiresome thing, with only a chance buffalo-chase (for the buffalo, too, is now seldom met with) or a race after jack-rabbits to relieve its prolonged monotony. About the first of April is the time the herds are started from Red River northward, and the aim is to reach the Kansas cattle-towns—distant some eight hundred miles—in the latter part of June, the route leading over the long, bleak "Chisholm trail," which goes winding and twisting this way and that, to suit the erratic bearings of the water-courses and strike conveniences for camping. Two herders to a hundred head of cattle is the rule—the herd often embraces five or six thousand head—and each herder has two horses, and is paid thirty to forty dollars a month, or twice that, if he owns his horses; a boss and a cook added to these, with wagons or pack-mules to carry provisions, and an abundant supply of fire-arms, saddles, lariats, blankets, and short-handled whips, and in some cases a few dog-tents, make up the "outfit," as it is termed. The herd is driven leisurely until noon, when there is a short stop for dinner; then the rate of travel is gradually increased, and kept up without rest or slackening, until the camping-place is arrived at and a halt made for the night; there the

cattle are huddled together, or "rounded up" in as small a compass as possible, called "the bed-ground," and the herders stand guard over them, by stated turns, like pickets, until morning comes and the fantastic expedition moves forward again—though sometimes a thunder-storm or other unexpected noise brings on a "stampede," and enlivens these prosaic night-watches (to the secret delight of the drowsy guards, we may guess) with a swift gallop into the grassy darkness after the terrified and fleeing cattle.

And so, day after day, the slow, dull drive continues, each day so like every other that soon all reckoning of its place in the week is lost, each passing scene so much a mere bald repetition that the whole outlook in a short time becomes simply one vast, featureless, confusing impression, like the ocean. Indeed, being adrift on these great, vague and melancholy prairies is very similar to being out at sea. The drover of whom I have spoken told us that he never made the journey without a continual, torturing heartache and sense of exile; and it is not improbable that the most ignorant and indifferent of the herders—perhaps even the worn and bewildered cattle, also—catch a hint of this feeling, could they formulate it in speech. Always, after a few days of the march, and a fair start into what may be called the sorcery of the intervening desert, a habit of silence and reverie and depression comes upon the entire outfit, save only the unaccountable little cow-birds—the Mother Carey's chickens of this singular argosy—that flutter cheerily and constantly round the herd the whole way from Red River to New Sharon. The songs and jokes die out, the storytellers cease to spin their coarse and knotted yarns, card-playing by the camp-fire is voted a bore, daily conversation dwindles to monosyllables. "Every man draws himself into his shell," as the drover expressed it; and there he remains, taciturn and brooding, unmindful of his companions and careless of himself, until, some lucky morning, a strange dog's bark, the crow of an early-rising rooster, or a bit of breakfast smoke from a homesteader's dug-out, rouses him from his dream, and with a thrill as of escape from long and nameless peril, he comes back to the world—alert, expectant, potential.

Once arrived in New Sharon, the herder, or "cow-boy," dominates the town. He is no longer the easy-going, mild-demeanored

type of native Texan languor and the anomalous self-repression of the trail; he "turns loose," as he calls it, and appears to change his disposition in the act of shifting his garments, so rapidly does he challenge every restraint of society, and sound every depth of vice and shame. Perhaps the sight of civilization, after so much of the desert and its high, haunting sky, stuns and dazes his moral nature; or possibly it is but the assertion, under tempting conditions, of that latent and ineradicable savagery which abides more or less in the best of us. Be the solution what it may, the fact is glaring that he no sooner reaches the town than he is straightway seized by some occult and masterful influence which transforms him like a new creation. He becomes a spendthrift, a drunkard, a gambler, a libertine, and too often, alas, a murderer! For him are the frequent saloons, the faro-banks and roulette-tables, the concert-halls, the dance-houses, and all the other various appliances of iniquity which meet the eye at every turn in such a place as New Sharon. It is a wonder that, in the wild excesses that he practices, and the manifold allurements that are set for him, he contrives to retain so much of manhood as he does; for it is undeniable that he is generous, truthful, sympathetic, honest in trade, brave to desperation—never a niggard, never a thief, and never a coward. He even has a strange, paradoxical code of personal honor, in vindication of which he will obtrude his life as though it were but a toy. Nor is he without the small infirmities of vanity that betray the common kinship of all humankind: he likes to display his small hands and feet; a smile from a woman flatters him; he has a passion for jewelry—extravagant scarlet bosom-pins are his specialty—and he dyes his mustache. He is tall and muscular, usually, with legs somewhat parenthesized by usage to the saddle; and his face, many times remarkable for its well-chiseled outline, is always thin and pale, and always grim—as if he wore a mask to conceal his inward loathing of the life he pretends to enjoy. And it is a life of short duration. A few whirling months, at most, of incessant carousal suffice to empty his purse, or exhaust his health; and then, if he be not yet quite lost to thought, he "braces up" as best he can, and slips away, and what finally becomes of him no one can tell—or he lingers still a little longer, and sinks still a little lower, until the brief candle is burnt

to the socket, and goes out at last in some drunken orgy, at the muzzle of a revolver, or the point of a quick and awful knife.

We saw it all, as in a panorama, Eastman and I, that unforgettable Saturday night in New Sharon. The dullness which had so weighed upon us through the long, uneventful afternoon was but a lull, we soon learned, and not a stagnation. With the first approach of darkness, the lethargic town rubbed its eyes, so to speak, and leaped to its feet—and in a twinkling, it seemed (like an incantation, Eastman said), Grand Avenue was a carnival of light, and motion, and music. The broad board sidewalks were crowded with promenaders; smiling groups passed in and out of the drinking-saloons and gambling-places; in every quarter glasses clinked and dice rattled (is there another sound in the world like that of shaken dice?); violins, flutes and cornets sent out eager, inviting strains of waltz and polka from a score or more establishments, and a brass band was playing patriotic airs in front of the theater, where, oddly enough, the crude morality of "Ten Nights in a Bar-Room" was about to be presented, "with the full strength of the company in the cast." Everywhere, the cow-boys made themselves manifest, clad now in the soiled and dingy jeans of the trail, then in a suit of many-buttoned corduroy, and again in affluence of broadcloth, silk hat, gloves, cane, and sometimes a clerical white neck-tie. And everywhere, also, stared and shone the Lone Star of Texas—for the cow-boy, wherever he may wander, and however he may change, never forgets to be a Texan, and never spends his money or lends his presence to a concern that does not in some way recognize the emblem of his native State: so you will see in towns like New Sharon a general pandering to this sentiment, and lone stars abound of all sizes and hues, from the big disfiguring white one painted on the hotel-front down to the little pink one stitched in silk on the cow-boy's shilling handkerchief. Barring these numerous stars, the rich lights, and the music, we missed sight of any special efforts to beguile or entrap passers-by—perhaps because we were not looking for them; nor was there for some hours a sound to reveal the spirit of coiled and utter vileness which the cheerful outside so well belied. It was in the main much the kind of scene one would be apt to conjecture for an Oriental holiday. But as the night sped on, the

festivities deepened, and the jovial aspect of the picture began to be touched and tainted with a subtle, rebuking something, which gradually disclosed the passion, the crime, the depravity, that really vivified and swayed it all, and made it infernal. The saloons became clamorous with profanity and ribald songs and laughter. There were no longer any promenaders on the sidewalks, save once in a while a single bleared and staggering fellow, with a difficulty in his clumsy lips over some such thing as "The Girl I Left Behind Me." An inflamed and quivering fierceness crept into the busy music. The lights paled, flickered, and here and there went out. Doors were stealthily closed, window-shutters slammed to with angry creaks. And at length, as we looked and listened, the sharp, significant report of a pistol, with a shriek behind it, was borne toward us from a turbulent dancing-hall to certify its tale of combat and probable homicide, and to be succeeded by a close but brief halt in the noisy quadrille—presumably for the removal of the victim.

It was then that Eastman and I turned away and sought our hotel. We could still hear from our bedroom the clatter of dice, the shuffling of feet, the murmur of confused voices, throughout most of the remaining night; indeed, it must have been quite daylight when the last of those reminding echoes reached us; and then, presently, the sun came climbing up to show us a Sabbath that was as placid and sweet as a psalm. Incredible, too, as it may sound, there were religious services in New Sharon that admirable forenoon, in an unplastered room over a bowling-alley, where we found a congregation of at least a hundred persons; and there were a choir and a cottage organ, and ushers showed us to seats when we entered. It looked a trifle out of form, even in New Sharon, to see a woman at church in a low-necked and short-sleeved crimson gown; but she seemed to be unaware of it. I diverted my fancy by likening her—I scarcely know why—to those women of olden, prophetic time, who "went out with timbrels and dances;" and that other one who sat near her, dressed in white, her hair in a braid down her back, and her fingers nervously twirling, as though they held unseen castanets—was not she a typical daughter of Babylon? I dared have been sworn I saw Desdemona there, also, and Iago, darting malevolent glances at her from across the aisle, the scoundrel! But Othello

was absent. I noticed Rob Roy present, however,—several Rob Roys, I may say,—booted and spurred in authentic fashion. For special wonder, too, walked in Werther, and stood with arms folded, spying pensively about for some random and sighing Charlotte. And we had not been men—at least, not men of taste—had we omitted to observe the violet-eyed miss with the curls and the silver-filigree jewelry, who sang soprano in the choir, and sang so charmingly well; for surely that face of hers, those lips, those cheeks, compelled many a sonnet, bankrupted many a heart, away back yonder in the time of Petrarch; only New Sharon was not much of a market for sonnets, nor did hearts break there with facility, I am inclined to think.

The minister read for the morning lesson, and for his text as well, the parable of the Prodigal Son. "He's going for 'em," Eastman whispered, and we sat anticipating an old-fashioned speech for the prosecution. To our surprise, not to mention our relief, we heard nothing of the kind. The sermon, I am bound to say, was original, good-tempered, and strikingly effective. If the speaker sketched the riotous part of the Prodigal's career rather freely and floridly—"as if he knew how it was himself," Eastman suggested—and touched the husks and swine, the grief and repentance, in a sparing and subordinate way, he but chose the method which Dubufe pursues, you remember, in that familiar picture of the same story; and he did not fail, as I think Dubufe does, to convey, somehow, a very distinct and serviceable impression that a life of wickedness is bad policy, at least. Likely he knew such to be his best way to reach his audience. Certainly he interested them and held their attention past a sign of flagging. I shall never forget how perfectly quiet they were, and how generally they leaned forward to listen, as he passed the strict letter of the parable and, leaving the father busy about the feast, went on to speak of the returned wanderer's supposititious and waiting mother—"We all have mothers, somewhere," he softly remarked—and to depict the homely, tender, caressing mood in which the dear wintry-haired and tottering old woman must have taken her boy—her youngest, and hence forever a baby in her eyes—back to the heart that had never ceased to love and pray for him. It was a stroke worth more than the acutest logic, I make no doubt. Then he abruptly reverted to the gay and ensnaring scenes which the Prodigal had found

so delightful for a time, and afterward so empty and so fatiguing, and dwelt upon them a few minutes earnestly, letting the background of shadow move a little further forward than before, and yet saying never a word of the grave, or the judgment on the other side of the grave. And then he paused for an instant or so, and when he spoke again it was in a voice of mellowed and lingering sweetness, and his words were the quaintly touching ones that good old George Herbert uses in his "Pulley," to tell how the Creator, when He had made man, hastened to equip him with blessing after blessing—strength, beauty, wisdom, honor, pleasure—till only *rest* remained, and how that one choicest boon of all was left unbestowed, to the end,

" * * * * that at least,
If goodness led him not, yet weariness "

might some day toss the longing and restless being to its Maker's breast. I could not for my life have told, when he had concluded, what denomination of Christians the minister belonged to; nor did it really seem to me to be a matter of any consequence.

We waited after service to make acquaintance with this surprising pastor, who proved to be a very frank and agreeable young man, liberally educated, who respected both his calling and himself, and who had also a keen eye for the absurd and incongruous, no less than the picturesque. He was able to tell us a great deal about New Sharon and its people; and it appeared to amuse him not a little that my idle psychology had in several cases so nearly grazed the truth regarding the certain types of individuality that I picked out in his congregation: my Iago was a specially accurate surmise, he had reason, he said, to know, but he doubted if my Desdemona would ever be smothered. While he made no pretense of hiding or excusing the common profligacy of the population that nightly possessed Grand Avenue, he must yet admit, he observed, that in his study of these rude characters, he had come upon some unflinching and distinctive traits which should be weighed to their credit. They were uniformly faithful where duty was a deciding cause; their obligations of friendship were never broken or evaded; their promises were as plighted oaths, which they redeemed at any cost; they hated shams and every form of hypocrisy; they scorned to take a mean, underhand advantage, even of a mortal enemy; and the sight of misfortune or

suffering made children of them in pity and gentleness and practical charity. For himself, personally, he had never been insulted or interfered with, nor heard of his work being openly scoffed at, and we would be astonished, he affirmed, to know how much genuine respect the worst of these people, including such of them as never thought of attending church services, had for religion as a fact and a force in their midst. I wondered if those few enduring peculiarities of fidelity, veracity and compassion, and this lurking reverence for things clean and spiritual, were not tokens of the un-fallen angel in man that wrestles with him to the end of his days. The minister gave us to infer that he shared the conceit. "Bad as they are," he said, "they don't want to go to hell. But they like the road that leads there." Would it be too much to assert that this terse analysis went to the very core of the riddle of sin, not in New Sharon merely, but the whole world over?

He was quite sorry, the minister informed us, that we could not meet Mr. Bartholomew, the baritone of his choir, a remarkable man in his way, an old plainsman of Frémont's time, who so liked to sing sacred music that he has abandoned the business of liquor-selling and left off hard drinking and other incommoding vices that he might have a place in the choir; "but unfortunately," he explained, "Bartholomew has the only pack of hounds in town, and he had to go out hunting to-day with a party of officers from the fort." We could not altogether repress a smile at this, in which the minister courteously joined. There was something inexpressibly sad, though, in what he told us later about the little violet-eyed soprano, whose singing we had assured him would bring us to evening service whether the baritone with the unmelodious dogs should return or not. "I regret it very much," was his slow reply, "but she sings for us in the morning only; she is a performer at the Melodeon concert-hall, and can't be spared in the evening, even a Sabbath evening."

We had the likeable minister for a companion on our visit after dinner to New Sharon's burying-ground, on the green and cool-looking elevation back of town—Boot Hill, they called it, from the fact that all those buried there had died, in the graphic vernacular of the border, "with their boots on." There were thirty-eight of the graves, some of them with unsightly white crosses above them, others marked by yellow

crumbling stones, like those surveyors employ to specify section-corners, and still others were but sunken, pitiful spots that spoke of hasty and careless sepulture. Two of the crosses bore women's names, we discovered—for the sex has its rights on the border. And on one of the neighboring mounds (heaped a trifle higher than any of the rest, I fancied), a weed-choked and low-spirited little arbor-vitæ was trying to keep somebody's memory green. But as a rule, there were no indications that the departed had left friends or relatives behind them, or that New Sharon esteemed it her duty to do anything more for Boot Hill than to exempt it from taxation, and get it talked about in the newspapers. There was even a lack of ordinary plan or regularity in the location of the graves; a spirit of giddy and rollicking contempt for straight lines and parallel head-boards ran riot on every hand, and the dead slept in a general snarl as to the points of the compass. It is only fair to state, however, that at the digging of the very first of the graves, quite a contention had occurred among the by-standers concerning the direction in which the head of the deceased should be placed, and the obsequies threatened to end in a public scandal, until Judge Vanderpool, New Sharon's justice-of-the-peace, dexterously adjusted the issue, for that day and for all time, by saying: "What's the difference, anyhow? When Jehovay wants a man He can find him, no matter how he happens to be planted." And yet, in spite of this extenuation, the place seemed to us an ill-favored one to tarry in on such a perfect and enjoyable day, and we chose to be quit of it very shortly: it was much pleasanter to sit in the shade of the hotel porch, and hear our entertaining minister talk of the strangely warped and perturbed lives which had gone to fill those dreadful graves.

I blush to own that we did not return to church service that evening; but, then, neither did we patronize the concert-hall, where we knew our pretty soprano was singing; nor did we go sauntering on Grand Avenue, as so many were doing. It was a bland, moonlit, beautiful night, and we rambled aimlessly out along the railroad-track, away from easy hearing, but still within sight of the town, until suddenly we found ourselves looking upon the Conwell cottage, as it was styled. The open prairie lay about it, and no other building could be seen for a mile or more in any direction; it was untenanted and dark; and though now sorely beset by

creeping vines, and things that grow only where silence invites them, we could yet see that it had at one time been temptingly neat and cozy—and our imagination readily restored it to life, and brightness, and abounding merriment.

It was the landlord—or was it the minister?—who had rehearsed for us the mysterious and bitter story of this deserted cottage. The man whose name still clung to it, and set it apart, had built it while Grand Avenue was but grass and cacti, and New Sharon only a ranch where accidental Santa Fé freight-wagons halted overnight. No stranger site could have been selected for such a bird-cage of a dwelling; and when Conwell brought a woman to live in it with him,—a woman of wonderful beauty, with ever so many rich dresses, and diamonds, and a laugh like a lark's song (the ranchmen said),—it was romantic and perplexing enough for a novel. But by and by the railroad arrived, and the town was started, and the cow-boys occupied the scene; and then, one day, there came a portly, bearded man, who talked in low and coaxing tones, but with a wild look in his eyes. This man inquired for Conwell and the handsome woman, particularly the woman. Nobody knew, of course, what his errand was; had the townsfolk suspected it, they would hardly have shown him the cottage. He found her there, alone—attired as if for a ball—and asked her to tell him the truth, on her soul, it is supposed; and when she had finished, he deliberately shot her to the heart, kneeling at his feet. Then he stooped and lifted her up, and stood with her in his arms, when some passing herdsmen thrust open the door to see what had happened. He laid the dead body on a couch, directly, looked at it intently for a moment, took one of the hands in his, and spoke to those about him: "She was mine, and I killed her. She's good and white again at last. I've saved her." The limp hand dropped, and he seemed talking to himself, as he added: "If she had loved him, he might have had her, for all of me; but she didn't love him, she told me she didn't. It was the fine clothes, the fine clothes!" Then he bent over and kissed her forehead once, solemnly. A minute later he had turned his back upon her; and he said with a ghastly smile: "I feel easier in my mind than I've felt afore in two years. I'll go now." And that was all—no one offering to stop him or to question him, even when he walked

aboard of the train next morning; and Conwell never came back to the cottage any more; and the cottage itself was shunned and surrendered to the vines and weeds, as we saw it.

I know not what impulse led our unintentional steps from the cottage to Boot Hill again, nor can I tell why it was that, once there, we went straight to where they had told us this woman was buried; but I hope we did no improper or foolish act when we plucked a few straggling wild flowers and cast them, one by one, upon her grave. Poor hunted and slain thing! Perhaps it was her fate as much as her fault,

after all. For she was very beautiful, every one said; and oftentimes beauty is given to woman to be her burden, is it not?

The air was soft and gracious as we started to descend the hill. In a clump of screening sage-bushes, birds were twittering their good-nights from nest to nest. We could see the tender moonlight coming and going over the roofs of New Sharon, as if with a message of propitiation and peace. And beyond the shadowy town, stretching away off to the sky-line, lay the great, inexplicable domain of prairie—gray, lone, and oblivious—

“Rapt in a dream of God.”

THE WARDS OF THE UNITED STATES GOVERNMENT.

THAT the Indians should be called “wards” of the United States Government, would seem a natural thing, significant of the natural relation between the United States Government and the Indian. The dictionary definition of the word “ward” is “one under a guardian,” and of the word “guardian,” a “protector.” For white orphans under age, guardians are appointed by law; and the same law defines the duties and sets limit to the authority of such appointed guardians. The guardianship comes to end when the orphan ward is of age. This is one important difference between the white “wards” in our country, and Indian “wards.” The Indian “ward” never comes of age. There are other differences, greater even than this; in fact, so great that the term “ward” applied to the Indian, savors of a satire as bitter as it was involuntary and unconscious on the part of the Supreme Court, which, I believe, first used the epithet, or, if it did not first use it, has used it since, as a convenient phrase of “conveyance” of rights, not to the Indian, but from him; to define, not what he might hope for, but what he must not expect; not what he is, but what he is not; not what he may do, but what, being a “ward,” he is forever debarred from doing. Among other things, he may not make a contract with a white man, unless through his guardian, the Government. He may not hire an attorney to bring any suit for him, unless by consent of his guardian, the Government. Strangely enough, however, though as an individual he cannot make a contract or bring a suit,

he has, until six years ago, always been considered fit, as a member of a tribe, to make a treaty; *i. e.*, if the treaty were with the United States Government, his guardian.

This relationship of “ward” and “guardian” between the Indian and the United States Government is of long standing, as is also the practice of treaty-making between them. It began more than a hundred years ago, when, oddly enough, the “wards” were more powerful than the “guardian.” But even then, the object the United States Government professed to have in view was “to elevate, civilize, and educate” them “by furnishing them with useful, domestic animals, and implements of husbandry.” This was the verbal phrase in the treaty made with the Five Nations, in 1791. There were treaties even earlier than this; notably, a treaty, “a perpetual alliance, offensive and defensive,” which we made with the Delaware Indians in 1778. It is a matter of history how well the Delawares fought for us in the Revolutionary War. They were brave and efficient allies, and were inspired in their fighting not only by the sentiment of loyalty to the “alliance,” but by the hope of the reward promised them, *i. e.*, “the territorial right to a state as large as the State of Pennsylvania,” and “a right to representation in our Congress.” In 1785 the Delawares were moved to Ohio and Indiana; in 1818, to Missouri and Arkansas; in 1829, to Kansas. Here they were all gathered together under renewed promises of a permanent home. Where are they to-day? In Indian Terri-

tory, all that are left of them; some are with the Cherokees; some on the Wichita Agency, where they are trying to farm, though last summer, were unable to cultivate as much ground "as was intended," "on account of loss of stock by horse thieves" [see Report of Ind. Com. for 1877, p. 112]; it is a little inconvenient for a "ward" at such distance from his "guardian," not to be able to bring a suit against a thief, without authorization from the "guardian."

There are not so many of the "wards" now as there were once. "We have, in two hundred and fifty years, wasted their numbers from 2,500,000 down to 250,000; or a waste of number equal to all their children born to them in the last 250 years," says the Minority Report of the Joint Com. appointed by the two houses of the XLIVth Congress, to consider the expediency of transferring the Indian Bureau to the War Department. Neither are they so well off as they once were, for they have been compelled to sell the greater portion of their lands to their "guardian." "The United States Government has taken absolute ownership of 3,232,936,351 acres of their lands, leaving to all the tribes collectively only 97,745,009 acres of ground," says the same Report. Nevertheless, they are not yet paupers, neither do they live entirely on the charity of their "guardian," as many people suppose, seeing mention made every year of large sums of money appropriated by Congress for supplies and payments to the different tribes of Indians.

When the "wards" have made "treaties" and "sales" to their guardian, the transaction has been thus: "Generally, the commissioners who made the treaty estimated the value of the right of occupancy of the Indians, and paid the consideration, either in a gross sum or in an amount of money or goods. The money is delivered to the agents, or chiefs, or more frequently deposited with the United States, invested in government securities, and held in trust for the tribe to which it belongs. The whole amount of these trust funds is \$13,069,475, on which interest of four and one-half per cent. is allowed." [See "The Indian Problem, by Gardner Hubbard," p. 11.]

There are people—and their number seems increasing in our country every day—who hold that the Indian's "right of occupancy" was never any "right" at all—was nothing that he had the power to sell, or white men need have troubled themselves to buy. As a nation, however,

we have recognized this right in hundreds of treaties, "confirmed by the Senate as are treaties with foreign powers," and recognizing the Indian tribes "as nations with whom the United States might contract, without derogating from its sovereignty."

"In the early history of the Western World, the principle was fully recognized that, while sovereignty rested, not with the Indians, but with the civilized power claiming by virtue of discovery, the Indians were the rightful occupants, with a just and perfect claim to retain possession and enjoy the use until they should be disposed voluntarily to part with it. Great Britain, Holland, France and Spain, the four powers claiming sovereignty, by virtue of discovery, within the present territory of the United States, conceded no less than this to the natives; while France, in the cession of the Province of Louisiana, expressly renewed the rights allowed the Indians by its own treaties and articles, 'until by mutual consent of the United States and the said tribes or nations, other suitable articles shall have been agreed upon.'" —["The Indian Question." By Francis A. Walker, late United States Commissioner of Indian Affairs," page 10.]

The accumulated inconvenience, embarrassment, and costliness of making such treaties and purchases by treaty,—perhaps, also, some sense of the accumulating infamy of breaking such treaties and violating the terms of such purchases by treaty—so weighed upon the minds of the representatives of the American people, that on the 3d of March, 1871, it was declared by an Act of Congress, that:

"No Indian nation or tribe within the territory of the United States shall be acknowledged or recognized as an independent nation, tribe, or power with whom the United States may contract by treaty." [See Sec. 2,079, Chap. II., Title XXVIII. of the United States Revised Statutes.]

Could it have been in satire that these law-makers added a clause to the effect that this Act should not invalidate any treaties made previous to that date? Was there one treaty left which had not been broken?

There is a certain sort of defiant outspokenness in this Act which compels a certain kind of respect. It openly and—if legality of phrase can make an outrage legal—legally takes away from the Indian his one semblance of legal right, and leaves him, at last, completely at the mercy of the untrammelled power of the Government. Nevertheless, I repeat, that for the Government to trick and break faith with the Indians now seems one shade less dishonorable than before; as to be a highwayman seems one shade less degrading than to be a pick-pocket.

It is only a little more than fifty years

since the British envoys at Ghent charged the United States with "having reduced the Indians to the state of subjects living on sufferance within their limits, and threatened thereby with total extinction." To this accusation our commissioners, John Quincy Adams and Albert Gallatin, replied as follows:

"The Indians residing within the United States are so far independent that they live under their own customs and laws, and not under the laws of the United States; that their rights on the lands which they inhabit or hunt are secured to them by boundaries defined in amicable treaties between the United States and themselves; and that whenever those boundaries are varied, it is also by amicable and voluntary treaties, by which they receive from the United States ample compensation for every right they have to surrender."

This was in 1814. Before the first half of the century had gone, we had broken seven solemn treaties with the Creeks, eleven, equally solemn, with the Cherokees, and as many with the Chickasaw and Choctaw nations, to say nothing of those with smaller tribes.

The experience of the Cherokees is a sad and infamous page of our history. A new treaty made with them, in 1828, begins:

"Whereas, It being the anxious desire of the Government of the United States to secure to the Cherokee nation of Indians a permanent home, and which shall, under the most solemn guarantee of the United States, be and remain theirs forever, a home that shall never in all future time be embarrassed by having extended around it lines, or placed over it the jurisdiction of a State or Territory, nor be pressed upon by the extension over it in any way of the limits of any existing State or Territory, the parties hereto do conclude the following articles, viz.:" * * * [See U. S. Statutes at large, vol. vii., p. 311.]

Ten years later, the United States Government, at the request of the State of Georgia, compelled the Cherokees to give up the lands guaranteed to them by this treaty, and move to the Indian Territory. By this time, the Cherokees were a civilized people; and there were among them men who were sufficiently skilled in the use of words to insist upon the insertion, in the treaty, of this clause:

"Article V.—The United States hereby covenant and agree that the lands ceded to the Cherokee nation in the foregoing article, shall in no future time, without their consent, be included in the territorial limits or jurisdiction of any State or Territory."

The opening words of this treaty are full of pathos.

"Whereas, The Cherokees are anxious to make some arrangements with the Government of the United States, whereby the difficulties they have experienced by a residence within the settled parts of the United States, under the jurisdiction and laws of the State governments, may be terminated; and with the view of reuniting their people in one body, and securing a permanent home for themselves and their posterity, * * * therefore," etc.

And to-day a bill is before Congress to create a Territorial government over these "lands ceded to the Cherokee nation."

With the Winnebagoes the United States Government made five treaties between 1816 and 1855. The treaty of 1855 guaranteed to them a reservation in Minnesota, where they lived until 1862, "peaceably engaged in agriculture," and loyal to the United States, even when surrounded and threatened by bands of hostile Sioux. After the outbreak of the Sioux, the citizens of Minnesota were "so determined that all Indians should be removed beyond the limits of the State, that Congress passed an Act in 1863 providing for their removal. [See "The Indian Question. By Francis A. Walker," p. 178.] After the loss of many lives by exposure and starvation in Dakota, they were finally settled in Nebraska, on a reservation adjoining that of the Omahas. Doubtless, when Nebraska becomes a "determined" as Minnesota was in 1863, and as Georgia was in 1838, that "all Indians shall be removed" beyond her limits, Nebraska will plead "precedents," as Colorado to-day is pleading the long list of shameful precedents which have gone before. When Nebraska does this, then the Winnebagoes, the Omahas, the Sacs and Foxes, the Otoes, the Missouriias, and the Santee Sioux, all living now on reservations ceded to or set apart for them there by the Government, will be added to the list of "Removed to the Indian Territory."

The stories of the sufferings, deaths, and massacres which come under the head of these "removals" would fill volumes; they can never be fully told, because the dead cannot tell them. From time to time the hearts of the American people are sickened and rent by sudden news of one more, such as the massacre of the Cheyennes at Fort Robinson, or the dying of the Nez Percés and the Poncas by hundreds in Indian Territory. It would seem as if the hearing of one of these tales were enough to arouse the whole American nation to a sense of the cruelty of thus oppressing the Indian. But too often the tale is told from the white man's side, and not

from the Indian's; the murders which are the only defense or retaliation left within the Indian's power, are held up to view as unprovoked acts of barbarous savages. And this, in spite of testimony upon testimony, given by men who best know the facts of Indian wars, and the real quality of the Indian nature.

"It is only what the Indian does to the white man that is published to the country, never what the white man does to the Indian."—[Official Report of General Pope, June, 1864.]

The story of the Nez Percé war, consequent on the attempt of the United States Government to "remove" this tribe from their homes, is still fresh in the minds of the American people, and is not yet complete on the official records of the Government. It is one of the few cases in which the Indian's side of the story has been told, and it is, therefore, one of the few cases which can be cited with anything like fairness.

The three chief sources of information in regard to the experiences of these Nez Percé "wards" of the United States Government are the official reports of Commissioners of Indian Affairs, a remarkable paper written by Chief Joseph of the Wal-lam-wat-kin band of Nez Percés, called "An Indian's Views of Indian Affairs," and published in the "North American Review" for April, 1879, and a reply to that article, written by General O. O. Howard, called "The True Story of the Wallowa Campaign," and published in the "North American Review" for July, 1879. It seems an oversight on the part of General Howard to call his paper "The True Story of the Wallowa Campaign," when, in fact, it speaks only of the events preceding the battles of that campaign, of the councils, agreements and final decisions in the matter of the removal of the Nez Percés, and only alludes in a few words, near the close, to the fact of the fights and the surrender of the Indians. He says that some of the Indians "treacherously escaped after the terms of surrender had been agreed upon," and thus did "break and make void the said terms of surrender." Is this the law of nations at war? If a few soldiers contrive to run away, after an army has surrendered, does that invalidate the conditions on which the generals of the two armies had agreed? General Howard expressly omits to state what those "terms of surrender" were; and by this omission, he gives the strongest proof that Chief Joseph, in his article, did not misrepresent them.

The beginning of the Nez Percé trouble was in the appointment, at Washington, of "a commission to visit the Nez Percé and other roving bands of Indians in Idaho, Oregon, and Washington Territory." [See Report of Ind., Com. for 1877, p. 211.] This word "roving" is one of the many current phrases of misrepresentation about the Indians. "Roving bands," "nomadic tribes," are catch-words for popular contempt and popular fear. In the true sense of the word, there is no such thing among our Indians as a "nomadic tribe."

Of these same Nez Percé Indians, this same official report (p. 80) says, they "seldom leave their homes except when called away on business. * * They do their trading semi-annually, in the spring and fall, returning home as soon as they have got through with their business!" and in the Report of the Indian Commissioner for 1874, p. 12, we find this statement:

"Experience shows that no effort is more unsuccessful with an Indian than that which proposes to remove him from the place of his birth and the graves of his fathers. Though a barren plain without wood or water, he will not voluntarily exchange it for any prairie or woodland, however inviting."

Between the accounts given by General Howard, and by Chief Joseph, of the events preceding the Nez Percé war, there are noticeable discrepancies.

General Howard says that he listened to the "oft-repeated Dreamer nonsense of the chief, 'Too-hool-hool-suit,' with no impatience, but finally said to him:

"Twenty times over I hear that the earth is your mother, and about the chieftainship of the earth. I want to hear it no more."

Chief Joseph says:

"General Howard lost his temper and said 'Shut up! I don't want to hear any more of such talk.' Too-hool-hool-suit answered, 'Who are you, that you ask us to talk, and then tell me I shan't talk? Are you the Great Spirit? Did you make the world?'"

General Howard, quoting from his record at the time, says:

"The rough old fellow, in his most provoking tone, says something in a short sentence, looking fiercely at me. The interpreter quickly says: 'He demands what person pretends to divide this land, and put me on it?' In the most decided voice, I said, 'I am the man. I stand here for the President, and there is no spirit, bad or good, that will hinder me. My orders are plain, and will be executed.'"

Chief Joseph says: "General Howard replied, 'You are an impudent fellow, and I will put you in the guard-house,' and then ordered a soldier to arrest him."

General Howard says: "After telling the Indians that this bad advice would be their ruin, I asked the chiefs to go with me to look at their land. 'The old man (Too-hool-hool-suit) shall not go. I will leave him with Colonel Perry.' He says, 'Do you want to scare me with reference to my body?' I said, 'I will leave your body with Colonel Perry.' I then arose and led him out of the council, and gave him into the charge of Colonel Perry."

Chief Joseph says: "Too-hool-hool-suit made no resistance. He asked General Howard, 'Is that your order? I don't care. I have expressed my heart to you. I have nothing to take back. I have spoken for my country. You can arrest me, but you cannot change me, or make me take back what I have said.' The soldiers came forward and seized my friend, and took him to the guard-house. My men whispered among themselves whether they should let this thing be done. I counseled them to submit." * * Too-hool-hool-suit was prisoner for five days before he was released."

General Howard, it will be observed, does not use the word "arrested," but as he says, later, "Too-hool-hool-suit was released on the pledge of Looking Glass and White Bird, and on his own earnest promise to behave better," it is plain that Chief Joseph did not misstate the facts. This Indian chief, therefore, was put under military arrest, and confined for five days, for uttering what General Howard calls a "tirade" in a council to which the Indians had been asked to come for the purpose of consultation and expression of sentiment.

Does not Chief Joseph speak common sense, as well as natural feeling, in saying, "I turned to my people and said, 'The arrest of Too-hool-hool-suit was wrong, but we will not resent the insult. We were invited to this council to express our hearts, and we have done so.'"

If such and so swift penalty as this, for "tirades" in council, were the law of our land, especially in the District of Columbia, it would be "no just cause of complaint" when Indians suffer it. But considering the frequency, length and safety of "tirades" in all parts of America, it seems unjust not to permit Indians to deliver them. However, they do come under the head of "spontaneous productions of the soil"; and

an Indian on a reservation is "invested with no such proprietorship" in anything which comes under that head.—[Annual Report of the Indian Com. for 1878, p. 69.]

Chief Joseph and his band consented to move. Chief Joseph says:

"I said in my heart that rather than have war I would give up my country. I would give up my father's grave. I would give up everything rather than have the blood of white men upon the hands of my people."

It was not easy for Joseph to bring his people to consent to move. The young men wished to fight. It has been told that, at this time, Chief Joseph rode one day through his village, with a revolver in each hand, saying he would shoot the first one of his warriors that resisted the Government. Finally, they gathered all the stock they could find, and began the move. A storm came, and raised the river so high that some of the cattle could not be taken across. Indian guards were put in charge of the cattle left behind. White men attacked these guards and took the cattle. After this Joseph could no longer restrain his men, and the warfare began, which lasted over two months. It was a masterly campaign on the part of the Indians. They were followed by General Howard; they had General Crook on their right, and General Miles in front, but they were not once hemmed in; and, at last, when they surrendered at Bear Paw Mountain, in the Montana Hills, it was not because they were beaten, but because, as Joseph says, "I could not bear to see my wounded men and women suffer any longer; we had lost enough already." * * "We could have escaped from Bear Paw Mountain if we had left our wounded, old women and children, behind. We were unwilling to do this. We had never heard of a wounded Indian recovering while in the hands of white men." * * I believed General Miles, or I never would have surrendered. I have heard that he has been censured for making the promise to return us to Lapwai. He could not have made any other terms with me at that time. I could have held him in check until my friends came to my assistance, and then neither of the generals nor their soldiers would ever have left Bear Paw Mountain alive. On the fifth day I went to General Miles and gave up my gun, and said, 'From where the sun now stands, I will fight no more.' My people needed rest—we wanted peace."

The terms of this surrender were shame-

fully violated. Joseph and his band were taken first to Fort Leavenworth and then to the Indian Territory. At Leavenworth they were placed in the river bottom, with no water but the river water to drink.

"Many of my people sickened and died, and we buried them in this strange land," says Joseph. "I cannot tell how much my heart suffered for my people while at Leavenworth. The Great Spirit Chief who rules above seemed to be looking some other way, and did not see what was being done to my people."

Yet with a marvelous magnanimity, and a clear-headed sense of justice of which few men would be capable under the circumstances, Joseph says:

"I believe General Miles would have kept his word if he could have done so. I do not blame him for what we have suffered since the surrender. I do not know who is to blame. We gave up all our horses, over eleven hundred, and all our saddles, over one hundred, and we have not heard from them since. Somebody has got our horses."

This narrative of Chief Joseph's is profoundly touching; a very Iliad of tragedy, of dignified and hopeless sorrow; and it stands supported by the official records of the Indian Bureau.

"After the arrival of Joseph and his band in the Indian Territory, the bad effect of their location at Fort Leavenworth manifested itself in the prostration by sickness at one time of 260 out of the 410; and 'within a few months' in the death of 'more than one quarter of the entire number.'"—[Annual Report of the Indian Commissioner, for 1878, p. 33.]

"It will be borne in mind that Joseph has never made a treaty with the United States and that he has never surrendered to the Government the lands he claimed to own in Idaho. * * Joseph and his followers have shown themselves to be brave men and skillful soldiers who, with one exception, have observed the rules of civilized warfare. * * These Indians were encroached upon by white settlers, on soil they believed to be their own, and when these encroachments became intolerable, they were compelled in their own estimation to take up arms." [Same Report, p. 34.]

Chief Joseph and a remnant of his band are still in Indian Territory, waiting anxiously the result of the movement now being made by the Ponca chief, Standing Bear, and his friends and legal advisors to

obtain from the Supreme Court a decision which will extend the protection of the civil law to every Indian in the country.

The Nez Percés who escaped after this surrender took refuge in the camp of the Sioux Chief, Sitting Bull, in Canada, and no doubt they were able to add sarcastic emphasis to the assurances given by General Terry to Sitting Bull that if he and his band would return to the United States, they should be "treated in as friendly a spirit as were other hostile Indians who surrendered to our military forces."

This council must have been a dramatic spectacle. Three men were sent by the United States Government into Canada, to hold converse with some of the "wards" who had run away; empowered to offer them, if they would come back, pardon and cows in exchange for their horses and rifles. General Terry said:

"The President invites you to come to the boundary of his and your country, and there give up your arms and ammunition, and thence to go to the agencies to which he will assign you, and there give up your horses, excepting those which are required for peace purposes. Your arms and horses will then be sold, and with all the money obtained for them cows will be bought and sent to you."—[Report of the Sec. of the Interior, 1877, p. 723.]

The phrase "his and your country" seems a strange one, in a paragraph of this sort. It did not impress Sitting Bull very deeply, and the allurements mentioned—the giving up all arms, horses, etc., and the certainty of being "assigned" to "agencies" here and there, even with the prospect of "cows," did not entice him away from Canada. His reply is full of satire. It would seem that even the officers to whom it was addressed must, in spite of its affront to their dignity, have enjoyed the speech. He said:

"For sixty-four years you have kept me and my people, and treated us bad. * It is all the people on your side that have started us to do all these depredations. We could not go anywhere else, and so we took refuge in this country. * * You have got ears, and you have got eyes to see with them, and you see how I live with these people. You see me? Here I am. If you think I am a fool, you are a bigger fool than I am. * You come here to tell us lies, but we don't want to hear them. I don't wish any such language used to me—that is, to tell me such lies in my Great Mother's house. Don't you say two more words. Go back home where you came from. This country is mine, and I intend to stay here, and to raise this country full of grown people. * * I wish you to go back, and take it easy going back."

Another chief said:

"Sixty-four years ago you got our country, and

you promised to take good care of us and keep us. You ran from one place to another, killing us and fighting us. * * I come in to these people here and they give me permission to trade with the traders. That is the way I make my living. * * I am going to live with these people here."

So great was the scorn felt by these Indians for this embassy that they even permitted a squaw to address it.

"A squaw named 'The-One-that-Speaks-Once,' wife of 'The-Man-that-Scatters-the-Bear,' said: 'I was over at your country. I wanted to raise my children over there, but you did not give me any time. I came over to this country to raise my children and have a little peace. That is all I have to say to you. I wish you to go back where you came from. These are the people that I am going to stay with and raise my children with.'"

After the Indians had finished speaking they asked if the Commission had anything more to say, to which the Commission answered that they had nothing more, and the conference closed. "The Commission returned," says the Report (p. 413), "and Sitting Bull and his adherents are no longer considered wards of the Government."

It is not strange that the Indians prefer Canada to the United States. There has been no war with or upon Indians there, since the Revolution. There are 100,000 Indians in Canada. They are called "the Indian subjects of her Majesty," and are held in every respect amenable to the law and are in every respect protected by the law. Says Bishop Whipple:

"On one side the line is a nation that has spent \$500,000,000 in Indian wars, a people who have not a hundred miles between the Atlantic and the Pacific which has not been the scene of a massacre, a government which has not passed twenty years without an Indian war; not one Indian tribe to whom it has given Christian civilization, and which celebrates its centenary by another Indian war.

"On the other side of the line are the same greedy, dominant, Anglo-Saxon race—the same heathen. Yet they have not spent one dollar in Indian wars, and they have never had a massacre."

The latest "removal" of "wards" and seizure of their lands is that of the Poncas, who were removed from Dakota to Indian Territory two years ago. Their lands in Dakota had been ceded to them by treaties in 1817, 1828, 1858, and 1865. Article II. of the Treaty of 1865 says:

"In consideration of the cession or release of that portion of the reservation, above described, by the Ponca tribe of Indians to the Government of the United States, the Government of the United States, by way of rewarding them for their constant fidelity to the Government and citizens thereof, and with a view of returning, to the said tribe of Ponca Indians,

their old burying-grounds and corn-fields, hereby cede and relinquish to the tribe of Ponca Indians the following described fractional townships."

Then follows a description of certain townships and sections. The title is as strong a title as the Government can give. No man, no chartered railroad, has one any stronger. These Poncas, it is admitted,—

"have always been friendly to the whites. * The orders of the Government always met with obedient compliance at their hands. Their removal from their homes on the Missouri River was, to them, a great hardship. They had been born and raised there. They had homes there in which they lived according to their ideas of comfort. Many of them had engaged in agriculture, and possessed cattle and agricultural implements."—[Official Report of the Secretary of the Interior, p. 8.]

In three months after the arrival of the Poncas in the Indian Territory, over one hundred and fifty out of the seven hundred were dead. Then, one of the chiefs, named Standing Bear, ran away with thirty of his people, and tried to return to Dakota. He carried with him the bones of his eldest son, who, when he was dying, had asked his father to promise to bury him at home—a strange request for a "nomadic" Indian to make! The Government sent troops after this band, overtook them, arrested them. More than half were women and children. On their way back to the Indian Territory, they were camped near Omaha. Here they were visited by A. F. Tibbles, an Omaha editor, who resolved to test the question of the legality of their confinement as military prisoners. The case was tried in the Supreme Court of Nebraska, and by decision of Judge Dundy, the Indians were set free. They are the only free Indians in the United States to-day, except a few who are under State governments. The first use Standing Bear made of his freedom was to journey to the Eastern states, to endeavor to raise money to bring suits for the recovery of the Ponca lands, and also suits in the Supreme Court of the United States, to determine for all Indians, as Judge Dundy had determined for him, that an Indian is a "person," and has all the rights guaranteed by the Fourteenth Amendment. This movement has been responded to with great enthusiasm in some of the Eastern cities, and all that money and public sentiment can do will be done to help the cause of the Poncas, and in theirs, the cause of all the other "wards of the Government." Arrayed on the other side are the colossal forces of selfishness, greed, love of power; and

allied to these, the subtlest and most despicable of allies—our national lack of a sense of honor. These words sound harsh, but what other words are truly applicable to a nation which, for one hundred years, has broken every treaty it has made with a people too feeble to punish its bad faith?

Even since the first words of this article were written a United States representative has angrily argued in Congress that it is very hard if the Government will not, for

Colorado's advantage, break a few treaties, when it has broken so many for the advantage of other States—has said this in so many words, and there was no man to interrupt him with the cry of "shame!"

What a logic of infamy! Because a nation has broken treaties, violated pledges, committed injustices and cruelties, for a hundred years, it may as well go on breaking treaties, violating pledges, being unjust and cruel? Because we have had one century of dishonor, must we have two?

A LOVER'S ANSWER.

WHAT is she like—my own, my queen of pearls?
 Like every thing that God has made for love;
 Like birds, and flowers, and songs, and sweet June days.
 A summer rose whose leaves have fallen apart,
 Blush after blush down to its perfect heart.
 Is full of her and all her tender ways.
 The cooing of a silver-throated dove
 Echoes her tones; the brooklet's babbling whirls
 Mimic her laughter; showers from an April sky
 Her glistening tears. Her smiles!—ah, evermore
 On the cool bosom of the sea they lie,
 And ripple, ripple, ripple to the shore.

What is she like? Like to no human thing.
 The fragrant balmy breath of opening Spring
 Is like her sigh; the heavy odorous air
 Seems thrilling with her presence everywhere;
 All the sweet luscious fruits that summer brings
 Are like her words; the butterfly's bright wings,
 Quivering in light, are radiant as her thought;
 That tangled beam of yellow sunlight, caught
 In dainty meshes of thin spider-lace,
 Is like her warmth of hospitable grace;
 The spreading branches of the tall palm-tree
 Are like her all-embracing charity.

What is she like? Would I had power to tell!
 Like to a sunset in its after-glow.
 When all the world is dusk and dark below,
 And wooded hills are clothed in misty shrouds,
 When quietly and still the waters flow,
 Then the long lines of light beneath the clouds
 Seem like a dream of sky beyond the skies:
 In that deep hush I feel the mysteries
 That hide within the shadows of her eyes,
 And deeper, deeper, deeper grows the spell
 As silent night above the dark earth broods,—
 That heavenly night wherein her soul doth dwell,—
 Calm night the mirror of her solemn moods.

TOPICS OF THE TIME.

The Purchase of Pictures: A Proposition.

THE art-life of New York is in the course of rapid development, but art-life in New York has always had its difficulties, which do not diminish. To these we wish to call attention, as also to a plan for mitigating them, though they can never be entirely obviated.

In the first place, pictures can never be reckoned among the necessities of life, nor even among its more common luxuries. The man who, in any way, becomes rich, and able to command luxuries, feels his way toward them along the grosser lines of appetite and taste. He understands horses and carriages, and clothing and a showy house. His æsthetic sense has had no cultivation, and fine pictures do not minister to his pleasure. He does not understand them. So it is that while pictures are regarded as luxuries, they do not come into the list of those which have first demand at the hand of wealth. So it is, in consequence, that while all the rest of the world may be prosperous, the artist may be starving in his studio. Nobody, perhaps, is to blame for this, because there is nothing in the wealth-winning processes of life to develop the love of pictures, or the power to judge them.

To buy pictures, one must have money; and to love pictures, so that they shall be a perennial source of pleasure, one must have an educated taste. Now there are a great many people, who have the money, and who are quite willing to spend it for pictures, if they can be sure that they shall get their money's worth. They know there is a great pleasure in pictures to those whose tastes are up to them, and they would like to win the capacity for them, and to own the pictures, the presence and influence of which are an educating power. There is a well-established conviction among them, also, that good pictures are a good investment, and that they grow more valuable as they grow older. The great difficulty lies in the matter of purchase. They have no confidence in their own judgment, and so they will not buy. Sometimes they go into an auction room, and are inveigled into bidding off some blazing piece of color, that was painted specially for unaccustomed eyes, and they learn in good time that they have been cheated.

The New York artists are not tradesmen—the best of them. They cannot advertise their skill, or their wares. They have no chance, like other men, of disposing of their service, or pushing their fortunes. They have no combination of interests through which to reach the great purchasing public. In some of the European cities and art-producing centers, the artists combine, and establish a gallery to which they send their pictures as fast as they produce them, and through their agent they are enabled to show and dispose of them. They have a most interesting gallery of this kind in Venice, as we happen to remember, supported by fees of admission;

and here every man goes who wishes to buy a new Venetian picture, or to put himself into communication with an artist. Mr. Moore's gallery, recently started here, is an approach to this kind of thing, but it is, after all, Mr. Moore's enterprise, and not the enterprise of the artists themselves. We hope it may abundantly succeed, because it cannot succeed without being of great advantage to the artists of the city.

In London, and other large towns, matters are managed on a different plan. There, when an artist has completed a picture, he carries it to a picture-dealer and sells it outright, and takes his money for it. Then his picture becomes a piece of merchandise, in the hands of a man who is at liberty to use all the machinery of persuasion that he would employ in the disposal of any other article of merchandise whatever. He can advertise, he can talk as the artist cannot, and he can and does sell his pictures. There are, of course, some painters who are sought after and who paint exclusively on commissions, but the great multitude sell to the dealers, precisely as an English novelist sells his novel to a publisher, relinquishing forever all right, title and interest in his manuscript. Now, we have some picture-dealers in New York, but unhappily the most of them are mainly interested in foreign pictures, which they buy for a comparatively small price, and sell for a large one. We have no fault to find with the enterprise. It is perfectly legitimate, but it works against the New York artists. A New York artist almost never sells a picture to a home dealer, until he has become so pinched with poverty that he is absolutely obliged to sell at a rate ruinously below the real value of his work. The dealer's interest being mainly in foreign work, and in keeping up the interest in foreign names, the home artist is always at a disadvantage.

It is in view of all the considerations that attach to the case that we propose an experiment, conceived in the interest of all concerned—the purchasers and the artists alike. Scattered over this wide country, there are almost numberless wealthy men and women who would like to purchase good pictures, if they could be assured of the quality of their purchases. We propose, therefore, through the good offices of the art-department of this magazine, to purchase pictures to order, for any part of the country. We will consider all wants that are intelligently expressed, carefully and conscientiously canvass and record all values, give letters of advice and counsel, send photographs of any desired picture, and transact all the business for a consideration which shall simply cover expenses, such expenses always being expressed or covered by the round price of any picture in question. Our patrons ought to know by this time that the men who preside over the art-department of this magazine understand their business, and are quite competent

to undertake and manage efficiently and intelligently the enterprise we propose.

To the artists of New York, we wish to say that, fully appreciating the many difficulties under which they labor—even some of the best of them—we have instituted this scheme in the sincerest friendship for them, and in return for that hearty interest they have manifested in the magazines of SCRIBNER & Co., which has contributed so much to their success. To the purchasers, or would-be purchasers, of pictures throughout the country, who cannot come to the city to buy for themselves, we promise intelligent and faithful representations, and the honorable dealing of a mercantile house long established and without reproach.

The Revision of the Scriptures.

It is now pretty definitely understood that, while it will take about three years more to complete the revision of the present accepted version of the Old Testament Scriptures, the New Testament is practically finished, and will make its appearance some time during the present year. Notwithstanding the fact that the Bible was never criticised or questioned so closely as it is in this day, there is a profound and wide-spread interest in the work undertaken by the revisers; and the appearance of no book during this century has been anticipated with so keen a concern as the Bible we are to receive at their hands. The Christian religion is a tremendous factor in human life and human history. The immortal hope of millions is bound up with it, and grows out of it. Christian morals leaven all the best civilizations of the race. Christian worship is the only pure and rational worship. It is spiritual, and is lifted toward a spiritual being. The Bible is the record and the revelation of this religion, and will remain the most interesting and important book in all literature.

For a good many years, that portion of the Christian public that speaks and reads the English language has been aware that its own version of the Scriptures is full of imperfections. Many passages offend the simplest principles of grammar, and many passages, because of the changes in the language, have lost their true meaning. Words that mean one thing in King James's time mean now quite another, and it has even come to be quite well understood that portions of the accepted text are of doubtful authenticity, in the lights that have been thrown upon them by modern scholarship. Men have been startled by strange translations and glosses in the marginal readings of their Bibles. The explanations of the text thus introduced have tended very powerfully to shake the public faith in the reliableness of the old version. If anything more were needed to uproot the public confidence, the ministers have furnished it abundantly from their pulpits. The phrases: "This passage would be better rendered by these words," or, "More correctly translated, this passage would read" so and so, have become stereotyped among pulpit utterances. The commentators and the preachers have destroyed the popular faith in the value of

the old version by their constant attempts to correct and to mend it.

We recently attended a parlor meeting of the American revisers, at the house of Hon. William E. Dodge, in this city, during which we became aware of what seemed to us the ignorance of these revisers touching the tremendous public interest that gathers around the work they have done, and are to do. It seemed to us that they did not understand the feeling of the public upon the matter at all; that they did not appreciate the interest with which the result of the work is regarded, nor the perfect confidence with which that result is awaited. It is the modesty that naturally attends true scholarship, we presume, which leads them to suppose that their work will be severely criticised—that it will disappoint many by its changes, and many others by its few and trivial alterations. And it may as well be stated just here that they are not to present the English world with a new version. It is simply to be the old version revised, freed from its errors, and possessing in every way the advantages of all the study and discovery of the two hundred and seventy years that have passed since 1610—the date of the issue of "King James's Bible." The old form of language, which has itself become sacred to the eyes, ears and hearts of Bible-loving people, is to be preserved.

We say that it seemed to us that the revisers at this meeting failed to appreciate the popular confidence with which the result of their work is awaited. We believe, from the feeling everywhere around us, that the result of this revision will be received with unquestioning confidence. The public understand that the revision will be the work of the best scholarship of two countries, selected and exercised upon a broad and catholic basis, and arriving at a result that is essentially unanimous. It is believed that these men know all there is known upon the subject which engages their attention; and the new revision will be received, in our opinion, without a question. Indeed, we doubt whether there is any divine living, outside of this circle of men, who can publicly undertake to criticise their work without danger to his own reputation. Of course, there will be great curiosity to see what kind of work the revised version will make of accepted doctrines and various sects. It is quite possible that certain proof-texts that have been used to uphold precious old dogmas, or instate and support sects, will be riddled; but we have no idea that the essential facts and doctrines recorded in the book will be changed. Indeed, we already have this assurance from the revisers themselves. Love to God and men will remain the beginning and end of religion, and obedience to law will be the whole of morality. The record of the life and death of Christ will be changed in no essential particular, and he will still remain, what he has always been, the central figure and the informing and inspiring force of the religion called by his name. If the men who have called themselves by other names get a tumble, who cares? But the great, undeniable fact that Bible-reading Christians, of all names, are waiting for the new revision with such interest that there is not one of them between

the Atlantic and Pacific Oceans who will not purchase one at the first opportunity, is full of grateful significance, alike honorable to themselves and to the self-sacrificing workers who have sustained, without money and without price, the long and arduous task of preparing a perfect Bible in the English language.

Industrial Education.

THERE are certain facts of current history which give great importance to the subject of industrial education. It is notorious, in the first place, that the old system of apprenticeship has almost entirely gone into disuse. How the American artisan gets the knowledge and skill which enable him to work at a trade, is not obvious. In one way or another he manages to do it; but the approach to a mechanical employment has practically ceased to be through an old-fashioned apprenticeship. Among the causes that have conspired to procure the abandonment of the old system, may first be mentioned the influence of common schools. Quarrel with the fact as we may, it cannot be successfully denied that the influence of common schools has been to unfit those subjected to their processes and social influences for the common employments of life. The lad who has made a successful beginning of the cultivation of his intellect, does not like the idea of getting a living by the skillful use of his muscles, in a mechanical employment. It does not account for everything to say that he gets above it. It is enough that he likes the line of intellectual development in which he finds himself, and has no taste for bodily labor. So he goes further, or, stopping altogether, seeks some light employment demanding his grade of culture, or tries to get his living by his wits. Mechanical employments are passing more and more into the hands of foreigners. General Armstrong, of the colored college at Hampton, in a recent search for blacksmiths' shops at the North where he might safely place a number of Indian lads, found no Americans to deal with. Every blacksmith was an Irishman.

If it is asked why there is not a universal effort made for the reinstatement of the apprentice-systems, we reply that there is a very ugly lion in the way. An item of news which has just gone the round of the papers states the case as it stands. A piano-maker complained that he could not get men enough to do his work, the reason being that his men belonged to a society that had taken upon itself to regulate the number of apprentices he could be permitted to instruct in the business. They had limited this number to one utterly insufficient to supply the demand, and he was powerless. They had even cut down the number recently, so that there was no way for him but to import his workmen, already instructed, from abroad. In brief, there is a conspiracy among society-men, all over the country, to keep American boys out of the useful trades; and industrial education is thus under the ban of an outrageous despotism which ought to be put down by the strong hand of the law. It is thus

seen that while the common school naturally turns the great multitude of its attendants away from manual employments, those who still feel inclined to enter upon them have no freedom to do so, because a great army of society-men stand firmly in the way, overruling employer and employed alike.

The public hardly needs to learn that the result of the indisposition and inability to learn trades among American boys is about as disastrous as can be imagined. It is found that in the prisons, almost universally, the number of criminals who never learned a trade to those who are skilled workmen is as six to one. The army of tramps who have infested the country for the last few years is largely composed of men who have had no industrial education whatever. These men, who beg at our doors, are mainly men who never learned a trade, and who can handle nothing but a shovel. A New York clergyman, possessing a large family of boys, recently declared from his pulpit that he intended that every lad of his family should learn some mechanical employment, by which, in an emergency, he could get a living. He was right. It is in the emergencies of life—it is when men find themselves helpless and without the power of earning money—that they slip into crime, and become the tenants of prisons and penitentiaries.

So the American people must, sooner or later, be driven to the establishment of industrial schools. To learn how to work skillfully with the hands must become a part of common education. Rich and poor alike should be taught how to work, for it is quite as likely that the rich will become poor as that some of the poor will become rich; and that is, and always must be, a poor education which fails to prepare a man to take care of himself and his dependents in life. We understand what to do with criminals. We confine them and set them to learning a trade, especially the young criminals. The reform schools never leave out the element of manual industry. Why is it not just as legitimate to teach the virtuous how to take care of themselves without crime as it is the vicious?

Indeed, there is no place where men can learn to work so well as in schools, where they can be taught the principles of mechanics. We visited a shop recently where hoisting apparatus is made,—“blocks” or “tackle,” as it is called—but there was not a man in the shop, from the master down, who could explain the principle and power of the pulley. They had learned their business of some routine mechanic who had no intelligence in the principles of his art, and they were obliged to confess to a stranger that they were ignorant of the nature of their work, and, consequently, without the power to make any improvement in it. Now, if the money spent in education really unfits the great majority for the work of life, or, rather, fails to fit them for work, why should we go further in this direction? There are practical difficulties in plenty, but the thing has already been successfully tried in more than one country, and this is an inventive nation. The cost is the real difficulty—the cost and the indifference of the public mind. We have

made a sort of god of our common school system. It is treason to speak a word against it. A man is regarded as a foe to education who expresses any doubt of the value of it. But we may as well open our eyes to the fact that in preparing men for the work of life, especially for that work depending upon manual skill, it is a hindrance and a failure. To learn to make a painted wagon is almost to cover the field of the mechanic arts. To draw a wagon upon paper in whole and in working parts, to build and finish the wood-work, to forge and file the iron work, to go through all the joinery of one

and the welding and adaptation of the other, to smooth and paint the surface, is to achieve a preparation for almost any trade, involving construction from similar materials. It is not so complicated and difficult a matter as one would at first suppose. We have agricultural schools of a high grade, and find the national account in them, but we need a great deal more, for the health and welfare of the youth of the nation—an industrial school in every ward of every city, and a similar school in every village, supported at the public expense.

HOME AND SOCIETY.

City Shopping for Country Friends.

WHAT is so dear to the heart of an American woman as a bargain? It would really seem that to make a very little money buy a great deal, without reference to any other expenditure involved, were now the "chief end" of woman. Listen to the bits of talk that float into your ear as you stem the tide of Broadway, or the main shopping street of any of our large cities. The burden of the conversation is always bargains, bargains, bargains. "What was the price of this?" or, "Where can this be bought cheapest?" or, again, "Isn't that lovely! I wonder how much it costs?"

This is only one of the petty ramifications of the commercial spirit, which, in excess, will eat the heart out of any nation, or of any nature. The spirit of trade, the dominant purpose of giving the least and getting the most, is not limited to our great business exchanges. It is all abroad, poisoning our spiritual atmosphere, tainting our social relations, weakening the springs of noble and disinterested action, and breeding a host of mean and petty vices in the individual. So far from being confined to our great cities, it appears to possess the homeopathic quality of gaining potency by subdivision, of growing stronger as it deals with more minute quantities.

Many country-people, who take the city papers, fairly gloat over the enticing advertisements—with prices attached—of "great sacrifices," "unexampled opportunity for buyers," etc., etc., etc. They seize the bait and walk into the trap—oh, wise country-people!—*by proxy*. And the poor proxy is called upon to make good the unprincipled promises of the tradesman.

To add to the trouble occasioned by these vicious advertisements, country-people have the most erroneous ideas in regard to city life. Every woman living in the country or in a small village knows by painful experience the burden of her own cares, and the exactions of her own duties. She has usually no conception of other cares as heavy, and other duties as absorbing, as her own, though entirely different from them. She is apt to fancy her city neighbor living a life of luxurious idleness, spending

her time in a round of pleasures; and to feel it rather a virtue to supply a motive to this aimless life. She does not take the trouble to inform herself about the state of the case before she passes judgment and acts upon it. She does not try to understand, or care to remember, that city life, while it enjoys certain immunities, entails peculiar duties and suffers myriads of interruptions; and that time, which is such a cheap commodity in the country, comes to be very precious in the hurry and bustle of city life.

There are cases where money to buy the bare necessities of life is hard to get, and when the only thing left to a woman is to make it do its very utmost. But such cases lie entirely outside the question at issue. I am not talking of the necessities of life, but of its luxuries. Possibly, a woman has the right to spend days and days in laborious bargain-seeking, if her time and energy are worth absolutely nothing to herself, or to anybody else. But when it comes to weighing against a few of our petty dollars other people's time, and strength, and comfort, the aspect of the matter changes. Nothing but necessity will redeem this from being a gross imposition.

I am living in a small country town. I want a new dress. I have something which I *could* wear, to be sure, but I want something new. It must be very pretty, suitable for the street, but not too plain or somber for a quiet dinner-party. It must be stylish, of course, and it must be cheap. I bethink me of some city friend, and feel sure she "wont mind." She goes out every day, and she can easily find just what I want in one of her afternoon strolls. I write, giving her the vaguest possible directions, only it must not be this, or that, or the other, and it must suit my style and complexion. While she is about it, will she not get me a pair of gloves to match, and a simple hat, with materials for trimming it, and any little new and pretty things for the neck. What a caressing tenderness a woman feels for her neck! I generously leave the decision, the responsibility, everything, to her taste. No, not quite everything: I limit her in the price; about that I am very particular. Per-

haps I send her a check to cover expenses with the order, but probably I say to myself, "No, she will not mind. I will send it to her when I know the exact amount. City people always have such sums about them."

But the question has another aspect, of which this innocent *I* is entirely unconscious, and which should be made clear.

The city friend accepts the commission, the first time cheerfully; after repeated experience, with a weary sigh. She spends days walking the muddy or dusty streets, trying to make the very indefinite directions about beauty, and style, and suitability harmonize with the extremely definite ones in regard to price. She finally concludes her task. The dress, with trimmings and cut-paper pattern, the hat with its numerous belongings, the gloves, neckwear, etc., are bought, and the results of all this matching, and selecting, and thinking, of these weary walks and squandered hours, come home in a number of paper parcels. But the end is not yet. A suitable box must be found; the house is ransacked in vain. Another trip—for who ever seriously and reasonably thought of the box till the last moment?—and a box is bought (an item not entered in the account). One whole morning is then devoted to packing it, nailing it up, marking it, and despatching it to its destination.

After all this labor my box arrives. I open it and pounce upon the small paper containing the account. My heart sinks!—I did not think it would be so much. I explore the hidden mysteries. Whatever my search may reveal, it is certain to be different from the vague, angelic raiment which has been floating on the confines of my fancy. I write, expressing my thanks, and perhaps, if I have not done it before, I send my check. But down in the bottom of my heart there is a reserve of dissatisfaction, which sounds out perfectly distinct above all my wordy thanks.

And my friend—does she feel as cordially my friend as ever when she has seen how mean, how inconsiderate, how ungrateful I am willing to be to save a few dollars of my money? There are agencies for the purchase of dresses and bonnets, of gloves and laces, where people are glad to do the work, and do it well, for a commission. Samples, catalogues, fashion-books, are always attainable, by which selections quite as good and satisfactory can be made, as by most friends at a distance. This mode has its disadvantages: it costs more, and one has to pay for the time used, instead of taking it from others.

A singular immunity from this sort of imposition, due to superior good fortune, wisdom, or ill-temper (I will not inquire too curiously which) makes it possible for the writer to speak impersonally, and therefore strongly, upon this growing vice among American women. It has been well and wisely said that quite as much of the evil in this world springs from women's vanity as from men's wickedness. And all other forms of this vanity pale before the growing and absorbing passion for dress. How many of the noble, and sweet, and gracious

things of life are yet to scorch up and shrivel in this baleful fire, in which so much has already perished?

S. B. H.

The Plague of Formal Calls.

IS IT not time that a protest should be made against the absurdity and unprofitableness of our custom of "paying calls?" To visit our friends for the sake of their companionship is one thing—a thing to which no social reformer, however parsimonious of time, would wish to put a limit. To visit those whom we think a more intimate acquaintance might make our friends is another thing, but equally wise. Visiting with such ends in view, however, implies choice, while the term I have quoted above implies a social obligation of the most binding character. A social dishonesty is certainly implied in the accusation that one has not "paid" the calls she "owes."

What is this custom, simply stated, and what solid grounds for its existence would remain did we once remove the venerable lumber of custom and tradition with which it is now securely propped? Simply stated, it is customary for a woman, who moves in any society whatever, alternately to visit and to receive visits from every woman with whom she wishes to keep up even the most formal acquaintance. It is a perpetually-recurring ceremony, for one visit "paid" means a return visit "owed," and so on forever. The purpose originally served by the custom is the distinction it enables us to draw between those we desire and those we do not desire to number among our acquaintances. But a ceremony which is, perhaps, in its simplest form quite indispensable, may at last grow, through senseless iteration, into an intolerable burden. A woman in a large city who would not drop entirely out of its social life, must keep hard at work at her Sisyphean task, made doubly onerous by the custom of "kettle drums," teas, and receptions. In a place like Washington, where political is added to social etiquette, the weight becomes almost unbearable. I heard a lady say once that she would never go back to Washington as a politician's wife, unless she were allowed to assume deep mourning for some fictitious friend. The only escape from the useless drudgery of "society" seemed to her to lie in a course that would cut her off from all its pleasures as well. In small towns the case is almost worse, for there one gets but meager compensation in social pleasures of any kind, and though the list is briefer, the names bring more constantly recurring obligations. These are debts which we must discharge, not even with hard-earned dollars, but with hours that are not to be regained or replaced by any effort, or at any cost. Is there any woman who would not rejoice if it were conceded that one visit paid to a new acquaintance, and one received in return, is enough. This much done, could we not wisely grant a woman perfect liberty to visit where she wished to go, and to stay away when she felt no contrary impulse? To be sure, if she be resolute, a woman may do these things to-day, but with most disagreeable consequences

to herself, because with much offense to others. Men, married men at least, have to a great extent freed themselves from thralldom in this matter. Their wives leave their cards and it is imputed to them for righteousness. And abroad, women, too, are allowed a very wide margin of this fictitious visiting. Does not the fact that "sending cards" is always hailed as a blessed relief, and often accepted as payment in full of one's debts, go far to prove that visiting itself will one day be "eliminated by natural selection," or will pass, at least, from an important organ in our social body to an atrophied survival.

M. G. VAN RENSSELAER.

General Principles of Cookery. IV. Frying and Broiling.

(CONCLUSION OF THE SERIES.)

BRILLAT-SAVARIN says, in an account of a conversation with his cook, "You are an excellent *potagiste* [*i. e.*, soup-maker], but are weak in the matter of frying." This weakness is common to so many cooks, and his directions are so clear and concise, that the quotation may be continued: "The chief element of success in frying is the *surprise*"—a very French and very graphic way of stating the fact. "To produce this, the fat must be sufficiently hot." When the meat is browned, "draw back the pan, that the cooking may not be too quick—that the juices, which have been sealed up, may in the slower process undergo the changes necessary to blend them and give them flavor."

Inexperienced cooks are apt to think that as soon as fat begins to bubble up it is hot enough, and that it will burn if left longer over the fire. Burnt fat would, of course, ruin everything, but the danger of burning is less than might be supposed. The fat should not only bubble but begin to smoke. A degree of heat less than this will cause potatoes to wilt, looking brown on one side and pallid on the other. Fish will be freckled with brown, with a gelatinous skin and greasy flesh. To test whether the fat is hot enough, when the "sizzling" has ceased for a minute or two, and the smoke begins to appear, drop a small square of bread into it; if the bread crisps and browns at once, put in your fish or cutlets immediately. If the bread causes only a quiet "sizzling," and does not brown in a minute or two, the fat is not hot enough.

Breaded chops, cutlets, etc., are often thought to be unattainable luxuries in families where inexperienced cooks are the rule. The result is too often, it is true, a greasy, piebald failure. Yet with finely-grated bread-crums, and with due attention to the surprise—that is, to having the fat very hot and an abundance of it—nothing is easier to do well. The bread-crums and egg come off, for one of three reasons: the fat is not hot enough, or there it not enough of it in the pan, or else the bread-crums are too coarse or uneven. If you have no bread stale enough to crumble finely, dry out some slices in a cool oven. Let the article to be

fried be perfectly clean and wiped dry; dip it in a mixture of two beaten eggs, a dessert-spoonful of oil and one of water; when the pan is ready and the fat hot enough, cover with bread-crums and plunge at once into the pan. There should be enough fat in the pan to cover the fish or chops. When cooked sufficiently—which can be determined, in the case of fish, by seeing if the flesh readily leaves the bone when a knife is inserted—take them up. If the fat has been hot enough and the article large, it will be of a fine brown color before it is thoroughly done, in which case, withdraw the pan from the fire to finish the cooking. Sift salt evenly over the fried meat or fish, and lay them for a minute on a sheet of paper before putting them on the napkin in which they are to be served.

Breaded veal-cutlets are improved by being well beaten, and cut into suitable pieces for serving, and by having the juice of lemon squeezed over them an hour or two before they are to be used.

Fried dishes should be garnished with parsley, which can be kept always at hand by potting a few roots in the fall and rearing as a kitchen window plant.

Fish dipped in milk, and then in flour, will fry a fine brown; this is the best substitute for eggs and crumbs.

Broiling is a favorite mode, with English and Americans, of dressing meat and fish. On the continent, where frying is so perfectly done as to be healthful, it is less popular. To broil well is considered a test of a cook's skill, and is undoubtedly a test of her carefulness.

A bright, hot fire, yet not too hot, a smooth, clean gridiron, and attention to one or two points, can scarcely fail to give good results. Chops or steaks should be neither salted nor peppered before they are broiled. If very lean, they will be better dipped in a little butter, which has been made hot in a plate. Turn the meat very soon after it has been put on the fire, and continue to turn frequently, until done. (The dampers should be always first turned back, that the odor may go up the chimney.) If there is any danger of burning, throw some salt on the fire and raise the gridiron.

Always have ready a hot dish, and a cover, also heated. For steaks or fish, have a good piece of butter, with pepper and salt in the dish.

Small birds should be strung on a skewer, not too closely together, first having been rubbed over with butter. They should be served on buttered toast.

Chickens are difficult to broil well, without either burning or leaving the joints raw. To avoid this, first break the bones slightly with a rolling-pin, that they may lay flat, and put the chickens in the oven for a short time. Then rub them over with butter, and broil until crisp and brown. Covering them with a saucepan-lid will also concentrate the heat and help to cook them thoroughly through, without burning; turn them frequently, and baste with a brush or feather dipped in warm butter. All broiled dishes should be served very hot.

Fish may be cooked in the same way, rubbing the bars of the gridiron with suet, or salt, to prevent the

skin sticking. Delicate fish must be broiled in paper. I will here give the two receipts for white sauce (or "melted butter," as English cooking books call it), alluded to in Paper No. 1. If a small quantity is desired, take two ounces of butter, mix with it a scant table-spoonful of flour. When mixed, put it into a thick saucepan, with a cup of warm milk or water. Then stir over the fire one way until the butter has dissolved, and with it the flour. Let it boil a minute or two, stirring constantly; add salt and white pepper, or cayenne. This is the best English method, and if the directions are carefully followed, the sauce will be rich and quite free from lumps.

The French make white sauce in the following

manner: Take two ounces of butter and a tea-spoonful of flour; melt the butter and flour together in a *thick*-bottomed saucepan; stir for a minute or two, until the flour is cooked, but do not allow it to change color. Then add a cup of water, and, when this boils, the beaten yolks of two eggs, the juice of half a lemon, and salt to taste. The yolks of the eggs must be *very carefully* added, allowing the sauce to go "off the boil" before doing so, and stirring for a full minute after they are added.

Sauce piquante, a great improvement to cutlets and chops, may be made by adding to this last sauce a very little onion, parsley, and a small pickled cucumber, all very finely chopped.

CATHERINE OWEN.

CULTURE AND PROGRESS.

Woolsey's "Communism and Socialism."*

THIS little book will go far to meet the need of a compact explanation and discussion of the history and theory of socialism. It is based upon articles originally published in "The Independent," with some new matter. The opening chapters treat of the definition and essence of socialism and communism. It is not to be denied that it is very difficult to define these two terms. It is especially difficult to find definitions which shall cover all the actual senses in which the terms have been employed in history. In regard to communism, this is simply impossible. For after the term had long been used to denote some variety of common possession of property, it was diverted to mean a theory of government, which is anti-national, and which erects the commune, or township, not simply into the all-important civil unit, but even into a kind of magical political institution. The communists of Paris, in 1871, were of this latter species. Its connection with the older forms of communism is very subtle, and the analysis of it leads to very deep insight into the nature and essence of the whole socialistic and communistic movement of our times. That movement, as a whole, is divided by two great divergent tendencies; the one to consolidation of a massive despotic "state;" the other to indefinite disintegration of the state, and anarchy. There is far more resemblance in these two political forms of civil society than at first appears, and they both, and they only, offer a possible field for the realization of socialistic and communistic theories; so that, spite of the divergence of the two tendencies, the socialists still maintain their reputation for logic and consistency in developing the propositions which they assume as postulates.

It seems to us, that Dr. Woolsey is not thoroughly

successful in so presenting the definition of socialism and communism as to be understood by a reader who has no previous information. He does not draw any distinction between the two, but treats them as almost convertible terms, which have the same essence, viz.: "the substitution of common, or public, or 'collective' property for private property." We should have said that there was a distinction to be noted between the two words, which was valuable for the elucidation and criticism of the theories proposed.

After describing briefly the communistic societies which have existed, and the Utopias which have been invented, the author goes on to describe the newest socialism of Germany. It is this part of the book which offers the greatest interest, for the English reader will not find elsewhere so convenient and correct a description of these newest theories. The theory of Carl Marx and that of Lasalle are examined, and a sort of review of Schaeffle's "Quintessence of Socialism," affords an opportunity for criticising some of the chief doctrines of the German socialists. Within the limits which the author observes, he has given a reasonably good account, albeit a meager one, of these interesting topics, and his criticisms are true and fair. In the chapter on Marx's theory, he discusses the doctrine that value is created by labor alone, and refutes it, by showing the function of the manager of industry, and the importance of the factor, wages and superintendence. We miss here, however, a paragraph showing the function of capital in production, and the necessity for its remuneration. This is really the element which the socialists overlook, or deny, and it is the point at issue between them and the economists. The best of the socialists affirm that at some future time men will reach a pitch of development so high that they will save capital, and give the gratuitous use of it to their fellow-men; also, that men of talent will give gratuitously to society the special services which their talents enable them to render, and will not

* Communism and Socialism in their History and Theory. A sketch. By Theodore D. Woolsey. New York: Charles Scribner's Sons. 1880.

profit by those talents, to make their fellow-men pay high prices for those services, as they now do. This is, of course, the last escape of those who cannot deny the facts of life, as it now is. It is, however, an escape into a Utopia, and only repeats once more one of the constant phenomena of socialistic speculation. The answer is that, if men ever reach that stage, they will know how to live in it, and will adjust their lives accordingly. The anticipation of such a state of things throws no light on *our* question, which is how we are to live now, in this world as it is now, and among these men whom we know. It would be pure folly, therefore, for us to abandon our question in order to find out how people are to live in the golden age to come, even if we should grant the truth of all the socialistic anticipations.

Dr. Woolsey closes with chapters on the relations of socialism to the family, to religion, and to the state, and on the probable future of socialism. He discusses these questions with great fairness, and without any declamation or denunciation against socialism. He does not feel so strongly as we do, that socialism is logically and inevitably at war with the family—and hitherto socialism has always been pitilessly logical. He seems to think that socialism owes its growth to the decline of religion, rather than that socialism has destroyed religion, although a reflex action of the latter kind is certain. As to the probable success of socialism, especially in the United States, he seems to entertain no great fear. In this he is certainly right. Socialism cannot have any strength here so long as the soil is held by a vast number of individuals in small portions, and so long as these individuals are of the "working-class."

Socialism is a disease of a state of civilization in which a true science of society scarcely exists, in which false notions of life, of the relation of the individual to the society and the state, are widespread, and in which all ranks are honey-combed by sentimental notions of what ought to be, and can be, in this world. Since Rousseau, a certain set of doctrines has been permeating modern society, which have no truth in history or fact at all, but which flatter human nature and are sure to be popular, because they make light of education, culture, capital, breeding, and all the excellences which, *being all very hard to get*, raise him who has them above him who has them not. The same doctrines teach, *per contra*, that the untrained man is the *norm*, and type, and standard, so that men, instead of being urged to seek the excellences, are encouraged to believe themselves superior, without them, to those who have them. Such is the outcome of the doctrine of equality, and, as it has spread, it has only grown more popular, has propagated more and more fallacies, and shifted more and more distinctly into a thirst and demand for (equal) enjoyment of material luxury. Socialism is an effort to gratify this thirst in some other way than by using it as an incentive to industry and economy. Obviously, there is no other way, unless it consists in taking away the means of material enjoyment from those who have produced and

saved them, and giving them to those who have not produced and saved them. Every step in that direction, is a step toward universal impoverishment and barbarism, and every step will have to be won by war. The socialists assume that their victory in that war is certain, but it is certain that they are entirely mistaken.

Gosse's "New Poems." *

MR. GOSSE, whose first volume was printed in 1873, displays a quality of steady growth that makes him prominent among the younger poets upon whom England shortly must depend for her harvest of song. His "Studies in Northern Literature," a critical prose work of genuine importance, recently was noticed in these pages, and its merit has been confirmed by a year of popular reference and approval. Certainly, no one of his lyrical associates has made a critical field so nearly his own, or put forth a book so marked by freshness, scholarship, and judicial taste. The production of such a work, with its acute analysis, elegant translations, and general mastery of its subject, could not fail to broaden and stimulate a poet's faculties, and we are not surprised to find, in Mr. Gosse's "New Poems," an advance upon both the first collection, entitled "On Viol and Flute," and the tragedy of "King Erik," which followed it.

His early poems, in common with other verse of the new school, showed an artistic sense of construction, and very plainly, also, his acquaintance with the Norse languages and legends; but in some places, an ultra-æsthetic tendency and a reflection of the cadences of other poets. The lyrics of the present collection have a more perfect finish, in that it is subordinate and natural,—while their thoughts and imagination are peculiar to himself. Where their atmosphere is not purely English, he seems to have left the Norseland for a season, and handles themes from the antique in a winning manner. It requires courage to offer more poetry of this kind at a time when readers have had a surfeit of classicism, and strength as a singer to treat such themes in an original manner. "The Gifts of the Muses," a sustained poem, which opens this volume, is as sweet a pastoral lyric as any we have had since the best of Matthew Arnold's, and not at all like Arnold's works. It is a poem to be relished by lovers of beauty, pure and simple. Few sonnets are better in their way than "The Tomb of Sophocles," or this other, which we select for quotation :

"THE PIPE-PLAYER.

"Cool and palm-shaded from the torrid heat,
The young brown tenor puts his singing by,
And sets the twin pipe to his lips, to try
Some air of bulrush-glooms where lovers meet;
O swart musician! time and fame are fleet,
Brief all delight, and youth's feet fain to fly!
Pipe on in peace! To-morrow must we die?
What matter, if our life to-day be sweet?
Soon, soon, the silver paper-reads that sigh
Along the Sacred River will repeat

* New Poems. By Edmund W. Gosse. London: C. Kegan Paul & Co. 1879.

The echo of the dark-stoled bearers' feet,
 Who carry you, with wailing, where must lie
 Your swathed and withered body, by-and-by,
 In perfumed darkness, with the grains of wheat."

Possibly Mr. Gosse has found his truest expression in those poems which, like the best modern landscapes, convey a profound suggestion or spiritually passionate sentiment in a subtle and ideal manner. Such are "By the River," "The Lover and the Water-lily," "Life in Death," and "The New Endymion." And how delicate these stanzas, from the poem "To My Daughter":

"Thou hast the colors of the Spring,
 The gold of king-cups triumphing,
 The blue of wood-bells wild;
 But winter thoughts thy spirit fill,
 And thou art wandering from us still,
 Too young to be our child.

"Yet have thy fleeting smiles confessed,
 Thou dear and much-desired guest,
 That home is near at last;
 Long lost in high, mysterious lands,
 Close by our door thy spirit stands,
 Its journey well-nigh past.

"Oh sweet, bewildered soul, I watch
 The fountains of thine eyes, to catch
 New fancies bubbling there,
 To feel our common light, and lose
 The flush of strange, ethereal hues
 Too dim for us to share!

"Fade, cold immortal lights, and make
 This creature human for my sake,
 Since I am naught but clay;
 An angel is too fine a thing
 To sit beside my chair and sing,
 And cheer my passing day.

"I smile, who could not smile, unless
 The air of rapt unconsciousness
 Passed, with the fading hours;
 I joy in every childish sign
 That proves the stranger less divine,
 And much more meekly ours."

In "The Loss of the *Eurydice*" Mr. Gosse memorializes a national tragedy in a virile and acceptable manner. In other poems of English life and feeling, he is fine and true. As a lyrical artist, his tone now has a clear, unmixed quality, and while his measures often are novel, they seem to fit his purpose and thought. It is a good thing for a poet to have reached the spot where he can perform what he attempts, as nearly as the actual ever can recast the ideal, and where his songs represent genuine moods, and are not written for effect. And it is not too much to say, that this is the point at which Mr. Gosse now stands.

"His Majesty, Myself." *

NO ONE of the numerous series of novels with which the country has been deluged of late contains as many good volumes of fiction as the "No Name." "It is essentially American in its scope and plays no unimportant part in the encouragement of light literature in America. We believe that it is generally known that the writer of "His Majesty, Myself" is Mr. W. M. Baker, to whom is likewise credited the Southern novel entitled "Colonel Dunwoddie,

Millionaire." Both have so strongly a feminine touch that the reader is in suspense for a long while, unable to decide whether the writer is a man or a woman; at the last one comes to the conclusion that certain phases of life could hardly have fallen under the notice of any but the most exceptional woman, and tardily acknowledges that they must have been written by a very exceptional man. Masculine and feminine thoughts and style very seldom co-exist in the same work. Another trait of these novels is the breadth of their politics. The writer might be a Southerner, who loves the region of his birth above all others and yet profoundly disagrees with the sectional spirit that still keeps the South from her normal development. Whether this be the actual case with the gentleman to whom these novels are assigned we do not know. At any rate, it is pleasant to think that they belong to the always increasing signs of liberality of thought among Southern citizens and of the near approach of the time when the South will do more than her share toward the development of a national literature and art. Mrs. Burnett, Cable, Lanier, and other Southerners of great merit, are the advance guard of a Southern army, before whose banners the North will have to capitulate, whether it likes or not. All that is needed is independent and free thought. Surely that cannot be far distant. When it comes, no quarter of the United States will prove more favorable to the growth of the highest forms of art.

"His Majesty, Myself" is a novel full of excellences and faults. It is animated and crowded with incidents, perhaps too crowded. It suffers from too open an effort to enlist fiction in the cause of scientific and moral theories. The egotism and robust self-complacency of Thirlmore, and the cold intellectuality of Peace Vandylke savor too much of a lesson against putting the flesh and the brain above the interests of the soul. In another, but kindlier way, that little Hercules of the brain, Guernsey, is a lesson against precociousness of wits. These are forced and unnatural characters, that require much more artful treatment than they get in order to make them acceptable to the reader. Stephen Trent and his lady love, Revel Vandylke, are in that respect better. The treatment of the college life of the two cousins, Thirlmore and Trent, shows an intimate acquaintance with either New Brunswick or Princeton; the characterization of college professors and odd people of a college town is able, but often overstrained. Satire there is, but very much held within bounds. When the sheriff comes to take away the fugitive slave, Pompey Courteous, and Stephen Trent goes to Doctor Stormworth to raise a subscription to purchase the freedom of Pompey, there is a chance for satire which the author does not improve. In his attacks on the sensational, popular-clergyman system he is bolder. In respect to the sectional differences resulting in the late war and the subsequent ill-feeling between the South and the rest of the country, his task is that of a peace-maker who shows the North that there is illiberality on the upper as well as the lower side of Mason and Dixon's line. It

* His Majesty, Myself. No Name Series. Boston: Roberts Brothers. 1880.

may seem that the faults found with the book are more numerous than the praises bestowed, but in truth it is quite interesting enough, good enough, strong enough, to stand criticism and only win additional readers thereby. It is enough to recognize the great ability of the writer; it would be wrong not to point out that the work is far from perfect and demands that he exercise increased care and depth in the next attempt.

Higginson's "Short Studies of American Authors."*

COLONEL HIGGINSON, in his critical capacity, displays a delicacy of touch which reminds one occasionally of Sainte-Beuve. His diminutive essays on Hawthorne, Poe, Thoreau, Howells, Helen Jackson and Henry James, Jr., derive more than half of their attractiveness from the clearness and epigrammatic brilliancy of his style. The same happy self-restraint and picturesque vigor which characterized in such an eminent degree Colonel Higginson's "Atlantic Essays" (and we cherish yet in affectionate remembrance "In a Wherry," and "On an old Latin Text-Book") are also apparent in the present volume. In addition to this, there are in the first three essays a few personal reminiscences which, trifling as they seem, nevertheless cannot fail to make a vivid impression upon the reader. Hawthorne, wheeling his baby son in a little wagon along the Concord Road, or, unconsciously overawing a club of literary *dilettanti* by his Olympian presence; Poe reciting his poem, "Al Araaf," in a thin, tremulous voice, before the Boston Lyceum, and gradually becoming attuned to the spirit of his song until his audience sits breathless and hushed; Thoreau, carrying the returned edition of his book, "A Week on the Concord and Merrimack Rivers" (consisting of seven hundred and six copies), up into his garret, and humorously consoling himself for his unpopularity by the philosophical reflection that he now has a library of nearly nine hundred volumes, more than seven hundred of which he himself has written; all these situations, even though a biographer might deem them of small account, are charming from their very commonplaceness, and engrave themselves indelibly on the memory.

In his criticism of his three contemporaries, the author is evidently bent upon doing justice, which, in the case of three such agreeable writers, must be an agreeable task. Nevertheless, we feel inclined to insert a parenthetical, and very modest, interrogation mark after some of his more daring judgments. In speaking, for instance, of Mrs. Helen Jackson's poem, "Spinning," he remarks: "No finer symbolic picture of life *has ever been framed.*" Is not this a little hyperbolic? We approximately agree with Colonel Higginson in his high estimate of "H. H.'s" poems, but we are obliged to take exception to some of his expressed and implied superlatives. Again, in speaking of Henry James, Jr., the

author complains that in his critical essay on "Tourguéneff" he makes no mention of the latter's masterpiece "Terres Vierges"; but Mr. James's essay appeared first in the "North American Review," for April, 1874, and "Terres Vierges" was published, in 1876, in Russia, and translated in 1877. He might, perhaps, when he reprinted his fugitive papers in his volume "French Poets and Novelists," have taken note of his master's latest work; but this would probably have involved a reconstruction of the whole essay.

Colonel Higginson's analysis of the literary character of Henry James, Jr., and, especially, of his limitations, is every way admirable; so, also, is the little epigram which characterizes Mr. Howells as a writer of "inter-oceanic episodes," in contradistinction to Mr. James, who writes "international episodes."

Linton's "Hints on Wood-Engraving."*

THERE are few of those who are generally classed as Radicals who do not reserve to themselves one or two points upon which they are stoutly conservative. These points are apt to be matters of opinion, of long indoctrination, and do not affect the general temper of the man, which more likely is brought to the advocacy of such conservatism with increased intensity. Thirty years ago, if one had been asked to point out the typical radical in English politics, he would have had far to search among the ruins of the Chartist movement to find one who would better answer to the definition than William James Linton. To-day, if one desires to find the typical conservative in wood-engraving, who would stifle experiment in the embryo, it is to Mr. Linton that he must turn. The luridness of 1848, to which Mr. Linton contributed no little sulphur and vitriol, is still seen flashing out in his "Hints on Wood-Engraving"—chiefly reflected in a type of speech which it has taken years of pamphleteering and political verse-making to acquire. Mr. Linton is not a lucid or a savory writer, and he shows himself prone to that most common of the foibles of debate: the accounting, on mercenary grounds, for a difference of opinion that attacks one's vanity or transcends his experience; but, for all that, he is a man of convictions and knowledge of engraving, whose arguments are not to be lost sight of in the dust of personalities, or forgotten in the laugh which follows his grimmest wit.

We shall be the last to deny Mr. Linton's technical knowledge, as we were the first to recognize it by soliciting from him an expression of his views on wood-engraving. In the June number of this magazine for the year 1878, in the article "Is the Wood-Engraver an Artist?" will be found his peculiar theories as to the liberties which an engraver should be permitted to take with a design. There, unobscured by cross-(or *cross*) references of any sort, is the simon-pure doctrine of Mr. Lin-

* Short Studies of American Authors. By Thomas Wentworth Higginson. Boston: Lee & Shepard. 1880.

* Some Practical Hints on Wood-Engraving. For the Instruction of Reviewers and the Public. By W. J. Linton. Boston: Lee & Shepard.

ton's school of engraving, against which is pitted the practice of nearly every engraver who has contributed to give American work its growing fame. Since the publication of that paper there has been unremitting discussion of the engraver's status and function, showing a remarkable interest in the subject, both among engravers and the public. It must, however, be said of Mr. Linton's later contributions, that they have somehow given out "more heat than light." It is to be regretted that in the present volume he has, for a second time, missed his opportunity of making a treatise which might stand, once for all, as a text-book of his subject.

The main point of difference between the old and the new schools, as they have been called, concerns the limits and the function of wood-engraving. Here Mr. Linton's conservatism is apparent. He would have nothing called wood-engraving that is not done mainly in "pure line," as it is called, and would permit no progressiveness. The new school, on the contrary, is intent upon experiments with new methods of a less conventional kind. Between the two, this magazine, though it originated the experiments, has never discriminated. It has never said "We will have no pure line," or, "We will have nothing but pure line," but has left the engraver free from dictation, and has tried to judge his work on its merits. ("The end will justify the means," says Mr. Linton, p. 83.) Where we have liked the new style, it has not been because of the technique, but of the results. Where we have disliked Mr. Linton's own work, it was not on the score of pure line, but because, in spite of his masterly and enviable freedom with the graver, the result is weak and characterless. Whether or not this result is largely owing to the method, remains to be determined. The very men whose experiments Mr. Linton decries may yet prove that, even with his methods, better results are attainable than his school has yet produced.

This difference of opinion as to the limits of wood-engraving finds its battle-ground chiefly on the question of the use of photography—a question quite apart from the intrinsic value of the photograph as a work of art. The artists, and most of the engravers, prefer the results of its use, while Mr. Linton will have none of it, and declines to engrave pictures so transferred to the block. If an artist cannot draw upon the wood, his contributions, however beautiful, must be declined, or else given to a middleman to be redrawn upon the block. This was the old style, and as there were few (and there are now fewer) draughtsmen of ability who both *can* and *will* devote themselves to the transfer of others' work, the monotony of the publications which employ the middleman is great, since the individuality of the artist's style is usually lost in transit. With the use of photography, on the contrary, has come a variety of individuality in the cuts. Whatever has been the faults of the photograph, it has preserved the original sketch better than the middleman. The photograph is often said to be mechanical, but we do not hear such an objection to the

printing press? It is the *multiplication* of mechanism which is really objectionable—the increase in the number of removes from the original touch of the artist. But if a camera reproduce a picture better than the pencil of a commonplace draughtsman, which is the more mechanical? To express the problems broadly in general equation, we would have:

The painter—the poor draughtsman—engraver of the old school = monotony and commonplace.

The painter+photography+engraver of the new school = variety and beauty.

Nor, in saying this, do we discourage drawing on the wood. Many of our drawings continue to be so made, and we are now only speaking of utilizing for popular enjoyment the work of those who cannot, and will not, draw in that way.

Intimately connected with this subject of photography is the question whether it is to be permitted (!) to wood-engravers to imitate the feeling of other processes—as etching, charcoal-drawing, *gouache*—for without the use of photography these effects would not be attainable. One would think, to read Mr. Linton's book, that there is some sly and subtle moral lapse in "imitation" by wood-engraving, similar to the affectations of a flunky, and that the original drawing was, after all, a mere suggestion or point of departure for the engraver. Are our musicians, then, devoid of common honesty in following a score of Handel or Beethoven? Not so have American engravers learned to look upon the function of their art. All they ask is, that their work shall be judged not by *a priori* objection as to method, but upon its results. When Mr. Linton decries the attempts to reproduce the feeling of a crayon or charcoal drawing, as "deceptions," and then confesses that he can see nothing like crayon or charcoal in them (*i. e.*, that they are deceptions which do not deceive), he has simply left himself a wide space through which to proceed to the consideration of other topics. To be sure, these effects are not adapted to the treatment of every subject, and there must be discrimination in the use of them, and discrimination is aided by experiment—against which, however, Mr. Linton closes the portals of Art with a bang. We must look to the past, he says, virtually, and not to the future, for the best wood-engravers. Is it, then, such a daring expectation to look for some advance in things beyond our horizon? Are there to be no Bewicks in the future?—no similar combinations, in mankind, of the inspiration and culture that produced Raphael and Titian? Let him say so who has the sublime egotism to believe it.

The truth is, that never was there more progress, more activity of thought, or more noble rivalry among engravers, than now, in America. The public standard, too, has been fixed so high, that it is no longer satisfied with old methods of draughtsmanship or engraving. Out of this have already come many masterpieces of graphic art, and we are on the high road to even better work than that which has won us fame abroad. The future of wood-engraving rests with both artists and engravers. Artists have much to learn about drawing for pop-

ular publications, so that their methods may not impede the interpretation of their conceptions by engraver or printer. As for engravers, amid all the popular interest now gathering around their art, they cannot do themselves or their country better service, than by bearing in mind this one of Mr. Linton's many admirable sayings: "The engraver is an artist, only so far as every line he cuts has intention of representing something."

Herbert H. Smith's "Brazil."*

MANY readers of Mr. Herbert H. Smith's valuable papers on Brazil, published in these pages, will be glad to find them in permanent form, increased by several new chapters, which have been added in preparing the work for the press. These additions, with the radical revisions made in the original work, have so modified its character, that it may be said to be a new production.

Mr. Smith enjoyed peculiar facilities for the task which he undertook, and which he has performed with boyish enthusiasm. In 1870, in company with Professor Hart, who was guide, philosopher, and friend, he went to the Amazons. Fascinated by the glorious charm of the region through which the mighty river flows, the young traveler, after his return to the United States, was drawn back to South America, and in 1874 took charge of an exploring expedition sent to the northern tributaries of the Amazons and the Tapajos, under the direction of Professor Hart, then at the head of the Brazilian geological commission. In this work a year was spent, and a four months' residence in Rio de Janeiro completed the author's sojourn in South America, for that time. Subsequently, in the employ of this magazine, Mr. Smith again returned to Brazil making two trips through the wonderful country which he so well described for our readers. Very admirably, too, do the drawings by Mr. J. Wells Champney supplement the author's description. Artist and author traveled in intimate companionship, and the sketches of the former give the reader a vivid idea of the picturesque region through which the party made their devious way.

Mr. Smith's plan involved an exhaustive work on that part of Brazil which he visited. Perhaps it would have been better for what we may call the "popularity" of the book, if he had undertaken to be less thorough. If, here and there, he has been too minute in the description of minor matters, he has never failed to give us the broader view which we need for a full understanding of the regions through which he has taken us in imagination. He is an interested traveler, and contrives to interest his reader in all that passes under his observation; and he sees everything, even the trifling things which would have escaped him in more familiar regions. One of the most valuable portions of the book is its accurate commercial data. If the commerce between the United States and Brazil shall

ever rise to the proportions which it is possible of attaining, it will be largely through the circulation of such information as that of which Mr. Smith makes much account in his book.

The School Experiment at Quincy, Massachusetts.*

In 1873, Mr. Charles Francis Adams, Jr., and his colleagues of the Quincy school committee, found that the pupils under their supervision, after ten years teaching, "could neither write with facility, nor read fluently." The school system had fallen into a rut. A multiplicity of studies had been taught, but little had been learned. In Mr. Adams's forcible but exaggerated phrase, "it was all smaller, venerated and cram." The town's money was wasted, and the schools were only half doing their work, or not doing it at all. This must be changed, of course, and the first thing was to employ a superintendent of the town schools, who could give time, and devote special training to the working out of a new method. A Mr. Parker was found, whom Mr. Adams describes as "a self-educated and self-made man, with all the defects, as well as the virtues, of men of that class," and he has now been for nearly five years reforming the Quincy schools. His specialty was primary instruction; he introduced a method of learning to read by sounds and object-lessons, without acquiring the A, B, C, by name; so that, as Mr. Adams says, not a child in the schools, though reading fluently, "could repeat its letters, or even knew their names, unless, perchance, to the teacher's increased trouble, they had been taught them at home." This, of itself, is common enough in American schools, and so, no doubt, are the other methods of object-teaching and practice in reading at sight and writing off-hand, which Mr. Parker employs. But he seems to have combined novelty and variety with common sense, in his system, to a very uncommon extent. Under the old system the seven studies which were considered elementary had been taught separately. Under the new, the studies are reduced to "the three R's"—reading, writing, and arithmetic—and, in teaching these the teacher includes, to a considerable degree, all the others.

"The old reader having disappeared, the teacher was at liberty to put in the hands of the class geographies, or histories, or magazine articles, and, having read them first, the scholars might write of them afterward, to show that they understood them. Their attention was thus secured, and, the pen being continually in the hand, they wrote as readily as they spoke, and spelling came with practice."

Mr. Adams says of the results in geography:

"Go, to-day, into the Quincy schools, and in a few moments two or three young children, standing about an earth-board and handling a little heap of moistened clay, will shape out for you a continent, with its mountains, rivers, depressions, and coast indentations, designating upon it the principal cities,

* Brazil. The Amazons and the Coast. By Herbert H. Smith. Illustrated from sketches by J. Wells Champney, and B. Wiegant. New York: Charles Scribner's Sons. 1879. Pp. 644.

* The New Departure in the Common Schools of Quincy, and Other Papers on Educational Topics. By Charles F. Adams, Jr. Boston: Estes & Lauriat. 1879.

and giving a general idea of its geographical peculiarities."

The secret of Mr. Parker's success—for he has been very successful—is, perhaps, not the details of his method, but the spirit in which it is applied. Mr. Adams says, "The essence of the new system was, that there was no system about it; it was marked throughout by intense individuality." This individuality has made itself felt in all the operations of the Quincy schools, and has attracted the attention of educators all over the country. In order to test its value, the Quincy experiment has lately been subjected to a strict comparison with the school systems of the other twenty-two towns in Norfolk County, Massachusetts, by an examiner sent out by the Board of Education in that State. The result appears in the report of that Board for

1879, just issued from the press in Boston. The averages of the Quincy school, marked upon a simple scale of so much percentage of all the questions answered correctly, are found to be considerably better than those of any other town in the county. It is one of the two largest towns in Norfolk, having a population now of nearly 10,000, while the whole county falls short of 100,000. The experiment has not been made on a large scale, therefore; but it has found its way, as we have said, into the Boston primary schools, where children are taught by the myriad and is justifying itself there. This method has been long practiced, in some of its details, in the schools of St. Louis, and doubtless elsewhere. It is worth remarking, perhaps, that the cost of this system in the Quincy schools is one-fifth less than that of the old text-book plan.

COMMUNICATIONS.

"Edison's Electric Light."—A Reply.

No. 3 MERCER STREET, N. Y.,
JANUARY 26th, 1880.

EDITOR OF SCRIBNER'S MONTHLY.

SIR:—The last (February) number of your magazine contains an article headed "Edison's Electric Light," by Francis R. Upton (Mr. Edison's Mathematician), and also headed with a letter from Mr. Edison, making himself responsible for the statements therein contained.

This authoritative article contains a statement implying ignorance on the part of other workers in electric lighting by incandescence, and ignorance, or worse than ignorance, on the part of the United States Patent Office; it also contains a misstatement in regard to Mr. Sawyer and myself, which I cannot, in justice to the company I represent, nor to myself, allow to pass without reply. It is as follows:

"In 1849 Despretz describes a series of experiments on sticks of incandescent carbon which were sealed in a glass globe, the air being exhausted, or nitrogen substituted for it. He used several ingenious methods for holding the carbon—patented within the last few years.

"So completely had the mode of lighting by an incandescent solid been forgotten, that in 1873 a medal was bestowed by the St. Petersburg Academy on Lodyguine for its supposed discovery, and letters-patent were granted to Sawyer and Mann for a stick of carbon rendered incandescent in nitrogen. No successful light by incandescence had, however, been produced when Mr. Edison began his experiments."

No patent was ever granted to Sawyer and Mann for a "stick of carbon rendered incandescent in nitrogen." Very much, however, of what Mr. Edison claims in your article to be his invention was patented by Sawyer and Mann long before Mr. Edison commenced working on electric lighting, and much also has been since patented by us. The English patent of King, agent of Starr, No. 10,919, November 4, 1845, the inventions of Staite and Petrie, Lodyguine, Konn, Kosloff, Fontaine and Boulligine, and the discoveries of Jobart, announced to the French Academy by M. de Changy,—would have precluded the issuing of any such patent without fraud or ignorance on the part of the Patent Office examiners. It is equally untrue that "no suc-

cessful light by incandescence had been produced when Mr. Edison began his experiments." Several as successful as Mr. Edison's appears to be, including those of Lodyguine, King, Jobart and Kosloff, had been produced and put in use by the inventors above named, and I claim that, before Mr. Edison can render his lamp a success, he must resort to still more of the inventions patented by Sawyer and Mann. Before Mr. Edison commenced the study of electric lighting, Mr. Sawyer and I had in use a large number of lamps with horse-shoe or circular-shaped carbons, one of which is now in the Patent Office, and several others of which, ready for use, are still in the possession of our company. The system of distribution illustrated in your article was patented by Sawyer and Mann, and put in use long before Mr. Edison commenced the study of lighting (as per his statement of time). You will see it illustrated in the "Scientific American," last of September or first of October, 1878. Its application to electric lighting was certainly original with Mr. Sawyer and myself, and I have never been able to find that any one prior to us had used it for the purposes to which we applied it. By its use the electrical resistance of the circuit is diminished as the number of lamps is increased. The lighting of a lamp by reducing the resistance exterior to the generator, telegraphs a demand for more current, which is enforced by the automatic action of the steam regulator or other regulator of power. The extinguishment of a lamp and cutting it out of circuit increases the resistance, thereby telegraphing for less current, which command is carried out by like simple means, so that, to a considerable degree, it is an automatic system of regulation by which only so much current is sent as is at any time required by the lamps in actual use. The use of the electro-magnet, which you also illustrate as a kind of safety valve and regulator for the incandescent lamps, was also patented by us about the same time.

Very respectfully yours,
ALBON MANN, Vice-President
Electro-Dynamic Light Co.

THE WORLD'S WORK.

A New Theater.

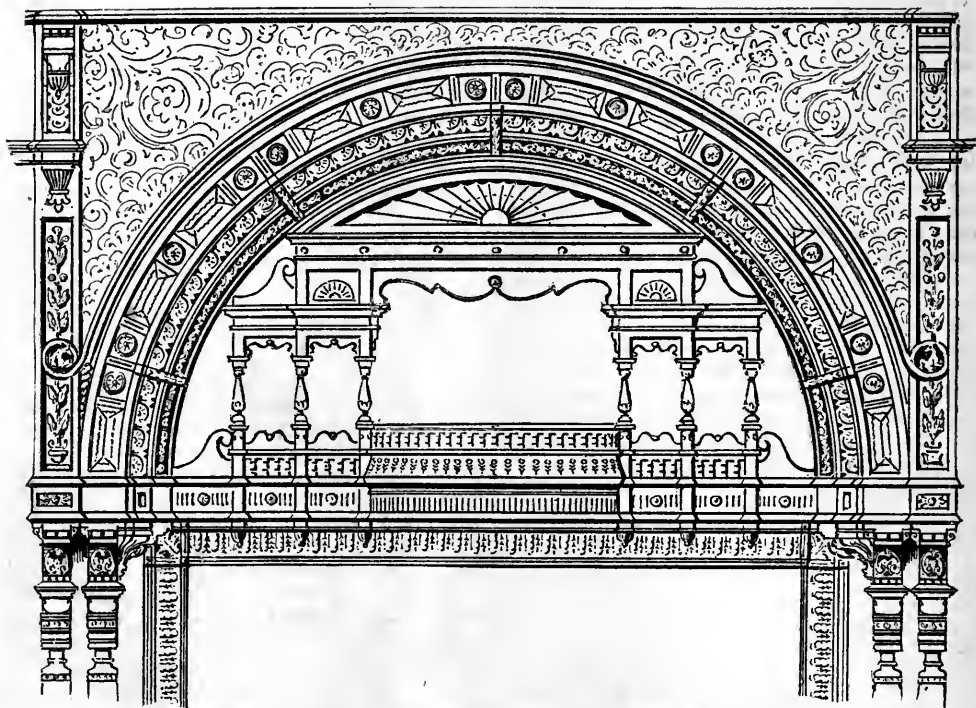

DIAGRAM SHOWING NOVEL ARRANGEMENT OF ORCHESTRA OVER DROP CURTAIN, MADISON SQUARE THEATER.

A NEW theater, recently erected in this city (The Madison Square), presents some features of novelty and interest to architects, engineers, and the general reader, on account of the peculiar methods employed in lighting, heating, and ventilating the building, and in arranging the seats for the audience. The building originally contained two halls, one above the other, an attic and a basement, and in turning it into a theater, all the floors were removed, leaving only the walls, and roof, and the iron stairways, and fireproof corridors, next the street. The rear half of the basement was then excavated to a depth of 9.75 meters (32 feet) below the street. A brick wall was then erected, dividing the building into two parts, the rear portion forming the stage, and the front and larger portion making the auditorium. In this wall was opened the proscenium arch, reaching from the basement, half-way to the roof. The main floor was then laid on iron beams and brick arches, and on an incline from the level of the street to about the center of the arch, leaving a deep basement below, and making the curtain opening above. The basement is therefore on two levels, the front part about 3.05 meters (10 feet) deep, and designed for the boilers and engines, and the deep excavation, making the pit into which sinks the movable stage, recently described in this depart-

ment, and also making a fire-proof store-room for scenery and properties. Above the first floor, and supported on iron columns, is a very deep gallery, coming close down to the stage, and above this is a second, but quite narrow gallery. The floor and two galleries seat about 1,000 people, and make the first and most noticeable departure from the conventional method of erecting buildings designed to seat a large number of people. The floor has a uniform slope, but each row of seats is on its own level, and raised about 11.5 c. m. above the row in front. The gallery is still more steep, and, in place of curving in the usual horse-shoe, it is twice broken in outline and in pitch. The center is nearly a half circle, and then comes a break, and the sides are curved twice. At the break in outline the pitch is lowered abruptly, so that the seats at the side next the stage are much lower than at the back, and giving a clear view from every part of the gallery. The second gallery merely extends across the back, following, in a modified degree, the curve of the first gallery. The entrances to the two galleries are placed on different levels, so that the sides, which are the lowest parts, are reached from a lower floor, the center having a higher entrance. Each row of seats in the center of the first gallery stands on its own level, there being no side-

ways pitch to the seats, as in the common horse-shoe gallery. By the break in the level, each circle is also divided into short groups of seats on different levels, and all the seats face the stage as nearly in a right line as possible, and each seat has a clear, unobstructed view, not only in front, but at the sides. By this arrangement the audience is brought closer together, giving a more social aspect to the house, and giving it more the appearance of a parlor than a theater. The seats on the lower floor come close down to the edge of the stage and the curtain, and in place of the usual pit for the orchestra is a narrow shelf designed to be filled with plants. For operatic performances, however, this can be removed, and room be made for the orchestra in the usual position. The stage is level and quite low, so that the entire audience looks down upon the stage from a higher level. The curtain opening is square, and framed in wood-work, elaborately carved, and flanked by wooden columns supporting the arch that springs above the curtain opening. Above the stage, and under the proscenium arch, is a hanging balcony, projecting slightly from the arch, and designed for the orchestra. This feature of the theater presents several advantages. The picture on the stage is not marred by the presence in the immediate foreground of a number of musicians, who are neither performers (as far as the stage picture is concerned) nor a part of the audience. By placing them above the stage, the music is

heard quite as well as below, and, at the same time, the musicians do not intrude on the stage or audience. The proscenium boxes, on each side of the stage, are kept well back from the front and out of the line of sight from all the seats. There are four boxes, two on each side, the upper pair being open at the top. The first of our sketches shows the orchestral balcony, and the second gives an excellent idea of the position of the boxes in regard to the stage, and also indicates the curve of the gallery and the treatment of the columns in connection with the arch and the ceiling. The two boxes are similar in general design, though differing in artistic detail. It will be observed that the audience is brought down close to the stage, as to a great picture, and that

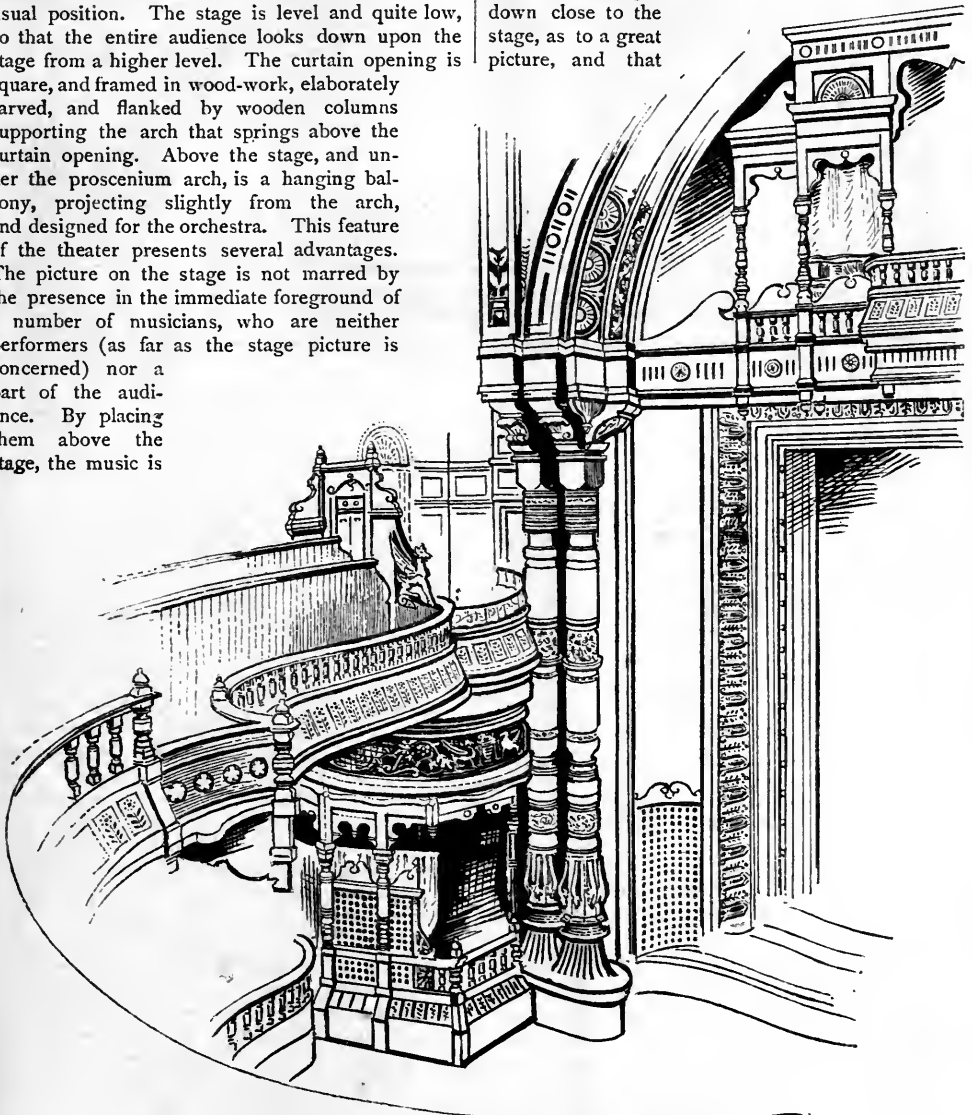

GALLERY AND PROSCENIUM BOX, MADISON SQUARE THEATER.

there are no intrusive groups of people at the sides who care more to be seen than to see. On either side of the stage behind the boxes are two wells. One of these contains a circular stairway, connecting the basement with all the different galleries of the stage and giving access to the orchestral balcony. The other well is a downcast shaft extending from the roof to the basement. At the bottom, the shaft connects with a horizontal shaft extending to the front of the basement. A suction-fan 2.13 m. (7 feet) in diameter, and driven by a special steam-engine, is placed in the shaft at this point, and the shaft then divides into four branches, each leading to an air-box supplied with steam radiators. From these air-boxes small tin pipes lead to openings in the floor overhead, under each row of seats. By placing the radiators in groups in different parts of the building, the engineer has perfect control of the heating, and can keep all parts at the same temperature. In winter, steam is to be admitted to the radiators and the fan set in motion, drawing fresh air from the roof and sending it, in a great number of fine streams and thoroughly warmed, into the house. A branch is taken from the air-shaft before it reaches the radiators, for the purpose of sending pure cold air into the theater through openings in the ceiling under the galleries. In summer, the fan is to draw the air over ice, or through a shower of cold water, thus sending cooled fresh air into the building. Ample ventilators are supplied for removing the vitiated air pressed out by the air driven in by the fan, openings being provided, not only in the ceiling, but under the galleries. On lighting the building, attention has also been paid to ventilation, all the gas lamps being placed in the ceiling or walls, inclosed with glass, and provided with separate ventilation for each lamp. In lighting the stage the plan has been tried of placing lights at the top and sides, outside the curtain. These lights are almost inclosed and are provided with separate chimneys. The design of this is to cor-

rect the shadows cast by foot-lights, and to illuminate the stage from the front, very much as pictures are lighted in picture galleries. These lights are inclosed in a fire-proof niche, at the sides, and under the orchestral balcony, and are not visible to the audience. The large picture shows the niche for these lights in part. The front of the stage is only slightly advanced before the curtain, and to provide for the appearance of the performers, when called before the curtain, doors are made in the frame behind the columns, and they step out before the audience upon the narrow platform. This door and audience are also shown in the large picture. This arrangement obviates all disturbance of the illusion by raising the curtain or pulling it one side. In the audience-room, great care has been taken to preserve the acoustic qualities of the room by making, as far as possible, all the corners at the sides, and under the galleries, curved. The orchestra is also backed by a wooden sounding-board, or shell, designed to reflect the sound into the house. Behind the curtain, the most novel feature is the moving and elevating stage. The four steel ropes, designed to lift the stage by the four corners, are carried over a drum at the roof and are joined together by a heavy yoke that serves to distribute the strain equally. This yoke also carries counter-weights in addition to the four independent counter-weights, already described. In actual operation, the new stage works swiftly and in silence. The decoration of the theater is of the most elaborate and artistic kind—wood-carving being very freely used about the proscenium arch, the boxes and the galleries, the designs being nowhere alike. The theater, though small, may be regarded as a most interesting experiment, that may in time be the means of greatly modifying the design of our public halls and places of meeting. Much might be said of the art work, but it does not properly come in this department. The pictures will, however, give a suggestion of its general character.

 BRIC-À-BRAC.

Verses by Irwin Russell.

REV. HENRY'S WAR-SONG.

Who's gwine to fight in de battle, in de battle?
 Who's gwine to march wid de army ob de King?
 Listen at de drums, how dey rattle, rattle, rattle:
 Hark to de bullets, how dey sing!
 Close up! saints, in de center!
 Fall in! sinnahs, on de flanks;
 'Tention! right dress! eyes front! steady!—
 All stand quiet in de ranks.

Dat's right, men! keep a-standin', keep a-standin'—
 Not a bit o' danger ob an inimy behin':
 De ahmy's at de front, an' ouah General Com-
 mandin'

Has got out a pow'ful pickit-line!
 Wait for your orders till dey come, den;
 Keep up patience—rendah thanks
 Dat you has nuffin' for to do—unless it's
 suffin'
 To stand up waitin' in de ranks.

'Twont be so long 'fore de orders, 'fore de orders—
 Soon we'll be gittin' 'em—de orders to advance;
 Den, eb'ry man in de column to his duty;
 Show what's de value ob de chance!
 Fight! an' we'll oberturn de debbil!
 Fight! an' we'll hab de country's thanks!
 An' all 'll git a pension an' a honorable
 mention,
 What stood up steady in de ranks!

THE ROMAUNT OF SIR KUSS.

(A brave ballad of a knight of prowess and his lady passing fair, wherein the clerk hath embodied choice store of morais, not developed unto expression, but left, as it were, in the raw, to be worked up at the reader's good pleasure.)

'Tis of a fair young damsel,
Who to the gate did go
To see the grand procession
Of a "highly moral show."
The elephants advancing,
And the spotted horses prancing,
Cheered her soul and made her merry—
Laughed she long and loudly, very,
At the clown and "January."

"Of a swain I do bethink me,"
To herself observed the maid,
"Who shall take me there, and treat me
To the 'ice-cool lemonade.'
For methinks this circus truly
Hath been organized but newly;
And holds the proud position
Of a model exposition—
'Six shows for one admission.'"

Came the twilight, came the starlight,
Came the glow-worm in the grass;
And, in his coat of darkness,
Came the lover of the lass.
To the show did he attend her,
And one dollar, legal tender,
For the tickets did he squander,
That within they twain might wander,
Crying, "See that monkey yonder!"

Soon they sought "the next pavilion,"
And he firmly held her hand
While they sat on high, and hearkened
To the music by the band;
And the ladies, knights and pages
Reproduced the Middle Ages
In a "grahnd, imposing enterry
Of nobilitee and gentry,
Olly mody 'leventh centerry."

As leader of the pageant
There rode a gallant knight,
Imposing in appearance
And air—Sir Kuss he hight—
Who, very knightly, daily
Rode foremost in the *mêlée*.
By natural selection,
Our heroine's affection
Went out in his direction.

He did not ring the bell that
Hung in her father's hall,
But rigged him a rope-ladder
And "passed it over all;"
And down upon the stoop was
The spot where all the troupe was,
And there the lass descended,
And, as Sir Kuss intended,
With him she went and wended.

Who thought, when first they knew her,
She ever might aspire
To act Circassian Beauty
And walk upon the wire?
Yet such is her position—
Success attends ambition!
I've nothing more to tell you;
This pointless tale—ah, well, you
See 'twas made to sell you!

COSMOS.

WHAT to me are all your treasures?
Have I need of purchased pleasures,
Crescus, such as thine?
Come, I'll have thee make confession
Thou hast naught in thy possession,
And the world is mine.

I have all that thou hadst never;
Though I'm old, I'm young forever,
And happy I, at ease;
All I wish, I can create it;
Wing my soul, and elevate it
Where and when I please.

Of my secret make but trial:
Seest thou this little vial?
Dost thou not, then, think
Magic power to it pertaining,
All the world itself containing,
Though it holds but—*ink*?

AN EXCHANGE.

DEATH seizeth not the soul;
When life is past control—
No power left to hold it,
When we have lost or sold it—
Why care we for the loss of lives
Of suffering and sinning,
Well knowing that, for what survives,
A life is just beginning?

So, when our day arrives,
Why cling we to our lives?
Though they be clean and fair,
Or stained with sin and care,
The bargain cannot be adverse:
An old life for a new one;
Death cannot make a false soul worse,
Or ever change a true one!

To Irwin Russell.

Died in New Orleans, December 23d, 1879.

SMALL was thy share of all this world's delight,
And scant thy poet's crown of flowers of praise,
Yet ever catches quaint of quaint old days
Thou sang'st, and, singing, kept thy spirit bright;
Even as to lips the winds of winter bite
Some outcast wanderer sets his flute and plays,
Till blossom 'at his feet the icy ways,
And from the snowdrift's bitter wasting white
He hears the uprising carol of the lark,
Soaring from clover seas with summer ripe—
While freeze upon his cheek glad, foolish
tears.
Ah! let us hope that somewhere in thy dark,
Herrick's full note, and Suckling's pleasant
pipe
Are sounding still their solace in thine ears.
H. C. BUNNER, in "Puck."

Shakespeare in Italian.

AN Italian professor in a well-known American college was asked, on his return from a vacation, if he had enjoyed himself. "Yes," he answered, "I 'ave had a ver' quiet time. I've been reading *Shak-es-pe-are*, on the banks of the *Ches-a-pe-ak-e* Bay."

Poetical Amenities.

[We are permitted to print, for the first time, the following interesting exchange of civilities on the part of two favorite English and American poets, whose initials will be recognized by many. The epistle in eighteenth century style was written in Mr. Dobson's beautiful hand on the fly-leaf of a copy of "Hogarth," presented to Mr. Stedman.]

I.

TO E. C. S.

ON HIS DEPARTURE FROM LONDON.

"*Sis licet felix, ubicunque mavis
Et memor nostri . . . vivas.*"

GOOD-BYE! Kind breezes waft you o'er
Serenely to the Gallic shore!
Pray Heaven your lyre take no mischance
In that too-tuneful land of France,—
Especially 'twere well to care
If there be "poisonous honey" there!
But truce to jest. Be sure, although
Your bark to Gaul or Gades go,
There are in this old Isle a few
Who wish all good to Song—and You.

10 Redcliffe st., S. W., August 1, 1879. A. D.

II.

TO A. D.

ON RECEIVING THE FOREGOING EPISTLE.

HORATIUS:

From your side the Channel,
Where Britons say their prayers in flannel,
To Paris—where the Gauls still sin in
The lightest silks and whitest linen—
Your chanson comes, to me a bringer
Of welcome things, blithe brother-singer!
Of friendship leal, and rhymes, which rather
Than gold who wouldn't choose to gather?
Now had I, like that rare old Greek,
(Whose phrase from memory I speak,
A swift *crasnia pelcia*
To come and go at my desire,
I'd give him all that he could carry
Of thanks, and bid him fly—nor tarry
Until he passed them through your lattice,
And heard your hearty shout, *jam satis!*
Perhaps, in this new age, 'twere properer
That from the *Avenue de l'Opéra*,
(Where lights electric, silver-shining,
Cocottes and *petits-garçons* dining,
Make up a picture meretricious,
But quite Arabian and delicious),
The P. O., *via* Calais-Dover,
Should bear this warm God-Bless-You over!

Paris, August 7, 1879. E. C. S.

III.

A

FAMILIAR EPISTLE

TO

* * *Esq. of* * * *with a Life of the late
Ingenious Mr. Wm. Hogarth.*



DEAR COSMOPOLITAN,—I know

I should address you a *Rondeau*,
Or else announce what I've to say
At least *en Ballade fratricide*;

But no: for once I leave *Gymnasticks*,
And take to simple *Hudibrasticks*;

Why should I choose another Way,
When this was good enough for GAY?

You love, my FRIEND, with Me, I think,
That Age of Luftre and of Link;
Of *Chelfea* China and long "f"es,
Of Bag-wigs and of flowered Dreffes;
That Age of Folly and of Cards,
Of Hackney Chairs and Hackney Bards;
—No H—LTS, no K—G—N P—LS were then
Dispensing Competence to Men;
The gentle Trade was left to Churls,
Your frowly TONSONS and your CURLLS;
Mere Wolves in Ambush to attack
The AUTHOR in a Sheep-skin Back;
Then SAVAGE and his Brother-Sinners
In *Porridge-Island* div'd for Dinners;
Or doz'd on *Covent-Garden* Bulks,
And liken'd Letters to the Hulks;—
You know that by-gone Time, I say,
That aimless, easy-morall'd Day,
When rosy MORN found MADAM still
Wrangling at *Ombre* or *Quadrille*,
When good Sir JOHN reel'd Home to Bed,
From *Pontack's* or the *Shakespeare's Head*;
When TRIP convey'd his Masters Cloaths,
And took his Titles and his Oaths;
While BETTY, in a cast *Brocade*,
Ogled MY LORD at *Maquerade*;
When GARRICK play'd the guilty *Richard*,
Or mouth'd *Macbeth* with M^{rs} PRITCHARD;
When FOOTE grimac'd his snarling Wit;
When CHURCHILL bullied in the pit;
When the CUZZONI sang—

But there!

The further Catalogue I spare,
Having no Purpose to eclipse
That tedious tale of HOMER'S Ships;—
This is the MAN that drew it all
From *Pannier Alley* to the *Mall*,
Then turn'd and drew it once again
From *Bird-Cage-Walk* to *Lewknor's Lane*;—
Its Rakes and Fools, its Rogues and Sots;
Its brawling Quacks, its starveling Scots;
Its Ups and Downs, its Rags and Garters,
Its HENLEYS, LOVATS, MALCOLMS, CHARTRES;
Its Splendor, Squallor, Shame, Disease;
Its *quicquid agunt Homines*;—
Nor yet omitted to pourtray
Furens quid possit Foemina;—
In short, held up to ev'ry Clafs
NATURE'S unflatt'ring Looking-Glafs;
And, from his Canvafs, spoke to All
The Message of a JUVENAL.

Take Him. His Merits most aver:
His weak Point is—his Chronicler!

Nov^R 1, 1879.

A. D.

SCRIBNER'S MONTHLY.

VOL. XIX.

APRIL, 1880.

No. 6.

FRA LUIGI'S MARRIAGE.



"THE MAN IS DEAD," HE SAID.

"A SAD strange tale it is, and long to tell:
Would 't weary you to hear it, sir? It fell
To me alone to witness how he wed,
Young Fra Luigi. Years he has been dead,
Yet it doth seem but little while ago.
I loved him. That is how I came to
know
What no one knew but me.

"'Twas on a day

When all roads out of Rome were bright
and gay
With daisies and anemones; the spring
Thrilled every little lark and thrush to sing;
So full the sunlit air of bloom and song,
An hour seemed but a magic moment
long.

You know the grand Basilica they call

VOL. XIX.—55.

Paolo Santo, past the city wall?
'Twas there.

"The tale is strange, almost I fear
Lest it seem false unto your foreign ear.
But you may trust it, sir. I loved him so
I knew what she who bore him did not
know.

The day—this spring day full of song and
bloom—

I hear those larks yet singing in the
broom—

Had been for months appointed as the day
When he—his friend Andrea, too—should
lay

His worldly garments at the altar down
And take the Benedictine cowl and gown.
Perhaps you've seen that service, sir?

[Copyright, 1880, by Scribner & Co. All rights reserved.]

“Nay? Then
You'd like to hear how they make monks
of men.

I've not forgotten it. I loved him so
Each thing that happened on that day, I
know
As it were yesterday.”

“A monk? You said
Your tale was how the Fra Luigi wed.”

“Aye, so it is.”

“Did take the church as bride?
That is no secret marvelous to hide
Behind thy phrase.”

“Nay, no such empty phrase
Above my tale its idle shelter lays.
The Fra Luigi's bride had face more fair
Than any blossom in that spring-time air.
I stood that day the nearest to her side.
And well the face of Fra Luigi's bride
I knew, for I had served her house when
she

First gladdened it by her sweet infancy.
Stern sat the Abbot in his snow-white
chair,

Between the violet marble pillars fair.
The columns of red porphyry shone and
gleamed

Beneath the yellow quivering rays that
streamed

From myriad tapers making light so fast
The gorgeous Baldacchino scarce did cast
A shadow on the altar underneath,
Or on the faces cold and still as death
Of all the Benedictine brothers placed
In solemn circles which the altar faced.
The priests' robes blazed with scarlet and
with gold;

The swinging censers flashed with gems
untold,

And music wildly sorrowful and slow
All down the shadowed aisles went echo-
ing low.

As men who walked with heaven full in
sight,

Their faces lit by supernatural light,
Luigi and Andrea came and knelt.

The silence like a darkness could be felt
In which their voices rang out young and
clear,

Taking the vows so terrible to hear,
Obedience and poverty till death,
And chastity in every act and breath;
Between the vows sweet-chanted prayers
were said

That they might keep these vows till they
were dead:

Ah me! I think the good God sorrowed
then

To see such burdens laid on mortal men.
Next came the kiss of peace. In every
eye

Sprang tears, as gliding slow and noise-
lessly

Like ghosts, the Benedictines one by one
Embraced and kissed each novice.

“All was done
Now, save that last, most dreadful sight
of all,
The dying to the world.

One gold-wrought pall
Of black, the acolytes laid on the ground.
The music sank to lower, sadder sound.
Another pall was lifted high to spread
Above the bodies.

“With a joyous tread
Luigi came to lay him down. One glance
He lifted—oh, what sped the fatal chance?
What cruel fate his ardent eyes did guide
Unto her face who had been born his
bride?

I saw the glance. I saw the quick blood
mount

Her cheek as well as his. No man may
count

How swift love's motion in a vein can be;
Light is a laggard, by its ecstasy.

’Twas but a glance:—I said this tale was
strange—

Might seem to you but idle—such a
change

Did pass upon their faces, his and hers,
As comes upon the sea, when sudden stirs
A mighty wind. More ghastly now, and
white

Than he were dead, Luigi's face.

“The rite
Went on. The pall upon their forms was
dropped.

Rigid they lay, as if their hearts had
stopped:

The candles flickered down: the light grew
dim:

The singers chanted low, a funeral hymn:
The mothers' sobs broke on the stifled
air;

For living sons lay worse than lifeless
there.

At last the pall was lifted. Now com-
mands

To rise in name of God were read.
With hands

Unsteady in his joy, the Abbot pressed

Their brows, and with his benediction
blessed
The new-born men.

“Triumphant now, and loud
The Mass went on. The new-made brothers bowed
And knelt in prayer beside the rest.

At last
The tedious Mass was done. With eyes
downcast,
Slow-moving, one by one, the monks arose.
The silent threshold of their cloister close
They silent crossed. Luigi did not rise.
Thinking him rapt in prayer, with reverent
eyes
And hands crossed on his breast, the
brother next
Stood waiting—waited long—at length,
perplexed,
He bent him down, and gently on his arm
Laid hand: awe-stricken, in a quick alarm,
Upon his knees he fell; Luigi's head
He lifted. It fell back.

“‘The man is dead!’
He cried. The monks in wild confusion
bore
The body swiftly through the cloister door.
Some women shrieked and fainted: and
the crowd
Went surging from the church with mur-
murs loud.
None saw but me one white and anguished
face,
Fair as a broken lily in its grace,
Luigi's bride. With slow unflinching feet
And a composure deathly calm and sweet,
She walked the long and columned aisles,
nor bore
More heavily than she had borne before
Upon her father's arm.

“Next day, all Rome
Was ringing with the tale how God called
home,
In the first moment of his sacred vows,
The young Luigi. Well the priesthood
knows
How best to turn to good account each
thing
Which sets the multitude a marveling.
And it was well, Luigi's mother thought,
Her son so soon had certain heaven bought.
But I—I knew it was the heaven he
lost,
The terror of the other heaven's cost,
That broke his heart: and I, too, said
'twas well.
The grave was better than the cloister
cell!
And when a few months later, 'neath a
mound
Which daisies whitened still, and while the
sound
Of larks still lingered in the summer air,
Was laid Luigi's bride, so young, so fair,
I said that, too, was well: that heaven
was kind,
And in some world she would Luigi find.
They called it Roman fever, and they
said
She took it on that day the young monk
dead
Was found in San Paolo; that the place
Had always deadly been; a sad disgrace
The Benedictines there to double death
Were doomed. And thus, its ignorant,
idle breath
The world a brief space spent and then
forgot.
But I—I loved Luigi. I could not
Forget: nor ever will: my tale is true.
I loved him so: that is the way I
knew.”

SUCCESS WITH SMALL FRUITS. VI.

RASPBERRIES, BLACKBERRIES, CURRANTS AND GOOSEBERRIES FOR HOME AND MARKET.
PICKING AND MARKETING.

RASPBERRIES—(Continued.)

We now come to a class that are destined, I think, to be the raspberries of the future, or at least a type of them. I refer to seedlings of the three original species that have been described. As a rule, these native seedling varieties are comparatively

hardy and adapted to the climate of America. This adaptation applies to the South in the proportion that they possess the qualities of the *Rubus Strigosus* or *Occidentalis*. To the degree that the foreign element of *R. Ideus* exists they will require winter protection, and will be unable to thrive in light soils and under hot suns.

Forgetfulness of this principle is often the cause of much misapprehension and indiscriminating censure. I have known certain New Jersey fruit-growers to condemn a variety unsparingly. Would it not be more

they will exhibit the characteristics of the foreign species; or, finally, from the foreign and our native species may be produced a hybrid that will combine traits of each line of its lineage. A conspicuous example of the second

statement is found in Brinkle's Orange, originated by Dr. Brinkle many years ago.

It is essentially an Antwerp in character, and yet it is more vigorous, and adapted to a wider range of country than the Antwerp. The berry is of a beautiful buff color, and its delicious flavor is the accepted standard of excellence. At the same time, it is well known that it will

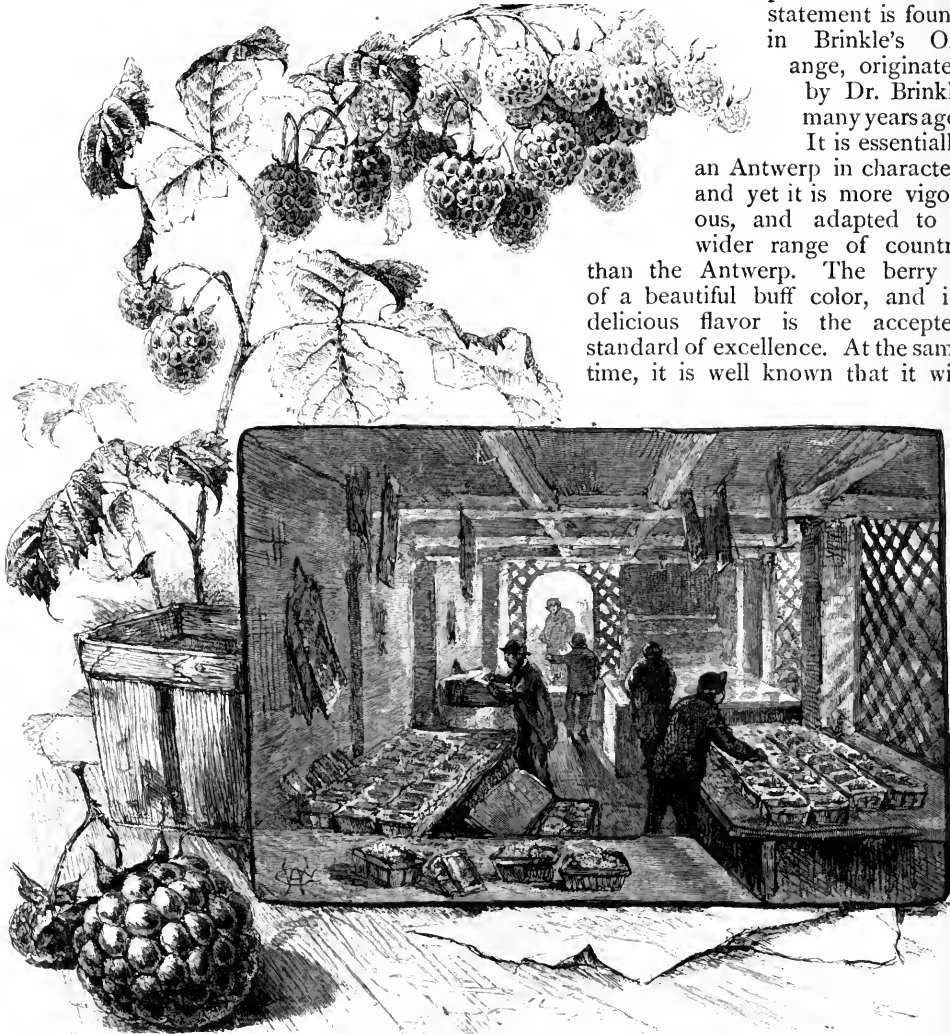

HERSTINE RASPBERRY.

A COOL PACKING-PLACE.

sensible to say it belongs to the *R. Ideus* class, and therefore is not adapted to our climate and light soil, and that in higher latitudes and on heavy land it may prove one of the best?

It should here be premised that these seedlings originated in this country. Perhaps they are the product solely of our native species, or they may result from crossing varieties of *R. Ideus*, in which case

not thrive under hot suns or upon light land. It can be raised south of New York only in cool, moist soils, and in half-shady locations; but at the north, where the conditions of growth are favorable, it produces strong branching canes, covered with white spines, and is exceedingly productive of large, light-colored berries that melt on the tongue. There is the same difference between it and the Brandywine that exists

between Stowell's Evergreen and flint field corn. It invariably requires winter protection.

The Pride of the Hudson possesses the same general character as the Orange, and approaches it very nearly in excellence. It certainly is the largest, most beautiful red raspberry now before the public, and in open competition at Boston, the very center of fine foreign berries, was awarded the first prize by the Massachusetts Horticultural Society. I find that it is undoubtedly a seedling of the Antwerp, and that it requires the same general treatment. Give it a moist soil and a half-shady location, such as may be found on the northern side of a fence or hedge, and it will become the pride of any Northern garden; but in the South, and on light soils, it can scarcely live. It should have winter protection. When the evening shadows are lengthening, as dainty a dish

may be gathered from such patrician fruits as ever graced the table of a royal epicure. For illustrations of these two varieties, see the March number of SCRIBNER.

In contrast with these native berries of foreign parentage we have the Herstine. After several years' experience on my own place, I regard it as the best early raspberry in existence. The berry is large, obtusely conical, bright red, and delicious in flavor. It is scarcely firm enough for market where it must be sent any great distance, but if picked promptly after it reddens, and packed in a cool, airy place, like that under my northern piazza, suggested in the engraving, it carries well and brings good prices. The canes are strong, red, stocky and covered with spines. They are but half-hardy, and I think it is best in our latitude to cover them before the first of December.



GATHERING A DAINTY DISH.

The canes of the Saunders, also sent out by Mr. Herstine, are much darker in color and not so vigorous, but sufficiently so. The berries are large, ripen later, are more globular, and are of the same excellent quality. This variety deserves greater popularity than it has received. It is also only half-hardy.

In the Clarke we undoubtedly have a variety containing a certain amount of the *R. Idaus* element. The berries are often very large, bright crimson, conical, with large hairy grains. Occasionally the fruit on my vines was very imperfect and crumbled badly in picking. I found that by cutting the canes rigorously back—even one-half—I obtained much larger and more perfect berries, and in increased quantities.

bly prevent it from becoming a favorite in market, since bright-hued berries are justly much preferred.

But Mr. Carpenter has sent out another seedling which I think is destined to have a brilliant future—the Caroline. It is thought to be a cross between the Catawissa and Brinkle's Orange. The canes are perfectly hardy, very strong, vigorous, branching, light-red, with a lighter bloom upon them here and there. It suckers freely and also propagates itself sparingly from the tips. The fruit is exceedingly abundant and is a round cap of a beautiful buff color almost equaling Brinkle's Orange in flavor. I think it will grow anywhere, and thus will find a place in innumerable gardens where the



GATHERING WILD BLACKBERRIES.

The canes are very strong, upright growers, ending usually in a thick tuft of foliage rather than long, drooping tips. It was originated by Mr. E. E. Clarke of New Haven, Conn., and is but half-hardy.

In the Ganargua and New Rochelle we have hybrids of the blackcap and red raspberries, the *R. Occidentalis* element predominating and manifesting itself in the stocky and branching character of the canes and in the fact that they propagate themselves by tips and not suckers. The New Rochelle, originated by Mr. E. W. Carpenter, of Rye, N. Y., is the best of this class. It is very vigorous, hardy and enormously productive, and the fruit is of good size. I do not like its sharp acid, however, and its dun or dusky brown color will proba-

Orange does not thrive. At the same time it is good enough for any garden.

The Reliance, a seedling of the Philadelphia but far superior to it, is doing remarkably well on my place, and I hear favorable accounts from other localities.

There are many other varieties that are either old and passing into obscurity or else so new and dubious in character that limited space forbids their mention. We will close with the Cuthbert, which that experienced and careful horticulturist, Dr. Hexamer, calls the "best raspberry now in existence."

This is a chance seedling which the late Thomas Cuthbert found in his garden at Riverdale, N. Y. His son has kindly furnished the following facts: "The raspberry

in question was discovered by my father about eleven years ago in the garden of our country seat at Riverdale-on-the-Hudson. It is probably a seedling of the Hudson River Antwerp, as it was found growing near the edge of a patch of that variety, but its great vigor of growth and the size and quality of the fruit marked it at once as a new and distinct kind. Its canes were carefully separated from the others and a small plantation was made of them. The next year, and from time to time since, plants were given to our friends in various parts of the State for trial. Without exception their reports have been favorable, particular mention having been made of their unusual vigor of growth, their hardiness and the firmness and good keeping qualities of the fruit. The first year or so we gave the canes winter protection, but finding that it was unnecessary we have discontinued it, and I have never heard of the canes being winter-killed."

The poet, W. C. Bryant, himself well versed in horticulture, in a letter to me once said :

"It has always seemed to me a scandal to our horticulture that in a region where the raspberry grows wild, we should not have a sort that would resist both the winter cold and summer heat, and produce abundantly."

After another year of observation and of much correspondence, extending even to California, I am convinced that the Cuthbert does "resist both the winter cold and summer heat, and produce abundantly," far better than any other raspberry that equals it in size and flavor. The artist has given us (page 809), an accurate portrait of the fruit, which, although so large, has the peculiar indentation of the grains and other characteristics of the *R. Strigosus*, showing that its constitution is derived mainly from our sturdy native species. The canes are strong, upright, branching if space permits, reddish-brown, spines abundant, but not very long and harsh. It is a rampant grower on good soil, but the foliage, so far from being rank and large, is delicate, and the under side of the leaves has a light silvery hue. After once getting hold of the soil it suckers immoderately, but is no worse in this respect than other vigorous varieties, and this tendency rapidly declines after the second year. Is it perfectly hardy? No; and I do not know of a single good raspberry that is, except, perhaps, the Turner, which, however, is inferior to the Cuthbert. I

have seen the latter badly winter-killed, but it had stood eight years on the same ground without injury before. Then, because of a rank growth late in the season, that especial patch was hit hard, while other fields but a few miles away were unharmed. If planted on well-drained soil, where the wood could ripen well, I think it would be injured very rarely, if ever. I have no faith in the talk about "perfectly hardy raspberries." Those who observe closely will often find our hardy native species killed to the ground, and I think many varieties suffer more from the mild, variable winters of the Middle States than from the steadily cold and snowy winters of the North. Moreover, any variety that has not the power of maintaining a healthful foliage through the hot season will usually be too feeble to resist the winter following, and the question of hardiness can often be settled better in August than in January. One of the most hopeful features of the Cuthbert, therefore, is its tough, sun-enduring foliage, which enables the wood to ripen perfectly. It has never received winter protection thus far, either in this region or in Michigan, where it is largely raised, but it may be found necessary to shield it somewhat in some localities. It is both absurd and dishonest to claim perfection for a fruit, and the Cuthbert, especially as it grows older and loses something of its pristine vigor, will, probably, like all other varieties, develop faults and weaknesses. We cannot too much deprecate the arrogant spirit often manifested in introducing new fruits. Interested persons insist on boundless praise, and, if their advice were followed, the fine old standards would be plowed out to make room for a new-comer that often proves, on trial, little better than a weed. The Cuthbert is not exactly a novelty. Through the gifts of the originator and sales continuing through several years, it has become widely scattered, and has proved a success in every instance, as far as I can learn. I show my faith in it by my works, for I am setting it out more largely than all other kinds together, even going so far as to rent land for the purpose. I am satisfied, from frequent inquiries in Washington Market, that it will take the lead of all others, and it is so firm that it can be shipped by rail, like a Wilson strawberry.

In Delaware and Southern New Jersey a variety named Queen of the Market is being largely set out. I have this variety in my specimen bed, side by side with

plants that came from Thomas Cuthbert's garden, and am almost satisfied that they are identical, and that Queen of the Market is but a synonym of the Cuthbert. Plants of this variety were sent to Delaware some

hard, disagreeable core when the berry is black but often only half-ripe. The bush is, in truth, what the ancients called it,—a bramble, and one of our Highland wild-cats could scarcely scratch more viciously than it

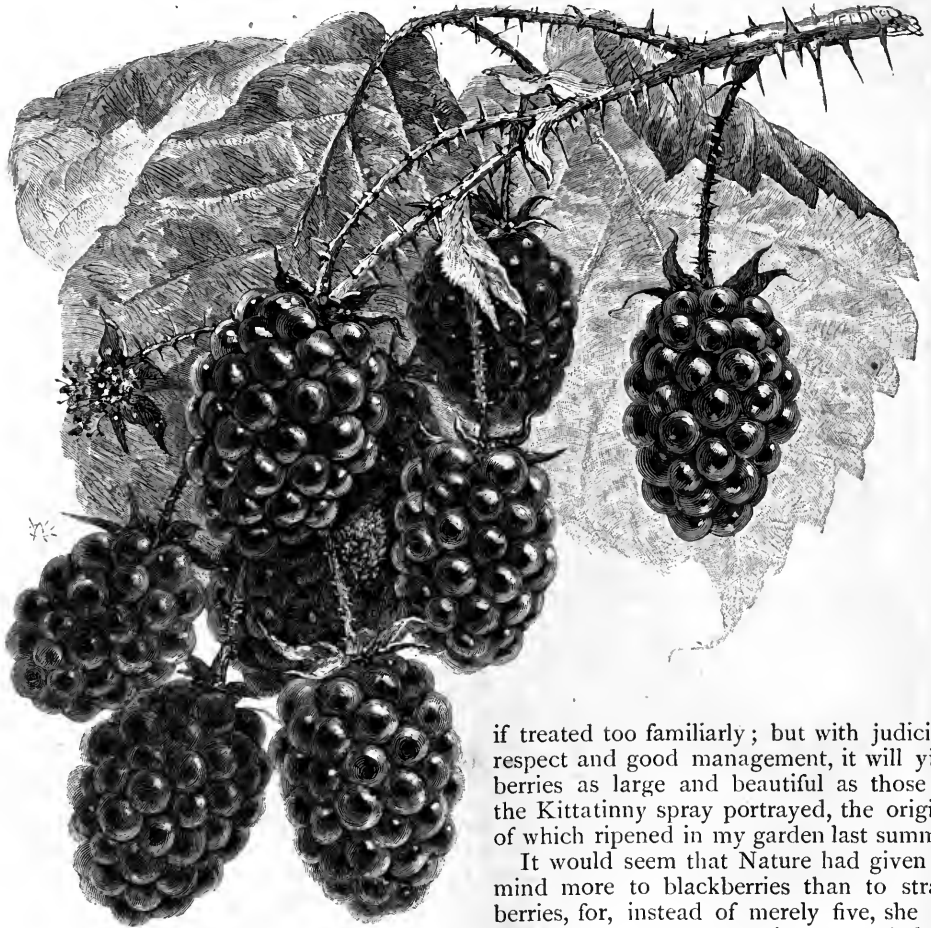

KITTATINNY BLACKBERRY.

years since, as they were to Michigan and California, and, wherever tested, they seem to win strong and immediate favor. Its chief fault in this locality is its lateness.

BLACKBERRIES.

THE small-fruit branch of the rose family is assuredly entitled to respect when it is remembered that the Blackberry is the blackest sheep in it. Unlike the raspberry, the drupes cling to the receptacle, which falls off with them when mature, and forms the

if treated too familiarly; but with judicious respect and good management, it will yield berries as large and beautiful as those on the Kittatinny spray portrayed, the original of which ripened in my garden last summer.

It would seem that Nature had given her mind more to blackberries than to strawberries, for, instead of merely five, she has scattered about 150 species up and down the globe. To describe all these would be a thorny experience indeed, robbing the reader of his patience as completely as he would be bereft of his clothing, should he literally attempt to go through them all. Therefore, I shall merely give Professor Gray's description of the two species which have furnished our few really good varieties:

"Rubus Villosus, High Blackberry. Everywhere along thickets, fence-rows, etc., and several varieties cultivated; stems one to six feet high, furrowed; prickles strong and hooked; leaflets three to five, ovate or lance-ovate, pointed, their lower surface and stalks hairy and glandular, the middle one long-stalked and sometimes heart-shaped; flowers racemed, rather large, with short bracts; fruit oblong or cylindrical.

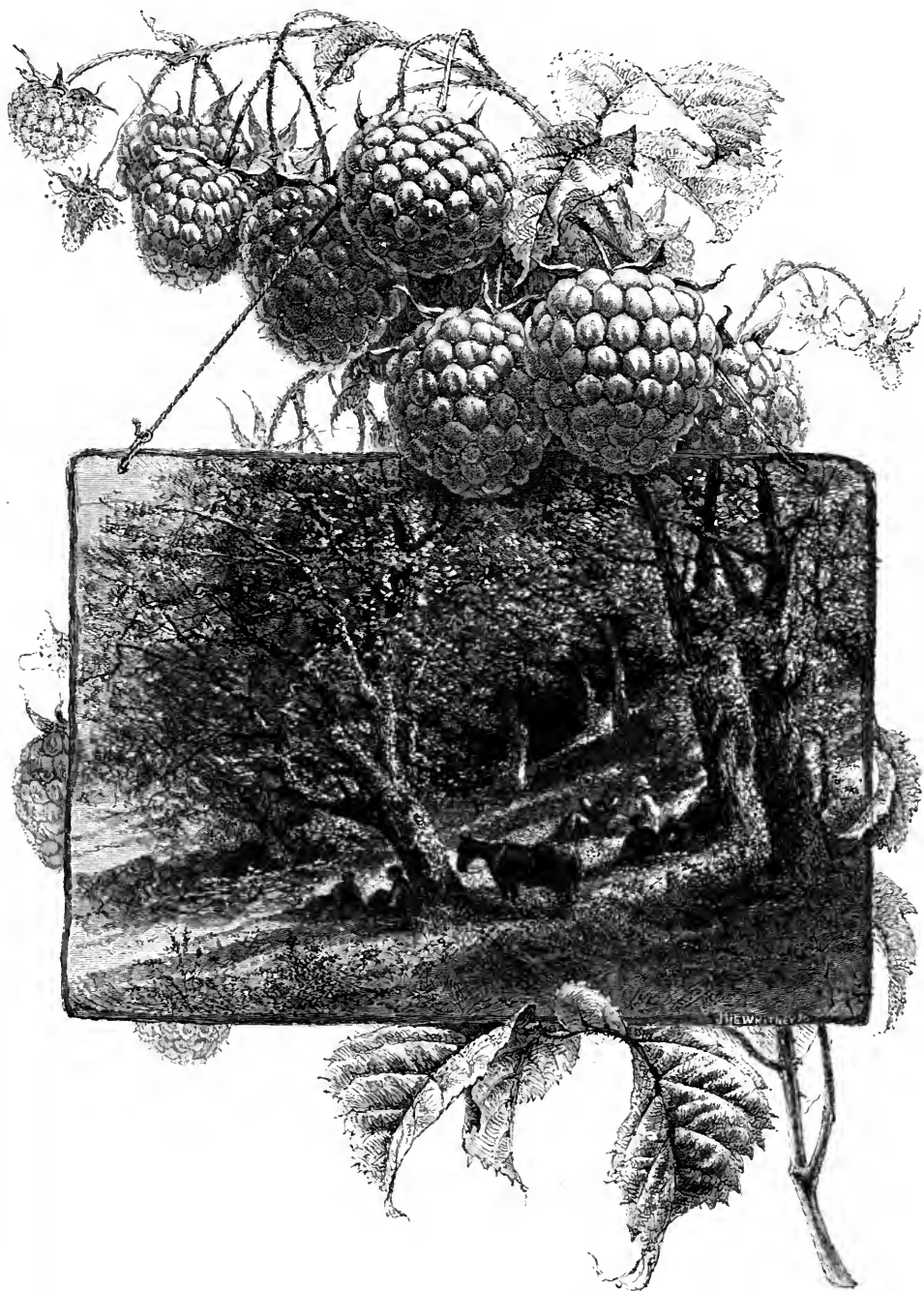

CUTHBERT RASPBERRY.

NOONING UNDER THE TREES.

"*R. Canadensis*, Low Blackberry or Dewberry. Rocky and sandy soil; long trailing, slightly prickly, smooth or smoothish, and with three to seven smaller leaflets than in the foregoing, the racemes of flowers with more leaf-like bracts, the fruit of fewer grains and ripening earlier."

In America there are innumerable varieties, since nature produces wild seedlings on every hill-side, and not a few seeds have been planted by horticulturists in the hope of originating a prize berry. Nature appears to have had the better fortune thus

far, for our best kinds are chance seedlings found growing wild.

It is not so many years since the blackberry was regarded as merely a bramble in this country, as it now is abroad, and people were content with such fruit as the woods and fields furnished. Even yet, in some localities, this supply is so abundant as to make the culture of the blackberry unprofitable. But a number of years since, Mr. Lewis A. Seacor led to better things by observing on the roadside, in the town of New Rochelle, Westchester County, New York, a bush flourishing where nature had planted it. This variety took kindly to civilization, and has done more to introduce this fruit to the garden than all kinds together. Mr. Donald G. Mitchell, in his breezy out-of-door book, "My Farm at Edgewood," gives its characteristics so admirably that I am tempted to quote him :

"The New Rochelle or Lawton Blackberry, has been despitefully spoken of by many; first, because the market fruit is generally bad, being plucked before it is fully ripened; and next, because in rich, clayey grounds, the briars, unless severely cut back, grow into a tangled, unapproachable forest, with all the juices exhausted in wood. But upon a soil moderately rich, a little gravelly and warm, protected from winds, served with occasional top-dressings and good hoeings, the Lawton bears magnificent burdens. Even then, if you wish to enjoy the richness of the fruit, you must not be hasty to pluck it. When the children say, with a shout, 'The blackberries are ripe!' I know they are black only, and I can wait. When the children report, 'The birds are eating the berries!' I know I can wait. But when they say, 'The bees are on the berries,' I know they are at their ripest. Then with baskets we sally out; I taking the middle rank, and the children the outer spray of boughs. Even now we gather those only which drop at the touch; these in a brimming saucer, with golden Alderney cream and a *soupoon* of powdered sugar, are Olympian nectar; they melt before the tongue can measure their full roundness, and seem to be mere bloated bubbles of forest honey."

Notwithstanding this eloquent plea and truthful statement, the Lawton is decidedly on the wane. It is so liable to be winter-killed even with the best of care, and its fruit is so unpalatable in its half-ripe condition, that it has given place to a more successful rival, the Kittatinny, discovered in the forest near the mountains in Warren County, N. J., whose Indian name has become a household word from association with this most delicious fruit. In finding it Mr. Wolverton has done more for the world than if he had opened a gold mine. Under good culture the fruit is very large, as shown in the engraving, sweet, rich and melting when fully ripe, but rather sour and hard when imma-

ture. It reaches its best condition if allowed to ripen fully on the vines, but the majority of pickers use their hands only, and no more think of making nice discriminations than of questioning nature according to the Baconian method: they gather all that are black or nearly so; still if this half-ripe fruit is allowed to stand in some cool, dry place for about twelve hours, Kittatinny berries may be had possessing nearly all their luscious qualities. The plant is an upright and very vigorous grower, exceedingly productive if soil and culture are suitable. Its leaves are long-pointed, "finely and unevenly serrate." The season of fruiting is medium, continuing from four to six weeks if moisture is maintained. Both of these varieties are derived from the *Rubus Villosus* species.

In contrast is the next best known sort, Wilson's Early, having many of the characteristics of the dewberry, or running blackberry, and therefore representing the second species described, *R. Canadensis*. Whether it is merely a sport from this species or a hybrid between it and the first-named or high blackberry cannot be accurately known, I imagine, for it also was found growing wild by Mr. John Wilson, of Burlington, N. J. Under high culture and with increasing age the plants become quite erect and stocky growers, but the ends of the cane are drooping. Frequently, however, they will trail along the ground and root at the tips like the common dewberry, and they rarely grow so stocky but that they can be bent over and covered with earth as the tender raspberries. It is well that this is possible, for it has so little power of resisting frost that, in the latitude of New York, a winter of ordinary severity kills the canes. I have always covered mine and thus secured, at slight expense, a sure and abundant crop. The fruit is earlier than the Kittatinny and tends to ripen altogether in about ten days. These advantages, with its large size and firmness, make it a valuable market berry in New Jersey, where hundreds of acres of it have been planted and where it is still very popular. Throughout the North and West it has been found too tender for cultivation unless protected. In flavor it is inferior to the Kittatinny or Snyder.

For many years the great desideratum has been a perfectly hardy blackberry, and this want has at last been met in part by the Snyder, a Western variety that seems able to endure without the slight-

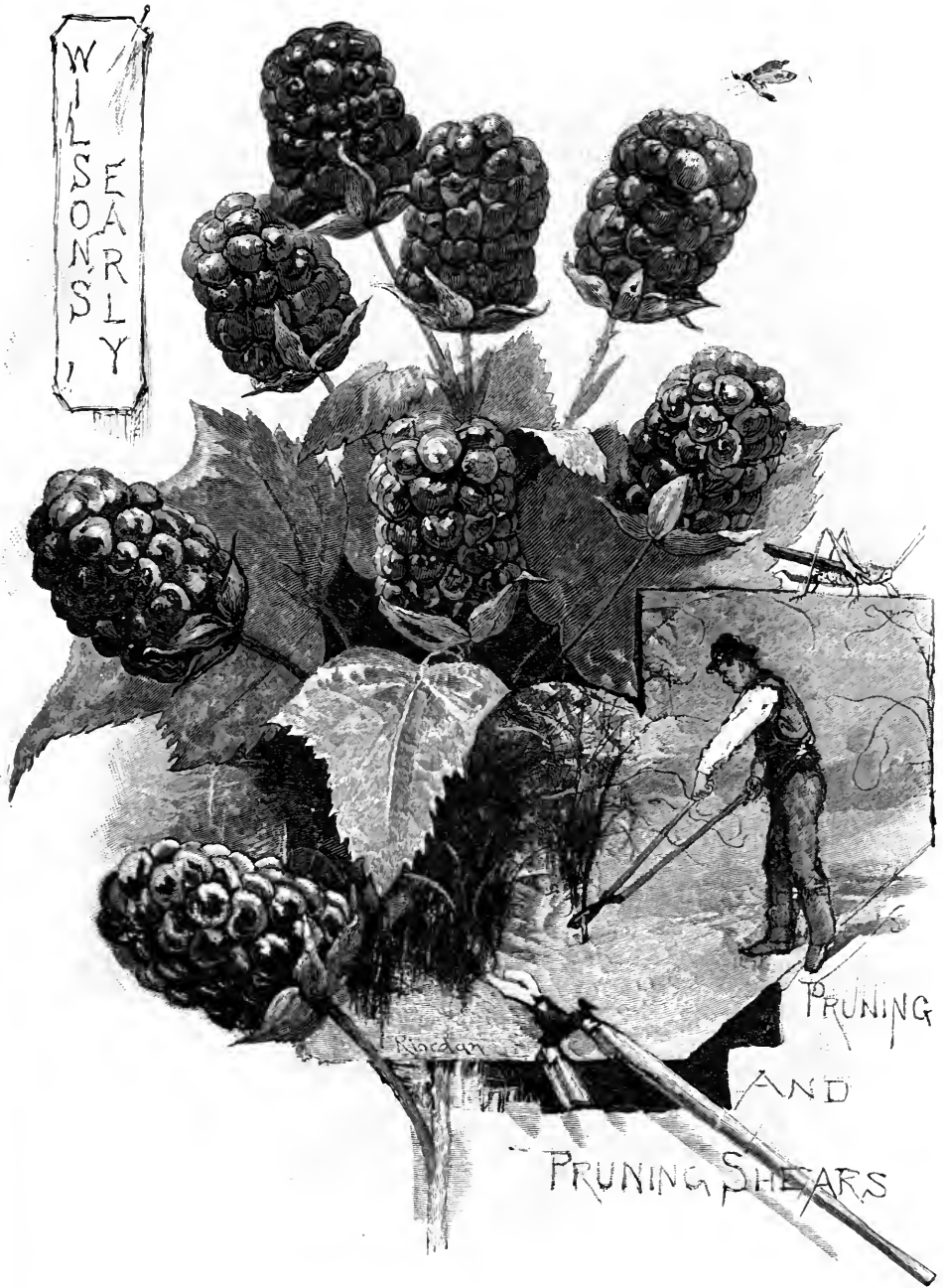

est injury the extremes of temperature common in the North-western States. I have followed its history from Nebraska eastward, and I have never heard of its being injured by frost. It originated on Mr.

Snyder's farm, near La Porte, Ind., about 1851, and is an upright, exceedingly vigorous and stocky grower, a true child of the *R. Villosus*. The engraving well suggests its wonderful productiveness, and the single



SNYDER BLACKBERRY.

berry given outlines the average size of the fruit under fair culture. Its one fault is thus seen at a glance—it is not quite large enough to compete with those already described. On moist land, with judicious pruning it could, however, be made to approach them very nearly, while its earliness, hardness, fine flavor and ability to grow and yield abundantly almost anywhere will lead to an increasing popularity. For home use size is not so important as flavor and certainty of crop. It is also more nearly ripe when first black than any other kind that I have seen; its thorns are straight, and therefore less vicious. I find that it is grow-

ing steadily in favor, and where the Kittatiny is winter-killed this hardy new variety leaves little cause for repining.

There are several kinds that are passing out of cultivation and not a few new candidates for favor, but their claims of superiority are as yet too doubtful to be recognized. Mr. James Wilson, of West Point, N. Y.,

found some magnificent wild berries growing on Crow Nest Mountain. The bush that bore them is now in my garden, and if it should produce fruit having a flavor equal to Rodman Drake's poem, Mr. Wilson has then found something more real than a "Culprit Fay."

PROPAGATION, CULTURE, ETC.

In most instances, I think more difficulty would be found in making a blackberry die than live. A plant set out in fall or early spring will thrive, if given the ghost of a chance; those set out late in spring, however,

often fail if subjected to heat and drouth while in the green, succulent condition of early growth. Like the raspberry, the blackberry should be set, if possible, while in a dormant condition. If planted late, shade should be given and moisture maintained until the danger of wilting and shriveling is past. I advise decidedly against late spring plantings on a large scale, but in early spring planting I have rarely lost a plant. Almost all that has been said concerning the planting and propagation of raspberries applies to this fruit. Set the plants two or three inches deeper than they were before. With the exception of the Early Wilson all speedily propagate themselves by suckers, and this variety can be in-

The treatment of the blackberry can best be indicated by merely noting wherein its requirements differ from the last-named and kindred fruit. For instance, it does best on light soils and in sunny exposures. The partial shade and moist, heavy land in which the raspberry luxuriates would produce a rank growth of canes that winter would generally find unripened and unable to endure the frost. Warm, well-drained, but not dry land, therefore, is the best. On hard, dry ground the fruit often never matures, but becomes mere collections of seeds; hence the need in the preparation of the soil of deep plowing and the thorough loosening, if possible, of the sub-soil with the lifting-plow. Any one who has traced blackberry roots in light



WHITE GRAPE CURRANTS.

creased readily by root cuttings. Indeed, better plants are usually obtained from all varieties by sowing slips of the root, as has already been explained in the paper on raspberries.

soils will seek to give them foraging-room. Neither does this fruit require the fertility needed in most instances by the raspberry. It inclines to grow too rankly at best, and demands mellowness rather than richness of soil.



IN THE CURRANT FIELD.

More room, also, should be given to the blackberry than to the raspberry. The rows should be six feet apart in the garden and eight feet in field culture, and the plants set three feet apart in the rows. At this distance 1,815 are required for an acre if one plant only is placed in a hill. Since these plants are usually cheap, if one is small or unprovided with good roots, it is well to plant two. If the ground is not very fertile, it is well to give the young plants a good start by scattering a liberal quantity of muck compost down the furrow in which they are planted. This insures the most vigorous growth of young canes in the rows rather than in the intervening spaces. As generally grown they require support, and may be staked as raspberries. Very often cheap post and wire trellises are employed and answer excellently. Under this system they can be grown in a continuous and bushy row, with care against overcrowding.

The ideal treatment of the blackberry is management rather than culture. More can be done with the thumb and finger at the right time than with the most savage pruning-shears after a year of neglect. In May and June the perennial roots send up vigorous shoots that grow with amazing rapidity until from five to ten feet high. Very often this summer growth is so brittle and heavy with foliage, that thunder-gusts break them off from the parent stem just beneath the ground, and the bearing cane of the coming year is lost. These and the following considerations show the need of summer pruning. Tall overgrown canes are much more liable to be injured by frost. They need high and expensive supports. Such branchless canes are by no means so productive as those which are made to throw out low and lateral shoots. They can always be made to do this by a timely pinch that takes off the terminal bud of the cane. This stops its upward

growth, and the buds beneath it, which otherwise might remain dormant, are immediately forced to become side branches near the ground where the snow may cover them, and over which, in the garden, straw or other light litter may be thrown on the approach of winter. It thus is seen that by early summer pinching the blackberry may be compelled to become as low and bushy a shrub as we desire and is made stocky and self-supporting at the same time. Usually it is not well to let the bushes grow over four feet high, and in regions where they are badly winter-killed I would keep them under three feet, so that the snow might be a protection. It should be remembered that the Kittatinny is so nearly hardy that in almost all instances a very slight covering saves it. The suckers that come up thickly between the rows can be cut away while small with the least possible trouble, but leave the patch or field to its own wild impulses for a year or so, and you will find a "slip of wilderness" in the midst of your garden that will require not a little strength and patience to subdue. By far the best weapon for such a battle and the best implement also for cutting out the old wood is the powerful and long-handled shears suggested in the engraving of the Early Wilson variety.

CURRANTS.

THEY were "curns" in our early boyhood, and "curns" they are still in the rural vernacular of many regions. In old English they were "corrans," because the people associated them with the raisins of the small Zante grape, once imported so exclusively from Corinth as to acquire the name of that city.

Under the tribe *Grossulariæ* of the Saxifrage family we find the *Ribes*, containing many species of currants and gooseberries; but in accordance with the scope of these papers we shall quote from Professor Gray (whose arrangement we follow) only those that furnish the currants of cultivation.

"*Ribes Rubrum*, red currant, cultivated, from Europe, also wild on our northern border, with straggling or reclining stems, somewhat heart-shaped, moderately three to five-lobed leaves, the lobes roundish and drooping racemes from lateral buds distinct from the leaf buds; edible berries red, or a white variety."

This is the parent of our cultivated red and white varieties. Currants are comparatively new-comers in the garden. When the Greek and Roman writers were carefully noting and naming the fruits of their time, the *ribes* tribe was as wild as any of



WEIGHING CURRANTS.

the hordes of the far north, in whose dim, cold, damp woods and bogs it then flourished; but like other northern tribes, it is making great improvement under the genial influences of civilization and culture.

Until within a century or two gardeners who cultivated currants at all were content with wild specimens from the woods. The exceedingly small acid fruit of these wildings was not calculated to inspire enthu-



LATE EMERALD GOOSEBERRY.

siasm, but a people possessing the surer qualities of patience and perseverance determined to develop them, and as a result we have the old Red and White Dutch varieties, as yet unsurpassed for the table. In the Victoria, Cherry and White Grape we have decided advances in size, but not in flavor.

CHOICE AND PREPARATION OF SOIL.

THE secret of success in the culture of currants is suggested by the fact that nature

has planted nearly every species of the *Ribes* in cold, damp, northern exposures. Throughout the woods and bogs of the Northern Hemisphere is found the scraggy, untamed, hardy stock from which has been developed the superb White Grape whose translucent beauty is scarcely reproduced even by the foregoing fine engraving. As with peoples so with plants; development does not eradicate constitutional traits and tendencies: so beneath all is the craving for the primeval conditions of life; and so the best success with the currant and gooseberry will assuredly be obtained by those who can give them a reasonable approach to the soil, climate and culture suggested by their damp, cold native haunts. As with the strawberry, then, the first requisite is, not wetness, but abundant and continuous moisture. Soil naturally deficient in this, and which cannot be made drouth-resisting by deep plowing and cultivation, is not adapted to the currant. Because the currant is found wild in bogs it does not follow that it can be grown successfully in undrained swamps. It will do better in such places than on dry, gravelly knolls, or on thin, light soils, but our fine civilized varieties need civilized conditions. The well-drained swamp may become the very best of currant fields; and damp, heavy land that is capable of deep, thorough cultivation should be selected if possible. When such is not to be had, then by deep plowing, sub-soiling, by abundant mulch around the plants throughout the summer, and by occasional waterings in the garden, counteracting the effects of lightness and dryness of soil, skill can go far in making good nature's deficiencies.

Next to depth of soil and moisture the currant requires fertility. It is justly called one of the "gross feeders," and is not particular as to the quality of its food so that it is abundant. I would still suggest, however, that it be fed according to its nature with heavy composts in which muck, leaf-mold, and the cleanings of the cow-stable are largely present. Wood-ashes and bone-meal are also most excellent. If stable or other light manures must be used, I would suggest that they be scattered liberally on the surface in the fall or early spring, and gradually worked in by cultivation. Thus used, their light heating qualities will do no harm, and they will keep the surface mellow and, therefore, moist.

The shadowy northern haunts of the wild currant also suggest that it will falter and



fail under the southern sun, and this is true. As we pass down through the Middle States we find it difficult to make even the hardy White and Red Dutch varieties thrive, and a point is at last reached where the bushes lose their leaves in the hot season and die. From the latitude of New York south, therefore, increasing effort should be made to supply the currants' constitutional need by giving partial shade among widely set apple trees, or, better still, by plant-

ing on the northern side of fences, buildings, etc. By giving cool, half-shady exposures in

moist land, the culture of the currant can be extended far to the South, especially in the high mountain regions. Even well to the North it is unprofitable when grown on light, thin, poor land, unless it receives liberal and skillful culture.

PLANTING, CULTIVATION AND PRUNING.

I REGARD autumn as the best season for planting currants, but have succeeded nearly as well in early spring. If kept moist, there is little danger of the plants dying at any time, but those set in the fall or early spring make, the first year, a much larger growth than those planted when the buds are swelling into leaves. Since they start so early, they should be set in spring as soon as the ground is dry enough to work, and in the autumn, any time after the leaves fall or the wood is ripe. The plants of commerce are one, two, and three years old, though not very many of the last are sold. I would as soon have one-year plants, if well rooted, as any, since they are cheaper and more certain to make strong, vigorous bushes if given generous treatment in the open field, than if left crowded too long in nursery rows. For the garden where fruit is desired as soon as possible, two and three year old plants may be preferable. After planting, cut the young bushes back one-half or two-thirds, so as to insure new and vigorous growth.

In field culture, I recommend that the rows be five feet apart, and the plants four feet from each other in the row. In this case 2,178 plants are required for an acre. If it is designed to cultivate them both ways, let the plants be set at right angles five feet apart, an acre now requiring 1,742 plants. Sink them two or three inches deeper than they stood in the nursery rows; even though in preparation, the ground has been well enriched, a shovel of compost around the young plant gives it a fine send-off, and hastens the development of a profitable bush.

In the field and for market, I would urge that currants be grown invariably in bush rather than in tree form. English writers, and some here who follow them, recommend the latter method; but it is not adapted to our climate and to such limited attention as we can afford to give. The borers, moreover, having but a single stem to work upon, would soon cause many vacancies in the rows.

Currants are grown for market with large and increasing profits—indeed, there is scarcely

a fruit that now pays better. The graphic pencil of Miss Curtis has well suggested the July scenes on Mr. Connel's place, near Newburgh,—one of the largest currant farms in the country.

In the garden and for home use there is the widest latitude. We may content ourselves, as many do, with a few old Red Dutch bushes that, for a generation, have struggled with grass and burdocks. We may do a little better, and set out plants in ordinary garden soil, but forget for years to give a particle of food to the starving bushes, remarking annually, with increasing emphasis, that they must be "running out." Few plants of the garden need high feeding more, and no others are more generally starved. I will guarantee that there are successful farmers who no more think of manuring a currant-bush than of feeding crows. This fruit will live, no matter how we abuse it, but there is scarcely any that responds more quickly to generous treatment, and in the garden, where it is not necessary to keep such a single eye to the margin of profit, many beautiful, interesting things can be done with the currant. The majority will be satisfied with large, vigorous bushes, well enriched, mulched, and skillfully pruned. If we choose, however, we may train them into pretty little trees, in the form of an umbrella, a globe, or a pyramid, according to our fancy, and, by watchfulness and the use of ashes, we may keep away the borers. The beautiful cluster of Cherry currants seen in the engraving was taken from a little tree about three feet high, grown in the following simple manner. I found a few vigorous shoots that had made a growth of nearly three feet in a single season. With the exception of the terminal bud and three or four just below it, I disbudded these shoots carefully, embedded the lower ends six inches in moist soil as one would an ordinary cutting, and they speedily took root and developed into little trees. Much taller and more ornamental currant and gooseberry trees can be obtained by grafting any variety we wish on the Missouri species (*Ribes Aureum*). These, as the artist has suggested, can be made pretty and useful ornaments of the lawn, as well as of the garden. Instead, therefore, of weed-choked, sprawling, unsightly objects, currant-bushes can be made things of beauty, as well as of sterling worth.

The cultivation of the currant is very simple. As early in the spring as the ground is dry enough it should be thoroughly

stirred by plow or cultivator, and all perennial weeds and grasses just around the bushes taken out with pronged hoes or forks. If a liberal top-dressing of compost or some other fertilizer was not given in the autumn, which is the best time to apply it, let it be spread over the roots (not up



CURRENTS AND GOOSEBERRIES IN TREE FORM.

against the stems) before the first spring cultivation. While the bushes are still young they can be cultivated and kept clean, like any hoed crop, but after they come into bearing—say the third summer—a different course must be adopted. If the ground is kept mellow and bare under the bushes, the fruit will be so splashed with earth as to be unsalable, and washed fruit

is scarcely fit for the table. We very properly wish it with just the bloom and coloring which nature is a month or more in elaborating. Muddy or rinsed fruit suggests the sty, not a dining-room. A mulch of leaves, straw, evergreen boughs—anything that will keep the ground clean—applied immediately after the early spring culture, is the best and most obvious way of preserving the fruit, and this method also secures all the good results which have been shown to follow mulching. Where it is not convenient to mulch, I would suggest that the ground be left undisturbed after the first thorough culture until the fruit is gathered. The weeds that grow in the interval may be mowed and allowed to fall under the bushes. By the end of June the soil will have become so fixed that, with a partial sod of weeds, the fruit may hang over, or even rest upon it, without being splashed by the heavy rains then prevalent. This course is not so neat as clean cultivation or mulching. Few fruit-growers, however, can afford to make appearances the first consideration. I have heard of oats being sown among the bushes to keep the fruit clean, but their growth must check the best development of the fruit quite as much as the natural crops of weeds. It would be better to give clean culture and grow rye, or any early maturing green crop, somewhere else, and when the fruit began to turn spread it under the bushes. On many places the mowings of weedy, swampy places would be found sufficient for the purpose. After the fruit is gathered, start the cultivator and hoe at once, so as to secure vigorous foliage and healthful growth throughout the entire summer.

Pruning may be done any time after the leaves fall, and success depends upon its judicious and rigorous performance. The English gardeners have recognized this fact and they have as minute and careful a system as we apply to the grape. But these formal and rather arbitrary methods can scarcely be followed practically in our hurried American life. It seems to me that I can do no better than to lay down some sound and general principles and leave their working out to the judgment of the grower. In most instances, I imagine, our best gardeners rarely trim two bushes exactly alike, but deal with each according to its vigor and natural tendencies, for a currant-bush has not a little individuality.

A young bush needs cutting back like a young grape-vine and for the same reason.

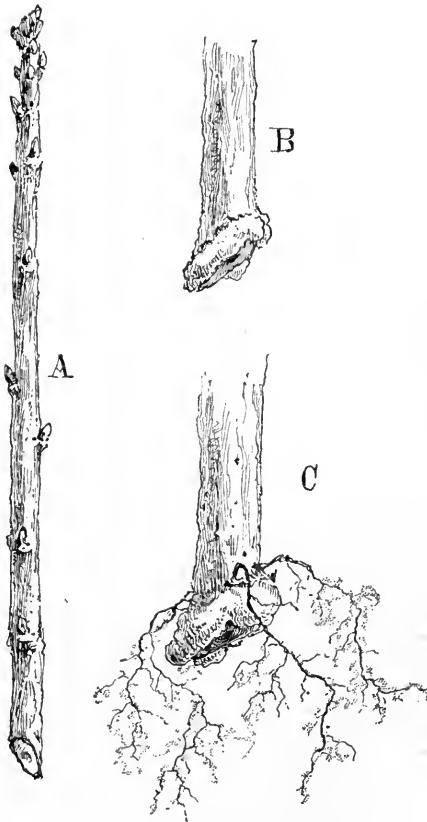

A, B, C, CURRANT-CUTTINGS AND CALLUS.

A grape-vine left to itself would soon become a mass of tangled wood yielding but little fruit, and that of inferior quality. In like manner, Nature, uncurbed, gives us a great, straggling bush that is choked and rendered barren by its own luxuriance. Air and light are essential, and the knife must make spaces for them. Cutting back and shortening branches develop fruit-buds. Otherwise we have long, unproductive reaches of wood. This is especially true of the Cherry and other varieties resembling it. The judicious use of the knife, kept up from year to year, will almost double their productiveness. Again, too much very young and too much old wood are causes of unfruitfulness. The skillful cultivator seeks to produce and preserve many points of branching and short spurs, for it is here that the little fruit-buds cluster thickly. When a branch is becoming black and feeble from age, cut it back to the root that space may be given for younger growth. From six to twelve bearing stems, from three to five feet high with their shortened branches and fruit-

spurs, may be allowed to grow from the roots, according to the vigor of the plant and the space allotted to it. Usually, too many suckers start in the spring. Unless the crop of young wood is valuable for propagation, all except such as are needed to renew the bush should be cut out as early as possible, before they have injured the forming crop. In England, much attention is paid to summer-pruning, and here much might be accomplished by it if we had, or would take, the time.

PROPAGATION.

PRUNING naturally leads to the subject of propagation, for much of that which is cut away, so far from being useless, is often of great value to the nurseryman, and there are few who grow this fruit for market who

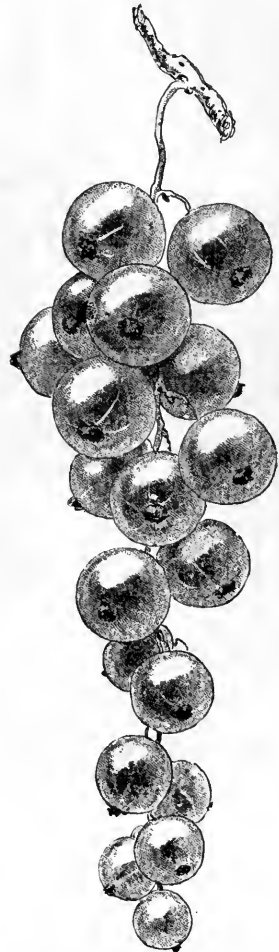

THE IDEAL VERSAILLES CLUSTER.

might not turn many an honest penny if they would take the refuse young wood of the previous summer's growth and develop it into salable bushes. In most instances a market would be found in their own neighborhood. Nothing is easier than success

soon become dry sticks. The very best course is to make and plant our cuttings in September or very early in October—just as soon as the leaves fall or will rub off readily. The wood cutting like the root-slip, must make a callus at its base be-



CHERRY CURRANTS.

in raising young currant-bushes except failure. If cuttings are treated in accordance with their demand for moisture and coolness they grow with almost certainty. If subjected to heat and drouth they usually

fore there can be growth. From this the roots start out. Therefore, the earlier in the fall that cuttings are made, the more time for the formation of this callus. Often autumn-planted cuttings are well rooted

before winter and have just that much start over those that must begin life in the spring. (See cut, page 820.) Six inches is the average length. Let them be sunk in deep, rich, moist, but thoroughly well-drained, soil so deeply as to leave but two or three buds above-ground. In the garden, where the design is to raise a few fine bushes for home use merely, let the rows be two feet apart and the cuttings six inches apart in the row. In raising them by the thousand for market we must economize space and labor and therefore one of the best methods, after rendering the ground mellow and smooth, is to stretch a line across the plat or field; then beginning on one side of the line to strike a spade its full depth into the soil, press it forward and draw it out. This leaves a slight opening of the width and depth of the spade, and a boy, following, inserts in this three cuttings, one in the middle and one at each end. The man then steps back and drives the spade down again about three inches in the rear of the first opening, and as he presses his spade forward to make a second, he closes up the first opening, pressing—indeed almost pinching—the earth around the three slips that have just been thrust down, until but two or three buds are above the surface. We thus have a row of cuttings, three abreast and about three inches apart, across the entire field. A space of three feet is left for cultivation and then we plant as before another triple row. These thick rows should be taken up the following fall when the largest may be sold or planted where they are to fruit, and the smaller ones replanted in nursery rows. When land is abundant the cuttings may be sunk in single rows with sufficient space between for horse cultivation, and allowed to mature into two-year-old plants without removal. If these are not planted or sold they should be cut back rigorously before making the third year's growth.

In moist land, cuttings can be made to grow if set out even late in the spring, especially if top-dressed and mulched; but if they are to be started on high, dry land, they should be out sufficiently early in the autumn to become rooted before winter. If our land is of a nature that tends to throw roots out of the ground—and moist, heavy land has this tendency—it may be best to bury cuttings in bundles tied up with fine wire, on a dry knoll below the action of frost, and set them out early—as early as possible—in the spring. At any

season, the rows of cuttings should be well top-dressed with fine manure, and, if planted in autumn, they should be so well covered with straw, leaves, or some litter, as not to suffer or be thrown out in freezing and thawing weather. I manage to get half my cuttings out in the fall, and half in early spring.

In the green-house, and even out-of-doors under very favorable circumstances, plants may be grown from single buds, and green wood also propagates readily under glass.

A vigorous young plant, with roots attached, may often be obtained by breaking off the suckers that start beneath the surface around the stems; new plants are also readily made by layering or bending bushes over and throwing earth upon them; but more shapely, and usually more vigorous, bushes are obtained by simple cuttings, as I have described.

When it is designed to grow a cutting in a tree form, all the buds but two or three at the top should be carefully removed.

INSECT ENEMIES.

WE have not only imported our best currants from Europe, but also their worst enemies. The most formidable of these is popularly known as the currant-worm. Robert Thompson, the English authority, thus describes it: "The magpie-moth (*abraxas grossulariata*) deposits its eggs upon the foliage, and from them is hatched a slightly hairy cream-colored caterpillar, spotted with black and marked with orange along the sides, and which forms a loop in walking. It feeds upon the leaves, devouring all but the petiole, and often entirely defoliating both gooseberry and currant bushes. It changes into a pupa in May or June, and in about three weeks afterward the perfect insect makes its appearance."

The chief remedy has been thus far dusting the foliage and worms with powdered white hellebore. A writer in the "Rural New-Yorker" recommends the following: "To one pailful of wood ashes add one quart each of white hellebore and flour of sulphur; mix thoroughly; apply by sifting on the bushes while the dew is on them. I used nothing else on my plantation of over two acres last season, and want nothing better." I have heard that, if applied in a liquid form, a heaping table-spoonful of hellebore to a gallon of water is a good proportion.

At the meeting of the New Jersey Hor-

ticultural Society, it was stated by good authorities, as the result of actual experience, that tobacco dust would kill the worms as readily as hellebore. I hope this is true, since the latter is expensive when applied on a large scale, and the tobacco dust can be bought at from two dollars to three dollars per barrel. I shall try it next year. For the past two years, the worm has attacked my bushes savagely; but, as I am very fond of currants, and relish white powdered sugar more than hellebore, I fought the pests successfully by hand-picking. I kept a boy, at moderate wages, whose business it was to kill insects and worms. He had a lively time of it occasionally, for Nature sometimes indulges in a vixenish mood, and takes sides with the pests.

Black currants form quite a distinct class in appearance and flavor, and are not as popular with us as in England. They are stronger plants and of coarser growth than the red and white species, and do not require as high culture. They can be grown to advantage in tree form, as they are quite exempt from insect enemies. The tent caterpillar is the only one that I have seen injuring them. They also require much less pruning, since the best fruit is borne on the young wood of the previous year's growth. If they are grown as bushes, they need more room,—six feet apart each way,—and the knife need be used only to secure good form and space for air and light.

Of red currants the old Red Dutch is the most prominent. It is the currant of memory. From it was made the wine which our mothers and grandmothers felt that they could offer with perfect propriety to the minister, and there are rural homes to-day in which the impression still lingers that it is a kind of temperance drink. From it is usually made the currant jelly without which no lady would think of keeping house in the country. Mrs. Foote's charming drawing suggests one of the gravest questions in the domestic economy,—whether the jelly will "jell." Often it does not and cannot be made to. The secret that lies behind this perplexing fact is this: The currants have been left until over-ripe before picking, or they have been picked wet just after rain. Gather them when dry, and as soon as possible after they have turned red, and I am informed by the highest domestic authority that there will be no difficulty.

In flavor the Red Dutch is unequalled by any other red currant. It is also a variety that can scarcely be killed by abuse and

neglect, and it responds so generously to high culture and rigorous pruning, that it is an open question whether it cannot be made, after all, the most profitable for market, since it is so much more productive than the larger varieties, and can be made to approach them so nearly in size. Indeed, not a few are annually sold for Cherry currants.

The White Dutch is similar to the Red in the growth and character of the bush. The clusters, however, are a little shorter and the fruit is a little larger, and of a fine yellowish-white color, with a veined, translucent skin.

The White Grape is an advance in size upon the last-named, and its marvelous productiveness and beauty are well portrayed in the engraving. It is not so vigorous as the White Dutch, and is more spreading in its mode of growth, requiring careful pruning to make a shapely bush. The fruit, also, is not spread so evenly over the wood, but is produced more in bunches.

Dana's Transparent and other white varieties do not vary materially from either the White Grape or Dutch.

The great market currant is the Cherry. In the "Canadian Horticulturist," for September, 1878, I find the following:

"The history of this handsome currant is not without interest. Monsieur Adrienne Seneclouse, a distinguished horticulturist of Bourgogental, Loire, France, received it from Italy among a lot of other currants. He noticed the extraordinary size of the fruit, and gave it, in consequence, the name it yet bears. In the year 1843 it was fruited in the nursery of the Museum of Natural History, and figured from these samples in the *Annales de Flore et de Pomone*, for February, 1848. Dr. William W. Valk, of Flushing, Long Island, N. Y., introduced it to the notice of American fruit-growers in 1846, having imported some of the plants in the spring of that year."

This variety is now very widely disseminated, and its culture is apparently becoming increasingly profitable every year. Two essentials are requisite to success with it—high manuring and skillful pruning. It has the tendency to produce long branches, on which there are few or no buds. Rigorous cutting back so as to cause branching joints and fruit-spurs should be practiced annually. The foliage is strong and coarse, and the fruit much more acid than that of the Dutch family, but size and beauty carry the market, and the Cherry can be made, by high culture, very large and beautiful, as the engraving suggests.

Concerning the Versailles, or *La Versailles*, the horticultural doctors disagree so

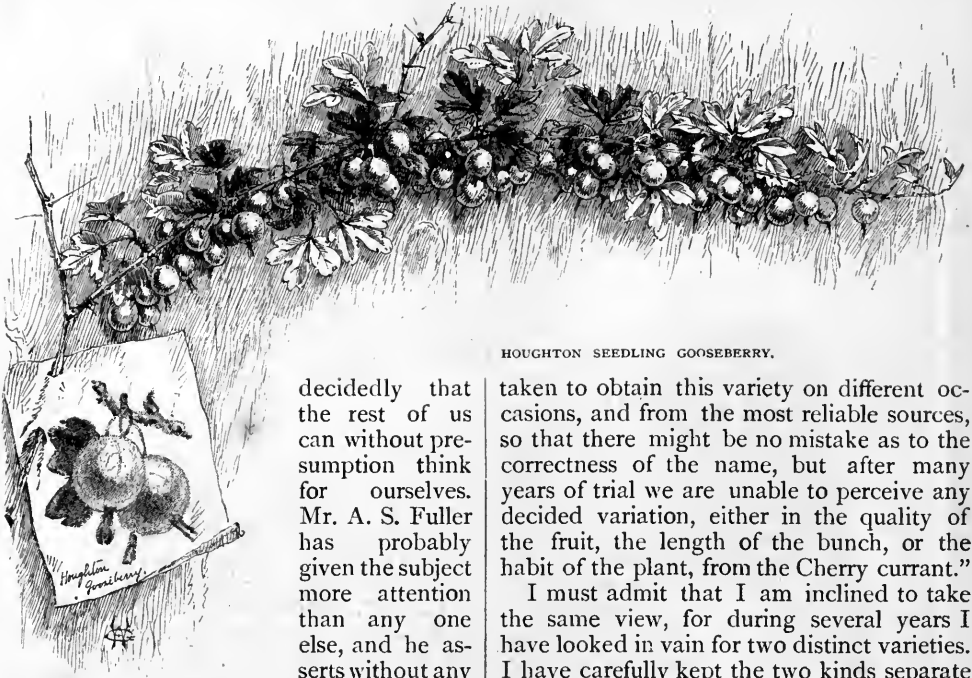

HOUGHTON SEEDLING GOOSEBERRY.

decidedly that the rest of us can without presumption think for ourselves. Mr. A. S. Fuller has probably given the subject more attention than any one else, and he asserts without any hesitation that

this so-called variety is identical with the Cherry. Mr. Fuller is certainly entitled to his opinion, for he imported Cherry and Versailles from all the leading nurserymen both here and abroad, not only once, but repeatedly, and could never obtain two distinct varieties. The writer in the "Canadian Horticulturist" also says in regard to the Versailles: "Some pains were

taken to obtain this variety on different occasions, and from the most reliable sources, so that there might be no mistake as to the correctness of the name, but after many years of trial we are unable to perceive any decided variation, either in the quality of the fruit, the length of the bunch, or the habit of the plant, from the Cherry currant."

I must admit that I am inclined to take the same view, for during several years I have looked in vain for two distinct varieties. I have carefully kept the two kinds separate but find in each case the same stout, stocky, short-jointed, erect shoots that are often devoid of buds and tend to become naked with age, and the same dark green, thick, bluntly and coarsely serrated foliage. Mr. Downing thinks the difference lies in the fact that while the Versailles strain produces many short bunches like the Cherry it also frequently bears clusters of which the cut on page 820 is a type, and that such long,



DOWNING GOOSEBERRY.



TAKING THE CRATES TO THE EVENING TRAIN.

WHITE DUTCH CURRANT.

tapering clusters are never formed on the Cherry. This is the only difference, if any exists, but in no instance have I been able to find this distinction well defined and sustained by the bearing plantations that I have seen. Mr. Downing, however, has had tenfold more experience than I have and his opinion is entitled to corresponding weight.

That this class is much inclined to "sport" I think all will admit. One bush in a row may be loaded with fruit year after year

and the next one be comparatively barren. The clusters on one bush may be short and characteristic of the Cherry while a neighboring bush in the same patch may show a tendency to mingle some long clusters with the short ones. I am satisfied that distinct and much-improved strains could be developed by propagating from bushes producing the best and most abundant fruit, and that a variety having characteristics of the ideal Versailles could be developed. The importance of this careful selection in prop-

agation can scarcely be overestimated, and the fruit-grower who should follow it up for a few years might almost double the productiveness and quality of many of his varieties.

Victoria (known also as May's Victoria and having a half dozen other synonyms) is a distinct variety whose great value consists in its lengthening out the currant season two or three weeks after the above-named kinds have matured. The fruit is also large—between the Red Dutch and Cherry in size—exceedingly abundant and, although rather acid, of good flavor when fully ripe. The clusters are very long,—from five to seven inches,—tapering, and the berries are bright red. If it is grown in some moist, cool, half-shady location the bunches will hang on the bushes very late in the season. In many localities it is found very profitable since it need not be sold until the others are out of the market. The young branches are rather slender, but the plant itself is very vigorous and can be grown at less expense than the Cherry.

There are many other named varieties, but in many instances the distinctions between them are slight; and as they are waning before the finer varieties that I have described, I shall not attempt to lighten the shadows that are gathering around them. The future promises more than the past, and I think that before many years elapse some fine new kinds will be introduced.

GOOSEBERRIES.

I HAVE treated the currant more fully than the gooseberry, not only because it is more popular in this country, but also because the greater part of my suggestions under that heading applies equally to this branch of the *Ribes* tribe. Possessing the same general characteristics, it should be treated on the same principles that were seen to be applicable to the currant. It flourishes best in the same cool exposures, and is the better for partial shade. Even in the south of England the more tender-skinned varieties often scald in the sun. However, I would recommend the shade of a fence or a northern hill-side, rather than overhanging branches of trees. A rich soil, especially one that is deep and moist, but not wet, is equally requisite, and the rigorous annual pruning is even more essential. As the wood becomes old and black, it should be cut out altogether. Fruit buds and spurs are produced on wood two or more years old, and cutting back

causes these, but they must not be allowed to become too crowded. To no fruit are air and light more essential.

We have in this country two very distinct classes of gooseberries—the first of foreign origin, and the second consisting of our native species. Gray thus describes *Ribes Grossularia*, the garden or English gooseberry: "Cultivated from Europe for the well-known fruit; thorny and prickly, with small obtuse, three to five lobed leaves, green flowers one to three on short pedicels, bell-shaped calyx, and large berry."

This native of northern Europe and the forests of the British Islands has been developed into the superb varieties which have been famous so long in England, but which we are able to grow with only partial success. It remembers its birthplace even more strongly than the currant, and the almost invariable mildew of our gardens is the sign of its homesickness. The cool, moist climate of England just suits it, and it is the pride of the gardeners of Lancashire to surpass the world in the development of large specimens. Mr. Downing writes: "We are indebted to the Lancashire weavers, who seem to have taken it up as a hobby, for nearly all the surprisingly large sorts of modern date. Their annual shows exhibit this fruit in its greatest perfection, and a gooseberry book is published in Manchester every year giving a list of all the prize sorts, etc." The extraordinary pains taken is suggested by the following quotation from the "Encyclopædia of Gardening": "To effect this increased size, every stimulant is applied that their ingenuity can suggest. They not only annually manure the soil richly, but also surround the plants with trenches of manure for the extremities of the roots to strike into, and form round the stem of each plant a basin, to be mulched, or manured, or watered, as may become necessary. When a root has extended too far from the stem it is uncovered, and all the strongest leaders are shortened back nearly one-half of their length, and covered with fresh marly loam, well manured. The effect of this pruning is to increase the number of fibers and spongioles, which form rapidly on the shortened roots, and strike out in all directions among the fresh, newly stirred loam, in search of nutriment." This is carrying culture to an extreme rarely, if ever, seen in America.

The Annual referred to above recorded one hundred and fifty-five gooseberry exhibitions in 1863. The number of varieties

is almost endless, and more than seven hundred prize sorts are named in Lindley's "Guide to the Orchard," and not one of them can be grown in this country, except under favorable conditions and with extra care. Even after supplying such conditions, they will often mildew in spite of our best efforts. Again, in some localities, and for obscure causes, they will thrive and continue for years quite free from this chief enemy of the foreign gooseberry. Repeated applications of flowers of sulphur over the bushes, from the time the fruit sets until it is ripe, is probably the best preventive. Thorough mulching, rigorous pruning, and high culture are also to be recommended. Those who garden for pleasure would do well to try some of these fine foreigners, and I would recommend Crown Bob, Roaring Lion and Whitesmith.

I am sorry to say that seedlings of these foreign varieties have the same tendency to mildew shown by their parents. The Late Emerald, suggested in the cut on page 816, and originated in an old garden at Newburgh, is a sad example of this fact. For many years it thrived in its birthplace without a trace of mildew, but on my own place it has behaved so badly that I do not recommend it. Were it not for this fault, I should grow no other variety.

In view of this inveterate evil, mildew, which is so seldom escaped and so difficult to overcome, we must turn to the second great class, our native species, since they are adapted to our climate. Of these there are several, but space permits the mention of but one, the *Ribes Hirtellum*, "commonest in our Eastern States, seldom downy, with very short thorns or none, very short peduncles, stamens and two-cleft style scarcely longer than the bell-shaped calyx; and the smooth berry is purple, small and sweet."—(Gray.) This is the parent of the most widely known of our native varieties, the Houghton Seedling, named from its originator, Abel Houghton, of Lynn, Massachusetts. The bush is a vigorous grower, that will thrive, with decent culture, on any moderately good soil, and is very rarely injured by mildew. At the same time, it improves greatly under high culture and pruning. The bush has a slender and even weeping habit of growth, and can be propagated readily by cuttings. From the Houghton have been grown two seedlings that now are justly the most popular.

The first and best of these is the Downing, originated by Mr. Charles Downing, of

Newburgh. The following is his description: "Upright, vigorous-growing plant, very productive; fruit somewhat larger than Houghton, roundish-oval, whitish-green, with the rib veins distinct; skin smooth; flesh rather soft, juicy." I consider this the best and most profitable variety that can be generally grown in this country. In flavor it is excellent. I have had good success with it whenever I have given it fair culture. It does not propagate readily from cuttings, out-of-doors, and therefore I increase it usually by layering.

The second seedling is Smith's Improved, a comparatively new variety that is winning favor. In its habit of growth, it more closely resembles the Houghton than the Downing, and yet is more vigorous and upright than its parent. The fruit is considerably larger than the Houghton, oval, light green, with a bloom, moderately firm, sweet and good.

The Mountain Seedling, which originated with the Shakers at Lebanon, New York, is the largest of the American varieties, but for some reason it does not gain in popularity.

Cluster, or American Red, is an old variety of unknown origin. The ancestral bush may have been found in the woods. The fruit is scarcely as large as that of the Houghton, is darker in color when fully ripe, hangs long on the bush, and is sweet and good. Barry says that it never mildews. Therefore it should be made one of the parents of new varieties, for in this direction lies the future of this fruit in America. When we remember that English gardeners started with a native species inferior to ours, we are led to believe that pains and skill like theirs will here result in kinds as superb and as perfectly adapted to our climate.

PICKING AND MARKETING FRUITS.

THE question often arises, "After all, do small fruits pay?" They pay some people well, and unless location, soil or climate is hopelessly against you, the degree of profit will depend upon your skill, judgment and industry. The raising of small fruits is like other callings in which some are getting rich, more earning a fair livelihood, and not a few failing. I do not seek to mislead any one by high-colored pictures. It is a business in which there is an abundance of sharp, keen competition, and ignorance, poor judgment, and shiftless, idle ways will be as fatal as in the work-shop, store or office.

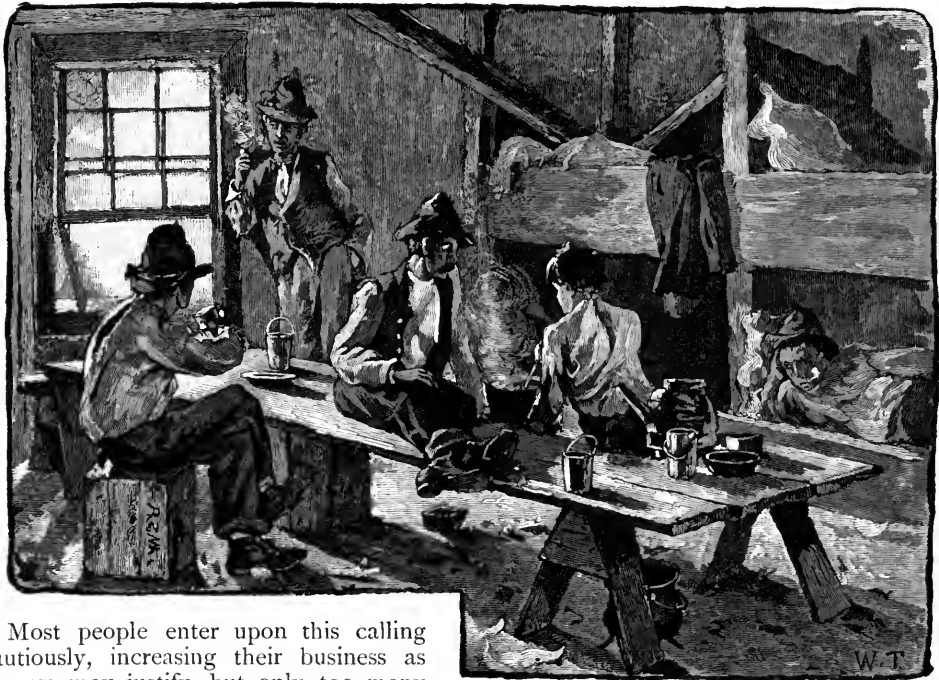

PICKERS' HEAD-QUARTERS.

Most people enter upon this calling cautiously, increasing their business as success may justify, but only too many invest largely at once in everything, soon tapering down to nothing. There ought to be considerable capital to start with, and an absence of the crushing burden of interest-money. No fruits yield any return before the second or third year; and there are often unfavorable seasons and glutted markets. Location is very important. The fruit farm must be situated where there is quick and cheap access to good markets. Such markets may be near, and good cultivation may produce an abundance of fruit, and still much loss may arise from not properly placing the fruit before purchasers and consumers. This leads to the question, Which are the best baskets, packages and methods of shipping?

After some years of experience and observation I am led to market my own fruit in square, quart baskets, and round pints for strawberries, and half-pints for raspberries, although pints answer equally well for a firm raspberry like the Cuthbert or Brandywine. If I were shipping from the South or from any distance I should choose baskets of which the round Beecher quarts and pints are the types. I think berries remain in good condition longer in this circular, open basket than in any other. Of the crate, it is sufficient to say that it should be light, strong and so constructed as to per-

mit free circulation of air. Few of the square "quart baskets" hold a quart. Indeed, there are but few honest baskets in the market, and the fact has come to be so well recognized that they are now sold by the "basket," the majority being aware that they are simply packages of fruit. Square quarts fill a crate compactly, requiring the least amount of space; there is no chance for the baskets to upset, and when the crate is opened there is a continuous surface of fruit which is very attractive. Very large, showy strawberries appear best, however, in round baskets. If my market were a near one, I should plan to dispose of the bulk of my crop in round pints, since they could be used for strawberries, the firmer raspberries and blackberries. Thus one stock and style of baskets would last throughout the whole season. Currants are sold by the pound, and it might be well to have two neat trays fitted to our crates, so as to prevent the need of extra packages and storage space. Nice-appearing boxes and baskets would answer equally well, however. Gooseberries are sold by measure, and are shipped in packages varying from quart baskets to barrels.

A little good taste bestowed upon the appearance of a fruit package often adds

several cents per pound or quart to the price received, and thus it comes that the brand of certain growers is sought after in the market.

The old "Marlboro' thirds" (see next page), still largely in use on the Hudson, should be superseded as soon as possible by baskets that permit circulation of air. The artist has suggested a style of packages of which we are in need,—boxes cheap enough to be given away with the fruit. The drawing is of a style called the "Sunnyside fruit-box," and can be obtained for about \$10 per 1,000. The purchaser sees a pretty box of fruit at a shop, buys and takes it with him and is at no trouble to return the box. The present frequent practice of pouring the fruit into brown paper bags is villainous.

Having procured the baskets which suit us best, the next thing is to fill them properly, and get them into market looking fresh and attractive. It is just at this point that very many wrong themselves or permit themselves to be wronged. The time is past when all strawberries will sell as such at so much per quart. Appearance often doubles the price, or makes it difficult to sell the fruit at all. Soiled, muddy berries, even though large, will fetch but wretched prices, therefore the importance of mulching. The fruit may be in beautiful condition upon the vines and yet be spoiled by careless picking. If possible the grower should carefully select his pickers and have them subscribe to a few plain rules like the following:

1. The berries must be picked with the thumb and fore-finger nails, and

not held in the hand but dropped into the basket at once.

2. No green, decayed or muddy berries will be received.

3. There must be no getting down upon all fours in the beds, thus crushing both green and ripe fruit.

4. There must be no "topping off" with large berries, but the fruit must be equally good all through the basket.

In order that the perishable berries may be gathered promptly and properly, fruit-growers are often obliged to erect small rude buildings upon their places, like the one suggested in the illustration, "Pickers' Head-quarters."

In the early pickings of Wilsons when many of the berries are of good size, and of all the large, choice kinds, it is best to make two grades, putting the large and small by themselves, and keeping varieties separate. A small frame with short legs at each cor-

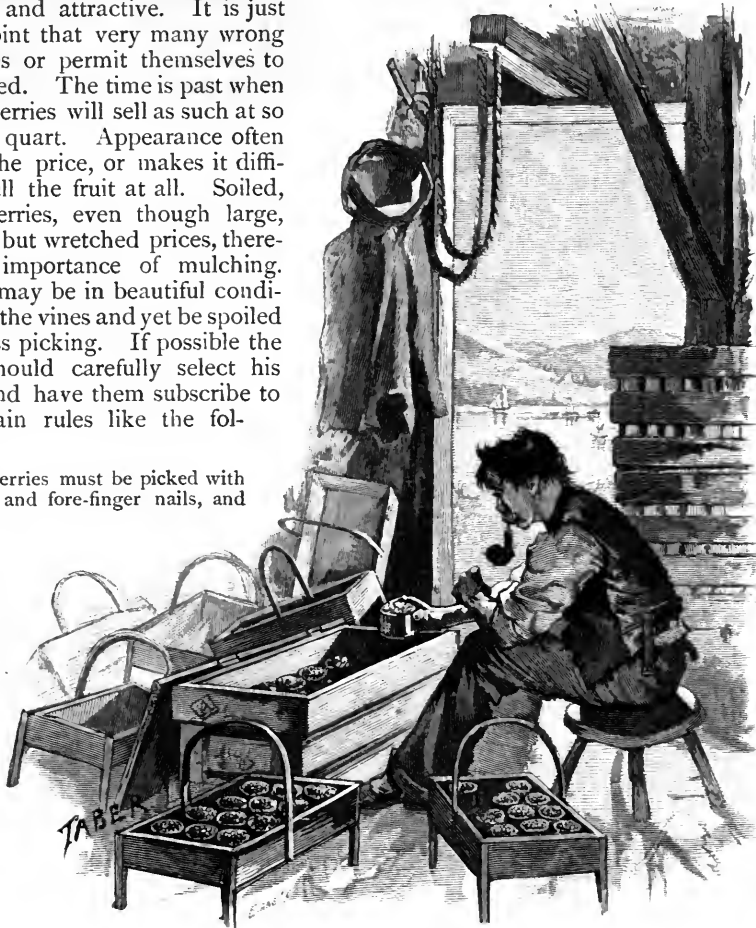

PACKING FOR MARKET.



PICKING RASPBERRIES ON THE HILL-SIDE.

ner and a handle is a convenient appliance to hold six or more baskets while picking. In the engravings, "Picking Raspberries on the Hill-side" and "Packing for Market," these frames are well indicated. Give to each picker two sets of baskets, one for the small and one for the large berries, and pay equally for both, so that there may be no motive to thwart your purpose; two cents per quart is the usual price. Have two styles of tickets, red and blue, for instance,—the red having a higher value and being given to those who bring the berries to the place of packing in good order, according to rule; let the baskets not picked in conformity to the rules be receipted for with the blue tickets. Receiving many of the latter soon becomes a kind of disgrace, and thus you appeal to the principle of self-

respect as well as self-interest. Get rid of those who persist in careless picking as soon as possible. Insist that the baskets be full and rounded up, and the fruit equal in quality down to the bottom. As far as possible let the hulls be down, out of sight, and only the fruit showing. If you have berries that are extra fine it will pay you to pick and pack them yourself, or have some one do it who can be depended upon. Do not pick the fruit, if you can help it, when it is wet with dew or rain; still there are times when this must be done to save it. Never let the baskets or crates stand long in the sun and wind, as berries so treated soon become dull and faded. As soon as a crate is filled put it under cover in a cool place till shipped to market. As far as possible insist upon careful, gentle handling.



MARLBORO' THIRDS.

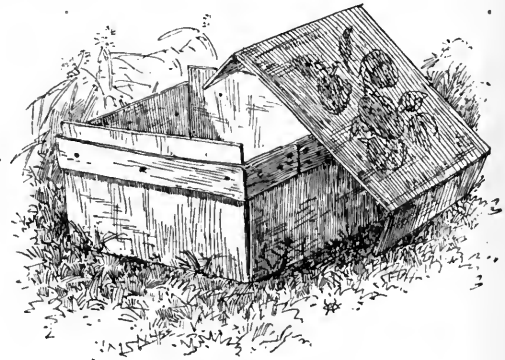

SUNNYSIDE FRUIT-BOX.

As these papers have appeared, I have been encouraged by words of approval from the best horticultural authorities. I shall not deny that I have been very glad to receive these favorable opinions, for I have had much and just doubt of my ability to satisfy those who have made these subjects a life-long study, and to whom, in fact, I am largely indebted for the little I do know. Still more am I pleased by assurances that I have turned the thoughts of many toward the garden—a place that is naturally, and, I think, correctly associated with man's primal and happiest condition. We must recognize, however, the sad change in both the gardening and gardeners of our degenerate world. In worm and insect, blight and mildew, in heat, frost, drouth and storm, in weeds so innumerable that we are tempted to believe that nature has a leaning toward total depravity, we have much to contend with; but in the ignorant, careless, and often dishonest, laborer who slashes away with his hap-hazard hoe, we find our chief obstacle to success. In spite of all

these drawbacks, the *work* of the garden is the *play* and *pleasure* that never palls, and which the oldest and wisest never out-grow.



A HAP-HAZARD HOE.

 MARY'S EASTER.

EASTER lilies freshly bloom
 O'er the open, conquered tomb;
 Cups of incense, pure and fair,
 Pour oblations on the air.
 Easter-glory sudden flows
 Through the portal none may close;
 Death and darkness flee away,
 Christ the Lord is risen to-day!

Shining forms are sitting by
 Where the folded garments lie;
 Loving Mary knows no fear
 While the waiting angels hear
 "They have taken my Lord away,
 Know ye where he lies to-day?"
 Sweet they answer to her cry,
 As their pinions pass her by.

See the Master stand to greet
 Her that weepeth at his feet.
 "Mary!" At the tender word
 Well she knows her risen Lord!
 All her love and passion breaks
 In the single word she speaks:—
 Hear the sweet "Rabboni!" tell
 All her woman-heart so well!

"Quickly go, and tell it out
 Unto others round about.
 Thou hast been forgiven much;
 Tell it, Mary, unto such.
 By thy love within thy heart,
 This my word to them impart;
 Death shall touch thy soul no more,
 Christ thy Lord hath gone before!"

LOUISIANA.*

BY FRANCES HODGSON BURNETT,

Author of "That Lass o' Lowrie's," "Surly Tim, and Other Stories," "Haworth's," etc.



"SHE WAITED IN VAIN."

CHAPTER XI.

A RUSTY NAIL.

ON Monday, Casey and his men came. Louisiana and her father were at breakfast when they struck their first blow at the end of the house which was to be renovated first.

The old man, hearing it, started violently—so violently that he almost upset the coffee at his elbow.

He laughed a tremulous sort of laugh.

"Why, I'm nervous!" he said. "Now, jest to think o' me a-bein' nervous!"

"I suppose," said Louisiana, "I am nervous as well. It made me start too. It had such a strange sound."

"Waal, now," he answered, "come to think on it, it hed—sorter. Seems like it wasn't sca'cely nat'ral. P'r'aps that's it."

Neither of them ate much breakfast, and when the meal was over they went out together to look at the workmen. They were very busy tearing off weather-boarding and wrenching out nails. Louisiana watched them with regretful eyes. In secret she was wishing that the low ceilings and painted walls might remain as they were. She had known them so long.

"I am afraid he is doing it to please me," she thought. "He does not believe me when I say I don't want it altered. He would never have had it done for himself."

Her father had seated himself on a pile of plank. He was rubbing his crossed leg as usual, but his hand trembled slightly.

"I druv them nails in myself," he said. "Ianthy wasn't but nineteen. She'd set yere an' watch me. It was two or three months arter we was married. She was mighty proud on it when it was all done. Little Tom he was born in thet thar room. The rest on 'em was born in the front room, 'n' they all died thar. Ianthy she died thar. I'd useder think I should——"

He stopped and glanced suddenly at Louisiana. He pulled himself up and smiled.

"Ye aint in the notion o' hevin' the cupoly," he said. "We kin hev it as soon as not—'n' seems ter me thar's a heap o' style to 'em."

"Anything that pleases you will please me, father," she said.

He gave her a mild, cheerful look.

"Ye don't take much int'russ in it yet, do ye?" he said. "But ye will when it gits along kinder. Lord! ye'll be as impatient as Ianthy an' me was, when it gits along."

She tried to think she would, but without very much success. She lingered about for a while, and at last went to her own room at the other end of the house and shut herself in.

Her trunk had been carried upstairs and set in its old place behind the door. She opened it and began to drag out the dresses and other adornments she had taken with her to the Springs. There was the blue muslin. She threw it on the floor and dropped beside it, half sitting, half kneeling. She laughed quite savagely.

"I thought it was very nice when I made it," she said. "I wonder how *she* would like to wear it?" She pulled out one thing after another until the floor around her was

strewn. Then she got up and left them, and ran to the bed and threw herself into a chair beside it, hiding her face in the pillow.

"Oh, how dull it is, and how lonely!" she said. "What shall I do? What shall I do?"

And while she sobbed she heard the blows upon the boards below.

Before she went down-stairs she replaced the things she had taken from the trunk. She packed them away neatly, and, having done it, turned the key upon them.

"Father," she said, at dinner, "there are some things upstairs I want to send to Cousin Jenny. I have done with them, and I think she'd like to have them."

"Dresses an' things, Louisianny?" he said.

"Yes," she answered. "I shall not need them any more. I—don't care for them."

"Don't——" he began, but stopped short, and, lifting his glass, swallowed the rest of the sentence in a large glass of milk.

"I'll tell Luther to send fer it," he said, afterward. "Jenny'll be real sot up, I reckon. Her pappy bein' so onfort'nit, she don't git much."

He ate scarcely more dinner than breakfast, and spent the afternoon in wandering here and there among the workmen. Sometimes he talked to them, and sometimes sat on his pile of plank and watched them in silence. Once, when no one was looking, he stooped down and picked up a rusty nail which had fallen from its place in a piece of board. After holding it in his hand for a little he furtively thrust it into his pocket, and seemed to experience a sense of relief after he had done it.

"Ye don't do nothin' toward helpin' us, Uncle Elbert," said one of the young men. (Every youngster within ten miles knew him as "Uncle Elbert.") "Ye aint as smart as ye was when last ye built, air ye?"

"No, boys," he answered, "I aint. That's so. I aint as smart, an'," he added, rather hurriedly, "it'd sorter go agin me to holf ye at what ye're doin' now. Not as I don't think it's time it was done, but—it'd sorter go agin me."

When Louisiana entered the house-room at dusk, she found him sitting by the fire, his body drooping forward, his head resting listlessly on his hand.

"I've got a touch o' dyspepsy, Louisianny," he said, "an' the knockin' hes kinder giv me a headache. I'll go to bed airy."

CHAPTER XII.

"MEBBE."

SHE had been so full of her own sharp pain and humiliation during the first few days that perhaps she had not been so quick to see as she would otherwise have been, but the time soon came when she awakened to a bewildered sense of new and strange trouble. She scarcely knew when it was that she first began to fancy that some change had taken place in her father. It was a change she could not comprehend when she recognized its presence. It was no alteration of his old, slow, quiet faithfulness to her. He had never been so faithfully tender. The first thing which awakened her thought of change was his redoubled tenderness. She found that he watched her constantly, in a patient, anxious way. When they were together she often discovered that he kept his eyes fixed upon her when he thought she was not aware of his gaze. He seemed reluctant to leave her alone, and continually managed to be near her, and yet it grew upon her at last that the old, homely good-fellowship between them had somehow been broken in upon, and existed no longer. It was not that he loved her any less—she was sure of that; but she had lost something, without knowing when or how she had lost it, or even exactly what it was. But his anxiety to please her grew day by day. He hurried the men who were at work upon the house.

"Louisiany, she'll enjoy it when it's done," he said to them. "Hurry up, boys, an' do yer plum best."

She had been at home about two weeks when he began to drive over to the nearest depot every day at "train time." It was about three miles distant, and he went over for several days in his spring wagon. At first he said nothing of his reason for making the journey, but one morning, as he stood at his horses' heads, he said to Louisiana, without turning to look at her, and affecting to be very busy with some portion of the harness:

"I've ben expectin' of some things fer a day or so, an' they haint come. I wasn't sure when I oughter look fer 'em—mebbe I've ben lookin' too soon—fer they haint come yet."

"Where were they to come from?" she asked.

"From—from New York City."

"From New York?" she echoed, trying to show an interest. "I did not know you sent there, father."

"I haint never done it afore," he answered. "These yere things—mebbe they'll come to-day, an then ye'll see 'em."

She asked no further questions, fancying that he had been buying some adornments for the new rooms which were to be a surprise for her. After he had gone away she thought a little sadly of his kindness to her and her unworthiness of it. At noon he came back and brought his prize with him.

He drove up slowly with it behind him in the wagon—a large, shining, new trunk—quite as big and ponderous as any she had seen at the Springs.

He got down and came up to her as she stood on the porch. He put his hand on her shoulder.

"I'll hev 'em took in an' ye kin look at 'em," he said. "It's some new things ye was a-needin'."

She began to guess dimly at what he meant, but she followed the trunk into the house without speaking. When they set it down she stood near while her father fumbled for the key and found it, turned it in the lock and threw back the lid.

"They're some things ye was a-needin'," he said. "I hope ye'll like 'em, honey."

She did not know what it was in his voice, or his face, or his simple manner that moved her so, but she did not look at what he had brought at all—she ran to him and caught his arm, dropped her face on it, and burst into tears.

"Father—father!" she cried. "Oh, father!"

"Look at 'em, Louisiany," he persisted, gently, "an' see if they suit ye. Thar aint no reason to cry, honey."

The words checked her and made her feel uncertain and bewildered again. She stopped crying and looked up at him, wondering if her emotion troubled him, but he did not meet her eye, and only seemed anxious that she should see what he had brought.

"I didn't tell ye all I hed in my mind when I went to the Springs," he said. "I hed a notion I'd like to see fer myself how things was. I knowed ye'd hev an idee thet ye couldn't ask me fer the kind o' things ye wanted, an' I knowed I knowed nothin' about what they was, so I ses to myself, 'I'll go an' stay a day an' watch and find out.' An' I went, an' I found out. Thar was a young woman thar as was dressed

purtier than any of 'em. An' she was clever an' friendly, an' I managed it so we got a-talkin'. She hed on a dress that took my fancy. It was mighty black an' thick—ye know it was cold after the rains—an' when we was talkin' I asked her if she mind a-tellin' me the name of it an' whar she'd bought it. An' she laughed some, an' said it was velvet, an' she'd got it to some store in New York City. An' I asked her if she'd write it down; I'd a little gal at home I wanted a dress off'n it fer—an' then, some-ways, we warmed up, an' I ses to her, 'She aint like me. If ye could see her ye'd never guess we was kin.' She hadn't never seen ye. She come the night ye left, but when I told her more about ye, she ses, 'I think I've heern on her. I heern she was very pretty.' An' I told her what I'd hed in my mind, an' it seemed like it took her fancy, an' she told me to get a paper an' pencil an' she'd tell me what to send fer an' whar to send. An' I sent fer 'em, an' thar they air."

She could not tell him that they were things not fit for her to wear. She looked at the rolls of silk and the laces and feminine extras with a bewildered feeling.

"They are beautiful things," she said. "I never thought of having such things for my own."

"Thar's no reason why ye shouldn't hev 'em," he said. "I'd oughter hev thought of 'em afore. Do they suit ye, Louisianny?"

"I should be very hard to please if they didn't," she answered. "They are only too beautiful for—a girl like me."

"They cayn't be that," he said, gravely. "I didn't see none no handsomer than you to the Springs, Louisianny, an' I ses to the lady as writ it all down fer me, I ses, 'What I want is fer her to hev what the best on 'em hev. I don't want nothin' no less than what she'd like to hev if she'd ben raised in New York or Philadelphly City. Thar aint no reason why she shouldn't hev it. Out of eleven she's all that's left, an' she desarves it all. She's young an' handsome, and she desarves it all.'"

"What did she say to that?" Louisiana asked.

He hesitated a moment before answering.

"She looked at me kinder queer fer a minnit," he replied at length. "An' then she ses, 'She'd oughter be a very happy gal,' ses she, 'with such a father,' an' I ses, 'I 'low she is—mebbe.'"

"Only maybe?" said the girl, "only maybe, father?"

She dropped the roll of silk she had been holding and went to him. She put her hand on his arm again and shook it a little, laughing in the same feverish fashion as when she had gone out to him on the porch on the day of her return. She had suddenly flushed up, and her eyes shone as he had seen them then.

"Only maybe," she said. "Why should I be unhappy? There's no reason. Look at me, with my fine house and my new things! There isn't any one happier in the world! There is nothing left for me to wish for. I have got too much!"

A new mood seemed to have taken possession of her all at once. She scarcely gave him a chance to speak. She drew him to the trunk's side, and made him stand near while she took the things out one by one. She exclaimed and laughed over them as she drew them forth. She held the dress materials up to her waist and neck to see how the colors became her; she tried on laces and sacques and furbelows and the hats which were said to have come from Paris.

"What will they say when they see me at meeting in them?" she said. "Brother Horner will forget his sermons. There never were such things in Bowersville before. I am almost afraid they will think I am putting on airs."

When she reached a box of long kid gloves at the bottom, she burst into such a shrill laugh that her father was startled. There was a tone of false exhilaration about her which was not what he had expected.

"See!" she cried, holding one of the longest pairs up, "eighteen buttons! And cream color! I can wear them with the cream-colored silk and cashmere at—at a festival!"

When she had looked at everything, the rag carpet was strewn with her riches,—with fashionable dress materials, with rich and delicate colors, with a hundred feminine and pretty whims.

"How could I help but be happy?" she said. "I am like a queen. I don't suppose queens have very much more, though we don't know much about queens, do we?"

She hung round her father's neck and kissed him in a fervent, excited way.

"You good old father!" she said, "you sweet old father!"

He took one of her soft, supple hands and held it between both his brown and horny ones.

"Louisianny," he said, "I 'low to make ye happy; ef the Lord haint nothin' agin it, I 'low to do it!"

He went out after that, and left her alone to set her things to rights; but when he had gone and closed the door, she did not touch them. She threw herself down flat upon the floor in the midst of them, her slender arms flung out, her eyes wide open and wild and dry.

CHAPTER XIII.

- A NEW PLAN.

AT last the day came when the house was finished and stood big and freshly painted and bare in the sun. Late one afternoon in the Indian summer, Casey and his men, having bestowed their last touches, collected their belongings and went away, leaving it a lasting monument to their ability. Inside, instead of the low ceilings, and painted wooden walls, there were high rooms and plaster and modern papering; outside, instead of the variegated piazza, was a substantial portico. The whole had been painted a warm gray, and Casey considered his job a neat one and was proud of it. When they were all gone Louisiana went out into the front yard to look at it. She stood in the grass and leaned against an apple-tree. It was near sunset, and both trees and grass were touched with a yellow glow so deep and mellow that it was almost a golden haze. Now that the long-continued hammering and sawing was at an end and all traces of its accompaniments removed, the stillness seemed intense. There was not a breath of wind stirring, or the piping of a bird to be heard. The girl clasped her slender arms about the tree's trunk and rested her cheek against the rough bark. She looked up piteously.

"I must try to get used to it," she said. "It is very much nicer—and I must try to get used to it."

But the strangeness of it was very hard on her at first. When she looked at it she had a startled feeling—as if when she had expected to see an old friend she had found herself suddenly face to face with a stranger.

Her father had gone to Bowersville early in the day, and she had been expecting his return for an hour or so. She left her place by the tree at length and went to the fence to watch for his coming down the road. But she waited in vain so long that she got

tired again and wandered back to the house and around to the back to where a new barn and stable had been built, painted and ornamented in accordance with the most novel designs. There was no other such barn or stable in the country, and their fame was already wide-spread and of an enviable nature.

As she approached these buildings Louisiana glanced up and uttered an exclamation. Her father was sitting upon the door-sill of the barn, and his horse was turned loose to graze upon the grass before him.

"Father," the girl cried, "I have been waiting for you. I thought you had not come."

"I've been yere a right smart while, Louisianny," he answered. "Ye wasn't 'round when I come, an' so ye didn't see me, I reckon."

He was pale, and spoke at first heavily and as if with an effort, but almost instantly he brightened.

"I've jest ben a-settin' yere a-steddyin'," he said. "A man wants to see it a few times an' take it sorter gradual afore he kin do it jestic. A-lookin' at it from yere, now," with a wide sweep of his hand toward the improvements, "ye kin see how much style thar is to it. Seems to me thet the— the mountains now, they look better. It— waal it kinder sets 'em off—it kinder sets 'em off."

"It is very much prettier," she answered. "Lord, yes! Thar aint no comparison. I was jest a-settin' thinkin' thet any one thet'd seed it as it was afore they'd not know it. Ianthy, fer instants—Ianthy *she* wouldn't sca'cely know it was home—thar's so much style to it."

He suddenly stopped and rested against the door-lintel. He was pale again, though he kept up a stout air of good cheer.

"Lord!" he said, after a little pause, "it's a heap stylisher!"

Presently he bent down and picked up a twig which lay on the ground at his feet. He began to strip the leaves from it with careful slowness, and he kept his eyes fixed on it as he went on talking.

"Ye'll never guess who I've ben a-talkin' to to-day, an' what I've ben talkin' to 'em about."

She put her hand on his knee caressingly. "Tell me, father," she said.

He laughed a jerky, high-pitched laugh. "I've ben talkin' to Jedge Powers," he said. "He's up yere from Howelsville, a-runnin' fer senator. He's sot his mind on

makin' it too, an' he was a-tellin' me what his principles was. He—he's got a heap o' principles. An' he told me his wife an' family was a-goin' to Europe. He was mighty sosh'erble—an' he said they was a-goin' to Europe."

He had stripped the last leaf from the twig and had begun upon the bark. Just at this juncture it slipped from his hand and fell on the ground. He bent down again to pick it up.

"Louisianny," he said, "how—would ye like to go to Europe?"

She started back amazed, but she could not catch even a glimpse of his face, he was so busy with the twig.

"I go to Europe—I!" she said. "I don't—I never thought of it. It is not people like us who go to Europe, father."

"Louisianny," he said, hurriedly, "what's agin it? Thar aint nothin'—nothin'! It come in my mind when Powers was a-tellin' me. I ses to myself, 'Why, here's the very thing fer Louisianny! Travel an' furrin langwidges an' new ways o' doin'. It's what she'd oughter hed long ago.' An' Powers he went on a-talkin' right while I was a-steddyin, an' he ses: 'Whar's that pretty darter o' yourn that we was so took with when we passed through Hamilton last summer? Why,' ses he,—he ses it hisself, Louisianny,—'why don't ye send her to Europe? Let her go with my wife. She'll take care of her.' An' I stopped him right thar. 'Do ye mean it, Jedge?' I ses. 'Yes,' ses he. 'Why not? My wife an' daughter hev talked about her many a time, an' said how they'd like to see her agin. Send her,' ses he. 'You're a rich man, an' ye kin afford it, Squire, if ye will.' An' I ses, 'So I kin ef she'd like to go, an' what's more, I'm a-goin' to ask her ef she would—fer thar aint nothin agin it—nothin'."

He paused for a moment and turned to look at her.

"That's what I was steddyin' about mostly, Louisianny," he said, "when I set yere afore ye come."

She had been sitting beside him, and she sprang to her feet and stood before him.

"Father," she cried, "are you tired of me?"

"Tired of ye, Louisianny?" he repeated.

"Tired of ye?"

She flung out her hand with a wild gesture and burst into tears.

"Are you tired of me?" she said again.

"Don't you love me any more? Don't

you want me as you used to? Could you do without me for months and months and know I was far away and couldn't come to you? No, you couldn't. You couldn't. I know that, though something—I don't know what—has come between us, and I feel it every minute, and most when you are kindest. Is there nothing in the way of my going away—nothing? Think again."

"Louisianny," he answered, "I cayn't think of nothin'—that's partic'lar."

She slipped down on her knee and threw herself on his breast, clinging to him with all her young strength.

"Are *you* nothing?" she cried. "Is all your love nothing? Are all your beautiful, good thoughts for my happiness 'nothing'? Is your loneliness nothing? Shall I leave you here to live by yourself in the new home which is strange to you—after you have given up the old one you knew and loved for me? Oh! what has made you think I have no heart, and no soul, and nothing to be grateful with? Have I ever been bad and cruel and hard to you that you can think it?"

She poured forth her love and grief and tender reproach on his breast with such innocent fervor that he could scarcely bear it. His eyes were wet too, and his furrowed, sunburnt cheeks, and his breath came short and fast while he held her close in his arms.

"Honey," he said, just as he had often spoken to her when she had been a little child, "Louisianny, honey, no! No, never! I never hed a thought agin ye, not in my bottermost heart. Did ye think it? Lord, no! Thar aint nothin' ye've never done in yer life that was meant to hurt or go agin me. Ye never did go agin me. Ye aint like me, honey; ye're kinder finer. Ye was borned so. I seed it when ye was in yer cradle. I've said it to Ianthy (an' sence ye're growed up I've said it more). Thar's things ye'd oughter hev thet's diff'rent from what most of us wants—it's through you a-bein' so much finer. Ye mustn't be so tender-hearted, honey, ye mustn't."

She clung more closely to him and cried afresh, though more softly.

"Nothing shall take me away from you," she said, "ever again. I went away once, and it would have been better if I had stayed at home. The people did not want me. They meant to be good to me, and they liked me, but—they hurt me without knowing it, and it would have been better if I had stayed here. *You* don't make me

feel ashamed, and sad, and bitter. *You* love me just as I am, and you would love me if I knew even less, and was more simple. Let me stay with you! Let us stay together always—always—always!”

He let her cry her fill, holding her pretty head tenderly and soothing her as best he could. Somehow he looked a little brighter himself, and not quite so pale as he had done when she found him sitting alone trying to do the new house “jestice.”

When at length they went in to supper it was almost dusk, and he had his arm still around her. He did not let her go until they sat down at the table, and then she brought her chair quite close to his, and while she ate looked at him often with her soft, wet eyes.

CHAPTER XIV.

CONFESSIONS.

THEY had a long, quiet evening together afterward. They sat before the fire, and Louisiana drew her low seat near him so that she could rest her head upon his knee.

“It’s almost like old times,” she said. “Let us pretend I never went away and that everything is as it used to be.”

“Would ye like it to be thataway, Louisianny?” he asked.

She was going to say “Yes,” but she remembered the changes he had made to please her, and she turned her face and kissed the hand her cheek rested against.

“You mustn’t fancy I don’t think the new house is beautiful,” she said. “It isn’t that I mean. What I would like to bring back is—is the feeling I used to have. That is all—nothing but the old feeling. And people can’t always have the same feelings, can they? Things change so as we get older.”

He looked at the crackling fire very hard for a minute.

“Thet’s so,” he said. “Thet’s so. Things changes in gin’ral, an’ feelin’s, now, they’re cur’us. Thar’s things as kin be altered an’ things as cayn’t—an’ feelin’s they cayn’t. They’re cur’us. Ef ye hurt ’em, now, thar’s money; it aint nowhar—it don’t do no good. Thar aint nothin’ ye kin buy as ’ll set ’em straight. Ef—fer instants—money could buy back them feelin’s of yourn—them as ye’d like to hev back—how ready an’ willin’ I’d be to trade fer ’em! Lord! how ready an’ willin’! But it wont do it. Thar’s whar it is. When they’re

gone a body hez to larn to git along without ’em.”

And they sat silent again for some time, listening to the snapping of the dry wood burning in the great fire-place.

When they spoke next it was of a different subject.

“Ef ye aint a-goin’ to Europe—” the old man began.

“And I’m not, father,” Louisiana put in.

“Ef ye aint, we must set to work fixin’ up right away. This mornin’ I was a-layin’ out to myself to let it stay tell ye come back an then hev it all ready fer ye—cheers an’ tables—an’ sophias—an’ merrors—an’—ile paintin’s. I laid out to do it slow, Louisianny, and take time, an’ stedly a heap, an’ to take advice from them es knows, afore I traded ary time. I ’lowed it’d be a heap better to take advice from them es knowed. Brown, es owns the Springs, I ’lowed to hev asked him, now,—he’s used to furnishin’ up an’ knows whar to trade an’ what to trade fer. The paintin’s, now—I’ve heern it takes a heap o’ experience to pick ’em, an’ I aint hed no experience. I ’low I shouldn’t know a good un when I seen it. Now, them picters as was in the parlor—ye know more than I do, I dessay,—now, them picters,” he said, a little uncertainly, “was they to say good, or—or only about middlin’?”

She hesitated a second.

“Mother was fond of them,” she broke out, in a burst of simple feeling.

Remembering how she had stood before the simpering, red-cheeked faces and hated them; how she had burned with shame before them, she was stricken with a bitter pang of remorse.

“Mother was fond of them,” she said.

“Thet’s so,” he answered, simply. “Thet’s so, she was; an’ you a-bein’ so soft-hearted an’ tender makes it sorter go agin ye to give in as they wasn’t—what she took ’em fer. But ye see, thet—though it’s nat’ral—it’s nat’ral—don’t make ’em good or bad, Louisianny, an’ Lord! it don’t harm *her*. Taint what folks knows or what they don’t know that makes the good in ’em. Ianthy she warn’t to say ’complished, but I don’t see how she could hev ben no better than she was—nor more calc’lated to wear well—in the p’int o’ religion. Not hevin’ experience in ile paintin’s aint what’d hurt her, nor make us think no less of her. It wouldn’t hev hurt her when she was livin’, an’ Lord! she’s past it now—she’s past it, Ianthy is.”

He talked a good deal about his plans and of the things he meant to buy. He was quite eager in his questioning her and showed such lavishness as went to her heart.

"I want to leave ye well fixed," he said.

"Leave me?" she echoed.

He made a hurried effort to soften the words.

"I'd oughtn't to said it," he said. "It was kinder keerless. 'Thet thar—it's a long way off—mebbe—an' I'd oughtn't to hev said it. It's a way old folks hev—but it's a bad way. Things git to seem sorter near to 'em—an' ordinary."

The whole day had been to Louisiana a slow approach to a climax. Sometimes when her father talked she could scarcely bear to look at his face as the firelight shone on it.

So, when she had bidden him good-night at last and walked to the door leaving him standing upon the hearth watching her as she moved away, she turned round suddenly and faced him again, with her hand upon the latch.

"Father," she cried, "I want to tell you—I want to tell you——"

"What?" he said. "What, Louisianny?"

She put her hand to her side and leaned against the door—a slender, piteous figure.

"Don't look at me kindly," she said. "I don't deserve it. I deserve nothing. I have been ashamed——"

He stopped her, putting up his shaking hand and turning pale.

"Don't say nothin' as ye'll be sorry fer when ye feel better, Louisianny," he said. "Don't git carried away by yer feelin's into sayin' nothin' es is hard on yerself. Don't ye do it, Louisianny. Thar aint no need fer it, honey. Yer kinder wrought up, now, an' ye cayn't do yerself jestic."

But she would not be restrained.

"I *must* tell you," she said. "It has been on my heart too long. I ought never to have gone away. Everybody was different from us—and had new ways. I think they laughed at me, and it made me bad. I began to ponder over things until at last I hated myself and everything, and was ashamed that I had been content. When I told you I wanted to play a joke on the people who came here, it was not true. I wanted them to go away without knowing that this was my home. It was only a queer place, to be laughed at, to them, and I was ashamed of it, and bitter and

angry. When they went into the parlor they laughed at it and at the pictures, and everything in it, and I stood by with my cheeks burning. When I saw a strange woman in the kitchen it flashed into my mind that I had no need to tell them that all these things that they laughed at had been round me all my life. They were not sneering at them—it was worse than that—they were only interested and amused and curious, and were not afraid to let me see. The—gentleman had been led by his sister to think I came from some city. He thought I was—was pretty and educated,—his equal, and I knew how amazed he would be and how he would say he could not believe that I had lived here, and wonder at me and talk me over. And I could not bear it. I only wanted him to go away without knowing, and never, never see me again!"

Remembering the pain and fever and humiliation of the past, and of that dreadful day above all, she burst into sobbing.

"You did not think I was that bad, did you?" she said. "But I was! I was!"

"Louisianny," he said, huskily, "come yere. Thar aint no need fer ye to blame yerself thataway. Yer kinder wrought up."

"Don't be kind to me!" she said. "Don't! I want to tell you all—every word! I was so bad and proud and angry that I meant to carry it out to the end, and tried to—only I was not quite bad enough for one thing, father—I was not bad enough to be ashamed of *you*, or to bear to sit by and see them cast a slight upon you. They didn't mean it for a slight—it was only their clever way of looking at things—but I loved you. You were all I had left, and I knew you were better than they were a thousand times! Did they think I would give your warm, good heart—your kind, faithful heart—for all they had learned, or for all they could ever learn? It killed me to see and hear them! And it seemed as if I was on fire. And I told them the truth—that you were *my* father and that I loved you and was proud of you—that I might be ashamed of myself and all the rest, but not of you—never of you—for I wasn't worthy to kiss your feet!"

For one moment her father watched her, his lips parted and trembling. It seemed as if he meant to try to speak, but could not. Then his eyes fell with an humble, bewildered, questioning glance upon his feet, encased in their large, substantial brogans—the feet she had said she was not worthy to

kiss. What he saw in them to touch him so it would be hard to tell—for he broke down utterly, put out his hand, groping to feel for his chair, fell into it with head bowed on his arm, and burst into sobbing too.

She left her self-imposed exile in an instant, ran to him, and knelt down to lean against him.

"Oh!" she cried, "have I broken your heart? Have I broken your heart? Will God ever forgive me? I don't ask you to forgive me, father, for I don't deserve it."

At first he could not speak, but he put his arm round her and drew her head up to his breast—and, with all the love and tenderness he had lavished upon her all her life, she had never known such love and tenderness as he expressed in this one movement.

"Louisiany," he said, brokenly, when he had found his voice, "it's you as should be a-forgivin' me."

"I!" she exclaimed.

He held her in his trembling arm so close that she felt his heart quivering.

"To think," he almost whispered, "as I should not hev ben doin' ye jestic! To think as I didn't know ye well enough to do ye jestic! To think yer own father, thet's knowed ye all yer life, could hev give in to its bein' likely as ye wasn't—what he'd allers thought, an' what yer mother 'd thought, an' what ye was, honey."

"I don't—" she began, falteringly.

"It's me as oughter be a-standin' agin the door," he said. "It's me! I knowed every word of the first part of what ye've told me, Louisiany. I've been so sot on ye thet I've got into a kinder noticin' way with ye, an' I guessed it out. I seen it in yer face when ye stood thar tryin' to laugh on the porch while them people was a-waitin'. 'Twa'n't no nat'ral gal's laugh ye laughed, and when ye thought I wasn't a-noticin' I was a-noticin' an' a-thinkin' all the time. But I seen more than was thar, honey, an' I didn't do ye jestic—an' I've ben punished fer it. It come agin me like a slung-shot. I ses to myself, 'She's ashamed o' me! It's me she's ashamed of—an' she wants to pass me off fer a stranger!'"

The girl drew off from him a little and looked up into his face wonderingly.

"You thought that!" she said. "And never told me—and humored me, and—"

"I'd oughter knowed ye better," he said; "but I've suffered fer it, Louisiany. I ses to myself, 'All the years thet we've ben sot

on each other an' nussed each other through our little sick spells, an' keered fer each other, hes gone fer nothin'. She wants to pass me off fer a stranger.' Not that I blamed ye, honey. Lord! I knowed the difference betwixt us! I'd knowed it long afore you did. But somehow it warn't eggsakly what I looked fer an' it was kinder hard on me right at the start. An' then the folks went away an' ye didn't go with 'em, an' thar was somethin' workin' on ye as I knowed ye wasn't ready to tell me about. An' I sot an' steddied it over an' watched ye, an' I prayed some, an' I laid wake nights a-steddin'. An' I made up my mind thet es I'd ben the cause o' trouble to ye I'd oughter try an' sorter balance the thing. I allers 'lowed parents hed a duty to their child'en. An' I ses, 'Thar's some things thet kin be altered an' some thet cayn't. Let's alter them es kin!'"

She remembered the words well, and now she saw clearly the dreadful pain they had expressed; they cut her to her soul.

"Oh! father," she cried. "How could you?"

"I'd oughter knowed ye better, Louisiany," he repeated. "But I didn't. I ses, 'What money an' steddin' an' watchin' ll do fer her to make up, shell be done. I'll try to make up-fer the wrong I've did her on-willin'ly—onwillin'ly.' An' I went to the Springs an' I watched an' steddied thar, an' I come home an' I watched an' steddied thar—an' I hed the house fixed, an' I laid out to let ye go to Europe—though what I'd heern o' the habits o' the people, an' the bri-gands an' sich, went powerful agin me makin' up my mind easy. An' I never lost sight nary minnit o' what I'd laid out fer to do—but I wasn't doin' ye jestic an' didn't suffer no more than I'd oughter. An' when ye stood up thar agen the door, honey, with yer tears a-streamin' an' yer eyes a-shinin', an' told me what ye'd felt an' what ye'd said about—wa'l," (delicately) "about thet thar as ye thought ye wasn't worthy to do, it set my blood a-tremblin' in my veins—an' my heart a-shakin' in my side, an' me a-goin' all over—an' I was struck all of a heap, an' knowed thet the Lord hed ben better to me than I thought, an'—an' even when I was fondest on ye, an' proudest on ye, I hadn't done ye no sort o' jestic in world—an' never could!"

There was no danger of their misunderstanding each other again. When they were calmer they talked their trouble over

simply and confidingly, holding nothing back.

"When ye told me, Louisianny," said her father, "that ye wanted nothin' but me, it kinder went agin me more than all the rest, fer I thinks, ses I to myself, 'It aint true, an' she must be a-gettin' sorter hardened to it, or she'd never said it. It seemed like it was kinder onnecessary. Lord! the onjustice I was a-doin' ye!"

They bade each other good-night again, at last.

"Fer ye're a-lookin' pale," he said. "An' I've been kinder out o' sorts myself these

last two or three weeks. My dyspepsy's bin back on me agin an' thet thar pain in my side's bin a-workin' on me. We must take keer o' ourselves, bein' es thar's on'y us two, an' we're so sot on each other."

He went to the door with her and said his last words to her there.

"I'm glad it come to-night," he said, in a grateful tone. "Lord! how glad I am it come to-night! S'posin' somethin' hed happened to ary one of us an' the other hed ben left not a-knowin' how it was. I'm glad it didn't last no longer, Louisianny."

And so they parted for the night.

(To be concluded.)

THE GRANDISSIMES.*

A STORY OF CREOLE LIFE.

By GEORGE W. CABLE, author of "Old Creole Days."

CHAPTER XXVII.

THE FÊTE DE GRANDPÈRE.

SOJOURNERS in New Orleans who take their afternoon drive down Esplanade street will notice, across on the right, between it and that sorry streak once fondly known as Champs Elysées, two or three large, old houses, rising above the general surroundings and displaying architectural features which identify them with an irrevocable past—a past when the faithful and true Creole could, without fear of contradiction, express his religious belief that the antipathy he felt for the *Américain* invader was an inborn horror laid lengthwise in his ante-natal bones by a discriminating and appreciative Providence. There is, for instance, or was until lately, one house which some hundred and fifteen years ago was the suburban residence of the old sea-captain governor, Kerlerec. It stands up among the oranges as silent and gray as a pelican, and, so far as we know, has never had one cypress plank added or subtracted since its master was called to France and thrown into the Bastille. Another has two dormer windows looking out to westward, and, when the setting sun strikes the panes, reminds one of a

man with spectacles standing up in an audience, searching for a friend who is not there and will never come back. These houses are the last remaining—if, indeed, they were not pulled down yesterday—of a group that once marked from afar the direction of the old highway between the city's walls and the suburb St. Jean. Here clustered the earlier aristocracy of the colony; all that pretty crew of counts, chevaliers, marquises, colonels, dons, etc., who loved their kings, and especially their kings' monkeys, with an *abandon* which affected the accuracy of nearly all their accounts.

Among these stood the great mother-mansion of the Grandissimes. Do not look for it now; it is quite gone. The round, white-plastered brick pillars which held the house fifteen feet up from the reeking ground and rose on loftily to sustain the great overspreading roof, or clustered in the cool, paved basement; the lofty halls, with their multitudinous glitter of gilded brass and twinkle of sweet-smelling wax-candles; the immense encircling veranda, where twenty Creole girls might walk abreast; the great front stairs, descending from the veranda to the garden, with a lofty palm on either side, on whose broad steps forty Grandissimes could gather on a

* Copyright, 1879, by George W. Cable. All rights reserved.

birthday afternoon; and the belvidere, whence you could see the cathedral, the Ursulines', the governor's mansion, and the river, far away, shining between the villas of Tchoupitoulas Coast—all have disappeared as entirely beyond recall as the flowers that bloomed in the gardens on the day of this *fête de grandpère*.

Odd to say, it was not the grandpère's birthday; that had passed. For weeks the happy children of the many Grandissime branches—the Mandarins, the St. Blancards, the Brahmins—had been standing with their uplifted arms apart, awaiting the signal to clap hands and jump, and still, from week to week, the appointed day had been made to fall back, and fall back before—what think you?—an inability to understand Honoré.

It was a sad paradox in the history of this majestic old house that her best child gave her the most annoyance; but it had long been so. Even in his early youth, a scant two years after she had watched him over the tops of her green myrtles and white and crimson oleanders, go away, a lad of fifteen, supposing he would of course come back a Grandissime of the Grandissimes—an inflexible of the inflexibles, he was found "inciting" (so the stately dames and officials who graced her front veranda called it) a Grandissime-De Grapion reconciliation by means of transatlantic letters, and reducing the flames of the old feud, rekindled by the Fusilier-Nancanou duel, to a little foul smoke. The main difficulty seemed to be that Honoré could not be satisfied with a clean conscience as to his own deeds and the peace and fellowships of single households; his longing was, and had ever been—he had inherited it from his father—to see one unbroken and harmonious Grandissime family gathering yearly under this venerated roof without reproach before all persons, classes, and races with whom they had ever had to do. It was not hard for the old mansion to forgive him once or twice; but she had had to do it often. It seems no overstretch of fancy to say she sometimes gazed down upon his erring ways with a look of patient sadness in her large and beautiful windows.

And how had that forbearance been rewarded? Take one short instance: when, seven years before this present *fête de grandpère*, he came back from Europe, and she (this old home which we cannot help but personify), though in trouble then—a trouble that sent up the old feud flames again—

opened her halls to rejoice in him with the joy of all her gathered families, he presently said such strange things in favor of indiscriminate human freedom that for very shame's sake she hushed them up, in the fond hope that he would outgrow such heresies. But he? On top of all the rest, he declined a military commission and engaged in commerce—"shop-keeping, *parbleu!*"

However, therein was developed a grain of consolation. Honoré became—as he chose to call it—more prudent. With much tact, Agricola was amiably crowded off the dictator's chair, to become, instead, a sort of seneschal. For a time the family peace was perfect, and Honoré, by a touch here to-day and a word there to-morrow, was ever lifting the name, and all who bore it, a little and a little higher; when suddenly, as in his father's day—that dear Numa who knew how to sacrifice his very soul as a sort of Iphigenia for the propitiation of the family gods—as in Numa's day came the cession to Spain, so now fell this other cession, like an unexpected tornado, threatening the wreck of her children's slave-schooners and the prostration alike of their slave-made crops and their Spanish liberties; and just in the fateful moment where Numa would have stood by her, Honoré had let go. Ah, it was bitter!

"See what foreign education does!" cried a Mandarin de Grandissime of the Baton Rouge Coast. "I am sorry now"—derisively—"that I never sent *my* boy to France, am I not? No! No-o-o! I would rather my son should never know how to read, than that he should come back from Paris repudiating the sentiments and prejudices of his own father. Is education better than family peace? Ah, bah! My son make friends with Américains and tell me they—that call a negro 'monsieur'—are as good as his father? But that is what we get for letting Honoré become a merchant. Ha! the degradation! Shaking hands with men who do not believe in the slave trade! Shake hands? Yes; associate—fraternize!—with apothecaries and negrophiles. And now we are invited to meet at the *fête de grandpère*, in the house where he is really the chief—the *caçique!*"

No! The family would not come together on the first appointment; no, nor on the second; no, nor if the grandpapa did express his wish; no, nor on the third—nor on the fourth.

"*Non, Messieurs!*" cried both youth and

reckless age; and, sometimes, also, the stronger heads of the family, the men of means, of force and of influence, urged on from behind by their proud and beautiful wives and daughters.

Arms, generally, rather than heads, ruled there in those days, and sentiments (which are the real laws) took shape in accordance with the poetry, rather than the reason, of things, and the community recognized the supreme domination of the "gentleman" in questions of right and of "the ladies" in matters of sentiment. Under such conditions strength establishes over weakness a showy protection which is the subtlest of tyrannies, yet which, in the very moment of extending its arm over woman, confers upon her a power which a truer freedom would only diminish; constitutes her in a large degree an autocrat of public sentiment and thus accepts her narrowest prejudices and most belated errors as the very need-be's of social life.

The clans classified easily into three groups: there were those who boiled, those who stewed, and those who merely steamed under a close cover. The men in the first two groups were, for the most part, those who were holding office under old Spanish commissions, and were daily expecting themselves to be displaced and Louisiana thereby ruined. The steaming ones were a goodly fraction of the family—the timid, the apathetic, the "conservative." The conservatives found ease better than exactitude, the trouble of thinking great, the agony of deciding harrowing, and the alternative of smiling cynically and being liberal so much easier—and the warm weather coming on with a rapidity wearying to contemplate.

"The Yankee was an inferior animal."

"Certainly."

"But Honoré had a right to his convictions."

"Yes, that was so, too."

"It looked very traitorous, however."

"Yes, so it did."

"Nevertheless, it might turn out that Honoré was advancing the true interests of his people."

"Very likely."

"It would not do to accept office under the Yankee government."

"Of course not."

"Yet it would never do to let the Yankees get the offices, either."

"That was true; nobody could deny that."

"If Spain or France got the country back, they would certainly remember and reward those who had held out faithfully."

"Certainly! That was an old habit with France and Spain."

"But if they did not get the country back——"

"Yes, that is so; Honoré is a very good fellow, and——"

And, one after another, under the mild coolness of Honoré's amiable disregard, their indignation trickled back from steam to water, and they went on drawing their stipends, some in Honoré's counting-room, where they held positions, some from the provisional government, which had as yet made but few changes, and some, secretly, from the cunning Casa-Calvo; for, blow the wind east or blow the wind west, the affinity of the average Grandissime for a salary abideth forever.

Then, at the right moment, Honoré made a single happy stroke, and even the hot Grandissimes, they of the interior parishes and they of Agricola's squadron, slaked and crumbled when he wrote each a letter saying that the governor was about to send them appointments, and that it would be well, if they wished to *evade* them, to write the governor at once, surrendering their present commissions. Well! Evade? They would evade nothing! Do you think they would so belittle themselves as to write to the usurper? They would submit to keep the positions first.

But the next move was Honoré's making the whole town aware of his apostasy. The great mansion, with the old grandpère sitting out in front, shivered. As we have seen, he had ridden through the Place d'Armes with the arch-usurper himself. Yet, after all, a Grandissime would be a Grandissime still; whatever he did he did openly. And wasn't that glorious—never to be ashamed of anything, no matter how bad? It was not every one who could ride with the governor.

And blood was so much thicker than vinegar that the family that would not meet either in January or February, met in the first week of March, every constituent one of them.

The feast has been eaten. The garden now is joyous with children and the veranda resplendent with ladies. From among the latter the eye quickly selects one. She is perceptibly taller than the others; she sits in their midst near the great hall entrance; and as you look at her there is no claim of

ancestry the Grandissimes can make which you would not allow. Her hair, once black, now lifted up into a glistening snow-drift, augments the majesty of a still beautiful face, while her full stature and stately bearing suggest the finer parts of Agricola, her brother. It is Madame Grandissime, the mother of Honoré.

One who sits at her left, and is very small, is a favorite cousin. On her right is her daughter, the widowed señora of José Martínez; she has wonderful black hair and a white brow as wonderful. The commanding carriage of the mother is tempered in her to a gentle dignity and calm, contrasting pointedly with the animated manners of the courtly matrons among whom she sits, and whose continuous conversation takes this direction or that at the pleasure of Madame Grandissime.

But if you can command your powers of attention, despite those children who are shouting Creole French and sliding down the rails of the front stair, turn the eye to the laughing squadron of beautiful girls, which every few minutes, at an end of the veranda, appears, wheels and disappears, and you note, as it were by flashes, the characteristics of face and figure that mark the Louisianaises in the perfection of the new-blown flower. You see that blondes are not impossible; there, indeed, are two sisters who might be undistinguishable twins but that one has blue eyes and golden hair. You note the exquisite penciling of their eyebrows, here and there some heavier and more velvety, where a less vivacious expression betrays a share of Spanish blood. As Grandissimes, you mark their tendency to exceed the medium Creole stature, an appearance heightened by the fashion of their robes. There is scarcely a rose in all their cheeks and a full red-ripeness of the lips would hardly be in keeping; but there is plenty of life in their eyes, which glance out between the curtains of their long lashes with a merry dancing that keeps time to the prattle of tongues. You are not able to get a straight look into them, and if you could you would see only your own image cast back in pitiful miniature; but you turn away and feel, as you fortify yourself with an inward smile, that they know you, you man, through and through, like a little song. And in turning, your sight is glad to rest again on the face of Honoré's mother. You see, this time, that she *is* his mother, by a charm you had overlooked, a candid, serene and lovable

smile. It is the wonder of those who see that smile that she can ever be harsh.

The playful, mock-martial tread of the delicate Creole feet is all at once swallowed up by the sound of many heavier steps in the hall, and the fathers, grandfathers, sons, brothers, uncles and nephews of the great family come out, not a man of them that cannot, with a little care, keep on his feet. Their descendants of the present day sip from shallower glasses and with less marked results.

The matrons, rising, offer the chief seat to the first comer, the great-grand sire—the oldest living Grandissime—Alciabiade, a shaken but unfallen monument of early colonial days, a browned and corrugated souvenir of De Vaudreuil's pomps, of O'Reilly's iron rule, of Galvez' brilliant wars—a man who had seen Bienville and Zephyr Grandissime. With what splendor of manner Madame Fusilier de Grandissime offers, and he accepts, the place of honor! Before he sits down he pauses a moment to hear out the companion on whose arm he has been leaning. But Théophile, a dark, graceful youth of eighteen, though he is recounting something with all the oblivious ardor of his kind, becomes instantly silent, bows with grave deference to the ladies, hands the aged forefather gracefully to his seat, and turning, recommences the recital to one who listens with the same perfect courtesy to all—his beloved cousin Honoré.

Meanwhile, the gentlemen throng out. Gallant crew! These are they who have been pausing proudly week after week in an endeavor (?) to understand the opaque motives of Numa's son.

In the middle of the veranda pauses a tall, muscular man of fifty, with the usual smooth face and an iron-gray queue. That is Colonel Agamemnon Brahmin de Grandissime, purveyor to the family's military pride, conservator of its military glory, and, after Honoré, the most admired of the name. Achille Grandissime, he that took Agricola away from Frowenfeld's shop in the carriage, essays to engage Agamemnon in conversation, and the colonel, with a glance at his kinsman's nether limbs and another at his own, and, with that placid facility with which the graver sort of Creoles take up the trivial topics of the lighter, grapples the subject of boots. A tall, bronzed, slender young man, who prefixes to Grandissime the maternal St. Blancard, asks where his wife is, is answered from a distance, throws her a kiss and sits down on a step, with Jean Baptiste

de Grandissime, a piratical-looking black-beard, above him, and Alphonse Mandarin, an olive-skinned boy, below. Valentine Grandissime, of Tchoupitoulas, goes quite down to the bottom of the steps and leans against the balustrade. He is a large, broad-shouldered, well-built man, and, as he stands smoking a cigar, with his black-stockinged legs crossed, he glances at the sky with the eye of a hunter—or, it may be, of a sailor.

"Valentine will not marry," says one of two ladies who lean over the rail of the veranda above. "I wonder why."

The other fixes on her a meaning look, and she twitches her shoulders and pouts, seeing she has asked a foolish question, the answer to which would only put Valentine in a numerous class and do him no credit.

Such were the choice spirits of the family. Agricola had retired. Raoul was there; his pretty auburn head might have been seen about half-way up the steps, close to one well sprinkled with premature gray.

"No such thing!" exclaimed his companion.

(The conversation was entirely in Creole French.)

"I give you my sacred word of honor!" cried Raoul.

"That Honoré is having all his business carried on in English?" asked the incredulous Sylvestre. (Such was his name.)

"I swear—" replied Raoul, resorting to his favorite pledge—"on a stack of bibles that high!"

"Ah-h-h-h, pf-f-f-f-f-f!"

This polite expression of unbelief was further emphasized by a spasmodic flirt of one hand, with the thumb pointed outward.

"Ask him! ask him!" cried Raoul.

"Honoré!" called Sylvestre, rising up. Two or three persons passed the call around the corner of the veranda.

Honoré came with a chain of six girls on either arm. By the time he arrived, there was a Babel of discussion.

"Raoul says you have ordered all your books and accounts to be written in English," said Sylvestre.

"Well?"

"It is not true, is it?"

"Yes."

The entire veranda of ladies raised one long-drawn, deprecatory "Ah!" except Honoré's mother. She turned upon him a look of silent but intense and indignant disappointment.

"Honoré!" cried Sylvestre, desirous of repairing his defeat, "Honoré!"

But Honoré was receiving the clamorous abuse of the two half dozens of girls.

"Honoré!" cried Sylvestre again, holding up a torn scrap of writing-paper which bore the marks of the floor and a boot-heel, "how do you spell 'la-dee?'"

There was a moment's hush to hear the answer.

"Ask Valentine," said Honoré.

Everybody laughed aloud. That taciturn man's only retort was to survey the company above him with an unmoved countenance, and to push the ashes slowly from his cigar with his little finger. M. Valentine Grandissime, of Tchoupitoulas, could not read.

"Show it to Agricola," cried two or three, as that great man came out upon the veranda, heavy-eyed, and with tumbled hair.

Sylvestre, spying Agricola's head beyond the ladies, put the question.

"How is it spelled on that paper?" retorted the king of beasts.

"L-a-y——"

"Ignoramus!" growled the old man.

"I did not spell it," cried Raoul, and attempted to seize the paper. But Sylvestre throwing his hand behind him, a lady snatched the paper, two or three cried "Give it to Agricola!" and a pretty boy, whom the laughter and excitement had lured from the garden, scampered up the steps and handed it to the old man.

"Honoré!" cried Raoul, "it must not be read. It is one of your private matters."

But Raoul's insinuation that anybody would entrust him with a private matter brought another laugh.

Honoré nodded to his uncle to read it out, and those who could not understand English, as well as those who could, listened. It was the paper Sylvestre had picked out of the waste-basket. Agricola read:

"What is that layde want in thare with Honoré?"

"Honoré is goin giv her bac that propety—that is Aurore DeGraption what Agricola kill the husband."

That was the whole writing, but Agricola never finished. He was reading aloud—"that is Aurore DeGrap——"

At that he dropped the paper and blackened with wrath; a sharp flash of astonishment ran through the company; an instant

of silence followed and Agricola's thundering voice rolled down upon Sylvestre in a succession of terrible imprecations.

It was painful to see the young man's face as speechless he received this abuse. He stood pale and frightened, with a smile playing about his mouth, half of distress and half of defiance, that said as plain as a smile could say, "Uncle Agricola, you will have to pay for this mistake."

As the old man ceased, Sylvestre turned and cast a look downward to Valentine Grandissime; then walked up the steps and passing with a courteous bow through the group that surrounded Agricola, went into the house. Valentine looked at the zenith, then at his shoe-buckles, tossed his cigar quietly into the grass and passed around a corner of the house to meet Sylvestre in the rear.

Honoré had already nodded to his uncle to come aside with him, and Agricola had done so. The rest of the company, save a few male figures down in the garden, after some feeble efforts to keep up their spirits on the veranda, remarked the growing coolness or the waning daylight, and singly or in pairs withdrew. It was not long before Raoul, who had come up upon the veranda, was left alone. He seemed to wait for something, as, leaning over the rail while the stars came out, he sang to himself, in a soft undertone, a snatch of a Creole song:

"La pluie—la pluie tombait,
Crapaud criait,
Moustique chantait——"

The moon shone so brightly that the children in the garden did not break off their hide-and-seek, and now and then Raoul suspended the murmur of his song, absorbed in the fate of some little elf gliding from one black shadow to crouch in another. He was himself in the deep shade of a magnolia, over whose outer boughs the moonlight was trickling, as if the whole tree had been dipped in quicksilver.

In the broad walk running down to the garden gate some six or seven dark forms sat in chairs, not too far away for the light of their cigars to be occasionally seen and their voices to reach his ear; but he did not listen. In a little while there came a light footstep and a soft, mock-startled "Who is that?" and one of that same sparkling group of girls that had lately hung upon Honoré came so close to Raoul, in her attempt to discern his lineaments, that their lips accidentally met. They had but a

moment of hand-in-hand converse before they were hustled forth by a feminine scouting party and thrust along into one of the great rooms of the house, where the youth and beauty of the Grandissimes were gathered in an expansive semicircle around a languishing fire, waiting to hear a story, or a song, or both, or half a dozen of each, from that master of narrative and melody, Raoul Innerarity.

"But mark," they cried unitedly, "you have got to wind up with the story of Bras-Coupé!"

"A song! A song!"

"*Une chanson Créole! Une chanson des nègres!*"

"Sing 'Yé tolé dancé la doung y doung doung!'" cried a black-eyed girl.

Raoul explained that it had too many objectionable phrases.

"Oh, just hum the objectionable phrases and go right on."

But instead he sang them this:



"*La premier' fois mo té 'oir li,
Li té 'posé au bord so lit;
Mo di', Bouzon, bel n'amourèse!
L'aut' fois li té 'si' so la saise
Comme vié Madam dans so fauteil,
Quand li vivé côté soleil.
So giés yé té plis noir passé la nouitte,
So dé la lev' plis doux passe la quitte!
Tou' mo la vie, zamein mo oir
Ein n'amourèse zoli comme ça!*

*Mo' blié manzé—mo' blié boir—
Mo' blié tout dipi ç' temps-là—
Mo' blié parlé—mo' blié dormi,
Quand mo pensé après zami!"*

"And you have heard Bras-Coupé sing that, yourself?"

"Once upon a time," said Raoul, warming with his subject, "we were coming down from Pointe Macarty in three pirogues. We had been three days fishing and hunting in Lake Salvador. Bras-Coupé had one pirogue with six paddles——"

"Oh, yes!" cried a youth named Baltazar; "sing that, Raoul!"

And he sang that.

"But oh, Raoul, sing that song the negroes sing when they go out in the bayous at night, stealing pigs and chickens!"

"That boat song, do you mean, which they sing as a signal to those on shore?" He hummed:

"Dé zabs, dé zabs, dé counou ouaïe ouaïe,
Dé zabs, dé zabs, dé counou ouaïe ouaïe,
Counou ouaïe ouaïe ouaïe ouaïe,
Counou ouaïe ouaïe ouaïe ouaïe,
Counou ouaïe ouaïe ouaïe, momza.
Momza, momza, momza, momza,
Roza, roza, roza-et—momza."

This was followed by another and still another, until the hour began to grow late. And then they gathered closer round him and heard the promised story. At the same hour, Honoré Grandissime, wrapping himself in a great-coat and giving himself up to sad and somewhat bitter reflections, had wandered from the paternal house, and by and by from the grounds, not knowing why or whither, but after a time soliciting, at Frowenfeld's closing door, the favor of his company. He had been feeling a kind of suffocation. This it was that made him seek and prize the presence and hand-grasp of the inexperienced apothecary. He led him out to the edge of the river. Here they sat down, and with a laborious attempt at a hard and jesting mood, Honoré told the same dark story.

CHAPTER XXVIII.

THE STORY OF BRAS-COUPÉ.

"A VERY little more than eight years ago," began Honoré—but not only Honoré, but Raoul also; and not only they, but another, earlier on the same day,—Honoré, the f. m. c. But we shall not exactly follow the words of any one of these.

Bras-Coupé, they said, had been, in Africa and under another name, a prince among his people. In a certain war of conquest, to which he had been driven by *ennui*, he was captured, stripped of his royalty, marched down upon the beach of the Atlantic, and, attired as a true son of Adam, with two goodly arms intact, became a commodity. Passing out of first hands in barter for a looking-glass, he was shipped in good order and condition on board the good schooner *Egalité*, whereof Blank was master, to be delivered without delay at the port of Nou-

velle Orleans (the dangers of fire and navigation excepted), unto Blank Blank. In witness whereof, He that made men's skins of different colors, but all blood of one, hath entered the same upon His book, and sealed it to the day of judgment.

Of the voyage little is recorded—here below; the less the better. Part of the living merchandise failed to keep; the weather was rough, the cargo large, the vessel small. However, the captain discovered there was room over the side, and there—all flesh is grass—from time to time during the voyage he jettisoned the unmerchantable.

Yet, when the re-opened hatches let in the sweet smell of the land, Bras-Coupé had come to the upper—the favored—the buttered side of the world; the anchor slid with a rumble of relief down through the muddy fathoms of the Mississippi, and the prince could hear through the schooner's side the savage current of the river, leaping and licking about the bows, and whimpering low welcomes home. A splendid picture to the eyes of the royal captive, as his head came up out of the hatchway, was the little Franco-Spanish-American city that lay on the low, brimming bank. There were little forts that showed their white-washed teeth; there was a green parade-ground, and yellow barracks, and cabildo, and hospital, and cavalry stables, and custom-house, and a most inviting jail, convenient to the cathedral—all of dazzling white and yellow, with a black stripe marking the track of the conflagration of 1794, and here and there among the low roofs a lofty one with round-topped dormer windows and a breezy belvedere looking out upon the plantations of coffee and indigo beyond the town.

When Bras-Coupé staggered ashore, he stood but a moment among a drove of "likely boys," before Agricola Fusilier, managing the business adventures of the Grandissime estate, as well as the residents therein, and struck with admiration for the physical beauties of the chieftain (a man may even fancy a negro—as a negro), bought the lot, and loth to resell him with the rest to some unappreciative 'Cadian, induced Don José Martinez' overseer to become his purchaser.

Down in the rich parish of St. Bernard (whose boundary line now touches that of the distended city) lay the plantation, known before Bras-Coupé passed away, as La Renaissance. Here it was that he entered at once upon a chapter of agreeable sur-

prises. He was humanely met, presented with a clean garment, lifted into a cart drawn by oxen, taken to a whitewashed cabin of logs, finer than his palace at home, and made to comprehend that it was a free gift. He was also given some clean food, whereupon he fell sick. At home it would have been the part of piety for the magnate next the throne to launch him heavenward at once; but now, healing doses were administered, and to his amazement he recovered. It reminded him that he was no longer king.

His name, he replied to an inquiry touching that subject, was ———, something in the Jaloff tongue, which he by and by condescended to render into Congo: Mioko-Koanga, in French Bras-Coupé, The Arm Cut Off. Truly it would have been easy to admit, had this been his meaning, that his tribe, in losing him, had lost its strong right arm close off at the shoulder; not so easy for his high-paying purchaser to allow, if this other was his intent; that the arm which might no longer shake the spear or swing the wooden sword, was no better than a useless stump never to be lifted for aught else. But whether easy to allow or not, that was his meaning. He made himself a type of all Slavery, turning into flesh and blood the truth that all Slavery is maiming.

He beheld more luxury in a week than all his subjects had seen in a century. Here Congo girls were dressed in cottons and flannels worth, where he came from, an elephant's tusk apiece. Everybody wore clothes—children and lads alone excepted. Not a lion had invaded the settlement since his immigration. The serpents were as nothing; an occasional one coming up through the floor—that was all. True, there was more emaciation than unassisted conjecture could explain—a profusion of enlarged joints and diminished muscles, which, thank God, was even then confined to a narrow section and disappeared with Spanish rule. He had no experimental knowledge of it; nay, regular meals, on the contrary, gave him anxious concern, yet had the effect—spite of his apprehension that he was being fattened for a purpose—of restoring the herculean puissance which formerly in Africa had made him the terror of the battle.

When one day he had come to be quite himself, he was invited out into the sunshine, and escorted by the driver (a sort of foreman to the overseer), went forth dimly wondering. They reached a field where

some men and women were hoeing. He had seen men and women—subjects of his—labor—a little—in Africa. The driver handed him a hoe; he examined it with silent interest—until by signs he was requested to join the pastime.

“What?”

He spoke, not with his lips, but with the recoil of his splendid frame and the ferocious expansion of his eyes. This invitation was a cataract of lightning leaping down an ink-black sky. In one instant of all-pervading clearness he read his sentence—*WORK*.

Bras-Coupé was six feet five. With a sweep as quick as instinct the back of the hoe smote the driver full in the head. Next, the prince lifted the nearest Congo crosswise, brought thirty-two teeth together in his wildly-kicking leg and cast him away as a bad morsel; then, throwing another into the branches of a willow, and a woman over his head into a draining-ditch, he made one bound for freedom, and fell to his knees, rocking from side to side under the effect of a pistol-ball from the overseer. It had struck him in the forehead, and running around the skull in search of a penetrable spot, tradition—which sometimes jests—says came out despairingly, exactly where it had entered.

It so happened that, except the overseer, the whole company were black. Why should the trivial scandal be blabbed? A plaster or two made everything even in a short time, except in the driver's case—for the driver died. The woman whom Bras-Coupé had thrown over his head lived to sell calas to Joseph Frowenfeld.

Don José, young and austere, knew nothing about agriculture and cared as much about human nature. The overseer often thought this, but never said it; he would not trust even himself with the dangerous criticism. When he ventured to reveal the foregoing incidents to the señor he laid all the blame possible upon the man whom death had removed beyond the reach of correction, and brought his account to a climax by hazarding the assertion that Bras-Coupé was an animal that could not be whipped.

“Caramba!” exclaimed the master, with gentle emphasis, “how so?”

“Perhaps señor had better ride down to the quarters,” replied the overseer.

It was a great sacrifice of dignity, but the master made it.

“Bring him out.”

They brought him out—chains on his feet, chains on his wrists, an iron yoke on his

neck. The Spanish-Creole master had often seen the bull, with his long, keen horns and blazing eye, standing in the arena; but this was as though he had come face to face with a rhinoceros.

"This man is not a Congo," he said.

"He is a Jaloff," replied the encouraged overseer. "See his fine, straight nose; moreover, he is a *candio*—a prince. If I whip him he will die."

The dauntless captive and fearless master stood looking into each other's eyes until each recognized in the other his peer in physical courage, and each was struck with an admiration for the other which no after difference was sufficient entirely to destroy. Had Bras-Coupé's eye quailed but once—just for one little instant—he would have got the lash; but, as it was —

"Get an interpreter," said Don José; then, more privately, "and come to an understanding. I shall require it of you."

Where might one find an interpreter— one not merely able to render a Jaloff's meaning into Creole French or Spanish, but with such a turn for diplomatic correspondence as would bring about an "understanding" with this African buffalo? The overseer was left standing and thinking, and Clemence, who had not forgotten who threw her into the draining-ditch, cunningly passed by.

"Ah, Clemence —"

"*Mo pas capabe! Mo pas capabe!* (I cannot, I cannot!) *Ya, ya, ya!* 'oir *Miché Agricola Fusilier! ouala yune bon monture, oui!*"—which was to signify that Agricola could interpret the very Papa Lébat.

"Agricola Fusilier! The last man on earth to make peace."

But there seemed to be no choice, and to Agricola the overseer went. It was but a little ride to the Grandissime place.

"I, Agricola Fusilier, stand as interpreter to a negro? H-sir!"

"But I thought you might know of some person," said the weakening applicant, rubbing his ear with his hand.

"Ah!" replied Agricola, addressing the surrounding scenery, "if I did not—who would? You may take Palmyre."

The overseer softly smote his hands together at the happy thought.

"Yes," said Agricola, "take Palmyre; she has picked up as many negro dialects as I know European languages."

And she went to the don's plantation as interpretress, followed by Agricola's prayer to Fate that she might in some way be over-

taken by disaster. The two hated each other with all the strength they had. He knew not only her pride, but her passion for the absent Honoré. He hated her, also, for her intelligence, for the high favor in which she stood with her mistress, and for her invincible spirit, which was more offensively patent to him than to others, since he was himself the chief object of her silent detestation.

It was Palmyre's habit to do nothing without painstaking. "When Mademoiselle comes to be Señora," thought she—she knew that her mistress and the don were affianced—"it will be well to have Señor's esteem. I shall endeavor to succeed." It was from this motive, then, that with the aid of her mistress she attired herself in a resplendence of scarlet and beads and feathers that could not fail the double purpose of connecting her with the children of Ethiopia and commanding the captive's instant admiration.

Alas for those who succeed too well! No sooner did the African turn his tiger glance upon her than the fire of his eyes died out; and when she spoke to him in the dear accents of his native tongue, the matter of strife vanished from his mind. He loved.

He sat down tamely in his irons and listened to Palmyre's argument as a wrecked mariner would listen to ghostly church-bells. He would give a short assent, feast his eyes, again assent, and feast his ears; but when at length she made bold to approach the actual issue, and finally uttered the loathed word, *Work*, he rose up, six feet five, a statue of indignation in black marble.

And then Palmyre, too, rose up, glorying in him, and went to explain to master and overseer. Bras-Coupé understood, she said, that he was a slave—it was the fortune of war, and he was a warrior; but, according to a generally recognized principle in African international law, he could not reasonably be expected to work.

"As señor will remember I told him," remarked the overseer; "how can a man expect to plow with a zebra?"

Here he recalled a fact in his early experience. An African of this stripe had been found to answer admirably as a "driver" to make others work. A second and third parley, extending through two or three days, were held with the prince, looking to his appointment to the vacant office of driver; yet what was the master's amazement to learn at length that his Highness declined the proffered honor.

"Stop!" spoke the overseer again, detecting a look of alarm in Palmyre's face as she turned away, "he doesn't do any such thing. If Señor will let me take the man to Agricola——"

"No!" cried Palmyre, with an agonized look, "I will tell. He will take the place and fill it if you will give me to him for his own—but oh, messieurs, for the love of God—I do not want to be his wife!"

The overseer looked at the Señor, ready to approve whatever he should decide. Bras-Coupé's intrepid audacity took the Spaniard's heart by irresistible assault.

"I leave it entirely with Señor Fusilier," he said.

"But he is not my master; he has no right——"

"Silence!"

And she was silent; and so, sometimes, is fire in the wall.

Agricola's consent was given with malicious promptness, and as Bras-Coupé's fetters fell off it was decreed that, should he fill his office efficiently, there should be a wedding on the rear veranda of the Grandissime mansion simultaneously with the one already appointed to take place in the grand hall of the same house six months from that present day. In the meanwhile Palmyre should remain with Mademoiselle, who had promptly but quietly made up her mind that Palmyre should not be wed unless she wished to be. Bras-Coupé made no objection, was royally worthless for a time, but learned fast, mastered the "gumbo" dialect in a few weeks, and in six months was the most valuable man ever bought for gourde dollars. Nevertheless, there were but three persons within as many square miles who were not most vividly afraid of him.

The first was Palmyre. His bearing in her presence was ever one of solemn, exalted respect, which, whether from pure magnanimity in himself, or by reason of her magnetic eye, was something worth being there to see. "It was royal!" said the overseer.

The second was not that official. When Bras-Coupé said—as, at stated intervals, he did say—"Mo courri d'ez Agricole Fusilier 'pou' oir' n amoureuse (I go to Agricola Fusilier to see my betrothed)," the overseer would sooner have intercepted a score of painted Chickasaws than that one lover. He would look after him and shake a prophetic head. "Trouble coming; better not deceive that fellow;" yet that was the very

thing Palmyre dared do. Her admiration for Bras-Coupé was almost boundless. She rejoiced in his stature; she reveled in the contemplation of his untamable spirit; he seemed to her the gigantic embodiment of her own dark, fierce will, the expanded realization of her life-time longing for terrible strength. But the single deficiency in all this impassioned regard was—what so many fairer loves have found impossible to explain to so many gentler lovers—an entire absence of preference; her heart she could not give him—she did not have it. Yet after her first prayer to the Spaniard and his overseer for deliverance, to the secret surprise and chagrin of her young mistress, she simulated content. It was artifice; she knew Agricola's power, and to seem to consent was her one chance with him. He might thus be beguiled into withdrawing his own consent. That failing, she had Mademoiselle's promise to come to the rescue, which she could use at the last moment; and that failing, there was a dirk in her bosom, for which a certain hard breast was not too hard. Another element of safety, of which she knew nothing, was a letter from the Cannes Brulée. The word had reached there that love had conquered—that, despite all hard words, and rancor, and positive injury, the Grandissime hand—the fairest of Grandissime hands—was about to be laid into that of one who without much stretch might be called a De Grapion; that there was, moreover, positive effort being made to induce a restitution of old gaming-table spoils. Honoré and Mademoiselle, his sister, one on each side of the Atlantic, were striving for this end. Don José sent this intelligence to his kinsman as glad tidings (a lover never imagines there are two sides to that which makes him happy) and, to add a touch of humor, told how Palmyre, also, was given to the chieftain. The letter that came back to the young Spaniard did not blame him so much: he was ignorant of all the facts; but a very formal one to Agricola begged to notify him that if Palmyre's union with Bras-Coupé should be completed, as sure as there was a God in heaven, the writer would have the life of the man who knowingly had thus endeavored to dishonor one who shared the blood of the De Grapions. Thereupon Agricola, contrary to his general character, began to drop hints to Don José that the engagement of Bras-Coupé and Palmyre need not be considered irreversible; but the don was not desirous of disap-

pointing his terrible pet. Palmyre, unluckily, played her game a little too deeply. She thought the moment had come for herself to insist on the match, and thus provoke Agricola to forbid it. To her incalculable dismay she saw him a second time reconsider and become silent.

The second person who did not fear Bras-Coupé was Mademoiselle. On one of the giant's earliest visits to see Palmyre he obeyed the summons which she brought him, to appear before the lady. A more artificial man might have objected on the score of dress, his attire being a single gaudy garment tightly enveloping the waist and thighs. As his eyes fell upon the beautiful white lady he prostrated himself upon the ground, his arms outstretched before him. He would not move till she was gone. Then he rose like a hermit who has seen a vision. "*Bras-Coupé n' pas oulé oir zombis* (Bras-Coupé dares not look upon a spirit)." From that hour he worshipped. He saw her often; every time, after one glance at her countenance, he would prostrate his gigantic length with his face in the dust.

The third person who did not fear him, was—Agricola? Nay, it was the Spaniard—a man whose capability to fear anything in nature or beyond had never been discovered.

Long before the end of his probation Bras-Coupé would have slipped the entanglements of bondage, though as yet he felt them only as one feels a spider's web across the face, had not the master, according to a little affectation of the times, promoted him to be his game-keeper. Many a day did these two living magazines of wrath spend together in the dismal swamps and on the meager intersecting ridges, making war upon deer and bear and wildcat; or on the Mississippi after wild goose and pelican; when even a word misplaced would have made either the slayer of the other. Yet the months ran smoothly round and the wedding night drew nigh.* A goodly company had assembled. All things were ready. The bride was dressed, the bridegroom had come. On the great back piazza, which had been inclosed with sail-cloth and lighted

* An over-zealous Franciscan once complained bitterly to the bishop of Havana, that people were being married in Louisiana in their own houses after dark and thinking nothing of it. It is not certain that he had reference to the Grandissime mansion; at any rate he was tittered down by the whole community.

with lanterns, was Palmyre, full of a new and deep design and playing her deceit to the last, robed in costly garments to whose beauty was added the charm of their having been worn once, and once only, by her beloved Mademoiselle.

But where was Bras-Coupé?

The question was asked of Palmyre by Agricola with a gaze that meant in English, "No tricks, girl!"

Among the servants who huddled at the windows and doors to see the inner magnificence a frightened whisper was already going round.

"We have made a sad discovery, Miché Fusilier," said the overseer. "Bras-Coupé is here; we have him in a room just yonder. But—the truth is, sir, Bras-Coupé is a voodoo."

"Well, and suppose he is; what of it? Only hush; do not let his master know it. It is nothing; all the blacks are voodoo, more or less."

"But he declines to dress himself—has painted himself all rings and stripes, antelope fashion."

"Tell him Agricola Fusilier says, 'dress immediately!'"

"Oh, Miché, we have said that five times already, and his answer—you will pardon me—his answer is—spitting on the ground—that you are a contemptible *dotchian* (white trash)."

There is nothing to do but privily to call the very bride—the lady herself. She comes forth in all her glory, small, but oh, so beautiful! Slam! Bras-Coupé is upon his face, his finger-tips touching the tips of her snowy slippers. She gently bids him go and dress, and at once he goes.

Ah! now the question may be answered without whispering. There is Bras-Coupé, towering above all heads, in ridiculous red and blue regimentals, but with a look of savage dignity upon him that keeps every one from laughing. The murmur of admiration that passed along the thronged gallery leaped up into a shout in the bosom of Palmyre. Oh, Bras-Coupé—heroic soul! She would not falter. She would let the silly priest say his say—then her cunning should help her *not to be* his wife, yet to show his mighty arm how and when to strike.

"He is looking for Palmyre," said some, and at that moment he saw her.

"Ho-o-o-o-o!"

Agricola's best roar was a penny trumpet to Bras-Coupé's note of joy. The whole

masculine half of the in-door company flocked out to see what the matter was. Bras-Coupé was taking her hand in one of his and laying his other upon her head; and as some one made an unnecessary gesture for silence, he sang, beating slow and solemn time with his naked foot and with the hand that dropped hers to smite his breast:

“*En haut la montagne, zami,
Mo pé coupé canne, zami,
Pou' fé l'â'zen' zami,
Pou' mo baille Palmyre.
Ah! Palmyre, Palmyre mo c'ere,
Mo l'aimé 'ou'—mo l'aimé 'ou'.*”

“*Montagne?*” asked one slave of another, “*qui ci cà, montagne? gnia pas quic' ose comme cà dans la Louisiana?*” (What's a mountain? We haven't such things in Louisiana.)

“*Mein ye gagnein plein montagnes dans l'Afrique, listen!*”

“*Ah! Palmyre, Palmyre, mo' piti zozo,
Mo l'aimé 'ou'—mo l'aimé l'aimé 'ou'.*”

“Bravissimo!”—but just then a counter-attraction drew the white company back into the house. An old French priest with sandaled feet and a dirty face had arrived. There was a moment of hand-shaking with the good father, then a moment of palpitation and holding of the breath, and then—you would have known it by the turning away of two or three feminine heads in tears—the lily hand became the don's, to have and to hold, by authority of the Church and the Spanish king. And all was merry, save that outside there was coming up as villainous a night as ever cast black looks in through snug windows.

It was just as the newly wed Spaniard, with Agricola and all the guests, were concluding the by-play of marrying the darker couple, that the hurricane struck the dwelling. The holy and jovial father had made faint pretense of kissing this second bride; the ladies, colonels, dons, etc.,—though the joke struck them as a trifle coarse—were beginning to laugh and clap hands again and the gowned jester to bow to right and left, when Bras-Coupé, tardily realizing the consummation of his hopes, stepped forward to embrace his wife.

“Bras-Coupé!”

The voice was that of Palmyre's mistress. She had not been able to comprehend her maid's behavior, but now Palmyre had darted upon her an appealing look.

The warrior stopped as if a javelin had flashed over his head and stuck in the wall.

“Bras-Coupé must wait till I give him his wife.”

He sank, with hidden face, slowly to the floor.

“Bras-Coupé hears the voice of zombis; the voice is sweet, but the words are very strong; and the same sugar-cane comes *sirof* and *tafia*; Bras-Coupé says to zombis, ‘Bras-Coupé will wait; but if the *dotchians* deceive Bras-Coupé—” he rose to his feet with his eyes closed and his great black fist lifted over his head—“Bras-Coupé will call *Voudou-Magnan!*”

The crowd retreated and the storm fell like a burst of infernal applause. A whiff like fifty witches flouted up the canvas curtain of the gallery and a fierce black cloud, drawing the moon under its cloak, belched forth a stream of fire that seemed to flood the ground; a peal of thunder followed as if the sky had fallen in, the house quivered, the great oaks groaned, and every lesser thing bowed down before the awful blast. Every lip held its breath for a minute—or an hour, no one knew—there was a sudden lull of the wind, and the floods came down. Have you heard it thunder and rain in those Louisiana lowlands? Every clap seems to crack the world. It has rained a moment; you peer through the black pane—your house is an island, all the land is sea.

However, the supper was spread in the hall and in due time the guests were filled. Then a supper was spread in the big hall in the basement, below stairs, the sons and daughters of Ham came down like the fowls of the air upon a rice-field, and Bras-Coupé, throwing his heels about with the joyous carelessness of a smutted Mercury, for the first time in his life tasted the blood of the grape. A second, a fifth, a tenth time he tasted it, drinking more deeply each time, and would have taken it ten times more had not his bride cunningly concealed it. It was like stealing a tiger's kittens.

The moment quickly came when he wanted his eleventh bumper. As he presented his request a silent shiver of consternation ran through the dark company; and when, in what the prince meant as a remonstrative tone, he repeated the petition—splitting the table with his fist by way of punctuation—there ensued a hustling up staircases and a cramming into dim corners that left him alone at the banquet.

Leaving the table, he strode upstairs and into the chirruping and dancing of the grand salon. There was a halt in the cotillion

and a hush of amazement like the shutting off of steam. Bras-Coupé strode straight to his master, laid his paw upon his fellow-bridegroom's shoulder and in a thunder-tone demanded:

"More!"

The master swore a Spanish oath, lifted his hand and—fell, beneath the terrific fist of his slave, with a bang that jingled the candelabras. Dolorous stroke!—for the dealer of it. Given, apparently to him—poor, tipsy savage—in self-defense, punishable, in a white offender, by a small fine or a few days' imprisonment, it assured Bras-Coupé the death of a felon; such was the old *Code Noir*. (We have a *Code Noir* now, but the new one is a mental reservation, not an enactment.)

The guests stood for an instant as if frozen, smitten stiff with the instant expectation of insurrection, conflagration and rapine (just as we do to-day whenever some poor swaggering Pompey rolls up his fist and gets a ball through his body), while, single-handed and naked-fisted in a roomful of swords, the giant stood over his master, making strange signs and passes and rolling out in wrathful words of his mother tongue what it needed no interpreter to tell his swarming enemies was a voodoo malediction.

"*Nous sommes grigris!*" screamed two or three ladies, "we are bewitched!"

"Look to your wives and daughters!" shouted a Brahmin-Mandarin.

"Shoot the black devils without mercy!" cried a Mandarin-Fusilier, unconsciously putting into a single outflash of words the whole Creole treatment of race troubles.

With a single bound Bras-Coupé reached the drawing-room door; his gaudy regimentals made a red and blue streak down the hall; there was a rush of frilled and powdered gentlemen to the rear veranda, an avalanche of lightning with Bras-Coupé in the midst making for the swamp, and then all without was blackness of darkness and all within was a wild commingled chatter of Creole, French and Spanish tongues,—in the midst of which the reluctant Agricola returned his dress-sword to its scabbard.

While the wet lanterns swung on crazily in the trees along the way by which the bridegroom was to have borne his bride; while Madame Grandissime prepared an impromptu bridal-chamber; while the Spaniard bathed his eye and the blue gash on his cheek-bone; while Palmyre paced her

room in a fever and wild tremor of conflicting emotions throughout the night and the guests splashed home after the storm as best they could, Bras-Coupé was practically declaring his independence on a slight rise of ground hardly sixty feet in circumference and lifted scarce above the water in the inmost depths of the swamp.

And what surroundings! Endless colonnades of cypresses; long, motionless drapings of gray moss; broad sheets of noisome waters, pitchy black, resting on bottomless ooze; cypress knees studding the surface; patches of floating green, gleaming brilliantly here and there; yonder where the sunbeams wedge themselves in, constellations of water-lilies, the many-hued iris, and a multitude of flowers that no man had named; here, too, serpents great and small, of wonderful colorings, and the dull and loathsome moccasin sliding warily off the dead tree; in dimmer recesses the cow alligator, with her nest hard by; turtles a century old; owls and bats, raccoons, opossums, rats, centipedes and creatures of like vileness; great vines of beautiful leaf and scarlet fruit in deadly clusters; maddening mosquitoes, parasitic insects, gorgeous dragon-flies and pretty water-lizards; the blue heron, the snowy crane, the red-bird, the moss-bird, the night-hawk and the chuck-will's-widow; a solemn stillness and stifed air only now and then disturbed by the call or whirl of the summer-duck, the dismal ventriloquous note of the rain-crow, or the splash of a dead branch falling into the clear but lifeless bayou.

The pack of Cuban hounds that howl from Don José's kennels cannot snuff the trail of the stolen canoe that glides through the somber blue vapors of the African's fastnesses. His arrows send no tell-tale reverberations to the distant clearing. Many a wretch in his native wilderness has Bras-Coupé himself, in palmier days, driven to just such an existence, to escape the chains and horrors of the barracoons; therefore not a whit broods he over man's inhumanity, but, taking the affair as a matter of course, casts about him for a future.

CHAPTER XXIX.

THE STORY OF BRAS-COUPÉ, CONTINUED.

BRAS-COUPÉ let the autumn pass, and wintered in his den.

Don José, in a majestic way, endeavored

to be happy. He took his señora to his hall, and under her rule it took on for a while a look and feeling which turned it from a hunting-lodge into a home. Wherever the lady's steps turned—or it is as correct to say wherever the proud tread of Palmyre turned—the features of bachelor's hall disappeared; guns, dogs, oars, saddles, nets, went their way into proper banishment, and the broad halls and lofty chambers—the floors now muffled with mats of palmetto-leaf—no longer re-echoed the tread of a lonely master, but breathed a redolence of flowers and a rippling murmur of well-contented song.

But the song was not from the throat of Bras-Coupé's "*piti zozo*." Silent and severe by day, she moaned away whole nights heaping reproaches upon herself for the impulse—now to her, because it had failed, inexplicable in its folly—which had permitted her hand to lie in Bras-Coupé's and the priest to bind them together.

For in the audacity of her pride, or, as Agricola would have said, in the immensity of her impudence, she had held herself consecrate to a hopeless love. But now she was a black man's wife! and even he unable to sit at her feet and learn the lesson she had hoped to teach him. She had heard of San Domingo, and for months the fierce heart within her silent bosom had been leaping and shouting and seeing visions of fire and blood, and when she brooded over the nearness of Agricola and the remoteness of Honoré these visions got from her a sort of mad consent. The lesson she would have taught the giant was Insurrection. But it was too late. Letting her dagger sleep in her bosom, and with an undefined belief in imaginary resources, she had consented to join hands with her giant hero before the priest; and when the wedding had come and gone, like a white sail, she was seized with a lasting, fierce despair. A wild aggressiveness that had formerly characterized her glance in moments of anger—moments which had grown more and more infrequent under the softening influence of her Mademoiselle's nature—now came back intensified and blazed in her eye perpetually. Whatever her secret love may have been in kind, its sinking beyond hope below the horizon had left her fifty times the mutineer she had been before—the mutineer who has nothing to lose.

"She loves her *candio*," said the negroes.

"Simple creatures!" said the overseer, who prided himself on his discernment,

"she loves nothing; she hates Agricola; it's a case of hate at first sight—the strongest kind."

Both were right; her feelings were wonderfully knit to the African; and she now dedicated herself to Agricola's ruin.

The señor, it has been said, endeavored to be happy; but now his heart conceived and brought forth its first-born fear, sired by superstition—the fear that he was bewitched. The negroes said that Bras-Coupé had cursed the land. Morning after morning the master looked out with apprehension toward his fields, until one night the worm came upon the indigo and between sunset and sunrise every green leaf had been eaten up, and there was nothing left for either insect or apprehension to feed upon.

And then he said—and the echo came back from the Cannes Brulée—that the very bottom culpability of this thing rested on the Grandissimes, and specifically on their fogleman Agricola, through his putting the hellish African upon him. Moreover, fever and death, to a degree unknown before, fell upon his slaves. Those to whom life was spared—but to whom strength did not return—wandered about the place like scarecrows, looking for shelter, and made the very air dismal with the reiteration, "*No' ouanga* (we are bewitched), *Bras-Coupé fe moi des grigris* (the voodoo's spells are on me)." The ripple of song was hushed and the flowers fell upon the floor.

"I have heard an English maxim," wrote Colonel De Grapion to his kinsman, "which I would recommend you to put into practice—'Fight the devil with fire.'"

No, he would not recognize devils as beligerents.

But if Rome commissioned exorcists, could not he employ one?

No, he would not! If his hounds could not catch Bras-Coupé, why, let him go. The overseer tried the hounds once more and came home with the best one across his saddle-bow, an arrow run half through its side.

Once the blacks attempted by certain familiar rum-pourings and nocturnal charm-singing to lift the curse; but the moment the master heard the wild monotone of their infernal worship, he stopped it with a word.

Early in February came the spring, and with it some resurrection of hope and courage. It may have been—it certainly was, in part—because young Honoré Grandissime had returned. He was like the sun's warmth wherever he went; and the other Honoré was like his shadow. The fairer one

quickly saw the meaning of these things, hastened to cheer the young don with hopes of a better future, and to effect, if he could, the restoration of Bras-Coupé to his master's favor. But this latter effort was an idle one. He had long sittings with his uncle Agricola to the same end, but they always ended fruitless and often angrily.

His dark half-brother had seen Palmyre and loved her. Honoré would gladly have solved one or two riddles by effecting their honorable union in marriage. The previous ceremony on the Grandissime back piazza need be no impediment; all slave-owners understood those things. Following Honoré's advice, the f. m. c., who had come into possession of his paternal portion, sent to Cannes Brulée a written offer to buy Palmyre at any price that her master might name, stating his intention to free her and make her his wife. Colonel De Grapion could hardly hope to settle Palmyre's fate more satisfactorily, yet he could not forego an opportunity to indulge his pride by following up the threat he had hung over Agricola to kill whosoever should give Palmyre to a black man. He referred the subject and the would-be purchaser to him. It would open up to the old braggart a line of retreat, thought the planter of the Cannes Brulée.

But the idea of retreat had left Citizen Fusilier.

"She is already married," said he to M. Honoré Grandissime, f. m. c. "She is the lawful wife of Bras-Coupé; and what God hath joined together let no man put asunder. You know it, sirrah. You did this for impudence, to make a show of your wealth. You intended it as an insinuation of equality. I overlook the impertinence for the sake of the man whose white blood you carry; but h-mark you, if ever you bring your Parisian airs and self-sufficient face on a level with mine again, h-I will slap it."

The quadron, three nights after, was so indiscreet as to give him the opportunity, and he did it—at that quadron ball.

But Don José, we say, plucked up new spirit.

"Last year's disasters were but fortune's freaks," he said. "See, the crops have failed all about us."

The overseer shook his head.

"*C'est ce maudit cocodri là bas* (It is that accursed alligator, Bras-Coupé, down yonder in the swamp)."

And by and by the master was again smitten with the same belief. He and his

neighbors put in their crops afresh. The spring waned, summer passed, the fevers returned, the year wore round, but no harvest smiled. "Alas!" cried the planters, "we are all poor men!" The worst among the worst were the fields of Bras-Coupé's master—parched and shriveled. "He does not understand planting," said his neighbors; "neither does his overseer. Maybe, too, it is true as he says, that he is voodooed."

One day at high noon the master was taken sick with fever.

The third noon after—the sad wife sitting by the bedside—suddenly, right in the center of the room, with the open door behind him, stood the magnificent, half-nude form of Bras-Coupé. He did not fall down as the mistress's eyes met his, though all his flesh quivered. The master was lying with his eyes closed. The fever had done a fearful three days' work.

"*Mioko-koanga oulé so' femme* (Bras-Coupé wants his wife)."

The master started wildly and stared upon his slave.

"*Bras-Coupé oulé so' femme!*" repeated the black.

"Seize him!" cried the sick man, trying to rise.

But, though several servants had ventured in with frightened faces, none dared molest him. The master turned his entreating eyes upon his wife, but she seemed stunned, and only covered her face with her hands and sat as if paralyzed by a foreknowledge of what was coming.

Bras-Coupé lifted his great, black palm and commenced:

"*Mo cé voudrai que la maison ci là et tout ça qui pas femme' ici s'raient encore maudits!* (May this house and all in it who are not women be accursed)."

The master fell back upon his pillow with a groan of helpless wrath.

The African pointed his finger through the open window.

"May its fields not know the plow nor nourish the cattle that overrun it."

The domestics, who had thus far stood their ground, suddenly rushed from the room like stampeded cattle, and at that moment appeared Palmyre.

"Speak to him," faintly cried the panting invalid.

She went firmly up to her husband and lifted her hand. With an easy motion, but quick as lightning, as a lion sets foot on a dog, he caught her by the arm.

"*Bras-Coupé oulé so' femme,*" he said, and

just then Palmyre would have gone with him to the equator.

"You shall not have her!" gasped the master.

The African seemed to rise in height, and still holding his wife at arm's length, resumed his malediction:

"May weeds cover the ground until the air is full of their odor and the wild beasts of the forest come and lie down under their cover."

With a frantic effort the master lifted himself upon his elbow and extended his clenched fist in speechless defiance; but his brain reeled, his sight went out, and when again he saw, Palmyre and her mistress were bending over him, the overseer stood awkwardly by and Bras-Coupé was gone.

The plantation became an invalid camp. The words of the voodoo found fulfillment on every side. The plow went not out; the herds wandered through broken hedges from field to field and came up with staring bones and shrunken sides; a frenzied mob of weeds and thorns wrestled and throttled each other in a struggle for standing-room—rag-weed, smart-weed, sneeze-weed, bind-weed, iron-weed—until the burning skies of midsummer checked their growth and crowned their unshorn tops with rank and dingy flowers.

"Why, in the name of—St. Francis," asked the priest of the overseer, "didn't the señora use her power over the black scoundrel when he stood and cursed, that day?"

"Why, to tell you the truth, father," said the overseer, in a discreet whisper, "I can only suppose she thought Bras-Coupé had half a right to do it."

"Ah, ah, I see; like her brother Honoré—looks at both sides of a question—a miserable practice; but why couldn't Palmyre use *her* eyes? They would have stopped him."

"Palmyre? Why, Palmyre has become the best *monture* (Plutonian medium) in the parish. Agricola Fusilier himself is afraid of her. Sir, I think sometimes Bras-Coupé is dead and his spirit has gone into Palmyre. She would rather add to his curse than take from it."

"Ah!" said the jovial divine, with a fat smile, "castigation would help her case; the whip is a great sanctifier. I venture it would even make a Christian of the inexpugnable Bras-Coupé."

But Bras-Coupé kept beyond the reach alike of the lash and of the Latin Bible.

By and by came a man with a rumor,

whom the overseer brought to the master's sick-room, to tell that an enterprising Frenchman was attempting to produce a new staple in Louisiana, one that worms would not annihilate. It was that year of history when the despairing planters saw ruin hovering so close over them that they cried to heaven for succor. Providence raised up Etienne de Boré. "And if Etienne is successful," cried the news-bearer, "and gets the juice of the sugar-cane to crystallize, so shall all of us, after him, and shall yet save our lands and homes. Oh, Señor, it will make you strong again to see these fields all cane and the long rows of negroes and negresses cutting it, while they sing their song of those droll African numerals, counting the canes they cut," and the bearer of good tidings sang them for very joy:

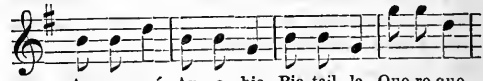

An - o - qué, An - o - bia, Bia - tail - la, Que - re - que,

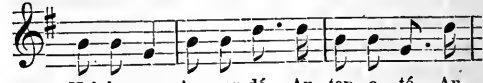

Nal - le - ona, Au - mon - dé, Au - tap - o - té, Au -

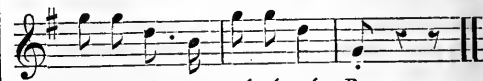

pa - to - té, Au - qué - ré - qué, Bo.

"And Honoré Grandissime is going to introduce it on his lands," said Don José.

"That is true," said Agricola. Fusilier, coming in. Honoré, the indefatigable peace-maker, had brought his uncle and his brother-in-law for the moment not only to speaking but to friendly terms.

The señor smiled.

"I have some good tidings, too," he said; "my beloved lady has born me a son."

"Another scion of the house of Grand—I mean Martinez!" exclaimed Agricola. "And now, Don José, let me say that I have an item of rare intelligence!"

The don lifted his feeble head and opened his inquiring eyes with a sudden, savage light in them.

"No," said Agricola, "he is not exactly taken yet, but they are on his track."

"Who?"

"The police. We may say he is virtually in our grasp."

It was on a Sabbath afternoon that, a band of Choctaws having just played a game of racquette behind the city and a similar game being about to end between

the white champions of two rival faubourgs, the beating of tom-toms, rattling of mules' jaw-bones and sounding of wooden horns drew the populace across the fields to a spot whose present name of Congo Square still preserves a reminder of its old barbaric pastimes. On a grassy plain under the ramparts, the performers of these hideous discords sat upon the ground facing each other, and in their midst the dancers danced. They gyrated in couples, a few at a time, throwing their bodies into the most startling attitudes and the wildest contortions, while the whole company of black lookers-on, incited by the tones of the weird music and the violent posturing of the dancers, swayed and writhed in passionate sympathy, beating their breasts, palms and thighs in time with the bones and drums, and at frequent intervals lifting, in that wild African unison no more to be described than forgotten, the unutterable songs of the Babouille and Counjaille dances, with their ejaculatory burdens of "*Aie ! Aie ! Voudou Magnan !*" and "*Aie Calinda ! Dancé Calinda !*" The volume of sound rose and fell with the augmentation or diminution of the dancers' extravagances. Now a fresh man, young and supple, bounding into the ring, revived the flagging rattlers, drummers and trumpeters; now a wearied dancer, finding his strength going, gathered all his force at the cry of "*Dancé zisqu'a mort !*" rallied to a grand finale and with one magnificent antic, fell, foaming at the mouth.

The amusement had reached its height. Many participants had been lugged out by the neck to avoid their being danced on, and the enthusiasm of the crowd had risen to a frenzy, when there bounded into the ring the blackest of black men, an athlete of superb figure, in breeches of "*Indienne*"—the stuff used for slave women's best dresses—jingling with bells, his feet in moccasins, his tight, crisp hair decked out with feathers, a necklace of alligators' teeth rattling on his breast and a living serpent twined about his neck.

It chanced that but one couple was dancing. Whether they had been sent there to dance by advice of Agricola is not certain. Snatching a tambourine from a by-stander as he entered, the stranger thrust the male dancer aside, faced the woman and began a series of saturnalian antics, compared with which, all that had gone before was tame and sluggish; and as he finally leaped, with tinkling heels, clean over his bewildered partner's head, the multitude howled with rapture.

Ill-starred Bras-Coupé! He was in that extra-hazardous and irresponsible condition of mind and body known in the undignified present as "drunk again."

By the strangest fortune, if not, as we have just hinted, by some design, the man whom he had once deposited in the willow bushes, and the woman Clemence, were the very two dancers, and no other, whom he had interrupted. The man first stupidly regarded, next admiringly gazed upon, and then distinctly recognized, his whilom driver. Five minutes later the Spanish police were putting their heads together to devise a quick and permanent capture; and in the midst of the sixth minute, as the wonderful fellow was rising in a yet more astounding leap than his last, a lasso fell about his neck and brought him, crashing like a burnt tree, face upward upon the turf.

"The runaway slave," said the old French code, continued in force by the Spaniards, "the runaway slave who shall continue to be so for one month from the day of his being denounced to the officers of justice, shall have his ears cut off and shall be branded with the flower de luce on the shoulder; and on a second offense of the same nature, persisted in during one month from the day of his being denounced, he shall be hamstrung, and be marked with the flower de luce on the other shoulder. On the third offense he shall die." Bras-Coupé had run away only twice. "But," said Agricola, "these 'bossals' must be taught their place. Besides, there is Article 27 of the same code: 'The slave who, having struck his master, shall have produced a bruise, shall suffer capital punishment'—a very necessary law!" He concluded with a scowl upon Palmyre, who shot back a glance which he never forgot.

The Spaniard showed himself very merciful—for a Spaniard; he spared the captive's life. He might have been more merciful still; but Honoré Grandissime said some indignant things in the African's favor, and as much to teach the Grandissimes a lesson as to punish the runaway, he would have repented his clemency, as he repented the momentary truce with Agricola, but for the tearful pleading of the señora and the hot, dry eyes of her maid. Because of these he overlooked the offense against his person and estate, and delivered Bras-Coupé to the law to suffer only the penalties of the crime he had committed against society by attempting to be a free man.

We repeat it for the credit of Palmyre,

that she pleaded for Bras-Coupé. But what it cost her to make that intercession, knowing that his death would leave her free and that if he lived she must be his wife, let us not attempt to say.

In the midst of the ancient town, in a part which is now crumbling away, stood the Calabozo, with its humid vaults, grated cells, iron cages, and its whips; and there, soon enough, they strapped Bras-Coupé face downward and laid on the lash. And yet not a sound came from the mutilated but unconquered African to annoy the ear of the sleeping city.

("And you suffered this thing to take place?" asked Joseph Frowenfeld of Honoré Grandissime.

"My-de-seh!" exclaimed the Creole, "they lied to me—said they would not harm him!")

He was brought at sunrise to the plantation. The air was sweet with the smell of the weed-grown fields. The long-horned oxen that drew him and the naked boy that drove the team stopped before his cabin.

"You cannot put that creature in there," said the thoughtful overseer. "He would suffocate under a roof—he has been too long out-of-doors for that. Put him on my cottage porch." There, at last, Palmyre burst into tears and sank down, while before her on a soft bed of dry grass, rested the helpless form of the captive giant, a cloth thrown over his galled back, his ears shorn from his head, and the tendons behind his knees severed. His eyes were dry, but there was in them that unspeakable despair that fills the eye of the charger when, fallen in battle, he gazes with sidewise-bended neck upon the ruin wrought upon him. His eye turned sometimes slowly to his wife. He need not demand her now—she was always by him.

There was much talk over him—much idle talk; no power or circumstance has ever been found that will keep a Creole from talking. He merely lay still under it with a fixed frown; but once some incautious tongue dropped the name of Agricola. The black man's eyes came so quickly round to Palmyre that she thought he would speak; but no; his words were all in his eyes. She answered their gleam with a fierce affirmative glance; whereupon he slowly bent his head and spat upon the floor.

There was yet one more trial of his wild nature. The mandate came from his master's sick-bed that he must lift the curse.

Bras-Coupé merely smiled. God keep thy enemy from such a smile!

The overseer, with a policy less Spanish than his master's, endeavored to use persuasion. But the fallen prince would not so much as turn one glance from his parted hamstrings. Palmyre was then besought to intercede. She made one poor attempt, but her husband was nearer doing her an unkindness than ever he had been before; he made a slow sign for silence—with his fist; and every mouth was stopped.

At midnight following, there came, on the breeze that blew from the mansion, a sound of running here and there, of wailing and sobbing—another Bridegroom was coming, and the Spaniard, with much such a lamp in hand as most of us shall be found with, neither burning brightly nor wholly gone out, went forth to meet Him.

"Bras-Coupé," said Palmyre, next evening, speaking low in his mangled ear, "the master is dead; he is just buried. As he was dying, Bras-Coupé, he asked that you would forgive him."

The maimed man looked steadfastly at his wife. He had not spoken since the lash struck him, and he spoke not now; but in those large, clear eyes, where his remaining strength seemed to have taken refuge as in a citadel, the old fierceness flared up for a moment, and then, like an expiring beacon, went out.

"Is your mistress well enough by this time to venture here?" whispered the overseer to Palmyre. "Let her come. Tell her not to fear, but to bring the babe—in her own arms, tell her—quickly!"

The lady came, her infant boy in her arms, knelt down beside the bed of sweet grass and set the child within the hollow of the African's arm. Bras-Coupé turned his gaze upon it; it smiled, its mother's smile, and put its hand upon the runaway's face, and the first tears of Bras-Coupé's life, the dying testimony of his humanity, gushed from his eyes and rolled down his cheek upon the infant's hand. He laid his own tenderly upon the babe's forehead, then, removing it, waved it abroad, inaudibly moved his lips, dropped his arm and closed his eyes. The curse was lifted.

"*Le paw' dgiab'!*" said the overseer, wiping his eyes and looking fieldward. "Palmyre, you must get the priest."

The priest came, in the identical gown in which he had appeared the night of the two weddings. To the good father's many tender questions Bras-Coupé turned a failing eye that gave no answers; until, at length:

"Do you know where you are going?" asked the holy man.

"Yes," answered his eyes, brightening.

"Where?"

He did not reply; he was lost in contemplation, and seemed looking far away.

So the question was repeated.

"Do you know where you are going?"

And again the answer of the eyes. He knew.

"Where?"

The overseer at the edge of the porch, the widow with her babe, and Palmyre and the priest bending over the dying bed, turned an eager ear to catch the answer.

"To—" the voice failed a moment; the departing hero essayed again; again it failed; he tried once more, lifted his hand, and with an ecstatic, upward smile, whispered, "To—Africa"—and was gone.

(To be continued.)

THE VILLAGE CHURCH.

WITHIN the village church again,
To which my boyish steps were led,
With keenest pleasure, keenest pain,
I sat, communing with the dead.

Too sad had seemed the busy street,
Too strange the once familiar roof;
Nor was there any voice to greet
The wanderer with its sweet reproof.

Fain would my feet have turned and fled;
But with a sudden sense of shame
To leave the dead unvisited,
On to the churchyard gate I came.

The autumn rain was falling fast;
The leaves were strewn above the graves;
And in the pauses of the blast
There came the sound of moaning waves.

Their voice seemed crying unto me,
"Why is it thou couldst not forget?
Why hast thou come o'er land and sea,
To find no guerdon but regret?"

Then from the church the songs of praise
Broke on my mood of doubt and sin;
So strong the spell of other days,
I could not choose but enter in.

And in the holy house I found
My spirit's early home once more;
And vexing chains that years had bound
Dropped from me at the open door.

What though in the familiar place
I sat a stranger and a guest?
I turned from every unknown face
To those my heart made manifest.

I scarcely heard the preacher's voice,
Such thronging memories o'er me swept;
I only know I did rejoice,
I only know I grieved and wept.

For I was praying as of old,
And clasped a mother's gentle hand;
And felt the ties of love enfold
A long-divided household band.

From the old pulpit, high and quaint,
I heard with Sinai's thunders blend,
The raptures of a suffering saint,
The pity of a human friend.

That gracious voice, now touched with pain,
Now thrilling with celestial cheer,
Joined long ago the angels' strain,
But left its hopeful echoes here.

And now the joyous anthem rang
The same unchanging notes of praise;
But other lips they were that sang
With me in unforgotten days.

Those lips are dumb; and underneath
The waves of Indian seas she lies
Who sang victorious over death,
And in my heart who never dies.

This was her home, and here her vows
Of trembling faith to God were paid;
And now within His heavenly house,
She serves Him, pure and unafraid.

The short November day grew dim,—
No ray of sunlight cheered its close;
And as we sang our parting hymn,
Loud, and more loud the tempest rose.

Yet ere I passed the church-yard gate,
The answer to my prayer was given;
For strength to suffer and to wait
Was the best boon I asked of heaven.

THE GROWTH OF WOOD-CUT PRINTING. I.

EARLY METHODS ON THE HAND-PRESS. 1450—1850.



ENGRAVED INITIAL LETTER AND MOVABLE TYPES OF THE MENTZ PSALTER.

To STAMP paper upon inked types seems the simplest of mechanical operations. Done in a primitive way, it is simple. By turning the crank of his toy printing-press, the twelve-year-old amateur can produce a print which he and admiring friends say is good enough for anybody. They are sure that there is no mystery and but little science in press-work. It is as easy as Hamlet's lesson in flute-playing: "Tis as easy as lying: govern these ventages with your fingers and thumb, give it breath with your mouth, and it will discourse most eloquent music." Nearly every meddler with a press thinks that he understands the theory of wood-cut press-work. For that, too, is so simple: you have but to put more ink on this black portion of the cut, and less on that lighter portion; more impression on this dark shadow and less on that light sky; and the thing is done. No truism can be plainer; but it does not help the amateur any more than another truism—that the de-

sign from which the wood-cut will be made is, mechanically, nothing more than india-ink dabbed over the block. Knowing where ink should be put does not qualify one where to put it—neither on paper nor on the wood. The amateur in wood-cut printing will soon find that he cannot put ink and impression where he purposes.

That it is difficult to print wood-cuts is fairly enough shown by the general dissatisfaction of engravers with the printer's handling of their blocks. Not one cut in a dozen is printed as well as the engraver expected it would be, not even when it has been printed by an expert. Printers are equally dissatisfied. As a rule, they do not covet the work; most of them say it is vexatious and unprofitable; some say they never want to see a wood-cut in their press-rooms.

This dislike is of long standing. Gutenberg, inventor of typography, during a period when the manuscript books made for the rich were full of illustrations, and the block-books of the poor were full of printed and painted pictures, never, so far as we know, made any use of engravings on wood. His pupil, Peter Schœffer, after an experiment in partly printing, partly painting, the engraved initials of the Psalter,—initials apparently cut on metal,—gave up the process and did the rest of his work on types. Not one of the many great master printers of the sixteenth century showed any favor for wood-cuts. The reputation or profit which may have been gained by the publishers of large engravings like Burgmair's "Triumph of Maximilian," or Dürer's "Apocalypse," never tempted famous typographers into rivalry. All of them, from Aldus Manutius to Daniel Elzevir, slighted engraving on wood. The few book printers who did try preferred cuts of small size. Indeed, at the beginning of the seventeenth century, publishers and the reading public had reached the conclusion that engraving on wood was a low branch of art, and that illustrations of merit could be had only through the copper-plate process.

The preference of artists for copper-plate hastened, but did not entirely cause, this degradation of an art which was older than typography. Wood-cuts were not neglected because publishers were stupid, for they knew quite as well as publishers know now,

the superior utility of illustrations that may be printed with the types of the text. Nor did wood-cuts go out of fashion for lack of able artists or engravers. But one plausible explanation may be hazarded: the wood-cuts that readers and publishers wanted could not be properly printed with types. The arts of designing and engraving had outgrown the art of printing. Why?

The wood-cuts of the block-books which preceded and introduced typography were mainly in bold outline—not pictures, only the skeletons of pictures, guides to the colorists by hand or stencil, who filled the boundary lines with flat color and completed the work by painting. For prints like these, engraved tints of gray were unnecessary. Light and shade, nearness and distance, were fairly enough suggested by

on the stringy fibers of the flat planks of pear or apple wood then in regular use. Nor could these tints and lines have been printed, if they had been cut. Fine lines, cut parallel with the fiber, would have frayed or flattened out after a few impressions had been taken.

The outline style, maintained for nearly fifty years after typography had been invented, was preferred because it was easy to print. It did not require so much ink nor so much impression as the closely fitting, black-faced Gothic types then in fashion. But these little merits did not make the wood-cut unobjectionable to the typographer. The flat block was more liable than ever to crack or warp when wedged in with types that had to be washed or cleaned, and this warping or cracking was



A SECTION FROM ONE OF BURGMAIR'S PRINTS OF "THE TRIUMPH OF MAXIMILIAN."
Reduced fac-simile. From original in collection of Mr. Russell Sturgis.

contrasts of painted colors. These wood-cuts were easily made, for the artist clearly laid down every line on the block, and were easily printed, for the bold outlines called for little care in inking and no nicety of impression. Coarseness and simplicity were not altogether of choice. The outline style was the only style suited to the wood and to the press. Delicate sky and cloud tints and close shading lines could not have been cut

a hindrance to the pressman. To evade this difficulty, some printers printed the types and cuts that appeared on the same sheet by separate impressions. The four editions of the "Speculum Salutis," erroneously attributed to Coster of Haarlem, but probably printed by an unknown typographer after 1463, give plain evidence of this double labor. A book of Colard Mansion, once the associate of Caxton, also



THE APOCALYPSE, DRAWN BY ALBERT DÜRER.

Reduced fac-simile. From original in collection of Mr. Russell Sturgis.

shows cuts printed separately. That it was done by other printers so neatly that it cannot now be detected is more than probable.

But even when neatly done, the wood-cuts furnished by most printers at the beginning of the sixteenth century were not satisfac-

Jonas ghinc vte waluisch na ti daghe
 iernacht Des sonē dages des inder naches
 die helle ghebroke ofte verdorue is hi ton si
 nē hachem ghegaē Christus heeft sin verrise

TYPES OF THE "SPECULUM SALUTIS."

tory. Readers wanted something more than skeleton illustrations. Great changes had then been made in many features of book-making; octavos had taken the place of quartos and folios; the light-faced Roman and Italic letters were supplanting the somber Gothic; the stencil painting of wood-cuts and initials was going out of fashion. Printers were asked to furnish cheaper books—books that should be perfect when published, not requiring the added labor of illumination—books with engraved initials and more attractive illustrations.

Earnest efforts seem to have been then made for the improvement of engraving on wood. Holbein and Dürer furnished designs which were faithfully reproduced by engravers as zealous in the work as the artists themselves. New textures and styles were introduced; the cross-hatchings of copper-plate and the shadings of brush or pencil were imitated. Attempts were made to print illustrations in many tints of the same color from different blocks. Unsuccessful in this experiment, engravers tried to put color in their blocks by finer engraving and a bolder use of full black. The devotional books of "Hours," printed at Paris by Verard, Vostre, Kerver, and others, with quaint designs in white, on solid or stippled black background borderings, inclosing outline or silvery-gray prints of great delicacy, show a worthy attempt to imitate the beauties of illuminated missals, as well as an artistic

appreciation of the true field of engraving in relief in its ability to show strong contrasts of black and white. It is by no means certain that all these illustrations were



OLD ENGRAVING IN OUTLINE.
 A page from a block-book of the fifteenth century, known as the "Eight Rogueries." Reduced fac-simile.

cut in wood. They show a sharpness of line, a freedom from gaps or cracks, and an absence of the crookedness made by warping, that suggest the use of brass or type-



A poi che la Gallia fu acquetata: & Cesare uenne in Italia a far noue compagnie: se in/ tefe della morte di Clodio: della deliberatiō del Senato: & si come tutti li giouani della Italia haueano congiurato: si che Cesare de libero scriuer genti per tutta la prouincia. puēne anchora questa nouella subito nel/

EARLY ROMAN TYPES OF LIGHT FACE.
 From a book printed at Venice, 1517.

metal. This probability is strengthened by the squareness and close fitting of detached pieces, and the occasional appearance of dents or bruises of a peculiar character entirely unlike those produced by mishaps on wood.

These improvements in engraving called for improved skill in printing, to which the printer could not respond. The sharp outline cut and the thin, silvery-gray cut were too fine to be printed by the side of types. The light lines were too often choked with ink or crushed by pressure; the cribbled black backgrounds could rarely ever be fairly inked without an over-inking of the types, and they demanded more impression than the pressman could give. The press of the sixteenth century was too weak for the work. Jodocus Badius, an eminent printer of Paris, has put in the title-page of one of his books an engraving on wood which shows us the construction of the printing-press of 1520. From this and other sources we learn that the frame-work of this press was made of heavy beams of wood; the great screw was of wood; the platen, or pressing surface, was of wood; the bed, or surface on which types and wood-cuts were fixed to receive impression, was sometimes of stone, but oftener of wood. No doubt the wood selected was hard, well seasoned, neatly jointed and fitted, but the strain of continued pressure, working from the inside outward, as well as the tendency of the wood to shrink, warp and crack, soon made the best constructed press shakky. It was with reason that Moxon, who wrote in 1683, denounced the presses of his predecessors as "make-shift, slovenly contrivances."

The press was large and strongly built, but it took all of a man's strength to work it. In the cut before us, the pressman, with fairly-braced feet, is pulling at the bar with both arms. The screw has a large thread which presses directly on the platen, relieved a little by the collar and rods, but not steadied in its descent by any counterpoise or spring. Nor is there any combination of levers to ease the pull at the bar,

which was a "dead pull," harder at the end than at the beginning. Much of the force exerted was lost. The stout braces over the cross-beam at the top of the press show us that this beam would spring and lose the pressure if it were not strongly braced. The surface covered by the downward pressure of the platen was very small—but little larger than that of two pages of SCRIBNER'S MAGAZINE. Presses were made to suit the sizes of paper in common use, and these



THE HAND-PRESS OF THE SIXTEENTH CENTURY.

sizes ranged from 14 by 20 to 16 by 21 inches. It was commercially impracticable to make paper of larger size by the old methods of paper-making. Although the early papers were about only one-fourth the dimensions of the papers now used in book printing, they were too large to be printed on one side by one impression. Four distinct impressions had to be given to the printing on both sides of a sheet 16 by 21 inches. The method was as follows. The pressman pulled down the bar when one-half of a

white sheet was under the platen; then, releasing the pressure, he drew the other half under the platen and pulled again. To print the reverse side, the operation just described had to be repeated. It was a tedious method, but the only one known to printers. The resistance offered by a printing surface of about ten by fourteen inches was all the press would bear. A larger surface would overtax the pressman and break the press. The printer had to be content with the printing of one folio page, or of two octavo pages, at one impression. It was important, too, that the printing surface



Inking. Work at Press. Type-casting.

OLD ENGLISH PRINTING OFFICE.

From an undated book, about 1560.

should not contain types or cuts of unusual blackness or resistance. A wood-cut with solid black background, of the full size of the platen, little as that size was, could not have been properly printed. The press was not strong enough. There was, then, a good mechanical reason why engravers and printers preferred small cuts and outline cuts, and disliked those that had black backgrounds or dark shadows.

The difficulty of inking the cuts by the methods then in use should also be considered. The above illustration shows that two men were needed to work the press—one to pull or print, and one to ink. The pressman who does the inking holds in each hand an inking-ball—a stuffed cushion of leather on which glutinous printing-ink was evenly distributed by rocking the curved sides against each other in every direction. This done, with these balls he beat the face of the types or cuts on the press, until they were properly covered with a thin film of ink. When the cuts were in coarse outline, and the surrounding types were of black Gothic face, the task of inking was light, for types and cuts required about the same amount of ink. When the types were of a light Roman or Italic face, and the cuts were

black, or blackish gray in tone, it was then necessary to put more ink on the cuts and less on the types. This was not easy. It called for a discriminating eye; on one part of the form a dainty touch; on another, vigorous and persistent beating. For a very fine cut, the inking of the form took almost as much time as the inking and wiping of a copper-plate.

There was another difficulty. Much of the paper made in the sixteenth century was unsuitable for wood-cuts. By far the larger portion was made of linen stock, hard and rough as to surface; laid, or showing the marks of the wires upon which the pulp had been crushed; of ragged edges, unsized, and very sensitive to dampness; uneven in thickness, usually thin in the center and thick at the edges. The method of making wove paper, or paper entirely free from ridges, had not then been discovered. These ridges did not seriously interfere with the getting of fair impressions from types; but they must have been a great annoyance to the pressman who tried to get a sharp impression from the more delicate lines of a fine wood-cut. If he adjusted his impression so that the engraved lines just touched the tops of the ridges, then the paper in the hollows would not meet the line; the print would show broken or ragged lines. If he forced impression, making the engraved lines touch every part of the paper, then these lines would be jammed in the paper, and would consequently appear thick and muddy in the print. To avoid this fault, some of the Italian and French printers of this period had paper made for them on closer fitting wires of great fineness—so close that the laid marks can be seen only when the leaf is held against the light. This improvement made the true Venetian paper “light, slender and subtil,” as Fuller describes it; but at its best it could not take as clean an impression as modern wove and calendered paper. Vellum was sometimes used by the eminent printers of Paris, especially for choice copies of the books of “Hours.” When the vellum was in proper condition, it would receive impression admirably; but it was then, as it is now, the most treacherous of printing surfaces. Of two skins that looked alike and seemed equal in every particular, one would take a fine impression, while the other, imperfectly cleansed of lime or grease, would reject the ink in spots, making a cloudy, grimy print.

The paper selected was, in most cases, too rough and hard to be forcibly impressed



ENGRAVING ON WOOD.

From a Print by Jost Amman, 1564.

against the delicate lines of fine wood-cuts. It was the usage everywhere to soften the paper by a careful dampening. When the paper was sized it was not weakened by this dampening, which really lightened the labor of the pressman. But unsized paper was only about half the price of the sized, and the inducement to use it was great. The unsized paper was dampened with difficulty; it greedily sucked up water, and, when fully wet, became flabby and unmanageable. Under the searching pressure of the woolen blanket, which was always put between the paper to be printed and the pressing surface, this flabby paper was forced around the finer lines of the cut, making them much thicker than was intended.

In spite of these imperfections good press-work was done. Books were printed at Paris, Lyons and Venice containing wood-cuts which show that they had been made ready by pressmen expert in overlaying (or the art of varying the pressure upon the light and dark portions of cuts, by means of properly affixed bits of paper, so that each portion gets what pressure it needs and no more) and in other refinements of press-work erroneously rated as new inventions. But this fair rendering of wood-cuts was exceptional. It was a fight against odds, which could not be long kept up. The press was too weak for vig-

orous blacks and the paper too rough for fine lines. To give the full measure of blackness to one part of the cut and proper delicacy to another, could be done only by a pressman who had unusual skill and patience, and, above all, an intelligent sympathy with the purpose of the artist. Pressmen of this character were never abundant. It is not to be wondered at that early master printers tired of wood-cuts. The chances of failure or loss were many; the reputation or profit to be gained by an occasional success was slight.

The difficulties encountered by the printers must have been understood by the engravers, for we see—at least among the engravers of Paris—that they altered their style to suit the weakness of the press. Strong contrasts of black and white like those of the borders of the books of "Hours" and the trade-marks of some publishers, were rarely attempted after 1550. In giving up the style of white lines on a black background, engravers gave up the style which was easiest to them—the style which many art critics say is the most natural and the most effective. Engravers did not give it up willingly. They tried to conceal the damages done to their cuts from badly distributed ink, and the dinginess made through too weak impression, by dotting the black



DEVICE OF THIELMAN KERVER.



DEVICE OF CHRISTOPHER PLANTIN, "KING OF PRINTERS."

From a book of 1588.

backgrounds with little pin-holes of white after the *manière criblée* of the copper-plate engravers. The attempt was not successful; the dotted groundwork soon went out of fashion. Engravers everywhere fell back on the older style of cutting, in which the design was shown by outlines, by coarse shadings and monotonous tints. This made the cut easy for the printer. The cut that had few exposed light lines, and no full blacks, and few blackish grays, was as easily inked and printed as types. But this full surrender to the weakness of the early press of that strong contrast of light and shade which is the greatest merit of engraving on wood, nearly ruined the art. The print in flat

and monotonous gray made so ineffective an illustration that designers of good reputation refused to draw for engraving on wood. Compared with a print from copper, the print from wood was a travesty of the artist's design. It is difficult to imagine meaner illustrations than the spiritless, grimy, gray wood-cuts of the books of the seventeenth and eighteenth centuries. The device of Plantin is a fair illustration of this debased style. This meanly engraved cut was the device of the "first printer to the king and the king of printers," as is tersely stated in his epitaph. Truly a sorry performance for a printing-house that made types in silver matrices,—a house that

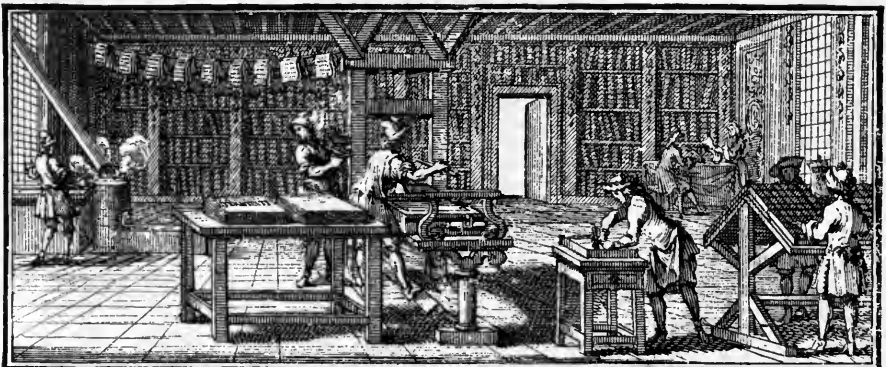

Type Founding.

Inking Balls.

Work at Press.

Correcting Errors.

Proof Reading.

Composing.

OLD FRENCH PRINTING OFFICE.

Fac-simile of a copper-plate head-band in La Caille's "Histoire de l'Imprimerie," Paris, 1689. (A cut too fine to be engraved on wood at the close of the seventeenth century.)

printed the great "Antwerp Polyglot," and that afterward enlisted the services of the great designers Rubens and Teniers, Van Dyck and Jordaens, and the most famous Flemish engravers on copper. The art had sunk so low that typographic printers refused to use it in their own books, even in instances where its use seemed imperative. Copper-plate fac-similes of early types, as well as copper-plate vignettes, head-bands and tail-pieces are common in books on typography published during the seventeenth and eighteenth centuries.

The honor of restoring the neglected art to its rightful position is conceded without question to Thomas Bewick of Newcastle, England. The wood-cuts of his first important work, Gay's "Fables," 1779, were inferior to those that followed—"Select Fa-

make his own tools and learn from his own blunders. When he became a man he worked for himself more than for others. He planned the books that made him famous, choosing his subjects, making most of his drawings with his own hand, and working on them in his own time and way. In every important matter he struck out his own path. Paying little regard to usage, he made lines, textures and tints to suit his own notions of art or propriety.

All these notions were governed by the lessons he had learned from the mechanical drudgeries of his apprenticeship—that good art is based on good mechanics; that a good print does not depend on good engraving only; that careful attention to every contributing aid, from the selection of the wood to the printing of the block, is of

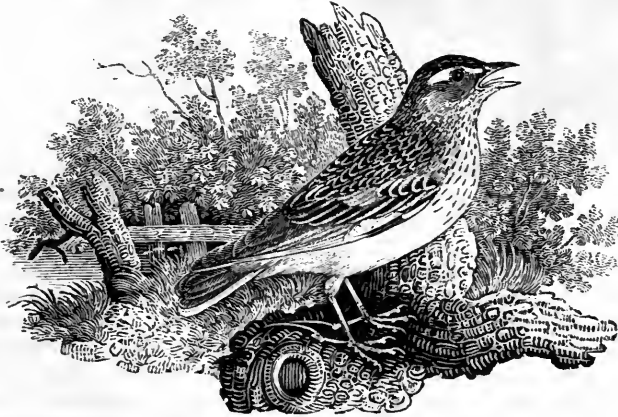

THE WOODLARK.

Fac-simile. From Bewick's "British Birds."

bles" (1784), "Quadrupeds" (1790), and "British Birds" (1797 and 1804)—but they showed the hand of a master, and their merits were recognized by educated artists as well as by the inartistic public for whose benefit they had been designed. Bewick's success was largely due to his hard, narrow education. Apprenticed to the "general engraver" of a small town, he was taught more of mechanics than of art—taught to engrave on copper, to polish and cut door-plates and seals, to ornament gun-locks, brass and silver-ware. He was not taught engraving in relief by a professional engraver on wood, and, consequently, escaped the mortification in later years of having to unlearn the false style of engraving then in fashion. While a boy he took to engraving on wood of his own inclination, having to

importance. Much of this attention to detail was of choice, and some of necessity. Working at a distance from the haunts of artists and skillful craftsmen, he had to do with his own hands what in a larger city he might have had done for him. Doing all his own work, it was thoroughly done. How much he discovered and how much he learned from other engravers during his brief residence in London in 1776 cannot be stated. Some have said that Bewick was the first engraver who cut on the end or upright fiber of the wood, instead of on the flat side of the plank, as had been the custom for three centuries. This is not credible, for the advantages of cutting on columnar fibers had been described in 1766 by Papillon, an eminent French engraver. Others say Bewick was the first to lower the

surface of his blocks on those parts where great grayness or delicacy was desired. This claim cannot be allowed, for traces of lowering the surface are noticeable in many of the wood-cuts of the first Lyons edition of Holbein's "Dance of Death." This valuable improvement did not really originate with Bewick, but with his fellow apprentice, Bulmer, the printer, who afterward became equally famous as the founder of the Shak-

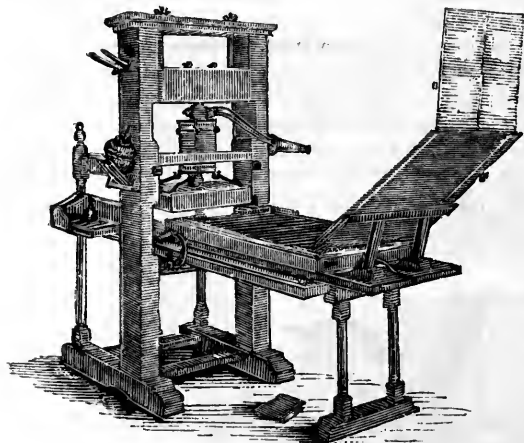

WOOD-FRAME HAND-PRESS OF 1800.

Bewick's cuts were printed on a press like this.

spere press. Equally untenable is the assertion that Bewick was the first who used overlays in printing, for the marks of the unequal pressure made by overlays are to be found in many prints of the sixteenth century. It is possible that Bewick rediscovered these processes, for all of them are simple, and would have been suggested to an engraver who studied the theory of his art, and liked the work for the work's sake. It may be admitted, however, that Bewick was the first engraver of eminence who used these processes thoroughly and persistently, making a success which compelled their adoption by others.

Bewick's good sense is shown in the simplicity of his style. When he began to cut, engravers on wood were imitating as well as they could the mannerisms of copper-plate. They rated that the best wood-cut which had the finest cutting and cross-hatching, and the least of plain black and white. Bewick had the wit to see that the true field of engraving of wood was not in monotonous tints, but in clearness of form and decided contrasts of light and shade. He always made use of the simplest methods, never putting in two lines where one

would serve, never attempting novelties in lines and textures for the purpose of showing his skill. He fairly shows his subject, but never puts himself and his methods offensively before it.

All of Bewick's cuts were printed in the old two-pull wooden hand-press, by means of leather inking-balls. That he had some trouble in getting them properly printed in his town, appears from Hodgson, the printer of his works, sending to London for an expert pressman. He knew the weakness of the press, and made cuts of small size only. He knew the tendency of the press to flatten or dull the contrasts he desired, and he labored to prevent this mischief. The care he took in lowering the surface of blocks where delicacy was needed seems almost incredible. The good printing of his cuts was due more to this careful provision than to the skill of the pressman. He never shuffled off on the printer any work that he could do himself. In this point he deviated widely from established usage. Papillon tells us that the engravers of his time concealed the defects of their cutting by an artful method of taking proofs—a method unhappily not yet obsolete—which caused the inexpert purchaser of the cut to believe that a line delicately gray in the proof, but really harsh and black in the wood, could be made to appear thin and gray in the print. From this deception Bewick was entirely free. He never required the pressman to smooth over work he had neglected. He did all the work his subject required—did it manfully and resolutely, regardless of time or trouble.

Bewick's success compelled a respect for engraving on wood which it had never received in England. Wood-cuts came in fashion. Bewick's pupils and imitators found abundant employment. Some were his equals in mechanical skill, but not one of them seems to have had his knowledge of the limitations as well as of the capabilities of the revived art. Most of them fell away from his simple style, and tried to imitate copper-plate. Many of them tried to rival the size as well as the style of large line engravings. It is painful to look over many of the large wood-cuts attempted in England during the first quarter of this century—for although the skill shown in these cuts is often of the highest order, the labor given to them was practically labor

lost. Not one in a dozen was ever properly printed. For the press in most general use at the beginning of this century was, in all important features, the press used by Badius in 1520. Blaeu, an assistant to the astronomer, Tycho Brahe, in 1620 had made some improvements in the minor mechanisms, but he left the press as he found it, no stronger than it was before—a press of wood barely equal to the task of printing by one

couragement to those wood-cutters who were trying to imitate copper-plate engravers in delicacy of line, and size and blackness of print.

Here it seems necessary to allude more fully to a common error—to the notion that a fine wood-cut, by reason of the fineness of its lines and the frailty of its wood, can be neatly printed only by a corresponding delicacy and implied weakness of impression.

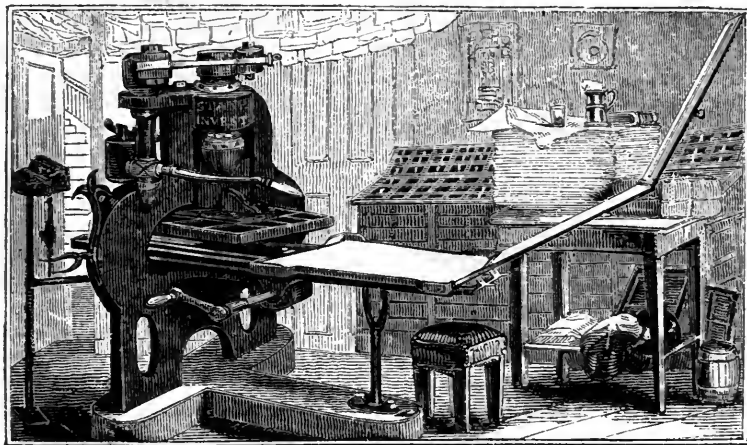

THE STANHOPE PRESS.

impression a type surface of 150 square inches, and not at all strong enough to print properly a black wood-cut of even smaller dimensions. The popularizing of engraving on wood, of which engravers and publishers were dreaming, was even then waiting for improvements in the press.

The first real improvement in construction came from France. Ambroise Firmin Didot, of Paris, had made for him, during the last ten years of the last century, a press with a platen, or pressing surface, of iron, large enough to print the full side of a sheet by one impression. It was, perhaps, the fame of this iron platen that stimulated Earl Stanhope, an eccentric English inventor, to attempt a press all of iron. In 1798 the Stanhope iron press was presented to the trade—presented in the fullest sense, for the inventor did not patent one of its many valuable features. If this press had not been so soon superseded by the steam printing machine, the value of the gift would be more gratefully remembered. For it was the first press entirely of iron, and the only press, at the beginning of this century, which promised strength enough to warrant the engraving of large and black wood-cuts. It gave en-

The facts really are that an ordinary wood-cut calls for twice as much impression as a similar surface of types; while a wood-cut with black background, or very full of blackish grays, may need ten times as much. An inequality of impression must be made, not only on cuts of different degrees of blackness, but in the different shades of the same cut. For the blacker shades there must be strong, for the lighter tints very little, impression. To do its work properly, the press must have great strength, and with this strength provisions for variations in adjustment which will enable the pressman to put as much or as little pressure as he pleases on any part of a cut. There must be a hand of iron under the glove of velvet.

The Stanhope press was strong, but it was soon overtaxed. Soon after it had been fairly introduced, William Harvey, an eminent engraver of London, sent to this press an engraved block of the "Assassination of Dentatus," a block eleven and one-half by fifteen inches, cut in close imitation of the then admired copper-plate style—probably the largest, certainly the most labored, block that had then been cut in England. Harvey's dismay was great when he learned that

this block, over which he had worked for three years, was too large and too black to be fairly printed on this strong press of iron. Fortunately for the engraver, the printer of the block was induced to try it on the Columbian press, invented a short time before by Clymer, of Philadelphia. The Columbian was a huge iron press with strong leverage, and with the added advantage of a heavy counterpoise; but at the outset it was not more successful than the Stanhope. By lengthening the lever of the new press and getting two men to pull together on the bar, some satisfactory prints were taken. The success was brief. The press proved too strong for the block, which broke under the pressure before the proposed edition had been completed, putting an end, for a time at least, to this invasion in the field of line engraving.

This accident, coupled with the knowledge that wood-cuts of small size often suffered serious damage by wear on press, induced many printers to avail themselves of the advantages promised by the new art of stereotype, which, after much experimentation, had been made practically useful by Earl Stanhope. It was soon found that however useful stereotype might be for types it was not a good process for wood-cuts. Engravers were not satisfied with the want of faithfulness in casts taken from plaster. Printers were not satisfied with the unavoidable softness of stereotype metal—with the quick wearing down of a stereotyped cut, its thickening of lines and confusion of tints under the kindest usage. It was agreed by all parties that, as a rule, stereotype was more of a hindrance than a help in wood-cut press-work. Printers fell back in the old rut, and continued to print wood-cuts from the wood.

They did this unwillingly, for the newly invented art of lithography was encroaching on their own field. Instead of competing successfully with line engravers in the production of large prints, type-printers had to give up to the lithographer the full-page illustrations of many books.

Here is a paradox. Although the wood-cut printers failed for want of a stronger press, the presses of their rivals were not as strongly built as the Stanhope and Columbian. But the lithographers and copper-plate printers had a superior method of doing press-work. Applying impression by means of a scraper or a cylinder gradually passed over the surface of the stone or the copper, they could give strong impression

with comparatively little exertion and little risk of breakage. They had a decided advantage over the wood-cut printer, who, by one sudden blow through a quick pull of the bar, diffused a greater force over a surface a hundred times, sometimes a thousand times, greater than the surface impressed at one instant on stone or copper. The power of the hand-press was weakened by its diffusion over too large a surface.

The strong press which the wood-cut printer needed came in an unexpected shape. On the 28th of November, 1814, the "Times" of London was printed for the first time upon a machine—a rotating cylinder which gradually but quickly impressed the types laid upon a reciprocating bed-plate. This new machine did the impressing part of its work by original mechanism, but in the same way that impression was given by the presses of the plate and stone printers—printing little by little at a time. It was imperfect, but, from the beginning it gave assurance of strength and speed; it foretold a revolution in typography. The new machine was not welcomed by book printers, who, with one accord, denounced it. It was bulky, complex, expensive, destructive to type, deficient in provision for inking. The last charge was too true, for the leather rollers which had to be used instead of leather balls did not fairly ink the types. On this apparently minor feature the fate of the invention depended. Cloth, silk and felt rollers were tried and rejected, and from the failure of all kinds of rollers, the failure of the machine was predicted. Many printers held stoutly to the notion that wood-cuts could be properly inked only by the inking-ball in the hands of an expert pressman, and that mechanical or automatic inking must be a failure. The reasoning was plausible. The inking-ball permitted the pressman to put as much or as little ink as he pleased on any part of the cut or form, while the inking-roller in the machine compelled the pressman to accept an equal distribution and an equal supply of ink over every part of the form, even in forms that called for unequal supply. The builders of the machine were slow to admit the inferiority of the roller, for the use of inking-balls on machines was out of the question. Speed could be had only through the use of the swiftly rotating roller.

At this critical time, somewhere about 1815, while the capability of the machine for doing good book printing was still un-



A SECTION OF HARVEY'S ENGRAVING OF THE "ASSASSINATION OF DENTATUS."

Reduced fac-simile. From the original print in the collection of Mr. N. Orr.

proved, the attention of a printer was accidentally called to the merits of the dabber composition of the Staffordshire potteries. This composition, a mixture of glue and molasses, was smooth, firm, elastic, accepting and imparting oily ink much more freely than the leather inking-ball. It was soon

shown that this was the proper material for the machine roller. More—it was proved beyond cavil, that a fairly managed composition roller on a machine that printed ordinary book-work would ink the types more smoothly than could be done by leather balls on the hand-press.

This was a great gain, but much more was needed. To do fine or even fair wood-cut press-work, paper of uniform thickness and of a reasonable smoothness of surface was of importance. These qualities could not be had in hand-made papers at reasonable price. To meet the demand for finer and cheaper papers in larger sheets, Louis Robert and St. Leger Didot of France, aided by the brothers Fourdrinier and Bryan Donkin of England, patented in England, between 1801 and 1810, a machine for making paper in a continuous web. Although this machine originated with Robert, it has been called the Fourdrinier, in honor of the brothers, who spent sixty thousand pounds on it, and became bankrupt, before it was perfected. It did not meet with much favor from book printers. They condemned, not without reason, the early machine-made paper as weak, spongy, badly sized, and every way unfit for fine books. In spite of these grave defects, some publishers encouraged the inventors to renewed exertion. The publishers of periodicals were especially interested, for they knew that the daily newspaper and monthly magazine of 100,000 copies, and New Testaments, to be read by millions and sold for a sixpence, the possibility of which had even then been foreshadowed, could not be without machines.

For many years the book printers of England and America opposed machines and machinery. It was the almost unanimous opinion of the printing trade, even as late as 1840, that really fine wood-cut press-work must be done on the hand-press and on hand-made paper. This was an unfortunate conclusion, for it confirmed engravers on wood in fashions of making cuts that could be printed only on the hand-press. Publishers of fine books were told that good wood-cut press-work could be had by printing small forms only (never more than eight small octavo pages) on the hand-press, by cutting overlays and by inking the form with hand-rollers or balls. This advice was accepted, but publishers soon found that although hand-press work under these conditions was expensive, it was not always good. Few hand-pressmen could cut a proper overlay.* How to do it could not be taught by rote and rule. If the pressman did not instinctively see the proper relations

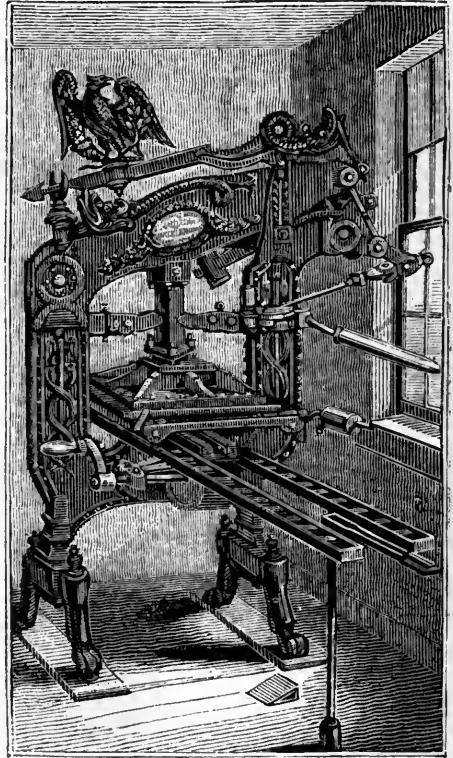

THE COLUMBIAN PRESS.

of light and shade in the cut on which he worked, and did not at once catch the intent of the artist, the overlay he made for it would not help but would spoil the print. Occasionally a pressman of ability produced prints of merit, which increased the amateur's admiration for wood-cuts, but the greater portion of the wood-cut printing done on hand-presses was below mediocrity. Nor did the most successful printing on the hand-press tend to make engraving on wood popular. It did tend to make it impracticable, for it more than doubled the cost of illustrated books. Many publishers discovered that it was cheaper to have illustrations crayoned on stone, or etched on copper, and inserted in the book, in the form of detached leaves; for, on small editions of wood-cut work the performance of the hand-press was but little more than that of the lithographic or copper-plate press, and the quality of the wood-cut work was inferior. In 1835, the admiration for wood-cuts which Bewick had called into life was really declining. It is more than probable that it soon would have died out, if an earnest attempt had not been made to print wood-cuts on machines.

* This interesting, but little-known, process in wood-cut printing will be fully treated in the next paper.

EIGHTY MILES IN INDIANA CAVERNS.

It is stated on good authority, that along the whole Atlantic coast, from Nova Scotia to Mexico, not a single cavity above the present level of the sea has yet been discovered deep enough to give darkness. True caverns are possible only where rocks of much thickness and uniformity of structure, having once been ruptured, are afterward washed out by acidulated water. They are the deserted channels of subterranean streams; and must, therefore, if geological conditions favor, exist on the most extended scale in regions furrowed by the largest rivers. This accounts for the immense and unrivaled openings developed in the limestones of the Mississippi Valley and its noble tributaries, where, as Shaler affirms, "there are at least 100,000 miles of open cavern."

The cave-region of Indiana, whose mysteries my friend Barton and I had agreed to explore, begins forty-four miles above the Falls of the Ohio, which are near Louisville, Kentucky. At Madison, Indiana, the river bluffs boldly rise 400 feet, from thin layers of blue limestone to a crest of massive marble, whence many cascades toss themselves into foam, washing out wide, shallow grottoes, that look exceedingly pretty behind their silvery veils. Occasionally there is a broad amphitheater, whose roof finally falls by its own weight—a process resulting, by repetition, in a steep ravine, and suggesting the manner in which all valleys have been carved, at least in calcareous regions. For twenty miles north of Madison, nearly every ravine has its rock-houses and water-swept chasms. Occasionally true caverns are found whose roof is the solid limestone of the Upper Silurian, while the excavation itself is in the softer rocks of the Lower. One of these is estimated to be a mile and a half long; though, at a point about a thousand yards from its entrance, the roof has fallen in, and the obscure opening, by which access is gained to the ample chambers and winding passages beyond, might readily escape notice. The stream flowing out of this cave runs through the village of Hanover, and then turns capriciously toward the Wabash, from the very banks of the Ohio. Some of the streams of the region, after receiving tributaries and increasing in volume, sud-

denly sink into the sand, or leap down a gorge and disappear, as

"Alph, the sacred river, ran,
Through caverns measureless to man,
Down to a sunless sea."

One such stream is significantly named the Lost River. It pursues its way for miles underground, visible only here and there at the bottom of wild and romantic ravines, some of which are in the depths of the forest. A portion of it has been explored by means of a small boat.

Our errand led us to and fro across several adjacent counties. The scenery is diversified by rolling uplands and rocky glens, forests, and cultivated farms. Large tracts are so thoroughly under-drained as to cause a remarkable absence of springs, brooks and ponds, with an appreciable effect on the vegetation. This is due to funnel-shaped depressions, varying in diameter from a yard to a thousand feet; on the slopes of the larger of these, tall trees are often growing. These are termed "sink-holes," and each has a central opening into some fissure or cavern. This is usually visible on close inspection, but is quite frequently hidden by a clump of brambles, or a marshy pool. Through one of these crevices the plummet went down 125 feet before resting.

Heavy masses of carboniferous limestone lie between the surface and the level of natural drainage, inviting the formation of numerous caves of every conceivable size and shape. Many of these we explored for ourselves. Entering one, we reached before long a lake of crystal purity, whose further wall was impenetrable. Far within another our progress was thwarted by a morass of fathomless mud. From a great gateway, eighty feet wide, introducing us to still another, we found the passage dwindle to a point where we could barely stand erect. This colossal trumpet magnifies the human voice to a deafening volume. A large, swift stream issues from Blue Spring Cave, which we explored for three miles, finding great basins cut down one hundred feet into the rock and overflowing with limpid water.

After a brief rest from preliminary toils, we turned toward the Rothrock farm, five miles from Leavenworth, a village on the Ohio River. From the doors of the

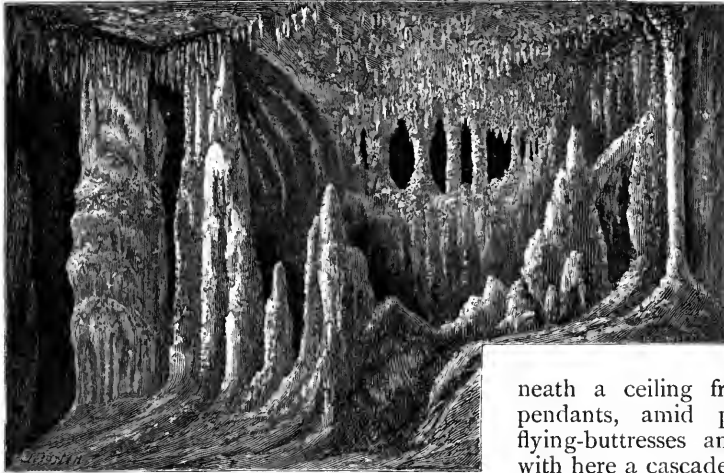

THE PERI'S PRISON, SIBERT'S CAVE.

rural inn that admitted us as guests, are to be seen the mouths of the two most important caves—Sibert's and Wyandot.

SIBERT'S CAVE.

A narrow path, along a ridge shaded by oaks and beeches, leads us to a sink, at the bottom of which is a shaft. Having entered through this, we pick our way amid rocky fragments, and soon find ourselves on a rounded and slippery wall but a foot thick. Along this we creep between two yawning chasms, black as Erebus. A misstep here would be fatal. Midway, we clamber over a smooth, wet stalagmite. Beyond the wall, a ledge six inches wide skirts the left-hand pit. After moving a few yards along this slender shelf we squeeze past a ponderous stalactite that has fallen and lodged against another. The level gallery above can only be gained by laboriously climbing up a treacherous slope. As this offers nothing to be grasped as a safeguard against sliding into the abyss, nicks have been cut to afford foot-hold in the precarious passage. The risk is compensated for, however, by admission into a wilderness of beauty and grandeur. A stately pillar guards the way, ten feet thick and as many high, and its base expands in huge masses of gypsum overlapping the edge of the pit. Nestling by its side, as if for protection, equal in height but only three inches in diameter, rises a smooth, slender shaft of semi-transparent, snow-white alabaster. The floor beyond is strewn with stalagmitic nodules and cones, and occasionally a

prostrate column. One of these once bore the name of the Pillar of Thunder, because when struck by the open palm, it emitted a loud, musical sound; but the last blow detached it from its pedestal, and now it thunders no more. We

wander on, beneath a ceiling fretted with glistening pendants, amid pillars and pilasters, flying-butresses and interlacing arches, with here a cascade in mid-air transmuted into stone, and there clustered columns containing a sculptured cell! This gallery of marvels ends in the Peri's Prison, an exquisite grotto, not more than five feet deep, crossed by a row of pillarets, like the bars of a cage. Red-fire, burned within this dainty cavity, produces a magical effect, throwing roseate hues over the fantastic and snowy piles.

Slowly returning to the pit, we find it more gloomy than ever. But there is no other exit. Steadying myself for a moment on the brink, I turn face downward and search



A PERILOUS PASS, SIBERT'S CAVE

with the right foot for the first little notch, barely large enough for the toe of my boot. Then, letting go the ledge above, I cling to the naked rock with one hand, the other holding the torch, and cautiously lower my left foot to the next notch. Step by step the narrow shelf is gained, beyond which, balancing like an acrobat, I move along on the perilous ridge between the chasms to a place of safety. Looking back, to see how it fares with my artistic comrade, I behold him coolly sketching these underground gymnastics.

We next paid a visit to the hotel table, spread with homely abundance. Then, donning caps and overalls, equipped with lamps and fire-works, line and compass, thermometer and geological hammer, we were ready for Wyandot Cave, probably the largest cavern but one in the known world.

WYANDOT CAVE.

Our guide was Rothrock himself, a genuine Hoosier though of German stock, and full of facts and anecdotes.

"My father was one of the pioneers," said he, as we walked along under the oaks, "and he bought this farm at Government price, the year that Indiana was admitted to the Union. He added to it from time to time until it now covers, as we suppose, all possible entrances to the cave."

"How many acres does the farm include?" I inquired.

"About 5,000," he replied, "but much of it is still uncultivated. Since my father's death, my brothers run the mill and till the land, while I manage the cave and the hotel. My only son, Frank, will be the owner when I am gone."

We forthwith saluted the heir-apparent, a bright little lad who had overtaken us, followed by a tame wolf. The approach of a party of tourists, and their alarm at the sight of this rude pet, consigned him to his kennel, and led one of the ladies to ask the guide if there were many wild beasts in the cave. He assured us that none were to be seen in summer, though in winter a few wild-cats, raccoons, opossums, foxes, and wolves had been known to take refuge there. Bears had formerly shown a fondness for cave-life, and there were places where they had amused themselves by sliding down-hill till the rocks were blackened and polished by their fur!

As we drew near to the entrance, the

artist espied an inscription over the arch, and repeated in Italian, Dante's

"Abandon hope who enter here."

Imagine his chagrin at finding it but an advertisement of some sort of magic oil, instead of the famous line from the Divine Comedy!

Having made one another's acquaintance, with the easy informality of Western life, we took a farewell survey of the upper world, bright in the summer sunshine. The plat-

form of limestone on which we stood was elevated 150 feet above Blue River, visible near the picturesque old mill half a mile away. Around us the primeval forest lifted its aged arms overhanging with matted vines. The rocky ridge above us rose to the height of 500 feet from the valley. The mouth of the cave yawned at our feet. As we entered it, a current of cold air compelled us to guard our lamps, and caused the mercury to fall at once from 80° to 60°. The temperature within, as we afterward discovered, averages 55½°, and remains the same whether the thermometer outside indicates 100° or zero. The breeze, however, varies with the season, blowing outward in summer but the reverse in winter.



R. D. Servoss N. Y.
MAP OF WYANDOT CAVE, CRAWFORD
CO., INDIANA. TOTAL LENGTH,
23 MILES.

ages 55½°, and remains the same whether the thermometer outside indicates 100° or zero. The breeze, however, varies with the season, blowing outward in summer but the reverse in winter.

"This phenomenon," observed an amateur geologist, whom the others addressed as the Professor, "explains the idea embodied by the poetic Greeks in their word for cave, namely, *ἀντρον*, a *breathing-place*: as if these were the nostrils through which Mother Earth inhales and exhales the vital air."

The guide told us that he had left the larger part of the cave in its natural state, only moving loose stones from the pathway, and cutting trenches where the roof was too low for comfort. He next showed us some barrels of salts and saltpeter made from nitrous and magnesian earths that abound here.

The breeze dies away as we go deeper down into the earth. But we experience the benefits of a thorough ventilation, aided by natural chemical processes, which result in an atmosphere wholly cleansed from noxious gases and surcharged with the vital elements. We are soon sensible of its exhilarating influence. The nerves are strung, the pulse is quickened. We enjoy the purity, without the rarity, of mountain air.

And now gigantic forms loom through the darkness. Here is an immense block of stone, with fresh, sharp edges, as if it had just fallen from above, though it probably fell ages ago. Two miles from the entrance, we twist ourselves through the Screw-hole, and stand literally breathless in the Senate Chamber, a room that ends what is termed the Old Cave, in distinction from more recent discoveries. In the midst of the Chamber rises a rocky pile, around which a greater quantity of snowy alabaster has accumulated than in any other place of which the writer has knowledge. Chief marvel in this temple of wonders is the Pillar of the Constitution, forty feet high, seventy-five feet in periphery, and with an enormous base, whose girth is over three hundred feet! This differs from other pillars with which it has been compared, in being not merely incrustated with what one might call a veneering of alabaster, but of a solid, homogeneous mass; it is probably the largest of its kind in the world. The shaft is irregularly fluted from top to bottom, and is girdled by three narrow belts that give it a jointed appearance. The base is studded with blunt stalagmites of various sizes, whose shining tops, as Barton said, reminded him of the cypress-knees of the Dismal Swamp.

A brilliant gallery of stalactitic ornaments extends beyond the great Pillar. A farmer who came in with our party compared them, with rustic wit, to huge beets and parsnips, garnished with sprigs of celery, and suggested to the geologist that this might be the under side of a petrified garden.

"Your similitude is better than your hypothesis," said the man of science. And then, in answer to our further inquiries, he unfolded his own theory, as lucidly as his

fondness for technical terms would allow. Reminding us of the peculiarities of Lost River, he said that in such stream-swept caves these beautiful formations would generally be impossible. Suppose, however, that the river should cut its way through to a lower floor, or be diverted into a new channel, then the water oozing through from the surface, though seemingly pure and clear, would be saturated with mineral substances,



THE PILLAR OF THE CONSTITUTION, WYANDOT CAVE.

which in some instances had been known to be so abundantly deposited as to close up and obliterate caves entirely. Pointing to the water glistening on the tip of the nearest pendant,—

"Should it cling there," said he, "till it evaporates, it would leave a circular deposit of either the carbonate or the sulphate of lime, according to the nature of the materials through which it trickles down. And by a continual repetition of the process, a thin tube would first be formed, thickening by further accretions into a stouter cylinder, and finally into the heavy conical stalactite. The drops coming a little too fast to be retained above, and consequently falling on the floor, make a broader deposit, and there gradually grows up the blunt, firm stalagmite. The process often goes on until stalactite meets stalagmite in a column,

slender and fragile, like some of those in Sibert's Cave, or massive, like the noble pillar at whose base we now stand."

"Stalactites, then," said the artist, "are only icicles of limestone; and icicles are but stalactites of water."

We slaked our thirst at a crystal reservoir, scooped from the crown of a stalagmite, and filled by falling drops. A goblet rested on the rim of this dainty fountain, which each tried in vain to lift from the stone to which it was sealed by a transparent film. This is one of several experiments for measuring the rate of calcareous deposits, with some hope of estimating the age of the cave itself. Their growth is found to vary according to the strength of the lime-water and the rapidity of evaporation. In this locality points of stalactites, marked twenty-five years ago, have advanced during that period one inch, while stalagmites have grown but one-fourth of an inch.

The weight of the immense mass of alabaster, composing this pillar and its adjuncts, caused the pile of rocks that had previously fallen to settle beneath their burden; and this, in turn, cracked the base, opening in it crevices many yards long, and varying in width from an inch to a foot. Starting from these, a segment has been cut having an arc of thirty feet, and a cavity made in the column itself ten feet wide, seven feet high, and five feet deep. This work has been hitherto regarded as a deliberate plan of the saltpeter miners to fell this noble shaft. I have a different explanation. Tracing the right edge of the cut, we found it running underneath a stalagmitic wrapping, eight feet wide and ten inches thick at its thickest part. Inspection showed that the incision was made through a mass similar to that by which it is now overlapped; and as the rate of growth does not exceed one inch a century, we infer that the excavation, instead of being made in 1812, was made 1000 years ago, or, to be more exact, was then completed. Following the talus of pure white stones that have rolled down under the ledges of black limestone, we found them sometimes cemented over cavities where nature has had time to produce clusters of exquisite stalactites, like fingers of opal. These must have grown since the quarry was worked, thus confirming our conclusions as to its great antiquity. Further search revealed even the implements with which the ancient workmen (whoever they were) wrought, namely, numerous round or oblong granite boulders,

extremely hard, and of a size suitable to be grasped by the hand, or twisted in a withe and swung as a maul. They could not have been carried to the end of the cave by the action of water, for the interior is here twenty feet higher than the mouth. The region, moreover, is south of the line of glacial drift. It seems certain, therefore, that they were brought hither from a distance by persons having access to no better tools. Their ends also are battered and whitened by use as pounders. It is my conclusion, therefore, that from this alabaster mine blocks of a convenient size were carried away by successive generations as a choice material for ornaments, amulets, discs, and images. Those who wrought here by torchlight, so long ago, may have been of the same race that dotted the Ohio Valley with mounds, whose era agrees with the date of this mine as now estimated. A powerful nation once held these sightly terraces, where they built stone forts of formidable dimensions, one of the largest of which is not many miles distant from Wyandot Cave. In the Southern States ornaments of alabaster have been repeatedly exhumed among Indian relics; and more careful research may find similar objects amid the tumuli of Indiana, though perhaps not abundantly. For alabaster, though a very durable material when not exposed to the elements, is fibrous in its nature, and would be liable to decay amid the frost and sunshine of ten centuries, as we know from the crumbling specimens found outside near the cave.*

The next morning we made an early start, for we had a long day's march before us. Two students joined our party; also the heir-apparent, attended by Don, the house-dog, more acceptable than his wolfish rival. A servant followed with a basket of provisions. Passing by various objects, we crawled through a low door to the right of Bandit's Hall, and by a rapidly descending path were led into Bat's Lodge, which is the lowest point in the whole cave, being more than 400 feet beneath the crest of the hill, and only twenty feet above the high-water mark of Blue River. Pausing here, on the threshold of the New Cave, Rothrock gave us a few facts of a historical nature.

The Main, or Old, Cave had long been an

* The scientific bearings of the above discovery have been more fully treated by the author in an article in the "American Journal of Science and Art," Nov., 1878.

object of especial attention, and had numbered among its visitors Owen, Agassiz, and other distinguished persons. A party from Fredonia, Ind., in 1850, observed a current of air from a small opening, where also numbers of bats were seen to pass. By removing a few loose stones the scuttle was

it with such force as to kill themselves in large numbers.

Climbing a rugged hill we reached a spacious hall, whence two main arms branch in opposite directions. We followed the guide into the South Arm. Here, as he told us, the first white explorers found a well-

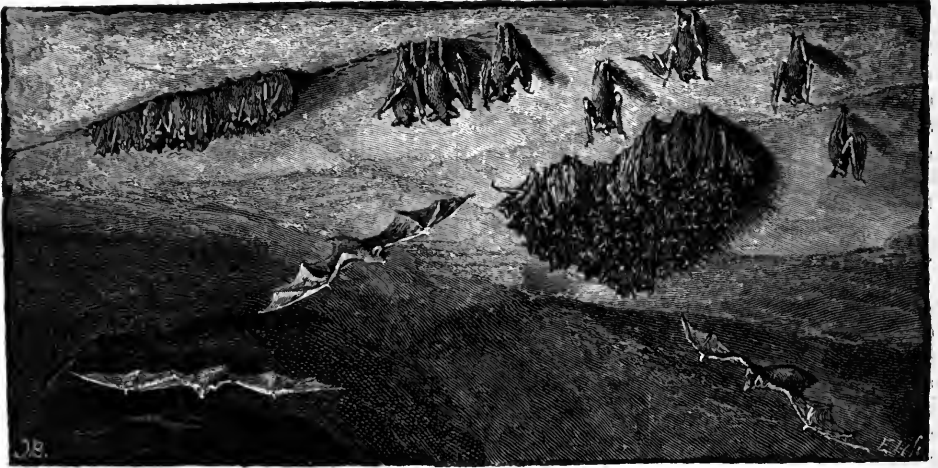

A COLONY OF BATS, WYANDOT CAVE.

found through which we had just made our way. It had the appearance of having been previously used, but afterward closed up, either purposely or accidentally. Thousands of bats were found clinging to the walls, clustering together like swarms of bees. The little creatures continue to make it their resort, especially in winter. A large cluster was pointed out, containing several hundred bats as close to one another as possible, and all hanging head downward. The general appearance was that of a mass of brown fur. Barton rubbed his hand over the mass, thus causing every little red mouth to fly open, displaying needle-like teeth. The transformation of color was startling. A chorus of quaint cries now arose from the peaceful colony thus disturbed; and several of the winged gnomes, unhooking themselves from the wall, flew about our heads eliciting feminine shrieks only a little less shrill than their own. The result was that we left them to the quiet enjoyment of their lodge. It was interesting, both here and elsewhere, to watch the queer little creatures as they flew through the darkness without hitting the projecting rocks. But it is said that when the proprietor once fitted an oak door into the entrance (now removed) the bats flew against

beaten path, smoke-stained walls, charred bits of hickory-bark amid the *débris*, poles from five to eight feet long, and other proofs that the Indians had preceded them. Some of these relics we picked up for ourselves. We were fortunate in finding numerous poles, all of them saplings, pulled up by the roots and with the branches twisted off. No sign of an edge-tool could be found upon them, but many prints of sharp teeth probably left there in some combat of yore between savage and brute. The farmer, on examining the wood, said that none of the poles were hickory or oak, but poplar, sassafras, pawpaw, or some other variety of soft wood.

We had now traversed two halls of considerable size, called the Dining-Room and the Drawing-Room, whose walls and ceiling were almost as smooth as if finished by the trowel and float. The cave soon subdivides, re-uniting three-fourths of a mile beyond; it thus encircles the Continent, while similar but smaller masses of cave-girt rock are called islands.

The chief hall in the western branch is the Wyandots' Council-Room. One of the students here inquired whether this cave had really been resorted to by the tribe whose musical name it bears. Rothrock

replied that according to tradition, the Wyandots held this region long ago, and that they were driven, by a more warlike tribe, northward to hunting-grounds along Lake Huron, leaving only their name on the waters of what is now called Blue River. A Mr. Wallace, one of the early explorers, familiar with this legend, transferred the appellation to this famous cavern, and to the amphitheater we had now entered. The guide then made its dimensions visible by burning red-fire, magnesium, and other illuminants, and we estimated it to be 700 feet in circumference and 50 feet high—an unbroken arch without a single supporting column! Belts of black flint stand out in sharp contrast with the whitish-gray walls.

On the right is found a heavy bank of indurated clay, deposited long ago by some stream that has ceased to flow; for in this portion of the cave all is now as dry as a brick-kiln. Through this bank the guide had lately dug a narrow trench, and we were the first visitors whom he had invited to enter. Flat on our faces, two or three of us sprawled and twisted our way through. But we had our reward. The opening led to a small room, about forty feet square and eight feet high, where no white man had preceded us. Imagine our sensations on seeing the floor thickly strewn with fragments of hickory bark! Overhead, in a crevice in the low ceiling, were sticking two torches with charred ends. The genuineness of the relics was beyond a doubt. These extinct flambeaux were probably last touched by mortal hand before the keel of the vessel that bore Columbus had grated on the sands of the new world! There is no probability that the place had ever before been entered through the clay-bank, which could only have been formed when great



A SPECIMEN OF OULOPHOLITE, EXCAVATED IN DIAMOND AVENUE.

volumes of water were pouring through these now dusty channels.

The roof at the farther end has evidently fallen in, as is apparent from the bent strata curving down to the floor, and the scattered blocks of limestone, with here and there an opening between. Our compass told us that the closed avenue once led to the fallen rock near Bandits' Hall, and within 1,200 feet of the mouth. Every nook and cranny was faithfully tried, but only one led us any considerable distance. And here, in the soft, nitrous earth beyond the clay, were the tracks of some kind of wild beast, leading to an empty lair! These signs interested Don, who now took the lead, bristling and growling in momentary expectation of a foe. But none appeared, and we had no means of telling whether the tracks had been made recently or at some remote time, for no natural causes now operate, in these dark crypts, to efface an impression once printed on the floor. This incident led us to name the new room the Wolf's Lair.

Rejoining those who had tarried for us in the great Council-Room, we proceeded to the lower end of the Continent, where there is a large mound surmounted by detached rocks, one of which bears a whimsical resemblance to an alligator, while another is shaped like a hippopotamus.

We next traversed a long hall conducting us to a pile of gypsum-coated stones, wet with spray from a cascade near by. On top of the pile is a marvelous and symmetrical throne. The seat itself consists of a circle of small rounded stalagmites cemented together. Above it, at the height of six



CALCITE CRYSTALS FROM MILROY'S TEMPLE, WYANDOT CAVE.

feet or less, is a corresponding circle of broad, leaf-like stalactites, shooting over from a shelf near the ceiling, and hanging

The orifice to which I pointed was midway between the floor and the roof, and plainly enough to be seen; but visitors were de-



THE ALLIGATOR, WYANDOT CAVE.

in graceful folds like drapery. On each side of this canopy is a continuation of the fern-like stalactites in a reflex curve, extending for about six feet. The edges are all turned outward, and the leaves are thickly crowded together.

Crossing the muddy beds of two streams where the water often flows, now however empty, we found ourselves in Diamond Avenue. Here nature asserts her power to work miracles of beauty from cheap materials, transforming gypsum and epsom salts into lustrous crystals that sparkle on the walls and lie on the floor. The guide even digs up from the earth, as carelessly as if they were potatoes, crystals like nails, and needles, and others as fine as spun glass; sometimes they are exquisitely curled and wreathed.

"There seems to be an opening beyond," said I to Rothrock, as we stood by a deep flint-pit, not far from this mine of gems.

tered from entering, because of a fallen stalactite weighing several tons, that hangs over it caught by its tips.

"Let us explore," said the artist. "The rock for years has thus been suspended like Mahomet's coffin, and surely will not be so spiteful as to fall on us at last."

We accordingly crept on our knees under the impending mass, without giving it the slightest touch, and entered a wild, lofty vault, extending upward for nearly eighty feet through the solid limestone, enlarging itself here and there into cells and grotts, all splendidly draped with stalactites. We named it Helen's Dome, in honor of one of our party.

The terminus of this arm of the cave was but a few yards distant, where the way was blocked by a huge mass of alabaster, curiously carved in concentric rings. It is plainly the base of a pillar that rises into an invisible chamber, to which no entrance



THE PILLARED PALACE, WYANDOT CAVE.

has yet been found through the frowning rocks.

Returning another way, among ribs of limestone that uphold a deeply corrugated roof, we are presently ushered into a place of singular beauty called the Pillared Palace. Stalactites have clasped stalagmites, thus forming snowy pillars. These support an ornate entablature of alternate belts of marble and flint, over which are graceful pendants. Fragments of fallen columns encumber the floor, among which we found pounders similar to those before mentioned.

"These places have always been called so," said he, "and they must have been made by something or somebody."

"No doubt," I replied, examining one of the wallows critically, "but can you tell me why there should have been a little pile of ashes and charcoal on one side of each bear, and a heap of flint-chips on the other?"

The answer to this query was a general and eager search with quite interesting results. Bands of flint had already been noticed, sometimes in continuous belts, but often in rows of nodules, varying in diameter

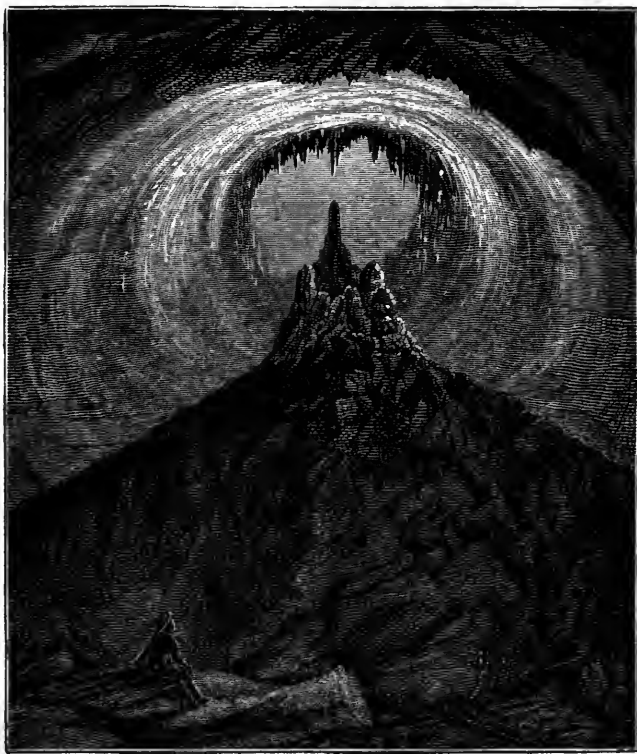

ROTHROCK'S CATHEDRAL, WYANDOT CAVE.

While the artist was sketching the Palace, the guide exhibited to the rest of us some remarkable depressions, about twenty in number, each being a yard wide by a foot deep. These, as he said, were the bear-wallows. But we were growing incredulous, and disposed to judge for ourselves without regard to what had been told to travelers for the last quarter of a century.

"Bear-wallows!" said I, repeating his words, "what would bears want to wallow in here for, all in the dark, when there were plenty of sunny banks outside?"

from one to ten inches. Rarely, they have a geodic form and a crystalline center, showing that the silicious particles had collected about a nucleus. Between these belts or rows there is usually a chalky substance, easily cut with a knife, or even by the finger-nail. The so-called bear-wallows are where the flint is most abundant and of the best quality. Here also pounders had been used to crush the nodules, which generally break with an even fracture. The ground was covered by a thin coating of clay, beneath which hundreds of flint-blocks were found; each

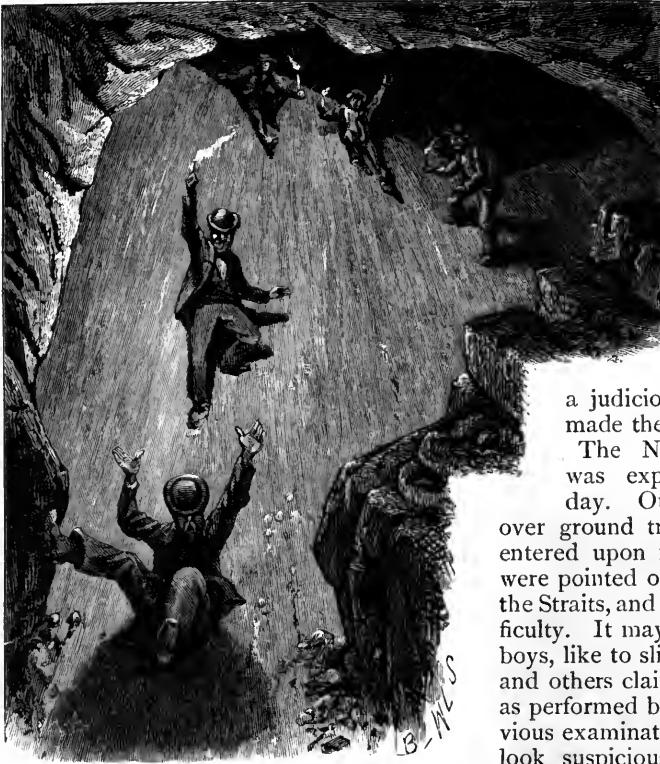

SLIPPERY HILL, WYANDOT CAVE.

piece having parallel faces, and averaging four inches in length, one or two inches in width, and one-half inch in thickness. They were doubtless split by the Indians from the oval nodules, as materials for arrow-tips or spear-heads. The only manufactured article found by us was a small stone saucer that had once held some black substance. The place was plainly a mine and not a factory. Subsequent search at the mouth of the cave unearthed from the *débris* numerous finished arrow-heads and quantities of flint-chips, such as the old arrow-head makers used to spring off from the block by abruptly handling creased tips of buck-horn.

By way of Creeping Avenue we emerged into halls already traversed, and were rapidly going toward the mouth of the Cave, when Frank gave the alarm that Don was missing. No one had seen him since our leaving Wolf's Lair. An attendant went back with the disconsolate lad, and we saw no more of them until their return to the hotel after dark, when they reported that they had found the poor dog exactly where he had been left. His instinct prompted him to remain where he was until found, instead of breaking his bones, as a rational

human being would have done, in futile efforts to get out. The rescuers narrowly escaped the fate threatening the rescued; for the dog, in his grateful capers, knocked their candle down, and it was lost. But the inexhaustible treasures of a boy's pockets are proverbial, and Frank, by searching among marbles and other toys, found a candle-end and a few matches, by

a judicious use of which they barely made their way out.

The Northern Arm of the cave was explored by us on the third day. Our path ran for about a mile over ground traversed before, and then we entered upon new scenes. "Bear-slides" were pointed out to us near the entrance to the Straits, and during the ascent of Hill Difficulty. It may be true that bears, as well as boys, like to slide down-hill; and Dr. Kane and others claim to have witnessed the feat as performed by Polar bears. But our previous examination of the wallows made us look suspiciously at those blackened and polished rocks. Though unable to explain the mystery, we were inclined to hold the Indians responsible for them. The slides are certainly there, and with sundry slips and bruises we clambered over them.

Suddenly the low roof is lifted, and the rocky pile grows to mountainous proportions. We have entered the solemn precincts of Rothrock's Cathedral. Toiling up the steep, one hundred and thirty-five feet in height, our lamps shine across the jutting points a little way, and then lose their rays in Stygian darkness. The summit is crowned by an irregular inclosure of stalagmites, rising, at the farther end, into an alabaster pyramid, on which stand three statuesque figures that are respectively six, seven and eight feet in height. The tallest one is quite dark, while the other two, on lower pedestals, are draped in spotless white. In the side of the pyramid is an incision like that in the Pillar of the Constitution, and by careful search we found the granite pounders as before. Ignited magnesium made the cave as light as day, and brought to view the proud arch springing 205 feet from the base of the mountain, thus forming Wallace's Dome, and closing around a smooth elliptical slab of oölitic

marble, sixty feet long by thirty wide, finely contrasting with the darker limestone, from which it is divided by a deep rim, fringed with long stalactites curling like leaves of the acanthus. Far around us, with strongly marked strata, varying in hue and thickness, bends the massive wall of this venerable cathedral in a symmetrical oval one thousand feet in circumference!

Piloting us down the northern side of the hill, the guide left us conveniently seated at the foot, and collecting our lamps returned to the summit. Then followed several extraordinary transformation scenes. By concealing fifty or more lighted candles around the pyramid and behind adjacent rocks, he made us fancy that we saw a city by night, with castellated walls, illuminated windows and flame-lit spires. He next grouped the lights in a cavity, and by a skillful use of red-fire and Roman candles simulated the appearance of a volcano in active eruption. But his masterpiece was

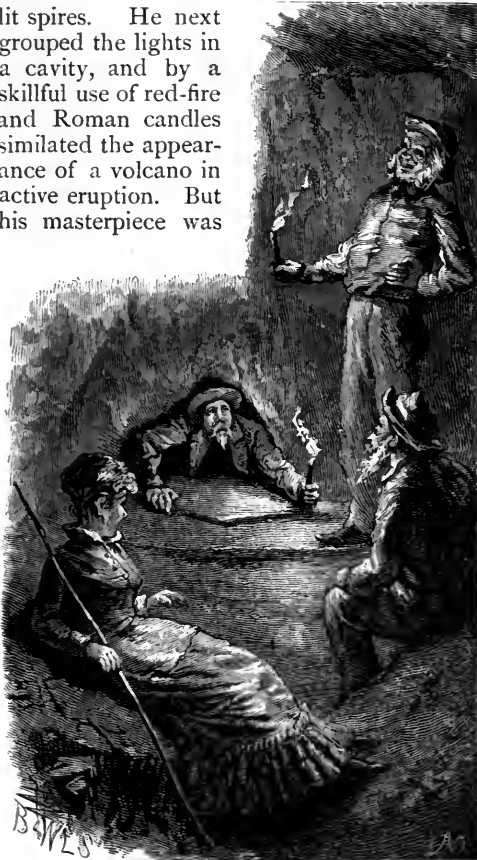

THREADING THE AUGER-HOLE, WYANDOT CAVE.

a lavish blending of colored fire-works, creating a magical scene of enchantment. Near us lay a craggy wilderness, above which towered the pyramid, whose spectral figures stood out in relief against the oval

dome; the general background being the great wall with its variegated belts, encircling the entire basilica, amid whose arches ascended roseate clouds of smoke wreathing the twisted stalactites and curling acanthus leaves, in bewildering contrast with the black shadows cast by the beetling ledges—an indescribable vision, as if an opening had been made into realms of supernal splendor.

"Beyond the magic of Aladdin's lamp!" cried Barton.

"A petrified sunset!" exclaimed the Professor.

"The gate-way of Heaven!" said his wife.

"Rothrock's Cathedral forever!" shouted the guide, descending with our lamps, and conducting us to a spring, beside which lunch had been spread by the servant.

While partaking, we gave ear to another chapter of cave history. It had long been conjectured that there was an extension of the cave in a line with the axis of the Cathedral, that runs nearly N.N.E., but no opening had been found leading more than ten yards. Finally, amid a group of bulky stalagmites crowded against the wall, a hundred feet to the right of the rubbish blocking the original way, an orifice was detected by the current of air issuing from it. This, on being enlarged by the owners of the Cave from six inches to twenty-one inches, admitted them to many miles of new territory. The aperture is called the Auger-Hole; and at the estimated rate of stalagmitic growth it must have been impassable for a thousand years prior to its recent widening. Yet in the nitrous earth beyond, soft as a newly raked garden-bed, they found the moccasin tracks of a party of Indian explorers who had once searched the avenues, going up on one side and down on the other.

The opening is far from inviting, splashed as it is by the overflowings of the spring, and yawning like a monster. The Professor asks if we really must descend as Bruin slips into a hollow tree,—the very thought calling forth a storm of feminine protests. The guide says that they must either back in or else back out! One of the students, slender as a reed, and lithe as a cat, sets the example, by turning on his face and disappearing feet foremost. Soon he calls from some invisible place, assuring us that the tunnel is less than fifteen feet long; and then we hear his footsteps retreating through the corridor. The ladies conquer their fears, and the gentlemen follow. The

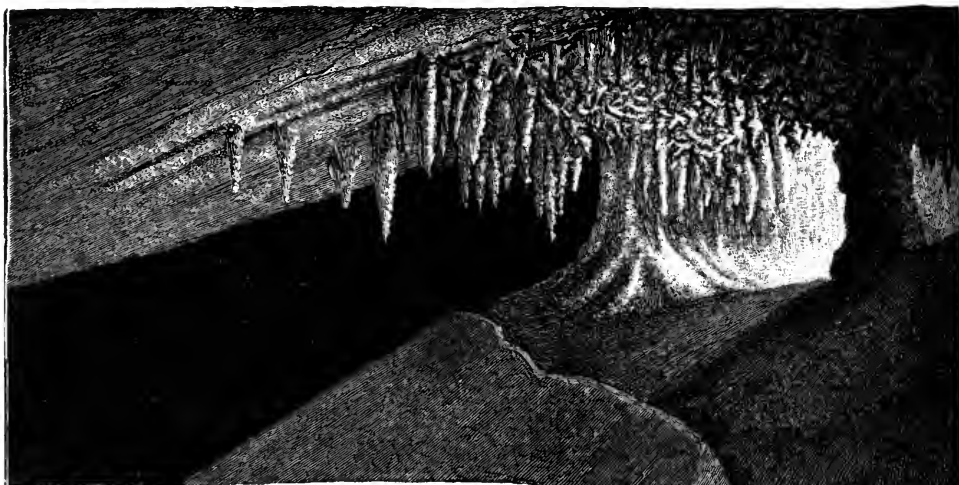

portly farmer brings up the rear, but, when half-way through, he is caught fast in the rocky embrace, and cries lustily for help. The guide pulls him through, and is repaid by being told that the Auger-Hole is a great bore!

Beyond this is Slippery Hill, another place of merry difficulties, about which many a racy story is told, and then a succession of halls, galleries, and avenues, each with its own peculiarities. At the Crawfish Spring we linger to catch the eyeless creatures, that were either formed amid these limited waters, or have been modified since floating down from upper streams; for now they are utterly destitute of the organs of vision, and are perfectly white.*

From a curiously water-carved vestibule we enter the Frost King's Palace, where every object, large and small, is crustated with sparkling gypsum. Brilliant effects are thus produced in this and other halls,



MILROY'S TEMPLE AND WORM ALLEY, WYANDOT CAVE.

* These, and other cave fauna, are described in the reports of the State Geological Survey, which also contain valuable general observations on the caves of that region.

AN INVITATION.

O' COME into the garden, sweet,
At dawn of day, at dawn of day;
For Love has the key of the postern-gate,
Make no delay! make no delay!

Here's beds of roses white and red,
Where softly shall you fare.
Here's crowds of yellow marigolds
To deck your shining hair.

Here's meadow lawns and grassy plots,
Where dainty feet may stray,
Here's doves to coo, and birds to sing
Love's tender roundelay.

Here's peaches from the southern wall,
O sweetheart, taste and try.
Here's arbors green and trellises
To kiss, and no one by.

And all these things await you, love,
At dawn of day, at dawn of day;
For Love is here with song and lute.
Make no delay! make no delay!

THE ORCHESTRA OF TO-DAY.

NOT long ago, a flute was found near Poitiers, in France, among surroundings which pointed to the age of prehistoric man as the epoch of its construction. It lay among the implements of the stone age, and was merely a piece of stag's-horn pierced with three holes which gave it a capacity of four tones, without counting possible harmonics. The utmost discoursing of this rude instrument must have been but trifling compared with the weighty message of its silence, as it lay there among its uncouth axes and knives; for it told the strange story of instrumental melody backward to a point beyond history, and hinted that man commenced to hunger for music about the same time as for bread. But along with this antiquity of orchestral constituents, the thoughtful musician finds the seemingly incongruous fact that what we call the orchestra is the product of only the last two centuries. How is it that melody is so old, and harmony so young?

The answer to this question involves considerations extending to the very deepest springs of modern life, and leads the investigator into directions little suspected at the outset. It would require far too much space to be attempted here; but before proceeding to set forth—as the main body of this paper is intended to do—a plain and untechnical account, for non-musical readers, of the nature of orchestral instruments and the work of their players, I wish at least to

state the problem clearly and to call the reader's attention to some circumstances which look toward its solution; hoping thus to present a nucleus about which the scattered items of fact to be subsequently conveyed may group themselves into portable form.

Consider, for example, how persistently the human imagination, whenever it turned at all in the direction of music, for long ages addressed itself to gigantic speculations upon the power of it, rather than to the more satisfactory business of expressing itself immediately in terms of the musical art. Instead of making music, it made a great ado about music. Hence we have (practically) no remains of ancient music; but what a lot of fables, often beautiful and noble, upon it! Compare for a moment a whole mythology of these with the fruits which the modern mind brings out of the same realm: the results are striking enough. From the modern musical imagination we get, not fables about melody, but melodies; not unearthly speculations upon music, but actual unearthly harmonies; not a god playing a flute, but the orchestra.

Why has this immense development of music occurred in our particular modern age, rather than in some other?

It is already commonplace to say that what we call the modern epoch is contradistinguished from all others by the two characteristic signs of the rise of music and

the rise of science. This contemporaneity of development cannot be a merely accidental coincidence. That same scientific spirit of which the modern time has witnessed such an influx that one may not irreverently term it Pentecostal is the stimulus which, acting in one direction, has produced the body of modern music, in another direction the body of modern science. For, if the scientific spirit be but a passionate longing to put oneself in relation with the substance of things—with the truth as it actually exists outside of oneself, then it is easily conceivable that such a longing might influence very powerfully both of those two great classes of man's spiritual activities which we are accustomed to call, the one intellectual, the other emotional; and that, driven by such a longing, intellectual activity might result in science, emotional, in music.

We all know how invariably, from of old, every attempt to draw near to the substance of things has ended in quickly bringing the investigator to the same awful term, to wit—God, though the investigator has often named it far otherwise. And—if such be the real outcome of science—can any one attend, on the other hand, to an intelligent rendition of the Fifth Symphony without finding beneath all its surface-ideas this same powerful current of Desire which sets the soul insensibly closer toward the Unknown by methods which are inarticulate and vague, as those of science are articulate and precise?

Moreover, when looked at from the standpoint of any large classification of eras, we find the musicians and the scientists about shoulder to shoulder in time; we find Copernicus, Galileo, Newton, Descartes, De Maillet, Haller; Hunter, Harvey, Swedenborg, Vesalius, Linnæus, Lamarck, Cuvier, Buffon, Franklin, Hutton, Lyell, Audubon, Faraday, Helmholtz, Agassiz, Le Conte, Huxley, Tyndall, Darwin, to be substantially contemporaries of Palestrina, Purcell, the Scarlattis, Handel, Bach, Gluck, Haydn, Mozart, Beethoven, Cherubini, Schubert, Von Weber, Mendelssohn, Spontini, Spohr, Rossini, Berlioz, Schumann, Chopin, Glinka, Gade, Kuhlau, Boieldieu, Rubinstein, Raff, Gounod, Hamerik, Wagner.

In truth—and with this suggestion one can now come to the more immediate purpose of this writing—perhaps it will finally come to be seen that if we shred away from music and science all that manifold husk of temporary and non-intrinsic matters which envelops the nut of every important movement, we will

find both presenting themselves as substantially the forms in which the devoutness of our age has expressed itself—that devoutness without which no age *is*, and which comes down from one to another in imperishable yet often scarcely recognizable shapes; insomuch that our great men are as it were but more sensible re-appearances of monks—our musicians having retired for worship into music, as into a forest, and our scientific men sending out the voice of uncontrollable devotion from a theory, as from a Thebaïd cave.

The instruments of which a full orchestra is composed are of three general classes: "the wind," "the strings," and the "instruments of percussion."

To begin some account of the first-named class: perhaps nothing is more perplexing to one unfamiliar with orchestras than the goings-on and general appearance of the wind-side of it; the shapes of the instruments seem grotesque, and the arrangement of the keys on a Bœhm flute (for example) or a bassoon seems utterly lawless and bewildering. But perhaps by reducing all wind-instruments to one common type, and then clearly setting forth the precise manner in which air, when set in musical vibration by the human breath or otherwise, is definitely controlled to this or that pitch, much of the embarrassment of this apparent complexity can be avoided.

Let this common type, then, be a straight tube of wood, closed at one end, say two feet in length and an inch in diameter, pierced with a hole at the distance of an inch from the closed end, after the manner of a flute embouchure. Let the lips now be applied to this embouchure, and a stream of air constantly increasing in force be sent across it. The first tone heard will be the lowest tone of which the tube is capable; from a tube of the dimensions named, this lowest tone will not be a great way from the middle C of the piano-forte, and we will here assume it to be exactly that C. Now, most persons who have not reasoned upon the subject are found to expect that as the breath increases in force a series of tones corresponding to the ascending scale from C will be produced. But this is far from being the case; on the contrary, the tone first produced will grow louder and louder, until suddenly its octave will sound, and no management of the breath can by any possibility bring out an intermediate tone between this normal C and its octave. If the force of the breath be still increased, pres-

ently the *g* above this octave will be heard ; if still increased, the *c* above this *g* ; still increased, the *e* above this last *c* ; and so on, in a series which I will not here further detail. This process is typical for all tubes, of whatever size or material, and however the air may be agitated in them. Its explanation forms one of the most striking triumphs of modern science, but is too long to be given here.

It appears, then, that our tube gives us already five tones, without any appliances whatever except the simple expedient of increasing the force of the breath. Suppose, now, that we shorten it by cutting off about an inch ; on applying the breath gently at the embouchure, the first tone heard will now be D (the next tone in the scale to the C first mentioned) ; and if we continue to increase the force of the breath, as at first, a series of tones will be heard bearing the same relation to D as the first series bore to C, that is, the *d* octave of D, then the *a* above this *d*, then the *d* above this *a*, then the *f* sharp above this *d*, and so on. If we should again shorten the tube by about an inch, then the first tone heard will be E, or the second tone in the scale above the first C of the long tube ; and, again forcing the breath, another series exactly similar to the last will be produced. It would thus seem that in order to produce those intermediate tones of the scale needed to fill up the gap between the first C and the octave of it, we are under the necessity of shortening the tube inch by inch. And so we are, but there is a method of shortening the tube which does not involve cutting it off. Piercing it with a hole of from an eighth to a quarter of an inch in diameter is found to have the same effect as if the tube were cut off at the point where the hole is pierced, and this discovery affords an easy method of producing on one tube all the notes belonging to the gap between the two extremes of the first octave ; for, instead of shortening the tube by cutting it off, we successively shorten it by piercing holes at the points where it ought to be shortened. If we cover all these holes with the fingers, the tube is practically two feet long, and will give, on being blown, the C first mentioned ; if we then open the hole farthest from the embouchure by lifting up the finger which covers it, the tube becomes practically shortened by an inch, and gives us the next tone in the scale, D, which we can then vary with all the hitherto enumerated changes which it undergoes by

merely increasing the force of the breath. If we lift up the next finger, we again practically shorten the tube by an inch and get the next tone of the scale, E, together with its upper tones or harmonics. It will be observed that in obtaining these first seven tones from the normal C to its octave, we have really obtained an instrument capable of thirty-five tones, for each of the first seven represents not only itself but the four harmonics producible by merely forcing the breath upon it without changing the position of the fingers. In practice, some of the higher tones of these harmonic series are found not to be available—for reasons too abstruse to be mentioned here—but the lower ones are, and it is upon a combination of the principle which they involve with the principle of shortening the tube to make the first octave, that all wind instruments are constructed. In the case of the trombone, one sees the performer actually shortening and lengthening the normal tube, which is in two parts, one sliding into and out of the other like a telescope-joint. In the other brass instruments the long normal tube is bent into several crooks which can be thrown into one tube or successively shut off to diminish the aggregate length, by means of the pistons or valves which the performer works with his finger.

By remembering, therefore, these three things : that the shortening of a tube heightens the pitch of its tone ; that a tube may be shortened either by holes in the side (as in the flutes, the oboes, the clarionets, the bassoons), or by shutting off some of its crooks (as in the horns, the trumpets, and the like), or by directly contracting its length, (as in the trombones) ; and that each of the tones of the lowest (or first) octave produces from two to five other tones by simply blowing it more strongly, the reader will understand the principle, varying only in details, which underlies the whole wind-side of the orchestra.

The two largest classifications of the wind-instruments are called among players "the wooden wind" and "the brass." The first of these is further subdivided into the reeds and the flutes. And first of the reeds, about which I find the haziest ideas prevailing, even among the oldest frequenters of orchestral performances.

The reed-instruments in common use are the oboes (or hautboys), the bassoons, and the clarionets.

The oboe is an instrument somewhat like, the familiar clarinet in appearance, but of

a slenderer make, and differing entirely at the mouth-piece. This is composed of two delicate pieces of reed, shaven quite thin, in shape much like the blade of an oar, and bound face to face. These pieces are attached to a quill which is inserted in the small end of the oboe tube. The mouth-pieces are usually kept separate from the tube; when the performer is about to play, he opens a small box in which they are protected from exposure, and proceeds to select one by sucking each through the quill. That one which first responds with a squeak is chosen; the quill is inserted in the tube, and the mouth-piece is placed between the lips, the under-lip being slightly drawn in. Much practice is required to become accustomed to the tickling of the lips produced by the fluttering of the thin reeds as the breath is forced over them. The tone of the oboe, though intolerably nasal and harsh when produced by an unskillful player, becomes exquisitely liquid and engaging if the performer be skillful. It is peculiarly simple, child-like and honest in quality, and orchestral composers delight to use it for expressing ideas of spring-time, of green leaves, of sweet rural life, of all those guileless associations connected with the antique oaten pipe. Those who have been so fortunate as to hear the rendition of Berlioz's "Dream of an Artist" will remember the exquisite passages in which the oboes represent the pipings and replings of shepherds to each other from neighboring hills. In Schultz's concert-piece called "*Im Freien*" ("In the Open Air"), the two oboes lead off in a lovely candid opening which seems to infuse one's soul with the very spirit of young, green leaves, and of liberal spring airs.

The bassoon is a long wooden instrument held vertically in front of the player and running down along his right side. From the wooden portion projects a small silver tube, bent somewhat like the spout of a kettle, into which a mouth-piece similar to that of the oboe is inserted. Both the bassoon and the oboe are called double-reed instruments, in distinction from the clarinet, which has a mouth-piece constructed of a single reed. The bassoon has at least two very distinct qualities of tone; in the upper and lower extremes of its register it is weird and ghostly, but in the middle portion warm and noble. For the production of ghostly effects, for calling up those vague apprehensions of the night, when church-yards yawn, and the like, it is much used by composers.

In a singular passage of the "Artist's Dream," hereinbefore mentioned, it is made the interpreter of a colossal, grotesque and inconsolably bitter sorrow. The beauty of its middle register seems not to have been much employed; but no one can listen to the ravishing bassoon-solo in the slow movement of the concerto for piano and orchestra by Chopin which Madame Schiller and Thomas have made known to northern audiences, without perceiving in this portion of the bassoon's compass a very remarkable combination of gravity and sensuous richness—a combination much like that suggested when we think of a very stately young Spanish lady, high in blood and in color, and grandly costumed. This instrument usually appears on the orchestral score as *fagotto*, Italian for fagot, so-called from the resemblance of its lower portion to such a fagot as might result from binding two stout pieces of wood together with a metal band.

The clarinet is, as was above remarked, a single-reed instrument. This single reed, instead of playing against another reed like itself, as in the oboe and bassoon, is simply bound alongside of the beveled plug which closes the small end of the clarinet-tube, leaving a narrow slit between the reed and the plug. The player usually has three clarinets standing at his side: two of these are constructed of a different pitch from the other non-transposing instruments of the orchestra, so that the same written note when played by them gives a wholly different sound. The reasons for, and details of, this arrangement would lead this paper beyond its scope; and it will suffice to add that these three clarinets are known as the C clarinet, the A clarinet and the B flat clarinet, being so-called from the tones of the other instruments with which the C of each variety coincides. Thus, if you sound a written C on the A clarinet, the resulting tone is the same as the written A of the other instruments; if you sound a written C on the B flat clarinet, the resulting tone is the same as if the other instruments had played a written B flat, and so on. It is proper to add that in modern times clarinets have been made in other keys—that is, have been made with such lengths of tubes that their C's would respectively coincide with other tones in the first octave of the other instruments; but the three above named are those almost universally used in non-military orchestras.

Of course, the proper allowance has to be

made for this peculiarity of the clarionet's construction in writing for it. The player always finds the words "A flat clarionet," or "B flat clarionet," at the head of his part, indicating which one of his instruments he is to use; and the composer has to vary the key accordingly, all the clarionets except the C clarionet necessarily playing in a different key from the other instruments.

I have spoken of this peculiarity of the clarionet—although unable here to explain or detail it—particularly for the purpose of making intelligible to the reader what I shall presently have to say with reference to the work of the conductor of an orchestra.

The tone of the clarionet will be easily singled out by most persons from among the mingling voices of the orchestra, by its penetrating sweetness in the highest part of its register, its liquid-amber quality in the middle part, and its reedy but pathetic mellowness in the lower part. No one will fail to be struck with the peculiarly feminine character of its higher utterances.

Besides the clarionets already named, large orchestras often employ the bass-clarionet. The name of this instrument indicates its nature; its tube is longer and larger than that of the others, and yields a tone much lower in pitch, though of similar quality.

Having thus given a most meager outline of the reed-division of the "wooden wind," it will not be necessary to say much of the other division, which is much more familiar—the flutes. It will be useful, however, to describe the Bœhm flute—the modern form of the old-fashioned flute—inasmuch as many persons are unacquainted with this most happy of all the more modern improvements made in orchestral instruments. For a long time the flute was a black beast in the orchestra; it could not be made perfectly in tune throughout its entire compass; insomuch that all sorts of bad stories (such as that there was but one thing in the world worse than a flute, to-wit: two flutes—and the like) were told of it. The reason of this inability to make the flute wholly in tune was this. In consequence of the peculiar formation of the hand, the fingers would be unable to adjust themselves to the holes of a flute if those holes were (as they ought to be) of equal size, and placed nearly at equal distances. To remedy this, the holes had to be placed at unequal distances, and the errors in tune thus produced were compensated by unequally changing the size of the holes. But this compensation was in the first place not thorough, for the instrument

was still out of tune; it was, in the second place, attended with the serious disadvantage of almost abolishing the whole lower octave of the flute from orchestral resources, since that octave was rendered so weak as to be, one may say, silly in tone; and, in the third place, the equality of power and color was destroyed, some tones sounding veiled and some open, some rich and some thin, and so on. The invention which relieved the flute from all this odium and brought it to the rank of a true solo instrument dates from about the last quarter of a century, and has been claimed both by Captain Gordon and by Bœhm. The latter, at any rate, succeeded in giving his name to it, having manufactured for several years the instrument now universally known as the Bœhm flute. The nature of this invention was briefly as follows. Instead of stopping the holes directly with the balls of the fingers, as before, all the holes were closed with padded keys; and handles were so arranged to these keys—by means of a very ingenious mechanism of hollow shafts which allowed other shafts to pass through and to play inside of them—that any hole on the flute was brought practically in reach of any finger, the fingers pressing upon the handles instead of directly upon the holes. It now became possible to make all the holes much larger than the ball of the finger could cover directly—which had long been a much-desired object, the large holes being found to yield a much more powerful tone—and to place the holes at the precise distances from each other demanded by the mathematical laws of vibration.

The first form of the new instrument received additional improvements from time to time, and the result was the present Bœhm flute—an instrument whose true capacities, especially when used in masses, may be said to be as yet almost unemployable by composers. The lowest octave of the Bœhm flute, when sounded by a player who knows how to avoid the disagreeable cornet-tone which only vulgar ears affect, is of the most precious character, at once soft, suggestive, rich, and passionate. It is wholly different from any tone attainable from any other instrument, and when sounded in unison by eight or ten players is capable of the most delicate and yet striking shades of expression. The failure of orchestral composers to employ it, or, indeed, to learn of it, earlier, is easily accounted for. Flute-soloists have rarely been able to resist the fatal facility of the instru-

ment, and have usually addressed themselves to winning the applause of concert audiences by the execution of those brilliant but utterly trifling and inane variations which constitute the great body of existing solos for the flute. These variations are written mainly for the second and third octaves of the instrument, and the consequence has been an utter lack of cultivation of the lower octave by solo-players, and a necessarily resulting ignorance of its capacity by composers. Not only the solo-players, indeed, have been thus led away from the lower octave; even the hack orchestral players suffered the same fate, for the reason that the old flute had practically no lower octave, and the old composers wrote entirely in the upper two. At present there are rarely more than three flutes even in the largest orchestras; but this writer does not hesitate to record his belief—even at the risk of exciting the eyebrows of many steady-going musicians—that the time is not far distant when the twenty violins of a good orchestra will be balanced by twenty flutes.

And in view of the question which would probably be asked by these objectors, to wit: *Where would you get the players for such a number of flutes?*—I may with propriety at this point diverge for a moment from the direct course, to make a suggestion to my countrywomen in which I feel a fervent interest. With the exception of the double-bass (violin) and the heavier brass,—indeed I am not sure that these exceptions are necessary,—there is no instrument of the orchestra which a woman cannot play successfully. The extent, depth, and variety of musical capability among the women of the United States are continual new sources of astonishment and pleasure to this writer, although his pursuits are not specially of a nature to bring them before his attention. It may be asserted without extravagance that there is no limit to the possible achievements of our countrywomen in this behalf, if their efforts be once turned in the right direction. This direction is, unquestionably, the orchestra. All the world has learned to play the piano. Let our young ladies—always saving, of course, those who have the gift for the special instrument—leave that and address themselves to the violin, the flute, the oboe, the harp, the clarinet, the bassoon, the kettle-drum. It is more than possible that upon some of these instruments the superior daintiness of the female tissue might finally make the woman a more successful player than the man. On the

flute, for instance, a certain combination of delicacy with flexibility in the lips is absolutely necessary to bring fully out that passionate yet velvety tone hereinbefore alluded to; and many male players, of all requisite qualifications so far as manual execution is concerned, will be forever debarred from attaining it by reason of their intractable, rough lips, which will give nothing but a correspondingly intractable, rough tone. The same, in less degree, may be said of the oboe and bassoon. Besides, the qualities required to make a perfect orchestral player are far more often found in women than in men; for these qualities are patience, fervor and fidelity, combined with deftness of hand and quick intuitiveness of soul.

To put the matter in another view: no one at all acquainted with this subject will undervalue the benefits to female health to be brought about by the systematic use of wind-instruments. Out of personal knowledge, the writer pleases himself often with picturing how many consumptive chests, dismal shoulders, and melancholy spines would disappear, how many rosy cheeks would blossom, how many erect forms delight the eyes which mourn over their drooping,—under the stimulus of those long, equable, and generous inspirations and expirations which the execution of every moderately difficult piece on a wind-instrument requires.

But, returning to the main course: it is proper now to speak of the other great division of wind-instruments known as the brass. This usually consists of the trombones, the trumpets and the horns, with perhaps a cornet-a-piston, though this last is not thought by musicians to be worthy of much rank in other than brass bands and military orchestras. The trombone in its older form is probably familiar to most persons as the long brass instrument which the performer elongates and shortens alternately by sliding it out and in. Its tone is gigantic, jubilant and vigorous. The trumpet tone is also familiar for its bold and manly character, or for the startling and crashing breaks which it sometimes makes upon the softer harmonies. The horn is the instrument which curls upon itself in a circular coil, the performer often thrusting his unemployed hand into its large bell to assist in controlling the great difficulties of pure intonation upon this instrument. Its tone is indescribably broad, mellow and noble, and is capable of very great variation in degrees of loudness. Most persons who

have heard Thomas's orchestra will remember the lovely long-drawn *pianissimo* notes of this instrument which introduce the overture to "Oberon," or the far-off ravishment with which it steals upon the enormous chord of violin-tones in Asger Hamerik's "First Norse Suite."

Leaving now the wind-side of the orchestra, let us pass over to "the strings." This term, in the ordinary parlance of musicians, is understood to mean the four classes of the viol-tribe, namely, the violins, the violas, the violoncellos and the contra-basses or double-basses. In its largest application it would of course include the harps, and such rarely used instruments as the guitar and the *viol d'amour*. The violin is too familiar to need comment in so cursory a paper as this. The viola is an instrument almost exactly like the violin, but somewhat larger, and four tones lower in pitch. It has not the brittleness, the crispness, nor the brilliance of the violin; but is distinguished by a melancholy and pathetic tone quite peculiar to itself. Those who have heard the "Italy" of Berlioz will easily recall the viola, which is the hero of the whole piece. It is matter of regret that this noble instrument has now so few cultivators.

The violoncello is a more familiar instrument to most persons than the viola. It is tuned just an octave lower than that instrument. Since the time of Beethoven it has been much cultivated, and passages are now freely written for it which would have made the older players stare and stop for another pinch of snuff. Its powers are quite varied; it is competent for a serenade or a prayer; for suggesting mere lazy tropical sensuousness or manly protests against wrong. Perhaps the most remarkable deliverance intrusted to it by a modern composer occurs in the "Jewish Trilogy" of Hamerik. Here, after a lovely harmonic conception, the whole orchestra ceases, and one violoncello begins a strange monody, which is continued for a long time: a monody as of a prophet standing between the people and the altar and recounting with intense passion the captivities, the escapes, the sins, the covenants, the blessings, in truth, the whole romantic past, of the Jews—the entire effect deriving extraordinary power from the sense of tenacity due to the peculiar sustaining power of this instrument, and from the sense of isolation excited by the lonesomeness of its voice when thus lifted up in the suddenly silent orchestra.

The double-basses are well known to all as the largest of the violin-tribe; and the

harps are also familiar; so that, although both are of great interest to the musician, the points that make them so are too technical for mention in this place, and we may pass on now to a word about the instruments of percussion. Those in common use are the commonly called bass-drum, the snare-drum (employed by ordinary military companies), the cymbals and the kettle-drum. This latter, of which there are always at least two in an orchestra, is like a large, round-bottomed brass pot, the mouth of which is covered with a membrane stretched across. Its pitch is varied by screws which tighten the membrane; the two tones to which the two drums are tuned being usually the tonic and the dominant of the key in which the orchestra is playing. Those who remember the lovely little "Scandinavian Wedding March" by Söderman will recall the adroit employment of the kettle-drum in the opening to intensify the mood of expectation upon which the soft harmonies are presently to fall.

In closing this rapid account of the orchestral constituents, it is proper to mention that several instruments whose employment is more or less unusual have been omitted; such as the bass-flute (sometimes called the alto-flute), which is of quite recent invention, and bears much the same relation to the ordinary flute as that of the viola to the violin; the piccolo, which is a very short small flute set an octave higher than the concert-flute, and which is in nearly every orchestra; the harmonicon, the small harmonium, the *cornio Inglese* (a large cousin of the oboe), the castanets, various sized cymbals, the zither and others. The zither has been made known to many persons by the pretty tinkling air it plays in a dream-piece by Lumbye, which one used to find often recurring in Theodore Thomas's programmes.

As soon as the members of the orchestra have assembled, say for a rehearsal, the first business is to bring all the instruments to the same pitch. For this purpose the oboe, considered to be the least variable instrument, sounds a long and insistent A, with which each player proceeds to make his A (or the corresponding tone if he has a transposing instrument) coincide. The conductor mounts his platform and raps with his baton, holding the latter poised aloft for a moment. Each player must now have his eyes at once upon the conductor and upon the written part before himself—a dual attention which must be maintained steadily throughout the

composition, and which requires more concentration than one is at first inclined to appreciate. With the first down-stroke of the conductor's baton the first bar of the piece commences. Fancy, for example, that you are first flute-player, and that the figures thirty-seven occur over a blank space of the staff on your part. This means that you are not to come in until thirty-seven bars are played by the other instruments; and you are now to carry on a double set of countings in your mind, the one recording the beats of each bar, the other recording the number of bars. You therefore commence, with the conductor's first down beat, to count mentally, keeping a tally of each set of four beats; supposing the piece is in four-four time, that is, that there are four of the conductor's beats to each bar, you say, *one* (two-three-four), *two* (two-three-four), *three* (two-three-four), *four* (two-three-four), *five* (two-three-four), and so on. About the time you have reached *thirty-one* (two-three-four), you will infallibly—if an inexperienced player—fall to wondering whether you did not omit to say *thirty* (two-three-four), and while this inward debate is going on, you have, of course, neglected the *thirty-two* (two-three-four), to remedy which you jump to the thirty-three, but in so doing reflect that you were probably discussing long enough to occupy *two* bars, and ought to have jumped to thirty-four, or, even perhaps, thirty-five—by which time your heart is thumping with anticipation of the conductor's scowl, when you shall presently come in wrong and compel him to stop the whole orchestra in order to commence over—until finally you are in a state of hopeless, inane confusion, and the chances are a thousand to one that you do come in wrong, with all manner of vile discord and resultant trouble. Of course there are many passages which are easier, by reason of one's familiarity with the composition. A certain automatic precision of count comes with long experience.

But if the player's part is by no means the trifling work which many imagine, the conductor's will certainly impress one who becomes acquainted with it for the first time as requiring an amount of mental strain little suspected by those who only see the graceful curves of the baton and the silent figure that moves it. The conductor must read simultaneously all the bars written for each class of the instruments in his orchestra, the notes being written under each other, those for the piccolo and flutes at the

top, those for the double-basses at the bottom, the rest between. But this large collection of notes, which have thus to be instantaneously read, is written not only in different keys, but with different clefs; the horns and clarionets may each be playing in different keys from the other instruments; the tenor trombones will be playing notes written upon a still different system; the violoncellos, notes written upon a still different system; the double-basses and bassoons and bass-trombones and drums, notes written upon yet another system. And this is not half; for while the conductor's eye is reading these notes his ear has to watch over each one of his sixty to a hundred and fifty instruments, and instantly report the least failure of one to play exactly what is written; and this is not nearly all; for besides, the conductor's arm must keep up the unceasing beats of time, and must make the different expression-signs, *i. e.*, the signals for loud or soft, or slower or faster, and the like. Fancy, in other words, that you had a class in elocution of sixty pupils, all of whom simultaneously read aloud to you—some in Greek, some in Hebrew, some in French, some in Latin, some in English—and that the least fault in pronouncing any word of any of these languages, or the least error even in inflection or intonation, must be detected. This is a fair analogy to the labor of the orchestral conductor.

In the judgment of the writer, although the improvements of the orchestra have been very great in modern times, it is yet in its infancy as an adequate exponent of those inward desires of man which find their best solace in music. No prudent person acquainted with the facts will now dare to set limits to the future expressive powers of this new and manifold voice which man has found. The physics of music have made such enormous advances under the scientific labors of Helmholtz, Alfred M. Mayer and others, that the art cannot but receive additional aid through the facts thus discovered, and one cannot help looking to see new instruments before long which will indefinitely increase the resources of the orchestra of the future. Many reasons seem to justify the belief that the home of the orchestra is to be in this country: meantime, one can frame no fairer wish for one's countrymen than that they may quickly come to know the wise expansions and large tolerances and heavenly satisfactions which stream into the soul of him that hath ears to hear, out of the orchestra of the present.

PETER THE GREAT. III.*

BY EUGENE SCHUYLER.



CHURCH OF ST. BASIL, MOSCOW. DRAWN BY F. LATHROP FROM A PHOTOGRAPH.

CHAPTER X.

IVÁN ELECTED TSAR TOGETHER WITH PETER.
SOPHIA APPOINTED REGENT. PACIF-
ICATION OF THE STRELTSI.

WHEN once the fury of a mob has been excited by the sight of blood, it will commit deeds which at first all would have looked on with abhorrence; and it is rare that a riot, beginning from whatever cause,—as we, in America, unfortunately know,—does not end in conflagration, pillage, and robbery. Singularly enough, it was not so

with the riot of the Streltsi. The soldiery satisfied their desire for revenge by killing the men whom they had had cause to dislike in their campaigns, or whom they believed to be injurious to the State. They pillaged the Department of Serfage, in order to set free the peasants and gain themselves supporters, but they carefully abstained from the indiscriminate pillage of private houses. That they entered drinking-houses and ate and drank without payment was what might naturally be expected under the circumstances. Rosenbusch and all the eye-witnesses explicitly state that the Streltsi

gave strict orders that no pillage should be allowed, and kept watch that no persons pretending to be Streltsi should attack and rob the people, either in the town or in the environs. About forty persons, some Streltsi, and some poor peasants, were executed for having stolen goods in their possession, though the value of some articles did not exceed four kopeks (about three cents).

Not feeling yet satisfied with the indemnity for the losses of pay and subsistence, caused by the cheating and robbery of their officers, the Streltsi, as soon as the murders were over, and before even the bodies were buried, petitioned the Government to grant them a sum of two hundred and forty thousand rubles as back pay, and also to confiscate the property of those officers and magnates who had been killed in the riot, and distribute it among them.

Frightened as the inmates of the palace were, they were unable to admit demands like these, and they finally succeeded, by a liberal supply of drink, in compromising at the rate of ten rubles to each man, and by putting up the personal property of those killed to auction, when the Streltsi were enabled to buy what was for sale without much competition. The money to pay the Streltsi had to be raised by a general tax, and for the necessities of the moment much of the silver plate of the palace was melted down and coined into money. Van Keller writes:—"The new Government is trying to content the Streltsi and the soldiers, but a great amount of money is necessary, and additional taxes and contributions are put upon everybody. This ought to be a good

ward, and had endeavored to pacify the rioters. This was but natural. She surpassed all the other princesses in natural abilities as well as in strength of mind and character. She had received an education more masculine than feminine, for she had shared the studies of her brother Theodore. She had been much with her brother during the last months of his life, had been at his bedside during his illness, and had gradually and involuntarily in this way come to be acquainted with affairs of state, and to be the medium by which the orders of the Tsar had been transmitted. It was in Theodore's sick-chamber that she first knew Prince Basil Galítsyn, and it was there that she began to judge of the characters of officials and statesmen. She alone preserved her presence of mind throughout the riots, and it was but natural that all should turn to her for advice or orders. New officials stepped into the places and began to perform the duties of those who had been killed, without at first any rightful authority, although they were afterward confirmed in their offices. In this way Prince Basil Galítsyn took charge of the Department of Foreign Affairs, Prince Havánsky of the department of the Streltsi, and Prince Iván Miloslávsky of several other departments.

The feeling that there was a certain illegality in the election of Peter, to the exclusion of his elder brother, Iván, was strong among the Streltsi, and was doubtless greatly increased by the partisans of the Miloslávskys, whose own interests would have been advanced by the accession of Iván. They did not, however, demand the actual depo-

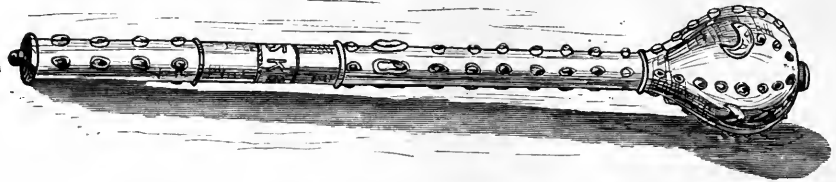

THE BATON OF PRINCE GALITSYN. (DRAWN BY MAURICE HOWARD.)

lesson to those vile gain-seekers, and extortioners of gifts and presents."

A new Government had indeed been formed by circumstances and of itself, without apparently any orders from Peter or his mother, but called out by the necessities of the moment. We see by the relation of Rosenbusch, the Danish Resident, that in the latter part of the riot, the Princess Sophia had been brought prominently for-

sition of Peter, for he was the son of a Tsar, and had himself been proclaimed Tsar by the Patriarch. They proposed to make Iván Tsar also. On the third of June, Prince Havánsky reported to the Princesses that the Streltsi had sent a deputation to say that they, and all classes of the Muscovite State, desired that both brothers, Peter and Iván, should reign together, threatening, if this were refused, to come again to the

Krémlin with their arms, and prepared for attack. The chief nobles and officials who could be found were hastily called together, but as they were unwilling to take the responsibility of deciding the matter, a special council was summoned in the palace, to which were invited not only the officials, but also the Patriarch, the archbishops and the leading clergy, and deputies of the Muscovite state. Such deputies happened to be in Moscow at that time, having been called there for another purpose by Theodore, shortly before his death, for the purpose of equalizing taxation, but whether these men took part in the council, or merely deputies from the city of Moscow, is a matter of question.

The threat that the Streltsi might make another attack brought nearly all the nobles to the Assembly, and the proposition of a double reign was urged as in the highest degree advantageous, for it was maintained that when one Tsar went to the wars, the other could stay at home to govern the country. Examples in history were not wanting, and members of the Council cited in the discussions the cases of Pharaoh and Joseph, Arcadius and Honorius, Basil and Constantine. Under the threat of the Streltsi, discussion was hardly free, and the partisans of Peter had suffered too much to make strong opposition. It was, therefore, soon decided that both the brothers should reign together. The great bell was rung, prayers were said in the Cathedral of the Assumption, and solemn petitions were put up for the long life of the most Orthodox Tsars, Iván Alexévitch and Peter Alexévitch. It was with difficulty that Iván could be induced by his sisters to take even a nominal part in the Government. He alleged the defects of his sight and speech, and said that he cared more for a quiet and peaceable life, than for the world's government, but he would assist his younger brother in council and deed. By the terms of the proclamation in the Cathedral, the name of Iván was mentioned first, as the elder brother, and he was in this way given precedence over Peter; but in consequence of a row into which the Streltsi had got with partisans of Peter, among the populace, who laughed at the idea of Iván's actually being Tsar, the leaders of the Streltsi felt it necessary to express more clearly the relations between the brothers, and a deputation came to the palace begging that Iván should be the first Tsar, and Peter the second, and obedient to his elder brother. Two days

later, on the 5th of June, there came another deputation of Streltsi, demanding that on account of the youth and inexperience of both the Tsars, the Government should be carried on by the Princess Sophia, as Regent.



THE PRINCESS SOPHIA, SISTER OF PETER.

When this proposition was discussed in the Council, an historical example was again adduced; for, had not Pulcheria been regent during the youth of her brother, Theodosius? Sophia was, therefore, asked to take upon herself the reins of government. She at first refused; but, on being sufficiently pressed, consented. A decree, announcing the joint accession of Iván and Peter, and the regency of Sophia during their infancy, was issued the same day and sent to the different provinces of the Empire.

In the meantime, in pursuance of the work of conciliation, and in order to acquire a better influence over them, the Government had given to the Streltsi the honorary appellation of the "Palace Guard." They had been complimented for their loyalty and fidelity by Sophia herself, and had been feasted in the courts and corridors of the palace at the rate of two regiments a day. The Princess Sophia herself had even handed round cups of *vodka* to the men. But in spite of the feasts and honors given to them, the Streltsi did not feel quite easy in conscience. Although they had made a change in the Government, yet the Government was carried on by the same sort of people as before. Certain boyárs had been killed, but their places had been taken by



SOPHIA FEASTING THE STRELTSI. DRAWN BY N. DMITRIEFF.

others in all respects like them. The enthusiasm with which the movement had started gradually died out. The Streltsi recognized their own incapability of governing; they despaired of any permanent good from their efforts. They knew that they had acted in a manner contrary to discipline and law, that they were in fact rebels. They had offended the boyár class, not only by their riot and their murders, but by their action in favor of the serfs; and now—for discipline had in the end proved too strong for them—they had placed themselves in a position of antagonism to the serfs. On the very day, when, in consequence of the action of the Streltsi, Sophia was proclaimed Regent, many of the serfs had united in a petition for their freedom, complaining of the measures which the boyárs, their late masters, had taken against them. This petition was rejected with contempt by the Government, and the Streltsi were ordered to hunt out and catch the runaway serfs, torture, imprison and punish them, and restore them to their masters. More than this, the Streltsi were induced to declare that they had no sympathy with the serfs, and would not assist them against their masters. About Pentecost time, there were numerous conflicts between the Streltsi and the fugitive serfs. There were night alarms,

and the bells of the churches were rung even in the German suburb. As many of the serfs who resisted were cut down mercilessly by the Streltsi, the others became frightened, and they began gradually to return to their masters.

While the Streltsi felt safe in Moscow, where the population, if not sympathetic to them, was at least afraid of them, they knew that it would be comparatively easy for the boyárs to raise an army of their adherents in the more distant provinces, lead them to Moscow and obtain the upper hand. To secure themselves as much as possible against such an event, they presented to the Government, through Alexis Yúdin, one of their leaders, and the right hand of Prince Havánsky, a petition, and, at the same time, a justification, purporting to be not only from the Streltsi themselves, but also from all the burghers of Moscow. In this they attempted to explain and defend their conduct during the riots. They asserted that they had taken up arms on the 25th of May to protect the family of the Tsar from great harm, that they had punished Prince Yúry and Prince Michael Dolgorúky, for insults which they had long given to them, and for the harm which they had wrought to them in depriving them of their pay, and in being greatly unjust to them. They had

killed Lárion Ivánof, because he had joined with the Dolgorúkys, and had threatened to hang them all. They had killed Prince Romadonófsky, believing him to be guilty of treachery in delivering up Tchígírin to the Turks and the Tartars. They had killed Yazýkof, because he had taken the side of their colonels, and had put great assessments upon them, and had taken bribes. They had killed the boyár Matvéief and Dr. Daniel Von Gaden, because they had poisoned the Tsar Theodore with herbs, and had wished to poison the present Tsar, which Dr. Daniel had confessed when tortured. They had killed Iván and Athánásius Narýshkin, because they had tried on the Imperial crown, and had plotted all sorts of evil against the Tsar Iván, just as they had before done against the Tsar Theodore Alexéivitch, for which they had been exiled. They therefore asked permission to erect on the Red Place a column, on which should be inscribed the names of these evil-doers, and the crimes for which they were killed; and desired that a document, with red seals, should be given to all the regiments of the Streltsi, to the soldiers, and to all the people of the suburbs, that none of the boyárs or councillors should revile them, or kill them as rioters and traitors, and that no one should be sent without reason into exile, or beaten or punished because they had served with fidelity. The Government consented; it dared not refuse. Tsykler and Ózerof were ordered to carry out the demands of the Streltsi, and a monument, with the proposed inscription, was erected on the Red Place.

The erection of this monument does not seem to have impressed contemporaries as it does us. The Dutch Resident, in speaking of it, says: "A high pyramid is to be erected giving the faults of those who were killed and the justification of the massacres. This is a good lesson and warning to the bribe-takers who have caused so much disorder."

Order seemed now to be restored; thanks were solemnly given in the churches for the end of the riots; and the Tsars made a state pilgrimage to one of the neighboring convents.

CHAPTER XI.

THE DISSIDENTS DEMAND DISCUSSION. CORONATION OF THE TSARS, 1682.

It has already been remarked that the siege and capture of the Solovétsky Monastery and the rigorous persecution of the

Dissenters increased the dissatisfaction of the people without having great effect in putting down dissent. It produced a rupture between all the old-believers and the Government, which, from its using force to put down the true religion, made itself unlawful in their eyes. The Dissenters played a great part in the insurrection of Stenka Rázin, and in all the popular movements of the time. The administrative centralization of Russia had at first only touched the higher ranks of life, both lay and clerical, but gradually it began to subordinate to itself, the common people, the villagers, and the parochial clergy. In the concealed, but no less real, struggle against centralization the autocracy obtained everywhere the preponderance, but discontent remained in the lower classes. As far as concerned their religious ideas, this discontent and the dislike of the new dogmas and rites were increased by the arrogant tone which the superior clergy took toward the village priests and toward the mass of the common people, a feeling frequently expressed in the writings of the Dissenters. It was increased, too, by the dislike the Russians felt to the foreigners who had settled in Russia, and to the foreign influences which were increasing and growing stronger—influences not only of the Germans, both Protestant and Catholic, who had entered the army and whose families lived in the German suburb of Moscow, but also those Polish influences which came from the schools of Kíef, and were increased and spread by the monks and other clergy, who had received their education in Poland and Kíef. There was even a prejudice against the Greek clergy from Constantinople, who were thought to be less tainted with Latinism and Romish doctrines, but were accused of being more eager to amass their rubles than to keep the purity of the faith. The common people, in their dislike of novelty, hated the Polish influences, making themselves felt at court and in the administration; and the Dissenters, like the Streltsi, laid all the blame on the boyárs. They thought as Kópytof, a Dissenter exiled to the furthest part of Siberia, said: "All in Moscow is according to the will of the boyárs. What the boyárs wish, that they do."

Such convictions led the Dissenters to think that the apparent triumph of the popular principles which had been proclaimed in the riot of the Streltsi would be advantageous to the cause of what they considered true religion; that there would be a revolu-

tion in the habits and maxims of the Government, and a return to old Russian ideas and practices in religion as well as in politics.

Many of the Streltsi were Dissenters, and in some regiments this belief predominated and it was known that the Prince Havánsky, their new chief, was a great adherent of the old believers, and had for a long time protected one of their leaders, the Protopope Habbakuk, or Avvákum. The third day after the end of the riot, in the Krémelin, the Streltsi of the Titóf Regiment, which contained a particularly large number of Dissenters, began to consider what measure they might take for restoring the old belief. They resolved to write a petition in the name of their comrades and of the inhabitants of the suburbs, requesting the Government to "restore the use of the old books which were printed in the time of the orthodox princes and Tsars, and the five Russian Patriarchs, and to cease loving the Latin-Romish faith, devised according to man's will, but not according to God's." After much searching they found a man to write that petition—a monk named Sergius, greatly respected, "a firm adamant skilled in learning." When the petition had been drawn up and was read in the assembly of the Streltsi, they wept with astonishment to see how many fearful heresies had crept into the new books. They had not the ability to go into details, but were firmly convinced that the true faith was being persecuted. "Don't give us up, O brethren, to be per-

secuted as before. Do not allow us to be tortured and burned," cried Sergius to the assembly.

"O Father, we are ready to shed our blood for the old piety," answered a lieutenant-colonel.

All promised with one voice to stand up for the orthodox faith, if necessary, even to death. One of the demands in this petition was, that a public discussion on the disputed points of the faith should be held either on the Red Place or in the square between the Cathedrals. This discussion the Dissenters insisted upon because, firmly believing the truth of their doctrines, they felt sure of an easy victory and were convinced that they could readily get over to their side all the people present. Prince Havánsky, when informed by the Streltsi that the petition was ready, was much pleased, and asked whether there was any one who would be able to enforce the arguments of the Dissenting side. On being informed that there was an old monk "skillful in disputations and firm in the faith," Havánsky requested them to come to his house, and fixed a time for the interview.

The dissenters were very warmly received by Havánsky's servants, but were obliged to wait three hours until the Prince could dismiss some guests who were with him. At last he came in, and, seeing the monk about whom he had heard so much, bowed to the ground and asked: "For what hast thou come to me, reverend father?" Sergius replied that he had brought a petition,



ORTHODOX SIGN OF THE CROSS, IN BENEDICTION.



ORTHODOX SIGN OF THE CROSS, IN PRAYER.



DISSENTING SIGN OF THE CROSS.

with an account of the heresies in the new books. "I myself am a sinner," replied Havánsky. "I much wish that all should, as of old, worship in the holy church unan- imously and without difference; but, al- though I am a sinner, I undoubtedly keep to the old piety. I read the old books, and I sign myself with the sign of the cross, made by two fingers." Havánsky then re- cited the creed, with the addition, thought indispensable by the Dissenters, of "and in the real life-giving Holy Ghost," and con- tinued: "Thus I believe, and thus I teach, and I pray God to be merciful to the Chris- tian people, and not to allow Christian lands to be utterly ruined by the present

them." Other Dissenters then suggested to Havánsky the famous Nikíta, of Súzdal, as a fit man for the time—a priest who, after hav- ing been a leading Dissenter, had formally re- canted, but had now gone back again to Dissent. His adversaries had given him the nick-name of "Bladder-head." Hav- ánsky was delighted with the suggestion, for he had a high opinion of Nikíta's abili- ties, and thought that none of the orthodox could successfully oppose him in dispute. "I am glad to help you, brethren," he said, "and do not at all imagine that, as of old, you will be punished, or hanged, or cut to pieces, or burned."

The Dissenters then demanded a public



CATHEDRAL OF THE ASSUMPTION, MOSCOW, WHERE THE TSARS WERE CROWNED. DRAWN BY R. SAYRE FROM A PHOTOGRAPH.

new Níkonian belief." According to cus- tom, he ended his discourse with texts. The petition was then read, but Havánsky did not receive such a favorable impression of the "firm adamant" as his supporters desired. "I see, O father," he said, "that you are a peaceful and quiet monk, not talk- ative, not eloquent. You are not the man for such a great act. We must set against them a man of many words, who can reply to

discussion at the Lobjnóë Place in the pres- ence of the Tsars and of all of the people, and, if not there, at least in the Krém- lin at the Red Staircase, and insisted that this dis- cussion should take place without fail on the following Friday, the 3d of July; for Friday, by old custom, had been specially set apart for religious assemblies. Haván- sky replied that Friday would be impossi- ble, because Sunday, the 5th, was appointed

for the coronation of the Tsars. This was exactly what the Dissenters wished for, as they said: "We desire that our lords should be crowned in the true orthodox faith, and not according to the Romish-Latin belief." Havánsky assured them that the two Tsars should be crowned according to the old

the new faith." Havánsky could not reply to this, and said: "Well, be it as you will. Let the assembly be for Friday." The Dissenters departed contented.

At early dawn on Friday, the 3d of July, the deputies of the Streltsi came to Havánsky and inquired at what time he desired the



INTERIOR OF THE CATHEDRAL OF THE ASSUMPTION.

rites and usages existing since the time of Iván Vasilievitch. But the Dissenters wished not to have the old rites alone. They said: "The Tsars will commune during the Liturgy, and the Patriarch will officiate according to the new rite, and at the coronation he will urge the Tsars to defend

fathers to come to the conference. Havánsky replied, "In two hours." Two hours later the fathers appeared in the Krémlin in a triumphal procession. Nikíta carried the holy cross, made according to the old rite, with three bars. Sergius, the writer of the petition, bore the Gospels, and a monk, Sa-

vatus, who had just arrived from the Volokolámsky Hermitages, carried a picture of the "Last Judgment." Crowds of people, surprised by this unusual procession, collected in the streets, and asked one another in whispers what all this meant; and as they followed the procession, recited in low tones, "Lord, have mercy on us! Lord, have mercy on us!"

On their arrival at the Krémelin, the Dissenters' procession stopped at the Red Staircase, and sent word of their arrival to Prince Havánsky. They were taken, according to custom, into the "answering hall" where Havánsky put on an air of ignorance, and went through the usual formula of asking the purpose of their coming. At the same time he made obeisance to the Gospel and to the cross. Nikíta replied: "We have to come to petition with regard to the old orthodox faith, that the Patriarch and the archbishops may be ordered to officiate according to the old rite. If the Patriarch refuse to do this, let him answer in what respect the old books are bad, and why he has persecuted the adherents of the old rite." He promised, for himself and his adherents, to show many heresies in the new books. Havánsky replied to Nikíta, as he had formerly done to Sergius: "I myself am a sinner, but I believe according to the old books." He took the petition and went up to the chamber of the Tsars. Returning in a little time, he said that, at the request of the Patriarch, the Tsars had put off the discussion of their petition until Wednesday, as it was an important matter, which needed much time; that the books must be compared; and he advised them to come on Wednesday, after dinner. Nikíta, however, did not forget that the coronation was arranged for Sunday, and immediately asked: "How will the Tsars be crowned?" "According to the old rite," answered Havánsky. Nikíta insisted that the Patriarch should officiate at the liturgy, as of old, with seven wafers, and that the cross upon these wafers should be the real and true cross, and not a Latin one. To get rid of him, Havánsky answered: "Bring me some wafers baked with the impress of the old cross. I myself will take them to the Patriarch, and order him to serve according to the old rite, and you, Father Nikíta, go home."

Next day, two other refugee Dissenters arrived—Father Dorotheús and Father Gabriel. There was great joy among the Dissenters, who felt sure of a speedy triumph. Nikíta requested a certain widow of his ac-

quaintance to prepare the wafers in the old style.

Although Nikíta started out early on Sunday morning with his wafers carefully packed in a wallet, when he arrived at the



DOUBLE THRONE USED AT PETER'S CORONATION.
DRAWN BY MAURICE HOWARD.

Krémelin, he found the crowd so great in the square about the Cathedral that it was perfectly impossible for him to reach even the barriers. Much against his will, he was obliged to return, and coming sadly into the assembly of the faithful, placed the wafers on the table, saying: "Pardon me, O holy fathers! The people would not allow me to approach the Cathedral, and I have brought back the wafers." They were, therefore, after service, distributed among the faithful at benediction.

Meanwhile the coronation had taken place. On the evening of the 4th of July, 1682, there was a grand vesper service in all the churches, and especially in the Cathedral of the Assumption, where it was celebrated by the Patriarch Kir Joachim, attended by all the superior clergy. During the night a square platform, raised on twelve steps, was erected in the middle of the Cathedral, immediately under the dome,

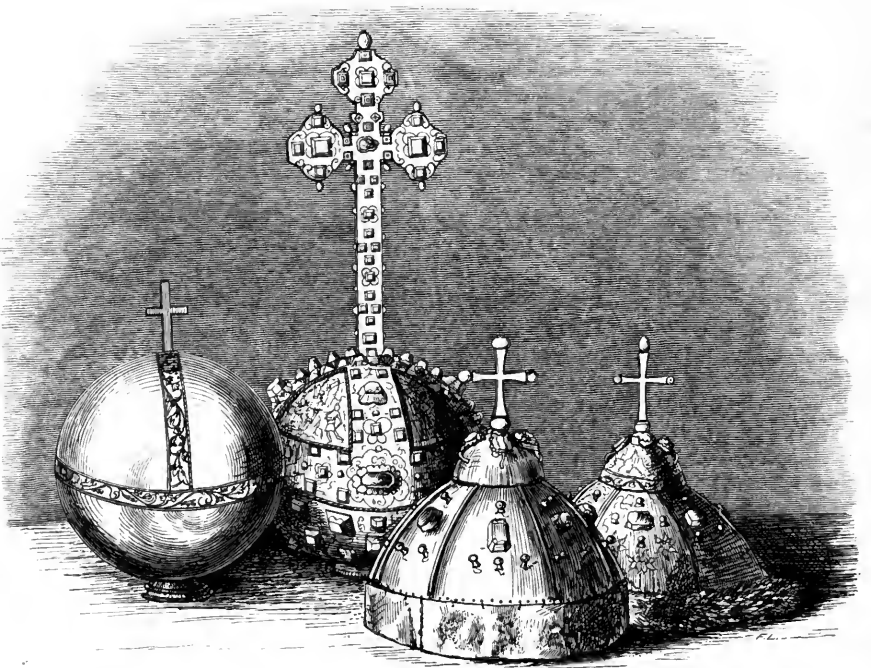

ORB OF PETER.

ORB OF MONOMACHUS.

CROWN OF PETER.

CROWN OF MONOMACHUS.

DRAWN BY MAURICE HOWARD.

and covered with crimson cloth. From this platform to the chancel, the pavement was spread with red cloth, on which two strips of scarlet velvet were laid for the Tsars, and a strip of blue velvet for the Patriarch. On each side were raised seats for the clergy, covered with Persian carpets and cloth-of-gold. On the center platform a double throne was erected. There had not been time to make entirely fresh regalia for the double coronation, and the silvered gilt throne of handsome workmanship made for the Tsar Alexis was divided by a bar in the middle, so that it could be used by the two boys. Behind, a seat was placed, so that the monitor of Peter, through the hole in the back, could whisper to

less expense, for the use of Peter. The old historic ones, with which all the Tsars had been 'crowned, were reserved for Iván. This was the last time they were ever used. The successors of Peter were Emperors, not Tsars; and the crown and pectoral cross of Monomachus, the visible symbols of the relations of the Muscovite Tsars to the emperors of Constantinople, are now mere curiosities in the Imperial treasury at Moscow. On the left side of this throne was a third throne for the Patriarch, the spiritual emperor. This, too, was used for the last time. The power of the clergy was to be diminished, and the rule of the Patriarch to be broken.

In the chancel were placed six reading-



THE GREAT SCEPTER. DRAWN BY MAURICE HOWARD.

him the necessary responses. The crown, scepter, and globe, originally presents from Constantine Monomachus, Emperor of the East, to the Grand Duke Vladímir of Kief, had been imitated in smaller size, and at

desks, two lower than the rest, covered with satin embroidered with jewels, on which were to be placed the crown and scepter and the pectoral cross of Monomachus, containing a relic of the true cross.

At the first dawn of day, on the 6th of July, the bells began to ring joyfully and there was a great procession of the clergy from all the churches. At 5 o'clock the two boy Tsars went to the Palace Chapel for Matins, and then in procession to the banqueting-hall. Here, in honor of the day, they promoted to the rank of boyár Prince Andréi Havánsky, Michael Plestchéief, and Matthew Miloslávsky. Lárion Miloslávsky and Zméief were made okólnitchi, and Hítrovo and Pushétchnikof appointed privy-councillors. The Tsars wore long robes of cloth-of-gold covered with lace and fringes, broad sleeves and caps set with precious stones. Not only were their robes cut from the same piece, but the candles they held were of the same length that there might be no inequality. Select boyárs were then sent to the treasury to fetch the cross, the crown, the scepters and the other regalia, which were brought in by priests, and then carried to the Cathedral of the Assumption, where they were received by the Patriarch and the superior clergy on gold dishes, and placed on the lecterns prepared for them. On entering the banqueting-hall the boyárs informed the Tsars that all was ready, and then a long procession—beginning with the inferior officials, rising to the highest boyárs, then to the Tsars, and gradually diminishing again to the petty officials and nobles—went slowly down the Red Staircase, from the banqueting-hall to the Cathedral of the Assumption, over a path made on the pavement by crimson cloth, which was sprinkled by priests with holy water, through the dense masses of the populace which filled the whole square. At the entrance of the Cathedral, the Tsars were met by the Patriarch, who wished them long life and held them the cross to kiss. After kissing the great pictures on the altar-screen, especially the Virgin painted by St. Luke, the Tsars took their places on the platform. Standing here in this old cathedral, crowded with their subjects, the gilded walls and pillars of which, lighted up by flickering candles, displayed the rude pictures of saints and martyrs; under the great central dome, from which looked down the gigantic image of our Savior, with hands upraised in the act of blessing, the Tsars, after reciting the story of their accession to the throne, demanded of the Patriarch the rite of consecration and coronation. The Patriarch in reply, asked to what faith they belonged. They answered: "To the holy orthodox Russian faith," and set forth in a long

speech, the good which they expected to do to their people. Then, after hymns and prayers, and swinging of censers, the Patriarch placed on their heads the crown of Monomachus, threw over their shoulders the coronation vestments, placed on their breasts the pectoral cross, gave the scepters and globes into their hands, and then, when all had again taken their seats, ascended the pulpit and preached a sermon upon the mutual duties of Tsar and people. Then followed the mass, during which the Tsars, in sign of their being priests as well as kings, went within the chancel behind the altar-screen, and administered to themselves the Eucharist with their own hands. When the service was over, the Tsars again kissed the true cross, the relics and the holy pictures, and with the nobles went in procession to the Cathedral of the Archangel Michael, where they paid reverence to the tombs of



CATHEDRAL OF ST. MICHAEL THE ARCHANGEL, MOSCOW.
DRAWN BY R. SAYRE FROM A PHOTOGRAPH.

their ancestors, the Tsars who are buried there, and especially to that of the Tsar-évitch Dimítiri, who had already been canonized, and of whose death recent events must have often made them think. From there they went to the Cathedral of the Annunciation, then to the banqueting-hall of the palace, where they received congratulations. Two days later occurred the great official banquet of the coronation.

CHAPTER XII.

THE RIOTOUS DISPUTATION OF THE DISSIDENTS,
AND ITS ENDING.

A WEEK was passed in waiting, though it was made useful by meetings for prayer and public preaching in the remoter quarters of Moscow. On the 13th of July, the Dissenters and the delegates of the Streltsi resolved again to demand the solemn dispute which had been promised them by Havánsky, and for that purpose went to the Krémelin. Havánsky, who had heard that the Streltsi were not entirely agreed upon the matter, asked, in the name of the Tsar, if all the regiments were united in their desire to restore the old belief. The delegates replied that all the regiments and the people of the suburbs would joyfully stand up for the old orthodox Christian faith. Havánsky repeated the question twice, and again the delegates replied: "We are ready not only to rise, but even to die for the faith of Christ." When Havánsky had reported this answer to the Princess Sophia, he went with the delegates to the Patriarch, and after a lively exchange of words and arguments the Patriarch agreed to a solemn disputation on Wednesday, the 15th of July, the next day but one. This having been decided upon, Havánsky and the delegates advanced to the Patriarch and received his blessing; but Paul, one of the leading Dissenters, declined it unless the Patriarch should bless him according to the old rite. This was refused, and Paul went away without the benediction. Havánsky kissed him on the forehead, and said: "I did not really know you, my dear fellow, until now."

Meanwhile the dissenters lost no time. Their preachers went everywhere throughout the town, preaching in the streets, and calling upon the inhabitants to rise for the old orthodox faith. On Wednesday, the 15th of July, Nikíta, after performing service with the Titóf regiment, went with his adherents to the Krémelin, accompanied, as before, by delegates of the Streltsi, and a crowd of people. They drew near the Cathedral of St. Michael the Archangel, close to the Red Staircase, set up their reading-desks, placed upon them old images and books, and lighted their candles. Nikíta stood upon a bench, and began in a loud voice to preach to the people.

The Patriarch at this time was celebrating the liturgy and praying for the appeasement

of the riot. As soon as he learned that the crowd had arrived, he sent priests out to exhort them, and distributed among them printed copies of the recantation, which Nikíta had signed in the time of the Tsar Alexis, and by which he had promised in future to abstain from the errors of Dissent. The Streltsi tore up the copies of the petition, seized the priest and handed him over to the Dissenters, whom they had taken under their protection. The Dissenters went on reading the pamphlets written by the Solovétsky monks about the true method of signing the cross, while all around listened with silence and respect, and many wept.

As soon as the service in the Cathedral was ended, the crowd demanded that the Patriarch should come out into the Place. Havánsky insisted at the palace that the Patriarch should be ordered to go out to quiet the people, but that neither the Princess Sophia nor the Tsaritsas should be present at the assembly, as the crowd was too great, and they might be in danger. Sophia decided that the conference should take place in the banqueting-hall, and, in spite of the efforts of Havánsky, insisted upon being present. The Tsaritsa Natalia, and one of the aunts of Sophia, agreed also to be present.

The Patriarch was then advised, as a matter of precaution, to come to the palace by the back staircase, with all the archbishops; but to send the old parchment manuscripts and books from the Patriarchal Sacristy by the priests, up the Red Staircase. The crowd expressed great satisfaction as they saw the books being carried past them to the palace. "Now," they said, "the truth will evidently be made clear." The leaders of the Dissenters for a long time refused the invitation to enter the banqueting hall, saying that they would not be safe, and that they would be in danger of being arrested. Havánsky gave them his solemn assurance that no harm should attend them. Still there was hesitation, until Nikíta told Prince Havánsky that he believed him, and then they agreed to go. Once again Havánsky tried to frighten Sophia, and induce her not to be present in the banqueting-hall. The Patriarch steadfastly refused to go there without her, and Sophia said decisively that she would not abandon the Patriarch. Havánsky then sent word to the Dissenters to enter.

The Dissenters started with their crosses, their gospels, their images, desks and candles, chanting hymns as they went.

In an ante-room they met the priests, who were carrying the ancient books and parchments into the banqueting-hall; there was much scuffling and pushing, and some blows were exchanged. Havánsky, hearing the disturbance, angrily turned out the priests, who had come there by orders of the Patriarch, and admitted only the Dissenters and as many of the crowd as could force their way into the hall with them.

The Dissenters had come to declaim

windows below the ceiling which were made for such purposes.

Bowing to the Princess, the Dissenters stationed their reading-desks before the throne, arranged their images and books, and lighted their candles, exactly as they had done in the open air. Sophia turned to them, with half-concealed anger, and asked:

"Why have you come so boldly into the Tsar's palace, as if to infidels and



THE DISPUTATION BEFORE SOPHIA. DRAWN BY N. DMITRIEFF.

against what was new, and to insist upon the re-establishment of old and time-honored rites and practices. Yet, strangely enough, they accepted, without comment, a novelty far greater than that which they had come to inveigh against, for, on the throne not the Tsar, but the Princess Sophia sat, together with her aunt, Tatiana; and in arm-chairs below were the Tsaritsa Natalia and the Princess Mary. The young Tsars were not present, but in all probability looked on the scene from one of the small

heathen, and what do you want of us? How dare you go about the town and the Krémelin preaching your Dissenting heresy, and exciting the common people?"

"We have come to the Tsars, our Lords," said Nikíta, "to petition about the amendment of the orthodox faith, that divine service may be performed according to the old rites, as was ordered in the time of the Tsar Michael Feódorovitch, and of the Patriarch Philarét."

The Patriarch then turned to them, and

repeated what he had already said to them in his own house :

"It is not for you common people to manage church matters. You ought to be advised by the Holy Church, and by the archbishops, whose duty it is to judge of these things. Our faith is that of the old orthodoxy of the Greek rite; we have only corrected the service-books grammatically from Greek manuscripts, parchments, and books."

"We have not come to talk about grammar," answered Nikíta, "but about the dogmas of the church;" and he boldly began to enumerate his arguments, beginning with the question, "why the archbishop should carry his cross in his left hand, and his candle in his right hand."

Athanásius, the archbishop of Holmogóry, began to explain, when Nikíta advanced, as if to seize him by the collar, saying :

"Why dost thou, who art the foot, place thyself above the head? I am not talking to thee, but to the Patriarch."

"Do you see what Nikíta is doing?" cried out Sophia, turning to those about her. "He wants to fight, even before us. If we were not here, he would certainly have killed the Patriarch long ago."

"No, lady, I did not beat him; I only waved him off, so that he should not speak before the Patriarch."

"How do you, Nikíta, dare to talk to the Patriarch?" Sophia continued. "Is it not enough for you to be in the presence of our 'piercing eyes'?' You made a recantation to our father of blessed memory, and to the most holy Patriarch, with a great curse upon yourself, never to petition against the faith, and now again you have set about the same business."

"I do not deny," replied Nikíta, "that I did sign a recantation through the power of the sword, but to the petition, which I gave to the assembly, not one of the archbishops dared answer. Simeon Polótsky aimed his book—'The Staff'—at me; but in that book he did not touch a fifth of what I said. If you will allow me to read the answer against that 'Staff,' I will refute it."

"Hold your tongue," said the Princess, angrily. "You have no business to talk with us and be in our presence;" and she ordered the petition to be read.

When they came to the place where it was stated that the heretical monk, Arsénius, together with Nikon, wrongly influenced the mind of the Tsar Alexis Michailovitch, and that since that time true piety had ceased in Russia, Sophia could no longer contain her-

self, angrily interrupted the reading, and, starting from her throne, said :

"We will no longer endure such talk. If Arsénius and the Patriarch Nikon were heretics, then our father and brother were also heretics, and it is plain, then, that the Tsars are not Tsars, that the Patriarch is not the Patriarch, and that the archbishops are not archbishops. We will no longer hear such outrageous things. Sooner than that, we will leave the Empire."

With these words she left her place and moved away from the throne. The boyárs and the delegates of the Streltsi immediately begged her to return to her place, and swore that they were ready to lay down their lives for the Imperial house; but there were some voices that called out :

"It has long been time, lady, for you to go to a monastery. You have troubled the Empire quite enough. Tsars will be good enough for us. Without you the place will not be empty."

A cry such as this could scarcely weaken the impression made upon the Streltsi delegates by the words of Sophia.

"It is all because the people are afraid of you," said the princess to them. "It was from hope in you that these riotous Dissenters have come hither so boldly. What are you thinking about? Is it right for such brutes to come to us with rioting, and cry at us, and give us discomfort? Are you, who were true servants of our grandfather, our father, and our brother, really joined to the Dissenters? You call yourselves our true servants. Why, then, do you allow such misconduct? If we are going to be in such slavery that we and the Tsars can no longer live here, we will go to another town, and we will tell to the people what we have suffered."

Nothing could affect the Streltsi more than the threat that the Tsars would leave Moscow, while they well enough knew that the riots and murders of May had excited the feelings of the boyárs and upper classes, they also knew that the common people obeyed them only because they feared them; and if the Tsars should leave Moscow and collect an army in the country, there would be no hope for them. The delegates therefore answered :

"We are ready to serve our lords with truth and fidelity, and to lay down our lives for you and the orthodox faith, and to act according to your commands."

Sophia then returned to her place and the reading of the petition continued. She could not always restrain herself from interrupting and arguing with the Dissenting



THE DISSIDENTS EXHORTING THE PEOPLE FROM THE RED STAIRCASE. DRAWN BY N. DMITRIEFF.

monks. After the petition had been finished the Patriarch took in one hand the gospel written by the Metropolitan Alexis, and in the other the decretal of the Patriarch Jeremiah, with the creed, just as it was written in the newly corrected books. "Here are the old books," said the Patriarch. "We follow them fully." But the strongest impression of all was made by one priest who advanced with a book printed in the time of the Patriarch Philaret, and said: "Here is one of your dear books of Philaret, which allows meat to be eaten on Holy Thursday and Holy Saturday." Nikita, who had kept silence after the outburst of Sophia, could only mutter: "It is printed by such rascals as you."

It was, however, impossible—much as the Patriarch and the archbishops might argue—to overcome the Dissenters, who steadfastly reiterated their statements, with-

out listening to arguments of any kind. Havánsky walked up and down the hall, but made no attempt to preserve order. Meanwhile, it was getting late, and it was time for Vespers, which neither party was willing to omit. Besides that, all were faint and weary, having eaten nothing since morning, and Sophia was glad of a pretext for closing this unruly assembly. She declared that, on account of the approach of Vesper time, it was impossible to carry on the conference any longer, and that an Imperial *ukase* about the matter would be issued afterward. The Princess retired to an inner room of the palace, together with the Patriarch and the archbishops.

The Dissenters ran in a crowd down the Red Staircase, and, lifting up their hands, with two fingers, cried: "This is the way we should cross ourselves; this is the way." On all sides were heard cries from the peo-

ple: "How did the matter end?" "Why, our side beat them," was shouted in return. "We argued down all the archbishops and overcame them. This is the way to pray. This is the way to pray. Cross yourselves." They then hastened to the Lobnôé Place, followed by the crowd. There they began again to explain the Solovétsky pamphlets; and then, after chanting a hymn, and raising their hands again with a two-fingered cross, they set out for the Yaúlla suburb, many of them so tired that they fell swooning on the road. At the quarters of the Titóf, they were met by ringing of bells, and after performing a triumphal service in the Church of the Savior they went home.

Sophia saw there was no use trying to convince the Dissenters by argument, and took measures of another kind. She called the delegates of the Streltsi together, and begged them not to desert the Tsars for these old monks, recalled their faithful services to the dynasty, and succeeded in persuading them,—some by promises, others by money, and others again by rewards and favors. More than this, the Streltsi were invited to the palace, in detachments of a hundred at a time, and were feasted with beer, mead, and wine. The Streltsi were not all Dissenters, and but few of them had the slightest conception of the matter in question. As before, on the 15th of May, they had murdered Matvéief and the rest in support of the dynasty, so now they had believed the Holy Church to be in danger. It was, therefore, comparatively easy for Sophia to persuade them. When the Dissenters came to complain to them of their desertion, they began to beat and revile them, and call them disturbers of the people. Some of the leading Dissenters were seized and delivered up to the authorities. There were no great formalities of trial, and sentence was soon passed. Nikíta was beheaded a week afterward, on the 21st of July, on the Red Place; while his companions, whose punishment was mitigated through the interference of Havánsky, were imprisoned in various monasteries. The adherents of the Dissenters, in Moscow, were obliged to conceal their feelings.

The reign of Sophia was a grievous time for the Dissenters. They were persecuted and suppressed, and often driven into open conflict with the troops sent against them. The State, with its material force, with its sword, had taken the place of the church, with its spiritual force, in punishing heresy. After the siege of the Solovétsky Monastery, many Dissenters had given up praying for the Tsar; now, as an effect of the persecutions of Sophia, they began to consider the Tsar as Antichrist, a feeling which increased during the rule of Peter.

The Dissenters were mistaken in putting themselves forward as representatives of the popular feelings and aspirations; the nation was divided on religious topics, and no hearty support was accorded to them. But this was one of the last of the many struggles of the Russian people against autocracy and centralization, and the boldness and courage of Sophia, while warding off a present danger, made, at the same time, a clearer field for the development of the Imperial power by her brother Peter.



CROSS OF PETER.

APRIL.

O RAINY days! O days of sun!
What are ye all when the year is done?
Who shall remember sun or rain?

O years of loss! O joyful years!
What are ye all when heaven appears?
Who shall look back for joy or pain?

A SUMMER'S DIVERSION.

"FOR one, *I* don't trust them yaller-haired, smooth-spoke women! I never see one on 'em yet that wa'n't full o' Satan."

It was Mrs. Rhoda Squires who uttered the above words, and she uttered them with considerable unnecessary clatter of the dishes she was engaged in washing. Abby Ann, a lank, dyspeptic-looking girl of fifteen or sixteen, was wiping the same, while the farmer himself was putting the finishing touches to his evening toilet. That toilet consisted, as usual, of a good wash at the pump, the turning down of his shirt-sleeves, and a brief application of the family comb, which occupied a convenient wall-pocket at one side of the small kitchen mirror—after which the worthy farmer considered himself in full dress, and ready for any social emergency likely to occur at Higgins' Four Corners.

"No," said Abby Ann, in response to her mother's remark, "she aint no beauty, but her clo'es does fit elegant. I wish I hed the pattern o' that white polonay o' hern, but I wouldn't *ask* her for it—no, not to save her!" she added, in praiseworthy emulation of the maternal spirit.

"Oh, you women folks!" interposed the farmer. "You're as full of envy 'n' backbitin' as a beech-nut's full o' meat! Beauty! Ye don't know what beauty means. I tell you she *is* a beauty,—a real high-steppin' out-an'-out beauty!"

"She's as old as I be, every bit!" snapped Mrs. Squires. "An' she haint got a speck o' color in her cheeks—an' she's a widder at that!"

Farmer Squires turned slowly around and deliberately surveyed the wiry, stooping figure of his wife from the small, rusty "pug" which adorned the back of her aggressive little head, and the sharp, energetically moving elbows, down to the hem of her stiffly starched calico gown.

"Look-a-here, Rhody," said he, a quizzical look on his shrewd, freckled countenance, "you've seen Gil Simmonses thorough-bred? Wall—that mare is nigh onto two year older'n our old Sal, but I swanny —"

Undoubtedly the red signal which flamed from Mrs. Squires's sallow cheeks warned her husband that he had said more than enough, for he came to a sudden pause, seized upon a pair of colossal cow-hide shoes, upon which he had just bestowed an unusual

degree of attention in the way of polish, and disappeared in the direction of the barn.

"He's jist as big a fool as ever!" she ejaculated. "The Lord knows *I* didn't want no city folks a-wearin' out *my* carpets, an' a-drinkin' up *my* cream, an' a-turnin' up their noses at *me*! But no—ever sence he heared that Deacon Fogg made nigh onto a hunderd dollars last year a-keepin' summer-boarders, his fingers has been a-itchin' an' his mouth a-waterin', an' nothin' for't but I must slave myself to death the whole summer for a pack o' stuck-up —"

She paused—for a soft rustle of garments and a faint perfume filled the kitchen, and turning, Mrs. Squires beheld the object of her vituperation standing before her.

She was certainly yellow-haired, and though not "every bit as old" as her hostess, a woman whose first youth was past; yet so far as delicately turned outlines, and pearly fairness of skin go, she might have been twenty. The eyes which met Mrs. Squires's own pale orbs were of an intense, yet soft, black, heavy-lidded and languid, and looked out from beneath their golden fringes with a calm, slow gaze, as if it were hardly worth their while to look at all. A smile, purely conventional, yet sweet with the graciousness of good breeding, parted the fine, soft lips.

Her mere presence made the room seem small and mean, and Mrs. Squires, into whose soured and jealous nature the aspect of beauty and grace ate like a sharp acid, smarted under a freshly awakened sense of her own physical insignificance.

She received her guest with a kind of defiant insolence, which could not, however, conceal her evident embarrassment, while Abby Ann retreated ignominiously behind the pantry door.

"I came to ask if Mr. Squires succeeded in finding some one to take us about," said the lady. "He thought he could."

Her voice was deep-toned and sweet, her manner conciliatory.

"I believe he did," replied Mrs. Squires, curtly. "Abby Ann, go tell your father Mis' Jerome wants him."

Abby Ann obeyed, and the lady passed out into the front hall, and to the open door. A cascade of filmy lace and muslin floated from her shoulders and trailed across the shiny oil-cloth. As the last frill swept

across the threshold, Mrs. Squires closed the door upon it with a sharp report.

Before the door a little girl was playing on the green slope, while an elderly woman with a grave, kindly face sat looking on.

Farmer Squires, summoned by his daughter, came round the corner of the house. He touched his straw hat awkwardly.

"They's a young feller," he said, "that lives a mile or so up the river, that has a tiptop team—a kivered kerridge an' a fustrate young hoss. His folks has seen better days, the Grangers has, an' Rob is proud as Lucifer, but they's a big mortgage on the farm, an' he's 'mazin' ambitious ter pay it off. So when I told him about you, he said he'd see about it. He wouldn't let no woman drive his hoss, but he thought mebber he'd drive ye round hisself. Shouldn't wonder if he was up to-night."

"I wish he might come," said the lady. "My physician said I must ride every day, and I am too cowardly to drive if the horse were ever so gentle."

"No—I guess you couldn't hold in Rob's colt with them wrists," said he, glancing admiringly at the slender, jeweled hands. "I shouldn't wonder if that was Rob now."

At this moment wheels were heard rapidly approaching, and a carriage appeared in sight. A young man was driving. He held the reins with firm hand, keeping his eyes fixed upon the fine-stepping animal, turned dexterously up the slope, brought the horse to a stand-still before the door and sprang lightly to the ground.

He was a remarkable-looking young fellow, tall above the average, and finely proportioned. Hair and mustache were dark, eyes of an indescribable dusky gray, and shaded by thick, black brows. A proud yet frank smile rested on his handsome face.

"Hello, Rob," said Farmer Squires. "Here's the lady that wanted ter see ye. Mister Granger, Mis' Jerome."

The lady bowed, with a trace of hauteur in her manner at first, but she looked with one of her slow glances into the young man's face, and then extended her hand, and the white fingers rested for an instant in his brown palm. Granger returned her greeting with a bow far from awkward, while a rich color surged into his sun-browned face.

"That is a magnificent horse of yours, Mr. Granger," said Mrs. Jerome. "I hope he is tractable. I was nearly killed in a runaway once, and since then I am very timid."

"Oh, he is very gentle," said Granger, caressing the fiery creature's beautiful head.

"If you like, I will take you for a drive now—if it is not too late."

"Certainly, I would like it very much. Nettie," she said, turning to the woman, "bring my hat and Lill's, and some wraps."

The woman obeyed, and in a few moments Mrs. Jerome and her child were whirling over the lovely country road. Their departure was witnessed by the entire Squires family, including an obese dog of somnolent habits, and old Sal, the gray mare, who thrust her serious face over the stone wall opposite, and gazed contemplatively down the road after the retreating carriage.

"Do you think you will be afraid?" asked Granger, as he helped Mrs. Jerome to alight.

"Oh no," she answered, with a very charming smile. "The horse is as docile as he is fiery. I shall enjoy the riding immensely. Do you think you can come every day?"

"I shall try to—at least for the present."

Mrs. Jerome watched the carriage out of sight.

"How very interesting!" she was thinking. "Who would dream of finding such a face here! And yet—I don't know—one would hardly find such a face out in the world. Perhaps it will not be so dull after all. I thought they were all like Squires!"

For several succeeding weeks there was seldom a day when the fiery black horse and comfortable old carriage did not appear before the farm-house door, and but few of those days when Mrs. Jerome did not avail herself of the opportunity, sometimes accompanied by the child and Nettie, oftener by the child alone.

The interest and curiosity with which young Granger had inspired Mrs. Jerome in the beginning, deepened continually. A true son of the soil, descendant of a long line of farmers, whence came this remarkable physical beauty, this refined, almost poetic, temperament, making it impossible for him, in spite of the unconventionality of his manner, to do a rude or ungraceful act? It was against tradition, she thought,—against precedent. It puzzled and fascinated her. She found it impossible to treat him as an inferior, notwithstanding the relation in which he stood to her. Indeed, she soon ceased to think of that at all. The books which she took with her upon their protracted drives were seldom opened. She found it pleasanter to lie back in the

corner of the carriage, and watch the shifting panorama of hill and forest and lake through which they were driving. That the handsome head with its clustering locks and clear-cut profile, which was always between her and the landscape, proved a serious obstruction to the view, and that her eyes quite as often occupied themselves with studying the play of those mobile lips, and the nervous tension of those sun-browned hands upon the reins, were, perhaps, natural and unavoidable.

She talked with him a great deal, too, in her careless, fluent way, or rather to him, for the conversation on Granger's part was limited to an occasional eager question, a flash of his fine eyes, or an appreciative smile at some witty turn. She talked of many things, but with delicate tact avoided such themes as might prove embarrassing to an unsophisticated mind—including books.

It was, therefore, with a little shock of surprise that she one day found him buried in the pages of Tennyson, a volume of whose poems she had left upon the carriage seat while she and Lill explored a neighboring pasture for raspberries.

He was lying at full length in the sweet-fern, one arm beneath his head, his face eager and absorbed. He did not notice her approach, and she had been standing near him for some moments before he became aware of her presence. Then, closing the book, he sprang to his feet.

"So you read poetry, Mr. Granger?" she said, arching her straight brows slightly.

"Sometimes," he answered. "I have read a good many of the old poets. My grandfather left a small library, which came into my possession."

"Then you have read Shakspeare ——" began the lady.

"Yes," interrupted Granger, "Shakspeare, and Milton, and Pope, and Burns. Is it so strange?" he asked, turning upon her one of his swift glances. "If one plowman may write poetry another plowman may read it, I suppose."

He spoke with bitterness, a deep flush rising to his temples.

"And have you read modern authors too?"

"Very little. There is no opportunity here. There is nothing here—nothing!" he answered, flinging aside a handful of leaves he had unwittingly gathered.

"Why do you stay here, then?"

The question sprang, almost without

volition, from her lips. She would gladly have recalled it the next moment.

Granger gave her another swift glance, and it seemed to her that he repressed the answer which was already upon his tongue. A strange, bitter smile came to his lips.

"Let the shoe-maker stick to his last," he said, turning toward the carriage, "and the farmer to his plow."

During the homeward ride he was even more taciturn than usual. At the door, Mrs. Jerome offered him the volume of Tennyson. He accepted it, with but few words.

When he returned it, a few days later, it opened of itself, and between the leaves lay a small cluster of wild roses, and some lines were faintly marked. They were these:

"When she made pause, I knew not for delight;
Because with sudden motion from the ground
She raised her piercing orbs and filled with light
The interval of sound."

"Cleopatra!" Mrs. Jerome repeated softly, "and like her, I thought there were 'no men to govern in this wood.' Poor fellow!"

It was a few days, perhaps a week, later, when Mrs. Jerome, who to the mystification of her host and hostess had received no letters, and, to the best of their knowledge, had written none, up to this time, followed a sudden impulse, and wrote the following epistle:

"MY DEAR FRIEND AND PHYSICIAN:—You advised, no, commanded me, to eschew the world for a season, utterly and completely. I have obeyed you to the letter. I will spare you details—enough that I am gaining rapidly, and, wonderful to say, I am not in the least *ennuyée*. On the contrary. The cream is delicious, the spring water exquisite, the scenery lovely. Even the people interest me. I am your debtor, as never before, and beg leave to sign myself,

Your grateful friend and patient,
HELEN JEROME.

"P. S.—It would amuse me to know what the world says of my disappearance. Keep my secret, on your very soul. H. J."

Midsummer came, and passed, and Mrs. Jerome still lingered. In her pursuit of health she had been indefatigable. There was hardly a road throughout the region which had been left untried, hardly a forest path unexplored, or a mountain spring untasted.

"For a woman that sets up for delicate," remarked Mrs. Squires, as from her point of observation behind the window-blinds she watched Mrs. Jerome spring with a girl's elastic grace from the carriage, "for a woman that sets up for delicate, she can

stan' more ridin' around, an' scramblin' up mountains, than any woman I ever see. I couldn't do it—that's sure an' sartain!"

"It's sperrit, Rhody, sperrit. Them's the kind o' women that 'll go through fire and flood to git what they're after."

"Yes, an' drag everybody along with 'em, if they wants to," added Mrs. Squires, meaningly.

There was one place to which they rode which held a peculiar charm for Mrs. Jerome,—a small lake, deep set among the hills and lying always in the shadow. Great pines grew down to its brink and hung far out over its surface, which was almost hidden by thickly growing reeds and the broad leaves and shining cups of water-lilies. Dragon-flies darted over it, and a dreamy silence invested it. A boat lay moored at the foot of the tangled path which led from the road, and they often left the carriage, and rowed and floated about until night-fall among the reeds and lilies.

They were floating in this way, near the close of a sultry August afternoon. Lill lay coiled upon a shawl in the bottom of the boat, her arms full of lilies whose lithe stems she was twining together, talking to herself, meanwhile, in a pretty fashion of her own.

Granger was seated in the bow of the boat, with folded arms, and eyes fixed upon the dark water. His face was pale and moody. It had worn that expression often of late, and he had fallen into a habit of long intervals of silence and abstraction.

The beautiful woman who sat opposite him, idly trailing one hand, whiter and rosier than the lily it held, in the water, seemed also under some unusual influence. She had not spoken for some time. Now and then she would raise the white lids of her wonderful eyes, and let them sweep slowly over the downcast face of Granger.

The dusky water lay around them still as death, reflecting in black masses the overhanging pines. The air was warm and full of heavy odors and drowsy sounds, through which a bird's brief song rang out, now and then, thrillingly sweet.

The atmosphere seemed to Mrs. Jerome to become every moment more oppressive. A singular agitation began to stir in her breast, which showed itself in a faint streak of red upon either cheek. At last this feeling became unendurable, and she started with a sudden motion which caused the boat to rock perilously.

Granger, roused by this movement, seized

the oars, and with a skillful stroke brought the boat again to rest.

"Will you row across to the other side?" the lady said. "I saw some rare orchids there which must be in bloom by this time."

Granger took up the oars again and rowed as directed. When the orchids had been found and gathered, at Mrs. Jerome's request he spread her a shawl beneath a tree, and seated himself near her.

"How beautiful it is here!" she said, after a pause. "I would like to stay and see the moon rise over those pines. It rises early to-night. You don't mind staying?" she added, looking at Granger.

"No—" he answered, slowly, "I don't mind it in the least."

"How different it must look here in winter!" she said, presently.

"Yes; as different as life and death."

"I cannot bear to think I shall never see it again," she said, after another and longer pause, "and yet I must leave it so soon!"

"Soon!" Granger echoed, with a start. "You are going away soon, then?" he asked, in a husky voice.

"Yes—very soon—in two weeks, I think."

Granger made no reply. He bent his head and began searching among the leaves and moss. His eyes fell upon one of the lady's hands, which lay carelessly by her side, all its perfections and the splendor of its jewels relieved against the crimson background of the shawl.

He could not look away from it, but bent lower and lower, until his hair and his quick breath swept across the fair fingers.

At the touch a wonderful change passed over the woman. She started and trembled violently—her face grew soft and tender. She raised the hand which was upon her lap, bent forward and laid it, hesitatingly, tremblingly, upon the bowed, boyish head.

"Robert! Robert!" she whispered.

Granger raised his head. For a moment, which seemed an age, the two looked into each other's face. Hers was full of yearning tenderness and suffused with blushes—his, rigid and incredulous, yet lighted up with a wild joy. A hoarse cry broke from his lips—he thrust aside the hand which lingered upon his head, sprang to his feet, and went away.

The color faded from Mrs. Jerome's face. She sat, for a moment, as if turned to stone, her eyes, dilated and flashing, fixed upon Granger's retreating figure. Then, with an impetuous gesture, she rose and went to look for Lill. A scream from the little girl fell

upon her ears at the same moment. She had strayed out upon a log which extended far into the water, and stood poised, like a bird, upon its extreme end. Round her darted a blue-mailed dragon-fly, against which the little arms were vainly beating. Mrs. Jerome sprang toward her, but Granger was already there. As he gave the frightened child into her mother's arms, he looked into her face. She returned his imploring gaze with a haughty glance, and walked swiftly toward the boat. He took his seat in the bow and rowed across the lake, his white face set shoreward. Lill buried her scared little face in her mother's lap, and no one spoke. As they landed, a great, dark bird rose suddenly out of the bushes, and with a hideous, mocking cry, like the laugh of a maniac, swept across the water. The woman started and drew the child closer to her breast.

They drove along in silence until within a mile of the Squires' farm, when, without a word, Granger turned into a road over which their drives had never before extended. It was evidently a by-way, and little used, for grass grew thickly between the ruts. On the brow of a hill he halted.

Below, in the valley, far back from the road-side, stood an old, square mansion, of a style unusual in that region. It must have been a place of consequence in its day and generation. The roof was hipped and broken by dormer windows, and a carved lintel crowned the door-way. An air of age and decay hung about it and the huge, black barns with sunken roofs, and the orchard, full of gnarled and barren trees, which flanked it. A broad, grass-grown avenue, stiffly bordered by disheveled-looking Lombardy poplars, led up to the door.

Granger turned slowly, and looked full into Mrs. Jerome's face. His own was terribly agitated. Doubt, questioning, passionate appeal, spoke from every feature.

"That is the old Granger place," he said, in a strange, choked voice, with a gesture toward the house, "and that"—as a woman appeared for an instant in the door-way—"that woman — is *my wife!*"

Mrs. Jerome's lips parted, and a quick breath escaped them. The desperate look in Granger's face intensified. His eyes seemed endeavoring to pierce into her inmost soul. His lips moved as if to speak again, but speech failed him.

It was but a passing ripple on the surface of her high-bred calm. A smile, the slow, sweet, slightly scornful smile he knew so

well, came to her lips again. She raised her eye-glasses and glanced carelessly over the scene.

"Nice old place!" she said, in her soft, indifferent way. "Quite an air about it, really!"

Granger turned and lashed the horse into a gallop. His teeth were set—his blue-gray eyes flashed.

When the door was reached he lifted the woman and her child from the carriage, and drove madly away, the impact of the wheels with the rocky road sending out fierce sparks as they whirled along.

Mrs. Jerome gathered her lilies into her arms and went slowly up to her room.

Several days passed, and Robert Granger did not appear. The harvest was now at its height, and the farmers prolonged their labors until sunset, and often later. This was the ostensible reason for his remaining away. During these days Mrs. Jerome was in a restless mood. She wandered continually about the woods and fields near the farm-house, remaining out far into the bright, dewless nights. One evening she complained of headache, and remained in-doors, sitting in *negligée* by the window, looking listlessly out over the orchard. Nettie came in from a stroll with Lill, and gave her mistress a letter.

"We met Mr. Granger, and he gave me this, madam," she said, respectfully, but her glance rested with some curiosity upon the face of Mrs. Jerome as she spoke.

The letter remained unopened upon her lap long after Nettie had gone with the child to her room. Finally, she tore the envelope open and read:

"What is the use of struggling any longer? You have seen, from the first day, that I was entirely at your mercy. There have been times when I thought you were coldly and deliberately trying your power over me; and there have been other times when I thought you were laughing at me, and I did not care, so long as I could see your face and hear your voice. I never allowed myself to think of the end. Now all is changed. What has happened? I am too miserable—and too madly happy—to think clearly; but, unless I am quite insane, I have heard your voice speaking my name, and I have seen in your face a look which meant—no, I *cannot* write it! It was something I have never dared dream of, and I cannot believe it, even now; and yet, I *cannot* forget that moment! If it is a sin to write this—if it is a wrong to you—I swear I have never meant to sin, and I would have kept silent forever but for that moment. Then, too, it flashed upon me for the first time that you did not know I was not free to love you. It *must* be that you did not know—the doubt is an insult to your womanhood—and yet, when I tried to make sure of this, how you baffled me!

But still that moment remains unforgotten. What does it all mean? I must have an answer! I shall come to-morrow, at the usual time. If you refuse to see me, I shall understand. If not—what then?
“R. G.”

The letter fell to the floor, and Helen Jerome sat for a while with heaving breast and hands clasped tightly over her face. Then she rose and paced up and down the chamber, pausing at length before one of the photographs—a strange, weird thing. Through somber, lurid vapors swept the figures of two lovers, with wild, wan faces, clasped in an eternal embrace of anguish. She looked at the picture a long time with a brooding face. In the dusk the floating figures seemed to expand into living forms, their lips to utter audible cries of despair.

“Even at that price?”

She shuddered as the words escaped her lips, and turned away. There was a tap at the door, and, before she could speak, a woman entered,—a spare, plain-featured woman, dressed in a dark cotton gown and coarse straw hat. There was something gentle, yet resolute, in her manner, as she came toward Mrs. Jerome, her eyes full of repressed, yet eager, scrutiny.

“Good evenin’, ma’am,” she said, extending a vinaigrette of filigree and crystal. “I was comin’ up this way an’ I thought I’d bring ye your bottle. Leastways, I s’pose it’s yourn. It fell out o’ Rob’s pocket.”

She let her eyes wander while she was speaking over the falling golden hair, the rich *robe-de-chambre*, and back to the beautiful proud face.

“Thank you, it *is* mine,” said Mrs. Jerome. “Are you Robert Granger’s mother?”

“No, ma’am. I am his wife’s mother. My name is Mary Rogers.”

Mrs. Jerome went to the window and seated herself. The hem of her dress brushed against the letter, and she stooped and picked it up, crushing it in her hand. The visitor did not offer to go. She had even removed her hat, and stood nervously twisting its ribbons in her hard, brown fingers.

“Will you sit down, Mrs. Rogers?”

The woman sank upon a chair without speaking. She was visibly embarrassed, moving her hands and feet restlessly about, and then bursting into sudden speech.

“I’ve got somethin’ I want to say to ye, Mis’ Jerome. It’s kind o’ hard to begin—harder’n I thought ’twould be.”

She spoke in a strained, trembling voice, with many pauses.

“It’s something that ought to be said, an’ there’s nobody to say it but me. Perhaps

—you don’t know—that folks round here is a-talkin’ about—about you an’ Rob.”

Mrs. Jerome smiled—a scornful smile which showed her beautiful teeth. The woman saw it, and her swarthy face flushed.

“I don’t suppose it matters to you, ma’am, if they be,” she said, bitterly, “an’ it aint on your account I come. It’s on Ruby’s account. Ruby’s my darter. Oh, Mis’ Jerome,”—she dropped her indignant tone, and spoke pleadingly,—“you don’t look a bit like a wicked woman, only proud, an’ used to havin’ men praise ye, an’ I’m sure if you could see Ruby you’d pity her, ma’am. She’s a-worryin’ an’ breakin’ her heart over Rob’s neglectin’ of her so, but she don’t know what folks is a-sayin’. I’ve kep’ it from her so far, but I’m afeard I can’t keep it much longer, for folks keeps a throwin’ out ’n’ hintin’ round, and if Ruby should find it out—the way she is now—it’d *kill* her!”

She stopped, sobbing and rocking herself to and fro.

“I never wanted her to *hev* Rob Granger,” she began again, speaking hurriedly, “an’ I tried to hender it all I could. But ’twasn’t no use. I knew ’twould come to this, sooner or later. ’Twas in his father, an’ it’s in him. The Grangers was all of ’em alike—proud an’ high-sperrited, an’ never knowin’ their own minds two days at a time. It’s in the blood, an’ readin’ po’try an’ sich don’t make it no better. I knowed Ruby wa’n’t no match for Rob; she’s gentle an’ quiet, an’ aint got much book-larin’. But her heart was sot on him, poor gal!”

And again she paused, sobbing gently and wiping her eyes on her apron. Mrs. Jerome rose and went over to her. A wonderful change had passed over her. Every trace of pride and scorn had faded from her face. She was gentle, almost timid, in manner, as she stood before the weeping woman.

“Mrs. Rogers,” she said, kindly, “I cannot tell you how sorry I am. It is all unnecessary, I assure you. It is very foolish of people to talk. I shall see that you have no more trouble on my—on this account. If I had known”—she hesitated, stammering. “You see, Mrs. Rogers, I did not even know that Robert Granger was married. If I had, perhaps —”

The woman looked up incredulously. The blood tingled hot through Mrs. Jerome’s veins as she answered, with a sting of humiliation at her position.

“It may seem strange—it *is* strange, but

no one has ever mentioned it to me until—a few days ago. Besides, as I tell you, there is no need for talk. There *shall* be none. You can go home in perfect confidence that you will have no further cause for trouble—that I can prevent.”

Mrs. Rogers rose and took the lady's soft hand in hers.

“God bless ye, ma'am. Ye'll do what's right, I know. You must forgive me for thinking wrong of ye, but you see —”

She broke off in confusion.

“It is no matter,” said Mrs. Jerome. “You did not know me, of course. Good-night.”

When the door had closed upon her visitor, she stood for a while motionless, leaning her head wearily against the window-frame.

“Strange,” she said to herself, “that she should have reminded me of—mother! It must have been her voice.”

A breeze strayed in at the window, and brought up to her face the scent of the lilies which stood in a dish upon the bureau. She seized the bowl with a hasty gesture, and threw the flowers far out into the orchard.

Mrs. Jerome arose very early the next morning and went down for a breath of the fresh, sweet air. Early as it was, the farmer had been to the village to distribute his milk, and came rattling up the road with his wagon full of empty cans. He drove up to the door, and, with an air of importance, handed the lady a letter, staring inquisitively at her haggard face as he did so. The letter was merely a friendly one from her physician, in answer to her own, and said, among other things:

“Van Cassalear is in town. All my ingenuity was called into action in the effort to answer his persistent inquiries in regard to you. As glad as I am that you are so content, and inured to human suffering as I am supposed to be, I could not but feel a pang of sympathy for him. His state is a melancholy one. The world has long since ceased conjecturing as to your whereabouts. You are one of those privileged beings who are at liberty to do and dare. Your mysterious disappearance is put down with your other eccentricities.”

Although, under ordinary circumstances, not a woman to care for a pretext for anything she chose to do, she allowed the reception of this letter to serve in the present instance as an excuse for her immediate departure—for she had resolved to go away at once.

The surprise of Mr. Squires when her intention was made known to him was great, and tinged with melancholy—a melancholy which his wife by no means shared.

But his feelings were considerably assuaged by the amount of the check handed him by Nettie, which was far greater than he had any reason to expect.

“I might 'a' got Rob to take 'em down to the station, if I'd a-known it sooner,” he remarked to his wife, in Mrs. Jerome's hearing, “but I seen him an hour ago drivin' like thunder down toward Hingham, an' he wont be back in time. I guess old Sal can drag the folks down to the station, an' I'll see if I can get Tim Higgins to take the things. Time I's about it, too. Train goes at one.”

Mrs. Jerome went to her room and dressed herself in traveling attire. Leaving Nettie to finish packing, she took her hat and went out and down the road, walking rapidly and steadily onward. All along the road-side August was flaunting her gay banners. Silvery clematis and crimsoning blackberry vines draped the rough stone walls; hard-hack, both pink and white, asters and golden-rod, and many a humble, nameless flower and shrub, filled all the intervening spaces; yellow birds swung airily upon the purple tufts of the giant thistles, and great red butterflies hovered across her pathway. She passed on, unheeding, until the grassy by-road was reached, into which she turned, and stood for a moment on the summit of the hill, looking down upon the Granger homestead. A woman came out as she looked, and leaned over the flowers which bloomed in little beds on each side of the door-way. Mrs. Jerome half turned, as if to retrace her steps, and then walked resolutely down the hill and up the avenue. The woman saw her coming, stared shyly from beneath her hand, in rustic fashion, for a moment, and then ran into the house, where she was seen peeping from between the half-closed window-blinds.

As she came nearer the house, Mrs. Jerome slackened her steps. Her limbs trembled, she panted slightly, and a feeling of faintness came over her. The woman she had seen came again to the door, and stood there silently as if waiting for the stranger to speak—a timid, delicate young creature, with great innocent blue eyes and apple-bloom complexion. The lady looked into the shy face a moment and came forward, holding out her gloved hand.

“Are you Mrs. Granger?”

The little woman nodded, and the apple-bloom color spread to her blue-veined temples.

“I am Mrs. Jerome,” she continued.

"You must have heard your—husband speak of me."

It was wonderful—the gracious calmness of her manner, the smooth cadence of her voice, the serene smile upon her lips.

"Yes," answered Mrs. Granger, simply, "I've heard tell of you."

Meantime she was studying her guest with innocent curiosity—the lovely proud face, the supple figure, the quiet elegance of the toilet, with all its subtle perfection of detail. It did not irritate her as it did Mrs. Squires; it only filled her with gentle wonder and enthusiasm. She tried at length to shake off the timidity which possessed her.

"You must be real tired," she said gently. "It's a long walk. Wont you come in?"

"Thank you," said the lady. "I think I *am* very tired. If you would be so kind as to give me a chair, I would sit here in the shade awhile."

She sank into the chair which Mrs. Granger brought, and drank eagerly the cool water which she proffered.

"Thank you," she said. "It is pleasant here, very. How lovely your flowers are."

"Yes," said Mrs. Granger, with a show of pride, "I love flowers, and they always bloom well for me." She went to the beds and began gathering some of the choicest. At the same moment, Mrs. Rogers came through the hall. As she saw the visitor, her face flushed, and she glanced suspiciously, resentfully, from Mrs. Jerome to her daughter.

The lady rose.

"It's Mis' Jerome, mother," said Ruby, simply, "the lady that stays at Squireses."

Mrs. Jerome bowed, and a look of full understanding passed between the two. Ruby, gathering her flowers, saw nothing of it.

"I am going away, Mrs. Granger," said the lady. "Circumstances require my immediate return to the city. I came to leave a message with you for—your husband, as he is not at home. Tell him I thank him for the pleasure he has given me this summer."

"I'm real sorry you took the trouble to come down," said Mrs. Granger. "It's a long walk, an' Squires could 'a' told Rob to-night."

"Yes, I know," said the lady, consulting her watch, "but I wanted a last walk."

She held the little woman's hand at parting, and looked long into the shy face. Then, stooping, she lightly kissed her forehead, and, with the flowers in her hand, went down the grassy avenue, up the hill, and out of sight.

Robert Granger came home late in the afternoon. He drove directly into the barn, and proceeded to unharness and care for the jaded beast, which was covered with foam and dust. He himself was haggard and wild-eyed, and he moved about with feverish haste. When he had made the tired creature comfortable in his stall, he went to the splendid animal in the one adjoining and began to bestow similar attentions upon him. While he was thus engaged, Mrs. Rogers came into the stable. Her son-in-law hardly raised his eyes. She watched him sharply for a moment, and came nearer.

"Aint ye comin' in to get somethin' to eat, Rob?"

"I have been to dinner," was the answer.

"Rob," said the woman, quietly, "ye might as well let that go—ye wont need Dick to-day."

Granger started, almost dropping the card he was using.

"What do you mean?" he asked, with an effort at indifference, resuming his work on Dick's shining mane.

"The lady's gone away," said Mrs. Rogers, steadily watching him.

"What!" cried Granger, glaring fiercely across Dick's back. "What did you say? Who's gone away?"

"The lady—Mis' Jerome," repeated the woman. "She come down herself to leave word for ye, seein' that you wa'n't at home. She was called away unexpected. Said she'd enjoyed herself first-rate this summer—an' was much obleeged to ye for your kindness."

Granger continued his labor, stooping so low that his mother-in-law could only see his shoulders and the jetty curls which clustered at his neck. She smiled as she looked—a somewhat bitter smile. She was a good and gentle creature, but Ruby was her daughter—her only child. After a moment or two she went away.

When she was out of hearing, Granger rose. He was pale as death, and his forehead was covered with heavy drops. He leaned weakly against Dick, who turned his fine eyes lovingly on his master and rubbed his head against his sleeve.

Granger hid his face upon his arms.

"My God!" he cried, "is that the answer?"

It *was* the answer. It was all the answer Granger ever received. He did not kill himself. He did not attempt to follow or even write to her. Why should he? She had come and had gone,—a beautiful, bewildering, maddening vision.

Neither did he try the old remedy of dissipation, as a meaner nature might have done; but he could not bear the quiet meaning of Mrs. Rogers' looks, nor the mute, reproachful face of his wife, and he fell into a habit of wandering with dog and gun through the mountains, coming home with empty game-bag, late at night, exhausted and disheveled, to throw himself upon his bed and sleep long, heavy slumbers. Without knowing it, he had taken his sore heart to the surest and purest counselor; and little by little those solitary communings with nature had their healing effect.

"Let him be, Ruby," her mother would say, as Ruby mourned and wondered. "Let him be. The Grangers was all of 'em queer. Rob'll come round all right in course of time."

Weeks and months went by in this way, and one morning, after a night of desperate pain and danger, Robert Granger's first-born was laid in his arms. Then he buried his face in the pillow by pale, smiling Ruby and sent up a prayer for forgiveness and strength. True, only God and attending angels heard it, but Ruby Granger was a happier woman from that day.

Mrs. Van Cassalear was passing along the city street, leaning upon her husband's arm. It was midsummer. "Everybody

was out of town, and the Van Cassalears were only there for a day, *en passant*. They were walking rapidly, the lady's delicate drapery gathered in one hand, a look of proud indifference upon her face.

"Pond-lilies! Pond-lilies!"

She paused. Upon a street-corner stood a sun-burned, bare-foot boy, in scant linen suit and coarse farmer's hat. His hands were full of lilies, which he was offering for sale.

Mrs. Van Cassalear dropped her husband's arm and the white draperies fell unheeded to the pavement. She almost snatched the lilies from the boy's hands, and bowed her face over them.

The city sights and sounds faded away. Before her spread a deep, dark lake, its surface flecked with lilies. Tall pines bent over it, and in their shadow drifted a boat, and an impassioned, boyish face looked at her from the boat's prow.

"Six for five cents, lady, please!"

"Do you want the things, Helen?" said Van Cassalear, the least trace of impatience in his voice. "If you do, let me pay the boy and we'll go on. People are staring."

The lady raised her eyes and drew a deep breath.

"No," she said, "I will not have them."

She returned the lilies, with a piece of money, to the astonished boy, gathered her drapery again into her hand, and swept on.

ROCKY MOUNTAIN MULES.



THE RIDING ANIMALS.

AMONG the most vivid recollections that remain to those who have roughed it in the Far West are those connected with mules. During two years of service with Dr. Hayden's corps the present writer had

a variety of experiences, grave and gay, with the animals so long of ear and quick of heel, which it may amuse some one to have recounted.

It goes without saying that in making

original explorations through so lofty and broken a region as is comprised in the term Rocky Mountains, wheeled vehicles are out of the question. Before they can be used to any extent roads must be laboriously built, and it was one object of the surveys to discover the most practicable routes for these prospective highways. Explorers, meanwhile, had to trudge afoot or take to the saddle.

The Survey, during its many successive years of service, acquired a large herd of animals, which were kept from season to season, whenever worth it. The labor required was severe, and a superior grade of stock was needed. The great majority of these animals were mules, for their endurance is greater than that of horses, and their size and build are better suited for bearing burdens. This is so well understood by all mountaineers that, whereas you can buy a fair pack-pony for fifty dollars, or less, you must pay three times that amount for a good mule.

The rendezvous camp near Denver or Cheyenne having been organized, the laboring men hired (usually the same muleteers year after year), and the stores collected, the first thing done is to distribute the live stock. Herewith begin both the fun and the peril of the expedition.

The herd of a hundred or more animals, that have been ranging the open plains in the wildest license all winter, have just been "rounded up," and are at last penned in a corral by themselves. Steve Hovey, the head packer, now looks them over as they go careering round the confined space, and selects the quota of each division of the Survey. Some will require to be reshod, and those bravest of men, the Cheyenne blacksmiths, who would fearlessly straddle a thunderbolt if it needed an iron tip, unhesitatingly do the job whether the mule consents or not. Then the animals go back to the corral to fight and play, and to mature, by long consultations, the evil designs which they propose to execute during the coming campaign.

By this time the saddles and aparejos (Californian pack-saddles) have been repaired and distributed, the stores divided and as far as possible stowed in bags in order to be most conveniently lashed upon the mules' backs, and each man has studied how to bestow his bedding and small personal outfit most compactly. In place of trunks or valises, everything is stuffed into canvas cylinders each about the size of a section of

stove-pipe, which close by means of puckering-strings at the top. Nearly everything that each one carries must be inclosed in this one war-bag; but for the few fragile and shapely articles needful a pair of panier-boxes is given to each party. My writing-kit I stuffed into a small, soft traveling-bag, the last time I was out, and it carried very well. Of course such an arrangement precludes "boiled shirts" or "fried" goods of any sort. Your war-bag, like everything else, will be placed in that part of a mule's load where it will ride best, and the utmost strength of two men will be expended in drawing the lash-ropes tightly across it. Anything more linen than a handkerchief or whiter than any undershirt is, therefore, treated with scorn and derision in camp, and old trowsers and coats, heavy flannel shirts, coarse shoes and broad-brimmed felt hats are the *mode*.

Finally comes the gala-day when the mules are to be saddled for the first time after their long vacation, and everybody is on hand to see the fun.

The western pack-mule is small, sinewy, and, like old Joey Bagstock, "tough, sir, tough! but de-e-vlish sly!" Most of them are bred from Indian ponies and are born on the open plains. Having previously been lassoed and branded, when three years old they are driven (or inveigled) into a corral and exhibited for sale as *bronchos*. An untamed horse is a model of gentleness beside them. Sometimes they are accustomed at once to the saddle by one of those wonderful riders who can stick on the back of anything that runs, and more rarely they are broken to harness; but ordinarily their backs are trained to bear the pack, which is generally the only practicable method of transporting freight through these rugged mountains.

The first time the pack-saddles are put on, the excitement may be imagined. The green mule, strong in his youth, having been adroitly "roped" or lassoed, is led out into an open space, stepping timidly, but, not seeing any cause for alarm, quietly; before he understands what it all means, he finds that a noose of the rawhide lariat about his neck has been slipped over his nose, and discovers that his tormentors have an advantage. He pulls, shakes his head, stands upright on opposite ends, but all to no avail. The harder he pulls, the tighter the noose pinches his nostrils, so at last he comes down and keeps still. Then a man approaches slowly and circumspectly,

holding behind him a leather blinder which he seeks to slip over the mule's eyes. But two long ears stand in the way, and the first touch of the leather is the signal for two jumps—one by the beast and one by the man, for packers are wise enough in their day and generation to fight shy of the business end of a mule. The next attempt is less a matter of caution and more of strength, and here the animal has so much advantage that often it must be lassoed again and thrown to the ground.

It is a fine sight to witness the indignation of such a fellow! He falls heavily, yet holds his head high and essays to rise. But his fore-feet are manacled by ropes and his head is fast. Yet he will shake almost free, get upon his hind-feet, stand straight

upon the *sinch* (as the girth is termed), which holds firmly every hair-breadth, and will finally crease the contour of the mule's belly into the semblance of Cupid's bow. But this one pull suffices to set him springing again—bucking, now, with arched back and head between his knees, landing on stiff legs to jar his burden off, or falling full weight on his side and rolling over to scrape it free. He will sit on his haunches and hurl himself backward; will duck his head and turn a somersault; finally will stand still, trembling with anger and exhaustion, and let you lead him away, conquered.

Simply putting on the *aparejos* is enough for that day. On the next morning the riding animals are saddled, the light packs are placed upon the pack-mules and the jour-



READY TO BE PACKED.

up and dash down with all his weight in futile efforts for liberty. Secured with more ropes, allowed but three legs to stand upon and cursed frightfully, he *must* submit, though he never does it with good grace. It is not always, however, that this extremity is resorted to. Some animals make little resistance while the strange thing is being put upon their backs and the fastenings adjusted—all but one; but when an effort is made to put that institution called a crupper under a young mule's tail, language fails to express the character of the kicking! The light heels describe an arc from the ground to ten feet above it and then strike out at a tangent. They cut through the air like whip-lashes and would penetrate an impediment like bullets. But even mule-flesh tires. Strategy wins. The crupper is gained and the first hard pull made

ney into Cheyenne is made, where the mules, stores and laboring men start westward on a freight-train, each party going to some station convenient to its field of labor, while the regular corps of scientific workers waits behind for the luxurious evening express.

Arrived at the station where your party is to leave the railroad, field-work really begins. The first days are uncomfortable, but things soon settle to their places, and with the organization of duties comes the sense of having really cut loose from civilization. In an average party (one of the five or six sub-divisions of the Survey) there are six persons all told, and eight pack-mules suffice to carry the luggage. Besides these there are two extra pack-mules, four or five for riding and at least one horse.

The mountain mules all love company,

cling together and enjoy walking one behind the other in long file; but no mule has independence of judgment enough to lead a train, even with a bit in his mouth. On the other hand, all mules are "stuck



SINCHING APAREJOS.

after" a horse, as the muleteers phrase it, and advantage is taken of this to cause them to travel steadily, and to keep them together at night, by having a horse to lead the march. This horse has a stock-bell round its neck and is ridden by the cook, who is thus debarred from anything except steadily plodding along, while the others can ramble off from the train as much as they please. At night the bell-horse is hobbled and all the mules are turned loose to graze about the neighborhood, the tinkle of the bell giving us information of their position in the morning, for there is little fear that they will wander away from the horse unless stampeded, and that rarely occurs. Mules will absolutely go daft over a horse, and there are always fierce contests the first day a train starts out as to which shall have the coveted place next to the leader. It often happens that for weeks afterward the victor has to maintain his position by constant exercise of heels and teeth, and with much mulish profanity. I have seen two mules fight so incessantly for the place next the bell-horse when feeding, that they forgot to eat all day.

The first day's ride through the miserable outskirts of civilization is likely to be tiresome and unsatisfactory. You have not become accustomed to your mule, nor he to you. You are sun-burned, and your eyes smart with the alkali dust,—for the cool mountains are not yet reached,—and your muscles ache with the unwonted labor of riding. You have been gazed at by the few persons you met, and chaffed in the miners' camps. Going through a town or past a ranch the

mules have exerted themselves to enter every gate and door-way, to go anywhere and everywhere but where they ought; and the amount of caution, invective and hard-riding necessary to keep them together and under their respective packs has been vexatious and fatiguing, conducive neither to observation of scenery nor to the cultivation of Christian virtues.

At last the march is finished, and you hasten ahead, tumble off your beast and unsaddle by the time the train comes up, so that you can help remove the packs—an operation the sagacious mules undergo with the most exemplary quietude. A little later, when the animals have cooled, the aparejos are taken off, the bell-horse is hobbled, and the whole herd is turned loose for the night. Their first move is to roll, removing the perspiration, and scratching the backs grown hot and irritated under the heavy loads, which, at first, often average 250 or 300 pounds. Then, how they eat! The sun sets, twilight fades, the camp-fire is replenished, and still they munch, munch at the crisp grass; the stars come out and the riders go in, but the last glimpse of the mules in the darkness shows them with their noses to the ground. A pack-train intelligently cared for will actually grow fat upon a four or five months' trip of this kind, though they never get a mouthful of grain the whole time.



"ALL SET."

Here let me say a word about the art of "packing." Years ago everybody used the old Mexican saw-buck saddle, and it still bestrides the lacerated spines of unfortunate *burros*; but it has generally yielded place to the Californian stuffed aparejo, the shape of which is seen very well in the accompanying cuts. This is fastened firmly to the long-suffering beast, by all the strength of two men, who tighten the girth by bracing their feet against the upright

mule's ribs. Then a long lash-rope, having a broad, strong girth at one end, terminating in a wooden hook, is laid across the aparejo, and the packing begins. The burdens are laid on so as to balance properly, and are held in place until all, or the main part, is in position. Then the ends of the lash-rope are handed back and forth by the man on each side, twisted and looped loosely in a way very dexterous but utterly indescrib-

assembled. Foolishly, I ventured an opinion upon some subject, and, judging me by the clothes I wore, I was promptly snubbed.

"What right have you to know anything about it?" a big Klamath man hurled at me. "You're a tender-foot!"

"Perhaps I am," I answered, meekly; "but I can put the diamond hitch on a mule!"

"Can you do *that*? Then, sir, you are entitled to any opinion you please in this 'ere court!"

Even this lashing will not always hold firm, however, against equi-asinine contortions; but it is incomparably superior both for the welfare of the mule and the safety of the burden to the antiquated and cruel "saw-buck."

After sunset, the air in these high, western regions grows rapidly cool, and a chill air from the snow-banks seems to settle down and take possession of the warm nooks where the sunbeams have been playing all day. Now the long-caped, blue cavalry overcoats (bought in Denver or Cheyenne for three dollars apiece) are unstrapped from behind the saddles, fresh wood is

piled upon the fire, the pipes are newly filled, and the circling smoke, exploring the recesses of the dark tree-tops, looks down on an exceedingly contented company.

Then, as the fragrant herb glows in the pipe-bowl, and the darkness shuts in the fire and the little circle about it from the great Without, tongues are unloosed, and the treasures of memory are drawn upon to enliven the hour. All these mountain-men are great talkers, and most of them tell a story in a very vivid way—a way purely their own, sounding barbarous to other ears, so full is it of slang, local phrases, and profanity, but in a language perfectly understood and with a wit keenly appreciated by kindred listeners. Tales of Indian warfare and border ruffianism in the old days of the emigrant trail, the founding of the Mormon settlements, the track-laying of the Pacific railway and the gold discoveries; stories of the road agents—robbers of the mails and expresses, who never let a man out of the country with any money, and of the scarcely preferable vigilantes who sought to rid the mountains of these human wolves only to learn that the persons most trusted in their councils were the ring-leaders of crime. Between the road agents and the vigilantes no man was safe. The former might kill him to get him out of the



"GIVE IT TO HER."

able, and finally, by moderate pulling, the whole net-work is tightened. The load is now criticised and balanced anew, small articles are tucked in, and it is pronounced ready. One man goes to the left side of the animal and seizes a portion of the rope which passes round the hook, while the other, on the opposite side, turns his back and passes the end of the lash-rope over his shoulder so as to give him the greatest possible pulling power. This done, he calls back to his invisible mate:

"All set?"

"All set."

"Give it to her!"

There results a sudden and mighty strain in concert, a dreadful groan escapes from the poor mule, there is a stifled sound of creaking and crushing, and in an instant more the fastening is made and the work is done. This lashing is all one rope, but it is crossed and entwined till it seems half a dozen. On the top of the load it forms a rectangular or diamond shaped space, which gives the process its name among the packers. To know how to do it is a passport to mountain society and establishes credit. I remember once being alone at a little stage station in Wyoming. I had on a partially civilized coat and hat, and hence was under suspicion among the party of men

way, the latter might hang him on the single charge that the ruffians let him alone.

But the theme of all themes which is never neglected, and which lasts clear through the trip, is The Mule.

His mule is the mountain-man's mainstay. He treats it much more kindly than he does himself, and respects it far more than he does his neighbor. He finds all sorts of excuses for an habitual cut-throat; he simply *hangs* the mule-stealer.



A SENSATION.

The mountain-mule is a perpetual study. No animal in the world possesses so much individuality and will develop in a given time so many distinct phases of character. His sagacity in some directions is balanced by most desperate stupidity in others. A herd shows a wide range of variation in tractability and in other traits among its members. You cannot fail to note this in their different countenances, to which the long ears lend so much expression; but all their characteristics are positive, and are asserted in the most startling manner. They are crotchety, too, and it is often impossible to overcome their prejudices. One I knew who would never allow himself to be caught to have his pack put on or re-adjusted until all the rest had been attended to; then he was quite ready and docile. Another was a good, gentle riding animal, and had no objection to your pipe, but you must get off to light it; strike a match in the saddle and Satan entered into his breast on the instant. This same fellow had an insuperable objection to entering water,—an unfort-

unate trait, for before crossing an unknown stream with a pack-train it is desirable to know what sort of a ford it is, and the man who rode this mule was the one whose duty it generally was to make the test. The animal would walk straight down to the margin, then rear upon his hind-legs and spin round like a flash.

Fording a river, where the current is deep and rapid, is a dangerous experience for a pack-train. The attendants must ride on the lower side and keep the mules from drifting down-stream. They are very sure-footed and plucky under their loads so long as they keep up, but let one fall down, and there is not an instant to be lost if you would save him and his cargo. Leap into the water and help him up without an instant's delay, for if he gets any water in those big furry ears of his he will do nothing to save himself, but will lie there and drown without a struggle. Mules can swim very well, however, if they are willing to try. I once had one take me out of a very awkward predicament in that way.

All mules are very particular and private about their ears. They won't allow them to be touched or interfered with. These long and mobile members are very expressive in their various attitudes, but I could never learn satisfactorily what each position signified, unless it was that the next movement would be precisely the opposite of what was apparently intended. The paradox is the brute's model of mental action. Never was a mule more innocent in appearance than one which Mr. W. was quietly riding just ahead of me, one afternoon. I was half asleep, when I felt a smart blow on my stirrup. I thought a stone had been kicked up. A moment after the *tapadero* was struck, and I was just beginning to realize the truth, when I saw the heels of Mr. W.'s mule fly up. Probably nothing but a quick movement of my leg saved it from being broken. What caused that beast to kick at me three times without provocation? anything but "pure cussedness?"

Their tails, too, being very horse-like, are objects of great pride with them and they decidedly resent any fooling with them. The worst spell of kicking I ever saw, I think, was once when I accidentally struck backward with my three-lashed Indian *quist* and got one thong entangled in Darby's caudal extremity. Such a frightened and thoroughly indignant beast I never bestrode and hope never to again; but, in the expressive phrase of that hard-riding region I "stayed by him."

I had a mule once that would bray ferociously and incessantly whenever it was out of hearing of the train's bell. It was an excessively annoying habit, and, persuasion failing, I one day dug my spurs into its ribs, and hammered its head first with a strap, then with the butt of my pistol, every time the hideous voice was raised. I felt that there was no sense in the absurd practice, and I was bound to break it. But after an hour or two it was hard to keep my seat, for about once a minute the beast would duck its head and jump as though propelled from a cannon, uttering a terrible bray, apparently just to invite punishment. So I changed my tactics, and paid no attention whatever to the habit, and in a couple of days had no further annoyance. Mules know what disturbs you, and malignantly do that one thing regardless of pain to themselves. Another mule I had was an exemplar of this trait. He had a trick of swelling himself out when I put the saddle on, so that it was impossible to make the girth tight: I might as well have tried to draw in the waist of a steam-boat boiler, and to secure the saddle properly, I always had to catch him unawares, after we had got started.

It is not easy to gain a mule's confidence, and, on the other hand, he rarely merits yours. I have known one to carry his rider in the most exemplary manner for hundreds of miles, and then one morning begin a series of antics and develop an unruliness as uncomfortable as it was unexpected. Sometimes you can train them with considerable satisfaction, but you never feel quite sure of them. They are forever doing something surprising, heroically pulling through real difficulties to give up tamely before some sham obstacle. This is partly owing to their absurd timidity. If one scares, all the rest are panic-stricken. A piece of black wood, like the embers of an old fire, will cause almost any mule to shy. A boulder of a certain shape was invariably regarded with distrust by one I used to ride. Rattlesnakes they hold in just abhorrence; bears paralyze them with terror; Indians they cannot be spurred to approach. This excessive timidity is the result of their social habits. A mule cannot bear to be left alone, and although he knows he can go straight back from wherever you may take him, following the trail like a hound, yet he considers himself hopelessly lost and forlorn when he can no longer hear the bell. It is his use and habit to go with it. It means everything which makes life happy

for him, and he will endure very much punishment before forsaking it. However, two or three away together all day keep one another company and get along very well.

This attachment to the train, while it has been the salvation of many an outfit, becomes a great nuisance on the march. Mile after mile you plod along in the rear at a right-foot, left-foot, right-foot, left-foot jog which in the course of seven or eight hours wears out muscles and patience. The sun beats down, the dust rises up, and your only entertainment is the cow-bell hung on the neck of the leader. The first hour you do not mind it much; the second it grows wearisome; the third, painful, and you hold your ears to shut out the monotonous clangor; the fourth hour you go crazy—all life centers about that tireless hammering, and endless conning, till, in unison with the ceaseless copper-clatter of that ding-dong bell, your mind loses itself in

Hokey pokey winky wang,
Linkum lankum muscodang,
The Injun swore that he would hang
The man that couldn't keep warm.

You cannot get away from it. What is misery to you is melody to the mule, and if you try to ride him outside of the music of the bell, he may, perhaps, be made to go, but it will be in such a protesting, halting, lame and blind way, with such "uncertain steps and slow," turnings of reproachful eye and brayings of uplifted voice, that you will find it better to endure the evils of the pack-train than to attempt to escape from it. Of course, if you go clear away, out of sight and sound, the beast is obliged to content himself; but on the march this is not always pleasant or practicable.

But a diversion awaits. It is afternoon. Everybody is dozing. The distant line of trees which marks the day's destination is in sight, and the mules have been well-behaved all day. Plodding along in front of you at a rapid walk, very demurely, heads down, eyes half-closed, ears monotonously wagging, you think they have forgotten all their pranks, abandoned all intentions of wickedness concocted in the restful leisure of the early morning, and you fall into admiring contemplation of their exceeding docility and sweetness. Meanwhile, the aparejo and load of a certain little buckskin-hued Cayuse mule have been slipping backward, and he, knowing it, has made no sign, but has quietly wriggled and swelled himself until he has got far enough through the sinch to try his experiment. With the

suddenness and agility of a grasshopper he now gives a tremendous leap toward one side, bucks high in the air a dozen times in as many seconds, dancing about and kicking, stands straight up on his hind-legs, and falls over backward; next he squirms rapidly through the loosened girths until he can bring his heels to bear, and kicks boxes, bags and bundles until the saddle slips down over his legs and confines them like a handcuff. Then he rolls over and quietly nibbles the grass within reach, waiting, in the most exasperating unconcern, until you shall come and release him.

It will readily be understood that an eastern man finds the tricks and treachery, lively heels and diabolical disposition of the mule a constant check upon the enjoyment of western work and wandering. The mule-packers are the most desperately profane men I have ever met; they exhibit a real genius in "good mouth-filling oaths." Considering the vexation to which they are subjected, and which they must not otherwise retaliate, lest they should injure the precious endurance and carrying power upon which their lives depend, and which make mules far more valuable than horses for mountain service, it is not surprising. And though these strong and agile animals will stand for hours when the bridle-rein of one is merely thrown over the

ear of his neighbor, under the delusion that they are securely hobbled, they are very wise and cunning, and can doubtless talk among themselves; but it is an unfortunate fact that their wisdom is all exerted for wickedness, and their conversation used chiefly in plotting combined mischief. And it is my honest and serious opinion, founded upon much observation, that so long as any considerable numbers of mules are employed there, it is utterly useless for missionaries to go to the Rocky Mountains.



LABORING UNDER A DELUSION.

THE TORNADO.

WHOSE eye has marked his gendering? On his throne
 He dwells apart in roofless caves of air,
 Born of the stagnant, blown of the glassy heat
 O'er the still mere Sargasso. When the world
 Has fallen voluptuous, and the isles are grown
 So bold they cry, God sees not!—as a rare
 Sunflashing iceberg towers on high, and fleet
 As air-ships rise, by upward currents whirled,
 Even so the bane of lustful islanders
 Wings him aloft. And scarce a pinion stirs.

There gathering hues, he stoopeth down again,
 Down from the vault. Locks of the gold-tipped cloud
 Fly o'er his head; his eyes, Saint Elmo flames;
 His mouth, a surf on a red coral reef.
 Embroidered is his cloak of dark blue stain
 With lightning jags. Upon his pathway crowd
 Dull Shudder, wan-faced Quaking, Ghastly-dreams.
 And after these, in order near their chief,
 Start, Tremor, Faint-heart, Panic and Affray,
 Horror with blanching eyes, and limp Dismay

Unroll a gray-green carpet him before
 Swathed in thick foam: thereon adventuring, bark
 Need never hope to live; that yeasty pile
 Bears her no longer; to the mast-head plunged
 She writhes and groans, careens, and is no more.
 Now, prickt by fear, the man-devourer shark,
 Gale-breasting gull and whale that dreams no guile
 Till the sharp steel quite to the life has lunged,
 Before his pitiless, onward-hurling form
 Hurry toward land for shelter from the storm.

In vain. Tornado and his pursuivants,
 Whirlwind of giant bulk, and Water-spout,—
 The gruesome, tortuous devil-fish of rain,—
 O'ertake them on the shoals and leave them dead.
 Doomsday has come. Now men in speechless trance
 Glower unmoved upon the hideous rout,
 Or, shrieking, fly to holes, or yet complain
 One moment to that lordly face of dread
 Before he quits the mountain of his wave
 And strews for all impartially their grave.

And as in court-yard corners on the wind
 Sweep the loose straws, houses and stately trees
 Whirl in a vortex. His unswerving tread
 Winnows the isle bare as a thresher's floor.
 His eyes are fixed; he looks not once behind,
 But at his back fall silence and the breeze.
 Scarce is he come, the lovely wraith is sped.
 Ashamed the lightning shuts its purple door,
 And heaven still knows the robes of gold and dun
 While placid Ruin gently greets the sun.

TOPICS OF THE TIME.

A Lay Sermon for Easter.

IN a Christian nation, no "topic" could be more appropriate to the Easter "time" than the resurrection from the dead of the founder of Christianity; and there is a single aspect of this event which it seems proper for us to present. It is particularly appropriate for a secular press to do this, because the secular press has had so much to do with the upsetting of the faith of the world in this most significant event—an event on which the authorities of Christianity make the religion of Christ to depend. If Christ be not raised, these authorities declare that the faith in him is vain, and his followers are yet in their sins. It is a curious and most noteworthy thing, after all the dogmas that have been reared upon the death and sacrifice of Christ, that the one only essential fact of his history—essential to the establishment of his religion, without which everything else would be of no account—is declared to be his resurrection. It was not enough that he died; it was not enough that he suffered—all this was of no account

whatever, as compared with his rising again. His death did not wipe out the sins of his people; if he did not rise, they were still unforgiven.

There probably never existed a more fearfully demoralized set of men than the disciples and followers of Jesus Christ on the night of his betrayal and arrest. One betrayed him, another denied him, and all forsook him and fled. They had been with him during his wonder-working; they had heard him talk of his kingdom; some of them had been with him on the Mount of Transfiguration; they had seen unclean spirits subject to him; they had seen life restored at his touch and disease banished by his word; he had grown before them into a great, divine personage, armed with all power and clothed with all grace. They had forsaken homes and friends and pursuits to follow him, with great, indefinite hopes and anticipations that it was he who should redeem Israel, but without any intelligent estimate of his mission; and when they saw him in the hands of his enemies, and apparently helpless, a great panic seized them, and they literally gave him

up, with all the schemes engendered by their intercourse with him.

This, however, was but the beginning of the tragedy. Calvary with its cross stood directly before them, and the infamy and cruelty of his death were consummated there amid such convulsions of nature as might well signalize one of the most shameful events in the history of human injustice and crime. The great religious teacher and inspirer had died the death of a malefactor, hanging between two thieves. He had manifested none of the power which he claimed, though taunted by the mob and called upon to save himself if he indeed were the person he claimed to be. After he was found to be dead, Joseph of Arimathea took down his lifeless body and buried it. A stone was rolled to the door of the sepulcher and sealed, and the disciples were in hiding. They were undoubtedly in deep sorrow, for they had loved the Master and had built great hopes upon him. But during those three days after his burial, the Christian religion was as dead as the person who had undertaken to found it. Every hope of his followers was buried in that sepulcher, and not one of all their hopes would ever have revived had he not come out of it. And this is the thought that we wish to present to-day, viz.: that the fact that Christianity, as a living and aggressive religion, exists at this moment, is proof positive that Christ rose from the dead. It never would have started, it never could have started, except in the fact of Christ's resurrection. The story of his disappearance from the tomb and his re-appearance among his disciples is familiar to all. These events have formed the themes of painter and poet through eighteen hundred years of art and song. The story was as incredible to the disciples as it is to the skepticism of to-day; but they saw him, they heard him talk, he came and went among them, appeared and disappeared at will, gave them his message and their mission, and was at last received up out of sight, having promised to be with them even unto the end of the world. Paul, in writing to the Corinthians, says he was seen by Cephas, then by the twelve, after that by above five hundred brethren at once, most of whom were living at the time he was writing his letter. After that he was seen by James, then by all the apostles again, and at last by Paul, himself. It was because it was supported by all this throng of witnesses, whose word could not be gainsaid, that the Christian religion established itself. Not only was Christ indorsed as a divine and authoritative personage, but the immortality of the soul was demonstrated. What wonder is it that these men were ready to die in their devotion to the Master, whom they had seen conquering death, and whom they had known as an immortal leader?

So we say that there is no better evidence that Christ rose from the dead than the present existence of his church in the world. It never could have been founded with Christ in the tomb. It never could have been founded on imperfect testimony. These men knew what they had seen, what their hands had handled, and what they were talking about. It really was not a matter of faith with them at all. It was a matter of fact, lying indestructibly in

their memories, and vitalizing all their lives. In the tremendous enthusiasm, born of this burning memory, Christianity had its birth. In the faith of this great initial and essential fact, Christianity has been propagated. It is the only open demonstration of the problem of immortality ever vouchsafed to the human race, and it is part and parcel of the Gospel which Christ commanded should be preached to every creature, with lips already clothed with the authority and with voice already attuned to the harmonies of the immortal life. The facts of the resurrection of Christ and the immortality of the soul find their highest, nay, their overwhelmingly convincing testimony in the birth and continued existence of the Christian religion. There is no man living who can form a rational theory of the genesis and development of Christianity who does not embrace the resurrection as an initial and essential factor. A living religion never could have been founded on a dead Christ, and it is safe to say that the religion that rests upon a living Christ can never be superseded or destroyed.

A Profitable Art Industry.

AN OFFER OF PREMIUMS.

ONE of the sad things—almost the only sad thing—connected with the tremendous popular interest in art that has been developed in America within the last few years, is that there are multitudes engaged in its study with the utterly futile hope that in some way they can make it a source of livelihood to them. How many women there are at this moment painting porcelain, and dreaming of returns, who will never realize a penny from their enterprise, the public will never know, but the number is very large. The young men and young women in the various art-schools, learning to draw, are most of them looking forward to a life of remunerative art-work which will never be accomplished. Lacking invention, genius, originality, they will not be able to produce pictures that will sell, and they will be much disappointed.

The marvel to us is that so few, in the presence of notorious facts suggesting opposite action, should think of becoming engravers upon wood. The busiest people we know of in the United States are wood-engravers. We do not know of one who has not all he can do, and more, too. Every good engraver is busy up to the measure of his strength and endurance, and even the commonplace and poor engravers have their hands full of commonplace and poor work, of which there is an enormous amount done in this country. There is a vast field for this latter work in all sorts of illustrated catalogues, and second and third rate periodicals; and the field promises to become larger rather than smaller. We feel that art-schools themselves are much at fault in not providing facilities for teaching this branch of art-work, and the very first thing for them to do is to establish classes in wood-engraving under the charge of competent masters. There is no question that a good engraver on wood can get a good living. There is a good deal of question as to

whether an excellent painter or sculptor can get his bread by his work. Pictures are luxuries, while engravings are in the line of great business enterprises that demand and must have them.

There is a prejudice among artistically inclined people against the work of the engraver. It is widely regarded as pretty purely mechanical, but, in these days, it takes an artist to engrave, and men can make great reputations in the art-world as engravers. Mr. Linton, Mr. Anthony, Mr. Cole and Mr. Marsh are eminent men—men as well and favorably known as the best of our artists, and known for the same reason, viz. : that they are artists.

In order to attract attention to this most important field of art-work, we have concluded to offer three premiums to pupils for the best work as follows: \$100, \$75, and \$50, respectively, to the first, second and third best specimens of wood-engraving, produced and sent to this office any time during the present year, 1880, by pupils in any art-school or

under any private teacher in the United States. We shall need to see only proofs, accompanied by the teacher's certificate that the competitor submitting them is in reality a pupil who has never done engraving for the public or for pay.

We propose, as the board of judges, Mr. Alexander W. Drake, superintendent of the department of illustration in SCRIBNER'S MONTHLY and ST. NICHOLAS, Mr. Timothy Cole, a practical engraver of the first rank, and Mr. Theodore L. De Vinne, who is probably the best printer of wood-engravings in the United States. We can assure all competitors that they will have at the hands of this board competent and fair treatment. Its decision will be rendered January 1st, 1881, and the awards will be promptly made. In case any pupil wishing to compete has really done unimportant work for pay, he or she shall send proofs of it, and the judges shall decide at discretion whether it is important enough to vitiate the claim to be considered still a pupil.

COMMUNICATIONS.

The First Breech-loading Rifle.

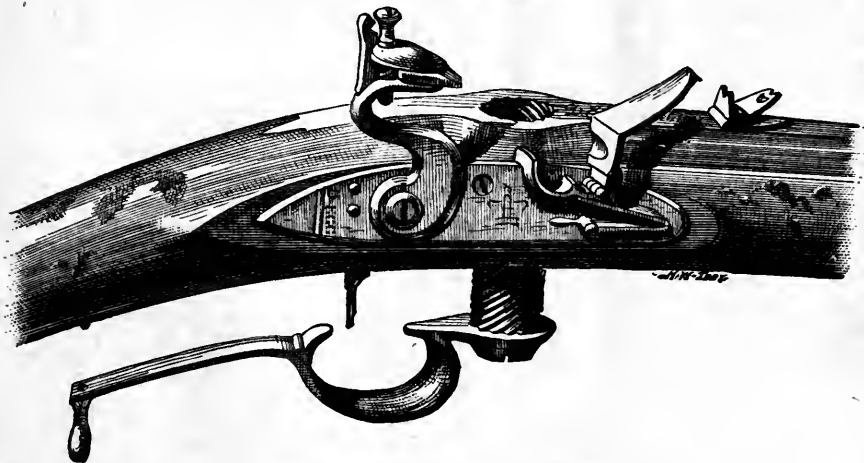

BREECH PIECE OF THE FERGUSON RIFLE.

EDITOR SCRIBNER'S MONTHLY. Sir: It has occurred to me, upon seeing Colonel Church's paper on "American Arms and Ammunition" in your January number (1880), that many of your readers would be interested in a short account of the first breech-loading rifle ever used by regularly organized troops in actual conflict, the only specimen of which—except, perhaps, another in the Tower of London—is in my possession, as fit for service to-day as when made, over a century ago, by the famous Egg, of London.

This arm was invented, some time previous to 1776, by Patrick Ferguson, Junior, major 2d Bat., 71st Regt. Highlanders, who was highly distinguished not only for military abilities of every order but for skill as a marksman and extraordinary pre-science as an inventor. "He was, perhaps, the best professional marksman living, and probably [at the

period of our Revolutionary War] brought the art of rifle shooting to the highest point of perfection." Although he only served in the American war subsequent to 1777, he rapidly acquired the confidence of his successive commanders by his activity, resolution, chivalry, capacity and loyalty. As a partisan, and in the conduct of "*la petite guerre*," he was without a superior in the British army. The first allusion to this fire-arm is in the "Annual Register" of 1776, June 1st, page 148. In the second part of the same volume, pages 131, 132, etc., its distinguishing feature is referred to in an article entitled "The Effects of Rifling Gun-barrels." This article also contains the first recommendation of oblong bullets as superior to round ones, an improvement not carried into effect until within a very few years.

The drawings of Ferguson's invention, as applied to a breech-loading rifle, likewise of his other invention for breech-loading cannon, are to be found in Volume 1,139 of English Patents, the text of which is on the lower shelf of Alcove 132, in the Astor Library.

"To explain its peculiarities a few details are necessary. The length of the piece itself is 50 inches [of a U. S. rifle 48 $\frac{3}{4}$ inches]; weight, 7 $\frac{1}{2}$ lbs. [of a U. S. rifle, 1850, 9 $\frac{1}{2}$ lbs.]. The bayonet is 25 inches in length [a U. S. musket bayonet blade being 16 inches], and 1 $\frac{1}{2}$ inches wide, and is what is commonly called a sword-blade bayonet; flat, lithé, yet strong, of fine temper, and capable of receiving a razor edge, and when unfixéd as serviceable as the best balanced cut-and-thrust sword. The sight at the breech is so arranged that by elevating it is equally adapted to ranges ranging from 100 to 500 yards. Its greatest curiosity is, namely, the arrangement for the loading at the breech. The guard plate which protects the trigger is held in its position by a spring at the end nearest the butt. Released from this spring and thrown around by the front, so as to make a complete revolution, a round plug descends from the barrel, leaving a cavity in the upper side of the barrel sufficient for the insertion of a ball and cartridge, or loose charge. This plug, an accelerating screw, is furnished with twelve threads to the inch, thereby enabling it, by the one revolution, to open or close the orifice; so that the rifle is thereby rendered capable of being discharged seven times a minute. This accelerating screw constitutes the breech of the piece, only instead of being horizontal, as is usually the case, it is vertical. Were there not twelve independent threads to this screw it would require several revolutions to close the orifice, whereas one suffices."

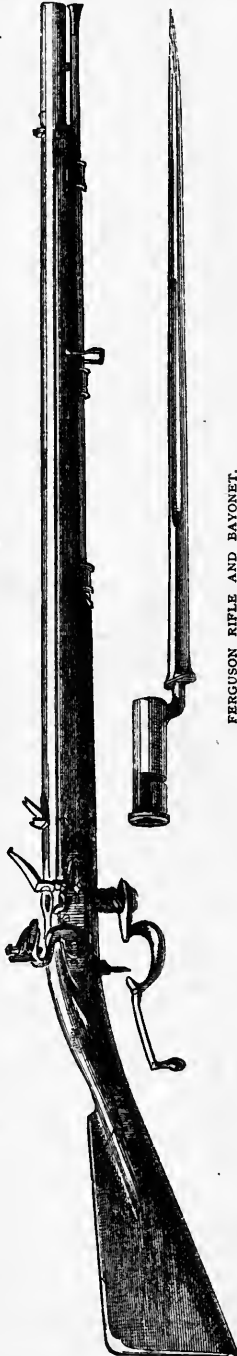

FERGUSON RIFLE AND BAYONET.

In Bissett's "History of the Reign of George III." (London, 1803), vol. ii., pages 423-4, is the first mention of the service of British troops armed with this rifle, at the battle on the Brandywine, Sept. 11, 1777. The marginal reference reads: "Major Ferguson essays a new species of rifle, invented by himself;" and the account reads:

"At the same time General Knypphausen, with another division, marched to Chad's Ford [on the Brandywine] against the provincials who were placed there; in this service the German experienced very important assistance from a corps of rifle-men, commanded by Major Patrick Ferguson. The dexterity of the provincials as marksmen had been frequently quoted, and held out as an object of terror to the British troops. Ferguson, a man of genius, which was exercised in professional attainments, invented a new species of rifle, that combined unprecedented quickness of repetition with certainty of effect, and security to the soldiers. The invention being not only approved, but highly admired, its author was appointed to form and train a corps for the purpose of practice; but an opportunity did not offer of calling their skill into action, until the period at which we are now arrived. Ferguson, with his corps, supported by Wemyss's American Rangers, was appointed to cover the front of Knypphausen's troops, and scoured the ground so effectually that there was not a shot fired by the Americans to annoy the column in its march."

It is said that but for the magnanimity of Ferguson, General Washington would have lost his life during this engagement.

In a rare old book, Osbaldiston's "Universal Sportsman; or Nobleman, Gentleman, and Farmer's Dictionary" (Dublin, 1792), which came by accident into my possession, the method of charging this breech-loader is thus described in an article on "Shooting,"—page 562:

"By far the most expeditious way of charging rifed pieces, however, is by means of an ingenious contrivance, which now generally goes under the name of *Ferguson's rifle-barrel*, from its having been employed by Major Ferguson's corps of riflemen during the last American war. In these pieces, there is an opening on the upper part of the barrel, and close to the breech, which is large enough to admit the ball. This opening is filled by a rising screw which passes up from the lower side of the barrel, and has its thread cut with so little obliquity, that when screwed up close, a half turn sinks the top of it down to a level with the lower side of the caliber. The ball, being put into the opening above, runs forward a little way; the powder is then poured in so as to fill up the remainder of the cavity, and a half-round turn brings the screw up again, cuts off any superfluous powder, and closes up the opening through which the ball and powder were put. The chamber where the charge is lodged is without rifles, and somewhat wider than the rest of the bore, so as to admit a ball that will not pass out of the barrel without taking on the figure of the rifles, and acquiring the rotary motion when discharged."

Ferguson, when only a captain, was intrusted with the leadership of several important operations. In September-October, 1778, he commanded the

expedition against Little Egg Harbor, New Jersey, so disastrous to the American privateers and to Pulaski's Legion. In 1779, when the British re-occupied Stony Point, a few days after its capture by Wayne, July 15-16th, 1779, Ferguson was selected as the commandant of the new garrison. When Sir Henry Clinton went South in December, 1779, to capture Charleston, he took Ferguson with him. In the subsequent siege the Major displayed unusual energy, capacity and magnanimity.

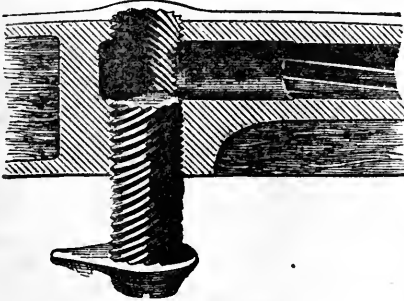

SECTION OF BREECH.

When Clinton returned in the summer of 1780, he left Cornwallis in command at the South, to whom Ferguson with his partisans, and Tarleton with his dragoons, became respectively right and left hand in the campaign to complete the subjugation of the Carolinas. Major Ferguson, as Lieutenant-Colonel in the line, styled by courtesy "colonel," with the "local" rank of Brigadier-General, was detached to organize the loyalists in N. W. South Carolina, and S. W. North Carolina.

In this expedition, in which he lost his life, Ferguson was accompanied by his favorite pupil, a Captain of the Loyal Regiment, known as the New York Volunteers. This officer, only twenty-two years old, was detached, previous to the fatal battle of King's Mountain, to assist in hunting the colonial Colonel Clarke out of South Carolina, and by his assignment to this duty escaped the fate of his superior officer. The particular rifle under consideration was a present to him from its inventor, his patron and friend. From him, it passed into my possession from my grandfather through the hands of his youngest surviving son, now President of the New York Historical Society. Yours respectfully,
J. WATTS DE PEYSTER.

HOME AND SOCIETY.

Operas for Amateurs.

SINCE the anchorage of the most popular of Her Majesty's ships within the hospitable harbor of the American stage, every one who thought he could pen a note of musical comedy has made the attempt, and those who have not resorted to their own talents have searched the repertoire of other countries for music of that sort. The result has been numerous importations and revivals, which have been presented with more or less success. As the music of most of these operas is simple and the librettos, as a general thing, harmless, they are very well adapted to the use of amateurs. Take, for example, "The Doctor of Alcantara," the music by Mr. Julius Eichberg and the libretto by Mr. B. E. Woolf, both of Boston. Oliver Ditson & Co. have just published a "new enlarged and revised" edition of this opera, which has been having a successful run in London and Boston. The music is sparkling and pretty, and the libretto is amusing. The setting of the opera is so simple that it can be performed even when the contents of the property-room are of the most limited order. I remember seeing it given once with excellent effect in a back parlor, the audience being seated in the front room. To be sure it was something like playing on a dinner-table, but the performers did not mind that, and if *Don Pomposo* did knock the chandelier with his staff once or twice it only made his acting seem the funnier, and doubtless passed as part of the business of the piece. I have heard this opera sung half a dozen times, and always by amateurs,—sometimes in a real theater with an orchestra to play

the music, and at other times with a piano and parlor organ, which, when played together, have very much the effect of brass and string instruments. "The Doctor of Alcantara" is in two acts, and requires nine soloists and a chorus, though the latter has very little to do. The scene of the opera is laid in Spain, and the story is that of a young girl who is betrothed by her father to a young man whom she has never seen. She hates this forced lover, and falls madly in love with *Carlos*, "another" who sings sweet songs under her window. *Carlos* bribes *Inez*, confidential maid to *Isabella*, the young lady in question, to get him into the house that he may talk with his inamorata undisturbed. He is carried there in a hamper, from which he escapes, and then conceals himself. *Isabella's* father, *Doctor Paracelsus*, finding the hamper in his office, wishes to get it away before his nagging wife sees it, so he tips it out of the window over the balcony into the river below. Subsequently he learns that there was a man in it, and is terrified lest he has committed murder. While he is grieving *Carlos* appears and announces himself as the son of *Señor Balthazar*, and, consequently, the young man destined for *Isabella*. The dear old *Doctor* is so glad to see him that he opens a bottle of wine, which proves to be a narcotic, and *Carlos* falls into a deep sleep. The *Doctor*, thinking that he has poisoned the son of his old friend, is completely crushed by the committal of another murder, and hides the body of his second victim under the sofa in his room. About this time *Señor Balthazar* arrives, and the *Doctor's* house being small, the sofa is assigned to him for a bed. In the

dead of night *Carlos* recovers and crawls out from under the sofa. There is an encounter in the dark, lights are lit, friends and neighbors rush in and a general explanation ensues. The plot is full of action and comical situations. The setting of both acts is the same: a room, plainly furnished, with a large window in the center; a cabinet of drugs against the wall, a table, a sofa high enough for a man to crawl under, and a few chairs. The costumes are simple enough. The *Doctor* generally wears a dressing-gown; the other men wear Spanish costumes of a century ago, and the women appear in short, gay-colored skirts, high combs, and Spanish veils. A little research in illustrated books and in closets and a little feminine ingenuity will provide these without much difficulty.

One of the jolliest little pieces for stage or drawing-room is "Cups and Saucers," a "satirical musical sketch," in one act, by Mr. George Grossmith, Jr. Mr. Grossmith is one of the cleverest young actors in England. He was the original *Sir Joseph Porter* and has played that part for over five hundred nights. He is also the author of a musical monologue called "Eyes and Ears in London," which Miss Kate Field is to produce in America before long. There are only two characters in "Cups and Saucers," *Mrs. Nankeen Worcester*, "a china maniac," and *General Deelah*, "another." *Mrs. Worcester* dresses in fashionable widow's attire, and the *General* in evening dress. The scene is a drawing-room with handsome furniture, a piano at left and a five o'clock tea-table in the center, with tea-things. The music of this little piece is very pretty, the duet "Foo Choo Chan" being unusually ear-catching. I believe that Mr. Grossmith wrote "Cups and Saucers" expressly to be played before "Pinafore," for they like a good long bill in London. At any rate, that is the purpose it served, and it met with great favor.

Mr. J. R. Thomas's "Diamond Cut Diamond" was written with special reference to amateurs, and, like "Cups and Saucers," is in one act, and, also like that piece has but two characters. It is not, however, to be compared with Mr. Grossmith's satire for brightness of dialogue. The action takes place in the parlor of a hotel. The characters represented are *Clara*, soprano, and *Charles*, tenor. The dress of the former is a ball-room costume with mask, and a maid-servant's dress as a disguise. *Charles* has three changes: a dress-suit, an Irish servant's dress with comic wig, and a gondolier's suit,—which may be made of a water-proof cloak,—knee-breeches, and slouch hat. "Knee-breeches" sounds formidable, but these can be made very readily by cutting off the fore-legs of a pair of old trowsers and pulling on a pair of long stockings. The personator of this character should wear low shoes, unless he wants to be taken for a "pedestrian." In what are called "shape" plays, amateurs in the country are often put to it for "tights." Kings, and even courtiers, find it necessary to wear this article of apparel, which is the most expensive part of the costume, often costing as much as \$20 a pair, when of silk. For \$1.50 or \$2.00, however, one can get long leggings

that reach to the waist and at a short distance pass for very respectable tights.

Ambitious amateurs who may desire something more difficult than either of these operas will find "The Bells of Corneville" worthy their attention. The music is exceedingly pretty, and there is an opportunity for the display of more histrionic ability than is necessary in the operas I have mentioned.

Amateurs, as well as the general public, owe a heavy debt to Messrs. Gilbert and Sullivan for what they have done to popularize wholesome comic opera. The mysteries of "that infernal nonsense, 'Pinafore,'" to quote from *Major-General Stanley*, have long since been explained in this department. There are, however, other operas by these authors that are in every way worthy the consideration of amateurs. First among them is "The Sorcerer." This sparkling and witty opera was performed at the old Broadway Theater last winter, but was so badly done that it can hardly be said to have been done at all. Some of the music of the piece is quite as good, if not better, than "Pinafore," and its elements of popularity are almost as many. The *Sorcerer* is *John Wellington Wells*, a "dealer in magic and spells," who sells a potion which, when taken, makes the one who drinks it fall madly in love with the first man or woman he or she happens to meet. The situations that arise from this potion-drinking are extremely comical, yet the piece, like "Pinafore," must be acted with perfect seriousness. It is written in two acts, and there are ten characters besides the chorus. The scene is laid in England and the time is the present. Both scenes are out-of-doors, but if the amateurs have the use of a theater they will find little trouble in setting them. The costumes are not difficult to arrange, if one remembers that paper-muslin makes excellent silk or satin, and that cotton-flannel, which may be bought in a great variety of colors, will do excellent duty as velvet.

"Trial by Jury," by the same composers, is well suited to parlor performance. The scenery is easily managed, and the costumes are of the present day. The dialogue is extremely funny, and the music attractive.

All of the foregoing operas are published by Oliver Ditson & Co., Boston, or C. H. Ditson & Co., N. Y.

It will be a long time before "The Pirates of Penzance" will be accessible to amateurs, for neither the words nor the music are published yet, nor are they likely to be. It would be a difficult opera to produce, as the scenery of the second act could only be set on a real stage by expert carpenters and scene-shifters. Moreover, the music is difficult. Few amateurs could do justice to the whispering chorus of the first act or to many of the solos of the second.

In this connection the "Frog Opera" should not be forgotten. It is quite popular among amateurs. The libretto is by Mr. Charles J. Miller, and the music is selected from various sources. Part of the performers dress as frogs, and the effect is said to be very amusing. I have not seen this opera, though it was performed in Brooklyn quite recently.

M. L. E.

CULTURE AND PROGRESS.

James's "Hawthorne." *

WHEN it is a writer's purpose to sketch the life of a great literary man, it is not enough that he should do his best. The task is peculiar in this way, that nearly every one who reads the biography has formed his opinion of the subject beforehand. In the case of Hawthorne an additional complication ensues from the fact that so few sketches of his life have been written that his character has not yet become as it were common property for the critics to air their private conceptions upon. On the one hand Mr. James has to encounter—in this country, at least—minds made up on the subject, and on the other he is sure to meet with rebuff if he treats the matter off-hand. In one sense Mr. James's treatment of Hawthorne is far from off-hand. Here, as elsewhere, he is the same careful workman, fastidious as to his phrases and quite as self-conscious as any of the New Englanders upon whom he throws the slur. So, although as workman he has done his best, it does not follow that his best is appropriate to just the thing he has undertaken. Delicate as many of his criticisms are, and admirable as is the discrimination which separates the finer from the less excellent productions of Hawthorne, it is apparent from the first page that Mr. James lacks the underlying characteristic which a good biographer must have, namely, sympathy.

Mr. James shows no sympathy whatever with the United States, New England or Hawthorne. It is not now his fault; it has become his misfortune. Hence we see the curious spectacle of a writer brought up in New England and having imbibed the ideas, character and even phraseology of New England people, not only treating that section of the country with contempt, but unable to rise to a sympathetic appreciation of her most exquisite literary product. That he should have learned to abhor the narrowness and priggism so often associated with Boston is not much to be surprised at, but that he could maintain a frigid attitude toward Hawthorne is singular indeed. Verily, there is a narrowness of the cosmopolite as well as of the provincial.

The spirit of the book, therefore, not the letter, is what is deprecated. The study is full of good things, well considered opinions; moreover, these are admirable without respect to the odd mixture of French persiflage and English insolence which gives the study its general tone. For instance, in partial accord with Emile Montégut, but also with strong divergence, Mr. James puts his hand on the dominant chord of Hawthorne's mind as follows:

"This is the real charm of Hawthorne's writing—this purity and spontaneity and naturalness of fancy. For the rest, it is interesting to see how it borrowed a particular color from the other faculties that lay near it—how the imagination in this capital son of

the old Puritans reflected the hue of the more purely moral part of the dusky, overshadowed conscience. The conscience, by no fault of its own, in every genuine offshoot of that somber lineage, lay under the shadow of the sense of sin. This darkening cloud was no essential part of the nature of the individual; it stood fixed in the general moral heaven under which he grew up and looked at life. It projected from above, from outside, a black patch over his spirit, and it was for him to do what he could with the black patch. There were all sorts of possible ways of dealing with it; they depended upon the personal temperament. Some natures would let it lie as it fell, and contrive to be tolerably comfortable beneath it. Others would groan and sweat and suffer; but the dusky blight would remain, and their lives would be lives of misery. Here and there an individual, irritated beyond endurance, would throw it off in anger, plunging probably into what would be deemed deeper abysses of depravity. Hawthorne's way was the best; for he contrived, by an exquisite process best known to himself, to transmute this heavy moral burden into the very substance of the imagination, to make it evaporate in the light and charming fumes of artistic production. But Hawthorne, of course, was exceptionally fortunate; he had his genius to help him. Nothing is more curious and interesting than this almost exclusively imported character of the sense of sin in Hawthorne's mind; it seems to exist there merely for an artistic or literary purpose. He had ample cognizance of the Puritan conscience; it was his natural heritage; it was reproduced in him; looking into his soul, he found it there. But his relation to it was only, as one may say, intellectual; it was not moral and theological. He played with it, and used it as a pigment; he treated it, as the metaphysicians say, objectively."

Passages like this redeem the study; but it must be acknowledged that on the whole Mr. James, far from approaching the subject with proper reverence, saunters up to Hawthorne with his hands in his pockets and begins to criticise both the genius and his birthplace with the air we see too often in our friends whose traveling has been more extensive than their thoughts have been profound. Has Mr. James described the floating American population of Europe so long that he has ended in becoming assimilated to the types in his novels? It is certain that the essay is pervaded with something very like a most detestable practice of Americans abroad, consisting in a species of self-conscious apology for the peculiarities of life in America, an uneasy depreciation of things American, because European ill-will is felt before it is uttered. Mr. James has described, in his own excellent way, persons who err after this common fashion. For fear of incurring the charge of native hero-worship, has he gone to the other extreme and entered into the other affectation of cynicism? Or is he merely striving to put himself in the place of his English audience, when he adopts the superior, condescending tone of insulars, justly infuriating to reasonable men of other nations?

Whatever answer is made to these natural ques-

* Hawthorne. By Henry James, Jr. "English Men of Letters." Edited by John Morley. London: Macmillan & Co. New York: Harper & Brothers. 1880.

tions, it cannot be greatly to the credit of Mr. James as a thinker of breadth and force. It might seem that a more liberal soul would find in the episode of the evening passed at the Peabody house over a bookful of Flaxman's attenuated outlines nothing to give rise to a covert sneer, but rather a source of admiration that from such unpromising surroundings anything great should come. Notwithstanding Hawthorne's remark in the preface to "The Marble Faun," as to the connection between ruins and romance, Mr. James's belief that ivied ruins and such things are necessary to literary growth is astonishingly crude, when emanating from a man so discriminating and observant as he. It is on a par with the vulgar modern painters of France, who, through all the glamour produced by extraordinary technical ability, show the triviality of their natures by surrounding themselves with studios full of bric-à-brac especially arranged to dazzle the reporters for the daily press.

Indeed Mr. James is sadly deficient in the true artistic sense, even when shown in a literary phase. The Hawthorne theory of ruins he carries out into commonplace. He gives quotations from Hawthorne's Note-Books (at the same time making clever and true criticism on the general relation of these Note-Books to Hawthorne and the world), which defeat in themselves the argument for which they are quoted. To a true artist, such as Hawthorne was, the "trifles" quoted are not trifles. "The aromatic odor of peat-smoke in the sunny autumnal air is very pleasant"—Mr. James cannot understand of what use that was. Of course it spoke to Hawthorne of a whole picture, just as an incomprehensible jumble of strokes in an artist's note-book is seen by him to represent a landscape. At the same time it may be true that the Note-Books are self-conscious. But people in glass houses should not throw stones.

Julian Hawthorne's "Sebastian Strome."*

It is Mr. Hawthorne's fate that comparisons are always instituted between his own work and that of his illustrious father. Nor is it any more his fault, or any less his misfortune, that there is some shadowy basis for the comparison. Even in "Sebastian Strome," which differs materially and delightfully from "Bressant" and "Garth," there is a reminiscence of Nathaniel Hawthorne, and singularly to say, of one of his greatest works, that on which his fame was founded, and which, it may safely be said, he never surpassed. Sebastian Strome, the chief actor in this new story, is obviously like the young minister in "The Scarlet Letter," for he, too, although preparing for the ministry, has the same terrible secret to conceal. Yet, though the plots in their most general terms are similar, the unlikeness otherwise could not well be greater. It is not merely that the epochs are different, Strome being the son of an English curate of to-day; the spirit in which father and son have

treated an analogous theme is as far asunder as the poles. Nathaniel Hawthorne belongs to the idealists; his son to the realists. While one represents the cold but lofty speculations of the beginning of this century which found greatest expression in New England, both in literature and sculpture, the other adheres to modern Positivism and Realism, or say even to Impressionism, that off-shoot and partial protest against both the others.

Characteristic of the two epochs and the two men as seen in their work are the different modes of coming before the public. Nathaniel worked many years against discouragement and neglect; Julian has the press and the public on his side from the start. The elder seems to have warmed slowly and thoroughly to his profession; the younger begins life by boiling over at once, producing short stories and novels that in spite of their virtues are conspicuous for faults of excess. Nathaniel required, if he required anything, encouragement and knowledge of life, travel, sympathy, excitement. Julian needed discouragement, hard work, rebuffs and neglect. The father got what he needed later in life, but we may hope that the son has passed the age where hard treatment will be longer necessary. "Sebastian Strome" has many indications that he has learned of his own accord how to prune away the faults of his former style.

In "Sebastian Strome" we find Mr. Hawthorne dealing with some of the problems proposed in "Daniel Deronda," but purposely dealing with them, and taking views entirely different from those of George Eliot. He seems to have felt a natural distaste for the improbable character of that last hero of the great English novelist; perhaps his temperament rebels more than another's at what may seem to him the girlish inadequacy of Daniel Deronda. Or it may be that the mere idealism of that character runs so counter to his own views of life that he could not help this protest. For "Sebastian Strome" is a protest against Daniel Deronda and many other charming ideals. The work begins by showing us the beautiful life of Sebastian's father and mother in the parsonage; then we scent a crime in the person of pretty, naughty Fanny Jackson; then we are sure that while the father and mother are thinking of their son as one of the elect, that son has given himself to the devil in most of the shapes in which he appears to young men. Another protest against Daniel Deronda is Selim Fawley, the unctuous young English Jew who carries off Mary Dene, the heiress. Has Mr. Hawthorne imbibed in Germany a hatred of Jews, or is this merely a literary protest against George Eliot's fiction? At any rate, Selim Fawley, besides being personally obnoxious, is a scoundrelly wretch,—writing anonymous letters, intriguing to get the heiress more for money and his own comfort than love, driving bargains with a vulgar Yankee, and forming a "pool" to make money out of the needs of the English soldiers during the Crimean war. When this oily young banker does finally get Mary Dene to wife, he is physically in the condition of

* Sebastian Strome. A Novel. By Julian Hawthorne, author of "Garth," etc. New-York: D. Appleton & Co.

Casaubon, the decrepit husband of Dorothea, in "Middlemarch." Mary Dene may be called a protest against both Dorothea and Gwendolen; and if she be not so carefully finished and rounded a character as either of these women, it is quite certain that she is conceived on a larger scale, more attractive to both men and women,—in fine, is a more heroic heroine. What surprises the reader of Mr. Hawthorne's books more than anything else, is the faculty he has discovered of representing lovely characters of women side by side with the most repulsive types of men. Mary Dene has the tenderness and home-loving qualities of the best English girls, joined to the dash and *spirituelle* charm of American women. She is so fine a character that readers will have no patience with the gross and vindictive young hero whose utter selfishness wrecks the early years of her life.

It may be that "Sebastian Strome" is only a novel of the day and will be forgotten when the books of Nathaniel Hawthorne and George Eliot are still read with delight. But this much is sure: there is no escape for the reader on whom the story has once taken hold. It may be horrible, but it holds the attention like a vise. It abounds in ideas, new views of daily matters, bold and original declarations that feeble folk slur over as best they can. The author is possessed with a fury of truth, and makes truth almost the only virtue in his hero. Everything must be said outright. The book still bears traces of an overweening confidence in himself, and of his iconoclastic desires. It is still Gothic, but it is masculine. It sets the pulses to beating and fills the eyes with tears. Strangely enough, the three chief actors, in turn, become partially insane for brief periods and their crazy moments are conscientiously described. Altogether "Sebastian Strome" may be called meat for strong men, not milk for babes.

Austin Dobson's Poems.*

If gravity of intention be a characteristic of the English mind, as Taine maintains with such pertinacity in his "History of English Literature," it is not its only, nor its strongest, characteristic, for it is always accompanied by a sense of humor which heightens it by contrast, and brings it within the range of sympathies which it would otherwise repel. All the great English poets, with the exception of Milton, were distinguished by their comic as well as their tragic power—Chaucer as much by the *Wife of Bath* as by *Patient Grissell*, and Shakspeare as much by *Bottom* and *Dogberry* as by *Hamlet* and *Lear*. The lesser poets had less of it, and required less of it, in the work to which they devoted themselves. It would have been out of place, for example, in the serious narratives of the Elizabethan poets, and equally out of place in the love-verses of their successors. The best of the latter were not entirely without it, however, as the readers of

Cowley's "Chronicle" and Suckling's "Ballad upon a Wedding" will remember. There is a lightness, a grace, a jovialty about this last piece which separates it from all the poetry of its time, and which would make it perfect if it were not unfortunately smirched with coarseness and indelicacy. The element of humor in one form or another was conspicuous, though not abundant, in the verse of the seventeenth century—agreeably so in some of the smaller poems of Suckling, and Carew, and Sedley; overpoweringly so in the extravagant satire of Butler; and disgustingly so in the classic travesties of Cotton and Phillips. It mingled with its other elements in the verse of Pope, and Gay, and Swift; in the prose of Addison, and Steele, and Fielding, and Smollett; and, later, in that of Sterne and Goldsmith. It manifested itself at a still later period in the verse of Gifford, and Canning, and Wolcott; in the political epistles of Moore; in the savage literary satire of Byron; and in that riotous exhibition of the best and the worst of human nature—"Don Juan"—which is at once the glory and the shame of his genius. Byron created a new epoch in the history of English humorous poetry—an epoch which is of greater intellectual significance than any since that of Shakspeare, and which has since been sustained and enriched by Hood, and Præd, and Thackeray, and Locker,—four delightful masters of metrical pleasantry who are worthy of the race to which they belong. This epoch has now to acknowledge a new master in Mr. Austin Dobson.

We know nothing of Mr. Dobson, except what we learn from Mr. Stedman's preface, which informs us that he was born in 1840, and that he has been a government clerk in London for twenty-two years. He is the author of two volumes of verse, "Vignettes" (1873), and "Proverbs in Porcelain" (1877), which we read at the time of publication, and in which we found more enjoyment than in the poetic work of any of the younger English singers with which we compared them. We have read them since, or the substance of them, in the handsome volume before us, and our first impressions are more than confirmed. Mr. Dobson is a man of genius, with many and beautiful gifts. He knows what he can do, as well as what he cannot do, and never disappoints us by attempting what is beyond his powers. His inclination is toward the comedy of poetry, but he is not averse to its tragedy, in handling which he is exceedingly skillful. We hardly know whether to smile or to sigh while we read him, he is so thoroughly possessed by the humorous and the pathetic element, and we compromise by doing both. He lacks nothing that he ought to have to enable him to accomplish the work that he undertakes. He has discovered the secrets of the masters, to which he has added secrets of his own, of equal, if not of greater value. His ideal of humorous poetry is similar to if not identical with that we receive from the high comedy of Shakspeare, and his execution is as perfect as his conception.

This is high praise, no doubt, but it is not thoughtlessly bestowed, for we have read Mr. Dobson with an eye to discovering blemishes, and have failed to

* Vignettes in Rhyme, and Other Verses. By Austin Dobson, with an Introduction by E. C. Stedman. New York: Henry Holt & Co.

find them. There is not a careless line in his book—not a phrase that has not been well considered—not a rhythm that has not sung itself into melody. His technique is faultless. His English is manly and direct, and while it is not copious, it is singularly simple and fresh. He has a rich imagination, a subtle sense of the picturesque, and a pleasant vein of reflection. If he does not startle us with the originality of his thoughts, he satisfies us with their aptness, their sincerity, and their purity.

We have not space to analyze Mr. Dobson further, however great our inclination; nor is there any reason why we should, for the world of American readers is by this time familiar, no doubt, with, and in full enjoyment of, the work of this exquisite young English humorist. We content ourselves, therefore, by giving two examples of his powers,—one the pathetic close of a little life, the other a bantering address to critics.

“THE CHILD MUSICIAN.

“He had played for his lordship’s levee,
He had played for her ladyship’s whim,
Till the poor little head was heavy,
And the poor little brain would swim.

“And the face grew peaked and eerie,
And the large eyes strange and bright,
And they said—too late—‘He is weary!
He shall rest for, at least, to-night!’

“But at dawn, when the birds were waking,
As they watched in the silent room,
With the sound of a strained cord breaking,
A something snapped in the gloom.

“’Twas a string of his violoncello,
And they heard him stir in his bed:—
‘Make room for a tired little fellow,
Kind God!’—was the last that he said.”

“MORE POETS YET.

(*Rondeau.*)

“More Poets yet!—I hear him say,
Arming his heavy hand to slay;—
‘Despite my skill and ‘swashing blow,’
They seem to sprout where’er I go;—
I killed a host but yesterday!’

“Slash on, O Hercules! You may.
Your task’s, at best, a Hydra-fray:
And though you cut, not less will grow
More Poets yet!

“Too arrogant! For who shall stay
The first blind motions of the May?
Who shall out-blot the morning glow?—
Or stem the full heart’s overflow?
Who? There will rise, till Time decay,
More Poets yet!”

Only a poet could, and only a generous poet would, have written Mr. Stedman’s introduction. It is an admirable specimen of criticism, a remarkable record of friendship, and a perfect little masterpiece of prose.

Doctor Wines and his Last Work.*

TACITUS pronounced his father-in-law Agricola happy, not only in the renown of his life, but in the timeliness of his death—a phrase that has passed into a proverb, like so many of that terse

analyst’s epigrams. In a very different sense, but with equal truth, this saying can be applied to Doctor Wines, the illustrious prison-reformer, whose book describing the prisons and reformatories of the world lies upon our table, fresh from the press, while the author has for three months lain buried in Philadelphia, not far from those earlier prison-reformers who took up the work of Howard where he laid it down, and made the name of Pennsylvania known for its excellent prison as widely as Penn or Franklin had given it fame for other cause, in the seventeenth and the eighteenth centuries. Doctor Wines himself was the modern successor of Howard, performing upon a wider field and with the appliances of modern analysis and state administration the same task of investigation and enlightenment in respect to prisons which the Buckinghamshire sheriff took upon himself a hundred years ago. The volume before us shows how well Doctor Wines fulfilled his mission, which, as Burke said of Howard’s, was “not to survey the sumptuousness of palaces or the statelyness of temples, but to dive into the depth of dungeons; to survey the mansions of sorrow and pain; to take the gauge and dimensions of misery, depression, and contempt; to remember the forgotten, to attend to the neglected, and to compare and collate the distresses of all men.” It was more than this, for Doctor Wines undertook systematically and by a large induction from the experiments of a hundred years to frame a working-plan for the prevention and repression of crime and for the restoration of the criminal to society.

The extent to which he has succeeded in this undertaking will appear from a perusal of the book itself. We do not hesitate to say that it is at once the most exact manual and the most complete history and exegesis of prison discipline that has appeared in our language; and it is worthy to be compared, for learning and philosophy, with the work of Beccaria, Mittermaier, Lieber, and Charles Lucas. The latter, who is not dead, as some of the cyclopedias report, but still reads papers before the French Institute, has recently paid his homage to his American co-laborer. M. Lucas is seventy-seven—a few years older than Doctor Wines—and began his studies on prison discipline thirty years before Doctor Wines took up the subject. But so energetically did our countryman, from 1862 to the end of 1879, devote himself to the work, that he soon overtook M. Lucas and became an authority in all parts of the civilized world on the questions which he discussed. To Doctor Wines alone we owe the calling of the first National Prison Congress in the United States, held at Cincinnati in October, 1870, and presided over by President Hayes, then Governor of Ohio. Doctor Wines also originated and organized the International Prison Congress at London in 1872, having been commissioned by President Grant to represent the United States in that assembly, and in the subsequent International Congress, held in 1878 at Stockholm. From the large mass of information collected and brought together at these world’s congresses and from the correspondence which he carried on before, between, and after

*The State of Prisons and of Child-Saving Institutions in the Civilized World. By E. C. Wines, D.D., LL. D., Honorary President of the International Congress of Stockholm. Cambridge: John Wilson & Son. 1880.

them, Doctor Wines obtained for his great work, now published, the most comprehensive view of prisons, reformatories, and penal systems throughout the world which has ever been presented in print. His statistics are recent, his digest of laws and systems is thorough, and his style is so fresh and vivid that the volume charms by its manner, while it burdens the reader with its weight of matter.

Occasionally this vivacity of style draws Dr. Wines into a familiar or colloquial expression a little at variance with the seriousness of his subject. Now and then, too, his enthusiasm, always a charming trait in a septuagenarian, leads him into commendation of well-meant efforts in countries like Japan, where all that can yet be praised by the practical reformer is the aim in view. We doubt if torture is so far discontinued in Japan as Doctor Wines's text might suggest; we question a little, too, the actual benefits conferred upon Russia by the few prison reformers who have labored in that half-civilized empire. But these are slight matters, and the error—if it be one—is a generous error, such as men like Doctor Wines fall into, and which is better than the exactness of colder natures. In his statements and commentaries on the prison systems of Europe and America, his judgment is as remarkable as the extent of his knowledge. If other men could have acquired so much information, they could not have held it so firmly, wielded it so lightly, nor reasoned from it so justly. He had learned the great art of the philosopher—how to generalize safely—and to this he added an American practicality which Doctor Franklin and so many less distinguished countrymen of ours have possessed.

A few of Dr. Wines's friends—Mr. Horatio Seymour, Senator Blaine, Doctor Henry Barnard, Professor Wayland, Mr. Andrews, of Ohio, and others—have undertaken to secure the purchase by subscription of the first edition of this book, of which only 1,000 copies are now issued. It may be ordered of the publisher, however, and it is possible that hereafter a popular edition may be printed for the use of prison officials and those thousands of men and women who now interest themselves in the subjects of which the book so usefully treats. But for the present the number of copies is small, and will soon be exhausted. It contains more than 700 octavo pages, uniform in type and paper with Adams's "Life of Gallatin," and has been supplied by Doctor Barnard with a good index.

Gardner's "Common Sense in Church-Building."*

MR. E. C. GARDNER, whose works on domestic architecture and interiors are well known, has printed a modest little volume on church-building. The writer expressly disclaims any attempt to give a learned discourse upon the architecture of

churches; but, in a familiar and conversational style, he has presented his protest against what appear to him to be false and inconsistent methods of building. Many of the questions which are discussed in town and country parishes, with much heat and earnestness, when a church building project is before the people, are here raised by correspondents, who have all sorts of opinions. The author answers their letters, and thus gives, incidentally, the precise information which is sought for in numerous instances. There is no point of difference, however slight, no whim, however unreasonable, which is too insignificant for patient discussion, provided it has ever been brought up in the debates of a community intent on building a church edifice. The ventilation, lighting and warming, the relative position of congregation and pastor in the building, and the minor details of the arrangements, within and without, are all touched upon by the painstaking writer. And, although the reader may not always agree with the conclusions reached, if he is interested in any church-building project, he will find this unpretending little volume of great value to all concerned.

Du Maurier's "English Society at Home."*

THE recent death of "Cham" has called attention to the foremost caricaturist of Paris, a man of some pretensions to a noble name, who, during the last thirty years, has amused Paris, and consequently made a fortune for himself. The methods of Cham were entirely unlike those of Du Maurier,—as unlike, in fact, as Parisian journalism is unlike London journalism. Du Maurier inherits, with the position of draughtsman laureate for "Punch," the traditions of John Leech, Richard Doyle, and Thackeray. The journal for which they worked was carried on with much stricter reference to its name than might at first appear. Less than in Paris does the out-door peripatetic Punch-and-Judy show of London appeal to grown people; or, perhaps it would be better to say, grown people in England are seldom amused by Punch-and-Judy than are adults in Paris by its counterpart, "Guignol." London "Punch" has kept its audience by a species of wit that would be quite in place in the nursery, and yet has strength and sharpness enough to hold its own in the drawing-room. It need not be said that the jokes of Cham in "Charivari" are neither suited to children nor always in the best taste for the reading of young ladies. Du Maurier, on the other hand, is more pre-eminently an amuser of well-bred young gentlemen than were ever any of his predecessors. The audience for which "Punch" caters has never been so well addressed before; he comes nearer the actual tone of modern society, and is surer than any of his predecessors to hit on pleasantries which "society" will enjoy. Du Maurier is therefore an exponent of his surroundings to an unusual degree, and supplements this fortunate side of his talent by a skill in drawing, and especially in composition,

* Common Sense in Church-Building, illustrated by seven original plates. By E. C. Gardner, Author of "Homes, and How to Make Them," "Illustrated Homes," and "Home Interiors." New York: Bicknell & Comstock. 1880. Pp. 166.

* English Society at Home. From the collection of Mr. Punch. By George Du Maurier. London: Bradbury, Agnew & Co. New York: Scribner & Welford. 1880.

which makes him, from the artistic side, a very remarkable person indeed.

Nothing shows better the difference between Cham and Du Maurier, between the Paris and London comic press, than a comparison of the handiwork of the two men, irrespective of the thoughts conveyed by their sketches. Cham was of no great eminence as an artist, although, undeniably, there is a kind of genius in the rapidity and off-hand manner of his sketches. But what told in his work was the thought. Sharp, brilliant, often acid as a chemical, the idea drove home the blow so well, that one hardly cared whether the weapon was of gold or lathe. It was the genuine outcome of Parisian journalism, which has always been vindictive and brilliant, but never noticeable for the beauty of its vehicles. Paris journals are as a rule printed vilely on bad paper, and even the articles are apt to be more hurried than English and American work of the same kind. And so Cham made his sketches, in prodigious number, with great swiftness, and without regard, perhaps with contempt, for appearances. Place beside his wild sketches of grinning *bourgeois* the ornate, almost pseudo-classical cartoons of Du Maurier. They represent a public that respects itself intensely, and insists that it shall be respected, even if—let the paradox pass—it is being laughed at all the time. In this series of cartoons, look at No. 11, labeled "Noblesse oblige." The persons caricatured are a fat, noisy, vulgar duchess and a snob of the true English variety, who sneers at her when made to believe that the duchess is a cheesemonger's daughter, and admires her unblushingly when informed of his error. There is a great deal of careful work in the scene. The snobbishness of the snob sitting over by the wall of a drawing-room is delicately indicated by his somewhat free-and-easy pose; the vulgar duchess shows her vulgarity merely by her broad smile, heavy figure, and one arm akimbo. The idea is ancient and threadbare, and is touched gently. It is a pretty picture, with a dash of humor in a few of the figures—that is all. Cham would never have elaborated in this manner, and would have given a terse piece of wit in print, which would have stung somebody, whether it happened to be in good taste or not. In fact, one may say that Du Maurier is thoroughly imbued with respect for what is meant by the slang term "in good form," imported from the universities into English society. He is always in the most superlatively "good form."

Beside the sobriety and gentility of his ideas, Du Maurier has a style of drawing ladies and gentlemen that is flattering, both to society people and to the English. Formerly, his theory of an aristocratic figure was carried to great length; he made the heads of his characters so small that it verged on the ludicrous. He seems to have corrected himself of this fault, and succeeds in combining grace and a thoroughly modern look in a way that no other draughtsman approaches. Moreover, his figures stand well when they are at rest, sit well when sitting, and, above all, move well when walking. If his English nobles are somewhat stereotyped, his

French musicians are full of humor and truth. And, as before said, he is unapproachable in composition. Whether it is a few figures on a lawn, as in No. 15, "A Rising Genius," or a crowd of grown-up dancers surrounded by the children they ought to be amusing, as in No. 43, "Self-Sacrifice," nothing could be brighter than the arrangement of the actors in the scene. No. 15 has the following legend:

YOUNG LADY (*in the course of conversation*). "You have read 'Pendennis,' of course?"

FASHIONABLE SCRIBBLER (*who is, however, quite unknown to fame*). "A—'Pendennis!' Ah!—let me see! That's Thackeray's, isn't it? No, I've not. The fact is, I never read books—I write them!"

The best cartoons, so far as people are concerned who do not live in London, are those relating to the affectations of musical and literary snobs, which are the same the world over. Only, if travelers are to be believed, their absurdity reaches a climax in a sketch from what Du Maurier calls "Passionate Brompton." Room must be found for this (No. 49), certainly the wittiest of all the good things in the volume. The scene is a room full of bric-à-brac, with a cadaverous lady arrayed in a high-art gown and seated on a high-art chair. It is called "Refinements of Modern Speech. Scene, a drawing-room in 'Passionate Brompton!'"

FAIR ÆSTHETIC (*suddenly and in deepest tones, to Smith, who has just been introduced to take her in to dinner.*) "Are you *Intense*?"

The Fourth Quarterly of "L'Art" (1879).*

THERE has been a sensible change in the management of "L'Art" during the last quarter of 1879. An effort is being made to issue more promptly and to publish the plates and wood-cuts in closer connection with the explanatory text. It does not follow that the effort should improve the character of the magazine as it comes to us, namely, in folio volumes of good size; but the regular subscribers to the weekly issues must find their comfort greatly increased. "L'Art" has taken the lead in its own department of periodicals with so much success that it should court rather than fear criticism. The last volume stands in need of something in the nature of a fillip to the pride of the editors. Not that the engravings and wood-cuts are in any sense inferior in workmanship to those which have gone before; on the contrary, there is equal, if not greater, skill exhibited in the mechanical beauty of the magazine; but the articles, taking them as a whole and weighing their collective merits against former volumes, are hardly up to the mark either in quantity or quality. Only a close and constant reader would notice the difference, which may be due to recent losses in the editorial staff. Besides Viollette-Duc, who is gone forever, "L'Art" loses the direct personal assistance of Charles Tardieu, in most cases a keen and appreciative critic, who has accepted a position on "L'Indépendance Belge,"

* L'Art. Revue Hebdomadaire Illustrée. A. Ballue, Paris. J. M. Bouton, New York: 1879. Cinquième Année. Tome IV.

and will hereafter continue to assist "L'Art" from a distance, and less energetically.

There is a well-merited eulogy of Viollet-le-Duc, by M. de Beaudot, and a bright and interesting sketch of the life of Jules Dupré, veteran landscapist, who survives almost all his old contemporaries of fame. One of his characteristic landscapes is etched with appropriate boldness by Chauvel. We also find here just what we want to know about Corot and his work in some other branch of painting besides that with which we are all familiar. On the wall of a bath-room in the house of an old friend in Mantes he painted a series of views, on a small scale as to size, but wide enough in their subject. They form an epitome of foreign lands, and are done with the lightness and individuality which might be expected from Corot. One panel is an ideal remembrance of the Gulf of Genoa, another of a gorge in the Tyrol. The lake of Nemi, Venice from the lagoon, and a glimpse of Neapolitan landscape, occupy spaces of different shapes but in no case of large extent. In his own garden at Ville d'Avray, the old painter executed various landscapes on the walls of a summer-house which stands among bushes and trees; they recall some of the ideal landscapes of the owner. One small oval is a scene from the heights of Sèvres, looking down on Paris, others are from the garden itself or the neighborhood of Ville d'Avray. The church of the same place was decorated by Corot without compensation, to this extent: Corot made the designs and sent a pupil to carry them out. They are not of large size, and are high up on the walls. From the sketches given by Robaut it is evident that the landscapes are better than the figures, although these have a certain dignity, and often fine lines. We learn that the color in all is either "infinitely gentle" or attractive through its unusualness.

Much space is given to a collection of precious articles and furniture at Genoa called the collection Mylius, and to the treasures of the palace of San Donato at Florence. Moreover, the artistic value of what may be termed superior cabinet-work is examined at length and with a profusion of examples by Edmond Bonnaffé. English affairs continue to occupy a good deal of attention. The drama in England is highly complimented for progress made, and Philippe Burty writes a most appreciative biography of the late etcher Edwin Edwards, giving striking examples of his talent for landscape etching. The same clever writer on art continues his talks about the French masters of the last century, who, after falling into disgrace, were recently drawn from obscurity by various indefatigable collectors (such as the Goncourts), who joined to a love of art a strong talent for literature. Aimé Giron describes an interesting series of frescoes rescued from ruin by Prosper Mérimée. They are in the Cathedral of Puy-en-Velay, and are quaint and in some respects admirable works of art. M. Giron attributes them to Benedetto Ghirlandajo, a brother of the great Ghirlandajo, who is known to have worked at his profession more above than below the Alps.



THE CHILD'S CATECHISM OF COMMON THINGS



MR. BLUM'S clever design upon the cover of this little book reflects credit upon the discernment of the publishers, Messrs. Henry Holt & Co., in thus employing the services of this young artist, who is no longer to be described as "promising," but who has an enviable career before him. They have, moreover, paid a compliment to the good taste of the public, which, we venture to say, has had quite enough of the gingerbread, ecclesiastical and rustic styles of book decoration and is ready for something more in keeping with current progress in art. A few examples of good book-design we have already had in this country; but we are in this respect far behind our English cousins, who, whether from their own good taste or from respect for local artistic vogue (it matters little), have availed themselves of the services of their best draughtsmen. That our backwardness is not for lack of material to draw upon, may be inferred from the decorative work which our artists are doing in other departments, and from the few notable pieces of book-design already produced here, among which this of Mr. Blum's ranks well as a striking suggestion of the personality of a book. He has drawn with sly humor the boy who "wants to know," and who yet stands in awe of the multitude of things to be known—"vegetable, animal and mineral."

The reader who is attracted by this animated query will find inside the covers a set of answers to very leading questions, into which Mr. Champlin, who prepared the admirable "Young Folks' Cyclopædia of Common Things," and is now at work upon a like "Cyclopædia of Persons and Places," has packed an extraordinary amount of information as to the every-day facts respecting the three natural kingdoms. It is meant for school use, like the "Scholar's Companion" of the present generation's childhood; but it belongs, also, on the child's bookshelf of the home library, and a copious index makes it a useful book of reference, even for grown folks.

THE WORLD'S WORK.

Progress in Electric Lighting.

THE use of the voltaic arc for illumination has made a steady advance in popular favor within the last year. Lamps of from a few hundred candle-power up to many thousand candle-power are being set up as permanent fixtures in shops, halls, stores, and in streets and squares. The rivalry of the different manufacturers has led to great improvements in the power and convenience of the machines for maintaining the electrical currents, and in the lamps. The machines are all constructed on the same general principles, and the lamps have gained both in steadiness and in simplicity, and even in elegance of form, some of them being quite ornamental. The prices of the machines and lamps have been materially reduced, and this fact, with the greater efficiency of the lamp, has drawn attention to the value of this method of electrical lighting and placed the matter upon a firm business basis. The light of the voltaic arc may now be recognized as a permanent feature of modern civilization.

In lighting streets this form of electric lamp has not displaced gas, nor is it likely to do so at present, for the simple reason that people are content with a very little light. To light a mile of any given street would cost more by the voltaic arc than by gas. On the other hand, the electric lamps would give from six to eight times as much light, and it appears the public, or at least, city corporations, are not willing to pay one-third more for eight times as much light. It would therefore appear that the advance in use of the light springs from special and private wants. For lighting streets in front of hotels, theaters, churches and stores, where an intense light is wanted for part of the night at a particular place, the voltaic light is both efficient and cheap. In all cases where steam-power is available, as in hotels and stores using elevators, an electric lamp from one to ten thousand candle-power may easily be provided. A single machine and lamp giving an arc light of one thousand candle-power can now be procured for \$150. Lights of from 3,000 to 10,000 candle-power—and those are sufficient to flood any ordinary street with light for a distance of one block—cost for machine and lamp from \$350 to \$400. The smaller lamp would use about seven-tenths of a horse-power and the larger from three to three and one-half horse-power. The cost of maintenance will be about one cent and a half per hour for the carbons, in addition to the motive power and attendance. This last item will be very small for the machine and lamp. It may here be observed that for places where steam is already provided, a small, two-horse-power engine for running a machine costs about \$150. To these costs must also be added the copper wire for connections. These cost, at present prices, about ten cents a meter (three cents per foot).

Some of the manufacturers of these lights employ

as many as sixteen lamps of 2,000 candle-power each, for one machine, but the general disposition seems to be to give one light to one machine. As this light is now made on a large scale and at these very low prices, it may be observed that owners of steam-engines that are idle at night are already making arrangements to employ their power in running electric lights, which they let by the hour to those of their neighbors who wish to light up their shops or factories, or the streets in front of their premises. For docks and all out-of-door night-work the electric light has already become indispensable wherever motive power of any kind can be obtained.

Concerning some of the later improvements made in this method of electric lighting, two new features may be observed. In the machines the induced current in the magnets, in opposition to the current generated by the movement of the armatures, is now shunted or short-circuited during the time it is in opposition to the current in the armatures. This is claimed as a great gain in the amount of current utilized, and from observation, appears to give a decided gain in light for a given machine.

In the lamps, one of the latest improvements is in the manner of regulating the movement of the carbons. The lower carbon is fixed, the upper carbon is fastened to the base of a rod having a ratchet on one side. This rod is free to rise and fall, and in its movement downward, by its own weight, sets in motion a train of wheels. The rod and wheels are supported on a lever having a slight vertical play, and controlled by an electro-magnet. The train of wheels is controlled by a detent that is controlled by a second and much smaller electro-magnet. In operation, the current divides between the two magnets, the smaller releasing the detent and allowing the carbon to descend till it touches the lower carbon, and the circuit is made through them both. This accomplished, the larger magnet comes into play, lifting the carbon by raising the lever slightly with the train of wheels, and pulling the carbons apart just the right distance. As the carbon is burned away the current weakens, and is directed through the smaller magnet, and the detent is released and the carbon descends again. This reduces the lamp to the utmost simplicity, and gives it a precision of action that secures great steadiness, in the light, or sufficient steadiness to make the lamp available for all practical purposes in the lighting of large spaces, both without and within.

Dynamo-Electric Machines in Telegraphy.

THE most important advance in telegraphic science lately announced is the successful application of dynamo-electric machines to the work of the battery, in supplying the electric current needed in the line wires. The machines used are of the "Siemens" pattern, and they are arranged in groups of five machines, one being employed to excite the field

magnets of the remaining four. The machines are joined in a group by connecting the commutator-brush of one machine with the next, and that with the next, and so on. A current from the first machine has a low tension, the next a higher tension, and so on. In practice, the first machine is found to give 50 volts, the second 100, the third 150, and the fourth 250 volts. Only one group of five machines is in operation at date of writing, and no elaborate experiments have yet been made with them, but sufficient has been learned to warrant the largest telegraph office in the city in replacing its 14,000 battery-cups with ten machines, and it is confidently expected the wires will be worked with equal power at a very material saving of space and cost of plant and maintenance. The machines have each sufficient power to run an electric lamp of 1,200 candle-power, and are driven at a speed of 920 revolutions a minute. It is thought that machines arranged in groups in this manner will soon supersede batteries in all large telegraph offices.

Improved Refrigerating Process.

IN reducing the temperature of refrigerator-cars and chill-rooms by the expansion of compressed air, great difficulty has been met in cooling the condensed air, and in preventing the formation of ice and snow in the apparatus. To obviate this, several improvements in such cooling-machines have recently been brought out. The air compressed by steam-power is always heated by the compression, and to cool it as far as possible before it is allowed to expand, it passes from the compressors to a pair of upright iron cylinders, entering the first near the bottom and passing into the second by a pipe that joins the two cylinders near the top. At the top of the first cylinder is an inlet pipe for water, ending within the cylinder in a rose to distribute it in a fine shower. The water is forced into the cylinder against the pressure of the air by a force-pump, and falls in spray through the air upon a series of metallic diaphragms pierced with fine holes, and drips through these to the bottom of the cylinder. The object of this spray and drip is to secure as intimate a mixture of the water and air as possible, so that the air may be deprived of its heat. The water used is as cold as can be procured conveniently, and when the cylinder fills with water it may be removed through an outlet below. The air passes through this cylinder to the second, and there meets a great number of diaphragms pierced with fine holes. Here the process is the reverse of that in the first cylinder, the diaphragms tending to check and take up the moisture of the air. The air then passes out at the bottom of the cylinder through a series of pipes that pass through the chill-room, or through one of a train of refrigerator-cars. The design of this is to lower the temperature as far as possible, and to condense the moisture and permit it to run back into the cylinders before it can freeze. The compressed air, thus cooled and dried, passes to the chill-room, where it is to be expanded to reduce its temperature. It is reported that by these improvements in this process of refrigeration a lower tem-

perature is obtained with almost entire freedom from the formation of snow and ice in the chill-room.

Experiments with Blast.

IN the use of the hot or cold blast in metallurgical operations, as in the blast-furnace and Bessemer converter, it is proposed to pass the air to be used in the blast over some desiccating material, such as sulphuric acid or chloride of calcium, for the purpose of extracting the vapor of water. The object is to remove the water before it enters the furnace, both to prevent the formation of hydrogen from the decomposition of the water and to save the heat that would be lost in this decomposition. The blast delivered in a dry state thus saves fuel and prevents the injurious action of the hydrogen on the metals under treatment. The plan is now being made the subject of careful experiment on a large scale in a blast-furnace.

A New Form of Air-Injector.

IN warming and ventilating by a current of heated air driven into a building, a blower, or exhaust-fan, is commonly employed. A new device for securing the same results uses a new form of air-injector operated by compressed air. At one point in the air-duct used for taking the air from outside the building a pipe from the air-compressor is fitted with a nozzle having an annular opening and placed just within a funnel-shaped pipe or a contraction of the main air-box, thus forming an injector. At the top of the building a second injector is placed in the air-shaft leading from the ventilators. A pair of such injectors are said to be quite equal to the requirements of a large school-house or public building, and by varying the pressure of the air the volume of air sent through the ventilators may be varied within wide limits. The invention has the merit of simplicity, convenience and cheapness, though quite as much motive power is probably required to drive the compressor as to move an ordinary exhaust-fan.

A New Globe for Schools.

AMONG new school apparatus is a globe designed to show both actual and relative time. The globe itself is covered with a finely executed map giving all the data of mean temperature, ocean currents, etc., in addition to the usual geographical information put on school maps. It is mounted on its polar axis in a meridian ring, the upper part of the ring supporting a clock dial of transparent glass. The hands of the clock are placed on the under side of the dial, and may be readily seen through it, while the clock-work, designed to run four days, is placed inside the globe. The clock-work also gives the globe a daily motion on its axis. At the equator is a ring marked with the hours for a day, and from this the relative time of any part of the globe may be easily estimated. The meridian ring is adjusted for a certain amount of play in changing the position of the polar axis, and may be secured in any position by a set-screw. The apparatus will, no doubt, prove of value.

BRIC-À-BRAC.

The Princes' Noses.

A MODERN IDYL.

TO HER, my gracious Mistress, who hath deign'd
Of old to accept Her Laureate's every lay,
And to the memory of that Good Prince,
A verdure clinging ivy-like round all hearts,
Whose virtues still survive in our essays,—
These idle words I dedicate, naught worth
Save as the homage of a duteous muse!

I stood with first-mate Smith upon the bridge,
And question'd him: "The rumor, was it true,—
That our two Princes, hopes of England's Crown,
Grand-children too of Him the Well-beloved,
Had in some sportive frenzy, likely in youth,
Tattoo'd each others' noses?" Smith replied,
Laying one fore-finger beside his own
And winking as a cat doth at the fire,
That twitter of his eyelid holding me:
"It is not quite," he said, "as you have heard.
They were two merry dogs, those royal boys!"
And here he raised his arm and smiled in his
sleeve.

"And as we cross'd the Line—Of course you
know

We sailors have a custom" — "I have heard,"
I said; "but tell me what the Princes did."
"That I was steering to," the mate rejoin'd.
"My bowlines, 'twas a rummy spree! those lads—
Two merry boys, you well may say, they were."
"But tell me," for I could but interrupt,
Anxious to learn the truth of that report,—
"Did they tattoo" — "Ay, love your eyes! they
did:

And this was how." And so he spun his yarn:
I listening with impatient eagerness.

"It was a blazing morning: glad enough
Were some of us to get outside our duds
And try warm water over the ship's side.
Those boys (my eyes, but they were merry dogs!)
As I have said, stood all outside their duds,
Drying themselves: it was not difficult
With the glass at a hundred and nineteen. 'Twas
then

One ask'd about the Line and where it was
And what to be done: and somehow thus it hap'd,
One telling of this experiment, one of that,
The tattoo into consideration came.
They jump'd at it, both of them,—I mean, jump'd
When it was spoken of. You may be sure
We took them at their word, right loyally,
And then they jumped again. Such merry boys!
We almost died of laughter, seeing it done
And the blue anchors on the delicate skin
Like early violets upon banks of snow."

So Smith, with smile a trifle strain'd,
In sailor fashion sentimentalizing,
Likening a princely nose to snows upheap'd.
But I: "Good heaven," I cried, "'twas actually
done!"

And stood aghast with horror at the thought,
Not so much of the deed as the consequence.
"Good heaven," I cried, "Their Highnesses will
squint!"

While Smith irreverent laugh'd a senseless laugh.
And thereupon I thought of coming years,
When our revered Queen and her royal Son
Are gather'd to their glorious ancestors:
How One shall sit on England's island throne
Mark'd with an anchor on the Imperial Nose,

"Looking two ways for Sunday." It may be
The fashion, then, and rigorous as dress-coats,
To tattoo noses. So my thought stept back
To our more simple-manner'd ceremonies.
How will the Royal Grandmother receive
Her anchor'd "Vikings? Thus I further mused.

Suppose a levée day; the lads come home.
I see them from the top of a Portsmouth coach
(Four-horsed—three piebalds and a roan) alight
At the White-Horse Cellar, Piccadilly, and,
Swift-hurrying to embrace their Grandam fond,
In their salt-season'd costume drive to Court,
Chaff'd by the Hansom cabby as they drive.
Herself in her full stateliness I see—
The Empress on her throne, scepter'd and crown'd,
Her nobles girdling her, a glistening mass
Of diamond sheen, outshining Indian suns;
And eyes, than diamonds brighter, of fair dames,
Veil their haught splendors in the imperial blaze,
Like stars lost in the sunrise. I can see
All those white bosoms rise and fall; but sound
Breaks not the reverent quiet, save a hum
Of loyal admiration as the crowd
Gives way and the Sailor Princes, hand in hand,
Advance and bend the knee and bow their heads:
And then the uplifted anchors meet their gaze
Of Majesty. An overpowering pause!
Till my thought, bursting the silence, thus had
vent—

What will the Queen say?
But Smith only laugh'd.

And, as I look'd at him, remonstrative,—
"Their gracious grandmother will never see
The heaving of those anchors." And thereat
Join'd his two thumbs together, laughing low;
And chuckled as restraining him a while,
Then thunder'd his guffaw. But what the jest
I could not guess. Yet evermore he laugh'd,
As ruminating on some goodly joke.

Still I do think he told the truth to me.

W. J. LINTON, AFTER ———.

1914

An International Episode.

"Yes, I liked you at first, I must confess,
And a week ago I might have been won,
But that is all over," she pensively sighed,
"For I find you are only a younger son."

There was silence awhile on that Alpine height,
They could hear the sound of a mountain stream;
He twirled his mustache and his alpenstock,
While she softly warbled "It was a Dream."

"We leave to-morrow for France," she resumed,
"I hope I shall meet you at Paris next spring;
Now don't say I've flirted, for culture, you know,
Is hardly consistent with that sort of thing."

"If it's not a flirtation, what, under heaven,
Would your ladyship call it?" he fiercely said,
And the question, I own, is one that well
Might bother the average British head.

She turned her face to the rosy west
Where the flush of dying day still glowed;
"Tis nothing," she pouted, reflectively,
"But an 'international episode.'"

ELIZA C. HALL.



**PLEASE DO NOT REMOVE
CARDS OR SLIPS FROM THIS POCKET**

UNIVERSITY OF TORONTO LIBRARY
