

LIBRARY

UNIVERSITY OF CALIFORNIA
SAN DIEGO



presented to the
LIBRARY
UNIVERSITY OF CALIFORNIA • SAN DIEGO
by
FRIENDS OF THE LIBRARY

Dr. Denis Fox
donor



*Denis L. Fox
2450 Aduth Road
La Jolla, Calif. 92037*

CHAMBERS'S
ENCYCLOPÆDIA

A DICTIONARY

OF

UNIVERSAL KNOWLEDGE

NEW EDITION

VOL. VI

HUMBER TO MALTA



WILLIAM & ROBERT CHAMBERS, LIMITED

LONDON AND EDINBURGH

J. B. LIPPINCOTT COMPANY, PHILADELPHIA

1901

All Rights reserved

The following Articles in this Volume are Copyrighted by J. B. LIPPINCOTT COMPANY in the United States of America :

IDAHO.

ILLINOIS.

INDIAN TERRITORY.

INDIANA.

IOWA.

IRVING, WASHINGTON.

JACKSON, ANDREW.

JEFFERSON, THOMAS.

JOHNSON, ANDREW.

KANSAS.

KENTUCKY.

LEE, ROBERT EDWARD.

LINCOLN, ABRAHAM.

LONGFELLOW, HENRY WADSWORTH.

LOUISIANA.

LOWELL, JAMES RUSSELL.

MAINE.

Among the more important articles in this Volume are the following:

HUME, DAVID.....	J. HILL BURTON.	KEAN; KEMBLE.....	ROBERT W. LOWE
HUNGARY.....	BARBOLOMIEW GUNSZT.	KEATS.....	F. T. PALGRAVE.
HUNT, LEIGH.....	F. HINDS GROOME.	KEBLE.....	REV. PROF. W. LOCK.
HUSBAND AND WIFE.....	THOMAS RALEIGH.	KENT; LINCOLN.....	J. C. GROOMIE.
HYDRODYNAMICS.....	Professor CARROLL G. KNOTT.	KENTUCKY.....	Professor FRANK B. GREENE.
HYDROGEN.....	Dr L. DOBBIN.	KEPLER.....	ROY. E. B. KIRK.
HYDROPHOBIA.....	M. PASTEUR & Prof. J. A. THOMSON.	KHIVA; KANDAHAR.....	Professor ARMINIUS VAMBÉRY
HYGIENE.....	Dr ANDREW WILSON.	KINGSLEY.....	ULRICH BURKE.
HYMN.....	REV. JOHN JULIAN.	KNOX.....	P. HUMF MILNE, LL.D.
HYPNOTISM.....	Dr R. W. FELKIN.	KORAN.....	REV. JOHN MILNE.
IBSEN; LESSING.....	J. T. BEALEY.	KUFIC COINS.....	STANLEY LANE-POOLE.
ICELAND.....	JÓN A. HJALTALF.	LACE; LEATHER.....	JAMES PATON.
IDAH0; INDIAN TER.....	JACQUES W. REDWAY.	LAFONTAINE.....	WALTER HWYTE.
IGNEOUS ROCKS, &c.....	Professor JAMES GEIKIE.	LAKE-DWELLINGS.....	JOSEPH ANDERSON, LL.D.
ILLEGITIMACY.....	BENJAMIN TAYLOR.	LAMB, CHARLES.....	CHRIS ANSER.
ILLINOIS.....	ColoRD H. G. REEVES.	LAMPS.....	WILLIAM LOVEL.
ILLUMINATION; INDEX.....	HENRY B. WHITLEY.	LANCASHIRE.....	C. FAIRBAIRN.
ILLUSTRATION.....	J. R. PAIRMAN.	LAND LAWS.....	J. BOYD-KINSLAR.
IMMIGRATION.....	ARNOLD WHITE.	LAÓ-TSZE.....	Professor LEBGE.
INDEPENDENTS.....	REV. W. COOKE RUSSELL.	LASSALLE.....	THOMAS KIRKUP.
INDIA.....	SIR R. HARDY TEMPLE, G.C.S.I., D.C.L.	LATIN; LUCRETIVS.....	REV. W. J. PROMBIER
INDIANA.....	GEORGE J. LANGDALE.	LEAF.....	Professor PATRICK GEEDER.
INDIAN OCEAN.....	SIR JOHN MURRAY.	LEE, GENERAL.....	N. B. WEBSTER.
INDIA-RUBBER.....	JOHN A. CLAUDE.	LEDS.....	J. FENWICK.
INK.....	ROBERT IRVINE.	LEIGHTON; LETTERS.....	THOMAS DAVIDSON.
INSANITY.....	Dr F. S. CLOUSTON.	LEIPZIG.....	FINDLAY McHEAD.
INSCRIPTIONS.....	CHAS. ISAAC TAYLOR.	LEONARDO DA VINCI.....	J. M. GRAY.
INSECTS & I. PLANTS.....	Professor J. A. THOMSON.	LE SAGE; LORENTE.....	JOHN ORMSBY.
INSURANCE.....	GEORGE KING, F.S.A.	LEYDEN, JOHN.....	ROBERT COCHRANE.
INTERNATIONAL LAW.....	JAMES M. IRVINE.	LIBEL.....	FRANCIS WATT.
IOWA.....	F. W. HORSFIELD.	LIBRARY.....	T. G. LAW, LL. D.
IRELAND.....	JUSTIN MCCARTHY, M.P.; Prof. MAC- KINNON; Prof. G. T. STOKES, D.D.	LIFEROAT.....	C. DIBBIN (See Lifeboat Inst.).
IRON.....	W. MATHER WILLIAMS.	LIGHT; LENSES.....	Dr ALFRED DANIELL.
IRVING, WASHINGTON.....	F. H. UNDERWOOD, LL.D.	LIGHTHOUSE.....	D. & T. STEVENSON.
ISAIAH.....	Prof. GEORGE ALAN SMITH.	LIGHTNING.....	R. T. OMOND.
ISLAND; LATITUDE.....	HUGH ROBERT MILL, D.Sc.	LINCOLN, ABRAHAM.....	Professor J. P. LAMBERTON.
ISOCRATES; ISLEUS.....	F. B. JEVONS.	LION; LEOPARD.....	F. E. BEDDARD, F.R.S.
ITALY (Geog. & Hist.).	W. DEWDAS WALKER.	LIQUOR LAWS.....	SIR CHARLES WENTWORTH DOBIE.
(Literature).....	SIGNOR CANTAGALLI.	LINTE.....	COLIN SIALKER.
JACKSON, ANDREW.....	Professor J. P. LAMBERTON.	LITHOGRAPHY.....	J. R. PAIRMAN.
JAMES I.....	JOHN RUSSELL.	LIURGY; LITANY.....	MARQUIS OF BULL.
JAPAN.....	Professor DIXON (Tokyo).	LIVER.....	Professor HAYGARTH and Dr LUNDIE.
JAVA.....	E. METZGER.	LIVERPOOL.....	THOMAS EDISON.
JEFFERSON, THOMAS.....	Professor N. B. WEBSTER.	LIVINGSTONE.....	Professor W. G. BLAIRIE, D.D.
JERROLD, DOUGLAS.....	WALTER JERROLD.	LLOYDS.....	Col. HENRY MONTAGUE HOZIER.
JERUSALEM.....	SIR WALTER BESANT.	LOCKE.....	Professor A. CAMPBELL FRASER.
JEST-BOOKS; JESTERS.....	W. A. CLOUTON.	LOGIC; LOTZE.....	Professor FRINGLI-PATTON.
JESUS CHRIST.....	DEAD PAUPER.	LONDON.....	REV. W. J. LOTTIE.
JEW.....	EM. DEUTSCH and ISIDORE HARBEL.	LONDON UNIVERSITY.....	T. E. M. DOUSE.
JOAN OF ARC; JULIAN.....	THOMAS DAVIDSON.	LONGFELLOW; LOWELL.....	F. H. UNDERWOOD, LL.D.
JOB.....	REV. PROFESSOR A. B. DAVIDSON.	LOUISIANA.....	JOSEPH A. BRAXN.
JOHN'S GOSPEL.....	REV. J. SUTHERLAND BLACK.	LUTHER.....	Principal THOMSON.
JOHNSON, ANDREW.....	Hon. FREDERICK W. SEWARD.	LYLY, JOHN.....	A. B. BULLER.
JOHNSON, SAMUEL.....	Professor HALES.	LYLTON, BULWER.....	F. HINDS GROOMIE.
JENIS.....	W. FRASER RAE.	MACAULAY.....	WILLIAM WALLACE.
JURY; LAW.....	THOMAS RALEIGH.	MACHIAVELLI.....	SIGNOR CANTAGALLI.
JUSTICE OF PEACE.....	A. WOOD RINDON.	MACHINE GUN.....	Lieut. Col. H. D. B. DUNTON.
JUSTINIAN.....	Professor HENRY GURDY.	MADAGASCAR.....	REV. JAMES STRIBBLE.
JUTE; LEAD; LINEN.....	ALEXANDER GALLILLY.	MADRAS.....	Professor MICHEE SMITH.
JUVENAL; LUCAN.....	Dr J. P. STOLLER.	MAGNETISM.....	Dr ALFRED DANIELL.
KANSAS.....	NOBLE F. FRENCH.	TERRESTRIAL.....	Professor CARROLL G. KNOTT.
KANT.....	JAMES H. JOHNSON SHILLING, LL.D.	MAINE.....	Dr CHARLES W. GREENIE.
		MALAYS.....	Professor A. H. KEANE.

The Publishers beg to tender their thanks, for revising the article 'Thomas à Kempis,' to the Rev. S. KETTLEWELL; for 'Kindergarten,' to HERK K. FROEBEL; for 'Immaculate Conception,' 'Indulgence,' 'Infallibility,' 'Inquisition,' to His Eminence CARDINAL MANNING; for 'Iona,' to the DUKE of ABERNETHY; for 'Edward Irving,' to Mrs OLIPHANT; for 'Italy,' to Signor LUIGI BODIO, Director-general of Italian Statistics; for 'Jamaica,' to Chief-justice CHILD, St. Lucia; for 'Journ,' to the Very Rev. the GENERAL of the Order; for 'Leighton,' to the Rev. Dr Blair of Durham; as also to the Very Rev. the Deans of Lichfield and Lincoln, to Professor HUXLEY and to the town-clerks of Inverness, Leicester, Macclesfield, and other towns.

MAPS FOR VOL. VI.

	PAGE
INDIA.....	98
IRELAND.....	198
ITALY.....	240
ITALIA ANTIQUA.....	241

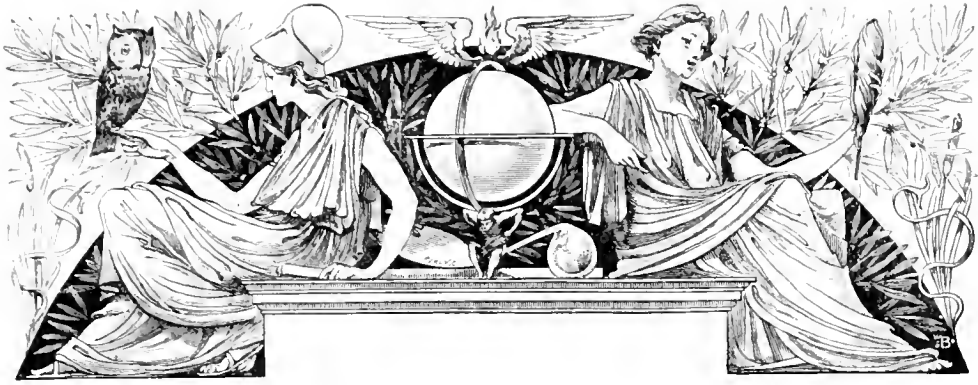

CHAMBERS'S ENCYCLOPÆDIA

A DICTIONARY OF UNIVERSAL KNOWLEDGE



H

Humber. the estuary of the rivers Ouse and Trent (and so of the Dove, Derwent, Wharfe, &c.), runs east and then south-east for a length of 38 miles, separating the counties of York and Lincoln, with a breadth varying from 1 to 7 miles. Its drainage basin, with an area of 9770 miles, is the largest in England; and by means of navigable streams and canals the Humber is connected across England with the Mersey, the Severn, and the Thames. The navigation is obstructed, especially on the north side, by banks and shoals. The Humber was the southern boundary of the ancient kingdom of Northumbria in the wider sense, and of Deira when Northumbria was divided into Bernicia and Deira; Mercia lay south of the estuary. By way of the Humber Danes and Northmen made many terrible incursions into England, notably in 867, 1013, 1066, and 1069. The great port on the Humber was anciently Ravenspur or Ravenspur, just inside Spurn Head. The process of erosion by the sea was already at work when Henry Bolingbroke landed here in 1399; soon after the place was wholly covered by the encroaching waters, and Hull became the port on the north shore, as Grimsby now is on the south. See *The Rivers of England* (Cassell, 1889), and *Boyle's Lost Towns of the Humber* (1889).

Humbert. See ITALY.

Humble-bee. See BEE.

Humboldt. a river of Nevada, rises in the NE. part of the state, and flows WSW. to Humboldt Sink, a lake over 40 miles in circumference, which has no outlet. Length, nearly 350 miles. The river, which is unnavigable even for canoes, is strongly impregnated with alkaline matter. The region through which it flows is barren, and the banks are destitute of trees or shrubs. The Central Pacific Railroad runs through the valley of the Humboldt.

Humboldt. FRIEDRICH HEINRICH ALEXANDER, BARON VON, one of the greatest of naturalists, was born at Berlin, 14th September 1769. His father, whom he lost when he was not quite ten years of age, was chamberlain to the king of Prussia. He studied at the universities of Frankfurt-on-the-Oder, Berlin, and Göttingen; and during his residence at Göttingen (1789-90) he made those visits of scientific exploration, the fruit of which was his first independent work, a treatise on the basalts of the Rhine. In the spring and summer of 1790 he made a tour through Belgium, Holland, England, and France. In June 1791 he entered the Mining Academy at Freiberg, where he enjoyed the instructions of Werner. His eight months' residence here led to the publication of his *Flora Subterranea Freibergensis* (1793). He was afterwards appointed to an office in the mining department, and spent some years in this capacity, chiefly at the Fichtelgebirge, in Upper Franconia. His researches here resulted in a work on the irritability of the muscular and nervous fibres of animals (1799). The desire of visiting tropical countries, however, led him to resign his office, and devote himself entirely to the study of nature. He spent three months at Jena, where he was the intimate associate of Goethe and Schiller. At Paris he contracted a friendship with Aimé Bonpland, afterwards his companion in many and various scenes. Some time after he obtained permission from the Spanish government to visit all the Spanish settlements in America and the Indian Ocean. He sailed from Corunna along with Bonpland on 5th June 1799. They visited Teneriffe, ascended the Peak, and made many scientific observations. On 16th July they arrived at Cumana in South America, and in the course of five years explored a vast extent of territory in what are now Venezuela, Colombia, Ecuador, and Peru, as well as in Mexico, which they crossed from west to east. In Havana Humboldt prepared materials afterwards employed in his *Essai Politique sur l'Isle de Cuba* (1826). At Paris he occupied himself in the

arrangement of his collections and manuscripts, and jointly with Gay-Lussac made experiments on the chemical constitution of the atmosphere. Having visited Italy, and returned to Berlin, he accompanied Prince Wilhelm of Prussia in 1807 on a political mission to France, and obtained leave from the government of his own country to remain there for the publication of his travels, for which the disturbed state of Germany at that time did not allow proper opportunity. He continued to reside in Paris till 1827. The wish of the king that he should reside in his native country was gratified in 1827, when he proceeded to Berlin, and there, in the winter of 1827-28, he gave lectures on the *Cosmos*, or physical universe.

In 1829 Humboldt again became a traveller, the Emperor Nicholas then sending out a well-appointed expedition to the north of Asia, to explore the Ural and Altai Mountains, Chinese Dzungaria, and the Caspian Sea. In this expedition Humboldt was accompanied by his two friends Ehrenberg and Rose. Its principal results were the scientific examination of the beds which produce gold and platinum, the discovery of diamonds in an extratropical region, the astronomical determination of positions, magnetic observations, and geological and botanical collections. The whole journey occupied nine months, and extended to 2320 miles, and is described in a work by Rose (2 vols. 1837-42) and in Humboldt's *Asie Centrale* (3 vols. 1843). The political changes of the year 1830 led to Humboldt's employment in political services; he was chosen by the king of Prussia to carry to Paris his recognition of Louis-Philippe, and during the ensuing twelve years was frequently sent to Paris to reside for four or five months. He accompanied the king of Prussia also in visits to England, Denmark, &c. During this time he published his *Essai Critique de la Géographie du Nouveau Continent* (5 vols. 1835-38). Humboldt spent the later years of his long life at Berlin, where he occupied a high position at the Prussian court. His last great work, *Cosmos* (4 vols. 1845-58), has been unanimously recognised as one of the greatest scientific works ever published, exhibiting in most lucid arrangement many of the principal facts of the physical sciences and their relations to each other. The style, however, is somewhat heavy, and, seen from our present standpoint, the author's views are in many respects defective. The germ of the work was the author's lectures in Berlin in 1828, themselves partially based on his *Ausichten der Natur* (1808). Humboldt died in his ninetieth year, May 6, 1859.

It is not easy to estimate the amount of Humboldt's contributions to science. The geography of Spanish-America was most imperfectly known previous to his travels there, during which he astronomically determined more than 700 positions, and he bestowed much labour on the preparation of the maps in which his discoveries were exhibited. His barometrical observations were likewise very numerous, as well as his observations on all points connected with meteorology. To him we are indebted for the most important generalisations concerning magnetism and also climate. He obtained distinction also by his labours in the determination of the magnetic equator, and by his observations on electrical eels, and on the respiration of fishes and young crocodiles. The editing and preparing of the great work of the American journey occupied twenty years of his life; and in his work he had the assistance of many of the most eminent scientists of the time Cuvier, Latreille, Gay-Lussac, Thenard, &c.—as well as the most distinguished artists and engravers. There is but one complete edition of the *opus magnum* (1807-17), in 30 vols. (20 folio and 10 quarto); the so-called small

edition being but excerpts. The title of the whole is *Voyages aux Régions Équinoxiales du Nouveau Continent, fait en 1799-1804 par Alexandre de Humboldt et Aimé Bonpland, rédigé par Alexandre de Humboldt*; and it falls into six sections, some of which and their parts are quoted as separate works (*Relation Historique, Observations de Zoologie, Observations Astronomiques, Physique générale et Géologie, Plantes Equinoxiales*, with atlases, essays, &c.). Humboldt is unquestionably one of the great figures of the century, and in private life was remarkable for benevolence and kindness, while his most conspicuous defect was vanity.

See the great biographical work, edited by Bruhns, *Alexander von Humboldt: eine wissenschaftliche Biographie* (1872; Eng. trans. 1873); and Lord Houghton's *Monographs* (1873). His correspondence with many of the most eminent men of the time has been published in many separate works—thus, that with Varnhagen (1800), with Von Raumer (1869), with Goethe (1876), with Campe (1877), with his brother Wilhelm (1880).

Humboldt, KARL WILHELM VON, the elder brother of the preceding, eminent as a statesman and for his works on philology, aesthetics, and general literature, was born at Potsdam, 22d June 1767, and educated at Berlin, Frankfurt-on-the-Oder, and Göttingen. He eagerly studied antiquities, aesthetics, and the Kantian philosophy, as well as law, to which he professedly devoted himself. After travelling in Germany, France, and Switzerland, he acquired the rank of counsellor of legation, but showed little inclination for official employment. In 1791 he married, and for some years resided chiefly on his wife's estate in Thuringia, and afterwards in Jena, associating most intimately with Schiller, and devoting himself to poetry and other literary and scientific pursuits. A valuable memorial of his friendship with Schiller is the correspondence between them. From 1797 to 1799 Humboldt resided partly in Paris and partly in Spain, and in 1801 became Prussian resident at Rome, where he remained for a number of years in this capacity, and in that of minister-plenipotentiary, a most generous patron of young artists and men of science. From Rome he returned to his native country to fill the high place of first minister of Public Instruction. The Berlin university owed its existence to him. In 1810 he went to Vienna as minister-plenipotentiary, and from this time he took part in all the most important political affairs in which his country was concerned. After 1819 he resided chiefly at Tegel, where he laid out fine pleasure-grounds, and formed a noble collection of sculptures by the greatest masters. He died 8th April 1835.

His earliest literary works were collected by himself under the title of 'Æsthetic Essays' (*Æsthetische Versuche*, 1799). His 'Collected Works' appeared in 7 vols. (1841-52). Humboldt devoted himself with the greatest assiduity to the study of philology, and was the first to make the study of the Basque tongue a scientific pursuit. He also spent much labour on the languages of the East, various questions connected with oriental literature, and the languages of the South Sea Islands. One of his most important works is on the Kawi language in Java (3 vols. 1836-40), published after his death by Edward Buschmann: the introduction to this, On the Variety of Structure in Human Speech, and his reflections on the influence thereof on the intellectual progress of mankind, mark a new era in the science of philology. *Letters to a Female Friend* (1847; Eng. trans. 1849) exhibit his character in a most pure and amiable light. See the admirable biography by Haym (1856), and his correspondence with Schiller (1830; new ed. 1876), Goethe (1876), Körner (1879), and his brother Alexander (1880).

Hume, DAVID, philosopher and historian, was born at Edinburgh on the 26th of April 1711 (o.s.). His father was the laird or proprietor of the estate of Ninewells, in Berwickshire, but David, being the younger son, had to make his own fortune with no other assistance than an education and the influence of his respectable family. He was educated at home and at the university of Edinburgh. His father designed law as his profession, and he submitted to the initial steps of the proper practical training, but it was not a pursuit to his liking. Deserting it, he made experiment of a mercantile life in Bristol; but commerce was not more congenial to him than jurisprudence, and he gave it a very short trial. He now became a student, devoting himself to books with no settled practical object before him. He has recorded his sufferings at this time from despondency and depression of spirits, caused apparently by the effects of monotonous study. At twenty-three years of age he went to France and lived some time in La Fleche, where he describes himself as wandering about in solitude, and dreaming the dream of his philosophy. In 1739 he published the first and second book of his *Treatise on Human Nature*—the germ of his philosophy, and still perhaps the best exposition of it, since it has there a freshness and decision approaching to paradox, much modified in his later works. Although the dawn of a new era in philosophy, this book was little noticed; in his own words, 'it fell dead-born from the press.' It was a work of demolition. By separating the impressions or ideas created on the thinking mind by an external world from the absolute existence of that world itself he showed that almost everything concerning the latter was taken for granted, and he demanded proof of its existence of a kind not yet afforded. It was thus that he set a whole army of philosophers at work, either to refute what he had said, or seriously to fill up the blanks which he discovered: thus he gave the original impulse both to the Scottish school of philosophy—Reid, and the rest—and to Kant's speculations. In 1741 and 1742 he published two small volumes called *Essays Moral and Political*; they were marked by learning and thought, and elegantly written, but are not among the more remarkable of his works.

He felt keenly at this time the want of some fixed lucrative pursuit, and his longing for independence was the cause of a sad interruption to his studious and philosophical pursuits. He was induced to become the companion or guardian of an insane nobleman, and had to mix with the jealousies and mercenary objects of those who naturally gather round such a centre. In 1747 he obtained a rather more congenial appointment as secretary to General St Clair, whom he accompanied in the expedition to the coast of France and the attack on Port L'Orient, the depot of the French East India Company; this affair had no important results, but it gave Hume a notion of actual warfare. Next year he accompanied the general in a diplomatic mission to France, and as he travelled he took notes of his impressions of Holland, Germany, and Italy, which are published in his *Life and Correspondence*.

In 1751 he published his *Impugnatio into the Principles of Morals*, a work of great originality, and one of the clearest expositions of the leading principles of what is termed the utilitarian system. At the same time he intended to publish his *Dialogues concerning Natural Religion*; but his friends, alarmed by the sceptical spirit pervading them, prevailed on him to lay them aside, and they were not made public until after his death. In his thirty-fifth year he had unsuccessfully competed for the chair of Moral Philosophy in Edinburgh, and at this period we find him unsuccessful in an attempt to obtain the chair of Logic in Glasgow.

Next year, in 1752, appeared his *Political Discourses*. Here, again, he made an era in literature, for in this little work he announced those principles of political economy, comprehending the doctrine of free trade, which it fell to his friend Adam Smith more fully and comprehensively to develop. He was appointed at this time keeper of the Advocates' Library, with a very small salary, which he devoted to a charitable purpose. It was here that, surrounded with books, he formed the design of writing the history of England. In 1754 he issued a quarto volume of the *History of the Stuarts, containing the Reigns of James I. and Charles I.*, and presently completed this portion of the work in a second volume, bringing it down to the Revolution. The second volume attracted more notice than the first had done. He then went backwards through the House of Tudor, and completed the work from the Roman period downwards in 1762. While so employed he published *Four Dissertations: of the Natural History of Religion; of the Passions; of Tragedy; of the Standard of Taste* (1757). Two other dissertations, intended to accompany these, were cancelled by him after they were printed—they are *On Suicide* and *The Immortality of the Soul*, and were subsequently printed in his works.

In 1763 he went to France as secretary to Lord Hertford's embassy; here he was in his element, and found fame at last. He became familiar with the brilliant wits and savants of the Parisian circle—with Turgot, D'Alembert, Helvetius, Holbach, Diderot, Buffon, Malesherbes, Crébillon, and the rest, as well as with the hardly less distinguished women, De Bonniers, Du Deffand, and L'Espinasse. His sojourn in Paris was unfortunate in bringing him into intimacy with the restless, vain, and self-tormenting Rousseau, who, after experiencing much substantial kindness from Hume, got suspicious, and forced him into a memorable quarrel. After his return home, in 1766, he accepted the responsible office of Under-secretary of State for the Home Department. In his own Life he says: 'I returned to Edinburgh in 1769 very opulent (for I possessed a revenue of £1000 a year), healthy, and, though somewhat stricken in years, with the prospect of enjoying long my ease, and of seeing the increase of my reputation.' His health gave way in 1774, and he died at Edinburgh, 25th August 1776.

Hume is the outcome of the empirical philosophy of Locke. His philosophical writings do not form a system, but discuss many of the salient ideas of philosophy, mainly in a sceptical or destructive manner. Ideas are but weakened copies of 'impressions' of the senses, outer or inner; mind is a succession of isolated impressions and ideas; the idea of cause depends on the habit of mind which expects the event that usually follows on another, and there is no necessary connection between cause and effect. Hume's History, which gives him a high rank among English historical authors, was not remarkable for historic impartiality (in a later edition more than a hundred alterations on the reigns of the first two Stuarts were made by Hume himself, and all to the Tory side), and has been largely superseded by more modern works; but new editions, with or without the continuation by Smollett, still appear; Dr Brewer's *Student's Hume* (1858) being a recognised text-book. Hume's position in relation to his predecessors and successors is given under BERKELEY; the article CAUSALITY is largely concerned with the discussion of his views. For the influence of Hume's scepticism in awaking Kant from his dogmatic slumber, see KANT. The most important edition of Hume's works is that by T. H. Green and T. H. Grose (4 vols. 1874), with introduction and exhaustive analysis of Hume's philosophy. *The Life and Correspondence of David Hume* was published by J. Hill Burton (2 vols. 1846); Dr G. Birkbeck Hill edited *Letters of David Hume to William Strathairn*, with copious and valuable notes, in 1889. For his theological position, and his relation to Edinburgh society, comprehended by his 'infidelity,'

see Leslie Stephen's *English Thought in the Eighteenth Century* (1876), the autobiography of 'Jupiter' Carlyle, &c. There are short monographs by Prof. Huxley ('English Men of Letters' series, 1879), Prof. Knight ('Philosophical Classics' series, 1886), and Prof. Calderwood ('Famous Scots' series, 1898); and German works by Jodl (1872), E. Pfeleiderer (1874), and Gizeycki (1878).

Hume, JOSEPH, politician, was born 22d January 1777, at Montrose. He studied medicine at Edinburgh, and in 1797 became assistant-surgeon in the service of the East India Company. He applied himself to the acquisition of the native languages, and during the Maharratta war, from 1802 to 1807, filled some half-dozen important offices, chief amongst which were those of interpreter and commissary-general. On the conclusion of peace he returned to England in 1808, his fortune made. Becoming imbued with the political philosophy of James Mill and Bentham, he gained admission to parliament, sitting as member for Weymouth, Aberdeen, Middlesex, Kilkenny, and Montrose successively, this last from 1842 to his death, which occurred on 20th February 1855. 'An uncompromising honesty, an instinctive hatred of abuses, an innate love of liberty, and an unflinching will to extend its benefits to others—these, and the close experience of men derived by himself during the earlier part of his life, rendered Mr Hume one of the most powerful, and at the same time one of the most practical, of reformers in a reforming age. Amongst the schemes and reforms he advocated may be enumerated the establishment of savings-banks, freedom of trade with India, abolition of flogging in the army, of naval impressment, and of imprisonment for debt, repeal of the act prohibiting export of machinery, and of that preventing workmen from going abroad, reduction of election expenses, abrogation of duties on paper, and removal of abuses of all and sundry kinds whatsoever. He was also chief agent in discovering the treasonable designs of the Orange lodges, which proposed to make the Duke of Cumberland king on the decease of William IV.

Hume, PATRICK (1641–1724), an eminent statesman and covenanter, Lord Chancellor of Scotland, who in 1690 was created Lord Polwarth, and in 1697 Earl of Marchmont. See BAILLIE (LADY GRIZEL).

Humeral, an oblong scarf worn by priests and subdeacons round their shoulders at certain parts of the service of the Mass and of Benediction, the paten, pyx, or monstrance being also wrapped in it (so as to prevent contact at those times with naked hands).

Hummel, JOHANN NEPOMUK, pianist and musical composer, was born at Presburg, 14th November 1778. He first studied under Mozart, and then, after a seven years' concert tour in Germany, Denmark, England, and Holland, he returned to Vienna to complete his musical education under Albrechtsberger and Salieri. From 1803 to 1811 he held the post of musical director to Prince Esterhazy; and in 1816 he filled a similar position at Stuttgart, but moved four years later to Weimar, where he died, October 17, 1837. In the course of several musical tours he delighted the capitals of Europe with his pianoforte playing and his clever improvisations on that instrument. Of his musical compositions the only ones which have value at the present day are his pianoforte works.

Humming-bird (*Trochilus*), a Linnæan genus of birds, now constituting a family, Trochilidae. The nearest relations of the humming-birds are the Swifts (q.v.); that they form together with the swift one large group is clear from their very close resemblances in anatomical structure. Nitzsch, Huxley, Gariod, and others who have investigated

the osteology, muscular anatomy, and other points concur in this opinion as to the relationship of the family; they resemble in their habit and in brilliancy of plumage the Sun-birds (q.v.), which replace them in the eastern tropical regions. The dazzling brilliancy of humming-birds, the extreme rapidity with which they dart through the air, their hovering above the flowers from which they obtain their food, with humming sound of wings, which move so quickly as to be indistinctly visible, or 'like a mist,' have attracted universal admiration since the first discovery of America. The diminutive size of almost all of them—some of them being the smallest of birds, and if stripped of their feathers not larger than a humble-bee—has still further contributed to render them objects of interest, whilst the plumage of the different species exhibits an almost endless variety of colours. Some species possess 'the most gorgeously brilliant metallic hues known among created things:' some on the other hand are sombre

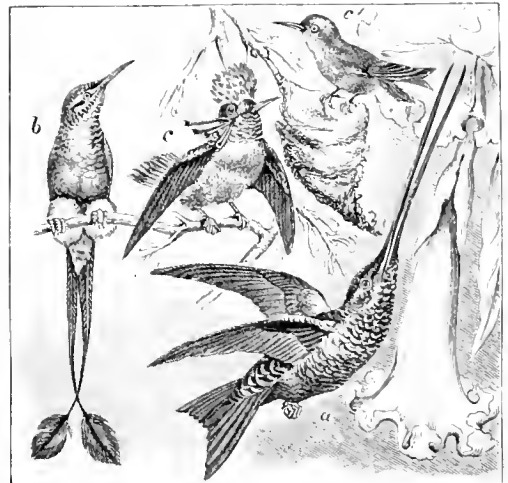

a, Sword-bill Humming-bird (*Docnaustes cusifer*);
b, White-booted Racket-tail (*Steganurus Underwoodi*);
c, c', male and female Tufted Coquette (*Lophornis ornatu*).

in hue. Humming-birds are entirely confined to the American continent and West Indies, where there are about 120 genera, containing over 400 species; no less than 15 species occur in North America. Of the South American forms the majority inhabit the hotter regions, but some are confined to elevated mountain-tracts even above the snow-line.

Humming-birds have slender bills, which are also generally long, and in some extremely so, the form of the bill exhibiting a wonderful adaptation to the kind of flowers from which the bird obtains its food—straight in some, curved in others. Humming-birds do not, as was long supposed, feed on honey alone, but to a considerable extent, and some of them perhaps chiefly, on insects, not rejecting spiders, whilst they often snatch away the insects which have become entangled in spiders' webs. The tongue is very long, capable of being darted out to a considerable length; the bone of the tongue (hyoid bone) being much elongated, and its branches passing round the back of the skull to the forehead, where they meet in a point before the line of the eyes. The tongue itself consists of two hollow filaments, joined together for the greater part of their length, and separated at the tip; the structure of the tongue and hyoid bones is curiously like that of the Woodpeckers (q.v.) and the sun-birds already referred to; this affords an illustration of the fact that similar requirements often cause

development of similar structures in animals otherwise distinct. The wings of humming-birds are very long and powerful, like those of the swifts, the length being particularly marked in that portion of the wing which corresponds to the hand of mammals; hence the name *Macrochires* which is applied to the group. Humming-birds construct their nests with nice art, generally of lichens and of fibrous substances, such as cotton. They do not lay more than two eggs. They are very bold in defence of their nests and young, and are said to strike fearlessly with their needle-like bills at the eyes of birds of prey, which they far surpass in agility and rapidity of flight. They are very easily tamed and rendered familiar, and have been known to return again in spring, after a winter migration to a warmer climate, to the window from which they had been allowed to escape. Attempts to keep tamed humming-birds have generally failed; and they have almost never been brought safely across the Atlantic. Humming-bird skins were anciently used by the Mexicans for making pictures.

See John Gould's magnificent *Monograph on the Trochilidae* (5 vols. 1849). Gould's collection of specimens was bought for the British Museum.

Humming-bird Moth. See HAWK-MOTH.

Humours, Humoral Pathology. See TEMPERAMENT, HIPPOCRATES.

Humperdinck. ENGELBERT, composer, was born at Siegburg, near Bonn, 1st September 1854; and after studying music at Cologne, Frankfort, Munich, &c., and travels in France, Spain, and Italy, taught in the conservatoriums of Barcelona and Cologne, and was musical adviser to a publishing firm in Mainz. Wagner summoned him to assist in the production of that master's only symphony; and it was he who prepared and coached the first cast of *Parsifal* at Baireuth (1882). He subsequently settled in Frankfort (1890), and became famous as the author of the phenomenally successful children's opera or musical fairy play, *Hansel and Gretel* (1894), which was followed by *Schneewittchen* ('The Snow Maiden') and *The Royal Children*.

Hunchback. See SPINAL COLUMN.

Hundred. In English law, an ancient subdivision of counties, the name of which probably arose from there being a hundred warriors, or perhaps a hundred families, or ten tithings, in each (see FETTERALISM). In ancient times, if a crime was committed, such as robbery, maiming of cattle, burning of stacks, &c., the hundred had to make it good. The old distinctions have, however, now less significance. But the characteristic of a hundred is still this, that it has a constable or bailiff, and when any damage is done by rioters feloniously destroying property the owner has his remedy by suing the hundred for the damage. In order to secure this remedy the party or his servant must, within seven days, go before a justice, and engage to prosecute the offenders, when apprehended. So, where there is no hundred, the county, or city, or town is liable in like manner. Execution is levied on the treasurer of the county. In the northern counties a hundred was called a wapentake (Yorkshire) or a ward. See RIOT, COUNTY.—The townships in Delaware, U.S., are also called Hundreds. See Professor G. E. Howard's *Introduction to the Local Constitutional History of the U.S.* (Baltimore, 1889).

The Hundred Days is a name often given to the period between Napoleon's landing in France after his escape from Elba (1st March 1815) and the battle of Waterloo (18th June 1815). See FRANCE, NAPOLEON I.

Hungary (Hung. *Magyarország*, Ger. *Ungarn*, Lat. *Hungaria*) is the eastern and larger half of

the Austro-Hungarian monarchy, covering an area of about 125,000 sq. m., between 44° 10' and 49° 35' N. lat., and between 14° 25' and 26° 25' E. long. Comprising Hungary proper, Transylvania, Croatia and Slavonia (nominally also Dalmatia), and Fiume, it forms the realm of the crown of St Stephen or Transleithania, which is a coequal factor with Austria or Cisleithania in the empire-kingdom ruled over by the Hapsburg dynasty. The two states form a union under one monarch for military, diplomatic, and customs purposes, but otherwise retain their distinct independence of each other. The form of its government as well as its geographical, industrial, and statistical features having been dealt with in the article AUSTRIA, it now remains only to give an account of the history, language, and literature of the country, or its chief and ruling inhabitants, the Magyars.

History.—But little is known of the history of the Hungarians previous to their appearance in Europe in 884. They are generally believed to be the descendants of the Scythians, and to have come from regions about the Caspian Sea. They first settled along the Middle Volga, but, having been pressed westwards, they in 889 crossed the Carpathian Mountains under Almos, and under the further leadership of his son Arpad they conquered the ancient Pannonia and Dacia of the Romans; and this, their new country, was in the year 1000 formed into a regular kingdom by Stephen. For his merits in Christianising his people Stephen was afterwards created a saint, and received from Pope Sylvester II. the title of 'apostolic king' and a crown, both of which have been worn by all the kings of Hungary to the present day. The Hungarians were at first an extremely warlike and even savage tribe; and, not content with subduing the various nationalities inhabiting the ancient Roman provinces, they made frequent expeditions into Germany and Italy, destroying the early results of Christian civilisation. All this, however, ceased on, and even before, the accession of Stephen, who turned his attention solely to the consolidation of Christianity and interior order and prosperity. He laid the foundation of many institutions surviving to the present day, such as the ecclesiastical organisation, the archbishoprics and bishoprics, the municipal and county councils, and even the national council, which eventually developed into the Diet of the States. Within two decades after his death (1038) two attempts were made to overthrow Christianity, and to re-establish Paganism, but only with very slight and temporary success. Under Bela I. (1061-63), Ladislaus the Saint (1077-95), and Coloman the Learned (1095-1114), the country made very marked progress. The reign of Andrew II. is remarkable on account of the nobles having extorted from him in 1222 the 'Golden Bull,' or Hungarian Magna Charta, the privileges of which were in 1231 extended to the clergy and lower nobility. The 'Golden Bull' conferred many personal and material advantages on the nobles, and also contained a guarantee for the annual convocation of the diet; it conceded the right of armed resistance to any illegal acts of the king. During the reign of Bela IV. (1235-70) Hungary was devastated by a terrible Mongol invasion. To replace part of the population cruelly massacred by the Asiatic savages, Bela introduced German colonists; hence the German-speaking communities in Hungary to the present day. By the death of Andrew III. in 1301 the House of Arpad became extinct, and the throne of Hungary became an object of rivalry between various foreign potentates. After many vicissitudes, Hungary was fortunate enough to find a worthy king in the person of Charles Robert of Anjou (1308-42),

who did much to place his adopted country on a level with more civilised western nations. His son, Louis the Great, made Hungary the most powerful nation of the period in central Europe. After the death of Ladislaus Posthumus (1457), Matthias Corvinus, the son of Hunyady, the great anti-Turkish hero and regent during that king's minority, was elected king. Under his reign Hungary attained to the pinnacle of fame, prosperity, civilisation, and power. He waged successful wars against Podiebrad of Bohemia, and got himself crowned king of Bohemia and Moravia. He also defeated the Turks at Kenyérmező, and reconquered the southern provinces held by them. In 1485 he even took Vienna and made it the capital of his country, which was at that time more extended than ever before or after. But Matthias was not only a great general; he was also a great legislator, a munificent patron of art and sciences, and a great judge. His impartiality and love for the people were so generally recognised that to the present day there lives in Hungary the proverb: 'King Matthias is dead; there is no more justice.' Matthias having died without legitimate heirs, the throne of Hungary again became the object of fierce struggles between various pretenders, and the country underwent in consequence a period of rapid decay. Under Vladislaus (1490-1516) Hungary was the scene of a sanguinary peasant insurrection, known as the *Dozsa* revolt, which was ultimately suppressed, and led to a system of abject serfdom. Louis II.'s reign was still more disastrous. The Turks, under Soliman the Great, took advantage of the enfeebled condition of the country, invaded it with a gigantic army, annihilated the Hungarian forces at Mohács, pillaged whole districts, including Buda with the world-famous *Bibliotheca Corvina*, and carried off some 30,000 Hungarians as slaves. Louis II. himself lost his life in or after the battle of Mohács, and the Hungarian throne became once more the prize of contention between two claimants. One was John Zápolya, Voivode of Transylvania, whom one section of the nobles proclaimed king, the other was Ferdinand of Austria, brother-in-law of Louis II. Zápolya was supported by the Turks, Ferdinand by the majority of the Hungarian nobles. Eventually Zápolya surrendered his claims to the whole kingdom, merely retaining Transylvania and the Transylvanian district of Hungary for life. Thus the Hapsburgs obtained at length a final footing in Hungary, and the country entered on a period of endless suffering and humiliations.

The successors of Ferdinand—viz. Maximilian, Rudolph, Ferdinand II., Ferdinand III., and Leopold I.—when they were not engaged with the Turks, concentrated their energies on the suppression of Protestantism in Hungary. The Protestants won several victories over the Imperialists, as in 1604-6 under Stephen Bocskay, in 1620-21 under Bethlen Gabor, in 1644 under George Rákóczy, thus forcing the government to show more toleration towards the followers of the new religion; but the kings being under Jesuit influences, all treaties and promises were broken on the first opportunity. Especially ruinous was the long reign of Leopold I. (1657-1705), who, with the most merciless determination, used all means at his disposal, as he himself said, to 'impoverish, enslave, and recatholicise' Hungary. Some of his own highest office holders, although themselves Catholics, so much resented his terrible treatment of the Protestants that they began a conspiracy for the separation of Hungary from the Hapsburg dominions; but the plot having been detected, the ringleaders were put to death. For many years the scaffolds were at work in sus-

pected districts, and thousands of valiant families, mostly Protestants, were exterminated. A Protestant rising, under Count Emeric Toköly, and supported by Kara Mustapha, proved very successful in 1683, and very nearly led to the capture of Vienna and the utter destruction of Austria; but at the last moment John Sobieski, king of Poland, saved Vienna and the Hapsburgs. After the retreat of the Turks from Vienna they gradually lost their hold on Hungary.

Leopold died in 1705 amidst the anxieties entailed upon him by another Hungarian rising, led by a second Francis Rákóczy, which did not end before 1711. Leopold succeeded in causing the diet to declare the throne hereditary in the House of Hapsburg, and Charles VI. (1711-40) received their adhesion to the Pragmatic Sanction, securing the right of succession in the female line. Nevertheless, his daughter Maria Theresa's claim to the throne was called in question by several German rulers and by France, her dominions were invaded, and she saved them and herself only through the magnanimous self-sacrifice of the Hungarians. She was the first Hapsburg ruler who showed herself grateful to the Hungarians, and who proved herself to understand the duties of a sovereign. She made several concessions to the Protestants, improved the condition of the peasants, and established schools. Her son and successor, Joseph II. (1780-90), does not strictly figure among Hungarian kings, as he had never himself been crowned in Hungary, but carried on his reign in violation of the Hungarian constitution as an autocratic emperor. He was an enlightened reformer, but did not reckon with national feelings, class idiosyncrasies, interests, and prejudices; he attempted to make Hungary part of a vast pan-Germanic bureaucracy; and many of his measures fostered the discontent to such a degree that at his death he saw himself compelled to recall all his illegal edicts, with the exception of one—viz. that enjoining religious toleration. Leopold II. at once convoked the diet (the first for twenty-five years), and confirmed the rights and independence of the nation. His conciliatory reign lasted only two years, and he was succeeded by Francis I. (1792-1835), whose ambition it was to follow the example of his least reputable predecessors. As long as the Napoleonic wars lasted, and the Hungarians supported him with money and troops, he played at constitutionalism; but as soon as the Napoleonic dangers were passed he showed himself in his true character, discontinued the diets and levied troops and taxes at his pleasure till 1825, when he was driven by the general discontent and resistance to convolve the states.

This diet marked the beginning of the new era in Hungary. The nation commenced to awaken to the consciousness of its many wants, intellectual and material; the desire for reforms was fast ripening. The majority of the delegates to the next diet (1832) were already bearers of radical instructions. The desired reforms, however, were slow in coming, owing to the narrow-minded policy of Metternich and the whole court party. The diet of 1832 counted among its members such men as Count Louis Batthányi, Baron Nicholas Wesselényi, Baron Joseph Eötvös, Francis Deak, and Louis Kossuth. The more important reforms passed by this and the subsequent diets of 1839 and 1843 were those regarding the official use of the Hungarian language, the eligibility of non-nobles to public offices, and the equal rights of Christian denominations. Outside parliament there was no less activity than inside. Kossuth's *Pesti Hírlap* (the first Hungarian political daily paper), which in enthusiastic language taught the masses how to demand their rights, rapidly spread all over

the country. Kossuth advocated the abolition of serfdom, the equality of all citizens, the liability of nobles to taxation, and freedom of the press. He was returned to the diet of 1847 as senior member for the county of Pest, and it was on his motion that the House resolved in March 1848 to send a deputation to Vienna to demand all these and various other reforms. Ferdinand V., a weak-minded man, who had reigned since 1835, yielded after some hesitation, and the first Hungarian responsible ministry entrusted with the task of carrying the said measures was appointed. Count Louis Batthányi was prime-minister, Peak minister of justice, and Kossuth minister of finance. But the court party were secretly determined to frustrate all these reforms, which openly they did not dare to oppose. They therefore incited the Croats and other non-Hungarian nationalities to rise against Hungarian supremacy. Accordingly Croatia, Slavonia, the Serbian Banat, and eventually the Roumans of Transylvania took up arms against Hungarian rule; and when the central government in Vienna was appealed to it issued highly-worded proclamations against the rebels, but gave very scant help to subdue them, whilst secretly it supplied them with arms, ammunition, and money. The Hungarian government, so treacherously abandoned, proceeded to obtain from parliament the vote of a levy of 200,000 men and 42 million florins of money, but to these measures, unanimously decreed by parliament, the crown withheld its assent. Later on, September 6, when a deputation of 120 members waited on Ferdinand to urge him to oppose the Croatian invasion, the court again gave an evasive reply. But a few days later, having received good news respecting the army operating in Italy, the court threw aside the hypocritical mask hitherto worn, and declared open hostility to Hungary by ignoring the existing constitution and government, recalling the Palatine Archduke Stephen, and appointing Count Lamberg governor-general and royal commissioner for Hungary. Parliament declared these acts illegal, and Count Lamberg was murdered on his arrival by the enraged population of Budapest. The ministry now resigned, and a committee of national defence was appointed with Kossuth as president. A comparatively numerous army was rapidly equipped and sent to meet Jellachich, who was marching towards Budapest at the head of the Croats. He was completely beaten at Velencez, and during an armistice of three days, which was granted him by the victorious Hungarians, he fled ignominiously towards Vienna. Notwithstanding this defeat he was appointed commander-in-chief of all the forces and alter-ego of the emperor-king in Hungary; and all the decrees and resolutions of the Hungarian parliament were declared illegal.

On December 2 Ferdinand was compelled by a family council to abdicate in favour of his nephew, Francis-Joseph, who was then eighteen years of age. In his name the war began to be carried on bitterly against Hungary, all the more as the diet declared the succession unconstitutional. Up to the middle of January next fortune seemed to favour the Austrian arms: the Hungarians, though they fought valiantly and obtained some victories, had to retreat before the overwhelming numbers of the enemy; the whole trans-Danubian district and the north and south were lost to them; they had only the vast plains of the Alföld and Transylvania, where Bem entirely subdued the rebellious nationalities. Meanwhile the Russians were also coming to the aid of the Austrians, so that the Hungarians had fair reason to despair of their own position. It was only the inactivity of Windischgratz, the new Austrian generalissimo, that

saved the Hungarians. His aimless stay at Budapest gave Kossuth time to perambulate the country, and by his stirring eloquence and boundless energy to create a splendid though irregular army, which, under the various leadership of Dembinski, Vetter, Görgei, Klapka, and others, won so many victories over the Austrians within the next three months that by the end of April the country was almost entirely free from the enemy. The many defeats of the Austrian regular forces by the Hungarian irregulars so exasperated the Vienna court that, on March 4, 1849, it promulgated a decree abolishing the Hungarian constitution; to which the Hungarian diet replied by the declaration of independence, and the dethronement of the Hapsburg dynasty on April 14. No final form of government was decided upon, but Kossuth was temporarily elected governor-president, and instead of the committee of national defence a new ministry was formed under the presidency of Bartholomew Szemere. Had Görgei not disregarded Kossuth's advice, had he forced his way to Vienna after so many victories, the whole war might have come to an end with glorious results for Hungary; but Görgei decided to first retake Budapest, and thereby enabled the united Russian and Austrian armies to invade the country at various points. These combined armies consisted of no less than 275,000 men, with 600 batteries, whilst the Hungarians numbered barely 135,000, with no artillery to speak of. In these circumstances the Hungarians had little chance of defending themselves with any measure of success, but they continued to fight with the greatest determination. Fortune still smiled on them here and there, but on the whole chances and events were against them. This decline of their fortunes was aggravated by the serious dissensions between Görgei and Kossuth, which grew daily in intensity till the latter thought it advisable, in order not to hamper the other's strategic activity, to abdicate in favour of Görgei on August 11, 1849. Once in the possession of the chief political and military power, Görgei no longer thought of continuing the struggle, but immediately and unconditionally surrendered himself to the Russians. This act on his part was defended by him as one imposed by necessity and a saving of further bloodshed; but examined in the light of his former conduct and of the fact that he induced, by empty and futile promises for the safety of their persons and their troops, thirteen other generals to follow his example, it is generally considered by the majority of his countrymen an act of unpardonable treason. Kossuth and several other military and political leaders fled to Turkey, whilst the others who remained behind and were captured were either sentenced to long terms of imprisonment or shot and hanged like mere criminals. Among the latter were Count Louis Batthányi and the thirteen generals betrayed by Görgei, including Count Charles Leiningen, a relative of the Queen of England. Görgei himself was sent to Klagenfurt, and kept there on a small pension. Hungary was incorporated into and governed as an hereditary province of Austria, the governor being General Haynau, who wielded his official power with extraordinary harshness and cruelty. Political prisoners were tortured, women publicly flogged, properties and rights confiscated. With the exception of the abolition of serfdom all the acts of the diet of 1848 were annulled, and Hungary was governed by a host of foreign officials according to Austrian laws and institutions. The country displayed no active resistance, nevertheless all the efforts of this centralising and Germanising system so completely failed that by 1857 the Vienna government began to see its futility and to offer some concessions.

After the disastrous Italian war in 1859 the old Hungarian chancellery, as it existed previous to 1848, was re-established, but failed to satisfy the Hungarians, whose passive resistance threatened with a final breakdown the Austrian state machinery. At length in 1861 the diet was once more convoked; but, as it demanded the full restitution of the constitution of 1848, it was quickly dissolved. Gradually, however, better counsels prevailed at the court of Vienna. Parliament was again summoned in 1865, and the demands of the Hungarians, as formulated by Deak and his party, were complied with, and resulted in the agreement described in detail in the article AUSTRIA. Francis-Joseph was crowned king of Hungary, June 7, 1867, and entered on the faithful discharge of his duties as constitutional monarch. There is still a numerous party in Hungary in favour of complete separation from Austria, but none are hostile to the sovereign. The renewal of this decennial financial arrangement (1897-98) led to very strained relations between the two sections, the Hungarians declining to raise their contributions from 31·4 to 42 per cent. of the common expenditure. Hungary made good use of the period of internal peace enjoyed after the coronation, and made rapid strides in the path of civilisation. It established an admirable system of elementary and higher education, built a magnificent net of railways (now largely in the hands of the state), improved its judicature, developed commerce and industry, and organised, in addition to the Austro-Hungarian common army, an effective system of national defence, the Honvéds. Budapest, its capital, equalled by few, surpassed by none among the great cities of Europe, is watched with as much envy by the Austrians as the growing influence of the Hungarians in the common councils of the monarchy. Lately the former heavy deficits have disappeared from the budget, and there is every hope of the kingdom soon being in a condition to reduce its heavy debts. The various nationalities in Hungary (Servians, Wallachs, Ruthens, Slovaks, Germans) enjoy the same rights as the native Magyars, which are considerably greater than in Austria; there is therefore comparatively little discontent prevailing among them, even though panslavistic missionaries strive to make mischief. Much of Hungary's steady progress is due to the fact that since the new era there have been few changes in its government. The thousand years of national existence was celebrated by a millennial exhibition, historical processions, &c. at Budapest in 1896.

Language and Literature.—The Hungarians when they settled in their present land a thousand years ago brought their language ready with them, and this, although it has had since to borrow certain words from European languages to convey new ideas, has retained all its original features both as regards etymology and syntax. The origin of the Hungarian language can hardly be stated yet with certainty. Hungarian philologists are divided into two sections on the point, the 'Orientalists' maintaining its affinity with Turco-Tartaric languages, whilst the 'Finnists' contend, and for the present at least with far more general success, that it belongs to the Ugric branch of the Finnish group. By reason of the perfect harmony between vowels and consonants, and the very distinct articulation and pronunciation essential to it, Hungarian is considered a very musical language, particularly adapted to poetry and rhetoric. Its grammar, moreover, is so strikingly different from that of any other European language, and so rich in original characteristics, that it offers a very interesting field to students of comparative philology. It is acknowledged by them that it is well adapted to

express ideas with the utmost clearness, owing to the distinctness and immense variety of endings and the originality and flexibility of its roots. Among its characteristics are that it has no genders, and *declination* and *conjugation* are effected by means of suffixes only; that the verbs possess objective and subjective forms (e.g. *látok*, 'I see'; *látom*, 'I see him or her or it'; *látasz*, 'thou seest'; *látod*, 'thou seest him or her or it,' &c.); that it invariably places the surname before the Christian name. It is also noteworthy that there are absolutely no dialects in the Hungarian language, and scarcely any difference of pronunciation in the various parts of the country.

From the date of the establishment of the Hungarian kingdom the use of the Hungarian language was so much restricted that a Hungarian literature can hardly be said to have existed before the close of the 18th century. The introduction of Christianity by Italian and German priests in the 11th century made Latin the official language and the medium of intercourse between the educated classes, and this remained so to a great, though gradually diminishing, extent up to the third and fourth decade of the 19th century. There was a slight reaction in favour of Hungarian after the Reformation, but the language was not taught in schools till the year 1790, and parliament did not discontinue Latin until 1825. The oldest Hungarian literary record extant is a funeral oration dating from the year 1171; there are also some religious songs and dramatic 'mysteries' from the 14th century. The first lay poet of real merit, Baron Valentine Balassa, lived in the second half of the 16th, the first great epic poet, Zrínyi, in the 17th century.

The revival of literature began to take place only towards the end of Maria Theresa's reign. Lyric poetry was cultivated by Anyos, Virág, Baesanyi, and by Alexander Kisfaludy (1772-1844), Daniel Berzsenyi (1776-1836), Francis Kazinczy (1759-1831), and others, who not only added to the valuable stock of literature, but also enriched the language with new words and forms—Kazinczy excelling so much in this respect as to obtain the appellation of 'the recreator of the language.' Kolessey, orator, essayist, and poet, and Charles Kisfaludy (1788-1830), the founder of Hungarian drama, were the chief literary figures at the beginning of the 19th century. Hungarian poetry, however, cannot be said to have possessed much originality at this period; it was reserved to such men as Petöfi (1823-49), Vörösmarty (1800-55), Arany (1817-82), and Tompa (1819-68) to regenerate Hungarian poetry on national lines. This end was attained towards the period of the war of independence, since which Hungary has produced a number of minor poets, such as Sarosy, Szász, Vajda, Kiss, Reviczky, Abrányi, and Rudnyánszky. In dramatic literature Charles Kisfaludy was followed by Szigligeti (1814-78), whose extreme fertility enriched it by many exceedingly successful plays. The classic tragedy *Bánk Bán* of Katona (1792-1830), and *The Hunian Tragedy*, a dramatic poem, by Madach (1823-64), on the lines of Goethe's *Faust*, but no less original, deserve especial mention. Amongst their successors there is only one great dramatist—Gégor Csiky. The Hungarian theatres rely mainly on products of foreign literature—French, English and German.

In prose literature Hungary has produced many standard works. The founder of the real Hungarian novel was Baron Nicholas Josika (1794-1865), whose historical and social novels on the model of Sir Walter Scott's works achieved great success and popularity. Baron Joseph Eötvös (1813-71) cultivated the sentimental novel, and the novel with a purpose. But among authors of

fiction the highest rank is due to Maurice Jokai (q.v.), whose boundless imagination and profound humour have rendered him a favourite with readers in many countries beyond his own. Almost all his novels have been translated into German, many into Italian, French, English, and other languages. Beyond its own original productions it also possesses admirable translations of all the masterpieces in the world's literature, from the Bible, of which it possesses three versions, down through all ages and countries to Tennyson's poems. A collection of Shakespeare's plays is especially noteworthy, they having been translated by Hungary's greatest poets, including Petöfi (*Coriolanus*), Arany (*Hamblet, Midsummer-Night's Dream, King John*), Vörösmarty (*King Lear*), and others. It should be added that the best literary talent of the country is to a great extent connected with journalism.

See Fessler, *Geschichte der Ungarn* (new ed. by Klein, 1863-87); Majlath, *Geschichte der Magyaren* (2d ed. 1853); Sayous, *Histoire des Hongrois* (Par. 1876), and works by Horváth, Szalay, Toldy, &c.; also Vambéry, *Story of Hungary* (1886); Leger, *History of Austro-Hungary* (trans. by Mrs Birkbeck Hill, preface by Freeman, 1890); and Felbermann, *Hungary and its People* (1892).

Hunger. See APPETITE, DIGESTION.

Hungerford, a town of Berkshire, partly also in Wiltshire, is situated on the river Kennet, 26 miles WSW. of Reading. It is a hunting centre, and a favourite resort of anglers, having been even in Evelyn's time 'a town famous for its troutes.' In the town-hall (1870) is preserved a horn gifted to the town by John of Gannet in 1362. Pop. 2965.

Hünningen (Fr. *Huningue*), a town of Alsace, on the left bank of the Rhine, 2½ miles N. of Basel, is celebrated for its fish-breeding establishment (see PISCICULTURE). It was fortified by Vauban in 1679-81, but the works were finally destroyed in 1815. Pop. 1704.

Huns (Lat. *Hunni*, Gr. *Ounnoi* and *Chunnoi*), a nomad race of antiquity, whose remote ancestors were probably the Hing-nu, a people of Turki-h stock, who formed a powerful state in Mongolia in the 2d century B.C. In 177 they conquered another large nomad race, the Yue-chi, akin to the Tibetans, and drove them westward and southward, they themselves following. But about the dawn of the Christian era their political power fell to pieces and the tribesmen were scattered. One section, however, seems to have fled westwards and to have settled in the neighbourhood of the river Ural and the Volga. At all events, some three centuries and a half later the people known to classic and mediæval writers as Huns stepped upon the stage of history from that part of the world. About the year 372 they moved westwards again, under a leader called Balamir, and subdued first the Alani, who dwelt between the Volga and the Don, and then proceeded to attack the Ostrogoths, part of whom submitted somewhat tamely, whilst another part offered strenuous opposition, but were in the end compelled to submit likewise. This business completed, the Huns next invaded the territories of the Visigoths, and drove this people before them across the Danube, except one section, who, under Frithigern, sought permission of Valens, emperor of the East, to settle in his territories. The districts allotted by the Goths were occupied by the Huns. This, their first wave of invasion and conquest, seems then to have subsided; and, though it was followed by more than one smaller after-wave, it was not until about 430 that the second and greater wave began to gather head again in Rhnas or Rugulas. This chief acquired such power and influence that in 432 he imposed upon Theodosius II., emperor of Byzantium, an annual tribute of

350 pounds of gold. He was succeeded in 433 by his more illustrious nephew Attila (q.v.). With Attila's death, however, in 453, the power of the Huns crumbled to pieces amid the intestine strifes of his sons and generals, and the attacks of their foes round about. After a most disastrous defeat inflicted upon them in Pannonia in 454 by the combined armies of the Goths, Gepidae, Sævi, Herulians, and others, the tribesmen of the Huns rapidly dispersed. Some settled in the Dobrudja, others in Dacia, whilst the main body seem to have returned to the land from whence they came—viz. the region about the river Ural. Some authorities identify these with the later Bulgarians, who about the end of the 5th century had risen into a powerful state on the Volga, and sent off conquering bands to the south-west, who finally settled in the modern Bulgaria.

The Huns are described as being of a dark complexion, deformed in appearance, of uncouth gesture and shrill voice. 'They were distinguished,' says Gibbon, 'from the rest of the human species by their broad shoulders, flat noses, and small black eyes deeply buried in the head; and, as they were almost destitute of beards, they never enjoyed either the manly graces of youth or the venerable aspect of age. A fabulous origin was assigned worthy of their form and manners—that the witches of Scythia, who for their foul and deadly practices had been driven from society, had united in the desert with infernal spirits, and that the Huns were the off-spring of this execrable conjunction.' Like the Mongols, they were essentially a race of horsemen; they fought with javelins tipped with bone, with sabres, and with slings or lassoes. They ate herbs and half-raw meat, which they first used as saddles; and they clothed themselves with the skins of wild animals.

The White Huns or Ephthalites or Hephthalites are by some regarded as a branch of the Hing-nu, though others make them the descendants of the ancient Royal Scythians, identifying them with the Barsileens, the allies of the Khazars. Whatever be their real origin, they were certainly established in ancient Bactria and the adjoining districts, between the Oxus and the Caspian, at a period contemporaneous with Attila's career. From the third decade of the 5th century onwards for about 120 years they were engaged in constant wars with their neighbours on the south, the Persians. In 484 the Ephthalites routed them in a fierce battle, in which Peroz, king of Persia, was amongst the slain. But their power seems to have been finally broken about 560 by the all-conquering Turks on their way to Asia Minor and Constantinople.

See De Guignes, *Histoire Générale des Huns* (vol. i. 1756); Neumann, *Die Völker des südlichen Russland* (2d ed. 1855); Thierry, *Histoire d'Attila* (4th ed. 1874); and Howorth, in *Jour. Anthropol. Inst.* (1872-74).

Hunstanton, a watering-place of Norfolk, on the Wash, 18 miles NE. of King's Lynn by a railway (1862). It has a broad beach of firm sand, and good bathing and sea-fishing, a pier, and a splendid decorated church (c. 1330). Hunstanton Hall, dating from the Tudor period, but greatly injured by fire in 1853, was the seat of Sir Roger L'Estrange. A lighthouse (1840) lifts a fixed light to an altitude of 109 feet, and shows it for a distance of 16 miles. Pop., with Barrett Ringstead, 1725.

Hunt, HENRY, surnamed 'Orator Hunt,' was born at Upavon, in Wiltshire, on 6th November 1773. He was a well-to-do farmer, but in 1800 his hot temper embroiled him with Lord Bruce, the commandant of the Wiltshire yeomanry, which brought him six weeks' imprisonment. He came out of gaol a hot Radical, and spent the rest of his life travelling about the country addressing

the people on behalf of the repeal of the Corn Laws and as an advocate of parliamentary reform. In 1819, on the occasion of the Peterloo massacre, he delivered a speech, which cost him three years' imprisonment. He died at Alresford, in Hampshire, on 13th February 1835.

Hunt, JAMES HENRY LEIGH, poet and essayist, was born at Southgate, near Edmonton, on 19th October 1784. His father, Isaac Hunt (1752-1800), a Barbadian, being driven by the Revolution from Philadelphia to London, gave up law for the church, but lapsed into bankruptcy and Universalism. Leigh Hunt spent eight years at Christ's Hospital, and left at fifteen as first 'Deputy-Grecian,' debarred by a stammer from further promotion. He was a clerk first under one brother, an attorney, and next for four years in the War Office, writing meanwhile much dramatic criticism: in 1808 with another brother, a printer, he set up the *Examiner*; and in 1809 wedded Marianne Kent (1788-1857). The *Examiner's* tone was Radical, and, after several government prosecutions in 1813 for a libel on the Prince Regent (he had called him a 'corpulent Adonis of fifty'), Leigh Hunt was sentenced to a fine of £500 and to two years' imprisonment in Surrey gaol. There he 'scattered urbanity,' played battledore with his children, received hosts of visitors, and turned his cage into a 'bower of roses.' In November 1821 with his wife and seven children he sailed for Italy, but landed at Leghorn only on 1st July. He went on Shelley's invitation to help him and Byron to found the quarterly *Liberal*. Just a week later Shelley was drowned; Leigh Hunt and 'my noble friend' failed somehow to pull together; the *Liberal* died in its fourth number; and by 1825 the family was back at Highgate. Changes of residence, to Upper Cheyne Row, Chelsea, in 1833, to the 'old court suburb' of Kensington in 1840, and to Hammersmith in 1853—these are thenceforth the chief events in Leigh Hunt's life. It was one of ceaseless activity and as ceaseless embarrassment, for he *never* knew his multiplication table. From 1844, however, Sir Percy Shelley allowed him £120 a year, and in 1847 he received a pension of £200. He died on a visit to Putney, 28th August 1859.

The 'Cockney poets,' so the critics dubbed Keats and Leigh Hunt. That the two should ever thus have been bracketed may now seem strange, for Leigh Hunt's poetry now is little known. And yet it is better than much, maybe most, of the newer poetic vogues. Its charm lies in a prettiness as of childhood; its wit and cleverness and wine-like sparkle have ever a smack of precocity. Narrative verse is his forte, his foible jauntiness. His translations are among the choicest of their kind; he transports the southern vintages to England, and their colour and flavour improve instead of losing by the voyage. As his poems, so his prose; his essays are always worth reading, but only after the *Essays of Elia*. Leigh Hunt's writings, indeed, are less memorable than his friendships—with Keats and Shelley, as also with Lamb, Byron, Moore, Coleridge, Dickens, Carlyle, and a whole galaxy of lesser luminaries. Our knowledge of them, and especially the first two, is largely derived from his.

In his excellent *List of the Writings of Ha'ltitt and Leagh Hunt* (1868) Mr Alexander Ireland chronologically arranges with notes, &c., seventy-nine works by the latter, including *Jocundia* (1801), *The Feast of the Poets* (1814), *The Story of Rowan* (1816), *Fadlan* (1818), *Captain Swind and Captain Pen* (1835), and *The Palfrey* (1842); besides much in prose, as *Lord Byron and his Contemporaries* (1828), *See Ralph Esch* (1832), *Imagination and Fancy* (1844), *Wit and Humour* (1846), *Stories of the Italian Poets* (1846), *A Jar of Honey from Mount Hybla* (1848),

and *The Old Court Suburb* (1855). See Leigh Hunt's *Autobiography* (3 vols. 1850; revised ed. 1860) and *Correspondence* (2 vols. 1862), Forster's *Life of Dickens* (for the unkindly 'Harold Skimpole' episode), a capital article in the *Cornhill* (1. 1860), and one by Prof. Dowden in Ward's *English Poets* (iv. 1880); and sketches by Cosmo Monkhouse (1893) and B. Johnson (1896).

Hunt, THOMAS STERRY, an American chemist and geologist, born at Norwich, Connecticut, 5th September 1826, was assistant to the elder Silliman at Yale College, and from 1847 to 1872 chemist and mineralogist to the Canadian Geological Survey. He was also professor of Chemistry at Laval University (1856-62) and at McGill University (1862-68); from 1872 to 1878 he held the chair of Geology in the Massachusetts Institute of Technology. In 1848-51 he contributed a series of papers on theoretical chemistry to the *American Journal of Science*: in organic chemistry his name is identified with a system essentially his own. His researches into the composition of rocks were of great importance. In 1859 he invented the green ink with which Greenbacks (q.v.) are printed. He was made an officer of the Legion of Honour in 1867, and became an F.R.S. (1859), and LL.D. of Cambridge (1881), and received many other distinctions. At his death, 12th February 1892, he had published over 200 papers and several larger works on chemistry and mineralogy.

Hunt, WILLIAM HENRY, English painter in water-colours, was born in London, March 28, 1790. He was one of the creators of the English school of water-colour painting, Mr Ruskin pronouncing him to be among the greatest colourists of the school. His subjects are very simple—'Peaches and Grapes,' 'Old Pollard,' 'Basket of Plums,' 'Roses,' 'Wild Flowers,' 'Tramps at Home,' 'A Farmhouse Beauty,' 'Fast Asleep,' &c., but they are conceived in a finely poetical spirit, and present the perfection of finish. He died 10th February 1864.

Hunt, WILLIAM HOLMAN, painter, was born in London, 2d April 1827. In his early years he was engaged in business, but in 1845 he was admitted a student of the Royal Academy. In the following year he exhibited his first picture, 'Hark!' a child holding a watch to her ear; this was followed by scenes from Dickens and Scott, and by the more important 'Flight of Madeline and Porphyro,' from Keats' *Exc of St Agnes* (1848). At this period Mr Hunt shared a studio with Dante Gabriel Rossetti, and the pair, along with Millais and a few other earnest young painters, inaugurated the 'Pre-Raphaelite Brotherhood,' of which the members aimed at detailed and uncompromising truth to nature in their rendering of visible things, and at a vivid and unconventional realisation in their treatment of imaginative subjects. In 1850 Mr Hunt contributed to *The Germ*, the short-lived magazine of the brotherhood, two etched subjects illustrating Woolner's poem 'My beautiful Lady,' and at a later period he designed various woodcuts, in particular a remarkable series for the illustrated Tennyson of 1857. The first of the painter's works executed in the Pre-Raphaelite manner was 'Rienzi vowing to avenge the Death of his Brother' (1849), in which the principal figure was painted from Rossetti. It was followed by 'A Converted British Family sheltering a Christian Missionary from the Pursuit of the Druids' (1850); 'Valentine rescuing Sylvia from Proteus,' from the *Two Gentlemen of Verona* (1851); 'The Hiring Shepherd' (1852); and 'Claudio and Isabella,' a tragic and impressive prison-scene from *Measure for Measure* (1853)—works very fresh and original in conception, and carried out with the most careful elaboration; while 'Our English Coasts,' known also as 'The

'Strayed Sheep' (1853), was a remarkable effort in landscape art, realising with exceptional power an effect of vivid sunlight, and combining in a wonderful manner detail and definition with a sense of distance and atmosphere. 'The Light of the World' (1852-54), of which a smaller replica was executed in 1856, ranks as one of the most impressive symbolical works of the century; it is now in the chapel of Keble College, Oxford. 'The Awakened Conscience' aimed to point a moral by means of a scene from modern life. On the completion of the last named picture in the beginning of 1854 Mr Hunt started for Palestine, with the intention of studying eastern life, and realising the incidents of the biblical history with the closest possible accuracy to local colouring and the surroundings amid which they occurred. The result of several prolonged visits to the East appeared in 'The Seapegoat' (1856); 'The Finding of Christ in the Temple' (1860), presented in 1896 to the Birmingham Art Gallery; 'The Shadow of Death' (1874), now in the Corporation Gallery, Manchester; and 'The Triumph of the Innocents' (1875-85), executed in two versions; while the passionate and splendidly coloured 'Isabella and the Pot of Basil' was the result of a visit to Florence in 1867. In 1881 he painted a portrait of Professor Sir Richard Owen; in 1888-89 'The Choristers of Magdalen College, Oxford, singing the May Day Hymn'; and in 1899 the 'Miracle of Sacred Fire at Jerusalem.' In 1886 he contributed to the *Contemporary Review* a series of autobiographical papers; and in the same year over thirty of his works were exhibited in the Fine Arts Society's rooms.

Hunter, JOHN, physiologist and surgeon, was born at Long Calderwood, near East Kilbride, in Lanarkshire, 13th February 1728, and was the youngest of ten children. One of his sisters, Dorothea, was married to Dr James Baillie, professor of Divinity in the university of Glasgow, and was the mother of Matthew and Joanna Baillie (q.v.). His brother William's fame led John to apply for and obtain the situation of assistant in the dissecting-room. He studied surgery under Cheselden in 1749-50 at Chelsea Hospital, and subsequently under Pott. After a year at Oxford he entered St George's Hospital as surgeon's pupil in 1754, afterwards becoming house-surgeon and partner with his brother in the anatomical school. After ten years' hard work of this kind his health gave way, and in 1759 he entered the army as staff-surgeon, and served at Belleisle and in the Peninsula. Peace being proclaimed in 1763, he returned to London and, starting the practice of surgery, devoted much time and money to comparative anatomy. In 1767 he was elected a Fellow of the Royal Society, and in the following year was appointed surgeon to St George's Hospital, an appointment which enabled him to take pupils, of whom one of the earliest was Jenner. His practice at this time was increasing rapidly, but his income never reached £1000 a year until 1774. In 1776 he was appointed surgeon-extraordinary to the king. In 1785 he built his museum, with lecture-rooms, and in the same year he tried his famous operation for the cure of aneurism—that of simply tying the artery at a distance from the tumour, and between it and the heart. In 1786 Hunter was appointed deputy-surgeon-general to the army; in 1787 he received the Copley medal from the Royal Society. He was now universally acknowledged by all the younger surgeons as the head of his profession; but most of his contemporaries looked upon him as little better than an innovator and an enthusiast. He died 16th October 1793, and was buried in the church of St Martin-in-the-Fields, whence, thanks

to Frank Buckland, his remains were translated in March 1839 to Westminster Abbey. Some idea of Hunter's diligence may be gathered from the fact that his museum contained at the time of his death 10,563 specimens and preparations illustrative of human and comparative anatomy, physiology, pathology, and natural history. He died in comparative poverty, and his collection was purchased by government, two years after his death, for £15,000, and was presented to the Royal College of Surgeons.

In addition to the numerous papers contributed to the *Transactions* of the Royal and other learned societies, he published the following independent works: *The Natural History of the Human Teeth* (1771-78); *A Treatise on the Venereal Disease* (1786); *Observations on Certain Parts of the Animal Economy* (1786); and *A Treatise on the Blood, Inflammation, and Gunshot Wounds* (1794). See Palmer's edition of his works (1835), Mather's *Two Great Scotsmen* (1894), and the Life by S. Paget (1897).

Hunter, WILLIAM, anatomist and obstetrician, an elder brother of John Hunter, was born at Long Calderwood, Lanarkshire, 23d May 1718. Originally educated for the church at Glasgow University, he studied medicine for one session (1740-41) at Edinburgh, and then proceeded to London, where he went through a long training in anatomy at St George's Hospital and elsewhere. In 1747 he was admitted a member of the Corporation of Surgeons, ultimately confining his practice to midwifery. In 1762 Hunter was consulted by Queen Charlotte, and two years later was appointed physician-extraordinary to her majesty. Elected a Fellow of the Royal Society, he in 1768 became professor of Anatomy to the Royal Academy. In 1770 he removed to Great Windmill Street, where he had built a house, in connection with which were an amphitheatre for lectures, a dissecting-room, and a museum which contained not only his anatomical preparations, but many objects of natural history and a cabinet of very rare medals and coins. Hunter and his brother John were for many years estranged, owing to a dispute as to the priority of certain discoveries; but the quarrel was made up while William was on his death-bed. He died 30th March 1783. His museum was bequeathed to his brother-in-law, Dr Baillie, and after him, with an endowment of £8000, to Glasgow University (q.v.). His most important work, *An Anatomical Description of the Human Gravid Uterus and its Contents*, did not appear in its complete form till after his death.

Hunter, SIR WILLIAM WILSON, statistician, was born on 15th July 1840, educated at the universities of Glasgow, Paris, and Bonn, and in 1862 entered the civil service of India. His first important office, that of superintendent of public instruction in Orissa (1866-69), gave him the opportunity to write *Annals of Rural Bengal* (1868) and *Comparative Dictionary of the Non-Aryan Languages of India and High Asia* (1868). Then, after filling the responsible offices of secretary to the government of Bengal and the supreme government of India, he was in 1871 appointed director-general of the statistical department of India. The Indian census of 1872 was his first work in his new position. His later books include the compendious *Imperial Gazetteer of India* (9 vols. 1881; 14 vols. 1886-88), *Orissa* (1872), *Life of Lord Mayo* (2d ed. 1876), *Statistical Account of Assam* (1880), *Famine Aspects of Bengal Districts* (1874), *Indian Mussulmans* (1871; 3d ed. 1876), *The Indian Empire* (2d ed. 1886). He received the Star of India in 1878, and in 1887 was knighted. In 1890-96 he edited a series of Lives of 'Rulers of India,' to which he himself contributed *Dalhousie*. *The Old Missionary* (1895) is a touching story of Indian life. He died at Oaken Holt Hall, Oxford, 7th February 1900.

Hunting. See FOXHUNTING, STAG, and the articles on the other animals hunted.

Huntingdon. SELINA, COUNTESS OF, was the second of three daughters and co-heiresses of Washington Shirley, second Earl Ferrers, and was born August 24, 1707. She married the Earl of Huntingdon in 1728, and became a widow in 1746. Adopting the principles of the Calvinistic Methodists, the founder of which sect was the famous George Whitefield, she made that eminent preacher one of her chaplains, and assumed a leadership among his followers, who came to be known as 'The Countess of Huntingdon's Connection.' Her labours at home increased with her years. For the education of ministers she established and maintained a college at Trevecca, in Brecknockshire (removed in 1792 to Cheshunt, Herts.); and built, or became possessed of, numerous chapels in different parts of the country, the principal one being at Bath. She died June 17, 1791. By her will, dated January 11, 1790, she created a trust, bequeathing her chapels, then sixty-four in number, to the care of four persons. Most of them have become, in doctrine and practice, almost identical with the Congregational churches.

Huntingdon. the county town of Huntingdonshire, on the left bank of the Ouse, and the Ermine Street of the Romans, 59 miles N. of London. It became the seat of a royal castle in 917, and was incorporated in 1189. It has breweries, brickworks, carriage-works, and misery gardens. Here Oliver Cromwell was born (1599), and here the poet Cowper lived for a couple of years (1765-67); the chronicler, Henry of Huntingdon (q.v.), was Archdeacon of Huntingdon. With the municipal borough of Godmanchester (pop. 2095), on the opposite bank, it formed a parliamentary borough, returning till 1867 two members, till 1885 one. Pop. (1851) 3882; (1891) 4346.

Huntingdonshire, an inland county of England, 30 miles long, and 23 broad, is bounded on the N. and W. by Northampton, Cambridge, and Bedford shires. Area, 359 sq. m.; almost the whole of which is arable or in pasture. Pop. (1891) 37,568; (1861) 64,250; (1891) 57,761. Huntingdonshire has no hill-ranges of any importance, and is watered chiefly by the Nene, which forms its northern boundary, and the Ouse; in the fen-district in the north-eastern part of the county, forming part of the Bedford Level (q.v.), there were formerly some large lakes or meres, notably Whittlesea, Ramsey, and Ugg; but these have been drained and reclaimed for cultivation. The soil consists principally of clay, with, in places, sand, gravel, and peat earth, the latter being almost wholly confined to the fen-district. Huntingdonshire comprises four hundreds and the municipal boroughs of Huntingdon, Godmanchester, and St Ives, with part of the city of Peterborough, the greater portion of which is however in Northamptonshire. It contains 103 parishes, is almost entirely in the diocese of Ely and the South-eastern Circuit, and returns two members to parliament. A peculiarity in its civil government is that it is included under the same shrievalty with Cambridgeshire, the sheriff being annually chosen in rotation from the county of Cambridge, the Isle of Ely, and this county. Of its earlier inhabitants Huntingdonshire has numerous traces; two Roman roads traverse it; at Alwalton, Earith, and Chesterton are remains of camps, the construction of which is also ascribed to the Romans; and in many places Roman remains, as pottery, coins, &c., have been found. Among places of interest in the county those most worthy of mention are the ruins of Ramsey Abbey and Buckden Palace, the latter being formerly the residence of the bishops of Lincoln; Hinchinbrook

House, anciently the seat of the Cromwell family; Kimbolton Castle, the seat of the Duke of Manchester, where Queen Catharine resided for some time after her divorce from Henry VIII.; Horeham Hall, the residence of the Princess Elizabeth during the reign of her sister Mary; Denton, the birth-place of Cotton the antiquary; Little Gidding, the seat of Nicholas Ferrar's community; and Brampton, where lived for some years Samuel Pepys.

Huntly, a town of Scotland, 41 miles NW. of Aberdeen. In the vicinity is the ruin of Huntly Castle, the seat of the earls and marquises of Huntly (see GORDON). Huntly is the birthplace of Dr George Macdonald. Pop. 3760.

Huntsville, capital of Madison county, Alabama, in the valley of the Tennessee, 10 miles N. of the river, and 212 miles ESE. of Memphis by rail. It has an ice-factory, a foundry, and manufactures of cotton, cotton-seed oil, and flour. Pop. (1880) 4977; (1890) 7995.

Hunyady Janos. John Corvinus Hunyady, governor of Hungary, one of the greatest war-captains of his age, was born towards the close of the 14th century. His origin is wrapped in mystery, the current legend being that he was a son of the Emperor Sigismund by a Wallachian lady. His life may be succinctly described as one unbroken crusade against the Turks. During the period 1437-56 he was the shield of Hungary, not only against external foes, but against the lawlessness of the nobles at home. The principal moments in his celebrated contest with the foes of Christendom are his expulsion of them from Transylvania in 1442; his brilliant campaign south of the Danube in 1443; his defeat in the bloody battle of Varna, 1444; and that at Kossovo in 1448; but his most glorious achievement was the storming of Belgrade (1456). Shortly afterwards Hunyady died of dysentery. During the minority of Ladislaus V. the great captain acted as governor of the kingdom (1445-53). Hunyady left two sons, Ladislaus and Matthias—the former of whom was beheaded at Buda on a charge of conspiracy; the latter succeeded to the crown of Hungary (q.v.).

Hunza-Nagar, the valley (containing the forts of Hunza and Nagar) of a river running into the Gilgit, at the extreme NW. corner of Cashmere. Together with Kanjut, the upper part of the same valley, it became British in 1891.

Huon Gulf. See NEW GUINEA.

Huon of Bordeaux, one of the Charlemagne cycle of romances. In its present form it is a prose version, dating from 1454, of a poem current about the end of the 12th century, and sometimes ascribed, without grounds, to the trouvère Huon de Ville-neuve. In the story, Huon, Duke of Guienne, one of the paladins of Charlemagne, in self-defence kills Charlot, son of Charlemagne, and is in consequence condemned to die, but his life is granted on the hard condition that he brings back from Bagdad some of the Saracen emir's teeth and beard after having kissed his daughter before his face. The dwarf Oleron gives him a magical cup and horn, one blast of which in the hour of peril brings him and 100,000 warriors to Huon's aid. Moreover, the princess Esclarmonde, like Medea, lightens his labours by falling in love with him, so that at last he is completely successful, and returns with her as his wife to clear himself before Charlemagne. The prose romance was printed at Paris in 1516; and Lord Berners' English translation, by Wynkyn de Worde, in 1534 (ed. by S. L. Lee for E. Eng. Text Soc., 1882-87; simplified by Steele, 1896).

Hū-pei, one of the central provinces of China, watered by the Yangtse. See CHINA.

Hurd, RICHARD, English prelate and writer, named the 'Beauty of Holiness' on account of his comeliness and piety, was born at Congreve, in Staffordshire, January 13, 1720, and studied at Emmanuel College, Cambridge, of which he became a Fellow in 1742. In 1749 appeared his first notable production, *Commentary on Horace's Ars Poetica*. In connection with this work Gibbon wrote of the author, 'I know few writers more deserving of the great but prostituted name of critic; but, like many critics, he is better qualified to instruct than to execute.' In 1750, on the recommendation of Warburton, of whom he was a life-long friend and admirer, and whose *Works* he edited in 1788, he was appointed one of the Whitehall preachers. He afterwards (1774) became Bishop of Lichfield and Coventry, but exchanged this see for Worcester in 1781; in 1783 he declined the archbishopric of Canterbury. He died May 28, 1808. His principal works are *Dissertations on Poetry, &c.* (1755-57); *Dialogues on Sincerity, Retirement, the Golden Age of Elizabeth, and the Constitution of the English Government* (1759), his most popular book; *Letters on Chivalry and Romance* (1762); *Dialogues on the Uses of Foreign Travel* (1764); and *An Introduction to the Study of the Prophecies concerning the Christian Church* (1772). See Hurd's *Works* (8 vols. 1811) and *Memoirs* by Kilvert (1860).

Hurdwār. See HARDWAR.

Hurdy-gurdy, a very old musical instrument of the stringed kind, something between a guitar and a lute in appearance. It has four or six catgut or wire strings attached to screw-pegs in the head; two of the strings stretch over the sounding-board to the tailpiece, and are sounded by a wooden wheel (under the cover *a* in the fig.) charged with rosin, which is turned by means of a handle with the player's right hand. The

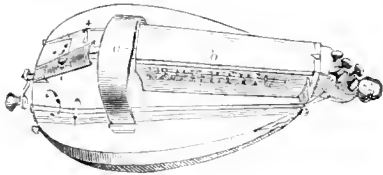

Hurdy-gurdy.

strings are 'stopped' by an ingenious arrangement of keys, *b*, manipulated with the left hand. The remaining strings are stretched out of reach of the keys, and are tuned as drones. The instrument has a range of two octaves from the tenor G upwards. The rustic simplicity of its music made it at one time a great favourite among the peasantry of a great part of Europe (see Engel's *Musical Instruments*). The name hurdy-gurdy is also sometimes applied to the mechanical pianos familiar on the streets. The word was probably coined to express contempt of the instrument.

Hurlingham, at Fulham (q.v.) in Middlesex, on the Thames, below the bridge, the headquarters of Pigeon-shooting (q.v.) and polo.

Huron, the second in area of the five great lakes on the frontier between the United States and Canada, is connected at the north-west by St. Mary's River with Lake Superior, and through the strait of Mackinaw with Lake Michigan. On the south it has an outlet by way of the St. Clair River. It is bounded on the W. and SW. by Michigan, and elsewhere by Ontario. The lake is divided into two unequal parts by the Cabot's Head peninsula and Grand Manitoulin Island, the parts to the north being called North Channel and Georgian

Bay. Its extreme length is 263 miles; its greatest breadth, exclusive of Georgian Bay, 105 miles; average breadth, 70 miles. The area of the entire lake is 23,800 sq. m.; it is larger than Lake Michigan, although its basin is smaller. According to the perfected levels of the United States Lake Survey, its mean elevation is 581 $\frac{1}{2}$ feet above sea-level; it is 20 $\frac{1}{2}$ feet below Lake Superior, and 8 $\frac{1}{2}$ above Lake Erie. Huron has a mean depth of about 250, and a maximum depth of 750 feet. There is an average difference between high and low water (due to winds and rain) of 1 $\frac{1}{2}$ foot. Huron, like the other lakes, is subject to violent storms. It contains about three thousand islands, nearly all Canadian; some of them are of considerable size. The waters are very clear and pure, and abound in fish. There are numerous good harbours and roadsteads, most of them on the Canadian side; at Sand Beach, Michigan, there is a harbour of refuge. See Crossman's *Chart of the Great Lakes* (Milwaukee, 1888).

Huronian, a subdivision of the Archaean rocks of Canada. See ARCHAIC SYSTEM.

Hurons, a once powerful tribe of American Indians, belonging to the Huron-Iroquois family. In the early part of the 17th century the Hurons numbered about 30,000 persons, living in twenty-five villages within a small territory near Georgian Bay. By the end of the century the tribe had been nearly destroyed by the Iroquois, famine, and disease; and in 1693 the few survivors were removed by the French to Petite Lorette, near Quebec. Here two or three hundred descendants still live; but very few are of pure blood, and all are Catholics, and have abandoned their own language for French.

Hurricane. See STORMS, and WIND.

Hursley, a village of Hampshire, 5 miles SW. of Winchester. John Keble, author of the *Christian Year*, was vicar here from 1835 till his death in 1866. In 1848, with the profits of that celebrated work, he restored the church, which is rich in modern stained glass. Keble himself lies buried in the churchyard, and in the chancel is the grave of Richard Cromwell.

Hurstmonceaux, a village of Sussex, 5 miles N. of Pevensey, with the extensive ivy-covered ruins of a fine castle, built of brick under Henry VI. by Sir Roger de Fienes, one of the heroes of Agincourt. It passed in 1727 into the hands of the Hares or Hare-Naylors. The then head of the house, Bishop Hare, took good care of the estate, but its resources were shamefully squandered by the two succeeding heirs, and about the close of the century the castle was unroofed and its valuable contents sold off at a six weeks' sale. A modern mansion was built near its ruins. The famous Broad Church leader, Archdeacon Hare (q.v.), was rector of the parish from 1832 till 1855, and lies buried in the churchyard. The church is Early English, with Perpendicular windows, and contains, among other ancient monuments, the fine canopied altar-tomb of the second Lord Daere.

Hurstpierpoint, a market-town of Sussex, 8 miles N. by W. of Brighton. Here is St. John's College (1849), a middle-class school in connection with Lancing (q.v.). Pop. of parish, 2736.

Husband and Wife. The marriage-contract is for the joint lives of the parties, and comes to an end with the death of either; they cannot themselves put an end to it or escape from its obligations, except by means of a legal Divorce (q.v.) or Separation (q.v.). It is a not uncommon delusion among working-people that if a husband or wife runs away or disappears the deserted

spouse may lawfully marry again; but this is not the case. If husband or wife disappears, and is not heard of for seven years, the party deserted may marry again without incurring the risk of a conviction for bigamy; but even in this case the second marriage is a nullity if the first husband or wife is alive at the time when it is solemnised. During its continuance the contract has important effects on the rights and mutual relations of the parties. The husband is, in law, the head of the house; he has a right to choose the family domicile, and to require his wife to cohabit with him there. He may sue and be sued, enter into contracts, and dispose of his property as freely as a single man; the modern English law permits him to bequeath his property without making any provision for his wife, and to bar her claim to dower in disposing of his landed estate. He is bound to maintain his wife and children; if, being able to maintain them, he neglects to do so, his goods may be seized and sold by the parish authorities, or he may be imprisoned for one month as a disorderly person. If he deserts his wife and family, leaving them to become a charge on the parish, he may be treated as a rogue and vagabond, and imprisoned for three months. If his wife leaves him without just cause he is not bound to support her, and he may compel her to return by bringing an action for the restitution of conjugal rights. But if there is just cause for separation—if, for example, the husband is guilty of what the law deems cruelty—as keeping a mistress in the house, or starving and beating his wife—the wife is not bound to return, and the husband will be liable for the price of necessaries ordered by her on his credit. When the parties are living together, the question whether the wife has authority to pledge her husband's credit must be decided on consideration of all the facts of the case. No authority is implied from the mere fact of marriage, and tradesmen are not safe in relying on the wife's assertion in such cases; but a woman who keeps her husband's house may be taken to have authority to order food and clothing suitable to their rank in life, unless the husband has taken steps to protect himself from liability, as, for example, by giving notice to the tradesman not to trust his wife. Much misconception prevails in regard to the extent of a wife's authority; and there is a class of small traders, called tallymen, who take advantage of the popular ignorance. They persuade working-men's wives to purchase dresses or other goods, to be paid for by instalments; on default in payment, the husband is often made to pay heavily for his wife's improvidence, though it may be that in law he is not liable at all. In such a case it is sometimes best for the husband to allow himself to be taken into a county court, where the judge will see that the tallyman gets no more than his due. A policy of insurance, effected by a husband on his own life for the benefit of his wife or children, is protected against his creditors.

A married woman is called in law French *feur coverté*; she is protected by her husband and under his control, and the two are, for many purposes, one person in law. If she commits a crime in his company or under his coercion the crime is his, not hers; he is punished and she escapes; but this rule does not apply to treason, murder, and other heinous offences. Formerly she could sue only by her next friend, and if she was sued, her husband was joined; but modern rules permit her to sue and defend alone. At common law the wife's personal property vested in the husband; he took the profits of her land during the marriage; and if an heir was born of the marriage the husband became 'tenant by the courtesy of England,' and held the land for his own life if he survived his

wife. He assumed her liabilities also, and might be sued for her ante-nuptial debts. But at an early period courts of equity decided that, where property was given for the separate use of a married woman, she herself should have the use and disposition of it; if such property came into the husband's hands he held it as trustee for her. This doctrine of separate use has been greatly extended by the Married Women's Property Acts of 1870, 1874, and 1882. These acts do not apply in their integrity to women married before they came into operation; it is therefore necessary in ascertaining the rights of a wife to know when she was married. Under the Act of 1882 a wife holds her realty and personality as her own separate property; she may enter into contracts relating to it, and dispose of it as freely as a *jure sole*. Her property is liable for her separate debts, and execution may issue against it, though not against her person. Her husband is not liable for her ante-nuptial debts, except to the value of any property which comes to him through her. She may insure her own or her husband's life for her separate use. All earnings of the wife are protected by the Married Women's Property Acts; and under an earlier act a woman separated from her husband may obtain a magistrate's order protecting her earnings. A woman who has property may be made liable under the poor-law for the maintenance of her husband and children.

Marriage is a 'valuable consideration,' and a settlement of property made in pursuance of the contract stands good even against creditors. Provisions for the benefit of children are 'within the scope of the marriage bargain.' A post-nuptial settlement, unless made in fulfilment of a previous bargain, is not made in consideration of marriage; it may be upset by creditors like any other voluntary transfer of property.

The old rule that husband and wife are one person has been so far set aside by legislation that some of the consequences deduced from it are now doubtful in point of law. Formerly, if property were given in equal shares to husband and wife and a third person, the husband and wife took half and the third person the other half; and it has been decided that this rule applies even in a case of a gift or will made since 1882. Again, it used to be held that a woman could not be convicted of stealing her husband's goods; but sections 12 and 16 of the Act of 1882 enable married persons to prosecute one another. Except in cases within the act, and cases of personal injury inflicted by one spouse on the other, husband and wife cannot give evidence in criminal proceedings against one another; thus, on a trial for bigamy, the first wife cannot be called to prove her own marriage. In civil actions the spouses are competent witnesses for and against one another.

A husband surviving his wife is entitled to her personal property not disposed of by her, and has a paramount claim to administer her estate. A wife surviving her husband is entitled to one-third of his personality not disposed of by him, and she has a claim to administer; she has also a claim to dower—i.e. a life-estate in one-third of his land, unless the claim to dower has been barred.

In the United States the law of husband and wife is based upon the common law of England as above explained. The legislation of the different states, however, has diverted the common law rules with somewhat varying effect in the direction of the recent English statutes, and considerably in advance of them upon the same lines. A long series of statutes, beginning at an earlier period than in England about 1844—has now swept away the disabilities laid upon married women by the common law. Wives are now generally able to hold

property, real and personal, in their own right, to enter into contracts, and to sue in their own names. They are on substantially an equal footing with unmarried women; and it is not uncommon for married women to carry on business in their own names and with full power to enforce contracts. The old rule that husband and wife are one person in law is now practically obsolete. A wife may contract with her husband and may sue him upon the contract, in some states directly, in others through the intervention of a guardian or trustee. The independent position conceded by the law to married women in the United States is a chief cause of the recent increase and frequency of divorce in that country.

The law of Scotland has specialties of its own. The husband is the legal curator of his wife; and if at the time of the marriage she have another curator, the office of this last expires. Thus actions brought against a wife must be brought also against the husband for his interest, and the husband must concur in actions raised by the wife. The husband further in his capacity of curator signs as co-consentor to the wife's deeds. The husband is liable for the ante-nuptial debts of his wife; but under the Married Women's Property Act, 1877, this liability is limited to the amount by which the husband receives profit from the marriage. The wife has power to bind her husband in so far as she acts with his authority and as his agent. With regard to furnishings to the family, the wife is presumed by law to be the manager of the household, *proposita negotiis domesticis*, and so to be authorised to bind the husband. This presumption can only be removed by inhibition or by private notice from the husband to tradesmen. The *ius mariti*, or husband's right, had the effect of transferring to the husband upon marriage all the personal property of the wife belonging to her at the time of the marriage, or acquired by her during its subsistence. It also gave the husband the rents and yearly income of her heritable property; but it did not extend over the wife's paraphernalia. Besides the *ius mariti*, the husband possessed the right of administration of his wife's heritable property. In virtue of this right, the husband's consent is necessary to all acts by which the wife deals with her heritage. Both of these rights may be renounced by the husband or excluded by special contracts and settlements; and with regard to marriages that come under the Married Women's Property Acts these rights are to a great extent extinguished.

The effect of the Married Women's Property Act, 1882, is to abolish the *ius mariti* altogether with regard to marriages contracted after its date; to vest in the wife as her own separate estate all the movable property acquired by her at any time. The statute practically does away with the husband's right of administering the income of the wife's estate. The earnings of married women and those of women living separate from their husbands are protected by prior statutes against the husband and his creditors. On the death of a wife the surviving husband has a life interest, called courtesy, in her heritable estate; and has the same interest in her movable estate as a widow has in the movable estate of her deceased husband—i.e. a share amounting to one-half if there are no children, and one-third if there are. This share, when it falls to a widow out of the estate of her deceased husband, is hers by virtue of the *ius relicte* or relic's right. The widow has further, where she has no conventional provision, a right to the terec, which is a life interest of a third of the husband's heritable property.

See works by Lush (1881), Macqueen (1885), Schonler (Boston, 1882), Thicknesse (1884), and Crawley (1892).

Husch, or HUSI, a town of Moldavia, near the Pruth, 38 miles SSE. from Jassy, cultivates tobacco and the vine. It was founded by fugitive Hussites in the 15th century. Here was signed in 1711 the treaty between the Russians and Turks by which Peter the Great rescued his army, surrounded by the foe. Pop. 18,500.

Huskisson, WILLIAM, statesman and financier, was born at Birtsmorton Court, in Worcestershire, 11th March 1770, and in 1783 was sent to Paris to study medicine. He was present at the storming of the Bastille, and as a member of the Club of 1789 attracted attention by a speech on the assignats. Returning to England, he was appointed in 1795 under-secretary in the Colonial Department. Next year he entered parliament for Morpeth as a supporter of Pitt. Being returned for Liskeard in 1804, he was appointed secretary of the Treasury; and he held the same office under the Duke of Portland (1807-9). In 1814 he became chief Commissioner of the Woods and Forests; in 1823 President of the Board of Trade, and treasurer of the navy; and in 1827 Secretary of State for the Colonies. But he resigned office finally in the following year. Through his exertions the old restrictions on the trade of the colonies with foreign countries were removed. He also obtained the removal or reduction of many import duties, considerable relaxation of the navigation laws, and is allowed to have been an active pioneer of free trade. He received fatal injuries at the opening of the Liverpool and Manchester Railway, 15th September 1830, and died the same evening. A collection of his speeches, with a Life prefixed, was published in 3 vols. in 1831.

Huss, or more properly HUS, JOHN, Bohemian reformer and martyr, was born in (probably) 1369, the son of a Bohemian peasant, at Husinec (of which Hus is a contraction), NW. of Budweis. Two years after taking (1396) his master's degree at the university of Prague he began to lecture there on theological subjects. He had at this time already come under the influence of Wyclif's writings, in all probability through Anne of Bohemia's retinue, and he is believed to have made them the basis of his teaching. In 1402 he was appointed rector of the university, and began to preach at the Bethlehem chapel in the city of Prague. It was not, however, until the year 1408 that he came into conflict with the Roman Catholic Church. In that year certain of his pulpit utterances against clerical abuses were laid hold upon by the clergy of the diocese and city of Prague, and made the ground of a formal complaint against him to the archbishop, Shynko. In consequence of this Huss was forbidden to exercise priestly functions within the diocese. Early in the following year the element of political feeling was infused into the quarrel, all the strong interests of the awakening national consciousness ranging themselves in support of the reformer, who by his preaching had completely won the hearts of the common people. Although Huss was again elected rector of the university in October 1409, the archbishop commissioned an inquisitor to investigate the charges of heretical teaching which had been alleged against him. And it was undoubtedly in connection with this proceeding that in December the pope (Alexander V.) promulgated a bull in condemnation of Wyclif's teaching, and ordered all his writings to be publicly burned, and at the same time forbade preaching in any except collegiate, parish, and monastery churches. This, however, not being sufficient to prevent Huss from continuing his preaching, he was in the following July excommunicated by the Archbishop of Prague. Popular riots followed in the city, and Huss, backed by the

people, still maintained his position; nor did he yield one jot even after the entire city was laid under a papal interdict in 1411. But by the last month of the following year matters had greatly changed, in consequence of Huss having spoken out yet more boldly against the church; hence some of his more influential supporters, including the university, had fallen away from him, so that he was constrained to yield to the desire of the king of Bohemia, Wenceslaus, that he should absent himself from Prague. He found refuge at the castles of certain of his supporters, for nearly the whole body of the nobles were with him. This enforced leisure he employed chiefly in the composition of his principal work, *De Ecclesia*. This book, together with many of Huss's minor writings, contains numerous passages taken almost verbatim from Wyclif's works; and the authorities of the Roman Catholic Church must have looked upon Huss as the expounder and propagator of Wyclif's views. About this time a general council was summoned to meet at Constance, and Huss was called upon to present himself before it, in order to have his case adjudicated upon. Provided with a 'safe conduct' from the Emperor Sigismund, he arrived at Constance on 3d November 1414. Three weeks later, in violation of his safe-conduct, he was seized and thrown into prison. No precise charge had been lodged against him; but he had resumed preaching after his arrival in Constance. An ill-angry for Huss was the condemnation of Wyclif's writings by the council in May 1415. His own trial began on 5th June following; but he was not permitted to speak freely in his own defence, nor allowed to have a defender to speak in his behalf. Called upon to recant unconditionally, to make full submission to the council, and to pledge himself not to preach or teach the doctrines that were put in accusation against him, Huss categorically refused, and was forthwith led to the stake, and burned to ashes, on 6th July.

HUSSITES.—The news of the imprisonment and death of John Huss roused popular feeling in Bohemia to the highest pitch of wrath and indignation. Whilst the masses gave way to rioting and murdered Roman Catholic ecclesiastics, 452 nobles, in a diet which had been hastily summoned at Prague in September 1415, solemnly attested their confidence in Huss, and their admiration of his personal character, and three days later formed themselves into a league for the maintenance of liberty of preaching in Bohemia, and for upholding their belief in the Word of God as the ultimate lawgiver of the church. For this they were excommunicated by the council. Both parties now prepared for war. Yet it soon became apparent that the Hussites were not all of one mind; for, as in all great popular movements of this kind, there was an extreme party who were desirous of carrying things to the greatest lengths. The more moderate section formulated their demands in four articles, preaching of the gospel in the Bohemian language, the right of the laity to receive the communion in both kinds, reform of clerical abuses, and the prohibition of the clergy to hold secular property and exercise secular jurisdiction; these were called Praguerers, but more frequently Calixtines (*calix*—a chalice) or Utraquists (from their claiming communion *sub utraque specie*). The extreme party, headed by Ziska (q.v.), and called Taborites, from their headquarters being at Mount Tabor, some 24 miles N.E. of Pisek, went beyond the Utraquists in their condemnation of purgatory, the worship of saints, of images, and of relics, and the practice of penance, and in their assertion of the right of the laity, even of women, to preach, and that in any building they pleased. At this period too King Wenceslaus died, and the throne of

Bohemia was claimed by his brother, the Emperor Sigismund. Nevertheless, both parties united in offering a stubborn resistance to the emperor, and his forces were defeated at Ziskaberg in 1420, at Deutsch-Brod in 1422, at Aussig in 1426, and at Taus in 1431. Under the two brothers Procopius the Hussites invaded Silesia, Saxony, and Franconia; they were said to have taken and destroyed more than 100 towns and 1500 villages; according to a doubtful legend, Namburg was saved by the intercession of the school children. After the battle of Taus negotiations were begun, which ended, two years later, in the Calixtines securing their ends by the 'Compactata of Prague,' which was signed by the delegate of the Council of Basel on 30th November. This pacification the Taborites refused to accept, and in the contest that then ensued between them and the Calixtines, they were worsted at Lipan near Kolin and at Irib near Bohmisch-Brod in 1434, and from that time rapidly disappear from history. Two years later the Emperor Sigismund, after ratifying the 'Compactata' with his signature, was accepted by the Bohemians as their king. The Utraquists finally became merged in the Moravian Brethren (q.v.).

See *Documenta Johannis Hus citam, doctrinam, causam illustrantia* (ed. by Palacky, 1839), and monographs by Becker (1858), Krummel (1863), Berger (1872), Wratislaw (in English, 1882), and Loserth (1884; Eng. trans. 1884); Doms, *Huss et la Guerre des Hussites* (1878); Palacky, *Urkundliche Beiträge zur Geschichte des Hussitenkriegs* (1872-73); Krummel, *Geschichte der Böhmischem Reformation* (1866); Bezold, *Sagen und die Reichskrieg gegen die Hussiten* (1872-77), and *Zur Geschichte des Hussitenlehrens* (1874); Wratislaw, *John Hus* (1882); Leger, *History of Austro-Hungary* (Eng. trans. 1890); Lechler, *Johannes Huss, ein Lebensbild* (1890); the articles BOHEMIA ('Literature'), ZISKA, PODIEBRAD, CONSTANCE, WYCLIF, &c.

Hussar, a light-cavalry trooper, wearing in full dress a tunic and Busby, (q.v.), and armed with sabre and carbine. The 10th and 18th Light Dragoons were changed in 1806-7 to Hussars, the earliest in the British army (see CAVALRY). The name is not a Hungarian *huszár*, indicating that they were raised one out of every twenty inhabitants; but pure Slavonic for 'Goosherd,' a name given to bodies of wild, raiding horsemen, organised and taken into pay by Matthias Corvinus.

Hussein. See SHITES.

Husum, an old town in the Prussian province of Sleswick-Holstein, 23 miles W. of Sleswick by rail and 2½ from the North Sea. Pop. 6267.

Hutcheson, FRANCIS, a distinguished philosopher of the 18th century, was the son of a Presbyterian minister in the north of Ireland, where he was born in 1694. He studied for the church at the university of Glasgow, but shortly after the completion of his theological course he was induced to open a private academy in the city of Dublin, which proved highly successful. In 1720 he published his *Inquiry into the Original of our Ideas of Beauty and Virtue*, &c., which was the means of introducing him to the notice of many influential personages, such as Lord Granville, then lord lieutenant of Ireland, Archbishop King, Primate Boulter, and others. This work was followed in 1728 by his *Essay on the Nature and Conduct of the Passions*; and in the year after he was appointed professor of Moral Philosophy in the university of Glasgow. Here he died in 1747. In his lifetime he published various minor books, including a small treatise on *Logic*; but his largest work, *A System of Moral Philosophy*, was published at Glasgow in 1755 by his son, Francis Hutcheson, M.D., with a Life by Dr Leechman. As a metaphysician Hutcheson may in some respects be considered a pioneer of the so-called 'Scotch school'

and of the common-sense philosophy, although he is largely influenced by Locke. From the delivery of Hutcheson's lectures, according to Dugald Stewart, may be dated the metaphysical philosophy of Scotland. But it is as a moral philosopher, rather than as a metaphysician, that Hutcheson was conspicuous. His system is to a large extent that of Shaftesbury, but it is more complete, coherent, and clearly illustrated. Hutcheson is a strong opponent of the doctrine that benevolence has a selfish origin; he is practically a utilitarian; and the faculty by which moral distinctions are recognised Hutcheson (after Shaftesbury) terms a *moral sense*. See ETHICS; Fowler, *Shaftesbury and Hutcheson* (1882); and W. R. Scott, *Francis Hutcheson* (1900).

Hutcheson, ANNE, a religious enthusiast, was the daughter of a Lincolnshire clergyman called Marbury. Born in 1590, she married a Mr Hutcheson, and in 1634 they emigrated from Lincolnshire, England, to Boston, Massachusetts. She held various theological heresies; amongst others, that the person of the Holy Ghost dwells in justified persons. She held meetings, lectured, and denounced the Massachusetts clergy as being with few exceptions 'under the covenant of works, not of grace.' Her followers were charged with Antinomianism (q.v.). Great controversies arose, and a synod was called, in which her teachings were condemned; and being tried for heresy and sedition, she was banished from the colony. She and her friends acquired territory from the Narragansett Indians of Rhode Island, where they set up a community on the highly commendable principle that no one was to be 'accounted a delinquent for doctrine.' After the death of her husband (who shared her opinions) she removed to a new settlement in what is now New York state, where, in 1643, she and her whole family of fifteen persons were taken prisoners by the Indians, and all but one daughter barbarously murdered.

Hutcheson, JOHN, an English theological writer, born in 1674 at Spennithorne, in Yorkshire. He was for some time steward of the household of the Duke of Somerset, and left his service to devote himself to his religious studies, the duke procuring for him a sinecure appointment of £200 a year from government. In 1724 he published the first part of a work called *Moses' Principles*, in which he defended what he regarded as the Mosaic cosmogony, and assailed Newton's theory of gravitation. He continued to publish a succession of works till his death, which took place on 28th August 1737. His religious system is best exhibited in his *Thoughts concerning Religion*. The leading principle of it is that the Holy Scriptures contain the elements not only of true religion, but of all rational philosophy, which, however, was to be derived only from the original Hebrew; and it, for that purpose, was subjected to strange critical or rather fanciful processes. His followers were called HUTCHINSONIANS, and among them were persons of considerable learning and celebrity. Ministers of some of the Scottish Presbyterian churches are yet required explicitly to renounce the errors of the Hutchesonians.

Hutcheson, COLONEL JOHN, the type of the Puritan gentleman, was the son of Sir Thomas Hutcheson, and was born at Nottingham in September 1615. He studied at Cambridge, and next for a short time at Lincoln's Inn, and married in 1638 Lucy, daughter of Sir Allen Apsley. He now retired to Owlthorpe, and here his meditations on the troubled theology and politics of the time led him at last to side with the parliament rather than the king. He became governor of Nottingham, and successfully held the town against enemies without and intrigue and calumny from

within till the close of the struggle. About the beginning of the year 1646 he was sent up by Nottingham to fill his father's place in the parliament, and later sat as one of the commissioners in the High Court of Justice for the king's trial, and signed the warrant for his execution. He sat in the first council of state, but gradually became alarmed at the ambitious schemes of Cromwell, and ceased to take an active part in politics. At the Restoration, along with other regicides, he was included in the Act of Amnesty, but later was imprisoned for about a year in the Tower and at Sandown Castle in Kent on a groundless suspicion of treasonable conspiracy, and died 11th September 1664. The *Memoirs*, written by his widowed wife for her children, was first published in 1806, and revealed to the world a delightful picture of a grave and courteous gentleman, beautiful and accomplished; tender to his family and the poor; fearless, frank, and honest in temper; intense in devotion, yet entirely free from austerity and fanaticism. The unsought beauty of the style, and the absolute sincerity and truthfulness of the narrative, give the book an almost unique place among English biographies, and the tender devotedness of loving memory with which throughout it is informed has still power to touch the modern reader with a thrill of sympathetic emotion. An excellent edition, by C. H. Firth, was published in 1885.

Hutten, PHILIP VON, a German adventurer, and a cousin of Ulrich von Hutten, was born at Birkenfeld about the end of the 15th century, and was educated at the court of Henry of Nassau. In 1528 the Emperor Charles V. made a grant of the province of Venezuela to the Welsers, a firm of rich Augsburg merchants; and Hutten sailed with one of the companies they sent out. He accompanied the viceroy, Georg Hoheent, in a long journey (1536-38), in which they reached the headwaters of the Rio Japura, near the equator. In 1541 he set out in search of the Golden City. After several years of wandering, harassed by the natives and weakened by hunger and fever, he and his followers came on a large city, the capital of the Omaguas, in the country north of the Amazons; and attacking this place, they were routed by the Indians, and Hutten himself severely wounded. He led those of his followers who survived back to Coro in 1546, where Juan de Carvajal had in the meantime usurped the office of viceroy; and by him Hutten and his lieutenant, Bartel Welsler, were seized and beheaded. Eight years later the Welsers' grant was taken from them, and the rule of the Germans in Venezuela came to an end. Hutten left a narrative of his journeyings, which was published under the title *Zeitunge uns Indien* (1765). See also Von Langeegg, *El Dorado* (Leip. 1888).

Hutten, ULRICH VON, poet, humanist, and reformer, was born on 21st April 1488, of an old Franconian family whose seat was at Stechelberg, near Fulda. Being piny and small of stature, and of weak health, he was destined, although the eldest son, for the tonsure, and was sent in 1499 to the Benedictine monastery of Fulda. But his temperament—proud, high-spirited, impetuous, impatient of contradiction and of restraint—did not fit him for leading the religious life, and in 1504 or 1505 he fled away from the monastery. Consumed with a devouring hunger for knowledge, especially for the new Humanistic learning, Hutten visited the chief universities of northern Germany, and finally passed by way of Vienna into Italy (1512). During these years he was often utterly destitute, and generally ill, sustained only by his love for the New Learning and his indomitable spirit. His

first works—Latin poems—were printed in 1509; and in the same year he wrote the first of his many bitter satires. From this time onwards his pen never rested; when not employed in behalf of the great cause it was busy in some private feud or quarrel. In Italy Hutten remained nearly two years. On reaching home he was received with distinction at the court of Albert, Archbishop and Elector of Mainz. There he first became acquainted with Erasmus, the leader of the Humanistic movement. In the spring of 1515 all the fiery combativeness of Hutten's nature was roused by the murder of his cousin Hans, who had been wantonly slain by Ulrich, Duke of Wurtemberg. The young poet launched denunciation after denunciation at the guilty duke, and called upon the emperor to punish the offender; and, himself girding the sword upon his thigh, he marched into Wurtemberg along with the army of vengeance his family had raised. His friends then sent him back to Italy to study law. At Rome and at Bologna he spent nearly two years, and came home to enter the service of the Archbishop of Mainz. It was at this time that he wrote his most important work, his share of the *Epistolæ Obscurorum Virorum* (q.v.).

Having been formally crowned poet-laureate of Germany by the Emperor Maximilian at Augsburg in 1517, Hutten began the real work of his life, his deliberate assault upon papal aggressiveness, in an ironical dedication to Leo X. of a new edition of Laurentius Valla's exposure of the fictitious Donation of Constantine. When he first heard of Luther's revolt, Hutten looked upon it as a mere monks' quarrel. In 1519 he took part, along with his subsequent friend and patron, Franz von Sickingen, in the campaign of the Swabian League against his old enemy, Duke Ulrich of Wurtemberg. But this concluded, he returned to the attack upon the papal power. The ideal that possessed his soul was to create a national Germany, delivered from the hateful interference, extortion, and spiritual tyranny of supercilious priests from beyond the Alps. But he also aimed at an intellectual reform of the so-called learned classes, through the spread of the New Learning, and at the cultivation of refinement in the habits and manners of his countrymen. At length he came to understand the real significance of Luther's action, and, at once joining hands with him, he espoused the reformer's part with his customary impetuosity and vehemence. Henceforward he was more closely identified with the Reformation than with the Humanistic movement. A set of dialogues which he published in 1520 contained *Vulsiensis*, his formal manifesto against Rome. This at last stung the pope to take retaliatory measures, and he caused the archbishop to dismiss Hutten from his service. Hutten found shelter in Sickingen's strong castle of Ebernburg in the Palatinate, whence during the next two years he discharged a perfect shower of invectives, denunciations, and satires at the heads of the Romanists, and wrote appeal after appeal to the German emperor, the princes and nobles, bishops, scholars, and people, urging them to shake off the tyrannous domination of the enemies of their country. And in order to get at the common people he began to write in the vernacular, his earliest work in German being *Aufwecker der teutschen Nation* (1520), a poem in which Hutten's satiric powers reach their highest pitch. Sickingen's castle having become unsafe, Hutten fled in 1522 to Basel, where he was greeted with marked coldness by Erasmus. This estrangement shortly afterwards gave rise to a bitter epistolary quarrel. At Basel Hutten was again attacked by the odious disease from which he had suffered since boyhood; and, after seeking

a safe retreat at Mühlhansen and at Zurich, was befriended by Zwingli, who found him an asylum on the little island of Ufnau in the Lake of Zurich. There Hutten ended his stormy life in 1523.

His writings fall into three divisions: (1) Latin poems (1509-16); (2) letters and orations (1515-17); and (3) dialogues and letters, including his German writings (1517-23). See his *Opera Omnia* (7 vols. 1839-62), and lives of him by Strauss (4th ed. 1878; trans. by Sturge, 1874), Schott (1890), and others.

Hutter, LEONHARD, champion of Lutheran orthodoxy, was born in 1563 at Nellingen, near Ulm, and filled the chair of Theology at Wittenberg from 1596 till his death in 1616. His *Compendium* (1610) took the place of Melancthon's *Loci*, and his *Concordia Concordæ* (1614) was long a standard work. His name was adopted by Hase (q.v.) in his well-known rehabilitation of the Old Lutheran dogmatic, *Hutterus Redivivus* (1828; 12th ed. 1883).

Hutton, CHARLES, mathematician, son of a superintendent of mines, was born at Newcastle-upon-Tyne, 14th August 1737; from 1755 to 1773 was a teacher at Jesmond and Newcastle, and published works on arithmetic (1764), mensuration (1771), and bridges (1772). In 1773 he was made professor of Mathematics at the Military Academy, Woolwich, and in 1774 became F.R.S. His calculations for determining the density of the earth from Maskelyne's observations were published in the *Philosophical Transactions* for 1778. He resigned the professorship in 1807; and he died 27th January 1823.

Hutton's most important works are *Tables of Products and Powers of Numbers* (1781), *Mathematical Tables* (1785), *Mathematical and Philosophical Dictionary* (1795), *Course of Mathematics* (1798-1801), and *Recreations in Mathematics and Natural Philosophy* (4 vols. 1803—largely from the French).

Hutton, JAMES, one of the founders of geology, was born at Edinburgh, 3d June 1726. He studied medicine in his native city and at Paris and Leyden, but on his return home (1754) he settled in Berwickshire and devoted himself to agricultural pursuits and to chemistry, from which he was led to mineralogy and geology. In 1768 he removed to Edinburgh, and there spent his time in scientific investigations, and there he died, 26th March 1797. He read two important papers before the Royal Society of Edinburgh, *A Theory of the Earth* (1785; expanded to 2 vols. in 1795) and *A Theory of Rain* (1784). The upraised land of the globe must, he thought, be worn away by atmospheric influences, and the debris be finally deposited in the bed of the sea, where they are consolidated under great pressure; they are then forced upwards by subterranean heat acting with an expansive power, and thereby split and cracked, the fissures at the same time filling with molten mineral matter; and so the process goes on. The formation of rain he ascribed to the mingling of two strata of air of different temperatures and the subsequent condensation of the mixture.

He also wrote *Dissertations in Natural Philosophy* (1792), *Considerations on the Nature of Coal and Calm* (1777), and other works. See GEOLOGY.

Hutton, RICHARD HOLT, son and grandson of Unitarian ministers, was born at Leeds in 1826, studied at University College and School, London, and under Martineau at the Manchester New College. He was for some time a Unitarian preacher, became principal of University Hall, and contributed to Unitarian periodicals. Under the influence of F. D. Maurice he joined the Church of England, edited the new quarterly *National Review*, and taught mathematics in Bedford College. About 1860 he and Mr Townsend became associated as joint editors of the *Spectator* (founded in 1828), to which he gave the impress of his accomplished,

resolute, devout mind. He revered Cardinal Newman; had constant regard to ethical and religious interests in his judgments of men and movements, whether literary, social, or political; and greatly strengthened opposition to Irish Home Rule. His *Studies in Parliament* (1866), *Essays, Theological and Literary* (1871; new ed. 1880), and *Modern Guides of English Thought* (1887) were republished from the periodicals; his monograph on Scott ('Men of Letters,' 1878) was his least effective publication. His last years were clouded by the melancholia of his second wife, who, like his first, belonged to the Liverpool Roseoe family. He died 11th September 1897.

Huxley, THOMAS HENRY, biologist, born at Ealing, Middlesex, 4th May 1825, commenced his education at the school in that place, then a small village, and afterwards studied medicine in the Medical School of Charing Cross Hospital. In 1846 he entered the medical service of the royal navy, and did duty at Haslar, until the winter of the same year, under the late Sir John Richardson, by whose influence he was appointed assistant-surgeon of H.M.S. *Rattlesnake*. This vessel, commanded by Captain Owen Stanley, was commissioned to survey the intricate passage within the Barrier Reef skirting the eastern shores of Australia, and to explore the sea lying between the northern end of that reef and New Guinea. Huxley devoted himself with zeal to the study of the numerous marine animals collected during the survey, and made them the subjects of scientific papers, which were published by the Royal and Linnean societies. Towards the end of 1850 the *Rattlesnake* returned to England, and Huxley had the gratification to find that his paper *On the Anatomy and Affinities of the Family of the Medusa* had been published in the *Philosophical Transactions*. In 1851 Huxley was elected a Fellow of the Royal Society; in 1852 one of the two Royal medals annually given by the Society was awarded to him; and in 1853 he contributed to the Society's *Transactions* a memoir on the morphology of the Cephalous Mollusca. In 1854 he was appointed professor of Natural History, including Palaeontology, in the Royal School of Mines in place of Professor Edward Forbes, and held that office, combined with the curatorship of the fossil collections in the Museum of Practical Geology, until his retirement from the public service in 1885. It was part of the duty of the professor to deliver a course of six lectures to working-men every alternate year. Some of these have been published. In 1854 he published contributions to the anatomy of the *Brachiopoda*, in which some hitherto unsuspected peculiarities of their structure were described; and in this and the preceding year he wrote several essays on histological subjects. In 1856 he accompanied his friend Dr Tyndall in his first visit to the glaciers of the Alps, and his name appears as joint-author of a paper, *Observations on Glaciers* (*Phil. Trans.* 1857). In 1859 his large work on *The Oceanic Hydrozoa; a Description of the Calyptrophorida and Physophorida* observed during his voyage, was published by the Ray Society with illustrative plates. After his appointment to the Royal School of Mines, Huxley's attention was chiefly directed to vertebrate morphology and to palaeontology, with occasional excursions into the region of ethnology; but papers on the agamic reproduction and morphology of *Aphis* (1858), on the development of *Pycnosoma* (1860), a manual of the Invertebrata (1877), and classification and distribution of Crayfishes (1878) are evidence that the Invertebrata were not neglected. In vertebrate morphology the most important papers are the Royal Society's Croonian lecture, *On the Theory of the Vertebrate Skull* (1858); various papers on the

brain in man and apes, and on the relation of man to the lower animals, and *Man's Place in Nature* (1860-63); on the classification of Birds, and on the *Dinosauria* (1868-70); the article 'Amphibia' in *Ency. Britannica* (1875); *On Ceratodus* (1876); the cranial and dental structure of the *Cauder* (1880); *Lectures on Comparative Anatomy* (1864); *An Introduction to the Classification of Animals* (1869). In palaeontology, besides various papers on other fossil Invertebrata, memoirs on *Pterogotus* (1858) and *Belonites* (1864); a series of papers on *Staganolepis Robertsoni* and *Hyperolopetodon Gordonii* (1859-77-87); preliminary essay and descriptions of Fossil Fishes in the Decades of the Geological Survey (1862); *Glyptodon* (1863); Neanderthal Skull (1864); Reptilian Remains from India (1864); *Tetrapetodon* (1866); Amphibia from the Kilkenny Coal-measures (1867-71); *Hypsilophodon* and Evidences of Affinity between Reptiles and Birds (1869-70); *Chelonia* from Lord Howe Island (1887). In physiology, a short treatise, *Lessons in Elementary Physiology*. Essays on topics of a philosophical and general character are collected in *Lay Sermons*, &c. (1870); *Critiques and Addresses* (1873); *American Addresses and Physiography* (1877); a short work on *Haem* (1879); *Science and Culture* (1881); and *Science and Hebrew Tradition* (1894). His collected essays, with an autobiography, were issued in 9 volumes in 1893-95. A member of the Privy Council since 1892, he died at Eastbourne, 29th June 1895. His son Leonard wrote his *Life and Letters* (2 vols. 1900).

Huxley strongly advocated and greatly furthered Darwin's views and evolutionist doctrines in general, and was a keen and incisive critic of what he regarded as obscurantist theological prejudices. He held the offices of examiner in the university of London, of Fullerian professor at the Royal Institution, of Hunterian professor of Comparative Anatomy at the Royal College of Surgeons, of president of the Ethnological Society and of the British Association. He was secretary and president of the Geological Society, and secretary and president of the Royal Society. He was elected in 1873 Lord Rector of the university of Aberdeen, and a member of the London School Board in 1870. He was an active member of the Royal Commission on Sea-fisheries (1864-66), and served on several other commissions; and he was inspector of Salmon-fisheries from 1881 to 1885. He received the Wollaston medal, the Copley medal, and a Swedish order. Honorary degrees were conferred on him by Oxford, Cambridge, Würzburg, Brussels, Bologna, Breslau, Edinburgh, and Dublin. He was a foreign or corresponding member of the American, Brussels, Berlin, and French academies.

Huy, a town of Belgium, is romantically situated amid lofty rocks on both banks of the Meuse, 19 miles SW. of Liège by rail. Its citadel (1822), whose works are partly excavated in the solid rock, commands the passage of the river. The church of Notre Dame, a graceful Gothic edifice, was begun in 1311. In the vicinity are iron-works and coal-mines, and the manufactures include paper, leather, beer, spirits, &c. Pop. (1876) 11,774; (1890) 14,486. Peter the Hermit founded here the former Abbey of Nonfontier (*Noëum Monasterium*), and here in 1115 he died. Huy has been frequently besieged.

Huygens, CHRISTIAN, one of the great philosophers of the 17th century, was born at the Hague, April 14, 1629, and was the second son of Constantine Huygens, poet, diplomatist, and secretary to the Prince of Orange, who was knighted by James I. of England in 1622. Huygens studied at Leyden and Breda. His first work, *Theorematum de Quadratura Hyperbolæ, Ellipsis, et Circuli* (1651),

is an example of that powerful geometrical talent which lay at the foundation of all his scientific achievements. Soon after this he constructed the pendulum-clock, following out the idea first suggested by Galileo (see *HOROLOGY*). A complete description of Huygens' instrument is contained in his great work, *Horologium Oscillatorium* (1673). This work contains expositions of many of the cases of constrained motion, especially those applicable to the construction of timekeepers. Huygens also developed and gave precision to the investigations of Galileo upon accelerated motion under the action of gravity; and there is no doubt that to the clearness of his demonstrations his great successor, Newton, in preparing his magnificent development of the principle of accelerating force, was largely indebted. Newton was a student and admirer of his works, and assigns to him, along with Sir C. Wren and Wallis, the distinguished epithet of *hujus ætatis geometrarum favile principes*. By means of an improved telescope of his own construction, Huygens in 1655 discovered the ring of Saturn and the fourth satellite of that planet. In 1659 he published an account of these discoveries in a work entitled *Systema Saturnium*. In the end of this work the Micrometer (q.v.) is described. In 1660 Huygens visited England, where he was admitted a member of the Royal Society. He discovered the laws of collision of elastic bodies about the same time as Wallis and Wren, and also made a material improvement in the air-pump. But his most important discoveries are in the department of optics: he it was who first propounded and developed what is now known as the undulatory theory of Light (q.v.), and he is the discoverer of Polarisation (q.v.). The 'principle of Huygens' is a part of the wave-theory. In 1666 Huygens received an invitation to settle in France, with the promise of a pension from Colbert, then all-powerful in that country. At Paris he remained till 1681, a member of the Royal Academy of Sciences; but alarmed at the danger which seemed impending over the Protestants, he returned to his own country, and died at the Hague, 8th July 1693. His *Œuvres Complètes* have been issued since 1888 by the Amsterdam Academy of Sciences.

Huysmans, JORIS KARL, novelist, was born the son of a Dutch father at Paris 5th February 1848, and since 1866 holds a post in the French ministry of the interior. His first novel, *See au Dux* (1872), was followed by a series, all full of Zola's realism, till in 1895, when his works began to breathe a spirit of Catholic mysticism.

Huysum, JAN VAN (1682-1749), Dutch painter, was born and died at Amsterdam. His landscapes are conventional and artificial, but his fruit and flower pieces are exquisite.

Huzvaresh, the non-Iranian element in the Pehlvi dialect. See ZEND.

Hwen-tsang, or HUCEN-TSANG, a Buddhist monk of China, who was born near Honan about 605, and who in 629 set out on a pilgrimage to India, travelling by way of the Desert of Gobi, Tashkend, Samarcand, Bamian (q.v.), and Peshawar. He remained in India a period of thirteen years (631-44), visiting the sacred places connected with his religion, and studying its sacred books. He died in 664 in a convent at Chang-ngan (now Singan). Owing to the many curious notices he gives of matters which came under his observation, and the high degree of trustworthiness which his narrative possesses, his memoirs are regarded as one of the most important works on the history of India in general, and of Buddhism in particular, during the period stated. The account of his travels was written, not by himself, but under his supervision, and was completed in 618. According

to a remark added to the title in the imperial Chinese edition, the work would seem to have been translated from Sanskrit into Chinese; but this can only mean, as Stanislas Julien observes, that the fundamental part of the work relating to history, legends, &c., was taken from Hindu sources. Besides this book, there exists a biography of Hwen-Tsang written by two of his disciples. Both works were translated into French by Stanislas Julien (Paris, 1853 and 1857-58), and an abstract of these by H. H. Wilson appeared in the 17th volume of the *Journal of the Royal Asiatic Society*. See also *Hien Tsüing* in Trübner's Oriental Library (1888).

Hyacinth (*Hyacinthus*), a genus of plants of the natural order Liliaceæ; bulbous-rooted plants with corolla-like, bell-shaped, 6-cleft perianth, six stamens fixed in the tube of the perianth, and dry capsular fruit. The flower was fabled to have sprung from the blood of the beautiful Spartan Hyacinthus, beloved of Apollo and Zephyrus. Zephyrus, jealous because Hyacinthus favoured Apollo, caused Apollo's quoit to strike and slay the beautiful youth while the two were at play.—The Oriental Hyacinth (*H. orientalis*), one of the most favourite of florists' flowers, is a native of Asia Minor, Syria, and Persia. It is now naturalised in some parts of the south of Europe. It has broad linear leaves, and a scape with a raceme of many flowers pointing in all directions. The flowers in cultivation exhibit great variety of colour, chiefly blue, purple, and white. They are very beautiful and very fragrant. The fragrance is strongest about or after eleven o'clock at night. Among cultivated hyacinths are many with double flowers.

The hyacinth has been cultivated from a remote period. It was introduced into Europe, probably by the Dutch, about the beginning of the 16th century, soon after the revival of commerce, when the traders of Holland carried their merchandise to the eastern shores of the Mediterranean and the Archipelago. It was very little known in Britain till towards the beginning of the 17th century, but soon after its cultivation had become a passion with the wealthy, as it had for some time been with the Dutch. Extravagant prices—as much as £200—were paid for a single bulb of varieties having special or rare merits. This passion declined towards the middle of the 18th century, and the cultivation of the hyacinth became very much depressed. In recent years, however, it has been very much extended, and forms one of the principal industries of florists around Haarlem, which is and always has been the centre of the Dutch bulb trade; but their efforts are now directed with the view of meeting the demand of the million rather than the special requirements of the fanciful wealthy few. Hyacinth bulbs, planted in pots, readily produce beautiful flowers; and flowers almost equally beautiful are obtained for one year only, however, by placing them in water in hyacinth-glasses, in which they form a favourite ornament of apartments in winter and early spring. The cultivation of hyacinths in the open ground

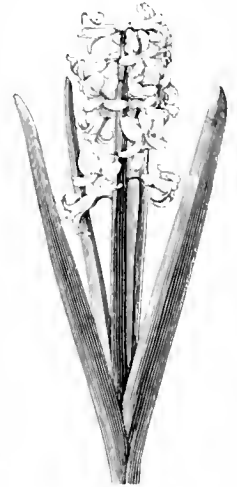

Hyacinth
(*Hyacinthus orientalis*).

is much more difficult, their early growth being liable to be destroyed by adverse weather. New varieties are raised from seed. Several other species of hyacinths are natives of the south of Europe, Africa, &c.—The Grape-hyacinth and Globe-hyacinth, frequently cultivated as garden flowers, are now referred to the genus *Muscari*.—A common British plant, growing in woods and copses, with beautiful blue flowers very like those of the oriental hyacinth, but all drooping to one side (*H. non-scriptas*, also known as *Scilla nutans*, *Eudymion nutans*, and *Agraphis nutans*), is sometimes called the Wild Hyacinth, and sometimes the Blue-bell (q.v.). The bulbs have been used for making starch.—The name hyacinth is also given to varieties of garnet, topaz, sapphire, and zircon.

Hyacinthe, PERE, is the former monastic name of CHARLES LOYSON, born at Orleans, 10th March 1827. He studied at St Sulpice, and in 1851 becoming priest, taught philosophy and theology at Avignon and Nantes. Subsequently entering the order of the Carmelites, he became known as a powerful preacher, and gathered crowded and enthusiastic audiences of all ranks of society to the Madeleine and Notre Dame in Paris. Almost as remarkable as his eloquence was the boldness with which he denounced existing abuses in the church; and Archbishop Darboy defended him against the accusations of the Jesuits till in 1869 the General of his order imposed silence on him. Hyacinthe replied by a letter in which he called for a thorough reform of the church, and was excommunicated. Relieved from monastic vows by the pope, he became a secular priest under the name of the Abbe Loyson. He protested vigorously against the Infallibility Dogma; but although he attended the 'Old Catholic' Congress at Munich, and on visits to the United States and England fraternised with Protestants, he always declared his intention to remain in the Catholic Church, trying to obtain reforms, such as the liberty of marriage for the clergy. In 1872 he married an American lady. In 1873 he was chosen curé of a congregation of Liberal Catholics at Geneva, but soon left them. He has published sermons and lectures, and in 1879 established a 'Gallican' congregation in Paris, which in 1884 attached itself to the Old Catholic Church in Holland.

Hyades, in Greek Mythology, the nurses and guardians (3, 5, or 7 in number) of young Dionysus. Zeus converted them into stars and transplanted them to the heavens, where they form the head of the constellation Taurus. Their rising with the sun was held in Greece to mark the beginning of the rainy season.

Hyæna, a genus of digitigrade carnivorous quadrupeds, included in the genus *Canis* by Linnaeus, but now referred to the Elmoïd division of the Carnivora, of which, however, it is a somewhat aberrant member, forming with *Proteles* (q.v.) a sub-family, Hyænina. Hyænas have six incisors and two canine teeth in each jaw, five molars on each side in the upper jaw, and four in the under. They seize an object with so firm a hold that, among the Arabs, they are proverbial for obstinacy. The vertebrae of the neck sometimes become ankylosed in old hyænas. The hind-quarters are lower and weaker than the fore-quarters of the body, so that hyænas move with a shuffling gait. The body is covered with rather long coarse hair, forming a mane along the neck and back. The feet have each four toes. The claws are strong, fit for digging, and not retractile. The tail is rather short. Beneath the anus is a deep glandular pouch, contributing much to the offensive odour by which hyænas are characterised. Hyænas eat carrion, as well as newly-killed prey, and are of much use, like

vultures, as scavengers, clearing away the last remnants of carcasses that if left to rot would greatly pollute the air. They sometimes attack cattle, especially if they flee, but rarely man, though they sometimes seize children. During the day they hide themselves in caves, old rock-tombs, ruined edifices, &c.; by night they roam singly or in packs in quest of prey. They prowl about towns and villages, and often dig up corpses that have not been very deeply buried. This, together with their aspect and manners, has caused them to be generally regarded with horror, and very exaggerated accounts of their fierceness have been prevalent. Instead of being untaimable, as was long the popular belief, they are capable of being very completely tamed, and show an attachment to man similar to that of the dog; they have even been used as watch-dogs. Hyænas are found only in Africa and the south of Asia, not extending to the furthest east of the latter continent.—The Striped Hyæna (*H. strata*) is found both in Asia and Africa, and there are several varieties considerably different in size, colour, &c. The smallest hyænas are of the size of a large dog. The Spotted Hyæna (*H. crocuta*) inhabits South Africa. It is rather smaller than the largest varieties of the striped hyæna, but is more fierce and dangerous. It is called Tiger-wolf by the colonists of the Cape of Good Hope.

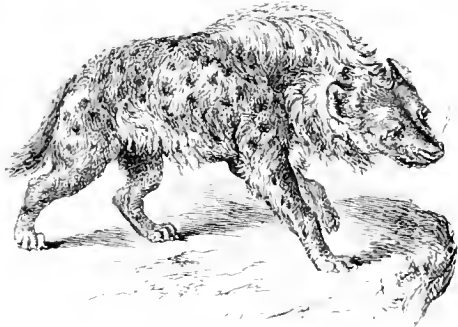

Spotted Hyæna (*Hyæna crocuta*).

Besides its ordinary howling, which it emits very freely in its nocturnal roamings, this hyæna often indulges in an expression of gratification or of some passion, resembling hysterical laughter, whence it has acquired the name of the Laughing Hyæna. The general colour is ochry gray, with thinly scattered small round brown spots, and sooty muzzle and feet. The Woolly Hyæna (*H. brunnea*) is a smaller South African species.

In consequence of the bones which hyænas eat, their dung forms solid yellowish-white balls, of compact earthy fracture, the *Album graecum* of the old materia medica. For the Hyæna Dog, see Dog.

Hyæ-hyæ. See COW-TREE.

Hybla, the name of three cities of ancient Sicily. (1) An old Sicilian town situated on the southern slope of Mount Etna, which figured in the second Punic war; its site is fixed at the modern Paterno.—(2) A city founded by the Megarians about 726 B.C., and probably identified with the city called Megara. It was destroyed by Gelon of Syracuse in 481 B.C. It is believed to have stood near the modern Agosta.—(3) A third Hybla lay between Syracuse and Agrigento. The Hyblæan honey, so much sung by Latin poets, was gathered on the hills near the first two cities.

Hybrid (Gr. *hybris*, 'lust'), the offspring of two parents which belong to different varieties, or to different species, or even to different genera. Thus, according to the degree of divergence

between the parents, variety-hybrids, or mongrels, species-hybrids (the usual application of the term), and genus-hybrids, which are very rare, have to be distinguished. It is also useful to note with Broca that hybridisation may be (a) *natural*—i.e. occurring in undisturbed natural conditions, of which we know relatively few cases; (b) *incited*—i.e. under direct human control, on which our data as regards animals are chiefly based; and (c) *artificial*—i.e. by placing the pollen of one plant on the stigma of another species, or by mixing with the eggs of some animal, say frog or fish, the male elements of some related form.

Among mammals genus-hybrids find illustration in the successful crossing of he-goat (*Capra*) and ewe (*Ovis*), the offspring being fertile for several generations, both *inter se* and with the parent-stocks. Species-hybrids are well illustrated in the results of crossing various members of the genus *Equus*—e.g. male ass and mare, the offspring being a mule; or horse and female ass, the offspring being a hinny. Similarly, dog and fox, dog and jackal, lion and tiger, hare and rabbit, Indian lumped cattle and our very different domesticated breeds, and not a few other more or less nearly related forms have been successfully crossed. For such names as 'leopard,' which suggest that crossing occurs or occurred somewhat freely in nature, there is little or no evidence. Nor was there any truth in the supposition that 'Jumarts' resulted from the crossing of bull and mare, or stallion and cow, for Jumarts turn out to have been nothing more than hinnies.

Among birds the common duck (*Anas boschas*) and a pintail (*Dafila acuta*), the common goose (*Anser ferus*) and the very distinct Chinese goose (*A. cygnoides*), goose and swan, canaries and finches, pheasant and hen, and other allied forms are recorded as giving rise to hybrids. Among lower animals hybrids also occur; different species of toad are often seen in sexual union, but the result is unknown; the artificial fertilisation of frog ova with the sperms of other species has at least resulted in the development of hybrid tadpoles; in several fishes hybridisation seems to occur in natural conditions, and artificial fertilisation has been effected even between genera, to the extent at any rate of starting the development of the ova. The hybrids of two moths (*Bombyx cyathia* and *B. arctiada*) have been recorded as fertile *inter se* for eight generations; and R. Hertwig has shown that in certain conditions the male elements of one species of Echinoderm may incite development in the ova of another.

Hybridisation in Plants. Experiment is here much easier, and a large mass of data has rewarded the investigations of Kohreuter (1761), Andrew Knight, Dean Herbert, Gartner, Wichura, Hildebrand, Focke, and others. The subject received careful disquisition from Darwin in his work on cross fertilisation, and also from Nageli, a summary of whose conclusions is available in the English translation of Sachs's *Text-book of Botany*. Only the leading results can be noted here. Hybridisation rarely occurs except between forms known to be related; variety-hybrids occur easily and abundantly; species-hybrids are less, though quite common; genus-hybrids (e.g. between the grasses, *Egilops* and *Triticum*, between *Rhododendron* and *Azalea*, between *Lycnis* and *Silene*) are rare. Besides genetic relationship, some subtle harmony, which we can only call 'sexual affinity,' is essential to successful hybridisation. When one species can be fertilised by the pollen of another, the *vice versa* relation usually holds good; but sometimes the hybridisation is persistently one-sided. Kohreuter easily obtained seeds from *Micaulis jalapa* with the pollen of *M. longiflora*, while more than two hundred experiments, extending

over eight years, with the pollen of the former upon the stigma of the latter were futile. The results of hybrid fertilisation exhibit many degrees; thus, the mother-plant may be affected by the strange pollen without seeds being produced, or seeds may be formed which will not germinate, or numerous, vigorous, and fertile hybrids may result. When two kinds of pollen are simultaneously applied to the stigma only one kind is potent. The hybrid is usually intermediate between the two parents, not only in structural features, such as the venation of the leaves and the shape of the flower, but in physiological peculiarities, such as the time of flowering and the mode of coloration. Focke reports a curious case where the crossing of *Anagallis carrollae*

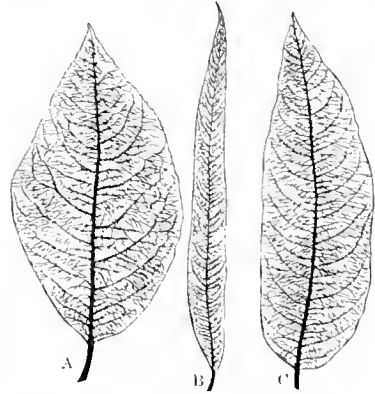

Hybrid Leaves:

A, leaf of *Salix caprea*; B, of *S. viminalis*; C, of hybrid between these two species. (After Wichura.)

and *A. phoenicea* produced hybrids which bore in part the blue flowers of the former species, and in part the reddish flowers of the latter. Hybrids are usually more variable than the parents, and the variation may be towards strength or towards weakness. Since Fairchild, at the beginning of the 18th century, first intentionally produced a cross between *Dianthus barbatus* and *D. caryophyllus*, hybridisation has often been resorted to by gardeners and arboriculturists to produce a strong stock. Very important are the numerous hybrids between European and American vines, some of which are believed to be endowed with greater powers of resisting Phylloxera and fungi than the unaltered European plants possess. There can be no doubt that species-hybrids among plants tend to be sterile, and this the more the wider the difference between the parent plants. Sometimes three or even six individualities have been gradually mingled in a multiple hybrid, and this lessens still more the chance of fertility.

Character of Hybrids.—The products of crossing, whether of species or of varieties, are undoubtedly very variable, sometimes for the better as in many of our domesticated mongrels among both animals and plants—very often on the other hand for the worse. They are often so unstable that they tend rapidly to die out, as has been observed among some human experiments in mingling races. The saying 'God made the white man, God made the black man, the devil made the mulatto,' expresses a feeling as to the frequently inconvenient variability of variety-hybrids, but there is much to be said on the other side. Such a case as sheep-goat hybrids shows how far from accurate is the still prevalent belief that hybrids from widely separated parent forms must be sterile. We are by no means warranted in saying more than that species-hybrids tend to be sterile so far as we

know them, and that it must be remembered is for the most part in conditions of domestication, where the resulting sterility may have been due to confinement, and to prolonged interbreeding, rather than to the hybridisation itself. Nor do the facts allow us to accept the further generalisation that variety-hybrids are always fertile. Not only are there cases of the reverse, but, as Wallace justly points out, the conclusion was again based on domesticated forms, in regard to which it must be noted that the very first essential to their becoming domesticated was that they should continue fertile under changed conditions of life.

Hybrids in Relation to Evolution.—The facts of hybridism raise some of the most intricate problems connected with evolution. As only a few general statements can be noted here, the reader is referred to the cited work of Alfred Russel Wallace. (1) Fertility or non-fertility of crosses must not be exaggerated into the test between variety and species, for all species-hybrids are not sterile, nor all variety-hybrids fertile. (2) Fertility depends on some delicate mutual adjustment or complementariness of the male and female elements, and is readily disturbed by external or constitutional conditions. (3) Animals seem to prefer to breed with their like among existing varieties, and in this way it is believed that the 'swamping effects of intercrossing' have been usually obviated, though mutual infertility and geographical separation may also assist in preserving the varieties. (4) Brooks has laid stress upon the fact that both variety and species hybrids are highly variable. In his theory of 'physiological selection,' Romanes has emphasised the importance of mutual sterility in splitting up one species into several. 'Whenever any variation in the highly variable reproductive system occurs, tending to sterility with the parent form without impairing fertility with the varietal form, a physiological barrier must interpose, dividing the species into two parts, free to develop distinct histories, without mutual intercrossing, or by independent variation.' (5) Darwin concluded that 'the sterility or infertility of species with each other, whether manifested in the difficulty of obtaining first crosses between them, or in the sterility of the hybrids thus obtained, was not a constant or necessary result of specific difference, but is incidental on unknown peculiarities of the reproductive system.' Wallace has advanced a step further in his endeavour to show that 'if we accept the association of some degree of infertility, however slight, as a not unfrequent accompaniment of the external differences which always arise in a state of nature between varieties and incipient species, natural selection has the power to increase that infertility just as it has the power to increase other favourable variations.'

See BREED, DOMESTICATION, EMBRYOLOGY, EVOLUTION, REPRODUCTION, SEX, SPECIES; P. Broca, *Ann. d. l. Physiol.*, vols. i. ii. iii.; W. K. Brooks, *Heredity* (Baltimore, 1883); Darwin, *Plants and Animals under Domestication* (Lond. 1868), and *Effects of Cross and Self Fertilisation* (Lond. 1877); Focke, *Die Pflanzenmischlinge* (Berlin, 1881); Geddes and Thomson, *Evolution of Sex* (Lond. 1883); V. Hensen, *Physiol. d. Zeugung*, in Hermann's *Handbuch d. Physiologie* (Bt. vi. Leip. 1881); G. J. Romanes, *Ann. Linn. Soc. XIV.* (1886); J. Sachs, *Text-book of Botany* (Oxford, 1882); cf. his references to Kolreuter, Herbart, Gartner, Nägeli, &c., and *Physiology of Plants*, trans. by Marshall Ward (Oxford, 1887); A. R. Wallace, *Darwinism* (Lond. 1889); Wichura, *Bastardbildung in Pflanzenreiche* (Breslau, 1865).

Hydaspes. See JHELUM.

Hydatid (from the Greek *hydatis*, 'a watery vesicle'), a term applied to the bladder-worm (*scælaræ*) stage of certain tapeworms, but particularly to that of *Tænia echinococcus*, found especially in

man and monkeys, ox and swine, in liver, lungs, or almost any organ. The bladder-worm (*Echinococcus cerebrorum*) is often very conspicuous, from the size of a pea to that of a child's head, weighing in some cases 12 to 30 lb., and notable among bladder-worms for its prolific asexual multiplication. From the inner surface, in numerous special brood-capsules of the size of millet-seed, sometimes hundreds of 'heads' are huddled off; while daughter-bladders may also be produced externally.

The adult tape-worm is small, and lives socially in the intestines of dog, jackal, or

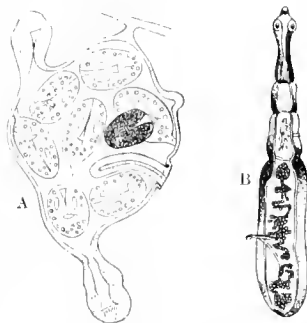

A, brood-capsule of *Echinococcus cerebrorum*, with fully-formed and rudimentary heads; B, adult *Tænia echinococcus*.

wolf. It is from the dog being kept too much about the house or person that the eggs which give rise to the dreadful *Echinococcus* find their way to man. The disease is known in most countries of Europe, but is commonest in Iceland. The term hydatid is sometimes extended to other bladder-worms—e.g. the 'stagger-worm' (*T. caninus*) of the sheep, or in medicine to serous cysts which have nothing at all to do with parasites. See TAPEWORM; and for a very full discussion of *Echinococcus*, see Lenekart's *Parasites of Man* (trans. by W. E. Hoyle, vol. i. Edin. 1886).

Hyde, an important manufacturing town of Cheshire, 7 miles ESE. of Manchester, and 5 NE. of Stockport. Standing in a coalfield, and enjoying ample facilities of communication by road, rail, and canal, it has risen from a mere village to a considerable town, which in 1881 was incorporated as a municipal borough. Cotton is of course the staple manufacture; then come the felt-hat industry, engineering, boiler-making, &c. The town-hall is a handsome building. Pop. (1811) 1806; (1861) 13,722; (1891) 30,670.

Hyde, EDWARD. See CLARENDON (EARL OF).

Hyderabad (*Haidarabad*), or the NIZAM'S DOMINIONS, a great native or feudatory state of India, occupies the greater part of the Deccan proper or central plateau of southern India, between the provinces of Madras and Bombay. Area, 81,807 sq. m. (excluding the British assigned districts of Berar, q.v.); pop. (1881) 9,845,594; (1891) 11,537,040. About a tenth only are Mohammedans, found mainly in the capital, though the Nizam and state are Mohammedan. Telugu, Kanarese, and Marathi are the principal languages spoken. Education is making rapid strides; during the three years previous to 1889 the number of schools nearly doubled, and the pupils increased from 11,740 to 27,700. The surface is a slightly-elevated tableland. The principal rivers are the Godavari, with its tributaries the Dudna, Manjira, and Pranrita; and the Kistna (Krishna), with its tributaries the Bhima and Tungabhadra. The soil is in general very fertile, but poorly cultivated; yet, wherever it receives moderate attention, it yields harvests all the year round. The products are rice, wheat, maize, mustard, castor-oil, sugar cane, cotton, indigo, fruits (including grapes and melons), and all kinds of kitchen vegetables. The pasturages are extensive, and sheep and horned cattle are numerous. The climate is good on the whole.

The mean temperature of the capital, Hyderabad, in January is 74° 30', and in May 93°. The exports are cotton, oil-seeds, cloth, hides, metal wares, and agricultural produce; salt, grain, timber, European piece-goods, and hardware are imported. The railway from Madras to Bombay intersects the south-west part of the state. The state revenue is about £4,000,000 a year; and there is an army of 13,000 infantry and 1400 cavalry, besides a large force of irregulars (possibly some 48,000 constitute the military force).

In 1687 the territory long known as the Nizam's Dominions became a province of the Mogul empire; but soon after 1713 the governor or viceroy of the Deccan, Asaf Jah, with the title of *Nizam-ul-Mulk* ('regulator of the state'), made himself independent. After his death, in 1748, two claimants appeared for the throne, his son Nasir Jang, and his grandson Muzaffar Jang. The cause of the former was espoused by the East India Company, and that of the latter by a body of French adventurers under General Dupleix. Then followed a period of strife and anarchy. In 1761 Nizam Ali obtained the supreme power, and after some vacillation signed a treaty of alliance with the English in 1766. He aided them in the war with Tippoo, sultan of Mysore, and at the termination of that war, in 1799, a new treaty was formed, by which, in return for certain territorial concessions, the East India Company bound itself to maintain a subsidiary force of 6000 men for the defence of the Nizam's dominions. Another treaty was concluded in 1853. The Nizam, who in point of rank is the first Mohammedan ruler in India, remained faithful to the British during the mutiny of 1857-58 (see JUNG, SIR SALAB). The assigned districts (see BEGAR) were in 1861 given in trust to Britain on account of unpaid and increasing debts; the surplus revenue being returned to the Nizam.

Hyderabad (*Haiderabad*), the capital of Hyderabad state, stands on the right bank of the Musi, at an elevation of 1700 feet above the sea, by rail 390 miles N.W. of Madras. It is 6 miles in circumference, and is surrounded by a stone wall, flanked by bastions. In 1891 the population, inclusive of the suburbs, was 415,039. The populace consists of very varied elements, and is full of war-like spirit, nearly every one carrying weapons. The street architecture is uninteresting. The palace of the Nizam, though architecturally of no great importance, is of vast size. Hyderabad is one of the most important strongholds of Mohammedanism in India, and the mosques are numerous. The principal mosque was fashioned after the model of the Great Mosque at Mecca; in the interior are fine monolithic granite columns, and outside the building is crowned by very lofty minarets. Another remarkable edifice is the Char Minar or College, with four minarets resting on four connected arches, at which the four principal thoroughfares converge. On the opposite side of the river is the British Residency, a magnificent pile, with the finest staircase in India; it stands in the midst of fine ornamental gardens, and communicates with the Nizam's palace by a bridge with eight spacious arches of squared granite. The neighbourhood boasts of wild and picturesque scenery, and abounds with huge tanks and beautiful gardens. Secunderabad (*Sikandarabad*) is a British military cantonment (pop. 1881, 74,124) 6 miles N.E. of Hyderabad.

Hyderabad, the historical capital of Sind, and chief city of a district, stands 32 miles E. of the left bank of the Indus. Pop. (1891) 58,048, of whom 25,000 were Mohammedans. The town is the main centre of postal, telegraphic, and road communication for the province, though the Sind railway, terminating at Kurachee, is on the other

side of the Indus. It is famous for the manufacture of silks, gold-work, pottery, lacquered ware, and arms of various kinds. There is now a plentiful water-supply from the Indus. As against a native force it is tolerably strong, occupying a somewhat steep height, and having a rampart flanked by round towers.

Hyder Ali (*Haider Ali*), ruler of Mysore, and one of the greatest Mohammedan princes of India, was born in 1728. His grandfather was a wandering fakir; his father a constable of a district in Mysore. Hyder spent his youth in idleness, though occasionally doing military service; but in 1749 his bravery at a siege attracted the notice of the maharajah of Mysore's minister. He soon became in all but name ruler of the kingdom; and in 1759 he dispossessed his master, allowing him to retain his title, while he himself took that of *dawra*, or regent. He then conquered Calicut, Bednor, Kanamur, and other neighbouring states; and in 1766 his dominions included more than 84,000 sq. m. He withheld the customary tribute from the Mahrattas (q.v.), and carried on an ultimately successful war against them. He waged two wars against the British, in the first of which (1767-69) he was practically successful, and signed a treaty under the walls of Madras, which provided for a kind of alliance. When Hyder was defeated by the Mahrattas in 1772 he claimed English support; and on the refusal of the Madras government to fulfil what he believed to be the treaty obligations, he became the bitter enemy of the English. Taking advantage of the war between the English and French (1778), he and his son and successor, Tippoo Saib, descended like a thunderbolt into the Carnatic, totally routed two English commanders, and ravaged the country to within forty miles of Madras; but he was ultimately defeated in three battles by Sir Eyre Coote. He died suddenly, still in alliance with the French, in December 1782. See L. B. Bowring, *Haider Ali and Tippu Sultan* (1893).

Hydnora, a genus of parasitic plants belonging to the order Cytinaceae, which consists entirely of root-parasites. *Hydnora africana* is a South African species parasitic on the roots of fleshy Euphorbiac and other succulent plants; it has a putrid smell, but is roasted and eaten by the natives, and is also used for tanning.

Hydnum, a genus of fungi belonging to the sub-order Hymenomyces, order Basidiomycetes, and having the under side of the *pileus* covered with soft spines which bear the spores. The species are numerous, some of them British; among these is *H. repandum*, more common in some parts of the continent of Europe, and much used as an esculent in France, Italy, and Germany. It grows chiefly in pine and oak woods.

Hydra, a Greek island, lies 4 miles from the coast of the Peloponnesian department of Argolis and Corinth. It is a narrow rocky ridge, 11 miles long, 1960 feet high, and 20 sq. m. in area. The shores are rocky and steep, and the interior is destitute of vegetation and of water. On the north-west coast is the seaport of Hydra (6446). The 7342 islanders, mostly of Albanian origin, make excellent seamen, and carry on cotton and silk weaving, tanning, shipbuilding, sponge-fishing, and commerce. The island was uninhabited in ancient times. Previous to the war of Greek independence the Hydriotes numbered more than 28,000, and were considered the richest people in the archipelago. They enjoyed a large share of the carrying-trade in the Black Sea and the Mediterranean, and traded to England, the Baltic, and even America. In the war they took a most active and conspicuous part; but on the restoration

of peace the island lost much of its former prosperity, being outrivalled by Syra.

Hydra, a fabulous monster of the ancient world, said to have inhabited the marshes of Lernæa, in Argolis, not far from the sea-coast. Accounts vary both as to its origin and appearance. Some make it the issue of Styx and the Titan Pallas, and others, of Echidna and Typhon. It is represented as having several heads, which immediately grew up again as often as they were cut off. The number generally ranged from seven to nine, though Simonides gives it fifty, and some historians a hundred, and even more. Its mouths, which were as numerous as its heads, discharged a subtle and deadly venom. The destruction of this reptile was one of the twelve labours of Hercules.

Hydra, a fresh-water polyp, the simplest and most familiar representative of the class Hydrozoa (q.v.), sub-kingdom Cœlenterata (q.v.). The animal consists of a tube, varying from $\frac{1}{4}$ to $\frac{1}{2}$ inch in length, closed at the proximal end by an adhesive plate (pedal disc), whereby it is commonly attached to some water weed; at the other (distal) extremity is the mouth, at the apex of a blunt cone (hypostome), round whose base arise from six to

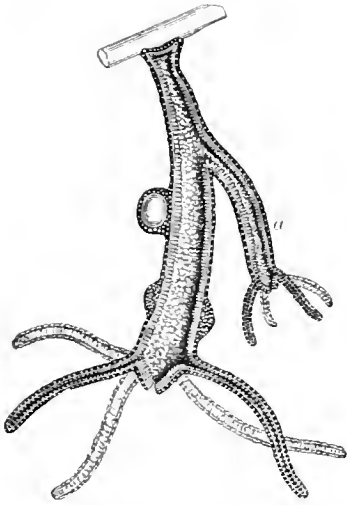

Fig. 1.

Semi-diagrammatic longitudinal section of an adult specimen, with reproductive organs and a bud (*b*); magnified eight diameters. (After Marshall and Hurst.)

eight tentacles. These are slender tubes closed at the end, but continuous internally with the main cavity of the animal; they have a warty appearance and, according to their degree of contraction, may be either small rounded nodules or stretch out to several times the length of the body. The prey, which is lacerated by the thread-cells to be presently described, is drawn by the tentacles into the mouth. The body-wall consists of three distinct layers: 1. The Ectoderm, or outer covering, consists of the following kinds of cells: (1) covering cells in a single layer, subconical, with the broader ends outwards. (2) Muscle-cells, whose base forms a filament, disposed longitudinally. (3) Interstitial cells, small, rounded and placed in groups between the bases of the larger cells. (4) Endoblasts, so called because they contain the thread-cells (endocysts, nematocysts). These latter have rather a complicated structure; they consist of an ovoid sac, at the outer end of which the wall is invaginated or tucked in to form a long tube coiled up like a string; the commencement of the invaginated

portion contains some pointed barbs, the end is filiform and pointed. The young endoblasts, in which the development of the thread-cells is just beginning, are situated deeply among the interstitial cells; when mature they are placed on the surface, and form noticeable prominences between the covering-cells; the endoblast remains as a sharply-defined capsule round the thread-cell, and near the aperture of invagination it gives out a little process (endocil), which seems to serve the purpose of a trigger, for upon touching it the tube contained in the thread-cell is suddenly everted, and then presents the appearance of a long pointed filament, with barbs, disposed in circles of three each, at its base. It is, however, only certain forms of irritation which produce this effect; it seems to be under the control of the nervous system. (5) Nerve-cells,

with numerous processes, some of which are continuous with the endoblasts. (6) Glandular cells, which are restricted to the pedal disc. II. The Endoderm, or internal layer, consists of three kinds of ciliated cells: (1) a layer of large cells which often contain granules of greenish matter resembling that of leaves (chlorophyll). They have the power of throwing out processes (pseudopodia) during digestion, and almost always have empty spaces or vacuoles in them; they may furthermore give rise to muscular filaments, both circular and longitudinal. (2) Small glandular cells in the hypostome. (3) Glandular cells with vacuous spaces at the base of the body-cavity. III. The Mesoderm is a thin structureless lamella, separating the ectoderm and endoderm.

The hydra reproduces by two distinct modes: (1) asexually by gemmation. When the weather is warm and food abundant, a hollow outgrowth takes place from the side of the body of the parent; a mouth and tentacles are formed at its distal extremity, and eventually it separates by constriction of its base, and commences an independent existence. Several buds may form at once, and these may even produce secondary buds before their separation from the parent, but this formation of colonies is merely temporary. (2) Sexual reproduction takes place when the conditions of life become unfavourable—e.g. if a hydra which has just begun to bud be placed in a vessel in which food is scarce, sexual organs will be formed and the bud will not improbably be absorbed. The male organs (testes) are conical swellings, situated not far below the tentacles; generally they are more than one in number. They arise by the multiplication of the interstitial cells of the ectoderm, and when mature their contained spermatozoa are shed into the water. The ovum is as a rule single, and is due to the development of one of a mass of interstitial cells; the surrounding cells form a protective capsule which eventually retracts and leaves the most prominent part of the ovum bare to receive the spermatozoa. After this the ovum undergoes segmentation, a hard capsule is formed around it, and it falls to the bottom and there develops into a young hydra. Prior to sexual reproduction the hydra often retires into the shade

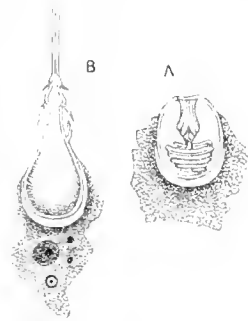

Fig. 2.

A, a thread-cell with the thread not everted; highly magnified. B, a thread-cell, after the evagination of its contents; highly magnified. The filament, if completed on the scale of the drawing, would have a length of 12 inches. (After Gibson.)

of moss or similar dark objects. As regards its reproductive organs it seems most probable that hydra has undergone great modifications as compared with other hydrozoa, and that its simplicity is not primitive but the result of degeneration. The food of hydra consists of organisms more minute than itself, which it is able to paralyse by its thread-cells; after the nutritive portion of these has been extracted the effete portions are ejected through the mouth. The animal can creep slowly upon its disc and swim by the same organ, hanging suspended below the surface of the water; it creeps by bending the body, attaching a tentacle to the surface upon which it rests, and then moving the foot up to the tentacle and refixing it.

Various species of the genus Hydra have been described, as *H. viridis*, *H. fusca*, and *H. vulgaris*. The first is distinguished by the presence of green chlorophyll granules in the cells of the endoderm. It has been maintained that these were algae living within the cells in a state of Symbiosis (q.v.), but the facts that the green hydra does not lose its colour in the dark, that the coloured bodies have neither nucleus nor cell-membrane, and that they are found in the ovum where they originate from colourless bodies, tend to prove that they are integral parts of the animal.

If a hydra be cut in two, it appears that within certain limits each portion will develop into a complete animal; but the statement so often repeated, as the result of Trembley's experiments, that when a hydra is turned inside out the endoderm and ectoderm will mutually take on each other's functions, and the animal continue to live, is erroneous; the animal will, on the contrary, rectify its position, or, if prevented, it will perish. When a hydra captures a fragment of food too large to be taken into the mouth, it everts the endoderm so as to bring the digestive cells in contact with the food, but it speedily regains its original state; this explains the power it has of rapidly recovering after artificial inversion. Two hydræ can be permanently fused with each other either by pinning them together with bristles or by inserting one inside the other.

List of more important references in addition to the ordinary text-books of zoology: Kleinberg, *Hydra* (Leip. 1872); Jékeli, *Morphologisches Jahrbuch*, viii. (1882-83); Parker, *Proc. Roy. Soc.*, xxx. (1880); Lankester, *Nature*, xxvii. (1882-83); Korotnev, *Ann. and Mag. Nat. Hist.* (5) xi. (1885); Ischikawa, *Zeitschr. f. wiss. Zool.* xlix. (1890).

Hydragogues. See APERIENTS.

Hydrangea, a genus of plants of the natural order Hydrangeaceæ, which many botanists make a sub order of Saxifragæ, distinguished by having four to six petals, eight to twelve or many stamens, a more or less inferior ovary, and two to five styles. In hydrangea the flowers are in cymes, the exterior flowers sterile and dilated. Few species are known, and they are chiefly natives of the southern parts of North America, and of China and Japan. The species popularly known as the Hydrangea (*H. hortensis*) is a native of China and Japan, and has long been in cultivation there as an ornamental plant. It was introduced into Britain by Sir Joseph Banks in 1788, and speedily became very popular, being readily propagated by layers and cuttings, so as to be not only a favourite greenhouse plant, but a frequent ornament of cottage windows. In the south of England, and south-west of Scotland, it endures the open air. It seems almost impossible to water it too freely; and in favourable circumstances it becomes a magnificent shrub. A plant in Devonshire has had 1000 large cymes of flowers expanded at once. The flowers, generally pink, are sometimes blue; the blue colour is owing to peculiarities of soil.

Peat and iron ore are said to be productive of blue flowers in the hydrangea. *H. Japonica*, introduced into Europe from Japan by Siebold, is remarkable



Hydrangea (*Hydrangea hortensis*).

for its very large cymes of flowers.—*H. nirea* and *H. quercifolia*, American species, are not unfrequently to be seen in flower-gardens in North America.

Hydrates are compounds of water with elements or with other compounds. The term *hydroxide* is one which is sometimes used as a synonym of *hydrate*, and indeed it may be said that we have no certain means of distinguishing the one from the other. The distinction between the two is that in the hydrate the water is supposed to be present as water, and without any rearrangement of the molecules, while in the hydroxide the water is considered to have lost its identity, its constituent atoms having entered into new combinations. As a typical example of a hydrate we may instance crystallised sulphate of copper, $\text{CuSO}_4 \cdot 5\text{H}_2\text{O}$, which contains the water so loosely combined that it is driven off by prolonged heating, and the white anhydrous sulphate, CuSO_4 , is produced. Here the water is apparently present as water, and necessary to the crystalline form, and is therefore called water of crystallisation. When nitric anhydride, N_2O_5 , unites with water it forms nitric acid, $\text{N}_2\text{O}_5 \cdot \text{H}_2\text{O}$ or HNO_3 , but this is not regarded as a hydrate, because the nitric acid cannot lose the water without also losing its characteristic properties. The whole question is full of difficulties, and is at present quite theoretical; different chemists using the terms above mentioned in different senses.

Hydraulic Cranes. See CRANES.

Hydraulic Engines or Motors are often conveniently used when water under a high pressure is obtainable, and where work is intermittently required, as in capstans, winches, &c.; they do not differ essentially from steam engines. The water acts by difference of pressure, i.e. it is admitted at a high pressure at the beginning of the stroke, and exhausted at a low pressure at the end of the stroke, thus giving a reciprocating motion to the plunger. The velocity of the piston has to be kept low to avoid injurious shocks in suddenly bringing the column of water to rest; since they work under very much greater pressures than steam engines (usual pressure 700 lb. per sq. in.), they can be much smaller. A common form is the three-cylinder single-acting engine; in each cylinder works a plunger; water is admitted by valves behind the plungers and forces them out; at the conclusion of the out-stroke the pressure water-supply is cut off, and the

exhaust valve opened, allowing the plunger to push the water out of the cylinder on the return stroke, and so on. There are two chambers in the framing, and one passage or port into the bottom of the cylinder; during the working of the engine the cylinder oscillates, and at the right time puts one or other of the two chambers in communication with the interior of the cylinder by means of this port; one chamber is open to exhaust-pipe, the other to supply-pipe. The plungers are connected to a three-throw crank. The great advantage of the single action is that shocks are avoided at the dead centres; the three cranks ensure a very uniform turning force on the crank shaft, and also enable the engine to start in any position.

Hydraulic Main. See GAS.

Hydraulic Mortar. See CEMENTS.

Hydraulic Press, often called Bramah's press, from the inventor, Joseph Bramah (q.v.), depends for its action on the principle that a pressure exerted on any part of the surface of liquid is transmitted undiminished and equally

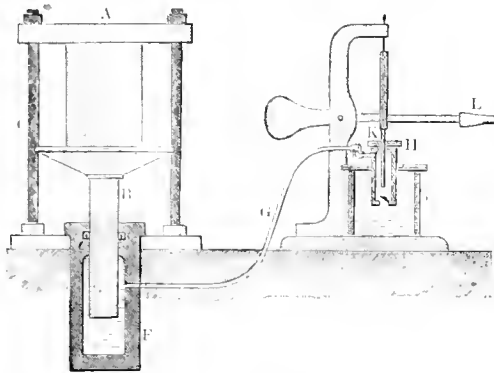

Hydraulic Press.

in all directions through the mass (see HYDROSTATICS). The annexed figure represents the essential parts of the machine, minor details of construction being omitted. F is a strong cast iron or cast-steel cylinder, open at the top; B is a plunger or ram which fits watertight into the cylinder; to prevent leakage a leather ring U-shaped in section is placed in the cavity *c*; any water trying to leak out forces the two sides of this ring hard against the piston and the side of the cavity, and the greater the pressure the tighter it keeps. This form of packing is now often replaced by an ordinary stuffing-box filled with hemp packing. A pipe, G, leads from the cylinder to a force-pump, H. By means of this pump water can be forced from the tank, T, through the pipe G into the cylinder, thus pushing the plunger or ram, B, upwards. The ram carries on its top a platten or table, on which the bales, &c., to be pressed are placed; the rising of the platten presses them against the entablature or upper plate, A, which is held in position by the columns C. The bale can thus be squeezed to any extent desired.

The power of the press is readily calculated; let the diameters of the pump plunger, K, and ram, B, be *d* and *D* inches respectively, then any downward pressure on K becomes an upward pressure on B magnified $\frac{D^2}{d^2}$ times. Suppose, for instance, that the pressure on K was 500 pounds, and that the diameters are 1 and 10 inches respectively, then the upward thrust would be $500 \cdot \frac{10^2}{1^2} = 50,000$ pounds; very enormous pressures are therefore readily

obtained, and in consequence of the slow motion there is extremely little waste of power in friction. It is thus a very efficient mechanism. The pump can either be a hand-pump worked by a lever, L, as in sketch, or it may be worked by a steam engine, as is the case in the modern powerful presses. The enormous multiplying power of this contrivance has led to its most extensive use; for example, compressing cotton and wool bales, &c., expressing oils, bending iron plates and bars, lifting heavy weights (lifts and hoists), raising into position bridge-girders (hydraulic jacks), &c. Presses of enormous power are now superseding the huge steam-hammers in large steelworks, obviating the unpleasant vibrations and ensuring sounder metal.

Hydraulic Ram, a simple and conveniently applied mechanism, by which the energy of water falling from a height, *h*, can be made available to force a portion of itself to a greater height, *H*. There is a supply-reservoir, fed, say by a spring, from which a strong pipe, R, conducts the water to the ram at a lower level. The ram has two valves, one, A, opening downwards and inwards, the other, B, opening upwards and outwards; the weight of these valves is such that when the water is at rest its normal pressure is unable to keep them from falling, so that in this condition A would be open and B shut. A cottar on the rod of A keeps it from opening more than a certain amount, and this can be adjusted; the valve B opens into an air-vessel, C, from the bottom of which the delivery pipe, D, leads away. The action is as follows: the water flows from the reservoir through the pipe R, and rushes out through the now open valve A away to the waste-pipe; in doing so it acquires considerable velocity, and its pressure therefore on the under side of the valve A increases, and finally becomes great enough to close it. The flow of the water being thus suddenly checked, produces a great reaction, and by its momentum opens the valve B, and forces a portion of the water into the air-vessel C; the energy being expended, the pressure falls again, B closes, and A opens once more, enabling the water to rush out to the waste-pipe, and so the whole operation is repeated. The two valves thus alternately open and close, and water is delivered each time into the air-chamber, C, the air in which being compressed acts as an air-cushion, keeping up a constant delivery through the pipe D.

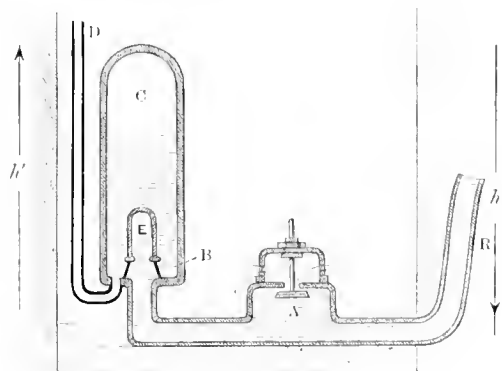

Section of Hydraulic Ram.

The small air vessel, E, is for diminishing the shocks, and has a small relief valve in it to admit air when necessary; it is self-acting. The hydraulic ram was an invention of Montgolfier (1797), but has been greatly improved; its mechanical efficiency is good, and for raising small quantities of water, such as are necessary for the supply of single houses, farm-

yards, &c.—where water at the lower level is plentiful and cheap, it is a most useful piece of mechanism. It can even be made to work a pump, and so to deliver a supply of pure water when the motive water is muddy or impure.

Hydraulics. See HYDROMECHANICS.

Hydrides. This term is applied both to combinations of hydrogen with metals, and to similar combinations with organic or compound radicals. Hydrogen forms hydrides with a number of the metals, as, for instance, arsenic, antimony, copper, and potassium. The first two of these are the well-known gases, arseniuretted hydrogen, AsH_3 , and antimonuretted hydrogen, SbH_3 . In the case of organic radicals, the hydride of ethyl, C_2H_5H , for instance, was at one time supposed to be a different substance from dimethyl, CH_3CH_3 , but these were eventually proved to be identical, so that the term hydride, in this sense, is now obsolete.

Hydrobromic Acid. (1) *gas*, HBr , invisible, pungent, acid reaction, fumes in moist air, liquid at $-69^\circ C.$, solid at $-100^\circ C.$; prepared from a bromide plus phosphoric acid, or phosphorus tribromide plus water. (2) *Aqueous solution*, analogous to commercial hydrochloric acid, is weakened by boiling until HBr sinks to 47 per cent., then distils unchanged. See BROMINE.

Hydrocarbons belong to the department of organic chemistry, and may be shortly defined as compounds of carbon and hydrogen, and nothing else. Despite their apparently simple nature, they are frequently very complex, and exist in such numbers as to bewilder the beginner in chemical study. Fortunately, they can be gathered into groups, each having distinctive characters, and the members of which are closely related to each other. The chief of these are the Paraffins, the Olefines, the Acetylenes, the Benzene (q.v.) series, and the Anthracene (q.v.) group.

The *Paraffins* are found in natural petroleum as well as in the products of the destructive distillation of coal, and are known as *saturated hydrocarbons*. By this is meant that the carbon present is already saturated (so to speak) with hydrogen, and has no tendency to unite with other elements or molecules. Graphically, carbon may be represented as C —i.e. with four arms, each one of which is capable of being united to one atom of hydrogen; and when all four arms are so united, a *paraffin* is



produced; thus, $H-C-H$. But, instead of the



single atom of hydrogen, one arm (or all the arms) may be engaged by such a group as CH_3 , so that we get another paraffin, CH_4 , CH_5 . Thus we go on forming a series, each member of which differs from the preceding one in having an extra CH_2 . Thus:

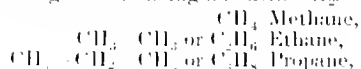

and so on indefinitely. It will, however, be noticed that when we pass to a higher member than propane, by replacing an atom of hydrogen by CH_3 , we may do so in two ways, according as the atom replaced is in the CH_3 group at either end, or the CH_2 group in the centre. The result is that two hydrocarbons are possible—viz. $CH_3-CH_2-CH_2-CH_3$, and also $\begin{array}{l} CH_3 \\ | \\ CH_2 \end{array} > CH-CH_2$. In like manner,

as we proceed further, wider scope is given to us, the result being that when Tridecane, $C_{13}H_{28}$, is reached, it is theoretically possible to recognise 802 such bodies, all having the same percentage composition, but differing more or less in characters. Many of these isomers are already known.

The paraffins are characterised by their indifference to chemical action, being unacted on by caustic potash, sulphuric or nitric acid. The general formula of the paraffins is C_nH_{2n+2} , where n represents the number of atoms in the formula.

The *Olefines*, C_nH_{2n} .—The chief of these are Ethylene, C_2H_4 , Propylene, C_3H_6 , Butylene, C_4H_8 , Amylene, C_5H_{10} , &c.; and it will be observed that in all of them the percentage composition is identical, and that each member differs from the lower one by the addition of CH_2 . When acted on by chlorine, bromine, or iodine they readily form oily liquids, such as Dutch liquid, and, generally speaking, they markedly differ from the paraffins in the readiness with which they unite with other bodies.

Hydrocele (Gr. *hydro*, 'water,' and *kèle*, 'a swelling') is a dropsy of the tunica vaginalis, the serous membrane investing the testis. It occurs as a smooth, pear-shaped swelling, painless, but sometimes causing a slight uneasiness from its weight. The quantity of fluid in the sac may amount to 40 ounces. Hydrocele may occur as a result of acute inflammation, but it most commonly comes on without any apparent local cause. It is most frequently met with about or beyond the middle period of life, and generally in persons of feeble power, or with a tendency to gout; sometimes, however, it occurs in young children, either in the same form as in adults, or as what is termed *congenital hydrocele*. The treatment may be *palliative* or *curative*. The palliative treatment consists in the use of suspensory bandages, and tapping from time to time. Tapping seldom gives more than temporary relief, the swelling usually regaining its former bulk in three or four months. The curative treatment consists in setting up inflammation in the tunica vaginalis, by the injection of tincture of iodine, so as to obliterate the cavity, or by excision of the whole or part of the sac.

Hydrocephalus. Under this term, which literally means 'water in the head,' are included three distinct diseases—viz. acute hydrocephalus, chronic hydrocephalus, and spurious hydrocephalus, or, as Dr Marshall Hall termed it, hydrocephaloid disease.

Acute Hydrocephalus, or, as it is now generally and more satisfactorily termed, *tubercular meningitis*, is essentially an inflammation of the membranes of the brain due to the presence of Tubercles (q.v.). The occurrence of fluid within the skull or the brain, though frequent, is merely a secondary and subordinate phenomenon. It is an extremely fatal form of disease, common in childhood, much less so during adult life. The symptoms are very variable and perplexing, so that only the barest outline of the most frequent and important can be attempted here. There is usually a premonitory period of some days or weeks, during which the appetite and digestion are disturbed, the disposition is altered either in the direction of listlessness or irritability, the strength impaired, and the body becomes slightly thinner. The first distinct symptom of the disease is usually severe headache, with sickness and feverishness; the pulse is rapid and the temperature raised, but variable. Vomiting very often occurs at this stage, and sometimes a peculiar cry at intervals, which if present is very characteristic.

In this first stage of hydrocephalus, which most commonly lasts two or three days, the symptoms generally are those of excitement. In the second stage the pulse becomes irregular, variable, and often slow. General heaviness and stupor come on. The light, which annoyed the child in the first stage, is no longer a source of annoyance; the pupils become dilated, the power of sight is imperfect or lost, and squinting is almost always

to be observed. The little patient now lies on his back in a drowsy condition; and at this period spasmodic twitchings, convulsions, or paralysis may appear. The exertions are passed unconsciously. The second stage may last a week or two, and is often attended by deceptive appearances of amendment, the child not infrequently regaining the use of its senses for a day or two, but then relapsing into a deeper stupor than before. The symptoms in the third or last stage, which may last only a few hours or may extend to a fortnight, are very similar to those in the second, except that the pulse again becomes very rapid, beating sometimes so quickly that it can scarcely be counted, and gradually gets more and more weak till the patient expires. The characteristic appearances after death are the presence of tubercles in the membranes of the brain, usually near the base, and generally more or less softening of the central part of the brain, with the effusion of serous fluid into the ventricles.

It must not be supposed that the stages described above can be observed in every case. There is, in fact, hardly any disease whose course is so variable and so apt to mislead those observing it. In its earlier stages its recognition is sometimes almost impossible; yet it is only then that any treatment can be expected to be successful. Cold applied to the head, leeching, and purgation sometimes appear to do good; but in the vast majority of cases the disease proves rapidly fatal. Recovery has been proved to take place only in some few exceptional instances.

Chronic Hydrocephalus is a perfectly distinct disease from that just described; while the latter is an inflammation, the former is a dropsy. In chronic hydrocephalus a watery fluid collects within the skull, before the bones have united to form the solid brain-case, and by pressure outwards causes them to separate, and increases the size of the head sometimes to an enormous extent. Thus Dr David Monro relates the case of a girl six years old whose head measured 2 feet 4 inches in circumference. While the skull is rapidly enlarging, the bones of the face grow no faster than usual, and the great disproportion of size between the head and the face is at once diagnostic of the disease. This disorder sometimes commences before birth, and almost always in early childhood, before the fontanelles and sutures of the skull have closed. In some rare cases it has occurred later, as, for example, at seven or nine years old, and the closed sutures have opened under the augmenting pressure. When the sutures will not yield, death from pressure on the brain speedily ensues. Most children with chronic hydrocephalus either recover or die in infancy; but a few survive, bearing their complaint to adult life, or even to old age. Blindness, deafness, palsy, and idiocy—one or more—are commonly associated with this disease, but occasionally the intellect and senses are sufficiently perfect for the ordinary requirements of social life.

The results of treatment are generally not encouraging, though sometimes benefit appears to result. It may be attempted by internal remedies or by surgical appliances. The medical treatment must in favour consist in the administration of diuretics, purgatives, and especially mercury, which may be given in the form of calomel in minute doses, and applied as ointment externally. The surgical expedients are bandaging and puncturing the head. The latter has in many cases certainly prolonged life, although the disease has finally conquered. Neither of these means is applicable after the bones of the skull have united.

This disease occasionally occurs in adult or

in advanced life, after enlargement of the head has become impossible. Stupor, paralysis, and an inability or unwillingness to speak are in these cases the most prominent symptoms. Dean Swift's death was due to this disease, and it is recorded that during the last three years of his life he remained in a state of silence, with few and slight exceptions.

Spurious Hydrocephalus resembles acute hydrocephalus in many of its symptoms, and has often been mistaken for it. Instead, however, of being an inflammatory disease it is a disease of debility, and is due to a deficient supply of blood to the brain. The following are, according to Watson, the distinctive characters of this spurious hydrocephalus: the pale, cool cheek; the half-shut, regardless eye; the insensible pupil; the interrupted, sighing respiration; and the state of the unclosed fontanelle. If the symptoms are those of acute hydrocephalus the surface of the fontanelle will be convex and prominent; while if they are due to spurious hydrocephalus, and originate in emptiness and want of support, the fontanelle will be concave and depressed. The remedies in this disease, which readily yields to treatment, are nourishing diet, small doses of wine or even of brandy in arrowroot, decoction of bark, ammonia, &c.

Hydrocharidea. See ANACHARIS, VALLISNERIA, WATER-SOLDIER.

Hydrochloric Acid (sym. HCl; equiv. 36.5) is one of the most important compounds in inorganic chemistry. If the two gases which enter into its composition (hydrogen and chlorine) be mixed in equal volumes they will remain without action upon each other if kept in the dark; but as soon as they are brought into direct sunlight they unite with a loud explosion, and hydrochloric acid gas is the result. The principal characters of this gas are that it is colourless, intensely acid, irrespirable, and even when largely diluted is very irritating to the lungs and eyes, and very injurious to vegetation; that it is heavier than air (its specific gravity being 1.2474, air being taken at 1.000); that it can be condensed into a colourless liquid; that it is very soluble in water, and that it is neither combustible nor a supporter of combustion. When allowed to escape into the air it produces white fumes by condensing the atmospheric moisture. If the air be previously dried no such fumes are apparent.

The solutions of this gas in water form the acid which was first known as *Spirit of Salt*, then as *Muriatic Acid*, and which is now termed *Hydrochloric* or *Chlorohydric Acid*. A saturated watery solution of this gas at 40° (4.4° C.) has a specific gravity of 1.21, and consists of 1 equivalent of the gas dissolved in 3 equivalents of water. It forms a colourless, fuming liquid, which acts as a caustic. On heating it the gas is evolved abundantly until the temperature reaches 230° (110° C.), when there distils over a diluted solution, having a specific gravity of 1.1, and consisting of 1 equivalent of the gas and 8 equivalents of water. It is to these solutions of hydrochloric acid that the term *hydrochloric acid* is far more commonly applied than to the gas itself. They possess the ordinary characters of an energetic acid, and neutralise the strongest bases. The neutralisation is, however, not in consequence of the acid combining with the oxide, but is due to the simultaneous decomposition of the acid and of the oxide, water and a metallic chloride being formed. If M represents the metal the reaction is expressed by the equation $M\text{O} + \text{HCl} = \text{MCl} + \text{H}_2\text{O}$. All metals which at a red heat decompose water also decompose this acid, and cause an evolution of hydrogen, the

reaction being expressed as follows: $M + HCl = MCl + H$. Hydrochloric acid gas is a common gaseous volcanic product. Free hydrochloric acid in a very dilute form is also a constituent of the gastric juice of man and animals, and plays an essential part in the digestive process.

Commercial *muricatic acid*—to use the name employed by manufacturing chemists—is made by heating in iron cylinders common salt (chloride of sodium) and oil of vitriol (hydrated sulphuric acid), and condensing the evolved gas in water contained in a series of stoneware Wolffian Bottles (q.v.), the reaction being explained by the equation:

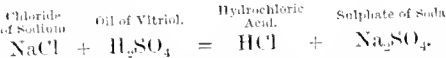

This commercial acid may contain various impurities—as, for example, iron (which gives it a bright deep yellow colour), the chlorides of sodium and arsenic—the latter being derived from the oil of vitriol—sulphuric and sulphurous acids, chlorine, &c., from which it can be purified to a great extent by dilution and redistillation. 'If pure,' says Miller, 'the acid should leave no residue when evaporated; on saturating it with ammonia it should give no precipitate of oxide of iron; sulphuretted hydrogen should produce no turbidity in it, which would be the case if arsenic, free chlorine, or sulphurous acid were present; and on dilution with three or four times its bulk of water no white cloud of sulphate of baryta should be produced by the addition of chloride of barium.' The presence of hydrochloric acid, or of the soluble chlorides in solution, may be detected by the addition of a few drops of a solution of nitrate of silver, which occasions the formation of a white curdy precipitate of chloride of silver, which is insoluble in nitric acid, but dissolves in a solution of ammonia.

Liquid hydrochloric acid (under the name of spirit of salt) was known to the alchemists. Hydrochloric acid gas was discovered by Priestley in 1772; and Davy in 1810 ascertained that it was composed of chlorine and hydrogen. In many respects hydrobromic, hydrofluoric, and hydriodic acids resemble hydrochloric acid.

Hydrocele, a Tumour (q.v.) with watery contents in the tunica vaginalis of the testes.

Hydrocyanic Acid, HCN or HCy , known also as Prussic Acid, from its having been first obtained by Scheele in 1782 from the substance known as Prussian or Berlin Blue, is of almost equal interest to the chemist, the physician, and the toxicologist.

(1) *Chemistry*.—Pure anhydrous hydrocyanic acid is a colourless, highly volatile liquid, with a specific gravity of 0.697 at 64° F. It boils at 80°, and solidifies into a crystalline mass at 5° F. It possesses a very penetrating odour, resembling that of peach-blossoms or oil of bitter almonds. It burns with a whitish flame, reddens litmus paper slightly (its acid properties being feeble), and is very soluble in water and alcohol. Pure hydrocyanic acid may be kept unchanged if excluded from light, which occasions its decomposition, and the formation of a brown substance known as paracyanogen. Hydrocyanic acid is readily obtained by distillation from the kernels of bitter almonds and many kinds of stone fruit, from the leaves and flowers of various plants, and from the juice of the tapioca plant (*Jatropha manihot*). Anhydrous hydrocyanic acid may be obtained by the action of concentrated hydrochloric acid on cyanide of mercury. The diluted hydrocyanic acid of the British and other pharmacopœias is, however, of more practical importance. It is made (*British Phar-*

mucop.) by distilling ferrocyanide of potassium with dilute sulphuric acid, and is standardised to a strength of 2 per cent. When kept for any length of time it is extremely apt to decompose.

The ordinary tests for hydrocyanic acid are (1) the peculiar odour; (2) the nitrate of silver test—there being formed a white precipitate of cyanide of silver, which is soluble in boiling nitric acid; (3) the formation of Prussian blue, by adding to the fluid under examination a solution of some proto- and per-salt of iron, by then saturating with caustic potash, and finally adding an excess of hydrochloric acid, when, if hydrocyanic acid is present, we have a characteristic blue precipitate; (4) the sulphur test, which is the best and most accurate that has yet been discovered. To the suspected liquid add ammonia and yellow sulphhydrate of ammonium; evaporate the liquid in a watch-glass to dryness, occasionally adding ammonia till the excess of sulphhydrate of ammonium is decomposed. Add water, and acidify with hydrochloric acid. If hydrocyanic acid be present the sulphocyanate of ammonium which has been formed gives a blood-red solution on the addition of a ferric salt.

(2) *Medicinal Uses*.—Diluted hydrocyanic acid is used externally as an ingredient of lotions to diminish itching in skin diseases. In 2 to 8 minim doses it is given internally to diminish irritability of the stomach, to relieve gastro-intestinal pain, vomiting, and functional palpitation of the heart. Given by the mouth or by inhalation it is also useful in allaying cough in phthisis, hooping-cough, bronchitis, &c. All these applications depend upon its action in deadening sensory nerves.

(3) *As a Poison*.—Hydrocyanic acid is one of our most energetic poisons, and is frequently employed both for murder and suicide. When a *small* poisonous dose (about half a drachm of the 2 per cent. acid) has been taken the first symptoms are weight and pain in the head, with confusion of thought, giddiness, nausea (and sometimes vomiting), a quick pulse, and loss of muscular power. If death result this is preceded by convulsions and involuntary evacuations. When a *large* dose has been taken (as from half an ounce to an ounce of the 2 per cent. acid) the symptoms may commence in a few seconds, and it is seldom that their appearance is delayed beyond one or two minutes. 'When,' says Dr A. S. Taylor, 'the patient has been seen at this period he has been perfectly insensible, the eyes fixed and glistening, the pupils dilated and unaffected by light, the limbs flaccid, the skin cold and covered with a clammy perspiration; there is convulsive respiration at long intervals, and the patient appears dead in the intermediate time; the pulse is imperceptible, and the respiration is slow, deep, gasping, and sometimes heaving or sobbing.' The patient survives for a longer or shorter period, according to the dose. According to Dr Lonsdale, death has occurred as early as the *second* and as late as the *forty-fifth* minute; the poison acts as a paralytant to the whole nervous system. Death is due to paralysis of the heart in the more rapid cases, and to paralysis of the respiration in those which occur more slowly.

Where the fatal action is so rapid antidotes are of comparatively little value. Chlorine, ammonia, cold affusion, and artificial respiration are the most important agents in the treatment. The first two should be used with great caution, and only by the medical practitioner. Cold affusion on the head, neck, and down the spine is a valuable remedy. Artificial respiration (see RESPIRATION, ARTIFICIAL) should never be omitted.

Hydrodynamics, in its complete generality, is the science which treats of the motions and equilibrium of a material system, part or all of

which is fluid. In accordance with modern dynamic nomenclature (see DYNAMICS) we should discuss it under the two headings Hydrokinetics and Hydrostatics. The historic usage of the term has, however, so fixed itself that we generally regard hydrodynamics as excluding hydrostatics and as dealing only with kinetic problems. Originally, as the derivation of the words at once show, hydrodynamics and hydrostatics referred only to the motion and equilibrium of liquids; but as our knowledge of the physical properties of all kinds of fluid, liquid and gaseous, increased, it was recognised that they had much in common from a dynamic point of view, and the terms became extended in their application as defined above. Thus the floating of a balloon in air depends on the same hydrostatic principle as the floating of a ship on water. The simpler and some of the more practical problems of hydrostatics will be found treated under that heading. In its practical engineering aspects hydrodynamics is known as hydraulics, including such important subjects as the construction of canals, breakwaters, docks, pumps, water-pipes, water-wheels, and so on, most of which have separate articles to themselves. Here we shall confine ourselves to the scientific principles of the subject, using familiar cases as illustrations.

The study of hydrodynamics has led to the conception of what is called the *perfect fluid*. It may be defined as a substance incapable of resisting the smallest deforming stress. For instance, no portion of such a fluid can resist, even for a moment, a longitudinal pressure if unsupported by a lateral pressure. The logical consequence of this definition is that, if the fluid is at rest, the pressure at a point is the same in all directions; for if it were not so there would be a deforming stress, and therefore a yielding of the fluid, and equilibrium could not exist. By similar reasoning we may show that, if the pressure varies from point to point in a fluid at rest, there must be an external force acting on the fluid in the direction in which the pressure is increasing. Thus, in virtue of gravity, atmospheric pressure decreases as we ascend, and the pressure in the ocean or any other body of water increases as we descend. So long as we are dealing with equilibrium of fluids we meet with nothing inconsistent with the definition of the ideal perfect fluid. Across every interface separating two contiguous portions of the fluid the mutual stress is of the nature of a pressure wholly normal to the interface.

When, however, we pass to cases of fluid motion we find that the properties of the perfect fluid are very far from being realised in nature. The smallest relative motion amongst the different parts of a fluid brings into play mutual stresses which are not normal to the interface between two contiguous portions. These tangential stresses tend to destroy the relative motion, existing only so long as the relative motion exists. They are thus partly analogous to resistances due to friction in the dynamics of solid bodies—hence the term fluid friction (see VISCOSITY) frequently employed to denote the property that discriminates actual fluids from the ideal perfect fluid. Fluid friction, however, differs from friction in one marked particular; it has no significance in static problems. It is wholly kinetic. The gradual stilling of troubled waters, the calming of the wind, the slackening in speed of the water in a stream as we pass from the centre and surface portions towards the banks or bottom are familiar examples of the effects of fluid friction.

Under certain circumstances the tangential stresses thus brought into play not only retard the motion of the more swiftly moving parts of the fluid, but even accelerate the motion of the more

slowly-moving parts. Thus a rapidly-flowing river entering the sea draws along with it a considerable quantity of the original ocean water. The effects of a draught of air are felt far beyond the direct course of the main current. It is impossible, in fact, to mark off clearly the boundaries of a current flowing in fluid of the same kind. In like manner, the eddies formed in the wake of a solid body moving through either air, water, or other fluid could not be produced if it were not for the existence of these tangential stresses. In every case the final result is a dissipation of energy (see ENERGY); but in the majority of cases of practical importance the rate of dissipation is so slow—in other words, the tangential stresses are so small in comparison with the other effective forces acting—that the properties of the perfect fluid go far to explain many hydrokinetic phenomena. Some of these we shall now consider.

It has been already pointed out that the equilibrium of a fluid under the action of gravity or other force depends upon the manner in which the pressure varies in the direction of the force. Now a force has always a definite direction; and consequently in all directions perpendicular to the direction of the resultant force acting at a point in the fluid there can be no variation of pressure. Thus, from any one point we can pass to an infinity of neighbouring points at which the pressure is the same; from each of these again to an infinity of others; and so on indefinitely. We thus arrive at the conception of a surface in the fluid, at every point of which the pressure is the same. Such a surface is called a surface of equal pressure, and one of its essential properties is that it is perpendicular at every point of it to the resultant force there. In the case of fluids at rest under the action of gravity these surfaces are also called level surfaces, and are for all practical purposes essentially horizontal planes. A consideration of these principles leads easily to the conclusion that equilibrium in a fluid mass cannot exist if the pressures at two points at the same level differ, or if the pressures are the same at two points at different levels. These two conditions are essentially one and the same; and when they are fulfilled, fluid motion must take place (see such articles as ATMOSPHERE, WIND, WAVE, SIPHON, and ARTESIAN WELLS for familiar illustrations of these principles).

The discharge of fluids through orifices includes a number of very important phenomena, some of which we shall discuss in detail. The vessel MAB (fig. 1) is provided at D, C, E, *a* with apertures

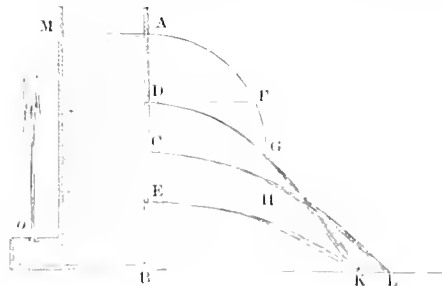

Fig. 1.

which may be closed when desired. Let the vessel be filled with water up to the level MA; then, if the orifice *a*, which looks vertically upwards, is opened, a jet of water will be projected up, and will reach very nearly to the height MA. If it were not for fluid friction and the consequent dissipation of energy the jet would reach the height MA. As soon as the orifice *a* is opened, the water

surface there being exposed simply to the pressure of the atmosphere is under the same pressure as the much higher surface MA. Hence a flow takes place and will continue to take place until the surface of the water MA has sunk to the level of the water at a . The experiment shows that the jet is projected with a velocity very nearly equal to that which would be acquired by a body falling under gravity from the level AM to the level a . This velocity is given by the relation $v^2 = 2gh$, where g is the acceleration due to gravity and h the difference of level mentioned. Similarly, if the orifices at D, C, E are opened, the issuing jets will be projected with speeds whose squares will be found to be very approximately proportional to the differences of level between the upper surface MA and the respective orifices. This may be proved experimentally by constructing the orifices so that the discharge is initially horizontal, and then measuring the range, BK or BL, reached by the several jets. Thus, assuming the law just given, commonly called the theorem of Torricelli, we may show that the square of the range BK is equal to four times the product of the differences in level of the orifice D below A and above B, that is, $4AD \cdot DB$. Hence if we describe a semicircle AGB on AB as a diameter, the horizontal lines DF, CG, EH meeting this semicircle will be half the horizontal ranges corresponding to the respective orifices.

The height of the free water surface above the orifice from which the water is issuing is technically called the *head*. The greater the head the greater is the pressure at the level of the orifice, and the more available the water for practical purposes. Part of the head is consumed in overcoming frictional resistances; for well-formed simple orifices about 6½ per cent. of the whole head is so expended. The discharge from any orifice in a given time will depend obviously on the size of the orifice and on the available head. Experiment shows, however, that for sharp edged orifices in a wall the discharge is distinctly less than the simple theory would indicate. In such cases the section of the jet is smaller than the section of the orifices in the ratio of about 5 to 8. This is sufficiently explained by the convergence of the streamlets in the fluid which ultimately form the jet; and this convergence continues for a little distance beyond the orifice, producing the phenomenon of the *vena contracta* or contracted vein. We have seen how the speed of efflux is measured by means of the parabolic path of the jet; this speed multiplied by the number of seconds in a chosen interval of time, and by the *effective* (unknown) area of the orifice gives the whole discharge in that interval. This discharge can be easily measured; and thus the data are complete for finding the effective area of the orifice and comparing it with the real area. By furnishing an orifice with a short mouthpiece of the form of the contracted vein, we may regard the smallest cross section of the mouthpiece as the true orifice. In this case the effective area and the real area are the same.

In these simple cases of efflux the energy of efflux is wholly explained as being derived from the hydrostatic head of water. The pressure due to this head is the weight of a column of water of unit cross-section and of a height equal to the head. Thus, if ρ is the density of the water, so that ρg is the weight of unit volume, the pressure p due to a head h is

ρgh . Thus, by Torricelli's theorem, $\frac{p}{\rho}$ is half the

square of the velocity with which a jet would be projected through an orifice made at a place where the pressure is p . Hence we may regard this ratio

$\frac{p}{\rho}$ as the energy per unit mass of water due to the

pressure p . But if the water is in motion with a speed v , its energy per unit-mass is on this account $\frac{1}{2}v^2$. If, further, the particular portion of the fluid considered is at a height x above a certain arbitrarily chosen level, defined as the level of zero potential energy, then its potential energy is gx . The whole energy possessed by the moving fluid is built up of these three parts due respectively to pressure, speed, and gravitation, and is given therefore by the expression $\frac{p}{\rho} + \frac{1}{2}v^2 + gx$. Now, in the case of a

steady frictionless flow along a determinate channel, the whole energy possessed by any unit-mass of the fluid must be the same; for at some time or other every element passes through the positions occupied at other times by other elements in the same streamline, and passes through them under the same dynamic conditions. Hence, neglecting the effects of friction, we arrive at the conclusion that the expression for energy just given is constant along any given stream-line. Take, for example, a pipe of uniform bore. If the flow is steady the invariableness of the cross-section requires the speed at every point to be the same. Hence as x diminishes

p must increase, so that $\left(\frac{p}{\rho} + gx\right)$ may remain constant. For a horizontal pipe x must be constant, and so of necessity is p . Now suppose the tube to be horizontal but of variable section; then, since x is constant, the expression $\left(\frac{p}{\rho} + \frac{1}{2}v^2\right)$ must also be

constant. But the speed v varies inversely as the section; hence p must be greatest where the bore is widest and least where the bore is narrowest. In other words, the cross-section and pressure increase together and diminish together. A familiar illustration of this is shown in fig. 2, in which water is escaping from a short cylindrical nozzle A. The

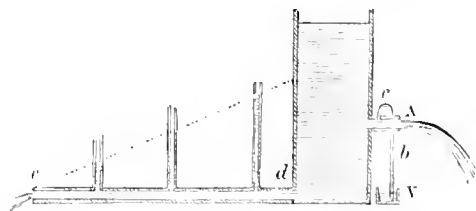

Fig. 2.

contracted vein occurs at c , so that, the velocity being greater there than at the open end of the tube, the pressure is less. But the pressure at A is the atmospheric pressure; and, consequently, if a tube be led from c to the vessel of water V, the water will be pushed up to some point b by the excess of the atmospheric pressure over the pressure at c .

When the effects due to friction are taken into account we see in a general way that the energy, instead of remaining constant as we pass along a stream-line, will steadily fall off. In the case of a uniform pipe this loss of energy will show itself in a more rapid falling away in the pressure. For instance, in a horizontal pipe of uniform bore the pressure will steadily diminish as we pass along in the direction of the flow. At the open end of the pipe (c , fig. 2) the pressure is that of the atmosphere; and this will gradually increase as we pass along the pipe against the flow until we come to d , where the pressure falls a little short of that due to the head of water in the vessel. This may be shown experimentally as indicated in the figure, in which the small upright tubes inserted in the horizontal pipe become filled with water to a certain height. In the construction of water works these and many

other problems in hydrokinetics receive their practical solution. In the motion and flow of highly compressible fluids, such as gases, we meet with theorems similar to those just discussed for liquids. The treatment, however, is necessarily more abstruse, and is far from complete if thermodynamic considerations are left out of account. See GASES, SOUND, THERMODYNAMICS.

The hydrokinetic problems connected with the motion of solids through fluids have their most important applications in questions which concern the artilleryman and the shipbuilder. In the practice of gunnery the law of the resistance to projectiles in air has been very fully worked out. At very high speeds the resistance is very great indeed; and it may be shown that an ordinary-sized projectile if dropped from an immense height (say 40 miles) could never, under the action of gravity alone, attain a speed of 800 feet per second. One great source of loss of energy of a body moving through a liquid is the formation of eddies and vortices in its wake. These are the direct result of tangential stresses acting between contiguous portions of the fluid moving with different speeds. In virtue of the same tangential stresses the eddying motions quickly die away, and the energy, as in all such transformations, takes the form of heat.

The best English treatises on hydrodynamics are Lamb's *Hydrodynamics* (1895) and Basset's *Hydrodynamics* (2 vols. 1888-89); see also Unwin's 'Hydraulics' in *Encyclopædia Britannica* (9th ed.).

Hydro-extractors. See DRYING-MACHINES.

Hydrofluoric Acid. See FLUORINE.

Hydrogen (sym. H; atom. wt. 1; Gr. *hydro*, 'water,' and *gennao*, 'to produce') is an elementary gas and the lightest substance known. It is colourless, odourless, and non-poisonous, although as ordinarily prepared it frequently contains traces of disagreeably smelling or of poisonous impurities. The gas when subjected to enormous pressure at an extremely low temperature can be reduced to the liquid state. In combination with oxygen it forms one-ninth part by weight of water, and it is a most important constituent of the tissues of animals and plants. It enters into the composition of a large number of manufactured substances and products used in the arts, medicine, &c., as, for instance, starch, sugar, vinegar, gutta-percha, alcohol, ether, benzene, aniline, indigo, morphia, &c. It is not found largely in nature in the free or uncombined state, but it does occur in some gaseous emanations from the earth, as in the solfataras of Iceland and in the petroleum regions of Pennsylvania. Being the lightest gas known, its density is often adopted as the standard of comparison for the densities of other gases. The density of atmospheric air compared with that of hydrogen as unity is nearly 14.5. As hydrogen possesses the lowest atomic weight of all the elements, the atomic weight of hydrogen is almost universally adopted by chemists as unity, and those of the other elements referred to it; but at present there is a decided movement in favour of the adoption as standard of an atomic weight which can be determined with more rigid accuracy than that of hydrogen can.

Although hydrogen is usually classed amongst the non-metallic elements, it is in its chemical behaviour more closely related to the metals. It combines with oxygen, at a red heat forming water, this combination being accompanied by the giving out of a great deal of heat. A jet of hydrogen burns in air or oxygen with a non-luminous flame, which is, however, sufficiently hot to heat to whiteness a fine platinum wire held in it. The behaviour of hydrogen towards chlorine is extremely interesting. The two gases can be mixed

in equal volumes and preserved without combination taking place for an indefinite period if kept in the dark, but on exposure to diffused daylight combination begins, and its progress depends upon the brightness of the light and the duration of the exposure. Momentary exposure to direct sunlight causes combination to take place with explosive violence, and a similar effect is produced by raising any portion of the mixture to a red heat. Hydrogen as a rule combines with those things with which the metals in general combine, forming compounds which are analogous to those of the metals. Compounds containing hydrogen and one other element are common decomposition products of decaying vegetable and animal matters; as, for instance, marsh-gas, ammonia, and sulphuretted hydrogen, which contain hydrogen combined with carbon, nitrogen, and sulphur respectively.

Hydrogen gas, under the name of combustible air, was obtained in the 16th century by Paracelsus by treating certain metals with dilute acids, and was more or less known to Boyle and others; but Cavendish (q.v.) in his paper on 'Factitious Airs,' published in the *Transactions of the Royal Society* for 1766, was the first to describe accurately the properties of this gas, and the methods of obtaining it, hence he is usually mentioned as its discoverer.

The ordinary methods for preparing and purifying hydrogen will be found in any elementary treatise on chemistry. See GASES.

Hydrogen Peroxide (sym. H₂O₂) is a compound of hydrogen and oxygen, containing a larger proportion of oxygen than water, the other compound of these elements. It was discovered in 1818 by Thénard, and was by him regarded as oxidised water as it very readily decomposes, when heated, into oxygen and water. The substance, when freed from water as completely as possible, is a thick transparent liquid, of specific gravity 1.45, without colour or smell, but possessing a bitter taste. It bleaches many vegetable colours, and when applied to the tongue or skin produces a white spot and gives rise to considerable pain. Its bleaching action and most of its chemical characters depend upon its powerfully oxidising properties. It is employed, in dilute solution, for the restoration of oil-paintings, its action upon these being an oxidising one.

Hydrography, as a branch of physical geography, deals with the waters of the globe in so far as they are available for navigation. The hydrographer determines by means of observations and soundings the outline of coasts and shores, the configuration of river-beds, lake-basins, and the seabottom adjacent to coasts, ascertains the position and extent of shoals and rocks and islands, as well as of beacons and lighthouses, investigates the nature and velocity of currents, the local tidal phenomena, the changes taking place in river-mouths and in harbours, and the alterations effected in coast-lines by the action of the sea. All these details it is his business to embody, as far as may be, in charts and maps which shall be serviceable for the practical mariner. See CHART.

Hydroid. See HYDROZOA.

Hydromechanics, a term sometimes used so as to cover what in this work is dealt with at Hydrodynamics (q.v.) and Hydrostatics (q.v.), as also hydraulics, or the department of engineering which deals with the application of liquids in motion to machinery. Hydromechanics is sometimes limited to the latter department alone. On the other hand, hydraulics is sometimes made to cover hydrodynamics. See ENGINEERING, with articles there cited, and WATER-WORKS, SEWAGE.

Hydromel, a beverage made of honey and water; fermented, it becomes mead.

Hydrometer, an instrument which indicates, by the depth to which it sinks in a liquid in which it floats, the specific density or specific gravity of that liquid. See SPECIFIC DENSITY.

Hydromys, a genus of water-mice found in Australia, Tasmania, and New Guinea, distinguished from all other rodents by the small number (27) of molars. They are called Beaver-rats in Tasmania; are nocturnal and very shy; inhabit the banks of both fresh and salt water, and swim well, with the help of partially-webbed hind-feet. The largest species is twice the size of a common rat. One species has the belly white, the other yellow.

Hydropathy, like *Hydrotherapy* and *Hydrotherapeutics*, means the use of water in the treatment of disease, or in the prevention of the tendency to disease. Popularly, however, *hydropathy* has become so attached to a special scheme of water treatment that it will be used here in that sense alone; while *hydrotherapy* will refer to the less restricted and more scientific use of water as one of the many therapeutic weapons furnished by experience to the armoury of the practitioner of medicine. Water is the world's natural medicine. We find early mention of water as a curative agent, and its virtues are extolled by many of the classical writers—e.g. Hippocrates, Galen, Celsus, Musa, and Asclepiades. In the middle ages Aetius, Alexander of Tralles, Paulus of Aegina, and Avicenna may be claimed as its advocates; while in more modern times Cudamus, Hollman, Bernardo, Sir John Floyer, Dr Baynard, the Hahn, Tissot, Dr Smith, and Hamecke deserve mention; as do also Pare, Lombard, and Percy in special reference to its use in surgery. By most of these men water was applied both externally and internally—internally chiefly as a cold drink in fevers; and it was on this point the battle raged chiefly, Boerhaave and others disputing hotly against the propriety of so administering it. To Dr James Currie (q.v.), a Liverpool physician, belongs the credit of introducing its use in fevers and febrile diseases. His book (1797) contains some most interesting information, and the records of a large number of experiments carried out to the best of his abilities, with the very imperfect thermometers then in use. His interest appears to have been originally roused by the success of Dr Wright in treating fever, both in his own case and that of others, on board ship, by the application of cold sea-water. Currie's work was translated into German by Michaelis, and spread his treatment far and wide, meeting with much favour and also with bitter hostility. Amongst its warmest supporters was Oertel, a teacher in Ansbach, who re-edited, or rewrote, many of the older treatises, and who probably had some direct influence on the man who really introduced a new era in treatment by water. This was Vincent Priesnitz (1732-1815), a Silesian farmer of Grafenberg, who after considerable success in treating wounds and sprains in animals with cold-water bandages, had to treat himself, a horse having broken some of its ribs. Again successful, he continued the treatment whenever he could on any of the neighbouring peasants, and advanced the further step of using water internally; his fame spread, and he soon gathered an immense *clientele* and achieved remarkable success. He showed great ingenuity in orienting, with the assistance of his patients, all sorts of new methods of applying water to every part of the body; and, though using water as his sole remedial agent, he very sagaciously employed hard exercise, fresh air, and a regulated plain diet as adjuncts. Unfortunately, being utterly ignorant of medicine, he taught peculiar ideas of disease, which he considered to be due to the presence in

the blood of certain acrid humours which had to be diluted and extracted by means of water. He said the escape of these produced an eruption which marked the crisis; but as it is known that water applied continuously will produce such an eruption on even the healthiest skin, and as all the known facts of pathology are opposed to his doctrines, we are obliged to reject his theories even while his practice is admitted to be admirable. It is to this special system of water treatment that the term *Hydropathy* is now generally applied. There are, however, endless hybrid varieties in which one or other theory, or particular form of practice, is either specially rejected or adopted; so it must not be supposed that the foregoing statements apply absolutely to all hydropathists. Beyond civil, however, the most scientific position to take up is that in which water is used as a remedial agent in every way, in which it has been proved to be useful, without restricting its use, or reading its results in the light of any theories, while at the same time care is taken to avoid all ill effects. This constitutes the system of *Hydrotherapy*, which obtains prominent notice in all modern books on therapeutics. Possibly the term might be improved, as heat in many cases seems to be the real agent, of which water is only the vehicle. Thermo-therapeutics and Thermo-therapy have been suggested as terms more scientifically correct. Water has often been abused, like every other good thing in this world; even an ice-water dyspepsia, due to too free indulgence in drinking iced water (but especially along with food), being not uncommon in America.

Water may be employed medicinally both internally and externally in its three forms—solid, liquid, and gaseous. For the external uses, see BATH; for its internal use with drugs in solution, see MEDICINE, and MINERAL SPRINGS. There is left for consideration here only its use internally as pure water. Absolutely necessary to the digestive process, it is essential to life, and requires rules for its advantageous use. Too large a quantity impairs digestion by so diluting the gastric and intestinal juices as to render them comparatively inert. The difficulty is to lay down definite rules for the right quantity, as this will vary with each individual in different surrounding circumstances, of temperature, amount of exercise, and quality and quantity of food. Personal experience and skilled advice must decide the quantity in each case.

As a general rule it is better to drink water about an hour before meals, as the gastric juice is then being prepared, and fluid will be thus supplied when most required. Every one with a weak digestion ought certainly to do this, and only drink a little *hot* water with food, as the stomach requires a considerable temperature to allow its physico-chemical reactions to be carried on successfully. Water is also very useful early in the morning and late at night as helping to flush out the stomach and bowels, dissolving and carrying off the waste materials which may have accumulated by the kidneys, lungs, and skin, the functional activity of which organs it much promotes. Where the evacuating power of the lower bowel is weak, or when piles are present, large injections of water, hot or cold as judged proper, are useful in clearing out the rectum and stimulating its coat. Ice internally or externally is very useful in checking hemorrhage and soothing irritability, as shown by vomiting or otherwise. As steam water is very useful in all forms of inflammation and irritation about the mouth, throat, or lungs, and often in such cases medication with various drugs increases its powers.

There are fifty hydropathic establishments in England, fifteen in Scotland, and only one in

Ireland. Most of these originally started with a full equipment for treatment, including a resident physician, bath attendants, and a complete set of baths; but many of the establishments now are merely high-class country boarding-houses. In a few, however, the hydropathist can still find all the usual requisites for correct hydropathic treatment. Amongst the best known of the old-fashioned houses are Smedley's at Matlock Bridge, Ben Rhydding, Hkley Wells House, Malvern, and Southport in England; Cluny Hill near Forres, Bridge of Allan, Melrose, Rothesay, and Crieff in Scotland; and St Ann's Hill near Cork, in Ireland. Among the magnificent modern establishments we may name those at Bath, Bournemouth, Buxton, Harrogate, Clverston, Windermere, The Hall at Bushey near Watford, Moffat, Peebles, Pitlochry, Shandon, Dunblane, Craiglockhart near Edinburgh.

See Claridge, *Old Water Cure* (1841); Graham, *Griffenberg* (1843); works on the Water Cure by Gully (1842-63), Johnson (1843), East (1850), Dunlop (1873), Smedley (1879), Braam (Eng. trans. 1875), and in German by Munde (1877), Runge (1879), Anjel (1886), with other works cited in the thirty pages of bibliography appended to Dr Winternitz's article on 'Hydrotherapeutics' in Von Ziemssen's *Handbook of General Therapeutics* (vol. v. 1886).

Hydrophis. See SEA-SNAKE.

Hydrophobia (Gr. *hydro*, 'water,' and *phobos*, 'fear') is a symptom of a disease known as Rabies, which may occur in man and in various animals; but the word hydrophobia is also frequently used to denote the disease itself. It has long been known that rabies is communicated from one animal to another if the saliva of the one is introduced into the organism of the second; whether it be the case that the first has bit the second, or has only licked it on an open sore. The saliva of a rabid animal produces no injurious effect if brought in contact with the unbroken skin of an animal, or even with a mucous surface, provided it be not exoriated. The dog is the animal most frequently affected by rabies.

When a rabid dog bites another animal the latter shows no immediate symptoms of disease. The wound caused by the teeth of the dog behaves like an ordinary wound and becomes cicatrised in the same manner. After the lapse of a certain period, which may vary from nine or ten days to several months (cases are known where the time has been as long as twenty-six or twenty-eight months), but is generally from four to six weeks, the animal that was bitten exhibits special symptoms; rabies has declared itself. The time that has lapsed since the bite was received is called the period of incubation. When the affected animal is a man, the first symptom is usually a change of character; he becomes melancholy and distrustful. Next, generally at the beginning of the case, appears a symptom called *aphobia*—the slightest breath of wind which touches the skin of the face causes its muscles to contract. Next comes hydrophobia—if the sufferer is offered anything to drink, his throat contracts, and he suffers spasms of the pharynx. When this symptom appears the death of the sufferer is at hand, and is certain to occur in two or three days. During the interval between the appearance of the hydrophobic symptoms and death the patient has periods of calm and accessions of fury, and also exhibits paralytic symptoms which usually commence in the lower limbs.

Rabies is therefore communicated by biting from one animal to another; any scratch made by the teeth of the affected animal is harmless unless the saliva is conveyed to the wound. The animals liable to be affected by rabies are very numerous,

and comprise almost all the mammalia—men, dogs, cats, horses, cattle, sheep, wolves, foxes, deer, &c.

The question of the etiology of rabies has remained very obscure until a very recent date; the most contradictory opinions were current when M. Pasteur in 1880 set himself to study this malady. His labours justify the following statements:

Rabies is a virulent disease, transmissible from one animal to another by the inoculation into the latter of those various secretions and tissues of the affected animal in which the virus dwells. This virus consists of a living organism which has not yet been made visible, by reason of the insufficiency of microscopic apparatus, but its existence can nevertheless not be denied. This statement, taken in connection with the results of M. Pasteur's labours in regard to the impossibility of Spontaneous Generation (q.v.), utterly contradicts the assertions of those who pretend to have observed rabies in animals which have never come into contact with rabid animals. Such assertions are always based on incomplete observations. If rabies could arise spontaneously in dogs, how can we explain the fact that vast regions like Australia may be wholly exempt from this scourge in spite of the great number of dogs there? The reason is that in these countries they most energetically prevent the introduction of any dog that can be suspected of rabies. If there were conditions under which rabies might spontaneously appear in dogs, then in territories so vast as the Australian colonies these conditions would certainly be realised from time to time. But there is no rabies in Australia.

M. Pasteur has studied the distribution of the virus in the individuals affected. He has observed that the virus was found in the nervous system and in the saliva, but not in the blood, the lymph, &c. Hence, if we inoculate another animal with the blood of a rabid beast, the first will remain wholly free of any rabid infection. Similarly, rabid virus introduced directly into the circulatory system of an animal will not produce rabies. But there is a sure means of communicating rabies from one animal to another—viz. by the introduction under the dura mater, on the surface of the brain, of a liquid which has first been sterilised and in which thereafter there has been soaked a portion of the central nervous system of the rabid animal. By this operation one is absolutely certain to communicate rabies unless the animal is refractory to rabies and cannot take the disease. In the course of his studies M. Pasteur observed that, in certain groups of animals which had been inoculated beneath the skin with large quantities of rabie virus, some not only did not take rabies, but became incapable of taking it—i.e. they might with impunity be inoculated on the surface of the brain with rabie virus. This observation was the origin of the discovery of preventive inoculation—of inoculation which renders an animal refractory to rabies.

The principle of such inoculation is as follows: The spinal cord of a rabbit which has died of rabies, when extracted from the body of the creature, and preserved in dry air at a constant temperature of 23° to 24° C. (74° to 76° F.), loses by slow degrees its virulence. With a spinal cord which has been so preserved for fourteen days it is impossible to communicate rabies to a rabbit or a dog. But this spinal cord has nevertheless still a certain power to confer immunity from the disease—the inoculation of an animal with a sufficient quantity of it will render it refractory to rabies. At the same time M. Pasteur observed that the freshest spinal marrows, that is to say, the most virulent, are those best fitted to confer immunity from infection. To render an animal refractory to infection the treatment commences by inoculating it with spinal cord fourteen days old, then with that of thirteen days, and so

on till spinal matter three days old is reached, two days, one day, and even such as is not yet one day old. The last may be introduced into the subject of experiment without danger, because it is already refractory.

What gives this discovery an enormous value is that these preventive inoculations made on an animal early enough and swiftly enough *after* it has been bitten prevent rabies from declaring itself. This is explicable on the following grounds: The virus is deposited by the dog's bite in a superficial wound; there it meets with little nerve-filaments in which it is further cultivated, and by means of which it ascends, somewhat slowly, to the nervous centres. These nerve-centres are the quicker affected the nearer to them the bite has been inflicted: hence bites on the head produce rabies after a shorter period of incubation than bites on the extremities of the body. If there is time to render the organism refractory by means of the preventive inoculations before the nerve-centres are affected the victim is saved; the nerve-centres once affected and destroyed, it is evident that no power of man can bring about a cure.

What ought to be done when any one is bitten by a mad dog is this. The wound made by the dog's teeth should be cauterised as soon as possible, and deeply too, so that if possible the virus may be destroyed before it has begun to cultivate itself in the nervous system. Then, if it is certain that the animal which inflicted the bite is mad, or if there is good reason so to believe, the victim should be sent as speedily as practicable to the nearest 'Anti-rabies Institute.' It is obvious that his safety depends on the quickness with which this is done. It is also obvious that bites on the head are more serious than bites on the limbs, inasmuch as there is a shorter distance to be traversed ere the nerve-centres are reached.

How can one make sure that the biting dog is mad? If possible the dog should be kept under observation without being killed; for it is much easier to recognise rabies in a living animal than by the earliest post-mortem examination. The animal will change its character, will often cease to eat, will bite everything within its reach, and will sometimes show signs of paralysis, its hind-quarters and its lower jaw being first attacked. In such cases the animal will inevitably die in from three to four days, or at most in eight days. A post-mortem examination will show the stomach empty of food, and containing on the contrary foreign substances such as bits of wood, stones, straw, &c. The most certain way of discovering if a dog was really mad is to introduce by way of inoculation a portion of its medulla under the dura mater of a rabbit. The rabbit will inevitably become rabid if the dog was rabid, but this will not take place till after fifteen or eighteen days; so that it would be imprudent for a person who had been bitten to await the result of the experiment before beginning to undergo preventive inoculation.

Statistics of the proportion of deaths by hydrophobia had never been properly kept up to the time of M. Pasteur's work in this department. Few doctors actually knew this terrible malady. It is generally said that of a hundred persons bitten by mad dogs some nineteen or twenty die of hydrophobia. This figure is probably too low. The mortality amongst cases treated at the Pasteur Institute (established by him in Paris in 1886) has fallen to less than $\frac{1}{2}$ per cent.

[So far M. Pasteur has sketched his discoveries and practice in regard to rabies, but a brief unargumentative review of current adverse criticism is also requisite. (1) As a working hypothesis, Pasteur assumes the occurrence of a specific microbe of rabies, which (in spite of various sanguine in-

vestigators) has not yet been demonstrated. In default of this demonstration, it seems to many that both the practice and the theory of rabie inoculation lack security and conclusiveness. (2) Again, there are some who, while believing vaccination to be empirically justified, are dissatisfied with the warrant for the anti-rabies treatment. They urge the acknowledged divergence between the two methods, and criticise the principle on which Pasteur works. (3) As to the warrant furnished by Pasteur's results, it is argued that the statistics are unreliable—e.g. because many of the patients inoculated were probably never infected, because in genuine cases the prevention may have been due to preliminary cauterising and to factors apart from the anti-rabies inoculation, and for various other reasons which forcibly suggest that in drawing inferences from statistics the sources of error are indeed numerous. (4) Less useful criticism is that which emphasises what is often true of progressive medical investigation—namely, that there have been failures in Pasteur's treatment, that certain tentative measures were confessedly futile, that there have been striking changes of method, and so on. (5) More serious is the allegation that some deaths have occurred as the result of the inoculations rather than of the infection from the rabid animal. Of such not altogether unprecedented casualties the possibility, but not the actual occurrence, was admitted by the English Investigation Committee (1887), while Dr Armand Leffler, who speaks with much authority, denies (1889) with all deliberateness that there is any case on record in which it can be proved that death has followed as the result of Pasteur's treatment. (6) The anti-vaccinationists have urged against certain implications of Pasteur's procedure various considerations which merit careful discussion, though without special bearing on the present problem. (7) So, too, the thorough-going anti-vaccinationists are of course among the critics of Pasteur, but their arguments can best be dealt with in connection with vaccine inoculation, about which we know at least a little more than we do in regard to the anti-rabies preventive (see VACCINATION). (8) Though there is much to be said on both sides, those who are willing to leave the problem to the experts will believe ineantine that Sir James Paget, T. Lauder Brunton, George Fleming, Sir Joseph Lister, Richard Quain, Sir Henry E. Roscoe, J. Burdon Sanderson, and Victor Horsley had good reasons for saying in the Report which they presented to parliament in 1887: 'It may, hence, be deemed certain that M. Pasteur has discovered a method of protection from rabies comparable with that which vaccination affords against infection from smallpox.'

In 1889 a Mansion House Fund was raised in London to enable poor English sufferers to be taken to the Institute; but like every other recognition of Pasteur's method, the scheme was reviewed with keen hostility by anti-vaccinationists and anti-vaccinators. In 1896 Dr Paul Gibier, a pupil and assistant of M. Pasteur, opened a Pasteur Institute in New York.

See Report of a Committee on M. Pasteur's Treatment of Hydrophobia, presented to parliament, 1887. For good summaries of Pasteur's method, see Dr E. Roux, Croonian Lecture, *Proc. Roy. Soc.* xlvii, (May 1889); Dr A. Kuller, *Brit. Med. Jour.*, (September 1889); Vignat, *Brit. Med. Jour.*, (April, May, 1886). See also papers by Pasteur in *Comptes Rendus Acad. Paris*, in *Bulletin de l'Acad. de Med.* (from 1881 onwards), in the *Annales de l'Institut Pasteur*, and in the *Ann. Révues* (X number 1889). See also Louis Pasteur, *his Life and Labours*, by his son-in-law (trans. by Lady Glad Hamerton, Lond. 1885). Of works published before Pasteur's discoveries, it must suffice to mention that of Channing. For criticisms of Pasteur, reference may be

made to publications of the Anti-Vivisection societies (especially Victoria Street, London), to papers by Dr A. Lutaud in the *Journal de Médecine de Paris*; Dr T. M. Dolan, *M. Pasteur and his Methods: a Critical Analysis* (Lond. 1886); Dr C. W. Dulles, *Medical Record* (New York, 1886); Dr M. Biggs, *The Medical News* (Philadelphia, 1886).

Hydrophyllaceæ, a natural order of herbs and bushes, containing about eighty known species, natives chiefly of the colder parts of America. None of them are of importance; but some of them are favourite ornaments of flower-borders, particularly different species of *Nemophila*.

Hydrostatics treats of the equilibrium of liquids, and of their pressures on the walls of vessels containing them. It is a purely dynamic science, and concerns itself virtually with only two of the many physical properties of liquids. These are density and mobility. In virtue of the latter property, a liquid has no tendency to conserve its shape, so that if a distorting force acts on it it yields without any tendency to recover. It has no Elasticity (q.v.) of form. Viscosity (q.v.) may retard the rate at which the distorting force takes effect; but a liquid will continue to change form so long as there is a force acting on it which is not balanced by a perfect reaction. Thus, in hydrostatic problems, nothing of the nature of a distorting force is taken into consideration. All pressures acting on portions of the liquid must therefore be perpendicular to the surfaces on which they act; and equilibrium requires equality of pressure in all directions at any point.

The fundamental property may be thus stated: When a pressure is exerted on any part of the boundary of a liquid at rest, that pressure is transmitted undiminished to all parts of the mass and in all directions. Most of the other propositions of hydrostatics are only different forms or direct consequences of this truth, which may be proved experimentally. Suppose a close box B to be filled with water, and to have inserted into the upper cover a tube *a*, with closely-fitting plug or piston, 1 square inch in area. If the

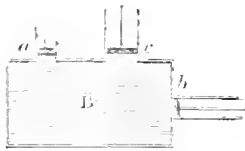

Fig. 1.

plug *a* is now pressed down upon the water with a force equal to a pound weight, the water, being unable to escape, will react upon the piston with the same force; but it obviously will not press more against *a* than against any other part of the box, therefore every square inch of the interior surface of the box is pressed outward with the force of a pound. If, then, there is another tube inserted in any part of the box with a plug of the same area, as at *b*, it will require a force of a pound to keep this plug in its place. (We leave out of account at present the pressure upon *b* arising from the weight of the water in the box above it—i.e. we neglect gravity and consider only the pressure propagated by the forcing down of the plug *a*.) However many plugs of the same size there may be, each will be pressed out with the same force of a pound; and if there be a large plug of four times the area, as at *c*, it will be pressed out with a force of four pounds. We have only, then, to enlarge the area of the piston *c* to obtain any multiplication of the force exerted at *a*. If the area of *c* is 1000 square inches, that of *a* being 1 square inch, a pressure of one pound on *a* becomes a pressure of 1000 pounds on *c*; and if we make the pressure on *a* one ton, that on *c* will be 1000 tons. This seemingly wonderful multiplication of power has received the name of the

hydrostatic paradox. It is, however, nothing more than what takes place in the lever, when one pound on the long arm is made to balance 100 pounds on the short arm.

If the pressure supposed to be exerted on the piston *a* arise from a pound of water poured into the tube above it, it will continue the same though the piston be removed. The pound of water in the tube is then pressing with its whole weight on every square inch of the inner surface of the box—downwards, sideways, and upwards. The apparatus called the *hydrostatic bellows* acts on this principle (see fig. 2). It consists of two stout circular boards connected together by leather in the manner of a bellows, B. The tube A is connected with the interior; and a person standing on the upper board, and pouring water into the tube, may lift himself up. If the area of the upper board is 1000 times that of the tube, an ounce of water in the tube will support 1000 ounces at W. It is on the same principle that the Hydraulic Press (q.v.) depends.



Fig. 2.

(1) *Equilibrium of Liquids*.—After this explanation of the fundamental properties of liquids it may be enough to state the two conditions of fluid equilibrium which directly flow from it. (1) Every particle of the liquid must be solicited by equal and contrary pressures in every direction; otherwise there would be a tendency to motion, and therefore motion because of the liquid property of mobility. (2) The upper particles at the free liquid surface must form a surface perpendicular to the impressed force. The truth of this is experimentally demonstrated by the horizontality of the surface of a liquid at rest under gravity. It can be shown to be a consequence of the primary property of 'pressing equally in all directions,' for let *da* and *cb* be vertical lines, or lines in the direction of gravity; and *ab* a plane at right angles to that direction, or horizontal. A particle of the liquid at *a* is pressed by the column of particles above it from *a* to *d*; and the like is the case at *b*. Now, since the liquid is at rest, these pressures must be equal; for if the pressure at *b*, for instance, were greater than

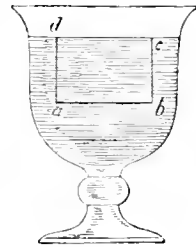

Fig. 3.

at *a*, there would be a flow of the water from *a* towards *b*. It follows that the line *ad* is equal to *bc*, and hence that *dc* is parallel to *ab*, and therefore horizontal. The same might be proved of any two points in the surface; therefore the whole is in the same horizontal plane.

(2) *Pressure of Liquids on Surfaces*.—The general proposition on this point may be stated thus: The pressure of a liquid on any surface immersed in it is equal to the weight of a column of the liquid whose base is the surface pressed, and whose height is the perpendicular depth of the centre of gravity of the surface below the surface of the liquid (see CENTER OF PRESSURE). The pressure thus exerted is independent of the shape or size of the vessel or cavity containing the liquid.

(3) *Loss of weight and Flotation*.—As a consequence of the proposition regarding the pressure of liquids on surfaces it can be shown that when a solid body is immersed in a liquid its loss of weight is equal

to the weight of the displaced liquid—i.e. to the weight of an equal bulk of liquid. Thus, if a cubic foot of the liquid weighs the same as a cubic foot of the solid, the solid will appear to have lost all its weight, and will remain in the liquid wherever it is put; if a cubic foot of the liquid weighs less than a cubic foot of the solid, the solid will appear to lose part of its weight, and will sink; but if a cubic foot of the liquid weighs more than a cubic foot of the solid, the immersed solid will not only lose all its weight, but will appear to be dominated by a *negative* weight, being urged upwards to the surface of the liquid by a force equal to the difference of the weights of the displaced liquid and the solid. In this last case the solid will rise until it swims or floats on the surface of the liquid, the amount of solid immersed in this

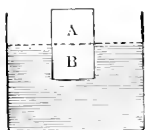

Fig. 4.

final state of equilibrium being determined by the obvious principle that a floating body must be buoyed up by a force equal to its own weight. Here again, then, the solid seems to lose all its weight, which loss must be simply the weight of the displaced water. Thus in fig. 4, where AB represents a floating solid, the water displaced by the immersed part B is equal in weight to the whole solid.

As the buoyancy of a body thus depends on the relation between its weight and the weight of an equal bulk of the liquid, the same body will be more or less buoyant, according to the density of the liquid in which it is immersed. A piece of wood that sinks a foot in water may sink barely an inch in mercury. Mercury buoys up even lead. Also a body which would sink of itself is buoyed up by attaching to it a lighter body; the bulk is thus increased without proportionally increasing the weight. This is the principle of life-preservers of all kinds. The heaviest substances may be made to float by shaping them so as to make them displace a volume of water greater than the bulk of their own solid substance immersed. A flat plate of iron sinks; the same plate, made concave like a cup or boat, floats. It may be noted that the buoyant property of liquids is independent of their depth or expanse, if there be only enough to surround the object. A few pounds of water might be made to bear up a body of a ton weight; a ship floats as high in a small dock as in the ocean.

(4) *Stability of Floating Bodies.*—Conceive *abd* (fig. 5) to be a portion of a liquid turned solid,

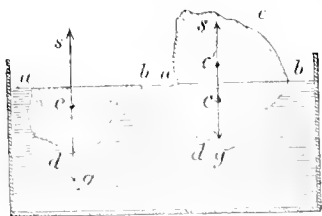

Fig. 5.

but unchanged in bulk; it will evidently remain at rest, as if it were still liquid. Its weight may be represented by the force *cg*, acting through its centre of gravity *c*; but that force is balanced by the upward pressure of the water on the different parts of the under surface; therefore, the resultant of all these elementary pressures must be a force, *cs*, exactly equal and opposite to *cg*, and acting through the same point *c*, otherwise the body would not be at rest. Now, whatever other body of the same size and shape we suppose substituted

for the mass of solid water *abd*, the supporting pressure or buoyancy of the water around it must be the same; hence we conclude that when a body is immersed in a liquid the buoyant pressure is a force equal to the weight of the liquid displaced, and acting in the vertical line through the centre of gravity of the space from which the liquid is displaced. This point may be called the *centre of buoyancy*.

We may suppose that the space *abd* is occupied by the immersed part of a floating body *abcd* (fig. 5). The supporting force, *cs*, is still the same as in the former case, and acts through *c*, the centre of gravity of the displaced water; the weight of the body must also be the same; but its point of application is now *c'*, the centre of gravity of the whole body. When the body is floating at rest or in a state of equilibrium, this point must evidently be in the same vertical line with *c*; for if the two forces were in the position of *cs*, *c'y* (fig. 6), they would tend to make the body roll over. The line passing through the centre of gravity of a floating body and the centre of gravity of the displaced water is called the *axis of flotation*.

A floating body is said to be in *stable* equilibrium when, on suffering a slight displacement, it tends to regain its original position. The conditions of stability will be understood from the accompanying figures. Fig. 7 represents a body

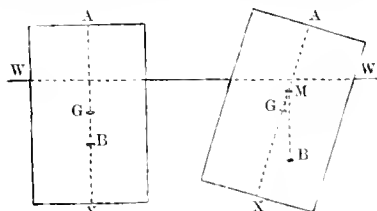

Fig. 7.

Fig. 8.

floating in equilibrium, *G* being its centre of gravity, *B* its centre of buoyancy, and *AGB* the axis of flotation, which is of course vertical. In fig. 8 the same body is represented as pushed or drawn slightly from the perpendicular. The shape of the immersed portion being now altered, the centre of buoyancy is no longer in the axis of figure, but to one side, as at *B'*. Now, it is evident, that if the line of direction of the upward pressure—i.e. a vertical line through *B'*—meets the axis above the centre of gravity, as at *M*, the tendency of the two forces is to bring the axis into its original position, and in that case the equilibrium of the body is stable. But if *BM* meet the axis below *G*, the tendency is to bring the axis further and further from the vertical, until the body get into some new position of equilibrium. There is still another case; the line of support or buoyancy may meet the axis in *G*, and then the two forces counteract one another, and the body remains in any position in which it is put; the body is then said to be in *neutral* equilibrium. In a floating cylinder of wood, for instance, *G* is always right under *B*, in whatever way the cylinder is turned. When the angles through which a floating body is made to roll are small the point *M* is nearly constant. It is called the *metacentre*; and its position may be calculated for a body of given weight and dimensions. In the construction and lading of ships it is an object to have the centre of gravity as low as possible, in order that it may be always below the metacentre. With this view, heavy materials, in the shape of ballast, are placed

in the bottom, and the heaviest portions of the cargo are stowed low in the hold. See SPECIFIC GRAVITY.

Hydrosulphuric Acid. See SULPHUR.

Hydrothorax derived from *hydro*, 'water,' and *thorax*, 'the chest' is the term applied to dropsical collections in the pleura. See DROPSY, PLEURISY.

Hydrozoa, one of the main divisions of the phylum or sub-kingdom Cœlenterata (q.v.), the other two being Ctenophora (q.v.) and Anthozoa or Actinozoa (q.v.). Two animal forms (zooïds), reducible to one common plan, are present, which often alternate in the life-history of the individual. Of one of these, the Hydroid or Polyp, the common fresh-water Hydra (q.v.), may be taken as the simplified type; the other is the Medusa or jelly-fish. It is only in this latter or in some degenerate form of it that sexual organs are produced (except in the case of Hydra). The Hydrozoa may be free

or fixed, simple or colonial, and these variations in habit, along with the existence of two kinds of zooïds just referred to, render their constitution so complex that it will be advantageous to describe briefly one or two typical forms before giving the systematic arrangement of the group.

In the case of *Sarsia* the egg produced by the jelly-fish develops first into an ovoid ciliated cellular larva (*planula*), which attaches itself to



Fig. 1.

a, *Sarsia* *fectiva* (redwood); b, branch of same (magnified 10x); c, *Sarsia* *medusa* of same, shortly after liberation. (After Allman.)

some solid object by one end, whilst the other grows into a polyp with mouth and tentacles, a colony being afterwards produced by budding. In the most essential points of its structure the Hydra may be regarded as the type of these polyps; the tentacles, however, are solid, and arranged in more than one circle; they have club-shaped ends beset with thread-cells. The name *Syncoryne* has been given to the polyps of this genus. Upon the walls of the expanded extremities appear buds, each of which, gradually enlarging and assuming the structure of a Medusa, drops off when ripe and leads an independent existence. It consists of a high bell, the mouth of which is partly closed by a circular veil attached round its margin. The clapper of the bell (*manubrium*) is long, cylindrical, and contractile, and has a mouth at its extremity leading into a stomach within its base, from which four canals radiate within the substance of the bell. At the margin of the bell they are united by a ring-canal, and beyond this they are produced into long hollow contractile tentacles. Near the origin of these from the ring canal are situated eyes, which are not merely sensitive to light, but capable of vision. A double nerve cord passes along the ring-canal, and sexual organs are developed in the wall of the manubrium. The inner and outer surfaces of the bell are covered with ectoderm, whilst the cavity of the stomach and the canals leading from it are lined with ciliated endoderm. There are ectodermal muscles in the sub-umbrella. The eggs produced by the process of sexual reproduction

develop into polyps and the whole life-circle is repeated.

In certain cases the Medusa or sexual person, instead of becoming free, has remained attached to the Hydroid polyp, and under such circumstances has undergone more or less degeneration. It may (1) present the principal structural features of a Medusa, except that it is mouthless, and that it has the form of a closed sac owing to the adhesion of the margins of the bell ('adoleoconic gonophore' of Allman), or (2) it may be merely a bud containing sexual products ('sporosac').

Aurelia aurita, one of the commonest jelly-fishes of our coasts, may be selected as an example of a Medusa of quite different structure. The bell is flattened, thickest in the centre, and notched round the margin. The manubrium is split up into four long pointed processes with fringed margins, and from the stomach and from its four sacular expansions there proceed eight unbranched canals, and eight which bifurcate several times, and are united by a marginal ring-canal. Four ring- or ear-shaped reproductive glands are developed in the base of the stomach, but hang down on the lower surface of the bell. In each of the eight marginal notches, which correspond to the main stems of the branched canals, is a so-called 'marginal corpuscle,' or sense-organ, containing an otolith and a pigment mass. These sense-organs appear to be nerve-centres, and, by their connection with a nervous plexus in the sub-umbrella, to control the movements of the animal: there is no closed nerve-ring. Between the marginal corpuscles are a large number of short tentacles. The egg gives rise to a ciliated planula, which, after swimming freely for some time, becomes fixed and gives rise to a polyp (*Scyphistoma*) which has at first four, then eight,

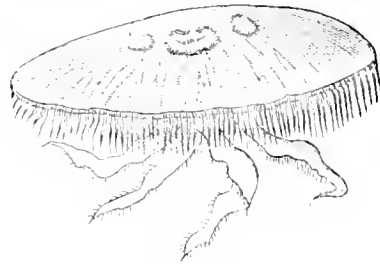

Fig. 2.—*Aurelia aurita* (reduced).

and then many tentacles. Four internal septa, reaching from the base to the margin of the mouth, divide the cavity of the polyp into a central space and four lateral recesses. Usually the polyp undergoes a series of transverse constrictions, which produce a series of Medusae, which are set free after the tentacles of the polyp have been absorbed. The organism in this stage is known as a Strobila. After a whole series of Medusae has been thus set free the polyp can form tentacles afresh, and the whole process can be repeated. The Medusae when first set free have neither arms, marginal tentacles, radial canals, nor reproductive organs, so that they have to undergo a complicated development in the free state.

The Hydrozoa are widely distributed, and all marine, with few exceptions (e.g. *Hydra*, *Caryophora*). The Hydroid polyps and colonies are attached to foreign substances, the Medusae and Siphonophora are free-swimming, in most cases near the surface, though certain forms appear to be denizens of deep water (*Pectis*, *Nauphanta*, *Rhodalia*). They are carnivorous, and some are beautifully phosphorescent (*Pelagia*, *Diphyes*). A few are fossil—e.g. the palæozoic *Graptolitidae* and

Stromatoporidae, and some Medusa from the Jurassic period, and some from the Chalk. There are about 1000 species, arranged under some 350 genera, which may be classified as follows:

1. *Craspedoia* (Hydrozoidae)—Hyroid form, either free and temporary, or free or fixed, simple or colonial, and permanent. Sometimes tentaculate, tentacles usually solid; mouth prominent, gastric cavity simple, skeleton usually chitinous, rarely calcareous. Asexual reproduction, usually by gemmation. Medusoid form, with tubular manubrium, and an inverted velum; sensory organs, ocelli, or auditory organs. It may become sessile and degenerate. Sexes separate. Almost all marine.

(1) *Trachymedusa* (Monopsea, Haplomorpha)—Free-swimming Medusa, with the gelatinous substance of the disc hard and stiff; no hydriform phase in development; tentacles primitively solid; auditory vesicles present. Examples: *Geryonia*, *Egona*.

(2) *Hydroidea*.—Hydriform person, with small polyps; generally colonial, with a chitinous (rarely calcareous) exoskeleton. Sexual only in Hydra. Medusiform person produced by gemmation from the hydriform, often degenerate. (1) Tubularia (Gymnoblastera, Anthomedusae), hydriform person usually colonial; no special receptacles for the polyps (these), or the medusiform buds (gonangia); sexual organs in the outer or oral wall of the stomach. Medusae have neither oocytes nor tentaculo-cysts, but ocelli at the bases of the tentacles; and are of the kind known as Anthomedusae. Examples: *Tubularia*, *Coryne*, *Cordyliphora*. (2) Campanularia, Caryophlastea, Leptomedusae, hydriform person in permanent colonies, with a single circle of solid tentacles; hydrothecae and gonangia usually present; medusiform persons belong to the division Leptomedusae, being flattened, having the velum feebly developed; tentacles 2, 4, 6, 8, up to several hundred, sometimes with ocelli at the base; auditory organs sometimes present; sexual glands in the radial canals. Examples: *Campanularia*, *Sertularia*, *Flombularia*. (3) Eleutherozoastera, colonies not permanent; no differentiated gonophores. Examples: *Hydra*, *Procyona*. (4) Hydrocorallia, skeleton calcareous, containing the Stylasteridae and the Milleporidae (q.v.). (5) Rhadophora, containing certain Cambrian and Silurian fossils known as Graptolites, q.v.

(ii) *Siphonophora*, Pelagic colonies, with several different kinds of modified polyps or Medusae (see special article).

II. *Acraspeda* (Acalyptra, Scyphomedusae).—Medusae, generally of considerable size, with lobed margin, bearing sensory spherules; manubrium square, usually produced into prolonged angular lappets; no velum; the sexes are separate; nervous centres in the marginal sensory bodies. Hyroid form known in but few instances; small and fixed, mouth surrounded by a disc, provided with six or more solid tentacles; multiplies by lateral buds on a creeping shoot; Medusae formed from it by transverse fission. All marine.

(1) *Tessaronia*.—Umbrella high, parts disposed in fours, four gastric pouches. (1) Stauromedusae, without sensory bodies. Example: *Lucernaria*. (2) *Promedusae*, with four sensory bodies, disposed between the principal radii. (3) *Cubomedusae*, with four sensory organs, placed in the principal radii, four simple tentacles, and eight marginal pouches. Example: *Charybdea*.

(ii) *Ephyrae* (Discomedusae). Umbrella flattened, parts disposed in eights. (1) *Rhizostoma*, no central mouth, numerous suboral apertures on eight long root-like arms; no tentacles. Example: *Cranchia*. (2) *Semostoma*, four long arms surrounding a simple cruciform mouth. Example: *Aurelia*. (3) *Cannostoma*, no arms round the mouth, which is square; tentacles solid, usually short. Example: *Nau-stome*.

In addition to text-books of Zoology in general, the following works may be consulted: Forbes, *Monograph of British Naked-eyed Medusae* (Ray Society, Lond. 1848); Agassiz, *North American Acalyptra* (Camb. U.S.A. 1865); Hincks, *British Hydroid Zoophytes* (1868); Allan, *Monograph of Gymnoblaster Hydroids* (Ray Society, 1872); *Report on the Hydroidea* (Challenger Reports, *Zoology*, parts 20 and 70, 1883 and 1888); Claus, *Untersuchungen über die Organisation und Entwicklung der Medusen* (1883); Haackel, *System der Medusen* (1879-81); *Diphysea Medusae* (Challenger Reports, *Zoology*, part 12, 1882; Lendenfeld, *The Australian Hydro-medusae* (1885) and other papers.

Hyères, a town of Provence, in the French department of Var, on a southern hill-slope, crowned by a ruined castle, 3 miles from the Mediterranean, and 13 E. of Toulon by rail. Embosomed in palm groves and orange-orchards, it is celebrated for the beauty of its situation and its mild, dry climate, and is therefore growing more and more in favour as an invalid resort between October and May. An English church was built in 1884; and since 1875 great improvements have been carried out in the way of drainage, water-works, boulevards, &c. Massillon was a native. Pop. (1872) 5881; (1891) 8347. Near the coast lie

the wooded Îles d'Hyères or d'Or (anc. *Stoechaides*). Here the heat of the climate is tempered by the sea-breezes, and the season seems an eternal spring. See Denis, *Hyères, ancienne et moderne* (4th ed. Hyères, 1882).

Hyetography. See RAIN.

Hygieia, in classical mythology the goddess of Health, was the daughter of Esculapius. She was worshipped at Athens, Corinth, Argos, and other important cities, and in works of art is usually represented as a virgin, with a snake, the symbol of health, which drinks from a cup held in her hand.

Hygiene is the name given to that department of inquiry which deals with the causes and prevention of disease in their relation to the preservation of health. As thus defined, hygiene, while it is founded on medical experience, and while it is advanced by medical research, stands out clear and defined from the ordinary run of the science and art of medicine which deal with the cure of disease. The aim of hygiene is to prevent disease by the due appreciation of the causes which induce a departure from the normal type of healthy life. In this sense it has well been named Preventive Medicine, since it seeks to anticipate the work of the physician by its endeavour to remove the causes on which the diseases that affect mankind depend. Hygiene presents for consideration two chief phases. The first section of *Personal Hygiene* relates to the individual as a unit and to his duties in the maintenance of health, and in disease prevention. The second section deals with *Public Health*, and concerns the relations which exist between masses of men and the conditions of healthy living. In the first case the study embraces such subjects as food, clothing, habits, heredity, and the like, which relate to the personal history of the unit. In the latter case hygiene has to regard the community and the nation, and to investigate the laws under which disease is liable to be propagated by the circumstances of collective life. The departments of hygiene which deal with drainage, healthy houses, the removal of waste, and the prevention of infectious disease illustrate the subjects with which the public sanitarian or health officer concerns himself. It is of importance, however, to note that, as regards these two aspects of hygiene, their scope is by no means so restricted and so limited as the terms of their definition might seem to imply. For public health, as may readily be shown, can only be advanced by the endeavours of individuals. It is the individual and personal culture of health which not only must precede, but which also forms the foundation of public sanitation.

The history of hygiene forms in itself a study of much interest, and teaches us that, like most other branches of modern science, that of health has exhibited a gradual evolution and a cumulative advance. Very far back in the history of mankind we may trace the presence of the ruling idea of hygiene, that disease could be prevented by attention to the laws and conditions of healthy living. That the hygienic codes of the Jews were remarkably full and complete is evident from a perusal of the Mosaic books of the Scriptures. These laws, dealing with questions of food and feeding, with the isolation of the sick, and with the removal from camps and dwelling places of waste matters, were of singularly enlightened character. The modern Jews have profited by the attention paid by their forefathers to questions of sanitation in the shape of their greater relative longevity, and their freedom from the scourges and plagues that have decimated the nations amidst which they dwell. The great desire of the ancient Jew

that his days might be long in the land, and that his race should grow strong and multiply exceedingly, bore a very evident relation to the practice of those health laws according to which immunity from disease is secured and longevity encouraged. So that early enough in the phases of human development and civilisation sanitary science began to be studied in view of its obvious effects upon both personal and national welfare. The Greeks may also be quoted as a nation given to make a special study of the conditions of healthy living; but in their case the culture of a high standard of physique probably included most, if not all, the points to which this ancient people paid attention. They entertained a lofty ideal of physical beauty, and attained this ideal undoubtedly through the practice of much that partook of the character of hygienic science. Apart from this bodily culture, however, the Greek was not a sanitarian in the true sense of the term. He was visited by epidemics and plagues, which were regarded as signs of displeasure on the part of his deities. He made no attempt to discover the causes of these scourges or to arrest their course. Sanitation in Greece of old was therefore more a thing of chance than of scientific nature; and of ancient Rome the same opinion may be expressed. Great public works, and most notably those connected with water-supply and drainage, were certainly undertaken and carried out on a scale of magnificence; and so far these measures must have aided in the maintenance of the public health; but plagues were frequent and loss of life excessive as in ancient Greece, and of the laws of health as we today understand that term the classic nations seem to have been nearly ignorant. Medicine itself was of course in its infancy; and for this reason—viz. the lack of knowledge of the causes or disease—the health of the ancients was largely a matter of chance.

The record of progress in health science naturally follows the course and track of ordinary history, and in this respect forms a most interesting comment on the social advance of the people. The middle ages with ourselves, for example, beheld personal health neglected and public health unknown. Cleanliness was conspicuous by its absence; the 'sanctity of dirt' was respected by priest and people alike; the houses were built closely together; their domestic appliances were of the rudest description; and drainage was non-existent. The conditions of ordinary existence were those of rapine and war, and under such circumstances it is not wonderful that the science which devotes itself to saving life should scarcely have made its influence felt at all. The clearest proofs of the utter neglect of sanitation were to be found in the fevers and plagues with the records of whose frightful mortality the story of the middle ages teems. Dr Guy, who made a special study of the history of the epidemics of the middle ages, tells us that in the 12th century no fewer than fifteen epidemics and many famines were recorded. The 13th century saw twenty plagues and nineteen famines; while the 14th beheld in its early part eight epidemics and a succession of famines. In 1348 came to England the Black Death or Great Pestilence. As the result of this plague, which attacked Europe from the East, 100,000 persons died in London alone. In Europe at large it was estimated some 25 millions of persons died from this plague. The Sweating Sickness attacked England in 1485. This was a plague which was apparently propagated within the bounds of our own land by the filthy and impure surroundings of the people. After being attacked by the sweating sickness, the victim usually died within twenty-four hours. It attacked

the well-to-do and intemperate livers especially, and appears to have been more fatal in the case of men than of women. After a succession of reappearances this epidemic passed away in 1551, and has since that date been extinct. A century or so later (in 1666) came the Great Fire of London, a catastrophe which was not an unmixed evil, since it cleared away the Old London with its foul and close houses, and induced the erection of a new and more sanitariously built city. The great fire apparently gave the *coup de grâce* to the Great Plague, which prior to 1666 had swept from time to time across the country, but disappeared in that year, happily to return no more. The cessation of the epidemic plagues thus enumerated was doubtless due to the abolition or modification of the conditions under which they had previously flourished. Less crowding together of people and of their dwellings, a freer atmosphere, and a greater measure of cleanliness doubtless acted then as now in abolishing epidemics; but even in the 18th century smallpox, typhus or jail fever, scurvy, ague, and other diseases continued to be only too well represented as legacies of the ignorant and careless living which characterised the preceding era.

It is, however, in the 18th century that hygiene begins to appear on the social horizon with something of clear outline and defined aims, as a distinct branch of science, pursuing a very practical relation to the lives of men. The Black Death and other plagues had then disappeared as we have noted, and thus the chances of prolonged life had become materially increased in Britain and in other European countries as well. The sanitary historian of the 18th century has to take account of at least three great names as those of forerunners in the work of hygienic progress. John Howard (q.v.), the philanthropist, largely based his work of jail reform on improvement in the terrible state of these places of detention. They were overcrowded, and filthy in the highest degree, and, as a consequence of these conditions, typhus fever (which is a disease of overcrowding) reigned rampant under the name of 'jail fever.' Howard by his unflinching efforts succeeded in clearing the jails of this pest; and to-day our criminals reap the fruit of Howard's philanthropy in the fact that the jail now ranks in reality as the healthiest of dwelling-places. It is no exaggeration to say that if our homes could be rendered sanitary to the same extent as are the jails of our land, the death-rate would be speedily reduced to a minimum compared with its present amount. Captain Cook, the navigator, stands out as the second of the sanitary pioneers of last century. He it was who first showed that scurvy, which is essentially a blood disorder, and from which whole ships' crews used to remain prostrate in long voyages, was due to improper feeding. In one of his voyages Anson lost 600 out of 900 men from scurvy. Cook in a three years' voyage lost only four hands out of 118, and not one of these four deaths was due to the seaman's pest. He showed that in the absence of fresh vegetables, lime-juice should be served out regularly to ships' crews (see SCURVY). To-day Captain Cook's discovery is duly acted upon in the case of long voyages; and the extinction of scurvy in this fashion may be regarded as parallel in importance to the prevention of ague through the draining of the swamps and morasses amid the decaying vegetation of which the ague germs breed and multiply.

The third discovery of importance in sanitation in the 18th century introduces us to a feature in disease prevention which demands especial notice, because of the renewed importance which the prin-

eiple in question has acquired in our own days. This feature may be called that of the *modification* of disease. It began, doubtless, far back in the history of eastern nations, if we are to credit Hindu records, but in 1720 Lady Mary Wortley Montagu, wife of the English ambassador to Turkey, introduced it to the notice of English physicians under the name of *inoculation*. This practice came into vogue as a preventive of smallpox in its pristine severity. Here smallpox matter, taken from the pustules of a person suffering from that ailment, was inoculated into the bodies of healthy persons. The result as a rule was that they acquired a mild attack of the disease, and this attack was found to prevent a future invasion of smallpox. Inoculation undoubtedly did not limit the spread of smallpox—indeed, as can be seen, it favoured its spread—but it undoubtedly tended to modify that loathsome ailment, and to prevent the dreaded scars and deformities which resulted from the disease in its full vigour. Later on came Jenner's discovery of *vaccination*. This practice began about 1796. Here matter taken from the pustules of cow-pox was used to 'vaccinate' the human being, the result being that a mild attack of cow-pox (or allied disorder) was given to children, and this was found, and still is found, in the vast majority of cases to be preventive of smallpox. The subject of vaccination need not be discussed here; reference may be made to the article on that subject; suffice it to say that since 1840, when vaccination began to be made the subject of legal enactment in Britain, and since 1853, when free vaccination was provided for the poor by law, smallpox has decreased both as regards frequency and severity. In 1867 vaccination was made compulsory for infants, and at the present time, even if it has not effected a universal escape from smallpox attack, we may congratulate ourselves upon a tremendous saving of life from this disease by its aid.

The advance of medical science—and especially the progress which has been made in microscopic research into the causes of disease—together with the spread of education, and of a consequent intelligent interest in health science among the people, has tended powerfully to awaken national endeavour in matters both of personal and public hygiene. In Britain the law has stepped in, and has provided, by means of many suitable enactments (1848, 1875, &c.), full encouragement in the pursuit of healthy life, as well as protection against health dangers. Each town or district is provided with its medical officer of health, and with its sanitary inspectors, whose duties comprehend the abolition of nuisances and the general supervision of drainage and other sanitary details. To-day it may be said that we possess a very fairly equipped staff of health experts in every large town, able and eager to assist and advise the citizens in the discharge of their manifest duties to themselves and their neighbours in the observance of hygienic rules. One of the most important enactments, for instance, is represented by the law which in many towns makes compulsory the notification to the authorities of every case of contagious disease which falls under the notice of the householder or medical attendant or both. In this way it is sought to limit the spread of those infectious ailments which add so largely to the death-rate each year. The authorities, being early informed of the appearance of any cases of these diseases, can take prompt measures for their isolation and their removal, if need be, to hospital. One case of smallpox, of typhus fever, or of scarlet fever may readily become, by neglect, the parent of thousands of cases, with a probable mortality frightful to contemplate; whereas by prompt isolation of the

first case or cases misery, pain, loss of money, and chances of death may be saved to thousands. The seaports, too, are now narrowly watched by the health officers of these ports, and suspicious cases of illness on vessels arriving in harbour are at once dealt with. Cholera, it may be mentioned, which has run unchecked on the continent of Europe on several occasions within late years, has thus been warded off from the British coasts by the active supervision of the health authorities at the ports.

Within the sphere of the home health science has made of late years satisfactory progress. The principle of safe and sanitary drainage, whereby a house can be trapped off efficiently from the public sewers, and the inroads of sewer-gas (giving rise to typhoid fever and other ailments) prevented, is beginning to be everywhere practised. Plumbers are now encouraged to undergo examinations, instituted first of all by the Plumbers' Company of London, and to acquire thereby certificates of registration showing their knowledge of the principles on which house-drainage should be constructed. The vile 'scamping' work in the matter of drains so prevalent in former years, and so fraught with danger to the inmates of houses, it is to be hoped will be effectually banished from our midst. Here, as elsewhere, in sanitary science, the intelligent interest shown by the public in hygiene is beginning to bear fruit. The householder is no longer content to leave the sanitary arrangements of his house in the hands of ignorant architects or equally ignorant plumbers. His interest in his health affairs and his demand for sound sanitary work is a species of demand for which the inevitable supply is forthcoming in the shape of the increased attention now being paid to the construction of closets, baths, drains, lavatories, &c., and to the efficient protection of the house from the inroads of drain effluvia. In other details also the health of our homes is receiving the care it deserves. Questions of ventilation and of lighting are being studied anew, and the warming of houses is no longer left to chance. Personal health, which ranges in its extent from questions of foods and drinks to those of cleanliness and clothes, is not neglected amid the general improvement in hygienic education; so that the outlook in health questions is on the whole of the most hopeful kind. Happily the people at large are beginning at length to perceive and to act on the great truth that only by their personal education in hygiene, and by their knowledge and observance of health laws, can they secure the length of days which of old it was declared Wisdom bore in her right hand.

As a final point deserving of mention in relation to the acquirement of hygienic knowledge we may refer to the spread of knowledge regarding the exact causes of those infectious or zymotic diseases to which reference has already been made. These diseases include such ailments as smallpox, typhus fever, cholera, typhoid (or enteric) fever, measles, hooping-cough, diphtheria, scarlet fever, and like disorders. That they are responsible for a very large amount of our annual mortality is a stable fact, and it is interesting to note how the better knowledge of their causation bids fair to enable us to cope successfully with their attack. It is now generally admitted that each of these diseases arises from a specific living particle or *germ* which, sown in the body, under favourable conditions, gives rise to the disease in question. Each germ is derived from a previous case of the disease, and each disease, under ordinary circumstances, breeds true—that is to say, if we sow smallpox we reap smallpox, and not measles or scarlet fever; and so with every other disease. What is known as the 'germ theory of disease' has thus come to assume a paramount

place and power in modern hygiene. Already we have become acquainted with the specific germs of many disorders. We know, for example, the *Bacillus tuberculosis*, or germ to which tubercle is due—consumption or *phthisis* being merely a form of tubercle, as that disease affects the lungs. The germ of relapsing fever is also known, and that of the splenic fever of cattle and sheep has been very fully studied. The fight of mankind against these fevers and allied ailments is thus in reality a combat with the germs to which they owe their origin. All attempts to limit these disorders by disinfection or otherwise are directed towards the destruction of the germs which are given off from each case of a given disease, and which, if allowed to escape into air or water, infallibly spread the ailment broadcast. The knowledge of the exact origin of such diseases is therefore a powerful weapon in the hands of the sanitarian. In other ways than by germ-destruction it is sought to protect man and animals against disease attack. Pasteur and others, by modifying the germs of a disease (e.g. those of splenic fever) by submitting them to varied conditions of temperature, &c., and by artificially propagating them in appropriate solutions, have succeeded in producing germs of altered and weakened power. These later, used to inoculate animals, produce a mild form of the disorder, which protects against subsequent attack (see HYDROPHOBIA). This is the latest practical development of the germ theory itself. How far it may be extended to protect man against his enemies in the shape of disease germs the future alone can tell. Meanwhile, it is interesting to reflect upon the fact that there is at least a possibility of the abolition of many of the ailments which now affect us by the combined work of attention to the ordinary laws of health and the promotion of a high standard of physical development, and, it may be also, by the work of science in fortifying us by inoculation against the invasion of our disease enemies.

It may be added that the cause and advance of sanitation in England has been encouraged and assisted by various Health Exhibitions held in London and elsewhere, in which the latest sanitary inventions and appliances were shown. One of the fruits of the London Health Exhibition of 1884 was the publication of an admirable series of hand-books, written by eminent sanitarians and physicians, and dealing with the various phases of public and personal health. As regards the advance of sanitary science abroad, Germany has long evinced a thorough appreciation of the advantages of scientific instruction in hygiene, and the Sanitary Institute at Berlin, presided over by Dr Robert Koch, is in its way a model of what such an establishment should be. Laboratories for the study of public health science have been established in connection with most of the English universities; while the Royal College of Physicians of Edinburgh and the Royal College of Surgeons of London have built laboratories specially intended for the study of germ life, and for bacteriological investigations in relation to the production of diseases at large.

In the United States the supervision of health matters is delegated to Boards of Health, of which one exists in each state. These boards receive reports from medical officers and other experts, and publish each an annual report containing much suggestive matter for the guidance of health reformers and for the improvement of the public health at large. Quarantine, conducted on rational principles, with the rigid exclusion of diseases liable to be imported by immigrants, is made a notable feature of the sanitation of the United States.

See the articles BACTERIA, BATHS, COOKING, DIET, GERM THEORY, GYMNASIUMS, HEALTH-RESORTS, HOS-

PITALS, HYDROPATHY, NURSING, MEDICINE, SEWAGE, VENTILATION, WAREHOUSES; also Parkes's *Hygiene* (1883); Galton's *Hygienic Details* (1880); G. Wilson's *Manual of Hygiene* (1886); Corfield's *Health* (1880); the present writer's *Manual of Health Science* (1885); Simon's *English Sanitary Institutions* (1890); Sir E. W. Richardson's *Diseases of Modern Life, The Common Health*, and his life of Chadwick; and books on hygiene by Stephenson and Murphy (1892-93), Willoughby (1894), and Lehmann (1893).

Hygrometer (Gr. *hygros*, 'moist,' *metron*, 'measure'), an instrument for measuring the quantity of moisture in the atmosphere. The earlier forms of hygrometer depended upon the property possessed by some substances of readily absorbing moisture from the air, and being thereby changed in dimensions or in weight. Of this kind was the hair hygrometer of Saussure, in which a hair, which expands and contracts in length according as the air is more or less moist, was made to move an index; a similar instrument was the whalebone hygrometer of Deluc; but as other causes as well as moisture affect such instruments they afford no accurate indications. The most perfect hygrometer, theoretically, is that of J. E. Daniell (q.v.). It consists of two bulbs connected by a bent tube, as represented in the figure, and enclosing a thermometer, together with some ether

and vapour of ether, the air having been expelled. The bulb *b* is covered with muslin, and *a* is either blackened or coated with metal. The observer's hand is placed for a short time on *b*, to drive the ether into *a*, leaving *b* and the tube filled with vapour of ether. A little ether is then dropped from a flask, of the form *c*, on the muslin-covered bulb; evaporation instantly takes place and produces

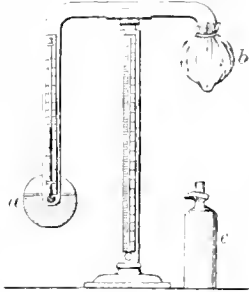

a cooling of *b*, which condenses the vapour inside; a fresh evaporation from *a* fills the vacuum, which is again condensed by dropping ether on *b*, and the process is repeated till the temperature of *a* is so reduced by successive evaporations (see EVAPORATION) that *dew* begins to be formed on the outside of the bulb. At the instant this occurs the height of the mercury in the two thermometers is accurately noted, the one giving the dew-point temperature, and the other the temperature of the air. The actual quantity of moisture contained in a cubic foot of air can now be readily found from the following empirical formula: weight of moisture in

grains = $\frac{5656 \cdot 2}{448 \cdot t} \cdot p$; where *t* is the temperature of the air at the time of observation, and *p* (found from tables) the elasticity of vapour at the temperature of the dew-point. The evident defects of this instrument are, first, its rapidity of operation, so that no time is allowed for the glass, ether, and thermometer to come to the same temperature, and in consequence the dew-point is given higher than it actually is; secondly, its costliness, owing to the great consumption of ether; and, thirdly, its uselessness in tropical countries, owing to the difficulty of preserving the ether in a fluid state. Daniell's hygrometer was used at the Royal Observatory, Greenwich, from 1840—the commencement of meteorological observations—till 1847, when it was superseded by the more convenient instrument, the Wet and Dry Bulb Thermometers. This instrument consists of two ordinary thermometers; one has its bulb bare, and this shows the temperature of the air; the other has its bulb covered with

muslin, which is kept wet by a cotton wick dipping into water. The evaporation from the muslin, and consequent cooling of the bulb, being in proportion to the dryness of the air, the difference between the readings of the two thermometers is greatest when the air is driest, and zero when it is completely saturated. The readings of the thermometers being taken, the elastic force of vapour at the dew-point is calculated by the formula of Dr Apjohn:

$$(1) F = f - \frac{d \cdot h}{88 \cdot 30}; \quad (2) F = f - \frac{d \cdot h}{96 \cdot 30};$$

the first formula to be used when the wet thermometer is above, and the second when it is below the freezing-point (32). In these formulae F is the elastic force of vapour at the dew-point, which has been determined for different temperatures by Regnault from carefully conducted experiments; f , the elastic force at the temperature of evaporation (or reading of wet bulb); d , the difference between the dry and wet bulbs; and h , the height of the barometer. From this the quantity of moisture in a cubic foot of air, &c. can be found as before. To dispense with these troublesome calculations the *Hygrometric Tables* of Mr Glaisher may be used, except in very dry states of the atmosphere, such as occasionally occur on Ben Nevis and very dry climates, when Dr Apjohn's formula must be used.

Hygroscope is a name sometimes given to an instrument for indicating the presence of moisture in the atmosphere, without measuring its amount. Hygroscopic substances are those which imbibite moisture and become coated with a moist film.

Hyksos, or SHEPHERD KINGS. See EGYPT, Vol. IV. p. 239.

Hymen, or HYMENEUS, in Greek Mythology, the god of marriage; but originally the word seems to have denoted only the bridal-song, which was sung by the companions of the bride as she went from her father's house to that of the bridegroom. The god Hymen is first mentioned by Sappho. The legends concerning his birth and descent are various; but he is generally said to be a son of Apollo and some one of the Muses. He is represented as a youth with wings, a bigger and graver Cupid, with a bridal torch and a veil in his hands.

Hymenoptera (Gr., 'membrane-winged'), an order of insects, including (*a*) ants, bees, wasps (*Aculeata*)—with stings; and, in a lower division, (*b*) gall-flies, saw-flies, and ichneumon-flies (*Terebrantia*), in which the abdomen of the female bears a boring ovipositor. The mouth parts are adapted both for biting and sucking. The wings are typically four, membranous, and with comparatively few veins; they may be caducous or absent; the second pair is always smaller than the first. The metamorphosis is complete. Both in structure and intelligence the hymenoptera occupy a high place among insects, and indeed among animals. Their characteristics will best be gathered from the study of special types. See ANT, BEE, GALL-FLY, SAW-FLY, WASP, and INSECTS.

Hymettus, a mountain (3368 feet) in Attica, now called Trelo Voumi, situated to the south-east of Athens, was famous among the ancients for its honey and its bluish marble. The honey is still in repute.

Hymn. The usually accepted definition of a Christian hymn is that of St Augustine: 'Do you know what a hymn is? It is singing with the praise of God. If you praise God and do not sing, you utter no hymn. If you sing, and praise not God, you utter no hymn. If you praise anything which does not pertain to the praise of God, though in singing you praise, you utter no hymn.' The hymns of the church which are known to us as existing at the time these words were written

(c. 415) were mainly of the character thus defined. With the spread of Christianity, however, changes took place which gave rise to another and broader meaning to the hymn. The expansion of church life and the development of doctrine and practice required that fuller liberty should be extended to sacred song. The outcome of this expansion of the original idea and form of the hymn has resulted in the accumulation of vast stores of sacred lyrics, a large proportion of which have passed from time to time into public use in divine worship. The languages and dialects represented therein number more than two hundred.

I. New Testament Hymns.—The early history of Christianity is in our Sacred Books; and to them we must go for the first examples of Christian song—the Magnificat, the Benedictus, the Angelic anthem (see DOXOLOGY), and the *Nunc Dimittis*. The fourfold record of our Lord's ministry contains no other songs. In the Acts of the Apostles we read of hymns being sung; but of their structure and contents we have no example. On turning to the epistles of St Paul, St James, and St Peter, we have some indications of the nature of the hymns which were then sung. Fragments of what, to every appearance, were familiar hymns in the early church are found therein, some of which are known as the 'faithful sayings' of Holy Writ. These include 'Awake thou that sleepest,' &c., Eph. v. 14; 'If we die with Him, we shall also live with Him,' &c., 2 Tim. ii. 11, 12; 'Manifest in the flesh, justified in the spirit,' &c., 1 Tim. iii. 16; and others, as 1 Tim. vi. 15, 16, Titus, iii. 4, 7, and James, i. 17. The songs which St John heard in vision, although true lyrics, cannot be classed as early Christian hymns.

H. Greek.—(1) In Greek, the mother tongue of Christianity, it is natural for us, when we have closed the Sacred Record, to search for the earliest forms of sacred song. In the Ante-Nicene period we have a few only, some of which are written in the classical metres, and others which are 'more oriental in character, and have an affinity to the Hebrew modes.'

Of the former the best-known instance is that of Clement of Alexandria (died 220?), translated by Dr Dexter as 'Shepherd of tender youth.' Although Clement's authorship is not beyond doubt, yet it is essentially a hymn of his day, and is absolutely confined, in its subject-matter, to the incidents and doctrines of Holy Writ. The hymns and poems of Gregory of Nazianzus (330-389) are all in classical measures. They were probably written after 381, and number about 240 in all, of which 38 are dogmatic, 43 are on moral subjects, 99 relate to his own life, and 60 more are on miscellaneous subjects. Although amongst these sacred pieces there are several splendid hymns, we know not one in a modern hymn-book. Some of the finest are easily attainable in the original in Christ and Parakkas's *Anthologia Græca Cœciliæ Christianorum* (1871), and in a translated form in A. W. Chatfield's *Songs and Hymns of the earliest Greek Christian Poets* (1876). Another writer in the classical metres was Synesius (375-450). He was an eloquent bishop, and well read in the philosophy of his own and of older days. His ten hymns are also printed in the *Anthologia Græca*, and translated by Mr Chatfield and by Alan Stevenson (1865). One of these hymns, translated by Mr Chatfield as 'Lord Jesu, think on me,' is given in a few modern hymnals. 'Though of great spirit, reality, and beauty,' the hymns of Synesius be confessedly on the borderland of Christianity and Neoplatonism, and often it is the Platonic rather than the specially Christian thought that inspires his most refined passages' (*Dict. of Hymnology*, p. 457). The hymns of Sophronius, patriarch of Jerusalem (620), are of a still later date, as are also those of Elias Synellus and St John of Damascus. Of these hymns in the classical measures none, except three canons of St John of Damascus, were incorporated in the services of the Eastern Church.

(2) The link of connection between the Jewish

and the Christian hymnody is found not only in the use which was made from the very first of the Jewish Psalter in Christian worship, but also in the adoption of the ancient 'Hallelujah' and 'Hosanna,' and in the alphabetical and other forms of Christian antiphons and versicles. The primitive Greek hymns, as distinct from hymns of the New Testament on the one hand, and the sacred poems in classical metres on the other, were largely derived from Holy Scripture.

The *Te Sanctus* is an expansion of Isaiah, vi. 3, and usually reads 'Holy, holy, holy, Lord of Sabaoth; Heaven and earth are full of His glory. Blessed art Thou for ever. Amen.' The germ of the *Gloria in Excelsis* is the Anglican song at Bethlehem. The Greek form of the *Gloria Patri* ('Glory be to the Father,' &c.) seems to have had its origin in Our Lord's commission, 'Go ye therefore . . . baptising them in the name of the Father, and of the Son, and of the Holy Ghost.' Besides these, the *Trisagion*, 'Holy God, Holy and Mighty. Holy and Immortal, have mercy upon us;' the *Cherubic Hymn* of the Greek liturgies, 'Let us who mystically represent the Cherubim, and sing the holy hymn to the quickening Trinity, lay by at this time all worldly cares, that we may receive the King of Glory, invisibly attended by the angelic orders, Alleluia, Alleluia, Alleluia;' the hymn of Justinian, 'Only-begotten Son and Word of God,' &c.; and various clauses in the *Te Deum* are all based upon separate or accumulated passages of Holy Scripture.

There are also the hymn at lamp-lighting, widely known through Keble's translation, 'Hail! gladdening Light,' which was old in St Basil's time (370); 'The Virgin's Song' of Methodius (died c. 311), translated by Mr Chatfield as 'The Bridgroom cometh!' but not in liturgical use in ancient or modern times; and a few others. Early Greek hymns are few in number but of fine quality, and deal almost exclusively with scriptural subjects.

(3) The liturgical use of hymns in the church's infancy does not seem to have been extensive. Both Pliny and Justin Martyr bear testimony to their use in public worship, and we know that some were in use in the church of Antioch in 260. 'Yet as late as the 4th and 5th centuries there was a scruple against the use of anything but psalms in the eastern monasteries, and in Spain the Council of Braga (561) forbade the use of hymns' (*Dict. of Hymnol.* p. 460). Ultimately, however, the popularity and power of hymns became so marked through their use by the heretics, and their employment as a counter-check by the faithful, that their exclusion from divine worship became no longer possible. The change was on a limited scale at first, but after the complete separation of the Eastern from the Western Church the hymn in its various forms gradually assumed a prominent and permanent position in the Greek liturgy.

(4) It has been pointed out that the principal link between the early and later hymns is found in a group of pieces discovered by Cardinal Pitra in two rare liturgical MSS. at Moscow and Rome (Cardinal Pitra's *Amalthea Sacra Inedita*, Paris, 1876).

(5) The next period (600-900) is that in which we have the building up of those elaborate service-books of the Greek Church, known to us as the *Menaia*, the *Genaria Octoechus*, the *Lesser Octoechus*, the *Triodion*, the *Pentecostarian*, the *Exocholouan*, and the *Hodegion*. In these works the number and variety of hymns are very numerous. The hymn-writers of this period were associated at first with Jerusalem and other parts of the Holy Land, and subsequently with Constantinople.

(a) The *first group* includes St Andrew, Archbishop of Crete (600-c. 732), who is known as the author of several canons, triodia, and idiomela, including the great canon of the Mid Lent week. To the English reader he is best known through the cento, made by Dr Neale, 'Christian, dost thou see them?' Almost

contemporary with him was St Cosmas, a monk of St Sabas, near Jerusalem, and afterwards Bishop of Maiuma, near Gaza, who died c. 760. He was the author of several pieces, including a canon for Christmas Day, beginning in Dr Neale's translation, 'Christ is born! tell forth His fame.' At St Sabas with Cosmas was John of Damascus, who became a tower of strength in Greek hymnody. Born at Damascus, he accompanied his foster-brother, Cosmas, to St Sabas, and there he wrote his theological works and his hymns. Late in life he entered the priesthood, and died at a great age (c. 780). His influence upon later Greek hymnody was very great. He arranged the *Octoechus* in accordance with the Eight Tones, and supplied it with several canons of great merit. His canons are his finest work, that for Easter (beginning in Dr Neale's translation, 'Tis the day of Resurrection') being well known, in part at least, to the English reader. Within the next fifty years St Theophanes, a native of Jerusalem, also of St Sabas, and afterwards Archbishop of Mida, was writing extensively on the martyrs and confessors of the Greek Calendar, which took the form of canons and idiomela. Although largely represented in the *Menaia*, he is almost unknown to the English reader.

(b) The *second group* of hymn-writers were associated with Constantinople. The first of these is Joseph the Hymnographer (died 833), a native of Sicily, but afterwards founder of a monastery at Constantinople. He was one of the most voluminous of the Greek poets, and is largely represented amongst the canons in the *Menaia*. His canon for Ascension Day is very fine. Of it, however, but a small portion is familiar to English readers. Ode iv., translated by Dr Neale as 'Jesus, Lord of life eternal,' being the best known. 'Let our choir now anthems raise,' and 'Stars of the morning so gloriously bright,' are also translations by Dr Neale from St Joseph. St Joseph of the Studium, sometime Bishop of Thessalonica, wrote several pieces; but none of them have been translated into English. His elder brother, St Theodore of the Studium (died 826), wrote several canons, notably that on the Judgment, translated by Dr Neale as 'That fearful day, that day of speechless dread,' and regarded by Neale as 'undoubtedly the grandest judgment-hymn of the church previous to the *Dos Ica*.' He also wrote 'A song, a song of gladness,' which is a part of his triumphal canon on the victory of the Icons. Methodius II. (died 836) also belongs to this group of poets. Of the few pieces which he wrote, Dr Neale has translated one only, 'Are thy toils and woes increasing?' and has given it as by St Methodius I. in error. Theoctistus of the Studium (c. 890), said by Dr Neale to have been a friend of St Joseph's, is not largely represented in Greek hymnody. He is known to English readers through Dr Neale's translation of a cento from his 'Suppliant Canon to Jesus,' as 'Jesus, Name all Names above,' and the Rev. R. M. Moorson's rendering of the same, 'Sweet Saviour, in Thy pitying grace.'

(6) From this date to the 16th century, when the Greek service-books were practically closed against new compositions, very few names are known. We have Metrophanes (died 910); Euthymius (died 910); Constantine Porphyrogenitus (913-959); Leo VI. (died 917); John Mauropus (died 1060); and Philotheus, Patriarch of Constantinople (died 1376); but only one or two pieces by these writers have been rendered into English.

III. *Syriac* (170-1370).—Syriac hymnody deals with the churches of Syria, Upper Mesopotamia, and western Persia. Its history extends from the 2d to the 14th century.

The earliest known hymn-writer in this language is Bar-Daisan (Bardesanes, q.v.), born in 151. His son Harmonius was also a hymn-writer. Both father and son had Gnostic tendencies. On the orthodox side we have Simeon bar Sabbae, Bishop of Seleucia, who suffered martyrdom in 296; and the greatest of all, Ephraem Syrus (q.v.; c. 306-378). His poetical writings were numerous, and included homilies, discourses on Christ's Nativity, the Creation, and other subjects. Most of the Syriac hymns and hymnists are practically unknown to the western world. In the East, however, these hymns form a considerable portion of the service-books of the various divisions of the Syriac churches to the present

day. Their English use is very limited. The best-known example is 'Glad sight, the holy Church,' by the Rev. F. Pott.

IV. *Latin*.—(1) No name is associated with Latin hymns until after the Council of Nicea, 325. Almost immediately afterwards we have three great contemporary writers: in Greek, Gregory of Nazianzus (330-389); in Syriac, Ephraem Syrus (306-378); and in Latin, St Hilary (died 368). The most celebrated of the hymns attributed to the last is the 'Beata nobis gaudia Anni reduxit orbita,' which has been in western liturgies from an early date. St Ambrose (c. 340-397) was almost a contemporary writer with the above three. About 100 hymns are attributed to him, but of these only twelve are accepted by the Benedictine editors of his works, including 'Eterna Christi munera,' 'Deus Creator omnium,' 'O Lux beata Trinitas,' and 'Splendor Paternae gloriæ.' The rest, being in his style and after his manner, are known as Ambrosian hymns. Most of the latter and all of those by St Ambrose are found in the early liturgies of the Western Church. Prudentius (350-410) did not write hymns, but sacred poems, from which portions were taken and incorporated as hymns in the services of the church. For this purpose these extracts were admirably suited and widely used. His 'Corde natus ex Parentis,' which was taken from his poem 'Da, puer, plectrum,' in his *Cathemerinon*, is a good example of this mode of treatment. The 63d edition of Prudentius' *Poems* was published at Leipzig in 1809. This is a splendid testimony to his worth. Sedulius, a contemporary of Prudentius, is known in hymnology by one piece, 'A solis ortus cardine, Ad usque,' of which the second portion, 'Hostis Herodes impio,' is used as an Epiphany hymn in several early breviaries, and altered, as 'Crucelis Herodes Deum,' in the modern Roman Breviary. The 6th century embraces two names of great repute: Venantius Fortunatus (530-609), and Gregory the Great (540-604). Fortunatus' *Poems* are extant in eleven books. Some ten or twelve hymns bear his name, but his right to several of these is contested. His grandest productions are the Passiontide hymns, 'Vexilla Regis prodeunt' and 'Pange lingua gloriosi prælium certaminis.' Gregory's accredited hymns are about a dozen, including 'Audi benigne conditor,' 'Ecce jam noctis,' 'Rex Christe factor omnium,' and 'Summi largitor premii.' The fairly well authenticated hymns of the Venerable Bede (673-735) number ten or twelve only at the utmost, including his 'Hymnum eunamus Domino,' and 'Hymnum canentes martyrum.' Another hundred years give us Paul the Deacon (died c. 799) and St Theodolph of Orleans (died 821), the 'Gloria laus et honor' of the latter being long and well known as a processional hymn for Palm Sunday. St Rabanus (776-856), with his 'Christe Sanctorem decens Angelorum,' and St Odo of Cluny (879-912), with his 'Lauda mater ecclesia,' should be mentioned, as also Fulbert of Chartres (died 1028), author of the 'Chorus novæ Hierusalem,' and Robert H., king of France (972-1031), though their claims to hymn writing are open to question.

(2) Although this brings us to the beginning of the 11th century, the hymn-writers whom we have been enabled to cite are comparatively few. Most of them, however, are names of great standing, and are towers of hymnological strength. When, however, all the compositions of these writers are collected together we still find in the ancient Latin service books and other MSS. a mass of hymnological literature for which no authorship can be found. This is also the case with regard to the succeeding centuries, and more especially with respect to the Prose or Sequence.

(3) Notker Balbulus (c. 810-912), the father of sequence-writing, was a member of the Benedictine monastery of St Gall, his principal work being literary and scholastic. In connection with divine worship he found it difficult to remember the musical notes (*neumes*) set to the 'Alleluia' especially to the final *o*, which were sung between the reading of the Epistle and the Gospel. The adapting of words to these *neumes*, instead of sounding them as musical notes only, was suggested to him by another, and the result was a series of Sequences, or, as we now call them, hymns, which to the number of 115 are known as Notkerian Sequences, but of which less than fifty are by Notker. Of those who followed Notker in this mode of composition Adam of St Victor (an abbey at Paris) was the most prominent. The service-books of the middle ages abound with these compositions, but the greater proportion by far are anonymous. The Notkerian Sequence which is best known to the English reader is that for the Epiphany, translated by Dr Neale as 'The strain upraise of joy and praise, Alleluia.'

(4) Whilst the work of composing hymns and sequences was thus prolific, a few names of great note stand forth in their grandeur as composers of sacred poems as distinct from hymns. It will be sufficient to name St Bernard of Clairvaux (1091-1153), and his grand Passiontide poem 'Salve mundi salutare,' and his contemporary, Bernard of Châny, with his splendid 'Hora novissima,' to show the nature and character of the work which was done. See DRES B.R.E.

(5) The hymns, sequences, and poems referred to above, to the number of several thousands, are those which date from before the 16th century. Some hundreds more were added to the stores of Latin hymnody by the brothers Santeuil and others in the Clunian (1686), the Paris (1736), and other breviaries in France, additions to the latter being as late as 1820. As to the use made of this mass of sacred poetry, we may add that two-thirds or more have been associated directly with divine worship, and the rest are connected with works of private devotion; and that nearly one-fourth have been translated into English.

V. *English*.—English hymnody is a very wide subject, and, if we include therein Anglo-Saxon compositions, it dates from Caedmon (died c. 680). Bishop Aldhelm (died 709) sang sacred poems in the vernacular, and is said to have rendered the Psalter into metre; in Chaucer (1340-1400) we have an early English hymn to the Blessed Virgin; in 1441 T. Brampton's Seven Penitential Psalms, and later carols and additional hymns to the Blessed Virgin Mary. The first instalment of hymns in the vernacular of any moment were those translated from the Latin, and included in the Primers which were issued both before and after the Reformation. These translations were followed by others, some of which are preserved to us in the Book of Common Prayer. Translating, however, soon gave way to paraphrasing, and Latin and German hymns to the Book of Psalms. The supplying of the need occasioned by the suppression of Latin hymns in divine worship at the Reformation, by the introduction of the Paraphrase instead of the hymn, is a history in itself. We can only say that from 1561 to 1696 the authorised book in the Church of England was the 'Old Version' of Sternhold and Hopkins, and from the latter date to the adoption of modern hymn-books, the 'New Version' of Tate and Brady. In the meantime the foundations of English hymnody were being extended. A *resumé* of the work done in the Elizabethan age is given in E. Farr's *Sacred Poetry, chiefly devotional, of the Reign of Elizabeth* (Parker Soc., 1815). The speci-

mens given are either from books of poetry or works of devotion, and are pious utterances in quaint and rugged verse. Later attempts in the same direction, by Dr Donne in his *Poems* (1633), G. Herbert in his *Temple* (1633), C. Harvey in his *Synagogue* (1640), and others, were of a higher stamp, and bore a greater affinity to the modern hymn. At that time no use of these compositions was made in public worship, except in the case of private institutions. The hymn 'Jerusalem, my happy home,' and others of more than usual excellence are of this period.

The first English hymn-book was the *Hymns and Songs of the Church* (1623), by George Wither. The king granted him a patent to bind up the book with the Metrical Psalms; but the whole matter resulted in a failure. In 1641 Wither republished the same, with a few alterations, as *Hallelujah, Britain's Second Remembrance*, and dedicated it to the Long Parliament, but with no better success. The writings of Herrick, Henry Vaughan, William Barton, Bishop Jeremy Taylor, Samuel Crossman, Richard Crashaw, John Austin, Bishop Thomas Ken, and others bring us down to 1737, when the first hymn-book of the modern type (in which the original hymns of various authors are interspersed with translations from other languages) was published by John Wesley for use in the Church of England.

(1) *Church of England*.—The title of Wesley's book was *Collection of Psalms and Hymns* (Charlestown: printed by Lewis Timothy, 1737). The versions of psalms, the translations from Greek and German, and the original compositions were seventy in all. Wesley and his brother Charles soon changed the style of their hymnological productions, and from 1740 to 1780 (the date of the Wesleyan hymn-book) published only their own compositions. John Wesley's hymnological work for the Church of England remained a dead-letter until 1760, when Martin Madan published his *Collection of Psalms and Hymns*, gathered by him mainly from the Wesleys and Isaac Watts, altered without permission to suit his Calvinistic views, and published without leave.

During 1760-1800 nearly twenty distinct hymn-books were issued. Taken as a whole they were Calvinistic in doctrine, crude in arrangement, and indebted to the Wesleys and Nonconformists for seven-eighths of their contents. Three writers only stand out during this period with marked distinctness: A. M. Toplady, John Newton, and William Cowper. During the next twenty years nearly one hundred hymn-books were issued for use in the Church of England, and the places of publication extended to almost every county in the country. Naturally these books varied in their contents; but their general doctrinal tone was distinctly Calvinistic. There was also a greater and more uniform recognition of the order of the Book of Common Prayer than before. The years 1820-50 produced another hundred of hymn-books, amongst them Beckerist's *Christian Psalms* (1833-4), Elliott's *Psalms and Hymns* (1835), and Hall's *Metric Hymn-book* (1836). Other works of importance were Bishop Heber's posthumous *Hymns* (1827), Miss Anker's *Spirit of the Psalms* (1829), Bathurst's *Psalms and Hymns* (1831), and Lyte's *Spirit of the Psalms* (1834), the contents of which, in each instance, were mainly by the same writer. During this period also this score was richly increased by the publication of Koble's *Christian Year*, by the original compositions of several other writers, and by renewed efforts at translation of German and Latin hymns. This immense growth broadened out considerably, and brought the subject of hymnody strongly to the front during the next ten years. The outcome was the publication of over fifty hymn-books in that period, a great accumulation of original hymns and translations, the gradual exclusion of nonconformist hymns, except those of the higher class, from the collections, and a new and intense interest in the whole subject. Additional translations from the Latin and German, together with original com-

positions of great merit, created a longing for something better in the form of a hymn-book for public use. *Hymns Ancient and Modern* (1861) was one answer to this request. Its success was phenomenal. On the one hand it raised a storm of opposition; on the other, during the next twenty-five years it called forth several important works on hymnology, various collections of sacred lyrics for private use, about fifty 'supplements' to and editions of books in common use, and nearly one hundred new hymn-books. Since then new writers whose names have become household words have arisen, and the needs of the increased activity of the church have been met. In the past one hundred and fifty years the Church of England has produced about five hundred hymn-books, and nearly two hundred and fifty authors and translators whose works have been at one time or another in use in public worship. Taken together their original hymns and translations will number ten thousand.

(2) *English Nonconformists*.—The hymnological work which has been accomplished outside of the Church of England is large and important, and has had great influence in all English-speaking countries. A few facts only can be set forth in each instance.

(a) *The Baptists* from the first quarter of the 17th century to the present have been divided into two sections, the Particular or Calvinistic, and the General or Arminian Baptists. The singing of hymns with the former began with B. Keach, about 1673. It had a stormy birth and childhood, for opposition thereto was great, but at the present time hymn singing is a distinctive feature in their worship. The General Baptists also have their official hymn-books, and singing is an essential part of their worship. English Baptist writers number about one hundred, and their hymns two thousand.

(b) *The Congregationalists or Independents* used hymns in public worship some thirty years before the Baptists. Their hymn-books have been many, and their writers numerous. The latter number over a hundred, and their hymns three thousand or more. Although I. Watts, P. Doddridge, and J. Corder are their pride and towers of strength, there are others who have written lyrics of great force and beauty.

(c) *The Methodists* are broken up into several sections, as the New Connection (1796), Primitive Methodists (1810), the United Methodist Free Churches (an amalgamated body dating from 1857), and the Bible Christians (1815). The first official hymn-book of the old body was published by J. Wesley in 1780, and is the groundwork of all the hymn-books of the various branches of Methodism—the Primitive Methodists alone excepted. Usually Methodist hymnody is said to have had a great influence upon English hymnody everywhere. This, however, is only true of the hymns of John and Charles Wesley.

(d) *The Unitarians*, although numerically a weak body, have produced several hymn-writers of great merit. Of their present hymn-books the best is Dr Martineau's *Hymns of Peace and Praise* (1873), which is unequalled amongst Unitarians.

(e) *Other Denominations*, as the Irvingites, the Swedenborgians, the Salvation Army, and many others have each their authors and official hymn-books. The writers and books, however, do not call for special notice.

When the English hymn writers are counted up and their works are tabulated, we have a total of 1000 writers, and 25,000 hymns.

VI. *Irish*.—The Roman Catholics, the Protestant Episcopalians, the Presbyterians, the Methodists, and others in Ireland have been so closely identified with their brethren in England and Scotland that in most instances the same books have been in use in the three countries. The result has been that Ireland has not shaped a hymnody for herself, although in later years a few hymn-books have been published independently. The Irish Church has, however, an authorised hymnal, *The Church Hymnal* 1873, with supplement of later date. In this respect it is greatly in advance of the Church of England.

VII. *Welsh*.—There are references in Welsh history which go to show that some of her ancient bards sang hymns of praise to God as early as the 6th century. The most ancient productions now extant date from the 14th century. After the Reformation the lead was taken by the Established Church, by the publication of Archdeacon Prys's version of the Psalms in 1621. Since then hymn-writing has increased somewhat rapidly, especially since the Methodist movement early in the last century; and at the present time the Established Church and the numerous Nonconformist bodies have each their official or quasi-official hymn-books. Welsh hymnody, although very powerful in the principality, has had little or no influence upon the hymnody of other countries.

VIII. *Scottish*.—One of the most interesting parts of Scottish hymnody is the history of the Scottish Psalter, a work which is interwoven with Scottish history, and has had a powerful influence upon the Scottish mind. The first effectual step taken to provide hymns, as distinct from psalm versions, for public worship in Scotland, was the appointment of a committee of the General Assembly in 1742. This committee presented a draft collection, which was authorised for private use in 1745. The same year a committee was appointed to revise and enlarge the draft for public use. The result was published in 1751 as *Translations and Paraphrases, in Verse, of several Passages of Sacred Scripture, &c.* Of the total contents (sixty-seven in all, not counting the five hymns added at the end) twenty-five are by Watts, five by Doddridge, and two by Tate, the rest being by M. Bruce, T. Blacklock, H. Blair, W. Cameron, J. Logan, J. Morison, and other Scottish writers.

Although the addition of the five hymns to the Paraphrases indicated a desire for a larger choice of hymns in public worship, nothing definite and official was done by the principal sections of Presbyterianism until the publication of the *Hymn-book of the Relief Church* (1794), the *Hymn-book of the United Presbyterian Church* (1852), the *Scottish Hymnal* of the Established Church (1870), and the *Psalms-versions, Paraphrases, and Hymns of the Free Church* (1873). These have been revised, added to, or superseded—notably by the *Hymnary* for the Established, Free, and F.P. Churches in Scotland, and the Irish Presbyterian Church (1898). Much activity has been shown by individuals amongst Presbyterians, Scottish Episcopalians, Evangelical Unionists, Baptists, Congregationalists, Glasites or Sandemanians, Roman Catholics, and others, the outcome of which is a mass of hymnological literature, of which a good proportion is of Scottish origin and of high merit. Amongst the ninety to one hundred Scottish authors and translators whose hymns have taken a high place in the hymnody of the church the most eminent are J. Morison, R. Blair, S. Martin, W. Robertson, H. Bonar, Jane Borthwick, M. Bruce, J. D. Burns, Sarah Findlater, R. M. McCheyne, H. M. Macgill, and R. Wardlaw. The prince of these hymn-writers and the Charles Wesley of Scotland is Dr Horatius Bonar (1808-89).

IX. *American*.—The first book printed in America was the Bay Psalter (1640), consisting of various metrical versions of the Psalms by English authors. The addition of a few spiritual songs in the 2d edition of 1647 was the first departure from the sole use of psalm-versions in that country. This small beginning had at the first a very slow development. The years 1780-1800 witnessed the general recognition of hymns. The Protestant Episcopal Church extended their collection in 1789 to twenty-seven hymns; a collection by the Baptists (the second) was published in 1790;

the Congregationalists had their *Hartford Selection* in 1799; the Wesleyan Methodists a reprint of a *Pocket Hymn-book* originally published at York, and revised after some years of use in 1802; the Universalists, two collections in 1792; the Unitarians, a selection in 1795; and the Presbyterians, Watts at first, and then an official collection in 1828. In these books American hymn-writers had a very limited representation, most of the hymns being by English authors; but year by year the American element became more pronounced as hymnals followed hymnals in the various religious communions. In 1800 an original hymn by an American was a novelty in any collection; now no American hymn-book of the highest class can do with less than two hundred and fifty authors and translators, and of these not less than fifty should be Americans. This percentage, as the outgrowth of some eighty years, is remarkable. Each religious communion has done its part in bringing about this great result. Of the two hundred and fifty authors and translators, the Baptists and the Unitarians number over forty-five each, the Congregationalists about forty; the Protestant Episcopalians and the Presbyterians about thirty each, the Methodists less than twenty, and the Universalists about ten. The remaining thirty include Quakers, Reformed Germans, Reformed Dutch, &c. Several of these writers have an European reputation, as Bishop Coxé, Bishop Doane, C. W. Everest, and W. A. Muhlenberg (Episcopalians); T. Hastings and J. W. Alexander (Presbyterians); H. M. Dexter, T. Dwight, and Ray Palmer (Congregationalists); P. Bliss, Lydia Sigourney, and S. F. Smith (Baptists); Fanny Van Alstyne and W. Hunter (Methodists); S. G. Ballinch, W. C. Bryant, W. H. Burleigh, Emerson, Holmes, Longfellow, S. Longfellow, Lowell, and E. H. Sears (Unitarians); and the Quaker poet Whittier.

The number of hymn-books published in America during the past hundred years accounts to a great extent for this great activity in hymn-writing. At the present time each denomination, and there are many, has its official hymn-book, or its quasi-official book or books. For good work opportunities for publication thus abound, and the finer productions are assured a certain circulation and a possible immortality.

X. *French*.—The French metrical psalters have a history distinct from French hymns and hymn-books. The complete psalter of Marot and Beza (1552-62) was the psalm-book of the Reformed Church until its place was to some extent filled by the new version of Comart (1677-79), and the revision of the same by Pietet and others in 1695. As in other countries, the psalter subsequently gave way to the hymnal, and the versions of private individuals were mainly of public value in proportion as they yielded suitable pieces for the same. The writing of hymns in the vernacular began in the 16th century as in Germany and elsewhere with translations from the Latin. The Roman Catholics, the Huguenots (in their day), the Reformed Church, the French Moravians, the Methodists, and various evangelical societies, have each their book or books of hymns for divine worship, in which, although there are original compositions by French authors, the larger proportion are translations from English and German hymns. *The Brevel* has produced the greatest French Protestant hymn-writers, at the head of whom stands César Malan (1787-1864), whose printed and MS. hymns number about one thousand. Associated with him, directly or indirectly, in the same religious movement were Ami Bost, H. Empaytaz, Abelé d'Aubigné, Felix Neff, Henri Lutteroth, A. Vinet, A. Monod, and others, men of

world-wide reputation and influence, who have given a position to French hymnody unknown to it before.

XI. *German*.—In the German language there are not less than one hundred thousand hymns, of which about ten thousand have passed into German hymn-books of various dates, and nearly a thousand are regarded by German critics as classical. The first were contemporary with the earliest Latin sequences of St. Notker and others; the last are the productions of living men.

(1) *The First Period* begins with Otrid of Weissenburg (c. 868), and was continued by others until the time of Luther. The greater part of the hymns of this period were translations from the Latin, and all were in strict doctrinal accord with the Church of Rome.

(2) *The Second Period* (1520-1648) opens with the hymns and psalm-versions by Luther, and embraces the Reformation period to the peace of Westphalia. The principal writers were Luther, Justus Jonas, Alber, Spengler, Hans Sachs, Speratus, N. Decus, and others. The writings of these authors reached to about 1570, and have a distinct churchly character of their own. From 1577 to 1618 hymn-writing and hymn-book making continued very much on the old lines, and numbered amongst the writers Selmecker, Ringwaldt, Herberger, and P. Nicolai. The miseries of the Thirty Years' War changed the whole aspect of hymn-writing for a time; by the introduction of a strong personal element of faith and courage, and hope begotten of suffering. The names of a few of these writers will recall some of the finest hymns of this kind in the German language: Opitz, Heermann, M. A. von Lowenstern, Altenburg, Runkart, Bach, and Rist.

(3) *The Third Period* was a transitional one, and led up to the Pietistic and Moravian writers of the next era. It had amongst its hymn-writers P. Gerhardt, Franck, Neumark, Scheffler, and Louise Henriette of Brandenburg. Of these the greatest was Gerhardt, who is second only to Luther in German hymnody, and Scheffler, whose love for Christ was first in everything. This orthodox, mystic school, with its deep experimental piety, was soon lost in the Pietism of the next period.

(4) *The Fourth Period*, commonly known as the Pietistic and Moravian era, 'was a reaction against the dry scholasticism and cold formalism of the Lutheran Church,' and an emphatic pronouncement in favour of 'practical, personal, and experimental piety.' On the Lutheran side the leading writers were Speier, Francke, Richter, Freylinghausen, G. Arnold, J. Lange, Dessler, Rambach, Bogatzky, Schmolek, and Hiller; and on the Moravian, Count Zinzendorf. These names recall numerous hymns of deep spirituality, high refinement, and great power.

During this same period the German Reformed Church broke away from its long-continued and almost exclusive use of the Psalms in metrical form. Their first hymn-book appeared at Zurich in 1540. This was followed by A. Lobwasser's rhymed translation of the French Psalter of Marot and Beza in 1573. Another hundred and fifty years brought them into closer hymnological conformity with their Lutheran brethren, and produced amongst others three well-known hymn-writers, J. Neander, Lampe, and Tersteegen.

(5) *The Fifth Period* embraced about sixty years (1757-1817), and covers the time when the great wave of Rationalism broke in upon the German churches, and for a time changed the whole aspect of their hymnody. Old hymns were altered or entirely rewritten, and new hymns written partaking of the nature of rhymed sermons on the existence of God, the immortality of the soul, the dignity of man, the obligations of moral duties, and kindred subjects. To the hymn-writers of this order there were a few notable exceptions, which included Gellert, Klopstock, J. C. Lavater, and M. Claudius, the greatest being Gellert and Klopstock.

(6) *The Sixth Period* is rich in writers. Beginning almost with the 19th century, it extends to the present time, and embraces the well-known names of F. von Hardenberg ('Novalis'), E. M. Arndt, F. A. Krummacker, F. W. Krummacker, A. Knapp, J. P. Lange, Spitta, and Gerok.

This digest of the hymnological work of more than a thousand years in one language can give

only the slightest idea of what was done. Little or nothing has been said about the multitude of hymn-books (*Gesangbuecher*) which were issued and brought into common use in the church and in the home, nor of the metrical versions of the Psalms, which have a history of their own. We can do no more than recall and emphasise the facts, and refer to special treatises for details. The influence of German hymns upon English and American hymnody has been very great. In fact, until the modern revival of translating hymns from the Latin and other languages, German was almost the only source from whence hymns other than English were taken for use in the hymn books of Great Britain and America; and at the present time, especially in America, it holds a prominent position in the hymnals of almost every party and creed. For the Dutch, Italian, Bohemian, Moravian, and Scandinavian hymns, and those in use in foreign missions (in more than 150 languages and dialects), see the present writer's *Dictionary of Hymnology* (1892).

Conclusion.—From the outset of the propagation of Christianity throughout the nations of the earth it became a necessity to preach to the people in their own languages, and gradually to supply them with hymns in their own tongues. This has resulted, as we have seen, not only in a great number of languages being represented in Christian hymnody, but also in a vast variety of metrical forms being found therein. Some of these forms are intimately associated with the ancient classical measures, whilst others are widely divergent therefrom, and seem to have had little or no laws of control beyond the fashion of the period or the fancy of the writers. With this broadening out of languages and forms came also a rapid increase in the number of subjects which engaged the attention of Christian poets. At an early stage of church history reverent strophes in praise of the Holy Trinity, and especially in adoration and praise of the Eternal Son, together with a metrical homily or two and a few impassioned songs on the practical side of Christian life, formed the staple of sacred song. We have seen how the expansion of church life and the development of doctrine and practices called forth a fuller and more extended hymnody, until every incident of importance in Bible story, every conceivable shade of Christian doctrine and ritual, every epoch in the church's history, every experience in her children's life, from the sufferings of her little ones to the magnificent self-sacrifices of her martyrs, have been enshrined in sacred song.

Hyōgō, or **KOBE**, a port of central Japan, situated on the west shore of the Gulf of Osaka, about 20 miles S. of that city. Hyogo is properly on the west side, and Kobe on the east of an unimportant river. Open to foreign trade since 1868, it is connected by railway with Osaka, and has a large direct foreign trade with Europe, America, and Australia. The place has foreign banks, wharves for ocean steamers, extensive shipbuilding yards, and a large paper mill. Pop. (1895) 153,382. The imports have an annual value of about £5,000,000; the exports (rice, tea, silk, camphor, fish, matches, porcelain, umbrellas) of about £1,000,000.

Hyoid Bone, in human anatomy, is a bony arch consisting of five movable parts, quite separate from the rest of the skeleton, and lying in the fleshy parts of the neck between the root of the tongue and the larynx (see TONGUE). For the hyoid bone of the dog, see the figure at Dog.

Hyoseyanus. See HUSBANE.

Hypatia, daughter and pupil of Theon, an astronomer and mathematician of Alexandria, was born in the later part of the 4th century A.D. Her

learning and wisdom made her the most influential teacher in Alexandria, and the fame of her lectures drew round her students from all parts of the East where the influence of Greek thought and knowledge was felt. The philosophy she taught seems to have been an eclecticism, the results of an endeavour to combine Neoplatonism with Aristotelianism; but her thoughts were principally given to astronomy and mechanics. Personally she was held in such great esteem, and such reliance was placed on her judgment and sagacity, that the magistrates used frequently to consult her on important cases. At this time the Bishop of Alexandria was Cyril (q.v.), a fierce hater of heathens and heretics. With his connivance, if not at his instigation, certain savage monks from the Nitrian deserts, headed by one Peter, a reader, attacked Hypatia in the streets as she was returning from her lecture-room, dragged her from her chariot, hurried her to the Cæsareum (then a church), there stripped her naked, and hacked her to death with oyster shells, after which she was torn to pieces, and her limbs carried to a place called Cinanon, and there burned to ashes (415). None of her writings have survived. Kingsley's romance, *Hypatia*, appeared in 1853.

Hyperæsthesia (Gr. *hyper*, 'over,' *aisthēsis*, 'a sensation'), in the most general sense of the word, denotes an excessive excitability of the parts of the nervous apparatus which have to do with sensation, special or common. Abnormal sensibility to pain is, however, more correctly called *hyperalgesia*. In this condition, as in Tic-douloureux (q.v.), the slightest stimulus may cause a paroxysm of pain, even a current of air or a noise bringing on an attack; while in hyperæsthesia of the special senses bright flashes of light may be seen, sounds may be heard, and even smells and tastes experienced in the absence of any objective cause. Of the diseases predisposing to hyperæsthesia hysteria is far the most frequent; but it is sometimes induced by rheumatism, gout, skin diseases, inflammatory affections of the central nervous system, while it often adds greatly to the distress in the early stages of various fevers. The treatment of hyperæsthesia is that of the morbid change on which it depends, but the local application of anodynes, ice, or warm poultices, and sometimes the use of electricity may do much to diminish the patient's sufferings for the time.

Hyperbola. If two similar cones be placed apex to apex, and with the lines joining the apex and centre of base in each, in a straight line; then if a plane which does not pass through the apex be made to cut both cones, each of the two sections will be a *hyperbola*, as PBN, P'AN'.

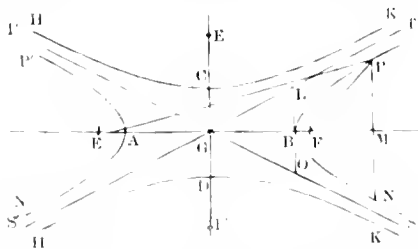

It is, viewed analytically, the locus of the point to which the straight lines EP, FP differing by a constant quantity are drawn from two given points, E and F. These given points are called the *foci*, one being situated in each hyperbola. The point G, midway between the two foci, is called the *centre*, and the line EF the *transverse axis* of the

hyperbola. A line through G perpendicular to the transverse axis is called the *conjugate axis*; and a circle described from centre B, with a radius equal to EG, will cut the conjugate axis in C and D. If G be taken for the origin of co-ordinates, and EM and E'P' for the axes, the hyperbola is expressed by the equation $\frac{x^2}{a^2} - \frac{y^2}{b^2} = 1$. (GB = a, GC = b). The

hyperbola is the only conic section which has Asymptotes (q.v.); in the figure these are GT, GT', GS, GS'. It also appears that, if the axes of co-ordinates be turned at right angles to their former position, two additional curves, HCK, H'DK', will be formed, whose equation is $\frac{x'^2}{b^2} - \frac{y'^2}{a^2} = 1$. These

two are called *conjugate hyperbolas*, and have the same asymptotes as the original hyperbolas. These asymptotes have the following remarkable property: If (starting from G) the asymptotes be divided in continued proportion, and from the points of section lines be drawn parallel to the other asymptote, the areas contained by two adjacent parallels and the corresponding parts of the asymptote and curve are equal; also, lines drawn from the centre to two adjacent points of section of the curve enclose equal areas. The equation to the hyperbola when referred to the asymptotes is $xy = ab$; which shows that as the ordinates decrease in geometrical progression the abscissæ increase in the same ratio.

Hyperboreans (i.e. dwellers beyond Boreas or the North Wind), a name given by the ancients to a mythical people, whose land was generally supposed to lie in the extreme northern parts of the world. As the favourites of Apollo they enjoyed an earthly paradise, a bright sky, a perpetual spring, a fruitful land, unbroken peace, and everlasting youth and health. In the modern science of anthropology the term Hyperboreans is sometimes used to designate certain peoples, such as the Tchuktchis, Aino, Kamchadales, &c., who dwell in the north-east of Asia and the north-west and north of North America, and who cannot be classed either with the Indians or the peoples of the Asiatic plateau.

Hypericaceæ, or HYPERICINA, a natural order of about 300 known species, trees, shrubs, and herbaceous plants, widely distributed over the world, and in very different climates, but particularly numerous in North America. The species of *Vismia* yield a substance resembling gamboge. Many of the Hypericaceæ belong to the genus *Hypericum*, or St John's Wort (q.v.).

Hyperides (more correctly Hypericides), the Greek orator who, on the whole, ranks next to Demosthenes, excelling him in grace though inferior to him in moral power, was probably born about the same time as Demosthenes. By birth belonging to the middle class, he became a professional advocate, and earned large sums of money, which he spent with a generous hand alike on his private (somewhat scandalous) pleasures and on patriotic purposes. His *casuologia* against Philocrates assured his professional position and brought him on to the stage of politics, where he was destined to play a notable part (343 B.C.). From the first he was an opponent of the party which advocated peace with Philip, and a supporter of Demosthenes. The importance which attached to him as a politician at this time is shown by the fact that he was chosen by the Areopagus to represent the Athenian case before the Amphictyons in the dispute as to the control of the Delian temple. During all Demosthenes' manful struggles against Philip up to the fatal field of Chæronea, when, with the defeat of Athens, the political liberty of Greece practically came to an end and the supremacy of Macedonia was established, Hyperides

was the trusty and valuable supporter of Demosthenes. Even after the death of Philip, and during the early portion of Alexander's career, the two orators continued to be faithful allies. Only when Demosthenes endeavoured to follow an impossible *via media* in the matter of Alexander's absconding minister, Harpalus, did Hyperides break with his former leader, and head that accusation of bribery against Demosthenes which not only resulted in the banishment of the great orator but committed Athens to the fruitless revolt against Macedonia, known as the Lamian war. The leaders of this revolt were Leosthenes and Hyperides; the former perished in battle, the latter was put to death by Antipater (322 B.C.). It is remarkable that although Hyperides was admired and studied in Roman times, although his works were not only known to Photius in the 9th century but actually preserved in MS. in the King's Library at Buda until 1526, when Buda was taken by the Turks, it was not until 1847 that we had any specimens of Hyperides' oratory by which to judge for ourselves of his powers. In that year Mr A. C. Harris of Alexandria purchased a papyrus at Thebes containing portions of Hyperides' speech against Demosthenes and of his speech for Lycophron. At the same time Mr J. Arden was offered a papyrus, while he was travelling in Egypt, which turned out to belong to the same volume as that bought by Mr Harris, and to contain the remainder of the speech for Lycophron, and also the whole of the speech for Euxenippus. In 1856 another traveller, Mr Stobart, obtained from the same neighbourhood another papyrus containing the Funeral Oration of Hyperides. And in 1889 M. Eug. Revillout announced that the Louvre had on his proposition purchased a papyrus which contains fragments of the first speech against Athenogenes, and is much better calculated to give us an idea of the skill of Hyperides than anything acquired by England (*Revue des Etudes Grecques*, January-March 1889).

What most impresses one in reading Hyperides is his grace, next his indolence, and always his urbanity. His grace is nothing affected or assumed, nor is it useless ornament. Hyperides is a practical, not an epidemic orator, and means business. His grace is that of a man performing a feat well within his powers, and that not a despicable feat. At the same time he is indolent, apparently because there is really no need to exert himself. He will not take the trouble to pick and choose words; he makes the one that comes first—obsolete, obsolescent, proverbial, conversational, or what not do his work. He will not turn his sentences over mentally again and again before uttering them, so that they may roll out smooth, polished, balanced, and finished; he will rather let them come out at their own length, and as they list, he can pull them up at any time with effect and without effort. He is always transparent, never monotonous as is Demosthenes; he is witty to a degree, refined in his raillery, and his irony is delightful. Above all he never in his keenest attacks passes the bounds of good taste, as does Demosthenes. Finally, it must be remembered that what we possess cannot give us an adequate idea of the oratorical powers of Hyperides; of the speeches against Demosthenes and for Lycophron we only possess fragments; the speech for Euxenippus is indeed complete, but is never even mentioned by ancient critics, and therefore cannot have been one of his best productions. And as to the speech against Athenogenes, the anonymous writer of the treatise on the Sublime praises it indeed, but praises it as a pretty little speech. The best account of Hyperides is that given by Blass in his great work, *Die Attische Beredsamkeit*, III. ii. 1-72. Churchill Babington's

original edition of the Orations for Lycophron and for Euxenippus (Cambridge, 1853) will always be valuable. The best text of Hyperides' works is that of Blass in the Teubner series. See Hager's *Quaestiones Hyperidae* (Leip. 1870); and the *Quarterly Review* for April 1894.

Hyperion, a Titan, son of Uranus and Ge, and father of Helios, Selene, and Eos. Homer and later poets apply the name as a patronymic for Helios himself. Hence the attribute of beauty has been connected with the name, as in Shakespeare's 'Hyperion to a satyr.'

Hypersthene (Gr. *hyper*, 'above,' *stheneis*, 'strength'; so called to distinguish it from Hornblende, q.v., with which it was formerly confounded), a rock-forming mineral which crystallises in orthorhombic forms. It is an anhydrous magnesian silicate, containing a large percentage (15-24) of ferrous oxide with very little alumina. It is generally dark green or raven-black in colour, but has a pearly or metallic lustre when fractured across the cleavage-planes. This is due to the presence of very numerous minute brown scales of some foreign substance, which are arranged in lines along these planes. This mineral occasionally occurs massive, like hornblende, as in the island of St Paul on the Labrador coast. It is met with also as an occasional constituent of some eruptive igneous rocks, as in certain andesites and porphyrites, and in plutonic rocks, such as gabbro.

Hypersthénite, a more or less coarsely crystalline igneous rock allied to Gabbro (q.v.). It is an aggregate of labradorite (felspar) and hypersthene, and is of plutonic origin.

Hypertrophy (Gr., 'over-nourishment') is the term applied in medicine to the enlargement of certain organs of the body. The best examples of this change are seen in the muscular system, where it may occur altogether independently of disease. The huge bosses of flesh that stand prominently forward in the arm of a blacksmith or of a pugilist, and in the leg of an opera-dancer, are illustrations of hypertrophy where the general health may be perfect. In double organs, such as the kidneys and lungs, if the organ on one side degenerates through disease, the organ on the opposite side is often found to enlarge and carry on double work. In these cases hypertrophy is an effect of disease, but is at the same time a resource of nature to preserve life. There are, however, cases in which the hypertrophy has a hurtful instead of a conservative effect, as, for example, hypertrophy of the thyroid gland, constituting the disease known as goitre or bronchocele, hypertrophy of the prostate gland, of the spleen, &c. The following are, according to Paget, the conditions which give rise to hypertrophy: (1) The increased exercise of a part in its healthy function; (2) an increased accumulation in the blood of the particular materials which a part appropriates in its nutrition or in secretion; (3) an increased afflux of healthy blood. In hypertrophy of the muscular tissue the first and third of these conditions are present. In hypertrophy of the fatty tissue, constituting obesity, there is an excess of fat or of its chief elements in the blood.

Hypnasis. See SUTLER.

Hypnotism, or PSYCHO-THERAPEUTICS. From 1784, when Mesmer at Paris claimed the power of curing all manner of disease by 'animal magnetism,' this subject has been more or less tabooed by the medical profession. The nature of hypnotism and methods of inducing it are discussed at ANIMAL MAGNETISM. It is only within the last few years that it has received the scientific investigation which it deserves; but hypnotism

is now extensively used on the Continent in treating disease, and is slowly finding its way into practice in Britain. It is impossible to suppose that hypnotism will ever fulfil the sanguine expectations of many of its exponents, though it seems certain that it will render great aid as a therapeutic agent in treating some kinds of diseases. It is still necessary to write very guardedly upon the subject, as its action when used for the cure of disease is imperfectly understood; but that it is useful as a method of treatment is demonstrated by many cures which have been thoroughly investigated by the highest scientific men. Hypnotism is not any longer to be regarded as a mystery or as a superhuman gift, for its action can for the most part be explained by our present knowledge of physiology and psychology. The chief reason why hypnotism cannot be universally employed as a therapeutic agent is the fact that only a certain proportion of persons can be hypnotised. The proportion, however, of persons insusceptible to its power is much less than was at one time thought; and, when used therapeutically, somnambulism, the deepest stage of hypnotism, is not necessary. On the Continent it is found that about 80 per cent. of the inhabitants can be hypnotised.

Hypnosis may be used in two ways in relation to disease. In the first place, simple sleep is induced, and sleep when produced without the action of drugs is often of great importance, and of itself aids in treatment. Again, in many cases when the person is asleep, suggestions may be made to him which will abolish pain, and which in some diseases will bring about either the relief of symptoms or the cure of the disease. Every one knows that the mind influences the body, and that concentrated thought can bring about sensations in various localities. It is upon this knowledge that the hypnotist bases his practice. The patient being placed in a hypnotic sleep, his attention is directed to various parts of the body, and very often the effect is increased through local stimulation by means of passes or rubbing. During the hypnotic sleep the patient is uninfluenced by his surroundings, and therefore he is all the more open to suggestions, and no disturbing influences diminish his powers of concentration. By means such as these neuralgic or rheumatic pains may frequently be removed; headaches may often be cured, and so may some forms of dyspepsia, as well as the various manifestations of hysteria and hypochondriasis, and even functional paralysis. It is found, too, that hypnotism is useful in dipsomania and in treating persons addicted to opium eating and other depraved tastes. At present it cannot be said that hypnotism is of use in any disease having an organic origin, although in such diseases various symptoms, especially those of pain, may be removed successfully. It is quite possible for operations to be performed upon persons under the hypnotic influence without the slightest pain being felt by the patient; but as various other anaesthetics are more easily employed, it is only in a few cases where these are contra-indicated that hypnotism will be used in this connection.

For educational purposes it is held possible to impress a person in the hypnotic sleep with ideas which will modify his usual character. For instance, it seems possible in many cases to cure persons of bad habits, such as stealing, lying, or the excessive use of alcohol; and on the Continent attempts are being made to influence habitual criminals for good by means of hypnosis. Young children, defective in brain power or constitutionally vicious, may be improved by careful hypnotic treatment. It is a mistake to suppose that hypnotism can only be used successfully in treating nervous or hysterical persons. Such

people are often difficult to hypnotise, and there is always a danger of either increasing their troubles or in some cases of inducing insanity. Ordinary individuals, especially those who have learned to obey, are the subjects whom a hypnotist would prefer to treat. Children at school, soldiers and sailors, and officials of all ranks, are the classes from which the most brilliant successes have been obtained hitherto in treating disease. In many cases of insanity hypnotism may be used with advantage as a therapeutic agent, although its employment in these cases is not by any means easy. Persons suffering from hallucinations, it is said, have been cured, and those who suffer from the painful result of some grievous trouble have been restored by having the incident blotted out from their memory.

Although hypnotism has power for good when properly used by medical men, it is an exceedingly dangerous weapon in the hands of the unskilful or unscrupulous. All public exhibitions of hypnotism should be prohibited by law, as persons experimented upon have been rendered lunatics, or had their nervous systems severely damaged. Crimes have been committed by persons who have been hypnotised. Just as a person when hypnotised is rendered extremely impressionable, and therefore capable of receiving beneficial suggestions, so he is nearly as liable to receive suggestions for evil; and it is quite possible for him during the hypnotic sleep to be impressed with the belief that he is to commit some act after he has awakened from the sleep—an act he is safe to do, acting at the time as an automaton. It is absolutely impossible for a person to be hypnotised unless he has the idea of what is going to happen. It is a psychical and not a physical influence which brings about the condition. Only persons whose will-power is weakened by fear, or by the idea of a supposed power which influences them in spite of themselves, can be hypnotised without full consent on their part; but the oftener a person is hypnotised the more easily may he be subsequently affected.

See Bernheim, *Suggestive Therapeutics* (trans. by Herter, 1889); Tuckey, *Psycho-therapeutics* (3d ed., 1891); and other books on hypnotism by Bjornstrom (1889), Kingsbury (1891), Comrnelles (1891), Vincent (1893), and Hart (denouncing it as witchcraft, 1894); and the article CHARCO.

Hypnotics. See NARCOTICS, SLEEP.

Hymnum, a genus of mosses belonging to the order Bryineæ. Archegonia and capsules are borne on special lateral branches. The sexual organs are formed in August and September, and the capsules take from ten months to a year to ripen. Many species are remarkable for their beauty, and are often used for decorative purposes. Their distribution is universal.

Hypocaust, a form of furnace used by the Romans for the purpose of heating baths and apartments. It was placed in a chamber beneath the floor, and the heated air and products of combustion were made to circulate round the walls and under the floor by means of hollow tubes or a hollow lining, and were also carried in pipes to other rooms. See BATHS.

Hypochaeris, a genus of plants of the natural order Compositæ, sub-order Cichoroacæe, of which one species, *H. radicata*, or Long-rooted Cat's ear, is extremely common in meadows and pastures in Britain. Its leaves spread on the ground, and resemble in form those of the dandelion, but rough; the stem is branched, the flowers not unlike those of the dandelion, but smaller. Cattle eat this plant readily, and its abundance is not deemed injurious to pasture or fodder.

Hypochlorous Acid. HOClO , is the acid contained in bleaching powder. It can only be obtained as a dilute solution, as in the concentrated state it is very liable to decomposition. It is a powerful bleaching agent, and forms a series of salts, *hypochlorites*, which also possess bleaching properties. The chief of these are the hypochlorites of lime and soda. The lime salt is the important constituent of bleaching powder, while the soda salt is prepared commercially by passing chlorine into a solution of soda. For further information, see BLEACHING POWDER. *Hypo*, in composition (Gr. "under"), is used much like *sub*, from Latin. Hypochlorous acid has less oxygen than chlorous acid; hyposulphuric has less oxygen than sulphuric, but more than sulphurous acid. Hypophosphates are salts formed by hypophosphoric acid and a base.

Hypochondriasis (so called from its supposed connection with the hypochondriac regions of the Abdomen, q.v.), a disease characterised by extreme increase of sensibility, palpitations, morbid feelings that simulate the greater part of diseases, exaggerated uneasiness and anxiety, chiefly in what concerns the health, &c. In extreme cases it becomes a species of melancholia. The disease is intimately connected with, if not caused by, disorder of the digestive functions. See INDIGESTION, INSANITY.

Hypodermic Injection. This method, first introduced by the late Dr. Alexander Wood of Edinburgh, is an extremely valuable one in certain cases, though its applicability is limited. It consists in the injection of a solution of the substance to be given beneath the skin, by means of a fine hollow needle to which a small syringe is attached. The prick given by the needle is much less acutely felt by the patient if the needle be lubricated with carbolic oil or the like. Absorption from the subcutaneous tissue takes place speedily, and is not interfered with by vomiting, or other conditions of the stomach which may delay or prevent the entrance of the remedy into the system by that channel. The action of the drug is thus at once more rapid and more certain than when administered by the mouth; and a smaller dose is required. Only such substances as can be given in small bulk and in an unirritating condition are available. It is thus chiefly of use for the vegetable alkaloids, of which morphia is far the most often employed. It need hardly be said that it is to be used only by skilled hands. The same method is largely employed in experiments on the action of disease poisons in animals, and in Pasteur's treatment of hydrophobia; see also DIPHTHERIA, TETTERLE.

Hypos tasis, the Greek term used to designate the distinct subsistence of the three persons of the Trinity (q.v.).

Hypothec, a term in the law of Scotland, but not used in England, to denote a lien or security over goods in respect of a debt due by the owner of the goods. Thus, a law-agent or attorney has a hypothec over the title-deeds of his client in respect of his account or bill of costs; and the landlord of agricultural subjects held under leases current at the 11th of November 1881 has a hypothec over the furniture or crops of his tenant for the current rent. The Hypothec Abolition (Scotland) Act, 1880, did away with the landlord's hypothec for the rent of all other land exceeding two acres let for agricultural purposes. See LANDLORD AND TENANT.

Hypothense, the name of that side in a right-angled triangle which is opposite to the right angle. The well-known property of the hypothense, that the square described on it is equal to the sum of the squares described on the

other two sides, is proved in the 47th proposition of the first book of Euclid's *Elements*.

Hyracotherium, a genus of fossil ungulates, established in 1839 by Owen for a small Eocene animal about the size of a hare, to which, however, he afterwards gave the name of *Phiolophus*. See HOARSE.

Hyrax, a genus of mammals representing a distinct order, the affinities of which are very obscure, and unilluminated by the discovery of any fossil forms. "Feddle folk" as the species of hyrax (so-called "cony") are, they find, according to

many, their nearest allies in the huge elephants or in the ungulates proper. In size they are like rabbits; but the name "cony," which really belongs to the rabbit, is not very appropriate; in appearance they rather suggest marmots. They are natives of

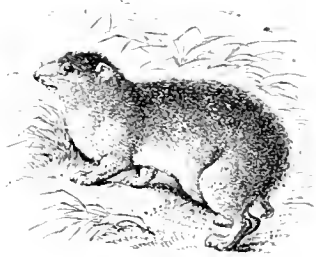

Hyrax sylvaticus.

Africa and Syria, and live among the rocks, in stony deserts, or on trees. The plump body, thick head, small ears, short slender limbs, rudimentary tail, soft yellowish gray or brownish fur are obvious external characteristics. Closer examination shows many peculiarities. The snout, which has a cleft upper lip, is somewhat rodent-like, and so are the rootless, persistently growing curved upper incisors, except that they have a prismatic shape and a sharp point instead of the chisel edge of rodents. The entire dentition is expressed in the formula $\frac{2.1.1}{1.1.1}$, and the back teeth are in pattern distinctly like those of the rhinoceros and some other ungulates. There are four toes on the anterior limbs, three on the hind, all with short broad nails except the inner toe of the hind-foot, which bears a curved claw. The feet strikingly suggest those of rhinoceros or tapir, and are interesting in the further peculiarity that the naked sole is furrowed in such a way that the hyrax can in gecko-like fashion cling to the vertical sides of rocks and trees. Among the many characteristics of the skeleton may be noticed the large number (28-30) of back and loin (dorso-lumbar) vertebrae. The brain and skull most resemble those of ungulates; the stomach recalls that of horse or rhinoceros; the placenta is zonary as in elephants and carnivores.

There are numerous species, sometimes referred to two genera, *Hyrax* and *Dendrohyrax*. The former is represented by *H. capensis*, the Cape Damian, Klippdass, or Rock-badger; *H. sylvaticus*, the Shaphan (mis-translated "cony" of Scripture); and *H. habessinicus*, the Ashtok of the Abyssinians. These live in companies, usually in holes among the rocks, and feed on shoots, grass, flowers, and the like. In reference to the Scripture account it may be noted that the hyrax does *not* chew the cud, though it moves its jaws very constantly. Though only two are born at a birth, the rate of multiplication is very rapid, keeping pace with ravages of carnivores, which are very deadly in spite of the caution and even sentinels of the hyraxes. Of different habit, and sometimes referred to the second genus, *Dendrohyrax*, are certain hyraxes which, in West and South Africa, live in trees, e.g. *D. arboreus* and *D. dorsalis*. The members of this order, so puzzling zoologically, are playful, good humoured, and wary.

Their flesh is sometimes eaten, and is said to resemble rabbit's.—*Hyrcanium*, a supposed medicine for certain nervous diseases, was made from the mixed urine and feces of the Cape Hyrax.

Hyrcania, an ancient district of Asia, of indefinite extent, bordered on the Caspian Sea (sometimes called *Hyrcanica Mares*) and the river Oxus. It corresponded with the modern Mazanderan and Asterabad.

Hyrcanus, the name of two Jewish high-priests and princes of the Hasmonean family (see MACCABEES). (1) JOHN HYRCANUS, son of Simon Maccabæus, who ruled 135-105 B.C., was at first tributary to the Syrians, but on the death of Antiochus made himself independent, subdued the Samaritans on the north, and forced the Idumæans on the south to adopt the laws and customs of the Jews. He also concluded an alliance with the Romans, and extended his territories almost to the ancient limits of the Davidian monarchy. Originally a Pharisee, he subsequently attached himself to the party of the Sadducees, who were anxious to keep on good terms with the Romans, and who discountenanced the turbulent religious patriotism of the Jewish masses. Hyrcanus was, comparatively speaking, a just and enlightened ruler, and the country enjoyed great prosperity during his reign. He left five sons, two of whom, Aristobulus and Alexander, governed with the title of king.—(2) HYRCANUS II., son of Alexander, and grandson of the preceding, was a feeble prince. On the death of his father (78 B.C.) he was appointed high-priest by his mother Alexandra, who ruled Judæa herself for the next nine years. After her death (69 B.C.) his younger brother, Aristobulus, a braver and more energetic man, seized the government, and forced Hyrcanus to withdraw into private life. He failed to win back his dominions, until Pompey began to favour his cause. After some years of tumultuous fighting, Aristobulus was poisoned by the partisans of Ptolemy (49 B.C.), and Hyrcanus for some time possessed the dignity of high-priest. Caesar (47 B.C.), on account of the services rendered to him by Antipater of Judæa, made the latter procurator of Judæa, and thus left in his hands all the real power. Antipater was assassinated, and Antigonus, son of Aristobulus, with the help of the Parthian king, invaded the land, captured Hyrcanus by treachery, cut off his ears, and carried him off to Seleucia on the Tigris. Some years later Herod, son of his old friend Antipater, obtained supreme power in Judæa, and invited the aged Hyrcanus home to Jerusalem. He was allowed to depart, and for some time lived in ease and comfort; but, falling under suspicion of intriguing against Herod, he was put to death, 30 B.C.

Hyslop, JAMES, poet, was born in the parish of Kirkcubright, Dumfriesshire, July 23, 1798. While acting as a shepherd near Aird-moss, Ayrshire, the scene of a Covenanting skirmish and Cameron's death (1680), the traditions of the district stimulated his imagination to the writing of his best-known poem, 'The Cameronian's Dream,' which appeared in the *Edinburgh Magazine* (1821). Hyslop, who had prepared himself by persevering private study for teaching at Greenock, through the influence of Lord Jeffrey was appointed tutor on board the *Doris*. While tutor on board the *Three* man-of-war he died of fever at St. Jago, Cape Verd Islands, November 4, 1827. An edition of his poems was printed from his manuscript book by the Rev. P. Meares, Coldstream (Glasg. 1887). Mr Hamish McCum set his 'Cameronian's Dream' to music in 1889.

Hyssop (*Hyssopus*), a genus of plants of the natural order Labiate, distinguished by four

straight diverging stamens, and a calyx with fifteen ribs. The known species are few. The Common Hyssop (*H. officinalis*) is a native of the south of Europe and the East. It is found on the Alps of Austria. It is a half-shrubby plant, about 1½ feet high, the upper part of the stems quadrangular, the leaves evergreen and lanceolate, the flowers in one-sided whorled racemes. The flowers are generally of a very beautiful blue. It has an agreeable aromatic odour. It has long been in cultivation for the sake of its leaves and young shoots, which are sometimes used for culinary purposes as a seasoning, but more generally in a dried state as a stomachic and carminative. A syrup made with them is a popular remedy for colds. The virtues of hyssop depend on a volatile oil. The hyssop of the Bible has been supposed to be some species of *Phytolacca* (q.v.), as *P. acinosa*, a native of the Himalaya; but on the authority of Dr Royle it appears to have been the common Caper (q.v.). Hedge Hyssop is *Gratiola officinalis*. See GRATIOLE.

Hysteria (Gr. *hystera*, 'the womb') derives its name from an ancient but erroneous notion that it is specially connected with disorders of the womb. It is a disease which exhibits itself under so many aspects that to describe all the varied forms which it may assume would be to give an epitome of the symptoms of nervous diseases in general, for there is hardly one of these which the mimicry of hysteria may not reproduce. In dealing with the condition two things must be kept in mind—the tendency or temperament which predisposes to it, and the exciting cause which determines the actual attack. Among savages it is scarcely ever met with. Among civilised races it is unequally distributed, the French, for example, being more hysterical than the English, while in every country the female sex, especially at or before the age of puberty, is far more liable to it than the male. Among boys, however, it is not uncommon. The tendency seems sometimes to be due to hereditary influence, sometimes to injudicious training in childhood. The exciting cause which develops the hysterical tendency into actual hysteria is generally some severe emotional shock—a fright, an unhappy love affair, or a sudden reverse of fortune. But many general diseases occasionally carry hysteria in their train; and in 1889 a volume of nearly 400 pages appeared (*The Exciting Causes of Hysteria*, by Georges Gaiñon) dealing solely with the enumeration and discussion of the exciting causes of this Protean malady. In the developed disease some of the symptoms are continuous, others occasional or paroxysmal. The will is weakened, and the patient is a prey to unregulated whims and impulses. The temper is often irritable, and every petty annoyance is exaggerated into a serious trouble. There is a morbid craving for sympathy, which leads to the most outrageous acts. Blood has been swallowed by a hysterical girl in order that she might vomit it again. Porter has been mixed with urine, and



Common Hyssop
(*Hyssopus officinalis*).

the mixture palmed off upon the medical man as an abnormal discharge. The most elaborate lies have been concocted; innocent people have been accused of imaginary crimes; every inconvenience has been suffered and every artifice exhausted in order to play upon the credulity or the pity of friends and attendants.

This moral perversion has its counterpart in the disorder of the sensory and motor mechanism. Sensibility to impressions of various kinds may be exalted, lessened, or abolished. A touch may give rise to all the symptoms of severe pain; and, on the other hand, the prick of a pin, or even the contact of a hot iron, may not be felt. Paralysis of the legs, arms, or face, or of one side of the body, or of special muscles or groups of muscles, is a very common symptom. Laryngeal paralysis may reduce the voice to a whisper. Speech or motor power may often return suddenly, especially under the influence of strong emotion; and there is no doubt that 'miraculous' cures are sometimes of this nature. A hysterical paralytic, for instance, will generally run out of a burning house. Digestive disorders are common in hysteria, and, aided sometimes by fraud, give rise to 'fasting girls' and other newspaper marvels. Palpitation, great rapidity of breathing, giddiness, and flushing of the face are also of frequent occurrence.

But besides these more or less continuous symptoms, there are the occasional paroxysms or 'fits' which in the popular mind are chiefly associated with the name of hysteria. These emotional storms or crises vary much in frequency and severity. In the mildest form there is no loss of consciousness, but the arms, legs, and head are tossed about, and there is great mental excitement. In severer cases, perhaps after some premonitory symptoms, such as the sense of constriction in the throat known as the *globus hystericus*, the patient falls to the ground, sometimes with a scream, her features twitching, her back arched, and her legs and arms moving convulsively. She may snap like a dog at the hands of those who approach her, or at her own, occasionally inflicting serious injuries; but she rarely hurts herself in falling, as often happens in an epileptic fit. The seizure may last only a fraction of a minute, or as long as three or four hours.

The treatment of hysteria must be directed both to the removal or alleviation of the symptoms and to the cure of the condition which gives rise to them. The first object can generally be attained, the second more rarely. The treatment must be both moral and physical, and the former is the more important of the two. In the more severe cases complete change of scene and surroundings is required. The patient should be placed among strangers, and away from the sympathising friends whose well-meant 'coddling' and condolence are often the chief hindrances to recovery. The nurse must be kind but firm; and while the morbid tendencies of the patient are repressed, she must not be laughed at but understood, and encouraged to make essays in self-control. As an alternative to sending the patient away from home, the Weir-Mitchell treatment has met with much success. The patient is kept in bed, isolated except from the attendant, and fed with abundance of easily-digested food, electricity and massage being applied daily.

Particular symptoms must be treated on general principles. Forced feeding by means of a stomach-

tube may be required if the appetite is gone or the patient refuses food. A mixture of milk, eggs, meat, and the flour of lentils has been used for this purpose with success. Of late hypnotism has been much employed in France for the treatment of hysterical affections; but this is a method which should be used with caution, for it sometimes aggravates the condition which it is intended to cure.

For prevention of the 'fits' the most useful drugs are valerianate of zinc, iron, morphia, and turpentine. Slight attacks may be warded off by an antispasmodic like ether, or by inhaling nitrite of amyl. To cut short an attack after it has begun a copious douche of cold water to the head is an old and approved plan. A still more effectual proceeding is to close the mouth and nose with a towel for fifteen or twenty seconds. A little cold water poured into the mouth often acts at once. When everything else fails, $\frac{1}{2}$ th to $\frac{1}{4}$ th of a grain of apomorphine, injected under the skin, will end the fit (Gowers).

People with a tendency to hysteria should be encouraged to substitute some rational and regular work for the aimless life of alternate excitement and lassitude which so many of the women of the upper and middle classes lead.

Hystrix. See PORCUPINE.

Hythe, a parliamentary and municipal borough and market-town of Kent, 5 miles WSW. of Folkestone, 15 miles S. of Canterbury, and 67 SE. by E. of London by rail, is one of the Cinque Ports (q.v.), although in actual locality Lympne or Lynton (the ancient *Portus Lemannis* of the Romans), now some three miles inland, was probably the original harbour. The town, which is pleasantly situated some distance from the sea, is built on the side of a hill, from the top of which an extensive view over the Romney marsh is obtained. Its church, a cruciform building of great beauty, in part Romanesque, has been restored since 1866, and contains in a crypt underneath the chancel an extraordinary collection of human skulls and bones—many of the skulls having deep cuts in them—the age and origin of which are altogether uncertain. Near to Hythe are the headquarters of the School of Musketry and Shorncliffe camp, both established in 1854; the picturesque ruins of Saltwool Castle, with memories of Becket; and the Royal Military Canal, 23 miles in length, constructed in 1805 for the conveyance of military stores to Rye, but never of much use, and now entirely superseded by the railway. In 1881 a sea-wall and parade, extending from Hythe to Sandgate (q.v.) and Folkestone (q.v.), was opened. These and some smaller places are included in the parliamentary borough of Hythe, which since 1832 has returned only one member. Pop. of that borough (1851) 13,164; (1891) 35,547, of whom 4347 were within the municipal limits, which include West Hythe. In 1295 the French made a descent on Hythe, but were decisively repulsed, and later on, towards the end of the reign of Richard II., the town was visited with a threefold calamity, a fire having destroyed 200 houses, a pestilence carried off numerous inhabitants, and an unusually heavy storm caused a severe loss of men and ships. Several charters are preserved at Hythe, amongst them its earliest charter of incorporation granted in 1575. See Montagu Burrow's *Cinque Ports* (1888).

I



the ninth letter in the alphabets of western Europe, was called *iota* by the Greeks, from its Semitic name *yod*. Hence, owing to the character being the smallest in the Hebrew alphabet, we get the word *jot*, 'a tittle' (St Matt. v. 18), and *jottings*, or 'small notes.' The name *yod* meant a hand, the form of the character in the Egyptian Hieratic, from which the Phœnician alphabet was derived, bearing some resemblance to a hand, with the thumb held apart from the fingers (see ALPHABET). In early Greek inscriptions the form of the letter was angular, something like our Z; it then came to resemble S, and this, about the 7th century B.C., was straightened out into a vertical stroke. It has since varied less in form than any other letter. The dot in our minuscule *i* first came into use in the 11th century A.D. It was originally an accent, *i*, and was only employed to distinguish *ii* from *u*, or to mark the *i* in the combinations *ui* and *iu*. In the 12th century the accent began also to be used when *i* was in juxtaposition with *m* or *n*. It only became universal after the invention of printing, when it was found inconvenient to use two forms of type. In the 14th century a dot began to be substituted for the accent, the oldest MS. in which the dot is found dating from 1327. These distinctions may seem trivial, but are very useful in determining the dates of mediæval MSS.

In Italian, and in most European languages, the sound of the letter is that of the Latin long *i*, the name-sound of our *e*, which we have in the English words *machine* and *machine*. The long *i* in Latin was always thus pronounced, and never like *i* in *fine*. The name-sound of our *i*, which is really a diphthong, is only heard in words where it is supported by a subscript *e*, as in *bite*, *pipe*, *aiue*, or where it is followed by an old guttural, as in *high*, *might*, *light*. This became the name sound because the pronoun *i* (A.S. *ie*, Ger. *ich*) was originally followed by a guttural which has now fallen out. The normal sound of *i* in English is that heard in *bit*, *dip*, *sit*, which is the short Latin *i*. This sound is represented by *y* in *equal*, by *u* in *busy*, by *o* in *woman*, by *ei* in *forfeit*, by *ie* in *siere*, by *ui* in *quilt*, by *ie* in *beeches*, and by *ui* in *carriage*. See J.

Iago. See JAMES, and SANTIAGO.

Iambic Verse, a term applied, in classic prosody, and sometimes in English, to verses consisting of two syllables, of which the first is short, and the second long (—). Archilochus (q.v.) is the reputed inventor of iambic verse. The English language runs more easily and naturally in this metre than in any other. Thus, our usual blank-verse line consists of five iambses, while we have also such combinations of continuous rhyming metres in iambic measure as tetrasyllabics; lines of six syllables and three accents (Skeltonical verse); octosyllabics, as in most of the old romances, *Hudibras*, *Lalla Rookh*, and most of Scott's and Byron's romantic poems, except *Lara* and the *Corsair*;

decasyllabics, with five accents, which when rhyming in couplets forms our so-called heroic metre; and Alexandrines, or twelve-syllable metre with six accents, as in Drayton's *Polygobion*. See METRE.

Iamblichus, a Neoplatonist philosopher, a native of Chalcis, in Cæle-Syria, who died about 330 A.D. He was a pupil of Porphyry, and follower of Plotinus; but in his hands the Neoplatonist philosophy degenerated into theurgy and demonology, while among his disciples his reputation spread as a conjuror and miracle-worker. His writings included a life of Pythagoras, and treatises on mathematics and philosophy; the authenticity of the treatise on Egyptian mysteries (ed. Parthey, 1857) is more than dubious. See NEOPLATONISM.

Ianthina, a genus of gregarious, pelagic gasteropods, in the same division as the river snail (*Paludina*), *Trochus*, *Turbo*, &c. The shell is snail-like, but delicate, translucent, and blue in colour. In the warmer seas the animal floats by expanding its 'foot' on the surface, and is drifted about by currents, occasionally on to British shores.



Common 'Violet Snail' (*Ianthina fragilis*): Shell, animal, and raft.

It is most remarkable for an airy raft which it secretes, and eventually sets adrift, laden with egg-capsules, like those of the whelk. The animals exude a violet secretion, and seem to feed on *Volvella* and other Cœlenterates of the Portuguese man-of-war type.

Iapygia. See APULIA.

Ibarra, capital of Iurbabura province, Ecuador, has a pop. of about 10,000.

Ibea, or I.B.E.A. See ZANZIBAR.

Iberia, the name by which Georgia (q.v.) was known to the Greeks and Romans; and also an ancient name for Spain. The question of an Iberian race is discussed at BASQUES, Vol. I. p. 781.

Iberis. See CANDY FLUT.

Ibex, a name given to several species of the genus *Capra*, of which the best known is the Alpine ibex (Ger. *Steinbock*, Fr. *Bouquetin*). The various species are described at GOAT.

Ibis, a genus of birds related to the Spoonbills, and, more remotely, to the Storks and Herons. It comprises about twenty-five species, of which the bulk belong to the Old World, though the genus is nearly cosmopolitan. The bill is long, slender, curved, thick at the base, the point rather obtuse, the upper mandible deeply grooved throughout its length. The face, and generally the greater part

of the head, and sometimes even the neck, are destitute of feathers, at least in adult birds. The plumage is mainly white, with black primary feathers and plumes on the wings. The neck is long. The legs are rather long, naked above the tarsal joint, with three partially united toes in front, and one behind; the wings are moderately long; the tail is very short. The Sacred Ibis, or Egyptian Ibis (*I. aethiops*; formerly known as *I. celestis*), is an African bird, 2 feet 6 inches in length, although the body is little larger than that of a common fowl. The Glossy Ibis (*I.* or *Plegadis falcinellus*) is a smaller species, also African, but migrating northwards into continental Europe, and occasionally seen in Britain. It is also a North



The Sacred Ibis (*Ibis aethiops*).

American bird. Its habits resemble those of the sacred ibis. Its colour is black, varied with reddish-brown, and exhibiting fine purple and green reflections. It has no loose pendent feathers. The White Ibis (*I.* or *Eudicranus alba*), a species with pure white plumage, abounds on the coasts of Florida. The Scarlet Ibis (*I.* or *Eudicranus ruber*) is a tropical American species, remarkable for its brilliant plumage, which is scarlet, with a few patches of glossy black. The Straw-necked Ibis (*I.* or *Carphibis spinicollis*) is a large Australian bird of fine plumage, remarkable for still naked yellow feather-shafts on the neck and throat.

The Sacred Ibis, one of the birds worshipped by the ancient Egyptians, and called by them *Hab* or *Hib*, was supposed, from the colour of its feathers, to symbolise the light and shade of the moon. It was the avatar of the god Thoth or Hermes, who escaped in that shape the pursuit of Typhon. Its feathers were supposed to scare, and even kill, the crocodile. It appeared in Egypt at the rise and disappeared at the inundation of the Nile, and was said to deliver Egypt from the winged and other serpents which came from Arabia. As it did not make its nest in Egypt it was believed to be self-engendering, and to lay eggs for a lunar month. It was celebrated for its purity, and only drank from the purest water; besides which, it was fabled to entertain the most invincible love of Egypt, and to die of self-stayation if transported elsewhere. Its flesh was thought to be incorruptible after death, and to kill it was punishable with death. Ibises were kept in the temples, and unmolested in the neighbourhood of cities. After death they were mummied, and there is no animal of which so many remains have been found at Thebes, Memphis, and some other places. They were prepared as other mummies, and wrapped up in linen bandages, which are sometimes plaited in patterns extor-

nally. See Wilkinson, *Manners and Customs*, and Renouf's *Hibbet Lectures* (1880).

Iblis. See DEMONOLOGY.

Ibn Batuta. Arab traveller and geographer, whose proper name was Abu Abdullah Mohammed, was born at Tangiers in 1304, and spent thirty years (1325-54) of his life in travel. Settling at Fez, in Morocco, in 1354, he wrote the history of his journeys, and died there in 1378. The course of his travels led him first to Mecca, then to Persia, Mesopotamia, Arabia, the east coast of Africa, Asia Minor, the Caspian regions, Khwarizm, Bokhara, Afghanistan, and India; thence he proceeded to China by way of Sumatra, and finally came home to Fez in 1349. But his journeys were not yet done. He visited southern Spain, and then travelled as far as Timbuktu on the Niger. His narrative is extremely interesting, humour and anecdote alternating with graphic description, and through it all runs the golden thread of the writer's naive personality. It was published with a French translation, in 4 vols., by Defremery and Sanguinetti in 1858-59 (3d ed. 1893). See *National Review*, July 1888, and *Sent. Geog. Mag.*, September 1888.

Ibn Gabirol. See AVICEBRON.

Ibn Zoar. See AVENZOAR.

Ibrahim Pasha, viceroy of Egypt (1789-1848). See EGYPT, Vol. IV, p. 242.

Ibrail. See BRAILA.

Ibsen. HENRIK, poet and the creator of a new type of drama, was born at Skien in south Norway, 20th March 1828. In 1842 he was apprenticed to a chemist at Grimstad. But he aimed higher; he studied, and wrote poetry and a drama, *Godlium*. This, published in 1850, was a failure. In the same year he became a student at Christiania University, but soon grew tired of academic study. After nearly two years of journalistic work he was appointed director of Ole Bull's theatre at Bergen. For it he wrote five romantic dramas, but only two—*Lady Ingevald Ostrit* and *The Banquet at Solhøng*—have been published. In 1857 he undertook similar duties for the National Theatre in Christiania. His next dramas were *The Warriors in Helgeland* (1858), *The Rural Kings* (1864), and *Luce's Comedy* (1862). The first two admirably reproduce the style and spirit of the old sagas, and placed Ibsen in the first rank of Scandinavian dramatists. The last is a precursor of his satirical social dramas; it set all the Philistine world of Norway against him. Then in 1862 the National Theatre became bankrupt; and, moreover, Ibsen was bitterly disappointed when Norway held aloof from the Danes in their struggle against the German powers. So, thoroughly disgusted with his countrymen and his country, he said good-bye to Norway in 1864 and lived chiefly in Rome, Dresden, and Munich till 1892, when he returned to Christiania. The Norwegian parliament granted him, reluctantly—a pension in 1866. In that and the following year appeared the lyric dramas *Brand* and *Peer Gynt*, in many respects the finest things he has done; the poetic workmanship is of a very high order. Brand is an incarnation of the absolute sense of duty, but his ideal striving and self-sacrifice end in disaster because he is ignorant of the proper function of love. Peer Gynt is the complete mirror of actual man; in his case self-hood and romantic fancy are the rocks upon which ideal striving comes to nought. By intention peculiarly representative of Norwegian character, both dramas have also a universal validity. In 1873 Ibsen published the double drama *Emperor and Galilee* (Julian and Christ; Eng. trans. 1876), in which he foretells the 'third kingdom' that is to transcend both classic and Christian culture. But already in 1869

he had finished *The Young Men's League*, another of the satirical social dramas which have made his name famous. This has been followed by *Pillars of Society* (1877), *A Doll's House* (1879), *Ghosts* (1881), *An Enemy of the People* (1882), *The Wild Duck* (1884), *Rosmersholm* (1886), *The Lady from the Sea* (1888), *The Master Builder* (1892), &c. The *Digte* (2d ed. 1875) are lyrics and epics.

These plays aroused a storm of controversy in England in 1889, as they had done shortly before in Germany and in the Scandinavian countries. Ibsen is a passionate advocate of individual liberty. He maintains that man's first and chiefest duty is to be wholly man, consistent with himself in all things. An idealist of the highest type in the beliefs he entertains as to the future possibilities of mankind, he is a sceptic in his estimation of existing men, and especially of existing institutions, social and political. His mission, like Socrates' of old, is to awaken men to a real comprehension of themselves. Thus he is an uncompromising moral reformer. He is inspired by a stern Semitic earnestness, and drives right through all obstacles to get grasp of truth unmistakable. The interest and method of his plays are almost exclusively psychological. He makes the consequential development of character the supreme law of dramatic evolution. His plays represent the conclusion from the psychological premises of some problem in character or social circumstance. Each play begins where an ordinary play would be just on the point of ending; the situation is completely formed before the curtain rises. By his analytic method Ibsen is enabled to paint richly-detailed pictures of inner soul-life without resorting to long monologues or explanatory speeches. His language is concise and vigorous, and full of vivid realism. He gets some of his effects by the use of incisive sarcasm and tragic irony and fearless outspoken realism. His characters are real persons: each in thought, language, and behaviour presents a consistent individuality throughout. There is at times too much mysticism and symbolism, and a tendency to exaggerate contradictions of character and overburden the action with motives.

Henrik Ibsen (1858), in commemoration of his 70th birthday, is a collection of opinions, criticisms, and of reminiscences by Scandinavian authors, edited by Gerhard Gran. See biographies by Vasenius (Swedish, 1883), Passage (German, 1883), Jæger (Norwegian, 1888; Eng. trans. 1891), and in G. Brandes' works (Danish, 1883). In English, Mr Gosse's articles (in *Fortnightly*, 1889, &c.); Wicksteed's *Four Lectures on Ibsen* (1892); G. Bernard Shaw, *The Quotations of Ibsenism* (1893); H. H. Boyesen, *A Commentary on the Works of Ibsen* (1894); and Archer's translation of the prose works (1899). Brand has been translated both in prose and verse.

Ibycus. Greek lyric poet, a native of Rhegium, in Italy, flourished about 510 B.C., and lived some time at the court of Polycrates, tyrant of Samos. According to the legend he was slain by robbers near Corinth, and dying called upon a flock of cranes that he saw flying overhead to avenge him. The cranes went and hovered over the theatre at Corinth, where the people were assembled. One of the murderers, seeing them, exclaimed involuntarily, 'Behold the avengers of Ibycus.' This led to an inquiry, and to the conviction of the guilty. The story is best told in Schiller's beautiful ballad. Ibycus wrote chiefly erotic poetry. The fragments that survive are printed in Bergk's *Poetae Lyrici Graeci* (vol. iii.) and in Schneidewin's *Delicatus Poesis Graecorum Elegiacae* (1839).

Ica, a department on the coast of Peru, with an area of 8400 sq. m. and a pop. of over 60,000. The greater part is a sandy desert, but the river valleys are fertile, and are planted with corn, fruits, cotton, and indigo. In one of these valleys lies the capital,

Ica, 50 miles SE. of Pisco, its port, with which it is connected by railway. Pop. 7000.

Icarus. See DEDALUS.

Ice is water in the solid form. It is specifically lighter than water which is just about to freeze, and therefore swims in it. Water, in becoming solid, expands about $\frac{1}{11}$ th in volume or bulk, and thus acquires a density equal to 0.91674 (water at 0° C. = 1.00). The formation of ice takes place generally at the surface of water. This is owing to the peculiarity that, when water has (at the ordinary atmospheric pressure) cooled down to within 3.9° C. of freezing, it ceases to contract as it did before with increase of cold, and begins to expand until it freezes (see HEAT); this causes the coldest portions of the water to be floating always on the surface. In some circumstances, not very well explained, ice forms at the bottom of rivers, and is called ground-ice or Anchor-ice (q.v.).

Water in ordinary cases freezes at the degree of temperature marked 0° on the Centigrade and Réaumur's thermometers and 32° on Fahrenheit's; but if it is kept perfectly still it may be cooled to nearly -5.5° C. below freezing (= 22° F.) and still remain liquid. The least shake, however, or throwing in of a solid body, makes a portion of it freeze instantly, and its temperature rises immediately to 0° C. Sea-water, and salt water in general, freezes at a lower temperature than pure water; in doing this part of the salt separates, and the ice, when melted, gives water that is fresher than that on which the ice was formed. The colour of pure ice is deep blue, which is only discernible, however, when it is in large masses; it is best seen in the clefts of a glacier or of an iceberg. In order to melt a pound of ice it is necessary to communicate to it as much heat as will raise 80.025 lb. of water 1° C. This measures the 'latent heat' of ice; the temperature does not rise until the ice has been melted.

In the neighbourhood of the poles, and on mountains of a certain height in all latitudes, there exist immense masses of permanent ice; and even in some districts of Siberia, where a kind of culture is practicable in summer, there are found, at a certain depth below the surface of the earth, strata of ice mingled with sand. In sinking a well at Yakutsk, the soil was found permanently frozen hard to the depth of 382 feet, and consisting in some parts entirely of ice. In the lower regions of the torrid zone there is no ice, and in the temperate zones it is a passing phenomenon. From

the polar ice-fields and glaciers which are always protruding themselves into the sea, great floating masses become detached and form *icebergs*, *flows*, and *drift ice* (see GLACIER). These bergs or mountains of ice rise some-

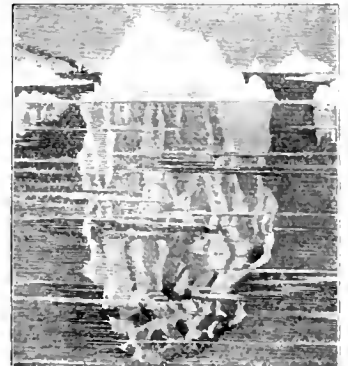

An Iceberg, showing the proportion under water.

times more than 250 feet above the sea-level. They present the appearance of dazzling white chalk cliffs of the most fantastic shapes. Fresh fractures have a green or blue colour. From the specific gravity, it is calculated that the volume of an ice-

berg below the water is about nine times that of the protruding part. Icebergs, and floes or ice-fields, are often laden with pieces of rock and masses of stones and detritus, which they have brought with them from the coasts where they were formed, and which they often transport to a great distance towards the equator. These floating masses of ice are dangerous to navigation. The *ice-foot* is the belt or fringe of ice along the shores in arctic regions.

The hardness and strength of ice increases with the degree of cold. In the severe winter of 1740 a house was built of the ice of the Neva at St Petersburg, 50 feet long, 16 wide, and 20 high, and the walls supported the roof, which was also of ice, without the least injury. Before it stood two ice-mortars and six ice-cannon, made on the turning-lathe, with carriages and wheels also of ice. The cannon were of the calibre of 6-pounders; the thickness of the ice was only four inches, and yet it resisted the explosion.

Faraday first called attention to a remarkable property of ice, since called Regelation. Two slabs of ice, with flat surfaces, placed in contact, unite into one mass even though the temperature of the surrounding air be considerably *above* the freezing-point. Faraday endeavoured to account for this by assuming that a small quantity of water, surrounded on every side by ice, has a natural tendency to become ice; and the fact that two blocks of ice placed in contact do not unite unless they are *most* seemed to bear out this idea. But J. Thomson gave a totally different explanation of this phenomenon. He showed that the capillary force in the film of water between the plates is sufficient to account for a very considerable pressure between them; so that from his point of view the phenomenon would be identical with the making of snow-balls by pressure, or with the formation, by a hydraulic press, of clear blocks from a mass of pounded ice, an observed fact, the explanation of which is to be found in the property of ice mentioned below. Faraday, taking up the question again, showed that the (so-called) regelation takes place in *water* as readily as in air, a fact quite inconsistent with the action of capillary forces. To this J. Thomson replied, showing, very ingeniously, that the capillary forces he at first assumed are not necessary to a complete explanation of the observed phenomena. See *Proceedings of the Royal Society*, 1860-61.

Other views of the question are numerous; for instance, that of Persoz, adopted by Forbes, in which ice was considered as essentially colder than water, and as passing through a sort of viscous state before liquefying, as metals do during the process of melting. This idea, however, has not of late found much support; and it is possible that the true solution of the question is, as J. Thomson pointed out, to be found in the analogy of the crystallisation of salts from their aqueous solutions.

However that may be, there is no doubt about the following property of ice, theoretically predicted by J. Thomson from the experimental fact of its expanding in the act of freezing, and demonstrated by means of the Piezometer by Sir W. Thomson—viz. that the freezing-point of water, or the melting-point of ice, is *lowered by pressure* to the extent of 0.0074 C. for every atmosphere of pressure; and the brothers have, with singular ingenuity, applied this to the explanation of the motion of glaciers. That a mass of glacier ice moves in its channel like a viscous fluid was first completely established by Forbes. Thomson's explanation of this motion is of the following nature: In the immense mass of the glacier (even if it were homogeneous, much more so when full of cracks and fissures, as it always is) there are portions subjected to a much greater

stress than others. The pressure to which they are subjected is such as corresponds to a melting-point considerably *below* the temperature of the mass, and therefore, at such points, if the ice be not altogether too cold it melts, the stress is relieved, and the whole mass is free for an instant to move nearly as a fluid would move in its place. But, the stresses being thus for an instant removed, the temperature and pressure of the water are again consistent with freezing—the thin layer of water quickly solidifies, and then matters proceed as before. Thus, at every instant, the stresses at different parts of the mass melt it at those places where they are greatest, and so produce the extraordinary phenomenon of a mass which might in common language be termed *solid*, and even *rigid*, slowly creeping down its rocky bed like a stream of tar or treacle. This explanation would not meet the case of extremely cold ice; and it appears that even extremely cold ice can be made to flow slowly; whence ice must have some true viscosity.

Ice trade and Manufacture. The trade in ice is now one of great and increasing importance. Ice has always been esteemed as a luxury in warm weather; and this early led to the storing of it in winter and preserving it for summer use. The Greeks, and afterwards the Romans, at first preserved snow, closely packed in deep underground cellars. Nero, at a later period, established ice-houses in Rome, similar to those in use in most European countries up to the present time. But these means were not enough to supply the luxurious Romans with ice for cooling beverages, and they actually established a trade in snow, which was brought to Rome from the summits of distant mountains. The trade in ice in Great Britain was, until a recent period, a very limited one, having been chiefly confined to the supply required by a few of the first-class fishmongers and confectioners—the private residences of the more opulent families being furnished with ice-houses (generally solid built cellars, wholly or partially underground), in which a sufficiency is kept for private use. But ice has come to be more and more largely used in preserving provisions, both in refrigerating chambers and otherwise. It is also used by brewers. In surgical operations ice is used to produce partial anaesthesia; it serves in fevers to cool the mouth and reduce the internal temperature, while ice in bags, applied to the spine, is found helpful in many cases of sea-sickness, and in other applications. Much ice is required in America, during the hot weather, for preserving dead bodies between death and burial.

Ice was imported into England from Norway on a considerable scale as early as 1823; but it was left to the Americans to originate a trade in this article in their own cities, which has extended to Europe and Asia, and in an incredibly short space of time attained a surprising magnitude. The export of ice from America was commenced about 1805, by a merchant named Tudor, who sent ice from Boston to the West Indies. After persevering against many losses he succeeded in establishing a trade with Calcutta, Madras, and Bombay; and now not only is it sent in vast quantities to those places, but also to Hong-kong, Whampoa, and Batavia. About the year 1840 the Wenham Lake Ice Company commenced sending ice to Great Britain from Boston. The supply of ice for Great Britain, however, now comes almost wholly from Norway (mainly from Drobak, near Christiania, where a lake was christened 'Wenham Lake,' after the Boston one; in 1888, 283,605 tons (value £178,482) were imported thence, and only 145 tons from all other countries. In 1896 the export from Norway to Britain had a value of £262,298. In severe winters the Norfolk Broads supply a quantity,

Thirty years previously America had sent to Great Britain on an average 20,000 tons annually, costing £20,000.

In America the ice harvest is gathered in on an enormous scale and with an elaborate system of apparatus. The ice is cleared from snow by means of an implement called the snow-plane. An ice-plough, drawn by horses, and driven by a man riding upon it, is then made to cut deep parallel grooves in the ice, and these are again crossed by other grooves at right angles, so that the whole of the surface is deeply marked out into small squares, measuring a little more than three feet. A few of these square blocks being detached by hand-saws, the remainder are easily broken off with crow-bars, and floated away to the ice-storerooms, which are usually built of wood, on the borders of the lake or river. Some of these are of vast dimensions, and contain vaults of great depth; the walls are double, sometimes treble, or even quadruple, being altogether as much as four feet in thickness, and having hollow spaces between to render them less heat-conducting. The blocks of ice are covered up with sawdust, a layer being placed between each tier of blocks. Many of these ice-houses are made large enough to hold from 40,000 to 80,000 tons of ice. The quantity of ice harvested in the United States may be guessed from the fact that Philadelphia requires an annual supply of 700,000 tons, New York and the adjoining cities, 1,200,000; while in some states the average consumption per head of the population is 1600 lb. yearly. New York is supplied from the Hudson; Philadelphia from the Schuylkill, Delaware, and Lehigh, as well as from the Kennebec; Boston from Wenham Lake, &c.; and the west from the great lakes. Throughout the States everywhere, except in the extreme north, the manufacture of artificial ice is now largely carried on—in 1890 by 222 factories with 3265 hands.

The building of ice-edifices is still a winter amusement in Russia; and, in the New World, Montreal set the example of an annual ice-carnival, one of the features of which is the building of a great ice-palace, and of ice-monuments of various kinds. Skating (q.v.) is the subject of a separate article. Ice-boating is an exhilarating recreation, pursued on frozen lakes and rivers, especially in America. The Canadian ice-boat or ice-yacht is not so much a boat as a triangular framework of wood, running by means of a sail with the broad end foremost—on three skates or runners, 3 feet long by 8 inches deep. There is but one large sail, usually triangular, fastened to a boom and yard, which may be over 30 feet in length. Such an ice-boat may be steered by the rudder-skate in almost any direction not in the teeth of the wind, and may attain an average speed of thirty or forty miles an hour, and sometimes as much as sixty-five miles. Snow seriously reduces the speed. For means devised for artificial freezing, see FREEZING MIXTURES, and GLACIER VEILS.

Ice Age. See GLACIAL PERIOD.

Iceberg. See ICE.

Iceland is an island in the North Atlantic immediately south of the Polar Circle, which just touches the northernmost point of the island, the Melakkasletta. It lies between 63° 23' and 66° 33' N. lat., and between 13° 22' and 24° 15' W. long. The meridian of Ferro crosses the island in the middle. The distance from Iceland to Greenland is about 250 miles, to Norway 600 miles, to the Faroe Islands about 250 miles, and to Scotland 500 miles. Its superficial area is 40,300 sq. m. (more than a third larger than Scotland); its length from east to west 300 miles, and its breadth from north to south 200 miles. The

whole length of the south coast from east to west is entirely wanting in bays and firths; the coast-line is not, however, straight, but bulges out largely in the middle, and the north coast has an inward corresponding curve. Other parts of the coast, especially the north-west and east coasts, are very much indented by firths and bays, as may be seen from the fact that the circumference of the island, if measured from point to point, is only 900 miles, but the coast line following the indentations would be above 2000 miles. The principal bays and firths of the island are Faxallói, Breiðfjörð (Broad Firth), and Isafjörð (Ice Firth), on the west coast; the Humallói (Bear cub's Bay), Skagafljörð (Ness Firth), Eyafjörð (Island Firth), and Skjalfandahlói (Shivering Bay), on the north coast. On the east coast there are no large firths, but many small ones; the best known of these is Seyðisfjörð (Fry Firth).

Taken as a whole, Iceland may be said to be a tableland about 2000 feet high. In some parts it slopes pretty evenly down to the coast, as is the case on the south side between Eyafjallajökull and Reykjanes. Here is the largest extent of lowland, about 1400 sq. m. The next largest piece of lowland is the Borgarfjörð, which extends to the Snaefellajökull range of hills, and is about 400 sq. m. The firths in the north-west, in the north, and in the east, may be looked upon as so many cuttings in the tableland effected by volcanic and glacial action during former geological periods of the island. In most cases these cuttings are comparatively narrow, and hills rise to about 2000 feet abruptly from the water, ending in steep precipices, which afford breeding-places to an immense number of sea fowl. This is especially the case in the north-west and the east. In the north, and in some parts of the east, there are several broad valleys running from the firths into the interior. Iceland is throughout volcanic, and, according to geologists, it owes its existence entirely to volcanic action. The interior and highest part of the island consists of volcanic tuff; the hills of the east and west consist for the most part of basalt. The whole of the interior is occupied by barren sands, lava tracts, and icefields. The largest of these lava tracts is Odathalraum, about 1200 sq. m. The largest icefield is that of Vatnajökull, about 3000 sq. m., and all the icefields together cover 5360 sq. m. At the south-east corner of Vatnajökull is the highest mountain in Iceland, called Orcafajökull; it is 6426 feet above the level of the sea, and its upper part is covered with everlasting snow or ice; and so are more or less all mountains above 4000 feet, as the snow line is usually at from 3000 to 4000 feet. There are twenty volcanoes which have been active at one time or another since the island was inhabited. The most famous of these is Hecla (q.v.), because its eruptions have been most frequent. There are, however, other volcanoes, such as Laki, near Skapta, which have been the seats of more gigantic eruptions. This volcano threw out in 1783 a lava stream about 45 miles in length and nearly 15 miles in breadth. Such an outpour from one volcano at one time is unexampled anywhere else. The south-west peninsula, Reykjanes, has frequently been disturbed by volcanic outbursts, which have not been confined to the land, but islands in the sea round it have been thrown up or submerged alternately by submarine volcanic action. As a result of this volcanic activity, 2400 sq. m. of Iceland are covered with lava. Many of the ice-hills have been active volcanoes during the last 600 years, such as Orcafajökull and Eyafjallajökull. These ice-volcanoes never throw out any lava, but mud and ashes. The numerous hot springs scattered about the island are also connected with the

volcanic fires; these are in many parts made use of by the inhabitants for cooking and washing purposes. There is great difference in the heat of these springs; some are just warm enough for bathing, others convert their water into steam at a degree far above the boiling point. The most famous of these hot springs is Geyser (q.v.). Earth quakes sometimes do a great deal of damage in various parts of the island, as in 1896.

Many considerable rivers run from the interior either north or south, but none of them are navigable, because of their rapidity. The longest are Thjórsa (Ball River) in the south, Jökulsá a Fjöllum and Skjálfandlufjót in the north, each being above 100 miles in length. Of the numerous lakes, Thingvallavatn in the south and Mývatn in the north are the largest. Of the many pretty waterfalls may be mentioned Gullfoss in Hvíta, Gothafoss in Skjálfandlufjót, and Dettifoss in Jökulsá.

Iceland is not rich in minerals, at least not in paying quantities. There are many sulphur-mines, and some of them have been worked till lately with English capital, but not with profit. Surtarbrandur (lignite) and brown coal are found in many places, as well as iron and lime, but it is very doubtful if it would pay to work them.

The climate of the south of Iceland is somewhat like that of the north of Scotland—i.e. rather wet and changeable, but colder. In the north of the island the climate is drier and colder still. Thunderstorms are rather rare, and usually occur in winter. The winter is mild considering the latitude, but spring and summer are frequently cold. The mean temperature of the years 1884-89 in the north was about 35° F. The greatest peculiarity of the Iceland climate is the varying mean temperature of the same month, the difference sometimes being 27°. This is owing to the arrival or non-arrival of the Greenland ice, which not infrequently blocks up the north and east coasts of the island from April to September.

The only cereal found in Iceland is the so-called mehur (*Elymus arvensis*), a kind of wild oats. Turnips, carrots, cabbages, and potatoes thrive very well, and are now cultivated to some extent. The grasses, both wild and cultivated, however, are the principal product of the island. Of trees there is the birch (*Betula intermedia*), seldom exceeding 12 feet in height, and some willows and juniper bushes; amongst the heather are found crowberries and whortleberries.

The only wild animals are the fox and the reindeer; there are both white and blue foxes. Reindeer were introduced in 1770, and there are still a few herds of them running wild on the hills in the interior; they are of very little use to the inhabitants. Of domestic animals the sheep is the most important; it is usually horned, sometimes even with three and four horns, and has some general resemblance to the black-faced sheep of Scotland. The lambs are weaned about the end of June, and the ewes are milked. Large numbers of them are now exported alive to Scotland and England. The cows are of a small breed, but yield a larger quantity of milk in proportion to their size than most other cows. The ponies are generally about 12 hands, but very strong and sure-footed. Thousands are brought to Scotland every year. The genuine Iceland dog has some resemblance to the Eskimo dog and the Scotch collie. According to the latest statistics there are about 20,000 cattle, 500,000 sheep, and 30,000 ponies in the island. Of birds there are immense numbers, especially of water fowl, the most important of which is the Eider duck (q.v.); it yields large quantities of eider-down, and is almost a domesticated bird in many parts of the island. The ptarmigan is the only game-bird. The most

remarkable bird of prey is the Icelandic falcon, formerly so much esteemed for falconry. Of other birds, the whooper or wild swan may be mentioned; it breeds largely in Iceland. The sea around the coasts is very rich in fish, especially cod and herring; the cod-fisheries have been carried on a long time by the islanders, and now also by the French, who employ annually between 200 and 300 vessels in this fishing. Little attention was paid to the herring-fishing till about 1880, when it was largely developed by the Norwegians, and now also by the Icelanders themselves. Finbacked whales, of late successfully fished by the Norwegians, and seals are also numerous. Many of the salmon and trout rivers are now rented by Englishmen. There are no snakes to be met with throughout the whole island—to cite the whole of the memorable seventy-second chapter repeated by Dr Johnson from Horrebow's *Natural History of Iceland* (Copenhagen, 1750; Eng. trans. 1758).

Iceland was discovered about the beginning of the 9th century by Irishmen or Scotsmen, but they did not make any permanent settlement. About seventy years later it was rediscovered and colonised by Norwegians, who preferred to leave their native land rather than submit to the rule of Harold Haarfager. Many of them had previously settled in the Orkneys, Hebrides, and Ireland; and when they were not safe there from the attacks of Harold, they went to Iceland, and a considerable number of Irishmen and Scotsmen went with them. Ingolf was the first settler. In about sixty years the whole island was inhabited, and an aristocratic republic was formed, the central point of which was the Althing which met every year at Thingvellir. In 1262-64 the Icelanders acknowledged the sovereignty of the king of Norway; and in 1388, when Norway was united with Denmark, Iceland shared the same fate. When, however, Denmark had to give up Norway in 1814, Iceland remained with Denmark, because, it is said, the negotiators of the peace of Vienna in 1814 did not know that there was such an island as Iceland in existence. The Althing continued under the Norwegian and Danish rule with very limited powers till 1800, when it was abolished. In 1874 the king of Denmark gave the island a new constitution, according to which the Althing, which had been reorganised in 1843, obtained legislative powers in all matters concerning Iceland. The king appoints a governor (Landshof-thingi), who, with a small council, carries on the government till 1893 under a secretary for Iceland in Copenhagen. In the year 1000 Christianity was introduced in Iceland, and a century later two bishops' sees, one at Skálholt, the other at Hólar, were established. About the middle of the 16th century the Reformation was introduced in Iceland, and since then all the Icelanders have remained Lutherans. Church matters are now superintended by one bishop at Reykjavik.

The most notable events in the history of Iceland from its union with Norway are a long series of afflictions and calamities, caused by volcanic outbursts, severe seasons, epidemics (such as the black death in 1402, the great plague in 1494, the ravages of the smallpox), and in some cases by misgovernment. The population of Iceland in 1804 was 46,240; in 1880, 72,422; in 1890, 70,927; in 1895, 73,149, though in 1872-95, 9000 emigrated to America. In the 12th and 13th centuries the Icelanders produced more vernacular literature than any other nation in Europe, and from that time love of information has been a distinguishing feature of the Icelanders. At the present day elementary education is so general that a child of ten unable to read is quite an exception, and most of them can write also. There are several schools for children, but for the most part

education is imparted at home. There are two higher schools for general education, and a college at Reykjavik for classical instruction; there are also two other colleges for ministers and medical students. Many farmers are acquainted with two foreign languages. Reykjavik, on the south-west coast, is the capital of Iceland, with about 3000 inhabitants. There are two other villages, Isafjord in the north-west and Akureyri in the north, each with 500 inhabitants. For the rest the population is scattered all round the island on isolated farms. The principal means of support of the Icelanders are the rearing of live-stock and fishing. The chief exports are: live sheep, in 1889 about 60,000; salt mutton, 600,000 lb. annually; wool, 1,200,000 lb.; sheepskins, 20,000; tallow, 60,000 lb.; horses, about 2000; salted cod, haddock, and ling, 14,800,000 lb.; salted salmon, about 40,000 lb.; cod-liver oil, about 1800 barrels; shark-liver oil, 4000 barrels; eider-down, 6400 lb.; and feathers, 12,000 lb. The annual imports are: corn and breadstuffs, 10,971,000 lb.; coffee, 440,000 lb.; ebony, 190,000 lb.; sugar, 1,025,000 lb.; salt, 46,000 barrels; tobacco, 133,000 lb.; spirits, 42,000 gallons; beer, 16,000 gallons; petroleum, 55,000 gallons; coal, 4500 tons; fishing lines and ropes, 55,000 lb. Besides these, timber, iron, cotton goods, and other clothing stuffs are imported. The value of the foreign trade, in 1849 only £168,000, was in 1895 £830,350. There are now import duties on spirits and wines, tobacco, coffee, and sugar. The trade with Iceland was confined to Copenhagen for several centuries, and so is the largest part of it still. Since the year 1854 the trade has been free to all nations, and now it is going more and more to Leith and Newcastle. The only native industry consists in working the wool of the sheep into various articles of clothing; this is chiefly done by the women in winter. The Icelanders make a sort of tweed which they call vatnadal, and this is the principal clothing material of the inhabitants, but is not exported. On most farms there is an old-fashioned loom in which the vatnadal is woven.

See Von Troil, *Letters on Iceland* (1772); Sir George Muekenzie, *Travels in Iceland* (1810); Henderson, *Journal of a Residence in Iceland* (1818); C. S. Forbes, *Iceland: its Volcanoes, Geology, and Glaciers* (1840); Sir Richard F. Burton, *Ultima Thule: a Summer in Iceland* (1875); J. C. Poestion, *Island das Land und seine Bewohner* (Vienna, 1885); and A. Baumgartner, *Island und die Fjoroe* (Freib. i. Br. 1889).

ICELANDIC LANGUAGE AND LITERATURE. The language which is now called *Icelandic* was down to the 13th century spoken all over Scandinavia, i.e. in Norway, Sweden, and Denmark, as well as in the Faroe Isles, Shetland, the Orkneys, the Hebrides, and on the coasts of England, Scotland, and Ireland. It was a sister language to the Anglo-Saxon and Old German. Formerly its name was *Dansk Tungu* (the Danish tongue) or *Norrœna* (the Northern tongue). Its similarity to Anglo-Saxon was so close that the ancient Icelandic authors asserted that the same language was spoken in England till the arrival of William the Conqueror as in Scandinavia. This is the language which the Norwegians brought over to Iceland in the 9th century, and because it is now nowhere spoken but in Iceland, it is called *Icelandic*. The present Danish and Swedish stand in the same relation to it as Italian and Spanish stand to Latin. In Iceland it has undergone so little change that any Icelandic child who has learned to read can read the sagas and songs of the 12th and 13th centuries as easily as an English child can read Shakespeare. There is, however, reason to believe that the pronunciation has been somewhat altered, especially that of the vowels and two of the consonants: the *E* and the *I* have in some words been

softened into *g* and *ð* (th) respectively. The vocabulary, the inflexions, and the grammatical construction have been preserved almost unaltered. The relationship to Anglo-Saxon and English may be seen at a glance, so many words in both languages being quite the same. We will take as instances several names of the body, as Icelandic *hand*, 'hand'; *finger*, 'finger'; *fole*, 'foe'; *bak*, 'back.' And if this is the case with English, it is still more so with Scotch, for generally, where the Scotch differs from the English in pronunciation of a word, it is identical with that of Icelandic. In some cases the consonant has been softened in English where it has remained hard in Icelandic: thus the letter *h* in connection with *s* is a softened form of *k*—e.g. 'shall' is in Icelandic, *shal*; 'shell' is *skel*; 'ship' is *skip*, and instances of this kind might be multiplied infinitely. The Icelandic is an inflectional language, having four cases not only for the nouns but also for each gender of the adjectives, some of the numerals, and the pronouns. With regard to the phonetics of the language, it may be remarked that vowel change (*vandaut*) has been carried further than in any other of the Teutonic tongues. The chief characteristics which distinguish Icelandic from German and English are the ending of the infinitive in a vowel, usually *a*, the suffixing of the definite article, and the passive or middle voice of the verb. To every student of Northern history the question must occur, why this ancient tongue has been preserved in Iceland, and not as well in some other parts of the north which have been quite as isolated as Iceland. We have no hesitation in giving as reason the fact that the Icelanders were the only people who had any literature in it, and always took great interest in that literature. This literature has not merely a philological interest, but even more historical interest, as it contains a full account of the men who left their mark in every corner of Europe, who were, in fact, masters of Europe during the 9th and 10th centuries, and whose language and laws are at this moment important elements of the language and institutions of the English-speaking race. It also throws no obscure light on the beliefs and modes of life of our common ancestors.

The earliest monuments of this tongue are found in the Runic inscriptions of Scandinavia (see RUNES). The remains thus found are indeed very different from the language as it appears in Icelandic literature; there is, however, sufficient similarity to show that the language there employed is really the same. The Runic monuments range from the 8th to the 12th century. The earliest literary productions in the Icelandic tongue are the mythical songs contained in the so-called poetical Edda (q.v.), the collection of which has, we believe erroneously, been attributed to Saemund the Learned, who died in 1133. It is impossible to ascertain how far these songs were brought to Iceland by the Norwegians, though some of them seem to point to a time anterior to the settlement of the island. The only thing we know for certain is, that they existed in Iceland in the later part of the 12th century. The identification of some or all of them with either Norway or the Western Islands is founded on no firmer basis than mere conjecture. These songs may be divided into mythical and heroic songs. The mythical songs contain an account of the gods and giants, the creation of the world and of man, the world-long struggle of the gods with the giants or Titans of the Northern mythology, the day of judgment, or the destruction of the gods, the giants, and the world, out of the ruins of which a new heaven and a new earth are to arise. One of the songs of this collection is the *Havamal* (the Song of the High One, viz. Odin); it is a didactic

poem containing rules of conduct in various situations and views of life. The heroic songs mostly treat of the same subject as the German *Nibelungenlied*. Some of these songs contain the most exquisite expressions of Icelandic poetry. There are several other songs of the same type as the Edda. All these songs are alliterative; their characteristics are simplicity of diction and natural expression. By the side of these popular songs a more artificial poetry was developed by the Skalds (q.v.); here rhyme was added to alliteration, and the expression was so artificial that they could be understood by the initiated only. As the theme of their poems was usually a king or chief, whose heroic deeds they celebrated in their songs, this kind of poetry has been called court poetry. Many of these songs formed the nucleus of the later saga. Either the Skald himself, or another person who had learned his poem, would recite it, give explanations of it, and add further particulars to the life of him whom the poet celebrated, and thus the saga took shape shortly after the celebration of the events in the song. Thus a literature arose without the use of letters.

The runes were used only for inscriptions, not for literary purposes. Some authorities, however, are of opinion that the earliest Icelandic writings were in runes, but, as there is not a single title of such writing left as evidence, the conjecture seems very hazardous. The first Icelandic bishop, Isleif, who died in 1080, introduced the Latin alphabet, and taught young men in preparation for the priestly office. In the beginning of the 12th century another bishop had a school where Latin was taught. Shortly afterwards began that literary activity which made the Icelanders famous. The old prose literature of Iceland consists for the most part of sagas—i.e. tales, both historical and fabulous. They are all more or less in the form of biographies; their authors are for the most part unknown. With regard to the scenes of the sagas, they may be divided into Icelandic sagas, or biographies of Icelanders in Iceland, the sagas of the kings of Norway, and sagas concerning other countries. These sagas give a faithful picture of the life and manners of those times, but chronology is usually their weakest point. The father of Icelandic literature was Ari the Learned (1067-1148). He was the first who began to write down the sagas, most of which had already been formed in the mouth of the saga-teller. The principal works of Ari are the *Landnámabók*, or account of the settlement of Iceland, containing the names, genealogy, and brief accounts of every settler. It is an evidence of very careful research and wonderful memory of the author. No other country in the world has such an account of its earliest history. He also wrote a small book called *Líflingur Íslandanna*, on the history of Iceland down to 1135, and an account of the introduction of Christianity called *Kristni Saga*. All these have come down to us; but he also wrote a larger book on Iceland which is lost, and the lives of the earliest kings of Norway, which are also lost except so far as they may be embodied by Snorra Sturluson (1178-1241), the historian and poet. His best-known works are the prose Edda, or manual of Scandinavian mythology and Icelandic poetry, and the Lives of the Kings of Norway, or *Heimskringla*, down to the death of Sigurd the Crusader (1130). The third name is that of Sturluson's nephew, Sturla Thordarson (1214-84), also a poet and historian. He wrote the *Íslandlinga Saga*, also called *Sturlunga*, a graphic account of the feuds between the chiefs of Iceland in the 13th century, which resulted in the subjection of the island to the king of Norway. He also wrote the life of Hákon the Old, who died at Kirkwall in 1263, and that of his son Magnus. The latter is

now lost except a few fragments. The sagas already translated into English are: *Heimskringla*, *Orkneyinga Saga*, the story of Birni Njal, the story of Gísli the Outlaw, the *Fagafélms Saga*, the *Gunnlaugs Saga*, the *Volsunga Saga*, and several smaller ones.

Besides the sagas and poetry there are also found grammatical essays from the 12th and 13th centuries, astronomical treatises, a guide for travellers to Rome and Jerusalem. A remarkable work appeared in the 13th century called *Konungs Skuggsjá* ('king's mirror'), which contains a philosophical contemplation of life, with rules for conduct under various circumstances and in the company of all sorts of people. The old Icelanders were no less industrious translators than original writers, for they seem to have translated any foreign book that came into their hands. Thus they translated many medieval romances, such as the legends of King Arthur, and these translations are now of great value for the textual criticism of the originals. Among the most remarkable translations of those times is a version of the Old Testament, intermingled with various observations on natural history, compiled from medieval sources. This is perhaps the oldest translation of the Bible in any living language. There are also translations of a great number of homilies, of lives of saints, and legends of the church. The code of laws of the Icelandic republic, called *Grágás* (gray goose), first written down in 1118, affords ample evidence of great skill in legislative enactments, and is well worth studying in connection with the legal history of other Teutonic nations.

Shortly after 1300 the literary productiveness of the Icelanders ceased, except for the writing of annals, which had begun in the preceding century. The principal literary activity of the 14th century consisted in copying and making collections of the labours of former centuries. Many of the sagas have been preserved in these copies only, the originals being lost. The 15th century is almost a blank as far as literary activity is concerned, if we except a few song-writers; yet even then there were some students of the old sagas. About the middle of the 16th century a new turn was given to the literary pursuits of the Icelanders by the introduction of the Reformation. The whole Bible was translated and published in 1584, and many other theological works from Danish and German. In the 17th century the interest in the old literature was reawakened, and many parchments were transcribed. At this time also the collecting of manuscripts began, and they were carried partly to Sweden and partly to Denmark. To the latter country they were taken by the indefatigable collector Arni Magnússon, who died in 1730, after having bequeathed his collections to the university of Copenhagen. There is no doubt that this exportation of the manuscripts was very fortunate for their preservation. From this time the literary treasures of Iceland began to be known abroad; the first to make known the historical value of the sagas was the Icelandic Torfaeus, who died in 1719. Since then there has been no want of diligent and careful students of Icelandic literature both among Icelanders, Scandinavians, Germans, and lately also among the English.

The literary activity of the modern Icelanders is not confined to the study of the old literature alone; there is also a considerable modern literature, though it is comparatively less interesting. Iceland has always been and still is rich in song-writers, especially of a lyrical and religious tendency. To the natural history and the history of the island itself there have been valuable contributions. Considering the population and other circumstances of the island, it cannot be denied

that the Icelanders at the present day compare favourably in respect to literary activity with any other people in similar circumstances.

The best guide to the old literature of Iceland is to be found in the *Fæderdomina* to the *Sturlunga Saga*, edited by Dr G. Vigfusson (Oxford, 1878). See also the *Corpus Poeticum Boreale*, the poetry of the Old-Northern tongue to the 13th century (2 vols. 1885), edited, translated, and illustrated by Vigfusson and Powell. Cleasby and Vigfusson's great Icelandic-English dictionary (1874) is the standard one. There is a list of *Books printed in Iceland*, by Fiske (1890).

Iceland Moss (*Cetraria islandica*), a lichen found in all the northern parts of the world, and valuable on account of its nutritious and medicinal properties. It is collected as an article of commerce in Norway and Iceland. In very northern regions it grows even near the level of the sea; in more southern countries it is found on mountains. It is not uncommon in the mountainous parts of Britain, although not turned to any economic account. In Carniola it is used for fattening cattle and pigs. It grows in extreme abundance in Iceland on tracts otherwise desert; and numerous parties migrate from great distances with horses, tents, and provisions, in the summer months, for the sole purpose of gathering it as an article of commerce and for food. In many places this lichen thickly covers the whole surface of the ground, growing about 1½-4 inches high, and consists of an almost erect Thallus (q.v.). It is of a leathery and somewhat cartilaginous substance. When Iceland moss is used as an article of food its bitterness is first partially removed by steeping in water, after which, in Iceland and other

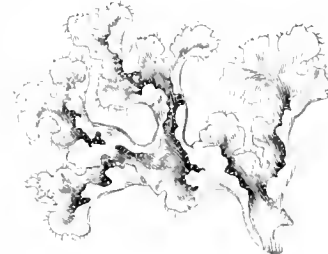

Iceland Moss (*Cetraria islandica*).

northern countries, it is sometimes pounded and made into bread; or it is prepared by boiling, the first water being rejected. It is often boiled with milk, making a kind of jelly, either with milk or water. It is an agreeable article of food, and very suitable for invalids. It contains about 80 per cent. of a kind of starch called *Lichen Starch*, or *Lichulin*, and owes its bitterness to an acid principle, *Cetrarinic Acid*.—An allied species, *Cetraria nivalis*, growing in northern countries, possesses similar properties.

Iceland Spar, transparent calc spar, or calcite, CaCO_3 ; it may be split along its cleavage planes into an obtuse rhombohedron, and is doubly refracting. See CALCITE.

Iceni. See BOADICEA.

Ice Plant (*Mesembryanthemum crystallinum*), an annual herbaceous plant, a native of Africa and of the south of Europe, remarkable for the watery vesicles (*papulae*) with which its whole surface is covered, and which have the appearance of granules of ice, and sparkle in the same manner in the sun. It is common as a tender annual in our greenhouses, and grows in the open garden during summer; the leaves are used for garnishing dishes. The expressed juice of the plant has been greatly extolled as a remedy for diseases of the mucous membrane of the lungs and urinary passages, and also for dropsy. The seeds are used for food in the Madeira Islands. The ashes supply barilla, and the plant is burned on this account

in countries where it abounds. The plant is valuable for extracting soda, potash, and other alkaline salts from unproductive soils, rendering them fit for culture. It is so used in the south of France.

Ichang, a walled town in the Chinese province of Hu-peï, stands on the Yang-tse-kiang, where it escapes from the limestone gorges and ravines of its middle course, and 1000 miles from Shanghai at its mouth. In 1877 it was declared open to foreign trade, but in consequence of the difficulties connected with the navigation of the river, the competition of the Chinese, and the jealousy of the Chinese officials it advanced but slowly. Nevertheless, the net value of the trade notified to the foreign customs-office increased from £21,304 in 1878 to nearly £2,300,000. The imports are chiefly shirtings, lastings, cloth, and silver in ingots, and the exports silk, white wax, drugs, musk, tin, and silver in ingots. The imports from Great Britain constitute about half of the total imports. Ichang is connected with Hankow by telegraph, and so with the outer world. Pop. 35,000. See Little, *Through the Yang-tse Gorges* (1888).

Ich Dien ('I serve'), the motto of Edward the Black Prince, whose badge was a single ostrich feather, afterwards three ostrich feathers. The story that he adopted both motto and badge from John, the blind king of Bohemia, after the battle of Crecy, is not borne out by historical investigation. Since Edward's time the motto 'Ich Dien' and the badge of three ostrich feathers have been employed as the cognisance of the Princes of Wales. See *Diet. Nat. Biog.*, vol. xvii. p. 92.

Ichneumon (*Herpestes*), a genus of digitigrade carnivorous quadrupeds of the family Viverridae, having a much elongated body, small head, sharp muzzle, rounded ears, and short legs. The species, which are pretty numerous, are natives of Africa and the warmer parts of Asia. One, the Andalusian Ichneumon (*I. ichneumon*, var. *Widdringtonii*), occurs in the south of Spain. They feed on small quadrupeds, reptiles, eggs, and insects.



Egyptian Ichneumon (*Herpestes ichneumon*).

Some of them, particularly the Egyptian Ichneumon (*I. ichneumon*) and the Mangouste, Mongoose, or Mongoose (*I. griseus*) of India, have been greatly celebrated as destroyers of serpents and other noxious reptiles, many wonderful fables being superadded to the truth on this subject. The Egyptian Ichneumon, the Ichneumon of the ancients, is larger than a cat, gray, with black paws and muzzle. It was a sacred animal among the ancient Egyptians. The Ichneumon is easily domesticated, and is useful in keeping houses free of rats and other vermin. It is therefore not unfrequently domesticated in Egypt, as the mongoose also is in India. This species is rather smaller, of a lighter colour, and has a pointed tail. Introduced into Jamaica, the mongoose did admirable service in clearing the sugar-cane fields of rats; but became

a plague by destroying poultry and harmless animals.

Ichneumon, a name applied to the members of a very large family of insects (Ichneumonidae), included in the order Hymenoptera, and notable because the larvae are parasitic in, or sometimes on, other insects. There are several thousand species, represented in all parts of the world, including many minute forms and also some of the largest insects. The long antennae have many joints; the abdomen is usually joined to the thorax by a narrow waist; the females are provided with ovipositors, which are in some cases very prominent. With these they lay their eggs in the ova, larvae, or adults of other insects, and sometimes also of spiders. The ichneumon embryos develop in the safe and comfortable hiding-place thus afforded, and utilise their hosts as food for a while, but sooner or later, before or oftener after pupation, leave them dead or dying. Sometimes, curiously enough, the ichneumon themselves fall victims to a similar trick played upon them by members of the same or nearly related families. As adults, these insects feed on the juices of flowers. The parasitic habit of the larvae is sometimes of economic importance, since they thus destroy injurious insects. Thus, *Microgaster glomeratus* and *Pimpla castigator* are parasitic on the caterpillars of the cabbage butterfly, and *Aphidius* upon aphides.

Ichthyology (Gr., 'science of footprints'). See FOSSILES.

Ichor, the ethereal fluid that supplied the place of blood in the veins of the gods of Greek mythology. The name is applied in medicine to the thin watery discharge from a wound.

Ichthyodorulite (Gr., 'fish-spear-stone'), the name given to fossil fish spines, not uncommon in the stratified rocks.

Ichthyology (Gr., *ichthys*, 'a fish,' *logos*, 'a discourse'), that branch of natural history which treats of Fishes (q.v.).

Ichthyornis. See ODONTORNITHES.

Ichthyosaurus (Gr., 'fish-reptile'), a remarkable genus of reptiles which inhabited the sea during the deposition of the Mesozoic strata. Like the modern Cetacea, their structure was modified to suit their aquatic life. The body was shaped like that of a fish, the limbs were developed into paddles, and the tail, long and lizard like, was furnished, it is believed, with a fleshy fin, as in the dolphin, except that its position was vertical. The head was large, and produced into a long and pointed snout, resembling that of the crocodile, except that the orbit was much larger, and had the nostril placed close to it, as in the whale, and not near the end of the snout. The jaws were furnished with a large series of powerful conical teeth, lodged close together in a continuous groove, in which the divisions for sockets, which exist in the crocodile, were indicated by the vertical ridges on the maxillary bone. The teeth were hollow at the root, sheathing the

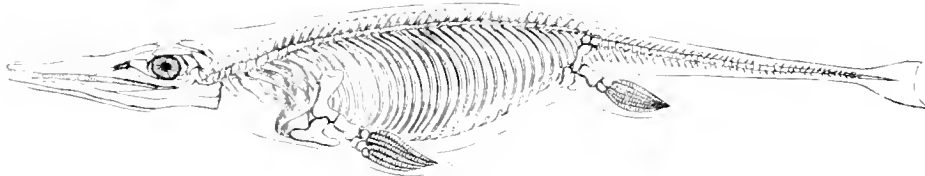

Ichthyosaurus.

young teeth, which gradually absorbed the base of the older ones, and, as they grew, pressed them forward, until they finally displaced them. The long and slender jaws were strengthened to resist any sudden shock by being formed of many thin bony plates, which produced light and elastic as well as strong jaws. The most remarkable feature in the head was the eye, which was not only very large—in some specimens measuring 13 inches in diameter—but was specially fitted to accommodate itself for vision in air or water, as well as for speedily altering the focal distance while pursuing its prey. The structure, which thus fitted the eye so remarkably to the wants of the animal, consists of a circle of thirteen or more overlapping sclerotic bony plates surrounding the pupil, as in birds. This circle acted as a sort of self-adjusting telescope, and, assisted by the extraordinary amount of light admitted by the large pupil, enabled the ichthyosaurus to discover its prey at great or little distances in the obscurity of the night, and in the depths of the sea. The neck was so short that the body was probably not in the least constricted behind the head. The backbone was fish-like; each joint had both its surfaces hollow, making the whole column very flexible. The small size of the paddles compared with the body, and the stiffness of the short neck, seem to suggest that the tail must have been an important organ of motion. Professor Owen is satisfied that it was furnished with a vertical tail, because the vertebrae are compressed vertically, and also because the tail is frequently found disarticulated a short distance from its extremity, as if the weight of the upright tail

had caused it to fall when the animal had begun to decompose. The fish-like body, the four paddles, and especially the powerful tail would make the ichthyosauri active in their movements, and consequently, with their predaceous habits, very dangerous enemies to the other animals that inhabited with them the Mesozoic seas. That their principal food consisted of fishes is evident from the masses of broken bones and scales of contemporary fishes that have been found under their ribs in the place where the stomach of the animal was situated. Not infrequently entire skeletons of small individuals have been found within the thoracic and abdominal cavity of larger ones. As these small skeletons are complete and uninjured and of the same species as that in which they occur, Professor Seeley thinks that some of the ichthyosauri were viviparous.

The remains of ichthyosauri are peculiar to the Mesozoic strata, occurring in the various members of the series from the Lower Lias to the Chalk, but having their greatest development in the Lias and Oolite. More than thirty species have been discovered; they differ from each other chiefly in the form of the head, some having a long and slender snout, like the gaviel of the Ganges, while others had short and broad heads, more like the common crocodile. The great repository for ichthyosaurial remains hitherto has been the Lias at Lyme Regis.

Ichthyosis, or FISH-SKIN DISEASE, is characterised by a hardened, thickened, rough, and almost horny state of the cuticle in severe cases. Instead of exfoliating in fine, almost invisible flakes, it accumulates in irregular scale-like pieces.

which may be removed, but are speedily reproduced. Perspiration is always absent or very deficient in the affected areas. The disease may affect almost the whole surface, or may be confined to a single part; and is most frequently, but not always, congenital. It is attended by no constitutional disturbance, and the general health is often very good. The disease is, however, extremely obstinate, and when congenital may be considered as incurable. Treatment consists in the frequent use of warm or vapour or alkaline baths, so as to soften the thickened epidermis and to facilitate its removal, and friction by means of a piece of flannel or pumice-stone may be conjoined with the bath. The application of sulphur or resorcin to the skin has also the effect of promoting desquamation. The employment of sulphureous baths, such as those at Harrogate, has occasionally been found of temporary use; and the internal administration of tar, cod-liver oil, &c. sometimes gives relief.

Icknield Street (Lat. *Via Ikeniana*), an ancient Roman road of Britain, which ran from Norfolk south-westwards to the vicinity of Land's End.

Icolmkill. See IONA.

Icon Basilike. See ETKON.

Iconium, an ancient town of Asia Minor, situated on the western edge of the plateau that skirts the northern slopes of the Taurus Mountains, 310 miles E. of Smyrna. The capital under the Romans of Lycaonia, it was three times visited by St Paul, who founded there a Christian church. In 708 it fell into the hands of the Arab conquerors. Its prosperity culminated in the end of the 11th century, when it was made the capital of the Seljuk empire. In 1190 Frederick Barbarossa defeated the Turks in the neighbourhood, and captured Iconium. Some fifty years later its sultans were made the political playthings of the Mongols; and in 1392 they submitted to the suzerainty of the Ottoman Turks, though the state was not incorporated in the Ottoman empire until 1486. Being the meeting-point of some of the principal highways of Asia Minor, and a place of considerable trade, it failed not to figure prominently in the wars of the Turks. In 1832 Ibrahim Pasha defeated the Turks there.—The modern town, called KONIEH or KONIYA, the capital of the Turkish vilayet of Konieh, is a place of 20,000 or 30,000 inhabitants, who live by commerce, by making stockings and gloves, and on the contributions of the numerous pilgrims who visit the sacred tombs and other holy places of the town. Here is the principal monastery of the Mevlevi or 'dancing' dervishes in the Ottoman empire. Numerous ruins of mosques, madrasas (colleges), &c. attest the decayed splendour of the place.

Iconoclasts (Gr. *eikon*, 'an image,' and *klazō*, 'I break'), the name used to designate those in the church, from the 8th century downwards, who have been opposed to the use of sacred images (i.e. of statues, pictures, and other sensible representations of sacred objects), or at least to the paying of religious honour or reverence to such representations. The iconoclast movement had its commencement in the Eastern Church. Opinion is divided as to the origin and antiquity of the practice of image-worship (q.v.) in the church; but it is certain that in the 6th or 7th century it prevailed extensively, especially in the eastern empire, and that practices existed in some churches which were a source of much suspicion, and even of positive offence. Many bishops interposed to correct these abuses; but the iconoclast movement, strictly so called, began with the imperial edict issued in 726 by the Emperor Leo III., surnamed the Isaurian, forbidding the honours paid to sacred images, and

even commanding the removal from the churches of all images, that of our Lord alone excepted. This was followed by another decree in 730, which prohibited, under pain of death, as sinful and idolatrous, all acts of reverence, public or private, to images, and directed that wherever such images should be found they should forthwith be removed or destroyed. The attempt to enforce this decree aroused great opposition, especially in the Greek islands and in Italy. The popes Gregory II. and Gregory III. protested vehemently against it, repudiated the imputation of idolatry, and explained the nature of the honours to images for which they contended. Leo persevered, nevertheless, in his opposition, which was continued by his successor, Constantine, surnamed Copronymus. Under this emperor a council was held in Constantinople in 754, in which the iconoclast decrees were affirmed in their fullest extent; and Constantine's son, Leo IV., renewed, on his accession in 775, the enactments of his predecessors. Under the widow of Leo, the Empress Irene, a council was held at Nicea (787), in which these proceedings were condemned and revoked; but other succeeding emperors, Nicephorus (802-811), Leo V., the Armenian (813-820), Michael II., the Stammerer (820-829), and Theophilus (829-842), returned, with greater or less severity, to the policy of the iconoclast emperors. As regards the Greek Church the controversy may be said to have been finally settled under the Empress Theodora in a council held at Constantinople in 840, or at least by a subsequent one of 870. The modern usage of the Greek Church permits pictures, but rejects gilded or sculptured representations of sacred objects. Except in Italy, the iconoclast controversy created but little sensation in the Western Church until the movement in the time of Charlemagne and his successors, to be noticed under the head IMAGE-WORSHIP.

Iklinus. Of Ictinus, who shares with Callicrates the glory of having designed the one perfect building which the world has ever seen, very little can be stated with certainty. In addition to his masterpiece, the Parthenon, the temple of Apollo Epicurius at Bassæ, near Phigalia, the sculptured reliefs from which are now in the British Museum, may be ascribed to him. He is also known to have been the architect of a temple at Eleusis, and to have written an exhaustive treatise upon the Parthenon, with which his name is indissolubly connected. See ATHENS.

Ida, a mountain-range in Asia Minor, extending from Phrygia through Mysia into the Troad. The city of Troy was situated at its base. It is the scene of many ancient Greek legends. The southern part of the range was called Gargarus, the highest peak of which is 5749 feet above the sea. Here there was a temple of Cybele, who therefore was called the *Idæan Mother*. From Ida flow several famous streams, as the Granicus, Simois, and Scamander. There is another Ida (8055 feet) in Crete, extending from west to east, now called Psiloriti. Here Zeus was said to have been educated.

Idaho, since 1890 one of the United States, is situated between the 42d and 49th parallels of latitude, and mainly between the copyright 1900 by J. B. Lippincott 111th and 114th meridians of Company. longitude. In shape it is an irregular trapezoid. Its maximum length is about 490 statute miles; its breadth varies from about 12 miles at the 'pan-handle' which forms the northern part, to 300 miles along the southern boundary. Its area is about 84,800 sq. m.

One of the main ranges of the Rocky Mountains, in various parts called the Cabinet, Cœur d'Alene,

and Bitter Root mountains, forms the north-eastern boundary, separating Idaho from Montana. In the southern part this range is a portion of the continental divide between the Atlantic and Pacific oceans. About 70,000 sq. m. of the territory is situated in the drainage basin of the Columbia River; the remaining part lies in the Great Basin, its surface waters flowing into Great Salt Lake.

A comparatively small area in the south excepted, the entire surface is rugged and mountainous. In addition to the high range on the north-eastern border spurs of this range traverse the territory in a direction generally east and west. Of these Salmon River Mountains are perhaps the most noteworthy, as they separate what is popularly known as Northern Idaho from the plateau region in the central and southern part. All these ranges are high, their summits reaching elevations of 10,000 feet and upwards. The average altitude of the territory is about 5000 feet. The lowest level is the valley of Snake River, which at Boise City is 2000 feet above the sea-level. In the south are a number of irregular ridges largely shaped by erosion, locally known as the Bear River Mountains, Goose Creek Mountains, South Mountains, Black-foot Range, &c. A part of the plateau-region is included in the great lava flood which occurred in comparatively recent geological times, and which is still noticeable in the cliffs and mesas that diversify the surface.

Snake River—also known as Shoshone, and as Lewis River—drains by far the largest part of the territory. Its course (about 850 miles in length) lies in a valley remarkable for scenic beauty. In various places the valley widens out into broad savannas susceptible of a high degree of cultivation. The open valleys alternate with narrow cañons through which the river flows in dalles and cataracts. This river is navigable from the mouth of Powder River to Salmon Falls, a distance of 200 miles. Salmon River, one of the largest tributaries of Snake River, drains the central part. The character of its valley is much like that of the latter. Clearwater, Payette, Boise, Weiser, Buneau, Malade, and Goose rivers are tributaries, important mainly for the fertile lands which flank their courses. Pend d'Oreille, or Clarke's Fork, drains Northern Idaho. Its main tributaries are Coeur d'Alene and St. Joseph rivers. Dalles, cascades, and cataracts characterise all the rivers of the territory. Shoshone Falls almost rival those of Niagara in grandeur.

There are two lake-regions; one in the panhandle, the other in the south-east. The former includes Pend d'Oreille, Coeur d'Alene and Kamiks lakes; the latter, John Day and Bear lakes. The surplus waters of Bear Lake flow through Bear River into Great Salt Lake. These lake-regions abound in game, and are perhaps the finest hunting-grounds in the United States.

Among the wild animals are the grizzly bear, two species of brown bear, the black bear, raccoon, panther, badger, wolf, fox, and coyote. Fur-bearing animals are represented by the lynx, mink, and beaver. The bison, once common, is now rarely if ever seen. The moose and elk are occasionally met with. Deer of two species and antelope are numerous. The Rocky Mountain sheep is found in the Coeur d'Alene Mountains.

Vegetation is abundant in the northern and central parts, but somewhat deficient in the arid lands of the south. Forests of conifers, including white, yellow, black or lodge pole, and sugar pine, as well as several species of cedar and spruce, cover the western slopes of the Bitter Root and Coeur d'Alene mountains. These forests embrace a wealth of timber not surpassed by any other equal area on the continent. Fir, tamarack, and larch

are also abundant. In the central and southern part the forests give place to extensive mesas overgrown with sage brush, and rolling lands covered with bunch grass. The river valleys are dotted with occasional groves of cottonwood and thickets of wild fruits, such as the blackberry, wild currant, salal, and fox grapes.

The mineral wealth of the state consists chiefly in its mines of silver, lead, gold, and copper, productive in the order named. The output of these metals has sometimes reached nearly \$20,000,000 in a year. Coal of good quality has been discovered in seven of the eighteen counties. In the basin region of the south-east soda, gypsum, sulphur, and minerals common to lacustrine deposits abound. Mineral springs are numerous.

The climate is exceedingly healthy. The extremes of temperature rarely range beyond 0° and 90° F., except in regions of great altitude. The rainfall, abundant in the north, is deficient in the south, so that irrigation is necessary to ensure full crops. The agricultural products, stock and farm, aggregate well over \$10,000,000. Grain farming is of necessity confined to the narrow river-valleys, and, as a whole, the territory is better adapted to stock-raising than to cultivation. The crops are largely moved by wagon-trains and river-boats, but there were in 1890 about 1000 miles of railway.

Idaho, constituted a territory in 1863, received its present limits in 1865, and in 1890 was raised to the rank of state. Gold was first found in 1852, and raised in paying quantities in 1860. The population, distributed mainly along the river-valleys of the south and west, was returned at 14,999 in 1870, and 32,610 in 1880; in 1890 it was 84,385, about one-fifth consisting of people of the Mormon faith. There are also upwards of 10,000 Indians not included in the foregoing numbers. The public schools and religious and charitable institutions are well supported.

Boise City, the capital and largest city, had in 1890 a population of 2311. Montpelier and Weiser came next in size.

Iddesleigh, EARL OF, Conservative statesman, better known as Sir Stafford Northcote, was born of a very old Devonshire family, on 27th October 1818, and was educated at Eton and Balliol College, Oxford, gaining a first-class in classics. He began public life in 1842 as private secretary to Mr Gladstone, who was then President of the Board of Trade. In 1847 he was called to the bar, and four years later succeeded his grandfather as eighth baronet. He was secretary to the commissioners of the Great Exhibition, and for his services was created a C.B. In 1855 he entered parliament as Conservative member for Dudley, and in 1858 was elected for Stamford, in 1866 for North Devon. He sat for the latter constituency until 1885. He was Financial Secretary to the Treasury in Lord Derby's ministry of 1859, and in 1866 he was appointed by the same prime-minister President of the Board of Trade. He had already demonstrated his knowledge of finance by his treatise entitled *Twenty Years of Financial Policy*, published in 1862. While at the India Office in 1868 Sir Stafford Northcote was charged with the responsibility of the Abyssinian Expedition, which under his auspices was carried to a successful issue. In 1871 his old ally Mr Gladstone appointed him British Commissioner to the United States for the adjustment of the Alabama difficulty. Sir Stafford Northcote was Chancellor of the Exchequer in Mr Disraeli's ministry of 1874, and among other useful measures which he introduced, in addition to his budgets, was the Friendly Societies Bill of 1875. In the debates on eastern affairs and the Suez Canal he rendered signal service to the government. When Mr Disraeli went to the Upper House Sir Stafford

succeeded to the leadership in the Commons, and his task was very arduous in connection with the Irish debates. Upon the death of Lord Beaconsfield he became joint leader of the Conservative party with the Marquis of Salisbury. His management of the Tories in the Lower House during several years of opposition elicited warm eulogiums. When Lord Salisbury came into power in 1885 Sir Stafford Northcote was raised to the peerage, under the title of Earl of Iddesleigh and Viscount St Cyres, and was appointed First Lord of the Treasury. He sat as chairman of the committee appointed to inquire into the depression of trade. In 1886 he was the recipient of a handsome testimonial, subscribed by members of both political parties. In Lord Salisbury's second ministry Lord Iddesleigh was Foreign Secretary; but he resigned this post early in January 1887. On the 12th of the same month he died very suddenly at the premier's official residence in Downing Street. Lord Iddesleigh was elected Lord Rector of Edinburgh University in 1883, and during his tenure of office delivered an excellent address to the students on 'Desultory Reading.' See his collected *Lectures and Essays* (1887), and the Life by Andrew Lang (1890).

Idea. This word has borne very distinct meanings in the history of philosophy. Down to the 17th century it had the signification given to it by Plato, and referred to the Platonic doctrine of eternal forms existing in the Divine mind, according to which the world and all sensible things were framed. The word was used in this sense in literature as well as in philosophy down to the 17th century, as in Spenser, Shakespeare, Hooker, and Milton.

In speaking of the mental representation of external things, Descartes, instead of employing the various terms *image*, *species*, *phantasm*, &c., which had been the words formerly in use for that particular signification, used the word *idea*. In this he was followed by other philosophers, as, for example, Locke, who states that he has adopted the word to stand for 'whatever is the object of the understanding, when a man thinks.' Thus, the mental impression that we are supposed to have when thinking of the sun without seeing the actual object is called our *idea* of the sun. The *idea* is thus in contrast with the sensation, or the feeling that we have when the senses are engaged directly or immediately upon the thing itself. But the word has been very variously used, as by Berkeley, Hume, Kant, Hegel (see these articles). For innate ideas, see COMMON SENSE, LOCKE.—*Idealism* is a term used almost as variously as *Idea*. Idealism may be a theory concerning our knowledge of external existence, restricting mind directly to knowledge of its own state, whereas the opposed *realism* implies a direct knowledge of the external. Idealism may be also a theory as to the nature of the universe, and be spoken of (rightly or wrongly) as *subjective* idealism, as in Fichte (q.v.), *critical* as in Kant (q.v.), or *absolute* as in Hegel (q.v.). See also BERKELEY. In the mediæval controversies between nominalism and realism, realism was a kind of idealism (see NOMINALISM). Idealism is also used for ethical and æsthetic systems which adopt an ideal standard of estimating character, human possibilities, or subjects in art (see REALISM). The word realism has a further peculiar sense in Herbart (q.v.).

Ideler, CHRISTIAN LEOPOLD, astronomer and chronologist, was born 21st September 1766, near Pehleberg, in Prussia, and, after holding various offices, received a professorship at the university of Berlin in 1821. He wrote several valuable works on chronology, and died August 10, 1846.

Ides. See CALEND.

Idiocy is defined by Ireland as 'mental deficiency or extreme stupidity depending upon malnutrition or disease of the brain occurring either before birth or before the evolution of the mental faculties in childhood; while Imbecility is generally used to denote a less decided degree of such mental incapacity.' The difference between both conditions and *dementia* (see INSANITY) is that the dement was once sane and responsible, the idiot and the imbecile never developed mental capacity at all; they remained arrested children. The name *amentia* has been given to idiocy. The mental faculties never showed themselves in any high degree, because the organ of mind in the brain never developed. There are great varieties of idiocy and imbecility. Some of the lowest have no speech, no power of distinguishing between one person and another, no affection or hatred, no feelings of pleasure or pain, no power to take care of themselves, and can never be taught any of these things. In body such idiots are dwarfish, misshapen, ugly, with the features and expression of face often of the lowest of the lower animals, with no power of walking. This being the condition of the lowest varieties, they rise gradually in the scale till many imbeciles are beautiful in features, and reach normal bodily development, but are slightly wanting in some essential mental faculty, in intelligence, or in affection, or control, or self-guidance. The mental deficiency is in by far the majority of idiots and imbeciles accompanied by corresponding bodily weaknesses of some sort.

Idiots and imbeciles differ much in their capacity for further development under even favourable circumstances. Some can be greatly elevated towards the standard of average humanity, and can even be rendered fit to earn their own livelihood in simple trades or manual labour, while others cannot be in any way improved. They are especially subject to certain bodily diseases of degeneration, such as scrofula, consumption, rickets, and diseases of deficient nutrition generally. Two-thirds of idiots die of consumption. The great aims in treatment are to improve the bodily nutrition, the nervous and muscular action, and the habits, to teach co-ordinated movements and simple employments, such as gardening, mat making, carpentering, &c., and to evolve the possible intelligence by an education through the senses. Some of them have one faculty or capacity fairly or even extraordinarily developed, while the general mental power is weak. Some are good musicians. Some can calculate well, while others are ingenious in constructiveness. Such faculties have in those cases to be especially cultivated. For this purpose good food, exercise, drill, warmth, fresh air, and music are necessary, and a careful study and testing of each case to find out its strong and weak points; and teachers who devote themselves to this particular kind of educative process are required. For most of them this can only be done in Training Schools for Idiots and Imbeciles, of which there are about twelve fully equipped in the United Kingdom. It is felt by many persons that in addition to these a kind of school is needed between them and the ordinary school, for the purpose of developing 'backward children,' of whom there are a considerable proportion in our schools—a deadweight on our teachers and on the progress of the ordinary scholars. Education should be suited to the educability and the inherent brain capacity of the scholar. Congenital idiots and imbeciles may have *attacks of acute insanity*, for which they may need to be sent to asylums for the insane; but as a general rule such institutions are not suitable for them. Few benefactors of their kind deserve more honour than the pioneers in the right treatment and education

of idiots and cretins, such as Reubl, Howe, Seguin, and Guggenbuhl. Few things must have looked so disheartening, unattractive, and unpromising of good results. But from a scientific point of view, both psychologically and physiologically, the undeveloped minds and bodies of this class have great interest and high importance.

Ireland classifies idiocy into ten divisions: (1) Genetous, (2) Microcephalic, (3) Eclampsic, (4) Epileptic, (5) Hydrocephalic, (6) Paralytic, (7) Cretinic, (8) Traumatic, (9) Inflammatory, and (10) by deprivation of the senses. From this it is seen that there are many pathological causes of the disease. It is a popular error to suppose that all idiots have small heads. Three-fifths of them have larger heads than average men, and only a few (the microcephalic) are small-headed. It is quality more than quantity of brain that counts for mind. *Cretinism* is a very interesting variety of idiocy and imbecility, and is the subject of a separate article. The general causes of idiocy have not yet been fully made out. It is unquestionably hereditary in at least 50 per cent. Consanguine marriages are the cause of idiocy beyond doubt, but only when the stock is bad, and so any tendency to nervous disease in the parents is doubled in the children. Scrofula is another fertile source of this degeneration of humanity, and there is ground to believe that frights to the mother when pregnant cause a small proportion of the idiocy of the world. But idiots are born in apparently perfectly healthy families. Evolutionally idiocy, imbecility, and cretinism may be looked on as reversions to a lower type, and so an example of one of nature's ways of bringing a bad stock to an end by stopping reproduction. Idiots and imbeciles are regarded as children all their days by the law, and provisions are made for the appointment of tutors and curators for them. They are held irresponsible for their acts. See Dr W. W. Ireland, *Idiocy and Imbecility* (1877).

Idiosyncrasy. See ANTI-PATHY.

Idle, a town in the West Riding of Yorkshire, near the Aire, 3 miles N. by E. of Bradford, like which it is a seat of the woollen manufactures. Pop. of township (1851) 7118; (1891) 14,462.

Idocrase. See VESUVIAN.

Idolatry is the worship paid to an image which is held to be the abode of a superhuman personality. It is widely spread among primitive religions, as the ideas underlying it form an essential part of the savage philosophy of the universe everywhere. Yet it is not itself a primitive worship, being absent among Bushmen, Hottentots, Fuegians, Veddas, and Eskimo, while present in the great civilisations, as the Egyptian, Chaldean, Indian, Greek, and Roman, and nowhere in more splendid development than in the Mexican and Peruvian. The idol, as something visible and concrete, helps the savage to give a definite form to his vague ideas of higher beings, just as the doll embodies to the child the notion of distinct personality. We may dismiss the idea that idolatry represents a decadence of the religious sentiment, degenerating from a conception of the Divine as absolute spirit to its symbolical representation under human or animal forms. In reality it marks a stage of progress in religious growth, when man rising above the vague adoration of personified objects, conceives of gods under the form judged most worthy of their habitation. In theological phraseology the term idolatry is often used loosely as covering all forms of worship of seen as opposed to unseen existences, thus including *idolatry*, *deity-worship*, *adoration*, *prostration*, *salute*, and even such forms of worship as *prostration*. The earlier stages of idolatry are *animism*, or the worship of

mere objects personified, and *animism*, or the belief in spirits as distinct from things and accustomed to exercise influence upon the affairs of men. It is incorrect to say that idols invariably begin with being symbolical representations, and are next taken for the image, and lastly for the body itself of the divinity, though forgetfulness of their primitive signification. And all images which represent a superior being and are worshipped are not idols, but only those which are believed to be conscious and animate. Yet the distinction is not precise, and indeed within the range of the same religion the images of the Divinity remain for some animate individualities, actual embodiments of spirits; for others mere symbols, like the Madonna and Child which help to warm the piety of the faithful in Catholic countries, or the photograph which brings a distant mother the more distinctly to the memory of an Australian colonist. In course of time the idol tends to become confounded with the idea of which it was the symbol, hence superstition and delusion ensue; but the missionary's iconoclastic zeal is often as unintelligent as the grown man's indignation at the child fondling its doll. It must not be forgotten that the savage mind is ever prone to confound a subjective relation with an objective one. To make the image of an object for him is to reproduce it, and by means of the portrait he passes easily to the notion of reaching its original.

There is a continuous transition from fetichism to idolatry, and the one is commonly the antecedent of the other. Fetichism is strictly the belief that the possession of an object can procure the services of the spirit lodged within its interior, and hence any material object is capable of being made a fetich, provided only it is capable of being appropriated. Naturally the fetich of stone or wood is the one most easily transformed into an idol, and early it is carved, shaped, and polished, like the Greek *xoanon*, or ornamented with coloured feathers or the like. A new step is taken when on the summit of the stone or column there is shaped a human head, like the *hermae* of the Greeks; and once the head is formed the rest of the figure follows naturally. Idols are most often more or less artistic imitations of the human form, often made colossal or monstrous to represent added power or dignity; and it is a somewhat striking development of commercial Christianity that there is an active manufacture of these in our own city of Birmingham and elsewhere, to be sent out to India, it may be, in the same ship with the missionaries. To the savage mind the animal is the equal of man, and it is quite natural that it also should become the dwelling-place of a divinity, either in its ordinary form or in mixed human and animal forms, like the monstrous creations of the ancient Chaldeans. But in general the human form predominates in the conception of gods, because the natural anthropomorphism of man attributes to his deities human thoughts and feelings, and thus ends with lending them also a human physiognomy. Even such developments of idolatry as the apotheosis of the phallic emblem and its representation in wood or stone is but a specialised form of the anthropomorphic spirit.

Idols which receive the worship of a nation or a tribe are a simple development of fetiches in human form which belong to individuals. Thus side by side with idols which are the object of public worship we find others that are merely individual or domestic fetiches, like the small figures buried by the ancient Egyptians in their graves, and the *teraphim* which Rachel stole from Laban, and hid in the camel's furniture on which she sat. The worship of the dead may also lead us to idolatry by the same transitions as the worship of spirits,

They form a large and powerful class of spirits; and it is natural that some receptacle should be found for them. Again, the elemental idea that after death the spirit continues to reside in the body, or in some portion of it, as a bone or the skull, explains the philosophy of placing a statue of the dead man beside his grave. The Maori *atua* or ancestral deity deigns to enter his carved wooden image through the incantation of a priest, in order temporarily to deliver oracles. Tiele has shown us that the *nirgalli*, those representations of monsters so common outside the Chaldean palaces, had for their aim to offer alternative dwelling-places to malignant spirits, especially those of diseases.

A striking feature of idolatry is its tendency to revive even under the shadow of purer spiritual ideas. The proneness of the ancient Jews to lapse into the idolatry of the neighbouring races, despite the lofty conception of monotheism which was early grafted by the Semitic consciousness and is still maintained within the wide range of Islam, is paralleled by the modern Brahman return to a practice abhorrent to the ancient Vedic religion, as well as the universal Buddhist adoration of statues and relics of a founder pre-eminent among men for the pure spirituality of his teaching. And even within the range of Christianity itself such fantastic absurdities as winking and weeping statues, and the periodical liquefaction of a saint's blood sixteen centuries old are conceptions in perfect keeping with the devices of an idolatrous priesthood in Polynesia or Central Africa.

See the articles ANIMISM, ANIMALS (WORSHIP OF), FETICHISM, IMAGE-WORSHIP, and RELIGION; the works of Spencer, Waitz, Schultze, Kéville, and Girard de Rialle, *passim*; and particularly E. B. Tylor's *Early History of Mankind* (chap. vi.), and *Primitive Culture* (chap. xiv.); and Goblet d'Alviella's admirable study, 'Les Origines de l'Idolâtrie,' in the *Revue de l'Histoire des Religions* (vol. xii. 1885).

Idria, a mining-town in the Austrian crown-land of Carniola, celebrated for its quicksilver mines (discovered in 1497), is situated 1093 feet above sea-level in a deep, cañon-shaped valley, on a river of the same name, 23 miles W. by S. of Laibach. Upwards of 230 tons of quicksilver are produced annually, and about 20 tons of cinnabar (red sulphuret of mercury). Pop. 4984. The miners number 1300; about 1000 of the women are employed in lace making.

Idris, a mythical figure in Welsh tradition, supposed to have been at once a giant, a prince, and an astronomer. On the summit of Cader Idris (q.v.) in Merionethshire may be seen his rock-hewn chair, and an ancient tradition told that any Welsh bard who should pass the night upon it would be found next morning either dead, mad, or endowed with supernatural poetic inspiration. This tradition forms the subject of a fine poem by Mrs. Hemans; the gigantic size of the chair is alluded to in Tennyson's *Geraint and Enid*.

Idrisi. See EDRISI.

Idumaea. See EDOM.

Idna, or IDNA, the name of a goddess of the northern mythology. She was the daughter of the dwarf Svadd; but being received among the Æsir, she became the wife of Bragi. See SCANDINAVIAN MYTHOLOGY.

Idyll (Gr. *eidullion*, Lat. *idyllium*, 'a little image'; a term generally used to designate a species of poem representing the simple scenes of pastoral life. It is, however, an error to suppose that the idyll is exclusively pastoral; certainly there is no warrant for such a notion in the usage either of the ancients or the moderns. Of the thirty *Eidyllia* of Theocritus not more than one

half are pastoral in their character. After the use made of the word by Tennyson in his *Idylls of the King*, which are epic in their style and treatment, and romantic and tragic in their incidents, it becomes very difficult to say what may not be called an idyll.

Il, a rocky island in the Gulf of Marseilles, crowned by a castle, the Chateau d'Il, which was built by Francis I. of France, and subsequently used as a state-prison. Here were confined, amongst others, Mirabeau and the Duke of Orleans (Philip Egalité), not to mention 'Monte Cristo.'

Ili, a small seaport in southern Morocco, 35 miles S. of Aguilon, ceded to Spain in 1883 in fulfilment of a clause in the treaty signed between the two countries so far back as 1860.

Iggdrasil. See YGGDRASIL.

Iglau (Bohm. *Jihlava*), the second largest town of Moravia, is situated 1703 feet above sea-level, on the river Jglawa, close to the Bohemian boundary, 123 miles NNW. of Vienna by rail. It has some old churches (one founded in 799). Its staple industries have always been the manufacture of cloth and woollen goods; glass and tobacco are also manufactured. It has a large trade in corn, flax, wool, cloth, and timber. Pop. (1880) 12,378; (1890) 23,716. Here in 1436 the Emperor Sigismund signed the Prague Compactata, after which he was accepted as king by the Bohemians. In the Thirty Years' War it was taken by the Swedes and recaptured by the Imperialists.

Igloodik, an island near the east end of the Fury and Hecla Strait in the Arctic Ocean, is the place where Parry passed the winter of 1822-23.

Ignatieff, NICOLAUS PAVLOVITCH, Russian diplomatist, was the son of General Paul Ignatieff, a favourite officer of Alexander II. He was born at St Petersburg on 29th January 1832, and educated in the corps of pages. In 1856 he exchanged from the military to the diplomatic service. In 1858 he induced China to give up to Russia the Amur province; and in 1860, having been appointed ambassador at Peking, he secured for his country from China the southern portion of the Maritime Province lying east of the Amur. Between the two treaties by which Russia thus gained footing on the Pacific, Ignatieff concluded with Khiva and Bokhara commercial treaties advantageous to his own country. In 1867 he was made ambassador at Constantinople, at which court he had represented Russia since 1864. He there acquired considerable influence over the Sultan and amongst the Turkish statesmen. An ardent Pan-Slavist, he is suspected of having intrigued with the Slav states of the Balkans in the interests of Russia. In the diplomatic proceedings before and after the Russo-Turkish war of 1878 Ignatieff took a principal part as Russia's representative. The treaty of San Stefano was principally his work; and he was greatly incensed when it was decided to submit its conclusions for revision to a European conference at Berlin. After Alexander III. came to the throne Ignatieff was appointed minister of the Imperial Domains, and in 1881 succeeded Prince Loris Melikoff as minister of the Interior. In this capacity he endeavoured to stamp out Nihilism by forcible measures, but unsuccessfully. He was dismissed at the end of the year, apparently because of his Pan-Slavist intrigues, and for having shut his eyes to the persecutions of the Jews.

Ignatius, one of the so-called Apostolic Fathers, about whom information is but scanty down to the time of Eusebius, except in so far as may be gained from the much-disputed epistles associated with his name. His birth and education

are wrapped in obscurity, but from the letters it may be inferred that he was not born of Christian parents, but was converted in mature life, and that his earlier life had been such as to fill his later years with remorse and give an unusual intensity to his religious convictions. The name is Roman; the second name, Theophoros, is merely a second name and not a title of honour ascribed to the saint. It was often interpreted as 'the God-borne,' as Ignatius was said to be the child our Lord took in his arms (Mark, ix. 36, 37), but this story was unknown in the early centuries. Eusebius is silent about it, and Chrysostom says distinctly that Ignatius had not seen the Lord. Origen makes him the second of the Antiochene bishops, and in Jerome's revision of the *Chronicon* of Eusebius he is stated to have been, with Papias and Polycarp, a disciple of St John. The usual date for his accession is 69 A.D., and of his martyrdom 107, but all that can be said with certainty is that his martyrdom fell about 110. The letters show that he was condemned to the wild beasts at Antioch, and that he was carried to Rome by a maniple of soldiers merely for the execution of his sentence. On the journey he was joined at Smyrna by representatives from the churches of Tralles, Magnesia, and Ephesus. Here he wrote four letters which are extant; three to the churches whose delegates had met him—the Ephesians, the Magnesians, and the Trallians; the fourth, to the church of the Romans, whither he was journeying. The first three are mainly concerned in enforcing lessons of doctrinal truth and ecclesiastical order; the fourth is occupied almost entirely with the thought of his approaching martyrdom. Next from Troas he wrote three letters: the first and second to the churches of Philadelphia and Smyrna, which he had just visited; the third to Polycarp, bishop of the latter. The general topics treated are the same as in the first three, but special charges are laid upon Polycarp to exhort the brethren at Antioch. We next hear of him at Philippi, as we learn from Polycarp's extant reply to the Philippians, who had evidently asked Polycarp for copies of the letters of Ignatius—not improbably the very cause of their preservation. Beyond this point we know nothing more of Ignatius save that at Rome he earned his martyr's crown. The tragic interest of his journey to face his doom in the arena, and the noble and exalted heroism of his enthusiasm as the vision of martyrdom for his Lord opened up before his eyes, left his dying letters a precious heritage to the church and gave an added sanctity to his teaching.

About the close of the 4th century we meet the persistent statement that the relics of Ignatius had been carried from Rome to Antioch, and we find October 17 fixed as the day of his martyrdom. The bones were finally deposited in the Tycheum or Temple of Fortune, which henceforward became known as the Church of Ignatius. His reputation was great, as is evinced by the epistles forged or interpolated in his name; the legendary acts of martyrdom, which give the unhistorical but well-known interview with Trajan; the translation of his letters into Syriac, Coptic, and Armenian, honoured especially by the Monophysites, who fancied they found support in them for their distinctive tenets. And from the close of the 16th century the Jacobite patriarchs of Antioch have regularly assumed the name of Ignatius on their accession to the see.

The Ignatian epistles exist in three different forms or recensions. The *first* of these contains three epistles alone: to Polycarp, to the Ephesians, and to the Romans. It is extant only in a Syriac version. The *second* presents these three epistles in a fuller form, and adds to them four others: to

the Smyrneans, Magnesians, Philadelphians, and Trallians. Besides the original Greek this form is found in Latin, Armenian, Syriac, and Coptic translations, although only fragmentarily in the last two. The *third* contains the seven epistles already mentioned in a still longer form, together with six others—a letter from Mary of Cassobola to Ignatius, and letters from Ignatius to Mary of Cassobola, to the Tarsians, the Antiochenes, to Hero, and to the Philippians. This recension is extant both in the Greek and in a Latin translation. These three it is now usual to call the *Short*, *Middle*, and *Long* recensions. As will be seen, of the twelve Ignatian epistles (excluding that of Mary to Ignatius) three occur in three different forms, four in two forms, and the remaining five in one form only. The Long recension is now universally condemned as spurious. More serious is the dispute between the remaining two, which are often spoken of, from their editors, as the Curetonian (*Short*) and the Vossian (*Middle*) versions. The Curetonian long held the field, but the genuineness of the Vossian letters is now the prevailing belief, and is every day gaining ground. Bishop Lightfoot began by believing in the Curetonian form, but gradually found that the position demanded too much ingenuity from the Ignatian forger, and at length, influenced greatly by Zahn, found himself compelled to believe in the seven Vossian epistles as representing the genuine Ignatius. Indeed the priority and substantial genuineness of the Vossian letters may be said to be proved, in so far as any question of the kind can be proved, by Lightfoot's work; and with this conclusion one of the main buttresses of Baur's scheme of the formation of the Christian canon and of early Christian history generally falls to the ground.

The Short Form, represented only by a Syriac version, was first published by the Rev. W. Cureton in 1845, from MSS. recently brought to the British Museum from the Nitrian desert. Not only are the epistles fewer in number, but shorter and more abrupt. Their upholders believe the Greek form an expansion and corruption of the lost Greek originals of these Syriac letters; while their opponents think the Syriac an abridgment of the Greek.

The Middle Form was first published in the Latin version (made perhaps by Robert Grosseteste), by Cusshier (Oxford, 1644), from two MSS. discovered in England; the original Greek, by Isaac Voss (Amsterdam, 1646), from a Medicean MS., the epistle to the Romans alone excepted, which was first published by Ruyart (Paris, 1689). The Armenian version appeared at Constantinople in 1783. These may now be accepted with some confidence as the seven epistles of Ignatius mentioned by Eusebius, which were translated into Syriac soon after his time, and of which the Curetonian epistles are merely an extract.

The Long form in its Latin version was printed by J. Faber Stapulensis (Paris, 1498); in the Greek version by Valentinus Paccus (Dillingen, 1557). These epistles are supposed to have been interpolated and extended by the pseudo-Ignatius in the later half of the 4th century.

The chief differences in substance of these three forms of the Ignatian epistles are these: the Curetonian text contains no quotation from the Old Testament, and very few from the New, while the Vossian contains a considerable number of quotations, and the Long a large number. Again, the last also contains many allusions to religious institutions not in existence in a mature state before the 4th century, as well as plagiarisms from preceding writers and perceptible differences in doctrinal teaching. There is a tendency to maintain the supremacy of the Father and to make the Son's agency dependent. Indeed, many passages savour distinctly of Apollinarianism, yet the general bearing of the language leans faintly to the Arian side. The whole might well be an ingenious

palmed off by a pious fraud upon the name of a venerated primitive father of the church. The style and expression throughout drive us to the conviction that the six additional letters come from the same hand which interpolated the seven.

Again, the Vossian letters are found to be distinctly antagonistic to Docetism. Indeed, a characteristic note of Ignatian theology throughout is the accentuation of the twofold nature of Christ—his deity and his humanity. The advocacy of the episcopal office appears definitely in the Short no less than the Middle form; and the abridgment must have been made rather for purposes of edification or practical convenience rather than for Monophysite reasons, as C. Wordsworth maintained, or for any other doctrinal purpose. In short the abridgment theory is much more rational and easy than the expansion theory, and if we are to accept the latter we must maintain, says Lightfoot, that the pseudo-Ignatius was a prodigy of minute observation, of subtle insight, of imitative skill, of laborious care, which is probably without a parallel in the history of literary forgeries, and which assuredly was an utter impossibility among the Christians of the 2d and 3d centuries.

The prominence and authority of the episcopal office in the Ignatian epistles has proved a grave stumbling-block to many scholars. It is certainly sufficiently clear throughout, yet it is merely as the embodiment of the idea of order and the guarantee of unity within the church. It is not upheld exclusively as against other forms, while all tinge of sacerdotalism is absent, as well as such an argument as that in Irenæus, who lays stress on the apostolic succession as a security for its faithful transmission. Nor is it autocratic by any means, while its spread is not yet uniform throughout Christendom, as at Philippi, for example. Evidence of a localised episcopate within the Gentile churches is absent, and nowhere is there any trace of the notion of a distinct diocese, while there is no reference to any developed ritual of public service. Six of the epistles are full of the necessity of obedience to bishops, which is alone wanting in the seventh, that addressed to the Romans, who it may legitimately be inferred had not yet adopted the form of government which Ignatius elsewhere commended with such warmth.

See Cureton, *Antient Syrian Version of the Epistles of S. Ignatius*, &c. (1845), and his *Copius Ignatianum* (1849); the works in his support by Bunsen, A. Ritschl, E. A. Lipsius, and those against his theory by Baur and Hilgenfeld, who denied the authenticity of any recension. A fatal blow to Cureton's theory was dealt by the able and learned work of Zahn, *Ignatius von Antiochien* (1873), which won over Lipsius, and now holds the field, its most formidable champion being the late Bishop Lightfoot, whose work, *The Apostolic Fathers, Part II., S. Ignatius and S. Polycarp* (2d ed., 3 vols., 1889), contains all materials necessary for a complete study of the question, and is a masterpiece of profound erudition and conclusive argument hardly to be equalled in the whole range of English or German scholarship.

Ignatius' Beans. SAINT, the seeds of the *Ignatia amara*, formerly *Stychnium Ignatii*, a tree of the natural order Loganiaceæ, and nearly allied to that which produces *Narcomeia* (q. v.), a native of Cochin China and of the Philippine Islands. The fruit is of the size of a large pear, and contains about twenty brownish seeds, of about the size of olives, rounded on one side, and somewhat angular on the other. They contain *strychnin*, but no larcina, and their medicinal uses are similar to those of *narcomeia*.

Ignatius Loyola. See LOYOLA.

Igneous Rocks are those which have been erupted from the heated interior of the earth: hence they are also termed *eruptive rocks*. Petrologically they may be grouped under two heads—*crystalline* and *fragmental*. The crystalline division includes many rocks which are rather vitreous or glassy than crystalline, while a large number are composed partly of crystalline and partly of non-crystalline materials. No quite satisfactory classification of the 'crystalline' igneous rocks has as yet been possible, perhaps the most convenient being that which is based on the nature of the principal rock forming minerals. Thus, those in which orthoclase (see FELSPAR) is a dominant ingredient are grouped together as *Orthoclase rocks*. In another large class plagioclase felspars play a principal part, and thus we have the *Plagioclase rocks*, and so in like manner *Nepheline* and *Lenticite* rocks, and *Olivine* and *Serpentine* rocks.

(1) *Orthoclase Rocks*.—Some of these rocks contain much free silica (Quartz, q. v.), while others contain little or none. They are thus divided into two groups—*Quartziferous* and *Quartzless*. Under the first group come *Granite*, *Quartz-porphry*, and *Liparite*, while under the second are ranged *Syenite*, *Orthoclase-porphry*, and *Trachyte*. Some of these rocks are holocrystalline—i. e. composed entirely of crystalline ingredients, as granite and syenite; others, such as liparite and trachyte, are only semi-crystalline—they contain in addition to crystalline constituents a larger or smaller proportion of non-differentiated mineral matter. *Obsidian* and *Pebble-stone* are vitreous species of orthoclase rocks which consist almost entirely of volcanic glass. Other kinds of orthoclase rocks have been recognised by petrologists, but those mentioned are the most important.

(2) *Plagioclase Rocks*.—Most of the rocks in this division are distinguished by their basic character—that is to say, they contain generally less silica than orthoclase rocks. The most important species are *Diorite* (a crystalline granular aggregate of plagioclase and hornblende), *Andesite*, *Porphorite*, *Basalt*, and *Gabbro*. The holocrystalline character is seldom met with in this division; it occurs, however, in diorite and gabbro. The other species mentioned usually contain some admixture of non-differentiated mineral matter. Vitreous varieties also occur in this division. See BASALT.

(3) *Nepheline and Lenticite Rocks*.—The rocks included under this head closely resemble the basalt rocks of the preceding division, plagioclase being substituted in whole or in part by nepheline or lenticite or by both. See BASALT.

(4) *Olivine and Serpentine Rocks*.—These are generally rather basic rocks. The olivine rocks proper, or *Peridotites*, as they are called, contain olivine as their principal constituent. They often show more or less alteration, the olivine being replaced in whole or in part by Serpentine. Some olivine rocks, indeed, have been completely altered into serpentine.

The *fragmental* igneous rocks consist of the loose ejectamenta which have been erupted from volcanic orifices. These rocks are frequently consolidated, and when fine-grained it is sometimes



FIG. 1.—NECK FILLED WITH FRAGMENTAL IGNEOUS ROCK.

difficult without the help of the microscope to distinguish them from compact crystalline igneous rocks. Some account of these rocks will be found under AGGLOMERATE, TUFF, VOLCANO.

Igneous rocks, when looked at from the point of view of the student of structural geology, are classified in an altogether different way. It is not only necessary to know the petrological character of a rock—we must discover something of its history. Was it extruded at the surface like the ejecta of modern volcanoes, or did it cool and consolidate below ground? Thus two kinds of igneous or eruptive rocks are recognised by geologists: (1) *Eufœnic rocks*, consisting of lavas, tuffs, &c., which have been ejected at the surface, either upon the land or under water; (2) *Plutonic or Hypogœic rocks*, which, whether consisting of crystalline or fragmental materials, have not been so extruded, but are now exposed owing to the denudation of rock-masses underneath which they were formerly concealed. The volcanic rocks are often termed *contemporaneous*, i.e. they belong to the same geological age as the strata with which they are *interbedded*. On the other hand, the *plutonic* rocks are described as *intrusive* or *subsequent*, because they have been *intruded* amongst, and therefore must be *subsequent* in date to the rocks with which they are in contact.

(1) *Contemporaneous Igneous Rocks*.—These consist of crystalline (lava flows) and fragmental rocks (tuffs, &c.), and are simply the products of former volcanic action. They are met with at all geological horizons from the oldest down to the most recent period. Sometimes they indicate the former existence of small isolated 'puys' (see VOLCANO), from which it may be only a single eruption took place; at other times they are obviously the products of much more powerful and long-continued volcanic action. Many of the hill-ranges of central Scotland (for example, Siddlows, Ochils, &c.) are built up of successive lava flows with associated tuffs, which have been ejected from vents in the manner of modern volcanic eruptions. In some regions, however, there occur vast successions of lava-flows, covering immense areas, which do not appear to have been erupted from isolated vents, but are believed to have welled up along the line of great fissures, and to have poured in wide floods over the surface, so as eventually to form extensive plains or plateaus. The rocks of such 'fissure-eruptions' consist usually of basalt, with basalt tuff or Palagonite. The basalt plateaus of the western territories of North America, of Iceland and the Faroes, of the Deccan (India), and of Abyssinia are good examples; while in Antrim and in many of the western islands of Scotland fragments of similar plateaus may be studied.

An interbedded or *contemporaneous* lava-form rock may often be distinguished from an *intrusive*

vent. These latter, in countries where volcanic action has been long extinct, no longer exist as crateriform hollows. The upper parts of the cones have all been swept away, and only the stumps remain. These stumps are known as *necks*, by which is understood a more or less cylindrical funnel or volcanic vent filled up either with fragmental or crystalline rock or with both. Such necks vary in diameter from a few yards up to several hundred feet; sometimes they occur upon a line of Dislocation (q.v.) or fault; at other times they have no such connection. The necks now described are probably the relics of comparatively small volcanoes like the puys of Auvergne and the Eifel. Now and again, however, as in some of the hill ranges of central Scotland, necks of a larger size are met with. These vary from 100 yards or so up to a mile or more in diameter, and are usually plugged up with crystalline igneous rock, although fragmental rock also is occasionally present. Such necks seem to be the stumps of great volcanic vents, from which the lava-form and fragmental igneous rocks of the surrounding neighbourhood were ejected. Good examples occur in the ranges of the Siddlows, the Ochils, the Braids, &c. *Bosses* is the term applied to irregular-shaped masses of crystalline igneous rocks, which appear to be for the most part of deeper-seated origin than those of the necks just referred to. The rocks of these bosses are usually more or less coarsely crystalline, and often have a granitoid aspect, such as granite, syenite, gabbro, &c. Bosses usually cover a considerably wider area than necks, and it has been conjectured that they are merely the most deeply seated portions of ancient volcanoes—the reservoirs from which molten matter was pumped up to the surface. *Intrusive Sheets* are masses of crystalline

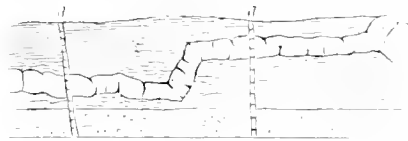

Fig. 3.—Intrusive Sheet and Dykes: *i*, igneous intrusive sheet; *d, d*, dykes; *s, s*, sedimentary strata.

igneous rock which have been erupted between the planes of bedding of pre-existing strata. They are never scoriaceous or slaggy, and are generally markedly crystalline in texture, especially when the sheet is thick. Their intrusive character is often betrayed by the baked appearance of the beds which overlie them; by the fact that they seldom keep quite to one and the same plane, but sometimes break across the overlying beds and continue their course along a somewhat higher horizon; and by the veins and protrusions which not infrequently proceed from them. *Dykes* are vertical wall like sheets of igneous rock, which may vary in thickness from a foot or so up to 30 yards or more. They often run persistently in one direction for many miles. Occasionally they divide into two or more branches, and now and again they send out veins into the surrounding strata. The rock most frequently met with in such dykes is basalt. Sometimes dykes rise along the lines of faults, but this is by no means general. *Veins* is the term applied to the more irregular, winding, branching, and tortuous smaller intrusions of igneous rock. They may consist of any kind of crystalline rock. Dykes and veins are frequently found proceeding in all directions from bosses, as in the case of granitic masses. From the smaller puy like necks also veins and dykes have occasionally been injected into the surrounding rocks, while these and



Fig. 2.—Contemporaneous and Intrusive Igneous Rocks: *p, p*, contemporaneous trap-rocks; *f, f*, contemporaneous fragmental igneous rocks; *i, i, i*, intrusive igneous rocks.

sheet of crystalline igneous rock by noting that the beds which immediately overlie it show no trace of having been subjected to the action of heat. The upper part of the lava-form rock is not infrequently scoriaceous or amygdaloidal (see AMYGDALOID) in character, and fragments of this crust may occasionally be found in the overlying beds if these chance to be of aqueous origin.

(2) *Intrusive Igneous Rocks*. These rocks are likewise met with under two forms, *crystalline* and *fragmental*. The *fragmental* intrusive rocks are found only in connection with old volcanic

extensive sheets may often be traced proceeding from the larger kinds of necks. The rocks surrounding bosses, and traversed by veins, are often highly metamorphosed.

Ignis Fatuus (Lat. *ignis*, 'fire,' *fatuus*, 'foolish') is a luminous appearance of uncertain nature which is occasionally seen in marshy places and churchyards. The phenomenon has been frequently described, but it has been observed so rarely in favourable circumstances by scientific men that there is no satisfactory explanation. The light usually appears in autumn evenings shortly after sunset; it is common in the north of Germany, in Italy, in the south and north-west of England, and on the west of Scotland, but it has been noticed in many other countries.

Descriptions of ignis fatui vary so much that several different phenomena have evidently been included under the name. The light usually resembles a flame, and is often mistaken at first for the light of a lantern, but seen more closely the colour appears as bluish, reddish, greenish or yellowish, merging into purple, but never a clear white. Some observers describe the flame as fixed in position, shining steadily either close to the ground or a few feet above it, and illuminating the surrounding reeds and grass. Others have seen it in motion bounding rapidly over the country, and sometimes rising high in the air. The light has been seen to divide repeatedly into several smaller flames, which describe complicated movements, advancing, retiring, and combining. The moving light is said to recede from an observer who approaches it, but to follow him if he retires from it.

Some supposed appearances of the ignis fatuus have been proved to be the lights of distant houses seen through trees; others are almost certainly due to luminous insects, such as the glow-worm, or to the phosphorescence of decaying vegetable matter. St Elmo's Fire (q.v.) has also been confounded with it. But setting all these possible cases aside, both fixed and moving ignes fatui have been proved to exist. The spectrum of the light has never been observed, so far as the writer can ascertain. It is said that paper has been ignited by the flame, and if this be so there must be at least two similar phenomena of different nature. List in north Germany passed his hand through the luminous appearance and felt no warmth; near the same locality at a later date Knorr held the metal tip of a walking-stick in the flame of a fixed ignis fatuus (which he could not himself touch on account of the marsh) for a quarter of an hour, but the metal was not warmed. In the former instance a puff of air extinguished the flame, and a very slight explosion was heard when it reappeared; in the latter a strong waft of air only made it flicker slightly, and a light breath produced no effect. No odour was perceptible.

The common hypothesis that ignis fatuus is the flame of burning marsh-gas, CH_4 , is untenable, for although this gas is produced abundantly in many marshy places it cannot ignite spontaneously. The more plausible suggestion that phosphuretted hydrogen, PH_3 , which is spontaneously inflammable, might be produced in churchyards or marshes where there is decaying animal matter, does not account for the effect observed by the German physicists, since no gas can burn without giving out heat, and that particular gas has a very penetrating and characteristic smell. Nor could a burning gas, except on the most extravagant assumptions, bound over the country like a ball of fire for half an hour at a time. The early supposition of a phosphorescent vapour is more reasonable, although excepting that of free phosphorus, which would not occur in nature, no such vapour is known

to exist. The phenomenon was undoubtedly more common a century ago than it is now, and its disappearance in many localities may be directly traced to the draining of tens and marshes.

Popular names—e.g. Will-o'-the-Wisp, Jack-a-Lantern, Spunkie, &c.—abound in folklore, and are connected with many stories of travellers mistaking the marsh lights for a cottage window, and being decoyed into dangerous places, often with fatal results. A German legend identifies the will-o'-the-wisp with the soul of an unbaptised infant; an Irish, with a soul broke out of Purgatory. For the folklore of the subject, see *Notes and Queries*, *passim*.

Ignoramus (Lat., 'we do not know'), the word formerly written by a grand-jury on the back of an indictment, meaning that they rejected it. The word is now used most commonly as a synonym for a blockhead.

Ignorance (*Ignorantia juris*) is held in law to be no excuse for any breach of contract or duty, nor for crime or other offence. It is absolutely necessary to start with this maxim, otherwise it would be quite impossible to administer the law; for if once a contrary maxim were allowed it would not only be a premium to ignorance, but would lead to endless and abortive inquiries into the interior of a man's mind. Ignorance of a fact, however, is a different thing. Another kindred maxim of the law is that every man intends the consequences of his own act. Thus, if he shoot at or give poison to a person it is presumed that he intended to kill such person. So, if he leave a trap-door open in a street or thoroughfare it is held that he intended people to fall into it and be injured. There is, however, a doctrine called *bona fides*, which, in the case of petty offences punishable by justices, often tempers the strict and rigid application of the maxim, *ignorantia juris neminem excusat*; and even in crimes a judge always takes into consideration, when passing judgment, whether the prisoner or defendant was an ignorant or intelligent person.—In Catholic theology, a man is never excused for sin, whether of omission or of commission, on the plea of ignorance which he can be fairly expected to overcome, of 'vincible' or wilful ignorance; whereas 'invincible' ignorance, which a man could not help or abate, altogether excuses from guilt.

Ignorantines, a religious congregation of men in the Roman Catholic Church, devoted to the gratuitous instruction of poor children, now better known as the Brothers of Christian Schools. See *SCHOOLS*.

Igalada, a town of Spain, 32 miles NW. of Barcelona, on the west side of Mount Montserrat. It carries on manufactures of cotton and woollen goods and firearms. Pop. 11,900.

Iguana, a genus typical of the Iguanidae, a family of thick-tongued lizards representing in the New World the Agamidae of the Old. The family comprises fifty-six genera, most of which are found in tropical America. They are slender and lizard-like in form, have distinct eyelids, the tympanic membrane usually free, the tail long and compressed, the toes five, five on each limb, and ending in a sharp claw. They are arboreal in habit, and feed chiefly on leaves and fruits, but will also eat insects. The genus *Iguana* includes five species, found in the West Indies and South America, and all characterised by a pyramidal head, a pouch of skin under the throat, and an upright comb of pointed teeth extending along the back from the neck to the tip of the tail. The best known is the Common or Green Iguana (*I. tabourinatus*), which has a very large pouch, is predominantly of a beautiful green colour, and grows to a length of

from 3 to 5 feet. This iguana lives usually in trees near a stream, climbing with great ease, and moving rapidly along the branches, but taking readily to the water, where it swims by means of its tail.

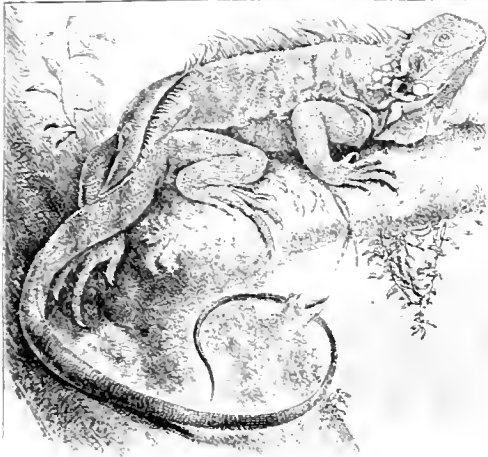

Common Iguana (*Iguana tuberculatus*).

Its flesh is white and tender, and is much esteemed for food. It is sometimes caught by noosed cords, sometimes tracked to its burrow by dogs trained for the purpose. The eggs are about the size of those of a pigeon, but have no hard shell, and are laid in the sand. They also are used as food. Other species of iguana and their eggs are eaten by those, as Darwin says, 'whose stomachs soar above all prejudices.' Other important genera are *Anolis*; *Cyclura*, one species of which, *C. Lophomus*, is called the 'great Iguana' of Jamaica; *Amblyrhynchus*, the marine lizard; *Phrynosoma*, the 'horned toad'; and the Basilisks (q.v.). See LIZARD; and Boulenger, *Brit. Mus. Cat. of Lizards* (2d ed. Lond. 1885 '87).

Iguanodon (Iguana, and Gr. *odon*, 'tooth'), a genus of remarkable gigantic dinosaurian reptiles, more abundant in the Wealden beds of Kent, Sussex, and the Isle of Wight than any other genus of associated saurians. Their singular structure, differing in many important particulars from any known reptile, long caused great diversity of opinion as to their true position. Dr Mantell, their original discoverer and learned expounder (1822),

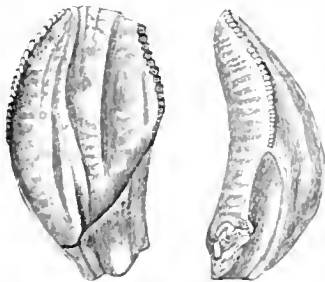

Fig. 1. Front and side view of a Tooth of the lower jaw of the Iguanodon, about two thirds natural size.

first knew of their existence from some enormous bones, which, notwithstanding their colossal size, he considered reptilian. A large tooth next turned up, whose smooth-worn crown attested its having belonged to a herbivorous animal. Numerous other specimens of teeth were in process of time discovered, and Dr Mantell found that they corresponded in a remarkable manner with the teeth of the small American lizard, the iguana, although they exhibited very striking and important differences. The first guesses as to the creature's size,

founded on fragmentary materials, varied vastly; Mantell suggesting a length of 70 feet, Owen of 28. An extraordinary recent find of iguanodonts has simplified this and other questions as to the structure. In 1878 there were found at Bernissart, in Belgium, between Mons and Tournai, the remains of about twenty three specimens, belonging to two well-marked species; only two other species having till then been proposed. In the complete skeleton set up at Brussels from these materials the height is 14 feet 2 inches; the horizontal length of the body in a half standing attitude, 23 feet.

The structure of the skeleton is very remarkable. The front parts of both upper and lower jaws were without teeth, and suggest a hollow, beak-like arrangement; possibly the creature had a long prehensile tongue. In many respects there are striking resemblances between the structure of the ornithoid Dinosaurians (of which the Iguanodontidae are a family) and that of birds. The vertebral column had joints slightly concave on both surfaces, yet had lofty neural arches; and the sacrum was composed of five anchylosed joints, a structure found in no other reptile. The two fore-legs were small; the hinder limbs were long and strong, raising the body some distance from the ground. The leg terminated in a three-toed foot, which produced the enormous tridactyle impressions on the argillaceous Wealden beds that were for some time considered to be the footprints of huge birds. The teeth of the iguanodon, while bearing

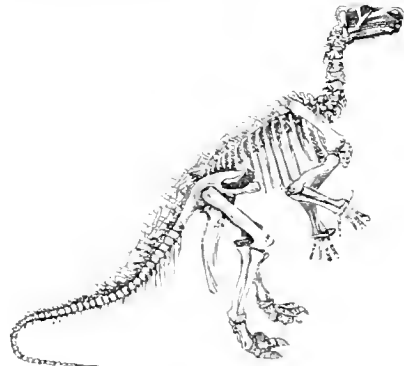

Fig. 2. Skeleton of Iguanodon.

a general resemblance to those of the iguana, were much more complicated both in external form and internal structure than in any other known reptile. In all other known reptiles the vertically flat teeth are always sharp-edged, and fitted only to cut off the plants on which they feed; but the worn crowns in this animal show that the iguanodon thoroughly triturated its food before swallowing it.

Igavium. See GUEBIO.

Thre, JOHAN, an eminent Swedish scholar of Scottish extraction, was born at Lund in 1707, and educated at the university of Upsala, where he acquired a great reputation and carried off the highest honours. He subsequently travelled in France and England, was appointed on his return to Sweden under-librarian to the Academy of Sciences, and rose through a variety of offices to be professor of Belles-lettres and Political Economy (1748). He died in 1780. Thre's principal work is his *Glossarium Sæculi Gothici* (2 vols. folio, 1769), a work of great talent and erudition, which, though a product of the pre-scientific age, may in some respects be regarded as the foundation of Swedish philology. It was issued at the cost of the state,

which gave him 10,000 dollars to execute it. Another work of lasting value is the *Scenskt Dialect-Lexicon* (1766).

Ilchester, a decayed village of Somersetshire, on the Yeo, 5 miles N.W. of Yeovil. Supposed to be the *Ischalis* of Ptolemy, it was the principal station of the Romans in this region, and was a flourishing town in Saxon times. Numerous Roman remains have been found here. Ilchester is the birthplace of Roger Bacon. Till 1832 it returned two members. Pop. 683.

Île-de-France, one of the old provinces of France, having Paris as its capital, and now mostly comprised in the departments of Seine, Seine-et-Oise, Aisne, Seine-et-Marne, Somme, and Oise. In the middle of the 9th century it was made a dukedom, and became one of the four constituent fiefs of the French monarchy. The second duke, Odo, commonly called Count of Paris, was crowned king of France in 888. His successors contended for some years for the throne of France; one of them, Hugh Capet, founded in 987 the Capetian dynasty (see FRANCE). Île-de-France was formerly the name of Mauritius (q.v.).

Ilitzk, a town in the Russian government of Orenburg, near the confluence of the Ilek with the Ural. Pop. 5769. Close by is the richest salt-bed in Russia, yielding close upon 21,700 tons of salt annually. It was discovered by Pallas in 1769, and visited by Murchison in 1850.

Ilm. See DIGESTION.

Ilms, or ILMAC PASSION. See COLIC.

Ilex, a tree often named in the Latin classics, the Evergreen Oak or Holm Oak (*Quercus Ilex*). See OAK. It is a native of most parts of the south of Europe and of the north of Africa, often attaining large dimensions, as it sometimes does where planted in Britain. It grows in general singly or in small groups, and loves the vicinity of the sea. Its leaves are ovate-oblong, acute, leathery, hoary beneath; but they vary much in some respects, from the size of a sloe-leaf to that of a beech, and from being very spiny at the edge to perfect evenness. The bark is very astringent, and is employed for tanning hides in the countries to which the tree is indigenous. Its wood is very hard and heavy, tough, durable, and useful, particularly for axles, pulleys, screws, and whatever is to be subjected to much friction. The acorns are of various quality, sometimes bitter, and sometimes sweet and eatable. In modern botany *Ilex* is the generic name of the Holly (q.v.).

Ilfracombe, a watering-place of England, is finely situated on the picturesque rocky coast of North Devon, on a cove or inlet of the Bristol Channel, 11 miles NNW. of Barnstaple (15 by a branch-line). Its air 'combines the soft warmth of South Devon with the bracing freshness of the Welsh mountains' (Charles Kingsley). This and its fine coast scenery and its admirable sea-bathing annually attract large numbers of visitors. On the north side of the (good) harbour there is a light-house, the light, 127 feet above high water, being visible for 10 miles. Although having now nothing more than a little coasting trade and fishing, Ilfracombe was in the 14th century a port of some consequence, and contributed six vessels to the English fleet for the siege of Calais. A destructive fire occurred in July 1896. Pop. (1851) 2919; (1881) 6255; (1891) 7692.

Ilhavo, a Portuguese town 40 miles S. of Oporto. Two miles distant is the glass and porcelain factory of Vista Alegre. Pop. 7800.

Ilk. See KILN.

Illicin, the bitter principle derived from Holly (q.v.).

Ilissus. See ATHENS, and METEVA.

Ilium. See TROY; and for Iliad, see HOMER.

Ilk (O.E. *gþ*, 'the same'), an old form found both in English and Scotch meaning the same. Thus, Chaucer has 'this ilk worthy knight' and 'that ilk man.' It is still not unknown in Scotland in connection with family designations; thus, 'Kinloch of that ilk' means 'Kinloch of the estate of that same name, or 'Kinloch of Kinloch.' Of that ilk' is however constantly but absurdly and ignorantly used to mean 'of that description,' as in 'carpetbaggers and politicians of that ilk.'

Ilkeston, a market town of Derbyshire, near the Erewash River, 9 miles ENE. of Derby, and 20 S. of Chesterfield. It enjoys repute from its alkaline spring and baths (opened in 1830). The parish church, with a lofty pinnacled tower, has interesting Norman and Early English features. The town-hall was built in 1868. Ilkeston has manufactures of hosiery, lace, silk, and earthenware, with coal and iron mines in the vicinity. In 1251 a charter for holding a market and fair here was granted to Hugh Fitz-Ralph; and in 1887 Ilkeston was incorporated as a municipal borough. Pop. (1861) 3330; (1881) 11,122; (1891) 19,744.

Ilkley, a watering-place in the West Riding of Yorkshire, on the Wharfe, among heathery hills, 13 miles NNW. of Bradford and 16 NW. of Leeds by a branch-line (1865). Since 1846 it has become the seat of several hydropathic establishments—Ilkley Wells House, Ben-Rhydding (q.v.), &c. It occupies the site of a Roman station, and in the churchyard are three curious Saxon crosses; whilst Bolton Abbey (q.v.) is 5 miles north-west. Pop. (1851) 811; (1891) 5767.

Ill, a river of Alsace, rising to the south-west of Basel, and flowing 127 miles north-eastward, till it falls into the Rhine 9 miles below Strasburg. It is navigable over nearly one-half of its course.

Ille-et-Vilaine, a maritime French department, formed out of the north-eastern portion of the old province of Brittany. Area, 2396 sq. m.; pop. (1872) 589,532; (1891) 626,875, mostly of Celtic race. It is watered chiefly by the Vilaine and its tributary the Ille, which unite near Rennes, the capital of the department. Ille-et-Vilaine consists of a granite plateau traversed by ranges of low hills. It is agricultural, cultivation having been greatly improved during recent years. The cider of this district is the best in France; the butter of Rennes is celebrated; the horses of the department are noted for their endurance, and are in great request for the army; and bee-keeping is prosecuted. Iron is mined; slates are quarried; and salt is extracted. The department is divided into six arrondissements—Rennes, Fougères, Montfort, St Malo, Vitre, and Redon. St Malo is the principal seaport.

Illegitimacy, by the laws of England, debars a child from the inheritance of the father, unless express provision be made by will (see BASTARD). It was even held by Mr Justice Chitty (Chancery Division, July 1889) that the term 'children' in a will does not comprise illegitimate issue, if the wording otherwise is not such as obviously meaning to include them.

The whole subject of illegitimacy forms one of the most difficult of the social problems; and there is no branch of social science in which there is such deficiency of literature. And yet its importance is sufficiently evidenced by the fact that 40,730 illegitimate children were born in England and Wales, and 10,880 in Scotland, in one year. In 1888 the illegitimate births registered in England amounted to 4.6 per cent. of the total births, and to 1.4 per 1000 living persons. The birth rate of that year was the lowest in England since the present

system of registration began; but it is noticeable that, while the marriage rate, and consequently the legitimate birth rate, has declined steadily for some years, the illegitimate birth-rate has also steadily declined. From 1841 to 1859 the proportion of illegitimate births to the total number registered ranged from 6.3 to 7 per cent.; in the ten years from 1878 to 1887 the average was 4.8 per cent.; in 1888 the proportion was 4.6 per cent. The decline is very striking, because, in the period first mentioned, the rate fluctuated between 6 and 7 per cent. with a remarkable uniformity. In the year 1845, 70 out of every 1000 births registered in England and Wales were illegitimate; in 1888 only 46 out of every 1000. Illegitimacy was greatest in the following districts, the figures here given being the illegitimate births in every 1000 births registered: Norfolk, 74; Herefordshire, 85; Shropshire, 80; Cumberland, 78; and North Wales, 73. Middlesex (extra-metropolitan) compares favourably, with 34; Yorkshire shows for West Riding 49, East Riding, 56, and North Riding, 62; and the great industrial counties come out with Durham, 40; Northumberland, 49; Lancashire, 44; Derbyshire, 43; Warwickshire, 42. The marriage rate is proportionately low. Thus, while the average marriage-rate in England and Wales in 1888 was 14.2 per 1000 persons, the marriage-rate of Hereford was 11.5; Shropshire, 11.4; Norfolk, 13.4; Cumberland, 12.6; and North Wales, 11.6. In comparing with the returns of past years we find many fluctuations in the counties; but, generally speaking, the highest rates of illegitimacy in the least densely populated districts. Unfortunately we cannot derive from this fact any conclusion referring to the education or prudential habits of the people, for in Scotland, where education is general, and thrift national, the rate of illegitimacy is notoriously high. And, as regards morals, it should be remembered that a high percentage of illegitimacy may mean that there is no prostitution.

In the year 1887 there were 10,380 illegitimates registered in Scotland out of a total of 124,418 births, but in 1866 there were 11,673 out of 113,667. This marks a considerable improvement, and in fact during the twenty years 1879-88 there was a steady, although not a continuous decline in the rate. The rate for 1888—8.34 per cent.—was slightly higher than that of the previous year; that of 1889 was only 7.85. The following detailed figures are based on the returns for 1888. In the principal towns the rate was as follows: Glasgow, 8.3; Edinburgh, 8.5; Dundee, 10.3; Aberdeen, 10.3; Greenock, 5.3; Leith, 6.6; and Paisley, 6.3 illegitimates out of every 100 registered. The lowest proportion in urban Scotland was in Glasgow—landward and suburban district, 4.3. The highest rural proportion was in Wigtownshire, with 18.2; and the lowest rural proportion was in Kinrossshire, with 4. Next to Wigtownshire for illegitimacy came Banffshire, with 16.8; Kirkeudbright, with 15.7; Elginshire, with 15.2; Dumfriesshire, with 13.9; Aberdeenshire, with 13.2; Kincardineshire, with 12.4; Roxburghshire, with 11.2; and Berwickshire, with 11.1 per cent. The average is brought down by the low rates in the shires of Kinross, Ross and Cromarty, Dumbarton, Renfrew, Fife, Clackmannan, Stirling, Bute, Lanark, and Linlithgow, which range between 4 and 6.8 per cent. The other counties range about the average for all Scotland, with the exception of Shetland, which shows the comparatively low rate of only 4.8 illegitimates in every 100 births. In 1889 Shetland was the lowest country, with 4; Kinross having 6.7; Wigtown had 17.7 per cent. What is called the insular rural districts had an average of 6.2. The comparison

for 1888 may be otherwise summed up thus: 1 child in every 12 born throughout Scotland was illegitimate; but in the principal towns the proportion was 1 in 13; in the large towns, 1 in 15; in the small towns, 1 in 12; in the mainland rural districts, 1 in 10; and in the insular rural districts, 1 in 16. The tendency to illegitimacy in Scotland is greater in the north-eastern and southern rural districts than in the south-western mining and manufacturing districts—which is much the same distinction as we observed in England. Only, in no part of England are the figures so deplorable as in Scotland. Various theories have been advanced to account for this, but it is doubtful if the whole solution has yet been found. The following may at any rate be instanced as among the probable causes of the prevalence of illegitimacy in Scotland: a national caution, which deters from early and improvident marriages; the laxity of the marriage-laws in respect of the subsequent legitimation of children born out of wedlock; and the herding together of farm-labourers in bothies and farm-buildings. It is to be noted, also, that a large proportion of the illegitimacy can hardly be ascribed to vice, seeing that the parents often live together and rear their families just as if they were legally married, and as, perhaps, many of them will be some day. For this curious practice no doubt the former high proclamation fees may have been to some extent responsible.

In Ireland we find a very different state of affairs. There, in 1888, of 106,433 births registered only 3124 or 2.9 per cent. were illegitimate. Since 1884 the percentage has ranged between 2.7 and 2.9. This is the average for the whole island, but in Ulster the percentage was 4.4; in Leinster, 2.5; in Munster, 2.2; and in Connaught as low as 0.7. Dublin county was chargeable with nearly one-tenth, Londonderry county with about another tenth, and Antim with about one-fifth of the whole. The marriage-rate in Ireland is curiously low, being only 4.20 per 1000 of the population, as against 14.1 in England, and 12.4 in Scotland. Poverty may explain the low marriage-rate, and it is noticeable that of the 78,684 emigrants of that year over 80 per cent. were between fifteen and thirty-five years old—that is, of the marriageable age. The infrequency of bastardy can, however, only be ascribed to the chastity of the people, early marriage, and the wholesome restraints of the church.

To turn now to British colonies, we shall find some interesting figures; but it is important to bear in mind that birth-rates, like marriage rates, based upon a comparison with the total population, are somewhat misleading where the population is in an abnormal condition. As in most of the colonies the males largely exceed the females, there must necessarily be an abnormally small proportion of child-bearing women. In 1887 the illegitimate births in Victoria numbered 1580, or 1 in every 21 births registered. This rate shows a small increase since 1880, when the rate was 1 in 27. The mean for fifteen years was 4.25 per cent. of the total births, but the total for 1887 was 4.78 per cent. of the births. As regards the other Australasian colonies, illegitimacy is most rare in New South Wales, where it was (1886) 1.65; next in Queensland (1886), 3.97; next in Tasmania (1887), 3.40; and next in New Zealand (1886), 3.12 to every 100 children born. These figures are remarkably low, but then we must remember that the populations are not yet in a normal condition, and also that the statistics of illegitimacy for many reasons never reveal the whole truth.

This fact must be borne in mind in considering the following table of the proportion of illegitimacy in all the countries of the world for which

figures are available. The figures given are all for the period 1881-90.

	Year	Per cent of illegitimates to total births
England and Wales	1888	4.6
Scotland	1887	8.34
Ireland	1888	2.9
Austria (average)	1887	14.80
Carinthia		15.00
Lower Austria and Styria		25.00
Upper Austria		20.00
Dalmatia		3.50
Hungary		8.00
Belgium	1887	9.30
Denmark	1886	10.00
France	1887	8.20
Germany (average)	1886	9.47
Upper Bavaria		15.67
Schaumburg Lippe		2.74
Prussia		8.24
Alsace Lorraine		8.10
Greece	1889	1.60
Holland	1887	3.22
Italy	1887	7.45
Portugal (certain provinces only, returns incomplete)	1885	11.00
Roumania	1887	5.00
Russia (average 1867-81)		3.00
Spain	1884	5.40
Sweden	1886	14.88
Norway	1886	7.90
Switzerland	1887	4.80
Brazil (estimate)	1884	25.00
Canada		
Costa Rica	1886	24.00
Guatemala—Whites	1887	50.00
Indians	"	25.00
United States		
New South Wales	1886	1.65
Victoria	1887	4.78
Queensland	1886	3.97
South Australia, no statistics		
West Australia	1888	3.95
Tasmania	1887	3.40
New Zealand	1886	3.12

In the following table we show the comparative prevalence of illegitimacy in the principal foreign cities:

ILLEGITIMATE BIRTHS TO EVERY 1000 BORN.

Vienna	449	Leipzig	211	Ghent	144
Prague	429	Dresden	208	Hamburg	138
Munich	429	Milan	204	Frankfort	132
Stockholm	396	Rome	194	Turin	132
Moscow	390	Venice	181	Antwerp	129
Budapest	299	Breslau	186	Cologne	124
Copenhagen	279	Bucharest	175	Palermo	101
Paris	268	Liege	174	The Hague	99
St Petersburg	236	Christiana	162	Naples	86
Frieste	211	Berlin	154	Rotterdam	70

None of the above figures are presented as absolutely accurate. They can only be approximate in the best case, for in every country there must always be a large number of bastards who either are not registered at all, or who are registered as legitimate. But as far as they go the figures are instructive. They do not, however, enable one to form any conclusion as to the causes of illegitimacy in respect either of religion, of education, of industrial occupation, or of distribution of population. Neither can any theory be well evolved from a racial basis when we find Sweden with as high an average as Austria, and both with more than twice the average of Italy and Spain. It is a remarkable fact that in the year 1851 more than one half of the entire births in Vienna were

In the cases marked with an asterisk the percentage is of *avuncular* births; in the other cases, of total births registered, including still-born.

† No statistics are available for Canada.

‡ In the United States there seems no efficient system of registration of marriages and births, a fact upon which the Commissioner of Labour comments in his recent special report on "Marriage and Divorce" in the republic. Some of the individual states record the illegitimate births, but the figures are unshading because incomplete. Thus, the state of Indiana returned, in 1886, 38,370 legitimate and 500 illegitimate births, the illegitimate being only about 1.06 of the whole, a result which in the light of the above table we can only regard as due to defective registration.

illegitimate, but there is no explanation forthcoming of that fact, nor of the improvement revealed in the above table. In Europe generally, although not universally, there seems a tendency to decrease in the rate of illegitimacy; but how far that appearance may be due to moral causes or merely to more comprehensive statistics it is impossible to say.

In the periodical reports of the respective registrars-general will be found details referring to England, Scotland, and Ireland. The *Victorian Year-book*, by H. H. Hayter, government statistician, may be consulted for the Australasian colonies. The figures for foreign countries have been compiled from official and other sources too numerous to mention. Information about illegitimacy is given in the *Journal de la Société de Statistique de Paris* (24th and 26th years); in *Procedimientos del Departamento Nacional de Estadística, 1886* (Buenos Ayres, 1887); and in *Popolazione. Movimento dello Stato Civile e Condizioni Interazionali per gli anni 1865-83* (Rome, 1884). In the Journal of the Royal Statistical Society (London) for 1859 and 1862 there are interesting papers on the subject. See also A. Leffingwell's *Illegitimacy and the Influence of the Seasons on Conduct* (1892).

Illimani, one of the principal mountains of the Bolivian Andes, 10 miles SE. of La Paz. Height, 21,150 feet. See ANDES.

Illinois, the seventeenth in area of the United States, but the third in population, extends from Wisconsin and Lake Michigan on the N. and NE. to the junction of the Ohio and Mississippi rivers at the extreme SW. a distance of nearly 400 miles. It is bounded on the E. by the state of Indiana, from which it is partly separated by the Wabash River; on the S. it is separated from Kentucky by the Ohio; and on the W. the Mississippi flows between it and the states of Iowa and Missouri. The area is 56,650 sq. m., or nearly that of England and Wales.

The surface of Illinois is the most level of any state in the Union, except Delaware and Louisiana; and its wide grassy plains, though broken by numerous streams fringed with belts of fine timber, have gained for it the name of the Prairie State. The drainage is towards the south-west, through streams which flow into the Mississippi. The Illinois River, the largest in the state to which it gives name, is formed by the union of two streams in the north-east of the state, about 45 miles south-west of Lake Michigan, and has a south west course of about 500 miles in all, joining the Mississippi 20 miles above the mouth of the Missouri. The fertile soil—a heavy black loam with a favourable climate, makes this the richest agricultural state in the Union; and Illinois ranks first for the production of corn, cattle, hogs, and horses.

The annual value of the principal crops—maize, oats, hay, wheat, potatoes, rye, barley, buckwheat, flax, tobacco—is well over \$150,000,000. There are extensive vineyards in the state, and good wine is made. Much fruit is raised, especially for the markets of Chicago. Forests still cover a large area of the land. Honey and wax are obtained on a large scale. There are 1,500,000 horses and mules, over 3,000,000 cattle, and 1,000,000 sheep in the state.

The mineral output of Illinois, especially of bituminous coal, is also large; the state ranks next to Pennsylvania in this respect. Nearly a fifth of the entire coalfield of the United States is found in this state; and though some three-fourths of the coal is found in the Joliet region in the north-east, there are some 900 collieries in about fifty separate counties of the state. The annual output reaches 15,000,000 tons, and the industry employs 30,000 persons. There are brine-springs in the south of the state. Iron and zinc are also worked; and other

minerals are lead, limestone, salt, and fluor spar, the last found near Roseclare.

The position of Illinois presents unusual facilities for commerce. It has 400 miles of navigable rivers; a waterway to the Atlantic through the great lakes; and the drainage canal (1900) from the Chicago River to the Desplaines connects Chicago with the Mississippi River. Illinois has more railroads than any other state—10,776 miles in 1897. The trade of the state centres in Chicago, and in the article on that city statistics are given, as well as some indication of the leading manufactures. Of these last the principal are connected with agriculture.

The state is divided into 102 counties. The governor and most of the other state officers are elected for four years, the judges of the supreme court for nine. The legislature meets biennially; and to the lower house each district returns three members, cumulative voting being permitted in order to provide for the representation of minorities. Twenty representatives are sent to the Federal congress. The provisions for education are liberal. The state maintains two normal schools, an agricultural college, and an industrial university; and besides these there are many other colleges and universities. A compulsory educational law is in force, which requires children between the ages of seven and fourteen to attend for at least sixteen weeks in the year some public day school, or some private school teaching the branches commonly taught in the public schools. The most important educational institutions, including the magnificently endowed Chicago University, are in and about Chicago (q.v.). Thirty higher institutions have 700 teachers and over 10,000 pupils. Over 25,000 elementary teachers instruct 800,000 pupils. The state charitable institutions include four hospitals for the insane, at Elgin, Kankakee, Jacksonville, and Anna; an institution for the deaf and dumb, and another for the blind at Jacksonville; an asylum for the feeble-minded at Lincoln; a home for the orphans of soldiers at Normal; and eye and ear infirmary at Chicago; a reform school for boys at Pontiac; and a soldiers' and sailors' home at Quincy. The 475,000 Roman Catholics in the state have an archbishop and three bishops.

Formerly a part of the North-west Territory, Illinois was organised as a territory in 1809, and admitted as a state on 31 December 1818. While the Federal law at that date made a population of 40,000 a condition of admission, it is well established that the actual population of Illinois was then but 34,629. In 1830 the population numbered 137,445; in 1850, 851,470; in 1870, 2,539,891; in 1880, 3,077,871; and in 1890, 3,826,351. Chicago is by far the largest city of Illinois; its limits embrace more than a fourth of the entire population of the state. Peoria, Quincy, Springfield (the capital), and Rockford rank next in population. Important events in the history of Illinois have been the Indian wars of the territorial period, the Black Hawk war of 1832, and the Mormon (q.v.) troubles in 1840-44. The state raised six regiments for the Mexican war, and during the civil war contributed 259,092 men to the Union armies, of whom over 29,000 were killed in action or died of wounds or disease. At Springfield Abraham Lincoln lived before he was elected president, and there he is buried. See S. Breese, *Early History of Illinois* (Chicago, 1884); J. Moses, *Illinois, Historical and Statistical* (Chicago, 1889).

Illiterates, a term used to designate those persons who are unable to read or write, or both. The percentage of illiterates in a country furnishes one of the few means of estimating quantitatively the average level of intelligence, or at least of education, possessed by the people of that country.

Unfortunately a strict comparison cannot be made, because the statistics of illiteracy in different countries are not based upon one uniformly recognised method of obtaining them. (1) A few countries—e.g. the United States, Hungary, Italy, and Portugal, and the Australian colonies of Victoria and Tasmania—have endeavoured to take an exact census of illiterates; in their enumerations all children below six years of age were excluded, except in the United States, which excluded all children below ten years of age.

United States (1880) 22·15 per cent. Hungary (1880) 37·14 per cent.
Italy (1881) 54·30 " Portugal (1878) 79·07 "

The high percentage of the United States is due to the low educational status of the Negro population. In 1881 there were in the colony of Victoria 23·80 per cent. of illiterates, and in Tasmania 43·78 per cent. Of the other methods that are employed to ascertain the number of illiterates (2) the most complete results are afforded by the enumeration of the men and women who, on the occasion of their marriage, are unable to sign their names in the registers. On this basis we have the following results for comparison in the year 1886

Country.	Men.	Women.	Per cent.
England and Wales.	9·60	11·50	10·55
Scotland.	4·65	8·28	6·46
Ireland.	23·40	25·50	24·45
Victoria.	2·00	1·98	1·99
New South Wales.	3·76	4·20	3·98
Queensland.	4·52	6·71	5·62
South Australia.	3·04	3·49	3·26
New Zealand.	1·92	2·89	2·40
Prussia (1884)	5·31	5·11	4·21
France (1882)	14·59	22·62	18·50
Italy (1887)	42·36	62·80	52·58

It may be stated that while in England and Wales, in 1863, 23·8 per cent. men and 33·1 per cent. women signed their marriage register by mark, in 1897 the figures were only 3·3 per cent. men and 4·9 per cent. women. In Scotland in 1897 the proportion was 2·16 per cent. men and 3·27 per cent. women, while in several counties all signed their names. In Ireland, in the same year, the proportions were 15·1 per cent. men and 13·2 per cent. women. (3) The subjoined table gives the number of recruits who were unable to read and write in the respective countries named, and where universal conscription is in force:

Belgium (1884)	0·02	Holland (1887)	8·5
Württemberg (1884)	0·02	France (1886)	10·50
Bavaria (1884)	0·08	Belgium (1887)	13·87
Saxony (1884)	0·15	Austria (1885)	25·09
Sweden (1883)	0·27	Hungary (1885)	38·60
Denmark (1884)	0·36	Italy (1885)	129·8
Germany (1884)	1·27	Russia (1882)	78·79
Switzerland (1885)	1·3	Serbia (1884)	75·61
Prussia (1884)	1·97		

(4) At the general election of 1886 in Great Britain and Ireland there voted in England and Wales 38,587 illiterate persons, in Scotland 4836, in Ireland 36,722, giving a percentage of 2·60 out of a total of 2,969,381 voters who went to the poll. (5) Out of a total of 31,473 persons of all ages arrested in the colony of Victoria, in the year 1887, 26,509 could only read or write imperfectly, and 3333 were totally unable to read, a percentage of 86·56 illiterates apprehended. Illiteracy among voters, both white and black, increased enormously in the south of the United States between 1870 and 1880. In Texas in 1870 there were 17,500 illiterate voters; in 1880 there were 33,085. But between 1880 and 1890 the illiteracy in the States was reduced to 13·1 per cent. of the total population. People unable to sign their name attest a document by making a cross, certified by a witness who can write.

Illorin. See ILORI.

Illuminati (Lat. 'the enlightened'), a name assumed by or conferred upon various mystics professing to have special knowledge of God and things

divine. The sects which may be included under the title are the *Alumbrados*, who originated in Spain about 1520, and were finally crushed by the Inquisition; the *Guarriors* in France, who flourished from 1623 to 1635; another sect which arose in the south of France about 1722, and perished in the storms of the Revolution; an association of mystics in Belgium, in the later half of the 18th century. But the name is more particularly given to the Order of the Illuminati, founded at Ingolstadt on May 1, 1776, which soon spread over almost all the Catholic parts of Germany. Its founder, Adam Weishaupt (1748-1830), professor of Canon Law at Ingolstadt, at first called it the Order of the Perfectibilists. Filled with detestation of Jesuitism, and impatient of the restraints which were at that time imposed on the freedom of human thought in Catholic Germany, especially in Bavaria, Weishaupt set himself to combat ignorance, superstition, and tyranny, by founding an association which should be a luminous centre for the promotion of rational and religious enlightenment. Religious dogmas and forms of worship were rejected; his religious system was a form of deism. But the society prosecuted political aims as well, in that the members of the highest of the orders into which it was divided were pledged to the furtherance of Republican opinions. Implicit obedience to the chiefs of the association was one of the first laws of its constitution. The accession of Baron von Knigge to the new order, and the support which it received from the Freemasons, led to its rapid extension; about 1780 it counted more than 2000 adherents, mostly men of rank and influence. It was regarded with favour by Goethe, Herder, Nicolai, Ernest H. of Gotha, and Karl August of Weimar. Weishaupt and Knigge quarrelled in 1784. The order began to be openly denounced as dangerous, in 1784 and 1785 edicts were issued by the Elector of Bavaria for its suppression, and Weishaupt was degraded and banished. See his *Geschichte der Verfolgung der Illuminaten* (1787) and *Kurze Rechtfertigung meiner Absichten* (1787).—*Illuminism*, the system of the French illuminati, is sometimes used as a synonym for Freemasonry and unbelief, from a Catholic point of view.

Illumination of Manuscripts, the art of painting manuscripts with miniatures and ornaments, an art of the most remote antiquity. The Egyptian papyri containing portions of the Ritual or 'Book of the Dead' are ornamented with veritable drawings and coloured pictures. Except these papyri, no other manuscripts of antiquity were, strictly speaking, illuminated; such Greek and Roman manuscripts of the 1st century as have reached the present day being written only. Pliny, indeed, mentions from Varro that authors had their portraits painted on their works, and refers to a biographical work, with numerous portraits introduced, but all such have disappeared in the wreck of ages; the oldest illuminated MSS. which have survived being the *Dioscorides* of Vienna and the *Psalm* of the Vatican, both of the 4th century, and ornamented with vignettes or pictures in the Byzantine style of art. St Jerome, indeed, in the same century, complains of the abuse of the practice, as shown by filling up books with capital letters of preposterous size. The Byzantine style strongly influenced every other early style throughout the West, and its influence can be traced as late as the 14th century.

The art of illuminating manuscripts with gold and silver letters is supposed to have been derived from Egypt, but it is remarkable that no papyrus has any gold or silver introduced into it. The artists who painted in gold, called *Chrysographi*,

are mentioned as early as the 2d century. One of the oldest manuscripts of this style is the *Codex Argenteus* of Uffilas (360 A.D.); and the charter of foundation of Newminster at Winchester by King Edgar (966 A.D.), six centuries later, shows the use of these letters. Gold letters seem to have been used in the East during the 12th and 13th centuries. At an early period the use of illuminated or decorated initial letters commenced to be distinguished from the illuminated or painted pages placed at the head of Byzantine manuscripts. Originally they were not larger than the text, or more coloured; but the Syriac manuscripts of the 7th century have them with a pattern or border; and they go on increasing in size and splendour from the 8th to the 11th century, when large initial letters, sometimes decorated with little pictures or miniatures, came into fashion in the Greek and Latin manuscripts. The subjects of the figures mixed up with the arabesque ornaments often referred to the texts; warriors and warlike groups of figures being introduced when the text referred to war, symbolical representations of hell where the chapters following treated on that region. These initial letters soon increased to a great size, being from 2 to 24 inches long; they were most used in the 8th and 9th centuries, but continued till the 12th century, and degenerated in the 16th to the last decadence of art—the grotesque. In the 13th century burnished gold was used as a background for letters and miniatures, and so finely were these backgrounds executed that they appear like plates of solid gold. The art which flourished in the eastern and western empires passed over to Ireland, and there gave rise to a separate school or kind of illumination. This style, which consists in a regular series of interlaced ribbon ornaments, often terminating in the heads of gryphons and other animals, seems to have been derived from the later patterns of Byzantine art, seen on mosaics, mural paintings, and other objects. This Celtic style is finely exhibited in the remarkable MS. at Trinity College, Dublin, known as the 'Book of Kells,' which is believed to be of the 9th century. The minute size and number of the interlacements is quite wonderful.

The Hiberno-Saxon style is seen in the so-called Durham Book in the British Museum (Cott. MS. Nero D. IV.), which is only second to the Book of Kells in beauty. It was written by Eadfrith, Bishop of Lindisfarne (died 721), in honour of St Cuthbert. The various schools of art in the middle ages found their homes in the different monasteries, and the so-called *Opus Anglicanum* is exhibited in the Benedictinal now in the possession of the Duke of Devonshire at Chatsworth. This was produced at the Old Minster at Winchester, and was executed by Godemann (afterwards abbot of Thorney) for Ethelwold, Bishop of Winchester (963-984).

In the 12th century a new style arose which was distinguished by the profusion of its ornamentation, intricate modes of illumination, and abundant use of gold and silver. In the 13th century the art still more deteriorated in western Europe, but the manuscripts of the 14th century show a great advance in painting over the works of previous centuries. Dante's *Divina Commedia* in the British Museum (Egerton MS. 963) is a fine specimen of the work of Italian artists in this century. The Arundel Psalter, also in the British Museum (Arundel MS. 83), is a noble work of English artists. It was given by Robert de Lyle to his daughter Andry in 1339.

In the 15th century the art of miniature began to decline in England, and the finest works were produced by foreign painters. This is the case

with the famous Bedford Missal in the British Museum. It was prepared for John, Duke of Bedford, son of Henry IV. and Regent of France, on his marriage in 1423 with the daughter of John, Duke of Burgundy. The duchess presented the MS. (with her husband's consent) to Henry VI. on Christmas Eve, 1430. In this same century were produced the celebrated choir books in the cathedral of Siena, by Girolamo da Cremona and Liberale da Verona, who were paid for their work in 1468 and 1472-73. One of the most beautiful specimens of the work of the next century is the Book of Hours of Anne of Brittany, wife of Louis XII., which has borders of natural plants on a gold ground. The artist to whom we are indebted for this priceless monument of French art at the period of the Renaissance was Jean Bourdichon (1457-1521).

The usual mode of production adopted in the Scriptorium was for the scribe to rule a space for his text in accordance with the general design, and to write within these limits. He was followed by the illuminator of initials, borders, and ornamental accessories. Then came the miniaturist. St David, the patron saint of Wales, is said to have been an assiduous illuminator, and among the most celebrated miniaturists may be mentioned Giotto (1276-1337), Fra Angelico (1389-1455), Attavante (1455-1520), Julio Clovio (1498-1578), Vincenzo Raimondo (died 1557), and Boccardino (16th century). Raphael and Jan van Eyck might be added to the list. That splendid example of Flemish illumination, the Franciscan Breviary of Cardinal Domenico Grimani (1461-1523), has been attributed to Memling, but later inquiries have proved that he had nothing to do with it.

In the reign of Louis XIV. the art became extinct, ending with a style of painting called *encreux gris*, a kind of monochrome, in which the lights are white or gold, and shaded so as to emulate bas-reliefs. Among oriental nations the Persians, Hindus, and Chinese have illuminated manuscripts of great beauty, none of which, however, can compete with those of the western nations in antiquity. For beauty of design some of the Arab manuscripts are charming, but their antiquity does not reach beyond the 13th century. The Chinese Buddhists have also illuminated classics, or religious books of their sect, one of which, the *Diamond Book*, as it is called, in the British Museum, has a text splendidly printed in silver and gold letters on a blue ground, and the vignettes charmingly painted in tempera, on macerated leaves of the *Ficus Indica*.

See J. W. Bradley, *Manual of Illumination* (1861); *Dictionary of Miniaturists* (3 vols. 1887-89); H. Shaw, *The Art of Illumination* (1866); W. & G. Audsley, *Guide to Illuminating and Missal Painting* (1861); De Gray Birch & Jenner, *Early Decorative and Illuminations* (1879); J. H. Middleton, *Illuminated Manuscripts* (1892); Falconer Madan, *Books in Manuscript* (1893).

Illuminations. See PYROTECHNY.

Illusions are usually distinguished, as having some basis in outward physical facts, from *delusions*, which are purely subjective hallucinations, with no foundation save perverted imagination, or otherwise disordered faculties. Optical illusions are exemplified by the appearances connected with mirage. See OPTICAL ILLUSIONS, APPARITIONS, DREAMS, HALLUCINATIONS, INSANITY; and Sully's *Illusions* (Inter. Sc. Series, 1881).

Illustration of Books. Since man first discovered how to convey his thoughts to others by means of writing, he seems to have felt the want of some method of illustration or embellishment. From the Egyptian papyrus down to the invention of printing this was supplied by pictures,

coloured or uncoloured, engravings, carvings, &c., executed by hand, and so far as these have any connection with books or writings their history will be found in the article ILLUSTRATION OF MANUSCRIPTS. The first printed books were entirely illustrations, both pictures and text being printed from blocks engraved on wood in relief, such as the *Biblia Pauperum* (q.v.), and many others. The *Ars Memorandi* (end of 15th century) comprised fifteen New Testament pictures, faced by the same number of text pages, all engraved on wood. The Mazarin Bible (1455), the first book completely printed from movable types, many of the copies of which were beautifully embellished by hand, was sold as a manuscript, till the number of copies aroused suspicion. Many other spurious MSS. were produced in the same way, the larger price obtained for them forming a temptation to those having the secret of printing.

The first edition of the *Speculum Humanae Salvationis*, said to have been printed by Coster about 1440, is supposed to be the first book in which two different coloured inks were used on the same page; and the ornamental capitals in the Psalter of Pust and Schöffer in 1457 are beautiful specimens of printing in two colours. Probably the first printed book with wood-engraved illustrations used throughout the text was the *Fables of Ulrich Bolmer*, issued by Albert Pfister, printer of Bamberg, in 1461, which had 101 engravings on wood. In Italy the first known example is the *Meditationes*, published by Ulrich Halm, a German, in Rome, 1467, of which three copies are still known to exist. The most artistic book of this period was certainly a volume on military art by Valturinus, illustrated by eighty-two designs by Matteo Pasti, at Verona, in 1472. The designs are in outline and very cleverly drawn, though poorly engraved.

The invention of the method of printing from engraved (intaglio) plates introduced a new factor into book illustration. *Il Monte Santo di Dio* (Florence, 1477) was the first book issued with illustrations engraved on metal.

In the beginning of the 16th century many books were beautifully illustrated by pictures in chiaroscuro, produced by three or four blocks, engraved on wood, printing different shades of the same colour, generally ochre, brown, gray, or red, many of the original drawings being by Titian, Raphael, Parmigiano, and other masters. About the middle of the 16th century engraved plates began to be used in conjunction with wood-engravings in the same books; and from this period a struggle for supremacy began between the two arts, which finally resulted in favour of metal at the end of the century. Wood-engraving declined till revived by Bewick, and metal-engraving and etching had the field to themselves. During the 18th century many books were beautifully illustrated by engraved and etched title pages, vignettes, and tailpieces, the most celebrated artists making designs for the purpose; the type was first printed, leaving spaces on which the plates were afterwards printed. The lead taken by France in the 18th century was closely followed by Germany and England. Coloured illustrations, when not coloured by hand, as they generally were, were printed by means of numerous carefully prepared wood blocks, each printing a different colour. An elaborate account of the method will be found in Savage's work. In short, the history of book illustration reflects more or less faithfully the state of art of the period, and it may be traced in the articles, Book, Engraving, Wood engraving, Bartolozzi, Bewick, Caxton, Durer, Hogarth, Turner, &c.

The invention of lithography in 1796 introduced a third element, which was immediately taken

advantage of. Being much cheaper than steel-engraving, it gradually tended to supersede that process for book purposes, its special adaptability for coloured work giving it great advantages over its rival. In England book illustration may be said to have reached its culminating point as regards engraved and etched plates in the first half of the 19th century, in the series of annuals, keepsakes, and the higher-class books illustrated by such masters as Stothard, Turner, &c. The revival of wood-engraving by Bewick and his pupils gradually led to the restoration of that art as an illustrating medium. In this it was greatly aided by the facility with which wood engravings can be printed along with the text, together with the advance made in typographic printing. The series of Christmas books illustrated by John (afterwards Sir John) Gilbert and Birket Foster had no small share in that advancement. Among the artists who have helped to raise the art to its present high position may be mentioned Cruikshank, H. K. Browne (Phiz), Doyle, Leech, Tenniel, Millais, F. Walker, W. J. Linton, Herkomer, &c. The development of what has been called the American school of wood-engraving has still further increased the influence of that branch of art for illustrative purposes.

Relief-block Processes for Book Illustration.—While Photogravure (q.v.) threatens the final extinction of steel-engraving, very many processes have been invented to produce relief blocks with a view to supersede wood-engraving in book illustration. The object aimed at is to reproduce drawings in line or wash, in fac-simile, on a relief block capable of being printed from the surface at the type press. That is, the lines or parts which impress the paper are to be left in relief, while the white parts are cut out so as to leave the paper unprinted.

What are called 'process' relief blocks may be divided into two kinds—those reproduced from black-and-white, or line drawings by pen and ink, and those from half-tone photographs or wash drawings. The former, as being the simpler, we shall describe first.

The simplest form of it is when a drawing is made in transfer ink on lithographic transfer paper (see LITHOGRAPHY), or when a proof of a line drawing on stone or line engraving can be got in transfer ink. This transfer drawing or proof is transferred to the polished surface of a zinc plate in the ordinary lithographic manner. Zinc is generally used, because it is cheap, and is readily soluble in etching acid; but copper is sometimes used for very fine work. After the transfer the plate is wetted, and the lines are inked repeatedly till a thick coating of ink covers the lines of the drawing. Powdered asphalt, or other similar substance, is then dusted over the plate, which is gently heated till the asphalt is incorporated with the ink. The back of the plate and the other parts not requiring to be etched are covered by varnish, and the plate is put into a bath of acid for the uncovered parts to be etched away, leaving the lines in relief. As the etching, if carried on continuously, would undermine the lines and finally cut them off altogether, the plate is removed from the bath after a very slight etching. It is then washed and gently heated, which causes the asphalt and ink to run down the side of the lines already in relief, and protect them from further etching. This is a very delicate part of the process, and great skill is required to let the protecting compound run down enough and no more. The plate is returned to the bath and etched a little more. The washing and heating is repeated, and so the etching and heating goes on gradually till a sufficient depth is obtained

for the fine parts. During the etching a rocking motion is given to the bath to make the acid act more equally and allow the bubbles of gas to escape. The larger white parts are generally cut deeper afterwards with machine drills.



When other than transfers are to be reproduced, such as pen-and-ink drawings, engravings, or any other drawing in line, the subject is photographed to the required size. Here this process has a decided advantage over that just described, inasmuch as the drawing to be copied may be made of any convenient size, while a drawing on transfer paper must be of the exact size required. The photograph being obtained, it is treated as for a photolithograph (see LITHOGRAPHY), transferred to stone, and a re-transfer taken to put on the zinc, which is then treated as already described. By this process a little of the sharpness of the drawing is lost by the repeated transfers, every one tending to thicken and blur the lines a little; a more direct method of putting the drawing on the zinc is as follows. The plate is thinly and evenly coated with bitumen, bichromatised albumen, or other substance sensitive to the action of light. A very strong photographic negative, taken in reverse from the drawing, in which the lines are clear glass and the lights as dense as possible, is put on the plate and exposed to the light. The light acting through the lines on the negative render the corresponding parts of the coating on the zinc, to a sufficient extent, insoluble, while the light parts, being protected by the negative, can be dissolved out by a suitable solvent in the case of bitumen, or washed off if the albumen method is used. The drawing is thus left on the zinc in bitumen, and, as that substance is a good protective against acid, the plate is etched as already described.

There are also several gelatine processes, one or two of which may be shortly described. In the *swelled gelatine* process a plate of glass, coated with a film of bichromatised gelatine, is exposed under a negative, from a line drawing, and afterwards soaked in cold water, when the parts not acted upon by the light will swell up sufficiently to allow of a cast being taken which will give the lines in relief, or, if the plate be put in *hot* water, will be removed altogether, leaving the lines in relief. Or, if a photo-*positive* be put on the film, the lines will be left soluble and may be dissolved out by hot, or swelled up by cold water. In these gelatine processes, however, the relief is very low, and the white parts have to be made up with heated wax by hand, which is a very delicate process, or cut away in a subsequent stereotype. In some methods a solid slab of prepared gelatine is used, when the etching or dissolving out may be made as deep as required.

There are an infinity of other slightly differing processes for producing the same result, but as they are all more or less founded on the same principle, they do not call for separate description.

The production of relief blocks from ordinary photographs or drawings made by washes of black and white is a much more delicate matter. Intaglio plates have indeed been in successful use for many years (see PHOTOGRAVURE), but relief blocks until the invention of Meisenbach's process baffled all efforts. As in relief block every part which touches the paper prints *black*, and every part which does not touch the paper leaves it *white*, it is obvious that until some method was devised of turning the smoothly graded tones of a photograph into something which could be represented in pure black and white, success was impossible.

The method sought after was to break up the photo-tones into some sort of grain, stipple or line,

which should be closest in the darkest parts, and become more open as the lights were approached. It would be unadvisable, even if it were possible, to enumerate all the devices which have been invented and patented for this purpose. That patented by Meisenbach of Munich in 1882, however, as the one on which nearly all the most successful subsequent processes are based, may be briefly explained. A glass plate is prepared with fine parallel lines, thus . This is exposed between the lens and the sensitive plate in the camera, at a very short distance from the plate, and when the exposure is half completed the cap is put on the lens, the lined plate is taken out and put in with the lines in the reverse direction, thus , and the exposure is completed. The resultant negative is thus broken into minute regular dots. These 'screens' are now prepared with cross lines, thus avoiding the necessity of changing the position during exposure. They are glass plates with etched lines, or are photographically printed from a plate so prepared—two plates being fastened face to face with their lines in opposite directions to give the cross effect. The lines may vary in width from 85 per inch for newspaper printing, to about 150 per inch for fine printing. Plates with 200 per inch produce work so very fine in grain that special printing is required.

A *grained* photograph being finally obtained by means of any of the thousand-and-one processes, it is transferred to zinc and etched as described for the line process.

In addition to these photo-chemical processes, there are several mechanical methods of producing relief blocks, of which Messrs Dawson's Typo-etching process, an improvement upon Palmer's Glyphographic process (patented in 1848), is very extensively used for the production of maps, plans, diagrams, &c. A polished brass plate is covered with a film of prepared wax, on which the lines are drawn with special etching needles which clear away the wax down to the metal. Letters and words are stamped through the wax with types of varying sizes as may be required. The wax, which is of course very thin, is added to by melting other wax over the surface with a heated pointed metal tool. This stream of melted wax is skilfully prevented from running into the lines or letters, and when thick enough to give sufficient depth to the finished block, an electrotype is taken from the plate, in which the cleared surface of the brass forms the raised lines, and the built-up wax the sunk or white parts. This electrotype is the printing block. Many of the text maps in the present work are executed by this process: those in Vol. VI. p. 701, and Vol. VII. p. 762, are good examples.

Many other mechanical methods are used in engraving and etching, but generally they are too technical to be detailed here, and we have described nearly all which are of any public consequence.

It is obvious that these various processes, though simple enough in theory, give great scope for skill in manipulation, and much of their success depends on the ability of the operator. As a means of illustrating books they are making rapid strides towards complete success within the bounds, not by any means unlimited, of their capabilities. The rapidity with which they can be produced has rendered the daily illustrated paper a possible and accomplished fact. As to cost, blocks can be produced for from 4d. to 1s. 6d. per square inch of surface, according to the nature of the drawings, the stipple process being the more expensive.

The first and most important requisite is to obtain drawings suitable for the purpose, and these should be made by artists who have studied the capabilities and requirements of the various methods,

For the line processes the drawings, when not executed on transfer paper, should be made on bristol board or smooth-surfaced white paper, with some dense black pigment, as much of the success depends on the sharpness and blackness of even the faintest lines. Stephen's ebony stain, Winsor & Newton's liquid lampblack, and other pigments have been used for the purpose. The drawings should be larger than the required reproduction, as the reduction tends to refine the block, and care should be taken to see that every detail is exactly as wanted, for the process reproduces the defects as strongly as the beauties of a drawing. Given proper drawings and subjects suitable for the purpose, this process undoubtedly is capable of producing first-class work.

The stipple or Meisenbach process is a much more delicate affair, and from the care with which its blocks require to be printed, on account of the necessarily shallow nature of the etching, its application is much more limited. If nature photographs are reproduced on too small a scale, the stipple, if coarse, obliterates much of the detail, and, if too fine, is apt to blur in printing. But when drawings are specially made for it by artists who understand its requirements, it is capable of very fine results, and the drawing is reproduced with a fidelity seldom seen in an engraving. The drawings may be executed in lampblack and Chinese white, or any pure monochrome.

This process has been so improved and developed that it has become almost the universal medium for ordinary book illustration.

The weak point of nearly all tone-process work is that the sharpness and brilliancy of the original drawing gets softened and generalised away, and the result is sometimes flat and spiritless, with a tendency to become monotonous. The process has no *white*; even the highest lights are covered with tint. This difficulty is met by an increasing use of hand engraving on the blocks, in order to restore the vigour of the drawing, and to give something more or less like a good wood engraving.

The latest development of the process is the *Three-Colour Process*. Coloured pictures, or naturally coloured objects, are by this method reproduced and printed by means of three blocks, printed with red, yellow, and blue inks respectively. It is founded on a suggestion by the late Clerk Maxwell, and Professor Vogel of Berlin and many others have helped in its development. By means of coloured screens, or *light-filters*, three separate negatives of the subject are taken, reproducing the colour values of the yellow, red, and blue rays respectively. These negatives are by the usual process made into blocks, which, if properly printed with the correctly coloured inks, produce a more or less exact facsimile of the original object or drawing. Many very fine examples of the process have been produced, in which every touch of the brush in a water-colour drawing has been faithfully reproduced. The care and delicacy necessary for successful printing, however, is very great, and the method should be limited to cases where specially prepared paper can be used in printing, or the result may be disappointing.

For purely photographic methods of illustration, such as colotype, see PHOTOGRAPHY.

See *The Process Year-Book* (annually); W. Savage, *Practical Hints on Decorative Printing* (Lond. 1824); *Paper on Illustrated Books in Quarterly Magazine*, vol. lxxiv. (June 1844); H. Bouchot, *The Printed Book, its History, Illustrations, &c.* (Eng. ed. by E. C. Bignone, Lond. 1887; new ed. 1889); J. S. Hadou, *Traité de Art Illustration* (1884); *Modern Methods of Illustrating Books* (Lond. 1887); Joseph Pennell, *Pen Drawings and Pen Engravings* (1889; new ed. 1894); and *Modern Illustration* (1896).

Illyria (Lat. *Illyricum*), in ancient times the country that stretched along the eastern side of the Adriatic Sea, from Epirus northwards. It was not a homogeneous territory, but varied in extent at different periods of its history. The region was inhabited by numerous tribes, who seem seldom to have been held together by any sort of political cohesion. From some cause or other—probably the mountainous character of the region they inhabited was the principal cause—they were the last of the peoples of the Balkan peninsula to be brought within the fold of civilisation. The single Greek colony of Dyrrhachium or Epidamnus, in the south, was the only point whence the rays of Greek enlightenment could penetrate the darkness of Illyrian barbarism. The Illyrians are described as resembling the savage Thracians in their manners, as tattooing their bodies, as offering human sacrifices to their deities, but as honouring women, who even held chieftainships amongst them. For many years they seem to have kept up a series of incessant attacks upon the early kings of Macedonia; they levied tribute from Amyntas II., and slew Perdiccas (359 B.C.). But they were subdued by Philip II. and Alexander, who annexed their country to Macedonia. In the 3d century, after the breaking up of the Macedonian monarchy, they caused much annoyance to Greece and Italy by their piratical excursions. At length the patience of Rome was exhausted, and in two short wars (229 and 219 B.C.) she succeeded in subjugating the refractory Illyrians. Fifty years later they provoked a third war with Rome, which resulted in their defeat and the incorporation of their territories in the all-victorious republic. Nevertheless, the Illyrians only consented to be civilised at the sword's point, they frequently rose in revolt against their conquerors; but in 35 B.C. Illyria was made a Roman province. During the empire they served faithfully in the Roman armies, and even gave half-a-dozen emperors to the state, as Claudius II., Aurelian, Diocletian, Probus, and some others. Under the rule of the emperors the political importance of Illyria, or Illyricum, as the Romans called it, was greatly increased. In the 2d century Illyria extended as far north as the Danube, and even beyond it, and included Noricum, Pannonia, Moesia, Thraee, and Dacia. Constantine still further enlarged its boundaries, and made it one of the four chief divisions of his empire. But when the empire was divided between East and West, Illyria was also divided, Noricum, Pannonia, Moesia, &c. were designated as Illyris Barbara, and incorporated with the empire of the West; Illyris Græca, embracing Greece, Macedonia, Epirus, &c., was attached to the eastern empire. In the period of the final dissolution of the western empire Illyria was successively overrun by the Goths, the Huns, and several Slavic tribes, and nearly all traces of civilisation disappeared. The Illyrians themselves partly amalgamated with the Huns and their Slavic conquerors, and partly were driven southwards, where one of their tribes, the Albani, survive, at all events in name, in the modern Albanians. As the several Slavic states became consolidated and rose to power, the political importance of Illyria, and even its name, gradually died away. The name was revived in quite modern times, when Napoleon, in 1809, turned the territories he had wrested from Austria into the Illyrian provinces. In 1816, when they were restored to Austria, this power constituted out of them and the provinces of Carinthia, Carniola, Gorz, Gradisca, and Istria the kingdom of Illyria. But the designation was dropped in 1849, and the territories included in it were reorganised as provinces.

The geographical features of Illyria are described under BOSNIA, DALMATIA, MONTENEGRO, &c., the modern states or provinces with which it most nearly coincided.

The name Illyrian is also used in three other significations. In the 17th and 18th centuries it was used to indicate those Slavs who were members of the non-united Greek Church—i.e. principally the Servians or Razans. In the 19th century the terms Illyrian and Illyrian peoples were used in connection with the idea of the union of the Southern Slavs—the Servians, Croats, and Slovenians—into a revived Illyrian kingdom, an idea which seems to have been first made current by Gaj about 1835. Illyrian literature is sometimes used when Servian literature is meant; and Servian literature in this sense includes Dalmatian or Ragusan literature. See SERBIA, and RAGUSA. The scene of Shakespeare's *Twelfth Night* is laid in Illyria.

Imen (formerly *Mosk*), a lake in the Russian government of Novgorod, with an area of 354 sq. m., and a depth varying from 7 to 30 feet. The rivers Shelon, Lovat, Msta, and several others flow into the lake, which discharges its waters through the river Volkhof into Lake Ladoga. The lake abounds in fish.

Ilminster, an ancient market-town of Somersetshire, is situated on the Isle, 11 miles SE. of Taunton by rail. The church is a noble example of Perpendicular architecture. Some manufactures of ropes, bricks, and tiles are carried on. Pop. of parish (1831) 2957; (1891) 3135.

Il Obeid. See OBEID.

Ilori, or ILLORIN, capital of a Yoruba state in western Africa, and a great commercial centre, stands at an elevation of 1300 feet, about 160 miles NNE. from Lagos (on the coast). The people, 70,000 in number, consist of Yorubas, Hausas, Fulah, and others, and make cloth, arms, and leather. The state is now practically a province of the empire of Sokoto (q.v.); and is within the territory of the British Royal Niger Company. The religion is Mohammedanism, with strong traces of heathenism.

Ilsey, EAST, or MARKET HULSEY, a market-town of Berkshire, situated amid bleak and dreary downs, 9 miles N. of Newbury and 6½ S. of Didcot. Its sheep-markets count among the most important in the kingdom. Pop. 577. Archbishop de Dominis was rector of West Ilsey, 2 miles north-west. Pop. 377.

Image. See LENSES, MIRROR.

Image-worship (Gr. *εἰκονολατρεία*), the use in public or private worship of graven or painted representations of sacred persons or things, and especially the exhibition of honour, reverence, or worship to or towards such representations. Neither in the New Testament nor in any genuine writings of the first age of Christianity can any trace be discovered of the use of statues or pictures in the worship of Christians, whether public or private. The earliest allusion to such representations is found in Tertullian, who appeals to the image of the Good Shepherd as engraved upon the chalices. A very curious pagan caricature of Christianity of the same age, lately discovered scratched upon the wall of a room in the palace of the Cæsars (see GRAFFETTI), which rudely represents a man standing in the attitude of prayer, with outstretched hand, before a grotesque caricature of the crucifixion, and which bears the title 'Alexamenus worships God,' has been recently alleged by Catholics as an additional indication of at least a certain use of images among the Christians of the 2d century. The tombs of the Christians in the

Roman catacombs, many of which are of a date anterior to Constantine, frequently have graven upon them representations of the Dove, of the Cross, of the symbolical Fish, of the Ship, of Adam and Eve, of Moses striking the rock, of Jonah, of Daniel in the lions' den, of the apostles Peter and Paul, and above all, of the Good Shepherd; and those compartments of the catacombs which were used as chapels are often profusely decorated with sacred representations, the age of which, however, it is not easy to determine with accuracy. It is admitted by Catholics, however, that, from the fear of perpetuating idolatrous notions, for the first three centuries the use of images was rare and exceptional; nor was it until after the establishment of Christianity under Constantine, and particularly after the condemnation of the Nestorian heresy in 430, that statues and pictures of our Lord, of the Virgin Mary, and the Saints, were commonly introduced in churches, especially in the East and in Italy. And yet even in the 5th century the practice had already reached a great height, as we learn from the church historian, Theodoret, for the East, and from Paulinus of Nola, for Italy; and in the 6th and 7th centuries many popular practices prevailed which called forth the condemnation of learned and pious bishops both in the East and in the West. It was usual not only to keep lights and burn incense before the images, to kiss them reverently, and to kneel down and pray before them, but some went so far as to make the images serve as godfathers and godmothers in baptism, and even to mingle the dust or the colouring matter scraped from the images with the eucharistic elements in the Holy Communion! This use of images by Christians was alleged as an obstacle to the conversion of the Jews, and as one of the causes of the progress of Mohammedanism in the East; and the excesses described above provoked the reaction of Iconoclasm (q.v.). In the second Council of Nice (787) the doctrine as to the worship of images was carefully laid down. A distinction was drawn between the supreme worship of adoration, which is called *latreia*, and the inferior worship of honour or reverence, called *douleia*. The second Council of Nice declared that the worship to be paid to images is not the supreme worship of *latreia*, but only the inferior worship of *douleia*; and also that it is not *absolute*, and is not rendered to the images themselves, but *relative*—i.e. only addressed through them, or by occasion of them, to the original which they represent. A strange error in the translation of the Greek acts of the Council of Nice, by which it appeared that the same adoration was decreed by that council to images which is rendered to the Holy Trinity itself, led to a vehement agitation in France and Germany under Charlemagne, and to a condemnation by a synod at Frankfort of the doctrines of the Council of Nice. But an explanation of this error, and of the false translation on which it was based, was immediately afterwards given by the pope; and eventually the Nicene exposition of the doctrine was universally accepted in the Western as well as in the Eastern Church.

At the Reformation the reforming party generally repented the use of images as an unscriptural novelty, and stigmatised the Catholic practice as superstitions and even idolatrous. The Zwinglian, and subsequently the Calvinistic churches entirely repudiated all use of images for the purposes of worship. Luther, on the contrary, while he condemned the Roman worship of images, regarded the simple use of them even in the church for the purpose of instruction and as incentives to faith and to devotion as one of those *anaphoric*, or *adjuvant* things, which may be permitted, although not of necessary institution; hence, in the

Lutheran churches of Germany and the northern kingdoms, pictures, crucifixes, and other religious symbols are still freely retained. In many of the parish churches of England these remained till long after the Reformation. Thus, we find that William Dowling found ample employment during ten months of 1644 in destroying pictures and images in the churches of the single county of Suffolk, in accordance with an ordinance of parliament. In the modern Anglican Church the practice is still a subject of controversy, and the magnificent sculptured reredos erected in St Paul's Cathedral was protested against as idolatrous by some of the London clergy in 1888. In the Presbyterian Church and in all the other Protestant communions images are entirely unknown, although figures of patron saints and eminent churchmen have occasionally been set up, as in the restored St Giles' High Kirk in Edinburgh.

The Roman Catholic Church, through the decree of the Council of Trent, disclaims the imputation commonly made against Catholics of the idolatrous worship of images, 'as though a divinity dwelt in them, or as though we [Catholics] asked anything of them, or trusted in them, as the heathens did in their idols.' It renews the Nicene distinction between *absolute* and *relative* worship; the latter of which alone 'whereby we worship Christ and the saints, who are the prototypes of these images'—it sanctions or permits; and it contends for the great advantage, especially in the case of rude and unlearned people, to be drawn from the use of pictures and statues in the churches as 'memorials of the sufferings and of the mercy of our Lord, as instructive records of the virtues of the saints, and exhortations to the imitation of their example, and as incentives to the love of God and to the practice of piety' (Sess. xxv. *On the Invocation of Saints*). In many foreign churches, especially in Italy, in southern Germany, and in France, are to be found images which are popularly reputed as especially sacred, and to which, or to prayers offered before which, miraculous effects are ascribed. But instructed Catholics declare that the legends connected with such images form no part of Catholic belief. Most Catholic books of instruction contain cautions against attributing such effects to any special virtue of the images themselves, rather than to the special faith, trustfulness, and fervour which are stirred up by their presence, and by the recorded examples of the mercy of God with which they are associated. For the modern Greek usage, see ICONOCLASTS.

Imago. See INSECT.

Imâm, or IMAM, the officer who in Mohammedan mosques recites the prayers and leads the devotions of the faithful. In Turkey the imâm also performs the ceremonies connected with circumcisions, marriages, and funerals. The prophet Mohammed and his immediate successors bore the title Imâm, because they used personally to conduct the devotions of their followers. Hence the title came to mean head of the faith, and as such is borne by the Sultan of Turkey. For 'the Hidden Imâm,' see ISMAILIS, MAHDI.

Imatra Falls. See FINLAND.

Imbecility. See IDIOCY.

Imbros, or IMBROS, an island of the Egean Sea, belonging to Turkey, about 14 miles N.E. of Lemnos and the same distance W. of the mouth of the Dardanelles. Area, 98 sq. m.; pop. 6000, mostly of Greek descent. The island is mountainous, its highest summit attaining 1950 feet above sea-level. Goats and bees are kept. The inhabitants cultivate the soil and carry on fishing. The chief village, Kastor, is situated on the north coast, and occupies the site of the ancient Thos.

of Imbros. It is the seat of a metropolitan of the Greek Church.

Imeritia, or IMERTITHA. See GEORGIA.

Imitatio Christi, a famous book highly prized by devout Christians of all confessions, and translated into more languages than any book except the Bible. The question of its authorship has given rise to a great controversy. It was formerly attributed unhesitatingly to Thomas à Kempis, and the best authorities still regard it as his work. But it has been claimed for Chancellor Gerson (q.v.), for Gerson, abbot of Vercelli (an apparently hypothetical person), for Walter Hilton, a monk of Sheen in Surrey, for Bonaventura, Bernard of Clairvaux, and for many other writers, both famous and obscure. See KEMPIS (THOMAS A.).

Imitation, in the science of musical composition, is the repeating of the same passage, or the following of a passage with a similar one, in one or more of the other parts or voices, and it may be either strict or free. When the imitated passage is repeated note for note, and every interval is the same, it is called strict, and it may take place in the unison or octave, or in any other of the degrees of the scale, either above or below the original passage. Canon (q.v.) is strict imitation carried on to some length. The progression of a passage may also be imitated by an inversion, or by reversing the movement of the original; also by notes of a greater or of a lesser value (see AUGMENTATION).

Imitation. See MIMICRY.

Immaculate Conception. The Feast of the Immaculate Conception of the Blessed Virgin Mary is celebrated on the 8th of December in the Latin, and on the 9th in the Greek Church, in which latter church it is held under the name of 'The Conception of St. Anne, the mother of the Virgin Mary.' The festival of the Conception itself is traceable in the Greek Church from the end of the 5th century, and in the Latin dates from the 7th; but a great controversy prevailed for a long time in the West as to whether and in what sense the conception of the Blessed Virgin Mary was to be held immaculate, and in what sense the Blessed Virgin herself was to be held conceived without sin. It was believed to be a consequence of the doctrine of the divine maternity, and a necessary part of the honour due to the Incarnation, that the Blessed Mother should be held to have been at all times free from the stain of sin. This might have been either by her having been, like the prophet Jeremiah (Jer. i. 6), or the Baptist St. John (Luke, i. 35), sanctified before her birth;—i.e. purified in her mother's womb from the stain of original sin; or by the still higher sanctification of having been entirely exempted from the stain of sin, either before the formation of the embryo in the womb of her mother, or at least before its animation by union with the soul. The actual controversy in the West may be said to have commenced with St. Bernard, who not only remonstrated with the canons of Lyons in 1131 for their unauthorised introduction of this festival in their cathedral, but rejected the opinion of the Blessed Virgin's having been conceived free from original sin, though he admitted her sanctification in her mother's womb. Duns Scotus, in a disputation held before the university of Paris in 1307, maintained the doctrine of the immaculate conception in its highest sense; and the entire order to which he belonged, the Franciscan, as well as the school to which he has given his name, the Scotists, afterwards zealously defended it. The Thomist school, which was that of the Dominican order, denied the immaculate conception, and much division for a time existed; but the prevailing tendency was at all times towards the Scotist opinion.

The university of Paris in 1387 condemned the Thomist doctrine. The Council of Basel—although, it is true, at the time when it was in conflict with the pope—declared the doctrine of the immaculate conception to be a Catholic dogma, and reprobated in the strongest terms the opposite opinion. Sixtus IV., however, imposed on the defenders of both opinions in 1470 the obligation of mutual toleration and charity, and renewed this constitution in 1483; but the university of Paris required from doctors graduating an oath that they would defend the dogma of the immaculate conception. The Council of Trent merely declared that 'in its decree on original sin it did not comprehend the blessed and immaculate Virgin Mary,' and renewed the constitution of Sixtus IV. This abstinence on the part of the council led to a further renewal of the dispute, which reached such a pitch towards the close of the 16th century that Pius V. not only prohibited either side from stigmatising the opposite with the name of heretical, but forbade all public discussions of the subject, except in theological disputations in the presence of a learned auditory. In the pontificates of Paul V. and Gregory XV. earnest requests were made by the Spanish crown to obtain a definite declaration in favour of the doctrine of the immaculate conception; but the pope again refused, contenting himself with repeating the constitution of Sixtus IV. He added, however, certain new provisions: (1) That disputants, in asserting the doctrine of the immaculate conception, should abstain from assailing the opposite doctrine. (2) That no one except the members of the Dominican order, and others specially privileged, should presume to defend, even in private disputation, the doctrine that the Blessed Virgin Mary was conceived in original sin. (3) That, nevertheless, in the public mass or office of the church, no one should introduce into the prayers or other formulae any other word than simply *conception*, without adding any epithet involving either doctrine. At the same time opinion was setting steadily in favour of the doctrine of the immaculate conception. Alexander VII. and afterwards Clement IX. added new solemnity to the festival. Clement XI. ordained that it should be observed as a holiday of obligation, and at length Gregory XVI. permitted that the epithet immaculate should be introduced into the public service. In the end, at the instance of bishops in various parts of the church, Pope Pius IX. addressed a circular to the bishops of each nation, calling for their opinion, and that of their people, as to the faith of the church on the point; and on the receipt of replies all but absolutely unanimous, he issued a solemn decree at Rome, in a numerous council of bishops, on the 8th December 1854, declaring the doctrine to be an article of Catholic belief, and proposing it as such to the universal church. This decree has been universally accepted throughout the Roman Church.

Immanence, the notion that the intelligent and creative principle of the universe pervades the universe itself, a fundamental conception of Pantheism (q.v.).

Immanuel. See EMMANUEL.

Immermann, KARL LIEBLECHT, dramatist and humorist, was born at Magdeburg on 24th April 1796, and educated at his native town and at Halle, where he opposed the duelling *Burschenschaften* (q.v.). In 1817 he entered the public service of Prussia, and, after serving at Munster, Magdeburg, and Dusseldorf, died at the last-named town on 25th August 1840. For twenty years of his life (1819-39) he was greatly influenced by the Countess von Ahlefeldt, an intellectual lady of literary tastes. Immermann began his

literary career as an adherent of the Romantic school, and in the spirit of that school wrote the comedies *Die Prinzen von Syrakus* (1821) and *Das Auge der Liebe* (1824), and the tragedies *Das Thal von Ronceval* (1822), *König Perintoler* (1823), and others. His later dramatic works, as the trilogy *Alexis* (1832) and the mythical piece *Merlin* (1831), show more originality and fewer traces of Romantic influence. He failed in an endeavour to make the theatre at Dusseldorf, of which he became director in 1835, a model of classic elegance and healthy influence. His fame rests more enduringly upon his tales (*Miscellen*, 1830) and the humorous, satirical novels *Die Epigonen* (1836) and *Mannchenhausen* (1839), (this last the best known of his works and one of the best of German novels. The idyllic portion of *Mannchenhausen* has often been printed separately under the title *Der Oberhof*). Besides these he wrote a mock heroic poem *Falschheit* (1827), the epic *Tristan and Isolde* (1842), and *Memnonbitten* (1840-43), the last two left incomplete. Collected editions of his works were published in 14 vols. (1840-43), and in 20 vols. by Boxberger (1883). See *Life* by his widow, edited by G. von Putlitz (2 vols. 1870).

Immigration. Under the head of Immigration (q.v.) the causes which have led to immigration and the conditions under which movements of population are conducted have been fully described. It is necessary under immigration (entering or passing into a place, as opposed to emigration) to touch on some features of national opinion and policy which have come into existence within the past few years. Until the last few years, with the exception of the immigration of Huguenot families from France to Great Britain after the revocation of the Edict of Nantes, the population of these islands has not been increased from external sources. Since 1880 a considerable influx of the Semitic inhabitants of eastern Europe, principally Polish, Russian, Roumanian, and German Jews, has seriously affected the industrial position of British-born workers in certain trades. Public attention was drawn to the subject in 1888 and 1889 by the appointment of two parliamentary committees, one by the House of Lords on the sweating system, the other by the House of Commons on the question of foreign pauper immigration. These separate inquiries were really directed to the same subject. From the evidence given it appears that the anti-Semitic laws of Russia, Poland, and Germany, aggravated by the hated burden of compulsory military service, have induced considerable bodies of destitute persons, almost exclusively of the Hebrew faith, to seek in England a refuge from civil and religious persecution. Unlike the Huguenots, who brought with them not only capital, industry, and a knowledge of at least two useful trades, silk-weaving and watch-making, the Jewish refugee families arrive in England in a destitute condition. The result of this indigent condition is a willingness to accept the smallest remuneration for the heaviest labour. Sixteen to eighteen hours a day is no unusual period of toil for these pauper immigrants in the boot-finishing trade. The weekly remuneration for this work varies from four to fourteen shillings, according to the skill and industry of the worker. The bearing of these facts on the welfare of British-born workers engaged in the same or in kindred occupations is of a sinister character. Alone of civilised nations Great Britain is without laws to control and if need be check the influx of foreigners, who, contributing nothing to the national revenue, enjoy the privileges without sharing the burdens of citizenship. Public opinion holds jealously to the traditions of hospitality England has always extended to refugees by foreign persecution. Mazzini, Kossuth, and Orsini found

a sanctuary on British soil. It is held that the humbler objects of foreign tyranny shall have no colder welcome measured out to them. The present position of the pauper immigrant question in Great Britain is set forth in the Report of the Select Committee of the House of Commons, 1889, and is to the effect that although no immediate legislation is recommended, the circumstances are such as to require careful watching, with the probability of some restrictive measure being required in the future.

Far otherwise has the question of immigration been dealt with in the United States. By an act passed by congress in 1882 (also the Undesirable Persons Act, 1891) it is provided that passengers arriving from foreign ports shall be subject to examination. If a convict, imbecile, idiot, or any person unable to take care of himself or herself without becoming a public charge be found on board, such persons shall not be allowed to land. In 1898, 3229 persons were sent back to their port of embarkation, 2812 under the above act of 1891, and 417 under the Contract Labour Acts mentioned below. Of the total, 312 were British and Irish. The liability to repatriation acts as a deterrent to the embarkation of persons likely to come under the act. The importation of foreigners and aliens is prohibited in certain cases. By the Alien Contract Labour Laws (1885, 1887, 1888, and 1891) prepayment for transportation of or assisting foreign immigrants under contract for labour or service made previous to emigration, is declared to be unlawful. Any contract so made is void and of no effect. Foreigners temporarily residing in the United States are nevertheless permitted to engage other foreigners as private secretaries, servants, or domestics. Nor are persons prevented from engaging as skilled labourers foreigners in any new industry not established in the United States. The provisions of this act do not apply to professional actors, artists, lecturers or singers, nor to persons employed strictly as personal and domestic servants, nor do they prevent any individual assisting his friends or relatives to emigrate to the United States for the purpose of settlement.

The restriction of the immigration of the Chinese into the United States dates from the completion of the great trans-continental railways. Thrifty, abstemious, and industrious, the Mongolian labourers threatened to lower the wages of the Irish and the native-born Americans. The case for the exclusion of Chinese includes the following points: (1) That they arrive in the country faster than any other kind of immigrant; (2) that the number of Chinese is greater than that of any other race; (3) that they are indisposed to be governed by white men's law; (4) that they are dissimilar in habits and occupation to the English speaking races; (5) that they evade the payment of taxes justly due to the government; (6) that they are governed by pestilential habits; (7) that they are useless in cases of emergency; (8) that they habitually desecrate graveyards by the removal of bodies therefrom; (9) that the laws governing the whites are found to be inapplicable to the Chinese; (10) that they are inclined to habits subversive of the comfort and well being of the community; (11) that they do not come as permanent settlers. To carry out the measures for excluding the Chinese a treaty was concluded between the United States and China in 1880, which was proclaimed the following year. The first and most important article of this treaty stipulates that whenever in the opinion of the government of the United States the coming of Chinese labourers affects or threatens to affect the interests of that country, or to endanger the good order of the said country, or of any locality

within the territory thereof, the government of China agrees that the government of the United States may regulate, limit, or suspend such coming or residence, but may not absolutely prohibit it.' In pursuance of the stipulations in the above treaty congress passed in May 1882 an act declaring that, 'in the opinion of the government of the United States the coming of Chinese labourers to this country endangers the good order of certain localities within the territory thereof,' and it is enacted that the immigration of Chinese labourers be suspended for ten years, and during that time it shall not be lawful for a Chinese labourer to come, or, having come, to remain in the United States. No Chinese are or can be admitted to citizenship. The laws and regulations devised to secure the exclusion of the Chinese are exceedingly stringent. Any person bringing, or causing to be brought, any Chinese person not lawfully entitled to enter the United States is guilty of a misdemeanour, and shall on conviction be fined not exceeding \$1000, and imprisoned for not exceeding one year. Masters of vessels arriving at United States ports must supply to the collector of customs a separate list of Chinese passengers on board. Any refusal or wilful neglect to comply with these provisions subjects the master to the penalties provided for refusal to deliver a manifest of cargo.

Public opinion in the United States is by no means unanimous on the Chinese question. The pressure, however, of the Pacific states has been too strong for resistance by the Atlantic states.

With regard to the laws and regulations prevailing in the larger British colonies, space will not permit their being set forth in detail. The following précis of facts and references will be found useful for further investigations of the subject:

Laws or regulations, if any, in the large colonies prohibiting or restricting the immigration of pauper or infirm persons:

Canada.—See chap. 65 of revised Statutes of Canada, 1886, sections 17 to 24.

New South Wales.—No statute.

Victoria.—Sections 36-39 of Passengers, Harbours, and Navigation Statute, 1865.

South Australia.—The governor has power under the Immigration Act to make rules for repatriating pauper and infirm persons.

Queensland.—No statute.

Tasmania.—Section 3, 49 Viet. No. 4, 1885.

New Zealand.—Imbecile Passengers Act, 1882.

Cape.—No statute.

Natal.—No statute.

The laws of foreign countries respecting the admission and continued residence of destitute aliens are contained in a return presented to parliament in September 1887 (c. 5168, Eyre & Spottiswoode).

The law of the Australasian colonies relating to the Chinese are substantially the same as those prevailing in the United States. See CHINA, Vol. III. p. 193; and COOLIES.

Immorality, in point of law, is a good defence to actions and suits, and obligations and contracts made against good morals are ineffectual at law. Thus, for example, if a man gave a bond, or granted a deed, giving to a woman some annuity, with a view to induce her to live in concubinage, this would be a good defence against the bond or deed being enforced, for the law discountenances his conduct; whereas, if it were merely a bond, or a gift, in consideration of something of the same kind past and ended, the deed would be good. So the keeper of a house of ill fame is not allowed to sue, and has no legal remedy against her guests for any sum agreed to be paid for immoral purposes.

Immortality is the continued existence of the human soul in a future and invisible state. 'If a man die, shall he live again?' is a question which

has naturally agitated the heart and stimulated the intellectual curiosity of man, wherever he has risen above a state of barbarism, and commenced to exercise his intellect at all. The religion of all civilised peoples may be said more or less to recognise the affirmative of the question, although often under very vague and materialistic forms. Some of the most widely-spread forms of belief in the world would seem to be exceptions to this statement; for in Hinduism the goal sought is absorption into the Universal Spirit, and therefore loss of individual existence; while the pious Buddhist strives for *Nirvana*, or complete extinction. Yet even here the belief in a future life exists in the form of Transmigration (q.v.).

In the ancient Egyptian religion the idea of immortality first assumes a definite shape. There is a clear recognition of a dwelling-place of the dead and of a future judgment. Osiris, the beneficent god, judges the dead, and 'having weighed their heart in the scales of justice, he sends the wicked to regions of darkness, while the just are sent to dwell with the god of light.' The latter, we read on an inscription, 'found favour before the great God; they dwell in glory, where they live a heavenly life; the bodies they have quitted will for ever repose in their tombs, whilst they rejoice in the life of the supreme God.' Immortality is plainly taught, but bound up with the idea of the preservation of the body, to which the Egyptians attached great importance, as a condition of the soul's continued life; and hence they built vast tombs, and embalmed their bodies, as if to last for ever. In the Zoroastrian religion the future world, with its governing spirits, plays a prominent part. Under Ormuzd and Ahriman there are ranged regular hierarchies of spirits engaged in a perpetual conflict; and the soul passes into the kingdom of light or of darkness, over which these spirits respectively preside, according as it has lived on the earth well or ill. Whoever has lived in purity, and has not suffered the *daes* (evil spirits) to have any power over him, passes after death into the realms of light. In the early Greek paganism Hades, or the realms of the dead, is the emblem of gloom to the Hellenic imagination. Achilles, the ideal hero, declares that he 'would rather till the ground than live in pale Elysium.' This melancholy view of the future everywhere pervades the Homeric religion. With the progress of Hellenic thought a higher idea of the future is found to characterise both the poetry and philosophy of Greece, till, in the Platonic Socrates, the conception of immortality shines forth with impressive clearness and precision. In the *Apology* and the *Phædo* Socrates discourses of the doctrine of the soul's immortality in language at once rich in faith and in beauty. 'The soul, the immaterial part, being of a nature so superior to the body, can it,' he asks in the *Phædo*, 'as soon as it is separated from the body, be dispersed into nothing, and perish? Oh, far otherwise. Rather will this be the result. If it take its departure in a state of purity, not carrying with it any clinging impurities of the body, impurities which during life it never willingly shared in, but always avoided, gathering itself into itself, and making the separation from the body its aim and study—that is, devoting itself to true philosophy, and studying how to die calmly; for this is true philosophy, is it not?—well, then, so prepared, the soul departs into that invisible region which is of its own nature, the region of the divine, the immortal, the wise, and then its lot is to be happy in a state in which it is freed from fears and wild desires, and the other evils of humanity, and spends the rest of its existence with the gods.'

It is only in Christianity, however, that this higher life is clearly revealed as a reward, not

merely to the true philosopher, but to every humble and pious soul. Christ 'hath brought life and immortality to light by the gospel.' 'According to his abundant mercy, God hath begotten us again unto a lively hope by the resurrection of Jesus-Christ from the dead, to an inheritance incorruptible and undefiled, and that fadeth not away, reserved in heaven.' It is undoubtedly owing to Christianity that the doctrine of the soul's immortality has become a common and well-recognised truth—no mere result of speculation, nor product of priestly invention—but a light to the reason, and a guide to the conscience and conduct. For the Old Testament view see the article HELL; for other questions connected with the future state see the articles ANIMISM, APPARITIONS, CONDITIONAL IMMORTALITY, HEAVEN, ESCHATOLOGY, ORIGIN, PRE-EXISTENCE, SOUL, SPIRITUALISM, THEOSOPHY, UNIVERSALISTS; also Salmon's *Christian Doctrines of Immortality* (1896).

Immortelles. See EVERLASTING FLOWER.

Imola, a town of Italy on an islet in the river Santerno, in the midst of a fruitful plain, 22 miles SE. of Bologna by rail, with manufactures of leather, pottery, silk, and glass. Its cathedral has been spoiled by restoration. Pop. 12,500. Innocenzo di Imola (properly Francucci), a notable painter, was born here in 1494, and did most of his life's work in Bologna, where he died about 1550.

Impanation (Lat. *in*, and *panis*, 'bread'), a technical word formed on the analogy of 'incarnation,' employed in eucharistic controversies as early as the 12th century to express the union of the body of Christ with the consecrated bread in the Eucharist; but later specially used of Luther's doctrine of Consubstantiation (q.v.). See LUTHER, and LORD'S SUPPER.

Impeachment, an exceptional form of process whereby the House of Commons may obtain redress for any unlawful act, and especially for high crimes and misdemeanours committed by peers and ministers of the crown. When the House has resolved on an impeachment certain of its members are deputed to go to the bar of the House of Lords, and there to present the charges they are prepared to support. At the trial the Lords as a body act as judges, the managers appointed by the Commons conduct the prosecution, and the accused may be defended by counsel. For a picturesque description of these proceedings, see Macaulay's *Essay on Warren Hastings*. A pardon by the crown may not be pleaded in bar of an impeachment; but after conviction and sentence the crown may pardon the offender. The last instance of an impeachment is that of Lord Melville in 1805. Impeachment is a form of trial, and is to be distinguished from proceedings by way of Bill of Attainder or Bill of Pains and Penalties. Parliament deals with such bills in its legislative and not in its judicial capacity. In the United States impeachment is a written charge brought by the House of Representatives to the Senate against a civil officer of the United States; or, in the several states, the accusation of an officer by the legislature to the senate of the state. The most famous trial of impeachment in the United States was that of President Johnson (q.v.) in 1868; and he was acquitted under the rule requiring a two-thirds vote of the members present to secure a conviction, the vote standing 35 for and 19 against conviction.

Impenetrability, one of the essential properties of matter, implies that no two bodies can at the same time occupy the same space. If a nail be driven into a piece of wood, it does not, properly speaking, *penetrate* the wood, for the fibres are driven aside before the nail can enter. If a vessel

be filled with fluid, and a solid body be then placed in it, as much water will run over as is equal in bulk to the solid body, in this way making room for it. The lightest gases are really as impenetrable as the densest solid; although, owing to their compressibility, it is not readily made apparent.

Imperative, CATEGORICAL. See KANT, and ETHICS.

Imperial Cities. See FREE CITIES.

Imperial Institute. The Imperial Institute of the United Kingdom, the Colonies, and India, designed to commemorate the jubilee of Queen Victoria (1887), aims at comprising complete collections of the products of the various parts of the British empire, a commercial intelligence department for the promotion of trade and industry, and a great school of modern oriental languages (opened in 1890). In 1890 some £450,000 had been subscribed for the purpose, at home, in Canada, Australia, and India. The foundation of the building costing £300,000 was laid by the Queen in 1887, and the Institute was opened by her on 10th May 1893.

Imperialism, in its original, and, perhaps, its widest sense, was expressed in the great designs of Charlemagne (q.v.). Regarded thus, it amounts to a scheme of undisputed sway over an extensive area of unbroken territory—autoeracy on a grand scale. In that sense we find imperialism in the traditional policy of the czars of Russia—a policy which is supposed to imply continuous expansion to the east. But imperialism, as it came to be known in connection with Germany, does not imply conquest or aggression or annexation of territory. In Germany the policy sprang from the Franco-German war, or rather from the events preceding it, and it meant simply the union, or remission, of the several German states and peoples under one head for purposes of offence and defence, and for certain fiscal and political purposes. As applied in the affairs of the United Kingdom we find imperialism with a twofold signification. It has been in use for a comparatively few years—since about 1878 or 1879—and is usually traced to Lord Beaconsfield (q.v.). That statesman was credited with large dreams of empire for the British crown, and one of his most memorable acts was to have the Queen proclaimed Empress of India. In connection with the British empire, the word imperialism may, however, be used as combining the interests of all the members of the group—the mother-country, the colonies, and dependencies—as distinguished from purely national, colonial, or local concerns. The character and design of such British imperialism are expressed more or less coherently in the schemes of the Imperial Institute and the Imperial Federation League (see COLONY). The term 'Imperial Parliament,' as now applied to the legislature at Westminster, is another expression of the same sentiment. See ABSOLUTISM, AUTOCRACY, CHAUVINISM.

Impetigo Contagiosa, a disease of the skin. It consists of crops of pustules, which may either be scattered or collected in groups. These pustules burst, dry up, and become covered with scabs or crusts of a yellow colour, not unlike little masses of candied honey. From beneath these crusts a purulent discharge commonly exudes; the crusts become thicker and larger, and the skin beneath them is red and raw. The disease is most common in childhood, and generally arises in ill-fed, ill-cared-for children; but it may be transmitted by contact to adults. The head and face are most commonly affected. Local treatment consists in removal of the crust by poulticing, and the application of white precipitate ointment. Attention must be paid to the general health; cod liver oil and other tonic medicines are often desirable.

Impey, SIR ELDON, born in 1732, was educated at Westminster, brought up to the bar, and sent out to Bengal as the first chief justice appointed under the Regulating Act of 1773. He landed in Calcutta, 19th October 1774, in company with his brother judges and the three members of council sent out from England under the same act. From the first Impey acted in harmony with the governor-general, Warren Hastings (q.v.); and in the following year presided at the trial of Maharaja Nand Kumar (Nuncomar), charged with forgery. Impey conducted the trial with fairness and patience; the prisoner, however, was found guilty by the jury, after an impartial charge by the chief justice, who sentenced him to death with the concurrence of a full court. In 1777 Impey was referred to as arbitrator between Hastings and General Clavering when the latter claimed the reversion of the post on Hastings' alleged resignation. Impey pronounced in favour of Hastings; thereby—as the governor-general afterwards acknowledged—saving his fortune, honour, and reputation. In 1779, however, a conflict occurred between the government and the court on a question of jurisdiction, which was only appeased by Impey accepting the chiefship of the Company's courts in addition to his own duties. In 1783 Impey was recalled, and impeached for his conduct in the case of Nuncomar. He was honourably acquitted; Pitt and Dunning and Thurlow all concurred in approving the whole of his conduct. In his retirement he continued to enjoy the friendship of good men. In 1803 he visited Paris, and was for a short time detained by the French government in consequence of the rupture of the peace of Amiens. He died in his house at Newick, near Brighton, 1st October 1809. Impey was a good scholar, both classical and oriental; as a judge he was industrious and free from corruption. His faults were vanity and a tendency to obscuritism.

See HASTINGS; *Life of Sir E. Impey*, by his son, E. B. Impey (1846); *The Story of Nuncomar*, by Sir J. E. Stephen (1885); and Mill's *British India*.

Impeyan. See PHEASANT.

Imphail, the native name of Manipur (q.v.).

Imphée, one of the names of Sorghum or Durra (q.v.).

Implement, in Scotch law, means fulfilment of a contract or decree of the court.

Impluvium. See ATRIUM.

Imponderable Substances, an epithet applied to light, heat, electricity, and magnetism at a time when they were universally considered as matter, in contradistinction to those substances which possessed sensible weight. See HEAT.

Imports and Exports. See BALANCE OF TRADE; also articles on GREAT BRITAIN and other countries.

Impotency. See MARRIAGE.

Impounding. See POUND.

Impressionism, the term applied to a modern school of art which, originating in France, is usually held to have been founded by Edouard Manet, and of which Claude Monet, Degas, Renoir, Pissarro, Sisley, and De Cusane are the best known members. The impressionists may be said to have first appeared before the public in the special exhibition of the works of Manet and his followers which was held in Paris in 1867; and in 1874 and 1876 collections of their works were brought together in the Boulevard des Italiens and in the galleries of Durand Ruel, who in 1882 organised an exhibition of their productions in London; while a series of works by Monet were shown in 1889 in the Goupil Gallery, London. The aim of the impressionists is to rid themselves

of the trammels of artistic tradition, and to look at nature—and portray her—in a fresh and original manner. They therefore strive to avoid such compromises and conventionalities of lighting, composition, &c. as have been frankly accepted by the art of the past, and to render with absolute truth their personal and immediate 'impressions' of nature. The members of the school accordingly separate themselves from the great so-called 'romantic' art of the last generation in France—the art of men like Corot, Decamps, Rousseau, and Daubigny—which is a legitimate and orderly development of the mighty art of the past; and though they have more kinship with these they are also to be distinguished from the *plein-air* painters of modern France, at whose head stands Bastien Lepage, and whose main aim is a careful and strictly scientific accuracy in their relative tones of colour. In their rejection of tradition and desire for a fresh, unconventional rendering of nature the impressionists are at one with the pre-Raphaelites of England; but, while the latter studied nature in a severely detailed and analytical manner, the former look on her in her large relations, and portray only such of her salient features as are visible on a cursory examination, and those they render by brushwork of the slightest, thinnest, and looest description. From the pre-Raphaelites the impressionists are still more definitely separated by their want of care for intellectual or emotional interest in their pictures. In the words of one of their ablest exponents, they hold that the eye of the painter 'should abstract itself from memory, seeing only that which it looks upon, and that as for the first time; and the hand should become an impersonal abstraction, guided only by the will, oblivious of all previous cunning.' In the works of most of the impressionists little selection of subject or care for beauty of colour, form, or expression is visible; and their art, touching as it would seem by an instinctive preference on some of the most unlovely aspects of 19th-century existence, dealing with the life of the jockey and the ballet-girl, and portraying the worst atrocities of modern costume, has frequently fallen into dire depths of ugliness and vulgarity. Certain points of resemblance to the aims and methods of the impressionists are to be found in the works of such able painters as J. M. Whistler and J. S. Sargent, and still more distinctly in those of several of the younger Paris-trained English painters who have exhibited in the Suffolk Street Gallery and in the Nineteenth Century Art Club. In 1889 several young English painters, styling themselves 'London Impressionists, and including B. and W. Sickert, T. Russell, P. W. Steer, and Francis Bate, held an exhibition in the Goupil Gallery, London; and a pamphlet by the last-named painter, *The Naturalist School of Painting* (2d ed. 1887), contains the best exposition of the aims of the English section of the school.

Impressment. See PRESSGANG.

Imprint. See BOOK, Vol. II, p. 303.

Imprisonment. Imprisonment is one of the three classes of punishment for crime, death and penal servitude being the other two. Under certain statutes the punishment of whipping also may be adjudged to juvenile offenders or persons convicted of assaults with violence. It has always been a power inherent in courts of justice to imprison for contempt of their authority, and until lately for non-payment of debt. In criminal proceedings a person may, by a warrant of a justice of peace or magistrate, be imprisoned before trial, provided the justice considers it is not a proper case for allowing bail; and though in minor offences an accused person may insist on being

discharged on tendering sufficient bail, yet in more serious crimes it is in the discretion of the justice to accept or refuse the bail tendered, and on his refusal application may be made to judges of the common law courts to accept bail. In Scotland, when such review is resorted to under the Criminal Procedure Act of 1887, or the Act to amend the Law of Bail, 1888, the court as a general rule leaves the prosecutor's discretion as to bail-ability untouched, and in England the same rule obtains. In both countries the supreme courts will interfere where the question is merely one of amount, or where malice or oppression on the part of the prosecutor is averred; but in Scotland, owing to the system of official as distinguished from private prosecution, such grounds are rarely advanced in support of an application for bail. Imprisonment may be with or without hard labour, or it may be solitary. Every prisoner sentenced to undergo a long term passes a period in solitary confinement, and it is in the power of prison governors to order a return to this, which is considered the hardest part of the term, for any gross breach of discipline. The statutory limit of imprisonment is two years. Penal servitude may be inflicted for life, or any shorter term, but in the case both of imprisonment and penal servitude the convict can at any time, and repeatedly within certain limits, apply to the Home Secretary in England, and to the Scottish Secretary in Scotland, for commutation or remission. The documents are forwarded to the judge who tried his case, and the secretaries are guided in their decision by the report which the judge furnishes. In the general case a fourth or a third is deducted from all terms of penal servitude as a matter of course where the convict has complied with prison rules. In police and other petty offences tried summarily at common law and under a variety of statutes, imprisonment is usually awarded with the option of a fine (discretionary in amount), excepting the case of theft; but all other offences tried before recorder and quarter sessions in England and the sheriff and jury in Scotland are visited with imprisonment, although in a few isolated examples statute gives an option. The unlawful detention of the person by any one, or 'false imprisonment' (in Scotland, 'wrongons'), constitutes a personal injury, and may be treated as a criminal or as a civil offence. When persons tried and convicted are afterwards proved to have been innocent, compensation may be awarded to them, along with a formal pardon.

The subject of imprisonment for debt is discussed at DEBT, Vol. III, p. 717.

Improper House. See NUISANCE.

Impropriation, the transfer to a layman of the revenues of a benefice to which the cure of souls is annexed, with an obligation to provide for the performance of the spiritual duties attached to the benefice. The practice of *impropriation* differs from the somewhat similar but more ancient usage of *appropriation*, inasmuch as the latter supposes the revenues of the appropriated benefice to be transferred to ecclesiastical or quasi-ecclesiastical persons or bodies, as to a certain dignity in a convent, a college, a hospital; while impropriation implies that the temporalities of the benefice are enjoyed by a layman. The practice of impropriation, and still more that of appropriation, as in the case of monasteries, &c., and other religious houses, prevailed extensively in England before the Reformation; and on the suppression of the monasteries all such rights were vested in the crown, and were by the crown freely transferred to laymen, or whose successors in title they have passed by descent and purchase. The spiritual duties of such benefices are discharged by a clergyman, who is

called a vicar, and who receives a certain portion of the emoluments of the living, generally consisting of a part of the glebe-land of the parsonage, together with what are called the 'small tithes' of the parish. A lay impropriator is rector of the parish; as such he has rights over the church of the parish, and is bound to keep it in repair.

Improvisatori, an Italian term, designating poets who without previous preparation compose on a given theme, and who sometimes sing and accompany their voice with a musical instrument. The talent of improvisation is found in races in which the imagination is more than usually alert, as among the ancient Greeks, the Arabs, and in many tribes of negroes. In modern Europe it has been almost entirely confined to Italy, where Petrarch, in the 12th century, introduced the practice of singing improvised verses to the lute; and down to the present day the performances of improvisatori constitute one of the favourite entertainments of the Italians. Far inferior to these are such improvisations as those of Theobald Hook, wonderful as they were. Women have frequently exhibited this talent in a high degree. Improvisation is by no means limited to brief poems of a few verses and of very simple structure, but is often carried on with great art, and in the form and to the length of a tragedy or almost of an epic poem. But such productions when printed have never been found to rise above mere mediocrity. It is worthy of notice that the greater number of the celebrated improvisatori of Italy have been born in Tuscany or the Venetian territory. Siena and Verona have been especially productive of them. Some of the principal are Scratino d'Aquila (1466-1500), Peretti (1680-1747), Metastasio (q.v.), who soon abandoned the art, Zucco (died 1764), Serio and Rossi (both beheaded at Naples in 1799), Gianni (pensioned by Bonaparte), and Tommaso Sgricci (1798-1836). The best-known *improvisatrices* are Maddalena Morelli Fernandez, also called Corilla Olimpica, the original of Madame de Staël's *Corinne* (died 1800), Teresa Bandettini (1763-1837), Rosa Taddei, Signora Mazzei (probably the first in point of talent), and more lately the Sicilian Giovannina Milli.

Imputation is one of the most common technical expressions in Christian theology. It is meant to denote the transference of guilt or of merit of punishment or reward. The doctrine of the imputation of sin, for example, is the doctrine which inculcates that all mankind are sharers in the fact and consequences of Adam's fall from innocence; and the correlative doctrine of the imputation of Christ's righteousness is that which inculcates that the merit or righteousness of Christ is transferred to those who believe in him, or, in other words, that they become sharers in his merit or righteousness. See COVENANT, ATONEMENT.

Inaccessible Island. See TRISTAN DA CUNHA.

Inagna. See BARBAMAS.

Inanition. See FASTING.

Inarching. See GRATING.

In Articulo Mortis, i.e. at the moment of death, a legal phrase used in connection with the execution of deeds by persons at the point of death. See WILL.

Incandescence. The hotter a body the greater the disturbance which its particles, always oscillating, set up in the surrounding ether, and the greater is the proportion of ether-waves of short length which are set up. Thus, as a body becomes progressively hotter it first becomes visible in the dark as a fog-gray object (platinum at 300° C., gold at 117° C., and iron, not quite free from rust,

at 377° C.—H. F. Weber), then ash-gray, then yellowish-gray, then faintly red, then red hot, orange, yellowish-white, white hot, and lastly, when there is at very high temperatures a preponderance of the more refrangible rays, it becomes bluish or even distinctly blue, as it seems the sun would appear were it not for our atmosphere (Langley). Incandescence is usually witnessed in solids; in liquids it is not known by sight; in gases we have examples in the hydrogen flame and in the condition of the air traversed by lightning or the electric arc. For incandescent Electric Lamps, see ELECTRIC LIGHT; and for the incandescent gas-light, see GAS-LIGHTING, Vol. V. p. 103.

Incantation, a formula of words said or more frequently sung for purposes of enchantment. The use of such is a persistent feature in sorcery from the earliest times, and we still find them used among savage peoples as spells or charms efficacious for the healing of sickness and the averting of danger, as well as for bringing on rain or invoking any other blessing that is much desired. No less common are malignant spells by means of which evil deities are induced to send sickness or death upon enemies, the darker and malignant side of magic being ever as present to the primitive mind as the beneficent. Such traditional formulas show a marvellously conservative fixity of form—a proof, if such were needed, of their real unreality and practical inefficiency, and that the whole has at no time been other than a dark and blind appeal to unknown forces, without the slightest glimmering of scientific ratiocination, and capable of no improvement. For the same reason ancient or foreign epithets, and terms not merely misunderstood but not understood at all, are often found to have been particularly efficacious, and we find medieval sorcerers in their formulas using transposed letters and artificial words, the traditional Jewish names of demons, as Asmodai and the like, and a gibberish of mixed Hebrew and Greek words more or less consciously confused. Even so late as 1830 in Lincolnshire two Gypsy girls were found using a book of navigation in the process of their fortune-telling. The history of such words as the Gnostic *Abraheas* (q.v.) and the medieval *Abrahadabra* (q.v.) throw great light on the methods of magicians from the earliest ages down to the time when their absurdities disappeared before the dawn of a true scientific method. But it was not merely among the less civilised peoples that such constant use of incantations was made. In ancient Egypt magic was worked into an elaborate system and ritual, and many formulas of such religious magic are preserved. Again, the Babylonians had a great wealth of set formulas by means of which they propitiated or expelled the malignant demons who swarmed around them. In the *Vedas* we constantly meet the *mantras*, corresponding exactly to the *mantram* of the Redskins and the *hordkins* of the Maoris. In the *Odyssey* the kinsmen of Odysseus sing "a song of healing" over the wound given him by the boar's tusk. In the *Kalevala* again we find the song that saves wounds; and nothing is more common in our European traditional folk-tales than the most startling miracles wrought by the repetition of snatches of rhyme. But indeed such traditional refrains are by no means yet extinct in the corners of the most civilised countries, used along with the modern and more legitimate methods of healing, and they even have a defensible use in the soothing effect that an act of faith has upon a simple mind. Thus in Scotland, according to a writer in the *New Statistical Account of Scotland*, "when a person has received a sprain it is customary to apply to an individual practised in casting the "wresting thread." This is a thread spun from black wool,

on which are cast nine knots, and tied round a sprained leg or arm. During the time the operator is putting the thread round the affected limb, he says, but in such a tone of voice as not to be heard by the bystanders, nor even by the person operated upon:

The Lord ride, and the foal slide;
He lighted, and he righted,
Set joint to joint, bone to bone,
And sinew to sinew,
Heal, in the Holy Ghost's name.'

Incarnation, the usual theological term for the union of the divine nature with the human in the divine person of Christ. The word *incarnatio* first occurs in the Latin version of Irenæus, and in the Greek fathers we find its equivalent *sarkosis* and *enanthropōsis*. See CHRIST, JESUS, and Otley's *Doctrine of the Incarnation* (1896).

Incas. See PERU.

Incendiarism. See ARSON, EPIDEMIC.

Incense, a perfume, the odour of which is evolved by burning, especially in religious worship. The incense at present in use consists of some resinous base, such as gum olibanum, mingled with odoriferous gums, balsams, &c. There is no regular formula for it, almost every maker having his own peculiar recipe. The ingredients are usually olibanum, benzoin, styrax, and powdered cascavilla bark. These materials, well mingled, are so placed in the censer or thurible as to be sprinkled by falling on a hot plate, which immediately volatilises them, and diffuses their odour through the edifice.

In the Catholic Church, both of the West and of the East, incense is used in public worship, more particularly in connection with the eucharistic service, which is regarded as a sacrifice; but such use is implicitly condemned by Tertullian, Lactantius, Augustine, &c., and seems not to have established itself till the 6th or at least the 5th century. In the Roman Catholic Church incense is used in the solemn (or high) mass, in the consecration of churches, in solemn consecrations of objects intended for use in public worship, and in the burial of the dead. There are also minor incensations of the celebrating bishop or priest and inferior ministers; of prelates, princes, and other dignitaries officially present at the service; and a general incensation of the whole congregation.

In the Reformed churches the use of incense was abandoned at the same time with other practices which have been laid aside by them as without 'warrant of Scripture.' It has been revived by some Ritualists, but was prohibited by the Archbishops of Canterbury and York in July 1899. See CENSER, FRANKINCENSE.

Incest (Lat. *in*, 'not,' and *castus*, 'chaste') is the marrying of a person within the Levitical degrees. In the old ecclesiastical law (now obsolete), and in Scotland, it comprehends cohabitation irrespective of marriage. The law of England, as declared by statutes passed in the reign of Henry VIII., forbids marriage within the prohibited degrees (see CONSANGUINITY). A marriage between a widower and his deceased wife's sister comes within these rules, and is void, and it makes no difference that the marriage was celebrated in a foreign country, as, for example, Denmark, in the United States, or in one of the British colonies, where these marriages are legal, if the parties were domiciled in England, and went abroad merely to evade the English law. It has also been decided in England that the same rules which apply between legitimate relations apply between natural relations, though one is legitimate—as, for example, between a man and the daughter of an illegitimate sister of his deceased wife. Though incestuous marriages are utterly void in England, still it is not a criminal

offence to marry incestuously, not even in those cases in which the connection is most abhorrent to the moral sense of mankind, and the remedy in the ecclesiastical courts may be considered obsolete. In Scotland incest, which is calculated on the same grounds, not only makes a marriage void, but the better opinion is that to marry incestuously, as well as to commit incest, is a capital offence. See MARRIAGE.

Inch. a Gaelic word, corresponding to Irish *innis*, and signifying Island (q.v.); the same root appears in Lat. *ins-ula*. Inch and Innis enter into many compounds, as Inchemahome (an island in the Lake of Menteith), Inniscattery (an island in the estuary of the Shannon), &c.

Inchbald. ELIZABETH, actress, dramatist, and novelist, was the daughter of John Simpson, farmer at Standingfield, Bury St Edmunds, where she was born on 15th October 1753. While quite a girl she determined to become an actress, and when only eighteen left her home to seek a theatrical engagement in London. After a series of strange adventures she betook herself to her relations in London, and with them she met Joseph Inchbald, an obscure actor, whom she married on 9th June 1772. She then went to Bristol, where she made her debut as Cordelia on 4th September 1772; and for some years she played in provincial theatres. Her husband died suddenly in 1779, and in 1780 (3d October) she appeared in London, playing Bellario in *Philaster*, at Covent Garden. Here she remained for nine years, but never rose beyond mediocrity, an impediment in her speech, which was, however, supposed to be cured, being certainly a bar to her progress. But before she left Covent Garden, in 1789, she had found her true vocation — literature, and to it she devoted herself till her powers began to fail. Her earliest efforts were plays, her first being *The Mogul Tale*, a farce produced in July 1784. She wrote or adapted nineteen plays, her best being the comedies of *Such Things are* (1787), *The Maligned Hour* (1787), and *The Wedding Day* (1794); the farces of *Appearance is Against Them* (1785) and *The Widow's Vow* (1786); and her adaptation from Kotzebue, *Lovers' Vows* (1798). She edited the well-known *Inchbald's British Theatre* (25 vols.), a *Modern Theatre* (10 vols.), and a *Collection of Farces* (7 vols.). But her fame rests not upon her dramatic work so much as upon her novels, *A Simple Story* (1791) and *Nature and Art* (1796), which rank among English standard novels. Mrs Inchbald, who was a Catholic, became very devout in her later years, and died at Kensington House (then a Catholic establishment), 1st August 1821. Her biography by Boaden (2 vols. 1833) is one of the most embossed and ill-digested even of that writer's productions. She wrote an autobiography, but destroyed the MS. by the advice of her spiritual director. See the Memoir by William Bell Scott prefixed to a new edition of *A Simple Story and Nature and Art* (1880).

Inchcape. See BELL ROCK.

Inchcolm, and Inchkeith. See FORTH.

Incidence. ANGLE OF. See OPTICS.

Incedon. CHARLES BENJAMIN, singer, was born at St Kevern, Cornwall, in 1763, was admitted to the choir of Exeter Cathedral at the age of eight, and served in the navy from 1779 to 1783. His voice was now a fine tenor, and in 1784 he made his first appearance at the Southampton Theatre, as Alphonso in the *Castle of Andalusia*. From 1786 to 1790 he sang in the summer at Vauxhall Gardens, and in the winter at Bath. In September 1790 he appeared at Covent Garden Theatre as Dermot in the *Poor Soldier*; and for twenty-five years thereafter he remained unrivalled

as a ballad singer. In 1817 he visited America. Afterwards he travelled through Britain under the style of the 'Wandering Melodist'; and he died at Worcester, 11th February 1826. Incedon's singing was bold and manly, at times full of feeling; his best ballads were such as 'Black-eyed Susan,' 'The Arethusa,' and 'The Storm,' which he sang dressed as a sailor.

Inclination, or DIP. See MAGNETISM.

Inclined Plane. THE, is reckoned one of the mechanical powers, because, by rolling it up a plane, a man may raise a weight which he could not lift. Let us suppose a plane as in the figure, let its length, AB, its height, BC, and its base, CA, be respectively 13, 5, and 12 feet; and let a rolling load of 780 lb. be placed upon it and sustained in position by a pull or push acting up the plane. We



have now three forces in equilibrium: (1) the weight, W, of the body; (2) the resistance, R, of the plane to bending or breaking; and (3) the pull, P, up the plane. These, W, R, and P, are respectively proportional to the length, AB, the base, CA, and the height, BC; and are thus, in the case supposed, respectively 780, 720, and 300 lb. A force which would, if applied vertically, just lift 300 lb., will thus keep a rolling mass of 780 lb. in position upon a smooth inclined plane, the *gradient* of which is 5 (height) in 13 (sloping length); and a force exceeding this would pull the mass up the slope. In every practical case, however, there is a certain force expended in overcoming Friction (q.v.), even on a dead level; in railway trains this is equivalent to vertically lifting about 50 lb. for every ton of dead weight; and when a train leaves a level run to go up a slope of, say, 1 in 80, the engine has then, for every ton of weight, to do work equivalent to vertically lifting 50 lb. + $\frac{1}{80}$ ton = 78 lb., instead of the former 50. The steeper the gradient, therefore, the heavier the pull; and engineers, in roadmaking, avoid as far as possible making steeper slopes than 1 in 20. The inclined plane presents various modifications, such as knives, chisels, axes, wedges, screws; the last two are generally reckoned as distinct mechanical powers, and will be treated each under its own head.

Inclosures. See COMMONS.

In Cœna Domini. a celebrated papal bull, so called from the ancient day of its annual publication, Holy Thursday. It is not, as other bulls, the work of a single pope, but, with additions and modifications at various times, dates back to the middle ages. Its present form, however, it received from the popes Julius II., Paul III., and finally Urban VIII., in 1627, from which year it continued for a century and a half to be published annually on Holy Thursday. It may be briefly described as a summary of ecclesiastical censures, especially of those with which grievous violation of the faith of the church, or of the rights of the church or of the Roman see, are visited; excommunication being denounced against heresy, schism, sacrilege, usurpation of the rights of the church or of the pope, forcible and unlawful seizure of church property, personal violence against ecclesiastics, &c. The bull also denounces other crimes, as piracy, plunder of shipwrecked goods, and forgery. This bull, being regarded by most of the crowned heads of Europe as an infringement of their rights, encountered in the 17th century the determined

opposition of nearly all the courts, even the most Catholic; and at length, in 1770, Clement XIV. discontinued its publication, which has never since been renewed.

Incombustible Fabrics. See FIRE.

Income-tax, a tax directly levied on all persons having incomes above a certain amount. We hear of a tax imposed on property and *incomes* by the English parliament in 1642 during the great Civil War. It became an important feature in the fiscal system during the French war in 1798. It was revived by Sir Robert Peel in 1842, and may now be regarded as permanent. Since 1898 all incomes in Britain under £160 are exempted; deductions are made from incomes between £160 and £400 of £160, between £400 and £500 of £150, between £500 and £600 of £120, and between £600 and £700 of £70. See GREAT BRITAIN, Vol. V, p. 376.

With reference to the equity and reasonableness of the income-tax opinion is divided. The tax is graduated so far; considerations of equity are satisfied by exempting from it an income sufficient for a decent and comfortable maintenance. On the other hand the tax certainly bears an inquisitorial character through the officials of government making investigation into the private affairs of the citizens. Further, as the estimate of income must to a large extent be left to the discretion of the persons taxed, it offers very considerable opportunity for concealment and falsification in the returns; while the conscientious render an account in full, the less scrupulous may pay less than they ought. Also, it is not equitable that incomes gained from hard industrial or professional labour should be taxed as heavily as incomes derived from inherited property. Such considerations have long and vigorously been urged against the income-tax, and it must be admitted that there is much force in them; but there is little prospect of argument taking effect in the abolition of the tax. An increase of income-tax is the great resort of government in times of emergency, particularly during war, or when the fear of war makes special armaments necessary. In 1890 Mr Goschen estimated that every penny added to the tax meant an addition of about £2,200,000 to the revenue (as compared with £800,000 in 1844 under Peel). It is all the more convenient and even indispensable, because taxation in Great Britain is now limited to a very few articles of daily consumption, so that the exchequer has otherwise only narrow scope for increasing the revenue. And, apart from the difficulties of levying it, it must be maintained that the principle of taxing the citizens according to their income, after deducting the minimum necessary for a comfortable living, is perfectly equitable and reasonable.

In the United States an income-tax was imposed in the years 1863-71. It was exempted at first on \$600, then on \$1000, and ultimately on \$2000. Incomes up to \$5000 paid 5 per cent., those between \$5000 and \$10,000, 7 per cent., and all above \$10,000, 10 per cent. An income-tax of 2 per cent. on all incomes over \$4000, enacted in 1894, was declared unconstitutional by the Supreme Court in 1895, as being a direct tax.

Incommensurable. See COMMENSURABLE.

Increment. UNEARNED, is the increase in the rent of land due to the growth of industrial undertakings and of towns, and the general progress of society. Because obtained without exertion or the expenditure of capital on the part of the owners of the land, some economists maintain that it should be specially taxed.

Incubation. THE PERIOD OF, during which birds sit on their eggs before the young are hatched varies in different species, but is nearly constant in

each. In the humming-birds it is only 12 days; in canaries it is from 15 to 18 days; in the raven and in the common fowl it is 21 days; in the duck it is from 28 to 30 days; in the pheasant and in the guinea-fowl it is 28 or 29 days; in the turkey, 30 days; and in the swan, from 40 to 45 days. The degree of heat (about 40° C., 104° F.) necessary for the development of the young is usually supplied by the mother-bird; but in some cases the sunshine (as in ostriches during the day), or the warmth of a nest of decaying plants (as in the Megapodes), is relied upon; nor must it be forgotten that in many Passerine and Running Birds the males take their share, or it may be the entire responsibility of incubation. While the patience of incubation is most emphasised and rewarded among birds, hints of it appear in reptiles—witness the female python; and analogous processes are seen in a few amphibious fishes, and even Invertebrates.

Incubators, or devices for artificial hatching, are used both for practical and scientific purposes at the poultry farm and in the embryological laboratory. From time immemorial the Egyptians have hatched eggs by artificial warmth in peebiar but comparatively simple ovens, and thirty millions of chickens per annum are said to be thus hatched in Egypt. In 1777 Bonnemain devised a hatching apparatus which supplied the Parisian markets with poultry. In 1825 D'Arceet obtained chickens from artificial incubation by means of the thermal waters at Vichy. The *Écocalcibion*, invented by Mr Bucknell, was said to possess a perfect control over temperature from 300° F. to that of cold water for any length of time. The modern incubator consists essentially of a large water-bath and a gas regulator for automatically preventing the rise of temperature above 40° C. The eggs are placed in a tray or drawer, so arranged that the products of the gas combustion are kept away from the eggs, but a supply of fresh air and moisture secured. For embryological purposes the form most used in Great Britain is probably that of the Cambridge Scientific Instrument Company. See OSTRICH-FARMING, POULTRY; also PISCICULTURE.

Incubus. See DEMONOLOGY.

Incumbent, the rector, parson, or vicar holding an ecclesiastical benefice in England. It is the common title in Scotland of episcopal clergymen holding charges.

Incumbered Estates. See ENCUMBERED.

Incunabula. See BIBLIOGRAPHY, Vol. II, p. 132.

Indecent Exposure is a criminal offence both at common law and in England and Ireland also by statute. It is not clearly settled whether more than one person must have witnessed the indecency in order to make it an offence. The exposure must be in some public place, i.e. in a place which may be seen by some considerable number of persons. The offence is punishable summarily by three months' imprisonment. In Scotland indecent practices are also indictable offences, but the law in this respect is somewhat vague, and the punishment is left to the discretion of the court.

Indemnity, an instrument or contract whereby a person is protected against loss, or against the risk of legal proceedings. Fire insurance, for example, is a contract of indemnity; not so life insurance, which is a contract, not to make good an uncertain loss, but to pay a certain reversionary sum. Acts of indemnity are sometimes passed by parliament for the protection of public officers; thus, in 1801 and in 1817 acts were passed to protect officers who had taken part in the apprehension, &c. of persons suspected of treason. From

the year 1727 onward general acts of indemnity were passed from time to time for the benefit of those who omitted to take the oaths of office required by the acts imposing disabilities on dissenters. For the great French war indemnity, see FRANCE, Vol. IV, p. 783.

Indenture, the technical name given in England to a deed under seal, entered into between two or more parties with mutual covenants. Formerly the papers or pieces of parchment on which the duplicate copies of the indenture were executed required to be actually indented—i.e. notched or toothed (Lat. *dent*, 'tooth'), or cut in a wavy line, so as to correspond with each other, but this is no longer necessary. The name is not used in a general sense in Scotland, except in the case of indentures of Apprenticeship (q.v.).

Independence Day, in the United States, falls on the 4th of July, and is observed as a legal holiday. Public meetings are held, orations are delivered, and the general patriotism finds vent in processions and in salvos of artillery, the explosion of crackers, and in displays of fireworks. In the large cities accidents have been not infrequent, and the reckless discharge of firearms is now kept in check. On July 4, 1776, the Declaration of Independence was reported to the continental congress by the chairman; it was read and proclaimed at the state-house on July 8; but it was not signed by all the delegates until August 2, some of them having to wait for instructions from their respective colonies.

Independents, or CONGREGATIONALISTS. The distinctive principle of the Congregational church polity is that every Christian church or congregation is entitled 'to elect its own officers, to manage all its own affairs, and to stand independent of, and irresponsible to all authority, saving that only of the Supreme and Divine Head of the Church, the Lord Jesus Christ.' They regard the Sacred Scriptures as their only standard, and hold that human traditions, fathers and councils, canons and creeds possess no authority over the faith and practice of Christians. Congregationalism denies that there is any authority in Scripture for uniting the churches of a nation or province into one church or corporation to be ruled by a bishop or bishops, superior to the bishops or pastors of particular congregations, or by a presbytery or synod consisting of the pastors or elders of the several congregations of the nation or province. This is the speciality which distinguishes Independency or Congregationalism from Episcopacy and from Presbytery. The term 'Independent' is supposed to have originated in the incidental use of the word in an 'apology' addressed in Latin and English to the British and Continental universities about the year 1604. But the early maintainers of this form of church government were careful to repudiate certain inferences which might be drawn from the use of the word. 'We do profess dependence,' said one of them, 'upon magistrates for civil government and protection; dependence upon Christ and his word for the sovereign government and rule of our administrations; dependence upon the counsel of other churches and synods when our own variance or ignorance may stand in need of such help from them.' The independence claimed was only the right of every individual church to administer its own affairs, free from the control or authoritative jurisdiction of other churches—a right compatible, it was asserted, and is still asserted, with union for the promotion of common ends, and with fraternal aid and counsel in cases of variance or other difficulty. As compared with other societies of Christians who claim spiritual and ecclesiastical independence, this body of Christians may be

defined briefly as independent congregationally, or as 'Congregational Independents.'

Doctrinally the early Independents occupied the same position as the other sections of the Puritan family. They held in substance the evangelical doctrines of the Reformers, of the Westminster Assembly, and of the Thirty-nine Articles.

Not refusing to confess their faith with the other members of the Westminster Assembly, the representatives of the Independents disputed the right of that or any other assembly to confess its faith for posterity, or make that confession binding upon them. Largely Augustinian and Calvinistic in their interpretation of Scripture, Congregationalists have in these later years become more alive to the freedom which their principles involve to interpret Scripture, not according to any one scheme or system, but as loyalty to the light of truth and the spirit of Christianity may dictate. In the reaction which followed the rise of Socialism many Independent societies fettered the use of their property by the insertion of unathletic doctrinal restrictions in their deeds. In later years the use of their property and buildings has been limited only to the catholic interpretation of the teaching of Christ, and what they regard as the New Testament constitution of the religious society.

For the history of this body we must refer to the works named at the end of this article. But it may be mentioned that as early as the days of Queen Elizabeth it was numerous and influential. In a speech made by Sir Walter Raleigh in the House of Commons in 1592, on the subject of a law to transport the Brownists—as they were offensively and untruly named after Robert Browne (q.v.)—he thus refers to their numbers: 'If two or three thousand Brownists meet at the seaside, at whose charge shall they be transported? or whither will you send them? I am sorry for it, but I am afraid there is near twenty thousand of them in England; and when they are gone, who shall maintain their wives and children?' Several eminent men of this body suffered death for their opinions; others were condemned to banishment. The greater part retired to Holland. Numbers sought an asylum in New England; and America still cherishes the memory of the Pilgrim Fathers, as the founders of those institutions which are the sources of her freedom, her intellectual and moral power, and her national elevation.

By the passing of the Act of Uniformity in 1662 the Independents, along with other Nonconformists, were subjected to much suffering. The act required an express assent and consent to everything contained in the revised Prayer-book, and its effect was to cause 1900 or 2000 of the clergy to leave the church. Still the Independents increased; and the Revolution of 1688, and the passing of the Toleration Act in 1689, at length brought them relief. Efforts were made about this time to bring about an accommodation between them and the English Presbyterians; and in 1691 heads of agreement were drawn up, but with little practical result. In 1730 Presbyterians, Baptists, and Independents formed themselves into a united body, under the name of the Three Denominations, for the protection of their civil and religious liberties. The Independents are the largest dissenting body in England except the Wesleyan Methodists. The largest confederation of its churches is 'the Congregational Union of England and Wales,' which is careful to lay down in its basis the principle that 'it shall not, in any case, assume legislative authority, or become a court of appeal.'

An Independent church is, from its very constitution, at liberty to choose any man for its minister whom it considers qualified for the office

—subject only to the check arising from the fact that neighbouring ministers will refuse to ordain or recognise a man whom they have reason to regard as disqualified. But from the beginning the Independents have attached great importance to an educated ministry. Their leaders in the Puritan age, such as Owen, Howe, and Greenhill, were men of great learning, and, as soon as the Act of Toleration in 1689 allowed, measures were taken for securing a succession of educated men.

In 1890 the *Congregational Year-book* reported 4817 churches and preaching stations in the United Kingdom connected with the body, of which 101 were in Scotland, 29 in Ireland, with 91 stations, and in the Channel Islands 11. In Canada there are 184 churches and stations, in Australia 300, in New Zealand 25, in South Africa 41, in Jamaica 41, in British Guiana 38, in India 31, in China 2, on the continent of Europe 4—making a total of 666. There are in all 18 colleges for training ministers, with 62 professors and 472 students; besides the missionary institutes of the London Missionary Society. In 1895 there were 4850 Congregationalist churches in these islands. Their colleges are 'New College,' London, a union of three older colleges—Homerton, Highbury, and Coward—to be ultimately transferred to Cambridge. Cavendish College there having been bought in 1893; Hackney College; Lancashire College, Manchester; Yorkshire College, Bradford—a union of Airedale and Rotherham colleges effected in 1888; Mansfield College, Oxford, formed by the transference in 1886 of Springhill College and its revenues from Birmingham to Oxford, where graduates of any British university are eligible as students, pursuing part of their studies in the theological classes provided by other colleges of the university; Cheshnut College, belonging to Lady Huntingdon's trustees, founded for the preparation of young men for the Christian ministry in any section of the church to which they might be called, but virtually an Independent college; Western College, Plymouth, the oldest of the colleges, dating from 1750; Nottingham and Bristol Institutes for the training of evangelists and village pastors; in Wales, Brecon, Bala, and Bangor; 'Carmarthen Presbyterian College,' governed by Dr Williams' trustees, who are Unitarians, with an Independent theological professor and many Independent students; and the Theological Hall of the Scottish Congregational churches in Edinburgh.

In Scotland Independency may be traced back to the days of the Commonwealth, during which it was imported by the chaplains and soldiers of Cromwell. But the present Independent churches in Scotland owe their origin mainly to a missionary movement in the end of the 18th century, chief among the leaders of which were the brothers Robert and James Haldane, Greville Ewing, John Campbell, and John Aikman. The Haldanes became Baptists in course of time—a circumstance which greatly divided and weakened the new community. The formation of an academy for the training of ministers in 1811, and of the Congregational Union about the same time, did much to restore the lost vigour of the body. It should be added that the Baptist churches, both in England and Scotland, are as strictly 'Independent' as those which bear that name.

In America the first Independent church was founded at Plymouth, New England, in 1620 by a party of pilgrims sent from Holland by John Robinson. In 1637 the spread of Antinomian doctrine caused much discussion in the church. By a synod convened in New England Antinomianism (q.v.) was unanimously condemned. In 1638 Harvard College was founded. In 1658 the Savoy Confession was adopted. It still remains

in force. Unitarian principles spread about 1750 widely in the Congregational churches of America. In 1785 a separation took place between the Unitarians and the Trinitarians, but both still retain the Congregational form of church government. In 1883 the Unitarian churches of this order numbered 360. There is a Unitarian theological seminary at Meadville, Pennsylvania, and Harvard (q.v.) has only of late years been professedly non-sectarian. 'Congregationalism,' according to Dr Schaff, 'is the ruling sect of the six north-eastern states, and has exerted, and still exerts, a beneficial influence upon the religious, social, and political life of the whole nation.' American Congregationalism is somewhat nearer to Presbyterianism than the English type. In addition to the Conference, or Association of Churches, by which they co-operate for common ends, a national council meets triennially 'for advisory and not juridical ends,' but this council is the recognised agency for deciding as to ministerial or ecclesiastical fellowship. In 1895 the number of Congregational churches in the United States was about 4800, with 515,000 church members, and nearly 600,000 children in Sunday-schools. Besides such well-known colleges as Bowdoin, Amherst, Williams, and Oberlin, the American Independents possess theological seminaries at Andover, Bangor, New Haven, Hartford, Oakland, Chicago, and elsewhere.

See Vaughan's *History of English Nonconformity*; J. Fletcher's *History of Independency*; Waddington's *Congregational History, 1200 to 1850*; Hanbury's *Memorials*; Neal's *History of the Puritans*; Dr Stoughton's *Ecclesiastical History of England*; Skeat's *History of the Free Churches of England*; and Barclay's *Inner Life of the Religious Societies of the Commonwealth*. For the scriptural and apostolic basis of the system, Independents refer to Whately's *Kingdom of Christ* and Hatch's *Bampton Lectures* (1880). See also the article PURITANS.

Index (in full, INDEX LIBRORUM PROHIBITORUM or EXPURGANDORUM), a catalogue published by papal authority in the Roman Catholic Church of books the reading of which is prohibited to members of that church, whether on doctrinal, moral, or religious grounds. As a natural consequence of the claim of the Catholic Church to authority in matters of religion, and to infallibility, that church also claims the right or the duty of watching over the faith of its members, and of guarding it against every danger of corruption, the chief among which is held to be the circulation of books believed to be injurious to faith or to morality. The earliest recorded exercise of this restrictive authority is the prohibition of the writings of Arius. The earliest example of a prohibitory catalogue is found in the decree of a council held at Rome (491) under Pope Gelasius, which, having enumerated the canonical books of Scripture and other approved works, recites also the apocryphal books, together with a long list of heretical authors, whose writings it prohibits. The medieval popes and councils pursued the same course as to the heterodox or dangerous writings of their respective periods; and the multiplication of such books after the invention of printing led to a more stringent as well as more systematic procedure. The university press of Louvain issued in 1546, and again in 1550, a catalogue of prohibited books. Similar lists appeared by authority at Venice, Paris, and Cologne; and Pius IV. issued in 1557 and 1559 what may be regarded as properly the first Roman Index. One of the gravest undertakings of the Council of Trent was a more complete and authoritative enumeration of all those books the use of which it was expedient to prohibit to the faithful. A committee was appointed for

the purpose. But it was found impossible to bring the examination of the books to an end before the close of the council; and the entire papers of the committee were handed over by the council to the pope, with instructions that the work should be completed, and the result published by his own authority, which was accordingly done by Pius IV. in 1564. Further additions and certain modifications of its rules were made by Sixtus V. and Clement VII. It was republished in 1595, and, with the addition of such books as from time to time it was deemed expedient to prohibit, in several subsequent editions, the most remarkable of which are those of Brasichelli (Rome, 1607); Quiroga (Salamanca, 1601); and Sotomayor, *Noctissimus Index* (Madrid, 1648). The edition best known to modern theological readers is that of Rome (1819).

The prohibitions of the Roman Index are of two classes, either absolute and total or partial and provisional, until the book shall have been corrected. The ground of the prohibition may be either the authorship of the work, or its subject, or both together. Under the first head are prohibited all the writings of *heresiarchs*—i.e. the first founders of heresies—no matter what may be the subject. Under the second head are prohibited all books confessedly immoral, and all books on magic, necromancy, &c. Under the third are prohibited all books of heretical authorship treating on doctrinal subjects; all versions of the Bible by heretical authors; and all books, no matter by whom written, which contain statements, doctrines, or insinuations prejudicial to the Catholic religion. The preparation of the Index, in the first instance, was committed to the care of the Congregation of the Inquisition in Rome; but a special Congregation of the Index was established by Pius V., and more fully organised by Sixtus V. This congregation consists of a prefect (who is always a cardinal), of cardinals, of consultants, and of examiners of books (*quidificatores*). Its proceedings are governed by rules which have been authoritatively laid down by several popes, especially by Benedict XIV., in a constitution issued July 10, 1753. The growth of modern literature has, of course, entirely outstripped the limited and tardy machinery of this tribunal. A very small proportion even of the most anti-Catholic publications outside of Italy appear even by name in the Roman Index; but, besides the positive prohibitions of the Index itself, there are certain general rules regarding the use of books by which the freedom of what is considered perilous or pernicious reading is much limited among members of the Roman Catholic Church.

In this list—so objectionable to Protestants as striking at liberty of private judgment, may be found the works of Jewel, Usher, Sanderson, Bull, and Pearson, but not the most really formidable English attacks on Romanism, the works of Chillingworth and Hooker, not to speak of Milton, Bunyan, and Swift. Other English works condemned are Chaucer, Spenser, Addison, Goldsmith, and Macaulay. The Index is revised and extended from time to time—as in 1888; and single articles in magazines may be specially censured—as the articles by Mr St George Mivart, a Catholic, on 'Happiness in Hell' in the *Nineteenth Century* for 1892.

Indexing. The need of indexing has become more urgent as the mass of materials to be indexed has increased, and the circle of those who wish to use these materials has become wider. Lord Campbell proposed to bring a bill into parliament to deprive an author who published a book without an index of the privilege of copyright. There are two classes of books to be indexed—viz. books of facts and books of opinion. In the indexing of the first class, experience, care, and common sense are needed, and the work must be systematic and not casual. In the second class these qualifications are required and something else—viz. the insight of the

precis writer. The indexer must understand his subject and also understand the wants of the reader. The index must be exhaustive in its indication of the various points in the book, and concise in expression, and in addition the indexer must be careful in the choice of catchwords or titles for his headings. He must gather together the same subjects under one heading, and see that they are not separated under synonyms. An author frequently uses periphrases to escape from the repetition of the same fact in the same form; but these periphrases will give little information when inserted as headings in an index, and it is in this power of selecting the best catchword that the good indexer will show his superiority over the commonplace worker. The meaning of the word index has gradually grown from the general to the particular, and the word is now established as denoting a series of references arranged in alphabetical order. There are other kinds of indexes; but these require an explanatory adjective, as classified, chronological, &c. In indexing names it is most important to specify the cause of reference, as a block list of references after a name is almost useless. A colossal instance of this fault will be found in Ayseongh's index to the *Gentleman's Magazine*, where all the references under one surname are placed together without even the distinction of the Christian name. There are 2411 entries under Smith, and it has been calculated that to go through this mass in order to find say Zachary Smith would take the consulter eight days of ten hours a day. It is also important to bring all the references to one man under one heading, and not to separate them under the different names or titles he may have borne. In the index to Scott's edition of Swift's Works there are 638 references to Harley, Earl of Oxford, arranged thus: 227 under Robert Harley, 111 under Lord Oxford, and 300 under Treasurer (Lord Oxford). There should be one index for a complete work and not a separate index for each volume. Again, no classification should be allowed in an alphabetical index. This vicious habit of classification makes the indexes of some well-known papers practically valueless. The consulter of the index wishes to find whether the volume contains anything on a particular subject, and he is only confused and annoyed if he has to look in a succession of alphabets arranged under such headings as original articles, notes, correspondence, &c. The preparation of an index consists of three divisions: (1) compilation, (2) arrangement, (3) printing. Each indexer will find out the mode of procedure which is most suitable for himself; but it may be said generally that foolscap paper is the most convenient size for use. Those entries which are not likely to be repeated can be written down on the page as they occur; but in the case of large headings it will be more convenient to use a separate page for each, and keep these pages in an alphabetised guard book so that they can be turned to in a moment. When the time comes to cut up the index and arrange it in alphabetical order, it will be necessary to see that there are no repetitions of the same subjects under various synonyms. Now is the time to make the cross references, and here considerable judgment is required. When the entries are short and few, it is better to repeat them than to refer from one to the other; but in the case of long entries cross references are very advantageous, and it is always well to refer to cognate headings. No reference to the contents of a general heading which is without subdivision should be allowed. If a general heading is divided into sections, and each of them is clearly defined, they should be 'cross referenced,' but not otherwise. When the arrangement of the cut up slips is undertaken some alterations and revision

of headings will frequently be found advisable. The value of an index is greatly enhanced by the proper setting out of the entries with judicious use of different types. When a book is a complete treatise on a special subject, a well-made index will form an admirable key to the subject and be in itself intrinsically useful. Indexes may also be made with regard to a particular subject dealt with in a number of books.

The Index Society, to form a library of indexes, and to make indexes to important books, rare serials, &c. was founded in 1877, and subsequently incorporated with the British Records Society; their publications appear quarterly in the Index Library. The American Library Association Index (1893) indexed 3000 miscellaneous volumes. See books mentioned in the article BIBLIOGRAPHY, and H. B. Wheatley's *How to Catalogue a Library* (1890).

India, an extensive region of southern Asia, and next after China the most populous area in the world. It was celebrated during many ages for its riches and natural productions, its beautiful manufactures and costly merchandise, the magnificence of its sovereigns, and the early civilisation of its people. It possesses especial interest to British people from the imperial connection of its history with that of their own nation. It affords, too, the greatest market in the world for British textile manufactures, and a great field for the employment of British capital.

Nomenclature.—The name India comes to us, through the Romans, from the Greeks, who borrowed it from the Persians. The latter applied the name Hind to the dwellers in the basin of the Sindhu River, a Sanskrit name for the Indus. Sindhu, by the regular change of *s* into *h*, becomes Hind. The river is still called Sind; while the land is Hind. Officially, then, the country is Hind in the vernacular, and India in English. The national name Hindu is derived from Hind. Then from Hindu came the name Hindustan, which is only a province—viz. the region of the Jumna and the Ganges. This name has sometimes been applied to India as a whole, but this is quite erroneous.

Geographers write of Further India and Hither India. The former, lying eastward beyond the Malay Peninsula, is mostly in native hands, and partly under French protection. The latter is under British dominion, and is in legal phrase India. It was in 1877 proclaimed as the Indian empire. This article will refer only to the official India thus indicated. It will for method and condensation be divided into five parts—I. The Land; II. The People; III. The Government and the Military Defence; IV. The Civil Administration; V. The History.

I. THE LAND.

India is the central peninsula of southern Asia, and lies in 8° 4'—35° N. lat. and 67°—92° E. long. According to these limits, its length may be stated approximately at 1900 miles, and its breadth, reckoned along the parallel of 25° N. lat., at 1600 miles, with an area of at least 1,350,000 sq. m. But in round numbers the square miles contained in this area may be reckoned at one million and a half—inclusive of Burma. The natural boundaries of this vast region are, on the N., the range of the Himalaya Mountains, which separates it from Tartary, China, and Tibet; on the W. the Suliman Mountains, dividing it from Afghanistan and Beluchistan; on the SW. and S. the Arabian Sea and the Indian Ocean; on the E. the hill-ranges which border upon Burma, and the Bay of Bengal. From the mouths of the Brahmaputra on the eastern side, and of the Indus on the western side, the two coasts, east and west, incline towards the

same point, and meet at Cape Comorin, thus producing the form of an inverted triangle. The two sides of the triangle have together a coast-line of about 2000 miles. Thus southern and central, or as it may be called peninsular India, is from its extent of seaboard a maritime country. It is northern India only that has a continental character.

Geography.—For the geography of India there exist excellent materials from the *Grand Trigonometrical Survey*—a work of the highest scientific value—which has determined the height of the mountains and the situation of all the principal places; from the topographical survey, which has displayed the contour and configuration of the whole country; from the revenue and cadastral surveys, which have delineated the boundaries not only of villages but of fields also for all provinces except Bengal and Behar. The region presents a diversified surface and scenery. It has indeed been called 'an epitome of the whole earth,' consisting as it does of mountains far above the level of perpetual snow, broad and fertile plains, bathed in intense sunshine, arid wastes, and impenetrable forests. Its natural divisions are the Himalaya, the sub-Himalayan ranges, the plains of the Ganges and the Brahmaputra, the basin of the Indus, the highlands of Hindustan, the Vindhya and Satpura ranges, and the peninsula south of those ranges.

The Himalaya (meaning 'the abode of snow') consists of a chain some 1500 miles in length, in which the links are formed by mountain knots covered with perpetual snow, some of which rise from 20,000 to near 30,000 feet above sea-level, and are the highest yet discovered in the world. It is the dominating factor in the geography of northern India, being the source of the Indus, the Ganges, the Brahmaputra, and of their principal affluents. See HIMALAYA.

The sub-Himalayan ranges run between the chain of the Himalaya and the plains of the Ganges and Indus. They occupy Cashmere, the Simla hill-states, Gurhwal, Kumaon, Nepal, Sikkim, and Bhutan, which, owing to their elevation above the sea (5000 to 9000 feet), have a climate like central Europe in summer and cold as Switzerland in winter, with the vegetation of the temperate zones. These regions are separated from the plain of the Ganges by the submontane tract called Terai, which extends in a long belt, 5 to 25 miles in width, from Hurdwar (where the Ganges issues from the sub-Himalayan ranges) to the Brahmaputra. It is covered with forest, and is the haunt of wild beasts. The soil is very fertile, but malaria has rendered it uninhabitable by man and the domestic animals, at least from April to October. This wilderness is being gradually narrowed or invaded by the progress of drainage and cultivation.

The plains of the Ganges and the Brahmaputra, which include Bengal, Behar, the Doab (meaning the 'Mesopotamia' of the Ganges and Jumna rivers), Oudh, and Rohilkund, form an alluvial flat, terminating in a delta, and extending from the Bay of Bengal to the slight uplands on the Punjab border that form the water-parting between the Ganges and the Indus. Throughout its entire length the Ganges and its numerous tributaries spread out like the veins of a leaf, carrying everywhere their fertilising influence. The population of these fertile and well-cultivated plains is very dense.

The basin of the Indus, in the north-west, is towards the south separated from that of the Ganges by the Aravalli Hills. The Punjab occupies the northern portion. South of the Punjab, and parallel with the river, the great sandy desert of the Indus extends for nearly 500 miles. The valley of the Indus is continued through Sind to the

20 25 30 35 40 45 50 55 60 65 70 75 80 85 90

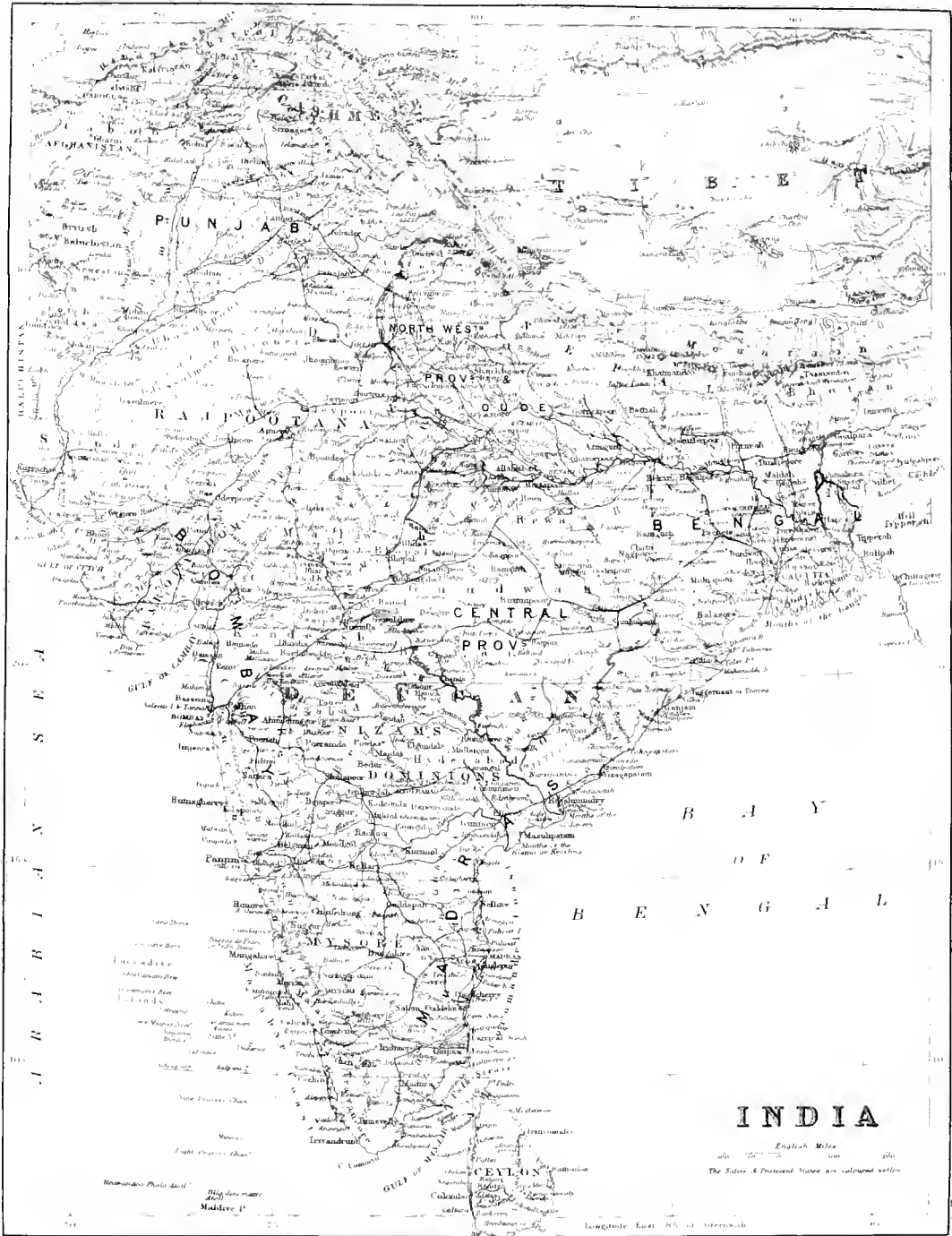

INDIA

English Miles
 The States & Provincial States are coloured red

Longitude East 85° of Greenwich

Arabian Sea. Between the Indus region and the Aravalli Hills lies the Thar desert, an expanse covered with sandhills, 400 miles long and 100 broad. It is only in the neighbourhood of the Indus and some of its tributaries that the surface can be cultivated by means of river-irrigation—although crops of grain may be grown in hollows and narrow valleys after the rains. The horse and camel alone can cross this desert, which is described in Hindu geography as 'the region of death.'

The highlands of Hindustan extend from the Vindhya and Satpura mountains as a base to the border of the Thar desert. They include the tableland of Malwa and Rajputana or Rajasthan, which has an elevation of about 2000 feet above the level of the sea.

The Vindhya and Satpura ranges are two hill-chains, with an elevation from 2500 to 4000 feet, partly though not entirely parallel from east to west, and divided from each other by the valley of the Nerbudda River. They form what may be called the backbone of middle India, or, by another metaphor, a broad wall dividing northern from southern India.

The peninsula south of the Satpura range is in two divisions. The first is the Deccan (q.v.), which name means 'the south.' This area is a central tableland extending from 12° to 21° N. lat., rising from 1500 to 2000 feet above the sea, and enclosed on all sides by mountain-ranges. These ranges are the Satpuras above mentioned, the Eastern Ghâts, somewhat low, facing the Bay of Bengal, and the Western Ghâts, higher and more important, facing the Indian Ocean. Between the Eastern Ghâts and the sea are fertile littoral tracts known to history as the Northern Circars and the Carnatic. Between the Western Ghâts and sea is a similar tract known geographically as the Konkan. As a northern continuation of this tract is Gujarat, with its offshoots the peninsulas of Kathiawar and Cutch. From the low land of the Konkan to the Deccan plateau the mountains rise in a succession of geological formations looking like gigantic terraces. The rivers of the Deccan rise in the Western Ghâts, and, after traversing the tableland, descend to the sea by passages through the Eastern Ghâts. The slope of the country corresponds with the course of the rivers; it has a gradual inclination towards the east. The second division begins technically from the Tungabhadra River, but geographically from the hills south of Cuddapah. It extends right down to Cape Comorin, the apex of the inverted triangle, and includes Madras, Tanjore, Trichinopoly, Tinnevely, and other famous places.

To this summary of natural divisions a brief notice of the mountains and rivers may be added.

The *mountain-system* forms a connected whole. It is separate from the Himalaya and from the Suliman range, which forms a wall between India and Afghanistan. It may best be followed from the southern point, Cape Comorin, northwards, thus: From that point there run upwards two long lines of hills and mountains, one north-easterly, the other north-westerly. The north-easterly line comprises the Eastern Ghâts already mentioned, which become merged in the hilly region on the west of Bengal, and runs up to the neighbourhood of Allahabad, at the junction of the Jumna and the Ganges. This line nowhere exceeds an altitude of 3500 feet above sea-level. The north-westerly line comprises the Travancore and Palni hills, the Nilgiri, the Western Ghâts, the Aravallis, and the Rajasthan hills, up to the neighbourhood of Delhi. This line has at several places considerable altitude, for example in the Nilgiri ('Blue Peak'), 8000 feet and upward; and Mahabaleswar (near Poona) and Abu in Rajputana, upwards of 4000 feet. These

two lines are as the sides of a triangle, and are joined at the top by the two transverse and parallel ranges of the Vindhya and Satpura already mentioned. Thus the mountain-system, like the external configuration of the country, is in the shape of an inverted triangle.

The *river-system* may be thus epitomised. The Indus in the north-west, with a course of 900 miles after issuing from the Himalayas, drains with its four famous affluents, the Sutlej, the Ravi, the Chenab, and the Jhelum, about 300,000 sq. m., and empties itself into the Arabian Sea. In the north-east the Ganges, with the Jumna and other affluents, and the Brahmaputra and Meghna—all which join in the Bengal delta—drain about 500,000 sq. m. Owing to their virtual amalgamation in Bengal, it is difficult to assign a length to the courses of these rivers, which empty themselves in the Bay of Bengal. The central region—viz. that of the Vindhyas and the Satpura—about 100,000 sq. m.—is drained by the Nerbudda and the Tapti, the former having a course of 800 miles, the latter of 400 miles, and both flowing west into the Gulf of Cambay, a branch of the Arabian Sea. The remaining area (viz. 600,000 sq. m., out of a total of 1,500,000) consists of the Deccan and the peninsula. It is drained by the following rivers: Mahanadi, with a course of 520 miles; Godavari, 898; Krishna, 800; Tungabhadra, 400; Pennar, 350; and Kaveri, 470. There are many other rivers which cannot be particularised here. Among them may be mentioned the Hooghly and the Gumbi, Calcutta being situated on the former and Lucknow on the latter; both belong to the Gangetic system.

Geology.—In 1856 a staff of geologists commenced a geological survey of India, which has since then been steadily continued. They have examined an area several times as large as that of Great Britain, and supplied for the districts with which they have dealt an accurate knowledge of the mineral resources.

Professor Medlicott summarises the general result thus. 'Geologically India is divided into three distinct areas: (1) peninsular and (2) extrapeninsular, separated by (3) the Indo-Gangetic plains, formed of the deposits of those great rivers and their tributaries. (1) is a land surface of immense antiquity, all the fossiliferous rocks within it being of aerial or fluvialite formation, and the newest of them of Lower Tertiary age. It is principally a *massif* of gneissic rocks, with bands and basins of transition strata of various ages, culminating in the Vindhyan formation, of unaltered and undisturbed strata, yet of undetermined age, being unfossiliferous. Totally separate from the Vindhyan comes the Gondwana formation: near its base the Indian coal-measures on Upper Palaeozoic, while the top group, where near the coasts, contains Upper Jurassic marine fossils. A great volcanic formation, known as the Deccan Trap, covers an immense area in Bombay and Central India; the deposits locally found in it contain only fresh-water fossils; in Gujarat it occurs between Eocene and Cretaceous marine strata. Along the outer margin of the plains (2) presents an almost unbroken face of Tertiary rocks, of immense thickness, and more or less intensely disturbed. On the west, associated with Cretaceous strata, they extend to form the uplands of Afghanistan and Persia. On the east, again associated with Upper Secondary beds, they abut against the crystalline rocks of the Malayan axis. On the north they form the sub-Himalayan chain at the base of the central Asian *massif*, the southern ridges of which form the Himalayas; in this position the Tertiary series, except at its very base, is inclusively of fluvialite formation, like

the plains, and contains the famous Siwalik mammalian fauna. The outer Himalayan is formed of crystalline and other rocks of uncertain age; but on the north side of the range there is a full succession of Palaeozoic and Secondary marine formations. At the north-east angle of the plains the Shillong plateau of crystalline rocks, capped by horizontal Tertiary strata, separating the lower Assam valley from Sylhet in eastern Bengal, is an outlier of the peninsular massif. At the north-west angle of the plains, in the Salt Range of the Punjab, there is again a small exposure of the ancient limit of the peninsular massif, presenting an outcrop of coastal deposits of Palaeozoic age. Besides the Gondwana coal, a light coal occurs sporadically in the Tertiary rocks from Sind to Cashmere, and in upper Assam there are rich coal-measures of about the same age; in both these regions, also, petroleum is more or less abundant. Pure iron ores are abundant throughout the peninsula and in the outer Himalaya; other ores are comparatively scarce, except along the Malayan axis. The diamonds of India and the aluminous gems of Burma are well known.

In ancient times there were gold-mines in the mountains of the south-western regions, which supplied the metal for the gold coinage which was then almost universal in the country. The most accessible parts of the auriferous strata have been worked out ages ago, and the remnant forms what is known as the Mysore mines. There are other auriferous deposits in parts of the Deccan. Silver has never been discovered in any appreciable quantity within the country; but in the middle ages it was introduced largely from across the Himalayas and used for coinage. In the Shan dependencies of Burma, however, it is extracted from lead ore. Coal is obtained largely in western Bengal, in the Satpura Hills to a considerable extent, and in the Deccan to some extent, and in some other places also—enough, on the whole, to supply the railways. Iron and copper are found and worked in many parts of the country. There are many other mineral products of lesser importance. Diamonds are still found in the central hills, and ruby mines are worked near the Irawadi. The mineral resources on the whole are inferior in importance to the agricultural. See the *Manual of the Geology of India*, by Medlicott, Blanford, and Ball (3 vols. 1879-81).

Climate. It follows from the foregoing summary of geography in a country extending over 26° of latitude—one extremity of which runs far into the torrid zone, and the other terminates in a range of mountains rising far above the line of perpetual snow—a country embracing lowland plains, elevated plateaus, and alpine regions, that the climate must be extremely varied. The whole country has three well marked seasons—the cool, the hot, and the rainy. This characteristic applies without distinction to all parts of the country; even to the Himalayas, which have otherwise a climate like that of Switzerland. The cool months are November, December, January, and a part of February; the dry hot weather precedes, and the moist hot weather follows the periodical rains. The rainy season falls in the middle of summer; its beginning is earlier or later according to circumstances, its ending is in September. But in Burma it lasts longer; and in the peninsula there is a second rainy season, called the latter rains, during the autumn. The winter is the pleasant period; the spring is generally hot and healthy; the summer depends on the duration of the rains; the autumn is close, malarious, and unhealthy. The rainy season everywhere comes from the same cause viz. the attraction by the sun of moisture from the ocean in clouds, and their condensation into rain

upon the land. It is called monsoon, probably a corruption of the Persian word for season (see MONSOON). It is the occasional failure of the monsoons that causes the periodical famines to which the country is liable. The central tableland is cool comparatively, but the alternations of heat and cold differ greatly elsewhere. In the north-west there is burning heat with hot winds in summer, and frost at night in winter. In the south the heat is more tempered, but the winter is cool only, and not cold. At Ootacamund, on the Nilgiris, 7200 feet above the level of the sea, the mean annual temperature is 58 F.; at Madras, 83; Bombay, 84; Calcutta, 79; Bangalore, 74; and at Delhi, 72°. But at places like Delhi, where the heat of summer is tremendous, the average is reduced by the cold in winter. The fall of rain varies greatly in different parts of the country. In the north-eastern and other outlying parts it exceeds 75 inches; at one observatory in north-east Bengal, Cherra Punji, there is a phenomenal fall of 600 inches in the year. In the Deccan, in the upper basins of the Ganges and the Indus, it is 30, and in the lower regions of the Indus less than 15 inches. The remainder of India is placed between the extremes represented by these damp and dry belts, but is, as compared with Europe, an arid country. Hence the necessity of tanks and irrigation canals to supply moisture to the soil, and to obviate the danger of drought and famine. A meteorological department has been established, with 161 observatories, the chief of which are at Calcutta and Bombay. See Henry F. Blanford's *Practical Guide to the Climates and Weather of India* (1889).

Fauna.—The domesticated animals are, first, the cattle—cows, buffaloes, oxen; the last two do the work of agriculture. The bull and cow are sacred animals to Hindus, and by them are never killed for food. The indigenous breeds of horses in India are being improved by the importation of foreign sires. They have never been employed in agriculture. The pony, the donkey, and the mule are largely used. Sheep and goats are abundant. The pig is plentiful, but is despised by the upper and middle classes of the people. The monkeys are tame and are held sacred. The wild animals include the tiger, panther, cheetah, boar, bear, bison, elephant, and rhinoceros. The crocodile and alligator infest most of the rivers. Deer of all sorts abound everywhere, and mainly supply sustenance to the carnivorous animals. The lion, the hyena, the lynx, and the wolf are unimportant. The elephant is used only for purposes of war or of state, both by the government and by the native nobility. The ibex and the ovis-ammou (the wild goat and the wild sheep) are found only in the highest parts of the Himalayas. Poisonous snakes abound, the worst being the cobra da capello (the black-hooded); many thousands of the natives die from snake-bite in the year. The government offer rewards, and many thousands of animals, including snakes, are destroyed. The area supporting these animals has shrunk during the present century from the spread of cultivation, and is still shrinking. Destructive visitations of locusts happen occasionally. The birds are, of course, infinitely various; but several of the most beautiful or remarkable species are wanting. The eagle is found only in the Himalayas, so is the pheasant. The partridge is seen in all the plains, and in some places the quail is abundant. The snipe is found in the marshy land; waterfowl swarm in some localities, and flights of wild geese sweep through the air. Vultures and other birds serve as scavengers. The crow is common everywhere, but not the raven.

At the seaport towns the supply of fish for

European consumption is excellent, and fish-curing is largely practised by the natives. Inland the fishing in the mountain-streams is good, but in the rivers of the champaign the fish, though abundant in quantity, are not esteemed for quality. See W. T. Blanford's *Fauna of British India* (1888) et seq.

Flora.—Nearly half of the country is tropical, though none of it is equatorial, and a part is not only temperate, but cold; accordingly the vegetation varies greatly. As compared with equatorial regions, the country has tropical products plentiful and good, but not first-rate, such as tobacco, sugar, ginger, and spices of all sorts. Rice has from time immemorial been a staple. Maize and millet are articles of food for the stronger races. Oilseeds are largely exported. The cultivation of wheat has greatly developed for exportation since the era of cheap prices. Tea is grown largely under European supervision in the Eastern Himalayas, and already surpasses the China teas. Coffee is grown in the south, but with chequered success. Among the dyes, indigo and lac (red) are noteworthy. European flowers of all sorts are cultivated nowadays. The indigenous flowers are not rich, the water-lilies being the best; the flowering shrubs are very fine, however. Of trees in the plains near the coasts the palm order with its several varieties strikes the observer. Inland the mango fruit-tree and the orange, the umbrageous banyan, the sacred peepul, and the bamboo are features in the landscape. In the hills the teak and other useful timber trees are obtained. In the Himalayas are the cedar, the pine, the fir, the juniper.

The primeval forests which covered the country have long been restricted to the hill and mountain system already described. But further, in this country, as in many other countries, the hills have been deforested by reckless destruction during many generations, to the injury of the climate and of that water-supply on which so much depends. Conservation of forests was not attempted under native rule, nor under British rule until the middle of the 19th century. Since that time, however, a forestry department has been set up as a branch of the administration in every province, with European officers trained in Europe. For the whole country, the forests under supervision amount to 100,000 sq. m., of which two-thirds are under complete conservancy. Besides augmenting the national resources, the forestry is profitable, and yields a net revenue yearly of more than half a million sterling.

The agricultural statistics show that barely one-third of the whole country is cultivated or grazed. Of the remainder a portion is available for cultivation; the rest is uncultivable, consisting of still hill-sides, desert, river-beds, &c.

II. THE PEOPLE.

Population.—This has since the middle of the 19th century been ascertained by census. The decennial census of 1881 showed 253 millions of souls for the whole country, including the British territories and the native states, and an increase of 13 millions over the preceding census. This total was exclusive of the population of the Cashmere state, which really belonged to the country, and of Upper Burma, subsequently annexed. With Cashmere and all Burma the population at the census of 1891 was 287,223,241, an apparent increase of 33,429,917 (deducting the areas not reckoned, a net increase of 27,824,420); and this total excludes Nepal, Bhutan, Sikkim, and the French, Portuguese, and Dutch territories. In round numbers, then, the population may be stated at 290 millions. But though populous the country is not as a whole densely peopled; the

average of inhabitants to the square mile being 229 for the British provinces, 111 for the native states, and 184 for the whole country. The hill and mountain system, indeed, shows a sparse population; but the plains of the Ganges and the Brahmaputra, again, and the coast districts and the southern peninsula, are densely peopled. The Gangetic plain generally has an average of 400 to the sq. m.; and some parts of it, near Benares and Patna, show an average actually double the above, and a density which is quite excessive. Of the 287 millions not more than 30 were urban, the rest being rural. Thus the vast majority of the people live in the country, and most of these are agricultural or pastoral. Everywhere the returns show an excess in the number of males over that of females.

The population of the three presidency cities are: Calcutta, 861,764; Bombay, 821,764; Madras, 452,518. Below these there are twenty-five towns with more than 100,000 inhabitants each, and below these again forty-seven with more than 50,000 each.

Ethnology and Language.—The languages of the present day as well as those spoken in former ages, as far as these are known to us, belong to four different stocks—viz. the Aryan, Dravidian, Kolarian, and Tibeto-Burman stocks. In point of chronological order the Kolarians appear to have been the first settlers, and all indications point to their having originally entered India from the north-east, and having thence spread westwards over the northern plains. As regards the tribes speaking Tibeto-Burman dialects, they are confined to the skirts of the Himalayan range; thus forming, as it were, the southern edge of the wide Tibetan speech-field, having probably penetrated at various times, from the plateau of Tibet, through the numerous passes of the Himalayas. Eastwards, again, these dialects stretch, in a more or less continuous chain, until they merge in the compact body of Burman speech. But whilst a separate linguistic development makes it necessary to treat the Kolarian and Tibeto-Burman languages as two distinct groups, it is yet highly probable that they were ultimately derived from the same Mongol stock. After a time the Kolarian settlers would seem to have been disturbed in their possession of the northern plains by the inroads of Dravidian tribes. These, having gained entrance into India through the north-western passes, seem to have pushed forward, driving the Kolarians into the mountainous districts which border the Gangetic plain in the south, and ultimately to have forced their way through them, and poured themselves in a mighty stream into the southern peninsula. Whether in so doing they were already urged onward by tribes of another race following in their wake we do not know; certain it is, however, that at some time or other subsequent to the immigration of the Dravidians—probably more than 4000 years ago—people of the Aryan stock must have entered the 'land of the five rivers' (Punjab) either through those same passes of the Suliman range, the command of which has so often decided the fate of India, or by a more northerly and yet more rugged route, across the Hindu-Kush, and by way of the Pamir plateau and the highland valley of Cashmere. In favour of this latter alternative it has been urged that there are to this day settled, to the north of Cashmere and Kabul, several tribes of the Aryan stock, such as the Dards and the Sial-Posh Kalins, whose vernacular dialects are of so archaic a character as to have suggested the idea that these tribes may perhaps be the direct descendants of some remnants of the primitive (Indo-Iranic) Aryans which had remained behind in the old homes when the great body of their brethren took their departure in quest of more favoured abodes. However, our knowledge

of these waifs and strays of the Aryan stock is still very imperfect; and they may after all turn out to be mere detached dialects of either the Indic or the Iranic branch of Aryan speech. Between these two divisions no sharp line of demarcation can indeed be drawn; but the languages of the countries west of the Indus—viz. the Pushtu (or Pakhtu) of the Afghans, and the Baluchi, one of the two principal languages of Beluchistan—form intermediate links, being by most scholars included in the Iranian group, whilst others would rather refer them to the Indian division.

(1) *Indo-Aryan Group*.—The earliest accessible form of Aryan speech in India is the *Vedic*, especially the language of the sacred hymns of the Rigveda which represent the Aryan tribes as settled in the Punjab. Even at that early period dialectic varieties seem already to have existed to some extent among different tribes. In the course of the later Vedic ages the Aryan language extended its sway eastward over nearly the whole of northern India. During this process foreign ethnic elements were doubtless largely absorbed by the Aryan community, and the greater or less proportion of such admixtures, coupled with independent political formations, could not fail ere long to produce different dialects of marked individuality. Meanwhile, the exegesis of the sacred hymns, already largely unintelligible at the time when they were first collected, and the consequent close cultivation of grammatical and phonetic studies, resulted in the grammatical fixation of the literary language (hence called *Sanskrit*—i.e. 'completely or correctly formed, polished'), probably about the 6th century B.C. Henceforth the divorce between the literary idiom and the popular dialects was complete. The existence of such dialects at that time is amply attested by the fact that Gautama S'akyamuni (or Buddha, 'the awakened,' as he subsequently called himself), in preaching his new gospel of salvation through individual righteousness, made use of the Magadhi, commonly called *Pali*, the local dialect of his native Magadha (Behar), which accordingly became the sacred language of Buddhist literature; but being as such a grammatically fixed idiom, like the Sanskrit, it became gradually estranged from the vernacular with which it had originally been identical. The canonical books of the Buddhists were settled at a council held in the reign of the Emperor As'oka about 250 B.C., but they were not committed to writing till about 80 B.C., so that the state of their language is attested for that period at latest. The same Emperor As'oka has, however, left us authentic dialectic documents of his own time—viz. the famous rock inscriptions, containing religious edicts, and scattered over the area of northern India from the vicinity of Peshawar on the north-west frontier, and Girnar in Gujarat, to Cuttaek on the eastern coast. Similar in its origin to the Pali, another local dialect, the *Maharashtri*, or language of the province of Maharashtra (the present Malhatta country), became the religious dialect of another large sect, the Jains, which seems to go back to about the same time as the origin of Buddhism. Moreover, several popular dialects were early employed for literary purposes by Indian dramatists. While the use of Sanskrit in dramatic literature is confined to male characters of the higher classes, women and inferior male characters are invariably made to speak various local dialects. These dialects, called *Prakrits*—i.e. either 'vulgar' or 'derived (from the Sanskrit)'—may be looked upon as the forerunners of the modern vernaculars of northern India. Though the oldest existing plays can hardly be placed earlier than the 6th century of our era, the actual use of the Prakrits, as popularly spoken

dialects, may go back some centuries before that time. The principal *Neo-Aryan* languages of India are (1) *Bengali*; (2) *Urjju* (of Orissa); (3) *Hindi* (of the Upper Provinces), with the closely allied *Punjabi* and *Nepali* (the language of the Goorkhas, the ruling class of Nepal); (4) *Sindhi* (on the lower Indus); (5) *Kashmiri*; (6) *Marathi*; (7) *Gujarati*—which Beames (*Comparative Grammar of the Modern Aryan Languages of India*), however, takes to be a mere dialect of Hindi. To these may be added (8) *Assamese*, formerly considered a dialect of Bengali; (9) *Brahui*, one of the two languages spoken in Beluchistan, which at one time was thought to be Dravidian, whilst some scholars would even now refer it to the Kolarian group; and (10) *Sinhalese*, the language of the southern half (perhaps at one time of the whole) of the island of Ceylon, doubtless imported from northern India, in the early centuries B.C., by Buddhist immigrants; with its literary dialect called Elu, and the dialect of the Aryanised aboriginal Veddahs.

Many of these languages show a considerable number of dialectic varieties, especially the Hindi, by far the most important of all, of which as many as fifty-nine dialects are enumerated by Curt (*Modern Languages of the East Indies*). Not a few of these dialects are, however, of a very mixed character, owing to their being spoken by Aryanised tribes of one of the three other groups, and consequently showing a more or less strong non-Aryan element. A peculiar and important form (for it can scarcely be called a distinct dialect) of Hindi is *Urdu* or *Hindustani*, which, being Hindi, with a more or less considerable admixture of Persian (and Arabic) words, and written in the Persian character, originated, after the Mohammedan conquest, through the official intercourse of the Persian-speaking rulers and their Hindu subjects—much as in English the original Teutonic groundwork has been overlaid by a thick layer of Romance and Latin vocables and formative elements—and has developed into a kind of *lingua franca* for the whole of India; a southern variety of it being called *Dakhani* or *Dekhani*. In point of the antiquity of its literary documents, Sinhalese stands pre-eminent among Neo-Aryan languages; its development from, or by the side of, Pali being well authenticated by Elu works going back to the 5th century of our era, and by inscriptions of very early date. Next to it comes Hindi, commencing, about 1200 A.D., with the Prithiraj Rasau, a heroic poem by Chand Bardai, composed in an archaic form of Hindi which Trumpp proposes to call 'Old Hindi;' whilst the term 'Hindu' is applied by him to a somewhat more modern form, represented by the writings of the religious reformer Kabir (c. 1450 A.D.), the sacred books of the Sikhs (the Granth), and Talsi Das's translation of the Sanskrit epic Ramayana. In Marathi the oldest existing work, a paraphrase of the Sanskrit philosophical poem Bhagavadgita, claims to have been written in 1290 A.D.; whilst Bengali literature commences with the religious writings of the Vaishnava reformer Chaitanya, a contemporary of Luther. None of the other languages possess any literature above two or three centuries old.

(2) *Dravidian Group*.—The extension of the Brahmanical civilisation and literature has introduced into these languages, as into those of the other stocks, a very considerable element of Sanskritic words; whilst their grammatical structure has, on the whole, remained intact. As regards the ultimate affinities of this stock, Dr Caldwell, in his *Comparative Grammar of the Dravidian Languages*, has shown that Dravidian speech, in its formative features, betrays a 'family likeness' to the Scythic (Finnic-Tataric) stock; whilst he

also detects in it certain analogies, though of a rather indefinite and remote character, to Aryan speech. The people speaking Dravidian languages occupy a compact area extending over the whole of the southern part of the peninsula, with one or two enclaves in the Aryan territory. Dravidian scholars recognise twelve distinct languages, only four of which, also the most important in regard to population, have developed anything worthy of the name of a literature—viz. (1) *Tamil*, occupying the south-eastern; (2) *Telugu*, the north-western; (3) *Kanarese* (or *Kannada*, i.e. Karnataka), the north-eastern; and (4) *Malayalam*, the south-western portion of the Dravidian area. The remaining members of the family are (5) *Tulu*, between the two preceding ones, on the Malabar coast; (6) *Kodagu*, the language of Coorg, adjoining the last named, inland; (7) *Tulu* and (8) *Kota*, both spoken by tribes of the Nilgiri hills; (9) *Gond*, in Central India; (10) *Khond* and (11) *Oráon*, west and north-west of Orissa; and (12) *Rajmahal*, or *Máler*, the language of a tribe of the Rajmahal hills in Bengal. Tamil, which has also extended its sway over the northern half of Ceylon, may boast of a rich and varied literature; its oldest works—the Chintámáni, an epic poem of 15,000 lines, and the Kural, a collection of ethical stanzas, both of them by Jain poets—probably dating back to the 10th century, if not earlier. In the sister languages, Nannaya's Telugu translation of the epic Mahábháráta and Kes'ava's Kanarese grammar probably belong to the 12th century; whilst Malayalam, originally a mere dialect of Tamil, commences with the heroic poem Rámácharita, of uncertain date, but probably a century or two later than those works.

(3) *Kolarian Group*.—The term, derived from the tribal name of the Kols, was first introduced by Sir G. Campbell. The people speaking these languages, settled chiefly in the jungly and mountainous tracts of the Central Provinces, are computed to number about two million, though many tribes, such as the Bhils, who have adopted other languages, especially Hindi, ethnologically doubtless belong to this group. Kolarian speech possesses a very complete suffixal system of inflection, its conjugational system being especially developed. Some of the chief points in which it differs from Dravidian speech are that it has a dual number for nouns, and that it lacks a negative form of the verb. Our knowledge of most of these languages is, however, still sadly defective. Brandreth proposes to include nine different languages under this group, to which Cust adds a tenth; but this scheme is so far only provisional. The best-known member of this family is the *Santali*—spoken by a vigorous tribe inhabiting the so-called Santal Parganas (and adjoining districts) along the western frontier of Lower Bengal—of which we have a good grammar by Skrefsrud (1873). The only other language of this group the grammar of which has been at all adequately treated is the *Mundari*, spoken by Mundas, Bhumij, and Larka Kols; whilst of others, which are probably destined to die out before long, we have as yet only scanty vocabularies.

(4) *Tibeto-Burman Group*.—This field has also as yet been very imperfectly surveyed, most of its languages lying either wholly beyond the Indian frontier, or only just projecting into the British territory. They share the general agglutinative character of the only two literary languages of this family, the Tibetan and Burmese, whilst in them the tone of the voice also plays generally an important part in the meaning of words, though not to the same extent as in monosyllabic languages. Brandreth proposes to arrange these border-languages in nineteen different classes, which Cust re-

duces to a few geographical groups—viz. the Nepal, Sikkim, Assam, Manipur-Chittagong, and Trans-Himalayan groups—the last-named group consisting of the southern offshoots of the Tibetan branch of Tibeto-Burman speech.

A curious cluster of dialects, which seems to be independent of any of the four groups of Indian speech hitherto mentioned, is found in the Khási hills, in the province of Assam. There is a good *Khási* grammar by Pryse. This language, in which five or six dialects are distinguished, is of the monosyllabic order; but its exact relationship has not yet been determined.

The word Hindu has been used in various senses. In truth it means all those who profess the Hindu or Brahmaic faith, which, however, consists of many sects. This vast community of nearly 208 millions of souls is divided into several Castes (q.v.), high and low. The high castes are mainly Aryan; the lower castes partly Aryan and partly Dravidian or aboriginal. A person must be born into the high castes, and cannot enter them by conversion. If a person, as for instance an aboriginal, be converted, he can enter the lower castes only. The sections of Hindu community thus summarised differ not only in nationality and language in different provinces, but in customs and dress. Their languages are to be counted by scores.

The Mohammedan (or, strictly, Muhammadan) population, on the other hand (about 58 millions), in all parts of India affect the same customs, and generally speak one language—Hindustani or Urdu. It is the one chiefly known to Europeans. It is the vernacular in the towns alone, and those, too, of the north-west only. In these provinces, also, it is the official language. It is, however, hardly known to the Mohammedans of eastern Bengal, who speak Bengali. Persian and Arabic are more or less known as classical languages to the Mohammedans of India, but are not spoken. The language of the courts of justice is everywhere the language of the province.

The aboriginal hill-tribes have caused trouble on the Assam frontier at various times, especially those on the north-east frontier near Assam. The hill-tribes of the Dravidian race also are in a primitive state socially. Of these the most important are the Bhils and Gonds, who are found in the Vindhya and Satpura regions, the Khonds and Kols, who inhabit the Eastern Ghats, and the Sontals on the hill-country west of Bengal. The Bhils were wont to live by plunder, and used to burst out of their jungles, committing many outrages; but in 1825, after various methods of subduing them had been unsuccessfully tried by the British government, it was resolved to tempt them into military service, with good results. The Khonds and Kols, driven into the jungles and mountains of Central India by the advance of the Aryan race from the north-west, have preserved the grim religion that prevailed in the country before Hinduism was heard of. That religion may be briefly characterised as Devil-worship, with efforts to propitiate the malignant deities by human sacrifice, principally of children. Successful efforts have been made by the British government to suppress these practices. As a tribe the Gonds are the strongest; they adopted parts of both Hindu and Mohammedan culture, founded a rude dynasty, and signalled their rule by works of material improvement. For more than a century past they have relapsed into their pristine condition. It is from among these aboriginal tribes, numbering in all perhaps fifteen millions, that proselytes to Hinduism are obtained.

National Character.—To the inhabitants of India, who, although generally a mixed race of Dravidian

and Aryan origin, now form many distinct nations, no general statement can apply. The acute but unwarlike inhabitants of the Gangetic delta are quite unlike the less intellectual but sturdier races of the upper basins of the Ganges and the Indus—i.e. the North-western Provinces and the Punjab. These latter again are dissimilar from the high-bred and chivalrous race of Rajasthan or Rajputana, and the hardy though humble Mahratta of the Western Ghâts. Still further varieties are found in the half-warlike and partly refined races of the eastern coast and southern peninsula, mixed up with races of lesser spirit and culture. The races who in this generation are believed to have political aspirations are the Sikhs of the Punjab—the Sikh faith being really an offshoot of Hinduism—the Goorkhas of Nepal, and the Mahrattas of the Western Ghâts; and perhaps some sections of Mohammedans, who might be aided by Arabs immigrating from Arabia. The Brahmans everywhere, to whatever nationality they may belong, or whatever language they may speak, have a homogeneous character, imbued with a lofty pride transmitted through long generations.

The Mohammedans of central Asiatic descent are strict adherents of their faith, and sometimes fanatical. But those who, like the inhabitants of eastern Bengal and of parts of the Punjab, are merely Hindus or aborigines made Mohammedans by conversion, are of course less orthodox. Their religion is a mixture of the doctrines of the Koran with the local idolatry. The Parsees, a mercantile and educated class, seated at Bombay and along the west coast of India, are the descendants of the fugitive fire-worshippers of Persia. See PARSEES.

The national character cannot be portrayed from this congeries of nationalities, yet some characteristics can be set forth as generally prevalent: for the upper and middle classes, domestic affection, munificence, tenacious adherence to custom, veneration with awe leading to superstition, love of external nature, an inclination for abstract meditation, mental acuteness and subtlety, litigiousness, shrewdness of observation; for the humbler classes, temperance, patience, docility, charitableness to the indigent, endurance, fortitude under disaster, and industry. The qualities termed principle and public spirit in western phrase cannot be predicated of any class. Deep attachment to the ancestral religion takes the place of patriotism. 'Dharma' to the Hindu, and Din to the Mohammedan, means virtue under a religious sanction. In justice to the women, it must be said that, despite their subjection and seclusion, they have shown courageous fortitude in times of danger and charitable munificence when endowed with means. The suttee 'widow-burning' evinced supreme resolution. Predatory and pugnacious instincts, hereditary in some classes, are partly subdued by the *pacifomania* of British rule. Politically the leading factor is this, that the congeries of nationalities, despite community of faith, have no idea of national union or of self-organisation. This renders them comparatively easy of government by a foreign power that possesses governing capacity.

Physical Qualities.—These vary together with race and climate. The stature is often tall in the north, and short in the south very much as in Europe. Strength does not depend on height, of course. The Nepàlese are short, so are the Mahrattas; both are strong. As a rule, strength with courage is found more in the north than in the south, but least perhaps in the Gangetic delta. Bengal is the only large province that furnishes no recruits to the army. Physical endurance, the power of making protracted bodily exertion with but scanty sustenance, is perceptible everywhere;

in some places it is extraordinary, and rarely to be equalled in any country. As a point of comparison, a native has hardly half the strength or nervous force of a European, perhaps not more than one-third; his work comparatively would be in the same proportion. In consequence of this and of the cheapness of living, his wages are not more than one-sixth of the British rate. A proposition of this sort cannot be stated accurately or definitely, but some such truth as this lies at the basis of the political economy of the country.

Religion.—Hinduism or Brahmanism is the religion of the great majority of the people, and Mohammedanism comes next. Of the 287,000,000 inhabitants of India, British and feudatory, in 1891, 207,700,000 were Hindus, 57,000,000 Mohammedans, 9,300,000 aboriginal pagans, 7,000,000 Buddhists (almost all in Burma), 1,400,000 Jains, 90,000 Parsees (chiefly in Bombay), 17,000 Jews. In Bengal there are nearly 24,000,000 Mohammedans to 47,000,000 Hindus; in the Punjab, 13,000,000 to 10,000,000 Hindus. The Sikh religion is professed, according to the census for the Punjab, by 1,900,000 of its inhabitants. The Christians number 2,200,000. Buddhism at one period prevailed very generally throughout India; it is now confined to Bhutan, Sikkim, and Burma. See BUDDHISM, JAINS, MOHAMMED, PARSEES, SIKHS.

Hinduism.—The first to be considered is that variety of creeds which is derived from Brahmanic sources, and known as the Hindu religion, or Hinduism. The following summary of the origin and development of Hinduism is from Goldstücker's essay (*Literary Remains*, 1879), originally written for the first edition of this work.

Hinduism may be divided into three periods, the Vedic, Epic, and Purānic, as our knowledge of the first is derived from the sacred books called the *Vedas*, of the second from the epic poems the *Ramayana* and the *Mahabharata*, of the third from the mythological works known under the name of *Puranas* and *Tantras*. Writers on this subject have marked the beginnings of certain divisions of Vedic works with 1200, 1000, 800, and 600 years B.C. The question of Hindu chronology will be more particularly considered in the article VEDA. Probably the latest writings of the Vedic class are not more recent than the 2d century B.C. Uncertainty hangs over the period at which the two great epic poems were composed, although there is reason to surmise that the lower limits of that period are not far from the beginning of the Christian era. The Purānic period, on the other hand, all scholars are agreed to regard as corresponding with part of our medieval history.

The Vedas.—If the *Rig-Veda* the oldest of the Vedas, and probably the oldest literary document in existence—coincided with the beginning of Hindu civilisation, the popular creed of the Hindus, as depicted in some of its hymns, would reveal the original creed not only of this nation, but also of humanity itself. The Hindus, as depicted in these hymns, are far advanced beyond the starting-point of human society. Indeed they may be ranked among these communities already experienced in arts, defending their homes and property in organised warfare, acquainted even with many vices which only occur in an advanced condition of artificial life (see VEDA). Yet the ideas expressed in the greatest number of the *Rig-Veda* hymns are neither emanating from an artificial imagination nor largely affected by philosophy. The Hindu of these hymns is engrossed by the might of the elements. The powers which turn his awe into pious subjection are: *Agni*, the fire of the sun and lightning; *Indra*, the bright, cloudless firmament; the *Maruts*, or winds; *Sūrya*, the sun; *Ushas*, the dawn; and nature in general. He

invokes them, not as representatives of a superior being, before whom the human soul professes its humility, but because he wants their assistance against enemies—because he wishes to obtain from them rain, food, cattle, health, and other worldly goods. He seeks them, not for his spiritual, but for his material welfare. Sin and evil, indeed, are often adverted to, and the gods are praised because they destroy sinners and evildoers. But these words are not to be associated with our notions of wrong. A sinner, in these hymns, is a man who fails to address praises to those elemental deities, or to gratify them with the oblations they receive at the hands of the believer. He is the foe, the robber, the demon—in short, the borderer infesting the territory of the 'pious' man, who, in his turn, injures and kills the other. On the whole these hymns, so far from reflecting unfavourably on the internal condition of the Hindu community, seem, on the contrary, to bespeak the union and brotherhood which existed among its members.

The worship of the elementary beings was originally simple and harmless. Most of the Rig-Veda hymns mention but one sort of offering made to these gods. It consists of the juice of the Soma (q.v.) or moon-plant, which, expressed and fermented, was an exhilarating and inebriating beverage. There is a class of hymns, however, to be found in the Rig-Veda in which the instinctive utterance of feeling makes room for the language of speculation; and the mysteries of nature being more keenly felt, the circle of beings which overawe the popular mind becomes enlarged. Thus, the objects by which Indra, Agni, and the other deities are propitiated, become gods themselves; Soma is invoked as the bestower of all worldly boons. The animal sacrifice is added to the original rites; and the horse of the sacrifice especially is invoked by the worshipper.

Mystical language then shows that religion was endeavouring to penetrate into the mysteries of creation. This longing is expressed in other hymns, which mark the beginning of the *philosophical creed of the Vedic period*. The following extract will illustrate the nature of this third class of hymns, as they occur in the oldest Veda: 'Then there was no entity or non-entity; no world, or sky, or aught above it; nor water deep or dangerous. Death was not, nor was there immortality, nor distinction of day or night. But THAT breathed without allation, single with her who is within him. Other than him, nothing existed which since has been. . . . Who knows exactly, and who shall in this world declare, whence and why this creation took place? The gods are subsequent to the production of this world; then who can know whence it proceeded, or whence this varied world arose, or whether it uphold itself or not? He who in the highest heaven is the ruler of this universe, does indeed know; but not another one can possess this knowledge.'

As soon as the problem implied by passages like these was raised, Hinduism must have ceased to be the pure worship of the elementary powers. Henceforward, therefore, we see it struggling to reconcile the latter with the idea of one supreme being. The first of these efforts is shown in that portion of the Vedas called *Brahmana*, the second in the writings termed *Upanishad*. In the *Brahmanas* the mystical allegories are reduced to a systematic form. Epithets given by the Rig-Veda poets to the elementary gods are spun out into legends. A ponderous ritual, founded on those legends, is brought into a system which requires a class of priests. However much this ritual betrays the gradual development of the institution of castes (unknown to the hymns of the Rig-Veda), there are still two features in them

which mark a progress of the religious mind of the ancient Hindus. While the poets of the Rig-Veda are chiefly concerned in glorifying the visible manifestations of the elementary gods, in the Brahmanas their ethical qualities are put forward for imitation and praise. Truth and untruth, right and wrong—in the moral sense which these words imply—are often emphasised in the description of the battles fought between gods and demons. A second feature is the tendency in these Brahmanas to determine the rank of the gods, and to give prominence to one special god amongst the rest; whereas in the old Vedic poetry, though there may be a predilection to bestow more praise on some gods than on others, yet there is no intention to raise any of them to a supreme rank. Thus, in some Brahmanas *Indra*, the god of the firmament, is endowed with the dignity of a ruler of the gods; in others the sun receives the attributes of superiority.

The Upanishads.—An answer to the question regarding the Almighty is attempted by the 'mysterious doctrine,' as laid down in the writings known under the name of *Upanishads*. Their object is to explain, not only the process of creation, but also the nature of a supreme being, and its relation to the human soul. In the Upanishads the deities of the Vedic hymns become symbols to assist the mind in an attempt to understand the true nature of one absolute entity, and the manner in which it manifests itself in its worldly form. The human soul itself is of the same nature as this supreme or great soul; its ultimate destination is that of becoming reunited with the supreme soul, and the means of attaining that end is not the performance of sacrificial rites, but the comprehension of its own self and of the great soul. Thus the Upanishads became the basis of a comparatively enlightened faith. They contain the germs whence the three great systems of Hindu philosophy arose. They advance sufficiently far to express belief in a supreme being, but acknowledge the inability of the human mind to comprehend its essence. See VEDA.

The Epics and the Philosophy.—The Epic period of Hinduism is marked by a development of the two creeds, the general features of which have now been traced in the Vedic writings. The popular creed strives to find a centre round which to group its imaginary gods, whereas the philosophical creed finds its expression in the groundworks of the *Saikhya*, *Nyaya*, and *Vedanta* systems of philosophy. In the former we find two gods in particular who are rising to the highest rank, Vishnu and Siva; for as to Brahmā (the masculine form of Brahman), though he was looked upon now and then as superior to both, he gradually disappears, and becomes merged into the philosophical Brahma (the neuter form of the same word), which is a further evolution of the great soul of the Upanishads. In the epos *Ramayana*, the superiority of Vishnu is admitted without dispute; in the great epos, the *Mahabharata*, however—which, unlike the former epos, is the product of successive ages, there is an apparent rivalry between the claims of Vishnu and Siva to occupy the highest rank in the pantheon. Already there is a predilection during this Epic period for the supremacy of Vishnu; and the policy of incorporating rather than combating antagonistic creeds led more to a quiet admission than to a warm support of Siva's claims to the highest rank. One remarkable myth illustrates the altered position of the gods during the Epic period. In the Vedic hymns the immortality of the gods is never matter of doubt. The offerings they receive may add to their comfort and strength, but are not indispensable for their existence. It is, on the contrary, the pious sacrificer himself who, through his offerings,

secures to himself long life and immortality afterwards. And the same notion prevails throughout the oldest Brahmanas. It is only in the latest work of this class, and more especially in the Epic poems, that we find the inferior gods as mortal in the beginning, and as becoming immortal through exterior agency. In the *Satapatha-Brahmana* the juice of the Soma plant, offered by the worshipper, or at another time clarified butter, or even animal sacrifices, impart to them this immortality. At the Epic period Vishnu teaches them how to obtain the *Amrita*, or beverage of immortality, without which they would go to destruction.

The philosophical creed of this period develops the notion that the union of the individual soul with the supreme spirit may be aided by penances, such as peculiar modes of breathing, particular postures, protracted fasting, and the like; in short, by those practices which are systematised by the Yoga doctrine. The most remarkable Epic work which inculcates this doctrine is the celebrated poem *Bhagavadgita*, which S'ankara, the great philosopher, declared to be founded on the Yoga belief. The doctrine of the reunion of the individual soul with the supreme soul was necessarily founded on the assumption that the former must have become free from all guilt affecting its purity before it can be remerged into the source whence it proceeded. And, since one human life is apparently too short for enabling the soul to attain thereto, the Hindu mind concluded that the soul, after the death of its temporary owner, had to be born again, in order to complete the work it had left undone in its previous existence. This is the Hindu doctrine of *metempsychosis*. The beginning of this doctrine may be discovered in some of the oldest Upanishads, but its fantastical development belongs to the Epic time.

The Puranas and the Tantras.—The Puranic period of Hinduism is that of its decline, so far as the popular creed is concerned. Its pantheon is nominally the same as that of the Epic period. Brahma, Vishnu, and Siva remain still at the head of its imaginary gods. But whereas the Epic time is generally characterised by a friendly harmony between the higher occupants of the divine spheres, the Puranic period shows discord and destruction of the original ideas whence the Epic gods arose. Brahma is withdrawn from the popular adoration, leaving Vishnu and Siva to fight their battles in the minds of their worshippers for the highest rank. The divine element which still distinguishes these gods in the *Ramayana* and *Mahabharata* is now more and more mixed up with worldly concerns and interseated with historical events, disfigured in their turn to suit individual interests. Of the ideas implied by the Vedic rites scarcely a trace is visible in the Puranas and Tantras, which are the textbooks of this creed. Some Puranas, it is true—e.g. the *Bhagavata*—make in some sense an exception to this aberration from original Hinduism; but they are a compromise between the popular creed and the Vedanta creed, which latter remains the faith of the educated and intelligent. They do not affect the worship of the masses as practised by the various sects, whether harmless, as with the worshippers of Vishnu, or offensive, as with the adorers of Siva and his wife Durga. It is this popular creed which, with further deteriorations caused by the lapse of centuries, is still the main religion of the masses in India. See PURANA and SANSKRIT, Vol. IX. p. 153.

The philosophical creed of this period, which is still preserved by the educated classes, is derived from the Vedanta philosophy. It is based on the belief of one supreme being, who is invested with all the perfection conceivable by the human mind. But the nature of that being is declared to be

beyond the reach of thought, as not possessing any of the qualities by which the human mind is able to comprehend intellectual or material entity. See VEDANTA.

The sects which arose during the third period of Hinduism suppose that their worship is countenanced by the Vedas; but its real origin is derived from the *Puranas* and *Tantras*. There are three chief divisions of these sects—the adorers of Vishnu (Vaishnavas), of Siva (Saivas), and of the wives or female energies of these gods (Saktas). For the philosophy, literature, &c., see SANSKRIT.

The Popular Faith.—This must be noted as it is seen among the Hindus to-day. The trial of Brahma the creator, Vishnu the preserver, and Siva the destroyer is still remembered. One of them (Brahma) has lapsed into an abstraction, and practical adoration is divided between the other two. The Sivaïtes are chiefly, but not entirely, in the north; the Vishnuïtes in the south. The Sivaïte worship is chiefly attracted by the wife of Siva, under various names—Kali, Durga, Parvati, and so forth. Vishnu, again, is almost lost in the worship paid to his two incarnations (avatars), Rama and Krishna. Lesser divinities, such as Hanuman, the 'monkey-god,' and Ganesh, the 'elephant-god,' are also honoured. The sanctity of the Ganges (Ganga) remains, and when the river is lost in the delta that sanctity is to some extent continued to the Hooghly, flowing past Calcutta. The Nerubudda also is sacred. The ling or phallus is still an emblem, and gives its name to the Lingayet sect in the Deccan. It is hard to gauge the thoughts of Hindus regarding a future state. They think of a heaven (Svarga) and a hell; also of giant demons (Rakshas). From their demeanour in the presence of certain death it may be inferred that they expect absorption into the divine essence or entity, through the intervention of the god or gods they have worshipped. It is hard to measure the extent to which this faith may have been weakened by the western education of to-day in the minds of the rising generation. The undermining is, however, extensive. Still, in the upper class there are many who cling to Brahmanic orthodoxy, and with the mass of the people the adoration at the temples, the floral and votive offerings, the ceremonies, the festivals, the pilgrimages, are all maintained. The rule of life is still comprehended in the term Dharma, which includes religious fidelity and moral virtue.

The Caste System, which is a potent factor in the national life, does not appear to have been a part of the Vedic religion originally. But it arose subsequently with a religious sanction which is still maintained. The Brahman caste, including the priests, is held to have something divine in it. Most of the several millions of Brahmans follow secular employment; but even the humblest of them is hedged round by a certain sort of sacredness. This caste, together with the Kshatri or warrior caste, and the Vaisya or trader caste (including the subdivision of Kayasths or writers), are held to be twice-born (dwija). This character does not attach to the Sudra caste, which includes the masses. The restrictions in respect of food and drink (water) in the caste system are most severe and narrow. Caste is lost from any of the infringements that are inevitable in foreign intercourse. But restoration to caste, though often expensive, is sufficiently facile. Within each caste as a division of the people there are subdivisions infinitely numerous, which as a whole have been reckoned at several thousands.

The Brahmans.—But a new religion is arising among the Hindus educated after the western manner: this may be termed Brahmoism or

theism, eschewing caste and almost everything Brahmanic. There are already two divisions—Brahmos and Adhi-Brahmos; perhaps other divisions may be formed. Their community is termed the Brahmo Somaj (q.v.). These theistic reformers look primarily to the Vedas, but refer also to the Christian Bible. This intellectual, moral, and spiritual movement may have infinite development under the national education now established, and is to be reckoned among the phenomena of the country. It has been necessary to pass a special law for the marriages of this sect and other sects.

The Sikhs.—Their faith, though not quite what it was in the preceding generation, is still a living power. In the Punjab and the protected Sikh states it really was a sort of reformation, and a moral system engrafted on Brahmanism. Otherwise it recognises all, or nearly all, the Brahmanic tenets, caste included. Its sacred book, the Granth, is well known. Its spiritual teachers (Gurus) have a status irrespective of the Brahman priesthood, and it has religious orders endowed with fighting qualities. A man is not born into its system, but is initiated. Practically the initiated ones are all Hindus, who thus become Sikhs or disciples. There are two modes of initiation, something like baptism: the first, that of the foot, practised by the founder, Baba Nanak; the second, that of the sword, as practised by Govind Sing, the warlike propagator. The former has more of a religious character, the second is more militant. The popularity of the latter enlivened in the palmy days of the Sikh kingdom, when the temple of initiation at Amritsar, near Lahore, was daily crowded.

Buddhism is now for the people only a *nomine umbra*; probably the words 'buddh,' as abstract wisdom, and 'nirvāna,' as a haven of celestial quiescence, are remembered. In the Eastern Himalayas, Sikkim, and Bhutan it is really Lamaism (q.v.), or the medieval corruption of Buddhism, of which the headquarters are at Lhasa, in Tibet, with the Dalai Lama and the incarnations. The representations of Buddha or Gautama have the aspect of ineffable repose which Buddhism has everywhere exhibited. The caste system does not exist, but the monastic order is all-powerful. In Burma the faith is still mainly that which was settled at the last great council of Asoka, in northern India, before the Christian era. Here also caste is not acknowledged; but the priestly and monastic orders, though they cannot arrogate a status like Brahmins, are very influential.

Jainism is believed to have originally sprung from the same school of speculative thought as Buddhism. It has sacred books and saints of its own, in a long line or series, and it promises a future quiescence hardly distinguishable from annihilation. It has an excessive tenderness for animal life. It recognises caste. Its adherents are largely found in the banking and mercantile classes.

Mohammedanism.—This is, in many parts of the country, strict and exactly preserved, and 'din,' or orthodoxy, is still a word to conjure with. The two sects, Sunnis and Shiāhs, exist in this as in other countries; the dynasties have been mostly Sunni, and the people chiefly belong to that sect, but the Shiāhs have always been numerous at Lucknow. In eastern Bengal, however, the faith is much modified and debased, and this remark applies to nearly half of the Moslem population. The ramifications of the fanatical Wahabi sect in Arabia have spread to the Indian empire, thereby causing occasionally political trouble.

The Parsees preserve the Zoroastrian faith and practice—the fire-worship, and so forth. Their

towers of silence, inside of which the dead are deposited, are conspicuous objects. There are traces still in India of the old worship of trees—the Bo, the tulsi, and others, and of the serpent (Naga). The aboriginal cult consists of veneration for the great spirit and for malignant powers, including smallpox, and even the tiger, with worship of stocks and stones.

Religious Endowments. The several religions have from time immemorial received endowments from the native dynasties, which endowments are in part maintained under British rule. The value of these endowments consisted in the alienation of the land revenue in favour of religious institutions as grantees. The government has severed itself from any share in the management of these institutions, but it regards the landed endowments as property, and has maintained them after due investigation of tenure, title, and the like.

Christianity.—The traditions of St Thomas (q.v.) the Apostle survive in the south, where also a Syrian Church was planted in the early centuries after Christ. In the 5th century Nestorianism came from Babylon, and still survives. In the 16th century Roman Catholic missions arrived from Portugal, and soon afterwards came the famous St Francis Xavier (q.v.) with the Jesuits. The Jesuit missions had great success on both sides of the Peninsula in a certain way, but their ministers were somewhat orientalised. Just two centuries later—i.e. at the middle of the 18th century—the Society of Jesus was broken up in Europe, and the south-Indian missions languished in consequence. Early in the 19th century the society was re-established, and ere long its missions were resuscitated.

The Danish settlement on the south-east coast at Tranquebar saw the first Protestant mission, which was Lutheran, under Ziegenbalg, in 1795. He was followed by Schwartz in the Peninsula. Towards the end of the century the Baptist mission was set up at the then Danish settlement at Serampore. In the early years of the 19th century Henry Martyn, the Church of England chaplain, began to work as a missionary. The bishopric of Calcutta was established in 1814, and then followed the operations of the two great associations of the Church of England—the Church Missionary Society and the Society for the Propagation of the Gospel. The Church of Scotland began its missions in 1830, increased by the Free Church after 1843. These were followed by missions from the Wesleyan and Baptist communities (British and American), from the German Society at Basel, from the London Missionary Society, and the United Presbyterians in 1860. In 1835-37 the bishoprics of Madras and Bombay were established, the Bishop of Calcutta becoming Metropolitan. Recently bishops have been appointed for the Punjab and Sind, and for Burma, besides two missionary bishops for the Peninsula. The Church of England is the official church, and its chaplains are stationed at the principal towns and military cantonments. In many places also there are ministers of other denominations. Roman Catholic priests are ministering everywhere, and many of them are salaried by the government as ministers to the European soldiers of their faith. Besides these there are the European ordained missionaries—many hundreds of all denominations—and under these a fast growing native ministry.

The following was the distribution of the Christian population, by race, in the empire in 1881: European, 142,610; Eurasian, 62,085; Native, 893,658; others (including various Asiatic races), 764,172—total, 1,862,525. The following is accord-

ing to denomination at the census of 1891: Church of England, 295,016; Presbyterians, 40,407; other Protestants, 360,905; Roman Catholics, 1,315,263; Syrians, Armenians, and Greeks, 201,684—total, 2,284,380.

The missionaries have now, for half a century, worked with pastoral devotion, literary labour, and educational efficiency, in western as well as eastern knowledge. They have studied religions, translated the Scriptures into the principal languages, issued numerous works on Christian teaching, supervised schools, founded colleges, managed the cure of congregations. They have long constituted a moral force in the country, with beneficial effect, socially and politically. The increase in the number of native Christians has been proportionally great.

Social Customs.—Four-fifths of the population are affected largely by the caste system already described as being partly at least connected with the popular religion. A religious sanction in some degree attaches to infant marriage, or child marriage, with all classes; also to the seclusion of women, and to the prohibition against re-marriage of widows, with the upper and middle classes. In practice the women of the masses are not secluded, but, on the contrary, appear everywhere, and work out of doors; they re-marry, too, if in widowhood. The burning of widows (suttee or sati) on the funeral pyres of their husbands has long been suppressed by the criminal law under British rule. Polyandry is found only among a few of the aboriginal tribes. Polygamy is sanctioned, but not enjoined; it is, of course, confined to those who can afford to maintain more than one wife. Here, again, in practice the masses of the people are monogamist. In all classes the marriage expenses, arising chiefly from the offerings made to the priesthood, are so excessive as frequently to cause embarrassment to families. Many of the social customs above indicated are regretted and deprecated by native reformers as being injurious to the national progress, and benevolent efforts for reformation are made. The laws of inheritance, dower and divorce, women's property, adoption, partition, and other social matters are held to have a quasi-religious sanction. They are generally observed in the courts of justice under British rule, both for Hindus and Mohammedans. Three criminal practices have been severely dealt with by the British government: female infanticide, arising from the presumed exigencies of caste; the murderous and treacherous Thuggee connected with the goddess of destruction; and the Meriah or human sacrifices by some of the hill-tribes.

The Village System.—This is a factor in the rural life of the Hindus, and from them has been adopted by the Mohammedans. A village does not merely mean a collection of houses, but corresponds to a township or a parish. It is an area of some hundreds or thousands of acres of land, according to circumstances, and is under the administration of hereditary functionaries, the principal of whom is the *potail* (head-inhabitant), a small local magistrate, who superintends the affairs of the community, settles disputes, attends to the rural police and the collection of taxes. Among the other functionaries may be mentioned the accountant and notary (*Kurani* or *patwari*), who keeps a register of the produce and the names of the proprietors, and draws up all deeds of sale, transfer, &c.; the Brahman, or village priest; the schoolmaster; and the watchman. Besides these almost every village has its astrologer, smith, carpenter, potter, barber, and bard, all of whom are rewarded out of the produce of the village lands. Under this simple form of municipal government the inhabitants of the country have lived from time immemorial.

The boundaries of the village have been but seldom altered; and though the villages themselves have been sometimes altered, and even desolated by war, famine, and disease, the same name, the same limits, and even the same families, have continued for ages. The inhabitants give themselves no trouble about the breaking up and division of kingdoms; while the village remains entire they care not to what power it is transferred, or to what sovereign it devolves: its internal economy remains unchanged; the potail is still the head-inhabitant, and still acts as the petty magistrate.

Costume.—This is in these numerous nationalities characterised universally by the ease, lightness, and looseness common in the East and suitable to the hot climate. But it varies in the many provinces, and, indeed, with every nationality. The turban (*pagri*) has every sort of dimension, from minute neatness to turgid massiveness. The waistband (*dhoti*) extends often below the knee, in which case there is no trouser. Jackets in many styles are common. The women's dress in many respects resembles that of the men. The petticoat is not universal. The head-dress is often extended, so as to hang gracefully down the back. The shoe is not always worn; indeed, the humbler classes are generally barefooted. With them the blanket is often a plaid. The black colours of Europe are seldom seen, but indigo blue is common. Otherwise white, set off by gay margins, and rich scarfs and shawls, is the prevailing colour. As a whole the national dress is picturesque, and a holiday crowd has the appearance of a flower-garden.

Architecture.—This is not generally remarkable in the humbler dwellings. In the Gangetic delta the materials are bamboo and thatch, and the cottages, being covered with creepers, are picturesque. In the north both walls and roofs are of indurated earth, the effect being utterly plain. In the south wood and brick are used. The street architecture in the cities and towns is diversified in a manner conducing to pictorial effect. The Europeans have not invented any style for their buildings, except at Calcutta, where the private houses have a stately architecture suited to the climate. Otherwise for their churches they have adopted the Gothic style, and for their civil structures the leading styles of Europe, with certainly a noble, even magnificent effect at Calcutta and Bombay. At Madras, in Rajputana, and elsewhere, they have used adaptations of the old oriental styles.

The indigenous styles of architecture for many centuries have been the chief ornaments of the land. Their study has been greatly elucidated by the Archeological Survey. They begin with the Buddhist era; for the preceding or Vedic era there are no remains. The best authority regarding them is Fergusson, from whose works the following classification is taken. It must suffice to note the salient points only.

The Hindu Styles.—In the Buddhist architecture the characteristic features are, first, the *Tope* (a corruption of *Stupa*, or 'monumental mound'), encased with masonry, having a superstructure at the top, and corridors round the base, with four entrances marked by gateways, often of great beauty; secondly, the *Lat* or pillar, generally monumental; the *Chaitya* or hall of worship; the *Vihara*, or monastery, with cells for the monks. The two last named are often rock-cut, and thus have an extraordinary interest. One tower only, that of *Buddh Gya* in Behar, has been found, and it is one of the noblest dimensions. Almost all parts of the architecture are adorned with bold yet graceful carvings of men and women, and of animals. In some of the rock-cut chambers or cave-temples are remains of frescoes immensely valuable to the student.

The only living architecture of Buddhism is in the Eastern Himalayas, in Sikkim. There the figures of Buddha are beautifully executed in terracotta; and the monasteries are protected from the snow by umbrella-shaped roofs. In Nepal there is one tapering pagoda in the Burmese style. In Burma the circular dagobas have been developed into the exquisitely tapering pagodas, with gilded surface, and the masonry is set off by wood-carving of the most elaborate description.

In the Jaina architecture the original characteristics were somewhat similar—Jainism and Buddhism being cognate faiths. But simplicity begins to be lost in ornament. Extensive remains are discovered on hill-tops far removed from one another—Parasnath in Bengal, Abu in Rajputana, Sauranj in Kathiawar. There is a disposition to congregate small temples in great number on hill-tops, so as to form, as it were, cities of the gods. The general effect of these, however, is not picturesque. The large towers become rounded and ribbed, with a circular addition something like a rose on the apex, surmounted by a finial, so that the general effect is not unlike a spire. Arches and domes become prominent features. Elaborate ornamentation is introduced into the stone masonry. Pillars and lesser towers of great beauty are erected.

The styles which follow are historically Brahmanic. In the Himalayas there are two styles: one in Cashmere, with Hindu affinities, but with greater simplicity of outline and of detail in gray limestone; the other in Nepal, with Chinese and Burmese affinities, the most striking examples being those of temples built in stories, with sloping roofs, copper-gilt, and projecting eaves; the walls being often of enamelled brickwork, and the wood-carving very rich.

The Dravidian style prevails in the southern peninsula, where the Tamil language is spoken. It is called after the old Dravidian race, which has still a distinctive existence in this region. The towers of the temples lose the rounded and spiral forms, and become nearly pyramidal. The temple enclosures have vast gateways (gopuras) of comparatively square shape, though narrowed towards the top. The surface ornamentation, though very fine in some respects, is on the whole grotesquely profuse. At some points, however, the redstone sculptured figures are superb. Granite is largely employed in this style, also the exquisite stucco obtained from shell-lime. The styles heretofore mentioned were devoted almost entirely to religious purposes. But this Dravidian style is adapted to civil uses, and appears in stately palaces, public offices, pavilions, elephant-stables, and so forth. This has been ascribed to the influence of Mohammedan example. The arch becomes prominent; and at Madura especially there is an arched hall of real magnificence.

The Chalukyan style is named after a Hindu dynasty that reigned in the central Deccan. It is found originally in that region, but extended to Mysore, where its noblest works were arrested in their construction by the Mohammedan invasion. Its materials are often of volcanic and granitic stone. The pyramidal shape prevails, and the patient elaboration of surface-ornament excites wonder; but in the general outline stiffness and solidity prevail over gracefulness.

The Indo Aryan or Brahmanic style is more widely spread than any of the others, extending as it does throughout the northern and central regions. Its examples are varied; many are too small to be effective or significant, but some, such as the group near Jaganath, in Orissa, and that at Brindaban, on the Jumna, are of the grandest type. Artistically the Orissa examples are perhaps the

best in the whole country. The forms are influenced by Mohammedan example. The rounded and coroneted tower already mentioned in the Jaina style is found to perfection here. In northern India it is called the Shiwala. This style is adapted not merely to temples, but to cenotaphs for the repose of ashes after cremation, to palaces and summer houses, to fortresses, to the dams of artificial lakes, to travellers' rest-houses, to wells, and to the spacious reservoirs that are famous under the name of Baoli. The domes and lesser cupolas become frequent. The balconies and windows are much to be admired. One palatial summer-house at Deeg, in Rajputana, is one of the most beautiful buildings of its kind in the world. The modern Hindu work chiefly belongs to this style, and is still going on. In general terms, observation of nature, aspiration for beauty, and artistic feeling have characterised the Hindus—whether Buddhist or Jain or Brahmanic and imparted to their architectural achievements an art-culture rarely surpassed by any nationality.

The Indo-Saracenic Style.—This may be divided into two parts, the Pathan and the Mogul. It begins with the 11th century, and ends with the 15th. The early Pathan style, whether in stone, as at Ahmedabad, near the west coast, or in brick, as at Gaur, in Bengal, far eastwards, consists, with one notable exception, of the Hindu architecture already described, but adapted for a simple worship, and modified with a certain breadth of conception to which the Hindus never attained. The exception is this, that sculpture of the human form is excluded, as being idolatrous. The later Pathan style was based on northern models. Plainness and grandeur are its characteristics, both in the northern and the central regions. The dome, the arch, the minaret are nobly developed; indeed, the dome at Bijapur, in the Deccan, is the grandest object of its kind in the world, and is equally remarkable for structural skill.

The Mogul style began with Akbar the Great in the 14th century. At first it appeared in a somewhat Hinduised form, because the Moslem princes married Hindu princesses. But it soon became purified from a Moslem point of view, and resumed the severe simplicity and grandeur of the later Pathan style, superadding thereto a grace and dignity never surpassed in human art. At first the materials were red sandstone and marble intermixed. But by degrees marble was used more and more, till the culminating example of this style, the Taj Mahal at Agra, was encased entirely with this material, inlaid with precious and parti-coloured stones (see illustration at Agra). After this the Pearl mosque (marble) at Agra and the palace fortresses at Agra and Delhi, and the Jama mosques at Delhi and Lahore (Punjab) are the most renowned examples.

The Indo-Saracenic style is applied largely to tombs, it being the practice of the sovereign to erect his tomb in his own lifetime. Besides this class and the other classes of structure, it was largely applied to caravanserais and to educational institutions (*Madrasas*). In all its later stage, it was marked by surface decoration in coloured enamel on earthen material, with hues of which the brilliancy and quality cannot be imitated in modern times. After the break-up of the Mogul empire, a debased modification of the style was introduced at Lucknow. High as was the art culture in the architecture of the Hindu predecessors, it was even surpassed by the Moslem successors.

III. GOVERNMENT AND MILITARY DEFENCE.

The Empire. Since Queen Victoria was proclaimed Empress in 1877, India is an empire, includ-

ing the British territories and the native states, or, in other words, the Indian allies, feudatories, and vassals of the said empire from the Tibetan and Tartar watershed of the Himalayas to Cape Comorin. It includes, too, every area within their geographical limits, without any exception, except the comparatively small settlements belonging to France and Portugal. The empire is under one supreme authority in India—viz. the Viceroy and Governor-general in Council. It may thus be divided into two categories—the British territories, comprising about three-fifths of the total area, and four-fifths of the total population; and the native states. It will be convenient to dispose of the latter first.

The Native States.—The relations between these and the British government are regulated by treaties in full detail. These treaties have been published in many volumes, and form a record of the utmost value to the student of modern India. Some states do not ordinarily appear in the official tables, though they form an integral part of the empire and are in communication with British political agents. In their internal affairs they are uncontrolled. These are the important Himalayan state of Nepal, and the lesser states of Sikkim and Bhutan. The native states which appear in the official tables occupy more than a third of the area of the empire, and contain more than one-sixth of its entire population. They are thus grouped in the census table of 1891:

Native States.	Area in English Sq. miles.	Population, 1891.
Hyderabad.....	82,698	11,537,040
Baroda.....	8,226	2,415,396
Mysore.....	27,936	4,943,664
Cashmere.....	80,900	2,543,952
Rajputana.....	150,268	12,016,102
Central India.....	77,808	10,318,812
In Bengal.....	35,834	3,296,379
" North-west Provinces.....	5,109	792,491
" Punjab.....	38,299	4,263,280
" Central Provinces.....	29,435	2,160,511
" Madras.....	9,609	3,709,622
" Bombay.....	69,045	8,059,298
Total Native States.....	595,167	66,047,487

Hyderabad as given above is exclusive of Berar, which, however, though temporarily administered by Britain, is a part of the Nizam's dominions, with 17,718 sq. m. and 2,897,491 population. Further, the Shan dependencies of Upper Burma contain an estimated population of 2,000,000, which is not included in the above total.

The relations of the native princes to British authority differ very widely. Some are practically independent sovereigns, except that the suzerain power does not permit any of them to make war on one another, or to form alliances with foreign states; while some are under tolerably strict control. As a rule they govern their states under the advice of an English resident appointed by the Governor-general. Thus at every considerable native court there is stationed a British agent, political or diplomatic. There are in all about 300 states, allied or feudatory, great and small; they are divided into allied (with 20,000,000 inhabitants), tributary (about fifty, with 12,000,000), and protected (about ninety, with 18,000,000).

Another classification is according to the religion and race of the native dynasty:

I. Mahratta, with a total population of 6,250,000; a revenue of £3,300,000; and native armies of 60,000 men. The chief states are: (1) Gwalior or Sindhia (pop. 3,116,000); (2) Indore or Holkar (pop. 1,000,000); and (3) Baroda (pop. 2,185,000). These are Hindu in faith, but may conveniently be distinguished from the other Hindu states. See MAHRATTAS.

II. Hindu, nearly 100 in number, with a population

of 27,000,000; a revenue of £8,000,000; and native armies of 188,500 men. Of these the chief are: (1) Mysore (q.v.; pop. 5,000,000); (2) the Rajputana states, such as Udaipur or Mewar (pop. 1,200,000), Jey pore (pop. 2,000,000), Jodhpur (pop. 2,000,000), and some 14 smaller states; (3) the Madras states, such as Travancore, Cochin, Pudukota; (4) the Bombay feudatories, over 30 in number; (5) the lesser states of Central India, including Rewa and Bundelkhand; (6) Punjab states, including the protected Sikh states, ten larger and five smaller, Patiala being the largest.

III. Mohammedan, with a pop. of 14,000,000; a revenue of £5,000,000; and armies of 75,000. The greatest are: (1) Hyderabad of the Deccan, or the Nizam's Dominions (q.v.; pop. 10,000,000, of whom three-fourths are Hindus, though the dynasty and military power are Moslem); (2) Bhopal (pop. 800,000, nine-tenths Hindu by faith); (3) Bahawalpur (pop. 500,000); (4) Some nineteen others with a collective pop. of 2,000,000.

IV. Frontier, mainly Himalayan and eastern Bengal.—(1) Cashmere with Jamu (pop. 1,500,000); (2) the Pathan (Afghan) tribes; (3) Manipur (pop. 200,000); (4) Bhutan (pop. 200,000); (5) Nepal (pop. 2,000,000).

The feudatory states (excluding Nepal, and without counting small states with an aggregate of about 1,000,000 inhabitants, which have no armies) have together armed forces amounting to 350,000 men, and 4300 guns. The flower of this army has on recent occasions been placed at the disposal of the British government as paramount, and is virtually a part of the imperial forces.

The sum total of these four categories would bring the population up to 60 millions, and the total revenue to 15 millions sterling annually. These states are loyal to the British crown as paramount and suzerain. Their loyalty was proved during the imperial crisis of 1857-58. In the aggregate they form a preservative and constitutional force in the country. The British government takes a paternal interest in the welfare and good government of these states. Misgovernment is effectually prevented. Colleges and schools under British auspices are established for the education of young native princes.

As descendants are frequently wanting in these old families, it was important that the principle of adoption should be recognised, otherwise the state might on the demise of the native prince without issue lapse to the British government as paramount. All fears on this account were set at rest by a decree in 1858 sanctioning the right of adoption according to Hindu or Mohammedan law.

The British Territories.—These, containing (with Ajmere, Coorg, British Beluchistan, and the Andamans) 964,992 sq. m. and 221,172,952 souls, are broken up into eight main divisions for civil government. They were originally in three divisions, called presidencies, which have become historic—viz. Bengal, Madras, and Bombay. The old presidencies of Madras and Bombay still survive as units of government under governors in council as of yore; but every area that does not specifically belong to them is considered to belong to the Bengal Presidency. The last-named presidency, being much the largest of the three, has been subdivided into several divisions. Of these subdivisions the three principal are Bengal, with Behar and Orissa; the North-western Provinces, with Oudh; the Punjab, with Delhi. Each of these is under a lieutenant-governor. The three remaining subdivisions are the Central Provinces, Assam, and Burma, each under a chief-commissioner; of these the Governor-general in Council is technically the governor, but he delegates the greater part of his powers to the chief-commissioner in each case.

The subjoined table thus shows these main territorial divisions, with their areas and populations :

Presidencies	Provinces	Style of Government	Area in sq. m.	Pop. 1891
BENGAL	Bengal, Behar, and Orissa	Lieutenant-governor.	151,543	71,346,987
	North-western Provinces and Oudh.	" "	107,503	46,105,085
	Punjab and Delhi	" "	110,007	29,886,847
	Central Provinces	Chief-commissioner.	86,501	10,781,294
	ASSAM.	" "	49,004	5,476,833
MADRAS	BIRMA	" "	171,430	7,005,560
BOMBAY	Madras	Governor in Council	141,189	35,630,340
	Bombay with Sind.	" "	125,144	18,901,123
Total.			942,981	217,537,169

Besides these there are three small detached territories—viz. Ajmere (in Rajputana), Coorg, and the Andaman Islands. All this is exclusive of the Berar province, which, though under British administration, is a part of the Nizam's dominions.

These figures, large as they are, fail to give a definite impression of the enormous area and population under British authority in this part of the globe. The districts under direct British administration have an area almost quite as large as that of the United Kingdom, Austria-Hungary, Germany, France, and Italy together, or more than seven times that of the United Kingdom. The area of the native states is as large as Norway and Sweden, Spain, Holland, and Belgium put together. In population British and feudatory India together have more than all European states together, omitting Russia only. The British territories (without the native states) contain more than one-seventh of the inhabitants of the entire globe.

Machinery for governing.—In 1858 the government was transferred from the East India Company (q.v.) to the crown. In 1877 the Queen assumed the title of Empress of India (Kaisar-i-Hind). The government of India is in the highest resort vested in a Secretary of State in London, who is a member of the cabinet, and has a parliamentary under-secretary and a council of ten to fifteen members. The executive government in India is administered by the Viceroy and Governor-general in Council, acting under the control of the Secretary of State for India. The Viceroy and Governor-general, appointed by the crown, is assisted by an executive council, consisting of six ordinary members (appointed by the crown), each of whom has charge of a department of the executive; together with one extra-ordinary member, the commander-in-chief of the army. This council virtually sits as a cabinet. The legislation for the empire is conducted by a 'legislative council,' composed of the members of the executive above mentioned, together with members from six to twelve in number appointed by the Viceroy and Governor-general. Such is the mechanism of the government of India.

In the several subdivisions of the Bengal Presidency the lieutenant-governors and the chief-commissioners above described, in their executive capacities, rule individually. But two of them, the lieutenant-governors of Bengal and of the North-western Provinces, have legislative councils for provincial legislation. The lieutenant-governors and the chief-commissioners are mainly chosen from the civil service of India. The members of the legislative councils are all appointed, the elective principle not having been as yet introduced. Madras and Bombay are under governors appointed by the crown. Each of them has an executive council, sitting as a cabinet, also appointed by the crown, and a legislative council. With the governor-general, the governors, the lieutenant-governors, and the members of council, the tenure of office is for a term of five years. There are proposals for enlarging the several legislative councils.

The country is divided into territories technically designated 'regulation' and 'non-regulation.' In

the non-regulation territory originally more discretion was allowed to the officials both in the collection of revenue and in the administration of justice. But of late the distinction practically amounts to little more than form, and is technical chiefly. In the regulation districts the judicial service is distinct; in some of the non-regulation it is not. The lieutenant-governorship of the Punjab and the several chief-commissionerships are non-regulation; so are some few outlying tracts elsewhere. The rest of the country is regulation.

The Units of Administration.—The larger units are the districts (generally called collectorships in English and *zillahs* in the vernacular), of which there are in all the provinces above mentioned about 254. Each district, if in regulation territory, is under a collector-magistrate; if in non-regulation territory, a deputy-commissioner. The head of the district has most multifarious and responsible duties: he is fiscal officer, charged with collecting the revenue, as well as magistrate, and besides superintends police, gaols, education, sanitation, and roads. In parts of the non-regulation territory he is also the civil judge, but not in regulation territory. The subordinate officers are deputy-collectors and assistant-magistrates. The district may be compared to an English county or a French department, and varies in size from an area containing 3,000,000 inhabitants to one with only 50,000. Within the district the lowest unit is the village or parish (*mouzah*), according to the village system already described. There are about 570,000 such villages or parishes in the British territories. In all the divisions of the empire, except Madras, the districts are formed into groups, several to each group, under a commissioner. Of these there are more than fifty.

The State Services.—The administration is conducted by members of the Indian civil service (formerly called the covenanted), the great majority of whom are European, though some are natives. The service is recruited from the successful candidates at competitive examinations held in London; but some natives have been allowed to enter the service by nomination, and these are called statutory. To this service most of the higher administrative appointments are secured by act of parliament. The local civil service (formerly called uncovenanted), appointments to which are mostly made by the authorities in India, is composed of Europeans, Eurasians (the offspring of native mothers by European fathers), and natives. Some of the Europeans are appointed in England, especially those who belong to scientific departments. The organisation of the native branches of the civil service, with pay, promotion, and pension, is a feature in British rule, and, together with the state education, is beneficially affecting the national character. Thus, while the direction is in European hands, the great mass of civil officials consists of natives.

The European Community.—Existing mainly at Calcutta, Madras, and Bombay, this body consists of the merchants, manufacturers, barristers, lawyers, and other professional men. This non-official body, together with the official body,

constitutes a force of independent opinion, which is a factor in the progress of the country. It is supported by an English press. The newspapers are published not only at the presidency cities, but also at all the provincial capitals.

The Army.—In 1859 the troops of the East India Company became the Indian military forces of the British crown. The established strength stands at 218,729 officers and men. Of this total 145,177 belong to the native army, and 73,552 are European troops of the regular British army. In the total of the native troops a limited number of European officers is included. The forces were divided into three armies, named after the 'presidencies' of Bombay, Madras, and Bengal. But in 1895 these commands were abolished, and the control of the governors of Bombay and Madras ceased; there are now four commands—Punjab, Bengal, Bombay, and Madras—each under a lieutenant-general, who is under the direct command of the commander-in-chief in India and under the control of the government. Out of 103 batteries of artillery 88 are manned by European gunners. The power and mobility of the army have been vastly augmented by the railway system hereafter to be mentioned, especially in the direction of the fortified military posts on the north-west frontier. The old forts, which are also arsenals and magazines, are maintained at Madras, Bombay, Allahabad, Delhi, Agra, Lahore, and elsewhere. Fort William at Calcutta was scientifically constructed early in the century. The barracks for the European troops have been reconstructed on modern principles, and are among the best structures of their kind to be found in any country. The native troops are recruited by voluntary enlistment, with good prospects of pay and pension, from all nationalities and from all castes, Brahmans or others. Though the regiments are commanded by European officers, there are native commissioned as well as non-commissioned officers. Both classes are usually drawn from the ranks. The drill and discipline are European. Volunteering is largely in vogue among the European communities in the capital cities, on the principal lines of railway, and elsewhere. Several battalions have been formed, which constitute an effective addition of more than 18,000 men to the military strength of the country.

The Maritime Force.—This was for many years furnished by the Indian navy under the East India Company. This was abolished after a long and honourable career, in 1863, and the command of Indian waters was undertaken by the royal navy. Fifteen vessels or more are stationed in these waters, with headquarters at Bombay, under an admiral commander-in-chief; the Indian treasury contributing a yearly sum towards the cost of this arrangement. There is also a marine department at Calcutta, and at Bombay for military transport. Two ironclads for harbour defence are kept in Bombay harbour, which for spaciousness and defensibility ranks in the first class of harbours in the world. Madras has merely an open roadstead. But Calcutta has to be approached by eighty miles of river-navigation, which can be conducted only by pilots of life-long training; and it is therefore absolutely defended by nature. Rangoon, near the mouth of the Irawadi, has a similar advantage, but in a lesser degree. Kurrachee, near the mouth of the Indus, though good, is not large enough for the importance of its situation. To these should be added Aden, which, though a plutonic promontory of Arabia, commanding the entrance to the Red Sea, is yet a part of the Indian system—a first-rate fortification and an imperial coaling station (see COALING STATIONS).

Two great steam-navigation companies, with headquarters in London, but plying in eastern

waters, form an addition to the maritime resources of the country for war or other emergency. Their ships, though officered of course by Europeans, are manned chiefly by Mohammedans from the coast-districts (Lascars), who are excellent sailors.

IV. CIVIL ADMINISTRATION.

Law and Justice.—The fundamental institutions of the Indian empire have been established by parliament in a series of statutes. The regulations of the East India Company provided for civil procedure, leaving the native laws to be observed in social affairs, and British justice to be followed in other affairs. The supreme courts established by the crown in the presidency towns of Calcutta, Madras, and Bombay, towards the end of the 18th century, administered the English law. In 1833 the English government set up a commission to frame a body of substantive law, civil and criminal, for the British-Indian territories. This commission and its successors laboured up to a recent time; and with their help a penal code, a civil procedure code, and several other fundamental laws have been passed. The legislative work, both civil and criminal, is highly scientific as well as practical, and is framed after the best models to be found anywhere. In 1853 a legislative council in India was set up. In addition to this several local legislatures were established in 1861, and these may hereafter be enlarged. About the same time the supreme courts were abolished, and in their stead High Courts were established to control the whole administration of justice inside and outside the presidency towns. Great care has within the last generation been taken with the organisation of the native judicial service under the supervision of the European civil service. Courts of various grades (over 2000 altogether) exist in all parts of the districts already described, so as to be accessible to the people. In such a society as that of India there must needs be defects and shortcomings in the judicial system, but on the whole it commands popular confidence, as is proved by the extent to which it is brought into use. In 1880-89 the number of civil suits in the whole country has risen from 1½ to 2 millions annually, and the value from 14 to 20 millions of tens of rupees. Of these about two-thirds are for small sums of less than £10. In the criminal department about 1¼ million of crimes and offences are reported annually; for these cases about 1¼ million persons are brought to trial, of whom over half are convicted. The suppression of gang-robbery and other crimes of overt violence forms a marked feature of British administration—besides the extinction of the criminal practices mentioned under the head of *Social Customs*. See the *Anglo-Indian Codes*, ed. by Whitley Stokes (vol. i. 1887).

Police and Prisons.—The regular police include a force of 160,000 officers and men; the cost of 15,000 is defrayed by municipalities, and of the remainder by the state. Further, there are besides the village watchmen, about 560,000, corresponding to the number of villages. The constabulary is a native force, the principal officers only being Europeans. It is subject in all respects, except internal discipline, to the magistracy, and in each province is under an inspector-general in each division of the empire. There is one regular constable to 7 sq. m. and 1300 inhabitants—which indicates the peaceful habits of the people. Great care has been taken in the scientific construction and supervision of a prison in almost every district. There are upwards of 230 prisons, with about 82,000 prisoners, inclusive of 12,000 transported to a convict settlement at the Andaman Islands.

Education.—The existing system may be dated from 1854, though various efforts had been made

long before that date. Compulsory attendance has not yet been enacted. Still the attendance at school is considerable, though nothing like what it may yet become. There are three principal universities, at Calcutta, Madras, and Bombay, each having many affiliated colleges; there are also two new universities in the North-western Provinces and the Punjab. These institutions are successful, save in one respect—that very many enter them who do not take degrees; about 14,000 pass the entrance examination annually, of whom less than 3000 take degrees. The educational institutions are of several kinds, public, aided, private and unaided; all together they amount to 134,000 in number, with 3½ millions of scholars. These numbers, though actually large, are not so relatively to the population. Of these students not more than one-twelfth consists of girls. The income comes from various sources, government grants, and provincial revenues, local rates and cesses, municipal funds, and fees paid by the parents; the total amounts to 4½ millions of tens of rupees annually, and the expenditure is, of course, commensurate. The English language, with all the western literature, arts, and sciences, is taught to the upper students everywhere. Much, however, remains to be desired in respect to physical science, and technical instruction is still in its infancy; the native mind seems as yet to lean towards literature rather than the exact sciences, towards the cultivation of the memory and the imagination rather than of the reasoning faculties. But intellectual assiduity is evinced in a commendable degree. There are numerous missionary colleges. Schools of art have been organised in the capital cities; there is an imperial museum at Calcutta, and museums in all the chief cities and towns. The native languages, both classical and vernacular, are also cultivated sedulously. A vernacular literature of primers and elementary works, also of more advanced works, chiefly translations, is springing up under the auspices of the British authorities, vast numbers of such works appearing annually. In the whole country there are about 400 newspapers in the various vernacular languages. Their total circulation is not very great, the largest circulation of any journal being 20,000 copies. They enjoy virtually a complete freedom.

Post-office and Telegraphs.—There are 22,000 post-offices and letter-boxes in the Indian empire, with 41,000 men employed. The number of letters, newspapers, parcels, and packets is in all 375 millions annually. This number is fast increasing; though large actually, it is not very considerable in relation to the population. There are open 32,000 miles of inland telegraph lines, with nearly 3 millions of messages annually. This number is exclusive of the submarine cables.

Trade.—The following figures are taken from the Indian returns, which, owing to differences in valuation and exchange, do not agree exactly with the English returns. The imports in 1894-95 by sea were valued in tens of rupees at 79 millions merchandise (including government stores), 9 millions treasure, total 79; the exports at 109 millions merchandise, and 8 millions treasure, total 116. (In 1894-95 the rupee was approximately equal to 1s. 3d.) Thus the grand total of imports and exports stood at 196 millions. Of the imports more than four-fifths, and of the exports more than half, pass by the Suez Canal. Again, of the imports nearly all come from the United Kingdom; but of the exports, while more than one-half goes to the United Kingdom, a considerable portion is sent to other countries. Of the imports the principal item consists of cotton goods; the next most important is that of metals; other important items are machinery, railway plant and rolling-

stock, manufactured silk, sugar, and woollen manufactures. Among the exports there is no preponderating article like cotton goods among the imports; but the principal items of export are coffee, raw cotton, cotton twist, yarn, manufactures, dyes, grains, including rice and wheat, hides and skins, jute, raw and manufactured, seeds (oil chiefly), tea, wool. The growing exportation of food-grains in vast quantities has disturbed or dissipated any notion to the effect that the increasing population might be in want of sufficient sustenance. Of shipping, 10,893 vessels, with a tonnage of 7,189,465 tons, entered and cleared the ports; of these almost the whole were British, a small fraction only being foreign. All this is exclusive of coasting trade, valued at 80 millions annually, with smaller craft along a coast-line of 7000 miles and more, with 300 harbours, mostly small. There are influential chambers of commerce at the principal seaport towns, mixed bodies of Europeans and natives.

Communications.—The length of railways open for traffic may be stated thus (for 1895): guaranteed companies, 2590 miles; assisted companies, 407; state lines, 14,145; native states, 838—total, nearly 19,000. The total number of passengers on all these lines in 1894 was upwards of 146 millions; the quantity of goods conveyed upwards of 32 millions of tons. The gross receipts of all these lines were well over 25 millions (tens of rupees). The net earnings, after defrayal of working expenses, were 13 millions.

Road-making was being vigorously prosecuted, but became somewhat superseded by the introduction of railways. Several magnificent trunk lines have been constructed. Of the total length in the whole country (60,000 miles) about one-third has been bridged and macadamised. Similarly the railways compete with the old boat traffic on the great rivers. This traffic, however, still exists to a wonderful extent in eastern Bengal, where the boats of varied size and build form a conspicuous feature in the country.

Manufactures.—These, whether in metals or in fibres, have always been very fine, and are still maintained. The local manufactures of cotton goods are very extensive. The beautiful fabrics of all sorts are mostly kept up. The foreign trade, however, has during the 19th century checked the development of indigenous manufactures. On the other hand it has stimulated new manufactures, especially in jute and cotton. The cotton-mills at Bombay, organised on the British model, with British capital and direction, but with native labour, have been considerably developed, and threaten to enter into competition for the Indian market. A factory law, on the English principle, but not exactly with English provisions, was passed in 1881.

Irrigation and Canals.—This subject has owing to climatic exigencies attained vast dimensions. Native dynasties have all distinguished themselves in this direction; drought and famine have always urged every government to action, and the work has been taken up by the British government with its western skill and capital. The Ganges canal with its branches, the canal systems of the deltas of the Mahanadi, the Godavari, the Kistna, and the Kaveri, are among the greatest works of their kind in the world. Great canals are drawn from the five rivers of the Punjab, and the Indus is to Sind what the Nile is to Egypt. These irrigation canals are but little used for navigation. The total length of these and their branches is calculated at 14,000 miles. Besides the canals there are in many districts artificial lakes; wells also for irrigation are found in most of the valleys everywhere. The irrigated area in its grand total is reckoned at 28

millions of acres, of which over 8 millions are watered from canals. The capital outlay on this enormous system cannot be estimated, but the British government has in this way laid out 31 millions of tens of rupees, besides sums spent yearly out of current revenue. The embankments along the Lower Indus and in the Gangetic delta for restraining floods are very extensive, having a total length of about 1500 miles.

Famine Relief.—All this bears on the prevention of famine by state aid. Owing to extensive failures of the monsoon rains at periodically recurring intervals, droughts and famines have occurred. Though the natives bore up against their misfortune with admirable fortitude, and brought out reserves of food such as few nationalities could produce, and though the authorities put forth strenuous efforts, yet the loss of life has been sometimes tremendous. In 1874 the principle was followed of devoting the entire resources and power of the government to the mitigation of distress or the saving of life. In years of plenty a sum varying from 1 to 1½ million sterling is set aside out of current income to meet the cost of relieving distress in time of famine. During the period 1874-80, £16,000,000 was thus expended; in 1896-98 alone, over £4,000,000.

Municipalities.—Municipal corporations (at Calcutta and Bombay elected by the ratepayers) have been established in all the cities and large towns of the empire, their total number being nearly a thousand. The population under their jurisdiction amounts to 14 millions of souls; their annual income to 2½ millions of tens of rupees; and their debt to nearly 5 millions.—In many districts the establishment of district boards, by popular election, for purposes resembling those of county government in England, has been undertaken since 1880.

Vital Statistics and Sanitation.—This subject has for many years past received systematic attention. The water-works at Calcutta, Bombay, and other places rank high among works of this character in any country of the world; and the purification of the drinking-water in many centres of population has beneficially affected the public health. The instruction of the natives as qualified medical men and as medical assistants has for many years been supported by the government. Medical colleges at the capital cities, and medical schools at other places, have been established successfully. There are more than 1500 dispensaries for gratuitous medical relief, which receive about 250,000 persons indoors annually, besides relieving 10½ millions of outdoor patients. There are more than twenty lunatic asylums, with some 3500 inmates. Several millions are vaccinated annually. Sanitation is everywhere a department of state administration; and every province of the empire has a sanitary commissioner. Vital statistics have been collected and compiled. The death-rate for the empire has of late years ranged from 24 to 28·35 per thousand. Of this about 2 per cent. is attributed to cholera, 18 to fever, 1 to smallpox.

Emigration.—Owing to the excessive density of population in several parts of the empire, government has for many years past encouraged and facilitated emigration to the tropical and subtropical colonies, the annual emigration of coolies in 1890-95 varying from 13,000 to 20,000. In 1880-89 the emigration to the Mauritius amounted to 7538 souls; Natal, 8057; British Guiana, 30,142; British West Indies, 39,304; Fiji, 6802; French West Indies, 8712; Surinam (Dutch), 6453—total, 107,008. There is also a considerable migration from the plains and low hills of the central regions to the rice-plains of Burma, and also to the tea-plantations in Assam and in the Eastern Himalayas.

Finance.—The currency is in silver rupees, which alone are legal tender; the subordinate parts of the rupee being sixteen annas, and those of the anna being twelve pai (pies) in copper. The monetisation of silver as sole legal tender to an unlimited amount dates from 1835. There is also a government paper currency, legal tender, amounting to about 16 millions sterling in value. The rupee is nominally equal in value to two shillings; and in former days ten rupees were held equal to a pound sterling. While for Indian purposes the finances were generally exhibited in rupees, of which the higher numbers were a lakh or 100,000, and a crore or 100 lakhs, yet for English purposes they were always exhibited in sterling money; thus, a lakh was reckoned as equal to £10,000, and a crore as equal to a million pounds, and for many years the Indian accounts were exhibited in England in sterling by the process of dividing the rupee totals by ten. In the then relative values of gold and silver this plan answered well, for generally ten rupees were really equivalent to one pound or thereabouts. But during recent years, owing to the depreciation of the rupee, which has fallen at times to below one shilling and fivepence in the exchange, this plan is no longer possible. So now the Indian accounts for England are shown in tens of rupees (or R.x.) whereby the comparison between the figures of recent and of former years is maintained. The finance, then, is shown thus in tens of rupees, for gross revenue and expenditure, excluding capital expenditure on public works. The expenditure is incurred chiefly in India, but partly also in England for India.

Year.	Gross Revenue. R.x.	Expenditure. R.x.
1886-87	77,307,134	77,158,707
1887-88	78,759,744	80,788,376
1888-89	81,006,678	81,659,660
1889-90	81,636,300	82,826,960
1890-94.	90,565,214	92,112,212

There are alternations of surplus and deficit; and after putting one against the other, there had been a surplus during the decade 1881-90. The expenditure has been greatly increased of late years by the depreciation of the rupee. The payments annually to England amount to about 16 millions sterling—for interest on debt, pensionary allowances, and other charges. This sum adjusted in gold has to be paid by the Indian government, which has no money save silver; and in the low state of the exchange these payments become excessive and embarrassing. In order to discharge an obligation of 16 millions sterling India has to remit 23 millions of tens of rupees; thus it is estimated that, as compared with former years, the depreciation of silver has imposed on her a burden of some 7 millions annually (in tens of rupees). The main heads of taxation may be set down in tens of rupees, thus: land, about 23½ millions; opium, 8½; salt, 8½; stamps, 4; excise, 4½; customs, 1½; assessed taxes, 1½; provincial rates, 3½. The grand total of receipts and expenditure has of late years been swollen by the inclusion of the receipts and charges pertaining to the railways.

Excluding the opium, which is really paid by the Chinese (see the paragraph on opium revenue below), the taxation above summarised amounts to nearly 47 millions, and falls at the rate of four shillings per head per annum, which is light. Of the expenditure above set forth, there are 23 millions for the army services, which is about equal to the charges for the civil services of all sorts, exclusive of interest. Besides all this, there is a capital account of outlay from borrowed money on productive works, railways, and canals of irrigation. From 3 to 5 millions annually are thus

laid out by the state, besides a nearly equal sum by guaranteed or assisted railway companies.

Public Debt.—The debt thus incurred stands at 93 millions for railways and 27 for canals; in all 120. Besides this there are nearly 120 millions for other purposes, mainly war. The sum of the two amounts to about 240 millions. Of this sum nearly 120 millions (in tens of rupees) are in India and the rest in sterling are in England. There are also obligations styled 'unfunded debt,' consisting of treasury notes, savings-bank deposits, and other items, amounting to 9½ millions. Further, there were more than 90 millions of capital outlay by railway companies, on which the interest was guaranteed by the government. But this has been modified by the fact of government having recently purchased some of these guaranteed lines. The interest charges annually may be shown thus: on railways, state, 3½ millions tens of rupees; guaranteed, 3¼; irrigation canals, 1; other heads, 5½. The rates of interest have been reduced in recent times, and now range from 3 to 4½ per cent.

Banks.—There is a state or presidency bank with various branches at Calcutta, at Madras, and at Bombay, or three in all. The system of small savings-banks has been greatly extended by the government; there are 6151 such institutions, and 331,711 depositors, with a balance of 6,577,737 tens of rupees. The native bankers, between 200,000 and 300,000 in number, form a numerous community that ramifies all over the country, with a well-established system of bills of exchange (*Hundi*). A plan of life insurance by government has been established for the natives, the effect of which may be considerable hereafter.

Land-tenure and Land-system.—This claims notice on social and economic grounds as well as fiscal. The tax is collected in money instead of in kind, as was often the case under native rule. It consists of a portion taken by the state from the agricultural rent—and much the smaller portion. Apart from this, the incidence of tax on the value of the gross produce is reckoned to range from 4 to 10 per cent. in the several provinces of the empire. In all these provinces, except Bengal and Behar, for the assessment of the tax a survey of every field, besides a general survey of every village, has been made. In every village there is a register showing the ownership, occupancy, rights, and interests in every field. This is revised yearly, and called the Record of Rights. This cadastral survey and this Domesday Book for so vast a country, executed by the British government, together constitute the largest operation of the kind ever undertaken in any age or country. Thus the government has either conferred *de novo* on the people, or recognised as belonging to them from antiquity, something which is equivalent to property in land, whether such property existed under previous native rule or not, which is sometimes doubtful. This property is attended by transactions of sale, mortgage, trust, loan, security. The land-tax is the first charge on it; but it is rendered valuable by the moderation in the assessment of the tax.

As regards the land system, there are several tenures, varied by the conditions under which the tax is fixed. The first is that of *fee-simple* after redemption of the tax, under which government lands are sold to European planters of tea or coffee, and others. The next is that where the tax has been fixed for ever, in Bengal, Behar, Benares, and part of Madras, and is styled *Zemindari*. The tenure in Orissa, Oudh, Sind, and the Central Provinces is similar, save that there the tax is fixed for twenty or thirty years. Next is the peasant proprietary tenure of the North-western Provinces and the Punjab, where the tax is fixed for thirty years, and the

proprietors are grouped together in their villages as communities or coparcenaries; this is styled *Mouzalwari*. Resembling this in all respects except one is the *Ryotwari* tenure of Madras and Bombay—the exception being this, that the *Ryot* or peasant-proprietor is assessed individually for each field he holds. Similar to this is the tenure in Assam and in Burma. The village organisation is almost everywhere preserved.

Below the land-owners, great and small, are the cultivators. They are divided into two categories, the occupancy tenants and the tenants at will. The former inherits his tenure, but as a rule cannot sell it without the owner's consent. He is protected by law against exaction and from interference or eviction, so long as he pays the customary or stipulated rent; and generally his rent cannot be increased against his will without a decision of a court of law.

Opium Revenue.—This is for the most part levied on the exportation of the drug to China; the very small portion consumed in India is taxed under the head of excise. The tax on the exported drug from Calcutta amounts to 6½ millions. The cultivators of the poppy are in British territory; they bring their produce to the government factory, and thence it is sent to the seaport, where it is taken up by the exporters. These arrangements are made to secure the revenue and to prevent illicit consumption. The tax on exportation from Bombay amounts to 2½ millions. The produce is raised in the native states of Malwa and Rajputana.

The *salt-tax* is derived from salt partly obtained on the sea-coast of Madras and Bombay, partly from the salt lake in Rajputana, partly from the rock-salt in the Punjab, and partly imported from England. It is the only tax universally paid by the poor, and falls at the rate of sixpence per head per annum on the population.

Excise.—The farming system which used to prevail in the excise on dings and spirits, for the manufacture of which the materials are to hand everywhere in superabundance, has been condemned as likely to lead to the encouragement of drinking with a population that is generally temperate. This is being superseded by a better system, known as that of central distilleries.

Wages and Prices.—As general facts, both wages and prices have risen under British rule. The labourer of the better class will earn four annas (sixpence) a day, the humbler not more than two annas. The price of food-grain may be roughly taken at one penny for 2 lb. (seer), which supplies a fair sustenance. In a family the women and children earn some wages. Clothing is scanty and cheap; fuel but little needed, and can be got without payment. Rent for cottages is but little known. The masses of the rural population, however, are not labourers, but live on their lands either as owners or occupants. Incomes from land are not assessed to income tax, which at a rate of 2½ per cent. yields 1½ million, and thus represents a taxable commercial and professional income of 60 millions—greatly less than that of England with a population only one-fifth as large. Lastly, there is not, and never has been, anything like a poor-law; nor is there any apparent need for one.

V. THE HISTORY.

Phases of Civilisation.—With a country of 1½ million of sq. m., containing a population of 270 millions, of many languages and nationalities, with traces reaching backwards more than three thousand years, an historical summary would become an Indian jangle of names and dates unless it were arranged on a plan and guided by some leading ideas. Without such a method no lesson from the facts would be conveyed. Now, in these days a

strange and complex civilisation is perceived in the Indian empire, and the student should inquire by what steps through the ages this has been brought about. At the basis of this immense social fabric is the prehistoric status of aboriginal races. Of these races many an indication is still perceptible, and of them some are still surviving. This status was largely affected by inroads, Dravidian and other, from central Asia, many centuries before the Christian era. From one of these invasions, which was Aryan, sprang the early Hindu or Vedic system. Whether any previous invasions had introduced civilisation or not, this Vedic system certainly was a civilised one. This became overlaid with corruptions, and was reformed by the Buddhistic system some five or six centuries B.C. Then came the Greek invasion under Alexander the Great and some of his successors, which affected only the north-western parts of the country. It was followed by other invasions from central Asia, some styled Bactrian, others Saka or Scythian, which extended much further than the north-western regions. Meanwhile Buddhism had strengthened and extended itself till it obtained the sovereignty over the whole country. Thus established as a state religion, it lasted for some centuries after the Christian era. Then it gave way to the old Hindu system, revived under an elaborated form which should be styled Brahmanism, and which represents the modern Hinduism. Brahmanism after its re-establishment in the 6th century flourished till the 11th century A.D., when the first Mohammedan invasion took place. This was followed by successive invasions, till the greater part of the country was subdued and parcelled out into various Mohammedan kingdoms. Many of these kingdoms were subdued by one Mohammedan dynasty known as the Mogul. Thus the Mogul empire was established, embracing most parts of the country, in the 15th century. It lasted for less than two centuries, and then began to shrink. Its fall was precipitated by the rise of the Mahrattas, who brought about a revival of Hindu power on the ruins of the Mogul dominion in the 17th century. Meanwhile European influence was beginning to be felt—Portuguese, Dutch, French—all round the coasts, but not far in the interior. This gave way to the British influence, which was established in the middle of the 18th century, and by the middle of the 19th had spread over the length and breadth of the land, being soon afterwards formally proclaimed as the Indian empire. Thus in the India of to-day are to be found traces of (a) an aboriginal condition with some Dravidian civilisation, (b) a civilisation early Hindu or Vedic, (c) Buddhist, (d) Greek, (e) Bactro-Scythian, (f) later Buddhist, (g) Brahmanic or modern Hindu, (h) Mohammedan, (i) Mahratta, (j) continental European, and (k) British. The following summary will briefly indicate the course of events as concerning the several stages in the national life and the development of the mixed civilisation which is seen to-day.

The Aboriginal.—This is prehistoric, and is both without written record and also without coins or inscriptions; but there are philological traces and rude monuments. Roughly, it may be said that there were at least several aboriginal races, and that incursions of tribes from without took place—not, like subsequent invasions, from the north-west, but from various quarters by sea and land. Rude stone monuments are found, and sepulchral remains with primitive implements have been excavated in several parts of the country widely distant from each other. These are of the highest antiquarian interest. They hardly indicate civilisation, but they prove at least a social organ-

isation of a semi-barbaric character. The population was sparse; the face of the country was a primeval forest, dotted about with cultivation and habitations. The stature of the people was small, the skin dark, and the features of a Tartar cast, with broad cheek-bones, low forehead, nose small, mouth somewhat large. Upon this people, whatever it may have been, two inroads were made, one by a race known as the Kolarian, now represented by the Sonthals, the Bhils, and other tribes; the other, from the north-west, called the Dravidian. The origin of the Dravidians is still doubtful. They must have had some civilisation which spread over the whole country, and which, though absorbed by some subsequent systems in the north, is still traceable in the south. Their race in its ruder form is still represented by hill-tribes, Gonds, Khonds, and others.

The Early Hindu or Vedic.—At least a thousand years B.C.—probably much more, perhaps fifteen hundred—an Aryan race from central Asia descended across the Western Himalayas into northern India through the north-west corner, and gradually spread over the whole country. They were, ethnologically, of the Caucasian or Indo-Germanic type, with fair complexion, straight profile, lofty brow, compressed mouth, tall stature. But their complexion was darkened by sojourn below the Himalayas; their hardihood was softened, while their intellect was refined by the hot climate. They received the name Hindu from Hind, that quarter which they first overran. Their language, the Sanskrit, is one of the most highly elaborated forms of human speech. They brought with them the Vedic religion. They produced the sacred verse of the Vedas and the legends on which the two great epics, the Mahabharata and the Ramayana, were founded in a subsequent century. They formed the rules of social ethics afterwards embodied in a code known as that of Manu, or the moral laws of the Manava priests. They came originally without any divisions of caste, but afterwards their society became broken up into castes, rigidly separated from each other. The first or priestly caste, styled Brahman, was held to have a divine sanction, and was kept separate without intermixture from generation to generation. The two secular castes were those of the soldier (Kshatri) and the trader (Vaisya), including all civil pursuits. These three originally consisted of those who immigrated, but they must have been largely recruited by those whom they found in the country, especially the Dravidians. Below these was the Sudra or low caste, consisting of aborigines and miscellaneous country-folk. At the bottom of the social scale were the Pariahs, who were outside the pale of caste. The dynastic and territorial arrangements of this era are but slightly known, but there were capital cities on the Ganges near the modern Patna and on the site of Allahabad.

The Buddhist.—As the faith and civilisation above sketched became corrupted and overlaid by mythology, a reformer arose, afterwards known as Buddha, a man of a noble family, in the region near the modern province of Oudh. Though his memory has been shrouded by fable and mysticism, he was a real personality. He lived about 500 B.C. The simplified and purified faith as he left it to his disciples had spread largely but not entirely over India by the year 337 B.C., when the Greeks arrived. Up to this time there are no proper materials for composing history. The Sanskrit language, though preserved as a classic, had ceased to be a spoken language. It had been succeeded by a modified form known as the Pali, which was the chief of the local vernaculars called Prakrit.

By this time Jainism had arisen. It is considered

by many to be cognate with Buddhism: at all events it sprang from the same school of speculative thought. It maintained a separate existence on similar if not the same principles, and spread from the western regions, where it first flourished, to other parts of the country. After Buddhism had been banished from the land, Jainism remained, and still continues an effective faith.

The Greek.—Alexander the Great, having invaded India from the north-west corner, penetrated only as far as the Sutlej, and subdued the basin of the Indus and its tributaries—i.e. exactly the modern provinces of the Punjab and Sind. Beyond this his influence was not felt in the main portion of the country. One of his successors, Seleucus, however, entered into relations with Chandra Gupta, a Hindu king of the eastern region, who had not yielded to Buddhism, and whose name was turned into Sandrocottus by the Greeks. For this epoch there are historic materials from Greek sources.

The Bactro-Scythian.—The Greek invasion was succeeded by several invasions of tribes from central Asia. The Bactrians were orientalised Greeks, planted in Bactria or Bactria by Alexander, together with central Asiatic Aryans; of these the records are scanty. The Sakas or Scythians were also Aryans from central Asia. In the absence of records, it is here that numismatics begin to play an important part. Coins have been discovered indicating lines and lives of kings, and dynasties which would otherwise be unknown. These tribes penetrated as far as the central parts of the country, and held their position for some centuries after the Christian era.

The Later Buddhist.—Meanwhile Buddhism had produced some great rulers. In the direct line from the Chandra Gupta already mentioned, there arose Asoka, himself a convert to Buddhism, and the greatest sovereign that ever propagated that faith. He established something approaching to an empire about 230 B.C., his original kingdom being in the lower valley of the Ganges. His general edicts have been preserved. He held several councils, the last of which settled the rule of faith for observance during subsequent centuries. For this era stone inscriptions come into use. Then followed the Bactrian and Scythian invasions already mentioned; but the invaders embraced Buddhism. Thus in a certain sense the several tribes of Aryan invaders became amalgamated, and for some centuries after Christ Buddhism in faith and in civil government prevailed over India. Meanwhile it had spread to neighbouring regions, Ceylon, Burma, Tibet, China, and even Afghanistan. From the visits of Chinese pilgrims recorded on two occasions, separated by considerable intervals of time, much is learned of the then condition of the country. But while the faith endured in those regions, it yielded to the old Hinduism, which should now be called Brahmanism. Before it fell Buddhism raised many architectural monuments in various provinces, which still attest its greatness and culture. Simplicity and purity of faith were its original characteristics, and were probably maintained throughout its Indian career, however much it may have become overlaid by superstition elsewhere. At its best it was probably better than any of the native systems that have succeeded it.

The Brahmanic or Modern Hindu. The subjugation or suppression of Buddhism may be dated from the time of the Brahmanist king Vikramaditya or Vikramajit, in the 6th century A.D. He overcame the Sakas or Scythians, who it is to be remembered had mostly become Buddhists, expelling some, but amalgamating most of them in his own system. He reigned at Ujjain in the Vindhya region. He antedated, so to speak, his era, placing it back

600 years, or 56 years B.C., and this is the Samvat or modern Hindu era. Thus Brahmanism finally superseded Buddhism. Its doctrines were expounded by the reformer Sankar Acharya in the Deccan, but it soon became crusted over with fables and inventions. The time of Vikramaditya has in western phrase been termed the Renaissance of Hinduism. Certainly it was so as regards Sanskrit literature. This language, long dead for all matters save religion, was revived for the drama and for descriptive poetry. Kalidasa, of this epoch, is among the sweet singers of the olden time. There were searchings and efforts after knowledge in astronomy, medicine, and other sciences. The caste system may have lost its religious efficacy for some centuries, but it retained its secular vitality. The Brahman caste had held its own. The other castes had absorbed most of the immigrants from central Asia. Then for full four centuries the Brahmanic system was re-established all over the country. It was upheld by Hindu states at Avantipur in Cashmere, at Ajodhya in Oudh, on the coast of Orissa, at Kanouj and Benares on the Ganges, at Delhi on the Jumna, at Surat on the west coast, at Vijayanagar in the southern Deccan, and elsewhere. It produced many splendid fables, the mins of which delight the modern observer. It was characterised by a fantastic mythology and a somewhat sensuous idolatry. It produced, in addition to the old eode of Manu, a further set of regulations under the name of Yajnavalkya. Minute ceremonial observance, varying for every class, cramped the soul. Thus the spirit of the people was enslaved, their sentiments were cramped, and their thoughts awe-struck. Their mind was turned to superstitious requirements rather than to the practical questions of public life. Their society was further enfeebled by the subjection of women. Maternal and conjugal influence must have existed, but in an irresolvable way. Each one of the countless sections of the community, each tribe or class, each consinhood descending from a common ancestor, within its narrow circle became tenacious of its own traditions, guarding them against all the world, and caring little for anything extraneous. Hence arose the system of village communities, which was consolidated and hardened by the recurring troubles of the time. Each community was a brotherhood within its village only, with cohesion like that of a square of infantry. This institution saved Hindu society during the convulsions of the 11th and succeeding centuries. But a society thus constituted was manifestly a ready prey for northern invaders. During the later part of this era there were apparently some internal revolutions among the Hindus themselves. Then in 1001 A.D. came the Mohammedan invasion. Up to this date the history of the country remains to be written, in the English language at least; the nearest approach to it is Lassen's *Indische Alterthumskunde* (4 vols. 1844-61; 2d ed. 1866 *et seq.*).

The Mohammedan.—In 1001 Mahmud of Ghazni invaded India through the passes of the Suliman Mountains. From this time onwards the history of India can be fully understood from abundant materials, though the details are intricate. Several Mohammedan dynasties in succession established themselves at Delhi, others at Mandu in the Vindhya, at Ahmedabad on the west coast, at five places in the Deccan, of which the two most famous are Goleonda and Bijapur. At all these points architectural remains bear witness to culture and power. Thus almost all India fell under Mohammedan dominion. About the year 1200 the Mongol Genghis Khan devastated the north-western part of the country. Succeeding Mongol invasions were repelled by the Indian Muhamme-

daus, but in 1397 the Tartar Timur or Tamerlane advanced to Delhi and proclaimed himself emperor of India. This title lapsed for a while, till in 1525 his descendant Baber revived it, and became the first who bore the famous title of the Great Mogul. His descendants subdued one by one most of the Mohammedan states in the upper half of India, and became emperors in reality; but the states in the southern half preserved independence more or less. Baber's grandson, Akbar the Great, made this empire effective with the aid of a Hindu minister, Todur Mol. He was perhaps the greatest sovereign that India has ever seen. His code of regulations, the *Ayin-i-Akberi*, is still studied. His reign and the reigns of his three successors were splendid, and their architectural remains evince an artistic culture hardly surpassed in any age or country. Of these three the last was Aurungzebe, a man of masterful ability, disfigured by a cruel bigotry. In his time the empire began to shake, and a new Hindu power was set up—the Mahrattas. After his death in 1707, the decline and fall of the Mogul empire set in rapidly. In the general cataclysm which followed four fresh Mohammedan kingdoms rose to the surface—viz. that of the Nawab Wazir of Oudh, that of the Nizam of Hyderabad in the Deccan, that of the Nawab of the Carnatic, that of Hyder Ali and Tippoo at Seringapatam in Mysore. All four are much heard of in the 18th century. After the fall of the empire the titular Great Mogul remained at Delhi till 1857. The Mohammedan system inculcated simplicity of faith and morals. It was bitterly opposed to idolatry, and was at first iconoclastic, but in the end it extended toleration to Hinduism. It fairly respected the landed property and endowments of that religion. It introduced some fresh ideas, and imparted some breadth of ideas generally, and some improved notions of statesmanship and organisation. Otherwise it produced but little effect upon Hindu civilisation. It imposed its own official language and its own criminal law; but it maintained civil laws and customs for the most part. It undertook no public instruction save that which was Moslem. It planted Moslems all about the country, but did not convert the indigenous people in large numbers anywhere except in one quarter. That exception was eastern Bengal, where the inhabitants embraced the Moslem faith; but how this came about is a question not settled. It has been conjectured that Buddhism survived here without caste, and that the inhabitants were not unwilling to adopt Mohammedanism, as a casteless faith. Be this as it may, the eastern Bengal population has multiplied till it amounts to nearly 25 millions, and is the largest Mohammedan people now existing in any one country. Finally, the Mohammedan power endured so long as it was recruited from trans-Himalayan regions and the hardy north; it soon lost its strength when its supporters came to dwell from generation to generation in the hot country below the mountains.

The Mahratta.—The rising of the Mahrattas against the Mohammedan domination was begun in 1657 by Sivaji in the Western Ghats. Their dominion advanced as that of the Great Mogul receded. It was a low caste Hindu confederation, with a hereditary Brahmin chief at its head, under the title of Peshwa, at Poona in the Deccan. Though it absorbed the Mogul empire, it never overcame the four fresh Mohammedan states above mentioned; but it was the principal power existing when the Europeans appeared in force on the scene. It governed its native Deccan territories tolerably well; and to the north of them it founded several states which still endure prosperously. Still, it had less civilisation than any

power since the Vedic-Aryan invasion, and it threw many parts of the country into confusion. Under its shadow some fresh evils sprung up, such as Thuggee and the organised bandit system known as Pindariy. During this hapless time occurred irruptions under the Persian Nadir Shah and the Afghan Ahmed Shah; but these invaders came, slew, sacked, devastated—and turned back again without permanently affecting the country. In the overthrow of the Mogul power that ensued, there arose a fresh system in the Punjab—viz. the Sikh. A prophet arose named Baba Nanak, who preached a reformation of Hinduism. He was followed by Govind Singh, who established the system by force of arms in the Punjab, and even as far as the Junna. Thence arose a Sikh dynasty, which lasted till the middle of the 19th century. This essentially Hindu power cut off the Indian Mohammedans from what had been their original base in Afghanistan, and left them isolated amidst their foes.

The Continental European.—In the time of the Moguls and the Mahrattas several European nationalities appeared in India as travellers, traders, missionaries. The Dutch had several settlements, of which the memory still remains. The Portuguese, after the discoveries of Vasco da Gama, controlled virtually the whole west coast, excepting Bombay, then a small place. Their headquarters were at Goa, on the coast south of Bombay, which became a town and a harbour of the first rank in the 18th century. The Portuguese influence affected civilisation in the western region to a perceptible degree. In the 18th century the position of the French rivalled that of the English; the wars between the two nations were carried into the East, and the contest was waged on the waters as well as on the land of India. The name of the great Frenchman Dupleix is respected by the British in India as of the worthiest of foemen. Thus the British had to contend simultaneously with French rivals as well as native enemies on Indian soil.

The British.—This begins to be a dominating influence from the battle of Plassey in 1757, won by Clive over the Mogul, which gave to England the dominion of Bengal and Behar, the most populous provinces in the whole country. The British East India Company had been settled in India since 1653. It had three trading-settlements on or near the coast at Calcutta, Madras, and Bombay. These grew into establishments for fighting and governing, and the territorial elements thus formed soon expanded. The acquisition of Bengal with Behar raised the company's territories into a dominion of magnitude. Thus the company in the later half of the eighteenth century appeared as one of the powers. It really rose on the ruins of the Mahratta dominion. Within sixty years from Plassey, that is by 1818, when Poona, under the last of the Peshwas, fell to the British, the East India Company was the master of India as far as the Indus basin, but not in the Punjab nor in Sind. Within these limits it had acquired the whole basin of the Ganges and the coast districts on both sides of the peninsula. The Great Mogul, now powerless, was under its care at Delhi. It had conquered the Mohammedan state in Mysore and restored a Hindu sovereign there. The two Mohammedan states of Oudh and Hyderabad (Deccan) were its dependent allies, though with all honour. It was maintaining many native states, Hindu and Mahratta, in the same position. Among these must be included (after severe fighting) Nepal, the one Himalayan state which was capable of waging war, and which had contended sturdily with British forces. The Pindarries, who raised a robber organisation almost to the rank of a power, had been subdued. The British dominion

had been founded by Clive, preserved during a world-wide crisis for England by Warren Hastings, extended by Cornwallis, and still further advanced by Wellesley, and almost perfected by the Marquis of Hastings. By 1828 there was a Pax Britannica throughout India after centuries of internal war and revolution. How far the East India Company was the aggressor in any of these transactions may be a controversial question. It was often induced to participate in the contests of the native states among themselves; in self-defence it had to fight the combinations formed against its very existence; and being the victor, it had to deal with the vanquished. Thus by various means the fabric of its dominion rose. It had raised a large native army and some European forces of its own, but these had to be sustained by royal troops from England; consequently on each renewal of its charter the company passed more and more under the control of the British government. The next imperial step was in 1825, when the first Burmese war occurred under Amherst; it ended in some acquisition of territory, which was the beginning of a new dominion across the waters of the Bay of Bengal. There was then a development of peaceful civilisation under Lord William Bentinck till 1835. But in 1838 it was decided to set up a native sovereign in Afghanistan under British protection, as a means of guarding the north-western frontier. This led to the first Afghan war, after which the British evacuated that country. This was the first check in a victorious career of eighty years since Plassey. There remained the basin of the Indus yet unconquered—i.e. Sind and the Punjab; the former was conquered under Ellenborough, the latter under Hardinge and Dalhousie after severe fighting in two wars, in which the Sikhs were the aggressors. Thus the Sikh kingdom so ably founded by Ranjit Singh succumbed. Then at length it was said that not a shot could be fired in anger throughout India without leave of the British government. Under Dalhousie also a second war broke out with the Burmese; the result extended British dominion over the delta of the Irawadi. At this time all the works of peace, moral and material, were prosecuted. Shortly after Dalhousie had handed over his charge to Canning the mutiny in the Bengal native army broke out in 1857.

A crisis arose of which the dimensions can readily be gauged by the reader who has followed the various facts already set forth in this article. After the occurrence of some isolated mutinies in the Bengal native soldiery, generally called sepoys, during the early part of 1857, the native portion of the garrison at Meerut, near Delhi, broke out on 10th May; the European garrison failed to prevent them, and the mutineers marched straightway to Delhi, and were joined by the native troops there and by the city mob. The rebels set up as emperor the titular Great Mogul, who dwelt in the ancestral palace there under British protection, and proclaimed the restoration of the Mogul empire. This event was rapidly followed by the revolt of almost the whole native army of the Bengal Presidency. Their comrades of the Bombay Presidency were but slightly affected, and those of Madras hardly at all. At that time the native forces numbered more than 247,000 men of all arms; of these about 50,000 belonged to Madras, 30,000 to Bombay, and the remainder to Bengal; among the latter, however, were many troops called irregular. A large part of the irregular troops remained staunch; but of the Bengal regular troops only seven battalions continued in service. From 80,000 to 90,000 soldiers, horse and foot, were in revolt, having in many cases murdered their officers, and sometimes the European families also. The mutineers, too, who were cantoned over many stations in

broad provinces, held forts, arsenals, treasuries. They were armed with British weapons, had been organised with British discipline, were in possession of much artillery, of a great number of cavalry horses and other transport, and of vast sums of treasure. In Hindustan, in Oudh, and in parts of Malwa, throughout the summer the British power was insulated at certain points, such as the camp before Delhi, the cantonment at Meerut, the fortresses at Agra and Allahabad, the weak fortifications at Lucknow. Elsewhere the European magistracy with their families had been either killed or hunted away, and the court-houses with their records burnt. The disaster extended over at least an area of 100,000 sq. m., with a population of 40 millions. It occurred, too, at the worst season of the year. If not speedily stamped out the fire must spread over the whole country. The year was a centenary of historic events. It was just one hundred years since Clive founded British dominion at Plassey, and two hundred since Sivaji the Marhatta struck a deadly blow at the Moslem power. Many an enemy thought that the knell of the empire had sounded. And certainly, unless the resources of the British Isles could be brought to bear upon the scene of revolt within a few months, the British authority would be narrowed to its three original seats—namely, the presidency towns resting on the sea-board.

At that time there were 40,000 European troops in the country. Several thousand men on their way from England to China at Lord Elgin's disposal were, with his co-operation, diverted to India. Some 40,000 European soldiers were despatched from England round the Cape of Good Hope by a sea-voyage of 12,000 miles. Meanwhile the disasters at Cawnpore and elsewhere in Hindustan had been partially retrieved by Henry Havelock. At the outset a force, largely consisting of Europeans, marched against Delhi. After a severe siege of four months, the place was recaptured by assault. The communications had been maintained continuously with the Punjab, under John Lawrence, as a base whence reinforcements were derived. Native troops were raised from the loyal Punjab in place of the mutineers of Hindustan. Lucknow, for a long while after the death of Henry Lawrence besieged by rebels, was first relieved and afterwards recaptured by a European force under Colin Campbell. The districts were speedily reoccupied by British authority. Though many influential individuals, some chiefs and princes, and some classes, including the worst part of the mob, had joined the rebellion, or rather the military revolt, still the mass of the people in these districts had remained passive, and readily returned to their allegiance. The principal native princes and their states had set an important example of loyalty. Within six months of the outbreak the imperial danger was surmounted, though troubles lasted here and there, and the embers smouldered for more than a year, especially in the hilly parts of the central regions. The cost of suppressing this rebellion is reckoned at 40 millions sterling. Unlike all the earlier foreign dynasties, the British power had never been naturalised or domesticated in the country, but was then, as ever, recruited constantly from the British Isles. Its officers serving in the country had been born and educated in Europe, and possessed as a reserve against danger all the imperial qualities of their race.

Many causes were assigned for the Indian mutiny. The greased cartridges served out to some of the Bengal troops operated as an immediate provocation. The Brahmins were too numerous in the ranks; they were fanatical, and they had the brains to contrive mischief when discontented. The Kabul disaster had broken the spell of invincibility.

bility. Certain chiefs near the scene of the outbreak were labouring under a sense of wrong, real or supposed. Some native states had been alarmed at British policy with regard to the right of adoption. The annexation of Ondh, however righteous in itself, had induced many Mohammedan conspirators to excite mutiny, and to turn it to political account. This brought about a very unusual combination between Mohammedans and Hindus. Still, these and other lesser causes would never by themselves have brought about such a crisis as that which has been described. The prime, the fundamental cause was a large and simple fact, namely this. The native forces were much too large relatively to the European. There was only one European soldier to six native soldiers, whereas now there is one to two. The sepoys then had the physical force in their hands, and they knew it. The distribution, too, of these excessive numbers aggravated the peril. The sepoys were, as already seen, in charge of the stations containing the state resources, civil as well as military. It was the sense of power which gave them the mind to revolt. Their interests, including employment, pay, pension, and the like, were indeed bound up with the British rule. The government was over-slow to believe that the men would revolt to the destruction of their own prospects. But their conduct proves that there are moments when religious fanaticism, national sentiment, pride, and passion will prevail over self-interest. The occurrence was only a question of time, and many will wonder why it did not happen before. But an analysis of historic circumstances would show that never before had a complete opportunity offered. Mutiny of particular bodies of troops had often occurred already, and had been overcome. Thus the British authorities came to be insufficiently alive to the symptoms which portended the events of 1857. But after the storm had burst they evinced qualities rarely surpassed in the annals of the nation, and the history of the time is aglow with genius, valour, and capacity.

The crisis past, no time was lost in rectifying the military faults which had rendered the revolt possible. The native troops were reduced in number, the European troops were augmented. The physical predominance at all strategic points was placed in the hands of European soldiers, and almost the whole of the artillery was manned by European gunners.

Peace and order having been restored to the empire in 1858, various changes, constitutional and other, were made. The East India Company, the greatest corporation ever known to history, ceased to exist, and the government was assumed by the British crown. The army was reorganised so as to guard against the danger from which the country had just been saved. As compared with the relative proportions of former times, the European force was doubled, while the native force was reduced by more than one-third. Thus, as already seen, the European and the natives were as one to two; moreover, the European was placed in charge of the strategic and dominant position, so that the physical power was now in his hands. The dominion was consolidated by the work of peace under successive viceroys, Elgin, Lawrence, Mayo, Northbrook, with material improvement and moral progress. In 1878, under Lytton, a second Afghan war was waged, which led to the strengthening of the north-western frontier. The work of peace was continued under Ripon till 1881, when, under Dufferin, it became necessary to proceed against the king of Ava, and subsequently to annex Upper Burma. This measure, following previous annexations, brought the whole Burmese dominion and the entire region of the Irawadi

in India in contact with China. The year 1896-98, under Lord Elgin, saw famine, the plague in Bombay, earthquakes in Assam, and a troublesome but successful war on the north-western frontier. British civilisation, by legislation, by peace and order, by education, by works of material improvement, by Western ideas, is moulding the mind of nearly all the nationalities in the empire.

Books of Reference.—There is not space here for attempting a review of Anglo-Indian literature, which is very extensive. Some few works only will now be mentioned, which are of a comparatively popular character and are readily accessible. For history, the best-known works are those by Mill and Thornton, and the shorter one by Marshman. Regarding special periods, Mountstuart Elphinstone, for the Mogul era; Keene, for the decline and fall of the Mogul empire; Grant-Duff, for the Marhattas; Malleson, for the French in India; Kaye, for the first Afghan war; Kaye and Malleson, for the war of the mutinies in 1857-58; Trotter and Maine, for the Victorian era. Much light is derivable from the biographies of Clive, Warren Hastings, Metcalfe, Macaulay, the Lawrences (Henry and John), Mayo, and Dalhousie. There are also recent histories of India from the earliest times by Trotter (1890), Talboys Wheeler (1891), and H. G. Keene (1893); of Ancient India, by Romesh Chunder (3 vols. 1889-91); of the British Dominion in India by Sir A. Lyall (3d ed. 1894); of the Portuguese in India, by Dauvers (1894); a series of 'Epochs of Indian History,' edited by J. Adams; and valuable papers on the Indian Mutiny, selected by G. W. Forrest. See also the *Imperial Gazetteer of India* (2d ed. 11 vols. 1885-87), edited by Sir W. Hunter, and his *Indian Empire* (3d ed. 1893); *Modern India*, by Campbell, *Modern India and the Indians*, by Monier Williams (1889); *India Past and Present*, by Samuelson (1889); *India in 1889*, by the present writer; *Our Indian Protectorate*, by C. L. Tupper (1893); *The Protected Princes of India*, by W. Lee Warner (1894); *The Land Revenue of India*, by Baden-Powell (1893); and *The Conversion of India*, by Dr George Smith (1893); also Curzon's *Russia in Central Asia* (1893), and Dilke's *Problems of Greater Britain* (1890). To these should be added the reports by the government on the moral and material progress of the country, and the volume of statistics published annually by the Indian Office in London. The *Journal of the Royal Asiatic Society* and the *Calcutta Review* supply quite a mine of materials. Some light is thrown on this great subject by Tod's *Rajasthan*, Rajendralal Mitra's *Antiquities of Orissa*, Rhys Davids on Buddhism, Franqui on the Parsees, Talboys Wheeler's *Mahabharata and Ramayana*, abstracted in English; Max Muller's analysis of oriental religions; the translations of the sacred books of the East; Barth's *Religions of India* (Eng. trans. 1882); Monier Williams' *Indian Wisdom*, and his *Brahmanism, Buddhism, and Hinduism* (1889); Lyall's *Asiatic Studies* (2d ed. 1884), Edward Thomas' *Numismatic Essays*, and Fergusson's *History of Indian Architecture*. Indian architecture is illustrated at the articles on AGRA, BENARES, ELEPHANTA, ELLORA, &c. And see amongst others the following articles in this work:

Afghanistan.	Clive.	Madras.
Akbar.	Dalhousie.	Mahrattas.
Aurangzebe.	Dupleix.	Mohammed.
Bengal.	East India	Sanscrit.
Bombay.	Company.	Sikhs.
Brahma.	Ganges.	Siva.
Buddhism.	Hastings.	Sue. Canal
Calcutta.	Humbuya.	Sutter.
Canning.	Indus.	Volas.
Caste.	Jams.	Vishnu.
Ceylon.	Juggernaut.	Wellsley.

India. STAR OF. See INDIAN ORDERS.

Indiana, the thirty-first state of the American Union in area, and the eighth in population, is centrally situated between 37° 47' or 180 1800 in P. S. and 41° 50' N. lat., and in 84° 49' or 180 1800 in E. B. Lippincott —88° 2' W. long. It is bounded or 180 1800 on the N. by Lake Michigan and Michigan state, on the E. by Ohio, on the S. by Kentucky, from which it is separated by the Ohio River, and on the W. by Illinois, the Wabash River being the line

of division a part of the way. Its greatest length north and south is 276 miles, its average breadth 140 miles, and its area 36,350 sq. m. The coastline on Lake Michigan is about 60 miles.

The surface of the country has a slight slope towards the west and south-west, the highest point, near the eastern boundary, being 1250 feet above sea-level. Drainage is in four main directions: through the St. Joseph River to Lake Michigan, the Maumee River to Lake Erie, the Kankakee River to the Mississippi, and the Wabash and other streams to the Ohio; small streams intersect the state in every direction, and in the northern part there are numerous small lakes. The northern half of the state is generally level, except for occasional irregular ridges forming 'divides' between streams. Hills increase in frequency from the centre of the state to the south and south-east, and along the Ohio 'knobs' 200-500 feet high are almost continuous, with deep gorges and river-bottoms between. Much of the north-western regions is inundated with water the greater part of every year; but this land is being actively reclaimed by a system of drainage. The fertility of the soil, whether clay or sandy loam, is greatly increased by a vast system of under-draining, there being in 1888 nearly 25,000,000 yards of drain-tiles in use.

The minerals include coal, bog and hematite iron ores, and stratified limestones and sandstones in abundance, ochre beds, kaolin, fireclays, and some gold. The actual workable coalfield covers an area of 6900 sq. m. The production of coal of all kinds amounted in 1870 to 437,870 tons, in 1880 to 1,449,496 tons, and in 1888 to 3,140,979 tons, mostly block coal, although there is also abundance of bituminous and some cannel coal. The natural gas field, the centre of which is in Delaware county, 40 miles N.E. of Indianapolis, has been developed since 1886, and \$6,000,000 was invested in 1888 in the business of supplying it for fuel, there being 395 wells in twenty-three counties. In 1897 there were 2000 wells in twenty-eight counties, with an average flow for each of 2,000,000 cubic feet daily. In the gas region, and in the districts within reach of its pipes, it became for a time almost the exclusive fuel, and also came into use as an illuminant. But by-and-by the supplies of gas began to give out (see GAS-LIGHTING), and the coal supplies resumed their old importance. In 1897 the number of tons of coal raised was 3,706,401, while 65,000 casks of petroleum were obtained. Building-stone and whetstones are plentiful. Devonian, Silurian, and Carboniferous are the chief geological formations. The climate is healthy, but very variable; the winter is severe but short; and summer is hot in the 'Hoosier State,' as Indiana is nicknamed—nobody knows why, though many stories are told.

The principal industry is agriculture, the chief crops being maize, wheat, oats, rye, barley, buck-wheat, potatoes, and tobacco. Some 250,000 gallons of wine are made yearly. The state is surpassed only by Minnesota and Kansas for the amount of its wheat crops, and by Iowa for maize. Flax and sorghum are raised, as are also enormous quantities of apples and peaches. Dairy produce is exported. Wool, honey, maple-sugar, cider, and vinegar are made, and fruit and vegetables are preserved. About a third of the state is still under wood.

The manufactures of Indiana present great variety, and are often important. Among the largest manufacturing concerns of their class in the world are the wagon and plough factories at South Bend, the manufacturing of flour-mill machinery and carriages at Indianapolis, the plate-glass works at New Albany, and the encaustic tile works at Indianapolis. Indianapolis has also the second largest packing establishment, and is at the head of the

sofa-manufacture; Indiana, indeed, turns out more furniture than any other state of the Union, largely made from the valuable timbers of the Wabash and its tributaries. In 1886 there were 11,885 manufactories, with a capital of \$51,490,656. The value of raw material used during the year was \$91,872,291; of products, \$158,562,729; wages and other expenses, \$31,211,152. In 1890 there were 12,384 manufactories with 124,349 workers, producing in the year a value of \$227,000,000. At that date (the census year) the manufactures of the state had increased tenfold in thirty years. The trade is almost wholly internal, though Michigan city has trade with Canada; navigable rivers and canals greatly facilitate commerce. The central position of Indiana compels all main through-lines from the east and west to cross the state. In 1880 there were 4020 miles of railway in operation; in 1895, 10,000. The Wabash and Erie Canal, the largest in the United States (476 miles), has 374 miles in Indiana; and another canal (75 miles) extends from Lawrenceburg to Hayestown. The Ohio is navigable throughout its length within the state, and on it over fifty Indiana steamboats ply; the Wabash is navigable to Lafayette, and its branch, the White River, for about 60 miles.

The population in 1800 numbered 4577 whites and 163 coloured, 135 of the latter being slaves. In 1860 the population was 1,350,428; in 1880, 1,978,301; and in 1890 it was 2,600,000. The cities with over 30,000 of a population in 1890 were Indianapolis (165,436), Evansville (50,756), Fort Wayne (35,392), and Terre Haute (30,217). Great attention is devoted to education. In 1888 the children of school age numbered 756,989, of whom 514,463 were enrolled in the common schools. The number of teachers was 14,204, of school-houses 9882; the revenue for the year was \$5,235,032. There are a state university at Bloomington, the Purdue University and state institute of technology at Lafayette, and the state normal school at Terre Haute, as well as a hundred high schools; instruction at all these is free. Not under state control are 14 universities and colleges, and numerous academies and special schools. In most of the colleges, as in the common schools, the sexes are educated together.

The state is divided into ninety-two counties. The governor is elected for four years. The general assembly, composed of fifty senators and one hundred representatives, meets every two years. Indiana has two senators and thirteen representatives in congress. The judges of the supreme court, five in number, are elected for six years.

History.—Indiana was discovered by La Salle in 1671, and constituted part of New France. In 1763 France ceded the country to Great Britain; by the treaty of 1783 it became a part of the United States, under the general term of the north-west territory, which later was divided into the territories of Ohio, Indiana, Michigan, Wisconsin, and Illinois. In 1816 Indiana was admitted to the Union, and the state government was finally settled at Indianapolis in 1825. By the ordinance of 1787 slavery was prohibited in the territory. The Indian troubles resulting from the influx of settlers culminated in the battle of Tippecanoe (see HARRISON, W. H.) in 1811. Indiana supplied five regiments for the war with Mexico, and during the civil war furnished for the government service 208,367 men, of whom 24,416 were killed or died of disease.

Indianapolis, the capital and largest city of Indiana, is on the west fork of White River, on a level plain, near the centre of the state, 195 miles SSE. of Chicago by rail. It is a regularly-built and beautiful city. Its streets, many of them 100 feet wide, for the most part cross at right angles; but

four main avenues, radiating from a central park, cross the others diagonally. The principal buildings include a handsome new state-house (completed 1888), a fine county court-house, a city hall, a prison for women, a large state asylum for the insane, and other asylums for the blind and deaf and dumb; and the city possesses an imposing monument to the soldiers and sailors who fell in the civil war. It has also two medical colleges, numerous schools, and nearly a hundred churches. Indianapolis is one of the chief railway centres of the United States, fifteen main lines converging here. The trade in agricultural produce is very considerable. Pork-packing is the leading industry, but there are also large flour and cotton and woollen mills, numerous foundries, and manufactories of furniture, carriages, tiles, &c. (see INDEX A). The site of Indianapolis, then covered with dense forest, was selected for the future capital in 1820, and the city was founded in 1821. In 1860 the pop. was 18,113; (1870) 48,244; (1880) 75,056; (1890) 105,436.

Indian Army. See EAST INDIA ARMY.

Indian Corn. See MAIZE.

Indian Cress. See NASTURTIUM.

Indian Fig. See BANYAN, PRICKLY PEAR.

Indian Fire, a bright white signal-light, produced by burning a mixture of 7 parts of sulphur, 2 of Realgar (q.v.), and 24 of nitre.

Indian Ink. See INK.

Indian Ocean. The Indian Ocean is bounded on the W. by Africa, on the N. by Asia, on the E. by Australia and the Australasian Islands. According to modern geographers it is limited to the S. by the 40th parallel of south latitude, in which region it opens widely into the Southern and Antarctic oceans. It gradually narrows towards the north, and is divided by the Indian peninsula into the Bay of Bengal on the east and the Arabian Sea on the west, the latter sending northward two arms, the Persian Gulf and the Red Sea. Within these limits the Indian Ocean is estimated to have an area of 17,320,500 sq. m.

At the dawn of history the Indian Ocean was known as the Erythrean Sea; the Phenicians are said to have been familiar with this southern ocean at a very early date. Necho, an Egyptian monarch who flourished about 610 B.C., is reported by Herodotus to have sent some of his vessels, manned by Phenicians, into the Erythrean Sea with orders to return by the south of Africa and the Columns of Hercules. Whether or not this voyage ever took place, it appears certain, from their reports as to the position of the sun to the north of them, that these early navigators penetrated far south (see GEOGRAPHY, Vol. V, p. 145). From a very early date there was a coasting trade between India and the Persian Gulf, but the voyage of Nearchus, one of Alexander's generals, from the Indus to the Persian Gulf, is the earliest reliable record of these coasts. Hippalus, an Egyptian navigator who flourished about the beginning of the Christian era, was the first to observe the regular alternations in the direction of the monsoons of the Indian Ocean, and to profit by them to open up a direct route across the high seas from the Red Sea to India. The shore routes were henceforth abandoned, and a fresh impulse was given to voyages into oriental waters. In the 9th century the Arabs made frequent voyages across the Indian Ocean, Soleiman of Sirof being probably the first to cross the Bay of Bengal and pass into the China Sea. In 1486 the Portuguese rounded the Cape of Good Hope, and in 1498 Vasco da Gama reached the coasts of India by the same route. In 1521 the one remaining ship of Magellan's squadron crossed the southern Indian

Ocean in completing the first circumnavigation of the world.

The mean depth of the Indian Ocean is estimated at about 2300 fathoms, or slightly greater than that of the Atlantic (q.v.). The greatest depths are in the eastern part to the south of the equator, where it is estimated that there are fully 50,000 sq. m. with a depth of over 3000 fathoms. Over 13,000,000 sq. m. of this ocean's floor lie between the depths of 2000 and 3000 fathoms.

The area of land draining into the Indian Ocean is estimated at 6,813,600 sq. m., and the annual rainfall on this land is equal to 4379 cubic miles of water. The rivers flowing from the Asiatic continent are by far the most important, and they carry an immense amount of detrital matter into the Bay of Bengal and Arabian Sea, these forming extensive deposits of lime mud. Along the African coasts, in depths from 100 to 1000 fathoms, there are great deposits of glauconitic sands and muds, and on these as well as other coasts there are coral muds and sands, and lime and green muds in the shallower depths. In the deeper parts of the ocean, far from land, there are vast deposits of red clay, Radiolarian ooze, and Globigerina ooze. In the Southern Ocean, towards the Antarctic, the bed of the ocean is covered with a Diatom ooze.

The temperature of the surface waters of the Indian Ocean varies much in different parts of the ocean, and at the same place at different times of the year or states of the wind. In tropical regions the temperature usually varies from 70 to 80° F., and the yearly range is only 7° or 8° F. Off the Cape of Good Hope and off Cape Guardafui, however, the annual range of temperature may be from 20 to 30° F. For instance, sudden and great changes of temperature are often noticed off Cape Guardafui when the wind blows off shore, for in this way cold and deep water is drawn up along the African coast to take the place of the warm surface water which is driven eastward by the wind.

The temperature of the water at the bottom of the Indian Ocean is very uniform and subject to little, if any, annual variation. In the Bay of Bengal and Arabian Sea temperatures of 33·7° F. and 34·2° F. have been recorded at the bottom; these are not more than the fraction of a degree higher than those observed by the *Challenger* in 50° of south latitude. It is certain, therefore, that this deep cold water is slowly drawn into the Indian Ocean from the Antarctic to supply the place of the warm surface currents that are driven southward by the winds. The currents of the Indian Ocean are less constant than in the other great oceans, and are largely controlled by the direction and strength of the monsoons (see MONSOONS). Some of the most characteristic coral atolls and islands are to be found towards the central part of the Indian Ocean, such as the great Maldive group, the Chagos, Diego Garcia, and the Cocos Islands. Almost all the tropical shores are skirted by fringing and barrier reefs. Christmas Island is an unpraised coral formation. St Paul's, Mauritius, Rodriguez, and others are of volcanic origin, while Madagascar, Ceylon, and Socotra are typical continental islands.

Indian Orders. Three British orders of knighthood take their name from India. (1) The Imperial Order of the Crown of India, instituted 1st January 1878, consists of the Queen, certain of her daughters and daughters-in-law, of numerous native Indian princesses, and the wives and other female relatives of the viceroy of India, the governors of Madras and Bombay, and the Principal Secretary of State for India. (2) The Most Exalted Order of the Star of India, instituted in 1861, and enlarged in 1866 and 1878, consists of

the sovereign, a grand-master (the viceroy for the time being), and three classes of members—Knights Grand Commanders (G.C.S.I.), of whom there may be 30; Knights Commanders (K.C.S.I.), of whom there may be 72; and Companions (C.S.I.), 114 in number. The badge of the order is a light blue ribbon with thin white stripes, and the motto 'Heaven's Light our Guide.' (3) The Most Eminent Order of the Indian Empire, instituted in 1878 to commemorate the proclamation of the Queen of England as Empress of India, and enlarged in 1886 and 1887, consists of the sovereign, a grand-master (the viceroy for the time being), and three classes of members—Knights Grand Commanders (G.C.I.E.), Knights Commanders (K.C.I.E.), and Companions (C.I.E.). The motto of the order is *Lapromptis Auspiciis* ('Under the favour of the Empress').

Indian Red, a silicate of iron, imported from the Persian Gulf.

Indians, RED. See AMERICAN INDIANS.

Indian Shot (*Canna indica*), a plant common in almost all tropical countries; a herbaceous perennial, with a creeping root-stock (*rhizome*), and a simple stem, formed by the cohering bases of the large, tough, ovate oblong leaves. It belongs to the natural order Marantaceae. It derives the name Indian Shot from the seed, which is hard, round, and about the size of a very small pea. The seed yields a beautiful red colour. The root-stocks are very large, spongy, and jointed, and are used in Brazil for emollient poultices in tumours and abscesses. The root-stocks of some of the other species of *Canna* are more valuable, yielding the starch called Tons-les-mois.

Indian Territory comprises a portion of the region originally set apart by the United States government as a home for Indian tribes. It is bounded N. by Kansas, from which it is separated by the parallel 37° N., E. by Missouri and Arkansas, S. by Texas, from which it is separated by the Red River, and W. by Oklahoma Territory. The line dividing these two territories is exceedingly irregular, and Oklahoma lies both W. and N. of Indian Territory. Beginning at the N. this boundary is formed by the meridian 96° W., the parallel 36° 10' N., and the meridian 96° 37' 30" W. to the N. Fork of the Canadian River. S. and W. of this stream the line is continued by the meridian 96° 47' W. to the Canadian River, by that river to the meridian 98° W., and thence S. to the Red River. The section of land situated S. of Kansas and E. of Texas and the Public Land Strip, known as the Cherokee Outlet, is also described as a part of Indian Territory, although it is under the jurisdiction of Oklahoma (q.v.), of which it will ultimately become a part. The area, not including the Cherokee Outlet, is 31,000 sq. m.

The surface of the territory consists mainly of rolling prairie land rising gradually from the southeast toward the N. and W. In the south east the surface is broken by low ranges of the Ozark Mountains which cross the Arkansas border. The most important groups are the San Bois and Shawnee. In the south-west are the Arbuckle Mountains. The mineral resources are practically undeveloped, but coal, copper, iron, marble, and building stones are known to exist in considerable quantities. The territory is well watered, and is drained by the Red and Arkansas Rivers and their numerous tributaries. The river bottoms are wide and fertile, subject to overflow in the spring, and usually enclosed between bluffs which rise abruptly to the intervening uplands. The north-eastern part is well wooded, and a belt of forest, known as the 'Cross-timbers,' extends from the Arkansas River to the

Brazos in Texas. The black bear, brown bear, antelope, and deer are abundant; wild turkeys, prairie-hens, and sage-hens also abound.

Indian Territory when first established included all the hitherto unmorganised portion of the Louisiana Purchase, and was designed for occupancy by the tribes then east of the Mississippi. During the years 1833 and 1834 the Creeks, Choctaws, Chickasaws, and Cherokees were removed to their new home. In 1838 the Seminoles were added, and the remnants of several other tribes followed shortly after. Treaties were made by the government, covenanting to maintain the title of the country to the Indian tribes. The original grants extended northward from the Red River, including portions of what are now Kansas and Nebraska, and westward to the 100th meridian. By subsequent treaties with the Indians, the United States acquired control of the country N. of parallel 37°. A strip of land between the parallels 36° 30' N. and 37° N., and between the meridians 100° W. and 103° W., later known as the Public Land Strip, was, after the annexation of Texas, for a time erroneously reckoned as a part of Indian Territory.

In 1866 the United States purchased the western portion of the various grants to be allotted to other Indian tribes or to freedmen. At the same time, the Seminoles, who had parted with their entire domain, purchased a portion of the land ceded by the Creeks. Tribes whose homes were west of the Mississippi have at various times been settled on these lands. By consent of the Indians, part of these lands were in 1889 and 1890 thrown open to white settlers, and the organisation of Oklahoma reduced Indian Territory to its present limits.

The Cherokees, Choctaws, Creeks, Chickasaws, Seminoles, and some of the smaller tribes at or near the Quapaw Agency in the north-east have made considerable progress in civilisation. Schools and churches have been established. There are excellent farms and cattle ranges, and commerce has gained some foothold. The Missouri, Kansas, and Texas Railway crosses the territory from N. to S. Before the civil war the Indians owned negro slaves, and during the war some of the civilised tribes sided with the South, and for a time were considered to have forfeited their lands. The territory comprises three divisions, partly under the jurisdiction of United States courts and partly under tribal jurisdiction. The judicial centre of the first district is at the Quapaw Agency, of the second at McAlester, and of the third at Ardmore.

Population at the census of 1890, 186,490, of whom 177,682 are members of the five civilised tribes (with descendants of former negro slaves), and the remainder are Indians on reservations. See the articles AMERICAN INDIANS, OKLAHOMA, CHEROKEES, &c.

India-rubber. CAOUTCHOUC, or GUM ELASTIC, a substance which, on account of its peculiar properties, is extensively used in the arts. It is found in the milky juices of plants, and most abundantly in the natural orders Moraceae, Artocarpaceae, Euphorbiaceae, Apocynaceae, and Asclepiadaceae. It exists in the milky juice of plants growing in temperate climates; but it is only in tropical and subtropical countries that it occurs so abundantly as to be of economical importance. The principal South American tree is the *Hevea brasiliensis* or *guianensis*, also called *Siphonia elastica*, or *Jatropha elastica*, a Euphorbiaceous tree; also the Mexican *Castilleja elastica*, which is Artocarpaceous. In the East the *Ficus elastica* (of the order Moraceae), akin to the Banyan (q.v.), is a tree of noble proportions, the appearance of whose glossy leaves is well known in Europe from small specimens grown in pots as ornamental plants. Various Apocynaceous trees (Willughbeia, Landolphia, Ureola,

&c.) yield commercial quantities of rubber in Malaya, Borneo, and Central Africa. The name *Caoutchouc* is from a Carib or Central American word *Cachucha*.

Some of the properties of india-rubber must have been known in America at a very early period, because balls made by the Haytiens of the *gum of a tree*, bouncing better than the wind-balls of Castile, are mentioned by Herrera in his account of Columbus's second voyage. In a book published in 1615 Juan de Torquemada mentions the tree which yields it in Mexico, describes the mode of collecting the gum, and states that it is made into shoes; also that the Spaniards use it for waxing their canvas cloaks to make them resist water. More exact information was furnished by M. de la Condamine in 1735. India-rubber was at first known as *Elastic Gum*, and received its present name from the discovery (about 1770) of its use for rubbing out black-lead pencil marks, for which purpose it began to be imported into Britain in small quantities about the end of the 18th century, being much valued by artists, and sold at 3s. the cubic half inch. Even before this time its employment for the manufacture of flexible tubes for the use of surgeons and chemists had been successfully attempted; but it was not till 1820 that its employment began to extend beyond the rubbing out of pencil marks. Its application to the manufacture of waterproof cloth first gave it commercial importance. About the same time a method was discovered of fabricating articles of various kinds by casting india-rubber in moulds. Its elasticity and flexibility, its insolubility in water, and its great impenetrability to gases and fluids in general have now been found to adapt it to a great variety of uses; but for by far the greater number of its applications it is now employed in the vulcanised state.

The india-rubber of commerce is obtained most largely from South America, but considerable quantities are also procured from British India, the Indian Archipelago, the west coast of Africa, and the Mauritius. During the year 1888 the imports of this material into Great Britain were as follows:

From Brazil	cwt.
West Coast of Africa	196,617
Africa, other parts	43,443
United States and Central America	7,352
British India	9,435
Portugal	21,889
Other Countries	11,276
	29,288
Total	229,350

In 1852 the total imports were only 15,269 cwt.; in 1862, 59,703 cwt.; in 1876, 157,509 cwt.; in 1883, 229,101 cwt.; in 1887, 237,511 cwt.; in 1888, 218,171 cwt.; and in 1889, 236,275 cwt. In 1883 the average price per cwt. was 318s.; in 1885, 220s.; in 1887, 228s.; and in 1894, 216s. The value of imports in 1883 was £3,652,817, and in 1888, £2,553,341. In 1894 the import was 302,451 cwt. (including that from Nyassaland and Congo Free State) valued at £3,272,104. India rubber goods worth over £1,000,000 are exported from Britain.

India rubber is sometimes collected by cutting the trees down, which is a very ruinous process, and resorted to mainly that a greater quantity may be obtained. The more usual method, however, is by making simple incisions in the trunks. In a few hours the juice which flows out fills clay basins placed to receive it. It is solidified and dried by various methods, sometimes spread out in thin layers and dried in the sun or the smoke of fires, sometimes (in Central America) coagulated by leaves of a kind of vine. A good tree will yield four ounces of juice daily, and twenty gallons in a season; a gallon producing 2 lb. of good rubber. Adulteration is not uncommon.

Pura india-rubber is the best, and commands the highest price in the market (averaging about 3s. per lb.). The other South American kinds are of fair quality. East Indian rubber, though naturally a fine quality, is often injured by adulteration and careless collecting.

Commercial india-rubber is a tough fibrous substance, possessing elastic properties in the highest degree. Reduced to the temperature of freezing water (32 F.) it hardens, and in greater part, if not entirely, loses its elasticity, but does not become brittle. When heated, as by placing in boiling water, it softens and becomes very much more elastic than at ordinary temperatures, though it does not in any degree dissolve in the water. If suddenly stretched to seven or eight times its original length it becomes warm; and if kept in this out-stretched form for several weeks it appears to lose in great part its elastic properties, and in this condition is readily cut into those thin threads which are used in the *elastic* put in bonnets, &c., and the elasticity of which is readily renewed by the application of gentle heat. Of late years, however, elastic thread is usually prepared with vulcanised rubber. Commercial india-rubber is insoluble in water and alcohol, is not acted upon by alkalis or acids, except when the latter are concentrated and heat is applied, but is soluble in ether, chloroform, bisulphide of carbon, naphtha, petroleum, benzol, and the essential oils of turpentine, lavender, and saffrafs. Many other essential and fixed oils, when heated with rubber, cause it to soften, and produce thick glutinous compounds, especially linseed-oil, which, in the proportion of $\frac{1}{4}$ lb. of the oil to 4 oz. rubber in thin strips of films, yields a solution which, when strained, is of great use in rendering shoes, cloth, &c. waterproof. When heated to 248 F. rubber fuses; and at 600 it is volatilised, at the same time undergoing decomposition, and yields a liquid called *Caoutchoucine*, possessing great solvent powers over india-rubber and other substances.

To purify the raw material it is boiled for some time in large tanks, which softens it and in some measure releases the solid impurities with which it is often mixed. It is then put through powerful machines which masticate and reduce it to shreds, and while undergoing this operation a stream of water is constantly running over it and thoroughly cleansing it from all impurities. It is then rolled out into thin sheets and hung up to dry in a room heated by artificial means, and thus freed from all moisture. Or, after cleansing, the material undergoes a process of kneading under very heavy rollers, which causes the adhesion of the various pieces of rubber to each other, and ultimately yields a mass or block of rubber in which the condensation is so perfect that all air-holes and other cells and interstices disappear. The block of rubber is then cut under water by powerful knives or shears into sheets, from which bands or thread may be obtained. In the manufacture of square threads mere cutting is had recourse to; and the delicacy of the operation may be understood when it is stated that one pound of rubber will yield 32,000 yards of thread. The round elastic thread is prepared from rubber which has been treated with about double its weight of bisulphide of carbon, containing about 5 per cent. of alcohol, which yields a soft material resembling in consistence bread-dough or putty; and this being squeezed through a series of small holes, produces minute round threads, which are first received on an endless piece of velvet, and ultimately on an endless web of common cloth 500 to 600 yards long, during the transit of the threads across which the solvent or bisulphide of carbon evaporates, and

leaves the india-rubber. When it is wished to weave these threads into cloth they are wound upon bobbins, taking care to stretch the rubber as much as possible, so as to deprive it for the time being of its elasticity; and, after it has been woven into the cloth, a hot iron is passed over the fabric, and immediately the rubber resumes its elasticity.

The method for making waterproof clothing or 'Mackintoshes,' the first application of rubber on a large scale, suggested by Professor Syme in 1818 was patented in 1823 by Charles Macintosh of Glasgow. In this manufacture the caoutchouc has to undergo many and varied processes. It is first reduced to a solution with naphtha or other solvent, and it is then amalgamated with other ingredients according to the nature of the material it has to be applied to. It is then spread on the surface of the cloth, a process formerly done by hand, but now by means of spreading machines, which apply it in very thin coats, so thin that with pure para proofing as many as twelve coats are spread to make the cloth air-proof, but so thin is each coat that the twelve only measure one ninety-sixth part of an inch; for ordinary waterproof purposes, however, five or six are generally sufficient. For double textures the cloths are then pressed together between heavy rollers. These cloths are all vulcanised, and this can be performed by a number of processes—by the 'cold' process, by vaporising, by steam, and by dry heat. The garments are then cut out from the cloth, and fastened together by means of pure rubber cement, which make the edges adhere.

The variety of garments now made up are almost endless, and every year the demand for them in fashionable designs and cloths is increasing.

Vulcanised or Solid India-rubber.—Pure india-rubber is now used only to a limited extent in the arts, but it is applied in the vulcanised state to a very large extent. The remarkable change which caoutchouc undergoes when mixed with sulphur and heated, according to circumstances, from 240° to 310° F., was discovered by Charles Goodyear, in America, in 1834-44, and independently, about the same time, by Mr Thomas Hancock, in England. In the process of vulcanising, the rubber, as a preliminary step, is either torn into shreds or crushed into thin pieces by machinery, and afterwards washed. There are two principal kinds of vulcanised rubber, one hard and horny in its texture, the other soft and elastic. In the case of the former the caoutchouc is mixed with about one-third of its weight of sulphur, and heated for several hours, the temperature finally rising to fully 300° F. For the soft kind of vulcanised rubber, on the other hand, a much smaller proportion of sulphur is required—viz. from 2½ to 10 per cent., and the heat to which it is subjected in the vulcanising chamber is considerably less. Usually, too, with this latter kind, the articles are made before the rubber is heated. The sulphur is commonly added in the ground state, but sometimes the rubber is treated with some solution containing this element, such as the bisulphide of carbon.

Although sulphur is the only essential ingredient required for vulcanising rubber, yet other substances are usually added. Thus, in the case of machinery belting, pipes, and some other articles, the silicate of magnesia (French chalk) is used to prevent adhesiveness. Litharge, or carbonate of lead, again, is frequently mixed with the rubber and sulphur for certain purposes; but there is really a long list of materials more or less used in preparing different qualities of vulcanised caoutchouc, each manufacturer using mixtures the exact nature of which he is careful not to divulge. Asphalt, tar, lime, lampblack, whiting, rosin, sulphide of

antimony, and ground cork are some of the ingredients most commonly employed in this way. Belting for machinery and some kinds of tubing are formed of alternate layers of canvas and vulcanised rubber.

Natural caoutchouc, as already stated, is elastic, cohesive, impervious to gases, insoluble in water, and resists many chemical reagents; but it loses its elasticity by cold, softens by heat, and is destroyed by many fixed oils. After being vulcanised caoutchouc has its elasticity greatly increased, is not hardened by cold, and does not soften or become viscid at any temperature short of its absolute decomposition. Besides, it is barely soluble in turpentine, naphtha, and the other solvents of pure caoutchouc; nor does oil readily penetrate or soften it. Very often, however, the natural oil in some cloths, or oils used in manufacture, tend to make the rubber decay, and this has often caused rubber-manufacturers a large amount of trouble.

It would be a hopeless task to attempt to specify the many useful purposes to which vulcanised caoutchouc is applied, even if we had the space to spare. From the year 1843, when it was first made, to the present time the various patented applications of it must be thousands in number. The mere abridgments of the specifications connected with this material, issued by the English Patent Office, form a thick volume. Under the head GOLOSRES will be found a brief description of the process of making india-rubber shoes. Both coats and shoes of this material have, however, the objectionable property of preventing the escape of moisture from the skin. Belting, linkers, wheel tires, washers, valves, pipes, fire-hose, and other engineering appliances form a large branch of the rubber-trade. For medical and surgical purposes many articles are made of this material. Of such an apparently trivial matter as vulcanised rubber thread one English firm turns out about 3000 lb. per day, and another single small article—viz. tobacco-pouches—is made in another factory at the rate of 3000 per diem.

Hard vulcanised rubber, termed vulcanite, and sometimes ebomite, is made into a great many small articles, such as combs, chains, bracelets, boxes, penholders, paper-knives, knife-handles, buttons, &c., as a substitute for materials like horn, bone, ivory, and jet. Like these substances themselves, it is formed into various objects by moulding, cutting, carving, polishing, and other processes. Vast numbers of these articles are now sold. The black colour of vulcanite ornaments has still a tendency to turn gray, but the brittleness which was a fault of combs made of it a few years ago seems to be overcome. With respect to objects of considerable size, vulcanite has been made into furniture, ornamental tiles, and even rails for railroads and paving for footpaths, for which latter purpose it suits admirably. A kind of vulcanite is now very largely employed as an insulator in electric cables.

India-rubber when melted at 308° F., and mixed with half its weight of slaked lime, forms a useful cement or lute, which can be easily loosened, but it will dry and harden if red lead is added. A very tenacious glue is formed by heating caoutchouc, coal-tar, and shell-lac together. It forms an ingredient in some special kinds of varnishes, and it also improves the lubricating qualities of mineral oils when a small quantity is dissolved in them.

In Great Britain some of the large india rubber factories employ over 1000 hands, and smaller works are springing up all over the country. The exports are sent all over the world, principally to the Continent, North America, and Australia. The duty levied on this class of goods is prohibitive of the expansion of the trade with the United States. The manufacture of india rubber is also carried on

extensively in the United States and France. In most rubber factories a large number of the work-people are females; and, as no great skill is required on the part of the operatives engaged in some departments, employment in such works has proved a boon to many persons who have never learned a trade.

The high price of raw india-rubber has led to many attempts to produce a substitute, but none of them equal in durability the pure caoutchouc.

Indicator-diagram, a diagram drawn on an *indicator-card* by the pencil of the *indicator* of an engine at work. The object in view is to ascertain the relations between, and also the product of the varying pressure and the corresponding variations of volume of, the working substance—steam, explosive gas mixture, hot air, or other material. The latter, the variations of volume, are, in a cylinder, well represented by the movements of the piston; the former, the varying pressure, may be followed by making the steam, &c. press out the piston of a small side-cylinder against the resistance of a spring. If a pencil be attached to this piston it will mark on a piece of paper or card held in contact with the point a straight line traced and retraced with varying velocity. If the steam be shut off from this side-cylinder the pencil assumes the position of 'no pressure.' If now, on the other hand, the piston of the main cylinder be made to draw the paper or card past the pencil point in a direction at right angles to the former, the varying velocity with which a straight line is traced and retraced on the paper will reproduce the varying velocities of the main piston itself. If these two actions be now combined the pencil will move, say, up and down, while the paper will oscillate or be unrolled backward and forward. The pencil-point will accordingly describe upon the paper an irregularly-curved figure which will, in uniform working, be a closed curve, and will always tend approximately to reproduce itself during each successive cycle of the engine. Upon the scales on which the linear traces of the pencil represent, in directions at right angles to one another, the variations of pressure and the piston-movements respectively, the *area* enclosed by this curve will represent the work done by the engine during each cycle; and its *form* enables the actual pressures and volumes of the working substance to be traced out for each successive portion of the cycle, and thus enables the working of the engine to be carefully studied in detail. For examples see *Holmes, The Steam-engine*; and *Dugald Clerk, Gas-engines*. See article GAS-ENGINE for diagrams.

Indiction, a period or cycle of fifteen years, the origin of which is involved in obscurity, but which was originally a fiscal term. It began to be used in reckoning time, chiefly by ecclesiastical historians, during the life of Athanasius; it was afterwards adopted by the popes, who still continue to use it, and through whose influence it came to be so generally employed during the middle ages that the dates of charters and public deeds of this era are expressed in indictions as well as in years of the Christian era. The first indiction is supposed to have commenced on September 24, 312, the day of Constantine's victory over Maxentius. If we reckon backwards to the commencement of the Christian era it will be seen that 1 A.D. does not correspond to the 1st, but to the 4th year of an indiction—hence, *if to any given year of the Christian era 3 be added, and the sum divided by 15, the remainder will give the position of that year in an indiction*—thus, 1890 A.D. was the third year of an indiction. Of course such a method of marking time was necessarily incomplete, for it included no statement of the number

of indictions which had elapsed since the first adoption of that method of computation.

Indictment. See CRIMINAL LAW.

Indies. See EAST INDIES, and WEST INDIES.

Indigestion, or DYSPEPSIA, properly includes only such derangements of the digestive process as do not depend on any recognisable structural change. But it is very common to apply the term loosely to any digestive disorder, whatever its cause may be. In this sense dyspepsia is a symptom of a multitude of diseases, in the description of which, when it is sufficiently important, it will be found noticed. Functional dyspepsia, the dyspepsia of otherwise healthy people, is what will be considered here. Of this there are two chief varieties, the *atonic* and the *irritative* or *acid* dyspepsia. The former is caused by deficient secretion of the gastric juice and diminished movement of the stomach walls, and it is often associated with a want of vitality in the system. The latter is frequently found in persons of vigorous and robust frame and of active habits; and in many cases it is to be looked upon as the result of an excess of digestive activity leading to the accumulation of an abnormal amount of acid products in the stomach, especially toward the end of digestion. This form is more common in men than in women, and is rarely met with before adult life.

The symptoms of dyspepsia differ considerably in different individuals. The appetite is often good, and sometimes voracious, but it may be deficient. For some time after eating there may be no discomfort; but sooner or later pain comes on in the region of the stomach, at first dull, afterwards more severe. A feeling of fullness and distension follows, accompanied by flatulent discharge and the eructation of a sour liquid. The discomfort may sometimes deepen into nausea and vomiting. The pain occasionally shoots up towards the shoulders, and may run down the left arm, like the pain of angina pectoris. From this, however, it may be distinguished by the fact that it comes on after food. The pain is due partly to over-sensitiveness of the stomach, and partly to the irritation of its acid contents, especially of butyric acid. When the pain is of a paroxysmal character it is called Gastralgia or Gastrodynia. Cardialgia or heartburn, and Pyrosis or water-brash, are common symptoms which have also been dignified with special names. The former is said to be caused by the irritation of the upper end of the stomach by the fumes of its acid contents, while the latter is essentially an abortive act of vomiting accompanied by a gush of saliva (Roberts).

In the treatment of indigestion the diet should be strictly regulated. The experience of the patient is often a better guide as to details than all the dicta of the faculty. The food should be properly cooked and well masticated, and the interval between meals should neither be too long nor too short. Where the appetite is feeble food must be taken frequently, in small quantities at a time; and it is often advantageous to use substances which have been partially digested with pancreatic or peptic extract. A mixture of animal and vegetable food is in general more easily digested than either kind taken exclusively. Mutton, fowls, and game are the most digestible kinds of animal food; roast beef is to be preferred to boiled; but pork and all cured meats, such as salted beef, ham, tongue, and all greasily-cooked dishes should be avoided. Cheese, pastry, raw vegetables, such as salads, cucumbers, &c., must also be prohibited. As a rule, dyspeptic persons would probably do well to avoid all stimulating drinks; but in some cases a little cold, weak

brandy and water, or a glass of old sherry, or a little bitter ale may be taken with advantage.

It is of great importance to attend to the bowels (see CONSTIPATION). Regular exercise in the open air should be enjoined. Riding exercise is of special service where the liver is out of order. In some cases change of scene and occupation is of more benefit than anything else. In the medicinal treatment of dyspepsia a host of remedies are in vogue. Acids (especially nitro-hydrochloric acid), either before or after meals, bitters (such as quinine, calumba, gentian, quassia, and hops), and nux vomica increase the appetite and aid digestion. Pepsin is a valuable adjuvant. Nausea and vomiting may be checked by hydrocyanic acid, chloroform, and creosote in very small doses, or by ice and alkalis. Hyposulphite of soda, sulphurous acid, and carbolic acid act well when the vomiting depends on fermentation. For flatulence, bismuth, cardamoms, charcoal, sulpho-carbolate of sodium, hot water, and many other remedies are in use. For the pain in the stomach the subnitrate of bismuth in drachm doses has a well-merited reputation. Spirits of chloroform, followed by hot water, may also be used. The subcutaneous injection of morphia gives effectual relief for the time, but it should not be employed without advice. In nervous dyspepsia, hydrochlorate of cocaine in doses of a quarter of a grain has lately been used with success.

Indigirka, a river in the Siberian government of Yakutsk, rises in a western off-set of the Stanovoi Mountains, and, after a northerly course of 870 miles through a desolate and frozen desert, falls into the Arctic Ocean in 71° N. lat. and 150° E. long.

Indigo (Gr. *Indikon*, 'Indian drug'), a most important vegetable dyestuff, yielding a beautiful blue and very durable dye, the basis also of the best black dye in woollen cloths. It has been used in India from a very early period, and was imported thence by the ancient Greeks and Romans, but was lost to Europe during great part of the middle ages—although the cultivation of the plant and preparation of the dye were described by Marco Polo in the 13th century—until re-introduced by the Dutch about the middle of the 16th century.



Indigo Plant (*Indigofera tinctoria*);

a, raceme of seed-pods. (From Bentley and Friemen.)

The plants that yield the best indigo belong to the genus *Indigofera*, of the natural order Leguminosae, sub-order Papilionaceae. *Indigofera tinctoria* is the species most generally cultivated in India. Central American and West Indian indigo is the produce of *I. anal* and *I. quatinola*.

Indigo is, however, obtained from plants of other genera, particularly from *Wrightia tinctoria* (natural order Apocynaceae), East Indies; *Baptisia tinctoria* (natural order Leguminosae), North America, which yields indigo of a pale colour and very inferior quality; *Tephrosia tinctoria* (natural order Leguminosae), Malabar; *T. Apollinea*, Egypt

and Nubia; *Marsdenia tinctoria* (natural order Asclepiadaceae), in Sylhet; and *Polygonum tinctorium* and *P. Chinense* (natural order Polygonaceae), China and Japan.—In times when East Indian indigo was not known, or was brought to Europe only in small quantity, the same dyestuff was obtained from Wood (q.v.).—A coarse kind of indigo, called Bastard Indigo, was also at one time made in North America from the young shoots of *Amorpha caerulea* and *A. fruticosa* (natural order Leguminosae).

In cultivating the indigo plant the seed is sown in drills about one foot apart at the beginning of the rainy season. Hoeing and weeding require to be assiduously attended to prevent the plants from being overpowered by weeds. The first crop is obtained in about three months after sowing. The stems are cut as the plants begin to flower, and quickly shoot up again, and in this way two and sometimes three crops are taken from the same plants in one season. Immediately the crop is cut it is tied in bundles and carried to the steeping vats to undergo the process of extracting the indigo; for an account of which see DYEING.

Commercially speaking, indigo may be said to be the produce of India and Central America, as these are the only localities which supply the recognised form of the article. Bengal is the chief seat of indigo produce; and Bengal indigo is the most esteemed. From 1740 till the civil war indigo was much grown in Georgia and South Carolina, but thereafter the United States depended on imported indigo. British imports fluctuated from above 1,000,000 cwt. (value £2,500,000) to under 60,000 cwt. (value £950,000) in the last years of the 19th century, when the trade was menaced by German artificial indigo. The essential constituent of natural indigo is *Indigotin* or *Indigo Blue* (C₁₆H₈N₂O), but it likewise contains *Indigo Brown*, *Indigo Red*, and other ingredients. In 1878 Baeyer of Munich announced the successful synthesis of an artificial indigo from phenylacetic acid, a coal-tar product; and Nenmann of Zurich made the synthesis commercially practicable. By 1897 Germany supplied its own wants from this source; by 1901 one company at Ludwigshafen produced as much as could be grown on 230,000 acres of Indian land, and it was a question whether the growers of natural indigo in Behar and other parts of Bengal would be able to compete with the German aniline companies (see ANILINE, DYEING, SYNTHESIS). The costly so-called *green indigo* of China, used by Chinese artists and for silk-dyeing, is obtained from a tree called *hau-li*.

Indigo Bird (*Cyanospiza cyanea*), a North American bird of the Finch family (Fringillidae), a native of the United States, as far north as the Missouri, which it visits in summer, and of Central America, where it spends the winter. It is about 5½ inches in length, of a beautiful blue colour, variously tinged and shaded. It frequents open places on the edges of woods, and has a very sweet song.

Indium, a metal (trivalent; atom. wt. = 113.1), soft, silver-white, malleable, soluble in hydrochloric acid; its sulphate forms alums with alkaline sulphates. It was discovered in 1863 by Reich and Richter in Freiberg zinc-blende, through observing in its spectrum two characteristic indigo-blue lines.

Individualism. See SOCIALISM.

Indo-China, the eastern of the two great Asiatic peninsulas which extend southwards into the Indian Ocean, sometimes called Further India. It is washed on the east by the Gulfs of Tonquin and Siam and the Chinese Sea, and on the west by the Bay of Bengal. Accounts

of the various states which it embraces will be found under the headings ANNAM, BURMA (with map), CAMBODIA, COCHIN-CHINA, MALACCA, SIAM, and TONQUIN.—The term *Indonesia* is sometimes used for the Indian Archipelago, the islands to the south-east of Asia.

Indo-Europeans. See **ABYAN.**

Indore, a Malhatta principality of India, comprising the territories of the Holkar dynasty, and consisting of several detached tracts, covers an area of 8400 sq. m. The bulk of it lies between Sindhia's dominions on the north and Bombay Presidency on the south, its length from north to south being 120 miles, and its breadth 82. It is traversed from east to west by the Nerbudda, which almost bisects it; by the Vindhya Mountains, their loftiest point within its limits being 2500 feet above the sea; and by the Satpura Mountains. Principal products, poppy, cotton, tobacco, wheat, rice, millets, &c.; principal industries, cotton and opium manufacture. Pop. (1891) 1,099,990. The Vindhya and Satpuras have from time immemorial been the home of the Bhils (q.v.), the wildest of the aboriginal tribes in India. The Holkar State Railway connects the Rajputana railway-system with that of Bombay. The climate is sultry, the thermometer ranging from 60° to 90° F. in the shade. The state was founded about the middle of the 18th century by Malhar Rao, a soldier of fortune, who served the Peshwa. In 1818 the ruler of the Holkar dominions was reduced to the position of a feudatory prince of the British Indian empire. He keeps up an army of 8000 men.

Indore, the capital of the Maharaja Holkar's dominions, is situated in 22° 42' N. lat. and 75° 54' E. long., 1786 feet above sea-level. Pop. (1891) 92,329, mostly Hindus. During the revolt of 1857, though the maharaja remained faithful to the British government, his troops mutinied on 1st July, holding their prince a prisoner in his own palace, and butchering many Europeans in cold blood. The town dates only from 1770. Close to the town is the district specially set apart for the residence of the Governor-general of India's agent for Central India. Within this district stands a celebrated European hospital.

Indorsement, the term generally used to denote the writing of the name of the holder on the back of a bill of exchange or promissory note, on transferring or assigning it to another. Signing the name 'A. B.' alone is a blank indorsement; and if the transferee is named it is an indorsement 'in special' or 'in full.' The usual form is 'Pay C. D. or order. (Signed) A. B.' In Scotland it is 'Pay the contents to C. D. or order. (Signed) A. B.' When personal liability is to be avoided the words 'without recourse' are added, and in this case no demand can come back on the indorser, who would otherwise be liable. The word indorsement is also frequently used in English law to denote any matters written or indorsed on the back of writs or deeds, as indorsements on declarations, on writs of summons, &c.

Indra, the name of one of those Hindu deities that were worshipped more especially in the Vedic period of the Hindu religion, but enjoyed a great legendary popularity also in the Epic and Puranic periods. In these Rig Veda hymns which form the oldest portion of Vedic poetry Indra is a mighty ruler of the bright firmament, and his principal feat is that of conquering the demon *Vritra*, a symbolical personification of the cloud which obstructs the clearness of the sky and withholds the fructifying rain from the earth. All his wonderful deeds are performed by him merely for the benefit of the good, which, in the language of

the Veda, means the pious men who worship him in their songs, and invigorate him with the offerings of the juice of the Soma plant. He is therefore the 'lord of the virtues,' and the 'discomfiter of those who neglect religious rites,' and at the same time he has all the attributes of a warlike god, and is invoked as the destroyer of cities. During the Epic and Puranic periods, where ethical conceptions of the divine powers prevail over ideas based on elementary impressions, Indra ceases to enjoy the worship he had acquired at the Vedic time, and his existence is chiefly upheld by the poets, who, in their turn, however, work it out in the most fantastic detail. A remarkable trait in this legendary life of Indra is the series of his conflicts with Krishna, an incarnation of Vishnu, which end, however, in his becoming reconciled with the more important god. When represented in works of art Indra is generally seen riding on his elephant; and where he is painted he is covered with eyes.

Indre, a department of France, formed principally out of the western portion of the old province of Berry, lies immediately south of the department of Loir-et-Cher. Area, 2623 sq. m., of which about four-fifths are in tillage and pasture. Pop. (1872) 277,693; (1886) 296,147; (1891) 292,868. It is quite flat, and well watered by the Indre (which flows, from the department of Creuse, 152 miles north-westward to the Loire) and the Creuse. It contains three well-marked districts—a stony, woody region with sandy soil in the south, a fertile agricultural region in the east, and in the north-west a region of moors, marshes, and ponds, interspersed with forests. The more notable products are wheat, oats, potatoes, turnips, fruits, and wine. The sheep are excellent as food, and produce first-rate wool. Much poultry is reared. The principal industries are ironworks and manufactures of cloth, paper, leather, and porcelain. The department is divided into four arrondissements—Châteauroux, Le Blanc, Issoudun, and La Châtre. The capital is Châteauroux.

Indre-et-Loire, a department of France, formed chiefly out of the ancient province of Touraine, is crossed by the Loire from N.E. to S.W. Area, 2360 sq. m.; pop. (1872) 317,027; (1886) 340,921; (1891) 337,298. It is watered by the Loire and its tributaries, the Cher, Indre, and Vienne, all of them navigable. The valley of the Loire is very fertile, studded with orchards and gardens and vineyards; it is called the 'garden of France.' South of this lies the monotonous but productive plateau of St Maure, north of it the sterile region of Gâtine. The products include grain, wine (about 22,000,000 gallons annually), fruits (especially plums), and hemp. The industry has never recovered from the blow struck by the Edict of Nantes. The chief manufactures are powder, files, cloth, paper, and leather. The department is divided into the three arrondissements of Tours, Chinon, and Loches; capital, Tours.

Induction, one of the great processes of scientific discovery and proof. It is the operation of *discovering* and *proving* general propositions; while deduction, on the other hand, is the method of *applying* general propositions once discovered to particular cases considered to be included within their scope. By induction we establish the law that heat expands bodies; by deduction we apply it to explain why a clock goes slower in summer than in winter, owing to the changes of the length of the pendulum. It should be mentioned that what has been called *perfect* induction—the observation of *all* the instances and a statement of the result in one general proposition—is not by Mill or the moderns recognised as proper induction at all.

Induction is the process of real inference in other words, by it we proceed from the known to the unknown; or from a limited range of facts we affirm what will hold in an unlimited range. All things that we do not know by actual trial or ocular demonstration we know by an inductive operation. Deduction is not real inference in this sense, since the general proposition already covers the case that we apply it to; in a proper deduction the conclusion is more limited than the premises. By the inductive method we obtain a conclusion much larger than the premises; we adventure into the sphere of the unknown, and pronounce upon what we have not yet seen. Nothing is more common than the making of bad inductions, and accordingly it is now considered a part of logic to lay down the rules for the right performance of this great operation. For the principles and rules of induction, see Mill's *Logic* (book iii.), Fowler's *Inductive Logic*, and Venn's *Principles of Empirical or Inductive Logic* (1890); and see the article LOGIC.

Induction is a term used in England to denote the investing or giving possession of a benefice to a clergyman. This is done by a mandate from the bishop to the archdeacon (in some places the dean and chapter) to make the induction. The inductor takes the clergyman by the hand, and lays it on the key of the church-door (or some part of the church itself), then opens the door and causes him to enter the church alone, and to toll one of the bells as a public notification to the parishioners. The incumbent's possession of the benefice is completed by 'reading himself in'—i.e. reading, generally on the following Sunday, the Thirty-nine Articles, and immediately thereafter making a formal declaration of assent to their doctrine, and giving a pledge of his conformity to the rules of the church.—In Scotland the presbytery inducts the minister.

Induction, in Electricity and Magnetism, is a term of various application. In every case, however, there is a certain idea present—the idea, namely, of an effect produced at an apparent distance from the producing cause, the effect being essentially a reproduction of the cause. More accurately stated, induction is the name of a method or mode by or in which a particular electric or magnetic condition is made to pass from one material system to another without the intervention of any obvious material connection. Thus, in static electricity a metallic body or other conductor brought into the neighbourhood of an electrified body becomes itself electrified by induction. Similarly, a piece of iron or other magnetisable metal, when brought near a magnet, or, more generally, when brought into a magnetic field, becomes itself magnetised by induction. Indeed, according to Faraday's view, induction is the essential feature in all electric and magnetic interaction. These two fundamental cases of induction will be found treated in full under ELECTRICITY and MAGNETISM.

There is, however, a third and very important group of electric and magnetic phenomena to which the name induction belongs. These were discovered by Faraday, and will be treated in a general way under MAGNETISM. The essential peculiarity of this class of induction phenomena is the production of electric currents in conductors or circuits in which there exists no source of electrical energy. These induced electric currents are in all cases the result of some magnetic change in the region occupied by the conductor. This magnetic change may be produced by the approach or withdrawal of a magnet; or it may be produced by the motion of the conductor in a constant

magnetic field; or it may be due to variations of primary currents in neighbouring conductors, or even in the conductor itself. In this last case the variations of these primary currents cause corresponding variations in the magnetic fields existing with them, so that the induced current can always be explained in terms of a magnetic change. According to Ohm's Law (see ELECTRICITY), the strength of a current flowing through a given circuit depends on the electromotive force which excites the current, and on the resistance of the circuit through which the current is made to flow. In the case of induction of currents the electromotive force is directly due, and is measured in terms of, the rate of change of the number of lines of magnetic force embraced by the circuit; and this rate of change depends on the geometrical form of the circuit and on its space relations to the magnetic field surrounding it. Thus the induced current depends on three things—viz. the form of the circuit, the varying space relations of the circuit and the magnetic field, and the ordinary ohmic resistance of the circuit.

One of the readiest ways of producing induced currents is to have two coils of wire, one placed inside the other, and to pass through the inner or *primary* coil a current of varying strength. At every variation of the primary current a current is induced in the outer or *secondary* circuit. The direction of the secondary current depends on the manner of change of the primary. If the primary current is decreasing in strength, the induced current in the secondary circuit flows in the same direction as the primary in its circuit; but if the primary current is increasing, the secondary current flows in the reverse direction. The best effects are produced at the 'making' and the 'breaking' of the primary circuit; for by these operations the primary current is made to have its greatest variations. This is the principle of action of the *Rohmkoff Induction Coil*, one of the many forms of which is shown in the figure. The coils are wound, the primary inside the secondary, on the

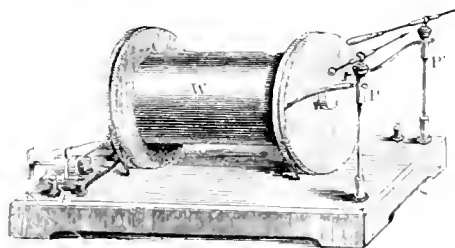

portion marked W. The battery wires, attached to the binding screws, *p, n*, are brought into connection with the terminals of the primary coil by means of the commutator, C. The terminals of the secondary coil are fixed to the brass heads of the glass pillars, P, P, which are furnished with pointed rods capable of universal motion. The true way of looking at the action of this instrument is to regard the primary current as the source of a magnetic field within and around the coils. To intensify the magnetic field it is usual to introduce a soft iron core into the centre of the coils. In virtue of magnetic induction this iron core, under the influence of the magnetic force due to the primary current, becomes powerfully magnetised, and the magnetic field within the coil greatly increased. When the primary current is interrupted the iron core loses nearly all its magnetism, and accompanying this great decrease in the strength of the magnetic field an intense induced current flows in the secondary circuit. Now

it is only when the magnetic field is varying that the induced electromotive force exists; and, since in a given secondary circuit the total current induced is proportional to the total change in the magnetic field, it follows that the more abrupt this change the more concentrated will be the flow of the secondary current.

In the induction coil matters are so arranged that the induced current is sufficiently concentrated to pass across a considerable air-space, which really forms part of the secondary circuit. By taking the terminals of the secondary circuit in our hands we may make ourselves part of this circuit, and experience the curious throbbing sensation of a galvanic shock. Or we may attach the terminals to the platinum wires of a Geissler tube, and produce the beautiful effects of electric discharge through gases in a state of great rarity. In most forms of induction coil the primary current is broken and made automatically, the varying magnetic strength of the iron core being used for this purpose. When the primary current passes, the iron core becomes a powerful magnet, and attracts a small iron disc set opposite one end. By means of a simple form of lever attachment this disc when so moved interrupts the primary circuit. The current then ceases to flow, the iron core loses most of its magnetism, and the small iron disc thus freed returns to its original position. With this return of the disc the primary circuit is again completed, the current flows as before, and the same order of effects is repeated, and so on indefinitely. In the secondary coil there is, of course, a possible induced current at make as well as at break. But, as in such instruments the corresponding magnetic change is not nearly so rapid at make as at break, the induced current is not so concentrated. Hence, practically, in working with an induction coil we have to do only with the induced current due to the interruption of the primary circuit.

The Telephone (q.v.) is an instrument whose action depends largely upon the laws of electro-magnetic induction; and in the same category we may include the induction balance of Professor Hughes, which illustrates in a marvellous way the sensitiveness of a variable current flowing in a circuit to the presence of a small piece of metal or other conducting material.

Indulgence, in Roman Catholic theology, means a remission, by church authority, to a repentant sinner of the *temporal* punishment which, in the Catholic theory, remains due after the sin and its eternal punishment have been remitted. By the discipline of the first centuries a severe course of penitential observance was exacted of all who fell into any grievous crime, especially apostasy, murder, and adultery, such sinners being excluded from church communion for various periods, in some cases even till the hour of death. These penitential observances, which Protestants regard as purely disciplinary, were designed, according to the Catholic view, as an expiation on the part of the penitent for the *temporal* punishment which, after sin and the *eternal* punishment due to it have been remitted by God, still remains to be undergone; and some of the most acrimonious of the early controversies, the Montanist and the Novatian, arose as to the power of the church to relax these penitential observances, and to admit grievous sinners to communion. These ancient relaxations (of which they regard that referred to in 1 Cor. v. 5 and in 2 Cor. ii. 10 as a type) are considered by Catholics as examples of the modern indulgence; and the practice which grew up in the 3d and 4th centuries, and which even then was carried to great extremes, of granting such relaxations on the

recommendation of martyrs or confessors, is held by Catholic theologians to be an illustration of that principle of vicarious atonement according to which, in the theory of indulgences, the church is supposed to supply from the inexhaustible treasure of the merits of Christ, and of the 'supererogatory' works of the saints, what may be wanting to the completeness of the atonement of the less perfect but yet truly penitent sinner to whom she grants the indulgence. That this practice of relaxation, whatever may have been its real import, was to be used according to the judgment of the bishop as to the disposition of the penitent, is expressly laid down by the Council of Ancyra in 308 and by that of Nice in 325. In all cases, however, the person granting the relaxation was to impose certain good works as a partial substitute for the penalty which had been relaxed; and among these works, which had at first been purely personal, came by degrees to be included money payments for certain religious or charitable objects, as the building of a church or the foundation of a monastery or hospital.

The name indulgence appears to have originated late, the first recorded instance of its use being by Alexander II. in the 11th century; but the institution itself is found in full development during the wars of the Crusades, the serving, or the contributing to service in which, 'provided it were for devotion alone, and not from motives of greed or of glory,' was accepted in the Council of Clermont 'as an equivalent substitute for all penance.' Such an indulgence was called 'plenary;' where a portion only of the penitential works was relaxed it was called 'partial;' and in order to put a bar to their excessive multiplication and to other abuses Innocent III. declared the power of granting 'plenary indulgences' to be reserved to the pope alone, bishops being only authorised to grant the 'partial' or limited indulgences described above. The fourth Lateran council condemns the 'indiscreet and superfluous' granting of indulgences; and among the abuses which grew up in the church during the western schism one of the most remarkable was the lavish dispensation of indulgences, in the granting of which the contending popes rivalled each other in prodigality. The last extreme, however, was not reached until the beginning of the 16th century, when, with a view to raising the funds necessary for the erection of the great church of St Peter's at Rome, the pope, Leo X., published a plenary indulgence, the principal condition for the gaining of which was a contribution to this work. Catholic historians contend that in itself such a condition was perfectly justifiable, and that if duly explained to the people it might be lawfully and even meritoriously complied with; but they admit that Tetzel and many more preachers of the indulgence in extolling its natural effects went to indefensible extremes, and that, even making the fullest allowance for exaggeration, it cannot be denied that grievous abuses both of doctrine and of practice were committed in Germany and in Switzerland. Hence the decree of the Council of Trent, while it affirms that the use of indulgences, as being 'most salutary for the Christian people, and approved by the authority of councils, is to be retained in the church, yet orders that 'in granting them moderation be observed, lest by excessive facility discipline may be enervated.' Upon the special instructions of this council all the modern legislation on the subject of indulgences has been founded; but as the decree of the council does not explicitly declare what is the precise effect of an indulgence it is further explained by Pope Pius VI., in his celebrated bull *Auctorem Fidei*, that an indulgence received with due dispositions remits not alone the canonical

penance attached to certain crimes in this life, but also the temporal punishment which would await the penitent after death to be endured by him in purgatory.

From the above explanation it will be gathered that Catholics do not understand by an indulgence a remission of sin, much less a permission to commit sin or a promise of forgiveness of future sin. They contend, moreover, that, since the benefit of an indulgence can only be enjoyed by a sinner who has repented of sin and resolved to embrace a new life, the imputation of introducing laxity of principle and easy self-indulgence is entirely unwarranted. And although for the most part the good works which are required as the condition of obtaining indulgences may appear easy and even trivial, yet the one indispensable preliminary—sorrow for sin and sincere purpose of amendment—involves the highest effort of Christian virtue.

See vol. iii., H. C. Lea's *History of Auncular Confession and Indulgence* (1896).

THE DECLARATION OF INDULGENCE, proclaimed by James II. in 1687, promised to suspend all laws which tended to force the consciences of his subjects. His real aim was, of course, merely to relieve the Roman Catholics; hence the declaration was very unpopular, and the refusal of the Seven Bishops to command their clergy to read it from their pulpits was but the culminating point of universal public dissatisfaction. Two similar indulgences in English history were those issued by Charles II. in 1662 and 1672, both of which were equally displeasing to the dissenters alike in England and Scotland, who declined to share their toleration with their Roman Catholic fellow-subjects.

Indus (Sansk. *Sindhu*), a river of India, which rises in an unexplored region in Tibet, near the sources of the Sutlej, in 32° N. lat. and 81° E. long. The precise spot is said to be 16,000 feet above the level of the sea, and to be on the north side of the Kailas Mountain. Its general course is at first towards the north-west, through Tibet and Cashmere. Here it is known as the Singh-ka-bab. In the north-west of Cashmere, in about 34° 50' N. lat. and 74° 30' E. long., it turns abruptly southwards, and follows that direction, varied by stretches to the south-south-west, right down to the sea. In the mountains its current is very rapid; the river passes through deep, wild gorges (one near Iskardoh, in north-west Cashmere, having a sheer depth of considerably more than 10,000 feet), and is liable to floods, which come with terrible swiftness, rise very high, and cause tremendous damage. The Indus enters the Punjab 812 miles from its source. Near Attock (q.v.), 48 miles lower down, it receives the Kabul River from Afghanistan, and then becomes navigable. Here it is only 2000 feet above sea-level. 150 miles below Attock it receives, on the left, the accumulated waters of the Punjab through the single channel of the Panjnad. Each of the five water-courses, as well as the Kabul, is practicable for inland craft to the mountains. Below its confluence with the Panjnad the Indus, instead of increasing in volume, becomes gradually less. Its basin is narrow, and the affluents are insignificant, while there is a great loss by evaporation. The river also divides into numerous channels, many of which become lost in the sand, while others return much shrunken in volume. The delta of the river covers an area of about 3000 sq. m., and extends for some 125 miles along the Arabian Sea. The main channel is constantly shifting. The delta is not on the whole very fertile, and is almost entirely destitute of trees. In both Punjab and Sindh the bed of the river is littered with islands and sandbanks. The cultivation of the arid plains

through which the lower Indus passes is dependent upon the annual overflow of the river and artificial irrigation fed by that overflow. The total length of the river is estimated at somewhat more than 1800 miles, and the area of its drainage basin at 372,700 sq. m. The Indus abounds with fish of excellent quality, and is infested by crocodiles. Before the opening of the Indus Valley Railway in 1878 the river was necessarily the principal means for the transmission of commerce; but since that event the railway has very greatly superseded navigation.

Industrial Schools. This term is used very variously, sometimes being synonymous with Ragged Schools, in which mechanical arts are taught; sometimes designating ordinary elementary schools, in which agricultural or some other industrial art is taught to the boys during one portion of the school-day, or in which sewing, cooking, washing, and ironing are taught to the girls. See EDUCATION, TECHNICAL EDUCATION, RAGGED SCHOOLS.

Inebriates. **RETREATS FOR.** The Habitual Drunkards Act, 1879, amended and made permanent by the Inebriates Act, 1888, made provision for the licensing of institutions for the reception and treatment of habitual drunkards. By these acts an inebriate might sign a bond before two justices of the peace for a period not exceeding twelve months, under which the licensee of the retreat had power to detain and control him during the time specified. No provision was made for the committal of any one against his will, nor for the establishment of retreats for the reception of persons unable to pay for their maintenance. The Inebriates Act of 1898, which came into force on 1st January 1899, gives power to courts of justice to commit persons convicted of penal offences whose offence may be traced to drink, or who may be found to be habitual drunkards, to three years' detention in a state (or certified) inebriate reformatory. The Secretary of State is empowered to establish state inebriate reformatories, or, on application from county or borough councils or private persons, to certify private inebriate reformatories. Full provision is made for the conducting and management of these institutions. The act applies to the whole United Kingdom. An amending act (1899) provides for the payment of expenses of prosecutions under the act.

In America there were in 1895 above fifty such hospitals, with over 1000 patients. In some states of the Union, inebriates may be compulsorily committed to these institutions. It is claimed that 'in fully 3000 cases, 35 per cent. of those who had remained under treatment at least one year had been permanently restored.'

Inertia (Lat., 'inactivity'), a universal property of matter, fully described in Newton's first law of motion, which asserts that *every body perseveres in its state of rest or of uniform motion in a straight line except in so far as it is compelled by force to alter that state*. Part of this principle was known to the ancients, and by them attributed to a certain repugnance to motion, which was a characteristic of all matter; but it was shown by Galileo that just as the body at rest could not of itself begin to move, so the body in motion could not of itself come to rest.—The *Moment of Inertia* is the sum of the products of every particle of a mass into the corresponding distance from a given point or axis of rotation.

Ines de Castro. See CASTRO.

Infallibility, the immunity from error, in all that regards faith and morals, which is claimed by the Roman Catholic Church, and, at least as regards the past, by the Greek Church, as represented in the decrees of the

councils which that church looks upon as œumenical. The latter claim, however, which does not go beyond that of *inerrancy*, or actual exemption from error up to the present time, differs widely from that of infallibility, as put forward by the Roman Church, which involves not alone an actual historical immunity from error, but also such a positive and aiding assistance of the Spirit of God as will at all times both protect against the possibility of error and guide and direct in the faithful teaching of all necessary truth. The infallibility claimed by the Roman Church is thus of two kinds, *passive* and *active*—the first (Matt. xvi. 18), in virtue of which the church never can receive or embrace any erroneous doctrine, no matter by whom proposed; the second, in virtue of which she is charged with the function (Matt. xxviii. 19; Mark, xvi. 15; Ephes. iv. 11-16) of permanently *teaching* to the world the essential truths of God, of actively resisting every access of error, and of authoritatively deciding every controversy by which the oneness of belief among the faithful may be endangered. Catholics regard this gift as a natural and necessary accompaniment of the authority in matters of faith with which they believe the church to be invested, and which, if not guided in its exercise by such infallible assistance, would be but a false light and an attractive but dangerous instrument of delusion.

Such is the notion of infallibility as claimed by the Roman Church. Two very important and practical questions, however, arise regarding it, both of which have been the occasion of much controversy even among Catholics themselves: (1) as to the *subject*—the seat or the organ of this infallibility, and (2) as to the *object*—the matters to which it extends.

As to the first, all Catholics have been agreed that the body of bishops, morally speaking, throughout the church, acting in common with the pope, constitute the most perfect organ of the infallibility of the church; and hence, that when they unite in any way, whether assembled in a general council or separated in place, their judgment is infallible. Thus, if a doctrinal decree was addressed officially by the pope to the whole church, and either expressly confirmed or tacitly accepted by the bishops, this decree was held to be infallible. In like manner, if a doctrinal decree, emanating even from a local council, as that of a national, or even a provincial church, was universally accepted by the pope and the bishops, that decree also was held to be infallible. In a word, wherever there is found the *united* judgment of the pope and the bishops, all have agreed in accepting it as the infallible judgment of the church. But should the pope alone judge without the bishops, then arose the well-known dispute of the Gallican and Ultramontane divines; the latter affirming, the former denying, the papal judgment to be infallible; but all agreeing that it was not binding *as an article of Catholic faith* so long as it had not received the assent of the body of the bishops. By the decree of the Vatican Council (1870) this controversy was decided after much dissension; the constitution *Pastor Æternus* teaches 'that when the Roman Pontiff speaks *ex cathedra*—that is, when he, using his office as pastor and doctor of all Christians, in virtue of his apostolic office defines a doctrine of faith and morals to be held by the whole church—he by the divine assistance, promised to him in the blessed Peter, possesses that infallibility with which the Divine Redeemer was pleased to invest his church in the definition of doctrine on faith or morals, and that therefore such definitions of the Roman Pontiff are irreformable in their own nature and not because of the consent of the church.' See PORE.

On the matters or subjects to which the gift of infallibility extends Catholics are agreed in one principle, that it embraces all those subjects, and those only, which are necessary for the maintenance of divine truth in the church. Hence, presupposing divine revelation, either written or oral, it embraces all questions of faith and morality, all subjects of general discipline, so far at least as to preclude the introduction, by authority of the church, of any discipline which should be injurious to faith or to morality. On the other hand, it does not embrace questions of science, or matters of fact, or abstract opinions unconnected with religion. On this point all Catholics have been agreed. But a very celebrated dispute arose in the 17th century, on occasion of the *Augustinus* of Jansenius, as to the infallibility of the church in judging of books, out of which originated the well-known Jansenist distinction of *law* and of *fact* (see JANSENISM). On this subject it will be enough to say that all Catholics are now agreed in recognising as a necessary condition to the effective infallibility that it should extend to the judgments upon books so far as to decide whether the doctrine contained therein may or may not be opposed to sound faith or morality.

[The Vatican Council produced a large literature, including Cecconi, *Storia del Concilio Vaticano* (1873); Frond, *Actes et Histoire du Concile Œcumenique de Rome* (8 vols. 1870-73). Salmon's *Infallibility of the Church* (1889) discusses the doctrine controversially from the Protestant point of view.] See also BASEL (COUNCIL OF), POPE, ROMAN CATHOLIC CHURCH, &c., and Rev. D. Lyons, *Christianity and Infallibility—Both or Neither* (1892).

Infamy, in law, was a stigma attaching to the character of a person so as to disqualify him from being a witness. It was distinguished into infamy of fact and infamy of law. Infamy of fact results from a depraved course of life and abandoned character, of law from the sentence of a court finding the person guilty of any crime to which the character of infamy attached. Since 1843 it has not been possible to exclude a witness on the ground of infamy, though questions as to character and as to crimes committed by a witness may be asked with a view of affecting his credibility.

Infant, in English law, is a term which includes all persons under the age of twenty-one. Such persons are subject to special rules of law, which may be summarised as follows:

(1) *Crime*.—A child under seven cannot be convicted of crime; a child between seven and fourteen can be convicted if it is shown that he knew the nature of his act. A boy under fourteen is presumed incapable of rape.

(2) *Marriage*.—Boys under fourteen and girls under twelve cannot contract marriage. As a general rule, infants of marriageable age require the consent of parents or guardians to marry; but the absence of such consent does not affect the validity of a marriage actually solemnised. A person procuring the marriage of an infant by fraud forfeits any property which accrues to him or her from the marriage.

(3) *Property and Contract*.—An infant may acquire and dispose of property, enter into contracts, and carry on business; but he is privileged to repudiate liability for his acts, except in certain cases. Contracts for necessaries (i.e. for things suitable to the infant's position in life) are binding on him; and settlements, &c., executed with the approval of a judge, in terms of certain acts of parliament, are also binding. On coming of age an infant may confirm or rescind any act by which he has acquired or disposed of property during infancy; if he continues to hold property acquired, he must perform obligations connected with it; if e.g. he has acquired shares in a company, he must

pay calls on them. If he has entered into a continuing contract (e.g. a contract of partnership), he is taken to have confirmed it, unless he rescinds and ceases to take the benefit of it within a reasonable time. As for his other contracts, he might formerly have confirmed them by an *express* ratification; he is now precluded from doing so by the Infants' Relief Act of 1874, which enacts that no action shall be brought on the ratification of a promise made during infancy. No will made by a person under twenty-one is valid. An infant may bring an action by his *prochein ami* or next friend (usually his father, if living). If an action is brought against him, a guardian *ad litem* may be appointed. A parent or guardian is not liable for the debts of an infant, unless he has expressly or by implication contracted to pay them. An infant may contract as agent for a person of full age; in this case his acts are regarded as the acts of his principal.

In Scotland the law differs in many respects from the law of England on this subject. The term infant is not used at all in a technical sense. All persons, if male, are in legal strictness called pupils till fourteen, and if female, till twelve; and from fourteen or twelve to twenty-one they are technically called *minors*. In general, the contracts of a pupil are absolutely void, and he is under the care of tutors, who are either his parents or others appointed by the court. A minor, on the other hand, may enter into contracts; but if they are to his lesion or prejudice he can reduce or set them aside any time within four years after majority. Moreover, if a minor go into trade, his contracts bind him, as they do other persons. Further, a minor can make a will or testament, operating on his movable estate, though he cannot alienate his heritable estate in like manner. The four years which are allowed to him after majority to consider whether he will set aside contracts are called *quadrimum abile*; and if he can prove lesion he is in that period entitled to restitution. In Scotland, also, a minor may marry as freely as if he were a major, and, indeed, he is in general his own master, or *sui juris*, at the age of fourteen (a female at twelve). See the article AGE.

Infant, FEEDING OF. When the health and strength of the mother admit of it, there is no doubt that the food provided by nature is far the best suited for infant nourishment. In this case the child should be fed entirely on breast milk for the first six or eight months at least, and partially for the remainder of the first year of life. Beyond this period, nursing is usually injurious to mother and child, but is often continued because of the idea that it tends to prevent pregnancy. If from any cause the mother is unable to nurse her infant, a wet-nurse is the best substitute; though the improvement effected in the preparation of artificial foods has rendered this method of bringing up infants less common than it used to be. The selection of a suitable nurse should be entrusted to the medical adviser, and is a responsible and difficult duty. When neither of these methods is available, the milk of some animal has to be used. Goats' milk and asses' milk have both been recommended, as more nearly resembling human milk than cows' milk does; but, as they are almost always difficult to procure, while cows' milk is abundant and cheap, it is this which in the vast majority of cases must be employed. The differences between human milk and cows' milk must therefore be recognised and allowed for. They may be summed up as follows: Cows' milk contains much less sugar, rather less fat, and considerably more albuminoids than human milk; and under the action of acids a much larger proportion of albuminoids coagulate, and form a much firmer

clot in the former than in the latter. To assimilate cows' milk as closely as possible to the natural food of the infant, it must be modified in some such way as the following: One tablespoonful of milk to be mixed with half a tablespoonful of cream, two tablespoonfuls of water (boiled), and a quarter of a teaspoonful of milk sugar for each meal during the first month. If the cows' milk still forms too firm a clot, a tablespoonful of lime water, or of barley water, may be substituted for one tablespoonful of plain water; or a little solution of gelatine, or of one of the prepared foods for infants, such as Mellin's, may be added. The quantity of milk, &c. must be gradually increased as the child grows, till at the sixth month it has nine tablespoonfuls of milk, one of cream, two of water, and a teaspoonful of milk sugar at each meal. It is sometimes, but not generally, necessary to secure a supply of milk from one cow. If ordinary milk disagrees, predigestion (by Fenger's liquor pancreaticus or Fainchild's peptonising powder) may overcome the difficulty. If milk cannot be borne in any form, some substitute (prepared 'infants' food, chicken broth, raw meat juice, &c.) must be used. But in all such difficult cases, medical advice should be sought.

There is no more fruitful source of illness in infants brought up on the bottle than imperfect attention to cleanliness, which leads to souring of the milk and severe indigestion. There should always be at least two bottles, tubes, &c. in use; and after a meal the apparatus should at once be taken to pieces, thoroughly cleansed with soda and water, and left steeping in fresh boiled water till it is required. No cork, wood, or other absorbent substance should be used in the construction of the fittings of the bottle, as this renders perfect cleanliness almost impossible.

Till after the sixth month at least the infant is unable to digest starchy foods, unless specially prepared as in the 'infants' food'; and the giving of rusks, biscuit-crumbs, &c. before this period cannot be too strongly condemned.

It is no less important to the infant than to the adult, but rather more, that the meals should be taken regularly. During the first six weeks, whatever method of feeding is adopted, a meal should be given on the average every two hours from 5 A.M. to 11 P.M. From this period to the eighth month the interval should gradually be increased to three or four hours, and always as far as possible the time of the meals should be the same from day to day. Of course these are merely general statements; the contentedness and thriving of the infant are the true guides in each individual case. To give it a meal every time it cries merely overloads the stomach and provokes disorder of the digestion.

After the eighth month five meals a day should be enough, and two should consist of farinaceous food, well cooked (rusks, stale bread crumbs, oat, barley, or wheat flour), as well as milk. About the tenth month the yolk of an egg may be given once or twice a day, or chicken soup in its stead. After the first year the range of the diet may be gradually increased, bread, mashed potato, meat broth, fish, chicken, well-boiled vegetables being gradually added. But many children thrive well on milk and farinaceous food alone up to two or three years of age, and if so may be allowed to continue on that diet.

Infante (from the Lat. *infans*, 'an infant'), the title given in Spain and Portugal to the princes of the royal family, the corresponding title of INFANTA being given to the princesses. Since 1388, however, the heir-apparent to the throne in Spain has been styled the Prince of Asturias, and the heir-apparent in Portugal, until the separation of Brazil from the mother country, bore the title

of Prince of Brazil. The personal domain of an Infante or Infanta is called the *Infantado*.

Infanticide, or the murdering of infants, was common in ancient times, and still prevails in some barbarous communities. The practice existed in Greece and Rome, and even found defenders in Plato and Aristotle. The latter in his *Politics* said the law should forbid the murturing of the maimed, and, where a check to population is required, abortion should be produced before the quickening of the infant. In Sparta, as in other Greek states, the law directed that when a child was born the father should carry it to an appointed place, there to be inspected by the elders of the community. If it was a promising child, they returned it to its parents to be educated; otherwise it was thrown into a cavern at the foot of Mount Taygetus. In ancient Rome the Twelve Tables directed malformed infants to be immediately destroyed, and by the *Patria Potestas* the father had an absolute power over his children extending to life and death; but the rigour of the paternal law both as regards the killing and the sale of infants was softened by subsequent legislation, and especially by Numa. Among the Norse the child's life hung in the balance till the father handed it to the nurse to be reared. If it was weak or malformed, or if the father disapproved of its living, the child was killed by exposure to the weather and to wild beasts. According to Cæsar the Gauls were invested with the power of life and death over their children, and so late as the 13th century the Poles killed imperfect children. Amongst the Arabs it required an ordinance to prevent the crime of killing children lest the parent should be reduced to want, and this element of anxiety for the father's independence and comfort entered largely into the calculations of many states, barbarous and civilised, with regard to their posterity. The Arabs also buried female infants alive.

In modern times infanticide prevails only amongst barbarous or semi-civilised nations, and even amongst these the increased intercourse with civilised states is gradually stamping out the practice. Until comparatively recent times child-murder prevailed throughout the whole of the South Sea Islands. In the Fijian island of Vanna Levu, or some parts of it, the infanticide reached, till the middle of the 19th century, a half and in others two-thirds of the child population. Amongst the Hindus the practice of destroying children, especially females, prevailed to a fearful extent, until it was checked under the Marquis of Wellesley's rule (1798-1805). The practice was forbidden by the Vedas; but, in consequence of the expense and the disgrace attached to girls remaining unmarried, the practice prevailed amongst the Rajputs—who destroyed all females except the first-born—and the native races. The methods of killing were poisoning by pills of tobacco, drowning in milk, smearing the mother's breasts with opium, and plastering the mouth with cow-dung. Notwithstanding the Koran, the Moham medans were inclined to the practice, but effected their object by means of abortion. Efforts began to be made towards the close of the 18th century, amongst others by Jonathan Duncan and Major Walker, for the suppression of the practice, and in 1853 these efforts were at last crowned with success at a dinner arranged for by Lord Lawrence. It was thought expedient to continue a system of surveillance by the police in some districts, and to institute a system of average numbers in families, which concentrated their vigilance upon those families which reached the lowest average. Amongst the Japanese the father had, but has not now, absolute power of life and death over his children. In China infanticide was, and in the

remoter parts of that vast country still is, common. One of the causes here is the right possessed by Chinamen of periodically repudiating their wives. Sometimes the infants were stilled by the midwives at birth, and sometimes they were cast into a neighbouring stream, where in some cases they were humanely kept afloat by a gourd, so that they might be saved from destruction by any compassionate person who might feel disposed. In early missionary times it was a part of the duty of missionaries to pick up and rear, or entrust to others for the purpose of rearing, the waifs who had been abandoned through the avarice, poverty, or callousness of their parents.

In nearly all the cases mentioned infanticide was prompted by religious or economic reasons, or indulged in from caprice or indolence; and it was permitted in deference to the power with which in primitive communities as well as in advanced states like Greece and Rome the father was endowed. Modern civilisation deals very differently with the subject. In all European states, although they differ widely in their treatment of infanticide and cognate crimes, human life is from its first to its last hour held sacred, and whoever puts an end to it is a murderer. Almost the only motive which in such countries now leads to infanticide is that of shame—the parents incurring the risk of committing child-murder to escape social disgrace. The efforts therefore of legislators and criminal lawyers on the one hand have been directed to the repression of abortion, concealment of pregnancy, and murdering the new-born infant, and of philanthropists on the other to remove temptation to commit the graver crimes by providing Foundling Hospitals (q.v.), where the offspring of sin may find a refuge. See also ILLEGITIMACY.

In England and Scotland the inexcusable killing of infants is theoretically murder, and the only excuse for killing the foetus is the safety of the mother; otherwise, Abortion (q.v.) is a criminal offence. The concealment of birth is also a criminal offence; see BIRTH (CONCEALMENT OF). The destruction of children may be effected negatively by not supplying food and clothing, as well as by the positive act of wounding or ill-treating; and if a parent or other person who is bound by law to supply food and clothing to the child refuses or neglects to do so, thereby causing its death, such refusal or neglect amounts either to murder or manslaughter, according to the circumstances. Moreover, the unlawful abandoning or exposure of any child under the age of two years, whereby the life and health of the child are endangered, is a misdemeanour punishable with three years' penal servitude. Where a person is charged with the murder of a very young child it is essential to prove that the child was in life. Under a statute of James I. there were presumptions against the mother, but in 1803 the trials for offences of this class were placed under ordinary rules of evidence. The presumption which now obtains that every new-born child found dead was born dead is believed by certain jurists to have encouraged infanticide. The test of a child being born alive is not that it breathed, or had an independent circulation after it was separated from the mother; it is enough that the child was fully born. Hence, if a man strike a woman with child, so as to cause the death of the child, he is neither guilty of murder nor of manslaughter of the child. In all cases of the murder of infants the question whether the child was fully born, and so the subject of murder, is generally one of medical jurisprudence. In England and Wales the annual number of verdicts of murder of infants one year old and under varied in 1879-88 from 65 to 103. The above offences in reference to infanticide are

punished in a similar manner in Scotland, where, though the killing of a completely born infant is murder, a verdict of culpable homicide is frequently returned. Concealment of pregnancy is the usual charge under 49 Geo. III. chap. 17.

It has been stated that every day an impost is held upon the bodies of children destroyed through the design, the neglect, the ignorance, or the mental infirmity of the mothers. Even when the act may fairly be regarded as a crime, its enormity is generally greatly lessened in the eye of the law by the consideration of the physical condition and moral disturbance of the parent.

An Act of 1872 obliges those who undertake for hire to nurse infants under the age of one year, for a longer period than twenty-four hours, to have their house registered, and to keep records of the children they take charge of. They must also give notice to the coroner or procurator-fiscal of such infants' deaths, and are under obligation to keep sanitary houses. By an important statute passed in 1889 any person over sixteen who wilfully ill-treats, neglects, abandons, or exposes a boy under fourteen or girl under sixteen years of age, or causes or procures this to be done, in a manner likely to cause the child unnecessary suffering or injury to its health, is guilty of a misdemeanour, and is liable to £100 of fine or imprisonment for two years, or to both. Lesser penalties are inflicted on summary conviction. The fine may be increased where the offender is proved to be interested in the death of the child. See CHILDREN (CRUELTY TO), and BURIAL SOCIETIES.

Infantry. See ARMY.

Infant Schools. The subject has been already treated under Education (q.v.). But there still remain a few points to be adverted to. Pastor Oberlin (q.v.) may be regarded as the founder of infant schools. He appointed women in his own parish to assemble the little children between the ages of two and six, to interest them by conversation, pictures, and maps, and to teach them to read and to sew. The first infant school attempted in Great Britain was in connection with Robert Owen's socialistic establishment in Scotland. The education and training of young children were matters of great interest and study to Pestalozzi (q.v.). His system was adapted to English requirements by the Home and Colonial Infant School Society, founded in 1836. This society has done excellent work in training teachers and instituting model infant and juvenile schools. But the most successful system of educating quite young children is the Kindergarten (q.v.).

Infection. The grounds for believing that each of the large class of communicable diseases depends upon the presence within the body of a distinct living organism have already been stated (see GERM). The manner in which each of these supposed organisms behaves in originating fresh cases of disease is, however, almost as characteristic as the effects it produces on the body.

(1) In malarial or miasmatic diseases, chief among which is ague, though they present many analogies to truly infectious diseases, there is no evidence that the malarial can be transmitted from the sick to the healthy. The disease poison is derived from soil, water, or air, in which it seems to live and multiply.

(2) Intermediate between these and the more characteristic infectious diseases is a group of which cholera and typhoid (enteric) fever may be taken as types. Here the infectious material has its origin chiefly from the defects of the patient, but seems to acquire infectious properties only after it has been some time (probably for several days) outside the human body.

(3) The largest and most typical class includes typhus, smallpox, measles, scarlet fever, whooping cough, and many others. In all these the disease is directly and immediately communicable from the sick to the healthy. But there are striking differences in the conditions under which infection usually takes place. The poison of typhus, the dreaded 'jail fever' of past times, is rapidly destroyed by admixture with air, and the danger of its spreading can be much diminished by free ventilation. In smallpox the infection can retain its vitality for years on the walls of a room, or in the artificially dried discharge from the pustules; in scarlet fever it may exist for many months in articles of clothing. Measles is not least infectious in the early stage, when it presents merely the symptoms of a bad cold; scarlet fever infection is not at its worst till the rash has faded and the skin begins to be shed.

(4) The last group consists of those diseases in which the poison does not diffuse itself through the air, but requires to be directly inoculated to produce the disease—e.g. syphilis and hydrophobia.

This classification of diseases believed to be dependent upon organisms, though practically convenient, cannot be considered a strictly accurate one; for many of the diseases in group 3, perhaps all, can be propagated by inoculation, and the infection of some may be able to develop outside the body and behave like those in group 2. Enough has been said to show the complexity of the problems, both practical and scientific, presented by the subject. As to the Infectious Diseases Notification Act of 1889, and other cognate matters, see HYGIENE, DISINFECTANTS, CONTAGION, and the articles on the several diseases.

Infefment, or **SASINE**, a Scotch law term, used to denote the symbolical giving possession of land, which was the completion of the title, the mere conveyance not being enough. The instrument of sasine was the notarial instrument embodying the fact of infefment. The old ceremony, which was not abolished until 1845, was thus performed. The baillie of the superior of the lands, the attorney of the vassal, a notary, and two witnesses proceeded to the lands in which sasine was to be granted. The attorney delivered to the baillie the superior's precept of sasine, and required him to perform his duties. The baillie delivered the warrant and relative deeds to the notary, who read and published them to all present. The baillie thereupon delivered the symbols of possession, sometimes a pen, to the attorney, and the attorney then took instruments in the hands of the notary by giving him a piece of money. But now the necessity of a separate formality is unnecessary, it being sufficient to register a conveyance in the register of sasines in Scotland. In Scotland an *infefment in security* is a temporary infefment to secure payment of some debt; and an *infefment of relief* is a similar security to relieve a cautioner.

Inferral Machines, contrivances made to resemble ordinary harmless objects, but charged with some dangerous explosive. An innocent-looking box or similar receptacle is partly filled with dynamite or other explosive, the rest of the space being occupied by some mechanical arrangement, mostly clockwork, which moves mandibly, and is generally so contrived that, when it has run down at the end of a predetermined number of hours or days, it shall cause the explosive substance to explode. For a statement of the uses to which this class of inferral machines has been put by the anarchist parties, see DYNAMITE. Fire-ships (q.v.) were employed in former times; and modern nations apply a similar principle in their torpedo boats (see TORPEDOES). Bombs or hand grenades,

in so far as they have been employed for the felonious destruction of human life, must also be accounted infernal machines. The most notorious instances have been the unsuccessful attempt on Napoleon III. by Orsini (q.v.) in 1858 and the killing of Alexander II. of Russia in 1881. See also CHICAGO, ANARCHISTS.

Infidel, amongst Christians, popularly means one who rejects Christianity as a divine revelation, but is not used of heathens (though they are *infideles*, Lat. 'unfaithful') or heretics. By Moslems Christians are called by a corresponding term ('*giaour*,' '*kafir*,' &c.). See ATHEISM, DEISM, APOLOGETICS, CHRISTIANITY, HERESY, PERSECUTION.

Infinite. In philosophy, infinite is that which is without any limitation, and, like absolute and unconditional, is used especially of the Infinite, of God. As to our knowledge of the infinite, some (as Hamilton and Mansel) hold that the idea is purely negative; Descartes affirmed that the idea of the infinite was not merely the idea of an objective reality, but is implied as a necessary condition of every other. See ABSOLUTE, CONDITION, RELATIVITY OF KNOWLEDGE; Hamilton's *Discussions*, Mansel's *Limits*, Calderwood's *Philosophy of the Infinite*, Spencer's *First Principles*.

In mathematics, the term infinity and the phrases infinitely great and infinitely small are of constant occurrence; and the symbol ∞ is usually said to denote a magnitude infinitely great, the symbol 0 a magnitude infinitely small. Are these magnitudes infinitely great and infinitely small to be reasoned about in the same way as ordinary finite magnitudes? Are these symbols ∞ and 0 to be treated in the same way as ordinary algebraic symbols, a , b , x , y , &c.? With respect to the symbol 0 there seems at first sight to be little difficulty, for we are accustomed to regard it as denoting the absence of all quantity, or as the result obtained by subtracting any finite quantity from a quantity equal to it. It is found convenient however, though it would be impossible to explain in short compass the grounds of the convenience, to give another meaning to the symbol 0. The new meaning will perhaps be understood from the following illustration. Take the algebraical expression $\frac{1}{x}$, and suppose x capable of increasing so that it may become greater than any assignable quantity; then the value of $\frac{1}{x}$ will diminish and become less than any assignable quantity, and the limit towards which it tends, that is to say, the value from which it may be made to differ as little as we please, is symbolised by 0. The same expression will enable us to give a meaning to the symbol ∞ . Suppose x capable of diminishing so that it may become less than any assignable quantity; then the value of $\frac{1}{x}$ will increase and become greater than any assignable quantity, and the limit towards which it tends, that is to say, the value from which it may be made to differ as little as we please, is symbolised by ∞ . The symbols 0 and ∞ therefore, denoting the limits towards which certain variable quantities tend when particular suppositions are made, cannot be used absolutely like the symbols denoting finite quantities; because $a \div a = 1$, it would be erroneous to conclude that $0 \div 0 = 1$ or $\infty \div \infty = 1$. Expressions such as $0 \cdot 0$, $\infty \div \infty$, $\infty \cdot \infty$, $0 \cdot \infty$, and some others are called indeterminate forms; for methods of evaluating them, see Chrystal's *Algebra*, chap. xxv., or De Morgan's *Differential and Integral Calculus*, chap. x.

Infinitesimals is the name applied to the method adopted by Leibnitz as the foundation of his Differ-

ential Calculus. Leibnitz considered magnitudes as composed of infinitely small elements or infinitesimals. Those elements which are infinitely small compared to any finite magnitude are infinitesimals of the first degree; those which are infinitely small compared to infinitesimals of the first degree are infinitesimals of the second degree; and so on. The principle of the method briefly stated is that two finite magnitudes are equal if they differ only by an infinitely small magnitude. Though the results obtained by the application of infinitesimals are seen to be always in accord with the results obtained by other methods, and a method which always leads to correct conclusions must be logically sound, yet the fundamental principle does not at first sight seem rigorously exact, and the method looks as if it were merely one of approximation. In consequence it has now come to be usual to found the calculus on the doctrine of limits.

Infinitesimal Calculus. See CALCULUS.

Infirmaries. See HOSPITAL.

Inflammation is the most important of all the morbid processes that fall under the notice of the physician or surgeon. The most obvious symptoms or phenomena of inflammation, when it attacks an external or visible part, are pain, redness, heat, and swelling. If a healthy man gets a splinter of wood or any other foreign body imbedded in any fleshy part he begins to experience pain at the part, and this is soon succeeded by redness of the skin. In its early stages the process is known as irritation; but soon, if the foreign body be not removed, the pain and redness increase, and are accompanied by a firm and extremely tender swelling at and around the spot, and a sense of abnormal heat. These purely local symptoms are succeeded, if the inflammation reach a certain degree of intensity, by a general derangement of the vascular and nervous systems, to which various names, such as constitutional disturbance, symptomatic or inflammatory fever, &c., have been applied.

Numerous observers have attempted to trace the exact phenomena of inflammation, by microscopic examination of the transparent parts of animals in which the process has been artificially excited. From observation made on the web of the frog's foot and other transparent parts of animals by Wharton Jones, Paget, Cohnheim, Burdon Sanderson, Ziegler, and many others, the main features of the process are now well known.

In inflammation of moderate severity the blood-vessels of the part are seen to dilate, and the current of blood through them, at first sometimes a little accelerated, becomes much slower than the normal. In consequence of this retardation the white blood-corpuscles, being somewhat sticky in consistence, fall out of the central stream, and drag along the sides of the vessel, where, as the inflammation increases, they are arrested. Then follows the most remarkable part of the process. Minute buds are seen to form on the outside of the walls of the veins and capillaries, each one corresponding to a white blood-corpuscle in the interior. These buds grow larger at the expense of the corpuscles, which thus pass through the wall of the vessel without any break in its continuity; and the migration continues till the tissue around the vessels is crowded with corpuscles. At the same time an abnormal quantity of fluid exudes through the walls of the blood-vessels, and in part coagulates, forming with the corpuscles what is known as coagulable or plastic lymph. From the capillaries red as well as white blood-corpuscles pass into the tissues. If the inflammation be more intense complete arrest of the flow of blood in the vessels (stasis) takes place.

We may now consider the explanation of the cardinal symptoms of inflammation. The *redness*

depends upon there being more blood than usual in the blood vessels of the affected part; sometimes also upon the occurrence of hemorrhage in the inflamed tissue. The *swelling* depends in part upon the distension of the blood-vessels, but mainly upon the effusion of fluids and blood-corpuscles above described. These are termed the *products* of inflammation; and many changes, some of a reparative nature and others of an injurious tendency, depend upon their presence. The *pain* may vary from mere discomfort to intense agony. It is probably due to compression of the sensory nerves of the affected part by the dilated vessels, and the exudation. It is often throbbing. There is usually most pain in those parts in which the tension produced by the swelling is the greatest, as in bone, serous and fibrous membranes, &c. The pain occurring in inflammation is always aggravated by pressure, and by this means the physician can often distinguish between inflammatory and non-inflammatory disorders. The *heat* is seldom so much increased as the sensations of the patient would lead him to believe; it does not rise above the maximum heat of the blood in the interior of the body. This increase of heat depends upon the increased flow of arterial (or highly oxidised) blood to the part.

The blood obtained by bleeding a patient suffering from inflammation of any important organ usually presents a peculiar appearance after coagulation known as the *buffy coat* (see BLOOD). Another and a more important change in the blood in inflammation is the augmentation of the fibrin, which often rises to two, three, or more times its normal quantity.

The further course of inflammation is much more variable. The most favourable termination is *resolution*, where the products of the inflammation are gradually removed by the lymphatics, and the tissue returns to its normal state. If the exuded blood-corpuscles accumulate in large amount (*suppuration*) they form an Abscess (q.v.), and must in general be evacuated before cure can take place. If the inflamed tissue be superficial its outer layers may die and be thrown off (*ulceration*), leaving a sore which heals by Cicatrization (q.v.). If the inflammation be severe and extensive Gangrene (q.v.) or *necrotification* may ensue.

In the return to health of inflamed tissues, where neither resolution nor death of the patient has taken place, formation of new tissue is necessary to fill up the gap which is left by suppuration or ulceration. This is effected mainly by the action of the exuded leucocytes present in the 'plastic lymph,' which under suitable conditions becomes gradually organised into fibrous tissue, bone, &c.; but the restoration of the epithelial covering, where a breach in the surface either of skin or mucous membrane has occurred, is effected only under the influence of epithelial cells present at the edge of the gap. The process is essentially similar to the healthy repair of broken bones (see FRACTURE), or incised wounds, though many authorities do not apply the term inflammation to these cases. It is thus that parts recently severed from the body may be some times replaced and still live. The success of the Taliæotian operation, by which a new nose is grafted in the position of that which had been lost, of the operation of injecting a stimulating fluid into cystic tumours, with the view of setting up adhesive inflammation, and of various other surgical operations, essentially depends upon the property of organisation possessed by inflammatory exudation, or closely allied products. Although the organisation of plastic lymph is thus essentially a conservative and reparative process, it leads in many cases to untoward results. Thus, when a serous membrane (e.g. pleura, pericardium, peri-

tonium) is inflamed, the exudation between its contiguous surfaces often becomes transformed by the same process into fibrous tissue, forming layers or bands which seriously interfere with the functions of the organs involved (lung, heart, intestine, as the case may be) after the inflammation has subsided. In inflammation of the iris the pupil may be rendered irregular or immovable, or may even be closed up by inflammatory exudation. In endocarditis, or inflammation of the lining membrane of the heart, exudation may be deposited in wart-like masses on the valves, and may thus occasion some of the worst forms of cardiac disease.

The causes of inflammation are very various. Among predisposing causes must be reckoned any condition which lowers the vitality of the whole body, or of any particular part of it. The most obvious exciting causes are mechanical violence, chemical irritants, excessive heat or cold, producing injury of a part of the body which leads directly to inflammation in that part. Less obvious, but not less certain, is the effect of exposure to cold in exciting inflammation of internal organs. But of all the causes the most important undoubtedly, though they have only been recognised within the last three decades of the 19th century, are micro-organisms—bacteria, &c. (see GERM). Besides the numerous *specific* diseases attended by inflammation of various organs and tissues proved or believed to be due to these bodies, many forms of what is known as *simple* inflammation—e.g. acute abscess—have been shown to be associated with them. Some authorities go so far as to say that no true inflammation can take place without them; and though this opinion has not been proved, it is certain that almost all the most severe forms of inflammation are characterised by the presence of some form of micro-organism.

The inflammatory diseases of the most important organs are described under their specific names, and, as a general rule, the termination *itis* is employed to indicate an inflammation. Thus, peritonitis signifies inflammation of the peritoneum; iritis, inflammation of the iris; &c. Inflammation of the lungs, however, is usually known as pneumonia instead of pneumonitis, and of the pleura as pleurisy instead of pleuritis. See PNEUMONIA, PLEURISY, ENTERITIS (for inflammation of the bowels), PERITONITIS, STOMACH (for gastritis), LIVER (for hepatitis), EYE (for iritis), BRAIN, &c.

It is unnecessary to enter into the consideration of the treatment of inflammation further than to remark (1) that if possible we must remove its exciting cause, which can seldom be done except when the inflammation is external; and (2) that the patient should be placed on a strictly anti-phlogistic regimen (which implies a total abstinence from solid animal food and stimulating drinks, due attention to ventilation, temperature, &c.). Of the direct remedies, one of the most powerful, both for good and evil, is blood-letting, although at present it is rarely used. The medicines chiefly employed are purgatives, preparations of mercury, tartar emetic, and opium; while, as external applications, hot fomentations or poultices (sometimes applications of cold water or ice are preferable), and counter-irritation by means of blisters, sinapisms, setons, &c., are often of service.

Inflection. See GRAMMAR.

Inflorescence. This term is applied by botanists in a concrete and special, as well as in an abstract and general sense—i.e. first to any single group or natural aggregate of flowers arising upon a common main axis, and secondly to the various modes or principles of floral arrangement themselves. Despite that endless superficial diversity upon which the characteristic aspect of different

species and larger groups so much depends, these apparently indefinite variations may readily be reduced to a small number of easily intelligible types. For, while the earlier botanists naturally tended to develop a nomenclature corresponding to the multiplicity of outward forms which inflorescences acquire, the progress of research has simplified this by centering attention upon the few and simple modes of branching by which they arise. We naturally set out with any plant of which the axis continues to grow indefinitely, but of which a number of secondary axes arising in the axils of the leaves are developed as flowers. When the pedicels of these flowers tend to reach a moderately equal length the inflorescence is known as a *raceme* (fig. 1, *a*); or when the process of floral development arrests them, so that the flowers are practically sessile, we have a *spike* (fig. 1, *d*). The growing point of most racemes and spikes, however, tends to be checked by the reproductive stress, and the axis thus frequently ends, or rather seems to end, in a terminal flower. Good examples of this essentially racemose or spikeate type are furnished by many Liliaceae, Scrophulariaceae, &c. —



Fig. 1.

a, raceme of lily of the valley (*Convallaria*); *b*, corymb of candy-tuft (*Iberis*); *c*, umbel of fruits of fennel (*Foeniculum*); *d*, spike of vervain (*Verbena*); *e*, head of fruits of dandelion (*Taraxacum*); *f*, *Dorstenia*; *g*, *fig* (*Ficus*) in vertical section.

e.g. *Tritoma*, foxglove, mullein, &c. Even such a curious inflorescence as that of the pine-apple may now easily be interpreted as a greatly condensed spike of fruits, crowned by its leafy growing point.

The shortening of the main axis of a raceme may take place after ordinary development has begun, so that the upper internodes are much less developed than their predecessors. The pedicels of the younger flowers naturally share the same arrest of development, and thus it is that the comparatively long pedicels of the lower flowers place them on much the same level as the higher ones, and even as the summit of the axis. This variety is known as the *corymb* (fig. 1, *b*), so familiar in the candy-tuft. When all the internodes are so shortened that the pedicels arise from practically the same level, we have the *umbel* (fig. 1, *c*), so characteristic of the Umbelliferae.

Suppose this vegetative arrestment and floral precocity to be continued still further, internodes and pedicels alike become arrested, and the result is a crowded cone or excessively shortened spike of sessile flowers. By continuing the same process which gave us the corymb, the cone necessarily tends to appear more and more depressed through the more rapid upgrowth of its lower portions; thus we have that characteristically expanded axis, so compactly set with florets as to resemble at first sight a single flower, familiarly

known as the head or capitulum of the Composites (fig. 1, *e*). The spiral arrangement of the florets so obvious in a sunflower is simply that of the depressed cone, which we may again draw out in imagination into the corymb, the spike, or the raceme, with which it is in principle identical.

A capitulum fundamentally similar may, however, be evolved in a slightly different way, by the more or less complete arrestment of the secondary axes of an umbel. Hence it is that a few umbelliferous plants, like *Astrantia*, or still better the sea-holly (*Eryngium*), &c., come to present that appearance which so often induces the beginner to confuse them with Composites.

But, since it is manifest that the same embryonic shortening may occur in any type of inflorescence whatsoever, it becomes evident that we must reserve the term capitulum for the type of inflorescence presented by the Composite or Scabious, leaving the various superficially resemblant forms or *pseudo-capitula*, as of sea-holly already referred to, or those of sea-pink, of bergamot, &c., to be separately analysed according to their true origin.

Returning, then, to the capitulum proper, we must continue to keep clearly in view that conception of vegetative growth (as reaching its maximum rate only at some distance behind the growing point) which may be actually verified by measurements of any growing shoot or root. The conical axis thus not only tends to broaden and flatten, but its lower portion must at length overtake the apex, and a perfectly flat receptacle, as in some species of *Dorstenia*, results. The margins next outgrow the apex, and the cone is now becoming a shallow saucer (other species of *Dorstenia*, fig. 1, *f*). The saucer next becomes a cup, or even flask; and the remarkable hollow inflorescence of the fig (fig. 1, *g*) is thus seen to be morphologically akin to the capitulum, and through this by the corymb even to the original raceme itself.

The study of vegetative branching (see BRANCH) has, however, shown us that we may have to do with compound or sympodial axes as well as simple or monopodial ones. That is to say, in our primary axis the growing point may perish, leaving, however, of course, all the more opportunity for the development of the secondary axes latent in its lateral buds. This disappearance of the primary growing point, having once set in, soon works back, until we have it occurring immediately after the development of the first lateral bud. This then readily takes its place for practical purposes, just as a larch or pine which has lost its top renews it by the upgrowth of a branch. But the new axis dies in turn after giving birth to its successor, and so on; thus the *falsæ axis* or *sympodium* is formed. Inflorescences of this type are known as *cyms*. The simplest in principle is that of the Day-lily (q.v.). It is commonly known as the *helicoid cyme* (fig. 2, *h*), since the origin of the new axes winds on in the same spiral order as that of the leaves upon the primary axis itself. The distinction from a raceme is, however, easily made when we notice that the so-called bracts are not really bracts at all, but are more or less opposite to the flowers; being really only the axillant leaves of the next axis, which bears its flower only after producing a leaf with the bud of its successor.

But in other cases the spiral may change its direction with each new axis, and the false axis thus assumes a very different appearance, that of the *scorpioid cyme* (fig. 2, *i*), of which the classical example is furnished by the Boraginaceae (Goebel, however, regards these as unilateral racemes, and offers *Tradescantia*, *Echeveria*, &c. as more real types). The reversal of the spiral has been prettily verified by noting how in the scorpioid cyme of the

Rock-rose (*Helianthemum*) the spiral of the calyx runs in an opposite direction in each successive lower.

So far we have been dealing with cymose inflorescences as arising in plants with alternate leaves: in opposite leaved plants (e.g. Caryophyllaceae and Begonia (q.v.)) the resultant form is necessarily very different. Let the growing point terminate in a flower as before; but since each of the two leaves immediately below is in an equally favourable condition, both as regards radiation and aliment, we have two secondary axes instead of one. Hence, instead of one secondary axis continuing in the line of the primary one, we have necessarily two of equal strength and divergent at an equal angle. The main axis thus at first sight



Fig. 2.

Diagrammatic representation of *b*, helioid cyme; *a*, scorpioid cyme; *c*, dichloasium.

seems to have forked, especially when the terminal flower disappears, just as in the false dichotomy so apparent in the branches of the lilac or mistletoe; and hence the old name of *dichotomous cyme*, which, however, it is evidently necessary to correct, as *dichloasium* (fig. 2, *b*), *biparous cyme*, or the like.

This inflorescence may undergo shortening, or in more physiological language remain more or less embryonic, as in most Labiate (which, however, present all gradations, from the fully-developed cymes of *Hyssopus*, through the 'false whorls' or 'verticillasters' of the majority of genera, to the terminal pseudo-capitulum of *Bergamot*). The apparent umbel of geraniums and the pseudo-capitulum of the sea-pink have also this origin.

Not only modifications of these leading types, but various combinations, simple, compound, and complex, and in all degrees of reduction or exuberance, may also arise; the question of separating all the preceding types of inflorescence as *radial* from a small residuum as *basal-central* also presents itself. See Goebel's *Outlines of Classifications* and Van Tieghem's *Traité de Botanique*.

Influenza (Ital., 'influence'; called in French *le grippe*), one of the class of diseases to which the term zymotic has been applied, has been long recognised by medical writers. The popular application of the name to any severe cold in the head is not sanctioned by medical authority. Cullen called it *catarrhus cataractae*, but although, in most cases, it closely resembles ordinary catarrh, it presents certain points of difference from that disease. In addition to the ordinary symptoms of catarrh, there is a sudden, early, and very striking debility and depression of spirits. This early debility is one of the most marked and characteristic signs of influenza. The mucous membranes (especially those of the respiratory organs) are much affected. The tongue is white and creamy, the sense of taste is lost, there is no appetite, the

pulse is soft and weak, the skin, although at first hot and dry, soon becomes moist, and the patient complains of pains and soreness in various parts of the body.

In simple, uncomplicated cases convalescence supervenes in the course of a week or sooner; but influenza is very frequently conjoined with bronchitis or pneumonia, in which case it is much more persistent and dangerous. There is, moreover, an extreme proneness to relapse on the slightest exposure, even after the patient feels perfectly recovered.

Influenza affords an excellent example of an epidemic disease, a whole community being often attacked in the course of a few hours. From this it may be inferred that the occurrence of this disease is connected with some particular condition of the atmosphere, but what that condition is is not known. Not infrequently influenza follows close upon a sudden thaw; sometimes it is preceded by thick, ill-smelling fogs; but hot and cold, wet and dry weather have all been attended by severe outbreaks of the disease. Like cholera, influenza generally, but by no means constantly, follows a westerly direction, or one from the south-east towards the north-west, and its course seems to be altogether independent of the surface currents of air, as it often travels against the prevailing wind.

The epidemic which prevailed during the winter of 1889-90 in most parts of the civilised world, the first of importance in Britain for nearly forty years, presented some points of difference from most of the previously recorded outbreaks. In particular, there was in many places a much larger proportion of cases without any catarrhal symptoms whatever than appears to have been observed before. Such cases present a close resemblance to Dengue (q.v.), and many observers have come to the conclusion that there is a much closer relation between the two diseases than has been hitherto supposed; while some believe that the epidemic in question was itself dengue modified by climate, and not influenza at all.

The most important point in the treatment of influenza is *not* to bleed the patient, or in any way to depress his vital powers. He should be kept in bed; his bowels should be gently opened, his skin slightly acted upon, if dry; and, if the cough be troublesome, a mustard-poultice should be applied to the chest, and an expectorant mixture prescribed. Antipyxin and antifebrin were during the epidemics of 1889-95 found very valuable in combating the feverishness and pain of the early stage. In persons of weak or broken-down constitutions, ammonia, beef-tea, and wine and water must be given from the outset. The debility that often remains for a considerable period after the establishment of convalescence is best met by the preparations of iron, quinine, and strychnia.

Few diseases increase the death-rate to such an extent as influenza; more, however, in consequence of the great number of persons who are attacked in a severe epidemic than in consequence of its danger in individual cases. See EPIDEMIC, GERM.

In Forma Pauperis (in the character of a poor person). Persons are said to sue *in forma pauperis* when the law allows them to conduct lawsuits without paying fees to court-officers, counsel, or solicitors. In England a statute of Henry VII. affirming the common law, provided that such as would swear themselves not worth £5, except their wearing apparel and the matter in question in the cause, should be exempt when plaintiffs, but not when defendants, from the payment of court fees, and should be entitled to have counsel and attorney assigned to them by the court without fee. They were further exempted from costs when unsuccessful; a privilege which, according to Blackstone, amounted

in former times only to the rather uncomfortable alternative of choosing between paying and being whipped. This indulgence, first confined to plaintiffs, was afterwards extended to defendants. It was at first restricted to the Common Law Courts, but afterwards adopted in the practice of the Equity and Probate and Divorce Courts. No one can sue *in forma pauperis* unless the opinion of counsel on his case, and an affidavit by the party or his solicitor that the same case contains a full statement of the material facts, be produced to the court applied to. A suitor *in forma pauperis* is not entitled to costs unless by order of the court. In Scotland an Act of 1424 established the poor's roll to secure a like privilege to poor persons there.

Information. See CRIMINAL LAW.

Informers. In English law, the person who sues for a penalty under some statute. In many statutes which define offences—not criminal, but savouring of criminality—encouragement is often given to persons who are willing to sue on behalf of the crown, the pecuniary penalty or part of it being given to the informer. This kind of action is called a *qui tam* action, from the use of the words *qui tam pro domini regniū quam pro seipso*, &c. In criminal proceedings an accomplice who turns king's evidence, if accepted as a witness by the crown, is called an approver or prover. Ever since the days of the professional 'sycophant' at Athens the informer has been regarded as an odious character. In Ireland, owing to the unsatisfactory relations between the government and the people, almost any person who gives evidence against a prisoner runs the risk of making himself unpopular. In Chancery proceedings at the suit of the attorney-general the informer is called a relator. In Scotland an informer is the party who sets the Lord Advocate in motion in criminal prosecutions, and the Lord Advocate is bound to give up the name of the informer, who is liable in case of malicious prosecutions. See APPROVER, SPY.

Infusions are aqueous solutions of vegetable substances obtained without the aid of boiling. In this respect only do they differ from decoctions, in the manufacture of which boiling is resorted to. Infusions are prepared by digesting the vegetable substance (root, bark, &c.) in hot or cold water in a covered earthenware vessel. Cold water is preferable when the active principle is very volatile, or when it is desired to avoid the solution of some ingredient in the vegetable which is soluble in hot, but not in cold water. For example, in preparing the infusion of calumba cold water is preferable, because it takes up the bitter principle (which is the essential ingredient), and leaves the starch-matter undissolved. In most cases, however, boiling water is employed. Infusions are preferred to decoctions when the active principle volatilises at a boiling heat, as in the case of essential oils; or when ebullition readily induces some chemical change, as in the case of senna.

Infusions may also be prepared by Percolation (q.v.), a process which is extensively employed in the preparation of tinctures. When thus prepared they are less liable to decay than when prepared on the old system.

The fresh infusion, while possessing a finer flavour, is in danger of being superseded in pharmaceutical practice by the concentrated infusion. On account of the trouble and expense involved in making small quantities of the fresh preparations, recourse is frequently had to the concentrated ones, which, when diluted with seven times their bulk of distilled water, more or less represent the fresh article. Where the active principle is a volatile one it is very difficult to retain the full aroma in the concentrated state, and to

this question much pharmaceutical attention has been turned. The concentrated infusions contain from 20 to 25 per cent. of alcohol, which is essential for their preservation. The simple infusions may be preserved for a short time by the addition of a trace of chloroform.

Infusoria, a name given to several classes of active Protozoa, some of which appear in great numbers in stagnant *infusions* of animal or vegetable matter. The great majority are provided with vibratile locomotor processes of their living matter, usually in the form of cilia or flagella; and, though these may be retracted when the animal occasionally encysts itself, they are practically permanent, and express the predominantly active constitution of these cells. Most are microscopic, but many are readily seen when foul water is held in a glass vessel between the eye and the light. Yet there may be more Infusorians in a cup of stagnant water than there are people on the globe. Infusorians occur both in fresh and salt water, and a few are parasitic; they feed on vegetable or on animal matter, on bacteria or on one another, while some possessed of a green pigment, closely allied to, if not identical with chlorophyll, probably absorb carbonic dioxide after the manner of plants. Most Infusorians possess a 'mouth'—i.e. a special aperture through which the food-particles are wafted in by the cilia or flagella. As single cells, comparable to the units of ciliated epithelium in multicellular animals, to the active spores of plants, and to male cells or spermatozoa, they exhibit the usual protoplasmic structure and the central differentiation or nucleus. There is usually a definite rind, often with cuticular structures; and there are generally contractile vacuoles, probably excretory in function. Many Infusorians occur not as single individuals, but as members of a colony, the results of multiplication remaining clubbed together, and often forming masses easily visible to the unaided eye. They multiply with great rapidity by dividing into two, or by rapid successive division into a larger number (spore-formation); and thus a single Infusorian, with favourable temperature and nutrition, may in four days become the ancestor of a progeny of a million, in six days of a billion, in seven and a half days of a hundred billions—weighing one hundred kilogrammes! If the life of the species, however, is to be sustained, conjugation or incipiently sexual union of two Infusorians (not of the same family) must occur, for if the descendants of one individual be left by themselves the whole family falls victim to 'senile degeneration,' and the members dwindle away. In many cases among ciliated Infusorians the researches of Maupas and others have shown that the conjugation of two forms means an interchange of nuclear elements; in other cases the two individuals fuse into one. When the two conjugates are of unequal size, as in the common *Vorticella* or bell animalcule, it seems justifiable to call the smaller male and the larger female.

The classes included under the title of Infusorians are as follows, beginning with those ciliated forms to which zoologists often restrict the term.

Ciliata.—Infusorians characterised by the predominance of alternately bent and straightened motile processes known as cilia. The usual nucleus is accompanied by a second neighbour nucleus (para- or micro-nucleus), the elements of which are interchanged in conjugation. They are classified according to the relative position and size of their cilia. The slipper-animalcule (*Paramecium*), and *Opalina* parasitic in the intestine of the frog illustrate those which are more or less completely ciliated (*Holotricha*); the beautifully coloured species of *Stentor*, the genus *Balantidium*, with one species parasitic in man, and the common *Bursaria*

are among those with heterogeneous cilia dissimilar in size and form (Heterotricha); the stalked bell-animalcule Vorticella and its beautiful allies Epistylis and Carchesium, the jumping Halteria, with a girdle of springy, bristle-like processes, and Opalidium, which multiplies into large hollow colonies, sometimes 5 inches across, have a special wreath of cilia round the mouth (Peritricha); and lastly, those with cilia restricted to the under surface are well illustrated by Euplotes, Oxytricha, and Stylonielia.

Flagellata.—Infusorians with a vibratile or undulatory flagellum, or with more than one, used for locomotor or food-catching purposes, including a vast number of forms, some of which are often called Monads, while others—e.g. Volvox—approach if they do not unite with the Algae. One of the very commonest flagellate genera is Englena. To the flagellates proper there have to be added the Choanoflagellata, with a single flagellum surrounded by a beautiful wine-glass like collar—e.g. Salpingoeca, and the interesting Proterospongia—a colony with slight division of labour among its members and like a little fragment of sponge flesh; also the Dinoflagellata, with two flagella, one parallel, the other transverse to the long axis of the body—e.g. Peridinium, an extremely common marine form, affording food to some fishes; lastly, the Rhynchoflagellata, with a large locomotor flagellum, including two genera—the phosphorescent marine ‘night-light’ (Noctiflumen), and Leptodiscus, a beautiful bell-like form, which seems within the compass of a single cell like a far-off prophesy of medusoid architecture.

Suctoría or Suctorialia.—Infusorians with cilia only in their free-living youth, usually fixed as adults, and always with prehensile or suctorial processes like tentacles, by means of which they prey upon other Protozoa. Acineta and Podophrya are suctorial; the common Acineta is only prehensile.

In beauty of form and movement, in the liveliness of their behaviour, and in the intricate phases of their life-history, Infusorians afford almost inexhaustible material for investigation, which many workers have shown to be at once captivating in itself and full of biological suggestiveness. In the general economy of nature Infusoria are especially important as a food-supply to small animals, and in so far as they unite with Bacteria in working decaying matter once more into the cycle of life, or in reducing it to simpler elements.

See BACTERIA, MONAD, PARAMOECIUM, PROTOZOA, VORTICELLA; Claparede and Lachmann, *Études sur les Infusoires* (Geneva, 1858-61); Stein, *Organismus der Infusorien-Theorie* (Leip. 1859-83); Saville Kent, *Manual of the Infusoria* (Lond. 1880-82); Ray Lankester, article ‘Protozoa,’ *Encycl. Brit.* (1885); Maupas, *Archiv. Zool. Expér.* (vi. 1888); Batschli, ‘Protozoa,’ in Bronn’s *Thierreich*.

Infusorial Earth. DIATOM EARTH, KIESELGÜHR, a siliceous deposit formed chiefly of the frustules of Diatoms (q.v.). It is used as *Tripoli Powder* for polishing purposes, and as an absorbent of nitro-glycerine in making Dynamite (q.v.).

Ingelheim. LOWER and UPPER, two small German towns, 10 miles E. of Bingen. The former (pop. 3000) claims to be the birthplace of Charlemagne, and has ruins of the magnificent palace he built here; the latter (pop. 3300) was once a free city of some importance.

Ingelow. JEAN, a popular poetess and novelist, was born at Boston, Lincolnshire, in 1820. Her first efforts in verse were published anonymously in 1850 under the title of *A Rhyming Chronicle of Incidents and Feelings*. These gave indication of considerable power, as well as of the influence of Tennyson and Mrs Browning, to whose writings she appears to have been strongly drawn in youth.

A good deal of Miss Ingelow’s poetry is of a devotional or religious cast, introspective in quality and melodious in style. But she has also written some powerful ballads, and of her minor pieces *The High-tide on the Coast of Lincolnshire, 1551*, is probably both the finest and the best known. Of her larger poems *A Story of Doom* (1867) has been the most successful. To about the same time belong *Deborah’s Book and the Lonely Rock, Grandmother’s Shoe, The Suspicious Jorklaw, The Life of John Smith, The Minnows with Silver Tails, Studies for Stories*. Among her novels may be mentioned *Off the Skellogs, Fated to be Free* (1875), *Don John* (1876), and *Sarah de Berenger* (1880). An edition of poems appeared in 1880-87 (3 vols.) She died 20th July 1897.

Ingemann. BERNHARD SEVERIN, Danish poet and novelist, was born, May 28, 1789, at Thorkildstrup, in Falster. He first wrote lyrics (*Proem, &c.*), and then collections of *Fairy-tales and Stories*. But his best works were a series of historical novels, in which he took Walter Scott for his model—*Valdemar Seier* (1826), *Erik Menved’s Childhood* (1828), *King Eric* (1833), and *Prince Otto of Denmark* (1835). The poems *Valdemar the Great and his Men* (1824), *Queen Margaret* (1836), and *Holger Danske* (1837), which are based, like his novels, on incidents of Danish national history and tradition, rank among Ingemann’s most successful efforts. Besides being prolific he was also versatile, and essayed his hand in nearly all branches of pure literature, not the least estimable of his productions being *Psalms* (1825). From 1822 he taught Danish language and literature in the Royal Academy of Sorø, near Copenhagen. His collective works were published in 39 vols. (1843-64). He died 24th February 1862.

Ingermanland. the old Swedish name for which is now the government of St Petersburg.

Ingersoll. JARED, an American jurist, born in Connecticut in 1749, studied at Yale and in London and Paris, and became a prominent lawyer in Philadelphia. He was a member of congress in 1780-81, was in 1787 a delegate to the convention that framed the Federal constitution, and in 1812 was the Federalist candidate for the vice-presidency of the United States. He was a judge in the district court of Philadelphia at the time of his death, 31st October 1822.—His son, CHARLES JARED, born in Philadelphia, 3d October 1782, sat in congress in 1813-15, and there advocated the principle that ‘free ships make free goods;’ was for fourteen years United States district attorney for Pennsylvania; and was a prominent leader of the Democrats in congress from 1841 to 1847. He died 14th May 1862. He was the author of some poems and a drama, a political satire entitled *Washington’s Letters* (1810), and an *Historical Sketch of the War of 1812* (4 vols. 1845-52).

Ingersoll. ROBERT GREEN, was born at Dresden, New York, 11th August 1833, the son of a Congregational minister of very broad views. With his brother he opened a law office at Shawneetown, Illinois, but removed in 1857 to Peoria. In 1862-65 he was colonel of a Federal cavalry regiment; in 1866 he was appointed state attorney general. He was a successful lawyer, a well-known Republican campaign orator, and attracted more notice than he deserved by his lectures directed against the Christian religion, and by many pamphlets and books published with the same object. He died 21st July 1899.

Ingleby. CLEMENT MANSFIELD, an eminent Shakespearean scholar, was born at Edgbaston, Birmingham, 29th October 1823, was educated privately, and afterwards proceeded to Trinity College, Cambridge, where he graduated B.A. in

1847, and became M.A. in 1850, and LL.D. in 1859. He entered his father's office as a solicitor, and practised for a short time, though by no means assiduously; or *con amore*; and after his father's death in 1859 relinquished the profession altogether to devote himself to a busy life of letters. He was one of the two English honorary members of the Weimar Shakespeare Society, an original trustee of Shakespeare's birthplace, a vice-president of the New Shakespeare Society (a post he afterwards resigned), and successively foreign correspondent and vice-president of the Royal Society of Literature. He died 26th September 1886.

His earliest work, *Outlines of Theoretical Logic* (1856), was followed by *An Introduction to Metaphysics* (1864-69) and *The Revival of Philosophy at Cambridge* (1870). But the most important work of his literary life began when he published *The Shakespeare Fabrications* (1859) and *A Complete View of the Shakespeare Controversy* (1861). These were followed by *Was Thomas Lodge an Actor?* (1868); *The Still Lion* (1874), enlarged into *Shakespeare's Heresies* (1875); *The Centurie of Praise* (1874); *Shakespeare: the Man and the Book* (1877-81); *Shakespeare's Bonus* (1883); *Shakespeare and the Enclosure of Common Fields at Wilton* (1885); and an edition of *Cymbeline* (1886). A selection of admirable *Essays* on a wide range of subjects was issued in 1888 by his son, Holcombe Ingleby, who prepared in the same year, for private circulation, a brief memoir of his father, with a collection of his epigrams, translations, and verses.

Ingoldsby, THOMAS. See BARHAM.

Ingolstadt (called *Auracant* and *Chrysopolis*, i.e. 'the golden city'), a town and first-class fortress of Bavaria, on the left bank of the Danube, 53 miles by rail N. of Munich. It contains two castles of the former dukes of Bavaria-Ingolstadt (now used for military purposes); the Gothic church of Our Lady (1425), in which is the tomb of Eck, Luther's opponent; and the former Jesuit college. Brewing, cannon-founding, and the manufacture of gunpowder and salt are the only industries. Pop. (1875) 14,474; (1885) 16,390, mostly Roman Catholics. A university was founded here in 1472, which reckoned Renclin and other eminent scholars among its professors, and a century after its foundation had 4000 students. It was removed to Landsbut in 1800, and to Munich twenty-six years later. Ingolstadt was the first German town at which the Jesuits were permitted to establish themselves, and to teach publicly from the university chairs. Loyola gave it the fond title of 'his little Benjamin.' Here, too, Adam Weishaupt established the Illuminati (q.v.). Ingolstadt, which existed in the 9th century, was first fortified in 1539. In 1827 the fortifications, which had been destroyed by the French in 1800, were restored upon a first-class scale. See works by Gerstner (1853) and Kleemann (1883).

Ingraham, JOSEPH HOLT, author of *The Prince of the House of David*, was born at Portland, Maine, in 1809, was for some time a sailor, and afterwards taught languages at a college in Mississippi. He published a string of wild romances, such as *Captain Kyd* and *Lafitte, or the Private of the Gulf*; but after he was ordained to the Episcopal ministry, in 1855, he chose biblical subjects for his stories, and wrote *The Prince of the House of David* (1855), *The Pillar of Fire* (1859), and *The Throne of David* (1860). He died in 1860.

Ingres, JEAN DOMINIQUE AUGUSTE, French painter, was born at Montauban, 15th September 1781. He became a pupil of David in 1796, and five years later gained the 'Grand Prix.' In 1806 he proceeded to Rome, where he resided for four teen years. He then spent four years in Florence, where he painted 'The Yow of Louis XIII.,' a picture which, on being exhibited at the Paris

Academy in 1824, broke down the indifference of the public to the work of David. In Italy he had adhered to the style of David, but had modified it by the inspiration he got from Raphael and other old masters. To this period belong his best portraits, and his 'Edipus and the Sphinx,' 'Venus Anadyomene,' 'Romulus and Aeron,' 'Virgil reading the *Æneid*,' 'Raphael and Fornarina,' 'Roger and Angelique.' Returning to Paris in 1826, Ingres was appointed professor of Fine Arts at the Academy, and became the recognised head of a great school. But the acrimonious criticism passed upon his 'Apotheosis of Homer' (1827) and 'Martyrdom of St Symphorian' (1834) made him gladly embrace the opportunity of succeeding Horace Vernet as director of the French Academy in Rome in 1834. There he painted 'Stratonice' and the 'Portrait of Cherubini.' The exhibition of these and other pictures in Paris at length turned the tide of popular admiration full and strong in his favour. He relied more upon form and line than upon colour; some of his best productions ('Girl after Bathing,' 'Edipus and the Sphinx,' the 'Odalisque,' and the 'Fontaine'), compositions of a few figures each, are unquestionably deserving of admiration; but of late it is commonly held that for a time he was unduly overrated. At the exhibition of 1855 he was awarded the grand medal of honour for his collection of pictures, and was nominated a grand officer of the Legion of Honour. He returned to Paris in 1841, and died there on 14th January 1867. See Lives by Delaborde (1870), Blanc (1870), and Schmarsow (1884; in Dohme's *Kunst und Künstler*).

Ingria. See ST PETERSBURG.

Ingrossing. See ENGRASSING.

Ingulph, abbot of Crowland, long considered the author of the *Historia Monasterii Croylandensis*, according to Ordericus Vitalis, was secretary to Duke William of Normandy, and was by him in 1086 made abbot of Crowland, where he died, 16th November 1109. The *Historia Monasterii Croylandensis* was printed by Sir Henry Savile in his *Scriptores Rerum Anglicarum post Bedam* (1596), and in a more complete edition, with the continuation by Peter of Blois, in vol. i. of the *Rerum Anglicarum scriptores ceteros* (Oxford, 1684). There is a translation by H. T. Riley in Bohm's *Antiquarian Library* (1854). Some writers even of the 18th century questioned the entire genuineness of the book; but their scepticism did not proceed further than the hypothesis of interpolations by a later writer. But in 1826, in the *Quarterly Review*, Sir Francis Palgrave endeavoured to prove that the whole so-called History was little better than a novel, and was probably the composition of a monk in the 13th or 14th century. This has been conclusively proved, as the student will find, by Mr Riley in the *Archæological Journal* (vols. i. and ii.), and by Sir T. D. Hardy in the *Descriptive Catalogue* (vol. ii.).

Inhambane, a Portuguese station, capital of a district on the east coast of Africa, lies just south of the tropic of Capricorn, and is beautifully situated on its bay, but unhealthy. The town dates from 1764, and has 6500 inhabitants, of whom some 70 only are Europeans.

Inheritance. See HER. INTESTATE, WILL, SUCCESSION, HEREDITY.

Inia (*Inia geoffrensis*), a toothed fresh-water Cetacean, not unlike a dolphin, but with certain anatomical peculiarities which keep it outside that family. It is found in some of the upper tributaries of the Amazons, and in the lakes near the Cordilleras. It measures about 8 feet in length, has a long cylindrical snout with stiff hairs, and a very

slight dorsal fin. It feeds chiefly on fish, and is hunted for the sake of the oil which it yields. It



Inia.

is generally found in little troops of three or four. The females show great affection for their young.

Initials. Though in general it is usual and regular in all legal deeds and writings for a party to write his ordinary signature in full, yet in many cases, especially in documents of a mercantile nature, signature by initials will bind equally with the full signature. If, however, the subscription to a bill of exchange be by initials or marks it will not warrant summary execution; and the pursuer of an action on the bill will have to prove that such initials or marks are the party's usual mode of subscribing.

Injections. This term is applied in medicine to fluids thrown into the passages or cavities of the body by means of a syringe or elastic bag. The fluids thus injected into the *rectum* or lower bowel are termed *Clysters* (q.v.). Hypodermic Injections are treated under that head. See also TRANS-FUSION OF BLOOD.

Injector. Fig. 1 shows in section a simple form of injector for raising water. Steam issuing from the pipe S, into the vessel WR, will first create a partial vacuum above W by dragging air with it, and then, when the water-level is above the nozzle, will, on collapsing by condensation, impart its energy to the water and drive it up through the narrow neck below R, to a height of about one foot for every pound of steam-pressure per square inch. It is doubtful whether these injectors can work so economically, as regards expenditure of steam, as ordinary slow-moving pumps do; but they possess many conveniences and advantages which are bringing them into use.

Feed-pumps, for feeding water into steam-boilers, are difficult to keep in order when driven at high speed. The very rapid action of the valves severely tries their durability. In the case of locomotives inconvenience was often occasioned by the fact that their feed pumps acted only when they were running; and thus, if an engine happened to stand still for any length of time, the water occasionally got too low in the boiler. M. Henri Gillard's injector, now in general use in place of high-speed feed-pumps, acts equally well whether the engine is running or at rest.

The diagram fig. 2 will give an idea of the essential parts of Gillard's injector. A is the steam-boiler, B the water-level, CDE a pipe into which steam is admitted; this pipe terminates in a cone DF, which is enclosed in a larger cone III. In the cone DF the pointed plug E can be raised or

lowered so as to increase or diminish the area of the aperture at its lower end E. G is a pipe communicating with the water cistern, and admitting water into the external cone III. K is a pipe communicating with the boiler under the water-level. On opening communications between the boiler and this apparatus it might be expected that steam would rush out at F, and water at K, both currents meeting with great force, and escaping into the atmosphere between the two openings.

Paradoxical as it may appear, the water at K, although it is actually, by reason of the head of water arising from the difference of level between the aperture at K and the water-level at B, subject to a greater boiler-pressure than is the steam in the cone DF, is yet overpowered, and driven back into the boiler by the stream of water and condensed steam issuing from H; and thus water, from the pipe G and the

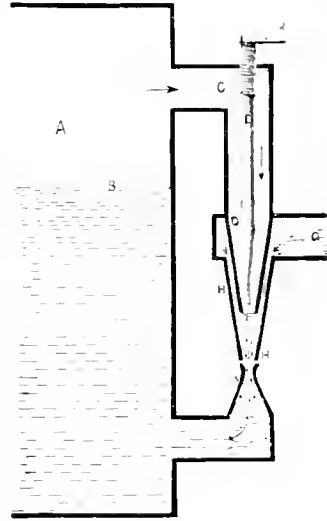

Fig. 2.

tender or cistern, is introduced into the boiler, and constitutes the feed-water. The energy of the collapsing steam at F is transferred to water in III; this is driven forward in a stream, which is at its narrowest at K; in this stream the actual energy per unit of bulk at K thus comes to exceed the potential energy of the boiler-water at K, and its actual velocity to exceed the possible velocity of outflow from K; whence the outflow from K is overpowered. In practice this injector is a somewhat expensive apparatus in consequence of the number of adjustable parts required. Variations in the pressure of steam require alterations in the area of the steam-passage, and in the distances between the mouths of the conical openings for the outflow and inflow of steam and water.

Injunction. in English law, is an introductory writ, by which a superior court stops or prevents some inequitable or illegal act being done. If the party disobeys the injunction he may be attached for contempt of court, and imprisoned till he obeys. In Scotland a remedy of a similar kind is called an Interdict (q.v.).

Ink is a general term for any fluid substance which, when applied to a suitable surface, leaves upon it a partially or wholly indelible impression. Any such fluid may be used for writing purposes; but, as the recording material is generally paper, this fluid must have either an affinity for the fibrous matter of which the paper is made, or for the sizing material used to produce upon it a homogeneous surface. This is necessary to prevent the removal of the ink by water; and this power of mounting itself is one of special importance, as upon it depend the permanency and indelibility of the records. Certain salts have this property, especially salts of iron, which when exposed to the air absorb oxygen, the result of which is that the pale blue

green solution produced by mixing proto-salts of iron with vegetable matters containing tannic or gallic acid is converted into a dense blue-black insoluble compound, which cannot be removed from the paper unless it is tampered with by means of chemicals capable of decomposing or destroying it. It is owing to the formation of this insoluble compound that writing-ink, when left in open vessels exposed to the air, becomes thick andropy, and unfit for use. Other black inks are prepared from salts of chromium and vanadium. These inks are in some cases more suitable than the simple writing-inks described above. Sulphate of indigo is also used as a colouring matter. A black ink which lays claim to indelibility is prepared from nigrosine, one of the aniline compounds; but the colour is much inferior to that of ordinary inks, and is not absorbed by the paper fibre to the same extent. Writing-inks are generally acid in character, which causes the corrosion on metal pens; but this property rather tends to enhance the value of the ink, as it retards the bleaching action noticeable in old documents. Creasote, or common wood vinegar, is added to most inks to prevent moulding.

The following will be found excellent recipes for the manufacture of black writing-ink on a small scale: *With galls and sulphate of iron*.—1 lb. bruised galls, 1 gal. boiling water, 5½ oz. of sulphate of iron (copperas) in solution, 3 oz. gum-arabic, previously dissolved, and a few drops of an antiseptic, such as carbolic acid. Macerate the galls for twenty-four hours, strain the infusion, and add the other ingredients. *With Logwood*.—Boil 10 oz. logwood in 20 oz. of water; boil again in 20 oz. more water, and mix the two decoctions; add 2 oz. chrome alum, and boil again for quarter of an hour; and 1 oz. gum-arabic. The product is 25 oz. deep black ink.

Copying-inks are prepared by adding sugar, gum, or glycerine to ordinary writing-inks. These substances protect the colouring matter (combined with the iron) from the oxidising influences of the air, by forming a skin or impervious varnish over the writing. Thus, when the damp 'tissue' is pressed upon the writing, sufficient unoxidised ink is transferred to stain the paper from back to front, and expose a legible copy on the upper side. Aniline colours dissolved in water holding gum or sugar in solution are also used as copying fluids. Owing to their intense colouring power these inks are useful where many copies from one document are required, but only for temporary use, as on exposure to air or light these colours quickly fade, and the record is lost. Copyable printing-ink is prepared from these materials; and, when written and printed matter is to be copied, as on way-bills or invoices, its use is a great convenience. Copyable pencils are prepared from the same materials (in a solid form). But there is a very serious objection to the use of such inks and pencils: the printed or written matter can be entirely removed by means of alcohol or other solvents.

Many attempts have been made to produce writing-inks which would hinder or render impossible tampering with documents, but without much success. The necessity for such inks seems exaggerated, as it has been found that even with the best manipulative skill and chemical knowledge it is practically impossible wholly to remove writing produced with the common iron and tannin ink, such as is almost universally used.

Coloured Inks. These are essentially solutions of colouring matters. Red ink is best prepared by dissolving pure carmine in ammonia; blue, by dissolving Prussian blue in oxalic acid; green, by dissolving one per cent. methyl green in warm water. Other colours can also be simply prepared, but not being in demand are not usually met with in

commerce. The desirable properties in all writing-inks are that they shall flow freely and not gum or clog the pen, that they shall remain perfectly fluid (without depositing the colouring matter), and that they shall be reasonably permanent in character.

Sympathetic Inks.—These are of great variety, and although possessing an interest to the lover of the marvellous, are not in common use. When weak solutions of cobalt are used (chloride or nitrate), the writing remains invisible until the paper is heated; it then assumes a red colour, which on being exposed to damp air (or breathed upon) changes to green. Salts of lead or bismuth, on being treated with sulphuretted hydrogen, give a black impression. When a weak solution of galls or tannic acid is used the paper on being plunged into a bath of a per-salt of iron will show the characters in black. This is a useful method of restoring faded old writing, and in cases where chemicals have been used with the purpose of removing it.

Printing-ink.—This is a greasy or oily compound in which solid pigments are held in suspension, and is altogether different both in appearance and composition from the writing-inks we have described. It also is usually applied to paper surfaces, and amongst other qualities it must possess the property known to printers as 'distribution'—i.e. of being easily spread out in a layer, the tenacity of which will not cause it to fill up the interstices of and between the types; it must also attach itself to the paper when the type is pressed upon it, detaching itself from the latter entirely; it must possess the apparently opposite properties of drying on the paper within reasonable time, whilst it shall not do so on the type, rollers, or ink-tables; and lastly, it should be permanent in so far as the impressions on paper should have no tendency to change. The various qualities of printing-ink may be described under three heads—viz.: (1) newspaper inks; (2) bookwork inks; and (3) lithographic inks. With the common and consequently cheap printing-inks it is not necessary that the more expensive drying oils be employed as a vehicle or varnish for the colouring matter. Common oils made from paraffin and resin are used, mixed with ordinary lampblack. From this compound, when applied to the surface of printing paper, the oily matter is absorbed, leaving the colouring matter as a stain on the outside, which does not 'set off' to such an extent as to prevent its employment for cheap periodicals and newspapers. The better class of printing-inks, however, must actually dry upon the surface of the paper in the same manner as paint will dry when applied to a wall. This result is obtained by the employment of drying oils—that is, oils which have the property of absorbing oxygen and becoming gum-like or resinous in character. Thus, when the ink, prepared from linseed, poppy, or walnut oil, is exposed to the atmosphere, especially if assisted by heat, the colouring matter becomes imprisoned or varnished over with a resinous coating, which prevents it setting off or staining any substance brought in contact with it. In preparing the varnish of such inks the oils already mentioned are heated to 500 or 600 F., at which temperature they are kept for a period varying with the degree of viscosity or thickness of the varnish required. In this operation the oil (a compound of fatty acids with glycerine) gradually thickens, without much loss of colour or weight, pungent fumes of acrolein, due to the decomposition of the glycerine, being given off. The varnish so produced is mixed with lampblack, prepared either from coal or burning oil, or from the imperfect combustion of gas, and after very careful grinding is in a condition for use.

The manufacture of coloured inks is practically

much the same as for black inks, only great care must be exercised to secure the purity of the varnish, and to see that the chemicals employed do not react upon one another. For example, when vermilion (which is a compound of sulphur and mercury) is employed with colours containing iron or lead, the splendid colour of the vermilion is entirely destroyed by the formation of black sulphur compounds with the iron and lead. It is impossible in such an article to give more than the general outline of this manufacture, with which are connected many mysterious processes for which there is no chemical explanation. The technical manuals are said to contain reliable recipes to guide to its manufacture, and we must refer our readers to those for details. The chief drawback in regard to coloured printing-inks is their tendency to fade on exposure to the air and light. This drawback has become more accentuated since the introduction of coal-tar colours, with which it seems to be the rule that the more brilliant and beautiful they are the less are they fit to resist these destructive influences.

In lithography both writing and printing inks are employed, these being of a peculiar character. The former consists of a soapy fluid holding in suspension fatty matters (shellac, white wax, and tallow), which on being transferred to the stone are absorbed and retained by its porosity. The subsequent application of lithographic printing-ink (which is only the finest variety of printing-ink prepared in an especial manner) to the damp surface of the stone causes it to collect and form a layer on the portions which the lithographic writing-ink has penetrated. As in the case of letterpress-inks, those for lithographic purposes are prepared in black and coloured varieties.

Special inks are prepared for colotype and tinplate printing. Stamping or obliterating inks may either be prepared by thinning down black or coloured letterpress printing-inks with linseed-oil or turpentine, or by grinding aniline colours with glycerine and treacle.

Indian Ink or China Ink.—This is a mechanical mixture of the purest and densest lampblack, with a solution of gum, gelatine, or of agar-agar. The black paste is dried and pressed so as to form cakes, in which condition it is sold. The lampblack is prepared by burning sesame or other oils, controlling the supply of air so that in place of a clear flame the carbon from the burning oil is deposited in fine flakes in the form of lampblack. For the very finest varieties the material used for this purpose is camphor. The lampblack or carbon so produced is amorphous, and of an intensely black colour. In this condition it is seldom used for the purpose of ordinary writing, but when rubbed down with water forms a material used by draughtsmen for plans, &c. Inks of a similar nature can be prepared by mixing the solutions already mentioned with colouring matter.

Marking-ink.—When certain salts of silver or platinum are applied to textile fabrics these materials are reduced in the fibres of the fabric, and the writing so produced is not removed by the ordinary scouring process to which such articles are subjected. Aniline in the presence of oxidised substances also produces a useful indelible ink.

Ink-stains.—The removal of writing ink stains from linen is easily effected, by alternately dipping the parts in a solution of oxalic acid and hypochlorite of lime (or soda). If the stains be old and have assumed the brown colour of iron mould, warm diluted muriatic acid will be found effectual in their removal. Where the fabric is coloured the removal of ink stains is more difficult, as the chemicals employed in the former case are inadmissible. In this case a solution of pyrophosphate of

soda may be used with advantage, as this salt does not seriously affect even delicate colours. It is of course necessary to thoroughly wash the fabric after the removal of the stains.

Inkermann, a village in the Crimea, situated near the eastern extremity of the harbour of Sebastopol. See CRIMEAN WAR.

Inland Revenue. See EXCISE, TAXATION.

Inlaying is the art of decorating flat surfaces by the insertion of materials differing from the ground or body in which they are inlaid, in colour, texture, or other qualities. The body or basis may be wood, stone, or metal, and the inlaid or encrusted substances may be woods of various colours, ivory, mother-of-pearl, tortoiseshell, precious and other metals, marbles, and hard and precious stones, all these substances being selected principally on account of the brilliancy and variety of their colours. Inlaying in wood is known generally as *marquetry*; in metals the inlay principally practised is called *Damascening* (q.v.); and in marble and precious stones it forms a variety of *Mosaic-work* (q.v.). As is the case with most decorative arts, the origin of inlaying can be traced to eastern countries. While some kinds of inlays were known in ancient Rome, the art as practised in modern times first took root in Venice in the 15th century, when small caskets were ornamented with inlays of ivory and wood in strictly geometrical patterns, such as continue to be reproduced to this day in the familiar inlay-work of Bombay. Contemporaneously the Florentines began to ornament furniture, &c. with small inlaid dice of ivory arranged to form various patterns, and this style of inlay has since become generally known as *Certosa-work*, from the fact that the choir-fittings in the church of the Certosa or great Carthusian monastery, near Milan, are ornamented in this manner. From these beginnings developed the *Tarsia-work* of Italy of a century later, which, dealing at first with geometrical patterns in wood, developed into inlaid representations of architecture, views, figures, and drapery, and finally into foliaceous scrolls of modern marquetry. Marquetry-work in furniture was greatly elaborated in France, Germany, and Holland towards the close of the 17th century, and workers in wood found great delight in skilful elaboration of intricate designs. Towards the close of the 17th century a new development of marquetry was effected by a French artist, Charles André Boulle, in the exclusive use of inlaid veneers of tortoiseshell and brass, now known as *Buhl-work*. Both in design and execution Boulle's work was of remarkable quality; the colour of his tortoiseshell was frequently heightened by a backing of gold or vermilion, and his brass-work was enriched with skilful engraving. Towards the close of the 18th century, while marquetry of a most elaborate character was being made in Germany and Italy, the richest triumphs of the art were produced in France by the famous *ébénistes* Reiser and Roentgen; but the Revolution put an end for the time to the manufacture.

Pietra-duca, which consists of an inlay of bright-coloured, hard, and precious stones, in slabs of marble or in panels of wood, is allied to the ancient mosaic-work which flourished in the palmy days of Rome; but true mosaic, although embedded, is not inlaid. *Pietra-duca* began to be made in Italy in the 15th century, but its extreme costliness prevented its extensive application. Two varieties were made in Italy, one being an inlay of minute pieces of stones with colours so arranged as to form a design or picture, like mosaics of larger size. This is known as *Roman mosaic*, in contradistinction to *Florentine mosaic*, which consists of slices of

stone shaped and inserted to form definite portions of the required design. This latter class of inlaid-work was introduced into India by a French artist, Austin de Bordeaux, who decorated the famous Taj Mahal at Agra in pietra dura of the richest and most elaborate character. The art then took root in that region, and to this day pietra-dura of manifestly European character in design continues to be a characteristic art industry of Agra.

The ornamental treatment of metals by inlaying is principally confined to the encrusting and inlaying of wire and fine plates of gold and silver into iron, steel, and bronze. The inlaying of gold and, to a minor degree, silver wire into iron or steel is known as Damascening (q.v.). In India such damascening is known as Kuit-work, and extensively practised in the North-western Provinces. Effective combinations of inferior metals are also made in India; silver inlaid in a black alloy of copper, lead, and tin being known as Bidri-work, from Bidar, in the Deccan. Combinations of copper and brass, and of brass and tin, are also common in the household vessels of the Hindus. The Japanese, who possess many alloys, excel in combining and inlaying them, often in relief, in their art metal manufactures.

Inn (ancient *Enns*), a river of Germany, the most important Alpine alluvial of the Danube, rises in the south of the Swiss canton of Grisons, and flows north-east through the valley of the Engadine, and onwards through Tyrol and Bavaria, to its junction with the Danube at Passau in a stream (320 yards) broader than that of the Danube. Its total course is 317 miles. In Bavaria its bed is broad and sown with islands.

Inn is the legal designation of a house or hotel where lodging and refreshment are provided for travellers generally. Public houses, &c. are not properly described as inns unless some rooms are set apart for guests to lodge in. An inn may be set up without a license; but if excisable liquors are sold the innkeeper must take out a license; and even temperance hotels are made subject to police inspection, to prevent evasion of the law.

An innkeeper is bound to open his house to travellers generally; he may not refuse refreshment or lodging to any person who is able and willing to pay, unless such person is drunk or disorderly, or tainted with infectious disease. He is, of course, bound only to give such accommodation as he has. If the traveller has a horse and luggage the innkeeper is bound to receive them if he has accommodation, provided the traveller himself intends to lodge there as a guest. But the traveller is not entitled to select whatever room he pleases, and if he will not accept such reasonable accommodation as is offered, the innkeeper may order him to leave the house. An innkeeper has a lien or right to detain the horse, carriage, or goods of his guest for that part of the reckoning applicable to each respectively, and this lien he acquires even if the horse, &c. be not the property of the guest. He has no right to detain the person of his guest.

By the Roman law an innkeeper was bound to restore goods entrusted to him by his guests, unless they were lost by some *damnum fatale*, or inevitable misfortune; this was the effect of a clause in the edict beginning *Navata, carponea, stabularia*. The same rule was adopted by the English common law. Hence, if a guest was robbed of his goods at an inn the innkeeper was liable, unless the guest had taken upon himself the care of his own property, or the loss was due to the default or negligence of the guest himself, his servant, or companion; and the landlord was not permitted to escape liability by putting up a notice that he

would not be answerable for losses. But the Innkeepers Act, 1863, provides that an innkeeper shall not be liable to make good the loss of any goods, &c. (not being a horse or carriage) to a greater amount than £30, unless the loss has been occasioned by his own wilful default, or the property has been deposited with him for safe custody. A copy of the first section of the act must be exhibited in the hall or entrance to the inn. The liability of innkeepers in respect of goods belonging to their guests extends to all keepers of public-houses, &c., but not to persons who let lodgings. The keeper of a boarding-house or lodging-house is free from liability if he exercises ordinary care—i.e. such care as he takes of his own goods. The Innkeepers Act of 1878 permits a landlord (after giving notice as required by the act) to sell the property of a guest who has left without paying. In Scotland the Roman rule of law as to innkeepers' liability has been adopted, and the law is substantially the same as in England, except that no indictment would lie against an innkeeper for refusing a guest. See further, as to the licenses required by innkeepers, the articles LICENSING LAWS and LIQUOR LAWS.

Inmate Ideas. See COMMON SENSE, DESCARTES.

Inner House, the name given in Scotland to the higher divisions of the Court of Session (q.v.).

Inverleithen, a police-borough (1869) of Peebles-shire, near the Tweed's left bank, 6 miles ESE. of Peebles, and 12 W. of Galashiels. Its first woollen-factory was established in 1790, about which time its saline spring (Scott's 'St Roman's Well') came into celebrity; but the great extension of its woollen industry dates from fifty years later. Pop. (1841) 463; (1891) 2512.

Inver Temple, one of the Inns of Court (q.v.).

Innes, Cosmo, lawyer, antiquary, and historian, was born at Duns, on Deeside, 9th September 1798. His father, formerly the laird of Leuchars, was a scion of the old family of Innes of Innes. Cosmo was educated at the Edinburgh High School, and he graduated both at Glasgow and Oxford. In 1822 he passed as a Scottish advocate, became sheriff of Moray in 1840, and subsequently was appointed clerk to the Second Division of the Court of Session. In 1846 he was elected to the (unpaid) chair of History in the university of Edinburgh. Cosmo Innes is perhaps best known as the author of *Scotland in the Middle Ages* (1860), and *Sketches of Early Scotch History* (1861), but he also prepared the first volume of *Acts of the Scottish Parliament*, and at the time of his death was engaged on an index to the whole series. He was further a most industrious member of the Bannatyne, Maitland, and Spalding Clubs, and edited for them several of the register-books of the old religious houses of Scotland, with other historical documents of great importance. He published a volume of lectures on *Legal Antiquities* (1872), and was the author of several memoirs, including one of Dean Ramsay. Cosmo Innes died suddenly at Killin, 31st July 1874, in his seventy-sixth year. See the Memoir by his daughter, Mrs Hill Burton (1874).

Innes, Thomas, a Scottish historian, known better as 'Father Innes,' was born in 1662 at Drumgask, on Deeside, Aberdeenshire. At fifteen he was sent to Paris, where he studied at the College of Navarre and the Scots College, of which latter body his eldest brother Lewis (1651-1738) was principal from 1682. Thomas received priest's orders in 1692, and after three years of mission work at Invercayen, Banffshire (1698-1701), returned to Paris, and became prefect of studies in the Scots

College, where he died, 28th January 1744. To pursue his researches he had paid a visit or two to England and Scotland; and Wodrow, who saw him at Edinburgh in 1724, describes him as 'a monkish, bookish person, who meddles with nothing but literature.' Withal he was a staunch Jacobite, but no Ultramontane; not free, indeed, from suspicion of Jansenism. He may justly be looked on as the precursor of Niebuhr and Niebuhr's successors; for his *Critical Essay on the Ancient Inhabitants of Scotland* (2 vols. 1729) is much the earliest of all scientific histories. It was meant for an introduction to a *Civil and Ecclesiastical History of Scotland*, one volume of which, coming down to Columba's death, he prepared for the press, whilst another, bringing down the narrative to 831, was left incomplete. Both were edited for the Spalding Club by Dr Grub in 1853. The aim of the whole work was 'to counteract the inventions of former historians [Hector Boece], and to go to the bottom of the dark contrivances of factious men [George Buchanan] against the sovereignty of our kings;' and, though he thus wrote with a purpose, his honesty and acumen were such that the work retains a permanent value. See the Memoir by Dr Grub prefixed to the reprint of the *Critical Essay* ('Historians of Scotland' series, vol. viii. 1879).

Innocent, the name of thirteen popes, the most remarkable of whom are the following.—**INNOCENT I.**, a native of Albano, was elected Bishop of Rome in 402. Next to the pontificate of Leo the Great that of Innocent forms the most important epoch in the history of the relations of the see of Rome with the other churches, both of the East and of the West. He was earnest and vigorous in enforcing the celibacy of the clergy. He maintained with a firm hand the right of the Bishop of Rome to receive and to judge appeals from other churches, and his letters abound with assertions of universal jurisdiction, to which Catholics appeal as early evidence of the Roman primacy. Innocent I. died in 417, and was canonised.—For Innocent II. see **POPE, ANTIPOPE.**

INNOCENT III. (**LOTHARIO CONTI**), by far the greatest pope of this name, was born at Anagni in 1161. After a course of much distinction at Paris, Bologna, and Rome, he was made cardinal; and eventually in 1198 was elected, at the unprecedentedly early age of thirty-seven, a successor of Pope Celestine III. His pontificate is justly regarded as the culminating point of the temporal as well as the spiritual supremacy of the Roman see; under the impulse of his ardent but disinterested zeal for the glory of the church, almost every state and kingdom was brought into subjection. In Italy, during the minority of Frederick II., who was a ward of Innocent's, the authority of the pope within his own states was fully consolidated, and his influence among the other states of Italy was confirmed and extended. In Germany he adjudicated with authority upon the rival claims of Otto the Guelph and Philip of Swabia; in France he compelled Philip Augustus to dismiss Agnes de Meranie, whom he had unlawfully married, and to take back Ingeburga. In Spain he exercised a similar authority over the king of Leon. The history of his conflict with and triumph over John of England displays in a stronger light the extent of his pretensions and the completeness of his supremacy. Even the king of Armenia, Leo, received his legates. And, as if in order that nothing might be wanting to the completeness of his authority throughout the then known world, the Latin conquest of Constantinople and the establishment of the Latin kingdom of Jerusalem put an end, at least during his pontificate, to the shadowy pretensions of the eastern rivals of his

power, spiritual as well as temporal. His views of the absoluteness of the authority of the church within her own dominion were no less unbending than his notion of the universality of its extent. To him every offence against religion was a crime against society, and in his ideal Christian republic every heresy was a rebellion which it was the duty of the rulers to resist and repress. It was at his call, therefore, that the crusade against the Albigenses was organised and undertaken. As an ecclesiastical administrator Innocent holds a high place in his order. He was a vigorous guardian of public and private morality, a steady protector of the weak, zealous in the repression of simony and other abuses of the time. He prohibited the arbitrary multiplication of religious orders by private authority, but he lent all the force of his power and influence to the remarkable spiritual movement in which the two great orders, the Franciscan and the Dominican, had their origin. It was under him that the celebrated fourth Lateran Council was held in 1215. In the following year he was seized with his fatal illness, and died in July at Perugia at the early age of fifty-six. His works embrace sermons, a remarkable treatise on the *Misery of the Condition of Man*, and a large number of letters. The 'golden sequence' 'Veni, sancte Spiritus' has been attributed to him by some. It is from his letters and his decretals alone that the character of the age and the true significance of the church policy of this extraordinary man can be fully understood. However earnestly men may dissent from these views, no student of mediæval history will refuse to accept Dean Milman's verdict on the career of Innocent III. that 'his high and blameless, and, in some respects, wise and gentle character, seems to approach more nearly than any one of the whole succession of Roman bishops to the ideal light of a supreme pontiff;' and that 'in him, if ever, may seem to be realised the churchman's highest conception of a vicar of Christ.'

See Milman's *Latin Christianity*, vol. v.; Jorry's *Histoire du Pape Innocent III.* (1853); and the works in German by F. Hurter (1834-42), Deutsch (1876), Schwemer (1882), and Brisehar (1883).

INNOCENT XI. (**BENEDETTO ODESCALCHI**), born at Como in 1611 and elected in 1676, was one of the most distinguished among the popes of the 17th century. He was a vigorous and judicious reformer; but his historical celebrity is mainly owing to his contest with Louis XIV. The dispute began with an attempt on the part of the pope to put an end to the abuse of the king's keeping sees vacant, in virtue of what was called the *Droit de Regale*, and appropriating their revenues. The resistance to this attempt drew forth the celebrated declarations of the French clergy as to the Gallican Liberties. But the actual conflict regarded the immunities enjoyed by the foreign ambassadors residing in Rome, and especially the right of asylum, which they claimed not only for their own residences, but also for the adjoining district. These districts had gradually become so many nests of crime, and of fraud upon the revenue; and the pope gave notice that he would not thereafter receive the credentials of any new ambassador who should not renounce these abusive claims. The great powers murmured at this threat, but it was with France that the crisis occurred. Louis XIV. instructed his new ambassador to maintain the dignity of France, and sent a large body of military and naval officers to support his pretensions. Innocent persisted in refusing to grant an audience to the ambassador, Louis, in reprisal, seized on the papal territory of Avignon; but the pope was immovable, and the dispute was not adjusted till the following pontificate. Innocent died in 1689. The pope of Brown-

ing's *Ring and the Book* was Innocent XII. (Pignatelli), pope in 1691-1700.

Innocents, HOLY. See CHILDREMAN.

Innominate Artery (*Arteria innominata*) is the first large branch given off from the arch of the Aorta (q.v.).

Innominate Bone. See PELVIS.

Innsbruck, the capital of Tyrol, 100 miles by rail S. of Munich, stands on the Inn at its junction with the Sill, 1880 feet above sea-level, surrounded and overhung by mountains ranging from 7500 to 8500 feet high. It is a beautiful place, with broad tree-shaded streets, arcaded shops, and four squares adorned with statues. The Franciscan church, or Hoikirche, built in the Renaissance style in 1553-63, contains a beautiful and elaborate monument to the Emperor Maximilian I. (who, however, is buried in Vienna). It consists of a marble sarcophagus supporting the emperor's effigy in bronze, in a kneeling posture; while on both sides of the aisle are twenty-eight bronze figures of royal (mostly Hapsburg) personages, by Peter Vischer and other German artists. In the same church are monuments to Andreas Hofer and his comrades Speckbacher and Haspinger, and to the Tyrolese who fell in the wars against France (1796-1809). The parish church of St James has a picture of the Virgin by Lucas Cranach. The other chief buildings are the imperial castle, built by Maximilian I. and restored by Maria Theresa in 1766-70; the 'Golden Roof Palace'; the national museum, the Ferdinandenm.; and the university (founded in 1677, and, after several vicissitudes, organised anew in 1826), which has the usual four faculties and upwards of 800 students and 100 professors and lecturers. To the university are attached a library of 92,000 volumes, a botanical garden especially rich in Alpine flora, and the usual museums, laboratories, &c. Amongst the eight monasteries of Innsbruck is the first that the Capuchins founded in Germany (1594). Innsbruck carries on manufactures of woollen cloth, machines, and glass, and glass-painting. It is much visited by tourists in the summer. Pop. (1890) 23,320; or, including the suburbs of Hotting and Wilten, 35,800. Innsbruck has always been a place of some commercial importance, owing to its situation at the ford across the Inn and at the head of the Brenner Pass to Italy. The Romans had here their principal colony in Rhaetia. From 1180 the town belonged to the Counts of Meran; in 1363 it passed with Tyrol to Austria. The stormiest period of its history fell in the days of Hofer (q.v.). See Gwercber, *Innsbruck, and dessen Umgehung* (1880).

Inns of Court, the name given to certain voluntary societies which have the exclusive right of calling persons to the English bar. These societies had their origin in the 13th century, when the clergy ceased to practise in the law-courts, and their place was taken by lay professors, 'apprentices,' and students of law who congregated in the neighbourhood of Westminster. There are four Inns of Court—Lincoln's Inn, the Inner Temple, the Middle Temple, and Gray's Inn. Each possesses a dining-hall, library, and chapel, the Temple Church being used as a chapel by both the societies which take their name from the buildings which once belonged to the Knights Templars. Each inn derives a considerable income from houses and chambers occupied by barristers and others, and each is governed by an irresponsible body called the Benchers. New members of this body, who are usually judges or senior counsel, are chosen by the existing members. The inns possess equal privileges; since 1855, when a royal commission reported on their revenues and constitution, they

have joined in providing lectures for the benefit of students, and in examining candidates for admission to the bar. They have discretion to admit or refuse any candidate without assigning their reasons; but no objection is made to the admission of any person of good character. Each inn exercises discipline over its own members, and has power to disbar them—i.e. to withdraw from them the right to practise; but there is an appeal to the judges from the decision of the benchers. The right of disbarring is exercised only in the case of persons guilty of criminal offences or gross professional misconduct; a formal inquiry is held, but the results of the investigation are not made public. Serjeants' Inn was formerly a society composed of barristers and judges belonging to the 'order of the cof'; but this inn was abolished in 1877. The smaller societies, sometimes called Inns of Chancery, have never been of any great importance; their buildings have passed into the possession of one or other of the Inns of Court, or have become the property of small private societies of solicitors, &c. Staple Inn and Clement's Inn are interesting by reason of the collegiate character of their buildings. For further information, see the Report of the Commission of 1855. The steward of any of the Inns of Court will furnish intending candidates for the bar with information as to the terms of admission, &c. See BARRISTER, and Pease's *History of the Inns of Court* (1848).

The society known as the King's Inns in Dublin performs the duties of an Inn of Court in relation to the Irish bar. The Scottish bar is organised on an entirely different plan (see ADVOCATE).

Innuendo, a part of a pleading in cases of libel and slander, pointing out what and who was meant by the libellous matter or description.

Inoculation ('engrafting'), the communication of disease to a healthy subject by the introduction of a specific germ or animal poison into his system by puncture or otherwise, originally used of the inoculation of smallpox (for preventive inoculation, see BACTERIA, GERM, ANTHRAX, DIPHTHERIA, HYDROPHOBIA). If the matter of a smallpox pustule, taken after the commencement of the eighth day, be inserted in or beneath the skin of a person who has not previously suffered from smallpox, the following phenomena are induced: (1) Local inflammation is set up; (2) on the seventh or eighth day there is fever similar to that of smallpox; and (3) after the lapse of three more days there is a more or less abundant eruption of pustules. This process is termed inoculation, and the disease thus produced is denominated inoculated smallpox. The disease produced in this artificial manner is much simpler and less dangerous than ordinary smallpox; and as it was an almost certain means of preventing a subsequent attack of the ordinary disease, inoculation was much practised till it was superseded in the beginning of this century by Jenner's introduction of vaccination. The importance of inoculation was recognised in the East at a very early period, the Chinese practising it from the 6th century, and the Brahmins from a very remote antiquity. In Persia, Armenia, and Georgia it was in use, and it is even said to have been employed in Scotland and Wales. It was not, however, till Lady Mary Wortley Montagu wrote her celebrated letter from Adrianople in 1717 that the operation became generally known in England. In that letter she writes: 'The smallpox, so fatal and so general amongst us, is here entirely harmless, by the invention of *ingrafting*, which is the term they give it. Every year thousands undergo the operation. There is no example of any one that has died in it, and you may believe that I am very well

satisfied of the safety of the experiment, since I intend to try it on my dear little son.' Four years afterwards she had her daughter publicly inoculated in England; the experiment was then performed successfully on six condemned criminals at Newgate, and on the strength of these successful cases two children of Caroline, Princess of Wales, were inoculated, which gave a sanction to the practice.

Inoculation was not, however, thoroughly established for more than a quarter of a century after its introduction. It met with virulent opposition both from the medical profession and the clergy. A sermon is extant which was preached in 1722, by the Rev. Edward Massey, in which it is asserted that 'Job's distemper was confluent smallpox, and that he had been inoculated by the devil.' The great drawback to inoculation turned out, however, to be this: while it was invaluable to him who underwent the operation, and completely guarded him from the natural disease in its severe form, its effect upon the community at large was extremely pernicious in keeping alive the natural disease, and increasing its spread amongst those who were not protected by inoculation. While one in five or six of those who took the natural disease died, the average number of deaths at the Inoculation Hospital was only 3 in 1000; and yet, according to the authority of Heberden, in every thousand deaths within the bills of mortality in the first thirty years of the 18th century (before inoculation was at all general) only seventy-four were due to smallpox. The deaths from this disease amounted to 95 in 1000 during the last thirty years of the century; so that, notwithstanding the preservative effects of inoculation on almost all who were operated on, the total number of deaths from this disease increased in one hundred years in the ratio of about 5 to 4. At the beginning of the 18th century about one-fourteenth of the population died of smallpox; whereas at the latter end of the same century the number (notwithstanding, or perhaps rather in consequence of, inoculation) had increased to one-tenth; and this immense consumption of human lives was not the total evil, for many survivors were left with the partial or entire loss of sight and with constitutions destroyed. The benefits which were expected from inoculation were far from being realised, and smallpox would doubtless have gone on increasing in its destructive power if it had not been checked by Jenner's discovery of Vaccination (q.v.). Inoculation was forbidden by law in 1840.

Inowracław, called also **JUNG BRESLAW** ('Young Breslau'), a town of Prussia, is situated near the Polish frontier, 66 miles N.E. of Posen. Its chief industries are salt mining, the manufacture of salt and machines, and iron-founding. Pop. (1875) 9139; (1885) 13,548.

In partibus infidelium (Lat., 'in the regions of the unbelievers'). Titular bishops in the Church of Rome were from the 13th century until the pontificate of Leo XIII. styled bishops *in partibus infidelium*. They were originally bishops who had no diocese, and took their titles from places where there was no longer a bishop's see. The usage originated after the Greek schism, and became general in the time of the Crusades. The places conquered by the crusaders in the East were furnished with Roman Catholic bishops; but when these conquests were again lost the popes continued to appoint and consecrate the bishops as a continual protest against the power which had prevailed over their alleged right, and to signify their hope of restitution. But in Britain, the assumption of territorial titles being illegal and dangerous, the Roman Catholic bishops actu-

ally resident long bore titles derived from such distant places. In 1850 their assumption of titles from their actual sees gave prodigious offence in England, and led to the passing of the *Ecclesiastical Titles Bill* (q.v.), which, however, remained a dead letter, and was repealed in 1871.

Inquest. See CORONER.

Inquisition, called also 'the Holy Office,' a tribunal in the Roman Catholic Church for the discovery, repression, and punishment of heresy, unbelief, and other offences against religion. From the very first establishment of Christianity as the religion of the Roman empire laws more or less severe existed, as in most of the ancient religions, for the repression and punishment of dissent from the national creed; and the emperors Theodosius and Justinian appointed officials called 'inquisitors,' whose special duty it was to discover and to prosecute before the civil tribunals offences of this class. The ecclesiastical cognisance of heresy and its punishment by spiritual censures belonged to the bishop or the episcopal synod; but no special machinery for the purpose was devised until the spread in the 11th and 12th centuries of certain sects, reputed dangerous alike to the state and to the church—the Cathari, Waldenses, and Albigenses—excited the alarm of the civil as well as of the ecclesiastical authorities. In the then condition of the public mind, however differently it is now constituted, heresy was regarded as a crime against the state, no less than against the church. An extraordinary commission was sent by Pope Innocent III. into the south of France to aid the local authorities in checking the spread of the Albigensian heresy. The fourth Lateran Council (1215) earnestly impressed both on bishops and magistrates the necessity of increased vigilance against heresy; and a council held at Toulouse directed that in each parish the priest and two or three laymen of good repute should be appointed to examine and report to the bishop all such offences discovered within the district.

So far, however, there was no *permanant* court distinct from those of the bishops; but under Innocent IV., in 1248, a special tribunal for the purpose was instituted, the chief direction of which was vested in the then recently-established Dominican Order. The Inquisition thus constituted became a general instead of as previously a local tribunal; and it was introduced in succession into Italy, Spain, Germany, and the southern provinces of France. So long, moreover, as this constitution remained it must be regarded as a strictly papal tribunal. Accordingly, over the French and German Inquisition of the following century the popes exercised full authority, receiving appeals against the rigour of local tribunals, and censuring or even depriving the inquisitor for undue severity. In France the Inquisition was discontinued under Philip the Fair; and though an attempt was made under Henry II. to revive it against the Huguenots the effort was unsuccessful. In Germany, on the appearance of the Beghards (q.v.) in the beginning of the 14th century, the Inquisition came into active operation, and inquisitors for Germany were named at intervals by various popes, as Urban V., Gregory XI., Boniface IX., Innocent VIII., down to the Reformation, when it fell into disuse. In England it was never received, all the proceedings against heresy being reserved to the ordinary tribunals. In Poland, though established in 1327, it had but a brief existence.

It is the history of the Inquisition as it existed in Spain, Portugal, and their dependencies that has absorbed almost entirely the real interest of

this painful subject. As an ordinary tribunal similar to those of other countries it had existed in Spain from an early period. Its functions, however, in these times were little more than nominal; but early in the reign of Ferdinand and Isabella, in consequence of the alarms created by the alleged discovery of a plot among the Jews and the Jewish converts—who had been required either to emigrate or to conform to Christianity—to overthrow the government, an application was made to the pope, Sixtus IV., to permit its reorganisation (1478); but in reviving the tribunal the crown assumed to itself the right of appointing the inquisitors, and, in truth, of controlling the entire action of the tribunal. From this date forwards Catholic writers regard the Spanish Inquisition as a state-tribunal, a character which is recognised by Ranke, Guizot, Leo, and even the great anti-papal authority Llorente; and in dissociating the church generally and the Roman see itself from that state-tribunal, Catholics refer to the bulls of the pope, Sixtus IV., protesting against it. Notwithstanding this protest, however, the Spanish crown maintained its assumption. Inquisitors were appointed, and in 1483 the tribunal commenced its terrible career under Thomas de Torquemada. The popes, feeling their protest unsuccessful, were compelled from considerations of prudence to tolerate what they were powerless to suppress; but several papal enactments are enumerated by Catholics, the object of which was to control the arbitrary action of the tribunal and to mitigate the rigour and injustice of its proceedings. Unhappily these measures were ineffective to control the fanatical activity of the local judges. The number of victims, as stated by Llorente, the popular historian of the Inquisition, is positively appalling. He affirms that during the sixteen years of Torquemada's tenure of office nearly 9000 were condemned to the flames. The second head of the Inquisition, Diego Deza, in eight years, according to the same writer, put above 1600 to a similar death; and so for the other successive inquisitors-general. But Catholics loudly protest against the credibility of these fearful allegations. It is impossible not to see that Llorente was a violent partisan; and it is alleged that in his work on the Basque Provinces he had already proved himself a venal and unscrupulous fabricator. Although, therefore, he has made it impossible to disprove his accuracy by appealing to the original papers, which he himself destroyed, yet his Catholic critics—as Hefele in his *Life of Cardinal Ximenes*—have produced from his own work many examples of contradictory and exaggerated statements; Prescott, in his *Ferdinand and Isabella* (iii. 467-70), has pointed out many similar instances; and Ranke does not hesitate (*Fürsten und Völker von Süd-europa*, i. 212) to impeach his honesty. Still, with all the deductions which it is possible to make, the working of the Inquisition in Spain and in its dependencies even in the New World involves an amount of cruelty which it is impossible to contemplate without horror. When it was attempted to introduce it into Naples Pope Paul III., in 1546, exhorted the Neapolitans to resist its introduction, 'because it was excessively severe and refused to moderate its rigour by the example of the Roman tribunal' (Llorente, ii. 147). Pius IV. in 1563 addressed a similar exhortation on the same ground to the Milanese (*ibid.*, ii. 237); and even the most bigoted Catholics unanimously confess and repudiate the barbarities which dishonoured religion by assuming its semblance and its name.

The procedure of the Inquisition deserves a brief notice. The party, if suspected of heresy,

or denounced as guilty, was liable to be arrested and detained in prison, only to be brought to trial when it might seem fit to his judges. The proceedings were conducted secretly. He was not confronted with his accusers, nor were their names even then made known to him. The evidence of an accomplice was admissible, and the accused himself was liable to be put to the torture in order to extort a confession of his guilt. The punishments to which, if found guilty, he was liable were death by fire, as exemplified in the terrible *Auto da Fé* (q.v.), or on the scaffold, imprisonment in the galleys for life or for a limited period, forfeiture of property, civil infamy, and, in minor cases, retraction and public penance. It is fair to recollect that some of the usages were but the ordinary procedures in all the courts of the age, whether civil or ecclesiastical.

The rigour of the Spanish Inquisition abated in the later part of the 17th century. In the reign of Charles III. it was forbidden to punish capitally without the royal warrant; and in 1770 the royal authority was required as a condition even for an arrest. From 1808, under King Joseph Bonaparte, the Inquisition was suppressed until the Restoration; it was again suppressed on the establishment of the constitution of 1820; but it was partially restored in 1825; nor was it till 1834 and 1835 that it was finally abolished in Spain, its property being applied to the liquidation of the national debt.

The Inquisition was established in Portugal in 1557, and its jurisdiction was extended to the Portuguese colonies in India. The rigour of its processes, however, was much mitigated in the 18th century, and under John VI. it fell altogether into disuse.

The Inquisition in Rome and the Papal States never ceased, from the time of its establishment, to exercise a severe and watchful control over heresy, or the suspicion of heresy, which offence was punished by imprisonment and civil disabilities; but of capital sentences for heresy the history of the Roman Inquisition presents few instances, and, according to Balmez (*On Civilisation*, p. 156), that tribunal 'has never been known to order the execution of a capital sentence for the crime of heresy. The tribunal still exists under the direction of a congregation, but its action is confined to the examination of books and the trial of ecclesiastical offences and questions of church law; and since the Italian occupation of Rome in 1870 its supreme jurisdiction is limited to the Vatican.

See Llorente's *Historia Crítica de la Inquisición* (Fr. trans. 4 vols. 1817); Comte Joseph de Maistre's *Letters on the Spanish Inquisition* (Eng. trans. 1851); Prescott's *Ferdinand and Isabella*; Motley's works; Hefele's *Cardinal Ximenes*; Balmez, *Catholicism and Protestantism*; Hofman, *Geschichte der Inquisition* (1878); Mohner, *L'Inquisition double moti de la France au XIII. et au XIV. Siècle* (1880); H. C. Lea's *History of the Inquisition of the Middle Ages* (3 vols. 1888).

Insanity. No good definition of insanity has ever been given in any language, nor is it possible. Any definition that would have accurately fitted what was understood as insanity in Shakespeare's time would be quite inadequate now, for we count men insane who would have passed muster well enough in the 16th century. Another difficulty of definition consists in this, that the very same mental symptoms may exist in two people, and in one they may constitute true insanity, while in the other they may only be one of the brain symptoms of a fever. And if there is one thing better understood about insanity now than formerly, it is that there is no exact line of demarcation between insanity and sanity any more than there is between

light and darkness. There is an undefined borderland through which most cases of insanity pass, between technical and legal sanity and insanity. But while this is true, there is no truth and little sense in the common saying that 'all are more or less insane on some point.' Such a statement entirely mistakes the real significance of insanity as a *disease*, and is a pernicious fallacy begotten of ignorance. Insanity may be reasonably described, according to the scientific ideas of our time, as 'such an alteration in any or all of the mental functions of the brain as makes a man unfit from this cause to do his work or manage his affairs, or mingle in the society of his fellow-men, or which makes him unsafe to himself or others or to society, this alteration not being solely the result of fever, but being the result of disease or disorder in the working of, or imperfection in the development of that portion of the brain through which mind is manifested.' In defining or describing insanity we wish to exclude the delirium of fevers, comatose conditions, somnambulism, mere eccentricity, hysteria, transitory brain excitements due to religious or other strong emotions, or due to other adequate causes. A mother who loses control over herself when she hears suddenly that a child is dead may be more sane than another who shows no outward sign of emotion on such an occasion.

Tests.—There is or can be no absolute test of insanity—or of sanity, for that matter. Sanity is best proved by normal self-control, and insanity by the loss of it from disease. The presence of one or more insane delusions was at one time the legal test, but it is not a true or scientific one. The 'knowledge of right and wrong' was at one time a legal test of responsibility, in other words of sanity, by the law, but it has long been given up. Half the lunatics know right from wrong in some degree or other.

Mind and Brain.—Insanity cannot be properly studied or in any degree understood except by reference to the mental functions of the brain. A physiological view of mind can alone throw light on the complicated and wondrous phenomena of this disease. No merely metaphysical or subjective view or study of mind seems to help us in the least as to it; the facts are inexplicable on any such view of mind. Looked at from the human and social point of view, no other disease approaches it in the terror it inspires, the sense of helplessness it causes, the deep distress to relatives, and the disruption of all normal social conditions. A scientific view of it alone brings us into the mental and emotional attitude with which civilised humanity now regards disease in general. No progress was made in its study or treatment till physicians came to look at it in precisely the same way as they do ordinary disease. Mind must be regarded by all students of insanity practically as being a 'brain function' which is found in all animals in varying degrees; which in man does not at one time of life exist at all, then is seen to arise in small beginnings like any other function, then gradually to develop, attain maturity, and then fail and eventually disappear—all these conditions of mind being absolutely correlated with the structural development and decay of the mental organ in the brain. It is thus studied and looked on as sensation and motion are studied. The latest physiological and evolutionary studies of mind in relation to brain seem to lead to the conclusion on scientific and not merely *a priori* grounds that it is to the mental organ or centres in the brain that all higher evolution tends. In it are 'represented' every other organ and function of the body, and so they are all in intimate and organic connection with it and its highest function of mind, and so with each other as to make of the organism an

organic unity. If the evolutionists are right, everything that lives tends towards mentalisation, and all the nervous organs of all the types of animal life find their acme in the mental centres of the human brain. The whole of the human brain is not a mental organ. There are centres for motion and sensation and regulation of function, but they are all represented in, and correlated and largely controlled by the mental organ. It clearly resides in the convolutions of the brain. This dominant organ has necessarily become what it is in man through the hereditary influences that have gradually upbuilt it since the beginning of life. This heredity has been largely influenced by external conditions. These have been good and bad throughout the ages, and the bad have left many bad mental results, in so far as natural selection and the struggle for existence have not eradicated them. The mental organ in the human brain has thus become the most complicated, the most delicate, and yet the most potent thing in nature, impressionable to all stimuli from within the body and outside it; reactive in due amount, and yet not unduly if healthy, to all these impressions and stimuli; containing within itself, in a way that yet we are not even able to realise, hereditary qualities, bad and good, from thousands of ancestors. If this is so one is prepared to believe that through evil hereditary influences, and from evil conditions outside it, this organ may often be upset in its normal working. The most important form of such upset is insanity, because it touches the highest brain function. The student of mind physiologically finds on the threshold of his studies that every form of mental energy is just as hereditary as the colour of the hair or the shape of the nose; he finds that volitional power, reasoning acuteness, emotional keenness, moral sensitiveness, good social instincts, retentive memory, and mental resistiveness of all kinds are all transmitted hereditarily. He is therefore prepared to believe that these same laws of heredity have determined the volitional paralysis, the reasoning and the emotional perversions, the losses of memory, and the mental instability which he finds among the insane, and to believe that it is probably the most hereditary of all diseases.

General Symptoms.—The symptoms of insanity are best studied as mental and bodily symptoms. It is only since the disease was studied from the physician's point of view that the bodily symptoms have been specially noticed. Nothing in medicine was ever seen till it was looked for. Nowadays every physician knows that the bodily symptoms and the general condition of the body and its organs are often the most important matters for him to observe and attend to in a case of insanity. He finds few cases of recent insanity without such bodily symptoms. The most common mental symptoms are morbid emotional depression and mental pain, which is the dominant symptom in melancholia. It is an essential law of life that in health the performance of all function yields pleasure. The law is that to live is to energeise, and to energeise is to enjoy life. Except this is so there is abnormality or disease. In many cases of insanity to energeise mentally is to suffer pain. The essential relationship between emotion and action is thus reversed. Another symptom in other cases is an undue emotional exaltation; this is commonly associated with a loss of the great controlling or inhibitory functions of the brain, and occurs in mania. There is morbid brain excitement, commonly exhibited in restless motions or shouting. Such cases may go on to complete loss of any consciousness of all the former brain impressions and mental life. The patient remembers nothing, and does not know his nearest friends. Another most

common symptom is a diminution or loss in the power of attention. This is common to nearly all forms of insanity. Then we have perversion of the reasoning power, as seen most frequently in insane delusions. Like insanity, an insane delusion cannot be defined. It may be said to be a belief in something that would be incredible to ordinary people of the same class, education, or race as the person who expresses it, this resulting from some morbid state of the brain. Insane delusions are common in most cases and varieties of insanity. They are divided into fixed delusions and changing delusions, the former being the most serious and incurable. Some delusions are held by patients in a sort of slack theoretical way, not influencing conduct; others again are keenly held and lead to their logical results in conduct. There may be two 'prophets of the Lord' in an asylum, one of whom will insist on delivering his 'message' on every opportunity to all with whom he comes into contact, will not employ himself in ordinary occupations, and refrains from all amusement; the other will only speak of his delusion when asked about it, will be a capital blacksmith or scrubber of floors, and enjoy thoroughly a dance or a comic song. The origin of insane delusions is one of the most interesting, and often the most obscure of psychological problems. In some cases the process can be clearly traced, being analogous to the process of 'day dreaming' in children. Imagination and fancy are vivid, the reasoning and comparing power is in abeyance, and so the subjective is taken for the objective. Every time a fancy is so looked on it gets more and more 'organised' into a real delusion. Sometimes delusions result from the accentuation of the natural mental temperament by outward circumstances—e.g. when a hunchback of a naturally sensitive, suspicious disposition is in his boyhood annoyed by his fellow-boys at school, the consciousness of his deformity being thus ever brought before him, and when weak health and lack of physical power make him irritable and misanthropic and he then takes a fever, during which he is delirious, and fancies all the time that he hears the old boy-voices of opprobrium—it seems intelligible in such a case that after recovery, but with still a bloodless and weakened brain, he should still hear the voices saying 'hunchback, hunchback.' The hearing of voices when no such exist is an example of a *hallucination*, which is used to denote special sense impressions that have no outward causes. Hallucinations may be of hearing, which are the most common and the most serious as a symptom of incurability if long continued; of sight, the next most common and more likely to be recovered from; of smell and taste, which are rare, and not favourable. Hallucinations and delusions are often connected with and arise out of real sensations, which are misinterpreted by the weakened brain—e.g. a man has been drinking, and has so disordered his stomach, and irritated its lining membrane, that he feels a constant pain there and a bad taste in his mouth, and he concludes that poison has been put into his food, adding these real sensations as proof of his delusion. His mental centre had been disturbed in its working by the drink, so that he could no longer reason clearly and put the true interpretation on the facts.

A distinctive character of an insane delusion is that it cannot be in any way changed or dispelled by the clearest demonstration that it is false. A man thinks he is ruined and a pauper; you bring his bank book and show him that he has £1000 on his account; and you bring the banker with the actual money to him, but you cannot by such means eradicate the false belief. A sane man may have a hallucination (see HALLUCINATIONS), but he knows his 'brain is playing him

a trick,' when ordinary means are taken to demonstrate the unreality of his impression. Another very important and most dangerous symptom in insanity is the tendency towards suicide. This is commonly a symptom in melancholia, and usually goes with a depressed emotional state. But sometimes it exists by itself as a morbid impulse, unreasoning, unaccounted for, unexplainable. Sometimes patients attempt their lives when unconscious of what they are doing, and do not remember what they have done. Patients say that ideas of suicide come into their minds unsuggested in the midst of work and even of enjoyment. A desire to put an end to one's own life is physiologically the furthest away from health of any morbid mental symptom that can possibly occur, for it is a perversion of the primary instinct of all living beings—viz. the love of life, and the desire and effort to protect and preserve it. Without this instinct life would soon end on the earth. It is not any reasoning as to the desirability of life that keeps men and animals alive and drives to unceasing efforts to preserve it, nor is it the pleasure of eating, nor the fear of pain in death. It is the simple innate organic instinct to live which no reasoning can impair in most men. When a man attempts his life, apparently as a calm reasoning conclusion from facts which seem to prove that this is the best thing he can do, in ninety-nine cases out of a hundred the process of reasoning is not the real motive for the act, but the loss of the life instinct which started the reasoning and made the act possible. No doubt the strength of the instinct and of the love of life is much less in some persons and in some races apparently than in others. But such a lessened instinct means a bad heredity and lessened capacity for the struggle for existence. It is twin-brother to a heredity towards ordinary insanity. There may be motives that with civilised men are stronger even than the love of life, and a man with a strong will or under the impulsion of a strong emotion or in a state of despair may certainly take his own life though sane. Suicide is frequently suggested by the sight of the means of self-destruction. There are many persons not insane who cannot see a sharp weapon or go near a precipice without the suggestion of suicide, while many of the insane are entirely unable to resist attempts on their own lives when such means are seen. Some patients will use the utmost cunning to conceal their intention of committing suicide, whilst others will do it most openly. The natural courage of the person comes in very strongly in estimating the actual risk in any case; but the most timid, the most conscientious, who intellectually know it to be wrong, and see that every rational motive goes against it, the most affectionate, who know the terrible anguish it will cause to those they love, the most religious, who fear eternal damnation as its consequence, all equally commit suicide when suffering from insanity with the suicidal impulse. About 1700 persons actually take away their own lives every year in England, the proportion being much higher in some other countries. Alcohol is responsible for very many suicides every year. The same patient very often sticks to the same methods of committing suicide. He will again and again try to hang or poison himself when he has plenty of better chances of cutting his throat. The following are the common methods of suicide in Great Britain in their order of frequency—viz. drowning, hanging, starvation, wounds by firearms, poisoning, precipitation, and choking. But some patients prepare elaborate means and apparatus for the purpose. An American killed himself with a complicated apparatus worked by clockwork, which first put him under chloroform

and then decapitated him; this apparatus having taken him over two years to construct. Suicidal feeling or impulse is often recovered from, and is not a specially bad symptom except as requiring the watching of the patient.

Another mental symptom of insanity very common is impulsiveness, or action in an automatic unreasoning way, sometimes without any conscious intention on the patient's part, and without power of control by the will. A man sees a large plate-glass window, and he hurls a stone through it impulsively. Another cannot resist the impulse to tear his clothes, a third cannot resist the impulse to set a haystack on fire. Uncontrollable impulse naturally goes with diminished volition in insanity. What would be the conduct of most sane men if their wills did not stand between impulse and action? If the will is paralysed, as it is in many cases from disease, their impulse is uncontrolled. Patients may be fully conscious of morbid impulses, may intellectually see their danger or absurdity, and morally may deplore their 'wickedness' in yielding to them, yet have no power to control them; or they may be in a condition of unconsciousness, or false consciousness, during which impulsive acts are done and not remembered afterwards at all. When consciousness returns such people are surprised and incredulous when told that they have smashed furniture or tried to kill their children. A patient once attempted her own life, suddenly smashed a picture, and nearly strangled her attendant, and was amazed when told what she had done. She was a gentle, religious lady of the highest principle. Whenever she passed into this condition of false consciousness during which such impulsive acts were done she would glare at one particular picture on the wall, and would spring at it, so that it had to be removed from the room. She had no particular feeling about it when in her ordinary state of consciousness.

One of the most common and most painful symptoms of insanity is a change of natural affection towards relatives. The mother forgets her sucking child; the sister ceases to love the brother; and the husband dislikes or suspects his wedded wife. This is not universal, but in nearly half the cases of insanity the affective condition is thus perverted or reversed. The memory is not necessarily affected in insanity. In many patients it is exaggerated: things come back with unnatural vividness. A man during simple mania could repeat most of the Psalms and many of Shakespeare's plays, which he never could when well. In some cases the memory brings back only the unpleasantnesses of past life, in others only the pleasant events, and in others there is no memory of past events at all during the attack. It is a constant source of anxiety to relatives whether patients remember the events that have taken place during their attack or their own sayings, feelings, or thoughts then. No rule can be laid down as to this. It depends on the nature of the attack, and especially on whether the power of attention is affected during its continuance. It is certain the memory of events that happened during the attack is usually blurred or distorted or hazy, even though as in some cases the patients affirm they 'can remember everything.' It is frequent that after recovery they speak of the events during the attack and their own feelings then 'as if it were a dream.' Sometimes the affective nature gets changed during an attack not only in regard to persons, but to books, scenery, and food. The appetites become perverted and changed; the social instincts are commonly altered. In a few cases these are intensified, but their usual discrimination is lost. Commonly, a lunatic is unsocial, and some cases are entirely asocial. The

imaginative faculty is usually perverted, this being generally connected with the delusions present. In some cases an attack of insanity is a prolonged 'day-dream,' the condition being one rather of disjointed fancy than of coherent or constructive imagination. The normal law of association of ideas is usually altered. The same ideas do not suggest each other in sanity and insanity. The tendency is in insanity for ideas to suggest grotesque and incongruous things or trains of thought. The habits of life are notably changed in most cases, men and women becoming literally 'not themselves' in their ways and modes of living. The cleanly becomes uncleanly; the orderly man disorderly.

The chief bodily symptoms in insanity are the following. There is scarcely any symptom more common before and in the early stages of attacks than sleeplessness. 'Tired nature's sweet restorer, balmy sleep,' certainly departs when the terrible brain disturbance occurs, or is about to occur. It does not follow that because a man is sleepless he is going to be insane, but almost every kind of insanity is sleepless in its early stages. Nor does it by any means follow that sleeplessness is always the cause of the attack. It is rather in most cases an early symptom. The next bodily symptom in importance is morbidnesses of speech. On the patient's speech we chiefly depend for our diagnosis of most cases. Through it delusions are given expression to; it may be incoherent or partially coherent; it may be over rapid, slow, or entirely absent. A patient at Morningside Asylum never uttered a word for seventeen years, though he could speak quite well but for a delusion he has, and he works well, writes to express his wishes, goes out every Saturday and sees the sights of the town, and behaves mostly like a sane man, save in this particular. Often the conventionalities of speech are lost or dropped in insanity. The articulation of words is often changed. Next in importance to the speech is the expression of the face and eyes. This is given by the most delicate combined muscular and nervous apparatus that exists in nature, being in the most intimate connection with the mental part of the brain, and acting as its chief expositor and interpreter. It would be impossible to describe all the changes that take place in the expression of the eyes and faces of the insane. In the depressed and demented cases the eye loses its lustre and brilliancy; in maniacal cases it has abnormal feverish brilliancy; the pupil enlarging and the eyelids being drawn too far apart produce staring, the whole of the cornea being seen. In regard to the expression of the face, we see how the 'mind muscles' alter the man when in action and repose, in health and sickness. The natural expression is greatly changed, and little beauty of feature survives during acute attacks. The conventional control over the outward expression of the emotions is lost, and the face accurately shows the state of the melancholic, the maniacal, or the demented patient. Often too the fixed delusion shows in the patient's face. Indeed there are many cases where the expression caused by changed emotion during the first part of an attack gets fixed, and remains so after the patient has really ceased to feel the morbid emotion at all. A lady who had been intensely melancholy in feeling for five years then sank into incurable weakness of mind, and completely lost her keen feeling and memory, but for the next twenty years, till her death, the muscles of her face and her attitude expressed the melancholy which she did not feel. She constantly wrung her hands, and could not tell why she did so. There was in fact an automatic 'muscular misery.' There are important indications of certain kinds of insanity in the state of the pupils too,

In the muscular movements of the body an insane patient will often indicate his emotions far more than a sane man would do.

The skin, the hair, the perspiration, the liver, the heart, and the kidneys are often changed in working, and the temperature of the body altered during an acute or recent attack of insanity. Before an attack there are often pains or uneasy feelings in the head, which disappear when it comes on. The bodily sensations are notably dulled in most acute attacks. Patients will often cut or bruise themselves or undergo operations without feelings of pain. The body weight is rapidly lost, and the general nutrition almost invariably suffers. Thus it is seen that disease cannot attack the highest organ and function without affecting also almost every other organ and function of the body. The higher brain centres and the peripheral organs act and react on each other, so that when the one is disturbed in action the others suffer.

Forms, Varieties, and Classification of Insanity.—One case of insanity may differ from another in all its symptoms, mental and bodily, so that the two may have almost nothing in common except that in both the mind is affected from brain disorder. One case may be so near sanity that it needs an expert to say there is anything wrong; while another is 'raving mad' to any eye. One case is conscious that his mind is affected; another, much worse, believes he was never so well in his life. One case needs no control, and can do some work; another needs the control of others in all respects, and cannot do anything. One is perfectly safe to himself and others, while another is as dangerous as the popular 'madman' is supposed to be—as a matter of fact, half the insane are not dangerous at all, and very few of them are as dangerous as they are popularly supposed to be. The popular idea that the insane are all much alike is utterly wrong. Nothing is more common than for the doctor of an asylum to be asked such questions as—'Do your patients know where they are?' 'Are they the better for the visits of friends?' 'Do they enjoy each other's society?' 'Are they happy?' 'Do they like or dislike you?' 'Are they nice to do with?' To one and all of such questions the answer has to be—'They differ entirely from each other in all these respects.' Where there are differences it is the business of science to classify. Insanity has been classified most variously, but at the present time only two of the classifications can be said to hold the field. The one is that in which the prevailing mental symptoms are taken as the basis of classification, the cases with similar mental symptoms being thrown together into each group. This was first done by Philippe Pinel, who was born in 1745 and died in 1826, was the physician to the great hospital for the insane at Paris, the Bicêtre, and who during the revolutionary period asked and got permission to remove the chains and manacles from his patients there. It is the 'mental classification,' and is used more or less by all physicians. The other classification was that devised by David Skae, who was born in 1814 and died in 1873, and was physician to the Royal Edinburgh Asylum for twenty seven years, exercising during that time an enormous influence on the growth of the mental department of medicine, which is called 'alienism' in France, 'psychiatric' in Germany, and commonly medico-psychology in Britain. The 'clinical classification' goes on the principle of selecting a more real, natural, and lasting relationship between the cases than mere mental symptoms. The weak point of the mental classification is that it is one of symptoms only; and a case may change entirely in its symptoms in the course of the same attack. The weak point in the

clinical classification is that it does not cover the whole ground, many cases not being as yet classifiable under any of its divisions. The classification of the future will be a pathological one, which will supersede the two others, but our knowledge of the pathology of the various forms of insanity is not as yet sufficiently accurate to enable such a classification to be made. The forms of insanity under the mental classification, as found in Clouston's *Clinical Lectures on Mental Diseases* (1887), are as follows:

Melancholia, comprising all *states of depression*.—This has emotional depression, or mental pain and sense of ill-being, as its leading and dominant symptom. There may in addition be loss of self-control, insane delusions, which are usually suggested by the depression or impulses towards suicide, as well as incapacity to follow ordinary avocations in melancholia. These distinguish it from sane melancholy. Suicide is the great risk in such cases; four-fifths of melancholics being suicidal. The chief of the bodily symptoms are apt to be thinness, weakness, a low nervous and nutritive tone, and stomach, bowel, and liver derangements. Melancholia forms about 30 per cent. of the insanity sent to asylums; but if the cases not sent to such institutions, but treated at home, are taken into account, it forms probably half the total number. It is by far the most conscious and the most manageable form of recent insanity on the whole, being the form next to sanity. Most other kinds of mental disease begin by some amount of mental depression. Of melancholic patients sent to asylums 54 per cent. recover; but a larger percentage than this recovers if the cases treated at home are also included, because, of course, it is the worst class that require asylum treatment. The recoveries from melancholia are the most complete of all forms of insanity. It would seem to be caused by a more entirely functional and dynamical brain disturbance than any other form of insanity that may leave no trace whatever behind it after recovery.

Mania, comprising all *states of mental exaltation*.—The chief emotional forms of such mental exaltation are joyousness and rage, and are commonly accompanied by muscular excitement, restlessness, sleeplessness; the speech tends to become incoherent, the conduct violent or uncontrolled; there are commonly delusions of many kinds. The symptoms range from a joyous elevation with talkativeness and merely want of common sense and foolish conduct up to complete incoherence, delirium, and 'raving madness' or 'acute mania.' In such acute cases the temperature of the body is raised as in a fever; often there is such rapid loss of body weight that 28 lb. are lost in a week, and the patients even die of the disease in about 8 per cent. of such acute cases; while on the other hand 60 per cent. recover and 30 per cent. become incurable. The brain is very congested and hyperactive in acute mania, but this does not result from inflammation.

Folie Circulaire, or *states of regular alternation* between melancholia and mania, forms a small but distinct variety of insanity. More or less periodicity and tendency to recurrence and relapse is unfortunately a very common symptom in most attacks of insanity, and the period between each aggravation is often about four weeks; hence the name 'lunacy.' It is hardly necessary to say that the moon has nothing whatever to do with insanity. Nothing is more discouraging to those in charge of cases than this relapsing tendency; but it should not lead to despair of ultimate recovery, unless such relapses become regular and frequent for years. When this is the case the prospects of recovery are bad. Patients suffering from alternating insanity lead

three lives—one when they are in the melancholy stage, another when in the joyous, elevated stage, and another when nearly sane.

Monomania, or delusional insanity, is that form where insane delusions are the chief signs of the mental aberration. A man may have such insane beliefs of all kinds, utterly unfounded in fact and utterly unchangeable by the plainest demonstration of fact that they are false, without any general depression of mind or exaltation. The intellect is chiefly affected rather than the affective nature in such a case. There are almost no cases of a literal monomania or a morbid false belief on one subject alone. The delusions are morbid in a particular direction, the chief forms being *monomania of grandeur or pride, of aversion agencies, and of unfounded suspicions*. Electricity, mesmerism, telephones, gases, noises made by imaginary persecutors are the common subjects of the second form; while utterly perverse interpretations of the conduct of friends or strangers is the common form of the latter. The two together are sometimes classed as *monomania of persecution*. Hallucinations of the senses—i.e. imaginary sights, sounds, smells, and tastes—are very common in this form of insanity. It is not very curable when the delusions get fixed; but in the early stage, and when dependent on derangements of the bodily health, it is often recovered from. This form of insanity, and delusion generally, is of great importance from a legal point of view, but not so much from the medical side.

Dementia, or conditions of general mental enfeeblement, is the state of mind where the memory is impaired, the reasoning weakened, the feeling diminished, the will especially lacking, the attention and curiosity far below normal, these changes having occurred in a person who had at one time been normally constituted. It is in fact silliness, want of mental force, imbecility not congenital but acquired. This does not usually occur as the first symptom of an attack of insanity, but as the sequel to mania—or, more rarely, melancholia—when it is not recovered from; hence it is commonly called *secondary dementia*. It is in fact the inevitable stage in which these diseases end. The demented patients live on for many years sometimes. The most complete form of dementia occurs after mania that has not been recovered from in adolescence. Dementia is in fact a premature mental death with persisting bodily life.

Stupor embraces those cases where there is mental torpor, in which impressions on the senses produce no effect, the patient neither speaking nor taking notice of anything, and having no volition except to resist, but being able to stand, and walk, and eat. Trance and catalepsy are forms of stupor. The bodily functions are all lethargic in stupor, the heart's action low, the body cold, and the muscles flabby. Stupor commonly occurs in young people of both sexes, and is very curable, 50 per cent. recovering. It sometimes attracts popular wonder and attention, which is very bad for the patient. In some cases it results from profound and terrible shocks which paralyse mind and body. In some cases patients remember all that occurred when they appeared to be taking no notice whatever, and in others the time during which the stupor lasted was a blank to them afterwards.

Impulsive Insanity, or states of defective control, is the last or most recently invented division of the mental classification. In some ways it is the most interesting of all, inasmuch as will is the highest and most essential of all the mental faculties, and volitional disturbances have a closer relationship to morals, law, social life, and conduct than any other aspect of insanity. It is often seen that the

children of insane or drunken parents are lacking in the normal power of control and in their perception of the sense of right and wrong, their conduct being apt to be impulsive and not guided by reasonable motives. Evolutionally the highest of all qualities is thus lessened in amount, this tending towards a disruption and destruction of organised society. If lack of control, criminality, and action from impulse became hereditary and general, society would fall to pieces. All forms of insanity are more or less distinguished by lessened control, but there are persons without general depression or excitement, without insane delusions, without enfeeblement of mind, who will suddenly, and not in obedience to any sane motive, smash furniture, tear clothing, steal, set things on fire, obey gross animal impulses, or kill themselves or others, having no power of control to prevent themselves from doing these things. We now know that certain regions of the brain and nervous centres have as their function the control of other portions, quickening the pace of action or stopping it. In the very highest regions of the brain we find the function of mental inhibition. This controls mental action in other portions of the brain convolutions. In this form of insanity it is supposed that the inhibitory controlling portions or 'centres of mental inhibition' have lost their power. It is as if one's power of controlling the act of coughing on very inadequate irritation was lost. Every minutest point of dust entering the larynx would set up coughing, which would go on independently of the will altogether, as an automatic 'reflex' act. In many of the cases of impulsive insanity the mental portions of the brain act automatically without any controlling action by the inhibiting centres. It is a pitiful and most suggestive thing to see a human being who knows right from wrong, and earnestly desires to do the one and avoid the other, compelled by morbid impulses to act wrongly, all the while bewailing the diseased necessity that is thus laid upon him. The physician frequently sees such a case. Especially is this sight pathetic when the morbid impulse is to take away his own life or that of some one dearer to him than life itself. Such impulsive insanity is often set up in hereditarily unstable brains by weak health and by alcohol. They are often curable. The so-called 'moral insanity' is just one variety of this form of mental disease where the moral sense is absent from disease, and the power of doing right non-existent, while the impulses are all towards immorality.

The clinical varieties of insanity are headed by *general paralysis*, a specific disease of those portions of the brain that subserve mind and motion. It is always incurable, getting progressively worse, gradually impairing and at length destroying speech, motion, mind, and, usually in about three years' time, life itself. In this form of insanity patients commonly have extravagant delusions of wealth and power. It is found chiefly in the male sex, in large cities and manufacturing places, and as yet is almost unknown in the Highlands and the country districts of Ireland. It is a disease of modern life, and is proved to be increasing. *Paralytic insanity* is that connected with apoplexies, softenings and tumours of the brain, which cause ordinary paralysis first, and one form of dementia afterwards. *Epileptic insanity* is that accompanying epilepsy in so many cases. It is often attended by great violence and irritability, and by danger to those around the patient. Many murders are committed by insane epileptics. It is now much more manageable than formerly under modern medical treatment, but is apt to recur after apparent recovery. It prevails most variously in different parts of the country. In Scotland only 7 per cent.

of the insanity is epileptic; in some southern and midland counties of England 25 per cent. is of this character. The true cause of this difference is unknown. *Syphilitic insanity* is the result of brain-poisoning by this terrible scourge of humanity. *Alcoholic insanity* is a very frequent form indeed. Alcohol is the exciting cause of from 15 to 20 per cent. of all insanity; but all the mental disease caused by alcohol is not alcoholic insanity. There can be no doubt that some brains are so prone by heredity to be upset in their mental function that it takes little to do it. If it is not a quarrel with a friend, it is a spree on bad liquor. True alcoholic insanity always has motor symptoms, such as tremblings, convulsions, impaired speech, &c., except *dipsomania*, one variety where the insanity consists in the craving for excessive use of liquor, and lack of control over this craving. Alcoholic insanity may be intensely acute or very mild, very short in duration or very long continued, or incurable. That caused by prolonged steady soaking is the worst. *Rheumatic* and *gouty insanities* are very rare.

Phthisical insanity, or that connected with consumption, is a very interesting variety. The patients are suspicious and unsocial, and often have no cough or spit or other outward sign of consumption, which may not be discovered till the chest is examined. In some cases it is curable. The tendency to consumption and to insanity are often found in different members of the same family. There are various forms of insanity connected with derangement of the reproductive functions. *Uterine, amenorrhoeal, ovarian, hysterical, and masturbatorial insanities*; while pregnancy, childbirth, and nursing are the causes of the *insanity of pregnancy, puerperal insanity, and lactational insanity*. These form 40 per cent. of mental disease in the female sex. They are the most curable of all forms, recovering in over 80 per cent. of the cases. *Puerperal insanity* occurs commonly within a fortnight of childbirth, and is the most acute and one of the most dangerous to life of all insanities, while the most curable, and is attended by the highest temperatures, sometimes reaching 105°. The different periods of life have each their own form of insanity. *Pubescent and adolescent insanity* is always hereditary, is commonly acute and maniacal, usually has remissions and exacerbations, and recovers in over 60 per cent. of the cases, those not recovering commonly passing into the most typical form of *secondary dementia*. This form of insanity should be treated chiefly by milk diet and exercise. It is one of numerous diseases to which the period of development is subject. *Chlosteric insanity* occurs at the period of the 'change of life.' It is usually melancholic in character, and recovers in 53 per cent. of the cases, under proper treatment and conditions of life. *Senile insanity* is typically seen in the *senile dementia* of extreme old age, when the memory and all the faculties have faded away. But spurts of mental excitement and mental depression, with sleeplessness and unmanageability at home, often occur before final dotage. These are often recovered from. They are a half-way house to dotage or a quick road to it.

A number of rarer and less important clinical varieties of insanity have been described. *Traumatic insanity*, from injuries to head; *uramic insanity*, from thinness of blood; *diabetic insanity*; *insanity from Bright's disease*; *post-febrile insanity*, following all kinds of fevers, especially scarlatina; *the insanity of lead-poisoning*; and *myocardematous insanity*.

Causes of Insanity. There can be no question whatever that a hereditary tendency is the chief predisposing cause of insanity. All sorts of disturbing influences to the brain bring out this pre-

disposition into actual disease. No doubt 70 per cent. of all cases have an insane or neurotic heredity. Epilepsy, drunkenness, all nervous diseases, consumption, too exciting or depressing or exhausting employments, or unfavourable conditions of life in ancestry may cause insanity in the offspring. Marriage of near relatives causes it if the stock is bad; not if it is good. The physical causes of insanity, affecting the body, such as alcohol in excess, produce insanity in four times the proportion which mental and moral causes, such as affliction, losses, love-affairs, and religious excitement, do. For the production of a case of insanity there may be, and there usually is, more than one cause—e.g. (1) a man has a heredity; (2) he is at a critical time of life, or is run down in general health, or takes alcohol in excess; (3) he has a money loss, or domestic affliction just before his attack. A heredity to insanity does not mean a bad brain or a weak mind before the insanity comes on. Often it is quite the contrary. It is not the fools that go off their heads.

Nature of Insanity.—No one now doubts that it is due to disorder of function of a certain portion of the brain—viz. that part of the cortex which is the vehicle of all mental function. This bodily aspect of it should never be lost sight of by physicians and relations. Essentially it in no way differs from many ordinary diseases: it begins, runs a definite course, and ends like many common ailments. It may be brought on by disorder in many other parts of the body, upsetting the brain; but with a sound brain there must be a sound mind. The exact pathology of many forms of insanity has not yet been ascertained; but in 80 or 90 per cent. of the cases that die some abnormality can be found in the brain.

Treatment of Insanity.—*Asylums for the Insane.*—The general principles of modern treatment may be divided into *bodily and mental or moral*. The bodily treatment may be generally said to be to put all the organs and functions right if wrong; to get up the strength and fat of the body—the writer preaches the 'gospel of fatness' for all his insane and nervous patients; to restore the tone and right working of the nervous system; to restore the sleep; to give medicines that determine more blood to the brain in cases where there is too little, and to give those that diminish the brain's blood-supply in those where there is too much; to use suitable baths that soothe nervous irritation, and mineral waters; to invigorate and soothe by life in the open air; and to let off undue and morbid nervous energy by much exercise, gymnastics, and massage in some cases, and to secure complete brain and body rest for others. The mental treatment consists chiefly in careful observation, companionship, control, distraction of the mind from morbid thought and feeling by suitable occupations and amusements, and guarding against the dangers of suicide, homicide, and self-neglect. The whole nursing of insanity is a most difficult task, for which the best bodily, moral, and mental qualifications are needed. In old times, and even up to a very recent date, cruelty, neglect, stripes, and tortures without number were the ordinary means of 'treatment.' Cullen, and all the great authors of his time, prescribe so many 'lashes' as a doctor now does so many drops of physic. Even the very medical means used were made terrifying on purpose—'surprise baths' in which patients were without warning plunged and kept till they were nearly drowned, and 'chairs' in which they were 'rotated' till they fainted. The early Christian theory of an evil spirit having entered into an insane man, which must be 'got out of him,' was at the bottom of much of this treatment, and accounted for the utter want of sympathy shown towards

this class of sufferers. Pinel in France, and William Tuke, a York Quaker, in 1792 simultaneously began the new era of humanity, skill, and science for the insane. The next great landmark of progress was when mechanical restraint, in the shape of strait-jackets, &c., was disused, and the 'non-restraint system' of treatment was adopted. This was between 1825 and 1840, and was the work of Charlesworth and Gairdner Hill of Lincoln Asylum, and Conolly at Hanwell. The next advance was made by imitation of Belgian experience at Gheel, where the insane are largely boarded in private families. If not applicable to all, or even to many in Britain, it showed that the insane were not so dangerous as they had been considered. The next advance took place in Scotland, from 1857, through employing the insane more, classifying them better in asylums, making asylums more 'homes' with 'open-door' departments in them, almost abolishing the use of high-walled, enclosed 'airing courts' in asylums for the exercise of patients, sending them out into the open grounds and on the farms instead, and setting up fully-equipped 'hospital' wards with trained nursing for the special medical treatment of the sick and of the recent acute cases, while quiet incurable cases are boarded in cottages in the country under regular inspection and supervision. We are now fully in the scientific era when we hope by careful study of the brain and its disorders to understand the real nature of the disease and apply our remedies with the certainty and exactitude of science in each case. To secure such treatment for most of the poor, and also for many of the rich, *asylums for the insane* are needful.

Every country in Europe has now provision more or less adequate for the care and treatment of its insane. In Germany and Austria asylums are commonly of two classes; the one for the cure of the curable, near large cities, where the patients only stay for a limited time; and the other for the incurable, larger in size, less costly, and further in the country. The same idea is carried out in France (farm colonies), in Belgium, Holland, and in Great Britain; it will certainly be extended, for it enables economy of management to come in where cost is of no avail for cure, and it enables the curative idea to be realised, however costly, among the smaller numbers and individualised patients who are curable. In England the two great establishments at Caterham and Leavesden, each with over 2000 inmates, are the best examples of establishments for the incurable. That at Darenth, Dartford, is for congenital imbeciles and idiots. All three were built to supply the wants of London. The largest asylum in England is Colney Hatch, which contains 2250 patients. This is far too many to be in one institution if it is for curable patients. One of the best known for its scientific work and practical success is that at Wakefield, containing 1400 patients. The English 'registered hospitals' for private patients fulfil a most important philanthropic function. One of them, that at Cheadle, near Manchester, under Mr Mould's most able and original management, leads the way by treating half its patients (150 out of 280) in real homes in the country; such homes being ordinary villas, farmhouses, country mansions, and seaside residences leased for the purpose. Scotland is honourably distinguished by its early care for the insane. Either in the end of the 18th century or the beginning of the 19th, every considerable town in the country (Edinburgh, Glasgow, Dundee, Aberdeen, Perth, and Dumfries) had erected a 'royal chartered asylum' for itself, through the benevolent efforts of individual citizens or of corporate bodies. These made provision for all their insane, poor and rich alike, each helping the other.

Commonly each royal asylum has two houses or departments, one for the poorer and the other for the richer patients. The system has worked well, and by means of it far more complete provision has been made for the insane of moderate means than in England. The largest institution in Scotland is the Royal Edinburgh Asylum at Morningside and Craiglockhart, which has large accommodation for private patients, paying either the higher or lower rates, as well as for pauper patients.

The United States of America have spent enormous sums to make the best provision possible for the mentally afflicted. As much as £600 a bed has been there spent on several 'state asylums' in New York, New Jersey, and Massachusetts. In most of the states all citizens, rich and poor alike, have the privilege of using the state asylums. The members of the Society of Friends in the state of Pennsylvania were the first to make philanthropic efforts to provide 'hospital' accommodation for the insane, their efforts following at a very short interval the work of Pinel and Tuke. The institutions in the United States are now growing to be as large in size as those in the United Kingdom. One of the most original asylums in the world, in its plan, is that at Kankakee, Illinois. It has 1600 patients, and consists of about twenty houses laid out on the two sides of a 'street,' forming in fact an insane town, all of whose inhabitants resort four times a day to a central dining-room or restaurant for their meals, and where a central ward for the sick and the administration buildings are also situated. The provision for the insane in the southern states, however, is backward and defective; and on the whole, it is generally admitted, even by Americans who have seen its asylums, that Great Britain has led the way in its provisions for the treatment of the insane, and that it is still unsurpassed in the world.

There are 135 public asylums and 117 private asylums now in the United Kingdom. The principles of construction of such buildings have become much more domestic and hospital-like and less prison-like than formerly. Each one should be a *hospital-home*, and the different wards in it should be arranged to suit different classes of patients in different states of mind. In fact the careful 'adaptation of the house to its inhabitants' in every stage of their disease should be carried out. There should be in each one *hospital* wards for special mental and bodily nursing, *convalescent* wards just like homes, wards where the most acute and violent and dangerous can be safely and properly treated without annoying the quiet and convalescent. Every means for suitable companionship and for varied occupation and amusement should be provided. A good asylum should in fact be a series of special model dwellings suited to men and women who need a somewhat different mode of life from ordinary mankind. Good asylums for the richer classes have seaside and country houses where the patients go for change in small parties.

The Lunacy Laws.—For the protection of the property of the insane, laws had to be made at a very early period. The first statute on the subject for England was passed in the reign of Edward II., and for Scotland in the beginning of the 14th century. Both had the same end in view. Property then meant land, and the primary duties of land were to the king and the country. If the man who held it from the king was unfit from mental incapacity to perform these duties, then the king had to resume possession or appoint another to take his place and do them. But the man's state could not be ascertained without a formal inquiry by a responsible official—the Chancellor and the chief object of the early statutes was to provide for such an inquiry. If the man was found to be

idiotic or furious, he along with his property passed into the care of his nearest male relative, and there was an end of him so far as the law went. In time some little care was bestowed on him as a human being, apart from his being an owner of land. The principle was afterwards adopted that the inquiry was to be held before a jury, the issue being determined by them, and the consequences of the verdict being carried out under the direction of the Chancellor. Between 1300 and 1889 at least forty statutes were passed in England relating to the insane, and something like eight or ten in Scotland. The most important of them all was the great English Lunacy Act of 1845, passed through the exertions of Lord Shaftesbury, the philanthropist. Its objects were entirely in the interests of the insane, and its effects have been most beneficial in England, while throughout the civilised world its influence for good has been felt. Under its provisions asylums have been erected for every county in England. A Board of Commissioners was appointed who inspect and report on every asylum, and see every insane person whether in or out of an institution; and every precaution was taken that the insane should be well treated, ill-treatment of them being severely punishable. At least £10,000,000 of capital has been laid out in building asylums, and over £1,500,000 a year besides is expended for the maintenance of their inmates. A new statute in 1889 made certain changes which experience had suggested. The Scotch statute of 1857 was founded on the English Act of 1845. Under it a Board of Commissioners in Lunacy was appointed for Scotland, and provision made for the insane of the counties that had no existing royal asylums. Ireland has a very good asylum system, with inspectors in lunacy. Scotland has much the advantage of England in the ease and economy with which the property of an insane person can be taken care of temporarily or permanently under the charge of a *Curator Bonis*, strictly responsible to the Court of Session. England holds to the old, cumbersome and expensive, but very efficient system of a formal inquiry (*de lunatico inquirendo*) by a 'Master in Lunacy' in each case. If the patient is found incapable of managing his affairs (*non compos mentis*), the Lord Chancellor appoints a 'committee of the person' to see to his comfort and proper treatment, and a 'committee of the estate' to manage his property. In addition to the statutes that regulate the care of the property and the persons of the insane, there are acts that provide for the protection of the public and the safe custody of insane persons who have committed crimes or are specially dangerous, the Criminal Lunacy Statutes—and there are three great establishments for criminal lunatics, one at Broadmoor for England, one at Dundrum for Ireland, and one in connection with Perth Penitentiary for Scotland. About three-fourths of the obviously insane are now in asylums or under committees or curators, the others being boarded under supervision in families, or placed in workhouses. And yet, with the great facility for treating the insane in asylums, such precautions are taken by the law and by the boards of lunacy against their abuse that no case of illegal detention of a sane person on the ground of insanity in a public or private asylum was proved in the exhaustive inquiry into the subject by the select committee of the House of Commons in 1877.

Cureability of Insanity. Taking all the cases now technically reckoned as insanity and sent to asylums, 40 per cent. recover; but many of these are subject to relapses, from which, however, they often recover again, just as people have relapses in rheumatism and bronchitis. But if the slight

mental disturbances not sent to asylums at all, and the cases sent to asylums in which there is no organic brain disease nor very advanced senility, are alone taken, the rate of recovery is at least 70 per cent.

Mortality.—The rate is from 80 to 100 per 1000 of the insane living, or about five times the death-rate among the general population. Insanity is in fact a disease of the brain, from which people die as from other diseases.

Ages at which Insanity occurs most frequently.—Taking the number of persons living at the different ages, and the proportion of persons of the same ages who become insane during each period, we find that insanity occurs most frequently in men from thirty to thirty-five, and in women from fifty to fifty-five. But perhaps a more instructive mode of looking at the ages most liable to insanity is to point out that there are periods specially liable to it—viz. at the end of adolescence, from eighteen to twenty-four, when the organism is just attaining reproductive, that is, organic, perfection, heredity being then the chief cause; at mid-life, from thirty to fifty-five, the worries and strains of life, and the climacteric in women being then the chief causes; and after seventy, the general failure of old age, and especially the deficiency of blood to the brain then resulting from its diseased arteries being the cause.

Is Insanity increasing?—In England the number of the insane known to exist has risen from 36,762 in 1859 to 84,345 in 1889, or from 18·67 to 29·07 to every 10,000 of the population; and in Scotland from 6413 to 11,954, or from 19·8 to 28·9 per 10,000 of the population in the same time. But this increase does not prove a real increase of lunacy. For if we take the newly-registered cases of the disease each year, and compare their numbers with the population, we find it has only risen from 4·5 to 6 per 10,000 of the population in Great Britain in thirty years. It is clear, therefore, that there is an accumulation of the insane from the following causes:—viz. (1) through their being taken better care of; (2) the abundance of good institutions, where all the insane poor can be gratuitously treated; (3) the operation of the lunacy laws; (4) the increasing sensitiveness of public opinion as to the neglect or ill-treatment of insane people; and (5) the widening area of the mental disturbances that are reckoned technical insanity requiring treatment in asylums, all these tending to increase the numbers of the recognised and registered insane. There is in fact no proof that insanity as a whole is increasing; certain forms are no doubt increasing, and presumably other forms are diminishing in amount.

Medico-legal and Social Relations of Insanity.—Few persons have studied carefully the mental state of our criminal population but have come to the conclusion that crime is most closely related to mental defect in very many cases. Could we abolish the latter the former would shrink to small proportions. This does not assume that many or most criminals are technically insane persons. They are merely blood-relations of the insane. The law has been gradually altering its tests as to the amount of insanity that absolves from punishment for crime. Of old a man accused of crime had to be totally delirious or fatuous to be absolved from punishment. Now the power of controlling his actions is being gradually made the test. The law has thus approached, and at last coincides with, the scientific views of insanity. Society should have the keenest interest in the mental condition of its members. Soundness of mind is the most precious possession of a people, for there are innumerable degrees and kinds of mental and moral defects that fall far short of insanity, yet are intimately related to it, hereditarily and psychologically—defects that

weaken a people's power of work, diminish its moral force, and impair its social stability. It is one of the most deeply saddening and terrible of the facts in human history that of the men of genius who have raised and glorified mankind few have been without mental disease in their families, and many have themselves fallen victims to it. If it is true that as yet the mode of human development has been such that to get one man of genius nature had to sacrifice mentally many of his kindred, the world should pay some of the debt it owes to its poets and thinkers by an ungrudging care of such victims. To produce in the human brain the greatest mental strength without running the risk of liability to mental disease must be one of the essential problems of the future for the educationist, the sociologist, the politician, and the physician. Insanity is commonly the final breakdown which shows that many previous generations had broken the laws of nature in their lives. It is the outcome of a civilisation in which the true principles of evolution for human beings had not been understood and assisted.

The chief modern authorities are: Blandford's *Insanity*; Bucknill and Hack Tuke's *Psychological Medicine*; Conston's *Mental Diseases*; Griesinger's *Mental Pathology*; Bovan Lewis's *Mental Diseases*; Maudsley's *Pathology of Mind*; Sankey's *Mental Disease*; Savage's *Insanity*; Spitzka's *Insanity*; Ball's *Mabules Mentales*; Esquirol's *Mabules Mentales*; Guislani's *Psychopathies*; Lay's *Mabules Mentales*; Morel's *Mabules Mentales*; Von Krafft-Ebing's *Psychiatrie*; Kraepelin's *Psychiatrie*; V. Ziemssen and Schulz's *Psychiatrie*.

Inscriptions is the name given to records, not of the nature of a book, which are engraved or inscribed on stone, metal, clay, and similar materials. Since ancient documents committed to such destructible materials as papyrus, parchment, or paper have largely perished, inscriptions on harder materials are in many cases the sole sources of our knowledge of ancient history and of early languages; and, even when MSS. have been preserved by copyists, inscriptions, which preserve the original forms of the letters, are of supreme palaeographical importance. All the books of the Phœnicians, Sabæans, Etruscans, Babylonians, Assyrians, Numidians, and Iberians have perished, and hence a considerable portion of our knowledge of early oriental history is derived solely from inscriptions. A very large number of inscriptions are mortuary epitaphs. Others, usually the most important, are records of the events in the reigns of kings. Others are dedications of altars, temples, or aqueducts. Many are of a religious character, recording donations to temples or in honour of the gods. Others are commercial contracts, banking records, receipts for taxes scratched on potsherds, scribbings on walls (*graffiti*), imprecations, and inscriptions on seals, gems, or vases. Probably more than 150,000 inscriptions are known, and a vast literature has accumulated around them. They are, however, usually classed, not by their subjects, but according to the language in which they are written, with a subsidiary chronological arrangement. The chief classes are Semitic, Greek, Latin, Runic, Cuneiform, Egyptian, and Indian.

Semitic Inscriptions.—The oldest inscription in the Phœnician alphabet is the dedication of a bronze vessel, found in Cyprus, which belonged to the temple of Baal Lebanon, and is now in the Bibliothèque Nationale at Paris. It was written in the reign of Hiram, King of the Sidonians, and may be assigned to the end of the 11th century B.C. or the beginning of the 10th. Of somewhat later date, about 800 B.C., is the Moabite Stone, which contains a record of the chief events in the reign of Mesha, king of Moab, including his war with

Ahab. It is now in the museum of the Louvre at Paris. In the same collection is a long inscription on the black basalt sarcophagus of Eshmunazar, King of Sidon, assigned to the close of the 5th century B.C. Among other important Phœnician inscriptions are a sacrificial tariff found at Marseilles; an 8th-century inscription from Nora, in Sardinia; the dedication of a bronze altar by Yehaumelek, King of Gebal; and numerous inscriptions of the Phœnician Kings of Cyprus, one of them a bilingual, which gave the key to the Cypriote writing (see PHOENICIA). In the same Phœnician alphabet is the Hebrew record in the tunnel which brought the water under Ophel to the pool of Siloam. It is assigned to the reign either of Hezekiah or Manasseh in the 7th century B.C. We have also a fragment of an inscription from Herod's temple at Jerusalem, and others from tombs near Jerusalem, which are earlier than the siege by Titus, and numerous early inscriptions from Jewish cemeteries in the Crimea, at Aden, Venosa, Arles, Tortosa, and Rome. At Palmyra there are more than a hundred inscriptions dating from the 1st to the 3d century A.D., but mostly written in the reign of Zenobia, and there are others in many of the museums of Europe. A Palmyrene inscription was found in 1878 at South Shields near the Roman wall. See PALMYRA.

At Nablis there is a Samaritan inscription, written in the reign of Justinian, containing a version of the Decalogue. The most interesting Arabic inscription is one in Kufic characters inscribed with gold letters on blue-glazed tiles running round the Qubbet es Sakra, or Dome of the Rock, at Jerusalem, the great mosque erected by the Calif Abdalmalik in the year 72 A.H. The Nabathean, or early Arabic alphabet, is used in numerous inscriptions on the rocks at Sinai, and also in the Hauran, one of which dates from the reign of Herod the Great. From the neighbourhood of Aden come a large number of inscriptions in the South Semitic alphabet; and there are two early Ethiopic inscriptions dating from the 4th and 5th centuries A.D. at Axum, in Abyssinia. At Hajjiabad and Nakhsh-i-Rustan, near Persepolis, are a number of inscriptions of the Parthian and Sassanian Kings. In one of them Sapor I. records his victory over the Emperor Valerian and the Roman army. These inscriptions are written in a script derived from the Aramean, and exhibit the oldest form of the Pehlvi alphabet. At Singan-fu, in China, is an inscription written partly in Syriac characters and partly in Chinese, dated in the year 781 A.D., and recording the introduction of Christianity into China by the Nestorian missionaries.

The *Corpus Inscriptionum Semiticarum*, a splendid and exhaustive work begun in 1881 by the French Academy under the editorship of M. Renan, will, when complete, include all the Semitic inscriptions in photographic fac simile. The most generally useful book dealing with Semitic inscriptions is Schneider's *Die Phœnizische Sprache* (1869), which contains 225 of the most important. Others will be found in Gesenius, *Monumenta Lingua Phœnicia* (1821), and in the *Corpus Inscriptionum Hebraicarum*. See PHOENICIA, MOABITE STONE.

Greek Inscriptions.—The oldest Greek inscriptions hitherto discovered are the mortuary records from the island of Santorin (Thera) in the Aegean, which may belong to the 8th and 9th, or even to the 10th, century B.C. The earliest inscriptions to which a definite date can be assigned are the records on the knee of one of the colossal statues at Abu Simbel, near the second cataract of the Nile, by Greek mercenaries in the service of Psammetichus, King of Egypt. They date from the end of the 7th or the beginning of the 6th century

B.C. These are followed by the records on the bases of the statues which lined the Sacred Way leading to the temple of Apollo, at Branchidae, near Miletus. They are all earlier than the Persian war, and are assigned to the 6th century B.C. Of about the same date is the celebrated Sigeian inscription from the Troad, now in the British Museum. Of the 5th century is the long and important inscription of Lygdamis, found by Sir C. Newton at Halicarnassus, which belongs to the time of Herodotus. After the Persian war Greek inscriptions became more numerous. The most interesting, from an historical point of view, is that inscribed on the trophy erected at Delphi by the Greeks to commemorate the defeat of the Persians at Plataea. It is now in the Hippodrome at Constantinople, where it was placed by Constantine. Another inscription of historical interest is the dedication to the Olympian Zeus of a bronze helmet, which formed part of the spoils taken at the battle of Cume in 474 B.C., when the naval power of the Etruscans was shattered by Hiero I., king of Syracuse. It was found at Olympia by Sir W. Gell, and is now in the British Museum (see ETRURIA). It was the practice of the Greek states to affix copies of treaties to the walls of their temples. Several of these have been preserved. They are mostly between Athens and her allies, and belong to the 5th and following centuries. The earliest which we possess is a treaty between the Eleans and the Heraeans, which is assigned to the middle of the 6th century B.C. It is engraved on a bronze tablet which was hung in the temple of Zeus at Olympia, and is now in the British Museum. To the 5th century belong the interesting records of the battles fought by the Athenians at Drabescus and Potidaea; also a list, now in the Louvre, of the Athenian citizens who fell in Cyprus and Egypt in the year 460 B.C.; several enumerations of the treasures deposited in the Parthenon; and detailed accounts relating to the erection and cost of the Erechtheum at Athens. The foregoing are the most important Greek inscriptions of the early period. Those of later date are extremely numerous. One of the most interesting, written in Greek hexameters, was discovered in 1879 at Brough in Westmorland. It is in memory of a Syrian youth who is believed to have perished during the campaign of Septimius Severus against the Caledonians in the year 209 A.D. It is now in the Fitzwilliam Museum at Cambridge.

It is estimated that 20,000 Greek inscriptions are known to scholars. More than 10,000 have been published by the Berlin Academy in the *Corpus Inscriptionum Graecarum*, of which the first two volumes, edited by Boeckh, appeared in 1828 and 1833; the third, edited by Franz, in 1853; and the fourth, edited by Kirchhoff, in 1856. Kirchhoff, Kohler, and Dittenberger have edited the *Corpus Inscriptionum Atticarum*, of which the first volume appeared in 1873. The chief historical inscriptions have been published in a handy volume by the Clarendon Press at Oxford, edited by E. L. Hicks, under the title *A Manual of Greek Historical Inscriptions* (1882). The dialect inscriptions are given in Cauer's *Dialects*, and fac-similes of the inscriptions most valuable for paleographical purposes by Rohl's *Inscriptiones Graecae Antiquissimae* (Berlin, 1882). For the beginner in Greek epigraphy, Rohl's *Inschriften Inscriptionum Graecarum* (Berlin, 1883), a cheap and useful little book, and Reinach's *Traité d'Épigraphie Grecque* (Paris, 1885) can be recommended; see also E. S. Roberts, *An Introduction to Greek Epigraphy* (Camb. Univ. Press, 1888). See table at ALPHABET, Vol. I, p. 187.

From Cyprus we have a number of Greek inscriptions in a very ancient pre-alphabetic character, which is usually designated as the Cypriote syllabary, and is believed to be related to the scripts of Asia Minor and Northern Syria, such as the Carian, the Lycian, and the Hittite, which are

known to us only through inscriptions. The most important of these is a long Lycian inscription assigned to the 5th century B.C., found by Sir C. Fellows at Xanthus, which is now in the British Museum. A number of Carian inscriptions, usually recording the visits of travellers, have been found in Egypt, chiefly at Abydos and Abu-Simbel. The Hittite inscriptions, which are written in a hieroglyphic character not yet deciphered, are engraved in Wright's *Empire of the Hittites* (1884). The Vannic inscriptions from Armenia are written in a form of the cuneiform character. See HITTITES.

Latin Inscriptions.—Between 60,000 and 70,000 Latin inscriptions are known. The oldest probably date only from the 3d century B.C. Of the early inscriptions those from the tombs of the Scipios, now in the Vatican Library, are of extreme interest. These, together with several of the oldest Latin inscriptions, are printed in the second appendix to Roby's *Latin Grammar* (1872), and are engraved in fac-simile in Ritschl's *Præter Latinitatis Monumenta* (1862).

Latin inscriptions are couched in a style of their own, consisting of regular epigraphic formulae, with conventional modes of expressing names, paternity, tribe, country, domicile, illegitimacy, adoption, naturalisation, and with abbreviated designations of status for freemen, freedmen, slaves, children, as well as of dignities and functions of all kinds in all the various grades of official life, military, civil, and sacerdotal. There are also conventional formulae for epitaphs; and others are employed for edicts, dedications to the gods, inscriptions on buildings, temples, aqueducts, and statues, as well as *sarcæ*, execrations, and theatrical *tesaura*. Besides formal inscriptions there are numerous *graffiti* scribbled on walls, such as those found at Pompeii, which have a literature of their own. As a specimen of the way of interpreting an ordinary Latin inscription, we may take the first three lines of No. 4114 in the *Corpus Inscriptionum Latinarum*. It begins thus: 'TIB. CL. CANDIDO, COS. XVIR. S. F. LEG. AUGG. PR. PR. PROVINC. IL. C.' &c. These abbreviations are to be expanded as follows: *Tiberio Claudio Candido Consuli, Quindecimviro sacris faciendis, Legato Augustorum duorum, propretore Provinciae Hispaniae Citerioris, &c.* Mortuary inscriptions, which are extremely numerous, usually begin with some stock formula, such as D. M. S. (*Dis Manibus Sacrum*) or H. S. E. (*Hic sepultus est*), and end with a prayer or pious wish, such as O. S. T. T. L. (*Opto sit tibi terra levis*). The Engubine Tables (q.v.) form the chief monument of the Umbrian dialect. There are about 5000 Etruscan inscriptions, which have an extensive literature of their own. See ETRURIA.

A complete collection of Latin inscriptions has been undertaken by the Berlin Academy, with the title *Corpus Inscriptionum Latinarum*, under the editorship of Mommsen, Hübnér, and others. Begun in 1863, this great work already extends to 15 quarto volumes, without reckoning supplements. The best book for a beginner is W. M. Lindsay's *Handbook of Latin Inscriptions* (1898) or Cagnat's *Cours d'Épigraphie Latine* (Paris, 1889). The most complete collection of the dialect inscriptions of Italy—Etruscan, Umbrian, Oscan, and Menapien—is Fabretti's *Corpus Inscriptionum Italicarum* (2 vols. 1867-77), with several supplements. *Die Umbrischen Sprachdenkmäler*, edited by Aufrecht and Kirchhoff (2 vols. 1849-51), and Mommsen's *Die Unteritalischen Dialecten* (1850) may also be consulted. The inscriptions in the Catacombs will be found in De Rossi's *Inscriptiones Christianae veteris Romae*. See LATIN, GRAFFITI.

Runic Inscriptions have been found in great numbers in Sweden, Norway, Denmark, Yorkshire, Cumberland, Kent, and the Isle of Man. Among the oldest is one assigned to the 1st century A.D. on a rock near Trondhjem in Norway; and the Tune Stone, also in Norway, which is assigned

to the 3d century. One of the most interesting is on a massive golden torque found at Buzen in Wallachia. This is a relic of the invasion of the Danubian provinces by the Goths in the 3d century. At Collingham, in Yorkshire, is a Runic inscription in memory of King Oswin, who was murdered in 650 A.D., and there is another at Bewcastle in memory of King Alfrith, who died in 670. At Barnspike, in Cumberland, there is a rock with a long inscription recording the treacherous slaughter by Robert de Vaux, a Norman knight, of Gillhies Bueth, owner of the lands of Lanercoast. The cross at Ruthwell (q.v.), near Dumfries, contains a portion of Cadmon's poem on the crucifixion.

The best collection of Runic inscriptions is by G. Stephens, *The Old Northern Runic Monuments of Scandinavia and England* (3 vols. 1866-84). A selection of the more important will be found in the *Handbook of the Old Northern Runic Monuments* (1884, by the same editor. See RUNES, OGAMS, SCULPTURED STONES.

American Inscriptions.—In Greenland, on the shores of Ballin Bay and Davis Strait, a few genuine Runic inscriptions have been discovered. They probably date from the 11th and 12th centuries, and were doubtless executed by Icelandic colonists or explorers. Records, variously conjectured to be Runic, Punie, Celtiberic, or Numidian, have also been found in the United States, notably on the Dighton Rock in Massachusetts, in the island of Mombegun off the coast of Maine, in the Grave Creek Mound in Virginia, and elsewhere. They prove, however, on examination, to be either natural markings on the rock, or the half-effaced pictorial records of Red Indian tribes, or even inscriptions by early European colonists. Very different are the numerous inscriptions on the walls of the palaces and temples in the ruined cities of Yucatan, Honduras, Mexico, and Guatemala. They are written in unknown characters, which appear to constitute a system of hieroglyphic or pictorial writing, akin probably to that of the Aztec MSS., which as yet have been only imperfectly deciphered.

The *Cuneiform Inscriptions*, from which the contemporary annals of Babylonia and Assyria have been deciphered in recent years, form by themselves a vast department of study. The oldest may date from about 3000 B.C. One of the most notable is the great historical inscription of Darius Hystaspes, engraved on the perpendicular face of a rock, 400 feet above the plain, at Behistun, in Persia. It contains a thousand lines of writing, in three languages, Persian, Proto-Medic, and Semitic Babylonian. Not only is it of immense historical importance, giving an authentic record of the events of the reign of Darius, but it is of great interest as having furnished the clue by which the cuneiform writing was first deciphered. Among other cuneiform inscriptions may be enumerated the annals of Sargon from Khorsabad; the account of the campaigns of Sennacherib, engraved on a colossal bull at Koumjik; the inscription of Samas-Rimmon, son of Shalmaneser, a contemporary of Ahab and Jehu; his inscription of Shalmaneser II., giving an account of the capture of Damascus; the long historical inscriptions of Tiglath-pileser I., of Sargon I., and of Esarhaddon, and the account of the Egyptian campaign of Assurbanipal, besides the inscription of Khammurabi, king of Babylon, which is older than the Exodus, of Uruk, of Naram Sin, of Nebuchadnezzar, of Nabonidus, his successor, and the extremely interesting inscription on the tomb of Cyrus. See ASSYRIA, BABYLONIA, BEHISTUN, CUNEIFORM.

The chief collection of cuneiform inscriptions is *The Cuneiform Inscriptions of Western Asia* (5 vols. folio, 1861-70), edited by Sir H. Rawlinson and E. Norris. Many of the most interesting of the cuneiform and

Egyptian inscriptions are translated in the more accessible volumes of the *Records of the Past*.

Egyptian Inscriptions.—The oldest Egyptian inscription to which a date can be assigned is one of Sent, a king of the second dynasty, who is believed by Mariette to have lived about 4700 B.C. This venerable record is now among the treasures of the Ashmolean Museum at Oxford. The historical inscriptions of the 18th and 19th dynasties are the most numerous and interesting. The records of the Asiatic campaigns of Thothmes I. and Thothmes III., of Seti I. and Rameses II., are all at Thebes. They are older than the Exodus, and constitute the chief materials from which the history of ancient Egypt has been reconstructed. Two of the faces of the obelisk called Cleopatra's Needle, now on the Thames Embankment, bear the name of Thothmes III., who first erected it; on the other two sides Rameses II. has caused his own name to be inscribed. On the wall of a temple at Karnak we have an account of Shishak's invasion of Judaea in the reign of Rehoboam. One of the latest of the Egyptian inscriptions is the Rosetta Stone, a trilingual record in Greek, hieroglyphic, and hieratic characters, engraved on a block of basalt. Its interest arises from the fact of its having afforded the clue which enabled Young and Champollion to decipher the Egyptian writing. See EGYPT, HIEROGLYPHICS.

Indian Inscriptions are extremely numerous. Many of them are grants to temples, engraved on copper plates. The oldest and most interesting are the edicts of Asoka, the great Buddhist king, who reigned over Northern India soon after the invasion of Alexander. There are seventeen versions of these edicts, two engraved on pillars at Delhi and Allahabad, and the rest on rocks in various parts of Northern India, from Orissa in the east to Gujarat in the west. Of later date are the inscriptions in caves, topes, and temples. There are also old Pali inscriptions in Burma, Java, and Ceylon.

The best collections of Indian inscriptions are in the *Corpus Inscriptionum Indicarum*, edited by Cunningham (1877); the *Archæological Survey of Western India*, edited by Burgess (1874-78); the *Elements of South Indian Palæography*, by Burnell (1878); and Muller's *Ancient Inscriptions in Ceylon* (1883). The best guide to Indian palæography is Holle's *Tabl. van Oud en Nieuw Indische Alphabeten* (Batavia, 1882).

See ALPHABET, WRITING, PALÆOGRAPHY, NUMISMATICS. Accounts of most of the foregoing inscriptions will be found in *The Alphabet*, by Canon Taylor (1883).

Insectivora (Lat., 'insect-eating'), an order of mammals, the members of which—shrews, moles, hedgehogs, and the like—are mostly terrestrial, usually nocturnal in habit, and small in size. They feed mainly on insects and small animals, and in adaptation to this diet, which often plays a useful part in the economy of nature, the summits of the molar teeth are beset with small conical tubercles. A few, such as the moles, burrow; a few—e.g. Potamogale—are aquatic; while the divergent Galeopithecus, if included in this order, has among its peculiarities that of gliding through the air (see FLYING ANIMALS). The majority, however, have the general habit of shrews. Though often externally resembling various rodents, the Insectivora are entirely distinct in their anatomy. Altogether over two hundred living species are known, and many fossils, especially from Tertiary strata. The Insectivora are themselves lowly mammals, but lead on to Bats.

See HEDGEHOG, MAMMALIA, MOLE, SHREW; Dobson, *Monograph of the Insectivora* (Lond. 1882); Th. Gill, *Synopsis of Insectivorous Mammals; Bull. Geol. and Geog. Survey, U.S.A.* (Washington, 1875).

Insectivorous Plants. There are several hundred species of Dicotyledons which in some

way or other catch insects and use them for food, either digesting their bodies or simply absorbing the products of their decomposition. They are remarkable for the adaptations of structure and function by which the insects or other small animals are secured, and for their obvious approach to the animal mode of nutrition. For it is a familiar fact that all typical plants feed at what may be called a very low chemical level, obtaining the required carbon from the carbonic acid gas of the air, and the equally essential nitrogen from ammonia, nitrates, and the like in rain-water and soil; while animals, on the other hand, do not derive their carbon from simpler substances than starch, sugar, and fat, nor their nitrogen from a lower source than the albumens manufactured by other animals or by plants. The insectivorous forms, however, break down the distinction in so far as they feed like animals on substances at a high chemical level; and the unity becomes more striking as we recognise that many of the insectivorous plants exhibit marked sensitiveness, mobility, and digestive power.

Altogether there are nearly five hundred species of insectivorous plants, referable to about twelve genera, and to half a dozen Dicotyledonous orders. They are represented in every great geographical region, perhaps with the exception of the African wastes and the Argentine pampas. For convenience of treatment we follow Kerner in recognising three sets: (1) those with pits or cavities, into which small animals enter, but from which they are unable to return—e.g. Bladderworts and Pitcher-plants; (2) those in which the insect-catching depends wholly on the viscidness of the leaves—e.g. *Drosophyllum*; (3) those which exhibit distinct movements which help to secure the insects—e.g. Sundew and Fly-trap.

1. *With Pit-like Traps.*—The Common Bladderwort (*Utricularia vulgaris*,

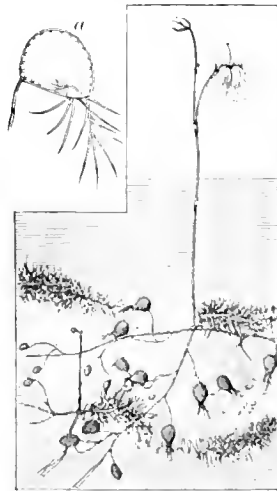

Fig. 1.—*Utricularia Graefiana*:
a, section of bladder of *Utricularia
nepifolia*.

ord. Lentibulariaceae or Utriculariaceae) is a rootless floating water-plant, not uncommon on tarns and marshy lochs, but by no means conspicuous except in summer, when its handsome golden blossoms are raised on a flower-stalk about six inches above the water. Among the slender leaves borne on the straggling floating stem are numerous bladders, to which the plant owes its name. They are much modified dimpled leaf-organs, and form a simple but effective trap. As the figure shows, they are hollow chambers, entered by a door or valve which opens inwards only, and allows of no egress. Tiny crustaceans, known as water-fleas, whether chased by their enemies, attracted by a slight mucilage, or prompted by fatal curiosity, clamber on the antenna-like bristles which project from and perhaps protect the bladders. So far they are safe enough, but if they push their way through the narrow door, they find within the bladder a prison and a tomb. Escape is impossible, death ensues, and the products of decomposition are absorbed by suck-

ing cells (fourfold hairs) on the walls of the bladder. Towards the end of summer, when the water no longer swarms with crustaceans, the *Utricularia* begins to die off, the life is concentrated in terminal buds, the bladders fill with water, and the plant sinks to the bottom. Thence it rises again in spring with a fresh equipment of buoyant bladders. There are numerous species of *Utricularia*, of which several are aquatic like the above; while others, especially in the tropics, are terrestrial. The booty of course changes with the situation, but the general habit seems to be the same throughout. We can only mention an allied genus, *Genlisea*, which has traps of a different pattern, approaching those of the pitcher-plants.

Among the *pitcher-plants*, the most familiar belong to the genus *Nepenthes* (ord. *Nepenthaceae*), which includes nearly forty species, widely distributed by swamps and jungle pools, 'from New Caledonia and New Guinea over tropical Australia to the Seychelles and Madagascar, over the Sunda Islands and Philippines to Ceylon, Bengal, and Cochin-China.' The young plant has a rosette of half-prostrate leaves, quite unlike those of the adult, with a terminal hooked crest overhanging a slightly hollowed broad lower portion. A stem shoots up, however, bearing other leaves, broad and spatulate in form, ending in a cylindrical tendril, which twists round adjacent branches and develops terminally into a large cavity or pitcher. The tendrils gradually lift the stem, and over the pool there eventually hang dozens of pitchers. These vary in size from a couple of inches to about a foot,

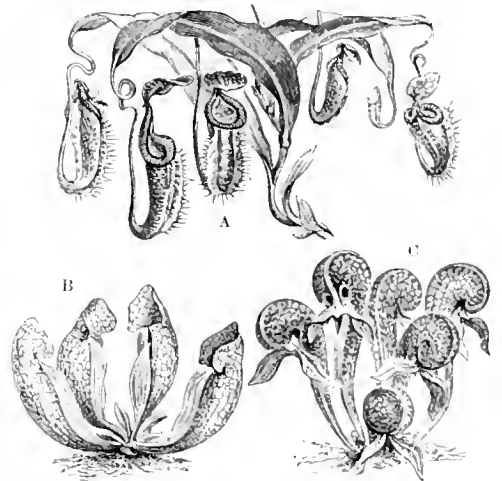

Fig. 2.—Pitcher-plants:

A, *Nepenthes Phyllanthiflora*; B, *Sarracenia purpurea*;
C, *Darlingtonia californica*.

are usually brightly coloured with red, yellow, and purplish blotches, and bear two lateral flanges and a terminal lid, which opens when the pitcher attains its full size. Partly by the colour and partly by the honey glands of the lid and pitcher margin, insects are attracted; they sip the sweet secretion and venture farther down, only to land on an exceedingly smooth, waxed, slippery 'conducting surface,' whence they fall into the lower third or half of the pitcher, which contains water and digestive secretion. When an insect falls, the secretion is stimulated and becomes acid. As analysis has shown the presence not only of various acids (malic, citronic, formic) but also of a peptic ferment, the fluid is exactly like that of an animal stomach, and the result is the same.

Another well-known pitcher-plant is *Sarracenia purpurea* (ord. Sarraceniaceae), widely distributed in swampy regions of eastern North America from Hudson Bay to Florida. A rosette of half-prostrate hollow leaves surrounds an erect flower-stalk. The pitchers are topped by a crest, which is decorated with reddish streaks, and disposed so that it catches rain-drops and lets them slide into the pitcher. Insects are attracted by the sweet secretion of glandular hairs on the lid or crest, wander farther down on a so-called 'conducting surface,' covered with downward-pointed hairs which forbid return, and eventually fall hopelessly into the water occupying the lower part of the pitcher. There they are decomposed and absorbed. Several inches of half-rotten insects are found at the base, rendering the water brown and putrid, and emitting a disagreeable smell. That digestion does not occur seems certain, and the fact is confirmed by Riley's observation that two insects—a fly (*Sarcophaga sarraceniae*) and one of the Lepidoptera (*Xanthoptera scariovoca*)—brave the horrors of the trap in safety, and utilise the dungheap of rotten insects as a suitable place wherein to deposit eggs. The grubs, which would perish if digestion occurred, thrive well and eventually bore their way through the sides of the leaf. Birds occasionally discover the store of insects and rifle the pitchers with their beaks. While all the species of *Sarracenia* probably agree in being non-digestive, they present considerable differences of structure, which we cannot here describe. Beside the above species—*S. purpurea*—may be ranked *Heliamphora nutans* (from Mount Roraima in British Guiana). In *S. carolinensis* and in *Darlingtonia californica* (from the Sierra Nevada) the pitcher is capped by a helmet, so that no water can enter; the contained liquid must therefore be wholly a secretion, though still only putrefactive. Finally, *S. drummondii* and *S. undulata* are in external form almost nearer to *Nepenthes* and *Cephalotus* than to the other species of *Sarracenia*.

In the two species of *Sarracenia* last mentioned only some of the leaves are modified into pitchers, the others remaining green, lance-shaped, and unhollowed. So is it with *Cephalotus follicularis* (Cephalotaceae, near ord. Ribesiaceae), which is restricted to a limited area near Albany in Western Australia. Here in the usual basal rosette only the lower leaves are pitchers, two inches or so in height, best adapted for catching ants and ground-loving insects. The outer surface bears ridges which help the insects up, and there are the usual attractions of bright colour and sweet secretion. Intoxicated, it may be, with the honey, or merely inquisitive and unwary, the visitors pass from the sides or from the half-open lid to the slippery though corrugated



Fig. 3.—Pitcher of *Cephalotus follicularis*.

margin, and thence fall into the liquid which fills half the pitcher. Endeavours to return are balked by a projecting shelf, by an area beset with stiff downward-pointed papillae, and by sharp spines round about the intumed margin of the collar. As the glandular secretion has an acid reaction and a solvent power, *Cephalotus* is also to be credited with true digestion.

In regard to the morphology of the pitchers, we shall simply cite the recent conclusions of Macfarlane: (1) The leaf in *Nepenthes*, *Heliamphora*, *Sarracenia*, and *Darlingtonia* is compound, and consists of from two to five pairs of leaflets; (2) there is a marked tendency to dorsal fusion of the leaflets from apex to base; (3) such fused leaflets

are seen in the broad basal part of *Nepenthes* leaf, and in the flaps and lids of the various pitchers; (4) the pitcher itself is a deep dorsal involution of the midrib just above the termination of the fused upper pair of leaflets, except in *Cephalotus*, where, as Dickson clearly showed, it is an involution of the leaf-blade.

Very different from the pitcher-plants, and with appliances less involved for insect-catching, is the Toothwort (*Lathraea squamaria*, ord. Scrophulariaceae), a pale, chlorophyll-less parasite found in British woods, battening on the roots of trees and shrubs. Excepting the flower-stalk, the stem is virtually underground; it bears stertorial roots and tooth-like leaves. The latter are hollow, and are entered through a narrow aperture by many kinds of small animals. These seem to be entangled in proteoplasmic exudations within the leaf-cavity, find exit impossible, die, decompose, and are absorbed. Along with the toothwort ought also to be ranked *Bartsia alpina*, whose underground buds show a somewhat similar structure and carnivorous habit.

2. *Plants which catch Insects by Viscid Secretion without Pits or Movement.*—The best representative of this set is *Drosophyllum unguiculatum* (ord. Droseraceae), a native of Portugal and Morocco, growing with luxuriance in sandy or rocky places, to a height of about a span. The long linear leaves are richly beset with glands, many borne on long stalks, red in colour, and copious in an acid, viscid, dewdrop-like secretion, the others invisible to the naked eye, without stalks, colourless, and with an acid, dissolvent secretion, which is only exuded in response to the stimulus of some nitrogenous substance. Insects of various kinds alight on the long leaves, knock off the drops from the stalked glands, move anxiously about knocking off more and more until they are thoroughly besmeared, and their tracheae choked. Giving up the struggle, they sink on to the surface of the leaf, where the sessile glands begin the dissolvent and absorbent process. Kerner notes that the peasants about Oporto use the *Drosophyllum* in their dwellings as a convenient substitute for fly-paper.

3. *Plants which exhibit Distinct Movements in their Insect-catching.*—The Common Butterwort (*Pinguicula vulgaris*), belonging to the same order as *Utricularia*, is a widely distributed representative of a genus including about forty species, all growing on more or less marshy ground (see fig. at BUTTERWORT). From a rosette of plump glistening leaves there rises for several inches an upright stalk, bearing a beautiful two-lipped, spurred flower of a violet colour. The leaves have a distinct fungus-like odour, doubtless attractive, and are covered with glands, some stalked like miniature mushrooms, others almost sessile, both with a copious, viscid, acid secretion. This serves as 'insect-lime,' but, besides retaining the unwary midges, it finally digests them. Drops of rain may fall on the leaves, or pebbles may land there, but without noteworthy effect; a small insect, however, stimulates a copious flow of the fatal secretion. But there is also movement: for, when an insect is caught, the margins of the leaves slowly curl inwards for an hour or two, thus surrounding the booty, or shifting it nearer the centre, in any case exposing it to more glands. After digestion, the results and the surplus exudation are absorbed, leaving finally the undigested skin of the insect on the more or less dry leaf surface. More than 150 years ago Linnæus noted how the Lapps used the butterwort for curdling milk, a property due to a rennet-like ferment which the plant has in addition to the digestive or peptic. The antiseptic qualities of the ferments perhaps

justify another old custom of applying the leaves to the sores of cattle.

Beside the butterwort on the marshy moor we are likely to find *Deosera rotundifolia* (ord. Droseraceae) or some other species of sundew. Again, we have a rosette of prostrate leaves, from amid which rises a stalk with inconspicuous whitish flowers. Very striking, and constant in the forty or so species, are the red glandular 'hairs,' 'tentacles,' or processes which grow at different lengths from the upper surface and margins of the leaf. These are complex little structures with a head of glandular cells, supplied by numerous water-pipes (wood-cells or tracheides), and surrounded externally by a drop of viscid secretion. These tentacles are sensitive, mobile, secretory, digestive, and absorptive. To drops of rain they are indifferent, to irritant particles they may respond by increased secretion; but when a midge or a small particle of nitrogenous food is placed upon them, they become marvellously though by no means rapidly active. A living midge, which mistakes the secretion drops for nectar, lights on the leaf, and is forthwith entangled; as it struggles it becomes more hopelessly besmeared, and meanwhile the secretion becomes

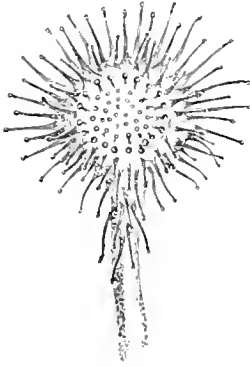

Fig. 4.—Leaf of *Deosera rotundifolia* seen from above.

truly digestive or peptic. More than that, however, the 'tentacles' curve down upon the victim, first one, and then, after an interval of ten minutes, another, till all the two hundred or perhaps half of them close upon the dying midge. The whole leaf may become concave if the booty is large, and then, after an hour or two of leisurely bending, the leaf looks like a closed fist. Many kinds of insects are thus caught, and even a dragon-fly may fall victim to the combined efforts of several adjacent leaves. The sensitiveness is finer than our most delicate nerves or balances, for a sundew hair will respond to a millionth of a grain of stimulating nitrogenous matter. The response is marked by the increased secretion and by the bending, while internal changes are traceable under the microscope passing from one cell to another down the tentacle. As one leaf may be seen with the remains of a dozen insects, and as there are half a dozen or so well-formed leaves, the carnivorous diet of the sundew is often considerable, and it has been demonstrated that the yield of seeds is better in those which are able to gratify their natural appetite.

Venus's Fly trap (*Dionaea muscipula*), which Linnaeus called the miracle of nature, is in several ways a more elaborate insectivorous plant than any of the above, and is the climax of the order Droseraceae. A native of the east of North America, with very local distribution, from Long Island to Florida, it grows on moorland, with a circle of more or less prostrate leaves round the base of a many-flowered stalk, which rises 4-6 inches from the ground. The leaves, about 4 inches in length, consist of a spatulate stalk, which is constricted to the midrib at its junction with the broad blade. The halves of the blade are movable on one another along the midrib, and close together as this volume would do if fitted with an automatic closing spring. Round each margin are twelve to twenty long teeth, which interlock in rat-trap fashion with those

of the opposite side; the centre of the leaf bears numerous rosy digestive glands; and there are on each half of the blade three sensitive hairs, which rise obliquely, but bend flat on a basal joint when the leaf closes. The blade shuts up in 8 to 10 seconds

when one of the sensitive hairs is stimulated, and if an insect is caught in the trap a profuse secretion is exuded from the glands. Digestion goes on for a week or a fortnight according to the size of the booty; finally the digested material and the secretion are absorbed, and the leaf then reopens. There is evidently division



Fig. 5.—*Dionaea muscipula*: a, leaf.

of labour to a greater extent than in the sundew, for the marginal teeth, the sensitive hairs, and digestive glands have separate functions. The delicacy of sensitiveness, the rapidity of movement, and the copiousness of the digestive secretion are noteworthy, while it is also significant that Barton Sanderson has detected electric currents similar to those observed in the neuro-muscular activity of animals.

Superficially somewhat like the bladderwort, in its leaf-structure very like *Dionaea*, is an aquatic plant, *Aldrovanda vesiculosa* (ord. Droseraceae), at home in south and central Europe, flourishing in ponds and pools where clear water is warmed by the summer sun. A thin rootless floating stem bears whorls of peculiarly modified leaves, dies away at one end as it grows on the other, forms in autumn a concentrated terminal tuft, which sinks to the mud at bottom and hibernates. Thence it rises again in spring lightened of its stores of starch and with buoyant air-spaces. The leaves consist of a spatulate stalk and a broad blade, which folds along the midrib like that of the fly-trap. The margin is firm, with small teeth, which meet those of the opposite side when the leaf is closed; externally a few long bristles project; the surface bears numerous longish hairs and also small stellate structures; there are large and small glands. When the water-fleas, insect-larvæ, or even diatoms rest on the surface of the leaf, the half-blades close quickly as in the fly-trap, the victims are imprisoned, and, though they may remain alive for some days, there seems no doubt of their final absorption. Other species of *Aldrovanda* from Australia and Bengal seem to have the same habit.

Besides the true insect catchers noted above, there are not a few plants, e.g. among the Saxifragæ, Sedums, and Primulas, on the glandular surfaces of which insects are often entangled. These plants suggest how the insectivorous habit might begin, and there are two species in the sundew order, *Roridula dentata* and *Eublis gigantea*, in which the insect catching seems to be more than incipient. Among the possibly insectivorous forms we must also include a Brazilian fern, *Elyophoglossum glutinosum*, and several liverworts, e.g. *Ammonohelea mucosa* and *Phiscotum cochleariforme*. Zopf has recently described an interesting fungus (*Arthro-*

botrys oligospora) which catches small threadworms in great numbers in its nooses, riddles their bodies with a growth of fine threads (hyphae), and absorbs the tissues.

Utility.—The adaptations for catching and utilising insects are so numerous and effective, that we are apt to conclude too readily that the insectivorous habit is not only advantageous but necessary for the health of the plants. There are, however, several facts which suggest caution. Thus it has often been noticed that a leaf of sundew or fly-trap may suffer, and even die, from the effects of too big a meal, a serious enough objection to utility were the casualty not as rare in nature as it is common in experiment. More important is the difficulty raised by cultivators, who point to all sorts of insectivorous plants flourishing perfectly without any insect food. To this it can be retorted that the natural conditions of scanty nitrogenous supply are probably not observed in the greenhouse, but the facts force us to abandon belief in the necessity of the insectivorous habit. We can only maintain that it is normally advantageous, a conclusion confirmed in some cases by the decrease in the quantity and quality of the seeds when no insects are available. From this, however, we need not conclude that the insectivorous function is the complete or even the original function of any of the curious leaf-structures above described.

Physiological Summary.—(1) It is a familiar fact that sundew and butterwort generally grow among bog-moss on the moors, hardly rooted in the soil, and therefore less adapted than ordinary plants to suck up the all-important nitrogenous compounds. The same relative scantiness in nitrogenous supplies is more or less marked in the habitats of other insectivorous plants, and doubtless renders them more dependent on their peculiar animal diet. All are said to be averse to the presence of much lime. (2) The diet is to some extent a matter of chance; both creeping and flying insects, small flies and even large moths, besides spiders, and centipedes are caught by the terrestrial and pendent traps. The aquatic bladderwort's most frequent victims are the small crustaceans known as Cyprids; while the subterranean *Lathraea*'s prisoners vary from the rank of mites down to infusorians. (3) The attractions of insectivorous plants are manifold; a mushroom-like odour in the butterwort lures insects which frequent fungi, and some of the others also appeal to the sense of smell; the 'dew-drops' of *Drosera*, the rosy patch on the fly-trap, the bright colours of many pitchers are obvious enough charms; while the frequent exudation of honey is the most direct lure of all. (4) In *Nepenthes* and *Cephalotus*, *Drosera* and *Drosophyllum*, *Dionea* and *Pinguicula*, the bodies of the insects caught are digested, that is to say, chemically altered into soluble substances, which are absorbed by the cells of the leaf. The process agrees with animal digestion in the net result, and in the presence of a peptonising ferment and an acid. Too little is known about the ferment or ferments, and also about the various acids present; but there is no doubt in regard to their digestive activity. It is very important, however, to recognise, with Morren and others, that in plants digestion and the activity of ferments are by no means confined to the insectivorous forms. Thus the diastase which in germinating seeds, &c. turns starchy material into sugar is virtually the same as the ferment in the saliva, &c. of animals; similarly in both plants and animals there is an inverting ferment which turns cane-sugar into grape-sugar; there is also an emulsifying or saponifying ferment in plants, acting on fats and oils in a manner comparable to part of

the role of the pancreatic juice. J. R. Green has described a rennet-forming ferment, comparable to that of the calf's stomach, not only in *Pinguicula*, but in the flowers of *Galium verum*, in the stem of *Clematis vitalba*, in the petals of the artichoke, &c.; finally, a peptonising ferment has been detected not only in insectivorous plants, but in such diverse situations as the latex of *Carica papaya* and the seeds of *Vicia*. The protoplasmic changes of plants are comparable to those of animals not only fundamentally, but also in many details, and the insectivorous plants are not unique, but simply conspicuous illustrations of vegetable digestion. (5) There is no doubt that both the products of digestion and the results of decomposition are absorbed by the insectivorous plants. Large stomata, protruding papillae, suctorial 'hairs,' and other structures in the different plants are sometimes credited with this function, about which little definite information is yet forthcoming. An interesting, if hardly conclusive, corroboration of the absorbent activity is given by Clark, who fed *Drosera* with flies saturated in citrate of lithium, and some days later detected with the spectroscope the presence of the metal throughout the whole plant, in fact even in the flower. (6) The sensitiveness so marked in sundew and fly-trap is not of course unique, but is illustrated in the leaves, tendrils, stamens, stigmas, &c. of many plants, and may be compared—though we cannot go much further—with that of animals. Both *Drosera* and *Dionea* respond to various kinds of stimuli, but usually and most readily to that of nitrogenous substances. Darwin gives numerous illustrations of the sundew's sensitiveness to extremely homeopathic doses (0.000095 of a milligramme) of nitrate of ammonia and the like. In the fly-trap the sensitiveness, as we have seen, is definitely localised in the six jointed hairs. (7) The movements of sundew, fly-trap, and *Aldrovanda*, like those in the leaves of the sensitive plant or the stem of the hop, the stamens of the barberry or the stigma of *Mimulus*, are associated with changes in the cells of the plant. It is easy enough to compare the movements with those of contracting muscles; but we are still far from being able to work out the comparison or determine the divergence. Four points may be noticed: (a) In the tentacles of *Drosera* the movement is associated with a visible change in the contents of the cells. Darwin described this, perhaps mistakenly, as 'aggregation of the protoplasm,' and compared it with analogous changes seen elsewhere. From what we know of movement in other plants, it is likely that the activity of the insect-catchers is connected with a change in the water-tension or turgidity of the cells. (b) In the movement of *Dionea* Darwin detected a measurable contraction or alteration of form; the same has been seen by Cohn, Haeckel, and others in the mobile organs of other plants, and at once suggests the change of form in muscle fibres. (c) Though there is no trace of anything like the nerves of animals, there is no doubt that a stimulus provoking motion passes from cell to cell and from part to part in both sundew and fly-trap. (d) Finally, Burdon Sanderson has described a resting and an action current of electricity in *Dionea*, and concludes that 'the property by virtue of which the excitable structures of the leaf respond to stimulation is of the same nature as that possessed by the similarly endowed structures of animals.'

Although our knowledge of insectivorous plants dates from 1768, when Ellis sent to Linnaeus a description of the fly-trap and its habits, structural investigations prevailed until Darwin in 1860 began the thorough experimental study of insectivorous plants, comparing their sensitiveness,

mobility, and digestive powers with those of animals. Since then the physiological interest of these plants has been kept steadily in view, our analysis of their vital processes becoming with each year more complete. At the same time, the morphology, especially of the pitcher-plants, has been studied with great success. The most difficult question concerning the origin and evolution of the insect-catching structures and functions is still a problem of the future.

See the following general works from which a guide to the vast literature will be obtained: C. Darwin, *Insectivorous Plants* (1875); O. Drude, in Schenk's *Handbuch der Botanik* (vol. i, 1881); P. Geddes, article 'Insectivorous Plants,' *Encyclo. Brit.*; A. Kerner von Marilaun, *Pflanzenleben* (vol. i, 1887); J. Sachs, *Physiology of Plants*, trans. by Marshall Ward (1887); S. H. Vines, *Physiology of Plants* (1886).

Insect-powder is a greenish-yellow powder having a slightly pungent odour. When genuine it is prepared by powdering the closed flowers of various species of Pyrethrum, especially *P. caruncatum*, *P. roseum*, and *P. vincetoxicifolium*. When dusted on fleas and other insects it soon stupefies and finally kills them, but whether this is due to subtle emanations from the oil or to the contact with the powder is undetermined. It is generally stated that the volatile oil does not possess this action, but the writer has noticed that when midges alight on a hand which has previously been rubbed with an alcoholic tincture of the powder they become stupefied, and in many instances rapidly die. The powder is innocuous to man, although it is stated to cause partial confusion of ideas in those who sleep in a room in which much of it has been used.

Insects are numerically the largest class of animals, occupying among Invertebrates a position in many ways similar to that held by birds in the backbone series. Widely separated as birds and insects are in structural rank, they have many common characters: both are very rich in species, and exhibit marvellous variety within narrow range; both are capable of true flight, are on an average very active in habit, and abound in illustrations of gay colouring; both have highly developed sensory and nervous organs.

Like other Arthropoda (q.v.), insects have jointed bodies and limbs, an enveloping cuticle of Chitin (q.v.), a ventral chain of ganglia, and a dorsal brain. Like *Peripatus* (q.v.)—a survivor of the ancestral stock—and like the lower class of Myriopods, insects breathe by air tubes or tracheæ, and are therefore included under the title Tracheata. But, contrasted with *Peripatus* and Myriopods, insects have made two great steps of progress: the body is centralised, with locomotor limbs reduced to three pairs (whence the term Hexapoda), and all the typical average forms have wings. The concentration is seen in the reduced number of rings or body-segments, in the absence of developed appendages on the hind-body (or abdomen) of the adults, in the complexity of the mouth-appendages, and in the gathering together of the ventral nerve-centres. In many cases, however, the progress is emphasised only in the fully-formed insects, for the caterpillar in the absence of wings, with less compact nervous system, with more numerous and primitive appendages, &c., recapitulates an ancestral stage.

To sum up, insects are Arthropods, which are usually winged in adult life, breathe air by means of tracheæ, and have frequently a metamorphosis in their life-history. The adult body is divided into (1) a *head*, with three pairs of appendages (legs), plus a pair of pre-oral outgrowths, the antennæ or feelers; (2) a *thorax*, with three pairs of jointed legs, typically plus two pairs of dorsal,

compressed sacs—the wings; (3) an *abdomen*, without legs, except in so far as these are rudimentarily represented in stings, ovipositors, and the like. It is impossible at present to give any secure estimate of the number of insects, though it is probably safe to say that they exceed all other animals taken

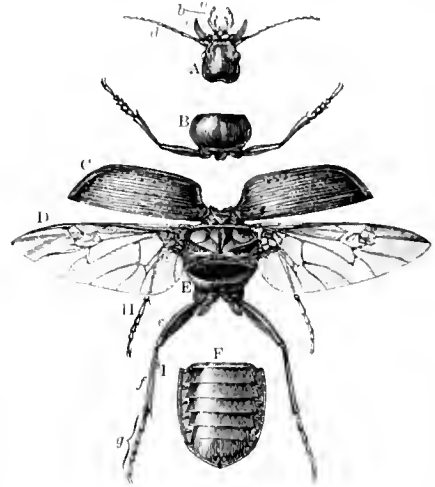

Fig. 1.—Disarticulated Beetle:

A, the head; F, the abdomen; between A and F, the three rings of the thorax; a, maxillary palps; b, labial palps; c, mandibles; d, antennæ; B, prothorax, with first pair of legs; C, wing-covers or elytra; D, functional wings; H and I, two posterior pairs of legs; E, coxa of leg, with projecting trochanter; g, femur; J, tibia; g, tarsal joints.

together. Over 80,000 species of beetles or Coleoptera and about 15,000 moths and butterflies have been recorded; and Speyer estimates the total census at 200,000, while McLachlan concludes that future entomological industry will raise the sum total of insect species to a million.

Structure and Functions.—The anatomy and physiology of insects will be discussed together, and that as tersely as possible, referring to the articles ANT, BEE, BUTTERFLY, &c. for illustrations, and to the works cited for details.

Form.—The body of an insect consists of a distinct, undivided head, probably composed of four obscure segments, of a thorax with three divisions (pro-, meso-, and meta-thorax), and of an abdomen typically with eleven rings. In detail, however, the varieties are legion; thus, the thin waisted wasp contrasts with the cockroach, the lank gnat with the compact bug, the graceful May-flies with the somewhat ungainly locusts, the minute midges with the Goliath beetles, and humming-bird moths.

Appendages.—The jointed feelers or antennæ, which are outgrowths of the head, not strictly comparable to legs, have often numerous nerve endings, and seem to be used in smelling, as organs of touch and guidance, and also in caressing or in communicating impressions to friends. Exactly comparable with legs are the three pairs of mouth-appendages, projecting downwards or forwards from the head, to which they are jointed and from which they are worked by muscles. The first pair—the mandibles—have but one joint, and are without the lateral 'pulp' present in the crustacean organs of the same name. They are biting and chewing organs, and are more or less reduced in those insects which suck. Next come the first pair of maxillæ, which have jointed 'palps.' The second pair of maxillæ are united at their base, and form the so-called labium, also provided with palps. In the different orders, and in association with the

diverse diet, these three pairs of mouth-organs vary greatly, as may be seen by comparing those of cockroach, house-fly, moth, and bee. In connection with the three pairs of legs on the thorax, it is necessary in identifying insects from a manual to become familiar with the division of the limb into coxa, trochanter, femur, tibia, and tarsal joints,



Fig. 2.—Mouth parts of Cockroach (after Savigny):

a, labrum; b, mandibles; c, first pair of maxillæ, with d, stipes; e, lacinia; f, galea; g, maxillary palps; h, sub-mentum of second pair of maxillæ or labium; i, mentum; k, labial palps; l, paraglossa; m, lacinia, the last two together forming the ligula

are seen on that region in the adults. Such hints we find in the lowest wingless insects (Thysanura), and at least plausibly in stings and ovipositors.

Wings.—The adult insect usually bears two pairs of dorsal outgrowths or wings on the two posterior rings of the thorax. These are flattened sacs, really double, worked by muscles, traversed in various patterns by 'veins,' which include air-tubes, nerves, and vessel-like continuations of the body-cavity. They are undeveloped in some passive females, and are likewise absent from many parasitic forms, such as lice and fleas. In these cases the wings have been lost, while they have never been

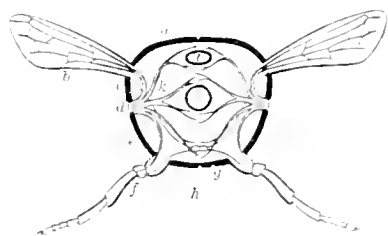

Fig. 3.—Cross-section through the Thorax:

a, tergum; b, wing; c, epimeron or upper part of side; d, stigma or spiracle; e, epidermis or lower part of side; f, leg; g, sternum; h, nerve-cord; i, alimentary canal; l, trachea; l, heart

attained by the lowest insects—the Collembola and Thysanura. When at rest the wings are usually folded in various ways, but the dragon-flies and some others keep them expanded. The two pairs may be almost alike, as in bees and butterflies; those in front may be merely covers (*elytra*) for the hind pair, as in beetles, or contorted rudiments in the little bee-parasites (Strepsiptera); the hind pair may be linked to the fore pair, as in Hymenoptera, and are rudimentary 'balancers' or 'halteres' in flies. They are often hairy or scaly, or gorgeous with pigment, or occasionally odoriferous. Professor Eimer has shown that the colour-

ing and marking of butterfly wings serve as indices of the progress and relationship of species. As to their origin, it seems plausible to compare them to the tracheal outgrowths seen in some aquatic larvae, and to regard them as primarily respiratory and secondarily locomotor. One may venture to suggest that the additional respiratory efficiency derived from such outgrowths would increase the total activity of the insect, and more or less directly lift it into the air.

Locomotion.—Insects are emphatically locomotor animals. They walk, run, and jump with the quadrupeds; they fly with the birds; they glide with the serpents; and they swim with the fish. Even the limbless larvae of many forms move deftly, contracting their bodies, and utilising jaws, hairs, and tubercles to help them along. Some will even

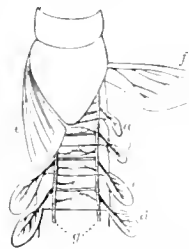

Fig. 4.—Thorax and part of the Abdomen of an Ephemeroid Larva (from Lang, after Graber):

a, rudiments of posterior wing; b, c, d, tracheal gills; e, f, rudiments of anterior wings; g, longitudinal tracheæ; to show close analogy between wings and tracheal gills.

jump to a relatively enormous height of six inches or more, by taking their tails in their mouths and letting go suddenly. The limbed larvae, and especially the true caterpillars, often move with great rapidity; a few jump, and many climb; others utilise their silken threads in spider-like fashion; while the young dragon-flies propel themselves along by the forcible expulsion of water. Even some pupæ move about, but the triumphs of locomotion are seen in the adult insects. Reference must be made to such a work as the *Introduction* of Kirby and Spence, and recourse had to actual observation, if any adequate conception be desired of the variety of ways in which insects walk, run, climb, swim, burrow, and fly. In connection with the flight of insects it may be noticed that the movement of the wings does not essentially differ from that of birds, that motion in a vertical direction is particularly easy, that steering is more difficult, especially since the very lightness of the bodies of insects make them liable to be blown about by the wind. Marey calculates the approximate number of wing-strokes per second at 330 for the fly, 240 for the humble-bee, 190 for the hive-bee, 110 for the wasp, 28 for the dragon-fly, 9 for a butterfly (see FLYING).

Skin.—Insects resemble other Arthropods in having a firm chitinous cuticle formed from the epidermis or hypodermis (see CHITIN, CUTICLE). The cuticle bears scales, tubercles, and hairs, of which the last are sometimes olfactory or otherwise sensory. In spite of the ensheathing armature there are often glands in connection with the skin—witness the salivary glands opening near the mouth in almost all insects, the silk or spinning glands of many larvae, especially of such as make cocoons, the odoriferous glands of bugs and beetles, the poison-glands of the stinging ants, bees, and wasps, the wax-glands of some Aphides, Coccus insects, and bees. Before the full size is reached there are skin castings or moultings, often numerous. The muscular system is almost always highly developed. The muscles which work the legs and mouth-organs, raise and depress the wings, influence the income and expiration of air, control the circulation, and move the segments of the body on one another are most important. The nervous system consists, as in other Arthropods, of a complex dorsal brain or supra-oesophageal ganglionic centre, supplying eyes and feelers, and of a double

ventral chain of nerve-centres. From the first ventral (or sub-oesophageal) ganglia, connected with the brain by a ring round the gullet, the mouth-appendages are innervated. In many insects the ventral chain is centralised in a few ganglia, and is usually more concentrated in the adults than in the larvæ.

Sense-organs.—Except in fleas, lice, and the lowly Collembola, adult insects have compound eyes. These are often associated with simple eyes or ocelli, which are all that ever appear in larvæ or in the three sets of insects mentioned above. Blind insects also occur along with other blind animals in the darkness of caves. Auditory organs are represented in almost all orders by peculiar nerve-endings ('choriotalon' and 'tympalal' organs) superficially disposed on various parts of the body. On the tactile antennæ, and probably also on the maxillary palps of various insects, there are specially innervated skin cells and hairs believed to be olfactory in function; while others more within the mouth are erolited with gustatory sensitiveness. The skin of insects seems in certain regions to be sensitive to the differences of light and shade, so much so that some speak of a sixth or 'dermatoptic' sense. Much experiment and observation is still required on the senses of insects, and we can only mention such general facts as the following. There is sometimes both optic and auditory sensitiveness to impressions which are beyond the range of human sight and hearing; in flower-visiting and other insects there is abundant evidence of sensitiveness to fragrance and colouring, and smell probably aids greatly in that prompt recognition of friends, kindred, or foes which the social insects so well illustrate; there seems little doubt that the power of forming distinct images of external objects, after our fashion of seeing, is very slight in insects. The student should refer to the work of Sir John Lubbock on *The Senses of Animals* (Inter. Science Series, 1888). Similarly, to return to the functions of the nervous system, we can only notice that, in addition to the numerous and often subtle instincts which are ingrained in the constitution of many species, there is indubitable intelligence, as seen in the reasonable adaptation of means to novel ends; that, as in other animals, the intelligence is greatest in the social insects—especially the ants and bees, where it is associated with complex though very small brains. There is also plain evidence of emotion—e.g. in the love-making and parental affection of many insects. See ANT, BEE, BUTTERFLY, INSTINCT, and especially the works of Lubbock and Romanes.

Alimentary System.—The alimentary canal always consists of fore-, mid-, and hind-gut (see GUT), of which the first and the last portions are lined by a thin layer of chitin continuous with the external cuticle. But the length and structure vary not a little in different insects, to some extent in association with the differences of diet. The fore-gut includes mouth, pharynx, and gullet, of which the latter may be swollen into a crop, or bear an appended pouch (so called sucking stomach), or be continued into a gizzard with hard grinding plates. The mid-gut is glandular, digestive, and absorptive; it often bears saecular outgrowths or glandular cæca, and has, as its (endodermic) origin implies, no chitinous lining. In Coleoptera, for instance, its length, which is usually inconsiderable, varies inversely with the nutritive and digestible qualities of the food. The hind-gut is often coiled, terminally expanded in the rectum, and in that region sometimes associated with glands. Its general function is absorption, while from it there spring excretory tubes or Malpighian vessels (see *infra*). As to the food of insects, many are vegetarians, many carnivorous, a few mix both diets;

many feed on the juices of living organisms, others only on putrescence; many actively rifle flowers of their nectar and pollen, or hunt for other insects with great activity,

while not a few are external or internal parasites upon higher animals; the ant-lion digs a pit into which its unwary prey may fall, while dragon-flies attack their winged booty with open violence; among ants some milk the aphides, while others are so degenerate in prosperity that they are actually fed by their slaves. Nor should it be forgotten that some of the higher insects lay up stores of food, usually with parental instinct for the sake of their young, and that the eggs are often laid in the midst of the food suited to the larval

appetite, even in cases where the adults may perish before the young are hatched.

Respiratory System.—Insects when resting often show panting movements in the abdomen, which is swayed by muscles whose activity is the chief condition of the circulation of air throughout the body. For in all insects the whole body is penetrated by air tubes or *tracheæ*, which send fine branches into all the organs and tissues. These tubes are really ingrowths from the skin, and are lined by chitin, raised in what appear to be spiral thickenings which keep them elastically tense.

In most cases these tracheæ open to the exterior by paired apertures or *stigmata* on the breast and abdomen, often guarded by hairs and very variously disposed. There are never more, and usually fewer, than ten pairs of openings, though primitively there was probably a pair to each segment. In aquatic larvæ the tracheæ do not open (if they did the insect would drown), but are spread out on lateral or terminal expansions (tracheal gills), through the thin skin of which the oxygen dissolved in the water is absorbed (see DRAGON-FLY, EPHEMERA, GILL). The very efficient respiration of insects is one of the facts to be kept clearly in view in estimating the general activity of their life.

Here we may notice that many insects produce sounds which often express a variety of emotions. Thus, we have the whirr of rapidly moving wings, as in flies; the buzz of leaf-like appendages near the openings of the tracheæ in many Hymenoptera; the scraping of legs against wing-ribs, as in grass-

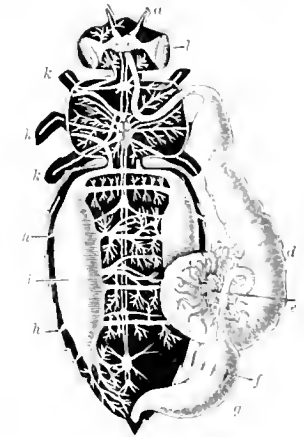

Fig. 5.—Anatomy of Honey bee (after Leuckart) A

a, antennæ; b, eyes; c, honey-crop; d, digestive stomach; e, excretory tubules; f, rectal glands; g, rectum; h, stigmata or spiracles; i, swollen longitudinal tracheæ; k, bases of legs; nervous system in middle line.

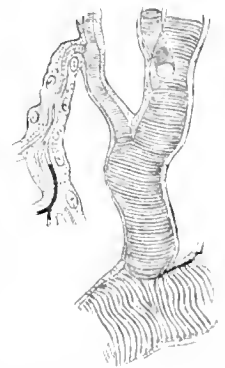

Fig. 6.—Portion of a branching Air tube of a Trachea, showing the internal chitinous ridges.

hoppers; the chirping of male crickets, produced by rubbing one wing against its neighbour; the shrill piping of the male Cicadas, which have a complex drum-like instrument; the voice of the death's-head moth, due to the emission of air from the mouth; and the tapping of the death-watch knocking on external objects. In some cases, where not simply automatic, the sounds serve the alluring purpose of love songs; they may also express fear, anger, and (according to Kirby) even sorrow, or they may give alarm and convey tidings.

Circulatory System. As the tissues are riddled with air-tubes, the need for definite blood-vessels is greatly lessened, and so the circulatory system is slightly developed in comparison with the literally thorough respiratory arrangements. The blood—which is colourless, yellow, greenish, or even reddish, with amoeboid cells—flows for the most part along lacunae without definite walls. There is, however, a central organ, the dorsal blood-vessel or heart.

Within the *body-cavity* of the insect there is often a characteristic mass of tissue known as the 'fat-body.' This is an important accumulation of reserve material, most abundant in the larval stages. In some cases the fat-body of the larva is rich in fat and poor in waste (urate) crystals, while that of the pupa is the reverse, showing that the material is used up in the reconstruction or metamorphosis. In a few insects, such as Fireflies (q.v.) and glow-worms, part of the fat-body seems to become the seat of phosphorescence, the light of which is in many cases a brilliant love-signal. See PHOSPHORESCENCE.

The *excretory system* consists of a set of fine tubes, or it may be threads, which grow out from the upper part of the hind-gut, and wind about often at great length in the body-cavity. The component cells contain abundant waste-products. In different insects the excretory or malpighian tubes vary greatly in number (2-150), and also in the manner of their connection with the gut. The usual type of invertebrate kidney—the nephridium—though persistent in *Peripatus* (q.v.), is not clearly discoverable in insects.

Reproductive System. The sexes are always separate in normal insects; and the Hermaphroditism (q.v.) which casually crops up is in most cases only superficial. In both sexes the reproductive organs are paired, and the products pass out by paired ducts. The latter—the oviducts of the female or the *vasa deferentia* of the male—always open near the end of the abdomen, and, except in the Ephemeroidea, by a single aperture; it is possible that they represent modified 'nephridia.' Accessory external and internal structures in the males may assist in copulation or in making the spermatozoa into packets; of similar structures in the females the most important are the occasional external ovipositors or egg-laying organs, and the internal seminal receptacle in which the spermatozoa received from a male are stored up, and serve to fertilise successive sets of eggs. In the queen bee this store has been known to last for two or three seasons, while Lubbock tells of an aged queen-ant which laid fertile eggs thirteen years after the last union with a male.

Male and female insects are usually somewhat different in external appearance. The males are, on an average, more active, smaller, and more brightly coloured than the females. Extremes are seen in male and female Coccid insects (q.v.); in the sexes of Glow-worm (q.v.); in a few Butterflies (q.v.), such as *Orgyia*, where the female is wingless; or in the curious bee-parasites *Strepsiptera*, where the female virtually remains a grub. As some insects have an elaborate courtship, in which the females choose their mates, and as some males

fight their rivals, there can be little doubt that Sexual Selection (q.v.) has accelerated the evolution at once of beauty and strength, while natural selection (see DARWINIAN THEORY, EVOLUTION) may have retarded the evolution of gay colouring in the females to whom conspicuousness is especially disadvantageous in parentage. Neither position is inconsistent with that which regards the characters of the two sexes as natural and necessary expressions of their respectively dominant constitutions. See Darwin, *Descent of Man*; Wallace, *Darwinism*; Geddes and Thomson, *Evolution of Sex*.

Peculiarities in Reproduction. (a) Virgin birth or parthenogenesis occurs normally, for a variable number of generations, in two butterflies and a beetle, some Coccid insects and Aphides, certain saw-flies and gall-wasps; it occurs casually in the silk-moth and about a dozen other Lepidoptera, partially or voluntarily in the drone-bearing of hive-bees, seasonally in Aphides (q.v.), and in larval life in some midges (e.g. *Chironomus*). (b) Where parthenogenesis occurs for a period and is thereafter followed by ordinary sexual reproduction, as in Aphides, we have to deal with one of the many forms of Alternation of Generations (q.v.). (c) A few insects are exceptional in being viviparous, bringing forth their young alive. This is again illustrated by Aphides, and also by a few flies, by the little bee-parasites *Strepsiptera*, and by some beetles. (d) Many insects are exceedingly prolific—e.g. aphid, silk-moth, and queen-bee. A climax is reached in the queen-termite which for a time goes on laying thousands of eggs (at the rate of about sixty per minute!).

Development of the Egg.—The ovum of insects, as it passes down the ovarian tubes, is enclosed in a firm chitinous envelope, with a minute aperture or micropyle (sometimes with more than one), through which a male element or spermatozoon penetrates before the ovum leaves the mother. The segmentation which follows fertilisation is for the most part peripheral (centrolecithal; see EMBRYOLOGY), while the centre of the egg is occupied by a relatively passive yolk with scattered nuclei. The result of segmentation is a sphere or ellipsoid of cells enclosing the core of yolk, and on the ventral surface of the sphere or ellipsoid the embryo

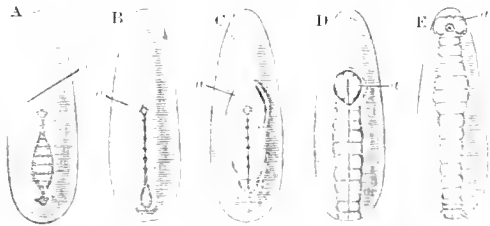

Fig. 7.—Ventral aspect of five stages in the development of the Water-beetle, *Hydrophilus* (after Heider):

The anterior end is uppermost, or head lobes; b, the last of the body-segments, which are seen becoming more marked throughout the series; round about the embryonic area the amniotic folds develop.

begins to be mapped out. This development we cannot here follow, but it is important to notice one unique fact, that the embryo is arched over by a double fold, constituting the internal amniotic and outer serous membranes, so called from their resemblance to the similar enswathing envelopes in the embryos of higher vertebrates. See Langs *Lehrbuch der Vergl. Anatomie* (vol. ii, Jena, 1889), where a summary of results and literature will be found.

Metamorphosis.—(1) In the lowest insects—the old-fashioned, wingless Thysanura and Collembola

—the young form which emerges from the egg-shell is in all respects a miniature adult. Without striking change, by growth and moultings, it becomes an adult. From this entire absence of metamorphosis we readily pass to the life-histories of cockroaches and locusts, of lice and most bugs, where the newly-hatched young are very like the parents. The reproductive organs are, of course, undeveloped, and there are no wings, but the latter are not attained even by the adult lice. All the above forms may be called *ametabolic*—i.e. without marked change or metamorphosis.

(2) In Cicadas there is a slight but most instructive difference between larvæ and adults. The full-grown insects live among herbage, the young live in the ground, and with this diversity of habit is associated at least this much difference in structure, that the anterior legs of the larvæ are adapted for burrowing. Furthermore, the larval life ends in a quiescent stage, or, in other words, the adult form is attained after a period of pupation. But the story becomes more complex when we pass to the Dragon-fly (q.v.), the Ephemera (q.v.), and their relatives, where the metamorphosis is slightly greater, inasmuch as the larvæ are aquatic, with closed respiratory apertures, and with tracheal gills, while the adults are winged and aerial, and breathe by open tracheæ. Such insects are said to have an incomplete metamorphosis, and are called *hemimetabolic*.

(3) Very different, however, is the life-history of all the other insects, such as butterflies and beetles, flies and bees. From the egg-shell there emerges a larva (maggot, grub, or caterpillar), which lives a life of its own, growing and resting and moulting, often very active in its movements and voracious in its diet. Having accumulated a rich store of reserve food in its fat-body, the larva becomes for a longer time more or less quiescent, becomes in fact a pupa, nymph, or chrysalis. In this stage, often within the shelter of a spun cocoon, great transformations occur: wings bud out, appendages of the adult pattern appear, reconstruction and centralisation of organs are effected; and finally, out of the pupal husk there emerges an imago or miniature fully-formed insect. These have a complete metamorphosis, and are called *holometabolic*.

The larvæ of these higher insects with complete metamorphosis differ greatly in different orders. Thus, the 'maggots' of flies (without distinct head, feelers, ocelli, &c.) are distinguished from the 'grubs' of bees (with distinct head), and both from the caterpillars of butterflies, &c., which have limbs as well as head. The limbless maggots and grubs are degenerate, the caterpillar is the more normal type. It is technically called an 'eruciform larva,' in contrast to that of most *Ametabola* and *Hemimetabola*—the 'campodeiform larva,' which is not even worm-like, but like one of the lowly *Thysanuran* insects (Campodea), with the regions of the body well defined, with biting mouth-parts, with locomotor thoracic limbs, &c.

But beyond distinguishing the above two great types of larva (campodeiform and eruciform), and also the maggot, grub, and caterpillar forms of the latter, little more is possible in this general survey, for the larvæ vary enormously, according to their own mode of life—parasitic or roving, aquatic or terrestrial, carnivorous or herbivorous—and according to the peculiarities of the adult forms. We must note, however, the changes in connection with the mouth-organs, especially as these form part of the basis of classification. The mouth-parts may be similar in all stages of life, and then are either adapted for biting (*Monognatha*—i.e. jaws persistent) or for sucking (*Meoarchyncha*—i.e. proboscis persistent); or else they are adapted in the larva for biting, in the adult for sucking, the change

commencing in the pupa, and rarely affecting the larval stage (*Metagnatha*—i.e. jaws changed). See Brauer's classification in Hatcher Jackson's edition of Rolleston's *Forms of Animal Life* (1888).

The Internal Metamorphosis.—One of the most interesting and difficult problems with regard to insects concerns the transition from the larval to the adult structure. In those forms which have no metamorphosis, or only an incomplete one, the organs of the larva develop continuously into those of the adult. It is far otherwise in the complete metamorphosis of the higher insects. There the internal changes are as marked as the external; in fact, there is a gradual reconstruction of organs during the later larval, and especially during the pupal stages. Most of the larval organs are absorbed by amoeboid cells, and their debris utilised in building up new structures. To a certain extent the development of new organs takes place by substitution; that is to say, parts of the larval organs which have not been specialised form the foundations of the adult structures. Of special importance is the appearance in the larva of 'imaginal discs' from which the wings, limbs, and epidermis of the imago or perfect insect arise. It must not, however, be supposed that the transition involves any abrupt change; the absorption, disappearance, and replacement of organs is gradual throughout. Yet almost the entire musculature, a great part of the tracheal system, the larger portion of the mid-gut, and many other parts of the larva disappear and give place to the corresponding organs of the adult which are adapted to a new mode of life. In pursuing this study the reader will best begin with Martin Duncan's *Transformations of Insects*, Lubbock's *Origin and Metamorphoses of Insects* ('Nature' series, Lond.), and then pass to the cited work of Lang and the literature there quoted.

General Life.—Under this title we can do little more than mention some general aspects of the life of insects. (a) While insects are predominantly active animals, we find in contrasting the orders, or better still, the families, abundant illustration of the antithesis (to be read throughout the animal series) between activity and passivity. Thus might the female cochineal insect represent in its torpid, sessile life one extreme, and the exceedingly busy humble-bee another. (b) In the majority of cases the adult insect is short-lived, and dies within the year; an adult Ephemerid may be literally the fly of a day, but from this there are many gradations leading up to the rare cases of a queen-bee five years old, or an aged queen-ant of thirteen. The total length of life, including the metamorphoses, varies not a little with the climate of different countries and the weather of different years, and the life is prolonged in those insects which hibernate, passing the winter in a lethargic state hardly deserving the name of life (see *HIBERNATION, LIFE*; Weismann's essay on 'The Duration of Life' in *Heredity*, 1889; and another essay by Ray Lankester on *Comparative Longevity*, 1870). (c) It is worthy of notice that reproduction in a great number of insects of both sexes is shortly followed by the nemesis of death, love being in such cases at once the climax and end of life. (d) In connection with the influence of climate and seasons the occurrence of different or 'dimorphic' summer and winter broods in some Lepidoptera should be noticed (see Weismann, *Studies on the Theory of Descent*, Meldola's trans. Lond. 1880-82; and Snodder's *Butterflies*, New York, 1881). (e) Nor can we do more than refer to separate articles for description of the fascinating social life of many ants, bees, wasps, and termites. (f) The prolific multiplication of insects is kept within bounds by the limitations of food-supply and weather, by the warfare between insects of different kinds, by the

appetite of higher animals, such as fish, frogs, ant-eaters, insectivores, and, above all, birds. As among other animals, we find among insects abundant illustration of peculiarities which have for their result at least the protection of their possessors. The leaf-insects, walking-sticks, moss-insects, humming-bird moths, scale-insects, &c. are striking examples of a protective mimicry in form and colouring which is illustrated in great variety and frequency throughout the class. Many larvae, as well as adults, show especially in colour a sympathetic relation to their environment, while others, such as Caddis-flies (q.v.), are masked by the external coverings with which they clothe themselves. Many insects are saved by their hard skins, by their disgusting odour or taste, by their deterrent discharges of repulsive fluids, by their assumption of 'terrifying attitudes,' by the simulation of death, or by active resistance with their manifold weapons. See MIMICRY; and Wallace's *Darwinism* (1889) and literature there cited.

Classification.—There is as yet a want of unanimity about the classification of insects. A basis is usually found in the degree of metamorphosis, the characters of the wings, the structure of the mouth-organs, and the nature of the genital and excretory ducts. On many points future embryological research will shed light. All that we shall do here is to give the general grouping adopted by Brauer. See cited text-books of Haldett Jackson and of Laug.

	16	<i>Hymenoptera</i> .—Ants, bees, wasps, gall-flies, saw-flies, &c. (Men. and Met.).
C.	15	<i>Coleoptera</i> .—Beetles (Men., rarely Met.).
METABOLA:	14	<i>Lepidoptera</i> .—Moths and butterflies (Met.).
MEMBRANATA	13	<i>Diptera</i> .—Flies (Met.).
and	12	<i>Siphonaptera</i> or <i>Phlebotomata</i> .—Fleas (Met.).
MEMBRANATA,	11	<i>Trichoptera</i> .—Caddis-flies (Men.).
Metazotha,	10	<i>Psocoptera</i> .—Scurvy-flies (Men.).
	9	<i>Neuroptera</i> .—Ant-lions, lace-winged flies (Men.).
B.	8	<i>Rhinocera</i> or <i>Hemiptera</i> .—Aphides, coccus insects, cicadas, bugs, water-scorpions, lice (the male Coccidae are metabolic).
AMEIABOLA:	7	<i>Thysanoptera</i> .—Thrips (A.).
MEMBRANATA.	6	<i>Coleoptera</i> .—Termites, bird-lice (A.)
	5	<i>Orthoptera</i> .—Cockroaches, locusts, crickets (A.).
A.	4	<i>Phlebotomata</i> .—Pella (H.).
AMEIABOLA	3	<i>Chironomata</i> .—Dragon-flies (H.).
and	2	<i>Ephemeroptera</i> .—May-flies (H.).
HEMIMETABOLA:	1	<i>Dermaptera</i> .—Earwigs (A.).
MEMBRANATA.	0	<i>Culicidaria</i> and <i>Blattaria</i> .—Primitive wing-less insects.

Distribution in Space.—Insects are represented almost everywhere. The majority are indeed terrestrial and aerial, and especially at home in warm and temperate countries, but in the Arctic regions and in hot springs, at great heights above the snow-line and in underground caves, and most surprisingly even in the sea there are insect inhabitants. The *Challenger* explorers found one or more species of the genus *Halobates* (among the Hemiptera) which seemed to be quite pelagic. The limits of distribution are in great part those of climate and of the requisite food, for insects have great possibilities of dispersal, not only in their often extensive flight and liability to be swept along by winds, but through the conveyance of the dormant eggs or even grubs from one shore to another within floating logs. Thus, tropical insects are brought on floating logwood from across the Atlantic, while locusts have been known to fly or to be blown in safety across more than 300 miles of sea. See GEOGRAPHICAL DISTRIBUTION, and works there cited.

History. Insects must have appeared in comparatively early times, for a cockroach-like wing has been found even in Silurian strata. Primitive dragon-flies and also lace-flies (Neuroptera) occur in the Devonian, cockroaches and walking-sticks

(Orthoptera) in the Carboniferous rocks. There seems much reason to believe that the Palaeozoic insects were mostly generalised, 'synthetic' types, prophetic of, rather than referable to, our modern orders. In the Trias Orthoptera abound; the first distinct beetles appear in the Lias, where other higher insects with complete metamorphosis also occur. See especially Scudder in Zittel's *Palaeontologie* (1885).

Pedigree.—As to their genealogy, suffice it to say that the wingless Collembola and Thysanura, at the base of the insect series, doubtless represent primitive forms; these lead us back to some of the less specialised myriopods, and these again to *Peripatus* (q.v.), the sole surviving genus of the ancestral Prototracheata. *Peripatus* links the air-breathing Arthropods to the ringed worms or Annelids, uniting, for instance, in its structure the trachea of an insect and the kidneys or nephridia of a worm. See Lubbock's *Origin, &c., of Insects*, and then the papers of Brauer, Emery, Packard, &c. cited by Haldett Jackson.

Economic Import.—Insects come into contact or collision with human interests in a great variety of ways. As far as they are concerned, the struggle between man and animals is by no means over. Strong in numbers, many of them are directly or indirectly injurious to man and his property to an extent which frequently affects the prosperity of a nation. Direct injuries to man's person are familiarly illustrated in the parasitism of fleas, lice, and other more or less intimate 'boarders,' but these are less important than the share the mosquito seems to have in the loathsome disease *Elephantiasis arabum*. The annoyance of midges is patent, but we feel the delicacy of the threads in life's web when we remember that the house-fly may disseminate the germs of bacterial disease. Personal injuries, however, are dwarfed when we think of those done to property, and especially to crops and herds, by voracious or by parasitic insects. Clothes-moth and furniture-borer, vine-insect and Colorado beetle, the bot-flies which attack sheep, cattle, and horses are familiar illustrations of formidable pests. It should also be noted how the hostile insects which infest forest trees and vegetation generally may occasion changes which have far-off effects on the fauna, scenery, and even climate of a country-side. In connection with injurious insects reference should be made to such articles as APHIS, BOT, CORN INSECTS, HESSIAN FLY, LOCUST, PHYLLOXERA, TSETSE, WEEVIL, &c.; to the well-known and inimitable *Introduction to Entomology*, by Kirby and Spence; to the admirable works of Miss Ormerod; and to the researches of Riley, Packard, and others, in the *Bulletins of the United States Entomological Commission*. From either of the last named sources a guide to the vast literature of this important department of entomology may be obtained.

As to the other side of the account, we cannot ignore our indebtedness to hive-bee and silk moth, to cochineal and lac insects, which furnish us with their unique and valuable products. Others again are indispensable and indefatigable scavengers; many wage effective war upon their injurious kindred; while a few, such as locusts and some



Fig. 8.—*Campoplex staphylinus* (after Lubbock), one of the primitive wingless insects.

larvæ, are even used as food. All these benefits, however, seem small in the light of the great fact that the majority of plants are dependent upon insects, as the unconscious bearers of the pollen essential to the normal cross-fertilisation of flowers.

Plants and Insects.—Referring to the article FLOWER for a statement of the importance of insects in the cross-fertilisation of flowers, we are safe in saying that neither the flowers nor their constant visitors can be understood apart. Many insects, however, injure plants without any compensating benefit, and in this connection must be noted the frequent occurrence of protective structures in plants, which help to dismiss hostile intruders. On the other hand, there are numerous cases in which plants and insects (especially ants) form a mutual partnership. Such 'myrmecophilous' plants are saved by their bodyguard of ants from unwelcome visitors, and the benefit is sometimes returned (to speak metaphorically) by the growth of special shelters or 'domatia,' tenanted by the partner insects. See GALLS, INSECTIVOROUS PLANTS, and the literature cited at FLOWER; also Kerner's *Flowers and their Unbidden Guests* (trans. Lond. 1878); and for references to the works of Delpino, Belt, Huth, &c., on 'myrmecophilous plants,' see Schimper's *Wechselbeziehung zwischen Pflanzen und Ameisen* (1888).

History of the Study of Insects (Entomology).—Insects had their due place in Aristotle's zoological system, and since thoughtful observation began have been studied with much constancy. Malpighi (1628-94), whose name is perpetuated in connection with the excretory tubules, was the first to give a thorough description of an insect's (the silk-moth's) anatomy. His contemporary Swammerdam got further in his investigation of insect metamorphoses. Ray (1628-78) and Linnæus (1707-78) helped to infuse system and order into entomology, while the works of Reaumur (1683-1757) are classical models of carefulness. Rosel von Rosenhof, Bonnet, De Geer, Schaffer, Fabricius, and Lyonnet were among the illustrious entomologists of the 18th century. Cuvier (1769-1832) began the study of insects in early youth with an enthusiasm which he never lost, and was wont to trace to the precision gained in his dissections of insects no small part of his success as an anatomist. Savigny's comparison of the mouth-appendages of insects and other Arthropods was an important step on a path often pursued since; and among the great entomologists of the first half of the 19th century, all more or less influenced by Cuvier's example, were Latreille, Kirby, Dufour, Burmeister, Audouin, Blanchard, Lacordaire, and J. O. Westwood. But beyond this the embarrassment of illustrious names makes compressed history more and more difficult; suffice it to notice the recent progress made in the study of the minute structure—e.g. of the sense organs of insects in experimental analysis of the sensory powers, in elucidating a natural classification, in deciphering the history both of fossil forms and of the individual organism.

Kirby speaks enthusiastically of the wealth contained in a well-stored cabinet of insects, of the problems suggested by the study of their anatomy and physiology, but rightly urges that 'we must behold insects when full of life and activity, engaged in their several employments, practising their various arts, pursuing their amours, and preparing habitations for their progeny; we must notice the hatching and kind of their eggs; their wonderful metamorphosis; their instincts, whether they be solitary or gregarious, and other miracles of their history.' Then we shall echo the words of Pliny, and of all entomologists: 'In these beings so minute, and as it were such nonentities, what

wisdom is displayed, what power, what unfathomable perfection!'

As reference has been made throughout the article to special works, it will be enough here to mention some of the general books—(a) zoological text-books, such as those of Claus, Gogenbaur, Huxley, Lang, and Hatcher Jackson's edition of Rolleston; (b) encyclopædia articles by Newport in Todd's *Cyclopædia of Anatomy and Physiology*, and McLachlan in *Encyclopædia Britannica*; (c) to the more popular natural histories—Cassell's (edited by Martin Duncan) and the Standard or Riverside (edited by J. S. Kingsley); (d) to general works—W. Kirby and W. Spence, *Introduction to Entomology* (4 vols. 1815-26; 1 vol. Lond. 1856); J. O. Westwood, *Classification of Insecta* (2 vols. 1839-40); Packard, *Guide to the Study of Insects* (New York, 1878); V. Graber, *Die Insekten* (2 vols. 1877); L. Camerano, *Anatomia degli Insetti* (1882); W. F. Kirby, *Elementary Text-book of Entomology* (1885); (e) for literature, Hagen's *Bibliotheca Entomologica*, the *Naples Zool. Jahresbericht*, and the *Zoological Record*.

Insectores (Lat., 'perchers'), or PERCHING BIRDS, an order of birds called by Cuvier Passerine or 'sparrow-like.' The order includes more than half the known birds, but can hardly be defined, since the members are marked off rather by a combination of characters than by any uniqueness. The title is usually now replaced by that of Passeres (q.v.).

Insolvency. See BANKRUPTCY.

Insomnia. See SLEEP.

Inspectors. See FACTORY ACTS, MINING, NUISANCES, POOR-LAWS, SCHOOL INSPECTORS, &c. In the military use of the term, there are two inspectors general of cavalry in the United Kingdom and two inspectors of auxiliary cavalry, also an inspector general of fortifications. The former inspect the several corps in their districts, and point out deficiencies, the corps being under the command, however, of its own officers, and not of the inspector-general. The latter is responsible for all fortifications and military works in the United Kingdom. District-inspectors of musketry have been replaced by district-assistant-adjutant-generals, and inspectors-general of hospitals by surgeons-general. Inspectors of infantry, artillery, volunteers, and militia have been abolished.

Inspiration, in Christian theology, is the influence of God on the writers of the Scriptures, which makes these Scriptures the Word of God. The word 'inspiration' is derived from the Vulgate translation (*omnis scriptura divinitus inspirata*) of 2 Tim. iii. 16, which in the revised English translation runs: 'Every Scripture inspired of God is profitable,' &c. The Greek word *theopneustos*, rendered 'inspired,' does not occur in classical Greek, and it might as fairly be rendered 'breathing the divine spirit,' as 'given by the divine spirit.' Belief in inspiration is not confined to Jews and Christians; all religions that are based on a divine revelation by means of sacred scriptures assume and affirm inspiration for that revelation. Orthodox Hindus regard the Vedas as of superhuman origin, and absolutely infallible. The Parsees hold that the Zend-Avesta was revealed to Zarathustra by the personification of the divine will which created the world. And the orthodox Moslem sees in the Koran an earthly copy of the original heavenly text revealed to Mohammed in his trances by the angel of revelation; though various Moslem sectaries, as the Motazilites, treat it with free rationalism.

No doctrine of inspiration is formulated either in the Old Testament or the New. But it may be said that the Jews generally have held a 'high' doctrine of inspiration; and the earliest Christian authors apply to Old and New Testaments the doctrine developed by Philo and the

Alexandrian Jews as to the Old Testament—that the writers were in an ecstatic condition or trance as interpreters of God's will, and as such were unconscious of what they spoke. Origen and later authors denied this *maotic* theory; though Irenæus and Augustine compare the writers of Scripture to the hands which wrote what Christ dictated. There was no definite church doctrine before the Reformation; the Reformers did not discuss fully the nature of inspiration, though the Reformation had emphasised the uniqueness and authority of the Scriptures. It was Calovius (q.v.) who laid down the theory that soon came to be regarded as the orthodox Protestant theory—that nothing exists in the Scriptures which was not divinely suggested and inspired. His followers made the writers dependent on the Spirit for their very words, their choice of expressions and grammatical forms being also divinely perfect. Buxtorf found the Hebrew vowel points inspired, and the Swiss *Fœderata Consensus Helveticæ* (see CONFESSIONS OF FAITH) extended inspiration to the punctuation.

The tendency of all schools of modern Protestant theology has been to pass wholly away from this mode of thought. Without at present regarding those who find in the Jewish and early Christian literature at most inspiring rather than inspired books, we find the extreme antithesis to the Calovian position in the view of those who, accepting divine revelation in the Old and New Testaments, find revelation and inspiration in all that makes the nature and will of God known to us—in the laws of nature as well as in the literature of devotion; and having regard to the fact that the Christian dispensation is a higher form of truth than the Jewish, hold that there is more of divine inspiration in such Christian books as the *Imitatio Christi* and the *Pilgrim's Progress* than in Esther or most part of the Old Testament. Between these extremes are to be found the dogmatic positions of all those who still cling to the Bible as the unique revelation of God in Christ. The differences of spirit are wide, and the divergences in statement innumerable. But they may be referred to a few main types.

Many hold the doctrine of *plenary*, as opposed to partial, inspiration—practically the view called by its enemies rather than by its supporters *verbal* inspiration. Thus Dr Charles Hodge teaches that 'all the books of Scripture are equally inspired. All alike are infallible in what they teach. Inspiration extends to all the contents of all these several books. It is not confined to moral and religious truths, but extends to the statement of facts whether scientific, historical, or geographical.' The object of revelation is to communicate knowledge, whereas that of inspiration is to secure infallibility in teaching. Dr A. A. Hodge holds that some received revelations who were not inspired to communicate them, as Abraham; that sometimes the writer was used by the Holy Spirit as an instrument in making a record of what conveyed to him no intelligible sense (1 Peter, i. 10-12); some, as Balaam, being unregenerate, were inspired though destitute of spiritual illumination. Of those who abide by this view some are more careful than others to protest against a *mechanical* doctrine, holding that they can allow fully for the individuality and special gifts of the various writers of Scripture; all errors are consistently denied, and discrepancies are explained away as trivial and merely apparent (see GOSPELS). The standard is the Scripture in the original tongues, the text being established by criticism. The canonicity of the existing books should on this theory be proved, but is sometimes practically assumed.

In opposition to this view it is sometimes affirmed that inspiration rendered the writers

infallible in teaching religious and moral truth, though they might err as to historical and scientific facts; or that inspiration was but a pre-eminent degree of that spiritual illumination which in a less degree is common to all Christians; or that, while Christ's personal teachings were infallible, the apostles and others were inspired in a less degree. Schleiermacher taught that the authority of the scriptural writers was proportionate to the closeness of their relation to Jesus Christ. Many, protesting against all 'mechanical theories and procrustean formulæ,' hold, with Archdeacon Farrar (in the *Clerical Symposium* cited below): 'The Bible is the book which contains the records of God's dealings with a chosen race, and through them with mankind. Above all, it is the book which contains the gospel of his Son and the lessons of salvation. It is not all of the same value. It is not all written on the same level. It contains some things which were permitted because of the hardness of men's hearts. . . . Much of it is written from the imperfect moral and spiritual standard of times of ignorance, at which God winked. You will find recorded in it without comment or disapproval some opinions and some actions even of good men which were not commendable. You will find attributed to God's command conduct which for us would be heinously criminal. Nevertheless, this book is a sacred book, for the sum total and general drift of its teaching is loftier and diviner than any you will find in the world. Both by its own loftiest utterances and by the Christian conscience which it has trained, and by the final standard of the gospel, it furnishes you with ample means whereby to judge what things are right and wrong. . . . The Bible is no homogeneous whole. It consists of sixty-six different books, the work of at least forty writers, written in different languages and dialects, and separate from each other by hundreds of years. It is not a book, but a library or a literature.' Or, as Horton puts it: 'We call our Bible inspired, because by reading it and studying it we find our way to God, we find his will for us, and find how we can conform ourselves to his will.' It is not more necessary that every word of the Bible should be infallible than that Peter and other apostolic men should never in their teaching have made mistakes, and this we know was not so.

In the Roman Catholic Church some theologians have asserted verbal inspiration; but this has never been the doctrine of the church. Distinguishing between inspiration and the assistance of the Holy Ghost, which would merely, as in the case of general councils, protect from error, the church recognises two factors in an inspired book—the natural powers of the writers on the one hand and the impulse and direction of the Holy Ghost on the other. But the church, which is the guardian of the canon and the interpreter of Scripture, has never defined where the one ceases and the other begins. Catholics have maintained the existence of trilling errors in Scripture; and Cardinal Newman sees no serious difficulty in admitting that there are 'obiter dicta' in Scripture which are not inspired.

See the article BIBLE in this work, as also APOLOGUES, EXEGESIS, ACCOMMODATION, DIVINATION, AUGUSTINE, GOSPEL; the article by Cremer in Herzog, the supplementary article in Schaff's *Religious Encyclopedia*, and that in Addis and Arnold's *Catholic Dictionary*; the relevant parts of the works of Hodge, Oosterzee, Deane, Pfeiderer; Hagenbach's *History of Doctrines*, and works on inspiration by Wordsworth (1861), Gausson (Eng. trans. 1851), Lee (1851), Elliott (1877), Brown (1880), Given (1881), R. F. Horton (1888), Cardinal Newman in the *Nineteenth Century* of February 1884; *Inspiration: a Clerical Symposium*, by the representatives of various

views 1884); A. B. Bruce, *The Kingdom of God* (1889); C. Gore in *Our World* (1890); Sanday's Bampton Lecture on *Inspiration* (1894); and the innumerable works on the subject referred to in the books named.

Instinct, the mental aspect of those actions which take rank between unconscious reflex activities and intelligent conduct. When we observe the lowest forms of life gliding slowly towards their food, or the roots of plants overcoming obstacles in their search for soil and moisture, we recognise activities certainly advantageous, yet so comparatively simple that they almost admit of direct physical and chemical explanation. More complex activity is at once apparent when we watch the fly-trap or sundew catching insects, or notice the protective responses which most animals make to provoking or startling stimuli. These imply an inherited and well-established relation of parts (usually nerve and muscle), such that a frequently recurrent form of stimulus provokes an immediate, definite, and more or less appropriate response. Such actions usually depend on what is figuratively called a neuro-muscular 'mechanism'—i.e. on the power that subordinate nerve-centres have of responding to stimuli without bringing the chief centres (or brain) into exercise. They may therefore occur even in cut-off parts of animals, or after the organism is virtually dead. Higher than these, however, are the marvellous activities, most familiar perhaps in insects and birds, for which more or less of a brain is essential, which are so engrained in the organism that they require no practice, which often adapt means to ends, but show little power of adjustment to novel conditions, which are finally the birthright, not of elect individuals, but of all the members of a species. But as we review the animal series in ascending order we become more and more impressed with yet higher actions, for which a head-centre or brain seems essential, which often require to be learned and are perfected by practice, which adapt means to ends in novel circumstances, and vary greatly among individuals.

So far we have kept apart such words as mind, intelligence, instinct, consciousness; but that is no longer possible or desirable, for the last three grades of activity described above are not only observable facts, but are also parts of our personal experience, and must be considered in that light. Like animals, we of course exhibit immediate neuro-muscular responses to external stimuli: witness the sudden withdrawal of our finger from a burning object unwittingly touched. Such responses, for which brains are not necessary, occur 'without our knowing,' and are called *reflex*. Next on the scale come numerous actions, from the sucking of infancy onwards, which require no practice, deliberation, or effort, but yet have a distinct mental aspect, being usually associated with consciousness, and stimulated rather by perceptions than by sensations. Such actions, learned so long ago that the power of doing them is now entailed by heredity, are more predominant in animals than in ourselves, and are called *instinctive*. Higher than these, and pre-eminent in man, are the actions which deliberately adapt means to ends, with conscious intention and controlling *intelligence*. These lead on to the most characteristically human actions, in which we often seem to hold ourselves as unities apart from what is outside us, and in which we are influenced by general ideas and definite ideals, being in fact self-conscious men. So far there is practical unanimity, but difficulties inevitably arise when we begin to project upon animals our own experience of reflex, instinctive, and intelligent actions. We are forced to argue by analogy, and therefore with uncertainty. It is allowed, however, by almost all that the old-fashioned attempt to call all the higher activities

of animals instinctive, in sharp contrast to the intelligent conduct of man, merely expresses an ignorant prejudice. No competent observer denies that ant and bee, dog and elephant, heaver and monkey, frequently exhibit actions higher than instinctive, in some cases quite parallel to that human conduct which we call intelligent. This, however, does not of course assert that any animals have attained to the human level of self-conscious intelligence, with its ideas and ideals. In thinking about the grades of action, which are usually regarded as stages in evolution, it is well to distinguish the objective or observable characteristics from the subjective or analogical interpretation; and it is also important to recognise that the grades distinguished are not hard and fast, but simply mark areas on an inclined plane which slopes from the amoeba up to man.

Definitions.—We are not concerned here with the general questions suggested by such descriptions of instinct as refer it to 'immediate impressions from the First Mover or from the divine energy acting in the creature,' nor is it necessary to discuss those which make the term include all the adaptive actions of animals in sharp contrast to the intelligence of man. Some others, however, are more to the point. Thus, Hartmann defines instinct as 'action taken in pursuance of an end, without conscious perception of what the end is.' Spencer calls instinct 'a kind of organised memory.' Samuel Butler says 'instinct is inherited memory.' J. J. Murphy describes it as 'the sum of inherited habits.' According to Eimer, 'instinct is inherited capability, and especially inherited habit; or more exactly, instinct is the inherited power of acting habitually and without deliberation in a purposeful, intelligent fashion, under the influence of internal stimuli, plus or minus others from without.' According to Romanes, 'instinct is reflex action into which there is imported the element of consciousness. The term is therefore a generic one, comprising all those faculties of mind which are concerned in conscious and adaptive action, antecedent to individual experience, without necessary knowledge of the relation between means employed and ends attained, but similarly performed under similar and frequently recurring circumstances by all the individuals of the same species.'

Examples.—Instinctive actions are usually perfect from the first and independent of individual experience. Thus, the butterfly makes the remarkable transition from caterpillar to adult habits without hesitation or failure; the bee rifles flowers on its first flight; and the chick in the first few hours of its open-air life makes successful darts at flies. In other cases, however, practice appears to help, as in the nest-building activities of birds. Nor are instincts always sufficiently perfect, for ants store beads instead of grains, and mistake corn-wheat seeds for their own cocoons; flower-visiting insects also patronise bright-coloured wall-paper; and the lemmings in their instinct for going right ahead will swim straight out to sea. Marvellous are the instincts exhibited by social animals such as ants and beavers, by insects which provide elaborately for young which they never survive to behold, and in the nesting and migration of our common birds. Less pleasant, in fact almost devilish in ingenuity, is the instinct of the Spheg wasps, which provide fresh meat for their future larvae by storing spiders, insects, and caterpillars which they have stung in their chief nerve-centres, with the result that the victims are not killed outright, but only paralysed.

Origin of Instincts.—An approximation to the truth will probably be attained by combining the chief theories. (1) Instincts may be the inherited results of compound reflex actions, and are there-

fore in origin unintelligent (Spencer). (2) Natural selection may fix on purposeless habits which chance to be profitable, and convert them into instincts without intelligence being ever concerned in the process (Darwin, Romanes). Weismann points out that not a few instincts are exhibited only once in a lifetime, so that they at least can hardly be the inherited results of practice. He holds that 'all instinct is entirely due to the operation of natural selection, and has its foundation not upon inherited experiences, but upon variations of the germ.' (3) Instincts may arise from habits, which were originally intelligent, becoming by repetition automatic (Darwin, Lewes, Romanes, &c.). Eimer derives instincts from inherited intelligent habits, which are shortened and simplified in evolution, though frequently retaining a trace of deliberation. (4)

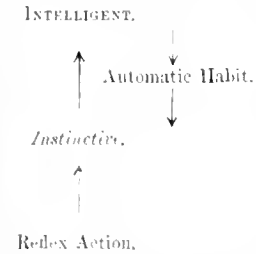

Diagram illustrating origin of Instinct from reflex action on the one hand, from lapsed intelligence on the other (cf. Romanes).

While instincts may arise by natural selection alone, or by lapsing intelligence alone, 'these principles when working in co-operation have greater influence in evolving instincts than either of them can have when working singly' (Romanes). (5) Imitation, as Wallace insists, and the power of rapid learning, which Eimer emphasises, have probably been of importance in the evolution of some instincts. It seems certain that instincts may arise either from unintelligent or from intelligent habits, that their evolution may be abetted by natural selection, and that the power of instinctive action is conserved by the organic memory of inheritance.

See ANT, BEAVER, BEE, BIRD, CUCKOO, ELEPHANT, &c. for illustrations; also BRAIN, EVOLUTION, HEREDITY. For full illustrations, see especially G. J. Romanes, *Animal Intelligence* (Inter. Sc. Series, 1882); Couch's *Illustrations of Instinct*; Lauder Lindsay's *Mind in Animals*; Büchner's *Aus dem Geistesleben der Thiere* (trans.), &c. For theory of instinct, see especially Romanes, *Mental Evolution in Animals*, with a posthumous essay on Instinct by Darwin (1883); compare Darwin's *Origin of Species*; Wallace's *Natural Selection*; Spencer's *Principles of Psychology* and *Principles of Biology*; G. H. Lewes, *Problems of Life and Mind*; S. Butler, *Life and Habit*; J. J. Murphy, *Habit and Intelligence*; Carpenter, Maudsley, Bastian, Wundt, and others on Mental Physiology; E. Von Hartmann, *Das Unbewusste vom Standpunkte der Physiologie* (2d ed. 1877); Schneider, *Der thierische Wille* (1880); Preyer, *Die Seele des Kindes* (1882); Eimer, *Die Entstehung der Arten* (1888); Weismann, *Papers on Heredity* (1889).

Institute. THE, in English law, is the mode of citation or reference to Chief Justice Coke's great work on English law, the name for the first part of which is *Coke upon Littleton* (see COKE). *Institutes* is the name given to the elements of Roman or civil law. See LAW, JUSTINIAN.

Institute of France. See ACADEMY.

Instrumentation is the art of using, in composition, the various instruments and combinations of the Orchestra (q.v.).

Insurance is a contract under which one party, called the Insurer, or Assurer, agrees, in consideration of a sum of money called the Premium, to pay a larger sum of money to another party, called the Insured, or Assured, on the happening of a designated contingency. Insurance has sometimes been said to be akin to gambling, but it is really the converse. The gambler seeks excitement and

gain by the artificial manufacture of hazardous speculations. The prudent man resorts to insurance in order to secure peace of mind and immunity from the loss which might arise from contingencies beyond his control. The gambler creates or exaggerates risks; the insurance office equalises them.

The origin of insurance is lost in antiquity. At a very early period merchants insured their vessels and goods against the perils of the seas, and probably *marine insurance* was the first description to come into existence. From insuring ships and merchandise, the step was not a long one to insure for the voyage the life of the captain, on whom so much depended; and we therefore soon find traces of such contracts, the insurance frequently providing for the sum assured to be paid, not only in the event of the death of the captain, but also in the event of his capture by pirates, or by the king's enemies. Moreover, the merchant in those early days frequently accompanied the vessel in which his goods were shipped. Possibly he had obtained the goods on credit, on condition of paying double their cost should he return safely, and the creditor would thereupon insure the life of the merchant for that particular voyage. *Life assurance* proving in this connection very convenient, it gradually was resorted to in other business transactions, and ultimately came to be sought as a means of family provision.

The first evidence of *fire insurance* is to be found in connection with the Anglo-Saxon guilds, although probably it also was a development of marine insurance. The reader will find full information on the historical aspect of the subject in the various articles in Walford's *Insurance Encyclopaedia*, and in an essay on the 'History of Life Assurance in the United Kingdom,' by the same author, in the *Journal of the Institute of Actuaries* (vols. xxv. and xxvi.).

Life Insurance.—The earliest life-assurance policy of which particulars have been preserved was made on 15th June 1583 at the 'Office of Insurance, within the Royal Exchange,' in London. Full details of this policy have been preserved, because it gave rise to the first authentic disputed claim. The policy was for £383, 6s. 8d., to be paid to Richard Martin in the event of William Gylbons dying within twelve months, and the policy was underwritten by thirteen different persons who guaranteed sums of from £25 to £50 each. The premium was at the rate of 48 per cent. William Gylbons died on 28th May 1584, and the underwriters refused to pay because he had survived twelve months of twenty-eight days each. The Commissioners appointed to determine such cases held that the twelve months mentioned in the policy meant one full year, and they ordered the underwriters to pay. These appealed to the Court of Admiralty, which then had jurisdiction in such cases, and where in 1587 two judges upheld the decision of the Commissioners, so that eventually the underwriters had to pay.

The existing company known since 1698 as the Hand-in-Hand was started in 1696 under the name of the Amicable, and is therefore the oldest insurance company in existence, but it did not begin life business until 1836. The earliest known life-assurance company was established in 1699, and called the 'Society of Assurance for Widows and Orphans.' This was what now would be called an *assessment* company. It did not guarantee a definite sum assured, in consideration of a fixed periodical premium, but by its constitution it was to consist when full of 2000 members who were to contribute 5s. each towards every death that occurred among the members; this contribution being designed to raise £500 on the death of each member, contingent on all members paying up.

The next life-assurance institution started was the famous Amicable (a different company from the Amicable already mentioned). It was founded in 1705, and chartered by Queen Anne on 25th July 1706. Walford, in his *History of Life Assurance*, states that the plan of working was this: The number of members was to be 2000. Amongst the representatives of those who died in the first year one-sixth of the total contributions was to be divided; in the second year, if the full number of members was enrolled, £4000; in the third year, £6000; in the fourth, £8000; in the fifth and subsequent years, £10,000, with a proportionate reduction if the full number of members was not enrolled. The full contribution from the complete roll of members would be £12,000 per annum, and the surplus was to be accumulated. The Amicable lasted as an independent institution until 1806, when it was transferred to the Norwich Union Life Insurance Society, and its policies were finally merged in those of the Norwich Union on 30th June 1886. Various other life offices of the assessment order were started about the same time, but all except the Amicable disappeared on the bursting of the South Sea Bubble in 1720. In 1721 the London Assurance Corporation and the Royal Exchange Assurance Corporation, both of which had been chartered in 1720, received additional powers, under which they were authorised to transact life business. These twins both remain strong corporations at the present day, and are therefore the oldest surviving life offices in the world. The first life policy of the London Assurance Corporation was issued on 7th June 1721. The only other life office which we shall mention here is the Equitable, established in 1762, and prosperous still. Its history for now more than a century and a quarter has been the history of life assurance in England. Its affairs have been conducted by men eminent in the assurance profession, and to its cautiously directed enterprise in early days we are in great part indebted for the scientific soundness of the foundation on which the business of life assurance stands. Since the passing of the Life Assurance Companies Act in 1870 it has been possible to trace minutely the history of every life company. Owing to amalgamations they are diminishing in number. At the time the Act of 1870 was passed there were about £30 in active operation, a number reduced in 1890 to only 88. Under the Act of 1870 a deposit of £20,000 must be made with the Court of Chancery before a company may commence life business, and this discourages the formation of new offices.

The elementary principles of life assurance are very simple. At first the rates of premium were fixed in a purely arbitrary manner, the result of guess work, and no difference appears to have been made in respect of persons of different ages. But as experience was gathered it came to be seen that history repeats itself with great precision; that out of a given number of persons alive it can be approximately foretold from the results of the past how many will die within a given time; and it was further seen that the rate of mortality has a tendency to increase with the age of the lives observed—that is to say, for instance, that out of a thousand persons alive aged thirty fewer will die in a year than out of a thousand persons aged sixty. The first result of this advance in scientific knowledge was that a limit of age was fixed beyond which applicants were not admitted into the assurance offices, the Amicable refusing all aged forty-five and over; a little later on the Equitable was started upon the still more scientific principle of charging rates varying according to age. Early investigators tried to embody the

results of experience in tabular form, and so produced forerunners of what are now known as mortality tables. These show, out of a given number born, how many complete each year of age, and by means of a properly constructed mortality table the rates of premium which should be charged for the assurance of lives can readily be calculated. John de Witt, Grand-pensionary of Holland, was apparently the first to apply scientific principles to the calculations connected with annuities, which are analogous to those connected with assurances, his report on this matter being distributed to the members of the States-general on 30th July 1671. The first mortality table was based upon observations in the city of Breslau, and was prepared by E. Halley, Astronomer royal of England, and published in the *Philosophical Transactions* for January and March 1693. The first tables of premiums used by the Equitable Society were prepared from the mortality of the year 1741 by James Dodson, author of the *Mathematical Repository*, who was associated with Thomas Simpson, the well-known mathematician, in founding the society. Later on the Equitable adopted tables derived from the London bills of mortality, and later on still, that known as the Northampton table, constructed by Dr Price from the statistics of the parish of All Saints, Northampton, during forty-six years from 1735 to 1780. The earliest mortality tables were prepared from a record of the deaths alone; but it was subsequently discovered that this gave erroneous results, and had a tendency very much to exaggerate the estimate of mortality. Joshua Milne, actuary to the Sun Life Assurance Society, seems to have been the first to construct mortality tables correctly by comparing the numbers dying in each year of age in a population with the numbers alive at each age. On this principle he constructed the famous Carlisle table, based upon the population of the parishes of St Mary and St Cuthbert, Carlisle, in 1780 and 1787, and the number of deaths that took place in each interval of ages in the same two parishes during nine years, beginning with 1779 and ending with 1787. The Carlisle table formed for many years the basis on which were calculated the premiums and the reserves of a great many of the leading insurance companies, and so accurate was it that even at the present day its use has not been entirely discontinued. The records of the Equitable Society furnished materials for the construction of mortality tables from the experience of assured lives, and Griffith Davies, F.R.S., actuary to the Guardian Assurance Company, compiled the Equitable assurance table (1825) from data he derived from the annual addresses of the actuary of that office. Later on a committee of actuaries collected the experience of seventeen insurance companies, and the results were published in 1843. Again, the Institute of Actuaries collected the experience of twenty companies and gave it to the world in the volume of *Mortality Experience* in 1869; and these last tables are at the present day considered the best, and with British insurance companies are rapidly superseding every other. Many individual companies have also taken out their mortality experience, and tables have been prepared from the experience of foreign companies by American and continental actuaries.

In the calculations of a life office the probabilities of life are combined with the interest of money. To take the simplest possible example: According to the Institute of Actuaries' mortality table, out of 1000 children aged ten 956 will attain the age of twenty-one. Now, assuming that exactly 4 per cent. compound interest can be realised, the sum required to be invested at once in order to provide

£100 at the end of eleven years is £61, 19s. 2d. If it be arranged that each of the 1000 children aged ten shall receive an endowment of £100 on coming of age, it is clear that 956 such endowments must be arranged for, and the amount now required to provide them is £62,100, 3s. 4d. In respect of each of the 1000 children, therefore, a sum of £62, 2s. must be paid down if he is to receive £100 on reaching his majority. This sum is called the present value of, or the single premium for, the endowment. An annuity consists of a series of endowments, the first payable at the end of one year, the second at the end of two years, and so on; and its present value, or the sum required to purchase it, is found by calculating the value of each of these endowments and adding the whole together. Similarly, if a sum of money is to be paid on the death of an individual, a calculation is made for the premium to cover the risk of death in the first year; so also for the second year, for the third year, &c., to the utmost possible duration of human life; and the results are added together in order to find the single premium for an assurance on his life. For the annual premium an equation is made between the value of an annuity on the life and an assurance on the same life; and thus the annuity—in this case called the annual premium—equivalent to the single premium is ascertained. In order that such calculations may be made easily and simply various monetary tables are in the first place prepared, and the calculations, which would otherwise be so laborious as to be almost prohibitive, are thereby rendered very brief and easy. On principles similar to those adopted in such simple cases as are above indicated, actuaries are able to solve many complicated problems. For instance, it is easy to ascertain what should be the premium for an assurance payable in the event of one person of a given age dying before another person of a different age; or many lives may be introduced with various orders of survivorship. The simpler questions of this nature may be solved directly from the mortality table and the subsidiary tables which are usually prepared from it; but when very complicated questions arise other processes must be resorted to. The late Sir J. W. Lubbock, Bart., in the *Cambridge Philosophical Transactions* for the year 1829, was the first to give a formula of approximation. Mr W. S. B. Woolhouse, in the *Journal of the Institute of Actuaries* (vols. xi. and xv.), produced a formula essentially the same as that of Lubbock, but different from it in that he used the differential calculus instead of the calculus of finite differences. Mr G. F. Hardy, in the *Journal of the Institute of Actuaries* (vol. xxiv.), greatly extended and improved Mr Woolhouse's formula, and threw it into various shapes to suit different circumstances, so that for practical purposes these formulas can now be applied to solve the most complicated questions in a very easy manner. Later on Mr Woolhouse again took the matter up, and, in the *Journal of the Institute of Actuaries* (vol. xxvii.), investigated the general principles upon which these formulas of approximation are based, and deduced several of still greater power than those which had previously been put forward. Little more therefore remains to be done in this direction.

It has already been remarked that the rate of mortality increases with the age. The usual custom of insurance companies is, however, to charge a uniform premium throughout life, and it naturally follows that this premium must be in excess of that required for the mere assurance in the earlier years when the mortality is comparatively light, so that that excess may be accumulated at interest, and become available in the later years of the policy when the rate of mortality is

heavier, and when the uniform premium charged is no longer sufficient for the risk. In this respect life assurance differs from fire insurance. With fire insurance a reserve is required only for the unexpired portion of the time for which the premium has been paid, and to provide against fluctuations and contingencies. In life assurance also, a reserve is required for these objects, but, in addition, a reserve is necessary, as above pointed out, on account of the increasing rate of mortality. Hence it follows that life companies transacting business by uniform premiums must accumulate large funds, which are not profit, but are absolutely necessary in order to meet prospective liabilities. This is clearly shown when a company, as sometimes happens, closes its door to new business, and determines simply to continue its existence in order to run off current contracts. For a time the funds will increase, but presently it will happen that the claims will absorb the whole of the premium and interest income. A little later on the claims will be in excess of such income, and the investments will have to be drawn upon, until when the last policy falls in the funds will be completely exhausted. In the early days of the Equitable Society, when it was uncertain what would really be required to cover the risk, much larger premiums than ultimately proved to be necessary were charged; and, as there were no shareholders, the large surpluses which accumulated were distributed among the policy-holders. This system became so popular that when other companies were started at a later date, although the rates of mortality were much more accurately understood, an additional premium, over and above that required for the risk and for expenses, was deliberately charged, so as to provide a fund out of which bonuses might be paid to the policy-holders. It is now the universal custom of life offices to have a participating class of policy-holders, among whom the periodical surpluses are distributed. There are many ways in which these so-called profits are divided. With some companies the bonuses are large in the early days of a policy, and gradually diminish as time goes on. Others again give comparatively small bonuses at the outset, these increasing with the lapse of time; and others again give practically uniform bonuses throughout the duration of the policy. Some companies make it a feature to return the surplus in cash, or as a reduction of the premium. Others treat the share of surplus belonging to the individual policy-holder as a single premium to provide an assurance on his life, in this connection called a reversionary bonus; so that instead of paying away at once the money to the policy-holders, the sums assured under the policies are increased. Other companies combine these various methods, and give policy-holders their choice. The systems being essentially so different, it is difficult to compare one company with another, and the intending policy-holder should judge for himself which system would best suit his own circumstances, and act accordingly.

The Institute of Actuaries, founded in 1848, was incorporated by royal charter in 1884. Its journal, regularly published now for over forty years, contains a vast number of most important and useful original contributions on the theory and practice of life assurance. All the leading actuaries have contributed, and every discovery of importance in actuarial science has first been published in its pages. By its meetings, at which papers are read and discussed, the institute has also done much to promote the investigation and to disseminate the knowledge of life contingencies. In early days it initiated the system of examinations, and gave certificates of competency to students who satisfactorily passed them, so that the directors of

insurance companies could know who were the men qualified for posts that might become vacant. Later on lectureships were added to train the students, and under the auspices of the institute a text-book in two parts has been published, dealing respectively with interest and annuities certain, and with life contingencies; the former by W. Sutton, M.A., and the latter by the writer of this article. Another great achievement of the Institute of Actuaries was the collection of the materials for the mortality experience of twenty companies, and their compilation in the form of mortality tables and monetary tables. The Faculty of Actuaries of Edinburgh and the Actuarial Society of Edinburgh have also done good public service.

The Life Assurance Companies Acts, 1870-72, were passed owing to the disastrous failure of two great companies, the Albert and the European; and under them companies must register their accounts in specified form, and at periodical intervals give very full details relating to their actuarial valuations. The view taken by the British legislature has been that it is well to allow the companies to be managed by their own responsible officials, and that the government should not actively interfere, but that for the protection of the public full information should be available. The acts also have proved a great benefit by providing for the reconstruction instead of liquidation of insurance companies. A third great advantage of the acts has been that reckless amalgamations have been rendered impossible, while amalgamations that are for the good of all the parties interested have not been interfered with. Now such full details of everything that is done in connection with an amalgamation must be published, that anything like extravagance or unjustifiable expenditure is impossible.

Fire Insurance, Marine Insurance.—The contract of fire insurance is a contract purely of indemnity—i.e. the assured may not make a profit out of a fire, but is merely indemnified against loss sustained. Therefore it is not the cost of the goods at the time of purchase that is taken account of in settlement of a loss, but their value at the time of the fire. For instance, if a merchant have stored cotton for which he gave £1000, and if a fire occur when his stock would realise only £800 if placed upon the market, then £800 is the limit of the amount he can recover, although he may have been holding the cotton for an advance in prices. Again, if a householder have a claim upon a company, he can only recover in respect of the value of his furniture and effects, after allowing for the depreciation due to wear and tear—i.e. by the contract of insurance he is entitled only to be placed in the position which he occupied immediately before the fire, and not in one better. In this important respect fire insurance differs from life assurance, because in the case of a life policy, the amount of the interest of the assured is fixed at the time the policy is issued, and he may on the death of the life assured recover that full amount, although at the time of the death his interest may possibly have altogether ceased. The contract of fire insurance differs also in important respects from the marine insurance contract. In the latter, if goods are assured for less than their value, the policy-holder carries the risk himself for the amount uninsured. For instance, if a merchant have goods on a vessel to the value of £1000, and if he insure for £500, and if damage to the goods occur to the amount of £500, he can recover only £250, he being his own insurer for the difference between the value of the goods and the amount of the policy (for fuller information on Marine Insurance, see AVERAGE). In the case of the fire insurance contract, however, the whole £500 could

in such event be recovered from the company, unless in the exceptional case of an average clause having been inserted in the policy. By the average clause the insured is made his own insurer for whatever amount is not covered by fire policies, and it is sometimes inserted in policies covering large trade risks, and also in those covering goods stored in scattered warehouses. By the usual wording of fire policies, the company has the right to refuse a renewal premium, and here again there is a marked difference from a life policy, which is renewable at the option of the assured, but not of the insurer. A fire policy is not assignable without the consent of the office, which it is usual to give by the way of indorsement. Thus, if a merchant whose goods are covered by insurance sell the goods, the protection of the fire policy is not thereby transferred, but the purchaser must make his own arrangements. Thus, in the common occurrence of the purchase of a house, although the house may have been covered by a policy in the name of the vendor, the purchaser cannot recover under it without an indorsement having been placed upon it transferring the insurance from the vendor to himself. The contract of fire insurance is personal between the insured and the office, and the insured can therefore recover only the amount of his own personal loss. Thus, for instance, unless so stated in the contract, the goods of a servant are not covered by the fire policy in the name of the master; and goods in the hands of an agent are not covered by a policy in the agent's name. As the wording of fire policies is very strictly construed by the courts of law, and as the offices for their own protection are often compelled to take their stand on the literal contract, though they seek to meet liberally every *bona-fide* claim, the policy-holder should be careful to see that his policy is in accordance with his wishes.

Prior to 1869 a special tax was imposed on fire insurance companies, and the returns they were called upon to make furnished an accurate record of the amount of fire insurance business transacted in the country. In 1869, however, the tax was repealed, and a stamp of one penny only on each policy was substituted. The result is that, except in the metropolis, where for the metropolitan fire-brigade, under act of parliament, a rate is paid by the companies in proportion to the amounts assured, it is impossible to say what is the total business of the country. Many of the companies voluntarily publish their accounts, and show their premium income, and those with a life department must do so; but in the case of purely fire offices this is not compulsory.

Fire offices may be broadly distinguished as tariff and non-tariff. The tariff are those which belong to the Fire Offices' Committee, an association formed for mutual protection, and, by the regulation of rates, to obviate destructive competition. The non-tariff offices are those which profess to estimate each risk on its merits, without fixing a minimum, but most frequently those offices which try this plan find it unsatisfactory, and subsequently join the tariff. Great Britain is eminently the country of successful fire offices, and several of the British companies are larger than any established in any other part of the world. Many of the British offices transact an enormous foreign business.

Industrial Insurance is the name given where life policies are of small amount, and secured by weekly, or at most monthly, premiums. The premiums vary from 1s. to 3s., or 6d. a week, and it is usual, instead of the premium being adjusted to the age, to adjust the sum assured; so that, while at all ages the premium is the same, the amount of the policy decreases with the age of the life at entry. An

enormous industrial business is transacted in Great Britain, partly by insurance companies and partly by collecting Friendly Societies (q.v.). One industrial company alone—the Prudential, established in 1848—received in industrial premiums in 1889 the huge sum of £3,336,742.

Accident Insurance generally provides for a sum payable in the event of death by accident, or for compensation, either by way of a lump sum or of a weekly allowance, in the event of injury or disablement from accident. Even in early times there are traces of accident business, but the oldest and largest existing accident company is the Railway Passengers', established in 1848. At first, as its name implies, it confined its operations exclusively to railway accidents, and accumulated a premium income of £12,000 a year, but before long it enlarged its powers so as to transact accident business of every description, and in 1896 its premium income was £2,740,000. Besides transacting accident business proper, many of the companies combine with it employers' liability assurance—i.e. they guarantee to refund to employers any damages they may have to pay through accidents to workmen in their service; but without the greatest care this department of the business is unremunerative. Some of the accident companies also issue policies providing weekly compensation in the event of incapacity from illness; but generally it has been found that, on account of the difficulty in defining illness, and on account of the great liability to fraud, sickness insurance has been unprofitable.

Fidelity Guarantee Insurance.—The first attempt at fidelity guarantee insurance appears to have been made in 1720, but it was many years before the business took root. The first fidelity office—'The Guarantee Society'—was established in 1842. The object of fidelity guarantee insurance is to secure employers against fraud on the part of their clerks and servants.

In the *United States of America* an enormous life business is transacted by the native companies, and one of them, the Mutual Insurance Company of New York, is the largest office in the world, while several of the others far surpass in magnitude any British company, except perhaps the Prudential. The premium income of the Mutual of New York in 1889 was £4,745,572, and the new business transacted in that year amounted to £30,310,912—more than ten times that of any British office. The aggregate premium income of the forty leading American offices in 1889 was £28,199,804, while the total premium income of all the ordinary life-assurance companies of the United Kingdom was only £13,928,001. It must, however, be remembered in comparing these figures that three of the American companies—viz. the Mutual of New York, the Equitable of New York, and the New York Life—are almost cosmopolitan in their nature, and transact a gigantic business throughout the civilised world, whereas the great majority of British companies transact but a small foreign business.

American insurance law differs in very many respects from that of Great Britain. The principles have been adopted of strict state supervision, and of a standard of solvency. In each of the states there is an officer charged with the duty of examining into the affairs of insurance companies, of making valuations, and of reporting the results of his investigations; and if the assets are not sufficient to meet the liabilities as legally estimated, the company is compelled to close its doors. As each state of the Union legislates on insurance matters quite independently of all the others, considerable confusion has been produced. In different states different standards of solvency are set up, and it might quite well happen that in one state a company might be adjudged bankrupt, while in

another the commissioner might on the same day give his certificate that it was in a position to meet all its engagements. Practically, however, these anomalies do not cause much inconvenience, and the various states are gradually assimilating their regulations. One principal feature of the American system of transacting business is the Tontine (q.v.) system, which has grown to gigantic proportions. In England, in almost all cases, the surpluses are distributed among the policy-holders by way of immediate bonuses, but in America the great majority of policies are issued on the condition that profits will accrue only if the life survive and if the policy be kept in force for the stipulated period. The effect of this condition is that when profits do vest, they are of course larger than if the policy-holders had received immediate bonuses. In former times not only were the profits placed in a Tontine, but the policies themselves were subject to a similar arrangement; so that unless the renewal premiums were punctually paid, the policies would lapse and the assured would derive no benefit from them.

In the *British colonies* life assurance has also developed in a marvellous manner; and, considering the relative populations, Great Britain is left far behind. The Australian colonies in particular are pre-eminent for the success of their insurance offices, the Australian Mutual Provident Society of Sydney being the largest, and giving perhaps the largest bonuses of any company in the world; this result being due in part to excellent management, but principally to the very high rate of interest which invested funds yield at the Antipodes. On 31st December 1896 the Australian Mutual Provident Society had on its books 128,996 policies assuring £40,623,903, at annual premiums of £1,332,715, and the invested funds amounted to £13,728,540.

While in the Australian colonies insurance laws differ in various respects from those of the United Kingdom, yet they are still further removed from the regulations of the United States of America. There is no standard of solvency, and no government supervision in the ordinary sense of the word; but companies have to make returns somewhat on the British system, so that the public may have full information. In France, Germany, and Austria there are also large insurance companies.

National Insurance.—From an early period the British government has been accustomed to grant annuities on lives, the transactions being carried out by the National Debt Commissioners. The annuity business having been very large and very successful, it was naturally thought that an insurance business providing for sums payable at death might with equal propriety be undertaken, and consequently, through the medium of the post-office, a life-assurance office was started on the 17th April 1865, but in the magnitude of results it has not answered expectations. In the year 1889 the amount received in premiums was only £15,108, 7s. 2d., and the amount paid in claims £7473, 3s. 10d., and the total premium receipts from the opening of the office up to 31st December 1889 were only £226,069, 4s. 8d., being very much less than the revenue of many of the private offices for a single year. Probably the reason for this comparative failure of the British life-assurance department is that no efforts are made to develop the business, and no commission is paid to agents.

New Zealand has also initiated a system of national insurance, but there the practice of private companies has been followed, and with eminent success. Canvassers have been appointed, and commission paid to agents; with the result, that while the department was instituted only in 1874, yet in the year 1896 the premium income was

£790,956, and at the close of that year the accumulated insurance fund amounted to no less than £2,591,342.

Germany is the only country which has attempted compulsory national insurance, and that on a large scale. The first bill was passed in 1883, and provided for the compulsory insurance of workmen against sickness. In 1884 a further act was passed providing compulsory insurance against accidents; and in 1889 a third bill became law under which the working-classes will on disablement from illness or accident, or on attaining old age, receive a pension. It cannot be said that the insurance laws of Germany are based upon strict actuarial science, but they are a bold attempt to solve a very difficult problem. In the United Kingdom there is perhaps not the same need for a compulsory insurance law of this drastic character, because the poor-law practically has the same end in view.

Intaglio (Ital., 'cutting in'), a term in art, the opposite of relief, means the representation of a subject by hollowing it out in a gem or other substance, so that an impression taken from the engraving presents the appearance of a bas-relief. See GEM.

Integral Calculus. See CALCULUS.

Intellect. See PSYCHOLOGY.

Intemperance. See ALCOHOLISM, DELIRIUM TREMENS, INEBRIATES, INTOXICATION.

Intendant, the name given in France before the Revolution to the overseer of a province. Under the complete system of centralisation established by Richelieu these intendants became the mere organs of the royal minister. The National Assembly, in 1789, established in each department an elective administration. Napoleon virtually restored the intendants, but exchanged the hated name for that of *Préfets* (q.v.). Intendant is the name of the person in charge of an estate, and there are *intendants militaires*, *intendants de la marine*, &c.

Inter'calary (Lat. *intercalaris*, 'for insertion'), an epithet applied to those months or days which were occasionally inserted in the calendar to make it correspond with the solar year. See CALENDAR.

Intercommuning. LETTERS OF, was an ancient writ issued by the Scotch Privy-council warning persons not to harbour rebels.

Interdict, an ecclesiastical censure or penalty in the Roman Catholic Church, consisting in the withdrawal of the administration of certain sacraments, of the celebration of public worship, and of the solemn burial-service. Interdicts are of three kinds—*local*, which affect a particular place, and thus comprehend all, without distinction, who reside therein; *personal*, which only affect a person or persons, and which reach this person or persons, and these alone, no matter where found; and *mixed*, which affect both a place and its inhabitants, so that the latter would be bound by the interdict even outside of its purely local limits. The principle on which this ecclesiastical penalty is founded may be traced in the early discipline of public penance, by which penitents were for a time debarred from the sacraments, and from the privilege of presence at the celebration of the eucharist; but it was only in the mediæval period that, owing to circumstances elsewhere explained (see EXCOMMUNICATION), it came into use as an ordinary church censure in the then frequent conflicts of the ecclesiastical and civil power. It was designed to awaken the national conscience to the nature of the crime, by including all alike in the penalty with which it was visited. The most remarkable interdicts are those laid upon Scotland in 1180 by Alexander III.; on Poland by Gregory VII., on occasion of the murder of

Stanislans at the altar; by Innocent III. on France, under Philippe Auguste, in 1200; and on England under John in 1208. The description of England under the last-named interdict, as detailed by some of the contemporary chroniclers, presents a strangely striking picture of the condition of the public mind, which it is difficult with our modern ideas fully to realise or to understand. It would be a great mistake, however, to suppose that during the continuance of an interdict the people were *entirely* destitute of spiritual assistance. The interdict mainly regarded the *solemnities* of public worship; it was permitted to administer baptism, confirmation, and the eucharist in all cases of urgency; to confess and absolve all who were not personally the guilty participators in the crime which the interdict was meant to punish; to celebrate marriage, but without the solemnities; and to confer orders in cases of necessity. And under the popes Gregory IX., Innocent III. and IV., and Boniface III. still further mitigations of its rigour were introduced, one of which was the removal of the interdict and restoration of public worship on certain great festivals, especially Christmas, Easter, Pentecost, Assumption, and All Souls. The Council of Basel enacted very stringent rules as to the use of this penalty, and in later times the general interdict has been entirely disused, although occasionally, in very special circumstances, and to mark the horror of the church for some enormous crime, instances are still recorded in which a particular place or church has been visited with the penalty of a local interdict.

Interdict, in Scots law, is an order issued by the Court of Session to stop or prohibit a person from doing an illegal or wrongful act. The party applying for it must have both title and interest to object to the act complained of—i.e. he must be more than a mere stranger. The principles on which it is granted in Scotland are substantially the same as those in which the parallel Writ of Injunction (q.v.) is granted by the English court.—For *Interdiction*, see FACILITY.

Interest is the consideration paid for the use of money. The interest of £100 for one year is called the rate *per cent.*; the money lent, the principal; and the sum of any principal and its interest, the amount. The current or market rate of interest varies from a variety of causes, the chief of which are the relation existing between the accumulation of money and the demands of borrowers, the prevailing rate of profits on trade, and the security and duration of the loan. In Great Britain the price of the public funds indicates the interest obtainable for a permanent loan with no risk of loss, while the 'bank rate'—i.e. the minimum rate at which the Bank of England will discount bills—represents the interest for temporary loans with less undoubted security. In the former case, as with fixed annuities, the nominal rate of interest never varies; but the real return to the investor depends on the price he has to pay for the capital. Thus, if the price of 2½ per cent. consols be 91½, the actual return will be 3 per cent.

Interest is computed on either of two principles. SIMPLE INTEREST is charged on the principal alone for any length of time. The computation of simple interest is easy, resolving itself into a mere question of proportion; thus, having given the interest on £100 for 1 year, to find the interest on any other sum for any period. Various ingenious devices are made use of to save labour in these calculations, especially by bankers, and are given in most hand-books. COMPOUND INTEREST is the charge made where—the interest not being paid when due—it is added to the principal, forming the amount upon

which the subsequent year's interest is computed. The rules for most readily making computations by compound interest can only be effectively expressed algebraically, and, using i to represent the interest of £1 for one year, and n the number of years, we annex a few of the elementary formulas for £1, from which the result for any sum is obtained by simple multiplication.

(1) *Amount of £1 for a given time at compound interest.*—At the end of the first year the principal (£1) with its interest (i) will become $1 + i$. At the end of the second year the amount will be $(1 + i) + i(1 + i)$, or more simply $(1 + i)^2$, and, generally, *the amount of £1 in n years is $(1 + i)^n$.* Example: To find the amount of £6 in 20 years at 5 per cent. interest. Here i is .05 and n is 20, whence the required amount is $6 \times 1.05^{20} =$ (by logarithms) $6 \times 2.65 =$ £15.18.

(2) *Present value of £1 due n years hence.*—Since £1 becomes $1 + i$ in one year, by proportion $\frac{1}{1 + i}$, otherwise written $(1 + i)^{-1}$ or v , will become £1 in the same time, and hence the present value of £1 due n years hence is $(1 + i)^{-n}$ (or v^n).

At 5 per cent. simple interest a sum of money doubles itself in 20 years, while at compound interest with the same rate it takes less than 15 years. In 100 years £1 at 5 per cent. simple interest becomes £6; at 5 per cent. compound interest it becomes £131, 10s., or thereby.

(3) **ANNUITIES CERTAIN.**—*Amount of an Annuity of £1 in n years.*—At the end of the n years the last year's annuity will be due, and therefore worth £1; the second-last will be worth one year's interest in addition, or $1 + i$; the third (reckoning backwards), $(1 + i)^2$; and so on to the first year's annuity, which will amount to $(1 + i)^{n-1}$. The amount required is therefore the sum of the geometrical series $1 + (1 + i) + (1 + i)^2 + \dots + (1 + i)^{n-1}$; or, $\frac{(1 + i)^n - 1}{i}$.

(4) *Present Value of an Annuity.*—This is easily found from (3), as the result there found must evidently be the present value, improved at compound interest—i.e. multiplied by $(1 + i)^{-n}$. Hence the present value is $\frac{1 - (1 + i)^{-n}}{i}$; or, $\frac{1 - v^n}{i}$.

Tables for the four classes of values above described, based on various rates of interest, are given in most works on annuities and other handbooks; and various useful results, besides those immediately intended, can readily be deduced from them.—The calculation of *Life Annuities* is complicated by the element of the probability of life, and is treated under ANNUITY.

INTEREST, IN LAW.—The charging of interest was formerly looked upon with great disfavour, and was either forbidden or restricted by the Usury Laws (q.v.), which were not finally repealed till 1839. In English law there is no obligation imposed on the debtor to pay any interest whatever, though the sum has been long due and often demanded. The creditor can always sue for his debt, which is his proper remedy, but he derives no benefit from giving time to his debtor. Therefore, if interest is to be paid, this must be, as a general rule, by virtue of express agreement. A tacit agreement, however, would be presumed and given effect to where it could be proved to be a custom between the parties, or the usage of a particular trade to allow interest. Thus, by the usage of merchants, it has always been usual, when an action has been brought to recover the amount of a bill of exchange or promissory note, for the jury to add interest from the time it was due. In the case of money due upon an award by an arbitrator interest is due from the day when the award was

made. Where money is due on a bond also interest is added from the day it ought to have been paid; and if a surety has to pay money for his principal he can recover it back with interest. In all other cases, if there was no express agreement about interest, none could be claimed. By 3 and 4 Will. IV. chap. 42, sec. 28, a jury may now add interest at the ordinary rate on all debts or sums certain, which are made payable under some written instrument at a certain time; and even if not due under a written instrument, then if a written demand has been made, expressly giving notice that interest will be charged from and after the date of the demand if not paid then, interest will also be due. But even in these last cases it is discretionary in the jury to give the interest, and therefore it is not claimable as a matter of course. As regards compound interest, it is *a fortiori* not claimable in any case, except where it has been expressly stipulated for, or where there is in some particular trade a definite custom to pay interest, and such custom must always be proved. The courts generally name 4 per cent. when interest is decreed for, but sometimes 5 per cent.; and where funds have been misapplied the Court of Chancery charges compound interest at 5 per cent. Pawnbrokers are allowed to charge interest not exceeding a fixed sum. See PAWNBROKING.

In Scotland the law has always been much more liberal in allowing interest to be claimed on outstanding debts, for there the converse principle was acted on, that on nearly all debts whatever interest was claimable either by statute or by common law. Thus, interest is due on bills of exchange, on the amount contained in a horning or charge to pay, on sums paid by cautioners, on the price of lands sold, on money advanced at request, on the price of goods sold if the usual time of credit has expired, and generally on all debts when payment is due and has been demanded. In certain cases principal and interest to a fixed date are accumulated into a capital sum on which interest runs; and the House of Lords, on appeal, may give decree for compound interest. The courts charge penal interest at the rate of 20 per cent. against factors and trustees who illegally retain trust funds in their own hands.

In the United States the legal rates of interest vary in the different states and territories, from 5 per cent. in Louisiana to 12 in Wyoming, but in the majority 6 per cent. is the legal rate. In most of the states there are penalties for usury, ranging from forfeiture of the excess of interest to forfeiture of principal and interest. But a higher rate, and in many cases any rate, is allowed by contract.

Interference, in Physical Science, is a term which refers to a very general class of phenomena depending on the co-existence at one place of two different sets of waves, undulations, or vibrations. Its essential character is well illustrated by the mingling of two sets of ripples produced in any way (such as by the dropping in of stones) on the otherwise smooth surface of a sheet of water. Where crest meets crest, and trough meets trough, there the resultant disturbance is increased; but where crest meets trough, and trough meets crest, the disturbance will be diminished, and even annihilated should the mingling ripples be equal to begin with. In such a case we can observe the interference of individual waves. Now, wherever we have wave-motion, in the wide dynamic sense of the term, there we may have interference-phenomena showing themselves. But if, as in the case of the propagation of sound, light, and electrical waves, the undulations are too small, or of a character too peculiar to be *individually* observed or felt by any

of our senses, we cannot hope to have evidence of interference-phenomena unless there is a steady succession of two trains of waves reproducing the same phenomenon at the same place for an indefinite time. Thus, two different rays of light will not in general produce evident interference-phenomena. It is only when they have been brought from the same original source, and made to pursue slightly different paths, that the optical effects of interference are possible. As a simple illustration, take Grimaldi's experiment as modified by Dr Thomas Young (1804), to whom we owe the discovery of the principle of interference and its application to optical phenomena. A ray of light, which for simplicity we shall regard as homogeneous—that is, of one wave-length and colour—is introduced into a darkened chamber through two minute apertures very close together. The two similar divergent rays of light so produced will interfere, and the result, as shown on a screen placed a short distance in front of the apertures, will be a series of bright bands separated by dark spaces. The central bright band, every point of which is equidistant from the apertures, is produced by the superposition of two rays, crest falling with crest, and trough with trough. The next bright band on either side is the locus of all points whose distances from the two apertures differ by a wave-length of light, so that still crest falls with crest, and trough with trough. But at the points that lie in the centre of the intermediate dark space the two rays meet so that crest falls with trough, and trough with crest, and thus produce darkness instead of brightness. The general law is that darkness is produced when the portions of the two interfering rays that coexist at one point were in the original single ray distant from each other by an odd number of half wave-lengths; and that brightness is produced when this distance is an even multiple of a half wave-length. Theoretically an indefinite number of interference bands should be visible; but practically this is not so. The chief reason for the gradual fading of the further bands is the difficulty of obtaining sufficiently pure homogeneous light. If the light is ordinary sunlight it will be found impossible to get really dark spaces, since in this case the component rays, being of different wave-lengths, cannot interfere in the same way. Thus, if the red rays interfere so as to annihilate each other, the blue rays will not do so, but may on the contrary interfere to intensify each other. Hence arise the coloured bands always to be seen when interference-phenomena are produced with non-homogeneous light. Amongst other optical illustrations of the principle of interference we may mention the coronæ round the sun and moon when they are seen through a fleecy cloud, the spurious bows that fringe the primary rainbow, the colours of soap films and thin plates generally, the colours of mother-of-pearl and diffraction gratings (see SPECTRUM), Newton's rings, and, as a simple experiment, the appearance of a candle or lamp flame when looked at through a fine cambric handkerchief. The phenomenon of spring and neap tides (see TIDES) is another case of interference; so also are shadows, both light-shadows and sound-shadows. Moreover, Dr Hertz of Carlsruhe has taught us how to obtain and measure the interference of electro-magnetic waves. See MAGNETISM.

Interglacial Beds. See PLEISTOCENE.

Interim, in the history of the Reformation, the name given to certain edicts of the German emperor for the regulation of religious and ecclesiastical matters 'in the meantime' (Lat. *interim*), till they could be decided by a general council. The chief are the *Ratisbon Interim* (at the diet held at Ratisbon in 1541); the *Augsburg Interim* (diet of

1548); and the *Leipzig Interim* (another diet of 1548). See CHARLES V.

Interlaken ('between the lakes'), a village of Switzerland, in the beautiful valley of the Aar, between Lakes Thun and Brienz. Along the Walnut Avenue or Highway between the lakes there is an almost uninterrupted line of hotels and *pensions*. The village is visited annually by 20,000 to 30,000 tourists, who make it their starting-point for reaching many of the most wonderful sights that the country affords, especially the Bernese Oberland, where are the Staubbach, Lauterbrunnen, the Grindelwald glaciers, &c. Pop. 2121. The nucleus of the village is a former Augustinian monastery (founded 1130).

Interlineations in a deed are additions or corrections written either on the margin or between the lines. In England interlineations in a deed are not fatal, provided only it is proved that they were made before executing the deed. It is usual to put the parties' initials opposite the place where the interlineations occur, in proof of this, or at least by way of memorandum. In affidavits and other documents the initials should also be put at the places interlined. In Scotland interlineations ought to be signed by the parties, and the fact mentioned in the testing clause, otherwise it will be presumed that the interlineations were made after the execution, and will vitiate the deed.

Interlocutor, in Scotch law, means a finding or judgment of a judge or court in a cause.

Interlude, in Music, is a short melodious phrase played by the organist (generally extempore) between the verses of a psalm or hymn tune. It is now in disuse in England. In French cathedrals a long interlude is played between the verses of the *Magnificat*. In the German Protestant Church an interlude (*Zwischenspiel*) is often played between each line of the verse. Examples of its artistic use may be found in Mendelssohn's *Elijah* ('Cast thy burthen') and *St Paul* ('Sleepers, wake').

Intermarriage. See CONSANGUINITY.

Interment. See BURIAL, CEMETERY.

Intermittent Fever. See AGUE.

International, THE. The International Working-men's Association was founded at London in 1864. It was, however, not the first attempt to establish an international combination of workmen. As early as 1839 a number of exiles, chiefly German, had taken part in an unsuccessful rising at Paris, and removing to London had formed a league in the interests of labour. Containing workmen from most of the countries of northern Europe to whom German served as a common tongue, the league naturally assumed an international character. It entered into relation with Karl Marx in 1847, and under his influence was reconstituted under the name of the Communist League. In its name Marx and his friend Fr. Engels drew up the manifesto of the Communist party, an expression of the most violent revolutionary and international socialism. The manifesto was published on the eve of the revolution of 1848, and the members of the league represented the most extreme section of the fighting democracy in Germany during that time of trouble. The failure of the revolution was soon followed by the dissolution of the league.

The association of 1864, usually called the International, began in the visit of some French workmen to the International Exhibition in London, 1862. This visit was encouraged or supported by the Emperor Napoleon. In London the Frenchmen fraternised with their English brethren; wishes for common action in the cause of labour

were interchanged, a course which was furthered by the desire of the emperor, through the workmen, to influence public opinion in favour of Poland. Finally, in September 1864, at a great meeting in London, it was decided to establish an international association of working-men.

Mazzini was first commissioned to draft a constitution for the association, without satisfactory result; and the task fell upon Marx, who, in the inaugural address and in the statutes, embodied the aims of the new movement with masterly force and clearness. Notwithstanding the enormous progress of industry in recent years, Marx contended that the lot of the workmen had not improved; that the economic subjection of the worker under the monopolist of the instruments of labour, that is, of the sources of life, was the cause of servitude, in all its forms, of social misery, intellectual degradation, and political dependence; and that the economic emancipation of the working-class, therefore, was the great end to which every political movement should be subordinated as means. Fearing that the new hopes now awakened might be rendered vain through the want of union, he maintained that the emancipation of the working-class was neither a local nor a national, but a social task, which concerns all countries where modern society exists, and whose solution depends on the practical and theoretical co-operation of the most advanced countries. The association declared that all societies and individuals adhering to it recognise truth, justice, and morality as the rules of their conduct to each other and to all men without distinction of colour, creed, or nationality; no duties without rights, no rights without duties. While intended to act as a centre of combination and systematic co-operation between the workmen of various countries, the International left intact the organisation of existing societies which might join it. There was to be an annual congress, which should name the general council, and the general council would hold in its hands the control of the association.

The statutes drawn up by Marx were adopted by the first congress held at Geneva, 1866; and the socialistic principles which from the first were implied in its constitution received explicit development at that and subsequent congresses, Lausanne (1867), Brussels (1868), Basel (1869). The meeting at Brussels was in every way the most decisive; it declared that mines, land, and means of communication should become the common property of the state, and by it be handed over to associations of working-men to be utilised under conditions favourable to the common good; and that only through co-operative societies and the organisation of mutual credit could the workmen own and control the machines. The congress further condemned all appropriation by capital of rent, profit, or interest; labour should enjoy its full right and entire reward. Against the war then imminent between France and Germany, and against war generally, the congress raised a solemn protest, and recommended a universal strike in the event of its breaking out. At the congress of Basel a proposal for the abolition of the right of inheritance was not carried.

Apart from the meeting of congresses, it is not easy exactly to define the development of the International. Though speedily suppressed by the French government, it had some influence in directing and supporting strikes in that country, while it assisted English trades unions by preventing the importation of cheap labour from the Continent. It had adherents in every country of western and central Europe; but its influence always depended more on the vast and undefined possibilities of the cause it represented than on its

actual strength. Its finances were weak, its organisation loose; the adhesion of many of its members was of a very platonic character. Undoubtedly the most real and effective gain to the International was in Germany, where the workers' unions constituting the Eisenach branch of the Social Democracy declared their adhesion to it.

In 1870 the International proposed to hold its annual congress at Paris, the ancient seat of the revolutionary movement, but the Franco-German war intervened to prevent it. The revolt of the Commune with its disastrous consequences rendered a congress impossible also in 1871. The International had little or nothing to do with originating the Commune; only a few of its members were involved in the rising, and on their individual responsibility. After the suppression of the revolt, Marx in the name of the general council wrote a trenchant manifesto fully endorsing the action of the Commune. He saw in it a rising of the proletariat against a clique of *bourgeois* adventurers who had seized on the central power of France. It was a revolt of the proletariat, the class of which socialism claims to be the special champion; and it was an assertion, against the centralising government of the middle classes, of the political form requisite for the development of socialism, the commune or self-governing local group of workers.

From the first the control of the International had depended mostly on a group of German exiles, of whom Marx was the undoubted chief. The followers of Blanqui and Proudhon exercised some influence, but it could not be compared with that of Marx. In 1869 Bakunin, the apostle of anarchism, with a body of followers entered the International. Naturally they objected to the authority and centralising methods of Marx, and at the Hague congress of 1872 a rupture ensued. The anarchists were expelled from the association, the seat of which was also transferred by the Marx party to New York. In 1873 both parties held congresses at Geneva, which did nothing notable. The Marx International really ceased to exist from that time. The Anarchist International, which was most powerful in the Romance countries, such as Spain and Italy, continued to act for some years subsequently; and particularly it was responsible for the risings in the cities of southern Spain in 1873-74, where the insurgents seized on part of the ironclad fleet, and were suppressed not without difficulty.

No formal organisation styling itself International now exists, but the socialist parties of the different countries, especially those adhering to the Marx school, fully recognise the international character of the movement in which they are engaged. Foremost in every respect among those parties is the German Social Democracy, with its strongly pronounced indifference and even hostility to many of the accepted national interests of the country. Since the downfall of Marx's association international socialism has found expression in congresses, as that of Ghent in 1877. In 1889 the centenary of the Great Revolution, two large international congresses assembled at Paris, one representing the more uncompromising Marx school, the other consisting of delegates who are not indisposed to co-operate with other democratic parties. The proposal made in 1889 by the Swiss government for an international conference on the protection and regulation of labour did not excite much attention; but it was felt that the whole question had entered on a new stage when in the spring of 1890 the German emperor assembled a similar conference at Berlin. It is needless to say, however, that this International of the European governments

concerned itself with only a small portion of the great task undertaken by the association so called. An international demonstration of workmen in favour of the compulsory limitation of the working day to eight hours took place in most populous European and American centres on May 1, 1890 (in London the principal gathering was on Sunday, 4th May).

See Laveleye's *Socialism of To-day*; John Rae, *Contemporary Socialism*; R. Meyer's *Emancipationskampf des vierden Standes* (vol. i. contains the documents bearing on the International); E. Villetard, *Histoire de l'Internationale*.

International Law. Under this designation are included two distinct branches of jurisprudence, known respectively as Public International Law and Private International Law. Public international law regulates the relations of states to states; private international law is concerned exclusively with the legal relations of private individuals, determining by the law of what nation such relations shall be governed in each particular case. Further, it has to be noted that a variety of relations may occur wherein a state and the citizen of another state are the subjects. Here the law is public on one side and private on the other, as is the law administered in prize-courts. In practice, however, such cases are treated under public international law.

Public International Law is the name given to the aggregate of rules which govern the conduct of separate states in their relations to each other. For many years the majority of writers on international law in England and America were content to look for the origin of these rules in no higher source than the more or less general consent of nations, and to base them on no more stable foundation than the shifting sands of expediency. Jurisprudence thus became a merely arbitrary system of rules founded on tacit contracts or express conventions, and its precepts were, logically enough, considered susceptible of any degree of modification, limitation, or adaptation that temporary convenience might seem to demand. These unfortunate doctrines were introduced into English jurisprudence chiefly through the teaching of Bentham, by whom utility was put in the place of natural law. His principles were wrought out and more specifically applied by John Austin, whose works long continued to dominate English jurisprudence. This principle of utility, viewed simply as a good practical test in legislation, or as a ready guide in applying the rules of natural law to the complex facts of state life, may often prove of high value; and, according to Sir H. S. Maine, it was in this aspect, as a 'working rule of legislation,' that Bentham proposed his formula of the 'greatest happiness of the greatest number.' As a matter of fact, however, the majority of the advocates of utility claim that in itself it furnishes the rule of life, and so supplies the place of natural law, the existence of which they deny.

These doctrines have never found much currency on the Continent, and their prevalence in England and America has unfortunately had the effect of cutting off the jurisprudence of these countries from the general stream of scientific jurisprudence which in the nations of continental Europe has continued to run in the old channel. In recent years, however, both in England and America there is observable a growing tendency to abandon this arbitrary notion of positive law. This movement has been largely aided by the scientific spirit, and by the close investigation of nature. Similar researches on the ethical and social sides of human nature have been equally fruitful, with the result that the idea of the universal prevalence of law in all departments of life has been vindicated, and

the faith of mankind in nature as a reasoned organism has been confirmed.

As a science, accordingly, positive international law has for its object the discovery of those laws which determine the relations of nations to each other. In all branches of municipal law, the law of the relations subsisting between citizens is defined and enunciated by a legislative authority, is applied by a judicial authority, and is enforced by an adequate executive. The positive law thus defined is accepted on all hands, and consequently a scientific investigation of natural law is only necessary on those rare occasions when alterations are being made in the enacted law. In the case of international law, in the absence of all legislative, judicial, and executive authority, there really is in the strict sense no positive law at all. There are few even of its central doctrines which are not the subject of warm dispute; the objects to be aimed at are no less undetermined; its history is in many respects fragmentary and inconsistent. The truth is, as Professor Sheldon Amos has remarked, that international law now exhibits a positive system of law in the process of making.

The natural laws governing the relations of nations must have been coeval with the existence of nations. It nevertheless remains true that international law, as a positive system, is substantially the creation of civilised Europe during the last three centuries, and its rules are now practically operative only among civilised states. In spite of the fact that the division of the Greek world into a number of separate communities would seem to us to favour the rise of such a system of law, it would appear that, beyond the recognition of certain common Hellenic customs, no effort was made to systematically enunciate any rules of international intercourse. The glory of Greece was already waning when the Stoics, tracing out in a more ethical and practical direction the principles of Socrates, arrived at the idea of the *persona* and, giving a definite form to the conception of the brotherhood of mankind, enunciated the doctrine of the *jus naturale*. In this doctrine lay the germs of a cosmopolitan system of international law. In Rome the *jus civile* of the early republic—regulating the formal intercourse between Rome and other states—looks like the beginning of what under other conditions might have developed into a system of international law. Unfortunately during the whole period of the empire, while the municipal law of Rome under the influence of the Stoical conceptions was achieving its high destiny, the jurists were by their theory of a universal empire entirely shut out from applying their principles to the relations of states to states. So too, long after the Roman empire had given place to separate kingdoms, while the labours of the civilians contributed largely to the consolidation of the new societies, the imperialistic traditions still lingering among them prevented any effort being made to evolve the doctrines of a *jus inter gentes*. Meanwhile, the peoples of Europe, closely bound in the fetters of an omnipotent feudalism, were painfully struggling through a period of transition, out of which were to emerge the great European monarchies. During this long period the need of some definite system of international law was in some measure practically supplied by two powerful influences—the authority of the church and the institution of chivalry. The magnificent organisation of the church, besides checking violence and controlling in some degree the turbulence of princes, enabled the pope, taking advantage of the lingering notions of universal sovereignty, to act as arbitrator in a great variety of controversies ranging in importance from the disputes of private individuals to the adjustment of difficulties of serious

international concern. The institution of chivalry also, by introducing declarations of war by heralds and a more humane treatment of the vanquished, and generally by inculcating the virtues of fidelity and magnanimity, tended to assuage the horrors of war. Meantime the revival of commerce and the growth of the new commercial cities gave rise to several primitive maritime codes (e.g. the laws of Oleron, the laws of Wisby), whose publication did much to regulate the relations of states in mercantile matters. At length, as the nations of Europe passed into manhood, there came the dawn of a new era and a general rekindling of intellectual life. At the same time the Reformation gave a death-blow to the old notion of a common superior whose decisions were binding upon states, and shattered the influence so long beneficially exercised by the Roman curia as a great court of international appeal. Perplexed by the terrible events of the long struggle between Spain and the revolted Netherlands, and appalled by the unbridled license of the Thirty Years' War, Europe cried aloud for deliverance from what threatened to become international anarchy. The time was ripe for the development of a system of international jurisprudence. The renewed study of Greek philosophy had revived the doctrines of the *jus naturale*, and in the application of these old principles in the new direction of a *jus inter gentes* was found the solution of the problem of international order. The first clear reference to the law of nations, as a separate branch of positive law, and as such distinguishable from the law of nature, is usually found in the work of Francis de Suarez of Granada (1548-1617), *De Lege et Deo Legislatore*. Here, as in the *De Jure Belli* of Alberic Gentilis, though there is no attempt at a detailed system, yet the true character and general objects of the law of nations are very clearly indicated. Of the workers who were thus engaged in applying the law of nature to the relations of states, the greatest and most successful was Hugo Grotius (1583-1645), who combined profound learning and keen philosophic insight with a large experience in public affairs. In his famous work *De Jure Belli ac Pacis* (1625), starting with the conception of a real and determinable law of nature, he wrought out his principles into a detailed and symmetrical system of rules. The success of the work was rapid and decisive, and upon the foundations thus deeply laid by its great founder international law continues securely to rest. Many of his rules indeed have undergone a process of development, and the growth of civilisation has led to the elaboration of large bodies of new rules to meet new wants and changed circumstances, but the authority of the work as a whole remains unshaken. Among the most interesting legal products of our day are the manuals of the laws of war issued by many civilised states to their officers in the field, and perhaps the most singular feature of these manuals is the number of rules adopted in them direct from Grotius.

It remains now to consider what may be called the secondary sources of this branch of jurisprudence, or the means by which positive international law is defined and declared in the concrete relations of states. In all departments of jurisprudence custom or usage is the earliest form in which positive law declares itself. There is, however, a constant tendency for customs to outlive the circumstances in which they arose: it is thus constantly necessary to test the customary rules by the touch-stone of natural law. Further, many of the recognised rules of international law may be traced to the awards given from time to time by arbitrators, the judgments of mixed courts of prize appointed under treaty, and even to such decisions

as are given in courts corresponding to our Court of Admiralty. The great body of rules comprising the maritime law of nations, together with many fundamental rules in other departments, may be found in the decisions of such international tribunals, and thus rest on authority (precedent) as trustworthy as that which commands the homage of the English lawyer. Of such precedents perhaps the most valuable are those furnished by the decisions given in matters of prize by Sir William Scott, Lord Stowell, in his capacity of judge in the Court of Admiralty. To these judgments, which must always form an important part of a course of study on the law of nations, the American Judge Kent (q.v.) has borne this remarkable testimony: 'There is scarcely a decision in the English prize-courts, on any general question of public right, that has not received the express approbation and sanction of our national courts.' A third factor in the formation of positive international law is express convention among states. While treaties during their subsistence constitute between the parties to them the most direct and authoritative declarations of law, yet it is clear that, being merely contracts, they cannot directly bind by their provisions such states as are not signatories. Nevertheless, a series of treaties between different states containing similar stipulations, or even a single treaty whose provisions have been acceded to and acted upon for a length of time by a large number of nations, may have important effects on consuetudinary law, and in this way may materially affect states which have taken no part in the matter. Thus, although the United States have steadfastly refused to adhere to the Declaration of Paris (1856), yet, if the provisions of that treaty continue to be uniformly acted on by the other powers, the obligation on the United States to conform its practice to the rules there embodied will daily become stronger. Considered as sources of international law, the most important treaties are those which profess to declare the absolute law of nations as understood by the contracting parties, such as those abolishing the slave-trade, or defining the relations of belligerents and neutrals. It is, however, in the scientific interpretation of the law as contained in the writings of the great publicists that the most important of these secondary sources of this branch of jurisprudence is to be found. To render clearer our conceptions of the objects of international law, to draw from isolated facts some general principles, to test these principles by the permanent laws of human nature as revealed by the history of events and by the moral and physical sciences, and, further, to apply admitted principles to new sets of circumstances as they arise—to do this and much more has been the work of a long line of eminent jurists, who are at once the witnesses to the law and the guides of its development. By the formation of the 'Institute of International Law' at Ghent in 1873 an attempt has been made to call into existence a new agency for the development of this branch of jurisprudence.

The subjects of international law are sovereign states. In all branches of jurisprudence life is the source of rights, and, therefore, before a community can be regarded as having the rights and being subject to the obligations of a state, it must be shown to possess the essential attributes of state-existence, or, in other words, it must receive political recognition. To the act of recognition a general character is sometimes communicated by several recognising powers simultaneously presenting to the court of the claimant identic notes of recognition, and at the same time giving to their representatives, already some resident as consuls, their credentials of appointment as ministers. Of such a concerted proceeding between states the recognition

of Roumania in 1880 is a recent example. Roughly, we may say that, according to modern conceptions, a state is a politically autonomous aggregate of human beings, having definite relations to territory, to social existence, to government, and to certain moral ideas, of which the ideas of a historic past and a historic future, and of national unity or common interest are the most dominant and unmistakable. During the nineteenth century the tendency has been to lay stress on nationality—a tendency to whose strength the recent unification of Italy and Germany bears eloquent testimony. Nevertheless, although a political community is composed, as Austro-Hungary now is, of very different races of men, or although it consists internally of a union or federation of smaller communities, yet it may be in the eye of international law a single state, provided the whole is subject to one supreme authority. It is, however, essential that, like every juridical entity, the international state, whether great or small, be separate from every other: its moral and physical activity must be peculiarly its own. The fact that recognition thus implies separate existence at once cuts off all colonies, however important and distant from the parent state, and all communities which, though preserving the organisation of a separate nation, are in practice subject to the rule of another state. The fundamental conception of international jurisprudence is that of the interdependence of states, as opposed to their independence. The fact of the reality of such interdependence is every day becoming clearer with the increase of complexity in the social, commercial, and political ties by which the nations of the world are bound one to another. No state, for example, can administer its own criminal law or execute its own criminal judgments without the continual aid of all other states; and in declaring at its Oxford meeting in 1880 that extradition might take place at all times independently of any contractual obligations, or, in other words, that the right of extradition is a right at common law, the Institute of International Law formally accepted the doctrine of the interdependence of states as a conception fundamental in the law of nations.

Questions of the highest importance may arise when a portion of an existing state rises in rebellion, and, setting up a separate government over a considerable portion of the national territories, tenders to other powers a claim for separate recognition. Here again the question is one of fact, depending on the completeness of the new political and military organisation and the probable extent of the conflict by land and sea. The earliest stage of recognition in such cases usually takes the form of a concession of belligerent rights proceeding either from the opposite party in the war or from neutral states alone, or from both. Such belligerent recognition, while it does not confer the peaceful privileges which belong to the perfect state, yet gives all the rights of public war and binds the states which grant it to all the duties of neutrals. The insurgents thus acquire a recognised status: they may capture the goods of their enemies at sea; they can obtain loans of money, and purchase military and naval materials abroad; their flag is acknowledged; and their revenue laws are respected.

In the eye of international law mankind may be said to fall into three spheres, to each of which belong, of right, at the hands of civilised nations, three distinct stages of recognition—plenary political recognition, partial political recognition, and natural or mere human recognition. The sphere of plenary political recognition extends to all the Christian states of Europe and to those states of North and South America originally colonised by

them which have vindicated their independence. By the treaty of Paris in 1856 Turkey was formally admitted to a participation in the advantages of the public law of Europe and the system of concert attached thereto. In spite, however, of this technical recognition the position of the Ottoman empire is still properly only one of partial recognition, in which sphere are also included Persia, China, Japan, and Siam. In the case of Turkey and these other countries, even when diplomatic relations have been established between them and civilised states, the recognition does not extend to their municipal law, either public or private, except as regards their own citizens within their own frontiers. Within the borders of all these states separate courts are maintained, and to these courts is entrusted the decision of questions between the citizens of the western states resident in these eastern countries. The constitution of these consular courts or mixed tribunals varies considerably in different oriental states, and is in most cases regulated by convention. The practice of Great Britain in this respect is still mainly regulated by the Foreign Jurisdiction Act (6 and 7 Vict. chap. 94). The third sphere, that of mere human recognition, extends to the residue of mankind.

All the subsidiary principles which regulate international relations, so long at least as they continue to be normal, are directly deducible as corollaries from the central doctrine of recognition. Thus, since recognition implies capacity for self-support and self-government, each state has the right to choose whatever form of government best suits the people and to exercise without interference all the powers which it possesses. It may establish, alter, or abolish its own municipal constitution, discover and settle new countries, extend its navigation and fisheries, improve its revenues, arts, agriculture, and commerce, increase its military and naval forces, and develop its national resources by all innocent and lawful means. This fundamental rule that the juridical attitude of states is normally one of mutual confidence, and that the highest political wisdom consists in allowing to each nation entire freedom to manage its own internal affairs and to develop spontaneously its natural resources, negatives the principle of the Balance of Power, now practically obsolete.

As regards proprietary rights, each state is owner of the whole area included within definite boundaries, ascertained by occupation, prescription, or treaty. All ports, bays, mouths of rivers, and a strip of sea three miles in width bordering on the coast-line are included within the territory of the state. In this way each state is enabled more perfectly to carry into effect its maritime laws and customs regulations, to provide for an adequate system of coast defence, and to secure, as long as it remains neutral, immunity from all acts of belligerency between the ships of the enemy. Where, however, part of the territorial waters, so defined, consists of a channel of communication between two portions of the open sea, all vessels of friendly states have the right of free passage. The position of interoceanic canals in international law is not yet quite settled, but the tendency seems to be in favour of the neutralisation of such canals under an international guarantee, so that they may be at all times open to the ships of every nation for the purposes of peaceful passage.

Within its territorial limits each state is entitled to the exclusive power of legislation in respect to the personal rights and civil status of its citizens, and in respect to all real and personal property, whether belonging to citizens or aliens. In recognising the state, other nations recognise its legislative capacity, and consequently are bound, not only to allow it to administer its own municipal law

without interference within its own limits, but also to accept as valid and give effect to the definitions of private rights contained in that municipal law. That part of the municipal legislation of a state which deals with the public relations of citizens is in a different position, and is not recognised as valid within the jurisdiction of other states. Thus, for example, a peer of the United Kingdom carries with him, when he goes abroad, none of the privileges peculiar to his peerage; but as to his private relations—whether he is married or single, a debtor or a creditor, a major or a minor—the continental states in which he is sojourning accept and give effect to what English law says regarding them. So the judgments of the judicial tribunals of a recognised state ought to be, and in practice generally are, accepted without question by foreign states, provided only their validity in the country in which they were pronounced is established. Such foreign judgments are, however, executed within the territory of the recognising state only under the authority and by the order of the native tribunals, and thus the form and manner of execution are exclusively governed by the law of the executing state. With regard to crimes, each state administers its own criminal laws within its territories to foreigners and natives alike. Further than this, each state is bound by the principle of recognition, and consequently by the common law of nations, to aid other states in administering their criminal laws and executing their criminal judgments. Thus the right of each state to demand from other states the surrender of an individual accused of having committed a crime within its territory is a right at common law. To this rule political offences form an exception, inasmuch as they do not partake of the universal character attaching to other crimes. The matter is generally regulated by extradition treaties, in which are usually contained stipulations to the effect that no one will be surrendered unless *prima facie* evidence of his guilt is furnished, and unless adequate assurances are given that the accused will not on that occasion be tried for any offence other than the crime for which he is surrendered. The civil and criminal jurisdiction of a state extends to all its ships on the high-seas or within its territorial waters, and to its public vessels everywhere. When a private ship enters a foreign port, it becomes subject to the 'concurrent jurisdiction' of its own state and of the country in whose territorial waters it lies for the time. Considerable light was thrown upon the exact character and extent of the jurisdiction of a state over that portion of the sea within the three-mile limit by the case of the *Frugonia* (*Regina v. Keyn*, 2 Exch. Div. pp. 202-205). In that case the majority of the court held that, as the law of England stood at that time, the English courts had no jurisdiction over a criminal offence committed by a foreigner on board a foreign ship which was on the open sea but within three miles of the English coasts. In consequence of this decision the Territorial Waters Jurisdiction Act (40 and 41 Viet. chap. 73) was passed, conferring jurisdiction in such cases upon the Courts of Admiralty. To the rule that the jurisdiction of a state extends over all persons and things within its territory the following exceptions are taken—foreign sovereigns and their suites, when visiting a country in their official capacity, diplomatic agents of other states, and public armed forces of a foreign nation passing peacefully through the state territory. The exemption of the citizens of the western European states from the local jurisdiction in eastern countries cannot be considered an exception, inasmuch as these latter countries are only partially recognised, and consequently the principles deduced from plenary recognition are in their case inapplicable.

Private International Law is that department of national law which arises from the fact that there are in the world different territorial jurisdictions possessing different laws. The subjects of this branch of jurisprudence are private individuals, and its rules are administered by municipal courts. The majority of the relations in which human beings stand to each other are in their nature universal, and entirely independent of the states to which the parties belong. Thus an individual may possess real property in a state other than that of his domicile, or he may enter into a contract or execute a testament in a country different from either. As, in general, each of these countries is governed by a distinct system of laws, it is frequently a question under which system the particular relations fall. In the event of an action becoming necessary, is he to appeal to the municipal laws of his native country or domicile, or to that of the place in which the property is situated, or to that in which the contract was entered into, or in which the testament was executed? The whole of the doctrines of private international law accordingly resolve themselves into the single doctrine of the localisation of such legal relations. This branch of law determines no legal relations whatever; it simply says by what system they shall be determined. It is a doctrine of jurisdiction, and nothing more. The collection of rules for thus determining by what system of municipal law each legal relation is governed was usually, till recently, known as the 'conflict of laws'—a title justly censured as expressing a limited and unsound view of this branch of jurisprudence.

According to the famous rules of Foelix and Huber, which were long accepted as the fundamental propositions on which private international law was founded, all the effects which foreign laws can produce within the territory of any nation depend absolutely on the consent of that nation, either express or tacit. The sole foundation for the whole system was found in the voluntary and reciprocal good-will of nations (*comitas gentium*). After being abandoned by the majority of continental jurists, this view was formally repudiated by the Institute of International Law at Geneva in 1874. The whole principle of this branch of law is nothing more than a direct corollary from the doctrine of recognition. The right and duty of mutual confidence involved in the doctrine of recognition imply, as we have seen, the acceptance and enforcement by the recognising state of the definitions which the recognised state may have imposed on legal relations—and this, as a rule, even when the definitions so imposed differ from those which are applied to the same legal relations when existing among its own citizens. In this aspect private international law rests not upon the right of the state which concedes it, but on that of the state to which it is conceded.

The increasing intercourse between individuals of different nations gives a growing importance to the interests affected by this branch of law—the rules being accepted and enforced by the various states as part and parcel of their local law. The rights and obligations which result to persons from the possession of immovables are entirely regulated by the law of the country where the immovable subjects are situated. This *lex loci rei sitæ*, as it is called, determines, even in the case of an alien proprietor, all questions relating to the acquisition of immovables, whether by sale or prescription, to feu-duties, to letting, hiring, and mortgaging, working of mines and minerals, servitudes, and to all taxes and public burdens. The law of the place where real property is situated in short governs exclusively as to the tenure, the title, and the descent of such property. In England and America

the *lex loci rei sita* is also applied to determine the legal capacity of the alien proprietor, in so far as depends on his personal status, for example, the age at which he can acquire, alienate, or succeed to immovables. In Scotland and in most continental countries the capacity to acquire or alienate immovable property is regulated by the law of the domicile of the owner, by which all matters relating to status are exclusively governed. In nearly all European countries the rule long obtained that the tenure of immovable property was only possible to a foreigner on the condition of political naturalisation. In almost all states this rule has now been relaxed; and in Britain it has been entirely departed from under the Naturalisation Act of 1870 (33, 34 Viet. chap. 14, sect. 2), which provides: 'Real and personal property of every description may be taken, acquired, held, and disposed of by an alien in the same manner in all respects as by a natural-born British subject; and a title to real and personal property of every description may be derived through, from, or in succession to an alien, in the same manner in all respects as through, from, or in succession to a natural-born British subject.' On the other hand, all movable and personal property is governed by the law of the domicile (*lex domicilii*). Domicile is defined by Westlake to be the 'legal conception of residence,' and is made up of various elements of birth, citizenship, &c. This law of the domicile also regulates all questions regarding personal status, legitimacy, and succession to movable property. If a question arises about a contract, its validity and interpretation are determined by the law of the country in which the contract was entered into (*lex loci contractus*). Thus, if a marriage is valid by the law of the place where it was made, it is, generally speaking, valid everywhere else. Wherever, from the nature of the contract itself, or the law of the place where it is made, or the expressed intention of the parties, the contract is to be executed in another country, everything which concerns its execution is to be determined by the law of that country. Again, all questions as to the admissibility and value of evidence or as to procedure or remedy are determined by the laws in force at the forum in which an action is raised (*lex fori*). If a contract made in one country is attempted to be enforced in the judicial tribunals of another, all questions of prescription are to be determined by the law of the state where the suit is pending. Such at least was the view taken in the famous case *Don c. Lippmann*, though Savigny, Westlake, Bar, and others argue strongly that this is a matter which ought to be decided by the law of the place where the contract was made.

Reference may also be made to the following articles as bearing on international law:

Alien.	Enemy.	Naturalisation.
Ambassador.	Extradition.	Neutrality.
Arbitration.	Foreign Enlistment.	Paris (Treaty of).
Balance of Power.	Foreign Law.	Piracy.
Blockade.	Geneva Convention.	Political Offences.
Capitulation.	Grotius.	Prisoners of War.
Conflict of Laws.	Immigration.	Privateer.
Consul.	Jurisdiction.	Prize.
Contraband.	Jurisprudence.	Siege (State of).
Diplomacy.	Law.	Treaty.
Domicile.	Marriage.	War.

BIBLIOGRAPHY.—Public International Law: Hugo Grotius, *De Jure Belli ac Pacis* (Paris, 1625; Whewell's Eng. ed. 1833); Vattel, *The Law of Nations* (Chitty's Eng. ed. 1797); Bluntschli, *Das moderne Völkerrecht* (Leip. 1877) and *Le Droit International Contemporain* (Paris, 1874); Kent's *Commentaries* (Aldy's ed. Lond. 1878); Wheaton's *Elements of International Law* (Dana's ed. Boston, 1866; Boyd's ed. Lond. 1878) and *History of the Law of Nations* (New York, 1868); Phillimore, *International Law* (4 vols. 2d ed. 1871); W. Oke Manning, *Commentaries on Law of Nations* (Sheldon Amos's ed. Lond. 1875); W. E. Hall, *International Law* (Oxford,

1880); Lorimer, *Institutes of the Law of Nations* (1884); and the works by Westlake (1895) and Lawrence (1896).

Private International Law: Savigny's *System*, &c. vol. viii. (Eng. trans. by William Guthrie, with notes and appendixes); Story's *Conflict of Laws* (new ed. Boston, 1883); Westlake's *International Law* (new ed. 1880); Bar's *International Law* (Eng. trans. by G. R. Gillespie, 1883); Horace Nelson, *Selected Cases, Statutes, and Orders* (1889); A. V. Dicey, *Law of Domicile* (1879); Pitt Cobbett, *Leading Cases and Opinions on International Law* (1885).

Interpleader is a form of process in the English courts intended for the protection of a defendant who claims no interest in the subject-matter of a suit, while at the same time he has reason to know that the plaintiff's title is disputed by some other claimant. In such a case the defendant may apply to a judge, who will order the plaintiff and the other claimant to appear and interplead. An application of this kind may now be made in any action in the High Court. Special protection is given to sheriffs, &c. when goods taken in execution are claimed by a third party.

Interpretation. See EXEGESIS.

Interpreter. See DRAGMAN.

Interval, in Music, is the difference of pitch between any two musical tones. Since pitch depends upon the vibration-frequencies, the relation between any two pitches is the numerical ratio between the two vibration-frequencies; and all pairs of tones within which the frequencies have the same ratios present equal intervals. The interval between any two tones, whether chosen or heard at random, is thus expressible as an arithmetical ratio; but musically it is only certain intervals which are recognised as being musical intervals, and what these are depends upon the Scale (q.v.) which is in use. Among the European nations and those of European descent the diatonic scale is employed; and this, when unmodified by Temperament (q.v.), presents the ratios given under Harmonics (q.v.). Within such a scale the various intervals that may be found are (C being taken to represent the keynote of the scale) minor second (= E—F or B—C') = 16/15; grave major second (= D—E or G—A) = 10/9; major second (= C—D, F—G, A—B) = 9/8; grave minor third (= D—F) = 32/27; minor third (= E—G, A—C', B—D') = 6/5; major third (= C—E, F—A, or G—B) = 5/4; perfect fourth (= C—F, D—G, E—A, G—C', or B—E') = 4/3; acute fourth (= A—D') = 27/20; acute augmented fourth (= F—B) = 45/32; grave diminished fifth (= B—F') = 64/45; grave fifth (= D—A) = 40/27; perfect fifth (= C—G, E—B, F—C', G—D', A—E') = 3/2; minor sixth (E—C', A—F', B—G') = 8/5; major sixth (= C—A, D—B, G—E') = 5/3; acute major sixth (= F—D') = 27/16; grave minor seventh (D—C', G—F', B—A') = 16/9; minor seventh (E—D', A—G') = 9/5; seventh (C—B, F—E') = 15/8; octave (C—C', D—D', &c.) = 2/1. By taking various notes of the diatonic scale as starting-points, and measuring known intervals from these, we arrive at intermediate notes of the scale, of which the following are examples, the vibration-ratios being given with reference to C':

	Vibration-ratios.
C; minor third below E.	25/24 = 1.0416
D \flat (as A; D; c; A \flat ; D \flat).	27/25 = 1.0800
D \sharp ; minor second below E.	75/64 = 1.1672
E \sharp ; minor third above C.	6/5 = 1.2000
A \flat ; minor sixth above C.	8/5 = 1.6000
B \flat ; minor seventh above C.	9/5 = 1.8000
B \sharp ; 3 major thirds above C.	125/64 = 1.9531

The difference of pitch between C and C \sharp or between D and D \flat is frequently called a semitone, and an interval increased or diminished by a semitone is said to be augmented or diminished. This applies especially to the interval of a fourth or a fifth,

which with the octave are said to be perfect, because any augmentation or diminution mars their consonance. The major sixth or third may however be diminished to a 'minor' sixth or third without destroying the consonance; and the term 'minor' is also applied to the diminished second or seventh. The octave begins a new series, and thus the 'ninth' is the octave of the second, and so forth. For further discussion of the musical nomenclature, which is somewhat unsettled, see article 'Interval' in Grove's *Dictionary of Music and Musicians*; and for a numerical table of the various intermediate tones within the scale, see Daniell's *Principles of Physics*, 2d ed. pp. 390-91.

Intestacy. the state of a person who has died without testing—i.e. without leaving a will. If no will, or deed equivalent to a will, is executed, or if a will executed is invalid from defect of form, then an intestacy occurs, and the law provides an heir or next of kin, in lieu of the owner himself doing so. See HEIR.

Intestines. a part of the digestive system, divided into the smaller intestine (comprising duodenum, jejunum, and ileum) and the greater intestine. See DIGESTION, Vol. III. pp. 814, 815; GUT; and for Diseases, see CONSTIPATION, DIARRHŒA, DYSENTERY, ENTERITIS, PERITONITIS, &c.

Intimidation. See THREAT.

Intonation. The opening phrase of any plain-song melody, sung usually either by the officiating priest alone, or by one or more selected choristers. The term is most commonly applied to the first member (consisting of two or three notes) of a Gregorian Psalm tone, the other members of it being the *dominant* (or reciting-note), the *mediation*, and the *ending*. Its use is confined usually to the first verse of the psalm or canticle, except in the case of the *Magnificat*, *Benedictus*, and *Venite*, to give greater solemnity to which it recurs in each successive verse.

Intoning. a modern popular term for the utterance in musical recitative of the versicles, responses, collects, &c. of the Anglican Liturgy. This recitative consists mainly of a single sustained note, or *monotone*, but may be varied by the introduction of certain simple inflections, which have the sanction of more or less prevalent custom or tradition. Of these a full account may be found in various choral books—e.g. in Doran and Nottingham's *Choir Directory of Plain-song*, Doran and Thompson's *Ritual Music of the Altar* (both published by Novello), and in *Notes on Ceremonial* (Pickering).

Such musical recitative in vocal prayer is undoubtedly very ancient, and its employment in Christian worship is, in fact, an inheritance from the Synagogue, where it may be heard still. It obtains equally among Mohammedans, American Indians, South Sea Islanders, and the great majority of barbarous nations, and would seem to be the outcome of an instinctive feeling that the familiarity of our colloquial tones of voice is out of keeping with the reverence that befits human intercourse with Deity. Whatever may be said for or against the practice elsewhere, there can be no doubt that in our cathedrals and larger sacred buildings an audible utterance would without it be far less easily attainable.

Intoxication. This term is applied to the condition brought about by an overdose of alcohol. The symptoms induced vary a good deal according to the rapidity with which the alcohol is drunk and absorbed into the blood, and also according to the form—spirits, wine, or beer—in which it is taken. If they are swallowed rapidly in large quantities the symptoms are those of a narcotic poison. See ALCOHOL, ALCOHOLISM, POISON.

Intoxication, or drunkenness, is, in point of law, no excuse for any wrong done by the drunken party. Crimes which are committed in a state of drunkenness are punishable in the same way as if the actor were sober, though it is discretionary in the court to mitigate the sentence. A contract made when the parties, or either of them, are in a state of complete incapacity from intoxication may be made void. So it is when one of the parties is intoxicated, and a sober person induces his consent by fraud. Thus, if goods are sold to a person so drunk that he does not know what he is doing, the purchase may be repudiated as soon as the drunk man becomes sober. Unless he does so immediately on coming to his senses, however, the contract will stand. The drunk man, in short, may either repudiate or enforce the bargain when he comes to his senses. The mere act or state of drunkenness, when privately indulged in, is not an offence against the law; but if it be shown in public it may become so. Every person found drunk in a highway or public place, or in a licensed house, is liable to a penalty of ten shillings; and on a second offence within twelve months, to twenty shillings, and on a third offence within twelve months, to forty shillings. To be drunk and riotous, or be drunk while in charge of a horse or carriage, or of a gun, is punishable with a fine of twenty shillings, or imprisonment for one month. Local acts also often impose other penalties. In Scotland several ancient statutes were passed against drunkenness, which, however, are in desuetude. In many local police acts a penalty is imposed on drunkenness in the streets.

Intransigents, or INTRANSIGENTES (*Irreconcilables*), a name sometimes given to the extreme political parties opposed to the existing government in Italy, Spain, and France; as, for instance, the revolutionary communists in Spain in 1873. For the connection of these last with the anarchistic party, see INTERNATIONAL.

Intrenchments. See ENTRENCHMENTS.

Introduction (Ital. *introduzione*), in Music, is a kind of preface or prelude to a following movement. Formerly the introduction was only to be found in large musical works, such as symphonies, overtures, oratorios, &c.; but now it is found in every rondo, fantasia, polonaise, waltz, &c., on the principle that it is considered abrupt to begin all at once, without preparing the audience for what is to come. In earlier operas introduction is applied to the piece of music with which they begin, and which immediately follows the overture. In some cases the overture and introduction are united, the composition going on without any formal pause, as in Gluck's *Iphigénie en Tauride*, Mozart's *Idoménée* and *Don Giovanni*. Overtures themselves are frequently commenced by an introduction, as in Beethoven's *Egmont* and *Leonora*, Nos. 2 and 3, and Weber's *Freischütz*; and *Oberon* overtures. The majority of Wagner's operas commence with an introduction (*Vorspiel* or *Einführung*), a short one being also prefaced to the second and third acts. The introductions are also important and characteristic parts of several of the symphonies of Beethoven and Schumann.

Introit, in the Roman Catholic Church, an anthem sung at the beginning of the mass, immediately after the *Congitor*, and when the priest has ascended to the altar. It consists of an antiphon, Gloria Patri, and usually part of a psalm; but other passages of Scripture are used, while a few introits in the present Missal are taken from uninspired writers, and one (Whit-sunday) is from 2d Esdras. The introduction of introits is ascribed to Gregory the Great (595), or perhaps to Celestine (423). In the first prayer-book of Edward VI.

an introit is prefixed to each collect, consisting of a psalm to be sung after the opening prayer in the communion office.

Intromission. in Scotch law, is the assumption of authority to deal with another's property. It is divided into legal and vicious. Legal intromission is where the party is expressly or impliedly authorised, either by judgment or deed, to interfere, as by drawing the rents or getting in debts. Vicious intromission is where an heir or next of kin, without any authority, interferes with a deceased person's estate; as, for example, where a person not named by a will, or without the authority of any will, collects the property of the deceased person as if he were regularly appointed. By so doing the vicious intromitter incurs the responsibility of paying all the debts of the deceased. The viciousity, however, may be taken off by the intromitter being regularly confirmed executor. The corresponding phrase in England to a vicious intromitter is an *executor de son tort*.

Intuition. See COMMON SENSE, A PRIORI, LOCKE, REID, ETHICS, PSYCHOLOGY.

Intus-susception. or INVAGINATION, is the term applied to the partial displacement of the bowel in which one portion of it passes into the portion immediately adjacent to it, just as one part of the finger of a glove is sometimes pulled into an adjacent part in the act of withdrawing the hand. In this case the contained portion of intestine is liable to be nipped and strangulated by the portion which contains it, and all the danger of Hernia (q.v.) results, with far less chance of successful interference on the part of the surgeon or physician. It is one of the most frequent and fatal causes of obstruction of the bowels in children, but less common in adults. The extent of the intus-susception may vary from a few lines to a foot or more. Even when inflammation is set up, the affection, although in the highest degree perilous, is not of necessity fatal. The invaginated portion mortifies and sloughs, while adhesion is established between the peritoneal surfaces of the upper and lower portions at their place of junction, so that the continuity of the tube is preserved, although a large portion may be destroyed. If the patient is strong enough to bear the shock of the inflammation, gangrene, sloughing, &c., a complete recovery may ensue, though such a termination is rare. In the early stage the normal condition may often be restored by large enemata of air or water. Of late some success has attended operation where simple measures have failed. For Volvulus, see COLIC.

Inulin, a vegetable principle, isomeric with starch, derived from Elecampane (q.v.).

Invalides. HOTEL DES. See PARIS.

Invaliding signifies the return home, or to a more healthy climate, of soldiers or sailors who have been rendered incapable of active duty by wounds or the severity of foreign service. The man invalided returns to his duty if his health is sufficiently restored to justify the step, otherwise he is discharged as 'medically unfit.'

Invention. See PATENT.

Inventions and Discoveries. The following list purports to give only a few of the more important inventions and discoveries, chiefly such as have exercised a determining influence upon the civilisation of the world. The principal geographical discoveries have been already discussed under GEOGRAPHY. For other information, see Beckmann's *History of Inventions, Discoveries, and Origins* (new ed. 1888).

Mariner's Compass, invented in Europe in the 12th century, although known and used for centuries previously in China.
Gunpowder, by Schwarz about 1320 (see GUNPOWDER).
Printing, by Johann Gutenberg, about 1440 (see PRINTING).
Copernican System, in 1543 by Copernicus (q.v.).
Microscope, by Hans and Zacharias Janssen, or Zausz of Middelburg, about 1590.
Circulation of the Blood, by Harvey, in 1616.
Electricity, name invented and knowledge of advanced by W. Gilbert, 1651; induced electricity discovered in 1831 and its relation to magnetism shown in 1819 by Oersted and in 1835 by Faraday.
Law of Gravitation, by Newton, 1682.
Steam-engine, by Newcomen in 1705, and by Watt in 1766.
Pianoforte, by Cristofori of Florence, before 1720.
Clock, used in Europe in the 11th century. Chronometer, by John Harrison, 1762.
Spinning-jenny, by Hargreaves, in 1767.
Balloons used by Montgolfier, 1782-83.
Weaving-loom, by Cartwright, in 1785.
Gas-lighting, by William Murdoch, in 1792, at Redruth in Cornwall.
Vaccination, by Jenner, in 1796.
Steamboat proved practically useful, by Fulton on the Hudson, 1807.
Locomotive on railway, by George Stephenson, in 1814.
Moor's safety-lamp, by Davy, in 1816.
Photography, by Nièpce, in 1825.
Electric Telegraph, by Morse, 1835, and by Wheatstone and Cooke, 1834-37 (see TELEGRAPH).
Penny Postage, by Sir Rowland Hill, 1840.
Sewing-machine, by Elias Howe, 1841.
Chloroform, used as an anæsthetic by Simpson in 1848.
Evolution Theory, by Darwin and Wallace, in 1858.
Spectrum Analysis, by Kirchhoff and Bunsen, 1860.
Telephone (q.v.) in 1800-76.
Photograph, by Edison, in 1889.
Röntgen Rays, by Röntgen, at Würzburg, in 1895.
Argon (1895), followed by Krypton, Neon, Metargon, Coronium, Mollium (1898).

Inventory. in England a list of a deceased person's effects made by an executor. In Scotland it is also used in reference to the property of an infant, pupil, or minor whose estate is under the care of a guardian, tutor, curator, or judicial factor. In Scotland it is also used in connection with the various pleadings and deeds and documents produced or used in a suit or action, then called an inventory of process. So as to an inventory of titles—i.e. the titles of an estate shown to a purchaser.

Inveraray, the county town of Argyllshire, is picturesquely seated on the north-west shore of Loch Fyne, 16 miles SSW. of Dalnally station, and 45 NNW. of Greenock (*viz.* Loch Eck). Removed to its present site in 1742, it has a sculptured stone cross from Iona (*c.* 1400), and an obelisk to the memory of seventeen Campbells, executed here without trial in 1685 for their share in Argyll's expedition. Inveraray Castle, the seat of the Duke of Argyll (q.v.), was rebuilt in 1744-61. A royal burgh since 1648, Inveraray with Ayr, &c. returns a member to parliament. Pop. (1841) 1233; (1891) 743.

Invercargill, a town in the province of Otago, New Zealand, capital of the county of Southland, stands on an estuary called the New River Harbour, 139 miles by rail SW. of Dunedin. It is regularly built, with fine wide streets, gas, and steam trams, and is unusually well provided with public parks. Besides the government buildings and schools and churches, it possesses an excellent athænaum and a hospital. There are some thirty sawmills in and around the town, besides foundries, steam flour-mills, breweries, and manufactures of boots, bacon, cordials, &c. There are extensive meat-freezing works at the mouth of the estuary, and much Southland mutton is now sent to England; other exports from Invercargill are wool, grain, cheese, and timber. Pop. 7962.

Inverkeithing, a royal burgh of Fife, at the head of Inverkeithing Bay, 13 miles WNW. of Edinburgh. With Stirling, &c., it returns one member to parliament. Pop. 1676.

Inverlochty, a ruined castle of Inverness-shire, 2 miles NE. of Fort William, near which on

Sunday, 2d February 1645, Montrose completely routed his rival, Argyll.

Inverness, the county town of Inverness-shire, and capital of the northern Highlands, stands on the Ness, near its mouth in the Moray Firth and the north-east end of the Caledonian Canal, 108 miles by rail WNW. of Aberdeen, 144 NNW. of Perth, and 190 NNW. of Edinburgh. Its wooded environs, hemmed in by hills (Tounahurich, 223 feet; Torvean, 300; Craigphadrick, 130; Dunean, 940, &c.), form a picturesque and interesting landscape. Visited by Columba (q.v.) about 565, and by Malcolm Canmore made the seat of a royal castle, by Cromwell of a citadel (1652), Inverness has a wealth of memories. It was garrisoned by the English in 1296; in 1441 was burned by Donald of the Isles on his way to Harlaw; and figures repeatedly in the history of the Stuarts, down to their final overthrow at Culloden, hard by. In front of the Scots-Flemish town-hall (1882), protected now by a fountain, is the Clach-na-Cudain, or 'stone of the tubs,' the palladium of the burgh. The Episcopal cathedral (1867) of the united diocese of Moray, Ross, and Caithness is a fine Decorated edifice; and other features of the place are the county hall (1835) on the site of the castle, the infirmary (1804), the lunatic asylum (1860), the royal academy (1792), the barracks (1884), the main suspension bridge (1855), and the Islands, a favourite promenade. Malting, thread-making, and bleaching have given place to woollen manufacture, shipbuilding, distilling, &c., with considerable shipping and commerce, the harbour having been much improved in 1847. The great wool fair (established in 1817) is held in July; and the Northern Meeting (1788) in September. A royal burgh since about 1067, Inverness unites with Forres, Fortrose, and Nairn to return one member to parliament. Pop. (1831) 9663; (1881) 17,365; (1891) 29,855, of whom 6356 were Gaelic-speaking, though Inverness still is famous, as in Defoe's and Dr Johnson's day, for the purity of its English. See two books by Fraser Mackintosh (1865-75), Miss Anderson's *Inverness before Railways* (1885), and *Mémorabilia of Inverness* (1887).

Inverness-shire, a Highland county, the largest in Scotland, and larger than any in England but Yorkshire, stretches from sea to sea, and has a total area of 4323 sq. m., of which 1284 belong to the Outer Hebrides—Skye, Harris, North and South Uist, Benbecula, Barra, Raasay, Eigg, St Kilda, and thirty-seven other inhabited islands. The mainland portion, measuring 83 by 55 miles, is intersected NE. and SW. by the Great Glen and the Caledonian Canal (q.v.). It includes Badenoch, Glenroy, and the valley of the Spey on the east; Lochaber on the south; Glenelg, Glengarry, Arasaig, and Moidart on the west; Strathglass on the north; Glenurquhart and Glenmoriston towards the centre. It is truly a 'land of the mountain and the flood,' for it contains Ben Nevis (4406 feet), the highest point in Britain, with twenty-six other summits exceeding 3500 feet, whilst the chief of its rivers are the Spey, Ness, and Beauly, and of ninety good-sized lakes Lochs Ness, Archaig, Shiel, Lochy, Monar, Laggan, and Eriocht. The west coast is indented by salt-water Lochs Hourn, Nevis, and Moidart. The rocks include gneiss, mica-slate, granite, porphyry, and trap; and the most fertile soil in the county rests on the red sandstone in the valley of the Aird, and between the county town and Beauly. Only 4.6 per cent. of the whole area is in cultivation; and 255 sq. m. are under wood, the rest being sheep-walks, deer-forests, moss, and barren heath, valuable only as grouse moors. Sheep, numbering some 700,000, are the principal live-stock; and there are five deer-forests of 50 sq. m. and

upwards. The rivers and lakes afford splendid fishing, and in 1890 the total rental of the shootings, deer-forests, and fishings of Inverness-shire was £86,902. The land is mostly divided among eighty-nine proprietors, eight holding each above 100,000 acres. The county returns one member to parliament. Inverness is its only town of any size; Kingussie and Fort William, though police burghs, are mere villages, as also are Beauly, Fort Augustus, and Portree. Pop. (1801) 72,672; (1841) 97,799; (1881) 90,454; (1891) 90,121, less than 21 inhabitants per square mile. See articles on the chief islands, lakes, &c., as well as on HIGHLANDS, HEBRIDES, CULLODEN, DEER-FORESTS, GLENROY, and FOYERS.

Inversion, in Music, is of three kinds. (1) Of a chord, when any other of its component notes than the root is placed lowest (see HARMONY). (2) Of an interval (within the octave), when the lower note is transposed an octave higher, or *vice versa*. To find what an interval becomes by inversion, subtract the figure denoting it from the figure nine; thus, a second inverted becomes a seventh, a third becomes a sixth, &c. In this change major intervals become minor, augmented intervals become diminished, and *vice versa*. (3) Of a subject or theme, when it is imitated in contrary motion—i.e. the melody progresses by the same intervals as the original theme, but ascends or descends always in a contrary direction. This is a frequent device in fugues and other contrapuntal music.

Invertebrata, a collective title for those animals which agree in *not* exhibiting the characteristics of Vertebrates—viz. a dorsal nerve cord, a dorsal median supporting axis or notochord, respiratory clefts on the pharynx, a ventral heart, and eyes arising for the most part as out-growths of the brain. But the dividing line is no longer so clear as it once seemed, for not only are Ascidians or Tunicata recognised as degenerate Vertebrate or Chordate animals, but several 'worm' types, among Nemerteans and Chaetopods, approach Vertebrates in some of their characters, while Balanoglossus (q.v.) and Cephalodiscus (q.v.) are so near the boundary line that they are usually called Hemi-chordata or half Vertebrates.

Invertebrate animals are first divided into (1) Protozoa—uni-cellular—and (2) Metazoa—multi-cellular. The latter then fall into two distinct divisions: (*a*) without body-cavities—Sponges and Coelenterates—and (*b*) with more or less of a body-cavity—the Coelomata. Among the latter starfish, &c. (without including Vertebrates), the Echinoderms, the Arthropods (Crustaceans, Insects, &c.), and the Molluscs (bivalves, snails, cuttle-fish), and finally a great mob of 'worms,' divisible into many classes—Flat-worms, Nemerteans, Round-worms, Chaetopods, &c. have to be distinguished. See VERTEBRATA, and separate articles.

Inverurie, a royal burgh of Aberdeenshire, at the influx of the Urie to the Don, 16 miles NW. of Aberdeen. With Elgin, &c. it returns one member to parliament. Pop. 3165.

Investiture, in feudal and ecclesiastical history, means the act of giving corporal possession of a manor, office, or benefice, accompanied by a certain ceremonial, such as the delivery of a branch, a banner, or an instrument of office, more or less designed to signify the power or authority which it is supposed to convey. The contest about ecclesiastical investitures is interwoven with the whole course of medieval history. The system of feudal tenure had become so universal that it affected even the land held by ecclesiastics. Accordingly, ecclesiastics who, in virtue of the ecclesiastical office which they held,

came into possession of lands began to be regarded as becoming by the very fact feudatory to the suzerain of these lands; and the suzerains thought themselves entitled to claim, in reference to these personages, the same rights which they enjoyed over the other feudatories of their domains. Among these rights was that of granting solemn investiture. Now, in the case of bishops, abbots, and other church dignitaries the form of investiture consisted in the delivery of a pastoral staff or crozier, and the placing a ring upon the finger; and as these badges of office were emblematic—the one of the spiritual care of souls, the other of the espousals, as it were, between the pastor and his church or monastery—the assumption of this right by the lay suzerains became a subject of constant and angry complaint on the part of the church. On the part of the suzerains it was replied that they did not claim to grant by this rite the spiritual powers of the office, their function being solely to grant possession of its temporalities. But the church party urged that the ceremonial in itself involved the granting of spiritual powers; inasmuch that, in order to prevent the clergy from electing to a see when vacant, it was the practice of the emperors to take possession of the crozier and ring, until it should be their own pleasure to grant investiture to their favourites. The disfavour in which the practice had long been held found its most energetic expression in the person of Gregory VII., who having, in the year 1074, enacted most stringent measures for the repression of simony, proceeded, in 1075, to condemn, under excommunication, the practice of investiture, as almost necessarily connected with simony, or leading to it. But a pope of the same century, Urban II., went further, and (1095) absolutely and entirely forbade not alone lay investiture, but the taking of an oath of fealty to a lay suzerain by an ecclesiastic. In the 12th century the pope, Pascal II., agreed to surrender the possessions and royalties of the church on condition of the emperor (Henry V.) giving up his claim to investiture. This treaty, however, never had any practical effect; nor was the contest finally adjusted until the celebrated concordat of Worms in 1122, in which the emperor agreed to give up the form of investiture *with the ring and pastoral staff*, to grant to the clergy the right of free elections, and to restore all the possessions of the Church of Rome which had been seized either by himself or by his father; while the pope, on his part, consented that the elections should be held in the presence of the emperor or his official, but with a right of appeal to the provincial synod; that investiture might be given by the emperor, but *only by the touch of the sceptre*; and that the bishops and other church dignitaries should faithfully discharge all the feudal duties which belonged to their principality. See CHURCH OF ENGLAND, FEUDALISM.

Invincibles. See FENIANS, CAVENDISH.

Involucere. In a shortened Inflorescence (q.v.), such as the umbel, the bracts, unless suppressed, are necessarily close together, and form an apparent whorl (but really a close spiral) around the group of pedicels. This is the involucre. In compound umbels the whorl of bracts of the secondary umbel is therefore a secondary involucre, and is commonly called an involucre. In composites the crowded whorl of green leaves immediately outside the capitulum, which the non-botanist mistakes for a calyx, is constantly termed the involucre, but no less inaccurately, since here the true bracts are those of the separate florets, and occur on the surface of the capitulum itself (e.g. *Finnia*, Sunflower, &c.). The composite 'involucre' is therefore merely derived from those leaves of the axis below the capitulum which remain green and vegetative since bearing

no florets in their axils. In Scabions (q.v.) the true bract of each floret in the capitulum unites as a sheath around the ovary, and is also known as the involucre. Here, again, we have a regrettable use of terms, themselves hardly necessary, in two distinct senses.

Involute. See EVOLUTE.

Involution and Evolution are two operations the converse of each other. The object of the first is to raise a number to any power, which is effected by continuously multiplying the number by itself till the number of factors is equal to the number designating the power. Thus, 2 raised to the third power is $2 \times 2 \times 2$, or 8; 7 raised to the fourth power is $7 \times 7 \times 7 \times 7$, or 2401, &c. Evolution, on the other hand, is the extraction of a root of any number—that is, it is a method for discovering *what* number, when raised to a certain power, will give a certain known number. Thus, the square root of 64 is 8—that is, 8 is the number which, raised to the second power, will give 64; 3 is the fourth root of 81—that is, 3 raised to the fourth power is 81; and so on. The symbols expressive of the two operations are as follow: 5^3 means that 5 is to be raised to the third power; $(7^2)^5$ means that the square or second power of 7 is to be raised to the fifth power; $\sqrt[9]{9}$ or $\sqrt[9]{9}$ signifies that the extraction of the second or square root of 9 is required; $\sqrt[256]{256}$ or $256^{\frac{1}{256}}$, that the fourth root of 256 is to be extracted; and so on. Involution and evolution, like multiplication and division, or differentiation and integration, differ in the extent of their application; the former, or direct operation, can always be completed, while there are numberless cases in which the latter fails to express the result with perfect accuracy.

Io, the daughter of Inachus, king of Argos, was beloved by Zeus, and, transformed through fear of Hera's jealousy into a cow, had many wanderings. See ARGUS.

Iodine (sym. I, equiv. 127) is one of the four non-metallic elements. It was discovered in 1811, by Courtois, in the waste liquors produced in the manufacture of carbonate of soda from the ashes of seaweeds. A few years later Gay-Lussac discovered that it was a simple elementary body. While it is still obtained from the half-fused ash of dried seaweeds, which is known in Britain as Kelp (q.v.), it is much more largely prepared in South America from the iodate of sodium, which is found associated with nitrate of sodium in the native Chili saltpetre.

In small quantity, and usually in combination with sodium, magnesium, or calcium, iodine is very widely diffused over the earth's surface. It exists in sea-water, in marine animals and plants, and in certain mineral springs. It is also found in several minerals, as, for example, in certain Mexican silver ores, in Silesian zinc ores, in phosphorite from the Upper Palatinate, and in coal.

At ordinary temperatures it usually occurs in solid, dark-gray, glistening scales; it is, however, crystallisable, and sometimes appears as an octahedron with a rhombic base. It is soft, and admits readily of trituration, has the high specific gravity of 4.95, and evolves a peculiar and disagreeable odour, which indicates its great volatility. It fuses at 225° (107° C.), and at about 350° (177° C.) it boils, and is converted into the purple vapour to which it owes its name (Gr. *iodēs*, 'violet-like'); it has an acrid taste, and communicates a brownish-yellow colour to the skin. It is very slightly soluble in water, but dissolves readily in watery solutions of iodide of potassium and of hydriodic acid, and in alcohol and ether. Iodine vapour is the heaviest of known vapours, its specific gravity

compared with air as unity being 8.716. It combines directly with phosphorus, sulphur, and the metals. Its behaviour with hydrogen is analogous to that of chlorine and bromine (see HYDROCHLORIC ACID), but its affinities are weaker than those of the last named elements. It likewise combines with numerous organic substances, and the compound which it forms with starch is of such an intense blue colour that a solution of starch forms the best test for the presence of free iodine. By means of this test one part of iodine may be detected when dissolved in one million parts of water.

With hydrogen iodine forms one compound, *hydriodic acid* (HI), a colourless, pungent acid gas, which in most respects is analogous with hydrochloric acid. It may be obtained by gently heating a mixture of amorphous phosphorus, iodine, and water. The soluble iodides of the metals may be obtained by the direct combination of hydriodic acid with the metallic oxides, the resulting compounds being the metallic iodide and water. Some of these iodides are of extreme brilliancy—e.g. the iodide of mercury, scarlet; the iodide of lead, yellow; and others are of great value in medicine. Amongst the latter must be especially mentioned iodide of potassium, iodide of iron, and the iodides of mercury.

Iodide of potassium is one of the most important medicines in the pharmacopœia. It crystallises in colourless cubes, which are sometimes clear, but usually have an opaque whitish appearance, and are soluble in water and spirit. It is decomposed and the iodine set free by chlorine, bromine, fuming nitric acid, and Ozone (q.v.). Iodide of iron is formed by shaking iron wire or filings in a closed vessel with four times the weight of iodine suspended in water. There are two iodides of mercury—viz. the green subiodide (HI₂) and the red iodide (HI₃). There are several well-defined compounds of iodine and oxygen, but they are of no special interest.

The preparations of iodine are employed extensively in medicine and in Photography (q.v.). Iodine itself or its compounds may give rise to the symptoms known as *iodism*; most commonly running at the nose and eyes, with headache and sore throat; sometimes irritation of the intestinal canal, either alone or combined with the other symptoms. In the case of the iodine compounds these unpleasant results usually cease if the dose be increased.

Iodine and its compounds increase the activity of the absorbent system generally, and are useful in enlargement of the glands connected with that system (lymphatic glands, thyroid, spleen), and wherever absorption is deficient (hypertrophy of breasts, uterus, &c.); indolent inflammatory exudation in any organ). But they are perhaps of the greatest value in certain forms of chronic rheumatism, certain stages of syphilis, in serofulous conditions generally, and in chronic poisoning by mercury and lead. In the last case they set free the metals from insoluble compounds in the tissues, and allow them to be eliminated from the body in solution in the urine.

Iodine is chiefly prescribed internally in combination, as iodide of potassium, iodide of iron, especially in strumous cases, and red iodide of mercury in syphilis. Free iodine is very apt to cause irritation of the intestinal canal, and can in general only be employed in small doses. But as an external application, in the form of ointment, tincture, or liniment, it is extensively used and is very valuable. It acts as a para-siticide in ringworm, removes muscular pains, and promotes the absorption of exudations and the subduing of chronic inflammations. In large doses iodine and most of

the iodides act as irritant poisons; but very few fatal cases are on record. In the event of poisoning with the tincture of iodine the first point is to evacuate the stomach. See POISONS.

Iodoform (CHI₃) is a lemon-yellow crystalline substance, having a saffron-like odour and an unpleasant iodine-like taste. Its odour is most persistent, and can hardly be removed. It is of interest as having a composition similar to that of Chloroform (q.v.), from which it only differs in having iodine in the place of chlorine. It may be prepared by the action of iodine on alcohol in the presence of carbonate of potash. It is almost insoluble in water, but dissolves in alcohol, ether, and chloroform. It is readily volatile when heated, and in the form of vapour has anæsthetic properties. It is employed externally as an application to painful ulcers, and it often gives relief in uterine cancer. In the form of iodoform gauze it is used in antiseptic surgery.

Iolite. See CORDIERITE.

Iona, the most famous of the Hebrides, 1½ mile W. of the south-western extremity of Mull. Its modern name is believed to have originated in a mistaken reading of *n* for *u*; the word in the oldest manuscripts being clearly written *Iona*. From the 6th century to the 17th century the island was most generally called *I. Ii, Ia, Ia, Ea, Iy, Ii, Hii, Hii, Hu, Y,* or *Yi*—that is, simply, 'the island'; or *Islandkill, I-Columb-Kille*, or *Hii-Colum-Kille*—that is, 'the island of Columba of the church.' It is 3½ miles long, and 1½ mile broad. Its area, computed by Bede at 'five families' (or 'five hides of land,' as the passage is rendered in the Anglo-Saxon Chronicle), is 3½ sq. m., or 2264 acres, of which rather more than a fourth part is under tillage. The soil is naturally fruitful; its fertility was regarded as miraculous in the dark ages, and, no doubt, led to the early occupation of Iona. Dunii, the highest point of the island, is 327 feet above the sea-level. Pop. 247.

Its history begins in the year 563, when St Columba (q.v.), leaving the shores of Ireland, landed upon Iona with twelve disciples. Having obtained a grant of the island, he built upon it a monastery, which was long regarded as the mother-church of the Picts, and was venerated not only among the Scots of Britain and Ireland, but among the Angles of the north of England, who owed their conversion to the self-denying missionaries of Iona. From the end of the 6th to the end of the 8th century Iona was scarcely second to any monastery in the British Isles; and it was this brilliant era of its annals which rose in Johnson's mind when he described it as 'that illustrious island which was once the luminary of the Caledonian regions, whence savage clans and roving barbarians derived the benefits of knowledge and the blessings of religion.' But neither piety nor learning availed to save it from the ravages of the fierce and heathen Norsemen. They burned it in 795 and again in 802. Its 'family' (as the monks were called) of sixty-eight persons were martyred in 806. A second martyrdom, in 825, is the subject of a contemporary Latin poem by Walafrius Strabus. On the Christmas evening of 986 the island was again wasted by the Norsemen, who slew the abbot and fifteen of his monks. Towards the end of the next century the monastery was repaired by St Margaret, the queen of Malcolm Canmore. It was visited in 1097 by King Magnus Barefoot of Norway. It was now part of that kingdom, and so fell under the ecclesiastical jurisdiction of the Bishop of Man and the Archbishop of Trondheim. In 1203 a Benedictine monastery was founded here, and a Benedictine (afterwards Augustinian) nunnery.

In 1506 Iona became the seat of the Scottish Bishop of the Isles, the abbey church being his cathedral, and the monks his chapter.

No building now remains on the island which can claim to have sheltered St. Columba or his disciples. The most ancient ruins are the Laith-ricehan, or Foundations, in a little bay to the west of Port a-Churraich; the Cobhan Cuillich, or Culdees' Cell, in a hollow between Dumii and Dumbuirg; the rath or hill-fort of Dumbuirg; and the Gleann-an-Teampull, or Glen of the Church, in the middle of the island. St. Oran's Chapel, now the oldest church in the island, may probably be of the later part of the 11th century. St. Mary's Nunnery is perhaps a century later. The Cathedral, or St. Mary's Church (c. 1203), whose min and precincts were made over by the late Duke of Argyll in September 1899, has a choir, with a north sacristy and south chapels; north and south transepts; a central tower, 70 feet high; and a nave. An inscription (defaced about 1849) on one of the columns of the choir seemed to denote that it was the work of an Irish ecclesiastic who died in 1203. On the north of the cathedral are the chapter-house and other remains of the conventual or monastic buildings. In the 'Reilig Oran'—so called, it is supposed, from St. Oran, a kinsman of St. Columba, the first who found a grave in it—were buried Egfrid, king of Northumbria, in 684; Godfred, king of the Isles, in 1188; and Haec Ospac, king of the Isles, in 1228. No monuments of these princes now remain. The oldest of the many tombstones on the island are two with Irish inscriptions, one of them, it is believed, being the monument of a bishop of Connor who died at Iona in 1174. To this interesting island a great Catholic pilgrimage took place in June 1888. For St. Martin's Cross, see Cross; see also the Duke of Argyll's *Iona* (1871; new ed. 1889), and other works cited at COLUMBA.

Ionia, the ancient name of the coast districts and islands of western Asia Minor. The name was derived from the Ionians, one of the four most ancient tribes in Greece. According to the usually received tradition, after being driven out of the Peloponnese, they removed to Attica, whence, about 1060 B.C., they sent forth warrior bands to settle on the bays and promontories and islands of Asia Minor; but it is more probable that the immigration was gradual and was spread over a long period of time. Although mountains, Ionia embraced the three valleys watered by the Hermus, Cayster, and Meander, and was a beautiful and fertile country, extending, according to Ptolemy, from the river Hermus to the river Meander, though Herodotus and Strabo make it somewhat larger. It soon reached a high point of prosperity; agriculture and commerce flourished; colonies were sent out, which settled on the shores of the Black Sea and in the south of Gaul (Masilias); and great cities arose, of which Ephesus, Smyrna, Clazomenae, Erythrae, Colophon, and Miletus were the most celebrated. These cities, with six others, formed the Ionian League. Each retained its independence, the form of government being democratical; but all met together periodically at Panionium, near Priene, for the discussion of such affairs and interests as they had in common, for religious worship, and for the celebration of athletic games. A few centuries later the twelve cities were made thirteen by the accession of Smyrna. These Ionian states were gradually subdued by the kings of Lydia. Then they passed (557 B.C.) under the sway of the Persians, but were allowed a considerable measure of internal liberty. They revolted, however, in 500, but were reduced to subjection after a bloody battle near Ephesus in 496 B.C. During the great Persian war the contingent which they furnished to their oriental

masters deserted to the Greeks at the battle of Mycale (479 B.C.); thereupon the Ionians entered into an alliance with Athens, upon which they now became dependent. By the peace of Antalcidas (387 B.C.) they were again made subject to the Persians, and remained so till the time of Alexander the Great. From this period Ionia shared the fate of the neighbouring countries, and in 64 B.C. was added to the Roman empire by Pompey, after the third Mithridatic war. In later times it was so ravaged by the Turks that few traces of its former greatness are now left.—The Ionians were regarded as somewhat effeminate. They were wealthy and luxurious; and the fine arts were cultivated amongst them at a much earlier date than amongst their kinsmen in the mother-country. Two of the celebrated temples of the Greek world, that of Diana and that of Apollo, both near Ephesus, were in Ionia. For Ionic architecture, see GREEK ARCHITECTURE. For the Ionian mode, see MUSIC. The Ionian School was the name given to the representative philosophers of the Ionian Greeks, such as Thales, Anaximander, Anaximenes, Heraclitus, Anaxagoras (see these names), who devoted themselves mainly to the question what was the primordial constitutive principle of the cosmical universe. The Ionic dialect, nearly akin to Attic, exceeds the other Greek dialects in softness and smoothness, chiefly from the greater richness of its vowel-system.

Ionian Islands, a group, or rather chain, of islands, about forty in number, stretching along the west and south coasts of Greece. Corfu (Corcyra), Paxo, Santa Maura, Ithaca (Theaki), Cephalonia, Zante, and Cerigo (Cythra) are the largest. Accounts of their physical features and other particulars will be found under the separate islands. Total area, 1010 sq. m.; pop. (1879) 244,133. (1889) 238,783, the great majority of Greek descent. The surface is generally mountainous, the plains and valleys being fertile. The collective term 'Ionian' is of modern date. Previous to the subjugation of Greece by Rome the only one of these islands that rose above the historic horizon was the Corinthian colony of Corcyra. On the division of the Roman empire these islands were included in the eastern half. In 1081 Corfu and Cephalonia fell into the hands of Robert Guiscard, and from that time they had a very chequered history for three hundred and twenty years. In 1491 Corfu came into the possession of the Venetians, who in the same century acquired Zante and Cephalonia, and subsequently most of the other islands included in the group. The Venetians retained them until 1797, when they ceded them to France. The islands were seized by Russia and Turkey in 1799; and the Emperor Paul created the Republic of the Seven United Islands, under the protection of Turkey. But in 1807 they were given back to France by the treaty of Tilsit. In 1809 Great Britain seized Zante, Cephalonia, and Cerigo, in 1810 Santa Maura, in 1814 Paxo, and after Napoleon's fall Corfu; and on November 5, 1815, were formed the United States of the Ionian Islands, under the protectorate of Great Britain. While they were connected with England the government was carried on by two assemblies and the Lord High Commissioner, the representative of the British government. The rule of the successive commissioners, although directed to the construction of roads, the regulation of the systems of taxation, the establishment of educational institutions, the reform of the administration of justice, and similar public works for the furtherance of the intellectual and material welfare of the people, was on the whole arbitrary and despotic. There was permanent friction, often of a severe character, between the representative of Britain and the representatives of the islanders.

Nor did the concessions of freedom of the press, an extension of the franchise, and freedom of election (with the right of the ballot), both municipal and parliamentary, extorted in 1849 by the disturbances of Europe during the year previous, do much to reduce the friction. Insurrections broke out amongst the peasantry; the discontent with British rule increased; and the party that agitated for incorporation with Greece waxed daily stronger. In the end of 1858 Mr Gladstone was sent as a special commissioner to ascertain what could be done to meet the claims of the population. He declared against annexation to Greece. But in 1863 the election of the son of the king of Denmark as constitutional king of Greece gave England an opportunity of getting rid of this troublesome dependency. On 14th November a treaty was concluded at London by which the islands were incorporated in Greece. In February 1867 they were visited by a series of earthquake shocks, most violent in Cephalonia, where they caused great destruction of life and property, and almost destroyed the two chief towns. The islands have now no geographical unity. Cythera (Cerigo) is included in the nomarchy of Argolis. The rest are distributed among the three nomarchies of Coreyra (Corin), Cephalonia, and Zacynthos (Zante). See works by Ansted (1863), Kirkwall (1864), Von Warsberg (Vienna, 1878-79), and Riemann (Paris, 1879).

Ions, the components into which an electrolyte is broken up on electrolysis. The one, the Anion (the electro-negative component—e.g. chlorine), travels 'against' the current (in its conventional direction in the circuit), and is deposited on or chemically attacks the anode or positive electrode; the other, the Cation (the electro-positive component—e.g. copper), travels 'with' the current to the cathode—e.g. to the spoons in the plating bath. See ELECTRICITY, Vol. IV. p. 270.

Iota. See I.

I O U, a memorandum of debt given by a borrower to a lender, so called from being made in this abbreviated form:

LONDON, 1st January 1880,

I O U Twenty Pounds.

To Mr C. D.

A. B.

It is a convenient document, because it requires no stamp, and yet it is valuable evidence of the existence of the debt, in case an action is afterwards brought. If, however, the I O U contain any promise to pay the debt, then it will amount to a promissory-note, and be void unless it have a stamp. It should be holograph, dated, and addressed to some person or persons, but it does not prove its own date.

Iowa, one of the United States of America, extends from 40° 36' to 43° 30' N. lat., and from 90° 15' to 96° 38' W. long., and has an area of 55,175 sq. m. It is bounded on the N. by Minnesota, on the E. by the Mississippi River, on the S. by the state of Missouri, and on the W. by the Missouri and Big Sioux rivers. The climate is continental, with cold winters, hot summers, and sudden changes of temperature. The autumns are beautiful and of long duration. The mean temperature of the year is 47°, and the annual rainfall about 33 inches. Iowa is noted for its healthfulness, the annual death rate being only 119 in every 10,000 of population. The surface is a rolling prairie; there are no mountains, and hills or bluffs can only be found along the principal streams. The average elevation is not far from 900 feet. The highest point (1694 feet) is about 70 miles E. of the north-west

corner of the state, and the lowest (444 feet) at the confluence of the Des Moines River with the Mississippi. The soil is unsurpassed in richness and productiveness, all the land being tillable except a few rocky bluffs near the large rivers. Natural forests cover the slopes that intervene between the rivers and the high lands, and since the cessation of the destructive prairie-fires the area of woodland has been steadily increasing. Iowa has also extensive and valuable mineral deposits, as coal, lead, gypsum, limestone, clay, and mineral paints. The coal, which is bituminous and of good quality, extends over an area of nearly 20,000 sq. m., and above 4 million tons have been raised annually of late years. The Mississippi on the eastern, and the Missouri on the western border are navigable. To both of these are tributary a number of inland rivers, those of the Mississippi system flowing in a south-easterly, and those of the Missouri system in a south-westerly direction. The Upper Iowa, Turkey, Maquoketa, Wapsipinicon, Iowa (with its large affluent the Cedar), Skunk, and Des Moines rivers are the principal tributaries of the Mississippi. The rivers of the Missouri system are the Big Sioux, Rock, Floyd's, Little Sioux, Boyer, and Nishnabotony. There are also several small lakes in the northern portion of the state, situated principally near the great water-sheds.

Iowa is pre-eminently an agricultural state. The nature of the surface offers excellent facilities for the use of agricultural machinery, and makes farming attractive and profitable. Nearly two-thirds of the 34 million acres of tillable land are now under cultivation, producing annually 300 million bushels of maize, 30 million bushels of wheat, 60 million bushels of oats, 4 million bushels of barley, 2½ million bushels of flax, 1½ million bushels of buck-wheat, half a million bushels of rye, 6 million tons of hay, 2 million gallons of sorghum-syrup, 10 million bushels of potatoes, 100 million pounds of butter, 5 million pounds of cheese, 2 million pounds of wool, and 32 million dozen eggs. The number of live-stock at the census of 1890 were as follows: horses, 1,312,079; cattle, 4,000,000; mules, 41,648; swine, 7,000,000; sheep, 450,000. The total annual value of all agricultural products may be fairly estimated at 300 million dollars. While Iowa has good water-power, cheap fuel, and excellent transportation facilities, the development of its manufacturing interests has been but slow. In 1880 the number of manufacturing establishments was 6921; the number of persons employed in them, 28,372; and the value of their annual products, \$71,045,926. In 1890 there were 7440 factories, with 59,174 workers, producing goods of the value that year of \$125,049,200. Among the leading articles of manufacture are flouring and grist-mill products, packed meats and canned goods, sawed lumber, carriages and wagons, saddlery, agricultural implements, furniture, bricks and tiles, foundry products, woollen goods, and clothing. The commerce is chiefly domestic. The principal exports are agricultural and dairy products, coal, gypsum, and lead; the imports, groceries and manufactured goods.

The legislative authority is vested in the general assembly, consisting of two houses, the senate (50 members) and house of representatives (100), and meeting in regular session in January of each even-numbered year. The supreme executive power is vested in a governor, who is elected for a term of two years. The supreme court consists of five judges, elected for a term of six years. The state is divided into ninety-nine counties, and is represented in the national congress by two senators and eleven representatives. The educational policy of the state is most liberal. Schools are established

in every district, and must be kept in operation at least six months each year. The school system embraces the district and high school, the state university, state normal school, and state agricultural and industrial college. In 1890 there were 26,769 teachers in about 17,000 common schools, which were attended by 503,755 pupils. Upwards of twenty high schools (including the state university, Drake University in Des Moines, and Cornell College) have nearly 400 teachers and over 7,000 pupils. Iowa has the lowest percentage of illiteracy of any state in the Union. Of 324,096 inhabitants born abroad, 127,246 were German born (1890). The value of property is estimated at 2,000 million dollars.

The territory of the state of Iowa formed part of the 'Louisiana Purchase.' After Iowa had successively been under the jurisdiction of the territorial governments of Missouri, Michigan, and Wisconsin, it was organized as a separate territory on the 4th of July 1838, with Burlington as its capital. It had then sixteen counties and a population of 22,860. The following year the general assembly located the seat of government at Iowa City. On 28th December 1846 the state was admitted into the Union, with a population of nearly 100,000. In 1856 Des Moines became the permanent capital. Iowa's population in 1850 was 192,214; in 1860, 674,913; in 1870, 1,194,020; in 1880, 1,624,615; and in 1890 it was 1,911,896; and Iowa was the tenth state in the Union in respect of population. In 1890 there was within the limits of the state one city (Des Moines) of over 50,000 inhabitants; five between 20,000 and 40,000 (Sioux City, Dubuque, Davenport, Burlington, Council Bluffs); five between 10,000 and 11,000; and twelve between 4,000 and 10,000.

Iowa City, capital of Johnson county, Iowa, and the seat of the territorial and state government from 1839 to 1836, is situated on the Iowa River, 120 miles by rail E. of Des Moines. The old capitol is now the home of the state university. The town has a foundry and a number of mills and factories. Pop. (1880) 7123; (1890) 7106.

Ipecacuanha, the name both of a very valuable medicine and of the plant producing it. The plant (*Cephaelis Ipecacuanha*) belongs to the natural order Cinchonaceae, and is a native of the damp shady woods in Brazil and some other parts



Ipecacuanha (Cephaelis Ipecacuanha) in flower:
a, the root.

of South America. More recently it has been cultivated in India and Ceylon, although there is a tendency under cultivation for the plant to run into varieties. It is somewhat shrubby, with a few oblong lanceolate leaves near the ends of the branches, long-stalked heads of small white flowers, and soft dark purple berries. The part of ipecacuanha used in medicine is the root, which is simple or divided into a few branches, flexuous, about

as thick as a goose-quill, and is composed of rings of various size, somewhat fleshy when fresh, and appearing as if closely strung on a central woody cord. Ipecacuanha root is prepared for the market by mere drying. It is collected at all seasons, although chiefly from January to March. The plant is never cultivated in Brazil. It has now become scarce in the neighbourhood of towns, but, owing to the readiness with which it is propagated from portions of the root, it is not likely to be exterminated.

It is in the bark of the root that the active principle, the *emetic*, almost entirely lies; the other ingredients, such as fatty matters, starch, lignine, &c., being almost inert. Emetine is represented by the formula $C_{28}H_{40}N_2O_{15}$. It is a white, inodorous, and bitter powder, moderately soluble in alcohol, and having all the characters of the vegetable alkaloids. It acts as a violent emetic in doses of $\frac{1}{16}$ th of a grain or less, and is a powerful poison. In good specimens of root it is present to the extent of nearly 1 per cent. In small and repeated doses—as, for instance, of a grain or less—ipecacuanha increases the activity of the secreting organs, especially of the bronchial mucous membrane, and of the skin. In larger doses of from 1 to 5 grains it excites nausea and depression; while in doses of from 15 to 30 grains it acts as an emetic, without producing such violent action or so much nausea and depression as tartar emetic. Ipecacuanha is useful as an emetic when it is necessary to unload the stomach in cases where there is great debility, or in childhood. As a nauseant, expectorant, and diaphoretic it is prescribed in affections of the respiratory organs, as catarrh, hooping-cough, asthma, &c.; in affections of the alimentary canal, as indigestion and dysentery; and in disorders in which it is desired to increase the action of the skin, as in diabetes and in febrile affections.

Besides the Powder, the most useful preparations are the Wine of Ipecacuanha—of which the dose to an adult as a diaphoretic and expectorant ranges from 10 to 40 minims, and as an emetic from 2 to 4 drachms—and the Compound Ipecacuanha Powder, commonly known as *Dover's Powder* (q.v.). To produce the full effect as a sudorific a dose of 10 grains of Dover's Powder should be followed by copious draughts of white-wine whey, treacle-posset, or some other warm and harmless drink.

Iphigenia, in Greek legend, a daughter of Agamemnon and Clytemnestra, or, according to others, an adopted daughter of Clytemnestra. Her father, having offended Artemis, could only avert the wrath of the goddess by promising to sacrifice to her the most beautiful thing born within the year. This happened to be Iphigenia. When Iphigenia was brought to the altar, however, she disappeared, and a hind lay there in her stead; Artemis herself carried her off in a cloud to Tauris (Crimea), where she became her priestess, but was afterwards recognised by her brother Orestes, who took her, along with the image of Artemis, to Attica. The legend is of post-Homeric origin, but evidently goes back to the barbaric stage of the Greek religion, when human sacrifices were wont to be made on solemn occasions. It gave a subject to painters, sculptors, and poets, and is imperishably enshrined in two splendid tragedies of Euripides. In modern art it has employed the genius of Gluck in music, and of Racine and Goethe in poetry.

Ipomoea, a genus of plants of the natural order Convolvulaceae, differing very little from the genus *Convolvulus* (q.v.).

Ipsambul. See *ARU SIMBEL*.

Ipsus. See *ANTIGONUS*.

Ipswich, the county town of Suffolk, 69 miles N.E. of London by rail, is situated on the side of a hill on the left bank of the river Gipping, which, here taking the name of the Orwell, becomes tidal, and after a south-easterly course of 12 miles more falls into the German Ocean at Harwich. In the older portions of the town, principally grouped near the river, the streets are narrow and irregularly built, and still retain many picturesque old buildings, decorated with carved work, such as Sparrowe's House (1567), the Neptune Inn (1639), Archdeacon's Place (1471), and Wolsey's Gateway (1528). Of public buildings the principal are a town-hall (1868), in the Italian Renaissance style of architecture, surmounted by a clock-tower 130 feet high; post-office (1881), and corn exchange (1882), both close by, and in the same style; public hall (1868); museum, schools of science and art, and free library (1881-87), the first of which, founded in 1847, is notable for its splendid collections of Suffolk Crag fossils and British birds; custom-house (1845); mechanics' institute (1824); hospital (1835-69-77); barracks; and a theatre (1891), on the boards of whose predecessor Garrick, Mrs Keeley, and Mr Toole made their debut. The churches are sixteen in number, mostly built of flint, and in the Perpendicular style, having as the principal or "metropolitan" church St Mary Le Tower, with a tower and spire 176 feet high, and a fine peal of twelve bells. Of educational establishments the principal is the grammar-school, dating from at least 1477, reorganised by Queen Elizabeth in 1565, moved into new buildings, of which the foundation-stone was laid by the Prince Consort, in 1851, and reconstituted under a new scheme in 1881; it has an income from endowment of £500, and eight scholarships of an aggregate annual value of £233. Near it are two arboretums, charmingly laid out, and Christchurch Park, with its fine Tudor mansion (1549). Another favourite resort is the promenade by the river-side, skirting the west side of the dock. This latter, opened in 1842, covers 30 acres, and is approached from the Orwell by an entrance lock (1881) capable of admitting vessels of 1400 tons. The principal manufactures are those of agricultural implements, railway plant, artificial manures, and clothing. In the history of Ipswich the chief events deserving mention are its pillaging in 991 and 1060 by the Danes; the granting in 1199 of its first charter by King John; the appointment of its first and only suffragan bishop (1525); visitations of the plague (1603 and 1666); partial destruction by fire (1654); and visits of Elizabeth (1561 and 1565), George II. (1736), and George IV., when Regent, Cardinal Wolsey, Dr William Butler (physician to James I.), Bishops Brownrigg and Lany, Clara Reeve, and Mrs Sarah Trimmer were natives, and Gainsborough the painter a resident for fifteen years. Ipswich has returned two members to parliament since 1447; and its population, in 1801 only 11,336, had risen in 1841 to 25,264, in 1881 to 50,546, and in 1891 to 57,360. See works by Clarke (1830), Woldenspoon (1842-50), Glyde (1850-87), and Dr J. E. Taylor (1889).

Ipswich, a town of Queensland, on the river Bremer, 23 miles W. of Brisbane by rail. It stands in a rich coal-mining district. Pop. with suburbs (1891) 10,190.

Iquique, the port and capital of the Chilean territory of Tarapacá (Peruvian till 1881). It has amalgamating works in connection with neighbouring silver mines, a foundry, and exports saltpetre, borax, and iodine. The climate is hot, and drinking-water has to be obtained by distillation. Earthquakes have more than once damaged the town. The roadstead is safe, and a mole has been built. Pop. (1876) 11,717; (1895) 33,931.

Iquitos, a town in the Peruvian department of Loreto, on the left bank of the Marañón, about 75 miles above the mouth of the Rio Napo. It has an active trade, valued at two million dollars annually; the imports are exchanged mostly for india-rubber. Pop. 8000—five-sixths Indians and half-castes.

Irak-Ajemi (Persian Irak), a central province of Persia, nearly coincident with ancient Media. A great portion of the surface consists of elevated tablelands, but there are also numerous fertile valleys only partly cultivated. The eastern parts are occupied by the extensive salt desert of Dasht-i-Kavir. The province contains the principal towns of the kingdom, including Teheran, the capital, and Isfahan. The industries are confined to the weaving of cloth and carpets, and the making of glass and porcelain. Area, 138,190 sq. m.; pop. estimated at a million.

Irak-Arabi (Arabian Irak), the most south-easterly district of Turkey in Asia, almost continuous with ancient Babylonia (q.v.), lies between the lower courses of the Tigris and the Euphrates, and includes the lands adjacent thereto. The region comprises the ruins of the ancient cities of Babylon, Seleucia, and Ctesiphon, and the modern towns of Bagdad, Basra, and Meshed Ali. The population is estimated to number nearly 2,000,000, chiefly nomads. Since 1867 cholera has been almost constantly prevalent.

Iran, or ERAN, originally the name applied to the great Asian plateau which has for its borders on the north the Hindu Kush and the Elburz, on the east the Indus, on the south the Persian Gulf, and on the west Kurdistan and the Tigris. The term is now the official designation of the kingdom of Persia. In early times the inhabitants of the Iranian plateau, together with the peoples of the adjoining parts of India, bore the common appellation of Aryans. See ARYAN RACE.

Irawadi, or IRRAWADDY, the principal river of Burma. Its sources are not known with certainty. A favourite origin for it with some authorities was the Sampo (q.v.), the great river of Tibet. But this has been shown in 1878-82 to be the upper waters of the Brahmaputra. In 25° 50' N. lat., a short distance above Bhamo, two arms, the Mali-kha and the Meh-kha, unite to form the river that is undoubtedly the Irawadi of Burma. Those two arms are believed to have their sources in the Namkin or Khanung range, that walls in the Zayul basin on the south; they certainly come from that direction. But General Walker, late of the Indian Trigonometrical Survey, is responsible for the hypothesis, advanced in 1887, that the right-hand or eastern branch, the Meh-kha, is the southward continuation of the Lu-Kiang, which has hitherto been regarded as the upper part of the Salwin; and he also identifies the Lu-Kiang with the Giama-nu-chu or Nu River, which rises in the north of Tibet and has a course, south-easterly, of some 700 miles in that country. From Bhamo the Irawadi has a very sinuous channel, its predominant direction being, however, south. Over this entire stretch (about 700 miles) it is navigable for small boats, in spite of numerous islands and sandbanks that litter and impede its channel, and in spite of two rock-bound defiles through which it passes between Bhamo and Mandalay. A third defile occurs nearly 100 miles above Bhamo. Its waters are muddy and its current generally rapid. Before reaching the sea, in nearly a dozen mouths, in the west of the Bay of Martaban, the river spreads out in a wide delta, 18,000 sq. m. in extent. Of its mouths two only are used by sea-going vessels, the Bassien on the west and the Rangoon on the east. The valley and plain of the Irawadi are very fertile, and grow vast quantities

of rice. The river is the chief artery of the country; on its banks stand the principal towns, Bassain, Rangoon, Prome, Ava, Mandalay, Blanno; its banks were the home of Burmese civilisation; its waters have served as the main means of communication not only to the interior of Burma, but to the south-western provinces of China and of Tibet. The river drains an area of at least 158,000 sq. m. Its largest affluent, coming from the right hand, is the Chindwin. This and the two left-hand tributaries, the Shweli and Myitnge, are alone navigable. The plain for 150 miles from the sea, being liable to annual inundations, has been protected by embankments built along each side of the river since 1863. The carriage of goods and merchandise is shared between the steamers of the English 'Hawala Flotilla Company' and a numerous fleet of native boats. For the question of origin, see General Walker's papers in *Proc. Roy. Geog. Soc.* (1887 and 1888).

Irbit, a town of the Russian government of Perm, 1170 miles nearly due E. of St Petersburg. Its celebrated fair, held in February, is, next to that of Nijni Novgorod, the most important in the empire. Pop. 4242.

Ireland, an island forming part of the United Kingdom of Great Britain and Ireland, lies between 51° 26' and 55° 21' N. lat., and 5° 20' and 10° 26' W. long. It is washed on the N., W., and S. by the Atlantic, and on the E. by the North Channel (13 miles wide), the Irish Sea (138 miles), and St George's Channel (47 to 69 miles), which separate it from the larger island of Great Britain. It is an irregular rhomboid in shape, its greatest length, from Fair Head in Antrim to Crow Head in Kerry, being 302 miles; its greatest meridional length is 225 miles, and the average breadth 110 miles. The island was known to the Greek geographers as *Ierna* (Strabo), and to the Latins as *Hibernia* and *Juverna*. From the latest of the prehistoric occupants of 'The Green Island,' the invading Milesians or Scots, came the Latinised *Scotia*, one of the names by which the 'Isle of Saints' was known from the 6th till the 13th century.

Area.—Ireland is divided into the four provinces of Ulster, Leinster, Munster, and Connaught, which again are subdivided into thirty-two counties. The total area is 20,819,928 acres, or 32,531 sq. m., or nearly two thirds of that of England without Wales. Of the total area 15,066,761 acres were in 1889 arable and grass land, 326,343 acres were covered with wood, and 1,935,649 acres were bog, waste, roads, &c.

Population.—In 1801 the population of Ireland was 5,395,156 (a density of 166 per sq. mile); in 1841 this had increased to 8,175,124 (251 per sq. mile); thereafter set in, owing to emigration, a steady decrease, so that in 1891 the population was only 4,704,750 (144 per sq. mile). In 1891, 936,759 belonged to the agricultural class, 656,410 to the industrial, 255,114 to the domestic, 214,343 to the professional, and 83,173 to the commercial. In 1881 Ireland had only six towns with populations exceeding 20,000, and in 1891, eight; of which Dublin had 361,891, and Belfast 255,950. In 1890, 57,484 persons, and in 1891, 58,436 persons emigrated from Ireland, the vast majority of them going to the United States. By far the greatest number who left Ireland in one year emigrated in 1883—108,724. According to Mr Parnell, in 1890 there were in England and Scotland 750,000 persons of Irish birth (with probably 1,500,000 descendants). At the census of 1890 there were in the United States 1,854,971 persons of Irish birth; between the years 1821 and 1889, 3,413,152 Irish persons settled in the States. In 1881 there were in Canada

957,403 persons 'of Irish origin' (more than those of English origin, nearly twice as many as those of Scottish origin). In Victoria there were in 1881, 86,750 Irish; in Queensland, 21,300; in Western Australia, about 3000; in New Zealand, 50,000. In the other Australian colonies, South Africa, &c., the census does not distinguish precisely between the various British elements of population. During the thirty-seven years 1853-89, 2,775,007 Irish emigrated; 2,289,735 to the United States, 173,343 to Canada, and 289,733 to Australia. In 1851-99 the total was 3,796,131.

Provinces and Counties.	Area in Stat. Acres.	Pop. 1841 *	Pop. 1881 *	Pop. 1891 *
LEINSTER.				
Carlow	221,344	86,228	46,568	40,936
Dublin	226,895	372,773	418,910	419,216
Kildare	418,496	111,488	75,804	70,706
Kilkenny	599,732	202,429	99,531	87,261
King's	493,985	146,857	72,852	65,563
Lancaster	293,409	115,491	61,009	52,647
Louth	292,123	128,240	77,684	71,038
Meath	579,861	183,828	87,469	76,987
Queen's	424,834	133,930	73,124	64,883
Westmeath	453,433	141,309	71,798	65,109
Wexford	576,788	202,633	123,854	111,778
Wicklow	509,175	126,143	70,386	62,136
Total	4,876,618	1,973,731	1,278,989	1,187,760
MUNSTER.				
Clare	827,994	286,304	141,467	124,483
Cork	1,849,686	834,118	493,667	458,432
Kerry	1,188,948	263,880	201,639	179,156
Limerick	680,842	330,029	180,632	158,942
Tipperary	1,061,734	436,553	199,612	173,188
Waterford	464,552	196,187	112,768	98,251
Total	6,967,723	2,396,464	1,331,115	1,172,402
ULSTER.				
Antrim	762,080	360,575	421,943	471,179
Armagh	378,066	252,230	163,177	143,289
Cavan	457,599	213,158	129,475	111,917
Donegal	1,197,154	296,438	206,635	185,635
Down	612,399	361,146	272,107	224,668
Fermanagh	457,599	156,181	84,879	74,170
Londonderry	522,415	222,174	164,991	152,669
Monaghan	319,741	209,442	102,718	86,206
Tyrone	806,678	312,956	197,749	171,491
Total	5,483,291	2,386,373	1,743,975	1,639,814
CONNAUGHT.				
Galway	1,569,565	440,198	242,066	214,732
Letchmery	392,363	155,297	90,772	78,938
Mayo	1,360,731	388,887	245,212	219,034
Roscommon	667,694	253,594	139,190	114,397
Sligo	464,796	189,886	111,578	98,013
Total	4,392,086	1,418,862	814,667	724,774
General Total	20,819,928	8,175,124	5,171,836	4,704,750

* The figures for 1881 and 1891 include the soldiers and sailors serving in Ireland; the figures for 1841 exclude them.

Coasts and Physical Aspects. The eastern coast is comparatively uniform and even; but the coasts on the north, west, and south are in many places rocky and high, and indented with numerous deep bays, especially at the south-west corner of the island. Most of these bays afford excellent harbours, some even for the largest of modern warships. On the west may be named the Bays of Donegal, Sligo, Clew, Galway, the estuary of the Shannon, and Dingle, Kenmare, and Bantry bays; on the south the spacious harbours of Cork and Waterford; on the north Loughs Foyle and Swilly, which both penetrate a long distance inland. On the east side, opposite England, are Wexford Haven, the Bays of Dublin, Drogheda, and Dundalk, and Carlingford and Belfast loughs. Numerous islands occur, especially on the west, but they are for the most part small in size. Valentia, in the extreme south-west, was the terminus on the British side of the first Atlantic cables to North America, as those of 1858, 1865, and 1866, and of others since

IRELAND

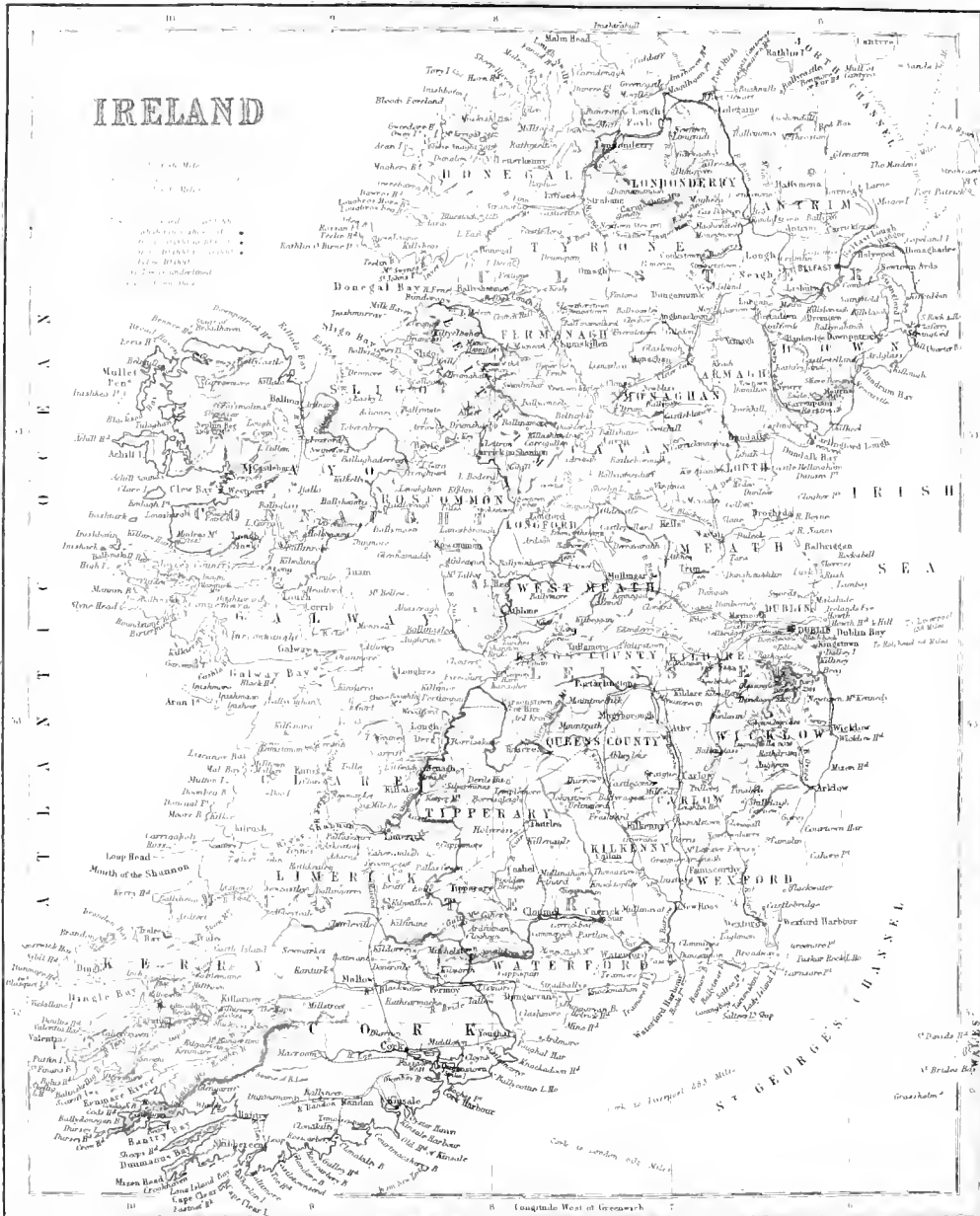

then. On the west too are the islands of Aran, Achill, the Inishkeas, &c. Off County Antrim, in the north-east, are Rathlin Island and the Giants' Causeway (q.v.). Dangerous points on the coasts, and some low groups of rocks, are protected by fifty-seven lighthouses and three floating lights.

The surface is, generally speaking, an undulating plain, relieved, more particularly towards the coasts, by detached groups of low hills. The principal ranges are the Mourne Mountains in Down, which attain their highest elevation in Slieve-Donard (2796 feet); the mountains of Wicklow, which rise in Lugnaquilla to a maximum height of 3039 feet; and Macgillivuddy's Reeks, in Kerry, their highest peak, Carran-Tuail (3414 feet), being the loftiest in all Ireland. The central parts of the island are quite flat, and consist very largely of bogs or morasses, which occupy altogether 1,772,450 acres, or nearly one-ninth of the entire area. The largest is the Bog of Allen, which stretches over a large portion of Kildare, Carlow, King's, and Queen's counties. These bogs have an average depth of 16 to 25 feet, but occasionally go down to 47 feet; they yield large quantities of peat or turf, and contain numerous remains of skeletons of men and animals, and relics of human habitation and occupancy. Extensive tracts of deep wet bog occur in Longford, Roscommon, and other counties, and give a peculiarly dreary and desolate aspect to the scenery. Notwithstanding the quantity of water in these bogs, they exhale no miasma injurious to health, owing to the large quantity of tannin which they contain.

Hydrography.—The principal river of Ireland, and the largest in the United Kingdom, is the Shannon (q.v.). The streams which drain the eastern part of the central plain are the Liffey and Boyne; the south-eastern part, the Suir, Barrow, and Nore; while the waters of the north-eastern part are collected into Lough Neagh, chiefly by the Blackwater, and are thence discharged into the sea by the Lower Bann and Newry Canal. The rivers external to the great central plain are necessarily short. The principal are the Erne, flowing to the north-west; the Foyle and Bann, to the north; the Lagan, to the north-east; the Slaney, to the south-east; and the Bandon, Lee, and Blackwater, to the east, through the county of Cork. None of these rivers are of much importance to navigation beyond their estuaries, though small boats can ascend some distance up the larger streams by the aid of canals, locks, &c. Artificial rivers or canals connect some of the more important trading centres; for instance, Dublin has water-communication with the Shannon by means of the Grand (165 miles) and Royal (76) canals, and Lough Neagh with the same river by the Ulster Canal and river Blackwater.

The lakes of Ireland (called loughs) are both numerous and extensive in proportion to the size of the island. The largest is Lough Neagh in Ulster, covering an area of nearly 100,000 acres. The other loughs of consequence are Erne and Derg, also in Ulster; Conn, Mask, and Corrib, in Connaught; Allen, Ree, and Derg, expansions of the river Shannon; and the lakes of Killarney (q.v.) in Munster. The name lough is also applied to many salt-water inlets (see above).

Geology. The configuration or relief of Ireland is, as a matter of course, intimately related to the geological structure of the island. The mountains are built up of relatively hard crystalline schists and disturbed Lower Palaeozoic rocks, while the low grounds are nearly co-extensive with less indurated and comparatively undisturbed Upper Palaeozoic strata. The interior and larger portion of the

island is in fact a great undulating plain, the central area of which, between Dundalk Bay or Dublin Bay in the east and Galway Bay in the west, does not exceed a height of 250 feet above the level of the sea. The strata throughout this central plain belong almost exclusively to the Carboniferous system. Here and there the ground rises to heights ranging between 1000 and 3000 feet so as to form more or less isolated hills and groups of hills and mountains as Slieve Bloom, the Silvermine Mountains, Slieve Bernagh, Galtymore, &c. These are simply islets of older Palaeozoic rocks that peer above the general level of the great Carboniferous plain. The chief highlands of the island are met with in the maritime regions. Thus we have in the north the highlands of Donegal and Derry, the plateau-basalts of Antrim, and the Mourne and Carlingford Mountains with Slieve Gallion; in the south the highlands of Kerry and Cork, with Knockmealdown, &c.; in the west those of Mayo, Galway, and Connemara; and in the east the mountains of Wicklow.

Ireland is thus built up chiefly of Palaeozoic rocks—strata of Mesozoic and Cainozoic age being very meagrely developed. *Archaean* gneissose and schistose rocks occur chiefly in the north-west and west—the coarse granitic gneiss of Donegal being regarded as belonging to the same series as the gneissose rocks of the north-west Highlands of Scotland. The oldest of the fossiliferous systems, the *Cambrian*, is well represented in the south-east of Ireland, where it attains a thickness of 14,000 feet at least. The strata are upon the whole unfossiliferous, but numerous surface-markings have been detected, chiefly worm-tracks, &c. In many places these rocks have been much metamorphosed. Thus on the Howth coast they are represented by quartz-rocks and schists, while in Wexford they pass into gneiss. Similarly in Galway over considerable tracts the Cambrian seems to be represented by schistose rocks; some of these, however, seem to be of Archaean age. The *Silurian* system is likewise well developed in the island—both lower and upper divisions being present. This system, like the Cambrian, occurs chiefly in the hillier parts of the country. In the Donegal district the rocks are much metamorphosed, and are doubtless the equivalents of the altered Lower Silurian strata of the Scottish Highlands. The same rocks reappear in Mayo and Galway; in the last-named district they are overlaid unconformably by unaltered Upper Silurian sandstones, conglomerates, and shales. Fossils occur here and there in the less altered portions of the Lower Silurian, but are not nearly so common as in the overlying upper division. It is noteworthy that not only are the Upper Silurian strata unaltered, but they contain rolled fragments of the metamorphosed Lower Silurian rocks upon which they rest. It may be added that contemporaneous volcanic rocks are associated with the Upper Silurian strata of Galway. Coming farther south we encounter another thick series of Upper Silurian strata in the Dingle promontory. In the districts of Waterford, Wexford, Wicklow, and Louth Lower Silurian strata are likewise well developed, and are noted for the evidence which they have supplied of contemporaneous volcanic action.

No representatives of the marine *Devonian* are known in Ireland, but the lacustrine or *Old Red Sandstone* type is well developed in the south and south-west. Two divisions are recognised—the upper unconformable to the lower, which latter reaches a great thickness. The rocks of the latter are chiefly grits and slates, which have yielded certain bivalve shells (*Anodonta*), probably of fresh-water origin, but no traces of the marine Devonian fauna. The upper division consists chiefly of flag-

stones and tilestones, and is of no great thickness. The chief fossils are worm tracks and ferns. This division appears sparsely in the centre and north of Ireland, where the general character of the strata recalls that of the Old Red Sandstone of central Scotland. The series passes up conformably into the Carboniferous system.

The *Carboniferous* system occupies about one-half of the area of Ireland, but the strata belong chiefly to the lower division—viz. the Lower Carboniferous and the Carboniferous limestone, which latter is essentially the formation of the plains. The upper members of the system occur in a few detached patches scattered over the surface of the great central plain, the major portion of which was probably at one time covered with Upper Carboniferous strata. The basement beds of the system in the south of the island consist chiefly of marine grits and slates, which pass down conformably into the Upper Old Red Sandstone. In the centre and north this lower division is represented by conglomerates, grits, sandstones, shales, and earthy limestones, which appear to be the equivalents of the 'Calcareous sandstones' of Scotland. Overlying these basement beds comes the great Carboniferous limestone (2500 to 5000 feet thick), which occupies most of the central plain, extending east and west from sea to sea, and stretching from the base of the Donegal Mountains to the foot of the Killarney Mountains in the south. In Donegal the limestone rises into a tableland which overlooks the shores of Donegal Bay in bold bluffs and headlands, and reaches from 1500 to 2000 feet above the level of the sea. Contemporaneous volcanic rocks accompany the limestone series in the south-west (Limerick and Tipperary). In the south and in the north the limestones are overlaid by marine sedimentary deposits which are believed to be on the same general geological horizon as the 'Yoredale beds' and 'Millstone grit' of England. Succeeding this group comes the 'Coal measures' series, the lower portion of which is supposed to represent the 'Gannister beds' or lower coal-measures of England, while the upper portion represents the middle coal-measures of the same country. The productive coalfields of Ireland are of small extent. They are confined to limited districts in the north and south, as in Tyrone, Tipperary, Kilkenny, and Carlow—all the coal of the south of Ireland being anthracitic.

The Upper Paleozoic and Cainozoic rocks of Ireland are confined to the north east of the island, where they appear to owe their preservation in chief measure to the great outflows of basalt which form the high grounds of Antrim. *Permian* strata are very sparingly developed, but both the Lower Permian and the overlying Magnesian limestone of England are represented. The lower division is characterised by the presence of coarse breccias like those of Shropshire. The Permian is seen at Armagh and in Tyrone.

The *Triassic* system is likewise sparingly represented, occurring in a narrow band round the basalts of Antrim and Derry. The rocks are chiefly red and mottled sandstones and marls, with gypsum and extensive beds of rock salt. These strata are overlaid by certain dark shales, which have yielded 'Rhaetic' fossils.

The great *Jurassic* system of England is for the most part unrepresented in Ireland, but a few shales which come out from underneath the chalk escarpment of Antrim have been identified by their fossils as pertaining to the Lower Liás.

Cretaceous strata (Upper Greensand and Chalk) crop out from underneath the basalts of Antrim, to which doubtless they owe their preservation. There is reason to believe that the Cretaceous beds formerly covered a much more extensive area in

the north of Ireland. They may at one time have extended continuously from the high grounds of Donegal in the north-west to the Mourne Mountains in the south-east.

The Tertiary or Cainozoic rocks consist chiefly of volcanic accumulations (trachytes and basalts); their age is determined by the occurrence of intercalated 'leaf-beds,' the plants in which show that the series belongs to the *Oligocene* system. Many of the basalts are beautifully columnar (Giants' Causeway). The volcanic rocks appear to have been the products of great fissure-eruptions for the most part, but the 'necks' or plugged-up throats of isolated volcanic foci have been detected. The whole area in this north-east part of Ireland is traversed in all directions by basalt dykes.

Along the southern shores of Lough Neagh fresh-water clays occur, the fossils in which are of *Pliocene* age, so that this Irish lake is probably the oldest sheet of fresh water in the British Islands.

Ireland, like the sister island, abounds with evidence of the *Glacial* period. The whole country has been buried under a great *mer de glace*, which was continuous with that of Scotland and England. The bottom-moraines (boulder clay) of this ice-sheet are encountered everywhere. Irish geologists recognise two boulder-clays separated by intervening stratified deposits of marine origin (see *PLEISTOCENE SYSTEM*). Local moraines due to the 'retreat' of the great *mer de glace* are common in mountain valleys. *Recent deposits* are seen in raised beaches, alluvial terraces, and bogs.

Ireland's mineral produce is small. In 1896, 129,585 tons of coal were raised; the iron ore is less in value. Salt is made; pyrites, barytes, and lead ore are produced, as well as stone, marble, sand, clay for making aluminium, &c.

Animals.—Twenty-one species found in Great Britain are unrepresented in Ireland. Frogs are common enough, also toads; but the mole, adder, shrew, water-shrew, water-vole, the two land-voles, wild-cat, polecat, weasel, and roe-deer are unknown; only the blue hare is indigenous.

Climate.—The climate resembles that of Britain, but is modified by Ireland's different surface, its greater distance from the Continent, and the more direct influence of the Gulf Stream. The mean annual temperature for the thirty-four years ending with 1889 was 50.0; the annual mean temperature of England is 49.5, that of Scotland 47.5. In Ireland there are 3 of difference between the extreme north and south. In January the mean temperature at inland situations in the north is 39.5, whilst in the extreme south-west it is 45.2; whilst in July the extreme mean temperatures are 58.2 at Malin Head in the north and 60.5 at Parsonstown in the interior. Thus in winter the difference of temperature of different districts is 5.7; but in summer it only amounts to 2.3. Ireland enjoys, therefore, a climate more equable in all seasons than those parts of Great Britain which are within the same latitudes. The mean annual rainfall for the twenty-four years ending 1883 varied from 28.48 inches at Dublin to 89.40 inches at Kylesmore, in Galway. These amounts, which are the extremes, are, however, restricted to very limited areas. About half the whole island has a rainfall of from 30 to 40 inches, and the other half from 40 to 50 inches, the former region being in the east and the latter in the west. Thus the rainfall is very much more equally distributed over Ireland than over Great Britain. The rainfall in winter is greatly in excess of that in the other seasons, particularly in the west, owing to the low temperature of the surface of the ground, which chills the warm and moist south-west winds that prevail at this time of the year. In Great Britain the chief

mountain-ranges are in the west, and lie from north to south; consequently over the whole eastern slope of the island the climate is drier, the amount and frequency of the rainfall much less, and the sunshine more brilliant than in the west. In Ireland, on the other hand, the hills in the west do not oppose such a continuous barrier to the onward progress of the south-west winds, but are more broken up and distributed in isolated groups. Consequently the sky is more clouded, and rain falls more frequently and more generally over the whole of Ireland than Great Britain, and the climate is thus rendered more genial and fostering to vegetation; hence the appropriateness of the name 'Emerald Isle.' Again, owing to its greater distance from the Continent, the east winds of spring are less severely felt in Ireland, because they have acquired warmth and moisture in their progress westward over Great Britain and the Irish Sea. Queenstown, in the south-west of Ireland, enjoys an average spring temperature of 49°, which is about 25° higher than at Dover on the coast of Kent.

Agriculture.—Down to about the middle of the 18th century Ireland was almost exclusively a pastoral country. Yet the soil is in many parts eminently adapted to tillage. The chief reasons of the backwardness of agriculture have been prohibitive and un-suitable legislation, the extreme smallness of the greater number of holdings, the lack of capital, and the unsatisfactory relations of landlord and tenant. As a rule large farms were let for extremely long periods of tenancy, and the tenants sublet their farms in smaller portions, sometimes two or three times over; consequently the landlords seldom erected buildings, repaired farmsteads, or made permanent improvements. In 1879-80 the distress amongst the poorer sections of the community had reached such a pitch that the government took action, and in 1881 the Land Law (Ireland) Act was passed. Its principal measures were designed to protect the tenant from paying more than a 'fair rent,' and to provide for loans being made to tenants to enable them to purchase their holdings on fair and equitable terms. To illustrate the smallness of the holdings in 1841: there were in that year 310,436 holdings above 1 acre and less than 5 acres; 252,799 from 5 to 15 acres; but only 79,342 from 15 to 30 acres, and only 48,625 above 30 acres each. The subjoined table will show the rate at which the small holdings have decreased in number and the larger holdings have increased:

Year.	1 to 5 acres.	5 to 15 acres.	15 to 30 acres.	Above 30 acres.
1871	74,809	171,383	138,447	159,303
1881	67,071	164,945	135,793	169,834
1888	61,816	154,441	133,749	174,245

Of the holdings above 30 acres in extent in 1888, 73,763 ranged between 30 and 50 acres, 56,476 between 50 and 100 acres, 22,796 between 100 and 200 acres, 8,372 between 200 and 500 acres, and only 1561 exceeded 500 acres in extent. In the same year there were 47,951 holdings each less than one acre. Contemporaneously with these changes there has been a steady but very noticeable return to a predominance of pasture, as will be apparent from the variation of acreage shown in the following table:

Year.	Cereal Crops.	Green Crops.	Meadow and Clover.	Flax.
1869	2,208,548	1,460,294	1,670,716	229,252
1879	1,761,867	1,294,600	1,975,255	128,021
1889	1,534,922	1,219,549	2,189,085	113,817

Oats, barley, and wheat, in the order named, are the chief cereals grown. Under green crops are included potatoes, turnips, cabbage, carrots, vetches, and similar crops. The extent of land set apart for potatoes, the staple food of the peasantry, has also decreased very largely: in 1869 potatoes

occupied 1,041,902 acres; in 1879, 842,671; and in 1889, 787,152 acres. About 10 million acres are permanently under grass, and about 330,000 acres are covered with woods. During the last fifty years a relatively large area has been reclaimed and converted into cultivable soil; in 1841 the waste land, including bogs, amounted to 6,489,971 acres; in 1889 the same category included 4,935,649 acres. The next table shows the fluctuations in the number of live-stock at intervals of ten years:

Year.	Horses, Mules, and Asses.	Cattle.	Sheep.	Pigs.
1869	719,421	3,733,675	4,651,195	1,082,224
1879	785,025	4,967,094	4,017,880	1,071,990
1889	910,942	4,933,394	3,789,620	1,389,548

In 1895 there were 1,439,053 acres in corn crops, 1,151,582 in green crops, and 95,202 in flax.

Fisheries.—The seas around the coasts of Ireland teem with fish; but from various causes, chiefly perhaps the distance of the most productive fishing-grounds from the centres of population, the fisheries are not in a flourishing condition. Large quantities of cured fish (3648 tons in 1887) are even imported from Scotland. In 1890-95 the Irish fisheries were prosecuted by 27,000 men and boys in 6000 boats, whereas forty years before 100,000 men and boys were engaged in this calling on 20,000 boats. The deep-sea fish of greatest commercial value are mackerel, herrings, hake, soles, cod, lobsters, and oysters. In 1887 herrings were exported to England to the value of £152,168, mackerel to the value of £88,775, and cod to £142,734. The most prosperous fishing is that for salmon, in which about 13,000 men are employed. The total value of salmon exported in some years amounts to as much as £500,000. The total value of Irish fisheries in 1895 was £269,000, not including salmon.

Manufactures.—Ireland is not and never has been a manufacturing country. Its unsettled state and the general dependence of the population on agriculture have hitherto been obstacles to the formation of great manufacturing establishments, except in the north-east, in Ulster. The staple industry is the manufacture of linen, introduced into Ireland by Strafford in 1633, and much encouraged by the Duke of Ormonde (1661-64). In 1881 the number of spindles employed in this manufacture was 927,300, and of power-looms 21,200; in 1887 the figures were respectively 803,026 and 24,300. The chief seats of the industry are Belfast and other towns in Ulster. In 1889 nearly 1056 flax-scutching mills were employed. The manufacture of woollen, silk, and cotton stuffs and of paper is also carried on, but only to a comparatively inconsiderable extent. In the 17th century the woollen manufactures of Ireland were in a most flourishing condition, producing principally frieze and flannel. But vexatious measures, prohibitive and restrictive, by the English parliament almost destroyed the industry before the century came to an end. Instead of 30,000 persons employed in this industry in 1641, there were only 7710 (in less than fifty factories) in 1881. The silk manufactures, since their introduction by French emigrants in the beginning of the 18th century, have been almost entirely confined to Dublin; poplin is still extensively manufactured there and in a few other towns. In 1890 there were 263 textile factories in Ireland, and nearly 30 distilleries.

Commerce and Shipping. The exportation of agricultural produce constitutes the bulk of the commerce, and by far the greater part of this trade (in cattle, sheep, pigs, salted meat, grain, flour, butter, eggs, and linen) is carried on with Great Britain, chiefly between Dublin and Belfast on the one side and Liverpool, Glasgow, and Bristol on the other. This trade has been assimilated with the coasting trade of the United Kingdom since

1825; consequently no separate statistics of it are kept, except for live animals and fish. Of these, 662,409 cattle, 606,391 sheep, 468,049 pigs, and 31,613 horses were exported to Great Britain in 1889. The foreign and colonial imports, consisting principally of grain, wine and spirits, fruits, petroleum, and timber, were valued at £7,232,669 for the year 1888, and the exports (chiefly linen and spirits) at only £870,873. The number of sailing and steam vessels engaged in the foreign and colonial trade that entered at Irish ports in 1880 was 1737 (tonnage, 960,820), and cleared 1086 (585,052 tons); the number engaged in trade with Great Britain that entered in the same year was 54,742 (12,145,116 tons) and cleared 52,803 (11,588,074 tons). Of vessels engaged in the trade with foreign countries and the colonies in 1888 there entered 1168 (731,285 tons), but cleared only 158 (67,418 tons). In the year 1894-95 the Irish imports were set down at £8,862,000, whereas the *direct* Irish exports were only £332,000.

Government, Police, &c.—The government of Ireland has since the union of 1801 been amalgamated with that of Great Britain. It is represented in the imperial parliament by 28 peers elected for life in the House of Lords and 103 members in the House of Commons. The executive is vested in a lord-lieutenant, who is assisted by a chief-secretary and a privy-council (appointed by the crown). The law is administered by a Lord Chancellor, a master of the Rolls, and the other judges of the Supreme Court of Judicature, which has two divisions—the High Court of Justice, with four divisions, and the Court of Appeal. Besides these, there are three commissioners or judges who preside over the proceedings of the Irish Land Commission, formed in 1881 for the purpose of adjusting 'fair rents' and other disputed matters between landlords and tenants. The Landed Estates Court (established in 1849) has since 1878 formed a branch of the Chancery Division of the High Court of Justice. For the county administration, see COUNTY. The Poor-law and Sanitary administrations devolved in 1872 upon the Local Government Board for Ireland. In 1887 a total of 521,832 persons were in receipt of poor relief, 134,757 getting outdoor relief, and the remaining 387,075 receiving relief in the 161 work-houses. This relief cost £857,820. In 1883 the expenditure reached its maximum, £1,042,845. Order and peace are maintained by the Royal Irish Constabulary, a body of armed police, numbering about 13,500 men, and the Dublin Metropolitan Police, a force of 1226 men. The Crimes Act, repeatedly re-enacted for the prevention of agrarian outrage especially, may at any time be put in force by the proclamation of any district. The Local Government Act of 1898 assimilated the administration of Ireland to that of Great Britain; and a new government department of agriculture, other industries, and technical education was established in 1899.

Religion.—By far the larger portion of the inhabitants of Ireland are Roman Catholics—3,960,891 at the census of 1881, and 3,547,307 in 1891. The Roman Catholic Church of Ireland is governed by four archbishops (Armagh, Dublin, Cashel, and Tuam) and 24 bishops. Irish Protestants numbered 1,159,147 in 1881, and 1,327,535 in 1891. Until January 1871 the established church of Ireland was the Episcopal Church, a branch of the Church of England. Since its disestablishment it is still known as the Church of Ireland, and is presided over by two archbishops (Dublin and Armagh) and eleven bishops. Its members numbered 639,574 in 1881, and 600,103 in 1891. In 1891 the Presbyterians reckoned 444,974 adherents, and the Methodists 55,509; while the Presbyterians had been

470,734 in 1881, and the Methodists, 48,839 in the same year. The relative numbers of Roman Catholics and Protestants of all creeds are shown for the several provinces in the subjoined tabular statement for the year 1881:

	Roman Catholic.	Protestant
Leinster	1,094,825	183,657
Munster	1,249,584	81,653
Ulster	833,593	909,106
Connacht	758,116	38,527

Education.—The primary schools of Ireland are mostly under the management of the Commissioners of National Education. These schools have since 1831 been open to Christians of every denomination, without compulsory attendance at any class of religious instruction, with in fact perfect freedom in all matters appertaining to religion. In 1881 there were 7648 of these schools attended by 1,066,259 pupils; in 1888 the numbers were 8196 schools and 1,060,895 pupils (826,181 Roman Catholics, 109,687 Church of Ireland, and 111,072 Presbyterians). They are partly under Protestant, partly under Roman Catholic teachers, and partly under teachers of both creeds in the same school, and are to a large extent supported by a parliamentary grant (£874,051 in 1887). In 1878 one million sterling, from the former endowment of the Irish established church, was set apart for the encouragement of secular intermediate education. The fund is administered by a board of nine commissioners, who conduct examinations, pay fees according to results, and present exhibitions, prizes, and certificates to successful pupils. In 1887 out of 3931 pupils who presented themselves for examination 3595 passed. The most important university in Ireland is that of Dublin (q.v.) or Trinity College. The Royal University of Ireland is not a teaching, but only an examining body, like the university of London. It was founded in 1880, and superseded the Queen's University; and it grants degrees irrespective of religious confession. The three Queen's Colleges of Belfast, Cork, and Galway, opened in 1849, and formerly affiliated to the Queen's University, provide instruction in the higher branches of learning. They were attended in 1887-88 by a total of 775 students. The Royal College of Science, established in 1867 in Dublin, was founded for the purpose of giving instruction in branches of science applicable to the industrial arts, especially in mining, agriculture, manufactures, and engineering. The Roman Catholic University of Ireland, founded in 1854, has its headquarters in Dublin; it is supported almost entirely by private contributions. St. Patrick's College, Maynooth (q.v.), opened in 1795, is the principal institution for the education and training of Roman Catholic priests. Until 1871 it received an annual parliamentary grant; but in that year this was compounded for by the payment of the sum of £372,331, in lieu of the grants. Two Presbyterian colleges, the General Assembly's Theological College, Belfast, and Magee College, Londonderry, were in 1881 empowered to grant theological degrees to their students. In 1887 there were in Ireland 69 industrial schools for boys and girls, 58, with 6496 pupils, being Roman Catholic, and 11, with 814 pupils, Protestant. In the same year 9 reformatory schools had 891 inmates. In 1888, 21.4 per cent. of the men and 23.2 per cent. of the women who were married signed the register by their mark.

Finance, Taxation. The net amount of revenue raised in Ireland for contribution to the imperial exchequer for the year ending 31st March 1895 was £5,981,896, of which £5,192,722 was derived from excise. In 1896 a parliamentary committee reported that, taking everything into consideration, Ireland was paying much more than her share of

imperial taxation. The national debt of Ireland (about 150 millions) was consolidated with that of Great Britain in 1817, and since that date the former has had no separate debt. The grand-jury cess, a tax peculiar to Ireland, corresponds to the highway rate of England and Wales, and is expended on roads, bridges, quays, prisons, courts of justice, police, public charities, county officers, &c. In 1887 the sum of £2,062,808 was owned by 49,994 depositors in the trustee savings-banks of Ireland, and the sum of £2,802,000 by 158,848 depositors in the post-office savings-banks. In 1894 the capital amount in the latter banks was £4,975,680, and in the former £1,997,495.

Communication.—The first railway opened in Ireland was the short line, of 6 miles long, between Dublin and Kingston, in 1834. In 1895 the number of miles open and in operation was 3044, an increase of 600 miles since 1881. The companies having the longest mileage are the Great Southern and Western, the Great Northern, the Midland Great Western, the Waterford and Limerick, the Belfast and Northern Counties, and the Dublin, Wicklow, and Wexford. The railways are constructed on a broader gauge than those of Great Britain—viz. 5 feet 3 inches, as compared with 4 feet 8½ inches; but several built since 1878 (see RAILWAYS) are only of 3 feet gauge. The local authorities have sanctioned the construction of 600 miles of tramways. The first considerable electric tramway in the United Kingdom was that from Portrush to the Giant's Causeway (1883). The canals, rivers, and lakes have been already mentioned. In the year 1894-95 the postal authorities in Ireland despatched 113 millions of letters and 65 millions of post-cards, newspapers, and parcels, and 4,038,262 telegrams, and issued 536,714 money orders (exclusive of postal orders) representing the sum of £1,364,000.

BIBLIOGRAPHY.—The earliest account of Ireland is contained in Giraldus Cambrensis, *Topographia Hibernia* and *Erpugnatio Hibernia*. Subsequent accounts will be found in Holinshed, *Chronicles* (1577); R. Payne, *Brief Description of Ireland* (1590); E. Hogan, *Descr. of Ireland in 1598* (1878); Sir J. Davies, *Discovery of the State of Ireland* (1613); Edmund Spenser, *Vicr of the State of Ireland* (1633); Sir Wm. Petty, *Political Anatomy of Ireland* (1691) and *Geog. Descr. of the Kingdom of Ireland* (1700); Arthur Young, *Tour in Ireland* (1780); César Moreau, *Past and Present State of Ireland* (1827); G. de Beaumont, *L'Irlande, Sociale, Polit., et Religieuse* (1839); Thackeray, *Irish Sketch Book* (1843); S. C. and Mrs Hall, *Ireland; Scenery, Character, &c.* (1843); Sir Robert Kane, *Industrial Resources of Ireland* (1844); G. L. Smyth, *Ireland, Hist. and Statist.* (1844-49); Harriet Martineau, *Letters from Ireland* (1853); Dufferin, *Irish Emigration and Tenure of Land in Ireland* (1867); J. M. Murphy, *Ireland, Industr., Polit., and Social* (1870); O'Curry, *Ancient Manners and Customs of Ireland* (1873); Thebaud, *Irish Race in Past and Present* (New York, 1873); Lesaulx, *Ass Ireland* (1877); Hull, *Physical Geology and Geog. of Ireland* (1878); Kinahan, *Manual of Geol. of Ireland* (1878); O'Brien, *Hist. of Irish Land Question* (1880); Richey, *Irish Land Laws* (1880); Sir Charles Russell, *New Views on Ireland* (1880); Shand, *Letters from West of Ireland* (1885); Robert Dennis, *Industrial Ireland* (1887); E. Lynn Linton, *About Ireland* (1889); J. B. Daly, *Gleanings of Irish Industries* (1889). For comparative statistics of Ireland and Great Britain, see GREAT BRITAIN; see also BREHON LAWS, LAND LAWS, TAXATION, &c.

HISTORY.—The history of Ireland, like that of almost all ancient countries, tracks its parent lake back into the enchanted realms of legend and romance and fable. It has been said, not untruly, of Ireland that she 'can boast of ancient legends rivalling in beauty and dignity the tales of Attica and Argolis; she has an early history whose web of blended myth and reality is as richly coloured as the record of the rulers of Alba Longa and the story of the Seven Kings.' We cannot

now make any effort to get at history in the beautiful myths and stories. We should puzzle our brains in vain to find out whether the Lady Cesair who came to Ireland before the deluge with fifty women and three men has any warrant, even the slenderest, from genuine tradition or is a child of fable altogether. We cannot get at any hint of the actual truth about Conn of the Hundred Fights and Fin Mac Coul and Oisín. But the impression which does seem to be conveyed clearly enough from all these romances and fables and ballads is that there was in Ireland a very ancient civilisation, and that the island was occupied in dim far-off ages by successive invaders who came from the south. The Phœnicians are said to have represented one wave of invasion and the Greeks another. Many an observer who had little in him of the merely fanciful has left it on record that in his opinion the Celtic Irish even still give evidence that they are the descendants of a southern people. Nemedians, Fírbolgs, Tuatha de Dananns, and Scots are reported to have successively planted themselves in an island which before their coming was probably the home of an Iberian people. What may be called the authentic history of Ireland begins with the life and the career of St Patrick. Patrick was born in Scotland, and in his early youth he was carried as a slave to Ireland. He escaped to Rome, and rose high in the service of the then united church. Somewhat early in the 5th century he returned to Ireland with the object of converting the island to Christianity. He accomplished his mission completely, and he even made Ireland the great missionary school for the propagation of the faith all over Europe. At this time Ireland was divided into septs or clans, each sept bearing the name of the head of the family. The septs all owed allegiance to the chief king. All the chieftainships were elective, and during the lifetime of each chief his successor was chosen from the same family, and was called the Tanist. All the land was held by the septs for the benefit of the people, and there was no feudal condition, and no system of primogeniture. Near to the close of the 8th century the Danish sea-rovers invaded Ireland and overran great part of it, and made settlements on the eastern coasts. The Irish chiefs were divided among themselves and could not keep out the enemy, and the Danish occupation lasted for much more than a century. At last, in 968-984, a strong and capable Irish chieftain, Brian Bóroinhe, brother of the king of Munster, defeated the Danes, and, although he did not drive them out of the country, he reduced them to the condition of subdued and submissive residents. Brian now made himself king of Ireland, and for twelve years reigned a successful ruler over a peaceful and prospering country. As he grew old the Danes plucked up spirit again, and got a fleet and an army from their kinsmen across the sea to invade Ireland. Brian, old as he was, proved himself equal to the occasion. He completely defeated the Danes at Clontarf, but was killed in his tent at the end of the battle by one of the enemy, 23d April 1014. There were no more Danish invasions; but the Danish settlers continued to occupy the seaport towns of the east, and in time became absorbed into the common population of the island.

A far more momentous event in the history of Ireland was the Norman invasion (1167-72). This took place in the reign of Henry II. (q.v.), and is another story of Helen of Troy, and of Virginia, and of the fabulous Florida who was said to have been loved not wisely but too well by Roderick the Goth. The king of Leinster carried off the wife of the chieftain of Brehni. The injured husband made war upon his wronger; the king of Leinster was

getting the worst of it, and fled to England, and induced Henry II. to lend him countenance and even help. Henry had before this received a bull from Pope Adrian IV., an Englishman, authorising him to assume authority over Ireland, in order that Ireland might be made more submissive than she was to the ecclesiastical direction of Rome. Henry now took the opportunity offered him by the fugitive king of Leinster, and allowed if he did not authorise a sort of 'Free Companions' invasion of Ireland, and afterwards came over himself to finish the conquest. The Irish kings and chiefs fought fiercely, but the Normans were far better armed, and in fact the story of the Norman invasion of England was told over again in Ireland. Henry organised the country after the Norman fashion as well as he could. He divided the island into counties, and set up the courts, King's Bench, Pleas, and Exchequer in Dublin. He allowed the native Irish, however, to keep to their time-honoured system of Brehon law. He made huge grants of land, the septal property of the island, to his favourite Norman barons, leaving the barons to hold the granted land in the best way they could. So began the great land struggle in Ireland which has lasted down to our own days.

The history of Ireland for a long time after the settlement of the Normans becomes nothing but a monotonous recital of the struggles between the Norman barons and the Irish chieftains, and the struggles between one Irish chieftain and another. The Norman or English barons lived within the enclosure of their own domains and administered affairs on the feudal system. The English territory was known as the Pale. Outside were the Irish, who still strove hard to keep up their own laws, their own customs, and their own civilisation. English law did not extend any of its protection to them. They had no rights which a Norman was bound to recognise. As time went on, however, a curious change was taking place. The English began to be drawn very much towards Irish ways and Irish people. They took to marrying Irish women and speaking the Irish language. This mingling of races alarmed the government in England, and the severest enactments were passed forbidding the adoption by English settlers of Irish names, speech, customs, or garb. One especially cruel edict ordained that any Englishman who married an Irish wife was to be mutilated in a horrible way and then put to death. It was not found possible, however, to put such laws in force often enough to prevent the blending of the races. The Englishmen still married the Irishwomen. The great Norman family of the Geraldines was described as more Irish than the Irish themselves. By the time that Henry VII. had come to the throne the greater part of the island was in the hands of Anglo-Irish chieftains. There was a parliament on the Norman idea sitting in Ireland and illustrating at least the principle of a representative system. Henry VII. seemed inclined at first to leave the Geraldines to manage Ireland in the best way they could; but when the Geraldines supported the cause of Perkin Warbeck and Lambert Simnel, Henry retaliated on them and on Ireland. He sent over Sir Edward Poyning's as lord-deputy, with a strong army at his back and with ample authority to make a great change. Poyning's summoned a parliament at Drogheda, and compelled it to pass the famous measure known as Poyning's Act (1494). This act declared that all English laws should have force in Ireland, and that all legislation in the Irish parliament should be confined to measures which had been first approved of by the king and the Privy council in England. Poyning's Act is an epoch in the history of Ireland.

Henry VII. died. The Geraldines defied the power of Henry VIII. The rebellion of 'Silken Thomas' broke out. 'Silken Thomas,' so nicknamed because of the splendour of his dress, was Lord Thomas Fitzgerald, and he proved himself of stronger stuff than silk. He raised a desperate revolt against the king, but after a hard struggle he was defeated, and he and his five uncles who had taken up arms with him were brought to the Tower of London and hanged. Henry confiscated the church lands in Ireland exactly as he had done in England. A parliament was summoned in Dublin at which, for the first time, some of the Irish chieftains were seen sitting side by side with Englishmen. These were certain of the Irish princes who had agreed to hold their lands as the gift of the crown, to attend the king's parliament and seek justice in the king's courts, to send their sons to be educated in England, and to renounce the authority of the pope. This parliament conferred on Henry and his successors the title of King of Ireland instead of Lord Paramount, the former designation of the sovereign. A weary chapter of struggle followed the death of Henry VIII. Henry had done his best to compel the Irish chieftains and people to give up the faith of Rome and adopt what was now the faith of the majority in England. This was but a new source of bitterness and strife. The great family of O'Neill raised its head higher than ever, and the chief whom, in defiance of English law, it elected to that place, Shane O'Neill, was actually able to make terms with Elizabeth. The Geraldine League was formed. Walter Devereux, the first Earl of Essex, was sent over in 1573 to put down the O'Neills; but although he slaughtered whole masses of them he could not extirpate them. A chronic state of civil war prevailed. After each new rising had been put down there was a new consolidation of territory, a new planting of English and Scottish settlers, and a new attempt to expel or extirpate the native Irish. 'Red Hugh O'Neill' was the most distinguished rebel who had yet appeared in Ireland. He was the grandson of an O'Neill who had consented to accept from Henry VIII. the title of Earl of Tyrone. Hugh O'Neill had been brought up at the court of Elizabeth, and was accounted an ornament of even that most brilliant circle. He was confirmed in his title of Earl of Tyrone. But when he went back to his own country he seems to have found blood thicker than water, for he resumed his ancestral title of 'The O'Neill,' and put on all the ways of an independent Irish prince. He did not at first go into open rebellion; but 'rebellion lay in his way, and he found it.' Whether he was driven into it by the intrigues of English agents and officials, or whether he of his own motion struck for the independence of the country, it would not now be easy to decide. He put himself at the head of a great rebellion of the chiefs, and he won a complete victory in Ulster over Sir Henry Bagenal, the lord-marshal. Bagenal himself was killed. There was something romantic about the encounter of these two opponents. Some time before, O'Neill, then a widower, had fallen in love with Bagenal's beautiful sister. His love was returned, and the lady eloped with him and became his wife. The river Blackwater saw her brother's defeat and death. For a while fortune seemed to smile on Hugh O'Neill. Robert, the second and most famous Essex, was despatched in 1599 to defeat him, with the largest army ever sent into Ireland up to that time; but Essex could do nothing. He was out-generalled and outwitted by the Irish chief, and went back to England and his death. Lord Mountjoy, a stronger soldier, was sent to Ireland in his place, and he at last succeeded in defeating Tyrone and putting down

the rebellion. O'Neill had to come to terms, and to renounce all his claims as independent Irish prince. Elizabeth died, and James I. accepted the surrender.

But James had set his heart on getting rid of all the Irish laws and usages of the country, and if possible putting down the Roman Catholic religion. Tyrone and another Irish chief, Tyrconnel, fled from the country which they saw they had no longer the power to maintain, and both died years after in Rome, and were buried there. 'The flight of the earls,' as it is called, left the island completely in the hands of King James. There were again vast confiscations and new settlements. When King Charles succeeded to the throne and came into trouble with his people some of the Irish chiefs thought their opportunity had come. The native Irish in Ulster rose under Sir Phelim O'Neill, not so much against English rule as against the Scotch and English settlers who had been planted there. In that rising, following on the eight years' administration of Strafford (q.v.), occurred what is called 'the massacre of 1641.' So far as one can form any judgment it does not seem as if there was any deliberate and purposed massacre of the Protestants, although it is impossible to doubt that there was a very barbarous slaughtering of Protestants in one place. The struggles of that time indeed show over and over again hideous incidents which can hardly be described as anything but massacres. The question in this case is, was there a conspiracy to massacre the Protestant settlers—was that the conspiracy—or was there a conspiracy for a rebellion, in the outbreak of which a slaughter of a great number of Protestants was a ghastly incident? Mr Goldwin Smith, who certainly is not in much sympathy with Irish historians, gives it as his conviction that the massacre was 'unpremeditated and opposed to the policy of the leaders,' and that in any case it was not so bad as some of the massacres done by the other side. The rising soon became something very like a national rebellion. Colonel Owen O'Neill, nephew of the gallant Tyrone—Owen Roe O'Neill, as he is always called in Irish song and history—came over to lead the struggle. He had won a high place in the Spanish army. At first his arms in Ireland were all successful. A parliament was held in Kilkenny—a national convention—in October 1642, to proclaim and establish the independence of Ireland. The papal nuncio Rinuccini came from Rome to give his counsel and support to the movement. Charles himself favoured the Irish, and made many pledges to them in the hope of getting their help. His hour, however, had come; his struggle was over, and his execution left Cromwell free to take Ireland in hand. The only man in Ireland capable of meeting Cromwell on a battlefield with any chance of success was unquestionably Owen Roe O'Neill; he had already won one victory over the English forces, but before he had time to throw himself across Cromwell's path Owen died. He died so suddenly that the common belief of the Irish people was that he had been done to death by poison. There seems no good ground for assuming anything of the kind; but the death, so sudden, and for the Irish so untimely, made the suspicion and even the belief quite natural. With O'Neill's death was gone the first and the last and the only chance of any success for the Irish movement. Cromwell's march was from victory to victory. He stamped out the rebellion with merciless severity, and then, like all his victorious predecessors, he went in for a re-settlement of the island. Cromwell's was a re-settlement with a vengeance. He seems to have contemplated such a plantation of the whole country with English and Scotch settlers as would render any further rising of the Irish impossible,

and indeed would before very long lead to the positive extirpation of the Catholic Celts. All Ireland, except Connaught alone, was portioned out among the settlers. Connaught was set apart as a sort of reservation into which the unfortunate Irish were literally driven, and where they were cooped up within certain prescribed limitations. Irish women and girls were shipped off in thousands for virtual slavery or worse in our West Indian possessions.

The Restoration brought the Irish little good, for Charles II. was more anxious to conciliate the Cromwellian settlers than to restore the Irish owners. James II. came to the throne, and the Irish Catholics got better treatment, and in consequence showed a very fervour of loyalty to him. They championed him with all their might when he quarrelled with his people and fled from his throne. The Irish were in all these struggles invariably the losers. They supported Charles I., and brought Cromwell on them; they supported James II., and brought William III. on them. William defeated James at the battle of the Boyne (1690) and on other fields. Limerick held out to the last. It was defended by a brave soldier and true patriot, Patrick Sarsfield—Mr Disraeli once declared in the House of Commons that every true Irishman was proud of 'the sword of Sarsfield'—and William's generals could not capture it. A treaty was made which promised religious freedom to the Catholics and to King James's followers the right to their estates. Then Sarsfield and his soldiers marched out with all the honours of war, and passed away into the service of foreign lands to meet the soldiers of England on many a continental battlefield. The treaty was broken almost immediately after it had been made. King William, who was in Holland at the time of the surrender of Limerick, would have upheld it if left to himself; but the opinion of his English supporters was fierce against the Catholics, and the result of the gallant defence and the honourable and patriotic surrender of Limerick was a series of new penal laws imposed on Ireland with the avowed purpose of extinguishing Catholicism in the island. These laws have in fact ever since been known as 'the penal laws'—*penal par eccellence*.

The two great struggles in Ireland were the religious struggle and the land struggle. The first was part of the great controversy going on all over Europe for the Church of Rome and against it. The main effort of English statesmanship was to extinguish Catholicism in Ireland. The land struggle began with the determination to impose on Ireland a system of land tenure foreign to her habits and traditions, and later on to take the land from the Irish people and give it to the imported settlers. Under William III. the religious struggle became aggravated; the land struggle was not mitigated; and laws were even passed to crush the rivalry of Ireland in various branches of manufacture and of trade. The island sank into wretched poverty, and when the two successive outbreaks of the Stuarts took place, in 1715 and 1745, Ireland, although undoubtedly in deep sympathy with the cause, was too weak to lift a hand in its support. The rights of the Irish parliament were still further curtailed under Anne and under George I. In the reign of George the appellate jurisdiction of the Irish House of Lords over Irish cases was taken away by an act of the English parliament. The Irish parliament was a very poor specimen of a representative institution. Since William III.'s time it was barred against Catholics. To the vast majority of the Irish people its existence might have been a matter of absolute indifference. Yet the sympathies of the country went with the Irish parliament simply because it was

called an Irish parliament, and represented even in name the authority of the Irish people. Gradually there began to grow up in Ireland a popular party led by Protestants, who agitated for the restoration of its independent legislative power to the Irish parliament, and for the reform of that parliament in such a manner as to make it really representative. Grattan and Flood were most prominent in this movement. The war with the American colonies gave an opportunity to the popular party to drive home their demands. A great volunteer force had been organised in Ireland to defend the country, as England could not spare troops for its defence. The volunteers were entirely in sympathy with Grattan, and when the war was over they sustained him in his demands. English statesmen very wisely gave way, and in 1782 the Irish parliament was declared to be an independent legislature—the King, Lords, and Commons of Ireland to make laws for the people of Ireland. An immense impulse was given to popular agitation by this victory. The volunteers were disbanded by Grattan's advice. The new parliament was exclusively Protestant, and was elected by an exclusively Protestant vote. Yet its leaders at once went to work to obtain the emancipation of their Catholic fellow-subjects. Grattan succeeded in obtaining an act to admit Catholics to practice at the bar. He then carried an act to enable Catholics to vote for members of parliament. He went further still; he strove for a measure to enable Catholics to sit in the Irish parliament. In this object he was assisted and encouraged by Lord Fitzwilliam, the viceroy of Ireland. This was too much for George III. The king took fright at the advance made towards full emancipation of the Catholics, and at the very time when the Irish people thought they were near to a peaceful consummation of their hopes, the viceroy was suddenly recalled, and all immediate hope of Catholic emancipation blighted.

There had been a society formed during the agitation called the Society of United Irishmen. It was formed as a merely peaceful organisation to assist Grattan in the carrying of his reforms. It was got up and officered almost exclusively by Protestants; many of them young men of rank and influence, like Lord Edward Fitzgerald. In the anger caused by the recall of Lord Fitzwilliam, and in the despair of any peaceful movement, the United Irishmen became a rebel organisation. The war with France was going on. Napoleon was the rising sun of the French people. Wolfe Tone, a daring young Protestant, went over to France and pleaded the cause of Ireland there. Napoleon took it up merely because he thought an Irish rebellion might be fostered into a diversion in his favour. A French fleet was sent, but was dispersed by a storm like another Armada. A landing was made in one place, but only by a very small force, who were soon defeated and captured. The rebellion broke out in the south, and there was some fierce fighting, but it was crushed. It had indeed, owing to the French failures, been only a series of disconnected local risings. It was crushed with remorseless severity, and deeds of cruelty were perpetrated by the soldiery and the yeomanry who the then commander-in-chief, Sir Ralph Abercromby, deplored and cried out against, but was wholly unable to repress, and which the viceroy lamented and denounced both at the time and after. When the rebellion was put down Pitt thought the condition of things could only be bettered by adopting, with regard to Ireland, the same policy that had been adopted with regard to Scotland, and uniting the two islands under one common parliament. Grattan and his leading colleagues, among whom was Sir John Parnell, fought to the last against the

policy of union, but they were overborne. There can be no doubt that very unscrupulous measures were employed to get a majority of the Irish parliament to pass the act. Some attempt has lately been made to show that the money spent was not spent in purchasing votes, but only in compensation for extinguished proprietorial rights over constituencies. Certainly Lord Cornwallis, the viceroy who carried the Act of Union, was not under any such impression. He understood that he was commissioned to bribe, and he executed his commission faithfully, while he frankly detested the work, and said so. The Act of Union came into force on the 1st January 1801. There had been a promise held out to the Irish Catholics that the union should be a preliminary to their prompt emancipation, but King George would not hear of any such concession, and his ministers did not venture to press it on him. The Act of Union was followed almost immediately by the abortive and hopeless rebellion of Robert Emmet. Then a long dark night of conspiracy, agrarian and political, came on. A great movement was made for Catholic emancipation. The movement was led by Daniel O'Connell, and became successful after O'Connell had defied the law, presented himself as a candidate at the Clare election in 1828, and been returned by a great popular majority. It had become a mere alternative between concession and rebellion, and the Duke of Wellington, like the brave old soldier that he was, declared he had seen too much of war and would not have a civil war, and so prevailed on George IV., and the Catholics were enabled to sit in parliament. The tithe struggle was for a long time a source of the bitterest trouble and the most frequent bloodshed, but a settlement was at last effected by means of which the tithe-collector and the peasant were no longer brought into collision.

In 1842 O'Connell started a great agitation for repeal of the Act of Union, and held 'monster meetings,' as they were called, and at one time seemed to be on the verge of driving the country into rebellion. O'Connell, however, had no such purpose, and when the younger and more fiery of his followers found this out they broke away from him altogether. O'Connell died while the horrors of the great famine of '46 and '47 were still on the land, and in the following year, 1848, the poetic, impassioned, ardently-sincere Young Ireland party broke or drifted into rebellion. The rebellion was easily put down—hardly a drop of blood was shed. But the Young Ireland movement had undoubtedly revived the national feeling in all its intensity. There was a 'Phoenix' conspiracy, as it was called, in 1858, and a Fenian movement in 1867. The existence and the succession of all these movements convinced men like Mr Bright, and afterwards Mr Gladstone, that there was much in the state of Ireland which called for reform and reconstruction. Mr Gladstone set to work with characteristic energy. He disestablished and disendowed the Irish state church—a church which ministered to the spiritual wants of not quite one in five of the Irish population. He passed a series of measures to give better security of tenure to the Irish tenant farmer, to entitle him to compensation for improvements he himself had made if he were to be ejected from his land, and to help to found a peasant proprietary in Ireland. A Land Commission—it might be called a Land Court—was formed which had the power of reducing rents where reduction seemed necessary and rightful, and fixing the rent for a certain number of years. More lately, a Land Purchase Commission was created, the function of which is to assist tenants in buying their farms from the landlords, by an advance, under certain conditions as to repayment, of a large

portion of the purchase money. These measures are in fact part of a great agrarian reconstruction which is still going on in Ireland, and to which Conservative governments as well as Liberal have made contribution. Meantime a fierce struggle had been raging between the peasantry and some of the landlords, the former supported by the popular and powerful Land League. There was much disturbance in Ireland, and Coercion Act after Coercion Act was passed. A Home Rule party had been formed, and out of this party sprang a small but very determined body of Irish Nationalist members who, under the leadership of Mr Charles Stewart Parnell, a descendant of the Sir John Parnell already mentioned, set themselves to force the claim of Ireland on the attention of the English parliament and public by a system of persistent obstruction of all business in the House of Commons. In May 1882 the whole civilised world was horrified by the murder of Lord Frederick Cavendish, newly appointed secretary to the lieutenant of Ireland, and Mr Burke, the permanent under-secretary. The murderers were proved to be a gang of miscreants banded together secretly for the perpetration of such crimes. They were betrayed by some of their own associates, were found guilty, and some of them were executed. The Home Rule agitation went on growing stronger, and at last, when a new Franchise Bill had given a popular suffrage to Ireland as well as to England, the Home Rule party carried off eighty-six seats out of one hundred and three which make up the Irish representation (1885). Mr Gladstone (q.v.) brought in his first Home Rule Bill in 1886, but this was defeated in the Commons by the united Conservatives and Liberal Unionists; a second Home Rule Bill was passed in the Commons, but defeated in the Lords in 1892. Under Mr A. J. Balfour (1887-91) and his brother Gerald (1895-1900), as secretaries, Ireland prospered; and men of all parties and faiths combined in an association to promote dairying, trade, and commerce. The Local Government Act of 1898 has been named above; the Queen's visit in 1900 deserves record, her recognition of the gallantry of the Irish soldiers in South Africa by the permission to wear the shamrock on St Patrick's Day, and the formation of a regiment of Irish Guards. A new departure was made by the Nationalists under Mr O'Brien and Mr Redmond in 1900-1901.

See Plowden's *Historical Review of the State of Ireland* (1811); Moore's *History of Ireland* (4 vols. 1839); Donovan, *Annals of the Kingdom of Ireland by the Four Masters* (3 vols. 1818); *Correspondence of Lord Castlereagh* (12 vols. 1847-53); *Papers and Correspondence of Lord Cornwallis* (3 vols. 1859); Lecky's *Leaders of Public Opinion in Ireland* (1861; new ed. 1871-72); Prendergast's *Cromwellian Settlement of Ireland* (1865; new ed. 1870); Darcy McGee, *Popular History of Ireland* (1869); Froude's *English in Ireland in the 18th Century* (3 vols. 1871-74); Alfred Webb's *Irish Biography* (1879); Keating's *History of Ireland* (1880); Duffy, *Young Ireland* (1880); Walpole's *Short History of the Kingdom of Ireland* (1882); J. H. McCarthy's *Outlines of Irish History* (1883); Lady Emily Lawless, *The Story of Ireland* (1888, 'Story of the Nations' series); Richey, *Short History of the Irish People* (1888); Stokes, *Ireland and the Celtic Church* (1888), and his *Ireland and the Anglo-Norman Church* (1889); Sophie Bryant, *Celtic Ireland* (1889); *Two Centuries of Irish History, 1691-1870*, with Introduction by Bryce (1889); Ball's *Historical Review of the Legislative Systems in Ireland, from the Invasion of Henry II. to the Union* (1889); speeches and writings of Burke; speeches of Grattan, Curran, Flood, O'Connell, Meagher, Isaac Butt. See also BUTE, CASTLEBROUGH, CELTS, CROMWELL, DUBLIN UNIVERSITY, EDUCATION, EVICTION, FEINTANS, GLADSTONE, GRATTAN, O'CONNELL, ORANGEMEN, PARNELL, PITT, STRAFFORD, WHITELOYS, and works cited under these articles.

LANGUAGE AND LITERATURE.—The native language is Gaelic—Irish Gaelic as distinguished from Scottish and Manx Gaelic, the three constituting the Goidelic branch of the Celtic language (see GAELIC LANGUAGE AND LITERATURE). The old grammarians sometimes designated their language or departments thereof by different epithets. *Bétra*, now *Beurla*, meaning the English language exclusively, was the general term for 'speech.' A dialect of Gaelic was called *bétra Fionn*—named, it is said, after *Fionn*, a mythical grammarian. This term was afterwards restricted to the 'language of law,' while *bétra bin*, 'fair speech,' was used to designate the 'canon.' According to Cormac *úrbétra* meant 'obscure speech,' and that old lexicographer gives *onn* as the *úrbétra* for 'stone,' *clach* being the *quoth bétra* or common term. Bede informs us that the language of the Picts or *Cruithnig*, to use the Gaelic name, was a separate language; and Cormac, already mentioned, notes *cait* a *dealg* or 'pin' as *bétra Cruithneach*, or a Pictish word. The writer of an old grammatical treatise, preserved in the *Books of Ballymore* and *Liscan* and in MS. I. of the Scottish Collection of Gaelic MSS., professes to give the form of the third person singular of the personal pronoun not merely in the language of the Milesians or Gaels, but also in that of the mythical Firbolgs and Tuatha dé Danann; Gaelic *isise*, *issi*, *issid* (masculine, feminine, and neuter respectively); Firbolg speech *winibus*, *winusi*, *anuor*; Tuatha dé Danann *uol*, *tol*, *trouth*. Elsewhere Cormac gives *toth* as a technical term for the feminine gender and *trouth* for the neuter.

In Ireland the language was less subjected to corrupting influences than in Scotland and in the Isle of Man, and it was more carefully cultivated. The diction of Irish Gaelic is accordingly more copious, and the grammatical forms are fuller. The Norse language, which displaced for a time the native tongue in the Hebrides, hardly took root in Ireland. In the names of three of the four provinces the Norse suffix *ster* appears, but the Scandinavian element in Irish topography as compared with that of the north-west Highlands and the Isle of Man is very small. The English language found its way to the country in the 12th century, but for very many years its advance was slow. As is well known, several of the leading English settlers became ardent students and patrons of the native language and literature. Of the Burkes, the Butlers, the Keatings, and Geraldines it used to be said in this regard that they were *ipsis Hibernis Hiberniores*. Beyond the 'pale' the native laws and ways flourished in full vigour in the 17th century. And even in the more purely English districts Gaelic was commonly spoken. Dr Norman Moore (*Bartholomew Hospital Reports*, xi. p. 146) quotes an edict of the year 1655 ordering all Irish Papists and all Protestants unable to speak the English tongue to leave Dublin before June 20 of that year. But for the last 300 years English has been steadily and with ever-increasing pace gaining ground. The seeds of decline of the native tongue were sown even earlier. The revival of learning which spread over the west of Europe in the 15th century hardly touched Gaelic territory. The impetus given to the cultivation of the native language in Wales and even in the Highlands of Scotland by the Reformation was scarcely felt in Ireland. The views of men in power were hostile to the study of Gaelic. The plantation of Ulster by James I. in the beginning of the 17th century, together with repressive measures of a severe character afterwards adopted, checked the production of native literature and gave an impetus to the spread of English among the people. Within recent years

increased facilities of communication with England, Scotland, and America; the advance of education; the extension of the surlage; the social and political movement of our own day—all contribute to the increasing use of the English language, but without reducing to the same extent the number of persons able to speak the old tongue. In the decade 1871 to 1881 the Gaelic-speaking population of Ireland actually increased. The number who spoke Irish-Gaelic only in 1881 was 64,167, as against 103,562 in 1871; but while there were only 714,313 bilinguals in 1871, the number of such persons increased by 1881 to 885,765. So that the total able to speak Gaelic in 1881 was 949,932, while in 1871 the number of such persons was returned at 817,875. The current decade will very probably show decrease under both heads, but a greater diminution proportionally in the number of persons able to speak Gaelic only than in the class of bilinguals. Many emigrants fondly cherish their mother-tongue in America, and in the United States one or two newspapers print occasional contributions in Irish-Gaelic; but the language is not destined to flourish on its native soil.

The rich literature of Ireland has been preserved to us in inscriptions and manuscript. The oldest inscriptions, found in the south-west of Ireland, are written in a peculiar script called Ogham (q.v.). Native writers made occasional use of this primitive and withal clumsy mode of writing long after they became acquainted with the Roman alphabet, for we find specimens in such MSS. as the Priscian St Gall, and even in quite modern documents, as e.g. in MS. XXXV. of the Scottish collection. A few of the Ogham inscriptions are bilingual, Gaelic and Latin, so that the readings of the mingled Oghams are established. The oldest of them date as far back as 500 A.D. The linguistic forms would suggest even a higher antiquity. Thus, for example, the genitive of masculine O-stems ends in *i*—*magi*, *mailagui*, forms on the same platform with the Old Gaelic inscriptions *Aleguati*, *Druticeni*, and for that matter with classical Latin—*Mavimi*, *domini*. The oldest MS. forms are *maice* and *mailain*, the terminal *i* disappearing as a separate syllable, but becoming incorporated in the preceding syllable in order to preserve the sound of the consonant. This great grammatical change in the short interval between the period of the Ogham inscriptions and the oldest MSS. may, in part at least, be explained by the disturbing influence of the Latin language introduced by the early clerics. Inscriptions in Roman characters are found with greater or less interruption down to our own day.

The Ogham inscriptions have been published, among others, by the late Mr Brash, *Ogham Inscribed Monuments of the Gaoidhel* (1879); the late Sir Samuel Ferguson, in various publications; while the grammatical forms which they exhibit have been explained by Professor Rhys, *Lectures on Welsh Philology*, Lecture vi.; Mr Whitley Stokes, D.C.L., *Beitr. zur Feigl. Sprachl.*, v.; 'Celtic Declension'—*Trans. of Phil. Soc.* (1885), and *Beitr. zur Kunde Indogerm. Sprachen*, xi.; Mons. H. d'Arbois de Jubainville, *Études sur le Druid. Celtique*. The inscriptions in Roman character, chiefly collected and drawn by the late Dr George Petrie, have been published by Miss Stokes, *Christian Inscriptions in the Irish Language* (1872-78).

The MS. literature dates from the end of the 7th or the beginning of the 8th century. The Roman cursive hand of the 5th century was introduced by St Patrick and his companions into Ireland, and has been adhered to with characteristic tenacity to this day. Only eighteen letters were permanently adopted; *a, b, c, d, e, f, g, h, i, l, m, n, o, p, r, s, t, u*. *A* is used to express the numeral 10, occasion-

ally to represent the combination *ca*; *q* stands for *cu*; *k* frequently for *ca* and *cath*, 'battle'; *y* and *z* are met with in one or two loan-words—*ymnon*, a 'hymn'; *Zephon*, 'Stephen.' The oldest preserved MSS. are in Latin. Over 200 such, written by Gaelic scholars before the year 1000, still remain, all with the exception of some half a dozen in France, Germany, Switzerland, and Italy. They were written by the distinguished missionary and scholar Columbanus, his companions and followers, or carried abroad during the 8th and 9th centuries.

Ósú n̄ m̄ar ro do d̄r̄áe n̄s̄ D̄ia an̄ t̄óim̄an, zo
 t̄euz̄ ré ā éim̄zeim̄ D̄h̄eic̄ féim̄, ioh̄ur̄ zō bé
 é̄rētear̄ āh̄ n̄ac̄ rācād̄ ré ā m̄ú̄za, āc̄t̄ zō m̄bēr̄é
 an̄ b̄ētā r̄ioim̄r̄ē āze.

John, iii. 16 in Irish, as printed by the British and Foreign Bible Society. The following is the translation in Roman letters: Ouis mar so do dhráidhugh Dia an domhan, go dtug se a enghen Meic fe n, ionus goib he chroicreas ann, nach raicadh se a tughá, achd go mbeith an bheatha shiorrudhe aize.

One occasionally finds a Gaelic quatrain on the margin of these MSS., as in the Priscian St Gall, or a short poem on a blank page, as in the Milan and Carinthian Codices. There is a fragment of a sermon in old Gaelic in the town library of Cambray; and still more valuable are the Annotations on the *Book of Armagh*, written in the early part of the 9th century. But the most important remains of old Gaelic are full glosses on about a score of the Latin MSS. on the Continent. Three such are specially noteworthy: a copy of Priscian's Grammar in the library of St Gall; a copy of St Paul's Epistles in the university of Wurzburg; and a commentary on the Psalms of David by Columbanus, now in the Ambrose Library, Milan. The glosses on the Milan Codex are so voluminous that, according to Stokes, a very complete grammar and dictionary could be compiled from them alone.

The oldest Gaelic MSS. now existing were written by the end of the 11th century. To this period belong two beautiful copies of the *Liber Hymnorum*, containing hymns in Latin and Gaelic composed by the early saints, Patrick, Fiace of Sletty, Columba, and others. The writer of *Leabhar na h-Uidhne*, 'the Book of the Dun Cow,' a miscellaneous compilation extracted from earlier books now lost, was killed in the year 1106. The *Book of Leinster*, a large folio of 410 pages, was written before 1167; the *Book of Ballinacree*, also a large folio of 502 pages, and the *Leabhar Breac*, or 'Speckled Book,' containing 280 pages, by the end of the 14th century. Somewhat later are the *Book of Lecan*, a small folio of over 600 pages; and the *Yellow Book of Lecan*, a large quarto of 500 pages. The number of MSS. increases as we come later down. Mons. H. d'Arbois de Jubainville found 953 in Ireland and England (*Essai d'un Catalogue de la Littérature Épique de l'Irlande*, Paris, 1883), the most valuable of which are in the libraries of the Royal Irish Academy (enriched by the Stowe collection, purchased for the Academy by the government), Trinity College, and Franciscan Monastery, Dublin; in the Bodleian, Oxford; and in the British Museum. Many of these MSS. are beautifully written; while several in the ornamentation of their capitals and margins are fine specimens of the artistic skill of the old Gaelic scribes. The contents are of a very varied description, and embrace all departments of literature. A considerable part is translated or adapted. Such are the portions of the legendary history of Greece and Rome found in Gaelic, the destruction of Troy,

the wandering of Ulysses, the story of the Æneid, the life of Alexander the Great, &c.; most of the passions, homilies, and legends, scriptural and ecclesiastical, in the *Leabhar Breac* and other MSS.; and such also is the medical section of the literature. Of native production are history, including biographies, annals, and genealogies; tales, mythological, heroic, legendary; grammars and dictionaries; law; and poetry.

Modern Gaelic literature can hardly be said to exist. The New Testament was published in 1603, and the Old in 1685. A fresh translation of the Pentateuch was made in 1868 by Archbishop Mac-Hale, who also printed the first six books of the *Hail* and a selection of Moore's melodies in Irish Gaelic. The New Testament has been translated anew by Mr Kane into the Munster dialect. Fugitive pieces of lyric verse have appeared from time to time. The *Reliques of Irish Poetry*, published by Miss Brooke in 1789, and the six volumes published by the Ossianic Society (1854-61), are chiefly 'Ossianic.' 'The Gaelic Union' has printed several texts, and publishes the *Gaelic Journal*.

Celtic scholarship dates from the publication of Zeuss's *Grammatica Celtica* in 1853. Valuable work was, however, done by Eugene O'Curry in his *MS. Materials of Irish History* (1861) and *Manners and Customs of the Ancient Irish* (1873); and by O'Donovan in his *Grammar* (1847), his edition of the *Annals of the Four Masters*, and his *Supplement to O'Reilly's Dictionary*. Zeuss's *Grammatica Celtica* (1853; 2d ed., by Ebel, 1871) was the outcome of thirteen years of unwearied work among old Celtic records. Since Zeuss's day scholarship has advanced over the whole field of Celtic studies, in Old Gaulish and in the Brythonic dialects, but chiefly in Gaelic. Ebel and Schleicher and Ziegfried are worthily represented in our day by such men as Ascoli, Nigra, Windisch, Zimmer, Thurneysen, Jubainville, and Loth on the Continent, and among ourselves by Stokes, Rhys, Atkinson, &c. The *Revue Celtique*, founded in 1870 by Gaidoz, reached its tenth volume in 1890. Several other periodicals at home and abroad, notably Kuhn's *Zeitschrift für Vergleich. Sprachf.*, frequently publish important articles on Celtic subjects. Windisch's *Kurzgefasste Irische Grammatik* has twice been translated into English, in 1879. The same scholar has also published *Irish Texts* for the use of students, with a valuable vocabulary. Zimmer (Berlin, 1881) and Stokes published the valuable Würzburg MS., with minor glosses; Nigra, the Turin glosses; and Ascoli, the St Gall and Milan codices. Copious extracts from the Turin and Milan glosses, together with the Gaelic contents of the *Book of Armagh*, the *Liber Hymnorum*, and the *Book of Deer*, with other early texts, were previously printed by Stokes under the title *Goidelicæ* (2d ed. 1872).

Windisch has examined the laws of *anslaut*, vocalic and nasal, and explained initial aspiration and elipsis (the essay has been translated by the late Dr Cameron, and printed in the *Scottish Celtic Review*). Professors Zimmer and Thurneysen have investigated the position of the accent, and its influence on the development of sound and form in Gaelic. The laws of metre have been discussed by Atkinson, Stokes, and the scholars above named; but, in order to attain to full knowledge of the practice of the bards in this matter, it is necessary that the grammatical tract already referred to as preserved in the *Book of Ballymote* and other MSS. be published. In addition to numerous and valuable papers ranging over the whole field of Celtic studies, Stokes has largely added to our knowledge of the Gaelic noun and verb. Valuable materials for a lexicon have been brought together by Windisch in the *Worterbuch* appended to his *Irische Texte*; by Atkinson

in the vocabularies printed with the Homilies, &c., from the *Leabhar Breac*, and with Keating's *Three Shafts of Death*; by Zimmer in his *Keltische Studien*; and by Stokes in the full *Indices Verborum* attached to the numerous texts published by that great scholar. The life and civilisation of the people have formed the subject of separate treatises, as e.g. O'Curry's *Manners and Customs of the Ancient Irish*, and Rhys's *Celtic Heathendom* (Hilbert Lectures for 1886); but more frequently of elaborate introductions and notes to the more important publications, such as Reeves's *Life of St Columba*; the Master of the Rolls' series; Stokes's *Calendar of Oengus*, *The Tripartite Life of St Patrick*, and *Lives of Saints* from the *Book of Lismore*.

The *National MSS. of Ireland*, edited by Gilbert, have been published by government in the Master of the Rolls' series; as also *The Ancient Laws of Ireland* (5 vols.); *The Annals of Lough Cé* (2 vols. edited by Hennessey); *Chronicon Scotorum* (Hennessey); *The Wars of the Goddial with the Gaill* (Todd); *The Tripartite Life of St Patrick* (Stokes). The Royal Irish Academy has printed in fac-simile *Leabhar na h-Uidhreach* (1870), the *Leabhar Breac* (1876), the *Book of Leinster* (1880), and in photolithography the *Book of Ballymote* (1887); and has published the calendar of Oengus the Culdee, edited by Stokes (1880); *Passions and Homilies from the Leabhar Breac*, with vocabulary, by Atkinson (1887); and Keating's *Three Shafts of Death*, by Atkinson (1890). The Celtic Society published among others the *Book of Rights*, edited by O'Donovan (1845), and the *Battle of Mallow*, edited by O'Curry (1855). The Irish Archaeological Society, which had previously issued several valuable works, as e.g. the *Irish Version of Nennius*, edited by Dr Todd (1848), amalgamated with the Celtic in 1854, and the combined societies have published among other important books the *Liber Hymnorum* (2 vols. Todd, 1855-69); the *Life of Columba*, by Adamnan, edited by Dr Reeves (1856); *Irish Glosses* (Stokes, 1860); the *Topographical Poems of O'Dubhagáin and O'Huidhrú* (O'Donovan, 1862); *The Martyrology of Donegal* (O'Donovan); *Cormac's Glossary* (O'Donovan and Stokes, 1868). The Clarendon Press has issued *Saltair na Rann*, edited by Stokes (1883); the *Battle of Ventry*, by Kuno Meyer (1885); and *Lives of Saints from the Book of Lismore*, by Stokes (1890).

IRISH CHURCH. The Irish Church was a branch of the Celtic Church, which comprehended the churches of Galatia in Asia Minor, of Gaul, and of the original Celtic inhabitants of Great Britain and Ireland. The Celtic Church of Gaul necessarily exercised a great influence over the neighbouring islands. Christianity was introduced from the 2d century at least into Britain, where the Celtic Church was so firmly established that it furnished martyrs in the Diocletian persecution, and bishops to the councils of the 4th century. When the Romans left Britain and the Celts retired into Wales, the Celtic Church retired with them, leaving Britain a prey to Saxon paganism. In Scotland Christianity was introduced in 397 by St Ninian (q.v.), a Scottish Celt, but a disciple of St Martin.

St Patrick is called the apostle of Ireland, and his first missionary arrival is fixed at 432; but there were in all probability scattered colonies of Christians along the eastern coast of Ireland by the year 400. We have proof positive of the existence of Christianity in Ireland in the Chronicle of Prosper of Aquitaine, a contemporary of St Patrick. Prosper, under the date of 431, writes thus: 'Palladius was consecrated by Pope Celestine and sent to the Scots believing in Christ as their first bishop,' where the reader must observe that the name Scots or Scoti was till the 11th century exclusively applied to the inhabitants of Ireland. Palladius had not, however, much success in Ireland; he failed to convince the Irish, was driven northwards, and died in North Britain. Thus ended the first formal attempt to convert the

Irish, an effort made too under the direct sanction and authority of the papal see. The very next year (432) St Patrick is said to have arrived on a similar mission; but he was better qualified for his work, and he made his influence felt in every part of Ireland. Gaul in the early part of the 5th century was the great European centre for eastern monasticism. At the very time that St Patrick landed in Ireland from Gaul there was a most active and continuous intercourse kept up between Gaul and St Jerome at Bethlehem, Nitria, and the monasteries of the Thebaid in Egypt. It is to be expected, then, that the Christianity introduced by St Patrick would exhibit traces of its eastern and especially of its Egyptian origin. The architecture and ecclesiastical arrangements of the early Irish Church have therefore many features in common with the East. The monks of Nitria and of the East were generally solitaries dwelling each in his own cell, even when living in a community and under an abbot. The Irish monks were solitaries too, and down to the present day their beehive huts, constructed so as to secure the least possible comfort for the inhabitants, remain all along the western coast of Ireland. The churches in Ireland are often grouped in sevens and placed within a cashel or stone fortification. So they are in Egypt (Butler, *Coptic Churches*, i. 14). The Irish monks, like the Egyptian, loved solitude and the desert, as the name Desert, Disert, or Dysert, which forms a principal factor in many Irish names, proves. The round towers, too, though not so old as St Patrick's time, came to Ireland from the East through Gaul and Ravenna.

The interval between the arrival of St Patrick and the invasion of Ireland by Strongbow and the Anglo-Normans (1169-72) is a celebrated one in the history of the Irish Church. The 6th and 7th centuries are its best-known epoch, for it was then that St Columba and St Columbanus lived and worked. The Irish Church at that time was the great missionary church of Europe. St Columba was its first great missionary. He was the apostle of the Scottish Highlands, and he summoned to his aid when dealing with the Picts two celebrated Irish saints—Caius the patron of Kilkenny, known in Scotland as Kenneth, and Congall, the founder and first abbot of Bangor in the County Down. St Columbanus (q.v.) preached and taught in Gaul and Burgundy, in Switzerland, and in northern Italy. Other missions were those of Aidan, Colman, Finan, Cedd, and many others in northern and central England; of Virgilius, Marianus Scotus, Cataldus, Fiaccra, Fridolin, and several others in various parts of the Continent, down to the 12th century. All these men were not only great missionaries, but also, viewed by the standard of that day, great scholars. Virgil, the geometer and first bishop of Salzburg, was the first of moderns who taught the doctrine of the earth's sphericity and of the existence of the Antipodes. Columbanus upheld the old eastern cycle against Gaul and Rome combined, Sedulius and John Scotus Erigena knew Greek when a knowledge of it had died out elsewhere in the West.

This ancient church was monastic and yet episcopal. It was episcopal but not diocesan; its highest order were bishops but not prelates. The prelates or rulers were the heads of the monasteries, who might be bishops but were most often mere presbyters and abbots. St Patrick and the early missionaries from Gaul found Ireland intensely tribal. Every modern barony, of which there are some hundreds in Ireland, represents an ancient sept or independent jurisdiction. Every ancient diocese, some thirty or so in number, represents an ancient kingdom, or at least an ancient tribe. The earliest missionaries attached themselves to tribes,

who looked to the monasteries and specially to the first founders of the monasteries, regarding them as the apostles of Ireland. But these missionaries had received Christianity in an episcopal shape, and so they retained it. The abbot exercised jurisdiction over all persons and ranks within his community. But the bishop or bishops who might be resident in the monastery or within its reach exercised episcopal functions, ordaining even the abbots themselves, and celebrating the eucharist in their presence. In the controversy as to the relation towards Rome of the early Irish Church some have insisted that St Patrick was simply a papal emissary. Others have insisted upon his complete independence. There cannot be much doubt, however, that Rome and Ireland were for long divided upon important questions. The controversies of the 7th century with respect to the mode of baptism, the keeping of Easter, and the method of the tonsure prove that, while the Irish Church of that date looked up with the greatest respect to the city where the blessed apostles Peter and Paul had suffered, yet she claimed independence in all matters of doctrine and ritual. The Celtic Church, whether in England, Ireland, or Scotland, made a stubborn resistance to Roman claims. In England and Scotland the resistance collapsed at an earlier period. But in Ireland the ancient national opposition to papal claims did not cease till the Synod of Kells in 1152, and of Cashel in 1172.

As to the ritual of the Celtic Church we have not much information. No ancient service-books have survived in Ireland, though a large number of manuscripts belonging to the Celtic period exist in the Dublin libraries; they are almost all, however, transcripts of the Gospels, as the Book of Kells, or of the New Testament, as in the Book of Armagh. The *Antiphonarium Benchocense* and the Book of Hymns which Dr Todd published in the Irish Archaeological series do not contain the liturgy properly so called—i.e. the service for the Holy Communion. It is most likely, however, that the missal of the Celtic Church was in the main identical with that of the other churches of the West, though there were special local usages most abhorrent to the ideas of the Roman party, till in 1172 the Council of Cashel finally established throughout Ireland conformity with the Church of England. There are two other points connected with the Church of Ireland which have often raised discussions—viz. the round towers and the Culdee system. But Dr Petrie has proved that the round towers are of Christian origin, that they were always connected with monastic establishments, and used partly as bell-towers and partly as places of refuge and defence during the wars of the Danes; while Bishop Reeves has shown that the Culdees (q.v.) were spread all over the Celtic Church, and were only the ancient Celtic monks in a state of corruption.

The Roman system was striving for superiority in Ireland from the 7th till the 12th century. Malachy, Archbishop of Armagh (1134), saw that the ancient Celtic system was hopelessly corrupt. He visited St Bernard of Clairvaux, and could not but be struck by the contrast which his own church presented, devoid of architecture, order, or discipline, the prey of every rude and hostile chieftain, when compared with the Roman system in Gaul, where every rank was duly graduated, every order exercised its due functions, and the laity were humbly submissive to ecclesiastical decrees. St Bernard also about 1140 sent the Cistercians to Ireland, and they became the chief agents in reducing the Irish Church beneath the yoke of canonical obedience. The Cistercians brought notions of material civilisation, especially as regards agriculture and architecture, almost hitherto unknown; for, though the Celtic Church

had cultivated literature and scholarship, the really ancient Celtic churches and monasteries were all of the humblest description so far as their architecture was concerned. Here and there indeed in Ireland, when the Cistercians came, a few specimens of architecture of a highly ornamental type called Hiberno-Romanesque were scattered; but it was the Cistercians who made splendid churches and monasteries fashionable in Ireland. The Cistercian monasteries rapidly spread as Anglo-Norman power advanced all over the island. Ireland within one hundred years after the invasion was more thoroughly conquered than she was three centuries later. The year 1250 saw the king's writ far better respected in Kerry or in Donegal than it was in the reign of Elizabeth, and wherever the Anglo-Norman barons settled they brought the Cistercians with them. De Burgh built St Thomas's Abbey in Dublin in honour of Thomas-a-Becket; De Laey, Bective Abbey, overhanging the Boyne near Navan; Strongbow, the Marshals, and their friends erected Jerpoint and Imbrody in the south; the De Courveys Newry and other abbeys in the north. The Cistercians assisted in other directions as well. The Synod of Cashel met in 1172 under the presidency of Christian, Bishop of Lismore, the papal legate of that day, and passed eight canons, enforced the payment of tithes, regulated the work of catechising and of baptism, established the Roman table of affinity in matrimonial matters, and decreed uniformity of worship throughout England and Ireland. From the date of this synod the canon law, as it was received in England, became law in Ireland. The last Celtic Archbishop of Dublin, Laurence O'Toole, died in 1180. The next archbishop, John Comyn, was an English courtier, nominated by Henry II., and from Laurence O'Toole till the Reformation no Irishman was ever Archbishop of Dublin.

The Anglo-Normans whenever they had power strove completely to exclude the Celts from ecclesiastical benefices, and whenever the Celts had power they strove to exclude the Anglo-Normans. In fact, from 1172 till 1540, there were two churches in Ireland, one Anglo-Norman, the other Celtic, bound together by the one tie, the papal supremacy. This hostility between Celt and Anglo-Norman appears again and again. Prior to 1220 the Anglo-Normans prohibited the admission of Irish clerks into monasteries or benefices under English dominion. The pope rebuked this exclusive spirit in bulls issued in 1220 and 1224. Later in the same century the prelates of the Celtic portion of the church retorted with a decree prohibiting the admission of English clerics into parishes or monasteries under their jurisdiction. This spirit of division was embodied in the Statute of Kilkenny (1365), which peremptorily forbade the admission of Irish clerks into any benefice where English rule prevailed; and it continued to be the practical rule followed in all higher promotions till long after the Reformation. Dublin and Kilkenny were the great seats of Anglo-Norman power from 1172 to 1540. Both these districts are full of monuments of English church building, following exactly the model of coeval English architecture; while one must penetrate far into the mountains of Wicklow, or else depart westward into the great central region of bog and morass, before a glimpse can be had of true Celtic architecture.

While, however, there was this internal national division in the Irish Church during this period, the doctrine, the ritual, and government of the church were uniform. The papal supremacy was universally accepted; the royal supremacy was equally respected. Throughout every part of Ireland, no matter how Celtic, whenever a bishopric fell vacant, license to elect was first humbly sought

from the crown of England. And this was no empty ceremony, for whenever the see was of sufficient value the crown also took good care to signify its pleasure as to who should occupy it. The four archiepiscopal sees, Armagh, Dublin, Cashel, and Tuam, were almost always filled by Anglo-Normans. The Irish Church thus ceased to be a missionary and a learned and became a merely political church.

The national hatred which prevailed between the Anglo-Norman and Celtic portions of the Irish Church between 1172 and 1540 explains the history of the Reformation period. The English portion of the population naturally followed the changes in England, and the Celts as naturally held all the more firmly to the papal supremacy and the old state of things which had now become synonymous with hostility to England. Romanism and nationalism became now and henceforth close allies in Ireland, though previously the pope had been almost always found hostile to the Celts. During the years between 1528 and 1600 the course of change in England was simply reflected in Ireland. Archbishop Alan, an English ecclesiastic who occupied the see of Dublin in 1528, was a friend of Wolsey; and he followed closely his patron's footsteps. About 1528-36 forty of the smaller Irish monasteries were dissolved by him. In 1536-38 the remainder were suppressed and their property granted to the king, who disposed of it to various noblemen and courtiers. In a parliament assembled at Dublin in 1537 the act of the king's supremacy in Ireland was enacted, while in 1542 Henry VIII. was declared king of Ireland, his legal title being previously Dominus Hiberniæ. The work of reformation now advanced *pari passu* in England and Ireland. During the reigns of Mary and Elizabeth the Irish Church, so far as it was under English influence, humbly followed the changes in England; under Mary the papal supremacy was acknowledged, and the Latin mass celebrated; under Elizabeth the royal supremacy was alone legal, and the English liturgy was used. In the Celtic districts during Elizabeth's reign a number of bishops commissioned by Rome, aided by several Jesuits, maintained under great difficulties a vigorous opposition to the Reformation. The 17th century saw new elements of religious confusion introduced. The immigration of the Scottish Presbyterians and the settlement of Ulster brought a community into Ireland who disliked the episcopal establishment almost as much as the pope's adherents. They naturally sympathised with the Puritan opposition in England, which culminated in the supremacy of Cromwell. During his vigorous rule, which secured for Ireland a greater amount of peace than she had long known, the episcopal establishment was subverted, and an establishment of a congregational type erected in its stead. On the Restoration the episcopal establishment was restored in greater splendour than ever.

The Roman Catholics now began to consolidate their organisation, establishing a regular succession of resident bishops and clergy throughout the whole country. After the Revolution of 1688-91 a series of stern enactments commenced, which grew more and more severe till the reign of George II. These penal laws were directed against the Roman Catholics, partly as adherents of the Pretender and partly in revenge for the persecution of the Huguenots (q.v.), many of whom took refuge in Ireland. They began to be relaxed during the earlier half of the reign of George III. In fact all through his reign the Roman Catholic Church exercised openly all its functions and maintained a regular episcopal succession. In 1829 the act of Catholic Emancipation (q.v.) was passed, which swept away

all disabilities affecting the secular clergy of the Church of Rome, though still retaining certain restrictions upon the regular orders. By the act of Disestablishment, passed 26th July 1869, the state has separated itself as far as possible from interference in the affairs of any branch of Irish Christianity. The former Established Church is now governed by a general synod, which meets annually in spring, composed of the bishops and representatives of the clergy and laity; while the Roman Catholic Church is ruled, as formerly, by the bishops acting under the direction of the pope. Irish Presbyterianism, dating from 1613, prevails especially in the eastern parts of Ulster. The Presbyterians of Ulster were till 1869 endowed with a *Regium Donum* (q.v.). The organisation of the Presbyterian Church dates from 10th June 1642, when the first presbytery was established in Carrickfergus.

See, among older authorities, Ussher's Works; Sir James Ware's Works (ed. Harris); Colgan's *Acta Sanctorum Hib.*; *Annals of Four Masters*, and works in Roll-series, as *Chronicon Scotorum* and *Annals of Lough C.*. In the 19th century, Todd in his *Life of St Patrick*, and R. King in his *History of the Irish Church*, maintain the Protestant view; Cardinal Moran, in *Essays on the Early Irish Church*, the opposite view; Lauigan, in his *Ecclsiastical History of Ireland*, an intermediate position. Dr Reeves in his *Abbot's Life of Columba* and other works has thrown floods of light on the subject. Other authorities are E. Hogan, S.J., *Documenta de S. Patricio*; Whitley Stokes, *The Tripartite Life of St Patrick*; Warren, *Celtic Liturgy*; Skene, *Celtic Scotland*. G. T. Stokes in *Ireland and the Celtic Church* (1886), and *Ireland and the Anglo-Norman Church* (1889), maintains the independence of the Irish Church; Canon Bellesheim in his works on the history of the Catholic Church in Scotland (1888) and in Ireland (1890) defends the opposite view. See also Bishop Healy of Clonfert, *Schools and Colleges of Ancient Ireland* (1890); Wasserschleben, *Die Irische Kanonensammlung* (1885); Olden, *The Holy Scriptures in Ireland One Thousand Years Ago* (1888); T. K. Abbott, *Versio Ante-Hieronymiana*; Gilbert, *Facsimiles of the National MSS. of Ireland*. For the more recent history: Mant, *History of the Church of I.*; J. T. Ball, *History of the Reformed Church in I.*; Hogan, *Hib. Ignatiana*; Reid, *History of the Presbyterian Church in I.*; Cotton, *Fæsti Eccl. Hibern.*; D'Alton, *Archbishops of Dublin*; Irwin, *Irish Presbyterianism* (Lond. 1890).

Ireland. SAMUEL WILLIAM HENRY, the author of the notorious Shakespeare forgeries, was born in London in 1777, the son of Samuel Ireland, a dull and credulous, but honest dealer in old books and prints, and author of a few books of travel illustrated by himself. After some years' schooling in France, the boy was apprenticed at seventeen to a London conveyancer, and ere long was tempted by his father's unintelligent enthusiasm for Shakespeare to forge an autograph of the poet on a carefully-copied old lease. His audacity grew with the growing credulity of his dupes, and ere long locks of hair, private letters, annotated books, &c. were plentifully produced, and all inquirers into the how and the where fibbed off with lying explanations. Boswell, Wharton, Dr Parr, and hundreds more came, saw, and believed; but those, like Malone, really qualified to judge denounced the imposture almost from the first. Ireland's audacity now reached the folly of producing a deed of Shakespeare's bequeathing his books and papers to a William-Henry Ireland, an assumed ancestor. Next a new historical play entitled *Fortiperna* was announced, and carefully concealed until its production by Sheridan at Drury Lane. It was vapid, worthless, and un-Shakespearean, and was hopelessly damned at once, and this fate nipped in the bud the growth of a projected series of historical plays, of which indeed that on Henry II. had already been written. The meanness of the impudent young scoundrel's father at length getting the better of his credulity, he demanded from his son a satis-

factory explanation of the source of the papers, and the young man was forced to confess his villany. He published his confession in a tract in 1796, and more fully in his *Confessions* in 1805. The father's death in 1800 was supposed to have been hastened by his shame, and the son soon sank into obscure poverty, eking out a miserable living as a bookseller's hack, till his death on 17th April 1835.

Ireland Island, one of the Bermudas (q.v.).

Irenæus, one of the most important of the ante-Nicene Christian writers, was probably born near Smyrna, in Asia Minor, between 120 and 140, and in his early youth was acquainted with Polycarp; but he is known in history solely through his connection with the Græco-Gaulish Church of southern France, of which he was a bishop. He was a priest of the church of Lyons, under the Bishop Pothinus, upon whose martyrdom, in the persecution of Marcus Aurelius, in 177, he was himself elected to the same see, which he continued to govern for twenty-five years. Gregory of Tours states that he suffered martyrdom in the persecution under Severus in 202; but this is probably a mistake. His day is the 28th of June. Irenæus was a devoted and successful missionary bishop, but his name is associated chiefly with his activity in opposing the Gnostics, and especially the Valentinians, and with his attempts to prevent a rupture between the Eastern and Western Churches over the question of the day on which Easter was to be kept. The only work of his which has come down to us, except a few fragments, is his treatise *Against Heresies*; and even that, except parts of the first book which are preserved in quotations in Hippolytus and Epiphanius, we have only in a barbarous Latin version. It is in five books, the first two describing and criticising the tenets of various sects, Gnostic and Ebionite, the last three setting forth the orthodox Christian belief. The first edition of this work was published by Erasmus (1526), from three MSS. which have since been lost. The best editions are those of Stieren (Leip. 2 vols. 1851-53) and Harvey (Camb. 1857). There is a translation, including the fragments, in Clark's *Ante-Nicene Library*. An able examination of Irenæus' opinions will be found in Dr Werner's *Der Paulinismus des Irenæus* (1890).

Irene, a poor orphan girl of Athens (born about 752), whose beauty and talents excited the admiration of the Emperor Leo IV., who married her in 769. After the death of Leo in 780 she ruled as regent during the minority of her son, Constantine VI. Banished to Lesbos in 802, she died there the next year. The Greek Church, on account of her zeal for image-worship, counts her among its saints. See BYZANTINE EMPIRE.

Ireton, HENRY, an English general of the period of the Commonwealth, was the eldest son of Gorman Ireton, of Attenborough, Nottingham, and was born in 1611. He studied at Oxford and at the Middle Temple, London, and on the breaking out of the Civil War offered his services to the parliament. His connection with Cromwell, whose daughter Bridget he married in 1646, greatly advanced his interests. At Naseby he was taken prisoner by Rupert, but Cromwell's charge set him at liberty. Ireton was one of the most implacable enemies of the king, and signed the warrant for his execution. He accompanied Cromwell to Ireland, and in 1650 became lord deputy. On 26th November 1651 he died of the plague before the walls of Limerick. From Westminster Abbey his remains were transferred at the Restoration to Tyburn.

Irideæ, or IRIDACEÆ, a natural order of endogenous plants, mostly herbaceous, with bulbous, tuberous, or creeping root-stocks; a few are some-

what shrubby. The leaves are generally sword-shaped, in two rows, and *equitant* (so placed that one seems to ride on the back of another). The perianth is 6 partite, coloured, often very beautiful, in some regular, in others irregular. The stamens are three, with anthers turned outwards. The ovary is inferior; there is one style, with three stigmas, which are often petal-like, and add much to the beauty of the flower. The fruit is a 3-celled, 3-valved capsule. About 700 species are known, of which the greater number are natives of warm countries. They are particularly abundant in South Africa. A few are British. Iris, Gladiolus, and Crocus are familiar examples of the order. Acridity is a prevailing characteristic, and some species are medicinal; but the roots and root-stocks of some are edible.

Iridescence, the sheen of mother-of-pearl and other objects possessing a finely-grooved surface. It is due to Interference (q.v.) between the waves of white light reflected from different levels in the grooving; some of the wave-lengths are more completely abolished by interference than others are; the result is that the residual vibration which reaches the eye contains a preponderant proportion of the rays which have been less affected by interference, and the reflected light accordingly presents colours which vary according to the angle of reflection.

Iridium (sym. Ir, atomic weight 192.5—sp. gr. 22.38) is one of the so-called noble metals. It is occasionally found native and nearly pure in considerable masses among the Uralian ores of platinum, but is usually combined with osmium as an alloy in flat scales. It is a very hard, white, brittle metal, which may be melted by the oxyhydrogen blowpipe, or by the heat of a voltaic current. It is malleable at a white heat. In its isolated form it is unacted upon by any acid, or by aqua regia, but as an alloy it dissolves in the latter fluid. It forms two oxides, Ir_2O_3 and IrO_2 , and three series of salts distinguishable by their colours, usually much less soluble than the corresponding platinum compounds. Three sulphides and chlorides are obtainable. Iridium may be fused with phosphorus, becoming as hard as before, and is used for pen points, contact points in telegraphy, and wearing parts of scientific instruments. Iridium was discovered by Descotils and by Tennant in 1803.

Iris (originally a personification of the rainbow), the messenger of the gods in the *Hind*, an office which belongs to Hermes in the *Odyssey*, was daughter of Thaumas and Elektra, and sister of the Harpies. In the earlier poets she is a virgin goddess, but later writers make her wife of Zephyrus, and mother of Eros. She is frequently represented on vases and in bas-reliefs as a youthful winged virgin, dressed in a long tunic, with a herald's staff and a pitcher in her hands. The broad coloured ring in the eye is called the Iris (see EYE). Iris is also the name of one of the Planetoids (q.v.), discovered in 1847.

Iris, or FLOWER-DE-LUCE, a numerous genus of plants of the natural order Iridaceæ, having the three outer segments of the perianth reflexed, the three inner arched inwards, and three petal-like stigmas covering the stamens. The species are widely spread over the northern hemisphere. The Yellow Iris or Corn Flag (*I. pseudacorus*) is abundant throughout Britain, and is readily distinguished from the Stinking Iris (*I. foetidissima*) by its larger and bright yellow flowers. The latter has violet-blue or rarely pale yellowish-white flowers, and the leaves smell disagreeably when bruised. The flowers of most of the species are beautiful. Some of them have received much attention from florists, particularly *I. siphnioides*, sometimes called Spanish

Iris; *I. siphnioides* or English Iris; and *I. germanica* or Common Iris, all European species.



Yellow Iris (*Iris pseudacorus*):
a, seeds.

Many fine varieties have been produced. The Persian Iris (*I. persica*), the Snake's-head Iris (*I. tuberosa*), and the Chalcidonian Iris (*I. sasiama*) are also much esteemed. The Persian Iris is delightfully fragrant. The roots of all these species are annually exported in considerable quantities from Holland. Many other species are of frequent occurrence in flower-gardens.—The fresh root-stocks of *I. pseudacorus* are very acrid, as are those of many other species. Those of *I. florentina*, *I. pallida*, and *I. germanica* are Orris Root (q.v.). Those of *I. dichotoma* are eaten in Siberia; those of *I. edulis* at the Cape of Good Hope.

Irish Elk. See ELK.

Irish Moss. See CARRAGEEN.

Irish Sea, a body of water lying between the north of Ireland and the north of England, with the south-western counties of Scotland on the north. It is connected with the Atlantic on the north-west by the North Channel and on the south by St George's Channel. Between the coasts of Louth (Ireland) and Lancaster the Irish Sea has a width of 150 miles; its greatest length north and south is about the same. Within its boundaries lie the Isle of Man and Anglesey, with Holyhead Island.

Iritis is the term applied to inflammation of the iris. See EYE.

Irkutsk, a government of eastern Siberia, separated from China on the S. by the Sayan Mountains, from Transbaikalia on the E. by Lake Baikal, and bounded W. by Yeniseisk, and N. and N.E. by Yakutsk, occupies an area of 287,061 sq. m. The country is generally mountainous, but produces rye, barley, oats, and vegetables. The most important river is the Angara or Upper Tunguzka (1000 miles), which connects Lake Baikal with the river Yenisei. The Lena and its tributary the Vitim are the rivers that come next in size. Gold, iron, and salt figure foremost amongst the mineral products. Agriculture, cattle-breeding, and the transport of goods to and from China are the chief occupations of the people. The pop. 501,237 in 1897, consists of Burjats, Tungus, and Russians (one-third exiles and forced colonists). The industries are not much developed, consisting

chiefly of brandy-distilleries, with iron-foundries and factories for salt, cloth, and pottery. The towns are Irkutsk, Kirensk on the Lena, Nijnindinsk, and Verkholensk.

IRKUTSK, the capital, on the Angara, is the residence of the governor-general of eastern Siberia and the seat of a bishop. Although 3722 miles from St Petersburg (and 40 from Lake Baikal), Irkutsk is the best-built town in Siberia, with straight, wide streets, and handsome public buildings. It possesses a cathedral, several churches, a public library, a museum of natural history, and other public institutions. The pop., 32,512 in 1875, had increased to 43,962 in 1886; it consists mostly of Russians and Buriats. Irkutsk was founded by a Cossack chief, Ivan Pochobof, in 1652, and obtained town rights in 1686. Owing to its position on the great Siberian highway between China and Russia, it is the commercial centre of Siberia, especially for the tea-trade; the annual value of its trade amounts to about £1,100,000. The Angara constitutes the main highway for goods bound for Kiachta across Lake Baikal, as well as for those coming from eastern Siberia and China for Russia. The communications between Irkutsk and Yakutsk and the northern parts of Siberia are carried on by the river Lena. Irkutsk is an important station on the great transcontinental Siberian railway. A fire in 1879 did damage to the extent of £2,000,000.

Irmin and Irmin Pillars. Irmin was a god of the ancient Germanic tribes, the Hermiones and the Hermunduses. To him were dedicated the so-called Irmin or Irmin Pillars, one of which originally stood at Marsberg in Westphalia, but was destroyed by Charlemagne in 772. These pillars were mostly made of wood, and probably were crowned with an image of the god. They were held in great veneration by the people. 'Irmin's chariot' was a name given to the constellation of the Great Bear.

Itrnerius, the 'Lucerna Juris,' a learned jurist of the 12th century, who was born in Bologna, flourished there as a teacher of the liberal arts, and died under the Emperor Lothair II. before 1140. One of the earliest to devote serious study to the *Institutes* and *Code* of Justinian, he has been (some think without reason) regarded as the founder of the Bolognese school of law. We possess by him some unprinted Glosses, and the so-called *Authentica*, an epitome of the *Novells* of Justinian. His *Forumbarium Tabelliarum*, a directory for notaries, and his *Questiones* are not now extant. His name also occurs in the forms Guarnerius, Warnerius, &c. See the monograph by Vecchio (Pisa, 1869), and the 3d vol. of Ficker's *Forschung. zur Reichs-u. Rechtsgesch. Italiens* (hmsbr. 1870).

Iron, sym. Fe (*ferrum*), atomic weight 56, sp. gr. 7.8 to 7.9; its density being increased by hammering, rolling, &c. *Pure iron* is a chemical curiosity obtainable in the laboratory by reducing pure oxide by charcoal or hydrogen at a very high temperature. A button of the metal thus obtained is white and of perfect lustre, very tough, and much softer than ordinary iron. Its melting-point is higher, so much so that if we attempt to fuse it when exposed to the air it burns before its melting-point is attained.

Ordinary commercial iron is protected from such combustion by the impurities it contains; these being more readily oxidised than the iron itself, while they lower its fusing-point. Carbon, silicon, sulphur, and phosphorus are the most notable of these impurities, but manganese, titanium, calcium, copper, arsenic, and other metals also occur in minute quantities in some samples. The proportions of all these are largest in crude or 'pig' iron, and in ordinary cast iron. They are reduced to a

minimum in wrought or malleable iron. The colour of this is gray or bluish-white; it is hard and lustrous, takes a high polish, is fibrous in texture, and when broken across exhibits a ragged fracture. It requires a very intense heat for its fusion, but before melting passes into a soft, pasty condition, in which state two or more pieces of iron may, by being hammered together, be united or welded so completely as to form, to all intents and purposes, a single piece. At a red heat it may be readily forged into any shape; but at ordinary temperatures it possesses very little malleability, as compared with gold and silver. In ductility it stands very high, being barely exceeded by gold, silver, and platinum; and its tenacity is very great; when combined with a little carbon it stands at the head of all the metals (see STEEL). Its susceptibility to magnetism is one of its remarkable characteristics (see MAGNETISM). At a high temperature it burns readily, as may be seen at the forge, or (more strikingly) when a glowing wire is introduced into a jar of oxygen. In dry air and at ordinary temperatures the lustrous surface of the metal remains unchanged; but in a moist atmosphere the surface rapidly becomes oxidised and covered with rust, which consists mainly of the hydrated peroxide of iron. At a bright red heat iron combines with the oxygen of steam and liberates hydrogen.

Native iron is a rare mineral, found in small grains in some basaltic rocks, and very rarely as thin veins. It occurs as one of the chief constituents of one class of meteoric stones. Its compounds are very widely distributed, more so than any other of the heavy metals. Nearly all of the sedimentary rocks are tinted by its oxides, and we cannot find a handful of soil on any part of the surface of the earth that is free from them.

(a) *Oxides of Iron.*—Iron forms four definite compounds with oxygen—viz. (1) the *protoxide* or *ferrous oxide*, FeO, which is the base of the green or ferrous salts of iron; (2) the *sesquioxide* or *peroxide* or *ferric oxide*, Fe₂O₃, which is the base of the red or ferric salts; (3) the *black* or *magnetic oxide*, Fe₃O₄, which is regarded as a compound of the two preceding oxides; and (4) a questionable compound, *ferric acid*, FeO₃. The *protoxide* cannot be obtained in an isolated state, but it forms the base of various ferrous salts, and combines with water to form a hydrate, FeO.H₂O, which, on the addition of an alkali, falls in white flakes provided the water in which they are suspended contains no free oxygen; otherwise the precipitate is gray.

The most important protosalts of iron, or ferrous salts, are the carbonate, the sulphate, the phosphate, and the silicate. *Carbonate of iron* or *ferrous carbonate*, FeO.CO₂, exists naturally in various minerals, and may be obtained artificially by precipitating a soluble protosalt of iron with carbonate of potash or soda, when the carbonate falls in white flakes. On exposure to the air it absorbs oxygen and gives off carbonic acid, and is thus converted into the hydrated peroxide. *Sulphate of iron* or *ferrous sulphate*, FeO.SO₄.7H₂O (or FeSO₄.7H₂O), is obtained by the solution of iron, or its sulphide, in dilute sulphuric acid; in the former case there is an evolution of hydrogen, and in the latter of sulphuretted hydrogen. On evaporation of the solution the salt is obtained in clear, bluish-green rhomboidal crystals containing seven atoms of water. This salt is commercially known as copperas or green vitriol. *Phosphate of iron* is obtained by precipitating a solution of a protosalt of iron with phosphate of soda, when a white precipitate of phosphate of iron is thrown down. All these salts, especially the carbonate and sulphate, are extensively used in

medicine. *Silicate* and phosphate of iron occur naturally in many minerals.

The *peroxide of iron*, or sesquioxide, Fe_2O_3 , is obtained in an anhydrous form by igniting the protosulphate, and is known in the arts under the names *Cochin*, *Crocus of Mars*, or *Rouge*, according to the degree of levigation to which it has been submitted. It is employed for polishing glass, jewellery, &c., and is also used as a pigment. It occurs both in the anhydrous and in the hydrated form in various minerals. The hydrated peroxide, $2\text{Fe}_2\text{O}_3 \cdot 3\text{H}_2\text{O}$, is obtained by precipitating a solution of a persalt of iron with an excess of potash, ammonia, or alkaline carbonate. It falls as a yellowish-brown flocculent precipitate, which when dried forms a dense brown mass. Rust, as has been already mentioned, is a hydrated peroxide.

The most important of the persalts of iron, or ferric salts, are the neutral and the basic sulphate, whose formulæ are $\text{Fe}_2\text{O}_3 \cdot 3\text{SO}_4$ and $\text{Fe}_2\text{O}_3 \cdot 3\text{SO}_3 \cdot 5\text{Fe}_2\text{O}_3$ respectively, the nitrate, $\text{Fe}_2\text{O}_3 \cdot 3\text{NO}_3$, the phosphate, and the silicate. Of these the neutral sulphate, the phosphate, and the silicate occur in various minerals. The nitrate, which is obtained by the solution of iron in nitric acid, is a useful medicinal agent.

The *black* or *magnetic oxide* is formed when iron is heated in air or in oxygen, or in vapour of water.

(b) *Haloid salts of iron*—the chlorides, bromides, and iodides. There are two chlorides—viz. a protochloride, FeCl_2 , and a perchloride or sesquichloride, FeCl_3 . The latter may be obtained by dissolving peroxide of iron in hydrochloric acid. The tincture of the sesquichloride of iron is much employed in medicine. The protiodide is an extremely valuable therapeutic agent.

(c) There are several *sulphides* or *sulphurets of iron*. The protosulphide, FeS , occurs in small quantity in meteoric iron. It may be obtained artificially by heating iron with sulphur. It is a blackish, brittle substance, retaining in some degree the magnetic properties of metallic iron. It is insoluble in water, but in moist air becomes oxidised into protosulphate of iron. With acids it develops sulphuretted hydrogen. The bisulphide of iron, FeS_2 , is the *iron pyrites* of mineralogists, and the *mundic* of commerce. Under the latter name it is used extensively in the preparation of oil of vitriol. The other sulphides are of less importance.

The *protosalts* and the *persalts*, or the *ferrous* and the *ferric salts*, give totally different reactions with the ordinary tests. The solutions of the former have a pale green colour, while those of the latter are generally of a brownish-yellow colour. Sulphuretted hydrogen gives no precipitate with an acid solution of a ferrous salt, while it gives a milky precipitate of sulphur with a solution of a ferric salt. Potash, soda, and ammonia throw down a gray or green hydrated oxide from the former, which changes to darker green and brown, and a brown hydrated peroxide from the latter. Ferrocyanide of potassium gives with ferrous salts a white precipitate, which soon becomes blue, while with ferric salts it at once produces a blue precipitate, even in a very dilute solution. Tincture of galls (tannic acid) produces no immediate change of colour with the ferrous, but a deep blackish-blue colour (ink) with the ferric salts. Sulphocyanide of potassium produces no change with the ferrous, but gives a deep blood-red tint with the ferric salts. Succinate and benzoate of ammonia produce no precipitate or change of colour with the former, while with the latter, if the solution is not too acid, they throw down pale reddish-brown precipitates.

MANUFACTURE OF IRON.—The increasing use of

iron is a prominent characteristic of the present age, and every day sees some new application of it in the arts of life. Although the most useful of the metals, it was not the first known. The difficulty of reducing it from its ores would naturally make it a later acquisition than gold, silver, and copper (see BRONZE). The reduction of the ore known as the black oxide of iron, however, has been carried on in India from a very early time.

In Europe the rich specular and other ores of Spain and Elba were much used during the Roman period; in Greece, also, iron was known, though, as among the Romans, its use was subsequent to that of bronze. We are informed, too, by the Roman historians that this metal was employed by the ancient Britons for the manufacture of spears and lances. The Romans, during their occupation of Britain, manufactured iron to a considerable extent, as is shown by the cinder-heaps in the Forest of Dean and other places. The rude processes then in use left so much iron in the cinders that those of Dean Forest furnished the chief supply of ore to twenty furnaces for between 200 and 300 years. In those early times the iron ores were reduced in a simple conical furnace, called an *air-bloomery*, erected on the top of a hill in order to obtain the greatest blast of wind. The furnaces were subsequently enlarged, and supplied with an artificial blast. Charcoal was the only fuel used in smelting till 1618, when Dud Dudley introduced coal for this purpose; but, the iron-masters being unanimously opposed to the change, Dudley's improvement died with himself. It was not reintroduced till Abraham Darby, in 1713, employed it in his furnace at Coalbrookdale. But, as this method was not properly understood, the production of English iron declined with the change of fuel, till, in 1740, it was only three-fourths of what it had formerly been. About ten years after this, however, the introduction of coke gave renewed vigour to the iron-trade, and then followed in rapid succession those great improvements in the manufacture which have given to the history of iron the interest of a romance. The introduction of Watt's steam-engine in 1770, the process of puddling and rolling invented by Henry Cort in 1784, and the employment of the hot-blast by Neilson of Glasgow in 1830 have each been of inestimable service. The greatest improvement introduced into the iron manufacture in recent times is the process of Sir Henry Bessemer for the production of mild steel, patented in 1856 (see BESSEMER). The 'Siemens-Martin' method of making steel has also of late come into extensive use.

Iron ores are abundantly distributed over the globe, the chief kinds being (1) magnetic iron ore; (2) red hematite, specular, or red iron ore; (3) brown hematite or brown iron ore; (4) carbonate of iron, including spathic ore, clay ironstone, and blackband ironstone.

The ore richest in the metal is the *magnetic* or *black oxide of iron*. When pure it contains nothing but oxygen and iron, its chemical formula being Fe_3O_4 , which gives 73 per cent. of iron by weight. It occurs in dark heavy masses or black crystals, and is found in the older primary rocks. Sweden is famous for this ore, and for the iron produced from it, which is esteemed the best in Europe. The celebrated mines of Dannemora, in that country, have been constantly worked since the 15th century. Russia, too, has great iron-works in the Ural Mountains, which are supplied with this ore. So also have Canada and several of the American states, as Virginia, Pennsylvania, New Jersey, &c. The rock formations in which magnetic iron ore occurs very rarely contain coal; hence it is locally smelted with wood charcoal, which contains no sulphur.

Red hematite contains a little more oxygen, its formula being Fe_2O_3 , that is to say, 70 per cent. of iron by weight if pure. The best ores actually contain from 60 to 67 per cent. There are several varieties of this ore. The first of these, *specular iron*, so called from its bright metallic lustre, occurs in large and beautiful crystalline masses in the island of Elba, where it has been worked for more than 2000 years, and is likewise found in many other parts of the world. It is of a steel-gray colour, assuming a red tint in thin fragments and when scratched. Another variety is *kidney ore*. Its characteristic form is in large kidney-shaped nodules, with a fine radiated structure. Red hematite is the most abundant variety. It occurs in massive deposits and in thin strata; some specimens are hard, others pulverulent and so soft that when rubbed it coats the fingers with an unctuous smear like plumbago, but of red colour. Its importance has much increased of late owing to its special fitness for making the pig-iron used in the ordinary Bessemer process. This valuable iron ore is found in great abundance at Whitehaven and Ulverstone, in the north-west of England, where splendid masses of it occur, 15, 30, and even 60 feet in thickness. Vast deposits are found in the north of Spain near Bilbao, where it is now largely worked and exported to Great Britain, which in 1890-95 received annually from 2,500,000 to 3,500,000 tons, worth from £2,000,000 to £2,500,000.

Brown hematite, or brown iron ore, is a hydrated peroxide of iron, and has the same composition as red hematite, except that it contains about 14 per cent. of water. It is generally found massive, more rarely crystalline, and a variety occurring in small rounded nodules is called *pea iron ore*. When mixed with earth or clay it forms the pigments yellow ochre and brown umber. Brown hematite is now an important ore in Great Britain. It occurs in different geological formations, chiefly in Devonshire, the Forest of Dean, South Wales, and in the county of Antrim in Ireland; also in an earthy form in Northamptonshire. It is the ore chiefly smelted in France and Germany.

Bog iron ore is an impure variety of brown hematite usually containing phosphorus. It occurs in curious pockets in peat.

Humite is a dark-gray dense rock composed largely of peroxide of iron with varying quantities of titanate acid. It is found abundantly in Norway, and is now in practical use. The black sand found on the north-east shores of Canada, and at Taranaki, New Zealand, is similar, but the oxide of iron is magnetic.

Carbonate of iron, when found in a comparatively pure and crystallised state, is known as *spathic*, *spathose*, or *sparry iron ore*; but when impure and earthy, as *clay ironstone* and *blackband ironstone*. Spathic ore was little worked in England previous to 1851, soon after which it was discovered in Somersetshire. The Erzberg, near Eisenerz, in Styria, is the most famous locality for this ore, where it has been worked for ages. The spathic carbonates which are the richest in manganese have been much in demand to yield the spiegeleisen required in the Bessemer process. In its purest form it contains 48 per cent. of iron; and in colour it varies from white to buff or dark brown, some specimens of it taking a beautiful polish, and looking like marble. The clay and blackband ironstones are essentially mixtures of carbonate of iron with clay, blackband having also a considerable proportion of coaly or bituminous matter. These dull earthy-looking ores occur abundantly in Great Britain. Until lately above one-third of all the ore mined in the country was obtained from the coal-measures, where fortunately both the fuel and the limestone, indispensable for the reduction of

the iron, are also found. The ore occurs as balls or nodules, or in continuous beds.

The following table shows how widely distributed are British ironstones. The last item of English production is especially significant. It represents the poorest and worst of all the workable ores, but, being so easily obtained (mostly in open workings like stone quarries), is very cheap, and, being also near to abundance of coal, is used in the great quantities there stated. It is indeed merely an indurated ferruginous mud containing from 40 down to only 20 per cent. of iron.

PRODUCTION OF IRONSTONE FROM MINES UNDER THE COAL-MINES REGULATION ACT.

Counties.	1887.		1888.	
	Tons.	Average Price per Ton.	Tons.	Average Price per Ton.
Brecon	366	s. 4 7 0	605	s. 4 7 0
Cardiff	36	7 0	243	7 0
Cumberland	1,037	6 0	761	6 0
Denbigh	2,713	7 0	651	7 0
Derby	5,799	6 2	11,823	6 0
Glamorgan	22,472	8 0	22,753	7 0
Lincoln	78,047	3 0	44,187	3 0
Monmouth	22,139	7 9	18,863	7 9
Nottingham	121	6 0	750	6 0
Shropshire	100,600	5 0	131,100	5 0
North Staffordshire	480,400	5 0	1,629,277	5 0
South Staffordshire	97,618	8 1	60,491	10 7
Warwick	1,838	7 4	4,230	8 0
Worcester	12,544	8 1	7,571	10 7
Yorkshire (E. & W.)	81,868	10 9	67,148	10 0
Yorkshire (North R.)	4,980,431	2 11	3,395,942	2 11
Total, England	6,248,019	7,396,365
Ayrshire	607,697	8 0	557,309	8 0
Dumfries	115,399	8 0	99,889	8 0
Edinburgh	79,791	9 0	66,127	9 0
Fife	2,980	9 0	2,846	9 0
Haddington	179	9 0	75	9 0
East Lanark	162,066	9 0	128,532	9 0
West Lanark	112,806	8 6	55,186	8 6
Midlothian	75,798	9 0	95,866	9 0
Perthshire	3,177	9 0	16,354	9 0
Renfrew	153,892	8 0	179,833	8 0
Strathclyde	8,128	9 0	36,580	9 0
Total, Scotland	1,321,899	1,238,597
Grand Total—United Kingdom	7,569,918	8,635,032

Including the ores mined under the Metalliferous Mines Act—ores not directly associated with coal—the iron ore raised in 1878 was 15,726,370 tons. In 1894 it was 12,367,308 tons, valued at £3,190,647; the metal produced was 4,317,472 tons, value £9,999,186. In the United States the production of ore was 7,120,362 (long) tons; in 1889, 14,518,041; while in 1894, the produce of pig iron was 6,657,388 tons, value \$65,007,247. In Germany, 11,406,100 tons of iron ore were raised in 1890, and 12,403,800 in 1894. In 1893, France raised 3,517,438 tons of iron ore; Austria-Hungary, 1,100,000 tons; while Russia produced 1,272,235 tons of pig iron.

The ancient iron-masters were unable to work any but the richest and purest ores, the magnetic oxides and hematites. The above table shows by the price and quantity of the North Riding ores that we are now able to work very poor and very impure material.

The most remarkable and useful property of carbon, that upon which its value as a fuel, &c. depends, is that when remaining at ordinary terrestrial temperature it is exceptionally inert, does not combine with the oxygen of the air or even with pure oxygen, nor with other elementary substances (fluorine perhaps excepted), but when heated it acquires so greedy an affinity for oxygen that it not only burns in air i.e. combines

violently with its oxygen (see COMBUSTION), but will take oxygen away from most of its compounds, notably from the metallic oxides. This action of removing oxygen from oxides of metal and leaving the metal in the reguline or metallic state is called reduction, and the great reducing agent of the metallurgist is heated carbon. Hydrogen acts in a similar manner, and is also used as a reducing agent.

The ancient iron-masters obtained iron and steel by simply heating the purest obtainable oxides of iron with an easily-prepared and nearly pure form of carbon—viz. wood-charcoal. Their furnaces

were of very simple construction, merely a hearth or fireplace in which the ore and the charcoal were mixed together and a blast applied to obtain the necessary high temperature. Such simple iron-making is still practised in India, Burma, Borneo, China, Madagascar, &c., and very fine qualities of iron and steel are thus produced.

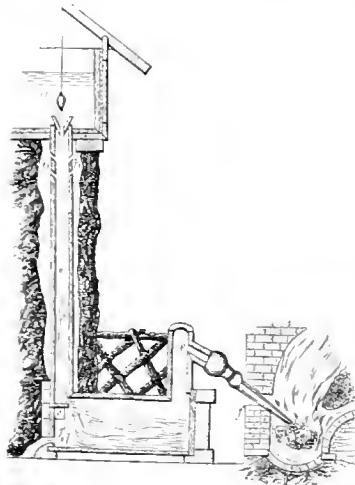

Fig. 1.—Catalan or Corsican Furnace.

Space will not permit a detailed description of the various forms of ancient furnaces, but there is one that still survives in Europe which is typical and specially interesting. It is shown in fig. 1, and is known as the 'Catalan' or Corsican furnace. The blowing-apparatus is very curious and effective. *f* is the hearth or furnace with the tuyère or blowing-tube inserted in an opening of the wall. The bottom of the hearth is made of a sandstone that will bear great heat, and is lined with charcoal dust. A pile of rich ore, usually hematite, is placed on this and heaped up over the curved wall opposite the tuyère. The hearth is then filled up with charcoal and covered over with a mixture of charcoal dust and small ore, moistened and matted together. A gentle blast is applied at first, and when the flame bursts through the coating more of the same material is laid over to keep back the main charge until the mass is sufficiently heated for a fair start. Then the blast is turned on fully, and the ore that was piled on the curved wall is pushed down gradually as the lower portion is reduced, and this is continued until a mass of spongy iron, or 'bloom,' is formed. This is drawn out, hammered, and rolled with very primitive machinery. The ancient workers were not acquainted with the use of lime as an artificial flux, and hence the silica of the ore was got rid of by combining with some of the oxide of iron and thus forming a liquid cinder

(see STAG).

The blowing-apparatus or 'trome' shown in

the drawing is used in mountainous countries where streams from high levels are available. The upper tank *a* is erected on a ledge of rock with one end overhanging, in this case supported by a tree-trunk. Connected with the large hole in the bottom is a wooden tube with oblique side openings, *b, b*. This tube terminates at the top of a lower tank *c*, which has an outflow opening at *d*, while its upper part communicates with the tuyère at *e*. The tank is otherwise closed and air-tight. At *a* in the upper tank is a plug to regulate the flow of water into the wooden tube. When water flows down this tube its velocity is of course accelerated as it descends. This acceleration divides the column of water, and the spaces between become more or less vacuous. Consequently air rushes in at *b, b*, is dragged down by the descending water, and cannot return against the stream, but is forced by the rushing water through the narrow passage into the upper part of the lower tank, and there compressed in a degree that admits of regulation by raising or lowering the plug *a*. When the inflow of water is in excess of the outflow, the pressure increases, when the outflow is in excess it diminishes, when they are equal it remains steady, and thus the required variations of blast are regulated.

Modern blast-furnaces are hollow towers ranging from 30 or 40 to nearly 100 feet in height, and with internal capacities varying from 500 cubic feet to upwards of 25,000. The smallest furnaces are those used for smelting the richest and purest ores with charcoal, and, generally speaking, the poorer the ores the larger the furnaces, until we reach the maximum in the Cleveland district of the North Riding of Yorkshire, the metropolis of which is Middlesbrough.

Figs. 2 and 3 show a modern blast-furnace of ordinary dimensions (fig. 2) as seen externally (without its appliances for blast, &c.) and (fig. 3) in section. The external rings are of stout iron, bracing all the masonry together. The interior is lined with firebricks or other refractory material, the thickness of this lining or 'shirt' increasing downwards as the heat increases. Between the shirt and outer brick or stone-work an annular space is usually left which is filled with loose sand or fragments of slag to allow for shrinking or expansion of the interior. The larger furnaces have a double lining with such space surrounding each.

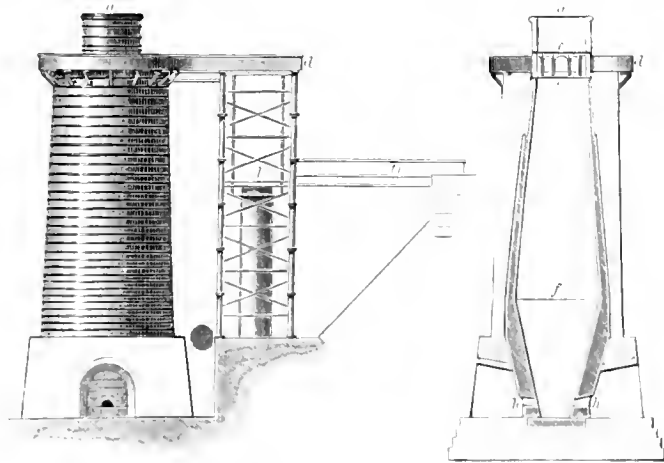

Fig. 2.

Blast Furnace.

Fig. 3.

The internal form is a matter of some practical importance. As shown in the section, the upper part or 'tunnel head,' *a, c*, projecting above the

surrounding gallery, is cylindrical. This part is not added to all furnaces. It merely acts as a chimney. Passing downwards we come to a continuation of this, *c, c*, which is called the 'throat,' the charge being pitched down this from the gallery through the arches or 'tunnels' that are shown in the section. Below this is a long truncated cone, *e, f*, called the 'stack,' extending to the widest part, which is called the 'belly;' this name, another form of the 'hosh' or 'hoshes' (supposed to be a corruption of the German *bauch*), is applied to the lower inverted cone, which extends from *f* to *h, h*, where the blast enters by the tuyères or tuyers (from the French *tuyau* or *tuyère*, which is freely translated in the Black Country to 'two irons,' as there are two iron tubes as shown in section, fig. 4,

Fig. 4.

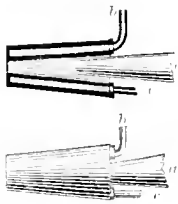
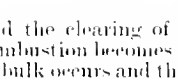

Fig. 5.



and externally, fig. 5). The outer one is surrounded by a lining of flowing water, which enters at *b* and escapes at *c*. This is to save it from fusion. The blast is thrown in through this by the tube *a*. Below these is the crucible where the melted metal rests on the 'hearth.' The charge of ore, fuel, and lime is but slightly altered in bulk until it reaches the hoshes at *f*, and the downward widening therefore assists its descent

and the clearing of the walls; but below this the combustion becomes so active that rapid contraction of bulk occurs and the furnace is shaped accordingly.

The gallery or 'charging-plate,' *e, d*, is shown in fig. 2 connected with a hydraulic lift, by which the charge is raised to the level of the hill-top. In that which is pictured the trolly-road or tramway, *h, h*, is built up to about half height to meet the rising inner tube of the hydraulic lift at *l*. The materials charged into the furnace are ore, fuel, and flux, varying in proportion with the composition of the ore. The demand for flux is due to the impurities of the ore. Lime is used for this purpose. It combines with the silica, and forms a readily fusible compound, a silicate of lime or lime-glass, which descends with the silicate of alumina, an analogous compound in the clay, and forms the 'slag,' or more properly 'cinder,' which floats on top of the fused iron in the crucible. The old iron-masters who used no such flux lost much of their iron by the combination of its oxide with the silica; hence the iron in the 'Dane cinders' of the Forest of Dean. In most of the modern furnaces the crude limestone is charged with the crude ore. Otherwise the ore is first roasted to expel the water of composition it contains (clay is a *hydrated* silicate of alumina) and the carbonic acid which is combined with the iron, and the limestone is similarly roasted in kilns to expel its carbonic acid. In the tall furnaces with hot-blast these operations are automatically performed in the upper part by the heat escaping from below. Formerly the coal was all coked before charging into the furnace; now raw coal or a mixture of coal and coke is used, and the coking, like the roasting, occurs in the upper part of the furnace. As the charge descends to the hotter and hotter parts of the furnace the oxide of iron, now dehydrated and dissociated from carbonic acid, becomes reduced to the condition of 'spongy iron.' The experiments of Sir J. Lowthian Bell show that such reduction occurs at a lower temperature than was formerly supposed. It is fairly started, if not

completed, before the limestone is fully calcined. The chief reducing agent is the heated carbonic oxide gas that rises from the incandescent mass below. This gas, a compound of one equivalent of carbon with one of oxygen, CO, combines greedily with oxygen when heated, and forms carbonic dioxide (carbonic acid), CO₂. In this case it does so by taking away the oxygen from the oxide of iron. The hydrocarbons formed by the distillation of the coal probably co-operate. The spongy iron thus formed corresponds to the final product, the 'bloom' of the Catalan and other primitive furnaces. The iron itself is pure enough, but is entangled with the earthy impurities of the ore. The bulk of these impurities is finally removed by the flux, but before this occurs another and rather vexatious action occurs at the full and bright red-hot region below. This is described by Sir J. L. Bell as the 'zone of absorption,' for here the spongy iron absorbs impurities that have afterwards to be removed by the puddler. It takes up carbon, silicon, sulphur, and phosphorus from its surroundings, the sulphur and carbon from the coal, the silicon and phosphorus from the ore. These, though mischievous, assist the work of the blast-furnace; they lower very considerably the fusing-point of the iron, the pure spongy iron being practically unfusible in an ordinary furnace. The manner in which the spongy iron appears to obtain its carbon is curious. Carbonic oxide when highly heated (2190 F.) is dissociated into carbon and carbonic acid. One half of a given quantity loses its oxygen and gives it over to the other half. Taking two equivalents of carbonic oxide, containing two of carbon and two of oxygen, the change may be represented thus:

$$\begin{array}{c} \text{O} \\ \diagdown \\ \text{C} \longrightarrow \text{CO}_2 \\ \diagup \\ \text{O} \\ \text{C} \longrightarrow \text{C} \end{array}$$

Sir J. Lowthian Bell, who has devoted an immense amount of costly labour to the investigation of the contents of various parts of the blast furnace, maintains that this dissociation occurs at a much lower temperature in the blast-furnace than in Deville's apparatus, possibly owing to the help of the iron in combining with the flocculent carbon immediately it is thus separated.

After these changes are completed, fusion speedily occurs in the rapidly contracting region of the furnace, and finally the whole contents of the furnace, excepting those which are converted into gases that escape from the top, are liquefied and fall into the crucible as two distinct fluids, the melted crude iron, and the cinder or slag. The latter floats above the metal and runs out over a dam by a specially-constructed orifice. While thus covering the iron it protects the metal from oxidation, and this continues until the metal accumulates sufficiently to reach the 'cinder notch' of the dam. When this occurs the furnace is tapped—i.e. a plug which stopped a channel-hole at the bottom of the crucible is removed, and the molten crude iron flows in a glowing stream down long channels in a bed of sand. Side-channels of moderate length branch out on each side of the main channels, as near to each other as possible, and these are filled with the iron. In the poetic language of the Black Country the main channel is called the 'sow,' and the smaller branching channels the 'pigs.' Hence the well-known name of 'pig-iron.'

The table below shows the composition of pig-iron; the first being the mean of twenty-nine brands of high-class pig, the second of a common Cleveland pig; the analyses made by the writer:

Combined Carbon	0.91	0.80
Graphitic Carbon	1.92	1.90
Silicon	1.81	2.23
Phosphorus	0.33	1.50
Sulphur	0.25	0.27
Manganese	1.28	0.71
Iron by difference	93.50	93.60
	100.00	100.00

Pig-irons are technically described as gray, mottled, and white, and commonly numbered accordingly, commencing with the gray as No. 1, down to No. 8, the extreme white. Gray pig-iron is granular and easily drilled or filed, owing to this structure; white pig is crystalline and very hard, harder than the hardest steel. This difference is mainly due to the different conditions of the carbon. In the gray it is nearly all uncombined or graphitic; in the white, nearly or quite all combined; the mottled is intermediate. It is easy to pick out with a penknife from a good sample of No. 1 pig brilliant scales of graphite, technically described as 'kish.' Good samples of pig-iron are used directly for making castings, or the pig-iron is refined (see below) for this purpose. Such 'cast-iron' is brittle in proportion to the impurities it contains. In its ordinary condition it is neither malleable nor ductile, though small castings of a superior quality of refined iron may be rendered tougher by careful annealing. These 'malleable castings' are now largely used.

One of the important improvements of modern ironmaking is the use of the hot-blast. Very great economy of fuel is thereby effected. A great variety of ovens for heating the blast have been patented. Their essential principle is passing the air through tubes or passages of iron or fireclay that are heated by a flame or hot air surrounding them. The heat is usually obtained by utilising the waste inflammable gases that formerly blazed away to waste from the top of the blast-furnace. For this purpose the tunnel-head (*a, c*, figs. 2 and 3) is cut down, or not built, and the charge is thrown upon a stopper, which is movable in such wise as to drop the charge with little or no escape of the gases

from the interior of the furnace. The most common of these devices is the 'cup and cone,' shown in fig. 6, where *u* is the cup that plugs the opening of the truncated cone above. The charge is pitched into this inverted cone and rests there till the cup is

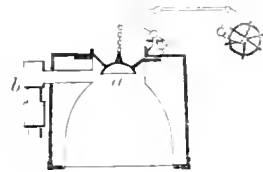

Fig. 6.

lowered, when it falls around the cup. In the figure the furnace is shown closed. The inflammable gases then descend by the pipe *b* to their destination.

In order to obtain ordinary malleable iron from pig iron the bulk of the impurities are removed by 'puddling' and hammering or squeezing. The old iron masters simply melted the crude iron in a refining furnace or 'finery,' and then subjected it to the action of a blast, which sufficiently oxidised the silicon and carbon. Where these are the only impurities that require removal this treatment is still used; but such severe oxidation fails to remove the sulphur and phosphorus. The refining furnace, which is still used to some extent for the conversion of gray into white cast-iron, or as preliminary to puddling, is shown in section in fig. 7. The pig-iron and coke or charcoal are charged into the space *D*; the blast is driven through the blast-pipes, *C, C*, to the tuyeres, as shown. After starting well with fuel below, the coke continues to burn and the iron to melt, and both are continuously charged, the melted iron flowing down to the hearth below, where the blast strikes upon its surface and oxidises the carbon and silicon, at the same time circulating the fluid metal by its stirring action. If this is continued long enough, a bloom or ball of malleable iron is produced. With less blowing the silicon is for the most part burned out, and the graphitic carbon is caused to

combine by the high temperature attained, and thus 'white iron,' suitable for foundry purposes or for puddling, is produced. In this case the melted iron is run into a shallow hearth, and there allowed

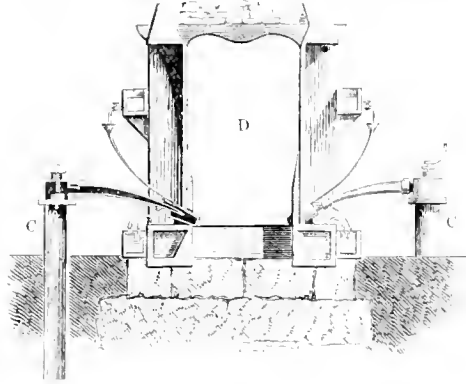

Fig. 7.—Finery.

to cool and throw up a film of silicate, which easily separates from the refined metal below. This is broken up into convenient pieces, and is commonly described as 'plate' iron.

The Bessemer process (see BESSEMER STEEL) is but a modification of this, the difference being that, instead of blowing on the surface, the Bessemer blast is introduced below, and therefore acts more thoroughly.

The puddling furnace, in which the puddling process is conducted, is shown in vertical section in fig. 8, where *f* is the fireplace, *br* the

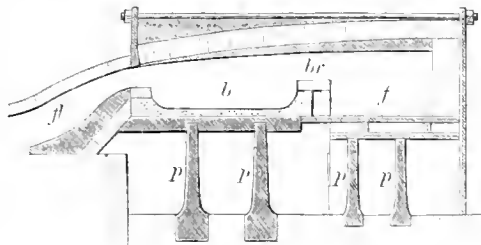

Fig. 8.—Puddling Furnace, vertical section.

bridge, *b* the bed, *fl* the flue, and *p, p, p, p*, iron pillars supporting the furnace. It is constructed of firebricks, and the whole, excepting the flue, is encased in strong iron plates firmly strapped together by iron rods. When the fire is blazing the flame surmounts the bridge, strikes the arched roof, and 'reverberates' down upon the contents of the bed, and passes along the flue to a short chimney, which is surmounted by a damper plate that may be raised and lowered to regulate the draught. Fig. 9 is a horizontal section with the same lettering, excepting that *s* is added to show the working-door or stopper-hole through which the puddler works. When the roof, walls, and bed of the furnace are moderately heated the puddler 'fettles' his furnace by plastering the bed and sides with a 'fettling' composition, which consists essentially of ground oxide of iron made into a paste with water. Hematite is the best fettling; 'bulldog,' made by roasting refuse cinder, is cheaper, and largely used. Lumps of crude iron are now thrown in, the fire is made up, the doors closed, and damper raised to 'rouse' the whole and melt the charge, which usually amounts to 1½ cwt. Two men work the furnace, the 'forehand' and his 'underhand.' During the melting the underhand turns over and

distributes the lumps with a long iron rod. When the melting is completed a heavier iron bar, flattened and bent at the working end, is used. This is called the 'rabble,' and with it a vigorous stirring or 'rabbling' is kept up. The work is very exhausting, and the men work in turns, the forehand taking the critical part of the process, where greater skill is demanded. As this proceeds the surface of the melted metal becomes further agitated by the bursting of small bubbles; this agitation, at first superficial, deepens and deepens, until the whole mass is seen to be violently seething and

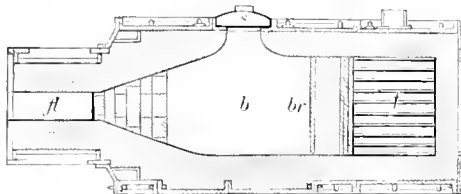

Fig. 9.—Puddling Furnace, horizontal section.

spiriting up flashes of blue flame from the bursting bubbles. This flame is mainly due to the burning of carbonic oxide. The puddler calls this the 'boiling,' and now the forehand works the rabble with great energy. As the rabble becomes softened at the working end and heated where held, it is rapidly plunged into a trough of water, and exchanged for a cool one. Careful observation shows that the puddler not only stirs the fluid, but gropes or *rabblies* along the bottom and sides of the furnace. Presently the melted mass thickens, solid granules are formed amidst the liquid. This the puddler describes as 'coming to nature.' It consists in the separation of infusible iron from the

fusible silicates; the oxidation of the silicon forming glassy silicic acid, which combines with oxide of iron or any other basic material within reach. These solid granules are at a welding heat, and the next business of the puddler is to weld them together, which he does by running off as much as possible of the liquid cinder, and squeezing the granules together into a spongy mass or ball. At this stage he lowers his damper and blocks the draught-hole with lumps of coal, in order to envelop the mass of exposed granular iron in a smoky reducing atmosphere. This prevents ruinous oxidation or 'cutting,' as the puddler calls it. Book-learned critics have pointed to the dense volumes of smoke which then issue from his chimney, and have accused him of ignorant wastefulness in the consumption of fuel. In this case the illiterate black-faced puddler understands the theory and the practice of his work, and the learned fine gentlemen are ignorant of both. The ball is now divided into portable dimensions (usually into three), and is rapidly carried to the hammer, where it is struck lightly at first, but with gradually increasing force as it becomes compressed into shape. The three balls may be united, commonly are, and thus beaten into a 'puddled bar.' During this heating, or 'shingling,' liquid cinder is squeezed from the mass like water from a sponge. More and more is squeezed by subsequent compression in passing the puddled bar through rolls similar to those shown in fig. 10. It first enters the large hole of either the square or the round set, and then while still red-hot passes successively through smaller and smaller openings. In the subsequent working of the iron this squeezing out of the impurities is continued. Thus, if it is made into boiler-plates or thin sheets, the bars made by passing through the rolls are cut into short lengths and 'piled'—i.e. stacked in square bundles, then heated and rolled out, during

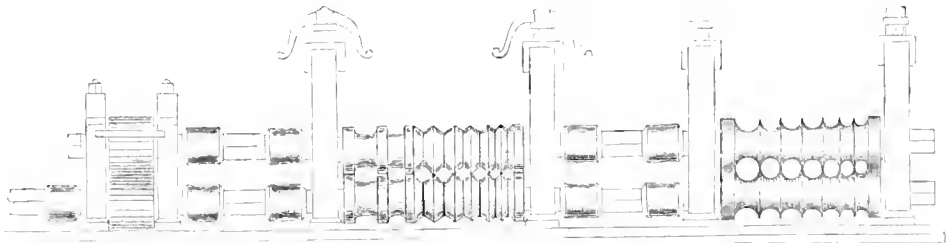

Fig. 10.—Rough and Finishing Rolls.

which working more fluid cinder is expressed. By such means the quality is improved up to a certain point, but beyond this mischief is done, for if the reheating is repeated too often the protecting remainder of carbon is removed, and the iron itself then oxidises—'burnt iron' is the result. This is triable, owing to the presence of particles of black oxide in the midst of the iron.

Formerly puddling was regarded merely as a process of oxidation produced by the action of air on the surface, and the puddler's stirring was described as a means of bringing fresh material to the surface. It was afterwards shown that large quantities of oxygen are supplied from below by the reduction of the oxide of iron in the fettling. The writer has tested this theory by excessive fettling with rich hematite and laborious rabbling; and has thereby turned out a weight of puddled bar exceeding that of the crude iron of the charge, the excess being due to the reduced iron from the hematite. But even this is not sufficient to account for the purification from sulphur and phosphorus; oxidation alone will not remove the remainder of these when their quantities are brought down to about $\frac{1}{2}$ per

cent. This has been fully proved by the failure of the fierce blast of the Bessemer converter to do so without also oxidising the iron itself. The writer's explanation of the puddler's success in purifying very bad pig-iron is that his process consists of oxidation *plus* washing; that he washes the granules of iron in liquid and basic cinder, as the laundress washes fibres of cotton, &c. in soap and water. The sulphur and phosphorus are found in the cinder, as the dirt and grease in the soap-suds. The subsequent squeezing out of the residual entangled liquid cinder by hammering, rolling, &c. is, according to this theory, strictly analogous to the *wringing* of the laundress. In connection with this impossibility of removing *all* the sulphur and phosphorus by mere oxidation it is desirable to correct a serious error that is repeated in most of our text-books—*even the best*. This is the statement that wrought iron contains no practically important quantity of carbon. This error is not shared by practical iron-makers who have studied the chemistry of their work. They know that some carbon or silicon, or both, must remain to protect the iron itself from oxidation when heated. It

usually contains about 2 per cent. of carbon, more or less, according to the quantity of silicon, which, being more readily oxidised than carbon, is a still more efficient protector. This is of great practical importance now that the Bessemer and Siemens-Martin processes, formerly used only for making steel, are applied to the manufacture of a malleable iron by pushing the oxidation to its utmost limit. If this limit is exceeded brittleness instead of toughness is the result, and a mistake in this direction involving certain portions of such a structure as the Forth Bridge might be fatal to the whole, as 'nothing is stronger than its weakest part.' For the making of such 'semi-steel,' see BESSEMER STEEL, and STEEL. And see FOUNDING.

Statistics as to the development and present position of iron manufactures will be found in the articles GREAT BRITAIN, BELGIUM, GERMANY, UNITED STATES, &c. For the processes of iron manufacture, see C. R. Alder-Wright, *The Chemical Changes accompanying the Smelting of Iron in Blast-furnaces*; Bauerman, *The Metallurgy of Iron*; Sir J. Lowthian Bell, *Chemical Phenomena of Iron Smelting*; W. Fairbairn, *Iron: Its History, Properties, and Processes of Manufacture*; W. H. Greenwood, *Steel and Iron*; C. Hoare, *Iron and Steel*; A. K. Huntington, *Metals, their Properties and Treatment*; *Iron, an Illustrated Weekly Journal*; *Journal of the Iron and Steel Institute*; M. H. C. Landrin, *Traité sur l'Acier*; F. Overman, *The Manufacture of Iron*; J. Percy, *Metallography: Iron and Steel*; J. A. Phillips, *Manual of Metallurgy*; W. M. Williams, *The Chemistry of Iron and Steel Making*. In German, E. F. Dürre, *Die Anlage und der Betrieb der Eisenhütten*; Dr Karl Hartmann, *Practisches Handbuch der Stahlfabrikation*; A. Ritter von Kerpely, *Bericht über die Fortschritte der Eisenhütten-Technik*; *Stahl und Eisen*; H. Wedding, *Die Metallurgie*. In French, *Annales des Mines*; L. Gruner, *Études sur les Hauts-fourneaux*; *Revue Universelle des Mines*.

IRON IN ITS PHYSIOLOGICAL AND THERAPEUTIC RELATIONS.—Iron is an essential constituent of the colouring matter of the blood-corpuscles of all vertebrate animals; and, according to the best authorities, one part by weight of iron is found in 230 parts of blood-corpuscles, and the total quantity of this metal in the blood of a man weighing 140 pounds is about 38 grains. It is the presence of iron in the blood that communicates to the ashes of that fluid their reddish-brown colour, the iron being found in them as the peroxide. The ashes of hair, of birds' feathers, of the contents of eggs, of gastric juice, of milk, and of most animal fluids, contain traces of iron.

Nothing is known with certainty regarding the chemical condition of the iron in the animal body; it probably exists as protoxide in the venous blood and peroxide in arterial blood. It is introduced into the system with the food and drink, and any excess beyond what is required is discharged with the excrements. It is thus a food rather than a medicine; but when an insufficient quantity is contained in the nutriment, or when from any cause the absorption of the iron contained in the food is interfered with, chalybeate medicines become necessary in addition. The iron that is set free within the system by the constant disintegration of blood-corpuscles is carried out of the system partly by the urine, chiefly by the colouring matter of the bile, which is highly ferruginous, and probably is in part eliminated by the hair. The exact part which the iron plays in the body is uncertain; but it is most probable that the power which the blood-corpuscles possess as oxygen-carriers is mainly due to the presence of iron.

In most forms of Anæmia (q.v.), especially Chlorosis (q.v.), the iron compounds are of incomparably more service than any other remedies. In amenorrhœa, in certain painful nervous affections, and in many conditions of debility the salts of iron are of especial service. They are contra-

indicated in plethora, and in most states accompanied by feverishness. The forms in which iron may be prescribed are very numerous, and vary considerably in their utility, according to the readiness with which they get taken up into the blood. Amongst the most generally used ferruginous medicines may be mentioned reduced iron, the tincture of the perchloride, the saccharated carbonate, the compound iron mixture (containing the carbonate), the sulphate, the tartarate, several citrates (especially the citrate of iron and quinine), &c. A course of Chalybeate Waters (see MINERAL WATERS) may often be prescribed with great advantage when the patient cannot bear the administration of iron in its ordinary medicinal form.

Iron Age, an archaeological term indicating the condition as to civilisation and culture of a people using iron as the material for their cutting tools and weapons. It is the last of the prehistoric stages of progress represented by the series of the three ages of Stone, Bronze, and Iron. But it has to be remembered that this sequence is not necessarily true of every part of the earth's surface, for there are areas, such as the islands of the South Pacific, the interior of Africa, and parts of North and South America, where the peoples have passed directly from the use of stone to the use of iron without the intervention of an age of bronze. In Europe the iron age may be defined as including the last stages of the prehistoric and the first of the protohistoric periods. As the knowledge of iron seems to have travelled over Europe from the south northwards, the commencement of the iron age was very much earlier in the southern than in the northern countries. Greece, as represented in the Homeric poems, was then in the transition period from bronze to iron, while Scandinavia was only entering her iron age about the time of the Christian era. The transition from bronze to iron in central Europe is exemplified in the great cemetery, discovered in 1846, of Hallstatt, near Gmunden, where the forms of the implements and weapons of the later part of the bronze age are imitated in iron. In the Swiss or La Tène group of implements and weapons the forms are new and the transition complete. The early iron age forms of Scandinavia show no traces of Roman influence, though these become abundant towards the middle of the period. The duration of the iron age is variously estimated according as its commencement is placed nearer to or further from the opening years of the Christian era; but it is agreed on all hands that the last division of the iron age of Scandinavia, or the Viking Period, is to be taken as from 700 to 1000 A.D., when Paganism in those lands was superseded by Christianity. The iron age in Europe is characterised by forms of implements, weapons, personal ornaments, and pottery, and also by systems of decorative design, which are altogether different from those of the preceding age of bronze. The implements and weapons are no longer cast but hammered into shape, and as a necessary consequence the stereotyped forms of their predecessors in bronze are gradually departed from, and the system of decoration, which in the bronze age consisted chiefly of a repetition of rectilinear patterns, gives place to a system of curvilinear and flowing designs. But the principal feature that distinguishes the iron age from the preceding ages is the introduction of alphabetic characters, and the consequent development of written language which laid the foundations of literature and historic record.

See *Howa Firdes, or Studies in the Archaeology of the Northern Nations*, by Kemble, edited by Latham and Franks (1863); *Scandinavia in Prehistoric Times: The Iron Age*, by Joseph Anderson, II., D. (1883); *The Industrial Arts of Denmark from the Earliest Times* (South Kensington).

Handbook), by Worsae (1882); *The Industrial Arts of Scandinavia in the Pagan Time* (South Kensington Handbook), by Hans Hildebrand (Lond. 1883).

Iron Bark Tree, a name given in Australia to certain species of Eucalyptus (q.v.), and particularly *E. resinifera*, or Red Gum, on account of the extreme hardness of the bark.

Ironclads, a term first applied to wooden ships of war strengthened by a more or less complete covering of iron armour-plates. Partial iron defences for war galleys seem to have been in use in the middle ages; the floating batteries used at the siege of Gibraltar in 1782 had bomb-proof roofs and sides, strengthened by leather and bars of iron. Systematic defences of this kind were advocated by numerous writers in France, America, and England, early in the 19th century. But the first regular use of iron armour on the sides of ships was when, during the Crimean war, the French made and sent to the Black Sea floating-batteries with armour $4\frac{1}{2}$ in. thick. In 1858 the French had four iron-plated line-of-battle ships building. The first British sea-going ironclad was the *Warrior* (1860), with $4\frac{1}{2}$ in. armour for the upper deck to the water-line; but, as iron was the material of which the ship was built, 'ironclad' became rather a misnomer. The term is still employed loosely for all armoured ships, turret-ships, barbette-ships, &c., even if the hull and framework are of iron and the armour (which in the *Invincible* is from 16 to 24 in. thick) is faced with steel (as in the *Edinburgh*, *Camperdown*, *Warspite*, &c.). See NAVY, and SHIPBUILDING.

Iron Cross, a Prussian order, instituted on March 10, 1813, by Frederick-William III., to be conferred for distinguished services in war. It was made of iron to commemorate the grim 'iron' period at which it was created. The decoration consists of a Maltese cross of iron, edged with silver, and is worn round the neck or at the button-hole. The order was revived by William I. on 19th July 1870, on the eve of the great war with France. The grand cross, a cross of double the size, is presented exclusively for the gaining of a decisive battle, or the capture or brave defence of a fortress.

Iron Crown. See CROWN.

Iron Gates. See DANUBE.

Iron Mask, THE MAN WITH THE. The story of the prisoner so called, confined in the Bastille and other prisons in the reign of Louis XIV., has long had a romantic interest for the readers of history. The first notice of him was given in a work entitled *Mémoires Secrets pour servir à l'Histoire de Perse* (Amst. 1745-46), according to which, he was the Duke of Vermandois, a natural son of Louis XIV. and of Mlle. de la Vallière, who, having given a box on the ear to his half-brother, the grand dauphin, had to expiate it with imprisonment for life. The assertion was without foundation, for the Duke of Vermandois died in camp in 1683; but the confidence with which it was made caused a deep sensation, and the romance of Monby, *L'Homme au Masque de Fer*, which immediately followed (Hague, 1746), was read with all the more avidity that it was prohibited. Voltaire, in his *Siècle de Louis XIV.*, treats the anecdote historically. According to him, the prisoner was young, and of a noble figure. In journeying from one prison to another he wore a mask, and was at last transferred to the Bastille, where he was treated with great distinction.

The first authentic information with regard to the Iron Mask was given by the Jesuit Griffet, who acted for nine years as confessor in the Bastille, in his *Traité des différentes Sortes de Prisons qui servent à établir la Vérité dans l'Histoire* (Liège,

1769). He brought forward the MS. Journal of Du Jonea, the lieutenant of the Bastille, according to which Saint-Mars arrived, on the 18th September 1698, from the Isle de Sainte-Marguerite, bringing with him in a litter a prisoner whom he had already had in custody at Pignerol. The prisoner's name was not mentioned, and his face was always kept concealed by a mask of black velvet. The journal mentions his death on the 19th day of November 1703, and that he was buried in the cemetery of St Paul. This is confirmed by the register of burials for the parish of St Paul's, where the prisoner is mentioned under the name of Marchiali.

After long silence Voltaire returned to the subject in his *Essai sur les Mœurs*, but he brought forward nothing new. In the seventh edition of the *Dictionnaire Philosophique* he related the story anew, under the head *Anc*, corrected his errors as to time from the journal of Du Jonea, and concluded with the assurance that he knew more about the matter than Griffet, but chose, as a Frenchman, to be silent. An addition to the article, apparently by the editor of the work, freely states the opinion that the Mask was an elder brother of Louis XIV. The writer declares that Anne of Austria had this son by the Duke of Buckingham, and being thus undeceived as to her supposed barrenness, brought about a meeting with her husband, and in consequence bore Louis XIV. Louis is held to have first learned the existence of this brother when he came of age, and to have put him in confinement, to guard against any possible unpleasant consequences. Saint-Michel published a book in 1790, in which he relates the story of the unfortunate being, and points to a secret marriage between Queen Anne and Cardinal Mazarin. What is remarkable is that not the court but Lamoignon continued to manifest an interest in the matter, and took every means to keep the identity of the prisoner in the dark. When the Bastille fell the prisoner's room was eagerly searched, and also the prison register; but all inquiry was vain.

The Abbé Soulavie, who published *Mémoires de Marshal Richelieu* (London and Paris, 1790), tries to make out from a document written by the tutor of that unfortunate prince that the Iron Mask was a twin-brother of Louis XIV. A prophecy had announced disaster to the royal family from a double birth, and to avoid this Louis XIII. caused the last born of the twins to be brought up in secret. Louis XIV. learned of his brother's existence only after the death of Mazarin, and that brother, having discovered his relation to the king by means of a portrait, was subjected to perpetual imprisonment. This view of the matter was the one almost universally prevalent till the time of the Revolution. It is also followed in Zschokke's German tragedy, and in Fournier's drama, founded on the story. In Grimm's correspondence may be found the legend of the birth of a twin-brother of Louis XIV., but history avers that seventeen persons were present and witnessed the delivery of the queen of one male infant only. As regards the intrigue of Anne of Austria with the Duke of Buckingham the dates make the supposition absurd, as forty-eight years elapsed between their *adulter* and the first imprisonment of the Mask in Pignerol.

The first conjecture of what till recently seemed to be the truth is contained in a letter dated 1770, written by a Baron d'Heiss to the *Journal Encyclopédique*. The same is repeated by Louis Dutens in his *Intercepted Correspondence* (1789), who declares that there is no point of history better established than the fact that the prisoner with

the Iron Mask was a minister of the Duke of Mantua. This minister, Count Matthioli, had pledged himself to Louis XIV. to urge his master the duke to deliver up to the French the fortress of Casale, which gave access to the whole of Lombardy. Though largely bribed to maintain the French interests, he began to betray them; and Louis XIV., having got conclusive proofs of the treachery, contrived to have Matthioli lured to the French frontier, secretly arrested, 23d April 1679, and conveyed to the fortress of Pignerol, which was his first prison. The conclusion of D'Heiss and Dutens, that Matthioli was the Iron Mask, though acute, was only a conjecture. But the documents discovered and published by M. Roux-Fazillac in his *Recherches historiques et critiques sur l'Homme au Masque de Fer* (1800), by M. Delort in his *Histoire de l'Homme au Masque de Fer* (1825), and M. Marius Topin, in his *Man with the Iron Mask* (trans. 1869), seemed to leave little doubt on the subject, and the public had apparently made up its mind that the secret was at last discovered, when a still more recent work by a French officer, M. Th. Jung, *La Verité sur le Masque de Fer (Les Enprisonnements) d'après des Documents inédits des Archives de la Guerre et autres dépôts publics, 1664-1703* (1873), conclusively showed that Matthioli could not have been the mysterious prisoner. This Italian adventurer was sent to Pignerol six years after the Mask entered that fortress. He was left behind in Pignerol when Saint-Mars removed the Mask to the Bay of Cannes, and his death there was never kept secret. Matthioli could not speak French; but the *mystery*, the man in the mask, spoke French with a foreign accent, was over the middle height, tall, well made, and fond of music. It says little for the perspicacity of either M. Topin or of his readers that Matthioli should ever have been accepted as the owner of the famous Mask.

M. Jung's hypothesis is vastly more meritorious; in fact, he marshals his facts so dexterously that we should almost say he had succeeded in proving that the Man in the Iron Mask was the unknown head of a widespread and formidable conspiracy, working in secret for the assassination of Louis XIV. and of some of his ablest ministers. The severity of M. Jung's labours with reference to this subject will be understood when it is stated that in the course of his researches he had to examine some seventeen hundred volumes of despatches and reports in the bureau of the Ministry of War. The adventurer upon whom he fastens the Mask was a certain soldier of fortune, a M. de Marchiel, related to several families in Lorraine, and apt to assume their names when an *alias* was required for his purposes. Seized by Louvois's orders at the ford of Peronne, on the morning of March 29, 1673, he was first forwarded to the Bastille. There Louvois saw him, and sent him to Pignerol and to the care of Saint-Mars. From that hour the jailor never parted from his strange prisoner. De Marchiel went with him to Exilles (1687), to St. Marguerite, and died in the Bastille, November 19, 1703. His funeral cost forty livres, and it is entered in the register of the parish of St. Paul as that of 'M. de Marchiely.' His clothes and his Iron Mask were burned, and there the few facts known about this man end. The names and dates all hang so well together that this conjecture is far the most reasonable that has yet been made. But nothing has been proved, except that the Mask was none of the other eleven persons he has been supposed to be. Nothing more will ever be proved until the treasures of the Vatican give up the secret, a secret which the Mask's confessor must certainly have known, and which he *may* have revealed to his ecclesiastical superiors in Rome.

Ironsides, a name popularly applied to the regiment of a thousand horse which Cromwell raised mainly in the eastern counties for service against the king early in the great Civil War. The name, already given for his bravery to an English king, Edmund (q.v.), was first attached to Cromwell himself, but passed easily to the men at whose head he first appeared at Edgehill. Almost from the beginning he saw that real religious enthusiasm was the only force adequate to match the chivalry of the cavalier, and he spent his own money freely on the equipment of his men. 'Old decayed serving-men, and tapsters, and such kind of fellows will never be able to encounter gentlemen,' as he said to Hampden, and the soldiers he gathered round him were stalwart and substantial yeomen, emphatically 'men of religion,' who 'made some conscience of what they did,' who knew the fear of God and no other fear at all. Social distinctions and religious conformity were made subordinate to competence and honesty. 'Better plain men than none; but best to have men patient of wants, faithful and conscientious in their employment,' wrote Cromwell; and elsewhere, 'I have a lovely company; you would respect them did you know them; they are no Anabaptists; they are honest, sober Christians; they expect to be used as men.' And his Ironsides nobly justified their captain's expectations. At Winchby they charged 'singing psalms,' cleared Lincolnshire and the eastern counties of the Cavaliers, endured the shock of Rupert's horse at Marston Moor, and scattered them like chaff before the wind. The whole parliamentary army was next reorganised on the model of Cromwell's brigade, but it was still the stubborn valour of the Ironsides in the left at Naseby that changed the day from defeat to a crushing victory, and practically closed the war. 'Truly they were never beaten,' said Cromwell in a speech the year before his death, 'and whenever they were engaged against the enemy they beat continually.'

Ironton, capital of Lawrence county, Ohio, on the Ohio River, 142 miles above Cincinnati. It is the chief business centre of an important iron region, which gives employment to numerous furnaces, foundries, and other manufactories. Pop. 8857.

Ironwood, a name bestowed in different countries on the timber of different trees, on account of its great hardness and heaviness.—*Actinodendron veru* belongs to the natural order Myrtaceæ, and is a native of Java and other eastern islands. Its wood is much valued by the Chinese and Japanese for making rudders, anchors, &c., and is imported into Britain in small quantities under the name of Ironwood. The bark is used in Japan as a remedy for diarrhoea and mæms discharges. *Mesua ferrea*, a tree of the natural order Guttifera, is a native of the East Indies, and is planted near Buddhist temples for the sake of its fragrant flowers, with which the images of Buddha are decorated. The timber known as Ironwood is very hard, as is that of *M. speciosa*, another tree of the same genus and region. The wood of *Uyris andulata*, of the order Diosmeacæ, is called White Ironwood at the Cape of Good Hope. It is very hard and tough, and is chiefly used for axles, ploughs, and other agricultural implements. The wood of *Olea laurifolia*, a species of olive, is called Black Ironwood in the same country, and is used for the same purposes and for furniture. *O. capensis* is the Ironwood of the Dutch settlers at the Cape of Good Hope, and its wood has similar properties to and is used for the same purposes as the foregoing. *Cappalia subercolan* natural order Sapindaceæ—is the

Ironwood of the islands of Bourbon and Amboyna. The wood is red in colour, very heavy, knotty, and difficult to work; it is used chiefly for making stakes and poles.—*Sideroxylon inornatum*—natural order Sapotaceæ, belonging to the Cape of Good Hope—is named Ironwood and also *Melkhout* by the settlers. The timber is extremely hard, and so heavy that it sinks in water. It is extensively used in boat and bridge building and for agricultural purposes.

Irony (Gr. *αἰρωνία*, *αἰρῖν*, 'a dissembler'), the name applied to a figure which enables the speaker to convey his meaning with greater force by means of a contrast between his thought and his expression, or, to speak more accurately, between the thought which he evidently designs to express and that which his words properly signify. It may be employed to convey assent and approbation as well as the contrary, but it is more properly a weapon belonging to the armoury of controversy, by means of which weight and point may be added to the gravest part of the argument. The dialogues of Plato are admirable examples of a subtle *dialectic* irony, in which the opinion of the adversary is put respectfully in the foreground, and the appearance of deference is never dropped until the supports on which it rests are one by one withdrawn, and the whole is completely undermined and seems to sink by the weight of its own absurdity. Of this rare art in modern literature there is nothing worthy of comparison, save the *Provincial Letters* of Pascal. The *Minute Philosopher* of Bishop Berkeley is one of the most unfortunate attempts at its revival. A more recent master of dialectic irony is the Danish theologian and philosopher, Kierkegaard. The highest triumphs of irony consist not in refutation and demolition, but in clear demonstration of the truth once the fallacy has been exposed and overthrown. Of what may be called practical irony numberless instances of the most various kinds occur in life. A man humours the follies of another to render them more extravagant, either for his own amusement or his victim's ultimate profit; another, under the mask of friendship, panders to the wishes of some deluded man to lead him to his ruin. In such spirit Timon gave his gold to Alcibiades, the witches fed the ambitious hopes of Macbeth, and Mephistopheles echoed the aspirations and the despair of Faust. Fate itself brings bitter irony to bear upon the hopes of mortal life, in the inevitable reflection how little the actual good and ill have corresponded with the antecedent hopes and fears. The calm retrospect of an unembittered age, no longer disturbed by the passions of the actor, is ever tinged with a genial sense of the dumb irony of things as it recognises at last that life has been little more than a vain pursuit of the phantoms of youth. And alike in the broad arena of history we find human impatience and temerity punished by the relentless hand of destiny, as in the signal and sudden reverses that follow close on the heels of arrogant ambition. And so in the microcosm of the drama, which must be a faithful image of human existence concentrated in the mimic sphere. An admirable amplification of this thought as applied to one of the greatest tragedians of all time will be found in Thirlwall's famous essay, 'On the Irony of Sophocles,' in his *Essays, Speeches, and Sermons*, edited by Dean Perowne (1880).

Iroquois, formerly a great confederation of Indian tribes, recognised as a distinct branch of the American family. At the beginning of the 17th century they included the Mohawks, Oneidas, Onondagas, Cayugas, and Senecas, and became known as the 'Five Nations'; in 1715 they were joined by a related tribe, the Tuscaroras, and

henceforward were known as the 'Six Nations.' Each tribe managed its own affairs, under its own sachems, and a council of fifty sachems met annually and disposed of questions affecting the confederation as a whole. The chiefs, who, like the sachems, were of equal rank, but who owed their position to personal valour alone and did not form a hereditary body, exercised leadership in time of war only. The confederation was found by the earliest settlers in possession of the greater part of the present state of New York, but by the end of the 17th century all the tribes between the Atlantic and the Mississippi, and from the St Lawrence to the Tennessee, had been brought under its influence. With the Dutch, and afterwards with the English, the Iroquois always maintained friendly relations, even taking sides with their allies during the Revolution; to the French, on the other hand, they were bitterly hostile, and their enmity had an important effect in checking the growth of French influence in North America. After the Revolution the Mohawks crossed into Canada under Joseph Brant (q.v.), and are now settled on two reservations to the north of Lakes Erie and Ontario. The Cayugas are scattered, and some hundreds only of the Tuscaroras have found a home among the Mohawks; but most of the Oneidas are settled at Green Bay, Wisconsin, most of the Senecas in Western New York, and the Onondagas still hold their beautiful valley near Syracuse, New York. The Iroquois probably never exceeded 25,000, and they still number nearly half as many, most of them in the United States. Schools and missions have met with considerable success, and civilisation is making marked progress among the descendants of this remarkable confederation, while some of their number have attained to distinction as soldiers, engineers, &c.

Irradiation. When a bright object is looked at, an image of it is formed on the retina of the eye. The receiving-apparatus there consists of a number of separate stimulable elements or sets of elements; and for the maximum distinctness of vision no one of these elements should be at all affected by stimulation of its neighbours. If, however, the object be brilliant the image on the retina is very bright, and neighbouring sensitive elements participate in the excitement; a bright object thus looks larger than it is. Examples: bright white letters on a black ground look larger than they are; black letters on a bright white ground look smaller; a white-hot wire appears thickened; the new moon appears larger than the copper-colored 'old moon' which it appears to 'nurse'; and, especially, an electric incandescent lamp often appears, on account of the extreme brilliancy of its attenuated filament, to be almost filled with light.

Irrational Numbers, a term applied to those roots of numbers which cannot be accurately expressed by a finite number of figures. For instance, $\sqrt{2}$ is an irrational number. If the diameter of a circle is one foot the circumference is an irrational number. Irrational numbers have been defined to be numbers which are incommensurable with unity. They are also termed Surds.

Irrawaddy. See **IRAWADI**.

Irregulars, a general term applied to partially-equipped troops engaged in partisan warfare, such as the Franc-tireurs during the Franco-German war of 1870-71. It is also used in connection with the native armies of British India which were re-organised throughout, during the years 1857-61, on what is called the 'Irregular System'—that is to say, with only eight or nine European officers instead of a complete establishment of from twenty-one to

twenty-four. Previous to the Mutiny of 1857 most of the native regiments were on the regular system, the troops or companies being commanded by Europeans, with others under them as subalterns, majors in charge of wings, and a lieutenant-colonel in command, assisted by the usual regimental staff—viz. adjutant, quartermaster, and surgeon. Many of these officers held other appointments, either civil or military, during peace, but rejoined their regiments on the outbreak of war. Only some seven or eight would be found doing regimental duty continuously. A few irregular corps existed having only three European officers, commandant, second in command, and adjutant, attached from the regulars and drawing high rates of pay. The organisation introduced into all native regiments after the Mutiny gives to each cavalry regiment nine European officers from the Indian Staff Corps—viz. the commandant, four squadron commanders, and four squadron officers (one the adjutant). The troop officers are natives, and there is a native adjutant. An infantry battalion has eight European officers—viz. the commandant, two wing commanders, and five wing officers, of whom one is the adjutant and another the quartermaster; the company officers are natives, and there is a native adjutant. The Corps of Guides of the Punjab Frontier Force, consisting of six troops of cavalry and eight companies of infantry, has fourteen European officers. A native battery of mountain-artillery has a commandant and three subalterns, all British, with three native officers under them. The native sappers and miners have a larger establishment of British officers, and also forty European non-commissioned officers. The routine regimental duties are carried on by the native officers, who live in the lines alongside their men, but in separate quarters. The British officers exercise a general system of administration and supervision, and live in cantonments generally at some distance from the lines, except when on service or in camp.

Irrigation (Lat., 'watering'), a method of producing or increasing fertility in soils by an artificial supply of water, or by inundating them at stated periods. Irrigation was probably first resorted to in countries where much of the land must otherwise have remained barren from drought, as in Egypt, where it was extensively practised nearly 2000 years before Christ, and where great systems of canals and artificial lakes were formed for the purpose. Extensive works, intended for the irrigation of large districts, existed in times of remote antiquity in Mesopotamia, Persia, India, China, and some other parts of the East; and in such of these countries as have not entirely lost their ancient prosperity such works still exist. Some plants also require a very abundant supply of water, and irrigation has become general where their cultivation prevails. This is particularly the case with rice, the principal grain of great part of Asia. In Europe irrigation prevails chiefly in the south, where it was extensively practised by the Romans; and it is most extensively practised in northern Italy, and in some parts of Spain and southern France.

Irrigation in Britain, where it was hardly practised till the 19th century, and in most parts of Europe except Italy, is almost exclusively employed for the purpose of increasing the produce of grass by converting the land into water-meadows. The value of it, even for this one purpose, does not seem to be sufficiently understood. Poor heaths have been converted into luxuriant meadows by means of irrigation alone. But in the countries in which irrigation is most extensively practised the production of all crops depends on it.

The irrigation of land with the sewage water of towns is, under another name, the application of liquid manure. In no small degree the water of

rivers and of springs depends on its organic and mineral constituents for its fertilising properties, so that the application of it is not in principle different from that of liquid manure; but it must be borne in mind that the mere abundance of water itself is of great importance for many of the most valuable plants, as the most nutritious substances brought into contact with their roots are of no use to them unless in a state of solution; whilst it is an additional recommendation of irrigation that the supply of water most favourable to the growth of many valuable plants is destructive of some which in many places naturally enumber the soil, as heath, broom, &c. The water which is used for irrigation should be free from mud and such impurities as mechanically clog the pores of leaves, or cover up the *hearts* of plants, and interfere with their growth. Irrigation is far from being so extensively practised in Great Britain as would seem desirable. There are few farms in the British Isles which would not give a handsome return for artificial watering in a dry year—i.e. if the water could be obtained and applied at a reasonable cost. In many instances the produce might be increased two, three, or even fourfold. The amount of moisture which farm crops require to ensure their full development is greater than would be readily conceived. At Rothamsted it was found by Lawes and Gilbert that an acre of wheat in five months and eighteen days evaporated through its leaves no less than 335½ tons of water. Light porous soils benefit most from irrigation; sandy soils, with a little admixture of clay and marl, usually most of all. Except in tropical countries, still retentive clay would not as a rule be benefited by irrigation, and might be injured by it, at any rate for arable farming. Thorough drainage, natural or artificial, is a necessary accompaniment of successful irrigation—necessary so that the soil may not become 'water-logged,' but benefited by the water percolating through it. Soil wholly or partially uncovered by vegetation is liable to be robbed of nitrogen by the rain or irrigation water washing nitrates into the drains or down beyond the reach of the plants. This is avoided in grass land by the roots of the grasses engaging the nitrogen. Irrigation may benefit the land in various ways, most usually (1) by softening and disintegrating the soil in percolating through it; (2) by bringing additional plant food into it; (3) by facilitating the dissolving, preparing, and distribution of the plant food already in the soil; and (4) by the oxidation of any excess of organic matter in the soil, leading thereby to the production of useful carbonic acid and nitrogen compounds. The extent of water-meadows in England is stated to be not more than 100,000 acres. They are mostly confined to the west and south of England. Individual farms, irrigated with sewage water, are to be met with in many parts of England, but the most successful instance of sewage irrigation in Great Britain is to be found near Edinburgh, where an extensive tract of meadows lying between Portobello and Leith yields a rent of £15 to £35 an acre; the grass is cut from three to five times a year, and over ten tons an acre have been obtained at a cutting. See SEWAGE, MANURE.

The methods most generally pursued are what are known as bed work irrigation, catch-work irrigation, and subterraneous irrigation. The first method can be conveniently applied only to ground which is nearly level, and may cost from £20 to £40 per acre. The catch-work method is very much less costly, and can be applied to land whether it is level or not. By the last system the soil is saturated with water from below.

In some parts of the United States irrigation is of vital importance; in 1890 the total area of the

arid lands of the west was 1,331,151 sq. m. In the east the principal use of irrigation is in the rice-fields of South Carolina and Georgia; but such western states as Colorado and Utah are altogether dependent on it, owing to the scarcity of the rainfall. This is true also, to a great extent, of southern California. In all these arid districts hundreds of miles of canals and ditches have been constructed in addition to the mining flumes utilised for irrigation purposes; and as a result wide tracts of desert have been turned into a productive farming country. More recently irrigation has been introduced in western Kansas, largely by canals from the Arkansas River; although here, as in eastern Colorado and California, a great part of the water-supply is obtained from artesian wells. In Arizona, also, it is expected that wide tracts now uninhabitable will be rescued with the aid of irrigation.

In Australia irrigation on an American scale, and according to American methods, has transformed hundreds of thousands of acres, once covered with scrub, into luxuriant vineyards, orchards, and orange-groves, especially in the lower basin of the Murray. The importance of irrigation to the Cape is noticed in the article on that colony; and the irrigation works of India and Ceylon are referred to at INDIA, CEYLON. Egypt (q.v.) is the land most entirely dependent on systematic and careful irrigation.

Irritability in Plants, a term employed to designate phenomena very interesting and curious, but than which none connected with vegetable life are more imperfectly understood. Such are the phenomena of what is usually called the Sleep (q.v.) of plants; the motion of the spores of many cryptogamic plants by means of cilia; the motions of some of the lowest Algae; those caused by agitation or by the touch of a foreign body in the leaves of Sensitive Plants (q.v.); the motions of Insectivorous Plants (q.v.), &c.

Irritation is the term applied to any morbid excitement of the vital actions not amounting to inflammation, and it often but not always leads to that condition.

Irtish, a river of Siberia, the chief affluent of the Obi (q.v.), rises at the east end of the Altai Mountains, passes through Lake Saisan, breaks through the Altai in the west at the bottom of a savage gorge, and flows north-westwards across the steppes of Western Siberia to join the Obi, from the left, at Samarow. At that point it has a width of 2000 yards; its total length is 1620 miles; the area of its basin, 647,000 sq. m. The important towns of Semipalatinsk, Omsk, and Tobolsk stand on its banks. From April to November it is navigable from its mouth as far as Lake Saisan; during the rest of the year traffic is carried on by means of sledges. Its current is gradually shifting eastwards. Its best-known tributaries are the Buchtarma and On from the right, and the Tobol and Ishim from the left.

Iruu, a town in the Spanish province of Guipuzcoa, on the Bidasson, near the French frontier, 24 miles by rail SW. of Bayonne. In 1837 General Sir De Lacy Evans (q.v.) captured it from the Carlists. Pop. 7040.

Irvine, a seaport of Ayrshire, on the river Irvine, $1\frac{1}{2}$ mile from the Firth of Clyde, and 11 miles by rail N. of Ayr, 29 SW. of Glasgow. Made a sub-port of Troon in 1863, its harbour has been improved since 1873; and there are chemical works, foundries, grain-stores, &c. The bridge (1746-1837), the new town-hall (1859), a statue of Lord-justice-general Boyle (1867), and the academy (1814) are features of the town, which became a royal burgh about 1230, and which with Ayr, &c.

returns one member to parliament. It was the birthplace of Galt and James Montgomery, and has memories also of Burns and the Buchanites. Pop. (1841) 4594; (1891) 9086.

Irving, EDWARD, was born in the town of Annan, Dumfriesshire, August 4, 1792, and at thirteen entered the university of Edinburgh. In 1810 he became a schoolmaster at Haddington, in 1812 at Kirkealdy, where three years later he was licensed to preach; and in 1819 he was appointed assistant to Dr Chalmers, then a minister in Glasgow. His sermons did not prove very popular; Chalmers himself was not satisfied. In 1822 Irving accepted a call to the Caledonian Church, Hatton Garden, London. His success as a preacher in the metropolis was such as had never previously been witnessed. After some years, however, the world of fashion got tired of Irving; but it was not till his more striking singularities of opinion were developed that fashion finally deserted him. At the close of 1825 he began to announce his convictions in regard to the second personal advent of the Lord Jesus, in which he had become a firm believer, and which he declared to be near at hand. This was followed up by the translation of a Spanish work, *The Coming of the Messiah in Majesty and Glory*, by Juan Josafat Ben Ezra, which professed to be written by a Christian Jew, but was in reality the composition of a Spanish Jesuit. Irving's introductory preface is regarded as one of his most remarkable literary performances. In 1828 appeared his *Homilies on the Sacraments*. He now began to elaborate his views of the incarnation of Christ, asserting with great emphasis the doctrine of his oneness with us in all the attributes of humanity. The language which he held on this subject drew upon him the accusation of heresy; he was charged with maintaining the sinfulness of Christ's nature. But he paid little heed to the alarm thus created. He was now deep in the study of the prophecies, and when the news came to London in the early part of 1830 of certain extraordinary manifestations of prophetic power in the west of Scotland, Irving was prepared to believe them. Harassed, worn, balled in his most sacred desires for the regeneration of the great Babylon in which he dwelt, branded by the religious public and satirised by the press, the great preacher, who strove above all things to be faithful to what seemed to him the truth of God, gasped at the new wonder with a passionate earnestness. Matters soon came to a crisis. Irving was arraigned before the presbytery of London in 1830 and convicted of heresy, ejected from his new church in Regent's Square in 1832, and finally deposed in 1833 by the presbytery of Annan, which had licensed him. His defence of himself on this last occasion was one of his most splendid and sublime efforts of oratory. The majority of his congregation adhered to him, and gradually a new form of Christianity was developed, commonly known as Irvingism, though Irving had really very little to do with its development (see CATHOLIC AND APOSTOLIC CHURCH). Shortly after his health failed, and, in obedience, as he believed, to the Spirit of God, he went down to Scotland, where he sank a victim to consumption. He died at Glasgow, December 8, 1834, in the forty-second year of his age. See Carlyle's *Miscellaneous Essays* and his *Reminiscences*, and Mrs Oliphant's *Life of Edward Irving* (1862).

Irving, SIR HENRY (born JOHN HENRY BRODRIBB), actor, was born in 1838 at Keinton-Mandeville, Somerset. Educated in London, he was for a time engaged as a clerk in the city, but, having a strong inclination for the stage, made his first appearance at the Sunderland Theatre in 1856. After next

playing at Edinburgh for nearly three years, he first performed in London on September 25, 1859, at the Princess's Theatre. He achieved but a moderate success, though some dramatic readings which he gave at this time at Crosby Hall were warmly commended by the critics. He next played at Glasgow, and then for nearly five years at the Manchester Theatre Royal. After a brief engagement at Liverpool in 1866 he appeared with Miss Kate Terry at Manchester in *Hunted Down*. An invitation to London followed, and he appeared at St James's Theatre with much success as Doricourt in *The Belle's Stratagem*, Dornton in *The Road to Ruin*, and (at the Gaiety) as Mr Chenevix in *Uncle Dick's Darling*. Performances at other London theatres followed, and in 1870, at the Vaudeville Theatre, he made a distinct mark as Digby Grant in Albery's comedy of *The Two Roses*. Migrating to the Lyceum in November 1871, he further added to his reputation by his fine representation of Mathias in *The Bells*. Other impersonations succeeded, including Charles I., Eugene Aram, Richelieu, and Louis XI., until, on the 31st of October 1874, he created genuine interest by his unconventional performance of Hamlet. This Shakespearian masterpiece ran for two hundred nights, and, although the public were divided as to the general merits of the representation, full justice was done to the actor's abilities, and it was universally admitted that Mr Irving had established his reputation as a tragedian of real power and originality. Among other successes under Mrs Bateman's management of the Lyceum were *Macbeth*, *Othello*, *Richard III.*, and *The Lyons Mail*. In December 1878 Mr Irving entered upon his memorable management of the Lyceum Theatre, where his triumphs have been shared by Miss Ellen Terry. He soon added a succession of romantic characters to his repertoire. After performances of *Hamlet*, *Othello*, and *The Merchant of Venice*, which were marked by scenic as well as histrionic excellence, this popular actor appeared in 1880 in *The Corsican Brothers*; in Lord Tennyson's drama of *The Cup* in 1881; in *Romeo and Juliet* and *Much Ado about Nothing* in 1882; *Twelfth Night* in 1884; W. G. Wills's *Olivia* in 1885; *Faust*, adapted by Wills, in 1886; *The Dead Heart* in 1889; *King Lear* in 1892; *Becket* in 1893; *King Arthur* in 1895; *Cymbeline* in 1896, &c. Since 1883 Irving and his company have repeatedly been received with enthusiasm in the United States. He was knighted in 1895, and made D.C.L. of Oxford in 1896. Notwithstanding certain mannerisms of voice, gait, and gesture, he is undoubtedly at the head of contemporary English actors, and he has done much to redeem the stage from formality and mediocrity. See works on Irving by Joseph Hatton (1884), Frederic Daly (1884), William Archer (1885), and Percy Fitzgerald (1893).

Irving, WASHINGTON, was born in the city of New York, April 3, 1783, and died at Tarrytown, New York, November 28, 1859. Copyright 1890 in U.S. His father's family were Scotch, by J. B. Lippincott and claimed descent from William Company de Irwyn, secretary and armour-bearer of Robert Bruce; his mother was English, attached to the Episcopal Church, and of a loving, sunny temper. His education was scanty and desultory. His brothers were sent to college, but he showed no inclination to study, being 'a dreamer and a saunterer.' This arose in part from his tendency to pulmonary disease. He began to read law at the age of nineteen, but after two years, his health being precarious, his brothers sent him to Europe. He landed at Bordeaux in 1804, and went by Marseilles to Italy, escaping with difficulty from Bonaparte's police, who persisted in regarding him as

an English spy. At Rome he was intoxicated by Italian art, and having met Allston, the American painter, was tempted to become an artist, but thought better of it. He visited Paris, the Netherlands, and London, where he saw John Keble and Mrs Siddons. In 1806 he returned to New York in improved health, and was admitted to the bar. Those were 'Corinthian days,' and he led a rather idle life; much in society, and greatly admired.

His first writing was in the *Salmagundi*, a semi-monthly sheet in imitation of the *Spectator*, conducted jointly by himself, his brother William, and J. K. Paulding. It ran for twenty numbers, and then stopped without explanation in the fullness of success. There was considerable merit of a superficial sort in those early attempts, but there was no evidence of a serious literary purpose, for the papers apparently were written with a view only to social distinction. His first characteristic work, and the one by which he will be best known to posterity, was *A History of New York, by Diedrich Knickerbocker*, published in 1809. All readers of English know the little man in knee-breeches and cocked hat as one of the permanent figures in the gallery of literary portraits. The *History* has some grains of truth, but is openly a good-natured burlesque upon the old Dutch settlers of Manhattan Island. The humor and the gravity which mask it are alike irresistible. It may be doubted if there is in the language a more delightful or more perfectly-sustained piece of drollery. Readers of Scott will remember his warm praise of the book, written while 'his sides were sore with laughing.' In the United States it was universally read; and so abiding has been the impression that it is far oftener quoted than any sober historical work. It is to the American people as *real* in its way as the *Pilgrim's Progress*.

For many years after this Irving was in partnership with his brothers in a mercantile business that had relations on both sides of the Atlantic; but in the end they were unsuccessful; and when later he had won his place among authors and was receiving a good income, he supported two of his brothers and five nieces with unselfish devotion. In May 1815 he went to Europe for the second time, and did not return for seventeen years. It was in 1818 that the misfortunes of his firm culminated in bankruptcy, and thereafter he turned his whole attention to literature. He declined liberal offers for magazine work, and would undertake nothing that was to interfere with his plans. The first number of the *Sketch Book* appeared in New York in 1819, and the last in 1820. It was received in the United States with universal delight. Its early success in Great Britain was largely due to the powerful support of Scott. All the pieces in this miscellany have a certain charm—if for nothing more, for their felicitous touch and purity of style. The chief interest, however, centres in 'Rip Van Winkle,' 'The Legend of Sleepy Hollow,' and 'Westminster Abbey.' The last is one of the most finished descriptive essays of our century, though perhaps a little lacking in simplicity. The two legendary tales are in a way related to the *History of New York*, and have had a currency and an influence difficult to measure. 'Rip Van Winkle' is a distinct creation of genius, and with its fellow has made the lower reach of the Hudson classic ground. For the first time there had been produced in the United States a literary work on the highest level of contemporary excellence. *Beauchefield Hall* (1822) fairly maintained but did not raise the author's reputation. It was scarcely necessary, for *Geoffrey Hamlyn, Gent.* was already at the summit of favour. After a few years passed on the Continent he published (1821) *Tabs of a*

Traveller, a work which he thought his best in regard to style, but which some consider to be over-refined.

In 1826 he went to Spain and began the long and arduous studies which were the foundation of his more important serious works. These were *The Life of Columbus* (1828), *Conquest of Granada* (1829), *Voyages of the Companions of Columbus* (1831), *The Alhambra* (1832), *Legends of the Conquest of Spain* (1835), *Mahomet and his Successors* (1850). The last two or three of the works just named were only sketched or partly written before his return to the United States in 1832, but they are given together with the group of which they form part. It was Irving who first revealed to English readers the rich stores of Spanish history and romance; and whatever may be done to correct or enlarge his relations, to him must be given the praise of having produced some of the most fascinating books in existence. He had intended to write the history of the conquest of Mexico, for which he had collected materials, but generously, and to his own loss, relinquished his design to Prescott when he learned that the latter proposed to undertake it. At the end of this sojourn in Spain Irving was for a short time secretary to the United States Legation in London. On his return to his native city (1832) he was received with great enthusiasm. He declined political honours, and continued his literary work. Having made an excursion in the then Far West, he published (1835) *A Tour on the Prairies*. In the same year he published *Recollections of Abbotsford and Weststead Abbey*. He was also at work upon the last of the books in the Spanish series. In writing *Astoria* (1836) he was assisted by his nephew, his future biographer. *The Adventures of Captain Bonneville* (in the Rocky Mountains) appeared in 1837. His biography of Goldsmith was mainly written about this time, though not published until 1849. He remodelled for his own residence an old Dutch house in Tarrytown, near the scene of his legend of Sleepy Hollow. This became well known in after years under the name of Sunnyside. But his intended retirement was postponed by his appointment in 1842 as United States minister to Spain. He returned in 1846 and once more set himself to work. *Goldsmith* and *Mahomet* appeared as already mentioned; then, in 1855, *Wolfert's Roost*, a miscellany. His last work was the *Life of George Washington* (5 vols. 1855-59).

Irving was never married. In his youth he was betrothed to Miss Hoffman, a lovely young lady of eighteen, daughter of the lawyer with whom he pursued his studies. Separated from her by her untimely death, he remained all his life faithful to her memory. In his works there is to be observed a delicacy of feeling towards woman, a chivalrous deference as well as tenderness and affection. He was also exceedingly fond of children and always beloved by them. In his youth he was well made and handsome, and then, as afterwards, was always courted by the best society. Sentiment and abundant humour characterise his writings; but above all, he had the power to seize the attention of cultivated readers by his keen observation, his graphic touches of description, and his limpid and musical style. The early books which first gave him fame, and those which came from his studies in Spain, are the best, for in them his genius is conspicuous. The later productions are respectable, but would not have given him the high rank he deservedly holds. His was a fortunate and honourable life; and, on the whole, though inferior to one or two in genius, he must be pronounced thus far the most successful of the writers of the New World. His *Life* was written by his nephew, Pierre M. Irving (5 vols. 1862-64). There is also

an excellent short biography by Charles Dudley Warner (1881).

Irvingites. See CATHOLIC AND APOSTOLIC CHURCH.

Isaac, one of the Hebrew patriarchs, the son of Abraham and Sarah, and half-brother of Ishmael. His story in Genesis makes him born when both his parents were advanced in age, and die at Hebron at the age of 180, leaving two sons, Jacob and Esau. The Midrash ascribes to him, in allusion to Gen. xxiv. 63, the institution of the afternoon prayer.

Isaac I. COMNENUS, emperor of Constantinople, was the first of the Comneni who attained to that dignity. Under the successors of Basil II. Isaac served in the army, winning the hearts of officers and men by his prudence and uprightness, and on the deposition of Michael VI. in 1057 was elevated to the throne. He established the finances of the empire on a sounder and more stable footing, and, braving the patriarch's threat of excommunication, even laid the clergy under contribution at the tax-collections. He repelled the Hungarians attacking his northern frontier; and then, resigning the crown (1059), retired to a convent, where he lived two years longer. He was one of the most virtuous and able emperors of the East. There are extant from his pen scholia and other works on Homer.

Isaac II. ANGELUS, connected through his mother with the Comnenian emperors, became sovereign of the East in 1185, and reigned ten years. Isaac was a vicious and cowardly prince, and his reign was a period of war and tumult. He was dethroned, blinded, and imprisoned by his brother Alexius in 1195. Eight years later he was restored to the throne, and reigned for a period of six months, when he was again dethroned, and soon after he died in prison.

Isabella of Castile, queen of Spain, born on 23d April 1451, was the daughter of John II., king of Castile and Leon, and in 1469 married Ferdinand V., surnamed 'the Catholic,' king of Aragon. See FERDINAND.

Isabella II. (MARIA ISABEL LUISA), ex-queen of Spain, the elder daughter of Ferdinand VII. See SPAIN.

Isabey. JEAN BAPTISTE, French portrait-painter, was born at Nancy on 11th April 1767, and studied under David. He painted portraits of several of the notabilities of the Revolution, as Saint-Just, Barrère, Collot d'Herbois, and others. Afterwards he became court-painter to Napoleon, and painted him and most of his generals, and important events in his life. After Napoleon's fall Isabey worked for the Bourbon sovereigns. He excelled also as a miniature-painter and as a painter on porcelain. His 'Isabey's Boat' (1796), 'Review of Troops by the First Consul' (1804), 'Members of the Congress of Vienna' (1815), and 'Staircase of the Paris Museum,' a water-colour (1817), are his most important compositions apart from portraits. He died at Paris, 18th April 1855. His son, Eugène (1804-86), was a clever historical painter.

Isæus is, like Wordsworth's cuckoo, 'a voice, a mystery,' for, though we have ten of the fifty speeches he composed, we know absolutely nothing of the facts of his life, except that he pursued the profession of speech-writer in Athens, and that his first speech was composed in 389 B.C. and his last in 353 B.C., so that he may be said to have lived from the time of the Peloponnesian war to that of Philip's supremacy. Isæus did not compose political speeches, or speeches to be delivered in public suits, but exclusively speeches for private suits.

His strength as a lawyer lay in his power of dealing with cases of inheritance, and it is fortunately those of his speeches which deal with this branch of Attic law that have survived to our times. To the student of Aryan institutions and of comparative law, as well as to the student of Attic law, they are invaluable. To the general reader they are less interesting, for the very nature of the cases in which they were delivered—disputes as to *uccum* and *tanu*—forbade any very lofty flights of eloquence. On the other hand, the functions which he discharged in the history of Greek oratory as a branch of literature were of the utmost importance, and explain the fact that he was included in the 'canon' of the ten great Greek orators. It was through Isæus that the change from the older style of Lysias to the new school of which Demosthenes is the greatest representative was effected. He imitated Lysias, and was himself the teacher of Demosthenes. It will be remembered that Demosthenes' first speeches were those delivered by him in his efforts to recover his inheritance, the branch of the law in which Isæus was acknowledged master. The characteristics of the two schools between which Isæus was the connecting link are to be seen in the natural tones of Lysias contrasted with the technical skill of the professional orator which along with higher gifts marks Demosthenes. The importance of this contrast becomes apparent when it is remembered that the speech-writer or logographer was not allowed by Athenian law to speak himself on behalf of his client, but only to compose speeches to be delivered by his client. When speech-writing first became a profession and a branch of literature—i.e. about the beginning of the Peloponnesian war—there was a prejudice in the mind of the average Athenian jurymen against the use of speeches thus written, which made it desirable that the speech should have the appearance of being the speaker's own composition. In adapting his style to the character of his client for the time being Lysias was unrivalled. By the time of Demosthenes the practice of logography was so usual that attempts at disguise were less necessary; and the speech-writer might display all the technical skill of oratory without arousing suspicion. Isæus endeavours to imitate the unprofessional and innocent style of Lysias, but does not succeed in concealing the hoof of the advocate; his simplicity is exaggerated, his sentences have not the careless ease of Lysias, but an ungraceful negligence. At the same time we find in him the germs of that combination of practical utility and artistic beauty which was afterwards to mark the new school. Nor can it be doubted that Isæus surpasses Lysias, as he is himself surpassed by Demosthenes, in pure oratorical skill. Lysias is distinguished for simple colouring but graceful drawing, Isæus for careless drawing but deeper shade, brighter light, and greater wealth of colour. The *editio princeps* is that of Aldus (1513). The best edition and commentary (German) is that of Schömann (1831).

Isaiah (Heb. *Jeshaiab*), son of Amoz, first of the greater Hebrew prophets, was a citizen of Jerusalem, who came forward as prophet about 740 B.C. (probable death-year of King Uzziah), and exercised his office till at least the close of the century. The main object of his prophesying was his people, Israel, sunk in social unrighteousness and idolatry; the subject was his people's God, Jehovah, *called or sovereign in righteousness*, and, because there is nothing higher than righteousness, supreme over the whole world and its forces. From such a God to such people only punishment could pass, and the means for this was present in the great world-power of the day, the Assyrians, four of whose invasions of Palestine Isaiah predicted and lived to see. Be-

cause, however, Jehovah's honour and the existence of true religion upon earth were identified with the continuance of Israel's national history, Isaiah promised the survival of a *remnant*, the stock of an imperial nation in the latter days, and centre for a whole world converted to Jehovah. This *remnant* required a leader and a rallying-place; and it was on these two points that Isaiah's eloquence and hope reached their climax: that a great prince should arise in Judah—though sometimes he described the future without this personage—and that Zion, though closely besieged, should remain inviolate.

In the book of his name, the prophecies generally admitted to be Isaiah's do not lie in chronological order. They may be re-arranged according to the four invasions of Palestine: Tiglath-pileser's, 734-32; Salmanser's and Sargon's, 725-20; Sargon's, 711-10; Sennacherib's, 701. (1) In the prophecies held to be prior to the first invasion (ii.-x. 4; some add x. 5-34, and xvii. 1-14) Isaiah describes his call, arraigns both states of Israel, intimates their invasion, but with a different result for each. To north Israel he holds out no hope: in the worst that can happen to Judah, Zion shall stand, and David's dynasty survive in a prince, whose birth Isaiah predicts as almost immediate, whom he hails as a deliverer from the Assyrians, but his ascriptions to whom are applied by the New Testament and Christian theology to Jesus Christ. Tiglath-pileser retired taking only a small part of north Israel captive. (2) In prophecies of the next invasion (xxviii. and most probably x. 5-xi.) Isaiah repeated the doom of north Israel, and his word was vindicated by the fall of Samaria in 721 and captivity of the people. He warned Judah again, but defied the Assyrian to take Zion, and expanded his prospect of the coming prince and the glory of the nation. Hezekiah, his friend, was now on the throne, and their joint work of abolishing the idols may have begun. (3) About the invasion of 711-10 there is difficulty. Did it comprise Judah? Sayce, Cheyne, &c. say it did, and assign to it Isaiah, x. 5-34, xxvii., and xxxvi. 1, where they read *Sargon* for *Sennacherib*. But of an invasion of Judah by Sargon we have no direct evidence, and hence other critics (Driver, Robertson Smith, &c.) assign to this period only xx., xvi. 1-10, perhaps xvi. 13-14 (the rest of xv.-xvi. being earlier), and the events in xxxviii. and xxxix. (4) With 705—the revolt of Sargon's vassals against Sennacherib, his successor, and Sennacherib's preparations to reduce them—we reach the most fertile period of Isaiah's prophesying. In xxix.-xxxii. he denounces Jewish intrigues with Egypt, predicts the siege and deliverance of Zion, and promises to faith and sincerity a glorious future. In another set of oracles to foreign nations, not all dating from this time, xiv. 24-32, perhaps xvii. 12-14, xviii., xix., xxi., xxiii., he intimates to a number of tribes the futility of their resistance to Assyria, and affirms that only Zion shall stand. In 701 Sennacherib overran Judah, and seems to have been bought off by Hezekiah, only, however, to send back a corps under the Rab-shakeh to demand Zion's surrender. It was this corps whose sudden withdrawal, upon news of a great disaster to the main army at Pelusium, set Jerusalem free, and so gloriously vindicated Isaiah's word. His orations during these events are probably chap. i., describing the devastation of Judah; xvii., the panic and profligacy of the capital on the first appearance of the enemy; and xxxiii., the prophet's final triumph at the Assyrian withdrawal; with the detailed narrative of events, xxxvi. 2-xxxvii. After this triumph in 701 it is very uncertain that we have anything more from Isaiah, except it be the latter half of xix., which has been

called his 'swan-song.' Of his end we know nothing: a tradition exists that he was slain to death in the persecution of Manasseh (cf. Epistle to Hebrews, xi. 37; Genara, Jehamoth, 49 *b*, and Sanh. 103 *b*; Joseph, *Antiq.* x. 31).

There still remains a large portion of the Book of Isaiah, xiii.-xiv. 23, xxiv. xxvii., xxxiv., xxxv., and xl.-lxvi. The first doubts as to the authenticity of these were started by Aben-Ezra, and followed up by Koppe (1779), who suspected that xl.-lxvi. were of later date, and after him by an increasing, and now the main, body of critics on the Continent and in Britain—Gesenius, Hitzig, Knobel, Umbreit, Ewald, A. B. Davidson, Cheyne, Driver, Robertson Smith, Kuonen, Wellhausen, &c.; and to a less degree, Delitzsch, Bredenkamp, Orelli, &c. No critic of any eminence now claims all sixty chapters for Isaiah; and indeed the belief that they were all his could only have originated through the taking for granted that the title of chap. i. covers the whole book—an opinion falsified by the appearance of titles for some of the following chapters and their absence from others. None of the chapters in question, save xiii., claim to be Isaiah's, and that they are not his may be argued, apart from the uncertain and confusing testimony of style, vocabulary, &c., upon grounds of historical evidence. The circumstance and horizon of these prophecies are entirely different from those of the authentic oracles. Assyria is no more the dominant world-power, nor Zion the inviolate fortress of God. The Jews are not in their own land: they are either in exile or just returned. It is no more the repulse of the invader or the recovery of Zion from siege that is predicted; but the overthrow of the tyrant in his own land, the redemption of a captive people, the laying down of a highway for the return of exiles, the rebuilding of the city, and the resumption of worship. Exile is not foretold, nor the effort made to lift the imagination to it as certain. It is described as present: the people are addressed as in exile, their conscience is appealed to as the conscience of a people who have suffered and acknowledge their penalty. In the case of xl.-lxvi. there is an additional argument. In some of these chapters Cyrus, who appeared about 550 or more than a century after Isaiah's death, is not only named as the deliverer of the exiles, and described as existing in the flesh; but in a debate (chap. xli. ff.) about Jehovah's righteousness—i.e. his fidelity to his ancient promises of deliverance and his ability to perform them—Cyrus is presented both to Jew and heathen as a living proof that these promises are about to be fulfilled—which surely would have been an utterly vain proceeding, if Cyrus were not already there, visible to all men. This very definite evidence overbears not only the resemblances in style between xl. lxvi. and Isaiah's own oracles, but also such facts as that Isaiah foresaw the Babylonian captivity (xxxix.) or that he once wrote from the standpoint of a much larger exile than happened in his own day (xi.). It is quite possible, though incapable of proof, that the disputed prophecies contain fragments from Isaiah himself. That they contain at least pre-exilic fragments is more certain: lvi. 9 lvii. 11 implies that the Jewish state still exists, and bears traces of an origin in Palestine. By some lviii. ff., especially lxiii. lxvi., are held to be post-exilic. Originally in the Jewish canon the Book of Isaiah seems to have followed Ezekiel, a fact which seems to confirm the late date of at least parts of the book.

See Commentaries by Alexander (1817; new ed. 1875), Ewald, Delitzsch (trans. 1891), Orelli (trans. 1891), and the present writer (in 'Expositor's Bible,' 1891); Driver's *Isaiah: his Life and Times* (1888); Kennedy's *Unity of Isaiah* (1891); works by Cheyne (1870-95); and Matthew Arnold's two books on Isaiah.

Isambert, FRANÇOIS ANDRÉ, French lawyer, was born at Annay (Eure-et-Loire) on 30th November 1792. In 1818 he began to practise as an advocate at the Court of Cassation in Paris. Here he soon made a name as a political advocate, ranging himself in opposition to the Restoration government. About this time he greatly enhanced his reputation by publishing *Recueil Général des Anciennes Lois Françaises* (29 vols. 1821-33), *Traité du Droit Public et du Droit des Gens* (5 vols. 1823), and *Code Electoral et Municipal* (2d ed. 1831). He also interested himself actively in the condition of the liberated slaves in the French West Indian colonies. After the July revolution of 1830 he was elected councillor of the Court of Cassation and elected a member of the Chamber of Deputies. From this year down to 1848 Isambert belonged to the Constitutional opposition, signalling himself as a friend of liberty and an opponent of the Jesuits. The chief literary productions of the later part of his life are *Etat Religieux de la France et de l'Europe* (1843-44) and *Histoire de Justinien* (1856). His *Pandectes Françaises*, a collection of French laws, edicts, and ordinances, from 1789 onwards, was left unfinished. Isambert died at Paris on 13th April 1857.

Isandula, or ISANDHLWANA, in the north-east of Natal, on the left bank of the Buffalo River, 110 miles N. by W. of Durban. There, on 22d January 1879, the British camp, comprising four companies of the 24th, with a native contingent, under Colonels Durnford and Pulleine, was surprised by 18,000 Zulus in Lord Chelmsford's absence and almost annihilated. The British loss exceeded 800, that of the Zulus 2000.

Isar, or ISER, a river of Bavaria, rises in the Tyrol, north-east of Innsbruck, and flows 220 miles, generally in a north and north-east direction, till it falls into the Danube near Deggendorf. Munich and Landshut are on the banks of Isar, rolling rapidly; Hohenlinden (q.v.) is 20 miles away. In the first part of its course it is an impetuous mountain-torrent; and even after it leaves the Alps it has many rapids and islands. Large quantities of wood are floated down the Isar from the mountains. Area of its drainage basin, 3545 sq. m.

Isauria, in ancient geography, a district of Asia Minor, occupying the summit and northern slopes of Mount Taurus. The people were stern and savage, like their native mountains, and occupied themselves principally in robbery and piracy. At length their depredations and those of their neighbours, the Cilicians, became so formidable that the Roman proconsul, P. Servilius, chased them into their mountain fastnesses and coerced them into submission in 76 B.C., for which exploit he acquired the surname Isauricus. Nevertheless the Isaurians were not subdued. Pompey, in warring against the Mediterranean pirates, drove them off the sea; but they soon returned again. Indeed so far was their power from having been broken that they conquered the Cilicians, and remained the terror of the neighbouring states down to the 4th century. In the reign of the Emperor Gallienus (253-268) there even arose among this savage folk a rival emperor, Trebellianus, who, however, was finally crushed. This same people also gave two emperors to Byzantium, Zeno I. (474-491) and Leo III. (718-741); the descendants of the latter ruled over the empire of the East for three generations. From the 5th century onwards the Isaurians gradually disappear from history.

Ischia (the ancient *Enuria* and *Pitheusa*), an island on the north side of the entrance to the Bay of Naples, 6 miles from the mainland. Area, 26 sq. m.; pop. (1881) 22,170. Ischia is a favourite

place of summer resort, being noted for the excellence of its warm mineral waters, the great richness of its soil, the exquisite flavour of its fruits and wines, and the enchanting character of its scenery. Its highest point is the volcanic Monte Epomeo, 2608 feet, the last outbreak of which occurred in 1302. In 1881 Casamicciola was nearly destroyed by two earthquake shocks. A still more dreadful catastrophe befell it on September 28, 1883, when the town was utterly overwhelmed, only four or five buildings being left standing, and four or five thousand persons lost their lives. The inhabitants grow fruits, wine, and olive-oil, and carry on fishing. Chief towns: Ischia (2741), a bishop's seat; Casamicciola (3063); and Torio (3157). See Johnston-Lavis, *The Earthquakes of Ischia* (Naples, 1886).

Ischl, a town of Upper Austria, surrounded on all sides by gardens, is finely situated, 1536 feet above sea-level, on the river Traun, amid magnificent Alpine scenery, 33 miles E. by S. of Salzburg. It is the chief town of the district called the Salzkammergut (q.v.). The situation of Ischl, and the saline baths, established in 1822, attract 4000 or 5000 visitors annually, including the Austrian royal family, who have built a villa. About 8000 tons of salt are manufactured here every year in the salt-works, opened in 1571. Pop. 2124. See *Ischl und seine Umgehung* (7th ed. 1885).

Isghem, a town of Belgium, 10 miles by rail N. by W. of Courtrai, has linen and lace manufactures, and a pop. of 9520.

Iseo, LAKE (*Lacus Sabinus*), a lake of Northern Italy, situated between the provinces of Bergamo and Brescia. Length, 12½ miles; maximum breadth, 3½ miles; area, 24 sq. m. It contains two small islands, and is fed by the Oglio, a tributary of the Po.

Isère, a department in the south-east of France, round which on the north and west flows the river Rhone. It was formed out of the ancient province of Dauphiné. Area, 3200 sq. m.; pop. (1872) 575,784; (1886) 581,680; (1891) 572,145. The surface is level in the north-west, but becomes mountainous and picturesque in the east and south-east. Mont du Midi, on the south-eastern border, rises to 13,088 feet. The chief river, besides the Rhone, is its left-hand tributary, the Isère, which, rising in the Alps at an altitude of 7540 feet, flows south-westwards to join the Rhone above Valence, after a total course of 180 miles (102 navigable). The products include wheat, wine, stone fruits, medicinal plants, and hemp. Cheese is made; and silkworms are reared. The department is rich in mineral products; iron, coal, and turf are worked, and to a less extent marble, slates, and gypsum. The industrial activity is considerable, particularly in the manufacture of iron and steel goods, gloves, silk stuffs, cloth, linen, paper, straw-hats, liqueur (Chartreuse), &c. The department contains four arrondissements, Grenoble, La Tour-du-Pin, St Marcellin, and Vienne; capital, Grenoble.

Iserlohn, a manufacturing town of Prussian Westphalia, is situated on a tributary of the Ruhr, 14 miles S.E. of Dortmund. The industry is chiefly directed to the manufacture of hardware, especially of brass and bronze articles. The calamine mines are celebrated. In the neighbourhood is the Deelen stalactite cave, 292 yards long, discovered in 1868. Pop. (1875) 16,868; (1895) 24,722.

Isernia (anc. *Esernia*), a town of Italy, in the Apennines, 52 miles N. of Naples. It is surrounded by walls, built on the cyclopean Samnite remains. Among other antiquities is a subterranean aqueduct. The town, much injured in 1805 by an earthquake, is the seat of a bishop. Pop. 7678.

Ishmael, the son of Abraham, by Hagar, the Egyptian handmaid of his wife Sarah. In the story of his life given in Genesis he was driven at fifteen from his father's house along with his mother, and grew up to manhood in the southern wilderness a famous archer. He became the progenitor of a great nation, and the character of the Arabs was supposed to have been foretold in Gen. xvi. 12. Mohammed asserted his descent from Ishmael, and the Mohammedan doctors declare that Ishmael, and not Isaac, was offered up in sacrifice—transferring the scene of this act from Moriah in Palestine to Mount Arafat near Mecca.

Ishpeming, a city of Michigan, 15 miles W. of Marquette on Lake Superior, and 392 miles N. of Chicago by rail. Large quantities of iron ore (a red hematite) are quarried close by, and the town possesses foundries, blast-furnaces, &c. Many of the miners are Scandinavians. Pop. 6840.

Isidore of Seville (ISIDORIUS HISPALENSIS), one of the most distinguished ecclesiastics at the beginning of the 7th century. He was born most probably about 560, either at Seville or at Carthagera, where his father, Severianus, was prefect, and he succeeded Leander as Archbishop of Seville in the year 600. Two of his brothers, Fulgentius and Leander, were, like himself, bishops, the first of Carthagera, the second Isidore's successor in the see of Seville. The episcopate of Isidore is rendered notable by the two half-ecclesiastical, half-civil councils at Seville in 618 or 619, and at Toledo in 633, which were held under his presidency, and the canons of which may almost be said to have formed the basis of the constitutional law of the Spanish kingdoms, both for church and for state, down to the great constitutional changes of the 15th century. He also collected with the same object all the decrees of councils and other church laws anterior to his time. His death, which occurred in 636, forms one of the most remarkable scenes in early Christian history. When he became sensible of the approach of death he summoned his flock to his bedside, exhorted them to mutual forbearance and charity, prayed their forgiveness for all his own shortcomings in his duty, and directed all his property to be distributed among the poor. At the eighth Council of Toledo in 653, the epithet *Egyptius* was applied to him, and later Pope Benedict XIV. permitted the office of St Isidore to be recited in the universal church with the antiphon 'O doctor optime,' and the gospel 'Vos estis sal terra.'

Isidore was a voluminous and learned writer in a Latin ornate rather than pure, and his personal character stands high for its simplicity and goodness. His writings include *Etymologies* or *Origines* treating of the whole cycle of the sciences, and showing wide reading in the Greek and Latin classics; *Libri Differentiarum sive de propriitate sermonum*; *Præsentia in Libros Vet. et Nov. Test.*; *Questiones tunc de Nov. quam de Vet. Test.*; *De Fide Catholica contra Judæos*; *Sententiarum Libri iii.*; *De Ecclesiasticis officiis*; *Synonyma de laudatione animæ peccatricis*; *Regula Monachorum*; *De Natura Rerum Liber*; *Chronicon*; *Historia de regibus Gothorum, Wandalorum, et Suevozum*; and *De Viris Illustribus Liber*.

The standard edition is that of Arevalo (7 vols. 4to, Rome, 1797-1803), reprinted by the Abbé Migne in his *Patrologia Latina* (lxxxi, lxxxiv, l), together with the *Collectio Canonum* ascribed to Isidore. Vols. lxxxv, lxxxvi, of the latter also contain the *Liturgia Mozarabica secundum Regnum Bæti Isidori*.

Isidorian Decretals. See CANON LAW.

Isinglass (supposed to be derived from the German *Hausablase*, 'bladder of the sturgeon'), the *Ichthyopoda* (*ichthys*, 'a fish'; *lolla*, 'glue') of the classical and scientific writers, was formerly obtained only from the common sturgeon (*Acipenser sturio*), and consisted of the dried air bladder of

the animal. The necessities of modern commerce have, however, led to the discovery that the same part in many other fishes forms good isinglass; and instead of Russia, as formerly, being almost the only producing country, large quantities are now brought to Britain from South America (chiefly from Maranhão), some from the East Indies, New York, and Canada. The commercial varieties of this material are numerous; and besides them others are occasionally met with, as the *Mauilla*, in thin cakes; the *Para*, which is the most remarkable of all, resembling grapes of a reddish-brown colour, growing from a straight thick stem, being the dried ova of the *Sudis gigas*, a large fish common in the mouths of the Amazon. An inferior kind is also made of cod-sounds and sole-skins, sufficiently good, however, to be used in fining beer and other liquids. Isinglass, strictly speaking, is not Gelatine (q.v.), but a good gelatine-yielding tissue, its value being enhanced by the ease with which it is abstracted from the membrane when compared with the complicated process necessary for separating and purifying the gelatine from the skins, &c. of other animals. When separated, however, the substances are identical in composition, and, if pure, are undistinguishable from each other.

ISIS, the name applied by Leland, Camden, &c., and in the form *Ysa* by Higden (14th century), to the upper part of the river Thames (q.v.). For a long discussion of the origin of the name—a classicised form perhaps of the Celtic *uisgr*, 'water'—see *Notes and Queries* for 1882-84.

ISIS, an Egyptian goddess. The deities of ancient Egypt might be male or female, but in neither case could the Egyptian worshipper conceive a deity as existing in isolation; to every deity of either sex there must be a counterpart of the other sex. It was to this notion that the goddess Isis owed her origin; she was the counterpart of Osiris, and this fact is expressed in the statement that she was at once wife and sister of Osiris. But in all such cases the counterpart remained a much less important personage than the original deity, whether male or female. The mythological functions of Isis accordingly will be found to be subordinated, at any rate in their oldest forms, to the myth of Osiris. In the next place, as the child is the reproduction of its parents, for the father lives again in his children, the son was to the Egyptian in a way identical with the father, and when, as in the case of the gods, the mother was but the counterpart of the father, the identity of the child with the parents was yet more complete. In other words, as a child is impossible without parents, so it is impossible for a father to exist without a child of which he is the father. Hence we find that the deities of ancient Egypt are grouped in triads or triunities. Father, mother, and child cannot be conceived except in relation to each other (the terms are correlative); yet, though identical and inseparable, they are nevertheless distinct. The deity who completed the triad in the case of Osiris and Isis was their son Horus. In order to understand the position occupied by this triad in the circle of ancient Egyptian deities it is necessary to premise that Egypt was no exception to the laws which govern the growth of all political communities. All states which are larger than mere city states have become larger by the amalgamation or *synoikismos* of smaller unities. The smaller states out of which Egypt as a political whole was formed still continued after the political unification of the country by Menes to exist as administrative districts, even when Egypt became part of the Roman empire, just as the boundaries of a modern English county in many cases represent the frontiers of ancient states.

In Egypt these divisions are generally known under their Greek name as 'nomes.' Each nome, while yet an independent state, possessed its own local deities. When, however, they were brought under one government a pantheon was necessarily formed, and the order of precedence amongst the various local deities arranged. Practically, however, each nome continued to regard its own deity or trinity as really the supreme god, unless it could succeed in identifying its own deity with some other member of the national hierarchy. This explains on the one hand the statement of Herodotus (ii. 42) that no gods were worshipped universally in Egypt except Osiris and Isis, and on the other hand it enables us to understand how it comes about that Isis was worshipped as Mut at Thebes, as Sekhet at Bubastis, and as Hathor or Athor at Dendera, as Sothis, the dog-star, and as the planet Venus. It also explains why Osiris, originally the local deity of Abydos, came to be universally worshipped throughout Egypt. Osiris undoubtedly owed his elevation in the Egyptian pantheon to the fact that he was identified with Ra, the sun or sun-god. In chapter 17 of the *Book of the Dead* this identification is expressed in the explicit terms, 'Ra, the soul of Osiris, and Osiris, the soul of Ra.'

We may now proceed to the mythological functions of Isis. As being the counterpart, the sister of Osiris, she was the child of the same parents as her brother and husband—of Seb (or, as some transliterate it, Qeb), the earth, and Nut, the sky. The beneficent course of the sun across the sky is terminated by his murder at the hands of his brother Set. But though the sun dies to-night, to-morrow there lives another sun, who is different and yet the same, as the child is different from and yet the same as his father. This is Horus, who avenges the death of his father Osiris. Within the limits of this myth place was found for Isis as the faithful wife of Osiris, who recovered the body of her murdered husband, after it had been flung into the Nile by Set. Having concealed the body, Isis fled to her son Horus, and during her absence Set found the body and cut it into fourteen pieces, which he scattered. These Isis collected and buried in a stately tomb. The question at once presents itself, what was the original meaning of the mythological functions ascribed to Isis in the myth of Osiris? And we may conjecture that the answer is to be sought in the original local character of Egyptian deities, in the process of identification, or 'syncretism,' and in the ritual which grew out of it. Horus was originally the local god of Edfu; he may have been a solar deity, at anyrate he came to be regarded as the same, yet not the same, as the local solar deity of Abydos, Osiris. He was interpreted as the son of Osiris. But Horus was in conflict with Set; obviously, therefore, it must have been as the avenger of his father, Osiris, that Horus engaged in conflict with Set, though before Horus was brought into connection with Osiris no such story existed. Again, Horus, before he was identified as the son of Osiris, had a mother of his own, Hathor, the local deity of Dendera. By what process Horus, the god of Edfu, had come to be regarded as connected with the goddess of Dendera we do not know. But the connection was expressed in ritual by a religious procession from Dendera to Edfu. Accordingly, when Horus became the son of Osiris, and Athor in consequence was identified with Isis, the procession in which the image of Athor—i.e. Isis—visited Horus at Edfu required a mythological explanation. It was provided by the invention of the myth of Isis' flight to Horus after the death of Osiris. The dismemberment of Osiris and the collection of the members by Isis is apparently an invention to account for the phallic ceremonies, which survive to the present day in

Egypt. From this analysis of the myth of Isis and Osiris, it becomes apparent that the deities of ancient Egypt were not originally conceived in triads; but that, on the contrary, the trinity of the god was a later doctrine designed to explain the syncretism which resulted from the amalgamation of the various nomes and their deities. There is yet another mythological function ascribed to Isis which requires mention and explanation: she rocks the cradle of the infant Nile. To the Egyptian the conflict between the sun and the powers of darkness, in the heaven above, may have had its parallel on the earth beneath in the perennial conflict between the beneficent Nile with the sands of the desert. At anyrate, Osiris had the Nile as well as the sun for his emblem; and by a not unnatural confusion between Osiris and Horus, for Horus is Osiris in his youth, Isis was regarded as tending the infant Nile. Finally, we may dismiss Isis in Egypt by adding that she as Neith was regarded as the patron goddess of women, and presided over child-birth.

But we have yet to trace the fortunes of Isis in Greece and in Rome. As early as Herodotus (ii. 156) she was taken to be the same as the Greek Demeter—for no other reason apparently than that Demeter, like Isis, suffered a great loss. Only, it was her daughter, not her husband, that Demeter lost. This was, however, a trifle to stand in the way of a Greek resolved to identify his mythology with that of the oldest, the wisest, and most religious of mankind. After the time of Herodotus—probably, indeed, not until post-classical Greek times—on the ground that the wife of the sun must be the moon, Isis became a moon-goddess, and was identified by the Greeks with their moon-goddess Io. Again, as Athor, Isis was imagined to be the same as the Semitic Astarte and the Greek Aphrodite. When the attributes and powers of all these goddesses were ascribed by the (post-classical) Greeks to Isis it is easy to understand that in the Orphic mysteries Isis was the chief and most mysterious of all goddesses. Nor have we any difficulty in recognising that the Pans and Satyrs and the nursing of Astarte's children, &c. which appear in Greek accounts of Isis are borrowed from myths that really belong to Demeter, and are not Egyptian at all. Our two chief Greek authorities, Diodorus Siculus and Plutarch (*De Isid. et Osir.*), draw mainly upon one Hecateus, of the time of Alexander; and we may say generally that it is impossible to trace Isis as a figure in Greek mythology farther back than the age of Alexander.

It is in the Roman empire that Isis becomes a mythological figure of importance outside Egypt. The process of syncretism was carried further in her case than in that of any other deity. Every function ever attributed to any deity whatever was transferred to her, and the result is best stated in the words of the mysterious goddess herself to the Golden Ass of Apuleius (*Met.* xi. 241): 'I am the universal mother nature, mistress of all elements, first-born of the ages, supreme of goddesses, queen of names, ruler of the gods, sole manifestation of all gods and goddesses, whose glance makes awful silence in the shining heights of heaven, in the depths of the sea, and of the world beneath, whose unchanging being is worshipped under many forms, with many rites, and under various names, as mother of the gods, as the Cerepian Minerva, Paphian Venus, Dietynnian Diana, Stygian Proserpina, the ancient goddess Ceres, as Juno, Bellona, Hecate, Rhamnusia—but my true name is Queen Isis.' To this we may add the inscription mentioned by Proclus: 'I am that which is, has been, and shall be. My veil no one has lifted. The fruit I bore was the Sun.'

See Maspero, *Histoire Ancienne*; Le Page Renouf's *Hibbert Lectures* (1879); Sayce's *Herobotus*; Chantepie

de la Sausseye, *Lehrbuch der Religionsgeschichte* (v. 1887); Brugseh, *Religion und Mythologie der alten Ägypter* (i. 1884); R. Lepsius, *Ueber den ersten Ägyptischen Götterkreis* (1851); E. Lefebvre, *L'Étude de la Religion Égyptienne* (1886).

Iskanderoon. See SCANDEROON.

Isla. JOSÉ FRANCISCO DE, was born in 1703 at Vidanes, in north-western Spain. Early in life he joined the Jesuits, for some years was lecturer in philosophy and theology at Segovia, Santiago, and Pamplona, and became famous as a preacher, but still more as a humorist and satirist by his writings, especially his novel of *Friar Gerund*. Except Cervantes and Quevedo no man had a larger share of that peculiar grave humour which is one of the special products of Spain, and with him it seems to have been almost irrepresible. Even in *Youth Triumphant*, an account of a masque performed by the students of his own order at Salamanca in 1727, in honour of the canonisation of two young Jesuits, he could not altogether control his propensity to ridicule. The *Letters of Juan de la Encina*, written in 1732, on a pamphlet by a quack doctor at Segovia who had given him offence, are a good example of his style, but a more characteristic one is the *Dia Grande de Navarra*, a description of the ceremonial at Pamplona on the accession of Ferdinand VI. in 1746, which he wrote at the request of the local authorities. It is, in fact, an adroit caricature of the grandiloquence, pomposity, and inflated phrase usual on such occasions, but his artful flattery of provincial vanity and official self-importance blinded the eyes of the good Pamplonese, and they passed a vote of thanks to him, which he appealed to with an admirable assumption of injured innocence when the wits of Madrid charged him with the joke. He had a hearty contempt for shams and pretences of all sorts. *Friar Gerund* was aimed at the charlatanism of the popular preachers of the day, especially the preaching friars. The decline of culture produced uncritical audiences, and these again swarms of preachers who tried to get credit with the crowd for originality by tricks, mannerisms, and clap-trap. Isla's model, as he owned in his preface, was *Don Quixote*; what Cervantes had done with the sham chivalry and sentiment of the romances, he strove to do with the vulgar buffooneries of the pulpit, and he was almost equally successful. The first volume came out at Madrid in 1758, and in three days the whole edition of 1500 was sold off. From the king down everybody was delighted with it—everybody, that is, except the friars, for 'Fray Gerundio' at once became a nickname, and their congregations, they found, laughed at instead of with them. But the friars were a power, and at their instance the Inquisition stopped the publication of the book. A clandestine edition of vol. ii., with the imprint of Campazas, as well as a reprint of vol. i., came out in 1770, and another in 1787, but none with a license until 1813. Isla was struck down with paralysis in 1767 as he was obeying the edict expelling the Jesuits, but he insisted on sharing the lot of his comrades, and betook himself to Bologna, where he lived, cheerful and uncomplaining, in poverty and ill-health, until the end of 1781. A little before his death he wrote his translation of *Gil Blas*. A friend had urged him to assert their country's claim to a book that, as the French themselves acknowledged, had been stolen from Spain, but he objected that he was not David enough to attack such a Goliath as Le Sage, and that he had never read *Gil Blas*. But afterwards, having nothing to do, he took it up and translated it, and further amused himself with a preface in which he humoured his friend's patriotic idea in his own grave way, by a circumstantial story in the style of *Gerundio* and the *Dia Grande*, of how Le Sage

(who never was in Spain), being in the suite of the French ambassador at Madrid, met a certain Andalusian advocate who gave him the MS. of the novel. On his title-page he put, 'Stolen from Spain, and restored to its country and native language by a jealous Spaniard who will not allow his nation to be made game of;' words which sufficiently indicate his drift; but his gravity imposed upon the Comte de Neuchâteau of the French Academy, and provoked a serious refutation in 1818, to which Llorente replied in 1820; and the controversy, having that element of paradox which gives vitality to argument, still maintains a fitful existence. See LE SAGE.

The best edition of Isla's works is that in vol. xv. of the *Biblioteca de Autores Españoles*, giving *Fray Gerardo*, the *Cartas de Juan de la Encina*, the *Día Grande de Xacurca*, and a full collection of his delightful letters, but omitting his sermons and translations. The English translation of *Fray Gerardo* (1772), by Dr Warner (some say Dr Nugent), is somewhat abridged and a little vulgar in its attempts at the dialect of the Campos rustics, but on the whole pretty faithful.

Isla de Pinos. See PINOS, ISLA DE.

Islām. or ESIĀM (Arab.), the proper name of the Mohammedan religion; designating complete and entire submission of body and soul to God, his will and his service, as well as to all those articles of faith, commands, and ordinances revealed to and ordained by Mohammed the prophet. See MOHAMMEDANISM.

Islamabad. See CHITTAGONG.

Island (A.S. *igland*, *ig*, 'island,' and *land*. *Ig* is cognate with Icel. *ey*, Dan. *ø*, and ultimately with A.S. *ea*, Gothic *ahva*, and Lat. *agua*, all signifying 'a stream,' 'water.' The *s* in island crept in through confusion with Fr. *isle*, derived from Lat. *insula*, land surrounded by water. The larger masses of land surrounded by water, or parts of them, are Continents (q.v.), and the term island is usually restricted to the smaller. Since Australia has an area of over 3,000,000 sq. m., and (omitting Greenland, which is possibly an ice-bound archipelago) New Guinea, the next island in size, has only 303,000 sq. m., the distinction drawn between continents and islands in the restricted sense is more than verbal. There are few large islands. Borneo, indeed, is little inferior in size to New Guinea; but Madagascar and Sumatra are the only others with an area greater than 100,000 sq. m. Honshū (the main island of Japan) and Great Britain rank next, the latter being sixth in order of size if New Guinea is taken as first. The following table shows the relative mainland area of the largest islands.

Islands.	Area in sq. m.	I-lands.	Area in sq. m.
New Guinea	303,000	Iceland	39,800
Borneo	284,000	Mindanao	37,000
Madagascar	227,000	Ireland	32,000
Sumatra	165,000	Haiti	28,800
Honshū	186,500	Tasmania	26,200
Great Britain	83,700	Ceylon	24,700
Celebes	68,800	Nova Zembla (N. Island)	19,300
New Zealand (S. Island)	58,500	Tierra del Fuego	18,500
Java	48,400	Nova Zembla (S. Island)	15,700
Cuba	45,000	Formosa	15,000
New Zealand (N. Island)	44,500	Hainan	14,000
Newfoundland	41,200	Sicily	9,300
Luzon	40,900	Sardinia	9,200

Two classes of islands may be distinguished—continental and oceanic. *Continental Islands* are closely allied by the structure of their rocks to the nearest continental land, from which they are rarely far distant, although sometimes—as in the case of Madagascar and New Zealand—separated by depths exceeding 1000 fathoms. As a rule, continental islands lie to the south and east of the continent with which they are associated. The only exceptions to this rule are islands on

the continental shelf—i.e. separated by depths less than 100 fathoms, which have been cut off from the mainland in geologically recent times. With the exception of Madagascar and New Zealand, the separation of which is unusually complete, the plants and animals of continental islands are similar to those on the adjacent continent, and from the slight differences detected the period at which separation took place has sometimes been calculated. Groups of continental islands enclosing seas stretch from the south-east peninsula of each of the northern continents towards the nearest southern continent. The Greek Archipelago points from the Balkan Peninsula towards Africa, the West Indies run from Florida and Yucatan to South America, and the Eastern Archipelago extends from the Malay Peninsula to Australia. These archipelagoes represent mountainous tracts of continent which have subsided, or else irregular portions of the submarine plateaus which are undergoing elevation. Professor James Geikie points out in a paper (*Scot. Geog. Mag.*, February 1890) that in past geological epochs groups of great islands occupied the sites of the present continents, and he shows reason for believing that the evolution of continents by the incorporation of islands on the great world ridges is still going on, although accompanied by the formation of new islands through local erosive action on the coasts.

Oceanic Islands rise abruptly from great depths, and show no geological continuity with the continents. They appear above the surface either as (a) *Volcanic Islands*, usually rugged peaks or vast accumulations of lava nearly as precipitous below the surface as above, or as (b) *Coral Islands* (q.v.). Numerous submarine mountains have been discovered in different parts of the ocean, which only require moderate elevation or the deposition of sediment or coral growth to appear on the surface as islands. The fauna and flora of oceanic islands like those of Madagascar and New Zealand, which biologically resemble oceanic islands, differ widely from those of the continents, and present many features of unique interest, which have been worked out in detail by Wallace in his *Island Life*. See GEOGRAPHICAL DISTRIBUTION.

Continental islands have in historical times formed the cradles of great commercial nations, the insular position giving security, and the water border acting at once as a barrier to the less adventurous continental people and as a highway to the bolder islanders, whose closer contact with the sea makes them nations of sailors.—For Floating Islands, see that head; and for the 'Islands of the Blessed' and other fabulous islands, see ANTILLES, ATLANTIS, AVALON, BRENDAN, ELYSIUM, &c.

Islandshire, a part of Northumberland in England, embracing the Farne Islands, together with three parishes adjoining Berwick-on-Tweed (q.v.) and portions of two others. Area, 28,444 acres; pop. 3875. Till 1844 it formed a detached part of Durham county.

Islay, an island of Argyllshire, 13 miles W. of Kintyre, and $\frac{1}{2}$ mile SW. of Jura, from which it is separated by the Sound of Islay. Deeply indented on the south by Loch Indal (12 × 8 miles), Islay has a maximum length and breadth of 25 $\frac{1}{2}$ and 19 miles, and an area of 216 sq. m. It contains several small fresh-water lakes, and attains a height of 1441 feet. More than half the whole area is capable of cultivation, and great improvements have been effected in the way of road-making, draining, reclamation, &c. Dairy-farming, stock-raising, and whisky-distillation are leading industries; whilst slate, marble, iron, lead, and silver have been worked. In the course

of the century the old proprietors and the native tenantry have been largely superseded by newcomers. Islay has regular steamboat communication with Glasgow, and a telegraph was established in 1871. Pop. (1831) 14,982; (1891) 7335.

Isle of France. See MAURITIUS.

Isle of Man, Wight, &c. See MAX, WIGHT.

Isles, LORDS OF THE. See LORDS OF THE ISLES.

Isleworth, a Middlesex parish, on the left bank of the Thames, 12 miles WSW. of London. Here is Sion House, a seat of the Duke of Northumberland, the place where the crown was offered to Lady Jane Grey. Pop. 15,884.

Islington, a suburb of London, but so closely connected with it as to form part of it, is situated 2½ miles N. of St Paul's. Pop. (1861) 155,341; (1871) 213,778; (1891) 319,143. It is remarkable for the number of its religious, educational, and benevolent institutions. The Agricultural Hall (1861), where the great national cattle and horse shows are held, is capable of holding 50,000 people. In 1885 Islington was made a parliamentary borough. It returns four members to parliament, one member for each of its four divisions.

Ismail, a town and river-port in the Russian government of Bessarabia, stands on the north bank of the Kilia branch of the Danube, 48 miles from the mouth of that river. Formerly a Turkish fortress, it was taken and destroyed by Suwaroff in December 1790; came into possession of Russia in 1812; was assigned to Moldavia by the treaty of Paris, 1856, its fortifications being razed; and was transferred to Russia again by the Berlin Congress of 1878. It has an active trade in corn, wool, tallow, and hides. Pop. with the adjoining Tutchkoiff (1866) 31,779; (1897) 31,293.

Ismailia, a small town on Lake Timsah, through which the Suez Canal passes. It stands on the railway from Cairo to Suez and on the Sweet Water Canal. During the construction of the canal it was the headquarters of the work, having been founded in 1863, but it is now a place of only 1850 inhabitants.—The name Ismailia was also given to Gondokoro (q.v.) on the White Nile.

Ismailis, a Mohammedan sect. Like the rest of the Shi'ah, or party of Ali, they held that the dignity of Imâm, or head of the true faith, was inherent in the house of the Prophet and the line of Ali, the Prophet's cousin, son-in-law, and chosen lieutenant. They arose in Syria and Persia, taking their name from one Ismail, whom they regarded as the seventh and last of the Imâms, and who lived about 770 A.D. But the sect acquired its importance a century later from Abdallah al Kaddah, a Persian of Susiana, and son of Maimin. He was an oculist, a scholar, and an able juggler. The Ismailis had then no visible Imâm; indeed the Shi'ah lost its twelfth and last Imâm in the mysterious disappearance of Mohammed in 879 A.D. The idea of a 'Hidden Imâm,' destined to appear for the reformation of religion and of the world, thus became necessary for its existence. To undermine the whole empire, to prepare a great revolution and overthrow Islam was Abdallah's desire. His instrument was the faith in a 'Hidden Imâm,' or 'Mahdi,' 'Guided or Inspired One,' styled by Abdallah the seventh prophet, Mohammed having been the sixth. His many widely-spread dus or missionaries taught their converts that this coming deliverer had opened up the true and mystic meaning of the Koran. The teaching of all previous prophets was abrogated by him. Converts passing through their nine stages of instruction learned to deny all positive religion. Prayers, tithes, pil-

grimages, legal purity, and other religious observances were shown to have meaning and use for only the blinded crowd. A Demingus was declared to be the world's maker. The resurrection, the end of the world, final judgment, and rewards and punishments were mere allegories. The universe was eternal. Finally, belief was made absolutely free. Mohammed, the Chief, Hidden Imâm, Mahdi, or Seventh Prophet, son of Ismail, was, after all, not to appear but in his doctrine taught by his disciples and apostles; and the duty of all believers was to bring the world's sovereignty into the hands of these. Abdallah's son, Ahmed, succeeded him as Grand Master of the Ismailian Society. In his time a Babylonian peasant, Hamdan Karmat, joined it, became a missionary, a leader, and at length about 891 proclaimed a communistic system. For two centuries the Karmathians were the scourge of Islam and the East. An Ismailian missionary among the Berbers of Constantine called the people to arms in Ali's name. Obeidallah, a descendant of Abdallah al Kaddah, and Grand Master of the Ismailian Society, was put at the head of the revolution, before which the Aghlabite (809) and the Edrisite powers quickly fell; and, calling himself a scion of Ali, by Fatima the Prophet's daughter, was declared Calif and Mahdi. The rise of his dynasty, which is called the Fatimite, is the most remarkable example in history of the power of religious enthusiasm led by conscious imposture. Egypt (970) and Syria were added to its empire. The Karmathians recognised it and paid it tribute. Miserably decayed, it was supplanted in Egypt by Saladin in 1171. See also MAHDI.

Isma'il Pasha, Khedive of Egypt (q.v.) from 1863 to 1879.

Isobars. See METEOROLOGY.

Isochronism (Gr. *isos*, 'equal'; *chronos*, 'time'). A pendulum is isochronous when its vibrations are performed in equal times, whether these vibrations be large or small; but it can only possess this property by being constrained to move in a cycloidal arc. See CYCLOID.

Isoclinal Strata. See GEOLOGY, MOUNTAINS, STRATIFICATION.

Isocrates, the Athenian, who was born 436 B.C. and died 338 B.C., represents the perfection of 'epideictic' oratory—i.e. oratory in which form and literary finish count for everything, and matter for very little. Oratory, as a department of literature, was in Athens the outcome of that growth of litigiousness and development of the law-courts which characterised Athens from about the beginning of the Peloponnesian wars. The consequent necessity under which every Athenian was of being able to defend himself in a court of law first fostered the rise of a class of men—the Sophists—who professed to teach the art of argument, even to the extent of making the worse appear the better cause; and next, as the literary taste of Athenian juries increased, fostered the rise of a class who professed to teach the art of literary form, and who taught by example rather than precept. Hence 'epideictic' oratory, show-speeches. Such teachers of rhetoric have existed in other countries, but at no place and in no age have they reached the artistic excellence of Isocrates. This is partly due to the fact that, owing to the peculiar circumstances just explained, teachers of rhetoric in Athens at this time could gain the ear of the public, whilst elsewhere and at other times the teacher's audience has consisted of his pupils, and he has lacked the stimulus and the corrective of competent criticism. But though the hour had come, it might have sounded in vain had not the man been there. A brief summary of Isocrates' life will show that

nature had designed him for his work. If his speeches are deficient in practicality to an extent that has irritated Niebuhr for instance, it is because Isocrates was himself so utterly impractical. The son of a prosperous flute-maker, Isocrates received an excellent education, and in his youth heard the show-speeches made at Athens by the earliest epideictic orator, Gorgias. He also listened to the lectures of the philosopher Prodicus, and joined the circle of Socrates, and he only coquetted with philosophy, and though in the *Phaedrus* of Plato Socrates expresses the highest expectations of him, Isocrates abandoned philosophy. He then took to speech-writing as a profession, but he had none of the talents required in the composition of speeches having such a practical object as that of winning a case in a law-court. After trying his hand at six such speeches (402-393 B.C.) he abandoned logography. If he failed in writing practical speeches to be delivered by others, he was still less adapted by nature to deliver his own speeches himself and follow a political career; his voice was too feeble, and he was much too nervous. Other people since Isocrates having failed in other pursuits have betaken themselves to schoolmastering, but Isocrates deserves the credit of having been the first to discover this resource. About 390 B.C. he set up as a teacher of oratory, though he did indeed profess, in the speech which served as his prospectus (*Against the Sophists*), to give a general practical education. In his prospectus he was careful to distinguish himself from such shallow pretenders as the Sophists on the one hand, and on the other from such impractical teachers as philosophers. This sample of his skill as an artist in words, though it drew from Plato (*Euthydemus*, 301, D) some contemptuous animalversions on the little knowledge of certain persons who cultivate the domain intermediate between philosophy and politics, succeeded in drawing to him pupils who subsequently became distinguished, statesmen such as Timotheus and Laodamas, historians such as Ephorus and Theopompus, orators such as Isæus, Lycurgus, Eschines, and Hyperides. Pupils paid him 1000 drachmæ, and were put by him through a course of three or four years' duration. He himself composed model speeches for them, such as the *Panegyricus* (about 380 B.C.) and the *Platæicus* (373), and corrected the oratorical exercises composed by them. But he also wrote speeches intended to be practical: one of them, the *Archidæicus* (365 B.C.), may actually have been composed for and delivered by the Spartan king, Archidamus, but the majority, for instance the *Symmachæicus* (357 or 355 B.C.), the *Areopagitæicus* (about 354 B.C.), the *Panathenæicus* (342-339), and the letters to Philip of Macedon, were not designed to be delivered but to be circulated and read; they are in fact the earliest political pamphlets known. As a politician, or rather a would-be politician, Isocrates has only one idea, and that an utterly impracticable one—to unite all Greeks together in a joint attack upon the common foe, Persia. The practical commentary on this ridiculous Pan-Hellenistic panacea was the destruction of Greek freedom on the field of Charonea by the very Philip to whom Isocrates looked to make his nostrum effective. 'That dishonest victory,' in the words of Milton, 'killed with report that old man eloquent.' Isocrates did indeed die shortly after the news of the battle at the age of ninety-four, but it may be doubted whether it was the news that killed the schoolmaster. Unpractical Isocrates certainly was. Alexander conquered Asia in less time than it took Isocrates to write a single speech (the *Panegyricus*). But it was this very characteristic which made the oratory of Isocrates what it is. And Milton's tribute to him may serve to remind us that, in the

opinion of all competent judges, for melody, artistic merit, perfection of form and literary finish, Isocrates stands unrivalled. He has of course the defects of his qualities. His work may be finished, but it is undeniably laboured. He may have melody, but it is apt to become monotonous. He is always smooth, even where he ought to be stormy. Such perfection of form as he attained could only be produced by an artist who was willing to sacrifice everything else to it, and Isocrates by nature did readily incline to do so. A few obvious generalities and a few moral sentiments were all that he required in the way of matter for a speech; indeed for many speeches. The result is that having read one of his speeches you have read all. The truths of morality are indeed eternal, but they will not bear eternal repetition. Had but one of his speeches survived, his poverty of thought would never have been discovered, but fate with cruel kindness has preserved nearly everything he ever wrote. But if Isocrates is too beautiful to be absolutely perfect himself, we must not forget that to appreciate his services to Greek literature we must not consider him apart from the history of Greek oratory. He demonstrated once and for all, and at precisely the time when the demonstration was necessary, that prose as well as poetry may have an artistic beauty, may have rhythm, flow, and melody of its own. It was worth a lifetime's labour to effect this; and if it was only in Demosthenes that this outward beauty came to be wedded with nobler and with manlier qualities, let us remember that it were as vain to expect the fruit without the blossom as to imagine that we could have had Demosthenes without Isocrates.

The first edition was printed at Milan in 1493. The best edition of the text is that in the Teubner series. There are excellent English notes on the *Demonæicus* and *Panegyricus* by J. E. Sandys, German notes by Rauchenstein on the latter and the *Areopagitæicus*. There is an English translation by Freere (1894 *et seq.*).

Isodynamic, Isoclinic, and Isogonic Lines (Gr. *isos*, 'equal'; *dynamis*, 'force'; *klinô*, 'I bend'; *gonia*, 'an angle'), or lines of equal force, equal inclination, and equal declination, are three systems of lines, which being laid down on maps represent the magnetism of the globe as exhibited at the earth's surface in three classes of phenomena, the varying intensity of the force, the varying dip or inclination of the needle, and its varying declination from the true meridian. See MAGNETISM.

Isola Bella, ISOLA MADRE. See BORROMEAN ISLANDS.

Isola Grossa, or ISOLA LUNGA (Great or Long Island), a long, narrow island, 27 miles by 3, running parallel to the coast of Dalmatia, over against Zara. It belongs to Austria. Pop. 12,000.

Isomerism (from the Greek word *isomêrês*, 'composed of equal parts'), the relation between chemical compounds which are identical in their ultimate or percentage composition, but present differences in their chemical properties. Isomeric compounds, or *isomerides*, are divisible into metameric compounds, or *mutamerides*, and polymeric compounds, or *polymerides*.

In all metameric compounds the molecular weight is the same, while in all polymeric compounds the molecular weights are simple multiples of the molecular weight of the lowest member of the group. As an illustration of metameric compounds, propionic acid, C_3H_5COOH , acetate of methyl, CH_3COOCH_3 , and formic ether, $HCOOC_2H_5$, may be taken. Their rational formulae, which express their probable constitution, are perfectly distinct, yet they all have the same percentage composition, the same empirical formula, $C_3H_6O_2$, and the same molecular weight (74).

As an illustration of polymerides, the hydro-carbons homologous with olefiant gas may be taken. Olefiant gas is represented by the formula C_2H_4 , propylene by C_3H_6 , butylene by C_4H_8 , amylene by C_5H_{10} . These substances have the same percentage composition, but different molecular weights.

The carbohydrates, which are represented by the general formula $C_nH_{2n}O_n$, present well-marked examples of isomerism. Thus, cellulose, $C_6H_{10}O_5$, starch, $C_6H_{10}O_5$, and gum, $C_6H_{10}O_5$, are metameric; while grape-sugar, $C_6H_{12}O_6$, possesses the same percentage composition, but twice as high a molecular weight, as lactic acid, $C_3H_6O_3$, and the same percentage composition, but three times as high a molecular weight, as acetic acid, $C_2H_4O_2$; hence the three last-named substances are polymeric.

The most recent researches have brought to light the existence of several special varieties of isomerism. A *tautomeric* body is one in which the reaction to some reagents is as if certain hydrogen atoms were in one place in the molecule, while to others it is as if the hydrogen occupied a different position; and a tautomeric body may be *desammeric* when it can be prepared in recognisably different forms, differing from one another in the position of these wandering hydrogens. *Allotomeric* bodies have a similar chemical structure, but the geometrical symmetry is different, as in the following case (in which the symbol X stands for the group COOH):



The question of geometrically symmetrical or asymmetrical arrangement of atoms in a molecule has become, in the hands of Wislicenus and others, one of considerable importance in reference to isomerism. Quite possibly the allotropic modifications of some of the elements (see ALLOTROPY) are really isomeric differences of arrangement of the atoms within the molecule (q.v.). See also AROMATIC SERIES and CHEMISTRY (Vol. III, p. 152).

Isomorphism (derived from the Greek words *isos*, 'equal,' and *morphe*, 'form') strictly signifies similarity of form, but it is now restricted by chemists to those substances which are not only similar in their crystalline form, but are also analogous in their chemical composition. The diamond, C, magnetic oxide of iron, $FeO.Fe_2O_3$, and potash-alum, $K_2SO_4.Al_2(SO_4)_3.24H_2O$, all crystallise in octahedra, but there is obviously no analogy in the chemical composition of these substances; on the other hand, the spinelle ruby, $MgO.Al_2O_3$, magnetic oxide of iron, $FeO.Fe_2O_3$, and chrome ore, $FeO.Cr_2O_3$, not only crystallise in octahedra, but (as their formulae show) are also analogous in their chemical composition. Hence the members of the latter group, not the former, are truly isomorphous in the restricted sense. As further examples we may quote the elements arsenic, antimony, and tellurium; the chloride, bromide, iodide, and fluoride of potassium; the sesquioxides of aluminium, iron, chromium, and manganese; and for additional lists refer to Miller's *Chemical Physics*. In most cases, as Mitscherlich (to whom we owe most of our knowledge of this subject) showed, the chemical composition of substances that correspond in form is analogous; and that chemist further endeavoured to prove that crystalline form is independent of the chemical nature of the atoms, and that it is determined solely by their grouping and relative positions; the same number of atoms combined in the same way always producing, according to him, the same crystalline form. The coincidence of similarity in

crystalline form with similarity in atomic arrangement is the most important generalisation yet arrived at in the science of crystallography; and in chemistry it has been of essential service in facilitating the classification of compounds, and to some extent in determining the combining numbers or atomic weights of the elementary bodies.

Isopoda (Gr., 'equal-footed'), an order of higher Crustaceans in the division with unstalked eyes. The body is usually flattened, and the first pair of abdominal legs form a lid overlapping the others, which generally bear gills. They are mostly marine, but the wood-lice are terrestrial; they live mainly on decaying animal matter, but many are parasitic. The genus *Tanais* seems ancestral and primitive; *Asellus* is very common, both in fresh and salt water; the griddle (*Limnoria*) bores into wharf-posts and ship-sides; *Idotea* includes the largest forms with adaptive colours and sometimes phosphorescence; the family Bopyridæ are parasitic on other Crustaceans, and have very small males; the family Egidæ includes many 'fish-lice,' some of the parasitic Cymothoidæ are first male and then female. The Oniscoidæ are terrestrial, and feed on decaying vegetable matter; they are familiarly known as 'wood-lice,' 'sow-bugs,' 'pill-bugs,' 'slaters,' of which *Oniscus*, *Porcellio*, and *Armadillo* are common genera. See CRUSTACEA, FISH-LICE, WOOD-LICE.

Isothermal Lines. See TEMPERATURE.

Isotropism, physical homogeneity or amorphism; identity of elastic forces of propagation of vibration (light, heat, sound), or identity of susceptibility to magnetisation, in all directions.

Ispahân, properly ISFAHÂN, a famous city of Persia, capital of the province of Irak-Ajemi, and formerly capital of the entire country, is situated on the Zenderud, in an extensive and fertile plain, 226 miles S. of Tehran. The river, here 600 feet broad, is crossed by three noble bridges, one of them 1000 feet in length, with 34 arches, but now sadly in decay. Groves, orchards, avenues, and cultivated fields surround the city for miles; but the permanent beauty of the vicinity only serves to make the contrast all the more striking between the former splendour of the city and its present ruinous condition. Miles of street are now almost tenantless, and many of the palaces are deserted and rapidly falling to decay. The suburb Julia, on the southern bank of the river, once a flourishing Armenian settlement of 30,000 inhabitants, is now little better than a mass of ruins, since most of the Armenians have migrated to India. Ispahân, however, is still an important city and the seat of extensive manufactures, including all sorts of woven fabrics, from rich gold brocades and figured velvets to common calicoes. Trinkets and ornamental goods in great variety, with firearms, sword-blades, glass, and earthenware, are also manufactured. Of late years, too, Ispahân has shown considerable signs of improvement; many of its edifices have been rebuilt; rice, an important article of commerce, is now largely cultivated in the neighbourhood. Pop. estimated at 60,000.

Ispahân was a trading town of importance, and the capital of Irak, under the califs of Bagdad. It was taken by Timur in 1387, when 70,000 of the inhabitants are said to have been massacred. During the 17th century, under Shah-Abbas the Great, it became the capital of Persia, and reached the climax of its prosperity. Its walls were then 24 miles in circuit, and it is said to have had between 600,000 and 1,000,000 inhabitants. It was then the emporium of the Asiatic world; the merchandise of all nations enriched its bazaars, and ambassadors from Europe and the East crowded

its court. In 1722 it was devastated by the Afghans, and some time afterwards the seat of government was transferred to Tehran (q.v.). The importance of the place is likely to rise through the opening of the Karun River, since the main road leading from Mohammera to the interior of Persia will pass Ispahan. Ispahan is besides the religious centre of Persia, as the Imam Djunaa (high-priest) residing here is looked upon as the greatest ecclesiastical dignitary of the Shiite world.

Israel. KINGDOM OF. See JEWS.

Israëls. JOSEF, genre-painter, was born at Groningen in 1824. He studied at Amsterdam under Pfeneman and Krusenman, and in Paris under Picot and Henri Scheffer. In 1855 his 'William, Prince of Orange, opposing the Decree of the King of Spain' attracted attention in the Exposition Universelle. But this work was almost the only effort of the painter in the direction of historical art; for he soon turned to scenes from humble life, and settling at Katwijk near Leyden he devoted himself to the portrayal of the fisher-folk, sending to the Salon of 1857 his 'Children of the Sea' and his 'Evening on the Shore.' In 1867 his celebrated 'Interior of the Orphan Asylum at Katwijk' gained for him a third-class medal and the ribbon of the Legion of Honour; and eight years later he was awarded the cross and a first-class medal. More recently he has resided at The Hague, working indefatigably, and producing a long series of genre-pictures in oils and water-colours, presenting, usually in its pathetic aspects, the life of the humbler classes of Holland. At first his work was somewhat violent in colour, but gradually it has become subdued, harmonious, and lovely; his management of the restricted tonality which he has adopted shows the most accomplished artistic skill; and his handling is large, vigorous, and unlaboured. Among his chief pictures may be named 'The Sewing-school at Katwijk' (1881), 'Silent Company' (1882), 'Fine Weather' (1883), and 'The Struggle for Life' (1883). He is also favourably known as an etcher by 'Old Mary,' 'The Cradle,' 'The Mother,' 'The Fisherman,' and other plates very simple, direct, and painter-like in their method. See a monograph by Net-scher, with etchings by Steelink (French trans. by Zileken, Amsterdam).

Issik-kul (Kirkiz, 'warm water'), a lake in central Asia, in the Russian province of Semiryetchensk, situated, at an elevation of 5000 feet above sea-level, between the Terskei Ala-tan range on the south and the Kungei Ala-tan on the north. It measures 112 miles long, 38 miles broad, and covers an area of 1980 sq. m. Its water is very salt, but full of fish, especially carp. Notwithstanding the fact that it receives forty or more rivers, its surface falls permanently at the rate of 8 or 9 inches a year.

Issoire (anc. *Issiodorum*), a town in the French department of Puy-de-Dôme, near the confluence of the Couze and Allier, 21 miles by rail S.E. of Clermont Ferrand. Pop. 6051. The town and its people were treated with savage fury by both parties during the religious wars after the Reformation (1574-77).

Issoudun, a town in the French department of Indre, 72 miles S. of Orleans by rail, has manufactures of parchment, cloth, agricultural instruments, &c., and quarries of lithographic stone. Pop. (1872) 11,913; (1886) 12,697; (1891) 11,431.

Issue, in Law, means the point of fact in dispute which is submitted to a jury.

Issus, anciently, a seaport on a gulf of the same name in Cilicia, Asia Minor, celebrated for

the victory which Alexander the Great obtained here over Darius (333 B.C.), by which the camp and treasure and family of Darius fell into his hands.

Issy, a village in the French department of Seine, half a mile SW. from Paris, with which it is connected by a tramway, possesses a seminary, a retreat for old men, a castle, and manufactures of waxcloth, chemicals, &c. Pop. (1886) 12,080. Here on 3d July 1815 Bliicher defeated Davout. In 1870-71, during the siege of Paris by the Germans, the fort of Issy suffered severely from the artillery fire. It has since been re-erected, and now forms part of the south-west defences of Paris.

Istakhr, or STAKHR, an ancient city of Persia, built near Persepolis (q.v.).

Istamboul. See CONSTANTINOPEL.

Isthmus, in Geography, a narrow neck of land joining two larger portions, as the Isthmus of Suez and the Isthmus of Panama. The name was often employed by the ancients without any addition to designate the Isthmus of Corinth, joining the Peloponnesus to continental Hellas. Here were celebrated the Isthmian Games, one of the four great national festivals of Greece. See ATHLETIC SPORTS.

Istria, an Austrian margraviate, forming a peninsula in the north-east corner of the Adriatic Sea, between the Gulf of Trieste and the Gulf of Fiume or Quarnero. Although a mountainous land, often swept by the sirocco and bora winds, it yields excellent olive oil and wine. Area, with the adjacent islands, 1812 sq. m.; pop. (1880) 292,000; (1885) 299,911, many of whom are engaged in seafaring life. Capital, Rovigno.—For Dora d'Istria, see GHKA.

Itacolomite, a schistose quartzite, containing scales of mica, talc, and chlorite, which are often so arranged as to give a certain flexibility to the rock (*flexible sandstone*). In Brazil and the south-eastern states of North America itacolomite is the matrix in which diamonds are found.

Italian Architecture. This term is usually limited to the style practised by the Italian architects of the 15th, 16th, and 17th centuries, and since adopted in every country in Europe. The style originated in a revival of the ancient architecture of Rome. Although Gothic architecture had been practised in Italy during the 13th and 14th centuries, it had never been thoroughly naturalised. The Italians always showed a preference for the round arch over the pointed northern form; and even in the buildings they erected in the pointed style there is a certain simplicity and largeness of parts indicative of a classic feeling. As early as 1350 Giovanni Pisano, in the beautiful sculpture of the pulpit in the Baptistery at Pisa, showed a return to the ancient models. Arnolfo di Cambio planned the cathedral of Florence (1290-1300), and in his design proposed a great dome (a remarkably Roman feature) over the crossing of the nave and transept. This he did not live to complete; but he prepared the way for Brunelleschi (q.v.), who went to Rome to study the ancient buildings there, at that time neglected and hardly known to the Italians themselves, and ultimately, notwithstanding great opposition, succeeded in carrying out the construction of the dome as it now stands. From this time the revival of Roman architecture went on rapidly. It was encouraged by the popes and other princes of Italy; and the invention of the printing-press soon spread a knowledge of the works of the Italian architects over Europe. At first the Roman mouldings and ornaments only were copied and applied to the

existing forms. As the ancient style became better understood its general principles were gradually adopted, until at length the Modern Italian style was formed. This style may be defined as ancient Roman architecture applied to the forms and requirements of modern buildings. It has been admirably applied to domestic, but it has never been so successfully used in ecclesiastical edifices.

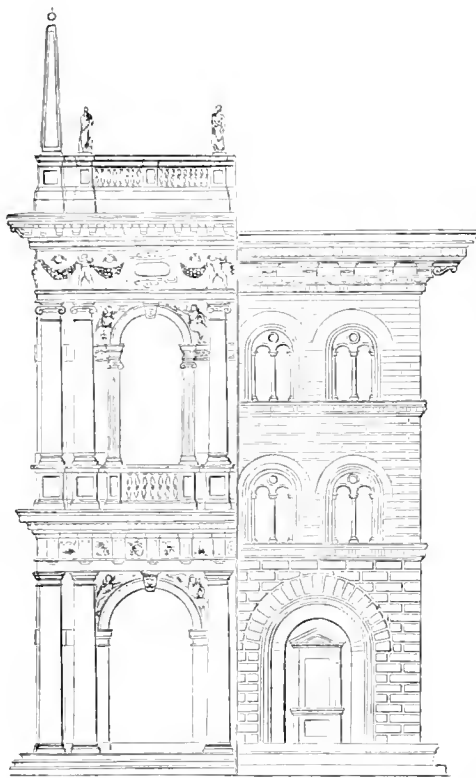

Library of St Mark's, Venice, by Sansovino. Ricardi Palace, Florence, by Michelozzo.

The domes of the Italian churches render the interiors of these buildings very impressive, and are a feature, for the introduction of which into the west of Europe we are indebted to this style; but the facades of the churches are broken up into stories, and want the unity of a Gothic front.

Italian architecture is divided into three styles or schools, according to the places where it was practised—viz. the Florentine, Roman, and Venetian. The Florentine buildings are massive and grand in effect; they are indebted to ancient Roman art chiefly for details, the outlines being the same as those of the older buildings, designed to suit the requirements of the locality. Florence being a turbulent city, every man who had anything to lose had literally to make his house his castle. Accordingly, the basement floor is massively built with large blocks of stone, and the windows are small and plain. The Roman school naturally resembles more closely the ancient Roman buildings so numerous in that city—pilasters, arcades, &c. being freely used. In Rome the plan of including two or more stories in one order of columns or pilasters with their entablature, having an attic or low story above, first originated, and was afterwards extensively, but, as already explained, not successfully applied to churches.

The Venetian style is, as might be expected in a city long accustomed to elegant palaces, the most ornate and picturesque of the Italian schools. Venice is crowded with specimens of all kinds from the earliest to the latest Renaissance, and retains its individuality of style from first to last. Each story is marked by a separate tier of columns or pilasters with their entablature; the windows are arched and ornamented with columns, and the spandrels commonly filled with figures. The outline is varied in form, and is usually finished with a balustrade, broken by pedestals, and crowned with sculptured figures. It is from this most picturesque of the styles of the Italian Renaissance that the other countries of Europe derived their peculiar forms. See RENAISSANCE, ELIZABETHAN, PALLADIO.

Italy. The kingdom of Italy comprises the central of the three great peninsulas of southern Europe (excepting the small republic of San Marino, q.v.) together with Sicily, Sardinia, and some smaller islands. Knit to the solid mass of central Europe by the Apennines, the peninsula projects south-eastward into the Mediterranean like a magnet, drawing to itself in ancient times the lordship and commerce of the whole sea, and serving as the avenue by which the culture of the East was carried into northern and western Europe. At the Strait of Otranto Italy approaches within less than 50 miles of Albania. The boundaries of the peninsula are on the W. and S. that portion of the Mediterranean known as the Tyrrhenian Sea, and on the E. the Adriatic; on the N. the Alps stretch from the head of the Adriatic to the Riviera, and almost without a break shut in the kingdom from Austro-Hungary, Switzerland, and France. The peninsula itself extends from 46° 40' 12" N. lat. (Monte Trugnoni in the Carnian Alps) to the southernmost point of Calabria, an unnamed headland in 37° 54' 54" N. lat., or 24' farther south than Cape Spartivento. The extreme eastern point is the Cape of Otranto, 18° 30' 37" E. long., and the western Monte Tabor, 6° 33' 7" E. Its greatest length in a direct line is 710 miles; the breadth ranges from 351 miles in the north to about 20 between the Gulfs of Sta Eufemia and Squillace, but in most places is about 90 or 100 miles. The seaboard of the peninsula extends to 2272 miles, that of the islands to 1944 miles; in 1890 the frontier with France was returned at 307 miles, with Switzerland at 407 miles, and with Austria at 466 miles.

The area of the kingdom of Italy was formerly given officially as 114,416 sq. m., but the data on which this estimate was based were known to be inexact. Strelbitsky, in his *Superficie de l'Europe* (1882), made the area 111,410 sq. m.; his calculations were revised by the Italian Military Geographical Institute in 1884, and the total area of the kingdom was still further reduced to 110,657 sq. m., made up as follows: Continental and peninsular Italy, with the small islands embraced in its administration, 91,422 sq. m.; Sicily and the islands administratively dependent on it, 9939 sq. m.; Sardinia and the islets near it, 9296 sq. m. These are the official figures for the entire kingdom; but as yet no detailed survey has been accomplished, and the areas given for the provinces in the table below are those obtained by Strelbitsky's calculations. At the first general census of the kingdom, in 1871, the population was 25,801,151. The table gives the population actually present at the census of December 31, 1881 (density 257 per sq. m.); in 1895 the estimated population was 30,913,670. The number of foreigners in Italy at the time of the census of 1881 was 59,956, including 16,992 Austrians, 12,101 Swiss, 10,781 French, and 7302 British. The Italian population includes in Piedmont about 120,000 of French, and some 3000

of Teutonic origin, in Southern Italy at least 60,000 of Albanian and 20,000 of Greek origin, and in Sardinia 7000 or 8000 of Spanish origin. (A list of

Provinces and Compartimenti	Area in Sq. Miles	Population in 1881	Est. Pop. in 1888
1. Alessandria.....	1,906	729,710	891,462
2. Cuneo.....	2,892	635,400	677,536
3. Novara.....	2,554	675,926	732,359
4. Turin.....	4,637	1,029,214	1,085,759
PIEMONTE.....	11,389	3,070,250	3,297,157
5. Genoa.....	1,649	760,122	810,562
6. Porto Maurizio.....	498	132,251	136,738
LIIGURIA.....	2,087	892,373	947,300
7. Bergamo.....	1,092	399,775	430,582
8. Brescia.....	1,815	471,568	501,531
9. Como.....	1,080	515,050	565,411
10. Cremona.....	687	302,138	324,204
11. Mantua.....	911	295,728	321,872
12. Milan.....	1,213	1,114,991	1,228,218
13. Pavia.....	1,312	469,831	513,983
14. Sondrio.....	1,206	129,534	128,172
LOMBARDY.....	9,316	3,689,615	4,013,973
15. Belluno.....	1,292	174,149	194,093
16. Udine.....	797	397,762	437,656
17. Ravenna.....	613	217,700	239,579
18. Treviso.....	952	375,794	421,500
19. Udine.....	2,556	501,745	555,911
20. Venice.....	733	356,798	383,247
21. Verona.....	1,225	394,065	428,556
22. Vicenza.....	1,075	396,349	411,496
VENETIA.....	9,276	2,814,173	3,101,807
23. Bologna.....	1,332	464,879	497,213
24. Ferrara.....	1,014	230,807	250,430
25. Forlì.....	768	251,110	274,942
26. Modena.....	994	279,254	303,541
27. Parma.....	1,278	267,306	285,790
28. Piacenza.....	909	226,717	242,843
29. Ravenna.....	779	218,559	232,482
30. Reggio Emilia.....	888	244,959	266,146
EMILIA.....	8,012	2,183,391	2,352,497
31. Arezzo.....	1,273	238,744	259,018
32. Florence.....	2,230	790,776	859,226
33. Grosseto.....	1,771	114,295	127,123
34. Ligorio.....	133	121,612	126,798
35. Lucca.....	544	284,484	309,480
36. Massa and Carrara.....	648	199,469	186,221
37. Pisa.....	1,206	283,563	310,321
38. Siena.....	1,477	205,926	222,164
TOSCANA.....	9,291	2,208,869	2,391,291
39. Ancona.....	788	267,338	290,367
40. Ascoli Piceno.....	770	209,185	223,477
41. Macerata.....	1,072	239,713	261,071
42. Pesaro and Urbino.....	1,167	223,943	240,982
MARCHE.....	3,797	939,279	1,021,997
43. Perugia (Umbria).....	3,558	572,069	624,039
44. Rome.....	4,699	963,472	982,581
45. Aquila degli Abruzzi.....	2,558	353,927	389,117
46. Campobasso.....	1,705	265,434	291,087
47. Chieti.....	1,194	343,948	372,815
48. Teramo.....	1,110	254,896	281,332
ABRUZZI and MOLISE.....	6,567	1,317,215	1,434,351
49. Avellino.....	1,171	392,619	432,949
50. Benevento.....	837	238,425	259,015
51. Caserta.....	2,699	714,131	779,782
52. Naples.....	336	1,001,245	1,060,032
53. Salerno.....	1,958	559,157	597,031
CAMPANIA.....	6,322	2,896,577	3,128,809
54. Bari.....	2,285	679,499	731,728
55. Foggia.....	2,584	356,267	381,731
56. Lecce.....	3,048	553,298	600,905
APULIA.....	7,920	1,589,064	1,734,287
57. Potenza (Basilicata).....	3,398	521,501	556,309
58. Canuzaro.....	1,398	433,975	461,269
59. Conza.....	2,586	431,185	462,699
60. Reggio di Calabria.....	1,227	372,723	405,913
CALABRIA.....	5,311	1,257,883	1,359,872
61. Calabria.....	1,270	296,379	297,762
62. Calabria.....	1,924	563,157	623,922
63. Calabria.....	1,166	312,487	352,778
64. Messina.....	1,246	469,924	511,315
65. Palermo.....	1,985	609,151	771,070
66. Syracuse.....	1,140	341,526	389,596
67. Trapani.....	939	283,977	317,175
SICILY.....	9,361	2,977,991	3,295,688
68. Cagliari.....	5,284	429,635	449,414
69. Sassari.....	3,077	261,367	286,171
SARDINIA.....	9,296	682,002	735,588
Total.....	111,410	28,459,628	30,947,306

the pretty numerous places in the Neapolitan and Sicilian provinces where Albanian, an Italianised Modern Greek, Gallo-Italic, Provençal, and Illyrian are still in use as 'linguistic islands,' will be found in a paper contributed by Prince Lucien Bonaparte to the Philological Society, March 1890.) The estimated population at the end of 1889 (see table) was 30,947,306; but this is based solely on the difference between births and deaths, and takes no account of emigration. Within the eight years 1882-89, 791,404 persons left Italy for different parts of America, as many as 113,066 emigrating in 1889 alone. In 1888 the United States received 47,856; Argentina, 75,029; Brazil, 104,353. Of the 1881 population 501 in every 1000 were males. In the accompanying table the old *compartimenti* or groups of provinces are retained for convenience, although they are no longer recognised as administrative divisions. The area is nearly that of Great Britain and Ireland; the population about four-fifths that of the United Kingdom at the same date. To the kingdom proper must be added Italy's colonial possession in Africa. This consists of the territories of Assab and Massowah (q.v.), on the Red Sea, Keren and Asmara in Abyssinia, and the Dahlak archipelago, which embrace a total area of nearly 4000 sq. m., and were united into a colony bearing the name of Eritrea in 1889. Moreover, Italy established a protectorate for some distance inland from Massowah, and along the coast from Ras Kasar (18° 2' N.) to beyond Assab, and till the disastrous events of 1896 claimed to have established a protectorate over Abyssinia.

The towns with a population of over 100,000 in 1881 were Naples, 463,172; Milan, 295,543; Rome, 273,268; Turin, 230,183; Palermo, 205,712; Genoa, 138,081; Florence, 134,992; Venice, 129,445; and Bologna, 103,998. In 1895 the estimated populations were: Naples, 523,000; Rome, 453,000; Milan, 433,000; Turin, 336,000; Palermo, 277,000; Genoa, 217,000; Florence, 200,000; Venice, 150,000; Messina, 147,000; Bologna, 142,000. The seat of government was at Turin from 1861 to 1865, then at Florence till 1870, since which date Rome has been the capital of the kingdom.

Physical Features.—The configuration of continental Italy (for the islands, see SARDINIA and SICILY) may be easily explained; in the peninsular portion it is determined mainly by the great chain of the Apennines. It is usual with geographers to divide the country into Northern, Central, and Southern Italy, the middle section generally being taken to extend between Spezia and Cape Circello on the west coast and Rimini and Monte Gargano on the east coast. This division, however, especially as regards its southern boundary, is purely arbitrary, and it will be more convenient in this article, while retaining the terms commonly in use, to describe the country under the two divisions into which physically it falls—the great plain of Northern Italy, and the generally mountainous peninsula to the south.

On the northern frontier the Alps sweep round in a mighty arc from Nice to Trieste, running out in places into Piedmont, Lombardy, and Venice. For the most part they rise steep and abrupt, except where their wall is pierced by long, deep valleys; and some of the loftiest peaks in the system, including Mont Blanc and Monte Rosa, belong to this mountain-girdle. The highest mountain entirely within the kingdom is Gran Paradiso (13,652 feet), the culminating point of the Graian Alps, in Piedmont. Between the Alps and the Apennines spreads the broad fertile Lombardo-Venetian plain, a nearly level country, which differs altogether in character from the peninsula to the south, and for a long period was politically distinct from it. Most of this great

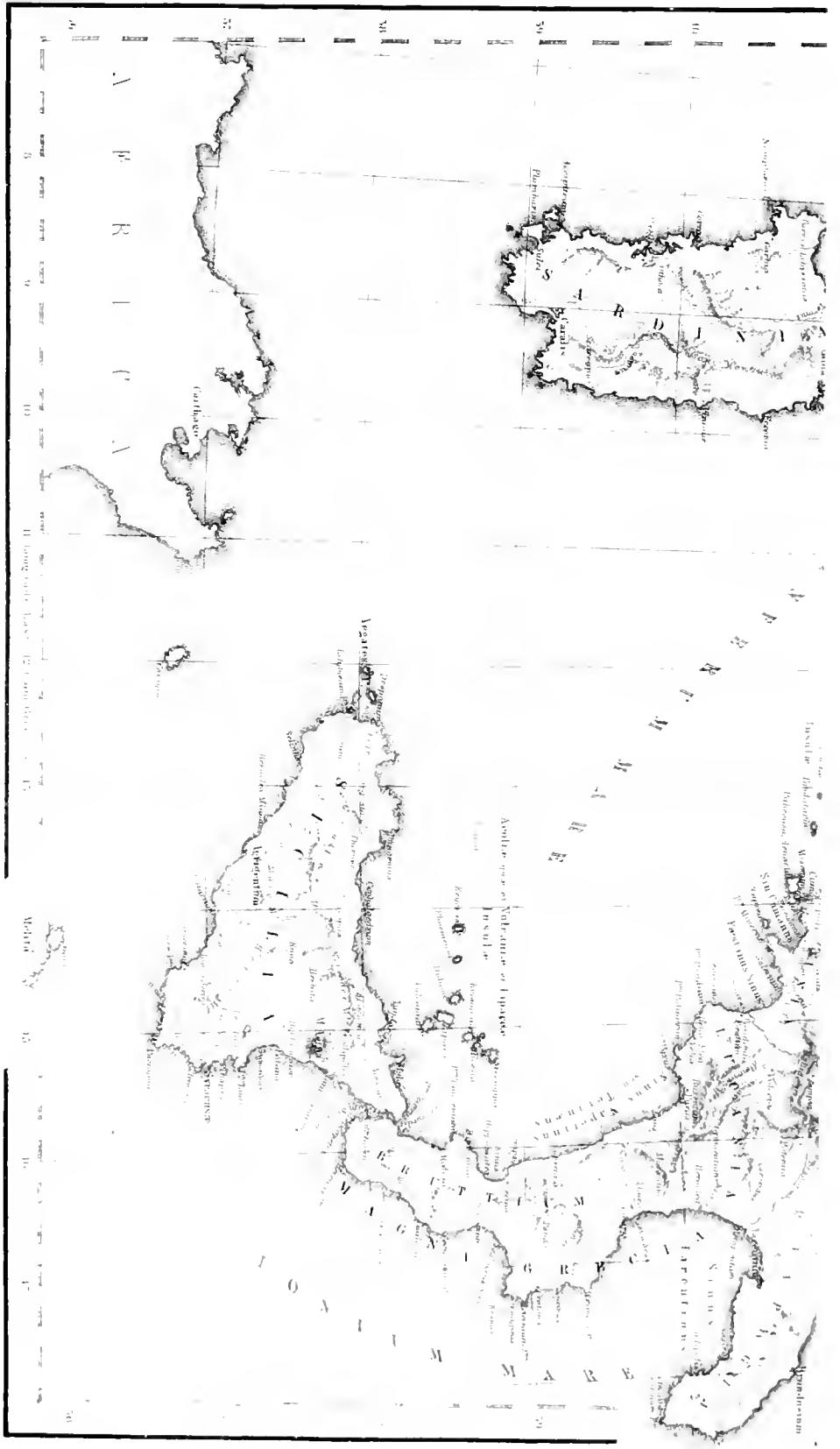

W & R HAMBLETT, LIMITED, LONDON & EDINBURGH



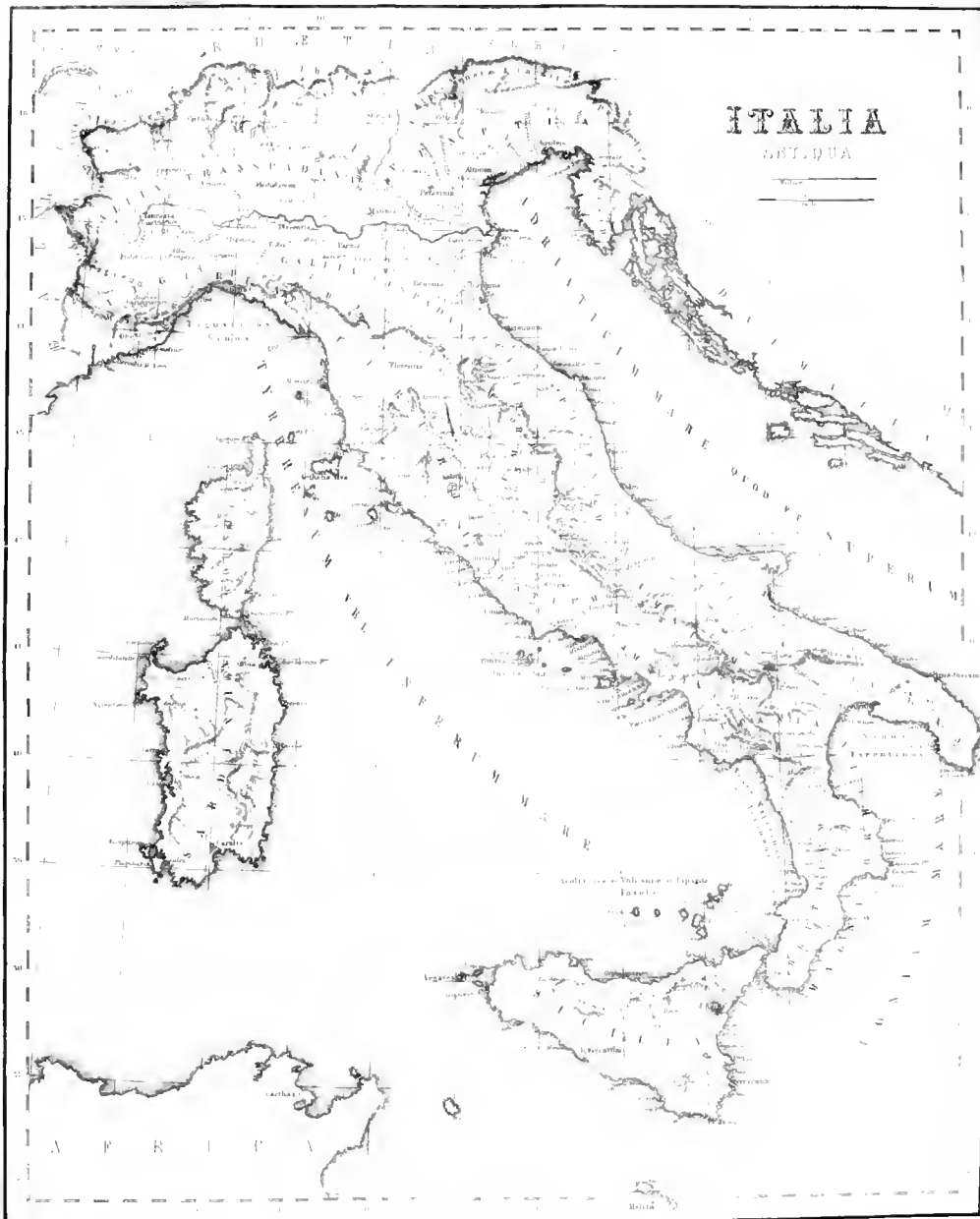

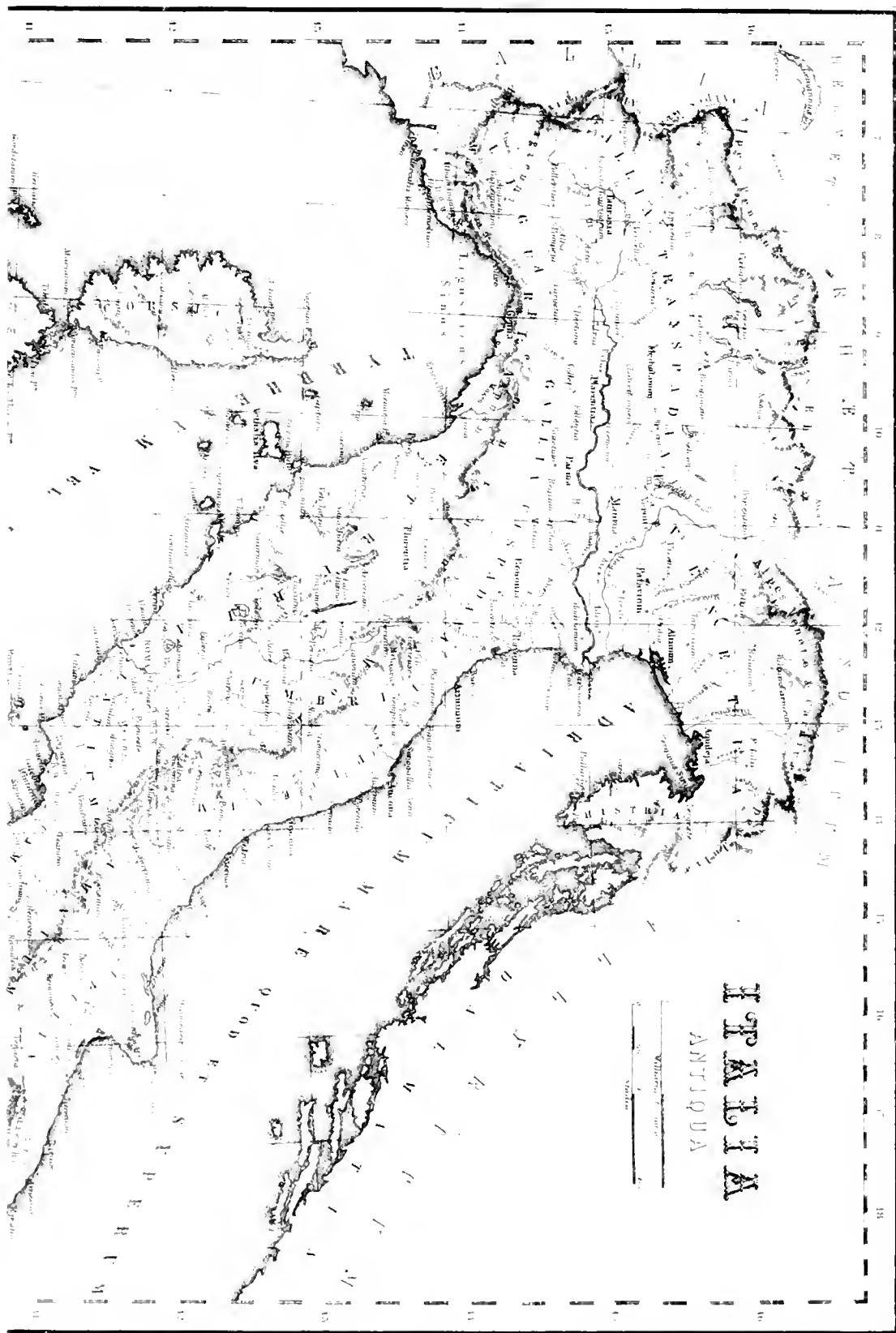

HAWAIIAN ISLANDS

Scale: 1:100,000
Nautical Miles: 0 1 2 3 4 5 6 7 8 9 10
Statute Miles: 0 1 2 3 4 5 6 7 8 9 10

alluvial tract, which fills nearly the whole of Northern Italy, belongs to the basin of the Po; it is irrigated by numerous streams and canals, and is one of the most fruitful and flourishing districts of Italy. The principal rivers are fed from the Alpine lakes; and the Po (q.v.), which descends from Monte Viso, on the western frontier, and, as it sweeps across the plain, receives the contributions of numerous important streams, ranks for its volume of water among the notable rivers of Europe. It is navigable for 320 out of its 420 miles, and several of its tributaries are also navigable. The Adige, which is connected with the Po by canals, is also, although much more rapid, navigable in its lower course, and so is the Brenta; the other streams that pour down through the Venetian plain are mostly mountain-torrents. The lakes of Northern Italy belong to a different class from those of the peninsula. Many of the Po's tributaries spread out at the foot of the Alps into considerable bodies of water, among which are the Lago di Garda (127 sq. m.), Lago Maggiore (81), and Como (58). These lakes are all remarkable for their depth; Maggiore is reported to have a depth of 1158 feet, Como 1358, and Garda 1916 feet. From Rimini to the Gulf of Trieste the coast is flat and marshy from the overflow of the rivers, and fringed, both north and south of the muddy delta of the Po, for long distances by lagoons. These lagoons are in general separated from the sea by only a narrow strip of sand, with openings at intervals, and contain some important harbours, such as Venice and Chioggia. On the opposite coast, along the Riviera, from Nice to Spezia, the sunny, rugged mountains come close to the water's edge, the only considerable portions of level ground occurring at the mouths of valleys. The Apennines shut out this district from the rest of Northern Italy, and from their proximity there are no large streams along the coast here. The geology of the north and west of Northern Italy is that of the Alps (q.v.). In the basin of the Po there are vast moraines left by the glaciers of the Glacial Period; and the isolated Monti Berici and Euganean Hills, in the plain north of the Adige, are of volcanic origin.

In the peninsula the Apennines are the most important feature. The chain, after stretching across from the Gulf of Genoa to the Adriatic, turns and runs down in a broad, irregular mass to the extremity of Calabria, but does not extend into the 'heel' towards Otranto. Its highest point before it makes its bend is Monte Cimone (7110 feet); but the mean elevation is only some 5200 feet, and the principal summits of the range occur in Central Italy. Here it no longer presents a continuous ridge, but is broken into mountain-masses and short ranges, marching in a roughly parallel direction, and separated by extensive upland valleys. The limestone rocks of the Apennines, rugged and cleft, fill the interior of the country with picturesque mountain-scenery, which becomes wilder as the chain stretches farther south, and in the Neapolitan highlands exhibits a savage grandeur, that is softened somewhat by the fertile 'red earth,' formed from the disintegrated limestone. In Central Italy the main chain follows the Adriatic side, and its eastern slope is the steeper; the western is less abrupt, and contains numerous valleys. The culminating peak of the Apennines is Monte Corno (9577 feet), in the great mountain-mass called Gran Sasso d'Italia. The bold promontory of Monte Gargano (once an island) does not belong to the Apennine system. The Neapolitan Apennines fill the rest of the peninsula, crossing over to the west coast, and running close upon the sea again, as in Northern Italy; but the system properly ends with Monte Pollino (7376), where the

Calabrian peninsula begins; for here the limestone, except at long intervals, gives place to granite, gneiss, and crystalline schists—to reappear, however, in the mountains of Sicily, which may be looked upon as a continuation of the range (for the geology, see APENNINES). On the west side of the peninsula, between the main chain and the sea, a volcanic tract extends from the isolated trachytic cone of Monte Amiata (5689), in Tuscany, to the Monti Laziali, and as far south as Vesuvius (4206), the only volcano still active. The entire Campanian plain, the Roman Campagna, and the country round Viterbo are mainly of volcanic origin; and throughout this tract are a number of small lakes occupying crater-shaped basins. The only volcanic peak east of the main chain is Monte Vulture (4364), somewhat farther north than Vesuvius. To the volcanic centres within the peninsula may be added Etna in Sicily, and Stromboli in the Lipari Islands. Tuscany is a hilly country, which seldom rises into mountains. Farther south the Roman plain, the Pontine Marshes, and the fertile Campanian plain are connected, with unimportant breaks; but on the east side of the Apennines the only plain is that of Apulia, which rises into undulating downs, and, in the peninsula to the north-east of the Gulf of Taranto, into low, barren hills of Pliocene formation. North of Apulia stretches of vine-clad hills occupy the country between the mountains and the Adriatic, until the lowlands of Northern Italy are reached.

The rivers of the peninsula present a striking contrast to those of the northern plains. Here are no such inexhaustible reservoirs as in the lakes and snowfields of the Alps, nor is the rainfall of importance save in the winter months; so that even the larger lowland rivers, except the Tiber, fall considerably in summer, and in the south what are torrents after heavy rains often in the dry season disappear altogether. The chief rivers of the peninsula flow into the Tyrrhenian Sea; but only the Tiber (for 90 miles) and, to a less extent, the Arno (66 miles), Volturno, and Garigliano are navigable. The lakes of the peninsula are either crater-lakes, such as that of Bolsena (45 sq. m.), or occupy troughs among the mountains. To the latter class belongs Trasimeno or the Lago di Perugia (52 sq. m.); Fucino or Celano, which was a larger lake, has been drained, and is now cultivated. The coast along the Adriatic extends unbroken, except where the Gargano promontory forms the Gulf of Manfredonia; and on this side the only harbours, unless we include Ancona, are Brindisi, Barletta, and Bari. Taranto is one of the best harbours in Italy. A vast fertile plain, but infested with malaria, adjoins the gulf of that name; while nearly everywhere in Calabria the coast, though richly clothed with southern vegetation, is more or less steep, and the only port is Reggio, on the Strait of Messina. To the north are the Gulfs of Policastro, Salerno, Naples, and Gaeta, that of Naples, sheltered by the islands of Ischia and Capri, being especially well provided with harbours. In Central Italy the west coast contains several long, shallow bays, divided by promontories which have been formed by alluvial deposits connecting rocky islands with the mainland; but still farther north, along the Riviera, the steep coast presents a number of admirable harbours, such as Spezia, Genoa, and Savona.

Climate and Vegetation. The generally warm climate of Italy is considerably modified in places by the presence of the mountain ranges or the proximity of the sea. The plain of the Po, open to the icy winds from the Alps, and closed to those from the south, has a cold if short winter (the mean winter temperature of Turin is nearly the same as that of Shetland), while along the Riviera the temperature is as high as, and sometimes higher

than, that of Rome or Naples. Throughout the peninsula the temperature is lowered by the presence of the Apennines, and some of the coldest districts of Italy are found in the Marches and in the Abruzzi uplands. Moreover, the Adriatic coast, exposed to the north-east winds, is colder than the corresponding west coast. July is in general the hottest month, but in the extreme south August; the coldest month in every province is January. The highest temperature recorded is 109° F. (in Apulia), the lowest -25° F. (on Monte Stelvio, in Lombardy); but over the whole country the extremes of mean annual temperature for the period 1876-88 were only 46 and 62° F. With regard to the rainfall a considerable difference is observable in the various sections of the country. In the very south there are but two seasons, a wet and a dry; whereas in Northern Italy there are two greater and two lesser rainy periods in the year, most rain falling in October and in spring, and least in winter. Over all the peninsula autumn is the wet season; but in the islands most rain falls in the winter months. The lowest mean annual rainfall is in Foggia (18 in.) and Sardinia (17); the highest in the Venetian province of Udine (60 in.), and in Bergamo and Novara. The distribution of moisture is very unequal, even in districts near one another (the yearly mean of Venice itself is less than half that of Udine); but in general most rain falls in the mountains. Snow is common in the basin of the Po, becoming less so as we proceed south, except in the uplands, where in some districts it lies for months. The cold mistral blows in the Gulf of Genoa, and the scorching sirocco affects the coast sometimes as far north as Venice. The singular clearness of the atmosphere, enhancing the charms of buildings and of landscape, strikes every visitor; but in many districts the evil presence of malaria, from July to October especially, forms a serious drawback to the sunny climate. Indeed, some of the most fertile tracts of Italy, as in Calabria, have for centuries lain deserted owing to this plague. Only six districts ('*circondarii*') are altogether free from malaria, and the malignant type infests the Adriatic lagoons, the Tuscan Maremma, the Roman Campagna, Apulia, most of the Calabrian coast, and Sicily and Sardinia. In 1887 no less than 21,033 deaths were set down to malarial fever. In the Campagna and elsewhere, however, drainage operations have had a good effect.

The vegetation of Northern Italy is in the main such as can endure the frosts of winter. But by the lake sides we find orange and olive trees, and the summer heat is sufficient to ripen rice and maize, of which, as well as other cereals and legumes, large crops are raised. Forests of chestnuts clothe the mountains, vineyards the lower hills, and the mulberry tree is extensively grown. The Riviera, so far as vegetation is concerned, belongs to Southern Italy, and the date-palms and orange-trees are continued at slight intervals along the Tuscan coast. In the interior of Central Italy, however, the vegetation still presents much the same features as in the Lombard plain, and it is only in Southern Italy that the Mediterranean flora prevails. Here, in the lowlands from Monte Gargano and Terracina south, the flora of central Europe gives place to palms and orange and lemon and citron trees, the cactus and agave, laurels, myrtles, olanders, and forests of arbutus and the evergreen oak. Only at elevations above 2600 feet do the chestnut and oak reappear, and higher still the beech; the birch and fir and pine are confined to the Alps.

Agriculture. Italy is pre-eminently an agricultural country. Of its entire area 87 per cent. is returned as productive, the unproductive tracts embracing only the higher mountain districts and

the marshes; and even these latter are being gradually drained. Nearly half of the productive area is under cultivation. The official returns of the area under cultivation in the two periods of five years, 1870-74 and 1879-83, show an increase in the number of acres devoted to vines, olives, oranges, maize, oats, barley, rye, leguminous plants, and potatoes, and a decrease in the case of wheat, rice, chestnuts, hemp, and flax. As regards their yield, however, all the grain crops exhibit a falling off; and the decrease became still greater in the years 1884-89. The following table shows the average number of acres under the several grain crops, and the produce, for the period 1879-83; also the produce for 1894, which was similar to that for 1893:

	1879-83.		1894.
	Acres.	Bushels.	Bushels.
Wheat.....	10,951,340	128,200,294	117,830,000
Maize.....	4,675,399	82,000,057	57,800,000
Oats.....	1,099,051	18,269,002	16,500,000
Barley.....	856,552	10,891,154	8,068,000
Rye.....	396,894	5,054,417	4,273,000
Rice.....	496,685	20,142,258	15,770,000

The five-year mean of the wheat crop, which is higher than the yield of 1888, is equal to 11.7 bushels per acre, or not much more than a third of the produce per acre in Scotland. The produce of maize per acre, again, is about seven-eighths that of the United States. These crops do not meet the needs of the kingdom, and wheat figures as the heaviest item in the annual imports. In 1888-89 the quantity of this cereal imported increased by nearly 30 per cent., while the import of maize leaped from 2168 to 158,356 tons. The reduced wheat acreage is mainly due to the great increase of vineyards, especially in Southern Italy, and of meadow lands; the reduction would be greater but that a good deal of reclaimed land has been given up to this crop and to maize. Barley is largely used for feeding cattle, especially in the islands. As a rule it has a thick husk, and is of little use for beer; but of late years the government has made experiments in several provinces, and also distributed parcels of seed, with a view to promote the cultivation of a grain better suited for brewing. Rice, which is grown in very few places outside the northern plains, has in many districts been given up, partly owing to the competition of foreign rice, but largely because constant crops of it exhausted the soil. Haricot beans are a common crop in all parts of the country, as well as lentils and a smaller proportion of peas; but the crop of common beans, lupines, vetches, and the like, for winter forage, is twice as large. Lupines are raised also for marmite. Potatoes are grown everywhere, although the quantity is decreasing; and tomatoes and vegetables are also of importance. Of hemp (principally in Emilia and Campania) some 70,000 tons are annually produced, and of flax (a poor quality) 15,000 tons. Tobacco is grown mostly in the provinces of Lecce, Benevento, Vicenza, and Belluno. The crop varies from 5,000,000 to 10,000,000 lb. a year. The grape harvest in Italy is second in value to the cereals alone, and exceeds that of any one of them. The area under vines has been increased by about half since 1870, especially in Piedmont, Southern Italy, and the islands; and the government has established several schools of viticulture, besides expending considerable sums in defending the vines from the attacks of the phylloxera. Vineyards occupy some 7,650,000 acres, and the production of wine in 1887 was nearly 728 million gallons, or more than that of France (cf. Vol. IV. p. 774)—although in 1889, a bad year, the crop yielded only 465 million gallons. The Italian wines are still comparatively poor; but a fair quality is pro-

duced in Sicily and some other places where good methods are employed, and a considerable quantity of this is exported. Below the 44th parallel the olive is among the most valuable products. In Northern Italy it is of no importance, except in Liguria; and even there it is much less widely grown than formerly. Indeed, over all the kingdom the amount of olive-oil produced has greatly diminished: in 1879-83 the average for each year was nearly 74 million gallons, in 1888 less than 30 million gallons. For oranges, lemons, bergamots, &c., the returns show nearly 3000 million fruit, about two-thirds coming from Sicily. Much of this is exported, but part is used in the manufacture of essential oils, lime-juice, &c. Among the less important fruits of Italy are the fig, peach, apricot, prickly pear, and many others. Over 11 million acres are under forest. The almond, walnut, and hazel, the sumach, cork, and dwari palm, and much more the mulberry, are all of value. Finally, the chestnut is not only a prominent tree in the upland districts, but yields an important article of food; yet the use of cereals is gradually becoming more general, and on the lower hills chestnut-groves are giving place to vineyards. Still in an average year the harvest is over 700 million pounds.

The extent of cultivable land in Italy is being increased, both by deforesting and by the reclamation of land from the rivers and swamps. Cultivation is still carried on in a very primitive fashion in some parts, but in others machinery has for long been not uncommon, and generally modern methods are gaining ground. In Northern Italy, Tuscany, and round Naples, indeed, the farming is of a very high character. Double crops in the same year, as of beans after wheat, are often the rule, and it is not unusual to see olive-orchards where vines are planted beneath the trees and crops of some kind fill the space between the rows. Irrigation is more extensively employed every year; but the expense attending its use has helped to keep much of the land in the hands of large owners. Nevertheless, the system of peasant proprietorship is extending. Otherwise, land may be held by the metayer system, or by rent, paid either in money or in kind; or the cultivator may be simply the paid servant of the landlord, receiving a share of the produce for his labour. In any case, the life of the Italian peasant is, as a rule, one of unremitting drudgery and poverty—often of privation, and agricultural strikes have occurred, as in 1889 in the Gallarate district of Milan, and in 1890 at Concesio, in Romagna.

The crop of hay and grass in 1888 was over 21 million tons. Since 1880 there has been an almost constant increase in the area devoted to meadows and pastures; and this has been encouraged by the minister of Agriculture, both by means of prizes and by the distribution of seed. In 1890 there were 5,000,000 cattle, 6,900,000 sheep, 1,800,000 goats, and 1,800,000 swine. There are no returns of the number of buffaloes, but they probably amount to from 10,000 to 15,000. Northern Italy is famous for its dairy districts, and large co-operative dairies have been established, especially in Lombardy, in Veneto, and in the valley of Aosta. The well-known Parmesan cheese is manufactured from Lombardy to Emilia, Gorgonzola also in Lombardy, and Gruyere in Piedmont. There is a government experimental dairy at Lodi, which publishes reports. Butter and meat are exported, and also live cattle; but the exports of these last have diminished, seemingly owing to errors in breeding and feeding. This matter has received the serious attention of the government, and a Commissione Zootecnica (1887) has been appointed, and technical schools established throughout the country. Also, there

are over 200 royal stations for stallions; and the government aid to horse-breeding in 1888 exceeded £65,000.

Fisheries.—There are valuable fisheries round the coast and in the lagoons. The tunny is the most valuable fish, and after that the anchovy and sardine; but the eel-fisheries of Comacchio (q.v.) are also of importance. The *grande pesca* (i.e. fisheries carried on outside the boats' own districts or on foreign coasts) employed 1323 smacks, with 8796 men, in 1886; and of these 195 boats and 1072 men were engaged in the coral-fishery, and 45 boats and 856 men in the sponge-fishery. In 1888 the boats numbered 1421, the coral and sponge fisheries employing respectively 163 and 48. The principal fishing-grounds are off the coasts of Sicily, of Tunis, and of Istria and Dalmatia. Sponges are fished off Tunis, and coral now almost exclusively off Sicily—and even the Sicilian banks are rapidly becoming exhausted. In 1880 the discovery of a new bank at Sciaacea raised the total quantity fished there to 9,906,000 lb.; in 1888 it had fallen to 1,290,000 lb. In 1894 the total value of fish caught was about £6,800,000, and of coral raised nearly £90,000. The coral is sent across to the mainland in the rough state, and is worked chiefly at Torre del Greco, Naples, Leghorn, and Genoa.

Minerals.—Italy contains no deposits of bituminous coal, nor, except in a few localities, of iron. A very little anthracite and about 300,000 tons of lignite are raised annually, most of the latter in Tuscany and Umbria; and peat is found in many districts. Nearly all the iron is raised in Elba (q.v.), and a very little in Lombardy and Piedmont. The great mineral product of Italy is sulphur, which represents nearly half of the annual value of all minerals raised throughout the Kingdom; and of this nearly nine-tenths is obtained in Sicily. The total value of the mineral products decreased in 1882-94 from £2,952,610 to £2,150,000. In 1888 the principal items were sulphur, £1,000,500; zinc ores, £286,500; lead ores, £276,500; lignite, &c., £107,000; iron ores, £80,000; silver ores, £77,000; mercury, £68,000; copper ores, £65,000; boracic acid, £52,000; and gold ores, £19,500. The number of persons employed in this industry was 47,063 in 1887, 49,154 in 1888. In addition must be mentioned the quarrying of marble, granite, and alabaster, valued at nearly a million sterling annually, and employing some 20,000 men. The marble of Carrara (q.v.) is especially famous, as is also the alabaster of Volterra, near Pisa. See ALABASTER.

Manufactures.—Partly because of the high cost of fuel, Italy does not rank among the great manufacturing countries of Europe; but in some branches of trade her productions are of considerable importance. Owing to various causes, complete statistics are not in every case obtainable; but the great advance of the manufacturing industry generally may be estimated from the increase in the annual imports of coal, which increased nearly fivefold between 1871 and 1889. Still the steam-power machinery of the country, according to its relative horse-power, is equal to only about one-fortieth that of Great Britain, and is less than a third of that moved by water. Of principal importance is the silk industry, which employs some 150,000 persons, exclusive of those engaged in rearing the silk-worm; in 1889 this culture was carried on in 5188 communes, and by over 570,000 persons; the cocoon harvest amounted to 75,689,655 lb. (in 1888, to 96,798,272 lb.). The great seat of the silk industry is in Northern Italy, and especially in the province of Como. A large quantity of raw silk is still exported, to be returned in the form of textile goods. Nevertheless, the exports of silk in all forms greatly exceed the imports—in 1888 by

£9,400,000. The manufacture of thread and of cotton tissues shows a steady advance, as does also the spinning and weaving of wool. The manufacture of jute is confined to a few large factories. The north is the seat of the iron industry, but there is a large manufactory of iron rails at Terni, in Perugia; the principal copper-works are at Leghorn. The machinery manufactured, including that turned out by the government establishments, is valued at little short of £4,000,000 a year, the chief centres of this work being Turin and Milan; but machinery to the value of between one and two millions sterling is still imported annually. The manufactures of glass and ceramic wares are valued at £2,500,000; the former include the famous Venetian glass, and the latter majolica, faience (so called from Faenza), and other valuable wares. With these may be classed the cutting of carnos and the production of mosaics at Rome, Naples, and Florence, and also the working of coral. For the preparation of food-stuffs there are, according to the most recent returns available, 30,414 mills moved by water, steam, or wind (29,418 by water); besides these there are no less than 26,994 moved by animal power. The latter are chiefly for domestic purposes, however, and most of them are in Sardinia. About 6 million tons of corn and maize are ground annually, and nearly 90,000 persons are employed more or less regularly in the mills. Large quantities of flour-pastes are manufactured, principally from foreign wheat, which is harder than the native grain. Of spirits, made mostly from maize, the production in the fiscal year 1886-87 was 5,324,412 gallons; and to this must be added marsala, vermouth, and other liqueurs. In the same year there were 139 breweries in operation. Small quantities of sugar, glucose, and chicory also are produced; confectionery and preserved fruits are regular articles of export. The manufacture of tobacco is a government monopoly; in 1887 there were 17 factories, and two depôts (at Leghorn and Sampierdarena), employing 16,387 hands; the production amounted to nearly 40,000,000 lb. The output of the tanneries is estimated at £4,000,000, and there is a considerable export of gloves. There are numerous paper-mills in Piedmont, Lombardy, and Campania, and factories of straw-hats, the principal at Florence, and of cloth, silk, and felt hats in Piedmont especially. The export of straw-hats, though still considerable, is diminishing, while that of straw-plaiting is increasing. Sulphuric and tartaric acid, sulphate of quinine (made at Milan and Genoa), salt, soap, oils, candles, wax matches, &c. are also exported. Finally, the extensive building operations carried out within recent years with a view to modernise the large cities have given a great impulse to the manufacture of bricks and the like, as well as to the quarrying of stone.

Commerce.—The foreign trade of Italy is facilitated both by the extensive seaboard and good harbours and by railway connections with the countries beyond the Alps. In 1878 the kingdom was eighth in the list of European commercial nations, being surpassed by Great Britain, Germany, France, Holland, Belgium, Russia, and Austria; ten years later it had outdistanced Austria, and was about equal with Russia. The imports during these ten years showed a nearly steady increase, amounting finally to over 50 per cent.; the exports did not vary greatly, but on the whole exhibited a very slight falling off. The value of the former (excluding bullion and goods in transit) in 1887 was £61,030,000; of the latter, £39,955,000. In 1888 the imports fell to £46,584,000, the exports to £35,677,000; in 1889 the returns rose again to £55,627,000 and £38,019,000 respectively. Taking the entire trade of the country, one-fourth is set down to articles

of food, about a half to raw and partially-prepared materials, and the remainder to manufactured goods. Wheat represents an eighth of the total imports, and yarns and tissues nearly as much; after these come raw cotton, coal, timber, sugar, machinery, fish, iron, coffee, hides, cheese, tobacco, in this order. Silk, mostly raw or thrown, supplies about three-tenths of the exports, and wine more than one-tenth; olive-oil, fruit, eggs, hemp and flax, sulphur, worked coral, marble, and rice come next. The commercial intercourse of Italy up to the end of 1887 was chiefly with France (over 34 per cent. of the total); Great Britain (nearly 15 per cent.), Austria, Germany, Switzerland, and Russia following at some distance. In 1888, however, Italy entered on a war of tariffs with France, which had the immediate result of reducing the direct trade with the latter country by almost one-half, and Britain advanced to the first place. This change is in a large degree only apparent, for great quantities of Italian products, notably raw silk, have since been exported to Switzerland first, and thence to France. Nevertheless, its effect is to render the figures for the years that follow 1887 misleading. The principal imports from Britain are coal, iron, cottons and woollens, machinery, and sugar; the chief exports thither are olive-oil, oranges and lemons, with their essences and syrups, hemp, sulphur, chemicals, and marble. The Italian mercantile marine at the end of 1888 embraced 6810 sailing-vessels and steamers, with a tonnage of 853,033 tons; the steamers numbered 266, of 175,100 tons. Over nine-tenths of the whole were employed in the fishing and coasting trade. In the same year 111,257 vessels of 20,048,258 tons entered (111,103 cleared) Italian ports. The Italian shipping engaged in international navigation has rapidly fallen off of late years. More than half the steamers entering Italian ports are British, and these carry nearly four-fifths of the maritime trade. The most important seaports are Genoa and Savona, Leghorn, Naples, Venice, Messina, and Palermo. In 1894, of a total import of £43,000,000 (excluding specie) only £5,555,000 were from Britain; of an export of £10,000,000 £3,130,000 were sent to Britain. In 1894, 113,983 vessels of 28,200,000 tons cleared from Italian ports.

In 1895 there were 9300 miles of railway. Since 1885 the state lines have been worked by private companies, and about four-fifths of all the railways belong to two great systems, the Mediterranean and the Adriatic. Two notable tunnels, the Mont Cenis and St Gothard, connect the Italian system with those of France and Switzerland, and a Simplon tunnel is projected; there is also a coast line from Genoa to Nice, and several connections with the Austrian railways. There were also 1405 miles of steam tramways. In 1886 there were 50,101 miles of roads open, besides 7663 miles in construction; and the total length of navigable canals, mostly in Lombardy and Venice, was 655 miles. The rivers are navigable for about 790 miles. In 1881 there were 3420 post offices in Italy, in 1889 there were 4558; the surplus of revenue over expenses in the latter year was about £200,000. In 1889 there were 21,955 miles of telegraph lines, and telephones were to be found in sixty communes.

Social Conditions. The principal occupation, agriculture, employs nearly a third of the entire population, and the manufactures only about half as many. Nevertheless, the proportion of inhabitants congregated in cities is unusually large, and in Southern Italy and the islands even the peasants prefer to have their homes in some town or village. The sanitary condition of these towns, in which nearly three-fourths of the entire population is congregated, is often deplorable. A commission appointed in 1885 reported that in 6404 communes

there were no sewers of any sort, in 1313 there were sewers capable of carrying off rain-water alone, and in only 17,541 communes such as would carry off foul sewage; that in 3636 communes, with a total population of nearly 11,000,000, most of the houses had no privies, and in 1286 other communes, with a population of 2,762,000, this adjunct was lacking in almost every house; and that 1881 communes, with 9,500,000 inhabitants, were supplied with drinking-water of poor or bad quality, and 1495 others, with 6,000,000 inhabitants, did not receive water sufficient for the actual needs of the people. In such circumstances the prevalence of infectious diseases is not to be wondered at: in 1887 the proportion per million inhabitants of deaths from all causes in England and Wales was about two-thirds that of Italy, but from infectious and contagious diseases less than one-third. Yet in some respects an improvement is visible in the hygienic condition of Italy. The annual death-rate from malaria appears to be steadily diminishing, as does that from *pellagra*, a wretched disease resulting from insufficient and unwholesome food, and often ending in insanity; it is confined to the northern and central provinces. The proportion of deaths from alcoholism in the larger towns is much the same as that for all England, but for the whole of Italy it is only a third as great. The food of the artisan classes consists mainly of cereals and beans; maize is mostly used in the north, where also the small proportion of animal food is about double that consumed in the south. The diet of the peasantry, again, almost never includes meat or fish, and seldom any wine. Signor Bodio has calculated that the average daily wage overhead of work-people in factories, mines, &c. is about two lire (1s. 9d.); that of agricultural labourers, allowing for periods when their work is not required, he calculates at not much over one lira for every day in the year. The character of the people is in general sober and thrifty, and they prove excellent workmen where sheer labour is required, as in quarries and drainage operations; skill in the use of steam machinery, and the like, may be expected to develop with experience. Moreover, the old Roman spirit of stern utilitarianism is stronger in the sons of modern Italy than the æsthetic artistic temperament principally associated with them in many minds: the national type must rather be described as thoroughly practical; the 'improvements' that are transforming Rome, Florence, Naples, the miles of new streets, the staring blocks of modern houses, Paris-like, that have displaced the picturesque squalor of a generation ago, are sufficient evidence of this. Numbers of Italians migrate every year in search of work, and many who go abroad for longer periods still hope to return to their own land with a competence some day: in this respect the Italian love of country appears only less strong than the Chinese. The national character is passionate and quick to resent an injury, and the annual number of homicides per 100,000 of the population is nearly twenty times as great as in England; no other country of Europe, except Spain, approaches Italy in this respect. Capital punishment was definitely abolished in 1889. Assaults and wounding are also very numerous, and as regards all these offences against the person the southern provinces and the islands enjoy a grim pre-eminence. Yet a slight general decrease in the number of crimes and offences is observable within recent years. With regard to illegitimacy, Italy's position may be seen in the separate article on that subject; but here it should be noted that the percentage of illegitimate births has increased by more than half since 1863. The *ruota*, or foundling-wheel, is gradually being sup-

pressed: in 1866 it was in use in 1179 communes, in 1888 in 594 only, and these mostly in Sicily and the southern provinces.

Religion and Education.—Religious freedom is now secured to all creeds, but the Roman Catholic is the recognised state religion, and claims all but a very small fraction of the people. Of Protestants there are about 62,000, and of Jews 38,000; the former include some 22,000 Waldensians (q.v.). There are in Italy 51 Catholic archbishops and 223 bishops, and over 76,500 parish priests. The rank and dignity of the pope, as a sovereign prince, is recognised by the law of 1871 which defines the relations of the church and state; his person is sacred, his residence inviolable, and he has his own court in the Vatican (see ROMAN CATHOLIC CHURCH). Under a series of laws the great majority of the religious houses have been suppressed, small pensions being paid to most of their inmates who had taken vows, and their property confiscated. Part of the funds thus placed at the disposal of government have been devoted to educational purposes.

Education is under a minister of public instruction, who is assisted by a council; and in every province there is a school board, under the direction of the prefect. Nearly $1\frac{1}{2}$ million sterling, or about half the sum appropriated for this purpose in England and Wales, is set aside by the state annually for education; to this the communes and provinces add $2\frac{1}{2}$ millions. At the formation of the kingdom of Italy the general ignorance was incredibly profound, although learned societies existed in every large town, many of them, like the universities, of European fame (see ACADEMY). Reference to the separate article on illiteracy will show that, as regards education, Italy still comes behind most of the nations of Europe; yet notable progress has been made. In 1861, of those over nineteen years of age, 65 per cent. of the males and 81 per cent. of the females were unable to read or write; in 1881 the percentage had fallen to 54 for the males and 73 for the females. In 1866, of the men married 60 per cent. and of the women 79 per cent. had to make their mark; in 1888 the percentages were 42 and 62 respectively. The various parts of the kingdom differ widely in this respect. Piedmont has only 15 per cent. of conscripts and 11 per cent. of the men married illiterate, while in Calabria the respective percentages are 73 and 64, and in Basilicata 73 and 70. In all cases the proportion of women illiterate is greater than that of men. The notion of intellectual equality between the sexes is confined to a few earnest reformers, and there is much less adequate provision for the higher education of girls, although the universities nominally are open to women as well as men. The convent schools teach mainly embroidery and devotions, and the government and superior schools are not satisfactory. In 1861, however, a good high school for girls was opened at Milan, and its success has led to the establishment of many similar schools in other towns. Primary education is compulsory, and separate boys' and girls' schools are to be found in all but the very poorest communes. In 1861 '86 the number of pupils (male and female) in these elementary schools increased from 885,152 to 2,252,898; in 1886 there were 46,673 such schools open, besides 7553 private elementary schools. There were also 2139 asylums for children, many of them conducted on the kindergarten system, with 252,763 children; and there were 7444 night-schools with 283,230, and 5886 Sunday-schools with 169,609 pupils enrolled, besides 133 normal schools with 40,542 pupils. In 1888 the gymnasiums numbered 728 (255 episcopal and 441 private), with 49,980 scholars; the lycæums, 321 (124 episcopal and 55 private), with 13,688 pupils. Also, there were 481

technical schools and institutes (84 private), with 34,602 students; 23 mercantile marine schools (19 governmental), with 756 pupils; and 22 collegiate institutions and superior special schools, with 2662 students and 170 'hearers.' Finally, there are in Italy 21 universities, 17 of them governmental and 4 'free'—i.e. maintained by the provinces and communes; the total number of students and 'hearers' was 19,441 in 1893-94, besides 100 who were entered at three lycæums that provide a university course. The oldest university is that of Bologna (q.v.), the largest that of Naples (4104 students). The great body of Italian students are enrolled in the faculties of medicine and jurisprudence; theology is not taught in any of the universities. The students of divinity in the seminaries in 1881 numbered 11,277.

Government.—Italy is a constitutional monarchy, the executive power vested in the king, with succession in the male line, being exercised through responsible ministers. The legislative functions are in the hands of the king and parliament conjointly, the latter consisting of a senate and chamber of deputies. The number of deputies is 508; the franchise is extended to all citizens who are of age, can read and write, and pay 20 lire of direct taxes. The senate is composed entirely of life-members, with no fixed limit as to numbers (at present about 300); all its members, except the princes of the royal family, are nominated by the king, and must be forty years of age or upwards. Neither senators nor deputies are paid, but they have the right to travel free by rail or steamer in any part of Italy. Money bills must originate in the Lower House. The parliaments are quinquennial, but may be dissolved by the sovereign at any time. Ministers, who number eleven, are not necessarily members of either house. The government of the provinces, with a prefect at the head of each, is very much the same as in France.

Army and Navy.—Military (for the maritime population, naval) service is compulsory for all citizens from the age of twenty to thirty-nine, but only about 80,000 annually are drafted into the standing army (3000 into the navy). Recruits are divided into three classes, those of the third entering the territorial militia at once, and receiving unlimited leave, except, in time of peace, for 30 days' drill every four years. Recruits of the second category are enrolled for eight years in the permanent army (with unlimited leave) and four in the mobile militia (landwehr), and then enter the territorial militia. The infantry of the first category have, before being transferred to the territorial militia, three years with the colours, eight on leave, and four in the mobile militia; the other arms, nine years with the colours and on leave. One-year volunteers are admitted. The standing army in 1895 numbered 253,000 men, and those of the permanent army on unlimited leave 590,000; the total war strength, including mobile and territorial militia, was returned at about 2½ million men, about one million of whom had received a regular training. The carabinieri (21,000) perform the duties of gendarmes. There are a staff-college and a school for artillery and engineer officers at Turin, others for infantry and cavalry officers at Modena and Parma, for cavalry officers at Pinerolo, and for the sanitary corps at Florence, and military colleges at Milan, Florence, Rome, Naples, and Messina. A chain of fortresses has been erected along the northern frontier; there are numerous forts and batteries in the basin of the Po and along the coast; and Rome is protected by a circle of fifteen forts.

After the disastrous defeat at Lissa in 1866 the navy was reconstructed, and now, after years of unremitting exertion, Italy is one of the strongest

maritime powers of Europe. In 1876 the navy included 14 armoured, 7 unarmoured, and 2 despatch vessels, besides other vessels that brought the effective total to 53, with an armament of 298 guns; the thickest armour was 8½ inches. According to a report published in 1890, Italy had then 18 armoured battle-ships, 19 protected cruisers, 9 despatch-vessels, 6 torpedo cruisers, 1 sea-going torpedo boat, and 8 gun-vessels; the maximum thickness of armour carried by these vessels was 21½ inches, and their approximate value was put at 8½ millions sterling. There were also 128 torpedo boats, and other vessels that brought the total to 234 ships, representing with their armament a value of £15,000,000. Two of the armour-clads, the *Italia* and *Lepanto*, are the largest war-ships yet built, and the armament of the navy includes several guns of 100 and 106 tons. The period of service in the navy is eighteen years, but a limited number only of the conscripts actually serve four years, and the rest are normally on permanent leave. In 1888 there were about 17,500 officers and men on active service.

Finances.—The finances of Italy present an interesting study. From the first the young kingdom was burdened with the cost of the war with Austria and the debts of the old Italian states, and moreover has been obliged to face many years of extraordinary expenses; whilst the land, especially in the south, has never been developed to anything like its full capacity, and the revenue has been restricted in consequence. In 1862 there was a deficit of nearly £18,000,000, and it was not until 1875 that the first small surplus was obtained. Except the first half of 1884, the next ten years showed a surplus, larger or smaller; but each of the four years following 1885 ended in a deficit. Both income and expenditure have steadily increased: in 1862 the former was over £19,200,000, the latter £37,000,000; in the financial year 1888-89 the actual revenue was £60,034,000, the expenditure £69,409,000—deficit, £9,375,000. The chief sources of income are the customs, the income, land, and house taxes, and the tobacco monopoly; the principal expenses are the interest of the public debt, exceeding 21 millions sterling, and the cost of the army and navy, which is nearly as great. In proportion to the productivity of the country, Italy's public debt is very heavy. At the end of 1861 it was slightly over £125,000,000; but a long succession of annual deficits, extensive railway and other public works, and costly armaments have raised it year by year till in 1895 (when the revenue and expenditure were about £70,000,000) the debt had reached £492,344,300, amounting to £15, 18s. 5d. per head of the population, exclusive of the communal and provincial debts. Meanwhile it should be noted that the Italian government has removed certain of the old, objectionable imposts, such as the grist tax; and in 1883 the forced paper currency was withdrawn from circulation.

For information as to Italy the best sources are the admirable official publications, a complete list of which is included in the *Saggio di Bibliografia statistica Italiana* (3d ed. Rome, 1890). The *Annuario statistico Italiano* (published since 1878) contains topographical as well as statistical information; most of the statistical portion will be found summarised in the *Statistica's Year-book*. A comprehensive review of Italy's progress is presented in a memoir, equally able and candid, *Di alcuni Indici del Progresso economico e sociale d'Italia* (Rome, 1890), by Signor L. Iodio, one of the most masterly of present-day statisticians. The *Dizionario geografico* (8 vols.), by Amati, is part of a monumental work in course of publication at Milan (*L'Italia sotto l'Aspetto fisico, storico, artistico, e statistico*). See also Laveleye, *L'Italia attuale* (Paris, 1881), and, among English works, Gallenga's two books on Piedmont, his *Italy Revisited* (2 vols. 1875),

and *Italy Present and Future* (2 vols. 1887); the books of A. J. C. Hare (q.v.); and Beauclerk's *Rural Italy* (1888). For Southern Italy, see Lenormant, *La Grande Grèce* (3 vols. 1881-84) and *A travers l'Apulie et la Lucanie* (2 vols. 1883); and Mrs Ross, *The Land of Manfred* (1889).

HISTORY.—The ancient history of Italy will be more conveniently treated of under **ROME**; see also **ETRURIA**, **UMBRIA**, &c. In 476 A.D. the Herulian mercenaries in the pay of the western empire rose in revolt, and proclaimed their leader Odoacer king; and the last emperor of the West, the pretty boy Romulus Augustulus, was sent to end his days amid the woods and fish-ponds of Lucullus' villa near Naples. The senate, by Odoacer's command, recognised Zeno as head of the western as well as the eastern empire, and he in turn bestowed on the Teuton leader the dignity of 'patrician.' For thirteen years Odoacer's rule was undisputed; but in 489 Theodoric, king of the Ostrogoths, invaded Italy with a commission from the Greek emperor, besieged the Herulian in Ravenna, and in 493, after his surrender, slew him with his own hand. In spite of this bloody beginning, Theodoric's rule, which lasted till 525, was wise and, on the whole, just. But the Arian faith of the conquerors held them and the Italians apart, and when Justinian's general Belisarius was sent to reconquer Italy he was welcomed by the colonists of Sicily and the south. From 536 to 553 the war was desperately maintained, the hero on the Gothic side being Totila (541-552). But the valour of the barbarians was outmatched by the generalship of the aged eunuch Narses; and in 553 Teias, the last king of the Goths, was slain in battle, and the descendants of the host who had followed the Amal king into Italy sixty-four years before, now few in number and sore at heart, were permitted to march back across the Alps. Italy was now governed from Ravenna for a few years by an exarch or viceroy; but in 568 came an invasion by the Lombard nation, under their king, Alboin, and all the central portion of the peninsula passed from under the sway of Byzantium. Pavia was made the capital of the new kingdom, and the great duchies of Spoleto and Benevento were founded, pressing on Rome and the Greek maritime cities of the south. Yet the Lombards were not strong enough to occupy the whole peninsula, and Rome and most of the coast towns, as well as the islands, remained to the emperor. The invaders imposed on the country a sort of feudal system, and, being Arians, treated the Italians with great harshness, until Gregory the Great effected their conversion to orthodoxy. From this period the popes for a time appear as the champions of the national cause. Leo the Isaurian's decree against the worship of images was met by Gregory II's declaration of Roman independence; and in 726-56 the popes succeeded in driving out the exarch and checking, with the help of the Franks, the encroachments of the Lombards. Pepin twice crossed the Alps, compelled the Lombard king to yield up the exarchate and the Pentapolis, which he had conquered, and presented them to the pope in 756; this gift was the nucleus of the temporal sovereignty of the bishops of Rome.

In 774 Pepin's son, Charlemagne, who had been summoned to the aid of the pope, deposed Desiderius, the last Lombard king, and added his dominions to his own; in 800 he was crowned emperor of the Romans. Meanwhile the Lombard duchies in the south were still independent, and Sicily and a number of free cities in Southern Italy, as well as Venice, recognised the Greek overlordship. But in the 9th century the Saracens subdued Sicily, landed on the mainland, and even threatened Rome. Leo IV. fortified the suburb on the

north bank of the Tiber, which after him was called the Leonine city, and called to his aid Louis II., Charlemagne's great-grandson, who, with the help of the eastern emperor, checked the progress of the Saracens for a time. But after the death of Louis the infidels compelled the helpless pope to pay tribute; and the Greeks, profiting by the weakness of Charlemagne's successors, recovered most of Southern Italy, and held it, under an officer entitled Catapan, till 1043. Eight kings of the Carolingian line were acknowledged in Northern Italy, their rule ending with Charles the Fat in 887. Then, till 961, succeeded ten so-called Italian sovereigns—dukes of Spoleto and Friuli, the German Arnulf, Hugh of Provence, Berengar, marquis of Ivrea, and others. Under their feeble sway the power of the feudal nobles, and, within the cities, of the bishops, waxed great, the papal chair was occupied by men of infamous life, and Magyars, Saracens, and Northmen overran the country, turning wide tracts into a desolate wilderness. In 951 Berengar II. was compelled to do homage to the German king, Otto of Saxony. He was suffered to rule until 961, and then deposed; and in 962 Otto was crowned as king of Italy at Milan and as emperor at Rome. From this time the right to the crown of the Roman empire (two centuries later it was the Holy Roman empire) was held to accompany the German kingship. Except in name, there was no longer an Italian kingdom, and, with its foreign emperors occupied for the most part beyond the Alps, the country was in some degree left masterless. Its division into separate states was now but a question of time.

Moved by the scandals of the papacy and the constant revolts in the city, Otto took the election of the popes away from the Romans, chose a pope of his own, and put the city in his charge. Elsewhere he encouraged the rise of the communes as a check upon the great vassals. The towns had already been permitted to raise walls as a defence against the barbarians, and now the chief cities were freed from the jurisdiction of the counts. The death of Otto III. in 1002 was followed by a dispute for the crown; Rome, the papacy and the city, fell again into the hands of the Tuscan counts, while the Lombard cities gained in importance as their alliance was sought by one side or the other. Milan supported Henry of Bavaria, who had been elected in Germany; and he severely punished her rival Pavia, who had espoused the cause of the Lombard Ardoin. Henry died in 1024, and was succeeded by Conrad of Franconia, who was invited into Italy and crowned with the iron crown at Milan, by Heribert, the archbishop. Under this prelate Milan advanced greatly in power and independence. An effective militia was formed, and Heribert is said to have invented the *carroccio*, a car which carried into battle the city's banner and an altar, and round which the burghers fought as in defence of a sacred thing. The citizens had already formed themselves into a *parlamento*, and, while Heribert lived, the power of the smaller counts who had now come to dwell in the city was brilled. The other Lombard cities also were rising into some degree of independence. Pisa and Genoa, besides Venice (which acknowledged the nominal sovereignty of the Greek emperor), were becoming great by their command of fleets; and they succeeded to the rich carrying trade of the Mediterranean after the fall of the Greek cities in the south before the Normans. During the first half of the 11th century a body of Norman adventurers had gained a firm footing in Apulia, which they ultimately conquered as a county for themselves. The pope, Leo IX., marched against them, and was defeated and taken prisoner by Robert Wiscard or Guiscard at Civitella (1053);

and Wiskard obtained from him the investiture of his present and future conquests, which he was to hold as a fief of the holy see. Robert extended his power on the mainland, and took the title of Duke of Apulia and Calabria in 1059. In 1060-90 his brother Roger conquered Sicily from the Saracens; in 1127 the family's dominions in Apulia, Calabria, and Sicily were united by his son Roger, who in 1130 assumed the title of king of Sicily.

Meanwhile the fierce struggle over Investitures (q.v.) had been fought out between emperor and pope. When the archdeacon Hildebrand became Pope Gregory VII. he enforced the celibacy of the clergy, as Leo IX. had already endeavoured to do; and in 1075 he condemned the investiture of ecclesiasties by lay lords. Otto the Great and Henry III. had appointed and deposed popes, and therefore this latter decree led to a quarrel with Henry IV. (q.v.). At a diet in 1076 Gregory was deposed. The pope replied by excommunicating the king, who was compelled by a rebellion in Saxony to submit and do penance at Canossa, the castle of the Countess Matilda of Tuscany, the pope's ally. Henry, however, soon renewed the strife, appointed an antipope, and in 1084 took Rome, was crowned, and besieged Gregory in the fortress of St Angelo. Thence the pontiff was delivered by Wiskard, who drove the emperor off, and carried Gregory away from his riotous subjects to end his days at Salerno. The struggle, however, was carried on by Gregory's successors, till by the concordat of Worms (1122) the emperor yielded the main principle at issue, surrendering to the cardinals the election of the pope, who was still to possess the right of conferring the imperial crown. By the death of the Countess Matilda, too, in 1155, the church had inherited her vast domains; and, although the emperor took possession of them, the popes retained their claim, to be revived in after years.

From this long struggle the northern cities emerged strengthened and practically autonomous. They still belonged to the empire; but they were governed by their own magistrates, called consuls, aided by an oligarchical council; and they enjoyed, and unhappily took frequent advantage of, the right to make war on their own account. The quarrel of the Guelphs and Ghibellines (q.v.) arose in Germany at this time, and before long these names were heard everywhere in Italy; but here they stood not alone for the pope's party and the emperor's, but also for the burning jealousy and hatred of rival cities, each struggling to rise at the cost of its neighbours. Arnold of Brescia (q.v.) for a time established a republic in Rome, but it was suppressed by Frederick Barbarossa in 1154. In that year Frederick, who had been elected king in 1152, came into Italy to take away the self-government of the towns, and reduce them to their former subjection to the emperor. After punishing several hostile cities, he went on to Rome and was crowned by Adrian IV. (Nicholas Breakspear), the only pope of English birth; but he soon quarrelled with him, and on Adrian's death supported an antipope. In 1158 Frederick returned from Germany, and compelled Milan to surrender, after a month's siege. He now set in every town a podestà to administer justice, who should be chosen always from another city; and from cities and barons alike he took away the privilege of making war on one another without his permission. An attempt to appoint their consuls also drove the Milanese into a second revolt, in 1159; but Frederick was delayed by the heroic defence of Crema, and it was not till May 1161 that he again invested Milan. The city held out till March 1162, and was then destroyed by the vindictive imperialists, and the people driven from the ruins.

Soon afterwards the cities of the Veronese march formed a league of defence against Frederick which he was unable to crush. In 1167 he besieged the pope, Alexander III., in the Coliseum; but the latter escaped to Benevento, while a terrible pestilence fell upon the German camp, and Frederick with difficulty led the remnant of his army north to Pavia. Only this city and the Marquis of Montferrat in all North Italy had held back from the great Lombard league, which had meanwhile been formed and had restored the Milanese to their city. In 1168 Frederick fled in disguise across the Alps; and in the same year the confederates founded a new city on the plain between Pavia and Montferrat, to be a check on these two. The league named it Alessandria, in honour of their ally the pope: *della paglia* ('of straw'), their enemies added in derision; but its ditch and rampart of earth held Frederick at bay all through the winter of 1174-75, till he was forced to raise the siege. Finally, the crushing defeat at Legnano (May 29, 1176), from which field he hardly escaped with his life, made him willing to treat for peace. In 1177, at Venice, the emperor came to terms with the pope, and agreed to a six years' truce with the Lombard towns; in 1183 a permanent peace was ratified, the cities retaining their right of war and of self-government, and the emperor his podestàs and his rights of sustenance and support against enemies outside the league. The rule of podestàs was soon adopted outside of Lombardy as well, for the settlement of nobles in the towns had introduced a lawless element and given rise to factions; so that a supreme judge who was not a townsman, who held office for a single year, and had then to render an account of his administration, was most likely to prove impartial. Yet from the podestàs to the despots was but a step, and this was taken a few years later.

Since the battle of Civitella the Normans had continued faithful allies of the popes, and it was with the object of depriving the latter of this powerful support that Frederick now had his son Henry VI. married to the heiress of Sicily. Frederick died in 1190, and in 1194 Henry was recognised as king, and the Norman rule in Southern Italy came to an end. He died in 1197, and the next year his wife, who had acknowledged the pope as overlord, died also, leaving their infant son Frederick to the guardianship of Innocent III. The papal territory had now become extensive, and the establishment of a Latin empire at Constantinople (1204), during the fourth crusade, added to the prestige of the Roman see. But the chief gainer by the capture of the eastern capital was Venice, who, as a reward for lending her fleet, was presented by the victorious crusaders with a large share of the divided empire, and was able to occupy at least a number of islands and coast territory; she was now supreme in the Levant. Frederick II., who was crowned emperor in 1220, was king of Italy, Sicily, Sardinia, Germany, Burgundy, and Jerusalem. So formidable a prince made popes and communes both uneasy. He was excommunicated by Gregory IX. in 1227, because he delayed his departure on a promised crusade; and afterwards, when he had gone to the East, while he was crowning himself at Jerusalem his enemies were still busy at home. The pope, whose hands were greatly strengthened by the newly founded Franciscan and Dominican orders, stirred up the Lombard cities to revolt, and, after Frederick had crushed the Milanese at Cortenuova (1237), drew Venice and Genoa into the league against him. Frederick's cause was upheld in Northern Italy by Ezzolino da Romano, infamous for his cruelties. In 1245 Innocent IV., the emperor's personal

enemy, had him declared dethroned by a council convened at Lyons; and after five years of harassing anxiety, his life the object of constant plots, Frederick died in December 1250. The cause of his son and grandson was upheld by his natural son Manfred, who in 1258 became king of Sicily. There was no abatement of fury in the fierce struggle between Guelphs and Ghibellines, but the balance of success so far inclined towards Manfred after the battle of Montepertoso (1260), which restored Florence to the Ghibellines, that Urban IV. invited Charles of Anjou into Italy to head the Guelphic party. In 1266 Manfred was defeated and slain, and the Swabian line came to an end with his nephew Conradin, who was beheaded at Naples. The Guelphs were again supreme; but Gregory X. restored their banished rivals to their cities, and for a time made the two parties live in peace. Charles, who received the kingdom of Sicily as the gift of the popes, had promised that it should never be held along with the empire; and now, as a final check to the Angevin's possible ambition, the pope brought the dispute to a close which had kept the empire without a head, and crowned Rudolf of Hapsburg, who was elected in 1273. This emperor in 1278 recognised the popes as temporal sovereigns, and their power was henceforth firmly established over Rome and the Campagna, Emilia, the Romagna, and the March of Ancona; and, as Rudolf left Italy to itself, the Guelphic party was enabled to strengthen its power and to crush such hostile cities as Pisa. Charles lost Sicily by the rebellion which began in the Sicilian Vespers (q.v.), in 1282; and the island gave itself to the House of Aragon, which, as the popes were hostile, necessarily became Ghibelline. Meanwhile, in Tuscany the triumphant Guelphs had become broken up into factions, the Neri and Bianchi (Blacks and Whites), the former violent Guelphs, and the latter at first moderate Guelphs, until the fierce animosity of their opponents made them Ghibellines. For in 1301 Charles of Valois, who had been called in by Boniface VIII. to help the Neri, entered Florence, and gave the Bianchi up to the cruel vengeance of their enemies; among those banished from the city was the poet Dante. Under Clement V. the seat of the papacy was removed, in 1309, to Avignon, where it remained for the next seventy years. In the following year the new emperor, Henry VII., came into Italy to revive the Ghibelline party, and to restore peace and order. The task, however, was now beyond the power of any German master. Henry died in August 1313, having effected no lasting change except in Milan, which he had handed over to the Ghibelline Visconti.

We have now reached a period when the cities of Northern Italy had fallen under the sway of tyrants or despots. The feudal power of the rural counts had gradually been lessened by the communes, until the nobles had become citizens. But they merely exchanged their castles for fortified palaces in the cities; and, although the podesta had curbed their power for a time, his office eventually became not so much that of a dictator as of a judge, and the interminable wars had tended to give the nobles an undue predominance, since, being trained to arms, their military skill naturally placed them above the burghers. In some towns, such as Florence, where the democratic spirit was strongest, they were kept in check by a *gonfaloniere of justice*; but in most cities the *captain of the people*, who represented the party in the ascendant, and in these war-times was of course a noble, gradually raised himself to the position of master. It was then his aim to depress the others of his own order, both to win popularity with the people and to prevent possible rivalry. At the root

of the wars fought between those in Italy who called themselves Guelphs and Ghibellines was the question whether the democracy or the aristocracy was to be supreme in the cities. Florence as yet preserved her republican independence; but, besides a hereditary oligarchy in Venice, despots were now established in all the great northern cities, each of which was glad to submit to a master who would put an end to the strife that had hampered its commercial prosperity. Titles were bought from the German emperors or assumed, courts were formed, and armies were hired; for wars were now waged in another fashion than that which had prevailed in Barbarossa's time. Then it was an honoured custom for the artisans and traders of a city to devote a week or a month in the year to harrying the fields of a rival commune, to draw its defenders into an ambushade, or even to capture and ruin the town, provided it did not hold out too long; in any case, the citizen-soldiers returned home in a few days, and took up their ordinary work again. Now, however, war was a science and soldiering a trade; the iron panoply and ponderous lance of the man-at-arms were not for the craftsman or the clerk. Therefore, in the 14th century, bands of mercenaries, or companies of adventure, under condottieri, made their appearance, selling their services to the highest bidder, or plundering the lands of the weaker states. Their battles were almost bloodless, the campaigns indecisive. Bound by a common profession, they were chiefly formidable to the taxpayer; and, for that matter, in their commercial prosperity the cities were at this time receiving the reward for which they had bartered their independence. If we glance at England in this period, which followed hard on Bannockburn, we find commerce and manufactures still in their infancy, wool the staple export, houses of mud in the streets of the cities, and rushes strewn in the king's chamber; but the nation had now its constitution complete, and was moving in the broadening path of freedom. The condition of Italy was in sharp contrast to all this. Trade and manufactures were flourishing, art and literature were encouraged at the courts, and freedom was forgotten in present comfort and inglorious well-being. The result of the self-indulgent policy now begun was seen two centuries later, when Italy lay helpless beneath the feet of contending foreign armies.

The 14th and 15th centuries witnessed the division of Italy among five principal powers—the kingdom of Naples, the duchy of Milan, the republics of Florence and Venice, and the papacy. In Naples the Angevin line came to an end in 1435 with Joan II. She was succeeded by Alfonso V. of Aragon, and the Two Sicilies, separate since 1282, were again united. At his death in 1458, however, Sicily remained to the kings of Aragon, while Naples was bequeathed to his natural son. In Milan the powerful Visconti dynasty survived till 1447. Archbishop Gian Visconti, who died in 1354, made himself master of more than twenty cities, and extended the family's power over the greater part of Northern Italy; and these domains were reunited by his grand-nephew, Gian Galeazzo, who purchased the title of duke, made himself lord as far as the borders of Venice, and was threatening Florence when the plague carried him off in 1402. The Visconti's possessions were confined within narrower limits under his son Filippo, and were seized in 1450 by Francesco Sforza, a famous general, who had married Filippo's natural daughter, and who proved a wise and able ruler. Florence had submitted in 1342 to a despot in Walter of Brienne, the titular Duke of Athens; but this soldier of fortune was expelled in 1343, and the city was ruled until 1434, except during a brief

revolution, by an oligarchy. The presidency of the republic—practically the dictatorship—was then secured by Cosimo de' Medici, who for this end had courted the good-will of the common people; and his undefined power passed at his death in 1464 to his son, and reached its culmination under his famous grandson, Lorenzo the Magnificent. Florence was already mistress of great part of Tuscany, and Cosimo's alliance with Francesco Sforza helped to secure her position as one of the five great powers. Venice, which had until this period stood aloof from Italian politics, was in the hands of a hereditary grand council. Thirty years of contest with Genoa for supremacy in the Mediterranean had ended in victory for the republic of St Mark in 1381. The capture of Constantinople by the Turks in 1453 made Venice, who had been gradually stripped of her possessions in the Levant, now at last an Italian state; and her territory on the mainland was greatly extended under Francesco Foscari (1457) and his successors in the dogeship, although in 1477 a Turkish army ravaged her fields to within sight of St Mark's. Rome, except during Rienzi's brief rule, had obeyed her bishops, exiled at Avignon. In 1377 the papacy returned from the Babylonish captivity, and, in spite of the weakness caused by the Great Schism, the spiritual sovereign also was soon found among the despots. The schism ended in 1449, and Nicholas V. was enabled to establish firmly the temporal power of the papacy.

Italy now enjoyed a term of prosperity and comparative peace, broken only as Venice enlarged her borders, or by the family ambitions of the popes. But in 1494 Charles VIII. of France was induced by the Milanese regent, Lodovico Sforza, to invade Italy, and had himself crowned king of Naples. Meanwhile, Lodovico had murdered and succeeded his nephew, and he now raised Lombardy against Charles, who with difficulty got back to France in 1495. He had caused the expulsion of the Medici, and Florence was again a republic, in which for a time Savonarola's influence was all-powerful. But, of more consequence than this, Charles's expedition had shown the way to others, and inspired an ambition which, under his immediate successors, cost France dear. In 1499 Louis XII. subdued Milan; in 1501 Ferdinand the Catholic tricked him out of Naples, which the two had joined to conquer, and once more united the Two Sicilies under one crown.

The century thus begun is the most disastrous in Italian history. In Northern and Central Italy the French armies held their own against the pope and his allies until the year 1512, when their young general, Gaston de Foix, fell in victory before the walls of Ravenna. They were then expelled for the moment; but Italy had no long rest. The rivalry of the Emperor Charles V. and Francis I., which makes the principal part of European history during this period, filled the land with the clash of foreign arms; while her own rulers, striving each to snatch an advantage from the confusion, added to the country's distractions. The papacy was a gainer from the struggle. The conquests of the Borgias passed to the holy see; and Julius II. succeeded in humbling Venice, and then in driving the French out of Lombardy in 1512. In 1515 Francis regained Milan, but in 1521 his forces were expelled from Italy by the emperor, and in 1525 the French king was taken prisoner at Pavia. In 1527 occurred the sack of Rome by a body of troops of the empire, Lutherans and Spaniards. The Constable de Bourbon, who had led them, was killed in the assault, and the sack continued for seven dreadful months. In September the Medicean Clement VII., who had fled to the castle of St Angelo, was compelled by hunger to surrender.

The Medici, who had returned to Florence in 1512, were again driven out, but were restored by arms in 1530. Alexander de' Medici received from the emperor, who was his father-in-law, the title of duke; and in 1570 Cosimo, his successor, was made Grand-duke of Tuscany by the pope. By the peace of Cambrai (1529) Charles had been left master of Italy; his son Philip became its undisputed lord by the peace of Cateau-Cambresis (1559), though Venice really, and Genoa, Lucca, and the little republic of San Marino nominally, remained independent. Besides Tuscany, there were the duchies of Modena and Ferrara and of Parma and Piacenza, and the rich States of the Church; Spain herself held all the rest of Italy, save Piedmont, which was restored to the dukes of Savoy in the person of Philip's cousin and general, Emmanuel Filibert. This prince also regained Savoy and the province of Nice, which his family had lost; but he removed his capital to Turin, and his house was henceforth Italian. The papacy had been strengthened by the founding of the Jesuit order in 1540, and the establishment of the Inquisition; and the Council of Trent (1545-63) defined the Catholic faith. The territory of the church was further augmented by the absorption of several lapsed fiefs, and the supremacy of the pontiffs was now acknowledged by Venice, who had hitherto recognised no superior to her own patriarch. But Venice was no longer the great state she had been. Her commerce had fallen off since the discoveries of Columbus and Da Gama, and most of her conquests were in the hands of the Turks, to whom, in spite of the victory of the allied fleet at Lepanto (1571), she had been compelled to give up even Cyprus. Her last great achievement, in a war that she had waged at intervals for five centuries, was the conquest of the entire Peloponnesus, in 1684; but in 1715 this fell again into the hands of the infidels. The power of Spain, too, had greatly declined, and besides Masaniello's revolt at Naples (1647) there were risings in Sicily, which gave the island to Louis XIV. for two years. But throughout this period, and until as late as the 19th century, Italy was disposed of by foreign powers, and partitioned as suited their policy. After each of the three European wars of succession, in the 18th century, Italy was subjected to a fresh re-division; but it is not necessary to notice more than the last of these in detail. The services rendered by the House of Savoy against the French, during the war of the Spanish succession, won for it the island of Sicily and the title of king. The new monarch, Victor Amadeus II., was one of the liberal and enlightened despots of the time; and although in 1720 he was compelled to exchange Sicily for Sardinia, from which island his successors took their title until 1861, he built up a real kingdom, took the schools away from the Jesuits, and did much to promote the welfare of his subjects. The last war, that of the Austrian succession, in which the Sardinians fought gallantly on the Hapsburg-Lorraine side, ended with the treaty of Aix-la-Chapelle (1748), which left Italy divided as follows: the House of Savoy held Sardinia and Piedmont, with Montserrat and Alessandria, Tortona and Novara; the Austrians retained Milan and Tuscany; the Bourbon Charles III. was king of the Two Sicilies, and his brother Philip, Duke of Parma; the papal territory stretched across the centre of the peninsula to the frontiers of Venice, which survived as a republic until 1797; and finally, Modena and Genoa were placed under the protection of France, to whom the Genoese ceded the island of Corsica in 1755. Italy now enjoyed a brief period of freedom from wars; but her numerous sovereigns were absolute, each within his petty domain, and the despotic policy of

the Bourbons, who held nearly all the country, was generally adopted. An honourable exception was Peter Leopold, who was Grand-duke of Tuscany from 1765 until he succeeded to the Austrian empire as Leopold II. in 1790. He instituted many reforms, restricted the power of the priesthood, and suppressed the Inquisition; and to him is owing the reclamation of the fruitful Val di Chiana from a wilderness of pestilent marsh. To the rule of this prince the harsh, jealous oppression of the other sovereigns presents a pitiful contrast. For Italy the long reign of misery and darkness was at last about to pass away—but slowly; the night was not yet past.

The storm of the French Revolution burst in 1792. In 1796 Napoleon entered Italy; in 1797 the Cisalpine, Ligurian, Cispadane, and Tiberine republics, with their capitals at Milan, Genoa, Bologna, and Rome, were formed out of Northern and Central Italy, and Venice and her territory beyond the Adige were bestowed on Austria. The next year Naples surrendered, and was made the capital of the Parthenopean Republic. The democrats in the cities joyfully welcomed the new doctrines brought by the invading army; but even they soon wearied of a nominal freedom that bestowed chiefly the privilege of sharing the heavy costs of the French wars, and in 1800 Napoleon had to win the peninsula afresh by the victory of Marengo. In 1804 he made himself emperor, and in 1805 he was crowned king of Italy at Milan. The Bourbons were permitted to retain Tuscany and Naples, and the pope was reinstated in the possession of Rome. Naples, however, was given to Joseph Bonaparte in 1806, and to Joachim Murat in 1808; in 1809 Rome was annexed to the French empire, and the emperor's sister Eliza was made Duchess of Tuscany. The Congress of Vienna (1815) restored the map of Italy very much to its former appearance; but the advantages of the new distribution fell nearly all to the House of Austria. Venice was added to the Austrian crown, and Lombardy retained; an Austrian duke was set over Modena; and the Austrian Ferdinand III. received back Tuscany, to which Lucca was to be added whenever the death of Napoleon's Austrian wife, Maria Louisa, should give Parma again to its former Bourbon masters. The only other lasting change was the transference of Genoa to Victor Emmanuel I. of Sardinia. Naples and Sicily were restored to the Bourbons, and the pope was once more put in possession of the States of the Church. The little republic of San Marino was also recognised by the congress.

A period of absolutism and rigid repression now ensued. The returned princes adopted in full the policy dictated from Vienna, and strove by all means to crush the rising spirit of independence. The Jesuits, whose order had been suppressed by the pope in 1773, were restored and the elementary education placed in their hands, where it was effectually strangled. The legions of Austria filled Lombard-Venetia, and were at the service of all the petty despots in the other parts of Italy; while a yet larger army of spies was at work in every corner of the unhappy country. The general misery provoked conspiracy, and the revolutionary Carbonari societies sprung up everywhere. But the movement had as yet no directing head. There were risings in Southern Italy in 1820, but they were suppressed in the following year, and the leaders executed; and numerous less important insurrections there, in the period preceding 1846, were easily put down. Other abortive attempts were made in Piedmont, in Lombardy, in Modena and the Romagna, the only result of which was to make the rulers' hands yet heavier on the people. Nor was there thorough unanimity or common

action among Italian liberals. The extreme republicans, represented by the party of Young Italy, were headed by Mazzini, whose fiery eloquence and enthusiasm transformed the vague desires of his countrymen into a passionate hope; but his policy sanctioned methods from which more sober patriots shrank. From Geneva he led a band of refugees to the invasion of Savoy, in 1833, because the new king, Charles Albert, would not enter on a war with Austria; but this wild raid proved an utter failure. Already the wiser minds in Italy looked to Sardinia for deliverance; but the dream of a confederacy, with perhaps the pope as president, was not yet dispelled. Nay, it seemed about to be realised when, in 1846, Pius IX. assumed the tiara, and initiated a series of liberal reforms. Constitutions were granted in 1847 by all the rulers save Austria and Ferdinand II. of Naples; and from the latter a constitution was wrung in the following year. The year of revolutions, 1848, opened with a street massacre by the Austrians in Milan, on 2d January. In February the French Republic was declared, and then in Italy the party of Mazzini was for a moment supreme. Sicily revolted from Ferdinand, and in March Charles Albert declared war on the Austrians, who had been driven out of Milan and Venice. He passed the Ticino, and defeated Radetsky at Goito; but on 25th July the Austrians won the decisive battle of Custoza, re-entered Milan, and placed the country under martial law. In Naples there had been a massacre in May, and on 30th August Messina was bombarded. Meanwhile the pope's heart had failed him. His troops had gone to the help of the Sardinians, but before their surrender he had declared their advance to have been without his leave. The republicans, who had regarded his liberal measures with suspicion and jealousy, now denounced him as a traitor to the cause of Italian freedom. On 15th November his wisest minister, Count Rossi, was assassinated, and Pius fled to Gaeta in disguise. A republic was set up in Rome on 9th February 1849, under Mazzini and two other triumvirs. The Grand-duke Leopold had fled from Florence, but Tuscany refused to join herself to the republic; yet when the sovereign she had invited back returned, his first act, supported by the presence of Austrian troops, was to suppress the constitution. In Piedmont the ultra-radicals, headed by Rattazzi, were now in power, and a fresh campaign against Austria was begun—this time lasting less than four days. On 23d March Radetsky defeated the Piedmontese at Novara. Charles Albert gave up his throne to his son, Victor Emmanuel II., and died, broken-hearted, at Oporto four months later. Efforts were now made to reduce Rome and Venice. In vain did Garibaldi, who had been called to the defence of Rome, defeat the Neapolitans at Palestina and Velletri. A French army, under General Oudinot, took the city, after a four weeks' siege, on 2d July. Venice, under the heroic Daniel Manin, bravely kept her enemies at bay until 22d August. The petty sovereigns now came back—the pope last, in April 1850. Rome, occupied by a French garrison, was kept in a state of siege for seven years, and the city never quite recovered its freedom until 1870. Italy's first general effort for freedom had ended in failure: 1848 was a year of unfulfilled visions. But one important gain was effected: the dream of federation was ended, and all men looked now to the House of Savoy, save the few idealists, like Mazzini, who afterwards stood sternly apart from the triumph of compromise.

Victor Emmanuel was faithful to the Italian cause, and persevered in the path of reform on which his family had entered. Sardinia was relieved, by the law which gave the government

power to abolish monasteries, from the incubus of an army of idle and ignorant ecclesiastics; a liberal constitution was in force, the press was free, education was spreading, and a measure of religious liberty was enjoyed. In 1853 the Sardinian prime ministry passed into the hands of Cavour, the brain, as Garibaldi was the arm, of the coming struggle. Henceforth he inspired and guided the national movement, until his death in the moment of victory. The Sardinian troops, reorganised by La Marmora, were sent under that general to the Crimea, where they won for themselves honour, and for their country allies amongst the great powers. Cavour made terms with Louis Napoleon, and in 1859 war was declared once more against Austria. The French and Italians won the battles of Magenta and Solferino in June, and then the French emperor, acting independently, agreed to a treaty which left the Austrians in possession of Venetia, from the Mincio eastward. The indignation of the Piedmontese, whose sovereign had, under Cavour's agreement with Louis Napoleon, to give up Savoy and Nice in return for this assistance, was intense; but the states of Central Italy voted their union to the kingdom of Victor Emmanuel, and were annexed in March 1860; and a few days after Southern Italy revolted from Francis II., the son of Ferdinand, the detested Bomba. Garibaldi and his volunteers, their expedition secretly favoured by Cavour, went to the support of the insurrection in May, and in September entered Naples. Cavour, with the consent of Louis Napoleon (who, however, maintained the pope in Rome, because his own position in France was strengthened by his championing the head of the Catholic Church), now sent an army into the papal states, which defeated the pope's troops at Castellidardo, joined Garibaldi, and helped him to defeat the Neapolitan generals on the Volturno. In October Victor Emmanuel entered the Abruzzi, and Garibaldi resigned his dictatorship and retired to his island farm. In February 1861 the first Italian parliament met at Turin, and Victor Emmanuel was proclaimed King of Italy. But Rome and Venice were not yet freed, and Cavour died in June of this year. In 1862 Garibaldi raised a body of volunteers to liberate Rome, and, having crossed to the mainland, was defeated at Aspromonte; the blame, however, fell chiefly on Rattazzi, who was then minister, and who had sought to follow Cavour's policy, and to reap the advantage of Garibaldi's expedition, but had neglected to first come to an understanding with France. The expressed sympathy of Europe brought about the September Convention of 1864, by which Louis Napoleon agreed gradually to withdraw the French troops on Italy's stipulation not to allow an attack on the pope's territory. By the last article of the convention, the capital was removed a step nearer Rome—from Turin to Florence. In 1866 the Austro-Prussian war, in which Italy took but an inglorious part as the ally of Prussia, added to the kingdom the coveted territory of Venice. In the same year the French garrison was withdrawn from Rome, and Mazzini demanded that the city should be captured. In 1867 Garibaldi and his volunteers gained a victory near Rome, and the French returned; the volunteers surrendered in November, and the general was arrested. But after the fall of the empire, in 1870, the new foreign minister of France, Jules Favre, declared the September Convention at an end, and the king, who had only prevented the democrats from moving by arresting Mazzini, was at length free to act. On 20th September he entered Rome, and the emancipation of Italy was completed. The pope retained the Vatican, the church of Sta Maria Maggiore, the Lateran palace, the villa of Castel Gandolfo,

with their precincts, and was voted an income of £150,000 out of the revenues of the state; yet the spiritual sovereign has borne but impatiently the loss of his temporal power, and frequent complaints and denunciations have been directed from the Vatican against the palace on the Quirinal. Meanwhile Italy, at last free and united, has become one of the great continental powers, as has been shown in the preceding sections of this article. It will be the hope of all who have followed the story of her long degradation and gallant recovery of freedom that this rapid growth may not, like her earlier precocious development in arts and commerce, be bought at the after cost of premature decay.

The later history of Italy has been uneventful. Brigandage, rife under the tyrannical rule of the Bourbons, and afterwards encouraged by their emissaries, has been gradually suppressed, education and public works have steadily advanced, and in the south the people have become more reconciled—at least, less inveterately hostile—to the laws. In January 1878 Victor Emmanuel died, and was succeeded by his eldest son, Humbert I. (born 1844); and one month later Pius IX. died also, and Leo XIII. became pope. The most important internal measures since then have been the wide extension of the franchise and the adoption in 1882 of the system of *scrutin de liste*, and in 1883 the resumption of specie payment. The popular interest in political questions so far is not great; but the government has been from time to time embarrassed by the agitation conducted by the extreme party of Irredentists, whose professed aim is to add to the kingdom all those districts of Europe where the Italian speech prevails. These, which they have named *Italia Irredenta* ('Unredeemed Italy'), embrace the southern Tyrol ('the Trentino'), Görz, Trieste, Istria, and Dalmatia, and also the Swiss canton of Tessin (Ticino), Nice, and the islands of Corsica and Malta; but it is mainly against Austria that the hatred of the Irredentists is directed. In 1883 the ministry denounced the schemes of the association, as aiming indirectly at the downfall of the monarchy, and at the same time extolled the triple alliance (of Italy, Germany, and Austria), into which Italy, exasperated at the extension of French influence in Tunis, had entered. To this same jealousy of France's encroachments on the southern Mediterranean shore may be attributed the erection into an Italian colony, in 1882, of a coaling station founded the year before at Assab, on the Red Sea. In 1885 Massowah was occupied, and in 1889 the Italian colonial territory was amalgamated under the name of Eritrea (see p. 240). Abyssinia had come to be looked on as under an Italian protectorate, but difficulties accumulated until in March 1896 an Italian force was routed at Adowa by the Abyssinian king. In the same year a treaty was concluded with France about Tunis; and the heir-apparent married the daughter of the Prince of Montenegro. In the early morning of 29th July 1900 King Humbert was assassinated at Monza by Angelo Bressi of Prato in Tuscany, and was succeeded by his son, Victor Emmanuel III.

The principal materials for Italian history during the middle ages will be found in Muratori's *Rerum Italicarum Scriptores* (25 vols. 1723-51; useful 'Indices Chronologici' appeared in 1885), and in the *Archivio storico Italiano* (vols. i.-xvi. 1838-51). See also Guicciardini's *Istoria d'Italia*, continued to 1814 by Carlo Botta; Muratori's *Annali d'Italia*; Cesare Balbo's *Sommario*; Bryce's *Holy Roman Empire*; and Villari's *Storia politica d'Italia* (8 vols. 1883 *et seq.*). Among books dealing with separate periods may be mentioned Hodgkin's *Italy and her Invaders* (from the fall of the empire; volumes i. to vi. 1880-91); Sismondi's *Republiques Italiennes du Moyen-âge*; Troya's *Storia d'Italia del*

Medio Evo (17 vols. 1839-59); Reuchlin's *Geschichte Italiens von der Gründung der römischen Dynastie* (4 vols. 1859-73); Maurice, *The Revolutionary Movement of 1848-49* (1887); and Nisco's *Storia civile*. Symonds's *Renaissance in Italy* is valuable, and Von Ranke's *History of the Popes* is necessary to a proper understanding of the national development. Finally, there is a useful little volume on Italy, by W. Hunt, M.A., in Professor Freeman's 'Historical Course.' Reference should also be made to the articles on the separate provinces and the great cities (Rome, Florence, Naples, Venice, &c.), and to the works cited there; and also to the numerous articles in this Encyclopædia on the principal characters in Italian history—from Odoacer to Cavour, Garibaldi, Mazzini, &c. See also ART, DRAMA, PAINTING, RENAISSANCE.

LANGUAGE AND LITERATURE.—Italian is one of the group of Neo-Latin or Romance languages—viz. languages the direct offspring of the Latin tongue as spoken by the Romans and imposed by them on the nations more immediately under their dominion. The chief subdivisions of the Neo-Latin group are French, Spanish and Portuguese, Provençal, Rumanian, and Italian. This last retains the closest resemblance to its prototype. The affinity between the Romans and the races of the Cisalpine Peninsula being closer than in the case of the other Latinised peoples, the phonetic changes introduced by them are less profound. The question as to whether the Neo-Latin idioms were much modified by the frequent Teutonic invasions of south-western Europe has given rise to prolonged discussion among philologists; but more recent methods of research seem to establish the fact that the influence of these invaders was slight, the more perfect language of the vanquished having imposed itself on the intellectually inferior conquerors. Neither is modern Italian derived entirely from the so-called 'rustic Latin,' or incorrect speech of the lower orders. The origin of the words which compose the modern tongue may be traced in as many cases to the speech of Cicero and Virgil as to that of the common folk. The differences between the ancient and modern languages are the outcome of the natural evolution of all living organisms which must undergo such changes as are necessary to life and growth. But so overwhelming was the prestige of Latin literature that this natural evolution was looked on with contempt by the learned everywhere. The struggle between the written but dead language and the various forms of the living speech was nowhere so protracted as in Italy, where the influence of Roman traditions and culture was supreme.

During this long period of evolution many dialects sprang up which still preserve their individual peculiarities. The conformation of the peninsula, its varying climates and soils, and the different origins of the races which inhabit it account for the variety and differences of these dialects. Their seemingly wide divergences are in reality mostly caused by pronunciation and not by structural changes. According to the classification of Guix (in his admirable study *Sui Dialecti d'Italia*), their principal divisions are: (1) In the north and north-west the *Gallio-Italian*—viz. Piedmontese, Lombard, and Emilian or Bolognese, in close affinity to the French in their mode of pronunciation and truncated terminations; (2) the *Venetian*, spoken also in the Italian Tyrol and parts of Dalmatia and Istria. This dialect is soft, harmonious, and more purely Italian. The subdivision of it is the Friulian, which preserves a close resemblance to the ancient Rhetian. (3) In the centre the pure *Italian* dialects—viz. Tuscan, Roman, with the nearly-related dialects of Umbria and the Marches, Campanian, in which Abruzzese and Apulian are included. (4) In the south and south-west the *Ibero-Italian*—viz. Sicilian, spoken also in the extreme south

of Calabria and part of Sardinia; Corsican, Sardinian, and Ligurian, or the dialects of the Genoese sea-coast. This last group presents marked traces of the close commercial intercourse with Spain and her long dominion in these parts of Italy.

As early as the 11th century the earlier-matured idioms of France and Provence had already taken shape in an abundant literature of their own which invaded the Italian peninsula, and the much-admired poetry of the troubadours threatened to stifle entirely the humbler growth of the soil. However, in the early part of the 13th century, in the famous centre of social life and culture formed by the brilliant court at Palermo of the Emperor Frederick II. of Hohenstaufen, a school of Aulic (or court) poets sprang up headed by the emperor himself and his friend and secretary, Pietro delle Vigne (died 1249). The Sicilian dialect formed the basis of the idiom used, but the large mixture of Latin words, and the too evident imitation of Provençal models, mark this school of poetry as an artificial product. After the death of Manfred, Frederick's unfortunate son (1266), the Sicilian school soon ceased to exist.

In various parts of the mainland more or less successful attempts were now being made to write in the vulgar dialects. Noteworthy is that of St Francis of Assisi and his followers to use the Umbrian dialects in religious lyrics during the 13th century, the most distinguished among this group being Jacopone da Todi (died c. 1306). The sacred dialogues, a primitive form of the mystery play, produced by this same school, may be regarded as the earliest germ of the national drama. An important group of lyric poets flourished in Bologna, then a centre of European learning and civilisation; their chief was Guido Guinicelli (died 1276), praised by Dante (*Purgatorio*, xxvii.) as the father of himself and all other singers of love. The contemporary Tuscan poets wrote philosophical lyrics full of overstrained sentiment, but in wonderfully pure Italian. Chief among them were Guido Cavalcanti (died 1300), the beloved friend of Dante, and the immediate precursor of the latter's lyric style; and Cino da Pistoia, a distinguished jurist-consult and admired sonnet-writer, whose death (1336) was bewailed in verse by the young Petrarch. Fra Guittone d'Arezzo (1215-91) and Francesco da Barberino (1264-1348) wrote didactic allegorical poems and songs; the epistles of the former are noteworthy as the earliest prose writings in the vulgar tongue. Among the leading political and learned men of Florence was Brunetto Latini (1210-94); his best-known work is *Il Tesorotto*, a kind of allegorical encyclopædia in verse, showing immense erudition. Dante speaks of him as his instructor and master (*Inferno*, xv.). To this time belongs the earliest important collection of prose tales, the *Cento Novelle Antiche*, collected by an anonymous but probably Florentine writer. It is in Tuscany, in the central zone of the peninsula, that the idiom at last takes definite shape in which the varied dialects of north and south are to find their representative type. The man who is to harmonise in a great masterpiece these varied elements of style and language, and to reveal to Italy and the world all the power and compass of the living speech, growth of his native soil, is the Florentine Dante Alighieri (May 1265-1321). Dante's supreme poetic genius and the strength and individuality of his noble character made his influence as great among his contemporaries as it has continued to be through all succeeding ages. Almost contemporary with Dante, and forming with him the triumvirate which makes the 14th century, or 'Trecento,' the golden age of Italian literature, stand Petrarch (1304-74) and Boccaccio (1313-75). Thus Italian

literature presents the strange phenomenon that it attains its zenith in its opening period. Petrarch, the precursor of the revival of classic studies which was to give the distinguishing mark to the following century, lives in fame, not by his voluminous Latin works, but by reason of the unequalled beauty of his songs and sonnets written in the despised idiom of the people. If we may say of him that he brought to perfection the language of lyric poetry, so may Boccaccio have the honour of giving form to prose by the language in which he clothed his tales. Around this imposing trio are grouped many lesser stars whose works, though inferior as to substance, are all distinguished by the same simple beauty of style. Francesco Stabile, known as Cecco d'Ascoli, is the author of a strange, semi-scientific poem, *L'Acerba*, in which he severely censures Dante's *Divine Comedy*. He was professor of Astrology at Bologna, and was burned for heresy in 1327. The Florentine Fazio degli Uberti produced, in imitation of the *Divine Comedy*, a long poem, *Il Dittamondo*, a wearisome versified account of imaginary travels; more successful were his graceful lyrics. The imitators of Petrarca during this century are of little importance, the most noted being Giusto da Valmontone (died 1449), author of a collection of lyrics, *La Bella Mano*. Among Boccaccio's followers are Ser Giovanni Fiorentino, author of a collection of tales called *Il Pecorone*, written about 1378, and the more original Franco Sacchetti (1330-99), who gives in his book of anecdotes a familiar and spirited picture of contemporary customs.

The earliest undoubtedly authentic historical work in Italian is the *Chronicle* written by Giovanni Villani, a leader in the commercial and political life of Florence, whose history he relates with vigour and simplicity. He died of the plague (1348), but his chronicle is continued till 1364 by his brother and nephew. The important *Cronaca dei suoi tempi*, by Dino Compagni, describes minutely the party strife in Florence (1300-1). Especially noteworthy for their graceful and pure diction are the letters of the famous St. Catharine of Siena (1347-80), and the *Fioretti* of St. Francis, a selection by an anonymous author of the sayings and doings of that holy man and his followers.

Though classic antiquity was naturally the source of all culture during the 14th century, still the great men of that age drew their more immediate inspiration from the religious and political movements of their day. The distinguishing mark of the 15th century, on the other hand, is the withdrawal of the cultured class from interest in popular events, and their contempt of the national language for literary uses. Latin becomes the only acknowledged literary medium. For a more detailed account of all the celebrated Humanists and their various patrons, see Symonds's *Renaissance in Italy*, and Roscoe's *Lorenzo the Magnificent* and *Leo the Tenth*.

This great revival or 'Renaissance' of Greek and Roman culture, which from Italy outwards affected the whole of Europe, was fostered by the splendid protection of the numerous princes whose rule was now gradually taking the place of the turbulent but life-inspiring freedom of the small republics. These patrons and their erudite courtiers have conferred a lasting benefit on posterity by the priceless libraries in whose collecting they vied with each other. Foremost amongst artistic and literary centres was Florence, under her Medici rulers, Cosimo, called Pater Patriæ, and his grandson, Lorenzo the Magnificent, who were the first also to encourage a return to the use of the vulgar tongue among the distinguished writers of their court. Leon Battista Alberti (1406-72) was one of the most zealous advocates for the restoration of

Italian. A wonderfully versatile genius, he excelled as architect, poet, and prose-writer both on art subjects and moral philosophy; his most important Italian work is a treatise 'On the Family,' of which the well-known dialogue on the same subject ascribed to Agnolo Pandolfini is supposed to have formed part. Angelo Politian (1454-94), one of the most brilliant ornaments of this court, wrote an exquisite eclogue, *L'Orfeo*, the first secular drama in Italian, although the *Canto Carnascialesco*, or rhyming dialogues sung by masqueraders at carnival time, may be considered an earlier form. Side by side with these are the friends Pico della Mirandola (1463-94), who has, however, left little but the fame of his vast erudition, and Girolamo Benivieni, author of much didactic and devotional poetry, which reflects the teachings of the great reformer and orator Savonarola, the opponent of Pagan culture, whose influence was supreme in Florence from 1489 till his execution in 1498. The two Florentines, Giovanni Rucellai (1475-1526) and Luigi Alamanni (1495-1556), wrote graceful poems in imitation of the Georgics. The revival of classic rhythms, attempted by Claudio Tolomei, has been more successfully carried out in modern times by Carducci (q.v.). In Naples a brilliant school of Latin poets flourished. Pontano (1426-1503) enjoyed much contemporary fame and influence; his more celebrated follower, Jacopo Sannazzaro (1458-1530), is remembered by his pastoral romance, with lyric interludes, *Arcadia*, written in Italian.

But the popular and typical product of this age is the narrative poem, or romantic epic. Rude translations of chivalrous poems from the French and Provençal had long been in use among the populace; the first, however, to ennoble the narrative poem was the Florentine Luigi Pulci (1432-84). His style is comparatively simple and free from Latinisms, and one of the distinctive marks of the romantic school in his work, as in all other literatures, is the breaking down of the classic barrier between the serious and the humorous. Contemporary with him was his more famous competitor, Matteo Boiardo (1434-94), an adherent of the dukes of Ferrara. To the same brilliant court belonged the famous Ariosto (1474-1533), who brought to perfection the romantic epic. In close connection with this new school are the burlesque-writers of the early 16th century. Most polished of these was Francesco Berni (1497-1535); he lived in the service of the Medici popes, and is said to have died of poison given by order of the notorious Duke Alexander de' Medici. Florence was the special home of these flippant and licentious poets, whose wit gave expression to the all-pervading scepticism and corruption of the age. Antonio Francesco Grazzini, called Il Lasca (1503-84), was the most brilliant of the 'Bernesque' imitators. He excels also as a writer of prose tales in the style of Boccaccio, while his contemporary, Matteo Bandello (c. 1480-1562), is the chief story-teller in Lombardy. A strange variety of serio-comic verse is that written in 'Lingua Macaronica,' or burlesqued Latin, by a monk of Mantua, Teofilo Folengo (1492-1544), under the pseudonym of Merlino Cocajns. Now mere literary curiosities, these humorous poems were immensely popular in their day.

In the 15th century the corruption and dissensions of her many rulers had reduced Italy to a state of dissolution, which left her an easy prey to foreign invaders, and the 16th century saw the completion of her political ruin. Her literature is trammelled by classic imitation and court servility. A corroding cynicism and want of moral sense are the characteristic note of the greatest writers, foremost among whom is Machiavelli (1469-1527); but his great genius and far-seeing patriotism redeem

his defects and ennoble his work. Next to him as historian comes his fellow-citizen, Francesco Guicciardini (1483-1540), who is a model of order and elegance. Every court in Italy had its chroniclers, but many of them wrote in Latin. Among these the most quoted is Paolo Giovio (1483-1552), attached to the papal court for many years.

The secret despatches of the Venetian ambassadors to their senate, from 1500 onwards, form a copious store of vivid and accurate historic information. Paolo Paruta (1540-98) has written a remarkable history of Venice. The growth of the secular drama was rapid at this time. Moulded entirely on classic models as to form, comedies now begin to represent living types and customs, while the tragic style remains stilted and artificial. The great names of Machiavelli and Ariosto are foremost amongst these comedy-writers. Full of wit and originality, mixed with obscenity, are the comedies of the infamous Pietro Aretino (1492-1557), whose celebrated Letters were used by him as a means of blackmailing the princes whom he attacked. One of the most applauded and licentious comedies was written by the Cardinal Dovizi di Bibbiena (1470-1520), *La Calandria*, and represented before Pope Leo X. In the didactic works *Il Cortigiano* of the Mantuan Castiglione (1478-1529), and the *Galateo* of the Tuscan G. della Casa (1503-56), we have models of elegant prose, which preserve for us pictures of the court-life of the times. The learned Cardinal Bembo (1470-1547), who during his lifetime gave the law in all matters of literary taste, did much by example and precept to help in the restoration of the vulgar tongue.

Two biographers are especially famous. Giorgio Vasari (1512-74), himself an indifferent artist, has left us a precious mine of information in his much-quoted *Lives of the Artists*; and unique of its kind is the graphic and picturesque autobiography of the great artist, Benvenuto Cellini (1500-71).

The end of the 16th and beginning of the 17th centuries saw political and religious liberty in Italy crushed under the dominion of the foreign invaders, and the increasing power of the popes. It is an age of decadence in art and literature, language is pompous and verbose, and the themes treated unreal. One name of enduring fame illumines this period, that of the unhappy Tasso (1544-95), a pure and earnest genius, and with him ends the pre-eminence of Italian literature in Europe. The pastoral drama, perfected by Tasso in his *Aminta*, and by his rival Guarini (1537-1612) in his *Pastor Fido*, became widely popular. In 1594 the *Dafne* of Rinuccini was produced with music, the earliest specimen of the musical drama.

The prolixity of description and abuse of metaphor, already in vogue towards the end of the 15th century, grew to such heights in the 17th century that 'Seicentismo' has remained a synonym for all that is false and exaggerated in style. The Neapolitan Giambattista Marino (1569-1625) is the leader of this school. His great poem, *Adonis*, amid all its grave defects, shows a powerful imagination and masterly ease in versification. Among a crowd of mediocre and servile lyricists, the Florentine Vincenzo Filicaja (1642-1707) is noteworthy for dignity and patriotic feeling. Gabriello Chiabrera of Savona (1552-1637) and his followers, Fulvio Testi of Ferrara (1598-1646), and Francesco Redi of Arezzo (1626-98), imitated with success the Greek lyricists. The imitations of Tasso's great epic were less successful than the parodies. A mock-heroic masterpiece is *La Scerchia Rapita* ('The Stolen Pál'), by Alessandro Tassoni of Modena (1565-1638). Of a less playful humour are the satires of the well-known Neapolitan artist, Salvator Rosa

(1615-73), conspirator with the famous Masaniello against the Spanish oppressors. The greatest names of this age belong to science. The writings of the foremost of all, Galileo, are models of clear exposition and choice diction. The works of the advanced thinkers of the time, nearly all natives of Southern Italy, and the best known amongst whom is Giordano Bruno (c. 1550-1600), belong to the history of philosophy. Venice still cherishes the name of Fra Paolo Sarpi (1550-1623), the scientist, historian, and opponent of Jesuit doctrines.

The dawn of the 18th century shows a dull level of mediocrity, and a false and affected literary taste, which the authority of the Roman 'Academy of Arcadia' did much to foster. Opponents of the prevailing fashion were the Venetians, Gasparo and Carlo Gozzi, the latter (1722-1806) being especially remembered by his graceful dramatised *Fable*. The more important Lombard poet, Giuseppe Parini (1729-99), writes with simple elegance in his satires. Most admired of his own contemporaries was the dramatic poet, Pietro Trapassi, known as Metastasio (1698-1782), poet-laureate and favourite at the imperial court of Vienna; but much greater is now the renown of his contemporary Goldoni (1707-93), who, by a return to the study of popular life and existing surroundings, became the reformer of the stage. To the end of this century belongs also Alfieri (1749-1803), the only great tragic writer whom Italian literature possesses. Roused to a hope of liberty by the great Revolution, Italy was again plunged into despair after the fall of Napoleon by the loss of the semblance of unity which had been given her, and, animated by hatred of the petty tyrants who returned to rule her, she began the long struggle for freedom. All the eminent literary men of this period helped the patriotic cause with their pen, and many suffered exile and imprisonment.

The talented Vincenzo Monti (1754-1828) was the leader of a new return to classic models in his eloquent and flowing poems. Pindemonte (1753-1828) is a noted follower of this school, and the more famous Ugo Foscolo (1778-1827). The most illustrious of the classicists is, however, Leopardi (1798-1837), the greatest Italian lyricist since the days of Petrarca. The tragedies of G. B. Niccolini (1782-1861), full of fiery patriotic allusions, were immensely popular. This classic school in turn gave place to the romantic. The centre of this movement was Milan, and its chief Manzoni (1785-1873), whose *Promessi Sposi* is the only really great historical novel in Italian. Two other noteworthy historical novelists are F. D. Guerrazzi (1804-74), who took a leading part in the Tuscan revolution of 1848; and Massimo d'Azeglio (1798-1865), one of the foremost political men of his time. More modern and original in style is the interesting novel, Nievo's *Confessione di un Ottomannico*.

Silvio Pellico, who has written many dramas, is better known by the touchingly natural account of his imprisonment by the Austrians. The romantic school produced no remarkable lyrics but those of Manzoni himself, and, although all over Italy fervent poets sang of freedom, only the satires of the Tuscan Giusti are of permanent value. The more noted of these minor poets are Berchet, Prati, Alardi, Paerio, and Gabriel Rossetti, connected with English literature through his illustrious children. Belli in Rome, and Porta in Milan, are noted poetic writers in dialect. The *Summary of the History of Italy*, by Cesare Balbo (1789-1853), the *History of the Florentine Republic*, by Gino Capponi (1792-1876), the *Universal History*, by Cesare Cantù (born 1807), are noticeable works. Rosmini (1797-1855), Gioberti (1801-1852), Mamiani (1800-85) are well known metaphysical and theo-

logical writers. Niccolò Tommaseo (1802-1874) is noticeable among critics and essayists for the vast extent of his learning. The eloquence and purity of style of Mazzini's political writings give them also literary value, and along with him among advanced thinkers must be mentioned Romagnosi (1761-1835).

Since the stormy times of her struggle for life, united Italy has produced few literary works of character and originality. The name of the poet Carducci is the only one of great distinction. Among the minor lyrists are Rapisardi, Guerrini (Stecchetti), and Panzucchi; and the lyrics in Tuscan dialect of Fucini are full of wit and nature. In Naples the talented young Gabriele d'Annunzio, both in poetry and prose, and Matilde Serao and Giuseppe Verga in their novels and stories, belong to the extreme school of realism. In the north the novelists Farina, Barrili, and the more eminent Fogazzaro show moderate tendencies. The vivid *Vita Militare* and other works of E. de Amicis, and the charming *Autobiography* of the sculptor Duprè, are well worthy of notice. Among dramatists, the works of Cossa, Ferrari, Giacosa, and Cavallotti are the most popular. Arrigo Boito, the composer, shows himself in his librettos and other works no mean poet.

The masterly historical works of P. Villari on Savonarola and Machiavelli are well known in translation to English readers. The versatile R. Bonghi has written interesting essays on various historical and political subjects.

For the language, see D'Ascenzi, *Archivio Glottologico*; Caix, *Sulla Storia della Dialectica d'Italia*; Rajna, *Le Origini dell'Epopea Francese*; Littré, *Historia de la Langue Française*; Max Muller, *Lectures on the Science of Language*, No. vi. And for the literature, see Sismondi's *Literature of the South of Europe* (trans. by Roscoe); Hallam's *Literature of Europe*; Adoli Gaspary, *Italienische Litteratur*; Bartoli, *Storia della Letteratura Italiana*; De Sanctis, *Storia della Letteratura Italiana*; Settembrini, *Discorsi sulla Letteratura Italiana*; Carducci, *Studi Letterari* and *Lirici del Secolo XVIII.*; Tabarrini, *Vita e Ricordi di Italiani illustri del XIX. secolo.*

Itasca Lake. See MISSISSIPPI.

Itch, or SCABIES, a skin disease produced by a minute mite (*Sarcoptes scabiei*), which burrows in the epidermis of most parts of the body, but especially about the hands. Its presence is marked by a small scaly elevation of the skin, by eruptions on the papillæ of the cutis are perforated, and by the irritating itching sensation.

The mite itself is white or yellowish, broad and flat, with two pairs of mouth parts, and four pairs of appendages. The males are scarcer and much smaller than the females, which are just visible to the naked eye. When they have entered the skin they do not leave it, but form tortuous burrows, through openings in which the embryos escape. The mites are passed by contagion from person to person, either by direct contact or by clothes or bedding. It is probably the embryos or larvæ which are usually thus transmitted. The above species also occurs on the horse, Neapolitan sheep, and lion; *S. squamiferus* occurs (causing mange) on dogs, pigs, goats, sheep, and apparently also for a short period on man; *S. minor* is also distinguished on cats and rabbits.

The itch was for a while regarded as a specific disease, the mite being unknown. Avenzoar, an



Itch-mite:

Abdominal view of female itch-mite, magnified 65 diameters.

Arabian physician of the 12th century, is said to have recognised its true nature. So does Scaliger (1537); and Adams figures the animal in a paper read in 1805 before the Royal Society. Amid some scepticism as to the mite during the early part of this century, M. Gales hoaxed the public by figuring as a substitute for the itch mite the familiar denizen of cheese. His trick was discovered by Raspail, and the existence of a real mite was more distrusted than ever, till in 1834 Remucci, a Corsican student, again demonstrated its presence and characters. It has been often studied since.

The usual cure for itch is found in baths, with abundant soap, or in rubbing with sulphur ointment. If these be not resorted to, the multiplication of the mite may give more serious trouble.

See ARACHNIDA, MITE, PARASITISM, SKIN; Delafond and Bourguignon in *Mém. Acad. des Sciences* (Paris, 1802); and treatises on Parasites by Leuckart, Küchenmeister, &c.

Ithaca, now THIAKI, one of the Ionian Islands (q.v.), the smallest of them except Paxo, is a long, narrow strip of land off the north-east of Cephalonia, and lies 20 miles west of the mainland of Greece. The surface is mountainous (2648 feet), and the coast steep and rocky. Area, 37 sq. m. Wine, currants, and olive-oil are largely grown. Goats are kept. Sponges and coral are fished for. The island is celebrated as the principality and home of Ulysses. Pop. 10,650. Chief town, Vathy. See Schliemann's *Ithaka* (1869).

Ithaca, capital of Tompkins county, New York, is picturesquely situated on Cayuga Lake, near the southern extremity, and on the slopes of the neighbouring hills, 35 miles NNE. of Elmira by rail. It has a large trade in coal, and a number of foundries, mills, and factories. Ithaca is the seat of Cornell University (q.v.). Pop. (1890) 11,709.

Itinerary (Lat. *itinerarium*, derived from *iter*, 'a journey'), the name given by the Romans to a written or pictorial account of the principal roads and routes in the empire, with the stations and distances between them. Of the former class the most important are the *Itineraria Antonini* and the *Itinerarium Hierosolymitanum*. The *It. Antonini* are two in number, one containing the routes through the Roman provinces in Europe, Asia, and Africa, and the other the principal sea-routes. They take their name from the Emperor Antoninus Caracalla, under whom they were published, as corrected up to his time, but they seem to have been originally prepared at an earlier date.—The *It. Hierosolymitanum* was drawn up in the 4th century A.D. for the use of pilgrims from Burdigala (Bordeaux) to Jerusalem. Another example of the same class is the *It. Alexandri*, showing the route of march of Alexander the Great through Asia. There is a collected edition of ancient *Itineraria* by D'Urbain (Paris, 1845). For the *Tabula Peutingeriana*, see PEUTINGER.

Iturbide, AGUSTIN DE (1783-1824), emperor of Mexico (q.v.) in 1822-23.

Itzehoe, the oldest town in Holstein, is situated in a valley backed by finely-wooded hills, 40 miles NW. of Hamburg by rail. Principal industries, sugar-refining, cotton-weaving, and the manufacture of machinery, chicory, and soap. Pop. (1890) 12,481. The original castle (Eselsleth), around which Itzehoe or Itzeheo gradually arose, was built by Charlemagne in 809. Itzehoe was twice destroyed by the Swedes during the Thirty Years' War.

Ivan (i.e. John), the name of two grand-dukes and four czars of Russia, three of whom are treated at RUSSIA. The best known, IVAN IV. (1530-84), commonly called Ivan the Terrible, reigned from 1533, and did much for the advancement of his

country in arts and commerce, as well as for its extension by arms. He was the first Russian sovereign to be crowned as czar. He subdued Kazan and Astrakhan, and from his reign dates the first annexation of Siberia. He concluded a commercial treaty with Queen Elizabeth, after the English had discovered (1553) the way to Archangel by sea. But his hand fell with merciless cruelty upon the boyars of his kingdom, and upon some of his towns, as Moscow, Tver, and Novgorod. In the last named some 60,000 people were slain in six weeks. This was, however, during the third period of his reign. The first marks the time during which he was under his mother's guardianship; and the second the era of commercial enterprise and territorial consolidation. Ivan died of sorrow for his son, whom three years before he had slain in a mad fit of rage. See Austin Pember, *Ivan the Terrible* (1895).

Ivanovo, or IVANOFF VOZNESENSK, the 'Manchester' of Russia, in the government of Vladimir, 210 miles by rail N.E. of Moscow. It has been the centre of the Russian cotton industry since the middle of the 18th century. Machinery is also made. Pop. (1897) 35,930.

Ivinghoe, a market-town of Buckinghamshire, 2 miles S.S.E. of Cheddington junction, and 38 N.W. of London. Pop. 1280. Ivinghoe Beacon (904 feet) belongs to the Chiltern Hills.

Iviza (anc. *Ebüssus*), the most south-westerly of the Balearic Isles (q.v.), lies 56 miles from the Spanish mainland. It is mountainous, and its coasts are indented by several bays. Area, 228 sq. m.; pop. 22,800. The principal products are salt and fruits, with a little lead. The chief town, Iviza, which is fortified, is the see of a bishop, and has a population of 7400.

Ivory is the name properly given to the tusks of elephants, a material which consists of that modification of *dentine* or tooth-substance showing in transverse sections lines of different shades running in circular arcs, and forming by their decussation minute lozenge-shaped spaces. By this character, which is presented by every portion of any transverse section of an elephant's tusk, true ivory may be distinguished from every other kind of tooth-substance, and from bone and all artificial imitations of ivory. Although no other teeth except those of the elephant present this characteristic, many other animals, such as the walrus, narwhal, hippopotamus, sperm-whale, &c., possess teeth or tusks which from their large size and from their density can be used for many purposes in the arts for which true ivory is employed. A small proportion of the ivory of European commerce comes from Ceylon, India, Burma, Cochin-China, and the islands of the Eastern Archipelago; but the greater part of the produce of the East is used in the regions of its production. The bulk of the ivory sold in the markets of London, Liverpool, and Antwerp is from the African elephant, and it comes from the interior by nearly every outlet from that continent. A small amount of ivory, brittle in quality, is also obtained from northern Siberia under the name of fossil ivory, being the tusks of the extinct mammoth embedded in the frozen soil of the region. The ivory of the tusks of the African elephant is held in the highest estimation by the manufacturer, on account of its superior density and whiteness. The tusks are of all sizes up to about 180 lb., but examples have been recorded exceeding 200 lb. in weight.

The value of ivory is in proportion to the size and soundness of the tusks. For the purposes of sale they are graded as teeth weighing 60 lb. and upwards, next from 40 to 60 lb., and third between 20 and 40 lb. Below the weight of 20 lb. they are

called *sericellous*, which are classed as hollows and solids. In consequence of its increasing scarcity by reason of the constantly-expanding demand for ivory, there has been a fluctuating but gradual rise in the price of the substance; but in recent years values have remained remarkably steady. Taking west coast African 'teeth' of good quality, the price may be said to have averaged £50 per cwt. during the ten years 1881-90, although according to quality it may range from £37 to £60 in a single sale; while from £50 to £60 may be taken as the price of good ivory in 1890. Selected teeth, and cuts made for special purposes, such as billiard ball solids, may command about £110 per cwt. The quantity annually imported into Europe averages 12,500 cwt., and in the East there is worked up about 2500 cwt. more, to procure which not fewer than 40,000 elephants must be sacrificed. Beyond this there must be many thousands of elephants killed every year in Africa to supply tusks for chiefs and head-men, which they use profusely for the ornamentation of their dwellings and graves. Ivory is conveyed to the coast by slave labour; and it has repeatedly been said that the extinction of the African elephant (which with the present enormous slaughter seems likely ere long to be achieved) would secure the suppression of the slave-trade. Among western communities ivory is chiefly in demand for knife and other handles, combs, piano keys, billiard balls, chess-men, and for carved figures and ornaments. Dieppe is the principal seat of the carved ivory trade; but nearly the half of the material used is worked up in England.

It has been assumed because of the large slabs of ivory used by ancient artists, some of which are still extant, that they possessed a method of softening, bending, and flattening the substance, the secret of which is now lost. One ancient author indeed mentions a means of softening and bending ivory by means of acid solutions, and various recipes are given by medieval writers for that purpose; but these are not found practicable. It is alleged that immersion in a solution of phosphoric acid renders ivory pliant and translucent; but that is done at the expense of its texture and elasticity—in short, such treatment deprives the substance of the very qualities which render it valuable.

The use of ivory can be traced almost to the earliest period at which there is evidence of the existence of man upon the earth. On fragments of mammoth tusks which have been picked up in the caves of Dordogne there have been found incised drawings of many animals, some now extinct and others no longer inhabiting Europe, executed with a spirit and fidelity which are simply marvellous. From that time downwards the records of every civilised community demonstrate the important place occupied by ivory, and the high commercial value it possessed. It was a substance distinctive of royal state and authority in ancient monarchies; and we read that King Solomon 'made a great throne of ivory.' There still exist examples of Egyptian inlaid ivory as ancient as the days of Moses, and Mr. Layard in his Nineveh excavations secured many Assyrian ivory carvings, believed to date nearly 1000 B.C., which are now preserved in the British Museum. When culture and art were at their height in ancient Greece ivory was lavishly used for carvings, sculpture, and objects of luxury; and many of the greatest and most famous works of Phidias and his fellow-artists were 'Chryselephantine' (q.v.) statues—gigantic works built of plates of ivory and gold, some of the figures reaching a stature of 40 feet. Among the Romans the use of ivory for purposes of luxury was equally extensive; and by them plates of ivory, joined as diptychs or

triptychs, were used as writing-tablets. Presents of such diptychs were commonly made by consuls on their appointment to officials within their jurisdiction, and among the treasures of classical times which yet exist are many remains of consular ivories. In the middle ages ivory came into use for ecclesiastical purposes in the form of tablets and diptychs for keeping registers and records, for crucifixes, statuettes of saints, caskets, reliquaries, croziers, book covers, &c. At the same period for secular use it was carved into chess-men, mirror cases, combs, 'oliphants' (hunting and tenure horns), and numerous other forms.

Ivory, VEGETABLE. This curious material is furnished by the palm-like plant, *Phytolaphis macrocarpa*, which grows on the Andean plains of Peru, and on the banks of the river Magdalena, and other parts of South America. It forms the type of a natural order, the Phytelphasiae, intermediate between the Palms and the Screw Pines (Pandaneae). The plant throws up a magnificent tuft of light-green pinnated leaves of extraordinary size and beauty, like immense ostrich-feathers, rising from 30 to 40 feet in height. The fruit, which is as large as a man's head, consists of many 4-celled leathery drupes aggregated together, and contains numerous nuts of a somewhat triangular form, each nut being nearly as large as a hen's egg; they are called *Corozo nuts* in commerce. The kernels of these nuts when ripe are exceedingly hard and white, in fact they resemble ivory so completely that few names have ever been better applied than that of vegetable ivory. They are in extensive use by turners in the manufacture of buttons, umbrella-handles, and small trinkets. Two or three millions of these nuts are now imported into Britain annually, and are chiefly used by the London and Birmingham turners.—For another ivory substitute, see CELLULOID.

Ivory-black. See CHARCOAL.

Ivory Coast, a part of the northern coast of the Gulf of Guinea, West Africa, embraces the districts between Cape Palmas and the river Assini. Its western portion belongs to Liberia; its eastern, now counted as part of the Gold Coast, is shared between Britain and France. The name bears no political meaning.

Ivrea, a town of Piedmont, on an eminence at the southern end of the Val d'Aosta, 38 miles NNE. of Turin by rail. Founded in accordance with an injunction contained in the Sibylline Books about 100 B.C., it has a cathedral which is supposed to occupy the site of a temple to Apollo. It was the seat of a Lombard duchy, and under the Carolingians of a marquise. One of the marquises of Ivrea, Berengar II., became titular king of Italy (q.v.) in the 10th century, and his grandson founded the line of the dukes of Burgundy. Incorporated with the empire in 1018, the town and marquise were given by Frederick II., in 1248, to the House of Savoy. Pop. 5883.

Ivry, a village of over 1000 inhabitants in the French department of Eure, 16 miles NNW. of Dreux. On the Plain of Ivry was fought, 14th March 1590, the famous battle between Henry of Navarre and the armies of the League. **IVRY-SUR SEINE,** a south-eastern suburb of Paris, on the Seine. Glass, earthenware, and chemical products are the chief manufactures. Pop. (1881) 18,442; (1891) 22,357.

Ivy (*Hedera*), a genus of plants of the natural order Araliaceae, consisting of shrubs and trees, mostly natives of tropical countries. The flowers have five or ten petals, and five or ten converging or consolidated styles. The fruit is a berry with

five or ten cells.—The Common Ivy (*H. helix*) is a well-known native of Britain, and of most parts of Europe, although it is more rare in the northern countries. Its long, creeping, branched stem, climbing on trees and walls to a great height, and closely adhering even to very hard substances by means of aerial rootlets, which it throws out in great abundance along its whole length, acquires in very aged plants almost the thickness of a small tree. Its 5-lobed, shining, stalked, evergreen leaves, clothing bare walls with green luxuriance, serve to throw off rain, and thus render damp walls dry, contrary to a common prejudice, that ivy tends to produce dampness in walls. In order to accomplish this, however, it requires to be pruned annually, for if allowed to run wild it admits rain to the walls by its projecting branches, and so renders even dry walls damp by preventing evaporation. It injures living trees by constriction when permitted to grow upon them. The flowering branches of ivy have ovate, entire leaves, very different from the others, and do not climb, but project from the climbing branches. Its small greenish flowers are produced in the beginning of winter, and the small black berries swell during winter and ripen in the following April. The berries are eagerly eaten by many birds, although they have a pungent taste, and contain a peculiar bitter principle called *hederine*,



Ivy, showing the aerial Rootlets.

and an acid called *hederic acid*; which are also found in a gummy exudation obtained by incisions from the stem, and occasionally used in medicine as a depuratory and a stimulant, and in varnish-making. An ointment made from the leaves is used for curing burns; the application of bruised leaves is serviceable for removing corns. In Egypt the ivy was sacred to Osiris, in Greece to Bacchus (Dionysos), whose thyrsus was represented as surmounted with ivy; the Romans mingled it in the laurel crowns of their poets.

There are numerous varieties of common ivy often planted for ornamental purposes, of which that generally known in Britain as *Irish Ivy*, and on the Continent as *English Ivy*, is particularly esteemed for its large leaves and luxuriant growth. They are distinguished from each other by the form of their leaves, and also by their colour, there being many shades of green and bronze, and not a few with gold and silver blotched leaves. Ivy grows readily from cuttings. *H. umbellifera*, a native of Amboyna, is said to produce a finely aromatic wood; and *H. terebinthacea*, a Ceylonese species, yields a resinous substance which smells like turpentine.

Ixion, a king of the Lapithae, the father of Phithons. Unable to find purification on earth for the treacherous murder of his father-in-law, he was taken up into heaven and purified by Zeus. But he attempted to seduce Hera, and for punishment he was chained to a fiery wheel, which rolled for ever in the sky.

Izard, the Pyrenean Hex. See GOAT.

J



is the latest addition to our alphabet, and has been inserted, as the tenth letter, after *i*, from which it was developed, just as *c* and *v* follow *u*, out of which they arose. In the 14th century it became the fashion, in Provençal and Catalan MSS., to lengthen the letter *i* into the form *j*, with a tail turned to the left, as a sort of ornamental initial at the beginning of words. The consonantal sound usually occurring at the beginning, and the vowel-sound in the middle or at the end of words, the initial form *j* after a while became conveniently but undesignedly specialised to denote the consonantal sound, the medial form *i* being retained for the vowel-sound. In the 15th century this usage, which never reached Italy, spread to France and England, but it was not before the middle of the 17th century that it became universal in English books, as is shown by the fact that in King James's Bible of 1611 the words *Jesus* and *judge* are printed *Iesus* and *iudge*.

The dot over the *j* is a curious survival. It is unnecessary as a diacritical mark, which it originally was (see I), as there is no danger, in its present form, of confusion with any other letters. The dot remains as a witness not only that *j* was developed out of *i*, but also of the fact that the evolution of *j* was later than the practice of dotting the *i*.

In English the symbol *j* is used to denote the sound of *dzh*, as in *journal*; in French of *zh*, as in *jour*; in Spanish it represents the hard *ch*, heard in the Scotch *loch*, as in *Jerez*; in German it retains the original *y* sound of the Latin consonantal *i*, as in *Jahor*. Thus, while German geographers write *Jeinissei* and *Jakut*, English maps have *Yenissei* and *Yakut*.

The consonantal sound of the English *j* is frequently expressed by *y*, as in *you* or *gin*, or by *g*, as in *knowledge*. The sound did not exist in Early English, but was introduced from France after the Norman Conquest. Hence in Middle English, before the symbol was invented, we find the sound represented by other devices. Thus, we have *Gires* for *Jews*, *goste* for *jest*, *cheur* for *jeur*, and *chaun* for *jeun*. Chaucer has *gylter* where the Bible has *judor*. The use of *j* is still extending, and we find *jibe*, *jail*, and *Jeffrey* occasionally used, instead of the more correct forms *gibe*, *gaid*, and *Geoffrey*.

We have unfortunately introduced our required French sound of *j* into Latin words which had the consonantal *i*, which the Romans pronounced as *y*; and we say *jan*, *jugum*, *janens*, *Jupiter*, *janens*, *janis*, *janus*, and *major*, where the Romans said *jan*, *yugum*, *yauens*, *Yupiter*, *yauens*, *yikou*, *hupus*, and *mayor*. In some inscriptions of the early imperial age the consonantal sound of *i* is denoted either by doubling the letter or writing it as a capital; 'huius,' or 'hulus,' representing the older spelling *huius*. In inscriptions of the later empire we find *Giree* for *Jove*, a usage adopted in modern Italian, in which we have *Gesù*, *Giovanni*, *Giuseppe*, and *maggiore*, from *Jesus*, *Johannes*, *Josephus*, and *major*, the use of the new letter

j being evaded in the same manner as in Middle English.

Jabalpur (*Jubbulpore*), chief town of Jabalpur district, Central Provinces, India, 228 miles by rail SW. of Allahabad. Standing at the junction of the East Indian and Great Indian Peninsula systems, Jabalpur is one of the most important railway stations in India. It is the second commercial town in the Central Provinces, has a trade worth about £2,000,000 annually, and manufactures cotton, tents, and carpets. Pop. (1877) 55,188; (1891) 84,481.—The *district* of Jabalpur has an area of 3948 sq. m., and a population of 748,146.—The *division*, one of the four into which the Central Provinces are broken up, has an area of 18,321 sq. m., and a pop. of 2,375,642, of whom three-fourths are Hindus.

Jabiru (*Mycteria*), a genus of birds of the Stork family (Ciconiidae); the chief distinction from the storks being that the bill is a little curved upwards. There are four species, which are found in Africa, India, Australia, and South America. The best known is the American Jabiru (*M. americana*), which is found from Mexico southwards to the Argentine Republic. It is a large bird, measuring from 4 to 5 feet in height, with white plumage, except on the head and neck, and a massive bill. The Jabirus of India and Australia are sometimes elevated to the rank of separate genera.

Jaborandi. Under this name a number of drugs, used for their sialagogue and diaphoretic actions, are known in Brazil. In Europe, however, only the leaflets of *Pilocarpus pennatifolius* are recognised as jaborandi. It is a shrub about 4 or 5 feet high, slightly branched, the branches erect, leaves alternate, long-stalked, imparipinnate, and 1 to 1½ feet long; leaflets opposite, in two up to five pairs, with a terminal leaflet. Each leaflet is about 4 inches long, oval-oblong, very obtuse or emarginate at apex, entire, coriaceous, and containing a number of glands which show as dots against the light. Flowers in racemes. This species is a native of Brazil. Jaborandi is official in the British Pharmacopœia, and is there defined as the dried leaflets of *Pilocarpus pennatifolius*. They contain an alkaloid, pilocarpine, C₁₁H₁₆N₂O₂, to which the effects of the plant are chiefly due; another alkaloid, jaborine; and two decomposition products of these, named respectively pilocarpidine and jaboridine. There are also present a volatile oil and a bitter substance. Jaborandi was first brought to the notice of medical men in Europe by Dr Coutinho of Brazil in 1871, and since then its action has been very fully investigated by numerous physiologists. When pilocarpine, or preparations taken from it, are taken internally there ensue very profuse salivation and perspiration, with depression of the circulation and disturbance of vision. Large doses cause in addition nausea, vomiting, and great muscular relaxation. The salivation and perspiration may be completely arrested or prevented by the administration of atropine. Locally applied to the eye it causes contraction of the pupil, and interferes with accommodation and vision. It is used in iritis, in Bright's disease,

and in various conditions where its sialagogue or diaphoretic effects are desirable.

Jacamars, a small family of brilliantly coloured birds (Galbulidae), inhabiting dense forests in tropical America east of the Andes. They are apparently dull and stupid, like their near relatives the Puff-birds (Bucconidae). The bill is long and usually straight, the feet are short and feeble, the front toes are united for some distance, the plumage exhibits a rich metallic splendour. They feed on insects. The white eggs (two) are laid in holes excavated in sandy banks. Technically this family, including about a score of species, is ranked among the Picariae, subdivision Picoideae, beside the puff-birds, and at a greater distance toucans and wood-peckers. The type is *Galbula gallinula*, resplendent in golden green; *Jacuncopsis grandis* is the largest species; the members of the genus *Urogallica* shine like black steel.

Jacana (*Paridae*), a family of birds allied to the Rails (Rallidae), but differing from them and from all other birds in possessing extremely long, slender, straight toes with long, sharp, pointed claws. They have pointed spurs on their wings, and many have a shield on the forehead like coots and moor-hens. They are found in all the tropics, and are birds of elegant plumage, frequenting swamps, lagoons, and marshes, where they walk on the broad floating leaves of aquatic plants with the greatest ease. The genus *Parra* (ten species) is

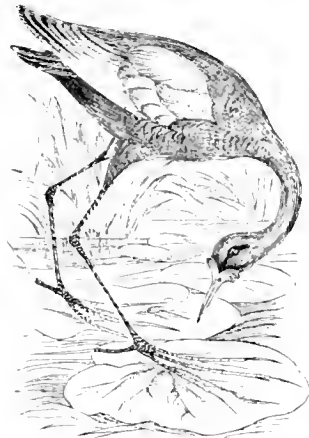

Common Jacana (*Parra jacana*).

widely distributed in the warm parts of South America, Africa, Asia, and also the Australian region. The Common Jacana (*Parra jacana*), a South American species abundant in Guiana and Brazil, is about 10 inches long, of a black colour, with neck and shoulders of a reddish-brown tint, and with green wing-feathers. The other genus (*Hydrophasianus*) of the family consists of only one species, the Pheasant-tailed Jacana, which is confined to the oriental region. It is the largest of all the Jacanas, and is found in India and Ceylon, where it inhabits marshes and reedy banks, feeding chiefly on vegetable matter, but also on shells and water insects. The flesh forms excellent eating.

Jacaranda Wood, a very hard, heavy, brown wood, also called *Rosewood*—though not the true Rosewood of commerce—from its faint, agreeable smell of roses. It is brought from South America, and is produced by several trees of the genus *Jacaranda*, of the natural order Bignoniaceae. Several species of this genus are called Caroba in Brazil, and are there accounted anti-syphilitic.—Several species of the nearly-allied genus *Tecoma* also have an extremely hard wood, as *T. pentaphylla*, a native of the Caribbean Islands. The Brazilian Indians make their bows of the wood of *T. toxicaria* or *Pao d'arco*.

Jacare. See ALLIGATOR.

Jacinth, or HYACINTH (Ital. *giacinto*, Lat. *hyacinthus*), a transparent, bright coloured variety

of Zircon (q.v.), of various shades of red, passing into orange and poppy-red. A perfect stone has a peculiar golden lustre mixed with its rich orange, and would formerly have fetched a high price; but the jacinth is no longer in fashion. By the ancients it was highly prized, and many fine intagli were executed in it, notwithstanding its hardness, which exceeds that of chalcidony and its varieties. Antique intagli in jacinth, however, almost invariably exhibit a somewhat rubbed or worn surface, which is believed to be due to the somewhat porous texture of the gem. Jacinth occurs in many basalts, tuffs, and some granitoid plutonic rocks, as, for example, near Expailly in Auvergne, and at Unkel on the Rhine, in Bohemia, Saxony, the Tyrol, Norway, the Urals, Greenland, &c. It is likewise met with in the form of granules and rounded crystals in the beds of certain streams, and in alluvial deposits, as near Expailly, in the Isere, and in certain streams in Ceylon. The jacinth or hyacinth of jewellers is not a zircon at all, but some variety of garnet—generally Cinnamon-stone (q.v.); and sometimes ferruginous quartz, which, from its abundance in gypsum at Compostella, in Spain, is called *Hyacinth of Compostella*.—*Jargoon* is the name given by the Singalese to another variety of zircon. It is usually gray or colourless, but often shows more or less ill-defined tinges of green, blue, red, and yellow. The surfaces of the crystals have a lustre almost rivaling that of the diamond. It was at one time supposed to be an inferior variety of the diamond, and is still occasionally sold as such.

Jack has been from the beginning generally used in England as the equivalent of John, the most common of Christian names, but it is not a little curious that it is really the French *Jacques* (till the 17th century pronounced as a dissyllable), and so through the Latin *Jacobus* and Greek *Jakobos* from the Hebrew *Ya'acob*, Jacob. Others, however, explain it as a shortened form of *Jankin*, an old diminutive of *Johann*, *Jehan*, or *John*; from the northern forms of which again, *Johakin* or *Jankin*, we have *Jockey* and *Jack*. The contempt that follows on excessive familiarity attaches itself in most European languages to the name John and its equivalents; thus we find the Italian *Gloria*, whence *Zanni*, our *Zany*; the Spanish *Juan*, as *bobo Juan*, 'a foolish John'; the French *Jean*, with its signification in compound terms of fool, cuckold, and the like; and our own vulgarisms, 'every man *Jack*' for all men without distinction, a '*Jack*-of-all-trades,' and a '*Johanny*' for a man of no particular account. Again, such compounds as '*Jack*-fool,' '*jack*-ass,' a '*jack*-pudding,' '*jack*-an-apes' (with intrusion of *n* for *Jack*-o'-apes) point in the same direction. From the sense of familiarity it came to be used of various implements which served instead of a boy or personal attendant, as in '*boot*-*jack*' and the kitchen '*jack*' which turns the spit. Somewhat similar are such usages as drinking *jack*, the '*jack*' for the small bowl aimed at in a game of bowls, and for the *knaves* in a pack of cards, as well as for a small pike as opposed to the full grown fish. Again, in complete harmony with the sense are such compounds as '*Jack*-a-lantern' and '*Jack*-a-lent' (Shakespeare, *Merry Wives*, III. iii. 27). *Jack* the Giant-killer and *Jack* and the Bean-stalk again show the same sense of familiarity without the accompanying contempt.

Jack, or JACA (*Artocarpus integrifolia*), a tree of the same genus with the Bread-fruit (q.v.), a native of the East Indies. It is a larger tree than the bread-fruit, and has larger fruit.

Jackal (Persian *shaykal*, Fr. *chaval*), the name of a number of species of the genus *Canis*

(see Dog), which are in many respects intermediate between the wolves and foxes. *Canis aureus*, being the most typical and widespread form, sometimes goes under the name of the Common Jackal. It



Common Jackal (*Canis aureus*).

measures about 3 feet in length, one-third of which is occupied by the tail, whilst the height is about 18 inches. The animal's build is strong, the muzzle is more acute than that of the wolf, blunter than that of the fox, and the bushy tail hangs down as far as the heel. The ears are short, less than one-fourth the length of the head, and far apart; the pupil of the eye is round. The colour is difficult to define: its ground-tint is a dirty fawn or grayish-yellow, becoming blacker on the back and sides; the under surface is white, reddish-yellow, or gray, and there are not unfrequently ill-defined dark bands on the shoulders and hind-quarters. The home of this species is the southern part of Asia, from India (including Ceylon) over Persia, Arabia, Palestine, and Asia Minor. Hence it has spread, perhaps following the track of armies, to North Africa, the Morea, and Dalmatia. In its habits as well as in its structure it exhibits characters intermediate between the wolves and foxes; like the former it hunts in packs, like the latter it is nocturnal. When on the chase these animals howl most dismally, and make the night hideous in regions where they abound. The singularly appropriate Arabic name *Deeb* ('howler') has reference to this habit. So far from avoiding the proximity of man, they penetrate into villages in search of offal and carrion, and they will also enter yards, houses, or tents in the most shameless manner, and carry off whatever takes their fancy, sometimes articles absolutely uneatable. They render a certain amount of service as scavengers and by killing vermin, such as mice, but this is by no means an equivalent for the damage they cause by their depredations in sheepfolds and poultry-yards, as well as orchards and vineyards. In many districts they constitute a veritable scourge, and can only be held in check by their congeners the dogs. They follow the larger carnivores to feed upon their leavings, a habit which has given them the reputation of being 'the lion's providers.' They are extremely cunning, and in oriental fable and proverb take the place of our reynard in this respect. The word 'fox' in the Old Testament probably refers in many cases to them. According to Sir Emerson Tennent, they habitually hide their booty, and if observed will seize some indifferent article and make off with it, as though that were the object of their solicitude, returning to their real spoil at the first convenient opportunity. The skull of certain jackals has a horny outgrowth some half-inch in length, eagerly sought for as a charm. Jackals are readily tamed, and the likelihood that they have given rise to some of the domestic dogs has already been alluded to (see Dog). The

Striped Jackal (*Canis lateralis*, *C. adustus*) is a connecting link between the wolf and jackal. The extreme length is a little over a yard, and the height rather less than half this; the pupil of the eye is somewhat elliptical and oblique, the ears widely separated. The species is rather rare, but has a wide distribution in Africa south of the Sahara. The Jackal-wolf (*Canis anthus*) is even more wolf-like than the last, and has been classed by different authors among the wolves or jackals. It is much smaller than the wolf, and inhabits Northern Africa. The Black-backed Jackal (*Canis mesomelas*) is somewhat more fox-like than the others, especially in the form of the head. The general build is low. The ears are large and close together, recalling those of the Fenec (see Fox). The area of distribution of this species extends from Middle Nubia down the east side of the continent to the Cape, and perhaps across to the west coast also.

Jack-a-lantern. See IGNIS FATUUS.

Jackass, LAUGHING. See LAUGHING JACKASS.

Jack-boots. See BOOTS AND SHOES.

Jackdaw (*Corvus monedula*), a species of crow, smaller than the rook and carrion crow, its utmost length being only about fourteen inches. It is black, with purplish wings and tail, and a dark-gray neck. It is a common resident in the British Islands, and is found nearly all over Europe, in many parts of which, however, it appears to be migratory; also in Asia and the north of Africa. It is not found in America. Its food consists of insects, snails, and worms. It builds its nest in holes of cliffs, ruins, and old trees. It frequents towns and villages, often making its nest in a chimney, by dropping down stick after stick till some of them become fixed in their oblique descent; and on these others are piled, affording a firm base for a nest of wool or other soft substance. The jackdaw lays from four to seven (usually five) bluish-white eggs, which are covered with small dark-brown spots. The jackdaw is a social bird. It is easily domesticated, and becomes very pert and familiar. It has considerable powers of mimicry, and may be taught to imitate very exactly the human voice.

Jackson, (1) a flourishing city of Michigan, capital of Jackson county, is on both sides of Grand River, which is here crossed by seventeen bridges (five of iron), 76 miles W. of Detroit, and 37 miles S. of Lansing, at the intersection of several railways. It has a number of flour, paper, and planing mills, and of foundries and machine-shops; the Michigan Central locomotive-works; breweries; and manufactures of furniture, carriages, wagons, boilers and machinery, farming implements, corsets, soap, &c., besides boots and shoes at the state-prison here. There is a flourishing general trade. Within the city limits, and close by, there are several mines of bituminous coal. Jackson was settled in 1830, and became a city in 1857. Pop. (1860) 4799; (1870) 11,447; (1890) 20,798. —(2) Capital of the state of Mississippi, on Pearl River, 45 miles E. of Vicksburg by rail, with regular streets, and houses standing for the most part among gardens. Here, besides the state-house, with a valuable library, are the usual state charitable institutions, and the penitentiary. There is a considerable trade in cotton. Pop. 5920. —(3) Capital of Madison county, Tennessee, on the South Fork of the Forked Deer River, 107 miles by rail S. by E. of Cairo, Illinois. It is the seat of the South western Baptist University (1874), is of some importance as a cotton market, and has planing and other mills and railway shops. Pop. (1890) 10,039.

Jackson, Andrew, General, seventh president of the United States, was born at Waxhaw on the southern border of North Carolina, March 15, 1767. His father, an immigrant from the north of Ireland, died a few days before Andrew's birth, and his mother and brother succumbed to the hardships of the revolutionary war. After being admitted to the bar at Salisbury, North Carolina, Andrew removed in 1788 to Nashville, then a frontier settlement, and was appointed public prosecutor. In 1791 he married Mrs Rachel Roberts, daughter of Colonel John Donelson, supposing that she had been divorced from her former husband. But the divorce not being legally granted until 1793, Jackson had the marriage ceremony repeated. These circumstances furnished material for malignant attacks, and the irritable Jackson fought several duels, in one of which, after he had a rib broken, he killed his antagonist. In the new state of Tennessee Jackson was a leading man; after helping to frame its constitution, he became its representative in congress in 1796, its United States senator in 1797, and a judge of its supreme court in 1798. This position he held until 1804, when he resigned. He gave some support to Aaron Burr's half-revealed schemes of conquest in the south-west, and when Burr was tried at Richmond in 1807 was still his steadfast partisan.

When war was declared against Great Britain in 1812, Jackson, being major-general of the state militia, offered his services and led 2500 men to Natchez, but General Armstrong, the new secretary of war, ordered him to disband them. Jackson, however, marched them in a body back to Nashville, where soon afterwards, in an affray with Colonel T. H. Benton, he was severely wounded. With his fractured arm still in a sling, the general took the field in September 1813 against the Creek Indians in Alabama. This campaign, in which his military genius was first effectively displayed, was closed by a decisive victory at the Horseshoe Bend of the Tallapoosa River, March 27, 1814. Henceforth he was familiarly called 'Old Hickory.' On May 31 he was made major-general in the regular army, and appointed to command the department of the South. Pensacola in Spanish Florida being then freely used by the British as a base of operations, Jackson took the responsibility of invading Spanish soil, stormed Pensacola, and when the British fleet withdrew marched to New Orleans, which was threatened by Sir E. Pakenham with 12,000 veterans. Jackson made his chief defence 4 miles below the city, where, along a ditch extending from a swamp to the Mississippi, he constructed earthworks. On January 8, 1815, under cover of a fog, Pakenham tried to carry these works by direct assault, but within half an hour the British were repulsed with a loss of 2600 men, including their commander, while the American loss was but 8 killed and 13 wounded. This battle was remarkable not only for the unprecedented disparity of loss, but for the fact that it was fought after the treaty of peace had been signed at Ghent, December 24, 1814.

In 1818 Jackson again invaded Florida, severely chastised the Seminoles, and executed Arbuthnot and Ambrister, convicted by court-martial, on very slight evidence, of inciting the Indians to war. After the purchase of Florida Jackson was its first governor, but soon resigned, and in 1823 he was again elected to the United States senate. In the next year as a candidate for the presidency he had the highest popular vote, but not a majority. The choice was, therefore, made by the House of Representatives from the three highest candidates, and J. Q. Adams was selected; but when he appointed Henry Clay secretary of

state, Jackson and his friends alleged that a bargain had been made, transferring Clay's votes to Adams. In 1828 Jackson was elected, having 178 electoral votes out of a total of 261. The first president from beyond the Alleghanies, he was a typical product of the new democratic era—fearless, honest, but prompt to decide everything for personal reasons. A striking feature of his policy was the sweeping removal of minor officials and filling their places with his partisans. This system was aptly described by Senator W. L. Marcy in 1831: 'To the victor belong the spoils.' Jackson's first cabinet was broken up in consequence of his characteristic but futile effort to compel social recognition of Secretary Eaton's wife by the families of the other secretaries. The second cabinet was in the main composed of abler men. Martin van Buren, who had been secretary of state, was nominated minister to England, but after he had gone abroad his confirmation was defeated in the senate by the casting vote of Vice-president Calhoun. This strenuous advocate of state sovereignty was now openly opposed to Jackson, as was shown at a banquet in 1830, when the president gave his famous toast—'The Federal Union—it must be preserved,' and the vice-president responded with another—'Liberty—dearer than the Union.' Congress readjusted the tariff in 1832, retaining the protective system which had prevailed since the peace of 1815, and against which South Carolina had protested as unconstitutional and oppressive. On November 24, 1832, its state convention adopted an ordinance of nullification. President Jackson's proclamation, prepared by Edward Livingston, who had succeeded Van Buren as secretary of state, ably argued the whole question, and declared a firm determination to execute the laws and preserve the Union. Under the leadership of Clay, congress adopted a compromise tariff in March 1833, and South Carolina repealed its ordinance.

The president's veto power was much more freely used by Jackson than by his predecessors. His most memorable veto was that of a bill to renew the charter of the United States Bank, which became the chief issue in the presidential campaign of 1832. Jackson, having obtained 219 electoral votes out of 286, resolved to destroy the bank by removing the government deposits. Two successive secretaries of the treasury refused to do so, but a third who was not confirmed by the senate issued the order. The senate censured this act as usurpation, but Jackson had a closing triumph when the censure was expunged on January 16, 1837. In his administration the national debt was fully paid in 1835, and the surplus revenue which accumulated was ordered to be distributed to the several states. In foreign affairs Jackson won credit by enforcing the claims for the spoiliations committed by French vessels during the wars of Napoleon. In 1831 France by treaty agreed to pay \$5,000,000, but afterwards delayed payment. The president then recommended to congress to seize French vessels to make up the amount, and France after a protest paid the claim. Jackson's second term having expired on March 4, 1837, he retired to private life at the Hermitage, near Nashville, whence he still watched with keen interest the great political movements of the time. He died at the Hermitage, June 8, 1845.

The most complete biography is by James Parton (3 vols. New York, 1860). For Jackson's administration, T. H. Benton's *Thirty Years' View*, and Von Holst's and other histories of the United States should be examined. See also the Life by W. G. Sumner, in the 'American Statesmen' (1882), and that by Dyer (1891).

Jackson, Thomas Jonathan, an American general, better known as 'Stonewall Jackson,' was

born at Clarksburg, West Virginia, 21st January 1824, graduated at West Point in 1846, entered the artillery, and gained two brevets in the war with Mexico. He retired from the army in 1851, and became professor in the Virginia Military Institute, where he was more noted for his conscientiousness and religious earnestness than for his success as a teacher. He took command of the Confederate troops at Harper's Ferry on the secession of Virginia, and commanded a brigade at Bull Run, where his firm stand gained him his *nom de guerre* of 'Stonewall.' Promoted to major-general, in the spring of 1862, in the campaign of the Shenandoah valley, he out-generalled McDowell, Banks, and Fremont, and eventually drove back upon the Lower Shenandoah these three Federal armies, two of them of superior strength to his own. Then, hastening by forced marches to Richmond, he turned the scale at Gaines's Mills (27th June), and, the Confederate capital relieved, returned to defeat Banks at Cedar Run in August. He then seized Pope's depot at Manassas, and his corps bore the brunt of the fighting in the victorious second battle there on 30th August. On 15th September he captured Harper's Ferry with 13,000 prisoners and 70 cannon, and the next day, after a trying night march, arrived at Sharpsburg, where his presence, in the battle of Antietam, saved Lee from utter disaster. Advanced to lieutenant-general, he commanded the right wing at Fredericksburg (13th December), and at Chancellorsville on 1st May 1863 drove Hooker back within the Wilderness. All next day Jackson was on the march, moving round the flank of the National army; at nightfall he fell upon its right and drove it back on Chancellorsville. Returning from a reconnaissance, his party was fired on by some of his own command, and Jackson received three wounds. His left arm was amputated; but pneumonia set in on the 7th, and on the 10th May he died. Jackson was the idol of his troops; and his power over his men was justified as much by his soundness of judgment as by his personal fearlessness. No single death was so severe a blow to either side. See Lives by Dabney (1866), Cooke (1866), his wife (1892), Parton (1893), and G. F. Henderson (1898).

Jackson, WILLIAM (1730-1803), musician, was born at Exeter, where, after some years in London, he in 1777 became organist of the cathedral. He published many songs and canzonets, besides sonatas, dramatic pieces, &c., some of his compositions having great vogue in their day.

Jacksonville, (1) capital of Duval county, Florida, and the principal business town in the state, is on the St. John's River, 23 miles from its mouth. The meeting place of five railways, it is 165 miles by rail E. of the state capital, Tallahassee. The streets are wide and well shaded; there are numerous hotels, chiefly for the accommodation of invalids and winter visitors. The city has a large coast trade, besides an active river trade. The chief exports are lumber, cotton, moss, oranges and marmalade, and early vegetables. Pop. (1880) 7659; (1890) 17,291—more than doubled.—(2) Capital of Morgan county, Illinois, stands in a fertile prairie region, at the junction of several railways, 34 miles W. by S. of Springfield. It is a pleasant town, and noted for its schools. Here are the Illinois College (Congregational; founded 1830), the Illinois Female College (Methodist; founded 1847), a conservatory of music, and other educational institutions; and here, too, are state asylums for the blind, the deaf and dumb, and the insane, and an asylum for the idiotic and feeble-minded. There are manufactures of woollens, paper, machinery, boilers, lumber, furniture, confectionery, &c. Pop. (1880) 10,927; (1890) 12,935.

Jacob (Heb. *Ya'aqob*), one of the three chief Hebrew patriarchs, second son of Isaac and Rebekah, whose history and character are graphically described in the Book of Genesis. He and his family followed Joseph to Egypt, where he lived for seventeen years; and, dying there, he was carried to Hebron for burial. Many see in the history of Jacob (on whom Israel, the name of the nation, was also conferred) an ethnological record rather than a personal one. Mention is frequently made of Jacob both in the Old and New Testaments, and there are also many legends about him in Rabbinical and Patristic, as well as in the Mohammedan literature. The names *James*, *Jacques*, *Giuseppe* are all, as well as *Jacob* and *Yakob*, various modern derivatives from the Hebrew patriarch's name. See JEWS.

Jacob, BILLOPHILE. See LACROIX, PAUL.

Jacobabad, a town of Upper Sind, 26 miles NW. of Shikarpur by rail, near the Beluchi frontier, has cantonments, a residency, and accommodation for the trade caravans from central Asia. Here is the memorial tomb of General John Jacob, commandant of the Sind Horse, who founded the place in 1847, and died here in 1858. Pop. 11,352, including cantonments.

Jacobi, FRIEDRICH HEINRICH, a German philosopher, born at Düsseldorf, 25th January 1743. The son of a merchant, he was trained at Frankfurt and Geneva for a mercantile career. But, abandoning business, he was in 1770 appointed councillor of finance for the joint duchies of Jülich and Berg, and thenceforward devoted himself principally to literary and philosophical pursuits. He maintained an active correspondence with Goethe, Hamann, Bonterwek, and was acquainted with Wieland, Herder, Lessing, Hemsterhuis, and others. In 1804 he was summoned to Munich in connection with the newly-founded Academy of Sciences, of which he became president in 1807. He died at Munich, 10th March 1819. Jacobi was not a systematic thinker; he elaborated no system of philosophy. He had become convinced of the truth of one or two leading ideas; and from the standpoint they gave him he examined the chief modern philosophies that were known in his day. His distinguishing doctrines are these: philosophy as elaborated by the understanding cannot transcend the sphere of sense-given materials, and consequently can never get conviction of the existence of such things as God, immortality, &c.; but man has yet another faculty whereby he has immediate conviction of the real existence of things—viz. reason; by this faculty we have immediate conviction or belief not only of the reality of objects perceived by the senses, but also of the reality of the highest verities that lie beyond the apprehension of sense. Taking these views for his guidance he successively examined Spinozism, in *Ueber die Lehre des Spinoza*, in *Briefen an Mendelssohn* (1785); Hume's teachings and Kant's, in *David Hume über den Glauben, oder Idealismus und Realismus* (1787); and Schelling's philosophy, in *Von den göttlichen Dingen und ihrer Offenbarung* (1811). He also expounded his teaching in philosophical romances—*Waldemar* (1779) and *Ulbricht's Briefsammlung* (1781)—in an *Open Letter to Fichte* (1799), and other occasional writings. His works appeared at Leipzig in 6 vols. in 1812-24. See monographs on him by Kuhn (1834) and Zirngiebl (1867).

Jacobi, KARL GUSTAV JAKOB, German mathematician, was born at Potsdam, 10th December 1804. He studied at the university of Berlin, and in 1827 was appointed extra ordinary, and two years later ordinary professor of Mathematics at Königsberg. Jacobi excelled in analytical mathematics;

his name is best known from his discovery of elliptic functions. Besides this he did most valuable work in connection with differential equations and the theory of numbers: his name is perpetuated in the theory of determinants. In 1829 he published his most celebrated work, *Fundamenta nova Theoriae Functionum Ellipticarum*, for which he received the medal of the Academy of Sciences of Paris. Most of his other investigations were published in *Crelle's Journal für Mathematik*. Jacobi was acquainted with Gauss, Legendre, Abel, and other great mathematicians of his own day. In 1842 he retired from his chair, owing to ill-health, and settled at Berlin. He died in that city on 18th February 1851. His *Gesammelte Werke* (7 vols.) were published by the Berlin Academy in 1881-91.

Jacobins, the members of a political club which exercised a very great influence during the French Revolution. It was originally called the *Club Breton*, and was formed at Versailles, when the States-general assembled there in 1789. It then consisted exclusively of members of the States-general, all more or less liberal or revolutionary, but of very different shades of opinion. On the removal of the court and National Assembly to Paris this club began to acquire importance. It now met in a hall of the former Jacobin convent in the Rue St Honoré, Paris: the Dominicans of France having come to be known as Jacobins from their chief Paris establishment being that of St Jacques (*Jacobus*) in the Rue St Jacques. Hence the revolutionary association received the name of the Jacobin Club, which was first given to it by its enemies; the name which it adopted being that of the *Society of Friends of the Constitution*. It now also admitted members who were not members of the National Assembly, and held regular and public sittings. It exercised a great influence over the agitation, of which the chief seat and focus was in the capital, and this influence was extended over the whole country by affiliated societies. Its power increased, until it became greater than that of the National Assembly. It formed branch societies or clubs throughout France, of which there were soon not less than 1200. When the National Assembly dissolved itself in September 1791, the election of the Legislative Assembly was mainly accomplished under the influence of the Jacobin Club. Almost all the great events which followed in rapid succession were determined by the voice of the club, whose deliberations were regarded with more interest than those of the Legislative Assembly. It reached the zenith of its power when the National Convention met in September 1792. The agitation for the death of the king, the storm which destroyed the Girondists, the excitement of the lowest classes against the *bourgeoisie* or middle classes, and the reign of terror over all France were the work of the Jacobins. But the overthrow of Robespierre on the 9th Thermidor 1794 gave also the deathblow to the Jacobin Club. The magic of its name was destroyed; and the Jacobins sought in vain to contend against a reaction which increased daily both in the Convention and among the people. A law of October 16 forbade the affiliation of clubs, and on November 9, 1794, the Jacobin Club was finally closed. Its place of meeting was soon after demolished.—The term Jacobins is often employed to designate persons of extreme revolutionary sentiments. For the *Anti-Jacobin*, see CANNING.

Jacobites (from the Lat. *Jacobus*, 'James'), the name given after the Revolution of 1688 to the adherents of the exiled Stuarts—James II. (1633-1701) and his son and two grandsons, James Francis Edward, the Chevalier de St George (1688-

1766), Charles Edward (1720-88), and Henry Benedict, Cardinal York (1725-1807). Those adherents were recruited from the Catholics, the Nonjurors, the High Churchmen and Tories generally, discontented and place-seeking Whigs, the Episcopalians and Highlanders of Scotland, and the great body of the Irish people. Oxford throughout was a great Jacobite centre, a zealous upholder of 'passive obedience' and the 'divine right of kings;' whilst Cambridge, on the other hand, was all for a Protestant succession. First came the battle of Killiecrankie (1689), where fell Graham of Claverhouse, and the Irish campaign (1690-91), with its battle of the Boyne and the treaty of Limerick; next, in 1696, the Assassination Plot, the chief actor in which, Sir George Barclay, escaped, but for which Sir John Fenwick, Sir William Parkyns, and Sir John Friend were executed. Then in 1715 there was the twofold rebellion—one in the Highlands under the Earl of Mar, another in the Border country under Thomas Forster, M.P., and the Earl of Derwentwater. Both practically ended, in spite of the Chevalier's subsequent landing, on the self-same day (13th November) with the indecisive battle of Sheriffmuir and the surrender at Preston, where nearly two-thirds of the 1500 prisoners were Scots. Seven nobles were sentenced to death, but only Kenmore and Derwentwater suffered, Nairn, Carnwath, and Widdrington being reprieved, and Nithsdale and Wintoun escaping from prison, as likewise did Forster. Not for the first or the last time, the inferior prisoners fared worse than the principals, twenty-six being executed, while over a thousand submitted to the king's mercy, and petitioned to be transported to the American plantations. Alberoni's expedition to the West Highlands (1719), with its 'battle' of Glenshiel, was a petty affair compared with the '15 or with the nine months' rebellion of the '45, whose hero throughout, as indeed of the whole Jacobite movement, was 'Bonny Prince Charlie.' It opened with his landing in the Hebrides (23d July), and closed with his crushing defeat at Culloden (16th April 1746), intermediate events being the victory of Prestonpans, the capture of Carlisle, the raising of the Manchester regiment, the turning at Derby (6th December), and the victory of Falkirk. This, more than the '15 even, was mainly a Scottish, mainly indeed a Highland, rebellion. The English Jacobites as a body held aloof; and of the chief victims beheaded, one only, Charles Radclyffe (Derwentwater's brother), was an Englishman. The others were the Earl of Kilmarnock, Lord Balmerino, Sir John Wedderburn, and Lord Lovat. The Earls of Cromartie and Traquair were let off, and nearly a thousand prisoners had their death-sentence commuted to transportation or forced enlistment; but fifty were hanged. In stout old Balmerino's avowal, 'If the Great Mogul had set up his standard I should have followed it, for I could not starve,' we see one type of the Jacobite; another, much baser, was Lovat, who played for a dukedom, whilst hoping to risk nothing, for he sent his son off to fight, and himself stayed at home. The last Jacobite hanged (on 7th June 1753) was Dr Archibald Cameron, brother to Lochiel; and in 1772 the last of the Jacobite heads fell down from its spike upon Temple Bar.

This sketch by no means exhausts the list of notable Jacobites, which comprised at one time or another Jeremy Collier, Sacheverel, Charles Leslie, Bolingbroke, Harley, Ormond, Marshal Keith, Rob Roy, William Law, Bishop Atterbury, Carte, Hearne, Dr King, Patten and Murray of Broughton (the two Julians of the '15 and the '45), Flora Macdonald, Sir Robert Strange, and Samuel Johnson. One remembers the Doctor's words about his pension (1762): 'Now that I have it,

I am the same man in every respect that I have ever been; I retain the same principles. It is true that I cannot now curse [smiling] the House of Hanover, nor would it be decent for me to drink King James's health in the wine that King George gives me money to pay for. But, sir, I think that the pleasure of cursing the House of Hanover and drinking King James's health are amply over-balanced by three hundred pounds a year.' There spoke an honest Jacobite, and there too spoke the spirit of the age. Jacobitism might linger on as a tradition among the Nonjurors, the very last of whose bishops died in 1805; but as an active principle it had long since become extinct, the reason of such extinction being less the disasters of its adherents or the worthlessness of the cause than the growing prosperity of the nation at large. *Bravi possidentes* had a double application, to subjects no less than to sovereigns.

The posthumous Jacobitism of the 19th century—'Charlie o'er the Water nonsense,' as Borrow terms it—was largely an outcome of Scott's splendid romance, *Waverley* (1814); and many, perhaps most of our best-known Jacobite lyrics were composed by post-Jacobite poets—Burns, Scott, Hogg, Lady Nairne, William Glen, Allan Cunningham, &c. This same 19th century, which has heard mass of requiem said for Prince Charles Edward by a Protestant minister (1888), and which has seen the Stuart Exhibition (1888-89), has not been without its two Stuart pretenders. They were 'John Sobieski Stollberg Stuart, Count d'Albanie' (1795-1872), and his brother 'Charles Edward, Count d'Albanie' (1799-1880), who were certainly the sons of Lieutenant Thomas Allen, R.N., and who claimed that he was the son of the young Chevalier.

See the article STEWART (with works there cited) for the exiled Stuarts; other articles on persons and events mentioned above, and on William III., Anne, George I., II., III.; the histories of Macaulay, Stanhope, Hill Burton, Lecky, and C. S. Terry; the *Culloden Papers* (1815); Hogg's *Jacobite Relics* (1819); R. Chambers's *Jacobite Memoirs* (1834), and *History of the Rebellion of 1745* (1828; 7th ed. 1870); Jesse's *Memoirs of the Pretenders and their Adherents* (1845); Mrs Thomson's *Memoirs of the Jacobites* (1845-46); Dr Doran's *London in Jacobite Times* (1877); W. K. Dickson, *The Jacobite Attempt of 1719* (Scot. Hist. Soc., 1895); Bishop Forbes, *The Lion in Mourning* (Scot. Hist. Soc., 3 vols., 1895-96); and A. Lang's *Prince Charles Edward* (1900).

Jacobites, in Church History. See GREEK CHURCH, Vol. V. p. 398.

Jacob's Ladder (*Polemonium aculeum*), a herbaceous perennial plant of the natural order Polemoniaceae, common in the centre and south of Europe, and found also in the temperate parts of Asia and North America. It has a smooth stem $\frac{1}{2}$ to 2 feet high, and a terminal panicle of bright blue (sometimes white) flowers, with wheel-shaped 5-lobed corolla. Great medicinal virtues were once ascribed to it, but the only quality which it seems to possess is a slight astringency.

Jacobus, a gold coin, of the value of twenty-five shillings sterling, struck in the reign of James I. (1603-25).

Jacotot, JEAN JOSEPH, the inventor of the 'universal method' of education, was born at Dijon, in France, on 4th March 1770. In the course of his chequered career he was successively soldier, deputy-director of the Polytechnic School, military secretary, and the holder of various professorial chairs, as of Mathematics, Roman Law, &c. He retired to Belgium in 1815, and three years later was appointed lecturer on the French language in the university of Louvain, and afterwards director of the military Normal School. He died at Paris, 30th July 1840. The fundamental

principles upon which his system of education rests are that the mental capacities of all men are equal; the unequal results of education depend almost exclusively upon will; every person is able to educate himself, provided he is once started in the right way; knowledge should be acquired in the first place through instinctive experience, or by the memory. For example, in imparting a knowledge of a language, he began by making the pupil commit to memory a single passage; then he encouraged him to study for himself, first the separate words, then the letters, then the grammar, and lastly the full meaning and import. Jacotot's system has some points of resemblance to Hamilton's (see HAMILTON, JAMES). He expounded his views in *Enseignement Universel* (1823). See Life by A. Guillard (Paris, 1860).

Jacquard Loom, named after the inventor, Joseph Marie Jacquard (1752-1834). See WEAVING.

Jacquemart, JULES (1837-80), French etcher. See ENGRAVING, Vol. IV. p. 380.

Jacquerie, the name given to an insurrection of peasants in France in 1358, when the French king John was a prisoner in England. The nobles called the peasants contemptuously 'Jacques Bonhomme'; hence the word Jacquerie. The rising was caused by long-continued oppression on the part of the nobles. It broke out in the neighbourhood of Paris, but extended to the banks of the Marne and the Oise. The magnitude of the danger forced the nobles to make common cause, and on 9th June the peasants were defeated with great slaughter near Meaux. This put an end to the insurrection.

Jactitation of Marriage is a false pretence of being married to another—a wrong for which the party injured could formerly obtain redress by a suit in the Ecclesiastical Court. Jurisdiction in such suits now belongs to the Probate and Divorce Division of the High Court of Justice; but the suit is unknown in modern practice, the English law being clear enough to enable parties to ascertain without litigation whether they are married or not. In Scotland, where the law is not so clear, the suit of declarator of putting to silence (i.e. putting an end to pretended claims) answers the same purpose as a suit for jactitation. Thus, in the famous Yelverton case (1861) the lady's action for declarator of marriage was met by a cross-action for declarator of putting to silence.

Jade is a name applied to about 150 varieties of ornamental stones, but should be properly restricted to the mineral Nephrite (q.v.), so called from the Greek *nephros* because it was supposed by the ancients to have virtue in renal diseases. The name is from the Spanish *ipada*, 'the flank' (from the Latin *ilica*), because it was believed to cure pain in the side; and the mineral was brought by the Spaniards from Mexico. True jade is a native silicate of calcium and magnesium, tough, and of various shades of green, yellowish-gray, and greenish-white. It is never crystalline, and it is very hard, but not excessively so, and is remarkable for being less hard when freshly broken than after exposure. The specific gravity varies from 2.91 to 3.06. Jade has been reported in isolated cases in Prussia, Turkey, and Corsica, but important deposits are unknown in Europe. It is principally found in China, Siberia, New Zealand, and in some of the islands of the South Pacific, while its occurrence has also been reported in British Columbia and Alaska. Although jade ornaments were brought by the Spaniards from Central and South America, the mineral is not found there *in situ*. It is doubtful, moreover, if the majority of these reputed jade ornaments were

of true jade. The 'Amazon-stone,' for instance, is not, but is a variety of microcline felspar, while the 'Bowenite' of North America is really a variety of serpentine. Many objects exported from China as of jade are really of serpentine. A variety of jade found in New Caledonia and the Marquesas is known as 'Oceanic jade,' differing from the oriental variety in the proportions of lime and magnesia. The New Zealand jade also differs from the Asiatic, and many of the stones used by the Maoris known as *haua-kawa* do not contain some of the inseparable ingredients of true jade. The real jade found in New Zealand is known to the Maoris as the *puatani* or 'green-stone,' and is found along the west coast of the south island. They work it into amulets, ornaments, and even axe-heads on account of its hardness. In New Caledonia and some of the other Pacific islands jade is also used for axe-heads, and thus has become known to mineralogists as axe-stone.

Nowhere is jade found so extensively and prized so highly as in China. And yet a good deal of the so-called China jade is really jadeite—which is a silicate of alumina and sodium, and therefore a different chemical compound from true jade. Jadeite has a brighter colour, and is harder than jade, while its sp. gr. ranges from 3.28 to 3.35. Jadeite is also found in Burma, near Blamo, and is doubtless the substance of which many of the old Mexican and Central American ornaments were made. An Egyptian scarabæus in jadeite has been found, and axes of jadeite have been discovered in the lake-dwellings of central Europe, although the mineral itself is unknown in Europe.

In China jade is most ingeniously and elaborately carved. It is called *Yu-chi*, or 'yu-stone,' and has for ages been obtained from the Kuen-lun Mountains, where it is found in veins among the schistose and gneissose rocks of the Kura-kash, and the south of the Khotan province. Jade from that district has been known to the Chinese for over two thousand years. Very fine dark-green jade is found near Batongol, in Siberia, in boulders.

The mines of Chinese Turkestan are, so far as is known, the only mines which are regularly worked. There are over one hundred of them, riddling one large mountain-side with dark tunnels, giving access to long galleries winding in all directions; in some cases piercing right through to the other side of the mountain. The mineral is found in veins several feet in thickness, but so full of fissures that perfect blocks are not often found of more than a few inches thick. It is for this reason that large pieces are so valuable, and are usually reserved for the imperial tribute. At Canton there is a great jade market, where the mineral itself as well as all sorts of articles made from it are on sale. The ornaments are mostly bracelets, brooches, ear-rings, finger-rings, and hairpins, and these are as dear to the Chinese ladies as diamonds are to their Caucasian sisters. A necklace of green jade beads will cost £1000; two buttons suitable for a mandarin will fetch £30; while for a moderate-sized piece of the vivid green, which is much sought after, from £500 to £600 will be paid. The stone is exceedingly difficult to work, and hence the great cost of carved specimens; but even at Moulien a pair of rough bracelets, not of the finest quality, will fetch £20 or £30.

Jade ornaments have been found among the lake-dwellings of Switzerland—at the lakes of Biemme, Zurich, and Pfaffikon; stone celts have been found in dolmens in France which resemble jadeite, but with a larger proportion of iron, and are now known as *chloromachadite*; and implements of the Neolithic age in western Europe, once supposed to be of jade, are now recognised as of *fibrolite* (a silicate of aluminium, sp. gr. 3.2).

There is no natural jade among the rock formations of Switzerland, so that the ornaments of the lake-dwellers must either have been brought by their ancestors from Asia, or have been obtained in barter from some of the nomadic races of pre-historic times. Dr Schliemann reported jade celts among the ruins at Hisarlik, and in the British Museum there is a seal-cylinder of jade among the Assyrian and Babylonian relics. The jade ornaments of India must have been brought from central Asia.

See Fischer, *Nephrit und Jadit* (2d ed. Stuttgart, 1881); Meyer's Catalogue of Jade Articles in Dresden Museum (Leip. 1882-83); and Miss Gordon-Cumming's *Wanderings in China* (1885).

Jacl. See DEBORAH.

Jaen, a city of Spain, capital of the province of the same name, is picturesquely situated on a tributary of the Guadalquivir, 50 miles N. by W. of Granada. Its old Moorish walls are fast crumbling away. It is the see of a bishop; the cathedral dates from 1532. Pop. (1884) 21,280. By the Moors the town was called *Jayyenu-Uharir*, 'Jaen of the Silk,' on account of its silk manufactures, for which, however, it is no longer famous.—The province (area, 5184 sq. m.; pop. in 1887, 437,842), part of Andalusia (q.v.), lies wholly within the basin of the Guadalquivir, and is for the most part mountainous. Conquered by the Moors on their entrance into Spain, Jaen maintained its independence as a Moorish state till 1246, when it fell into the hands of Ferdinand III. of Castile.

Jaffa, or JOPPA (Heb. *Yafa*; in New Testament, *Ioppé*; Arab. *Yafa*), a town on the sea-coast of Syria, 53 miles NW. of Jerusalem, of which it was the port in King David's time. Hence Jonah sailed for Tarshish; here Peter had his vision. Under Constantine the place, which had been destroyed by Vespasian, became a bishop's see, and, as the great landing-place of the Crusaders, was taken and retaken by Christian and Moslem. In 1799 Napoleon stormed it and massacred his prisoners; in 1832 it was taken by Mehemet Ali, and restored to the Turks by British help. The open roadstead, the ancient walls, the yellow sand-dunes, and the extensive orange gardens are now the chief features of the brown town on its hillock, which possesses several European consulates; a landing-stage and custom-house were erected in 1888. There is a carriage way to Jerusalem (the toll of which was let for £2000 in 1888), and a railway was opened in August 1892. The population increased from 15,000 to 40,000 between 1883 and 1896, while the export of oranges increased threefold, largely through the German colony of 300 persons established here in 1869. The total exports (wheat and fruit) are worth about £500,000 a year.

Jaffnapatam, a seaport in the extreme north of Ceylon, on an island of the same name, has been peopled by Tamils for more than 2000 years. Pop. (1891) 43,902. A large sprinkling of the European population are of Dutch descent.

Jagatai, a central-Asiatic dialect of Turkish. See TURKS.

Jagellons, the name of an illustrious dynasty which reigned in Lithuania, Poland, Hungary, and Bohemia. The name is derived from Jagello, the last of a line of hereditary grand-dukes of Lithuania, who succeeded to his patrimonial possession in 1381, and was (1386) appointed successor to his father-in-law, Louis the Great, king of Poland and Hungary, in the former of these kingdoms, after having embraced Christianity, and changed his name to Ladislaus II. He was succeeded on the throne of Poland by six kings of his house, the last of whom, Sigismund Augustus, died in 1572. Through a sister of the last, however, the Jagellon

dynasty was continued on the Polish throne till 1668. See POLAND.

Ladislans, the fourth son of the Jagellon Casimir IV. of Poland, was elected king of Bohemia in 1471, on the death of George Podiebrad, and also succeeded Mathias Corvinus in Hungary in 1490. Ladislans died in 1516, and was succeeded in both kingdoms by his son, Louis II., who was defeated and slain by the Turks at Mohacs (29th August 1526), and with whom terminated the Jagellons of Bohemia and Hungary.

Jägerndorf, a town of Austrian Silesia, close to the frontier, by rail 34 miles W. of Ratibor and 18 N.W. of Troppau, has manufactures of woollen cloth, linen, organs, &c. Pop. 14,792. From 1377 there was an independent principality of Jägerndorf; in 1742 its territories were divided between Prussia and Austria.

Jaggernaut. See JUGGERNAUT.

Jaggery. See DATE PALM.

Jaguar (*Felis onca*), one of the largest and most beautiful of the Felidae, and by far the strongest and fiercest of the American beasts of

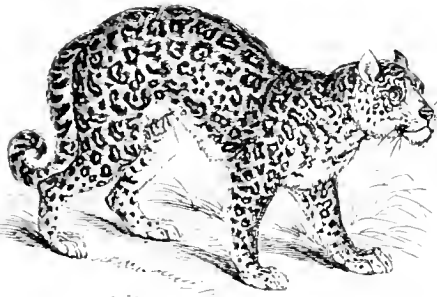

Jaguar (*Felis onca*).

prey. The jaguar is nearly equal to the tiger in size, but is less massive, and has shorter legs. The soft, rich fur varies in colour from yellowish-white to very dark brown or black; the sides, shoulders, and thighs are marked with dark ring-like spots, larger, and arranged in more regular patterns than those of the leopard. Each ring usually encloses several small black points. The black-furred jaguar is sometimes regarded as a different species, but the characteristic markings can be seen in certain lights, and the ground-colour varies greatly even in members of the same litter. The jaguar is found all over South America except in some parts of Patagonia, and in North America as far north as the borders of Texas and South California, inhabiting chiefly the outskirts of forests and the shady banks of rivers and lakes. The food of the jaguar is very varied. Wild horses and mules are his favourite prey, but birds, turtles, and fish are readily eaten, while he is often forced to depend for subsistence on the timid, stupid capybaras. The flesh of the peccary, too, is a dainty which he exercises all his ingenuity to procure, for even a jaguar dare not openly attack a herd of these comagous little pigs. His method, it is said, is to conceal himself in a tree till a herd passes, drop down on one and kill it, then spring into the tree again and wait patiently until the angry herd is a safe distance off. The jaguar is hunted sometimes with the lasso, but most frequently with dogs and poisoned arrows, and the skins are imported into Europe in large numbers.

Jahde, or JADE, a bay in the north of Oldenburg, now belonging to Prussia, which has con-

structed a naval station on its shores. See WILHELMSHAFEN.

Jahn, FRIEDRICH. See GYMNASTICS.

Jahn, JOHANN, a Catholic biblical critic, was born at Tasswitz, in Moravia, in 1750. He became professor of Oriental Languages at Olmütz, and, in 1789, at the university of Vienna; but the unwonted boldness of his criticism, as that Job, Tobit, and Judith were didactic poems, and that the New Testament demoniacal possession was the result of natural disease, although not formally condemned, led in 1806 to his honourable retirement to a canonry of St Stephen's, Vienna. He died August 16, 1816. Jahn was an industrious writer, and his *Einleitung ins Alte Testament* (1792), *Archæologia Biblica* (1805; Eng. trans. by T. C. Upham, 1840), and *Enchiridion Hermetice* (1812) were works really remarkable for their time and circumstances. Besides these he published many manuals on the grammar of Hebrew, Syriac, and Arabic, an edition of the Hebrew Bible (1806), and a commentary on the Messianic prophecies (1815).

Jahn, OTTO, a famous archaeologist and philologist, was born at Kiel, June 16, 1813, and studied at Kiel, Leipzig, and Berlin. He next travelled in France and Italy, making a lengthened stay in Rome, and returned in 1839 to lecture at Kiel, whence he was called to Greifswald. In 1847 he accepted the chair of Archaeology at Leipzig, and here he founded an archaeological society, and served as director of an archaeological museum. Deprived in 1851 for his part in the political movements of 1848-49, he became in 1855 professor of the Science of Antiquity, and director of the Academic Art Museum at Bonn, whence he was summoned in 1867 to fill Gerhard's chair at Berlin. He died, however, before entering on his new duties, at Göttingen, 9th September 1869.

Jahn's contributions to archaeology were numberless, and of the first importance. Here may only be named works on Polygnotus, *Die Hellenische Kunst* (1846), *Pytho* (1846); a description of the vases in King Ludwig's collection (1854), and works on the representations of ancient life on vases (1861, 1868); and a work on the evil eye (1850). His works in philology include editions of Persius (1843), Censorinus (1845), Florus (1852), *Pansaniæ descriptivæ Aristicis* (1860), the *Brutus* (1849) and *Orator* (1851) of Cicero, Juvenal (1851), the *Periplus* of Ptolemy (1853), the *Psyché et Cupido* of Apuleius (1856), the *Electra* of Sophocles (1861), the *Symposium* of Plato (1864), and Longinus (1867). Among his numerous other works may be named his elaborate and masterly biography of Mozart (1856-60), a contribution of the first importance to the history of music; *Gesammelte Aufsätze über Musik* (1866); and his *Biographische Aufsätze* (1866).

Jail Fever (known also as Putrid or Pestilential Fever) is now considered to be merely a severe form of Typhus Fever (q.v.), and not a distinct disease. At the present time, owing to improved sanitary regulations, this form of disease is almost unknown; but we learn from Howard's *Account of the State of Prisons* that, in his time, the disease was very frequent in the prisons of England, although unknown in those of the continental countries. In the celebrated Black Assize (q.v.), held at Oxford in 1577, there is no evidence that the disease prevailed among the prisoners, and yet it broke out among the persons present at the trial. So late as May 1750 the lord mayor, an alderman, two judges, most of the jury, and a large number of spectators caught this disease from attending the assizes at the Old Bailey; and many of those who were infected died.

Jains is the name of a heterodox sect of Hindus, found in most parts of Upper India, numerous more especially to the westward, but also scattered throughout the peninsula. They are important

from their wealth and influence rather than from their number. Their tenets are in several respects analogous to those of the Buddhists (see BUDHISM), but they resemble in others those of the Brahmanical Hindus. With the Buddhists they share in the denial of the divine origin and authority of the Veda. With the Brahmanical Hindus, on the other hand, they agree in admitting the institution of caste, in performing the essential ceremonies called *Sanskritas*, and in recognising some of the subordinate deities of the Hindu pantheon; but they disregard completely all those Brahmanical rites which involve the destruction of animal life.

According to their doctrine, all objects, material or abstract, are arranged under nine categories, called *Tattvas*, truths or principles, of which we need notice only the ninth and last, called *Moksha*, or liberation of the vital spirit from the bonds of action—i.e. final emancipation. In reference to it the Jains not only affirm that there is such a state of emancipation, but they define the size of the emancipated souls, the place where they live, their parts, natures, and numbers.

The principles of faith are common to all classes of Jains, but some differences occur in their duties, as they are divided into religious and lay orders, *Yatis* and *S'ravakas*. The *Yati* has to lead a life of abstinence, taciturnity, and continence; he should wear a thin cloth over his mouth, to prevent insects from flying into it, and he should carry a brush to sweep the place on which he is about to sit, to remove any living creature out of the way of danger; but, in turn, he may dispense with all acts of worship; whilst the *S'ravaka* has to add to the observance of the religious and moral duties the worship of the saints, and a profound reverence for his more pious brethren. The secular Jain must, like the ascetic, practise the four virtues—liberality, gentleness, piety, and penance; he must govern his mind, tongue, and acts; abstain, at certain seasons, from salt, flowers, green fruits, roots, honey, grapes, tobacco; drink water thrice strained, and never leave a liquid uncovered, lest an insect should be drowned in it; it is his duty also to visit daily a temple where some of the images of the Jain saints are placed, walk round it three times, make an obeisance to the image, and make some offerings of fruits or flowers. The reader in a Jain temple is a *Yati*, but the ministrant priest is not seldom a Brahman, since the Jains have no priests of their own.

The Jains fall into two principal divisions, *Digambaras* and *S'ravikambaras*. The former word means 'sky-clad,' or naked, but in the present day ascetics of this division wear coloured garments, and confine the disuse of clothes to the period of their meals. *S'ravikambara* means 'one who wears white garments;' but the points of difference between the two divisions are said to be 700, of which 84 are of paramount importance. In the south of India the Jains are divided into two castes; in Upper Hindustan they are all of one caste. It is remarkable, however, that amongst themselves they recognise a number of families between which no intermarriage can take place.

As regards the pantheon of the Jain creed, it is still more fantastical than that of the Brahmanical sects. The highest rank amongst their numberless hosts of divine beings—divided by them into four classes, with various subdivisions—they assign to the deified saints, which they call *Jina* (whence the usual name of the sect), or *Arhat*, or *Tirthakara*, besides a variety of other generic names. The Jains enumerate twenty-four Tirthakaras of their past age, twenty-four of the present, and twenty-four of the age to come; and they invest these holy personages with thirty-six superhuman attributes of

the most extravagant character. They distinguish the twenty-four Jinas of the present age from each other in colour, stature, and longevity. *Rishabha*, the first Jina of this age, was 500 poles in stature, and lived 8,400,000 great years; whereas *Mahavira*, the 24th, had degenerated to the size of a man, and was no more than forty years on earth. The present worship is almost restricted to the last two Tirthakaras. The old view, endorsed by Professor Weber, was that the Jains are a remnant of the Indian Buddhists who succeeded in maintaining their existence by a compromise with Hinduism. The Jains themselves strongly insist that their faith is older than Buddhism; and Jacobi proves from the Jain texts that Buddhism and Jainism were developed out of Brahmanism by a very gradual movement, Jainism being probably the earlier. Modern Jainism Sir W. W. Hunter describes as 'a religion allied in doctrine to ancient Buddhism, but humanised by saint worship.' In 1881 there were 448,897 Jains in British India.

See Oldenberg, *Budha* (Eng. trans. 1882); Thomas, *Jainism; or the Early Faith of Asoka* (1877); Rhys Davids, *Hibbert Lectures* (1881); Jacobi, *Jaina Sūtras* ('Sacred Books of the East,' Clar. Press, 1885); and for the numerous and beautiful Jain temples, see Fergusson's *Five Temples of India* (1880), and Burgess's *Buddhist and Jaina Caves* (2 vols. 1881-83).

Jaipur. See JEYPORE.

Jaisalmer (*Jaysulmere*), capital of the native Indian state of Jaisalmer, in Rajputana, stands on the edge of the Indian Desert, and was founded in 1156. It has several Jain temples. Pop. 10,965.—The state of Jaisalmer contains an area of 16,447 sq. m., and 108,143 inhabitants.

Jakutsk. See YAKUTSK.

Jalalpur, a town of India, 8 miles NE. of the city of Gujrat in the Punjab, noted for its shawl manufacture; pop. 12,839.—There is another ancient and ruined Jalalpur on the Jhelum River.

Jalandhar. See JULLUNDER.

Jalap, a well-known purgative medicine, is the root of *Ipomoea purga*, a plant of the natural order Convolvulaceae. It is a native of the eastern slopes of the Mexican sierras, growing at an elevation of about 6000 feet. Named from the town of Jalapa, it is a perennial twining plant, with large flowers and a turnip-like root, varying from the size of a hazel-nut to that of a man's fist. The roots when fresh are white and fleshy, and abound in a milky juice. They are dug up at all seasons of the year, and hence one great cause of their variation in size and activity. After being dried the roots are brown and wrinkled externally, of a deep yellowish-gray colour internally, and have the consistence of wood. Their odour is faint and disagreeable, and the taste is nauseous. For use in medicine the roots are finely powdered. Jalap-root contains starch, sugar, lignin, and other ingredients, but the active principle is a resin which is officinal



Jalap (*Ipomoea purga*):
a, the root.

under the name of *Jalapu Resina*. The amount of this resin varies from 12 to 21 per cent. It is extracted from the root by means of dilute alcohol, and consists chiefly of a body called convolvulin. Jalap is a hydragogue cathartic, and may be given alone or in combination with calomel or cream of tartar. It and its preparations are used in constipation, renal disease, and cerebral affections. Its action is limited to the production of severe purgation. Jalap was first used in England about the beginning of the 17th century. The ordinary dose of powdered jalap for an adult varies from ten to thirty grains, a scruple generally acting smartly and safely; for children under a year old the dose is from two to five grains. The dose of the compound powder is double that of the ordinary powder.

Jalapa, capital of the Mexican state of Vera Cruz, is 60 miles by rail NW. of Vera Cruz city. It is situated in a charming and fertile district, in a healthy and temperate climate, 4330 feet above the sea, and is neatly built and surrounded with pleasant gardens. The principal buildings are the old Franciscan monastery (1536), the church of St Joseph, a hospital, and the government offices. Pop. (1888) 14,000.

Jalisco, a state of Mexico, on the Pacific, with an area of 38,840 sq. m. It is traversed by the Sierra Madre, and in great part forms a plateau. The climate is healthy away from the coast. The principal river is the Rio Grande de Santiago; in the south-east is the lake of Chapala (q.v.). Silver and copper mining and agriculture have been the chief industries; but within recent years a number of cotton, woollen, paper, and tobacco factories have been established. Pop. (1879) 983,484; (1895) 1,107,863. The capital is Guadalajara (q.v.).

Jalna, a town and British cantonment in the Nizam's Dominions, India, 210 miles NE. of Bombay. Its fruit is celebrated, being sent to Hyderabad, Bombay, and other large towns. Pop. of town, 6258; and of cantonment, 9933.

Jam. See PRESERVED PROVISIONS.

Jamaica, aboriginally *Xaymaca* ('Land of Springs'), one of the West India Islands, and by far the most important of those belonging to Great Britain, is about 90 miles to the south of Cuba, and stretches between 17° 43' and 18° 32' N. lat., and between 76° 11' and 78° 20' W. long. It is divided into three counties, Surrey in the east, Middlesex in the middle, and Cornwall in the west; its area is 4193 sq. m., or a little more than the three English counties of the same names with Hampshire thrown in. The greatest length is 144 miles; the greatest breadth, 50 miles. Turk's and Cadeo's Islands, as well as the three Cayman Islands, are dependencies of Jamaica. The island is traversed from east to west by the Blue Mountains, which rise to 7400 feet. From this range nearly 120 streams descend to the coasts, but owing to the shortness and steepness of their courses they are not navigable, with the exception of Black River, which affords, for small craft, a passage into the interior for 30 miles. Excellent harbours are everywhere to be found. Incomparably the best of these is Kingston (q.v.) harbour, a deep and capacious basin in the south-east quarter of the island. Jamaica is believed to be rich in mineral wealth, but no minerals are extracted. The chief towns are Kingston (pop. 46,542), the capital, and Spanish Town, formerly the seat of the government (pop. 5019), on the south-east of the island; and Montego Bay (pop. 4863), Savanna-la-Mar (2952), on the south-west, and Edmouthe (pop. 2517). Port Royal, situated at the western extremity of the spit of sand that shuts in the

harbour of Kingston on the south, which, previous to the great earthquake of 1692, was one of the chief cities in the West Indies, is now a place of only 1200 inhabitants, though still a naval station.

The climate varies considerably, falling on an average 1° for every 300 feet in altitude. At Kingston, on the coast, the thermometer is nearly all the year round at 70 during the night and 90 during the day, the mean thus being 80° or 81°; but the heat is tempered by the sea-breezes. A corresponding regularity is observable in the upland regions. On the whole, the island is very healthy; invalids even come from the United States to enjoy the benefit of the salubrious air of the interior.

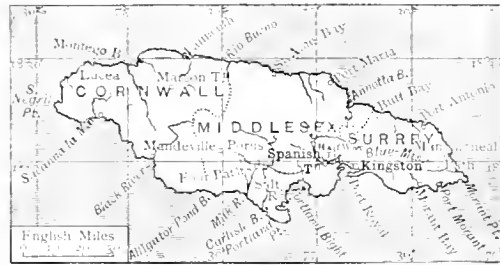

There are two rainy seasons, one in the middle of spring and the other towards the middle and end of summer. In the latter the rains are exceptionally heavy; violent thunder-storms are frequent, and hurricanes sometimes occur. A cyclone in 1880 did damage to the extent of more than a million sterling.

The vegetation is very luxuriant. The primeval woods are rapidly disappearing; yet there are still many valuable trees, such as balata, mahogany, logwood, lignum vite, fustic, ebony, pimento, cocoa-nut and other palms, cactuses, &c. Tropical fruits are grown in great variety, also many of the fruits of more temperate climes. Fruits were exported to the value of £347,652 in 1888 (£39,451 in 1878). Spices, dye-woods, medicinal plants, and food plants, such as ginger, cochineal, castor-oil, arrowroot, maize, vanilla, pimento (all-pee), &c., are extensively grown. A large extent of the cultivated area (one-fifth) is devoted to the growing of Guinea grass. This and pasture land occupy the greater portion of the north and west of the island. In the south and east the principal crops are sugar (33,600 acres in 1888, 12,800 less than in 1878), coffee, vegetables, and fruits. A little cinchona and cacao are also grown. The mongoose, imported to prey on the rats that infested the sugar estates, has, after exterminating the rats, become a plague, and has nearly extirpated lizards, harmless snakes, and small birds, so that insect pests (especially the troublesome ticks) abound. The negroes, who are mostly small holders, are the chief growers of fruit. The exports, which consist chiefly of dye-woods, fruits (oranges, lemons, bananas, pine-apples, &c.), sugar and rum, coffee, ginger, all-pee, and cocoa, average fully 1½ million annually; whilst the imports, consisting of food-stuffs, clothing, hardware, liquors, coals, building materials, &c., reach pretty nearly the same value. About 40 per cent. of the trade is with the United Kingdom, and the share with the United States 43 per cent.

During the past thirty years the white inhabitants have increased far less rapidly in numbers than the black and coloured population. In 1861 the total population was 441,255 (13,816 white and 427,439 black and coloured); in 1871 the figures were respectively 506,154 (13,101 and 493,053); and in 1881, 580,801 (14,432 and 551,132, besides

Chinese and others, and 11,016 immigrant coolies). In 1891 the population had increased to 639,491. By religion 32,300 belong to the Church of England, 30,000 are Baptists, 22,000 Methodists, 10,800 Presbyterians, 9290 Roman Catholics, 16,000 of the Moravian Church, and 9900 of other churches—children being excluded. In 1895 there were 924 government schools, with 98,359 pupils; besides two government training colleges for teachers. Secondary education is left to private initiative. Jamaica has 185 miles of railway and 950 miles of telegraph. The total exports in 1896 had a value of £1,470,241; the imports of £1,856,378. The defences of the island include a British garrison (the West India regiments) of more than 1000 men, a volunteer force of 600, and numerous coast batteries. There is also a semi-military police force of about 700 men. The public debt of the island amounted to £2,220,089 in 1896. The government is in the hands of a governor appointed by the Queen, assisted by a privy-council (which fulfils the offices of an executive) and a legislative council, both partly elective, partly nominated by the Queen or the governor.

Jamaica was discovered by Columbus in 1494, and definitely taken possession of by the Spaniards in 1509. The original inhabitants were peace-loving Indians (not Caribs); but they were practically extinct in 1655, when the island was conquered by the English, an expedition having been sent out for that purpose by Oliver Cromwell, under Admiral Penn and Venables. Jamaica was formally ceded to England by the treaty of Madrid in 1670. The place of the native Indians was taken by negro slaves, imported by the Spaniards, and by Irish and colonial immigrants, who arrived soon after the capture of the island. During the 18th century more than half a million slaves were brought over from Africa. Under English rule the chief events in the history of Jamaica were frequent rebellions of the Maroons, a community of runaway slaves, who had obtained a tract of land on the north side of the island; in 1831-32, a negro insurrection; and on August 1, 1834, the emancipation of the slaves, Jamaica receiving £6,161,927 as her share of the compensation money. The chief result of this last event was to ruin the sugar-growing of Jamaica, principally owing to the difficulty of procuring labour. The negroes refused to work, now they were free. The liberation was followed by concessions of representative and constitutional rights to the newly-liberated slaves. But the experiment proved a failure. The negroes considered it a grievance that offices in the magistracy were not more frequently conferred on them. They wished to suppress coolie immigration, which tended to keep down wages. They sought to obtain land without rent. The more violent even suggested the expulsion of the whole white population of the island. In 1865 the discontent was at its height. In October of that year the negroes rose in revolt and massacred twenty-three whites. Martial law was proclaimed by Governor Eyre, who suppressed the rising with resolute vigour, though the punishments inflicted on the rioters were in some cases perhaps unnecessarily severe. For the course he had taken Governor Eyre was thanked by the Jamaica Assembly; but in England a different view was taken of his conduct (see EYRE). He was recalled, and the representative constitution was suspended. A new constitution was framed in 1866, under which the island is now governed like an ordinary crown colony. There seems to be good authority for the statement that from the catastrophe of 1865 a new life has sprung. Crime has diminished; and education has everywhere advanced among the black population. A collection of Jamaica products was exhibited

with very satisfactory results at the Philadelphia Exhibition of 1876; and an exhibition in Jamaica of native products was opened in the autumn of 1890. New roads have been formed, harbours are being constructed, and the Rio Cobre irrigation canal, begun in 1872, will give fertility to 50,000 acres of the plain between Spanish Town and Kingston. Thanks to the Cuban refugees who have taken several of the long-forsaken sugar estates, property is looking up, and the official statements show that the export trade is increasing, though slowly. Although Jamaica has not recovered its former commercial prosperity, the negroes cannot now be described as idle. They cultivate their provision grounds with care, and are especially active in developing the fruit trade. Extreme poverty is unknown among them, and they are described as a law-abiding and inoffensive community. See the *Jamaica Handbook*, issued at the government printing-office, Kingston; and *Harpur's Magazine*, 1890.

Jamaica Bark. See CARIBBEE BARK.

Jamaica Pepper. See PIMENTO.

Jambusar, a town of British India, presidency of Bombay, is situated 30 miles SW. of Baroda. Pop. 11,479. Cotton is prepared for export.

James, the name of at least three persons who took an active part in the foundation of the early Christian church: (1) James the Elder, son of the fisherman Zebedee and brother of John, one of the three chief among the twelve apostles, put to death by the sword under Herod Agrippa, 44 A.D. His day falls on July 25; in the Greek Church, on April 30. According to a baseless legend he journeyed to Spain; whence, as Santiago, he is revered as the patron saint of that country. (2) James the Younger (the Little, not the Less), son of Alphaeus, was likewise an apostle, and is honoured in the Greek Church on October 9; by the Catholics, along with Philip, on May 1. (3) James the Great, the eldest among the 'brethren' of Jesus, according to Josephus (*Ant.* xx. 9, 1) was stoned to death by command of the high-priest Ananus in 62 A.D., during the interval between the departure of Festus and the arrival of a new procurator. The last is identical with the James mentioned in Acts xii., xv., xxi., and Gal. i. 19, who was the head of the Christian community of Jerusalem, and, according to Hezequias, bore the surname of the Just. His day falls in the Greek Church on October 23. Most theologians consider him the author of the epistle which bears his name, although it has been ascribed to both the others, to the son of Zebedee so late as 1876 in an able commentary by the Rev. F. T. Bassett.

The Epistle of James stands first among the *catholic* epistles, and is a kind of encyclical addressed in the first place to the twelve tribes which are scattered abroad, to the Jews of the Dispersion. It was written by a Jew for Jewish readers, all of whom are supposed to be subject to the Jewish law, and it was undoubtedly written early, perhaps about 50 A.D. at latest, certainly before the destruction of Jerusalem. It cannot, however, be proved, though generally assumed, that the epistle must have been written before Paul's first missionary journey, or before the Apostolic Council. Those who read into it a desire to counteract the effects of a misconstruction of St Paul's doctrine of justification by faith of course demand, as will be seen, a later date. The epistle was not admitted into the canon without some difficulty, and it is not much quoted by the earlier writers, Origen indeed being the earliest we find quoting it by name. Eusebius places it in his list of books controverted but

recognised by most (*Antilegomena*), and Jerome expresses the doubt more strongly still. Clement of Alexandria is silent about it, as also is Tertullian, nor is it mentioned in the Muratorian Fragment. But it was early acknowledged by the Syrian Church, and it is found in the Peshito; while there is abundance of less direct proof, as we find startling parallels and coincidences too numerous to be accidental in *The Shepherd* of Hermas, the Epistle of Clemens Romanus, and Irenæus. It was finally declared canonical by the third Council of Carthage (397), and already we find it acknowledged by Cyril of Jerusalem, Epiphanius of Cyprus, Athanasius, Gregory of Nazianzus, and all later theologians, down to the time of the Reformation, when it was rejected by Erasmus and Cardinal Cajetan, and stigmatised by Luther as 'a downright epistle of straw . . . with nothing evangelical about it,' from its supposed contradiction to his fundamental Pauline dogma of justification by faith alone. Calvin disputed this judgment, and maintained that the epistle was not unworthy of an apostle.

The aim of the epistle is throughout ethical rather than doctrinal, Christianity being prominently put forward as the ethical fulfilment of the law, the perfect man being he whose faith has constantly proved itself in practice, and who is patient under all tribulation. It echoes closely the language and method of Christ himself; as Beyschlag says, 'essentially it is the teaching of Christ,' and thus there is little teaching about Christ. Besides the discourses of the Master, especially his Sermon on the Mount, we find distinct traces of familiarity with the *Wisdom of Solomon*, and the *Ecclesiasticus* of the son of Sirach. Formalism, greed of gain, respect of persons, falsehood, evil-speaking, boasting, wrangling and bitterness in debate, attention to dogmatic definitions instead of holiness of life—such are the sins against which the author inveighs with vivid and abrupt invective. His Greek is unusually pure, and some scholars, as Schmidt, Bertholdt, and Bishop Wordsworth, have supposed that the epistle was first written in Aramaic and afterwards translated.

The passage in the second chapter (14-26) has been interpreted by many theologians as a direct attack on the Pauline view of faith and justification, that Christ by his death had accomplished a new order of salvation, in which the law, which was merely temporary, was now abrogated, and that thus Christianity had fitted itself to become a universal religion. But the undoubted difference of tone is rather that of a different point of view than of conscious contradiction, and had the writer had Paul's epistles before him we might well have expected that he would have said much more. Indeed the whole treatment suggests want of acquaintance with Paul's epistles far more than a criticism of his doctrine, and the works required by James are not at all the works of the law condemned by Paul. Paul's conception of faith is a complete spiritual communion with the Redeemer, effected by the free gift of God, in consequence of a profound conviction on the sinner's part of the saving merits of Christ's death, the source of a new holy life in Christ and of love at once to God and man. To James, again, faith is an assent of the thinking mind to the oneness of God and the Messianic work and vicarious sacrifice of Christ, a preliminary condition indeed of justification and eternal salvation, but yet something still to be made perfect by the good works which are the outward fruit of inward love. Good works are an external addition to faith, uniting with it and completing it, regarded as a necessary corollary to justification, rather than, as with Paul, a spon-

taneous and visible fruit of the conscientiousness of a completely new relation to God attained through an antecedent justification. To Paul, says Weiss, this is an act of grace in which righteousness is imputed to the sinner; to James, the act of a judge who by a judicial decision attests the righteousness as proved (Matt. xii. 37), and thus procures deliverance from destruction. Paul's conception is more philosophical and comprehensive, but it by no means excludes the conception of James, which is at once earlier in time and adapted in the first instance to a narrower circle of readers. Paul's emphatic definitions were meant to oppose the Judaizing party, who would have narrowed the largeness of Christian liberty by emphasising the necessity for the works of the Mosaic law; James meant to strike at the lingering Jewish notion that to be a child of Abraham was the most important consideration, and that besides this an intellectual assent to the special claims of Christ was sufficient. His faith without works is not Paul's justifying faith at all, but the profitless faith without love condemned in I Cor. xiii.

The Tübingen school, as might have been expected from its central assumption of an early opposition between the Jewish and Gentile parties in the Christian church, claimed the Epistle of James as a polemic against Paul, and made its author a pseudonymous writer of later time, who employed the name of James as an accepted type of spiritualised Jewish Christianity. Schwegler elaborated this view of the epistle much more fully than Baur himself, regarding it as a parallel to the Clementine Homilies. He makes the antithesis between rich and poor in the epistle refer to secularised Pauline Gentile Christianity, as contrasted with primitive Christian Ebionism, and further reads into the epistle polemical references to Gnosticism and the persecutions of the time of Trajan. Hausrath refers it to the same period, and considers it a direct answer of Jewish Christianity to the Epistle to the Hebrews. Hilgenfeld, again, pushes it back to the time of Domitian, explaining the wisdom attacked as Paulinism which had thrown the church into disunion by its doctrinal disputes, and the Christianity of the writer as Essene and Orphic in character. Holtzmann declares for the same date, maintaining the dependence of the epistle on the Pauline epistles together with the Epistle to the Hebrews and the Apocalypse, on the first Canonical Gospel, First Peter, and the Epistle of Clement, and explaining the rich as distinguished aspirants to Christianity. Similarly Von Soden places the epistle in the time of the Domitian persecutions, and pronounces the author, whom with Holtzmann and others he transfers to Rome, as of a kindred spirit with Clement and Hermas.

Besides the general introductions of Bleek, De Wette, S. Davidson, Hilgenfeld, Holtzmann, Salmon, Dods, and Weiss, and the works on the New Testament canon by Kirchofer, Overbeck, Westcott, and Zahn, may be consulted the special commentaries by P. T. Bassett (1876), Reuss (1878), Erdmann (1881), Schegg (1883), E. H. Plumptre (1884), Beyschlag (1888; 5th ed. of the com. in the *Ecce. Handbuch*); R. Johnstone (2d ed. 1888); and J. B. Mayor (1893). The question of the Brethren of the Lord is discussed under JOSEPH.

James I., king of Scotland (1406-37), the second and only surviving son of Robert III., was born at Dunfermline in 1394. His education was entrusted to the learned Bishop Wardlaw of St Andrews. His elder brother, David, Duke of Rothesay, a reckless and dissipated youth, had died at Falkland—it was strongly suspected, but not proved, a victim to the unprincipled ambition of his uncle, the Duke of Albany, and King Robert

resolved in 1406 to send his younger son for safety to France. But, though a truce at that time existed between England and Scotland, the vessel in which the young prince had embarked was seized by an English cruiser, and James and his attendants were carried to London, and committed to the Tower. He was detained a prisoner in England for the long space of eighteen years, no doubt with the connivance of the Duke of Albany, on whom the government of Scotland had devolved on the death of Robert III. in 1406. Henry IV. made some compensation for his cruel injustice to the young prince by carefully instructing him in all the knightly accomplishments of the age, and he not only became distinguished for his dexterity in martial exercises, but he could play well on the lute and harp and other musical instruments, was a skilful calligrapher, illuminator, and painter in miniature, and had also a considerable knowledge of medicine. On the death of the Duke of Albany in 1420, his son Murdoch succeeded to the regency. Under his feeble rule the country fell into a state of disorder, almost of anarchy, till at length Murdoch himself grew weary of his position, and took steps to procure the return of the lawful sovereign. The conditions of his release were definitely arranged May 12, 1423. It was stipulated that £40,000 was to be paid to defray the expense of his maintenance and education. James had in a singularly romantic manner gained the affections of Jane Beaufort, a daughter of the Earl of Somerset, niece of Richard II., and granddaughter of John of Gaunt; and on February 12, 1424, they were married with all the pomp befitting the occasion. The royal pair then set out for Scotland, and were welcomed with joyous acclamations.

James found his kingdom a scene of lawless excess and rapine, mainly owing to the weakness of the government and the turbulence of the nobles. He at once set himself to restore the legitimate authority of the crown, and to rescue the commons from oppression and plunder; but in carrying out these praiseworthy objects he sometimes lost sight of both mercy and justice. Eight months after his restoration he suddenly swooped down upon his cousin the former Regent Albany, two of his sons, and his aged father-in-law, the Earl of Lennox. They were brought to trial, but the nature of the charges against them is not known. They were found guilty and executed amid general compassion and regret; the people believed that it was simply an act of cruel revenge. James then seized and imprisoned fifty of the Highland chiefs, and put to death the most obnoxious ringleaders. He deprived the powerful Earl of March of his estates, and on the death of the Earl of Mar, the victor at Harlaw, he seized the earldom and annexed its immense estates to the crown. Meanwhile, into the parliament he introduced the principle of representation, and for the first time caused its acts to be published in the language of the common people. Its enactments, which were judicious and enlightened beyond the age, comprehended the subjects of agriculture, commerce, foreign and domestic manufactures, the regulation of weights and measures, the impartial administration of justice, and the police of the country. He renewed commercial intercourse with the Netherlands, and concluded a satisfactory treaty with Denmark, Norway, and Sweden. He drew closer the ancient bond of alliance with France, and gave his eldest daughter in marriage to the Dauphin. But he unfortunately persisted in carrying out harshly, and sometimes unjustly, his measures for curbing the power of the nobles, which excited not without cause strong discontent and apprehension among the whole body.

His confiscation of the earldom of Strathearn,

which had devolved on Patrick Graham, brought matters to a crisis. A conspiracy was formed against the king's life, headed by his uncle, the Earl of Athole; Sir Robert Stewart, his grandson; and Sir Robert Graham, uncle of the Earl of Strathearn, who had personal as well as family injuries to revenge. The plot was carried into effect at Perth on the 20th of February 1437. The king was about to retire for the night, when there was a great noise and clashing of arms heard, and a band of assassins led by Graham broke into the monastery of the Dominicans where the court was residing. The bolts had been removed from the chamber door, but Catharine Douglas heroically thrust her arm into the staple. It was instantly broken, and the ruffians burst into the chamber. The king, who had sought refuge in a vault under the floor, was discovered, and after a desperate resistance was cruelly murdered. The murderers were all apprehended in less than a month, and put to death by tortures shocking to humanity. By his wife, the heroine of the *Kingis Quair*, he left one son (his successor) and five daughters, one of whom, Marguerite d'Ecosse, dauphine of France, was a gifted poetess. James was unquestionably the ablest of the Stewart sovereigns, and was possessed of high poetical genius. His principal poem, entitled *The Kingis Quair* (i.e. the king's quire or book), is remarkable for elegance of diction and tender delicacy of feeling. The humorous pieces *Christ's Kirk on the Green* and *Pebblis to the Play* are much later compositions; but a 'Ballad of Good Counsel,' written, unlike *The Kingis Quair*, strictly in the Scottish dialect, is ascribed by Professor Skeat to James. See Professor Skeat's edition of *The Kingis Quair* (Scottish Text Soc. 1884), and Rossetti's noble ballad, 'The King's Tragedy.'

James II., king of Scotland (1437-60), was only six years old at the time of his father's murder. So alarming was the aspect of affairs that the queen-mother deemed it necessary to take shelter with her son in the castle of Edinburgh. Along with Sir Alexander Livingston of Callendar she was entrusted with the care of the young king; but Sir William Crichton, who was appointed Chancellor, and was governor of Edinburgh Castle, kept possession of his person, until the queen contrived to convey her son out of the fortress concealed in a chest, and took refuge with Livingston in Stirling Castle. Crichton was besieged in his stronghold, and compelled to make his submission. Meanwhile the country was brought to the verge of ruin by the feuds of the nobles, and the death of the Earl of Douglas in 1439 removed the only restraining power. Livingston availed himself of the marriage of the queen-dowager to Sir James Stewart of Lorn to compel her to resign her office as guardian of the king. Crichton and Livingston became reconciled, and were now the sole rulers of the kingdom, till in 1449 the young king assumed the reins of government. He displayed great prudence and vigour in the management of public affairs, and inflicted condign punishment on the Livingstons for their treatment of his mother.

The truce which had for some years existed between England and Scotland expired in 1448, and war was renewed on the Borders. Peace, however, was restored in the following year by the conclusion of a permanent truce. In June 1449 James married Mary, the only daughter of Arnold, Duke of Gueldres. He procured from the parliament a number of judicious enactments for the repression of outrages, the impartial administration of justice, the protection of the tenants of the feudal barons from summary ejection from their lands, and for the punishment of marauders. But his efforts to

promote the social welfare of the people were greatly obstructed and thwarted by the nobles, and especially by the Douglasses (see DOUGLAS); Earl William bent his whole energies to obtain pre-eminent position and power, and he entered into a treasonable bond with the Earls of Crawford and Ross. James invited him to the court at Stirling, and earnestly urged him to withdraw from his engagement with Crawford and Ross. Douglas in a haughty and insolent manner refused to comply with this request; and the king, whose temper was naturally fiery, lost all self-command, and stabbed the earl with his dagger. Some of the courtiers pierced his body with twenty-six wounds. After this atrocious murder the friends and vassals of the earl made war on the king until, by liberal promises of land and honours, Lord Hamilton and other powerful nobles were induced to abandon their cause; their estates were then forfeited, and they were compelled to take refuge in England. James was so irritated at the conduct of the Yorkist faction in protecting and pensioning the exiled Douglasses that he unwisely suffered himself to be entangled in the contest between the rival houses of York and Lancaster, and marched for England in 1460 at the head of a powerful army. He laid siege to Roxburgh Castle, which was at that time in the hands of the English, and was killed by the bursting of a cannon.

James III. (1460-88), born 10th July 1451, succeeded James II. in 1460. The guardianship of the young monarch was entrusted to his mother and Kennedy, Bishop of St Andrews, a prelate of great sagacity and integrity, while the Earl of Angus, chief of the 'Red Douglasses,' was made lieutenant-general. Under their management the government of the kingdom was carried on judiciously and successfully; but the death of the earl in 1462 and of the bishop in 1466, while the king was still a boy, left the country a prey to the factious and ambitious nobles, conspicuous among whom was Lord Boyd, high justiciar. Lord Boyd's son was created Earl of Arran, and in 1467 he obtained the hand of the king's sister, the Princess Margaret. The ambition and arrogance of the family, however, led to their downfall. The Earl of Arran fled to the Continent; and after his death, which took place apparently before 1472, the Princess Margaret married Lord Hamilton (1474), whose descendants became by this alliance the nearest heirs to the crown. When the king reached manhood the defects of his character became apparent. He had a refined and cultivated mind and fine tastes, was fond of mathematics and of music, and possessed great skill in architecture; but he was quite unfit to rule a country like Scotland at that period and to keep in order its rude and turbulent nobles. He was fond of money and of pleasure, and spent his time in the society of architects, painters, and musicians. The nobles were indignant at the slight thus put upon them, and attached themselves to the king's brothers, the Duke of Albany and the Earl of Mar, who were distinguished for their courage and skill in military exercises. James became jealous of their popularity and put them in prison, whence Albany escaped to the Continent, but Mar died in confinement. Albany had, in fact, aspired to the crown and had engaged to hold it as the vassal of Edward, king of England. In retaliation for an invasion of the country by an English fleet, James summoned the array of the kingdom to make an inroad into England. The army had advanced as far as Lauder when the disaffected nobles suddenly seized the royal favourites and hanged them on a bridge over the river Leader—Angus obtaining the name of Bell-the-Cat from his boldness in taking the initiative. Returning to Edinburgh, they committed the king a close prisoner to the castle of

Edinburgh. A reconciliation was effected between the king and his brother, but it was of short duration. The conspiracy among the nobles was speedily renewed. They rose in open rebellion, and induced the young heir to the throne to become their nominal head. The king was supported by the northern barons, but they were greatly outnumbered by the rebels. An encounter took place between the two bodies (11th June 1488) at Sauchiehall, about a mile from the famous field of Bannockburn. When the battle was going against the royalists the king galloped from the field, but was thrown from his horse at Beaton's Mill, and murdered. James left by his queen, Margaret of Denmark, three sons, the eldest of whom succeeded to the throne.

James IV. (1488-1513) was born in 1473. He was only in his sixteenth year when he was induced to join the disaffected barons in their rebellion against his father, but there is no reason to believe that he was a mere passive tool in their hands. The remorse which he felt on learning of his father's murder, shown by his wearing an iron chain round his waist and submitting to various other austerities by way of penance, affords conclusive evidence of his consciousness of guilt. His confederates in the rebellion, as might have been expected, turned their victory to their own advantage. They took possession of all the most important offices of state, of the money in the royal treasury, and of the late king's jewels. They had even the effrontery to accuse the loyal barons of treason, and to deprive them of their estates, which were divided among the leading conspirators.

When the young king reached maturity he exhibited great energy and good sense in the administration of public affairs, in vindicating law and punishing crime, in encouraging shipbuilding, and in developing the agriculture and manufactures of the country. He gradually withdrew his confidence from the barons who had used him as a tool to gain their own selfish ends, and transferred it to Sir Andrew Wood (q.v.) and other trustworthy counsellors. James vigilantly guarded against the encroachments of the papal court, and firmly asserted the ecclesiastical independence of his kingdom. His romantic and rash disposition induced him to support the cause of the impostor, Perkin Warbeck, who visited Scotland in 1495, and to invade England in his behalf. However, in 1497 a truce for seven years was concluded between the two kingdoms, and in August 1503 the Scottish king was married to Margaret, eldest daughter of Henry VII.—an alliance which led ultimately to the union of the crowns. James's affable manners, frank disposition, and splendid hospitality made him highly popular among his subjects, and his friendship was courted by foreign sovereigns. Henry VIII., who ascended the English throne in 1509, joined the league against France, while James adhered to the ancient alliance with that country. Petty disputes arose between the borderers of the two countries, and inroads were made on both sides. James was indignant at the capture of two privateers commanded by the famous Andrew Barton, who fell in an engagement with two English men-of-war, and all redress was refused by Henry. The French king, hard pressed by the Spanish and English armies, made strenuous efforts to obtain assistance from the Scots, and the French queen addressed a letter to James calling herself his mistress, and entreating him for her sake to advance three feet into English ground. He was unfortunately induced to comply with her request, and, disregarding the entreaties of his queen and the remonstrances of his counsellors, he summoned the army of his kingdom and invaded England in the summer of 1513. He lingered about the Borders until the Earl of Surrey had collected a powerful army to repel the invasion. A

battle took place at Flodden (q.v.), 9th September, in which the Scottish king and the flower of his nobility and gentry lost their lives. James possessed excellent abilities and great accomplishments, but he was headstrong, obstinate, and impatient of contradiction, licentious, fond of pleasure, and profuse in his expenditure. See Gregory Smith's *Days of James IV.* (1890).

James V. (1513-42), who was born on the 10th of April 1512, ascended the throne at a most critical period; for, though contrary to expectation the Earl of Surrey did not invade Scotland, the kingdom was torn by intestine feuds between rival factions. The queen-dowager, headstrong and passionate, was appointed regent. About eight months after the king's death she gave birth to a son, who died in infancy; and four months later she married the young Earl of Angus, head of the Douglas family. Her marriage put an end to her regency, and the Duke of Albany, son of the younger brother of James III., was invited from France and chosen in her room. Amid the contentions of the rival French and English factions, and the private quarrels of the nobles, the country was reduced to a state of almost total anarchy. The intrigues of Henry contributed not a little to foment the prevailing disorders. Albany, who insisted on revisiting France, returned after the lapse of a few months to find the Hamiltons and Douglasses at open war; and, after vain efforts to assert the authority of the government, he obtained permission in the beginning of 1524 to revisit France for a limited period, but did not return. Meanwhile the young king had been placed under the care of the poet Sir David Lyndsay, who instructed him in all manly and liberal accomplishments; but his mother interrupted his education, and, with the assistance of her brother Henry VIII. in 1524, when James had reached his thirteenth year, put him at the head of the government in order that she and her faction might misgovern the kingdom in his name. She had now become tired of her husband, and after a good deal of difficulty she succeeded in obtaining a divorce from him, and married young Henry Stewart, a son of Lord Avondale. In the following year the custody of the young king fell into the hands of the Douglasses, who kept him a close prisoner until he made his escape in 1528, and assumed the position of an independent sovereign. He displayed great firmness and resolution in carrying out his judicious policy, though unfortunately his morals had been deeply injured by the manner in which the base sycophants of the court had pandered to his passions. He expelled from the kingdom the Douglasses, who had entered into a traitorous league with England, severely punished the Border freebooters, chastised the insurgent Highlanders, renewed the ancient commercial treaty between Scotland and the Netherlands, instituted the College of Justice, and took measures to protect the peasantry against the tyranny of the barons. His sympathy with the common people and his habit of visiting their houses in disguise procured for him the designation of 'the king of the commons.' In 1536 James undertook a voyage to France, and on the 1st of January 1537 he was married to Magdalene, daughter of Francis I., who, however, died in the following July. In June 1538 James married Mary of Guise, widow of the Duke of Longueville and sister of the Duke of Guise.

Meanwhile the principles of the reformed faith were making progress in Scotland, and Henry VIII. tried to induce his nephew to follow his ecclesiastical policy and to repudiate the authority of the papal see. But James, though he looked with a severe eye upon the overgrown wealth, idleness, and corruption of the clergy, found it necessary to rely on their

support in order to reduce the exorbitant power of the nobles. The bishops on their part strove to bring about a rupture with England. With the hope of gaining over his nephew to adopt his policy, Henry invited the Scottish king to meet him at York in the autumn of 1541, and waited there six days for him. But James was induced to break his engagement, and the proud temper of the English monarch fired at the insult. Other causes of offence arose, and war broke out between the two countries in 1542. An army of 30,000 men under the Duke of Norfolk were ordered to invade Scotland; but the attempt ended in nothing. A Scottish army levied to oppose the invaders advanced as far as Fala; the nobles, however, while willing to support James within the kingdom, refused to follow him beyond the frontier. Another army was shortly after levied by the exertions of the clergy; but the command of this army having been unwisely given by the king to a favourite named Oliver Sinclair, the nobles again refused to act. While the Scottish army thus disputed, a body of English Borderers fell upon and completely routed them at Solway Moss, taking many prisoners. James was completely overwhelmed by this shameful discomfiture, and fell into a state of the deepest despondency. He retired to Falkland Palace attacked by a slow fever which no skill could remove, and he died there 14th December 1542, in the thirty-first year of his age. He left one legitimate child, the ill-fated Mary, who was only a few days old at his death, and six natural children, one of whom was the celebrated Regent Moray. See Bapst, *Les Mariages de Jacques V.* (1889).

James I. OF ENGLAND (1603-25) AND **VI. OF SCOTLAND** (1567-1625) was the only son of Mary, Queen of Scots, and Henry, Lord Darnley. He was born in Edinburgh Castle on the 19th June 1566, at which time unpleasant relations between Mary and her husband were beginning to develop themselves. Then followed the murder of Darnley in February 1567, the marriage of Mary to Bothwell in May, the rising of the nobles at Carberry Hill in June, and the subsequent imprisonment of Mary and enforced resignation of her crown. In consequence of this rapid course of events James was proclaimed king of Scotland, 29th July 1567. The nation at this time was rent by factions, and, as was customary in Scotland under 'bairn kings,' each faction sought to have possession of the person of the monarch. James was placed in Stirling Castle in the keeping of the Earl of Mar, and here he received his education under the famous scholar George Buchanan. Within eleven years Moray, Lennox, Mar, and Morton had successively held the regency of the kingdom, and when, in 1578, the Regent Morton was driven from power James himself nominally assumed the direction of affairs. But the government of his advisers was unpopular, and Morton once more succeeded in re-establishing himself in the regency. About this time James began to exhibit that partiality towards favourites which was so characteristic a feature of his life; and an accomplished, but truculent and unprincipled soldier, Captain James Stewart, whom he created Earl of Arran, was the favourite with whose help and that of the Duke of Lennox (another favourite) the king was enabled finally to break the power of Morton. After Morton's execution (1581) James ruled the kingdom through his two favourites, not without much discontent and grumbling on the part both of the kirk and the nobility. Hence, on 12th August 1582, occurred the well-known Raid of Ruthven (q.v.), when the king was forcibly seized by a party of his nobles, and under their direction was obliged to sanction the imprisonment of Arran and the banishment of Lennox. In 1583 a counter-plot

effected the king's freedom, when he immediately restored Arran to power. The confederate lords were obliged to flee to England, whence, in 1585, through the connivance of Queen Elizabeth, they returned, and with an army of 10,000 men forced James to capitulate in Stirling Castle. Arran once more was banished, and never again restored to power.

In 1586 Queen Mary, then a prisoner in England, was condemned by the English court to be executed. James's conduct at this time, taken in connection with his previous attitude towards his mother, and his subsequent friendly alliance with Elizabeth, has been severely censured by Mary's partisans, and in truth does not admit of much defence. In the winter of 1589 he went to Denmark, where he married the Princess Anne (1574-1619), daughter of Frederick II., king of that country. During these and subsequent years James was frequently in conflict with the Presbyterians on the one hand, and with the Roman Catholics on the other. Like Elizabeth, he hated Puritanism, and was not disinclined towards some modified form of Romanism. The spirit of Presbyterianism he regarded as too democratic, and was therefore disposed to introduce Episcopacy into Scotland, and did ultimately (in 1600) succeed in establishing bishops. In consequence of this tendency the king had frequent theological discussions with the Presbyterian ministers; which discussions, however, were not altogether unwelcome to him, as he had a strong taste for polemics. From 1591 to 1594 the Roman Catholic lords in the north were in a state of semi-insurrection; but James finally marched against them, and the disturbances were suppressed. In 1600 occurred that strange episode, the Gowrie Conspiracy (q.v.).

During the whole of Elizabeth's long reign the disturbing element in English politics had been the question of the succession to the throne; this was finally settled when, on the death of that queen in 1603, James VI. of Scotland ascended the English throne. He was at first well received by his subjects in England, but subsequently became unpopular by reason of his continued partiality towards favourites. He also degraded the prerogative of the crown by the sale of titles of dignity: the title of baronet, which he originated, could be bought for £1000, a barony for £5000, and an earldom for £20,000. His chief favourite at this time was Robert Kerr, or Carre, a Scotchman of the Border family of Kerr of Ferniehirst, on whom he showered honours and emoluments, finally creating him Earl of Somerset. When Carre fell out of favour he was succeeded by the notorious Buckingham. The king really governed through these minions, and the name and prestige of England, so formidable under Elizabeth, sank into insignificance. In 1617 James revisited Scotland, signalling his reappearance among his Scottish subjects by several angry disputes with the clergy, in which the king did not always come off victorious. His eldest son, Henry, Prince of Wales, having to the great grief of the nation, died in 1612, the succession devolved upon his second son Charles (afterwards Charles I.), between whom and a Spanish princess the king was long anxious to effect a marriage, but after years of negotiation the project was not successful. Buckingham, who was entrusted too much with the conduct of the affair, acted rashly and unwisely, with the consequence that war broke out between the two countries.

James died on 27th March 1625. His character has been painted in various colours by different historians. Sully epigrammatically described him as 'the wisest fool in Christendom'; and Macaulay, in one of his antithetical sentences, exaggerates this aspect of James's character by stating that 'he was indeed made up of two men—a witty, well-read scholar, who wrote, disputed, and languaged,

and a nervous, drivelling idiot who acted.' By more recent historians, however, such as Von Ranke and Mr S. R. Gardiner, his character has been treated more broadly and mildly; but perhaps the best popular estimate of the man, his manners, and his peculiarities, is the representation of him which is given by Scott in *The Fortunes of Nigel*.

The literary tastes which James had acquired under the tuition of Buchanan appeared in after life in various works which he issued, but none of which ever became popular. These are *Essays of a Prentice in the Divine Art of Poetrie* (1584); *Poetical Exercises at Yvancut Hours* (1591); *Deomologie* (1597); *Basiliæan Diron* (q.v.), in which he embodied his somewhat extreme views as to the divine right of kings; and the *Counterblast to Tobacco* (1616).

Besides the historians already named, as well as Burton, Tytler, Calderwood, &c., the following may be read: Goodman's *Court of James I.*, edited by J. S. Brewer (2 vols. 1839); *The Secret History of the Court of King James I.*, edited by Sir W. Scott (2 vols. 1811), containing Osborne's *Memoirs*, Weldon's valuable *Court of King James*, &c.

James II. of England and VII. of Scotland (1685-88) was the second surviving son of Charles I., and was born 14th October 1633. A short time before his father's execution he escaped to Holland, and shortly after went to France. He served for some time in the French army under Turenne, and when he was obliged to leave the French territory on the conclusion of peace between the English Commonwealth and Louis XIV. he entered the military service of Spain. At the Restoration (1660) James was recognised as Duke of York, and was made Lord High Admiral of England. In November 1659 he had married Anne Hyde, daughter of the Chancellor, afterwards Earl of Clarendon. He had some skill in maritime affairs, and in 1665 he commanded an English squadron which gained a signal victory over a Dutch fleet under Admiral Opdam. In 1671 he again encountered, off the coast of Suffolk, the Dutch led by the celebrated De Ruyter, and the conflict, which was obstinately contested, terminated at nightfall in a drawn battle. On the death of Anne Hyde in 1671 James made a public avowal of his conversion to the Roman Catholic faith. In 1673 the English parliament passed the Test Act, requiring all civil and military officers to subscribe a declaration against transubstantiation, and to receive the sacrament according to the rites of the Church of England. James was consequently obliged to resign the office of Lord High Admiral. Shortly after he married Mary, daughter of the Duke of Modena. The national ferment occasioned by the supposed Popish Plot became so formidable that he was under the necessity of retiring to the Continent, and during his absence an attempt was made to exclude him from the throne. He returned at the close of 1679, but King Charles found it necessary to require him to remove again from the court, and he was sent down to Scotland to take the management of its affairs. The cruelties which he inflicted on the Covenanters have left an indelible stain upon his memory. Meanwhile the Exclusion Bill was again introduced, and was twice passed by the Commons, but in the first instance it was rejected by the Lords, and on the second occasion it was lost by the dissolution of the parliament. James then returned to England, and in direct violation of the law took his seat in the council, and resumed the direction of naval affairs.

At the death of Charles in 1685 James ascended the throne, and on taking his seat at the head of the council board he declared his resolution to maintain the established government both in church and state, and to respect the liberties of the people. But immediately after his accession he proceeded to levy, on his own warrant, without

waiting for the meeting of parliament, the customs and excise duties which they had granted to Charles only for life. He sent a mission to Rome, heard mass ostentatiously in public with regal splendour, became, like his brother, the pensioned slave of the French king, and made the interests of his kingdom subservient to the arbitrary and ambitious designs of that monarch. In Scotland, at his instance, the persecution of the Covenanters was renewed with increased severity and cruelty, and a law was passed enacting that attendance at a conventicle, either as a preacher or a hearer, should be punished with death and confiscation of goods. After the futile rebellion of James's nephew, Monmouth (q.v.), came the 'Bloody Assize,' presided over by the infamous Jeffreys, in which 320 persons were hanged; the judicial murder of Alice Lisle and Elizabeth Gaunt produced an especially strong impression on the public mind. The suspension of the Test Act by the king's own authority, his prosecution of the seven bishops on a charge of seditious libel, his conferring ecclesiastical benefices on Roman Catholics, his violation of the rights of the universities of Oxford and Cambridge, his plan for packing parliament, and numerous other arbitrary and despotic acts showed his fixed determination to destroy the constitution and to overthrow the church. The indignation of the people was at length roused against him, and it became evident that his expulsion from the throne was necessary for the welfare and safety of the nation. The interposition of William, Prince of Orange, James's son-in-law, was formally solicited by seven influential politicians, and was readily granted. He landed at Torbay on the 4th of November 1688 at the head of a powerful army, and began his march towards London. He was everywhere hailed as a deliverer, while James was deserted not only by his ministers and troops, but even by his daughter the Princess Anne. The unfortunate king, on the first appearance of danger, had sent his wife and infant son to France, and he soon after made his escape from the country and joined them at St Germain's. He was hospitably received by Louis XIV., who settled a pension on him. In the following year, aided by a small body of French troops, he proceeded to Ireland and made an intellectual attempt to regain his throne. He was defeated at the battle of the Boyne, and returned to St Germain's, where he resided until his death, 6th September 1701, in the sixty-eighth year of his age. He left two daughters—Mary, married to the Prince of Orange, and Anne, afterwards queen—and one son by his second wife, James Francis Edward, usually designated the Chevalier de St George (see JACOBITES). He had also several illegitimate children—one of whom, Marshal Berwick, was a renowned military commander.

See the histories of England by Macaulay, Ranke, Lingard; Burnet's *History of his Own Time*; Macpherson's *History of Great Britain* (1775) and *Original Papers* (1775); the *Lives* by C. J. Fox and Clarke (1816); Wellwood's *Memoirs*, and Luttrell's *Relation of State Affairs*; Wilson's *James II. and the Duke of Berwick* (1876); Campana de Cavelli, *Les Derniers Stuarts à St Germain* (Paris, 1871); Bloxam's *Magnolia Gallery and James II.* (1886); works cited at CHARLES II.; and articles SEVEN BISHOPS, &c.

James, GEORGE PAYNE RAINSFORD, romance writer, was born in London in 1801. The son of a well-known physician, he was educated at Putney and in France, and by seventeen had written some eastern tales, which found favour with Washington Irving. Thereafter he ceased to write, dictating instead to an amanuensis his 'thickening fancies.' In all he published seventy-seven works, in 198 volumes—historical romances mostly, but also biographies, poems, &c. The best were

among the earliest—*Richelieu* (1829) and *Henry Musterton* (1832). He was British consul at Richmond, Virginia, from 1852 till 1858, and then at Venice till his death there on 9th May 1860. 'G. P. R. James' may be classed as a hybrid—a productive hybrid between Dumas and Mrs Ann Radcliffe. Leigh Hunt writes kindly of him, and Sir Archibald Alison could 'revert with pleasure to his varied compositions,' which even yet may be safely recommended to the 'young person.' But his two horse-men will be remembered best, if not indeed solely, by Thackeray's parody *Barbazure*.

James, SIR HENRY, director of the Geological Survey of Ireland and of the Ordnance Survey of the United Kingdom, was born near St Agnes in Cornwall in 1803. He passed in 1825 from the Royal Military Academy, Woolwich, into the Royal Engineers. In 1844 he was appointed director of the Geological Survey of Ireland; in 1846 head of the Admiralty works at Portsmouth; in 1852 director of the Ordnance Survey of the United Kingdom; and in 1857 chief of the Statistical and Topographical Department of the War Office. He was knighted in 1860, and made major-general in 1868. He died at Southampton on 15th June 1877. From his pen came several works on geology, surveying, &c., including *Ordnance Trigonometrical Survey of Ireland* (1858) and *Account of the Principal Triangulation of the United Kingdom* (1864). By means of zinc-photography, a process which he invented in 1859, he produced fac-similes of *Domesday Book* (32 vols.) and of national MSS. of England (to Anne's reign), of Scotland, and of Ireland.

James, HENRY, LORD (of Hereford), Q.C., born at Hereford in 1828, went to school at Cheltenham College, and was called to the bar of the Middle Temple in 1852. In 1850, and again in 1851, he had attained legal distinction as lecturer's prizeman at the Inner Temple. He became a Queen's Counsel in 1869, a bencher of his Inn in 1870; and in March 1869 entered the House of Commons for Taunton. He continued to represent Taunton in the Liberal interest until 1885, when he was returned for Bury, in Lancashire. He made a considerable mark in the debates on the Judicature Bill in 1872, and in the succeeding year was appointed by Mr Gladstone Solicitor-general. In 1873 he became Attorney-general, and was knighted; and in 1880, on the return of Mr Gladstone to power, he again became Attorney-general. He ably conducted the *Corrupt Practices Bill* through the House of Commons in 1883. Sir Henry James was offered the Lord Chancellorship on the formation of Mr Gladstone's third administration in 1886, but he declined to take office in consequence of his inability to support the Premier's Irish Home-rule policy; and in 1886 he was re-elected for Bury unopposed, as a Liberal Unionist. He defended the *Times* before the Parnell Commission, and strongly opposed the second Home Rule Bill. Created Lord James of Hereford in 1895, he became Chancellor of the Duchy of Lancaster.

James, HENRY, an eminent American novelist, was born in New York, 16th April 1843. He was until his father's death known to the reading public as Henry James, junior, the father (1811-82) being a well-known and original theological writer and lecturer, the exponent in turn of Saude-manianism and the system of Swedenborg. The boy was cosmopolitan from his cradle, and was educated under his father's eye in New York, Geneva, Paris, and Boulogne. In 1862 he entered the Harvard law-school, but his destiny was to be solely a man of letters, and, after the usual preliminaries of magazine-writing and shorter stories, he took his place among contemporary novelists

with *Roderick Hulsan* in 1875. Already in 1869 he had migrated to Europe, there to reside by turns in England and in Italy. He is only less eminent as a critic, and his perfect mastery of modern French literature, added to his natural subtlety of perception, has given a quite extraordinary value to his delightful, clever, yet ineffective studies collected in *French Poets and Novelists* (1878) and *Partial Portraits* (1888). The value of the latter in particular is marred by its inconclusive conclusions, and by too indiscriminate admiration of his friends. His *Hawthorne* (1879), in 'English Men of Letters,' is a clever study, but yet one scarce adequate to its theme. Besides these he has published several volumes of pen-sketches of things in the Old World, written for American magazines, as *Portraits of Places* (1884) and *A Little Tour in France* (1884). His more important novels of greater or less length are *The American* (1878); *The Europeans* (1878); *Daisy Miller* (1878); *A Bundle of Letters* (1879); *Washington Square* (1880); *The Portrait of a Lady* (1881); *The Bostonians* (1886); *Princess Casamassima* (1886); *The Tragic Muse* (1890); *What Maisie Know* (1897); and *The Awkward Age* (1899). Some of his cleverest work is to be found in such volumes of shorter stories as *Stories Revised* (1885), *The Revenger* (1888), *The Aspen Papers* (1888), and *A London Life* (1889).

In fiction James may be said to lead the English section of the analytical school represented in France by Bouquet, Guy de Maupassant, and other too clever young writers. His stories deal mainly with the uneventful lives of Americans living or travelling in Europe, and their main interest lies in the subtle contrasts presented in the contact of a comparatively new with an ancient civilisation. James has paid a price for his citizenship of the older world, and some of his studies have been far from pleasing to his countrymen. His chief want as a novelist is a lack of vigour and of wholesome breadth in his views of life. He shrinks from a strong situation, even when it is required by dramatic necessity, and his constant foible is verbosity, which he escapes only in his shorter stories. His style is ever neat and graceful—a medium admirable for gentle satire on human weakness, unfit for the expression of the tragic and deeper side of nature. A spirit of tranquil pessimism breathes through all his work, but the burden of the world weighs but lightly on his heart.

James, JOHN ANGLI, an eminent Congregationalist minister, was born at Blandford Forum, Dorsetshire, June 6, 1785, apprenticed to a linen-draper, afterwards studied for a short time at a dissenting college at Gosport, and was placed on the 'preaching list' at seventeen. He was highly popular, and when only twenty was settled as pastor of the 'church meeting in Carl's Lane,' Birmingham, where he remained till his death, October 1, 1859. He published a multitude of sermons, tracts, addresses, and small religious volumes (the best known being the *Unquiet Inquirer*), which had a vast circulation (collected, 17 vols., 1860-62). See his *Life* by Dale (1861).

Jameson, ANNA, authoress and art critic, was the daughter of an Irish miniature painter named Browell Murphy, and was born at Dublin in 1794. Her girlhood was passed in the north of England, and then for a dozen years she had been a governess, when in 1823 she married Mr Robert Jameson, a barrister, who in 1829 was appointed a puisne judge in Dominica. In consequence of her husband's harsh treatment, Mrs Jameson refused to accompany him; and save during a brief visit to Canada in 1836-38, she ceased to live with him. Mrs Jameson published in 1831 her first important work, entitled *Memoirs of Female*

Sovereigns, and this was succeeded in the following year by her subtle and fascinating *Characteristics of Shakespeare's Women*. Among other topics upon which she wrote at this time were female labour, penitentiaries, and hospital nursing. She further published, in 1833, *Beauties of the Court of Charles II.*, in 1837 *Sketches of Germany*, in 1838 *Rembles in Canada*, and in 1846 *Memoirs and Essays*. But it is as an art critic that she is best remembered, for her *Handbook to Public Galleries in and near London* (1832); *Lives of Early Italian Painters* (1845); *Poetry of Sacred and Legendary Art* (1848); *Legends of the Monastic Orders* (1850); *Legends of the Madonna* (1852); and a *Commonplace Book of Thoughts, Memories, and Fancies* (1854). Her work on our Lord and John the Baptist as represented in art was completed by Lady Eastlake. She died at Ealing, March 19, 1860. See the *Memoirs* by her niece (1878), and the new edition of her works (6 vols., 1890).

Jameson, LEANDER STARR, leader of the raid into the Transvaal, was born at Edinburgh 8th February 1853, studied medicine there and at London, and having gone to the Cape, settled in medical practice at Kimberley in 1878. Through Mr Rhodes he took part in pioneer work, was made administrator for the South Africa Company at Fort Salisbury, and conciliated enormous influence and popularity. During the troubles at Johannesburg between the Uitlander reform party and the Boer government, Jameson, who by order of Mr Rhodes, then Cape Premier, had concentrated the military forces of Rhodesia at Mafeking on the Transvaal frontier, started with 500 troopers to support the Reformers (29th December 1895) just when they had been intimidated by President Kruger; and after riding foodless for twenty-four hours the party encountered on 1st January 1896 an overwhelming Boer force strongly posted at Krugersdorp, to the west of Johannesburg. Surprised and disappointed that no support came to them from Johannesburg, they fought gallantly till their ammunition was exhausted and till Boer reinforcements brought up artillery. Then Jameson and 450 men surrendered, and were imprisoned at Pretoria, but handed over ere long to the British authorities for trial. Jameson, who arrived in England two months after the raid, was in August condemned to fifteen months' imprisonment, without hard labour, Sir John Willoughby, military chief of the expedition (an officer holding Her Majesty's commission), to ten months, and 'Dr Jim's' other officers to minor terms of imprisonment—all as first-class misdemeanants. The private troopers were not punished. This disastrous raid provoked the German Emperor's congratulatory letter to Kruger, which caused such fierce resentment in Britain and nearly led to war with Germany.

Jameson, ROBERT (1772-1854), geologist, born at Leith, and educated at Edinburgh University and under Werner at Freiberg (1800-2), was elected in 1804 to the chair of Natural History in the university of Edinburgh. At first a Wernerian, he adopted Hutton's views; and he published half a dozen works on mineralogy and geognosy (1804-37).

Jamesone, GEORGE, portrait painter, was born in Aberdeen, probably in 1588, a son of Andrew Jamesone, a master mason and burgess of guild of the city. A baseless tradition affirmed that he studied painting in Antwerp under Rubens along with Van Dyck. Really he was in 1612 apprenticed for eight years to 'John Anderson, painter' (see *Academy*, 14th April 1894). The dates inscribed upon his works prove that in 1620 he practised his art

at Aberdeen, and afterwards mainly in Edinburgh, of which he became a burghess in 1633. He was soon in excellent repute as a portrait-painter, and likenesses by his hand of many of his most eminent contemporaries still exist. One of his chief patrons was Sir Colin Campbell of Glenorchy, for whom he executed an extensive series of portraits, both from the life and from earlier pictures, which are now preserved at Taymouth Castle and Langton House, Duns. Many works attributed to Jamesone—in not a few cases falsely attributed to him—are preserved in the mansions of Scotland. His authentic works are painted with considerable delicacy, but are marred by very pronounced mannerisms, and their painter has little claim to his customary title of 'the Scottish Van Dyck.' He died at Edinburgh in 1644. See J. Bulloch's *George Jamesone* (1885).

James River is formed by the union of the Jackson and Cowpasture streams in the west of Virginia, and has its entire course in that state. It flows in a generally east-south-east direction, passing Lynchburgh and Richmond; and, widening into an estuary for the last 60 miles of its course, it falls into the Atlantic at the southern extremity of Chesapeake Bay. It is 450 miles in length, and is navigable for large steamers to City Point, at the mouth of the Appomattox. It was at Jamestown, now a ruined village on the north bank of this river, that the first English settlement in America was formed (1607). The James River and Kanawha Canal, which extends from Richmond to the White Sulphur Springs, follows the windings of the river for a considerable distance.

James's Bay, the southerly arm of Hudson Bay, about 250 miles long from north to south, and 175 miles wide. It is greatly beset with islands, and its navigation is dangerous.

James's Powder is the modern representative of an old nostrum of Dr Robert James (1703-76) of London. The preparation in the pharmacopœia which is supposed to have similar virtues in febrile affections consists of oxide of antimony and phosphate of lime. It is but little used now.

Jamestown, a village of New York, on Chautauqua Lake, 70 miles S. by W. of Buffalo by rail. It has manufactures of woollens and alpaccas, pianos, furniture, &c. Pop. (1880) 9357; (1890) 16,038.—**JAMESTOWN**, in North Dakota, has a pop. of 2236. See also **JAMES RIVER**.

James Town, the chief place and only seaport of St Helena (q.v.).

Jami, the last classical poet of Persia, 1419-92. See **PERSLA** (*Literature*).

Jamieson, JOHN, D.D., a meritorious Scotch scholar, was born in Glasgow, March 3, 1739, studied for the ministry, and in 1781 was ordained pastor of the Secession (Anti-burgher) congregation at Forfar. In 1797 he was translated to Edinburgh, where he died July 12, 1838. Jamieson's reputation rests on his *Etymological Dictionary of the Scottish Language* (1808-9; supplement 1825; best edition by David Donaldson, 4 vols. 1879-87). It is a work of great industry, and of very considerable value as a collection of Scotch words, phrases, customs, &c.; but it possesses little critical or philological merit, according to the present standard. His preliminary dissertation on the 'Origin of the Scots Language' is an elaborate but unsuccessful attempt to prove that the Scottish language is really the Pictish language, and that the Picts were not Celts, but Scandinavian Goths. Jamieson also wrote on the Cublees, on the affinities of the Greek and Latin languages to the Gothic, on the royal palaces of Scotland, &c.; and he published editions of Barbour's *Brave*, Blind

Harty's *Sir William Wallace*, and Slezar's *Theatrum Scoticum*.

Jammu (*Jummoa*), a town of Cashmere, on an affluent of the Chenab. Pop. 8000.

Jammuotri, hot springs near the source of the Jumna, in northern India, in 30° 59' N. lat. and 78° 35' E. long., 10,849 feet above the sea. Their temperature is 194.7 F., nearly that of boiling water at their elevation. They are overhung by three connected mountains known as the Jammuotri Peaks (20,100 to 21,150 feet).

Janesville, a city of Wisconsin, lies mostly between bluffs in the narrow bottom-land of Rock River, which is crossed here by six bridges, 91 miles NW. of Chicago, at the junction of four railways. The river is crossed by dams, and its water-power is utilised in the numerous manufactories. There are a number of flour, cotton, and woollen mills, two foundries, and thirty-four factories of various kinds. Pop. (1890) 11,836.

Janet, PAUL, an eminent French philosopher, born at Paris, 30th April 1823. He was educated at the Normal School, and was in turn teacher in the gymnasium at Bourges, and professor of Philosophy in the faculty at Strasburg and of Logic in the Lycœum Louis-le-Grand. In 1864 he was elected to the Academy of Moral and Political Sciences, and then he lectured in the Sorbonne at Paris. He died 4th October 1899.

His books are *La Famille* (1855), *Histoire de la Philosophie morale et politique* (1858), *Le Philosophie du Bonheur* (1862), *Le Matérialisme contemporain en Allemagne* (1864), *Le Courant et la Pensée* (1866), *Les Problèmes du XIX^e Siècle* (1872), *Philosophie de la Révolution Française* (1875), *Les Causes nées* (1876; Eng. trans 1878), *La Philosophie Française contemporaine* (1879), and *Les Origines du Socialisme contemporain* (1883).

Janin, JULES GABRIEL, French critic and novelist, was born at St Etienne, December 24, 1804, and had his education there and at Paris. He took early to journalism, writing for the *Figaro*, the *Quotidien*, and the *Journal des Débats*, and his dramatic criticisms in the last-named journal made him a reputation by their wit and vivacity. Janin wrote with fatal fluency, and his numberless articles, prefaces, books of travel, and miscellaneous pieces of task-work pleased his readers and filled his pockets, but did nothing for a future fame. But the 'prince of critics' wrote gaily for the present, lacking the instinct of perpetuity. Yet twice he came near to writing things which the world will not willingly let die. His strange and at least half-serious story *L'Âge mort et la Femme quillatinte* (1829) was followed by *Barnave* (1831), an interesting book, half-historical novel, half polemic against the Orleans family. Janin succeeded to Sainte-Benoît's chair in the French Academy in 1870, and died 19th June 1874. His *Œuvres Choieses*, in twelve volumes, appeared in 1875-78, and his *Correspondance* was published in 1877.

Janina (pronounced *Yanina*), or JOANNINA, capital of a vilayet in Turkish Albania, stands in a striking situation on a lake (12 miles long by 3 broad) of the same name, 50 miles inland from the shore opposite the island of Corfu. Its buildings include more than twenty ecclesiastical edifices, and the ruined castle of Ali Pasha (q.v.), whose headquarters were at Janina. Gold lace is extensively manufactured, as well as morocco leather, silk goods, and coloured linen. The population, which numbered 40,000 under Ali Pasha, is now about 20,000, of whom some 15,000 are Greeks; Greek is the language spoken. The town has been under Turkish rule since 1430.

Janizaries (Turkish, meaning 'new soldiers'), the first regular standing army of the Turks,

formed by Sultan Orkhan, about 1330, of Christian prisoners compelled to embrace Mohammedanism, and of the children of Christians forcibly trained as Mussulmans. It was more perfectly organised by Orkhan's son, Amrath I., after 1362, especial privileges being conferred on those who belonged to it. This soon induced many Turks to join its ranks. There were two classes of Janizaries, one regularly organised, dwelling in barracks in Constantinople and other towns, whose numbers sometimes amounted to 100,000, and the other composing an irregular militia, scattered throughout the empire, and amounting to 300,000 or 400,000. At the head of the whole force was an *aga*, who was held in most reverential respect, and whose power extended to life and death. In time of peace the Janizaries acted as a police force. In war they served on foot, and were noted for the wild impetuosity of their attack. The sultan's bodyguard was formed of them. But success and special privileges produced their usual effects: the history of the Janizaries abounds in conspiracies, assassinations of sultans, viziers, agas, &c., and atrocities of every kind, and in the end they became more dangerous to the sultans than any foreign enemies. More than one sultan attempted, but unsuccessfully, to reform or dissolve them. At last Sultan Mahmoud II., in 1826, having organised a new force after the pattern of the European armies, displayed the flag of the Prophet, and after some sanguinary fighting drove back the Janizaries into their barracks, which he burned, 8000 perishing in the flames. Not fewer than 15,000 were executed, and more than 20,000 banished. By a proclamation of June 17, 1826, the Janizary force was finally dissolved; its place was taken by the Nizam, the modern regulars organised on a European plan.

Jan Mayen Land, a volcanic island in the Arctic Ocean, named after the Dutch navigator by whom it was discovered in 1611. It lies between Iceland and Spitzbergen, and is 35 miles long. Its highest point is the extinct volcano of Beerenberg, 8350 feet (Mohn, 1887), the sides of which are covered with immense glaciers and frozen waterfalls. In 1882-83 it was made the station of the Austrian polar expedition. Important seal and whale fishings are carried on east and north of Jan Mayen every summer. For an account of the island, see Lord Dufferin's *Letters from High Latitudes* (2d ed. 1857), and *Nature* for August 1883.

Jansen, CORNELIUS, from whom the sect of Jansenism derives its name, was born in 1585, at Aequoi, near Leerdam, in Holland. He made his studies at Utrecht, Louvain, and Paris, and from early youth was familiar with some of the disciples of Bajus (q.v.), and with the Abbé de St. Cyran. For some time he filled a chair at Bayonne; and in 1617 he was called to Louvain, where in 1630 he was appointed professor of Theology. In 1636 he was made Bishop of Ypres, and in this city he died of the plague, May 6, 1638, just as he had completed his great work of more than twenty years' preparation, the *Augustinus*, seu *Doctrina S. Aug. de Hum. Natura Sanitate, Egritudine, Medicina, adversus Pelagianos et Massilienses* (4 vols.), which proved the occasion of a great theological controversy. The main object of this work was to prove, by an elaborate analysis of St. Augustine's works, that the teaching of this Father against the Pelagians and semi-Pelagians on Grace, Free-will, and Predestination was directly opposed to the teaching of the modern, and especially of the Jesuit schools, which latter teaching he held to be identical with that of the semi-Pelagians. Jansen repudiated the ordinary Catholic dogma of the freedom of the will, understood to mean the power to choose at the time good or evil (*libertas contrarie*

dictaminis), asserting merely the existence of freedom from external constraint (*libertas a coactione*), not inward necessity. He also refused to admit merely sufficient grace, maintaining that interior grace is irresistible, and that Christ died for all. In the preface Jansen submitted the work to the judgment of the holy see; and on its publication, under the care of Frommond, in 1640, being received with loud clamour, especially by the Jesuits, the *Augustinus* was prohibited by a decree of the Inquisition in 1641; in the following year it was condemned in general terms, as renewing the errors of Bajus, by Urban VIII. in the bull *In Eminentiss.* This bull encountered much opposition in Flanders; and in France the *Augustinus* found many partisans, animated both by doctrinal predilection and antipathy to the alleged laxity of moral teaching in the schools of the Jesuits, with whom the opposition to the *Augustinus* was identified. Most eminent among these were the celebrated scholars and divines who formed the community of Port Royal (q.v.), Arnault, Nicole, Pascal, and others. Nevertheless, the syndic of the Sorbonne extracted from the *Augustinus* seven propositions (subsequently reduced to five) which were definitively condemned as heretical by Innocent X. in 1653. The friends of the *Augustinus*, while they admitted that in point of right the five propositions were justly condemned as heretical, yet denied that in point of fact these propositions were to be found in the *Augustinus*, at least in the sense imputed to them by the bull. Arnault in a celebrated *Lettre* admitted the church's infallibility on the former question, and the duty of entire submission, but held that the latter was a question of historical fact on which the church might err, and that it was sufficient if the faithful received her decision on it with 'respectful silence.' Meantime the controversy had produced one work that holds its immortality as securely as any book in the range of literature, the *Lettres Provinciales* of Pascal. Arnault's distinction between right and fact was at length condemned by the Sorbonne, and himself and sixty other doctors expelled, and in October 1656 a further condemnation of the *Augustinus*, 'in the sense of the author,' was issued by Alexander VII., rigidly enforced in France, and generally accepted; and early in 1669 peace was partially restored by Clement IX.—at least all overt opposition was repressed by the iron rule of Louis XIV.

The more rigid Jansenists, however, and at their head Antoine Arnault, emigrated from France, and formed a kind of community in the Low Countries. The controversy was revived with new acrimony by the dispute on the so-called 'case of conscience,' whether a dying ecclesiastic could lawfully be absolved who was not convinced that the five propositions as condemned by the church were contained in the *Augustinus*; and still more angrily in the person of the celebrated Quesnel, whose *Moral Reflections on the New Testament* was denounced to the pope, Clement XI., as a text-book of undisguised Jansenism. This pope had already in 1705 decided the case of conscience by the bull 'Vineam Domini,' when in 1713 he condemned by the bull 'Unigenitus' as many as 101 propositions extracted from the *Moral Reflections*. After the death of Louis XIV., the regent, the Duke of Orleans, was urged to refer the whole controversy to a national council, and the leaders of the Jansenist party appealed to a general council. The party thus formed, which numbered in 1717 four bishops and many inferior ecclesiastics, were called, from this circumstance, the Appellants. The firmness of the pope, and a change in the policy of the regent, brought them into disfavour. An edict was published, June 4, 1720, receiving the bull; and even the parliament of Paris submitted to register

it, although with a reservation in favour of the liberties of the Gallican Church. The Appellants for the most part submitted, the recusants being visited with severe penalties; and on the coming of age of the new king, Louis XV., the unconditional acceptance of the bull was at length formally accomplished. From this time forward the Appellants were rigorously repressed, and a large number emigrated to the Netherlands, where they formed a community, with Utrecht as a centre. The party still remaining in France persisted in their inveterate opposition to the bull, but the real significance of Jansenism may almost be said to have died with Quesnel in 1719, and, indeed, the movement inaugurated by such intellects as Arnault and Pascal ended in France before the middle of the century in fanaticism and superstition. The miracles in the St Médard cemetery, and the physical convulsions that became common, brought Jansenism in France to a discredited conclusion (see CONVULSIONARIES).

In one locality alone, Utrecht, and its dependent churches, can the sect be said to have had a regular and permanent organisation. The vicar-apostolic, Peter Kodde, having been suspended for Jansenist sympathies by Clement XI. in 1702, the chapter of Utrecht refused to acknowledge the new vicar named in his place, and angrily joined themselves to the Appellant party in France, many of whom had found a refuge in Utrecht. At length, in 1723, they elected an archbishop, Cornelius Steenhoven, for whom the form of episcopal consecration was obtained from the French bishop Varlet (titular of Babylon), who had been suspended for Jansenist opinions. A later Jansenist Archbishop of Utrecht, Meindarts, established Haarlem and Deventer as his suffragan sees; and in 1763 a synod was held, which sent its acts to Rome, in recognition of the primacy of that see. Since that time the formal succession has been maintained, each bishop, on being appointed, notifying his election to the pope, and craving confirmation. The popes, however, have uniformly rejected all advances, except on the condition of the acceptance of the bull *Unigenitus*; and the definition as of Catholic faith of the dogma of the Immaculate Conception of the Blessed Virgin Mary (1854) and the Papal Infallibility (1870) have been the occasion of fresh protests. The Jansenists of the Utrecht Church still number about 6000 souls, and are divided over twenty-five parishes in the dioceses of Utrecht and Haarlem. Their clergy are about thirty in number, with a seminary at Amersfoort. Loos, the Jansenist Archbishop of Utrecht, consecrated Dr Reinkens bishop for the German Old Catholics, Pius IX. restored the Dutch hierarchy in 1851, so that there is now an orthodox Archbishop of Utrecht. The Dutch Jansenists are in doctrine and discipline strictly orthodox Roman Catholics, being known by their countrymen as *Oude Roomsche* ('Old Roman').

See vol. ii. of Hergenrother's *Allgemeine Kirchengeschichte* (1877-78); Fuzet, *Les Jansénistes* (1877); Neale, *Jansenist Church of Holland* (1858); Reuchlin, *Gesch. von Port-Royal* (1839-44); Sainte-Beuve, *Port-Royal* (1860); a German work by Nippold (1872); Séché, *Les derniers Jansénistes* (1891); *French Jansenists*, by Mrs Tollenmache (1893).

Janssen, CORNELIS, born in London in 1593, died at Amsterdam about 1661, lived and worked in England from about 1618 to 1643, and acquired a reputation as a fine painter of portraits and historical subjects.

Jaussens, ABRAHAM, a Dutch painter, who called himself Jaussens van Nuyssen, was born in Antwerp about 1575, and entered the guild of St Luke in 1601. He died at Antwerp in 1632. His most famous pictures are the 'Entombment of Christ' and the 'Adoration of the Magi.' From

his vigorous drawing and admirable colouring he ranks next to Rubens among the historical painters of the period.—Another artist of this name was VICTOR HONORIUS JANSSENS (born at Brussels 1664, died there 1739), who painted chiefly in Rome and at Brussels.

Janthina. See IANTHINA.

Jannarius, ST. or SAN GENNAIO, a martyr of the Christian faith under Diocletian, was a native of Benevento, or at least became bishop of that see in the later part of the 3d century. According to the Neapolitan tradition, he was taken prisoner at Nola; and the place of his martyrdom, in 305, was Pozzuoli, where many Christians suffered the same fate. His body is preserved at Naples, in the crypt of the cathedral, and in a chapel of the same church are also preserved the head of the martyr, and two phials (*ampullæ*) supposed to contain his blood. On three festivals each year—the chief of which is the day of the martyrdom, September 19, the others the first Sunday evening in May and the 16th December—as well as on occasions of public danger or calamity, as earthquakes or eruptions, the head and the phials of the blood are carried in solemn procession to the high-altar of the cathedral, or of the church of St Clare, where, after prayer of longer or shorter duration, the blood, on the phials being brought into contact with the head, is believed to liquefy, and in this condition is presented for the veneration of the people, or for the conviction of the doubter. It occasionally happens that a considerable time elapses before the liquefaction takes place, and sometimes it altogether fails. The latter is regarded as an omen of the worst import; and on those occasions when the miracle is delayed beyond the ordinary time the alarm and excitement of the congregation rise to the highest pitch. Those who are curious as to the literature of the controversy regarding this celebrated legend will find many documents in the sixth volume of the *Hollandist Acta Sanctorum* for September. For a good account of the modern ceremony, see E. N. Rolfe and H. Ingley's *Naples in 1888*.

January, the first month of the year. It was, among the Romans, held sacred to Janus (q.v.), from whom it derived its name, and was added to the calendar along with February by Numa. It was not till the 18th century that January was universally adopted by European nations as the first month of the year, although the Romans considered it as such as far back as 251 B.C.

Janus, an ancient Italian god. The distinctive mark of Roman religion and Roman gods as opposed to Greek gods is that the former are abstract, whilst Greek thought was marked by its anthropomorphism. In the belief of the Roman everything and every action had its corresponding spirit—even such processes as plunging, harrowing, &c. Janus, tried by this test, approves himself as peculiarly Italian. He is 'the spirit of opening,' and there is nothing in the mythology of any other Aryan nation to correspond to him. His name is derived from the same root as the Latin word *janua*, 'a gate' or 'opening.' As the spirit of opening he was invoked at the beginning of all undertakings (at the beginning of human life as *Conscious*). For the same reason he was the god of the beginning of day, *Matutinus Pater*, and of the beginning of the (agricultural) year, the first month of which, January (though originally the eleventh of the calendar year), was dedicated to him. Hence, too, may be explained the fact that he took precedence of all other gods, even of Jupiter, and that he is called in the Salaric Hymn *Deorum Deus* (Macrobi, *Sat.* i. 9), and even

Summarius. In the next place, as the spirit of openings, Janus was the god under whose care were all *januae*, or gates, in Rome; above all, he it was under whose protection was the arch-way out of which the army marched to war and by which it returned. This arch-way, which in later times was replaced by a temple of Janus, naturally had its gates open in time of war and closed in time of peace. The tutelary god of the gate that opened both ways was, by a natural transference of thought, himself represented by an image having a double head that looked both ways (see AS). His connection with the year was sometimes indicated by the fact that three fingers of the right hand were bent so as to indicate the numeral CC (200), while the fingers of the left hand were spread so as to denote the numerals L (50) + V (5), or in later times L + V - V + V—that is, in all, the 355 days of the older, and the 365 days of the reformed Julian year. As the god of gates he naturally carries keys. As an auspicious god he is crowned with laurel. The interpretation of Janus as originally a god of light fails to explain his functions, is at variance with the spirit of Roman religion, and is based on a false etymology: Janus cannot be the masculine of Diana, because the *i* is long (and therefore cannot be consonantal); and, moreover, the real masculine of Diana is preserved in an inscription (C. I. L. 5, 783), *Jovi Dianæ*. Janus is not derived from a root meaning 'to shine,' but from one meaning 'to go.'

Japan. a corruption of Marco Polo's *Zipangu*, itself a corruption of the Chinese pronunciation of the native name *Nihon*. *Nihon*, or *Nippon*, means 'Land of the Rising Sun.' *Dai*, 'Great,' is sometimes prefixed. Japan Proper comprehends four large islands—viz. Honshū (the Japanese mainland), Shikoku, Kyūshū, and Yezo—and extends from 26° 59' to 45° 30' N. lat. Formerly the southern portion of Saghalien belonged to Japan, but this was ceded to Russia in 1875, certain of the Kurile island group being granted in return. The empire of Japan—the area of which has been estimated at 155,000 sq. m., or 34,000 miles larger than the United Kingdom—includes, in addition to the above, nearly 4000 small islands, among which are the Liu Kiu ('Loo Choo') and Kurile groups, and is situated between 24° 6' 50' 56' N. lat., and 122° 45'–156° 32' E. long. It is bounded on the N. by the Sea of Okhotsk, on the E. by the North Pacific Ocean, on the S. by the eastern Sea of China, and on the W. by the Sea of Japan. On the 1st January 1891 the population of Japan was 40,453,461, an increase of nearly 2 millions in 5 years; in 1894 it was 41,390,000. The population is distributed as follows: Honshū, 31,722,674; Shikoku, 2,907,280; Kyūshū, 6,379,262; Yezo, 379,097. Formosa and the Pescadores, ceded by China in 1895, are now Japanese.

Physical Features.—The islands of Japan appear to be the highest portions of a huge chain of mountains which rises from a deep ocean bed: they are the advanced frontier of the Asiatic continent. This chain, though dotted with volcanoes, is not therefore itself of volcanic origin. Earthquakes occur very frequently in Japan, although the western slope, facing the Asiatic continent, is exempt. Japan is one of the most mountainous countries in the world. Its plains and valleys, with their foliage surpassing in richness that of any other extra-tropical region, its arealian hillslopes and forest-clad heights, its alpine peaks towering in weird grandeur above ravines noisy with waterfalls, its lines of foam-fringed headlands, with a thousand other charms, give it a claim to be considered one of the fairest portions of the earth. The sublime cone of the sacred Fuji-san (Fujiyama, Aino, 'Fire-goddess Mountain'), an extinct or rather

dormant volcano, rises from the sea to a height of 12,365 feet. Ontakō-san and Yari-ga-take (each 10,000 feet), Tatē-yama (9500), Yatsuga-dake (9000), Haku-san (8590), Asama-yama (active volcano, 8260), with many other scarcely lower peaks, rise in Honshū. The eruption on July 15, 1888, of Bandaisan (6037 feet), near Lake Inawashiro, was due to imprisoned steam: 1600 feet was blown off the top of the hill, and 27 sq. m. of country covered with debris. The three other large islands also abound in mountains, though of less elevation. Yezo has no fewer than eight active volcanoes. Throughout the empire there are many solfataras, and sulphurous springs well up from hundreds of volcanic valleys. The plains, most of the valleys, and many of the lower hills are highly cultivated. Lakes are not very numerous, the only two of any size being Biwa, near Kyoto, and Inawashiro, midway between Tōkyō and Sendai; but there are countless rivers, most of which, however, are too impetuous to admit of navigation. The harbours are spacious and deep, but not numerous, considering the great length of the coast-line.

Climate.—The different parts of Japan vary widely in climatic conditions. Leaving out the northern and southern extremes, at Tōkyō (Yedo) we find the annual average temperature to be 57·7° F., while in winter the mercury occasionally falls to 16·2, and in summer it may rise to 96; at Nagasaki the lowest winter temperature is 23·2°; at Hakodate the annual extremes are 2 and 84°. The normal hot weather begins only about the beginning of July, and terminates usually in the middle of September. The late autumn is the driest and most agreeable season. The ocean current known as the Kuro-shiwo ('Black Stream') considerably modifies the climate of the south-east coast: thus, while snow seldom lies more than 5 inches deep at Tōkyō, in the upper valleys of Kaga, near the west coast, less than 1° farther north, 18 and 20 feet are common. The east coast of Yezo is visited by a cold current from the Kuriles, which renders the climate foggy in summer and retards cultivation. The rainfall, which varies much in different years, is on an average 145 inches. No month passes without rain: but it is most plentiful in summer, especially at the beginning and the close of the hot seasons, when inundations frequently occur. North and west winds prevail in winter, and south and east in summer. The violent circular storms called typhoons are liable to occur during summer, but are more destructive in the autumn. August and October are the pleasantest months for travelling. Thunder-storms are neither common nor violent, and autumn fogs are equally rare. The climate, though somewhat relaxing to Europeans and having a tendency to produce anaemia and troubles of the head, is fairly salubrious, highly so in the mountains.

Vegetable Productions.—In Hodgson's *Japan* will be found a systematic catalogue of Japanese flora by Sir Joseph Hooker. Chestnut, oak (both deciduous and evergreen), pine, beech, elm, cherry, dwarf-oak, elder, sycamore, maple, cypress, and many other trees of familiar name abound. The grandest forests of pine and oaks of great size grow in Yezo; but the *Rhus vernicifera* or lacquer-tree, the *Laurus camphora* or camphor-tree, the *Broussonetia papyrifera* or paper-mulberry (the bark and young twigs of which are manufactured by the Japanese into paper) and the *Rhus saccharina* or vegetable wax tree of Japan, are among the remarkable and characteristic trees of the country. Bamboos, palms, including sagopalm, and 150 species of evergreen trees likewise flourish. Thus the vegetation of the tropics is strangely intermingled with that of the temperate

or frigid zone; the tree-fern, bamboo, banana, and palm grow side by side with the pine, the oak, and the beech, and conifers in great variety. The camellia, the Paulownia, and the chrysanthemum are conspicuous amongst the indigenous plants. The azalea blooms in May, and a red variety is found in the mountains as late as the beginning of July. The splendid *Lilium auratum* covers the hillsides in July; and these are also bright during the same month with the pink berries of the *Coccoloba japonica*, the same plant from which comes the arrow poison of the New Zealanders. Nymphæas and parnassia fill the lakes and morasses. The tobacco-plant, the tea-shrub, different varieties of the potato, rice, wheat, barley, buckwheat, and maize are all cultivated. The flora of Japan bears a remarkable resemblance to the flora of that part of the North American continent lying between the Lower Mississippi and the Atlantic.

Zoology.—Wild animals are not numerous in Japan. No true wolf exists, the Japanese *yumainu* (wild

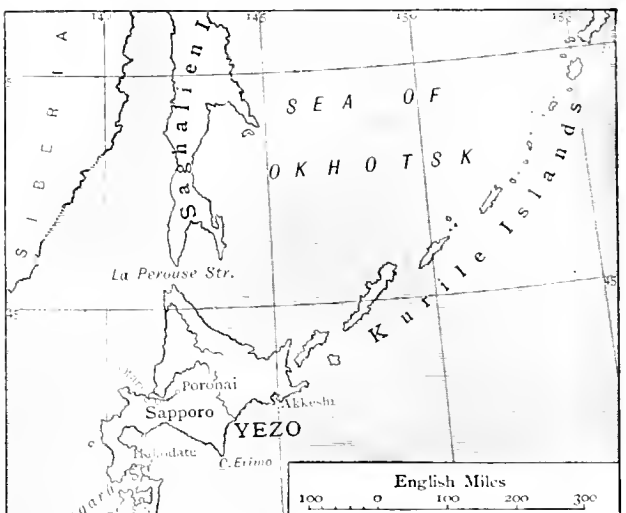

few merits, and in most provinces is a miserable animal. The province of Shimosa, east of the capital, is now largely devoted to horse-breeding, stallions having been brought from San Francisco for the purpose of improving the breed. Draught oxen are common on the main island, but milk-cows are of quite recent introduction. Donkeys are seldom or never seen. Pork is rapidly becoming a favourite food, and horseflesh is prepared at some of the restaurants of the capital. Goats are practically unknown, and the sheep does not thrive. The domestic dog is a wolf-like, ill-conditioned animal, while the domestic cat is remarkable in having a mere stump of a tail; foreign varieties of these animals are being rapidly introduced. There are numerous water-birds—cranes, storks, herons, coots, moorhens, snipe, wild geese, ducks; and cormorants trained to fish, the

dog) being a poor imitation of the fierce European animal. The black bear peculiar to the country is found in the mountains north of Tokyo, and is dreaded in Yezo. Wild boar's flesh is often seen for sale in the capital, as also monkey's flesh, an animal remarkable in Japan for its bright crimson face. Wild deer, protected by law in one or two places, are freely hunted elsewhere. A factory for tinning venison was established in Yezo, at Bibi. A clumsy species of antelope inhabits the mountains. The fox, a small-sized breed, plays an important part in the folklore, as the embodiment of craft and as a kind of magician. A variety of the stoat, known as the *tachi*, wages war on rats and on poultry. A badger resembling the American species is trained for fortune-telling. There are two species of squirrel, also two flying squirrels, various kinds of rat—powerful pests—but no true house mice. The hare is a small species resembling a rabbit. There is a single species of otter, and there are several varieties of the seal and the whale. Of the various varieties of snake only one, the small *ayumushi*, is poisonous. Of domestic animals there are few. The native horse, introduced according to tradition in the 3d century, is really a mere pony, and has

practice dating back at least 1100 years. Land-birds are less numerous, the voracious and powerful crow, sometimes mistaken for a raven, reigning supreme, and acting as a general scavenger. There are two magnificent species of pheasant, pigeons, quail, hazel grouse, and ptarmigan. The goshawk was much used for hawking in feudal times. Various owls abound. Song-birds are not specially numerous, the bullfinch and two varieties of *uguisu* ('Japan nightingale') being best known. Swallows, swifts, sparrows, goat-suckers, and woodpeckers all abound, and there is a fine species of Japanese jay. Of all Japanese birds the *Icteria princeps*, a fly-catcher, is the most beautiful. Bird-catching is commonly practised, decoy-birds being cruelly blinded for the purpose; and the European market is now largely supplied with skins from Japan. One lark is found, besides twelve buntings, eleven thrushes, three robins, a wren, a tit, and various other small birds. There are many varieties of the ordinary fowl, these birds being kept in nearly every house, almost solely for their eggs. The larger breeds known as *Shamo* and *Kukin* are, as their names imply, of foreign origin, the ordinary breed resembling a pheasant in size and shape. The fresh water fish of Japan are

mostly of European genera. The rivers of *Yezo* swarm with salmon, which, when salted, supply the southern market. Carp are kept in garden ponds, and goldfish are reared extensively. Of salt-water fish the red-fleshed *muyuro* and the *tai* are eaten raw under the name of *sashimi*. Oysters abound, Akkeshi in *Yezo* being noted for its beds; the lobster, an emblem of longevity, is highly prized for the table. Insect life is specially abundant; butterflies, moths, dragon-flies, and beetles exist in a astonishing variety. And yet Japan is comparatively free from insect pests. Mosquitoes and gnats are troublesome; wasps are rare; honey-bees are scarce, and the native honey is an insipid substance.

Agriculture is the chief occupation of the Japanese, and they are very careful farmers, thoroughly understanding cropping and the rotation of crops. The soil is not naturally very fertile, being mostly volcanic or derived from igneous rocks, but it is made productive by careful manuring, especially with night-soil from the villages and towns. Rice is the staple production, while barley, wheat, millet, buckwheat, maize, and many varieties of bean and pea are also everywhere produced. The rice harvest commences in September; wheat is sown in drills in November and December, and is reaped in May and June. Of vegetables the staple is the large white radish or *daitkon*. Of Japanese fruits the persimmon and orange are alone worthy to be classed as really good fruits. The plums, peaches, and cherries are very poor, the trees being reared for their blossoms. The culture of tea, introduced from China in 770, is universal in the middle and south; the whole production amounts to about 22,000,000 lb. annually. Sericulture is on the increase, and cotton and hemp are also widely grown. Of sugar a total of over 90,000,000 lb. was produced in 1895; much tobacco is also raised—an inferior kind, remarkable for its mildness and dryness. There are two agricultural colleges, with foreign professors on their staffs, one in Tokyo, the other at Sapporo in *Yezo*.

Mineralogy.—The mineral resources of Japan are considerable, and the government during the sixteen years preceding 1884 spent largely upon mining. Since then it has allowed private enterprise to step in. Gold, silver, copper, iron, lead, antimony, tin, sulphur, coal, basalt, felspar, greenstones, granites (red and gray), rock-crystal, agate, carnelian, amber, scoria and pumice-stone, talc, alum, &c. are found in greater or less quantities. Gold is principally worked in the island of Sado; silver on the main island. Coal-beds extend from Nagasaki to *Yezo*, the principal mines being Takashima, Miike, and Karatsu in Kyūshū, and Poronai, near Sapporo, in *Yezo*. Petroleum is found in small quantities near Niigata and in *Yezo*. The supply of sulphur is almost inexhaustible, and of wonderful purity. Good building-stone is scarce.

History.—The reputed founder of the present dynasty was Jimmu Tenno, who ascended the throne in 660 B.C. The legendary epoch continues for more than 1000 years, and all Japanese history before 500 A.D. is to be classed as legendary. In 201 A.D. the Empress Jingō is said to have invaded and conquered Corea, and this expedition was followed by the introduction of Corean civilisation, the sacred Chinese books *Rougo* and *Sanjimon* arriving from Corea in 285. In 552 Buddhism was introduced from Corea, and became, forty years later, the established religion. In 624 a Buddhist hierarchy was established by government. Shortly before this direct relations had been entered upon with China, and Chinese civilisation was thereafter rapidly assimilated. The system of periods com-

menced in 646, and from this time onward the national history is clearly traced. During the five centuries which ensue the people made immense strides in civilisation. A complete system of officialdom was organised, under the rule of the Fujiwara family, whose members filled all the chief posts under government, and gave a succession of consorts to the imperial house.

The decadence of this family and the growing weakness of the government favoured the rise of the hitherto subordinate military class, which, in the person of Yoritomo, created *Shōgun* or Generalissimo in 1192, seized the reins of power. The usurpation of supreme authority by this officer, long known to Europe by the Chinese name of *Tycoon*, led to the erroneous but natural belief that, down to 1868, there were two emperors in Japan—one, a Mikado or 'spiritual emperor' who reigned but did not govern, and the Shōgun, who really governed though he paid homage to the Mikado. The next four centuries until 1603 were a period of bloodshed, marked by all the untold miseries of civil strife. The military fiefs organised by Yoritomo raised up a feudal baronage, who succeeded in making themselves virtually independent of the central power. Even the Buddhist monasteries in many cases became military centres. At one time (1333-92) two puppet dynasties held sway, the north and the south, to one or other of which the feudal barons rallied. The Shōgunate, made powerful by Yoritomo, itself fell into abeyance, but the military genius and astute policy of Hideyoshi, who died in 1598, prepared the way for its revival in 1603 by Tokugawa Iyeyasu, the illustrious general and statesman who gave a lasting peace to Japan. In 1592 Hideyoshi had directed an expedition against Corea, inflicting a blow on the prosperity of that country from which it has not since recovered. Iyeyasu, victorious over a combination of southern barons at Sekigahara near Lake Biwa in 1600, fixed his seat of government at Yedo, the 'port' situated at the head of the Gulf of Yedo, and near the embouchure of the rivers which drain the largest plain in Japan. Backed principally by the northern clans, he was able to consolidate his power and to found a permanent succession, his descendants reigning at Yedo till 1868. From being a collection of small scattered villages this place soon became one of the most populous cities in the world. His system was perfected by Iyemitsu, the third Shōgun of the Tokugawa dynasty.

It was his policy 'to preserve unchanged the condition of the native intelligence,' and 'to prevent the introduction of new ideas;' and to effect this he not only banished foreigners, interdicted all intercourse with them, and extirpated Christianity, but introduced that 'most rigid and cunningly-devised system of espionage' which was in full activity at the time of the Earl of Elgin's mission, as amusingly described by Laurence Oliphant. 'This espionage,' says a recent Japanese writer, 'held every one in the community in dread and suspicion; not only the most powerful daimyo felt its insidious influence, but the meanest retainer was subject to its sway; and the ignoble quality of deception, developing rapidly to a large extent, became at this time a national characteristic. The daimyos, who at first enjoyed an honourable position as guests at the court of Yedo, were reduced to vassalage, and their families retained as hostages for the rendition of a biennial ceremonial of homage to the Shōgun. Restrictions surrounded personages of this rank until, without special permission, they were not allowed to meet each other alone.' The Portuguese, who first landed in Japan in the year 1543, carried on a lucrative trade; but by and by the ruling powers took alarm, ordered away

all foreigners, and interdicted Christianity (1624), believing that foreigners impoverished the country, while their religion struck at the root of the political and religious systems of Japan. The converts to Catholicism were found to have pledged their allegiance to a foreign power, while their conduct is said to have been offensive towards the Shintō and Buddhist temples; so that in time they came to be regarded as a dangerous and anti-national class whose extirpation was essential to the well-being of the nation and to the success of the political system being organised or perfected by Iyemitsu. The Portuguese continued to frequent Japan till 1638, when they and their religion were finally expelled. From this date the Japanese government maintained the most rigid policy of isolation. No foreign vessels might touch at Japanese ports under any pretence. Japanese sailors wrecked on any foreign shore were with difficulty permitted to return home; while the Dutch, locked up in their factory at Deshima, were allowed to hold no communication with the mainland; and the people lived 'like frogs in a well,' as the Japanese proverb has it, till 1853, when they were rudely awakened from their dream of peace and security by Commodore Perry steaming into the harbour of Uraga with a squadron of United States war-vessels. He extorted a treaty from the frightened Shōgun, 31st March 1854, and Japan, after a withdrawal of 216 years, entered once more the family of nations. Other countries slowly followed the example of the United States until sixteen in all had obtained the same privileges.

Five ports, Kanagawa (Yokohama), Kōbe (Hyōgo), Nagasaki, Niigata, and Hakodate, were opened to foreign commerce, 'settlements' or foreign quarters in these being set apart for the residence of foreigners under the jurisdiction of their own consuls. A limit of travel, extending to a radius of twenty-five miles round these ports, was granted. Foreign settlements were also established in Yedo (Tokyo) and Osaka, these settlements being within the prescribed twenty-five miles' limit of Yokohama and Kōbe. Obstructions being placed in the way of foreign merchants settling at Kanagawa, the question was quickly solved by their crossing the narrow bay, now filled up, and erecting their 'hongs' at Yokohama, a few miles farther from the capital. With the opening of these ports commenced the extra-territoriality system under which Japan has shown herself so restive.

The fall of feudalism was merely accelerated by the arrival of foreigners. For long not a few of the most powerful clans, chiefly Satsuma and Chōshū, had been dissatisfied with the Shōgun's position, and these gladly availed themselves of the pretext now furnished for opposing him. All possible means were taken to involve him in complications with the ambassadors at his court; and to this motive rather than to any hatred of foreigners are to be ascribed the numerous assassinations which darkened the period immediately prior to 1868. Every weakening of his power was a step gained towards his overthrow and the longed-for unification of the empire in the hands of the Mikado (emperor). At length the Shōgun resigned; but it was only after a sharp civil war in the winter of 1867-68 that the power of his adherents was completely crushed. At the outset of the struggle the imperial party were decidedly retrogressive in their political ideas; but before its close various circumstances convinced them that without intercourse with foreign nations the greatness which they desired for their country could not be achieved; and when they got into power they astonished the world by the thorough-

ness with which they broke loose from the old traditions and entered on a course of enlightened reformation. Recognising Yedo as really the centre of the nation's life, they resolved to make it the capital; but the name Yedo being distasteful through its associations with the Shōgunate, they renamed the city Tokyō or Tokkei—i.e. 'eastern capital.' Here the emperor established his court, abandoning for ever that life of seclusion which had surrounded his ancestors with a halo of semi-divinity, but deprived them of all real power. The venerable city of Kyōto, which had remained the capital since 794, was at the same time renamed Saikyō or Saikēi—i.e. 'western capital.' The daimyos, very few of whom were more than mere weaklings under the direction of strong-willed retainers, resigned their fiefs, and were pensioned by the government. Since 1868 the leading men of Satsuma and Chōshū, forming what is called the Sat-chō combination, have held the important portfolios of state. The new period, commencing with the Emperor Mutsuhito's accession, has been named *Meiji*, 'enlightened peace.'

Japan has during the Meiji period striven to make her influence felt as a powerful factor in Asiatic politics. Her expedition to Formosa in 1874 to punish piracy, her annexation in 1879 of the Loo Choo Islands, notwithstanding China's remonstrances and threats, her spirited policy in Corea in 1873 and again in 1882, her conscription law of 1883 and subsequent army reorganisation, her development of a strong navy, her coast-defence scheme of 1887, subscribed to liberally by wealthy private individuals, prove her assertive spirit. A rebellion in 1877 of the fiercer Satsuma men under General Saigō was promptly crushed.

In 1887 the negotiations for a revision of the treaties were broken off, owing to an outbreak of popular dissatisfaction with the guarantees demanded by the seventeen foreign powers acting in concert. This breakdown was followed by a distinct conservative reaction in the nation, in no way seriously affecting the steady progress of western institutions, but marking a more cautious attitude and a more critical spirit. In the spring of 1889 the combination of treaty powers was broken through by the action first of the United States and then of Germany and Russia, who formed treaties on their own account, abolishing extra-territoriality and sanctioning mixed residence under certain mild restrictions. These treaties were to come into force in 1890. Mexico, not a treaty power, had also arranged an independent treaty in November 1888. Other powers prepared to follow. But a strong opposition having sprung up, the Kuroda cabinet found itself unable to carry out the scheme, and treaty revision was once more shelved. This is the close of the first epoch in the modern history of Japan, following on the heels of the promulgation of a popular constitution, February 11, 1889.

The position in which Japan has been placed during the past few decades is so exceptional that outsiders find great difficulty in forming a correct judgment of her political situation. Instability is supposed where it is really absent, the fact being that no nation's history has been more consistent than Japan's. The sudden change of front in 1868 was deliberate and final, one end having been kept in view all through the independence and glory of Dai Nippon. So hurried an assimilation as was made necessary by her complete previous isolation was naturally accompanied by numerous minor imprudences and extravagances, the result of ignorance. But the thoroughly patriotic spirit of the nation has triumphed, and her administration is now in a highly satisfactory condition.

The assassination in 1877 of Ōkubo, chief of the party whose reforms gave rise to the Satsuma rebellion, was followed twelve years later by the assassination of Viscount Mori, a cabinet minister. This last was not, like the former, a political event, but merely an unfortunate isolated incident, the work of a religious fanatic, a Shintoist. Political assassination is not, however, dead, and is a peculiar danger in Japan, where its perpetrators seem wholly regardless of their own lives.

During the past few years, especially since the reconstruction of the cabinet and the administration in 1886, the court has emerged entirely from its seclusion. The emperor and empress have visited all the chief institutions, and are present at public spectacles. The crown-prince, Haru, was the first in the long dynasty to be educated at a public school. A new nobility was created in 1884, drawn partly from the old feudal baronage and partly from the new men of 1868. It consists of five orders, princes or dukes (11), marquises (28), counts (85), viscounts (355), and barons (102), who send representatives to the newly-created Upper Chamber. The nation is itself divided into three classes, *Kwazoku* ('nobility'), *Shizoku* ('gentry'), and *Heimin* ('commonalty'). Officials are of four classes, *shimin*, *chokumin*, *sonin*, and *hannin*. Officials constitute the flower of the nation; class jealousy is absent, careers being open to the poorest. The main events of the triumphant war with China in 1894-95, the acquisition of Formosa, as also the Chinese campaign of 1900, have been noted at CHINA, Vol. III. p. 194. Japan was visited by a terrible earthquake in 1892; and in June 1896 an earthquake wave cost 10,000 lives.

Inhabitants.—With the exception of the wilds of Yezo, peopled by 12,000 Ainos, the Japanese islands are inhabited by a single race speaking various dialects of the same tongue. Probably, but this is merely a conjecture, the Japanese are a mixed race, the issue of the intermarriage of victorious Tartar settlers, who entered Japan from the Korean peninsula, with Malays in the south and people of the Aino race in the main island. We read in Japanese annals of constant war with savages, and in comparatively recent times the Aino race occupied the northern extremity of Honshū. There are two distinct types of Japanese face, that which is found in art designs being the aristocratic and rarer type. It is distinguished by an oval head and face, rounded frontal bones, a high forehead, a nose curved and well shaped but not prominent, narrow and lightly oblique eyes with an overlapping of the eyelid. In the man the face is almost hairless, with the exception of a narrow and short moustache. The complexion is pallid or slightly olive, and the expression demure. The commoner and vulgar type, almost universal in the northern districts, is pudding-faced, full-eyed, flat-nosed, and good-humoured in expression. The stature of the race is small, and the trunk is proportionately long as compared with the legs, which are short. The use of heavy wooden clogs (*gata*), together with the carrying, when still young themselves, of their infant brothers and sisters, gives the women excessively thick ankles and flat feet. The hands are usually prettily shaped, both in the man and the woman; but the habit of keeping these, especially in winter, inside the

kimono ('coat'), while the wide sleeves are allowed to hang loose, makes them clumsy to the touch. The hair is coal-black and strong in texture, and the beard has sometimes a ruddy tinge. The race is physically an inferior one, the men having an ill-developed form and harsh features, whilst the women lose any pretensions to good looks after the first bloom of youth is over. The plainness of the latter is increased by the habit at marriage, or after passing the marriageable age, of blackening the teeth and shaving the eyebrows, customs happily on the wane. The girls, with their rosy cheeks, fascinating manners, and exquisitely tasteful dress, are, however, particularly attractive, and the children are bright and comely, being allowed full liberty to enjoy themselves—indeed Japan is the paradise of children.

The Japanese have many excellent qualities: they are kindly, courteous, law-abiding, cleanly in their habits, frugal, and possessed with a high sense of personal honour which makes sordidness unknown. This is associated, moreover, with an ardent patriotic spirit, quite removed from factionness. Nowhere are good manners and artistic culture so widespread, reaching even to the lowest. On the other hand, the people are deficient in moral earnestness and courage, which leads to corruption in social life and institutions. It is only when matters have become intolerable that discipline is enforced by the use of Draconian measures. An utter lack of chivalry towards women is an unpleasant feature of the national life. Civic courage has also to be developed.

The town costume of the Japanese gentleman consists of a loose silk robe extending from the neck to the ankles, but gathered in at the waist, round which is fastened a girdle of brocaded silk. Over this is worn a loose, wide-sleeved jacket, decorated with the wearer's armorial device. White cotton socks, cleft at the great toes, and wooden pattens complete the attire. European costume has been prescribed by government as the official dress, and the empress and her suite have recently adopted foreign costume, being followed to a certain

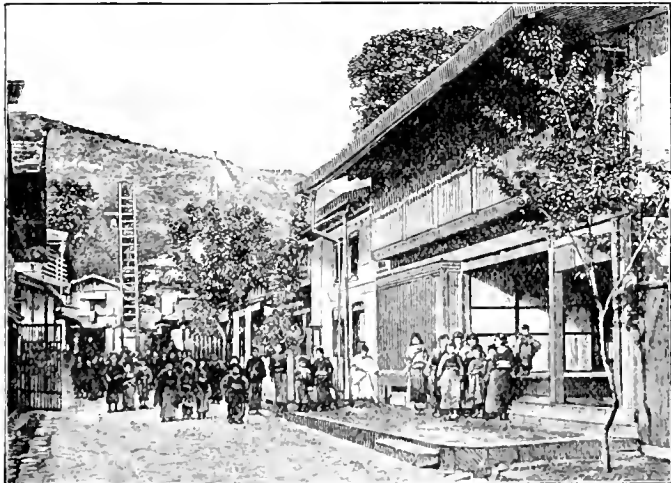

A Street Scene in SOWA.

extent by the fashionable ladies of the capital. Hats are not generally worn, except by those who follow European fashions or in the heat of summer. The women wear a loose robe, overlapping in front, and fastened with a broad heavy girdle of silk (*obi*), often of great value. In winter a succession of these robes are worn, one over the other. The

formerly universal chignon coiffure of the women, stiff with pomatum, which was done up by the hairdresser once or twice a week, is rapidly yielding to the simpler Grecian knot. The poorer classes wear nothing more than a loose cotton gown, tied at the waist, and a loin-cloth, frequently working only in the loin-cloth. Women of the lower class think nothing of exposing the person to the waist. The women powder profusely, a white skin being highly appreciated, and dye the lips a deep red; jewellery is not worn. The old-fashioned coiffure of the men, still frequently seen among the lower classes, especially among fishermen, is peculiar. The head is shaven on the top, leaving a broad rectangular bald space, and the hair of the unshaven portion, formed into a compact mass like a candle-end, is then turned forward upon the crown. The children's heads are shaven grotesquely; priests and many old women shave the head completely. Long hair is frequently worn by dis-contented politicians and philosophers, while widows wear short hair. Both Japanese men and women are fond of smoking tobacco; the bowl of the pipe they use is less in size than half a tumbler, and requires constant refilling.

Although the Japanese are a singularly united people, yet the nation divides itself into two portions, the governing and the governed. The former, representatives of the military class and numbering some 4000 families, are high-spirited and masterful; the rest of the nation are submissive and timid. Many of the seemingly contradictory opinions given forth regarding the Japanese can be reconciled by a recognition of this fact.

Mode of Living, &c.—Japanese houses are slight constructions of wood; in place of windows and shutters they have an inner set of paper screens, and an outer set of wooden shutters, both sliding in grooves. In the northern districts at least two sides of the house are closed in with walls of mud plastered on wicker-work. The floors are covered with thick soft straw mats, measuring 6 by 3 feet, and the accommodation of the houses is reckoned by the number of these mats. On them the inmates sit, eat, and sleep, the bed-clothes—heavily-padded quilts,—being kept during the day in adjoining closets. The surface of these mats is scrupulously clean, for boots and clogs are removed before entering. In winter heat is obtained from charcoal boxes, either movable or set into the floor, and most of the cooking is done over charcoal braziers. Rice is the staple food of the people, but in the poorer mountainous regions millet often takes its place. Fish, seaweed, and beans in all forms are served with the rice, especially in the soups, which likewise contain bean-curd, eggs, and vegetables. Chestnuts and hazelnuts are also largely eaten, and the walnut is made into a sweetmeat. *Shōyu* (soy), a sauce made of beans and wheat, is the universal condiment. Generally speaking, the food is unsatisfying and unwholesome to foreigners. Fowls are now pretty widely used for the table, and pork and beef, as well as bread, are increasingly eaten. The meat shops are frequented at night, as taverns are in England.

Japanese towns are subject to conflagrations to such a degree that in crowded city districts houses are supposed to last on an average only three years. The people store their valuables in square towers of bamboo wattle-work and mud, which are left standing when the fire has swept past. Incendiarism followed by robbery is a common crime, formerly punished savagely. The institution of a gendarmerie in 1881, and the more stable nature of the edifices recently erected in the capital, have greatly lessened these fires.

The Japanese are a dyspeptic people, more dying from diseases of the digestion than from any other cause. Skin diseases, well treated at the various *solfataras*, are common; bone diseases are also rife. Lung diseases are not so deadly as in Great Britain, and child-birth is attended with little or no danger. A very dangerous disease peculiar to the country and yielding to no specific remedy is *lakke*, a form of elephantiasis or *beri-beri*. Smallpox was formerly a scourge, but compulsory vaccination has remedied this. Cholera appeared in force in the year 1879, and again violently in 1886. The houses are built low on the ground, the drains are open, wells are close to closets and rubbish-heaps. However, there are now both an active sanitary society in Tokyo and a foreign professor of sanitary engineering in the university, and water-works with the latest improvements had been provided for Yokohama by 1890, when the capital and Nagasaki had also water-work schemes under consideration. Infant mortality is small. Suicide is common, especially among men, three out of four male suicides hanging themselves, one out of every two female suicides drowning herself. The figures for 1890-94 showed an annual average of 4606 men and 3000 women.

Manners and Customs.—Many of the customs once characteristic of Japan have, since the abolition of feudalism, become obsolete. Among these is *seppuku* or *hara-kiri* (see HARI-KARI), for long a legalised mode of suicide. The wearing of swords by civilians in public was forbidden by law in 1876. The social position of women is more favourable than in most non-Christian countries, but still leaves much to be desired. However, the attitude assumed by the empress and the imperial princesses is rapidly bringing about a social equality of the sexes. Formerly concubines were recognised by law, and a certain number of imperial mistresses are attached to the court, whose children are open to the succession—the present emperor and crown-prince being the sons of mistresses. A man can, however, have only one legal wife, and the keeping of concubines in the same house with a wife is more and more discountenanced by social opinion. Divorces are easily obtained by husbands, and the nuptial tie is little respected among the lower classes; but women of the well-to-do classes are modest and virtuous. Marriages are arranged through an intermediary, and both sexes marry at an early age. As the continuance of families is a point of great importance, adoption is largely resorted to in order to prevent families dying out. Prostitution is prevalent. It was formerly no uncommon thing for a dutiful daughter to sell herself for a term of years to the proprietor of a house of ill-fame in order to retrieve her father's fallen fortunes. When she returned no stigma attached to her; rather was she honoured for her filial devotion. Licensed houses of ill-fame have always been confined to certain districts, outside the city limits, and are carefully inspected. Hot baths are a great institution in Japan. Formerly it was a general custom for persons of both sexes to bathe together; and this primitive custom still prevails in rural districts, although forbidden in the cities and always unknown in Tokyo. Great respect is paid to the dead, and posthumous names are conferred after death, some of the most celebrated names in Japanese history being posthumous titles. Heavy sums are lavished on funerals.

Until lately the only vehicles in Japan were two kinds of palanquin—viz. the *lago* and the *norimono*; but in all the more level districts these have now been superseded by the *jurikisha* ('man-power-carriage'), a sort of two-wheeled perambulator drawn by a man who runs between the shafts. In many of the more mountainous regions the roads are impracticable even for the *jurikisha*.

The Japanese are essentially a pleasure-loving people, and spend comparatively large sums upon amusements. The theatre, though formerly despised by the *sumurai* class, who refused to enter its doors, forms one of the chief national resorts. The female parts are taken by men, but theatres exist where only women act. A single performance lasts from morning till sunset, and a whole household will hire a box and spend the entire day at the theatre. Many of the arrangements are primitive, especially the orchestra, whose music is thin, harsh, and monotonous. This is generally true of Japanese music, which is in a primitive stage; the principal instruments are the stringed *sumisen*, *koto*, and *kokyū*, and the wind-instruments called *shakuhachi* and *shō*, the latter mostly used at funerals. Professional musicians are in great request and are well paid, especially the young women known as *geisha*, whose dances are wonderfully graceful. Flower-shows are very popular, and flower-gardens are crowded at the proper seasons—the plum and peach blossom season being in February and March, the cherry-blossom season and the peony season in April, the wistaria season in May, the iris season in June, the lotus season in August, the chrysanthemum season in October and November. The time of greatest festivity is the New Year, now held contemporaneously with our own, when pine-trees are planted before the doors, the houses are gay with decoration, and presents are lavishly made. The favourite game at this season is *oyobane*, a kind of battledore and shuttlecock. January is the kite season; the smaller kites are of various fantastic shapes, while the larger and more powerful ones are usually rectangular. Wrestling, juggling, and archery are favourite sports, and among indoor games *go* (checkers) and *shōgi* (chess).

Language and Literature.—The Japanese language belongs structurally, like Corean and Manchurian, to the Altaic family, and like other Altaic languages, delights in long involved sentences, the introductory details being heaped up to an extraordinary length, so that when the final verb is reached many of these are apt to be already forgotten. The verbs, which are burdened with untranslatable honorific endings, come at the close of the clause. Grammatical gender is unrecognised; case is indicated by separable particles; there are no articles; prepositions follow the words they govern. The language, though difficult to master, is easily pronounced and musical. The introduction of Chinese civilisation in the 6th century was followed by a wholesale absorption of Chinese words and characters, but the language remained grammatically unchanged, as obscure and involved in its idioms and constructions as before. Chinese ideographs are said to have been reduced to a phonetic syllabary by the Buddhist priest Kobōdaishi in 810. In process of time this system, the *Hiragana*, was rendered more complex by the addition of variants, and this led, apparently, to the introduction of another and simpler alphabet, entirely without variants, known as the *Katakana* character. The revolution of 1868 caused the language to become more Chinese in vocabulary than ever, from the necessity of coining a host of new scientific terms, although many European words were also transferred *simpliciter*. A movement, powerfully supported, has been on foot for several years to introduce the Roman alphabet, a reform which would save much tedious labour, as Japanese youths have to spend years in familiarising themselves with the difficult Chinese ideographs. The literature of Japan is meagre and vapid when compared with European literature. Poetry came to be a mere matter of the manipulation of words, a feminine accomplishment, associated with fine calligraphy, although the classical poetry has left some

charming remains. Both the classical prose and poetry owe much to women writers. A cloud rested on literature during the troublous feudal times, lasting from the 12th to the 17th century. The revival of the Shinto religion by Mabuchi, Motoori (1730-1801), and other scholars was accompanied by a great improvement in style; but this Neo-classical Japanese has been servilely imitated, and is fast becoming fossilised. At present the language, though capable of expressing almost every shade of thought required in a complete modern civilisation, labours under these difficulties: (1) there are countless homonyms—e.g. fifty-four characters pronounced *kō*, often requiring pictorial explanation in speaking; (2) the colloquial and written styles differ wholly, and thus literature fails to receive fresh impulses, and is not the heritage of the whole nation. The greatest of Japanese novelists is Bakin (1767-1848), but his works are terribly spun out. The light prose, which made its appearance in the 17th century, is well represented by Yayu and Ikku. From the *Kojiki*, or 'Records of Ancient Matters,' downwards Japanese literature is full of indecencies. Much of the place nomenclature of Japan has been traced by Mr Chamberlain to an Aino source. Double names abound, a native and a Chinese form, especially for the provinces, that with the *shū* termination, as in *Shūshū*, being the Chinese form. Most family names were originally place names.

Religions of Japan.—There are two prevailing religions in Japan—*Shintō* or *Kami no Michi* ('The way of the gods'), the indigenous faith; and Buddhism, introduced from China in 552. (1) *Shintōism.*—The characteristics of Shintoism in its pure form are 'the absence of an ethical and doctrinal code, of idol-worship, of priestcraft, and of any teachings concerning a future state, and the deification of heroes, emperors, and great men, together with the worship of certain forces and objects in nature.' The principal divinity is the sun-goddess Amaterasu, from whom the Mikado is held to be descended. After the restoration the government attempted to free Shintoism from the Buddhist innovations which had contaminated it, and to revive it in its pure form as the national religion. Shintō temples are singularly destitute of ecclesiastical paraphernalia. A metal mirror generally stands on the altar, but even this is a Buddhist innovation. The spirit of the enshrined deity is supposed to be in a case, which is exposed to view only on the day of the deity's annual festival. The worship consists merely in washing the face in a font, striking a bell, throwing a few cash into the money-box, and praying silently for a few seconds; nevertheless, long pilgrimages to famous shrines and to the summits of sacred mountains are often taken to accomplish this. Shintoism is rather an engine of government than a religion; it keeps its hold on the masses chiefly through its being interwoven with reverence for ancestors and patriotic ideas. (2) *Buddhism.*—Of Buddhists there are no fewer than thirty-five sects. The monks have assumed the functions of priests, and Japanese Buddhist worship presents striking resemblances to that of the Roman Catholic Church. Notwithstanding the increased patronage recently bestowed upon Shintoism by the government, Buddhism is still the dominant religion among the people. The most popular, as well as the wealthiest and most enlightened, of the Buddhist denominations is the *Amato* or *Shinshū* sect, which recognises one God in Amida Buddha (only, however, an abstract principle personified), discourages asceticism and clerical celibacy, and cultivates preaching, the favourite topic being the duty of self-reliance. It would be a mistake, however, to suppose that a

clear line can be drawn between adherents of Buddhism and Shintoism respectively; in the popular mind the two faiths are so blended that the temples of both are frequented without much discrimination. The better-educated classes are mostly agnostics, striving more or less to regulate their lives by the maxims of Confucius. The priests retain their hold on the people largely as being custodians of the graveyards and performers of funeral rites. Their moral influence is not weighty, many being bad boys for whom their fathers have found it impossible to find good wives. In the Meiji period none of the imperial family have entered the church; they affect in preference the army and navy. Some of the more active sects, notably the Monto sect at Kyōto, which has established a large college, are rising to the occasion and sending out preachers and propagandists to meet the active forces of modern Christian missions. Japan is a land of temples,

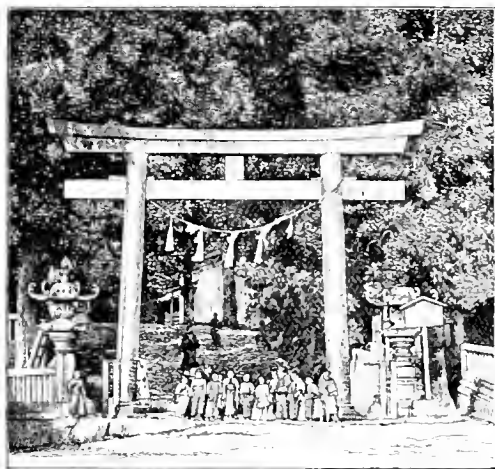

Torii of Temple, Suwa.

but many are now falling into decay, while others are turned into schoolhouses. Every grove has its shrine and *torii*, a structure in wood or stone, consisting of two upright pillars joined at the top by two transverse beams or slabs; metal torii are also not unknown. The Buddhist monasteries in the Japanese middle ages were undoubtedly wonderful centres of civilisation, and the priests for long commanded reverence by their self-denial.

Christian Missions.—Full toleration is extended to all forms of religious belief, in so far as they do not conflict with the peace and order of the community. Francis Xavier introduced Christianity in 1549, but his work was extinguished in blood, till scarcely a trace of it was left. When, however, the country was opened in 1854 it was found that 22,000 historical Roman Catholic Christians had survived persecution in the neighbourhood of Nagasaki. Christianity may be said to have finally died out in Tokyo in 1715. The Roman Catholic Church has now a bishop of north and one of south Japan, and schools and convents scattered over the country. The Greek Church has built an imposing cathedral in Tokyo, and carries on a flourishing work in the capital and the north-east of Japan. Of the Protestant missions the Presbyterians, five sects working together, and the American Congregationalists are the most flourishing. The American and Canadian Methodists, the Baptists, Episcopalians, and others are also actively at work. In 1893 the number of Protestant missionaries was 150 men, 100 mi-

married ladies, and 102 native ministers, and the membership at the 532 stations was over 20,000. There were 10,297 scholars at the mission schools, and at Sunday schools 21,597 pupils. There were 32,000 Roman Catholics, with 62 missionaries and 40 unmarried ladies; and 14,000 members of the Greek Church. Osaka is the centre of the work of the Church Missionary Society, but the bishop who presides over it and the Society for the Propagation of the Gospel resides in Tokyo. The Young Men's Christian Association of America has a resident secretary in Tokyo, and is represented by teachers in almost every province.

Education is general and compulsory. There is a complete system of local elementary, middle, and normal schools, and a central university in the capital, with five higher middle schools as feeders, one in Tokyo, the others at Sendai, Kyōto, Kanazawa in Kaga, and Kumamoto. There is also a higher normal school in the capital. The elementary school course extends over eight years (six to fourteen), four years being devoted to an ordinary and four to a higher course. There were, in 1888, 25,530 elementary schools, 52 middle schools, and 46 normal schools, besides 18 girls' high schools, 89 technical, 1741 special, and 67 kindergarten schools. The university, reorganised in 1886, when it absorbed the late Imperial College of Engineering and other institutions of a high grade, consists of five colleges—Law and Politics, Literature, Science, Engineering, and Medicine. It is attended by over 700 students, and is a powerful and well-equipped institution, costing the country £42,000 annually. On its staff are 8 German professors, 7 British, 1 American, and 1 French. Other institutions in the capital are the Music Academy, the Technological School, the Dendrological School, the Nobles' School, attended by the young crown-prince, the Peeresses' School, the Girls' Higher School, the Ladies' Institute, the English Law School, the Higher Commercial School, besides eight other commercial schools in the country. Education is perfectly free from class restrictions, even the Nobles' School being by no means exclusively aristocratic. Mission schools have been doing excellent work. The capital is full of private schools and colleges, the Seimon-Gakko, founded by H. E. Count Ōkuma; the Keiō-Gijūku, conducted by Mr Fukuzawa, one of the leaders of modern Japanese thought and editor of a popular daily paper; the Kyoritsu Gakko, &c.

The printing-press is very active. Daily newspapers abound and are sold astonishingly cheap. The press laws are stringent, and imprisonments under them frequent. During the war of 1895 the sanitary and surgical appliances and methods of the Japanese were scientifically perfect. Japanese physiologists and chemists (such as Kitasato) now rank with the foremost European and American scientists.

Army and Navy.—The Japanese army was organised after European methods in the years 1868-72 by a French military mission. A mild form of conscription (1 out of every 28 young men above twenty) came into force in 1883. The presence of German military advisers resulted in the departure in 1888 of the last of the French military mission. The soldiery carry the Murata rifle, an adaptation of the chassepot. In 1890 the army numbered, in service, 49,294, of whom 3685 were commissioned officers and 131 engineers; 1st reserve, 113,965 and 22 engineers; 2d reserve, 51,691. In 1895, after the war, the regular army was reported to number no less than 279,000 men. The navy, organised under a British naval mission, possessed in 1895, after the war, some 30 ships of all kinds, including those captured from the Chinese, and 3 modern

coast-defence gun-vessels, besides 5 obsolete steamers and sailing-vessels, some of which are used as training-ships. There were also 3 powerful ships of the latest design fitting out and in reserve, and 5 more under construction. Of torpedo boats there were 5, with 17 more under construction, also 4 stationary school ships, and 6 or 7 small fast craft for harbour defence. The three naval stations are Yokosuka, 15 miles south of Yokohama; Kure, on the Inland Sea; and Sasebo; the principal arsenal is at Yokosuka. The personnel consists of 850 commissioned officers and 12,000 sub-officers and men. The naval college was removed in 1888 from Tokyo to the island of Etajima, in the Inland Sea, close by Kure.

The Japanese police is a most efficient force, chiefly recruited from the old *samuraï*, and numbering over 27,000. A gendarmerie was established in 1881. The convict system is an excellent one, and convict establishments yield a profit to the government.

Railways.—The railway-system began with two lines, one from Tokyo to Yokohama, and the other from Hyogo to Osaka and Kyoto. In 1877 a great impetus was given to railway construction by the formation of private companies. The lines now in course of construction will, when completed, give the following trunk lines: (1) a central railway between the two capitals (finished); (2) a continuation through Hyogo to Shimonoseki; (3) a line from Tokyo to Aomori; (4) a west-coast railway by the Shinano Mountains to Niigata; (5) a line in Kyushu from the Strait of Shimonoseki to Kagoshima. Shikoku and Yezo have each one short railway. Numerous branch and loop lines are finished or under construction. The gauge is a narrow one; most of the engineers are English-trained. Total mileage open in 1896, 2500 miles.

In the *mechanical arts* the Japanese have attained to great excellence, especially in metallurgy, and in the manufacture of porcelain, lacquer ware, and silk fabrics; indeed, in some of these departments works of art are produced so exquisite in design and execution as to excel the best products of Europe. The Emperor Gotoku, eighty-third of his line, founded about 1200 a school of sword-making in Kyoto, which he himself practically superintended; Masamune (14th century) blades are the most famous. Gotô Yûjô (1435-1513) may be said to have created the art of chiselling in metals in Japan. Excellently-finished cutlery is still made in Osaka and Tokyo. The porcelain industry virtually dates from the 13th century, when Shunkei, the 'Father of Pottery,' flourished at Seto in Owari; hence the Japanese name *Setsunawo* for all kinds of earthenware. Shunkei studied for six years in China; but Japan also owes much to Korea, whence artisans arrived at various periods on the invitation of Japanese nobles. Among the most celebrated wares are the cracked Satsuma, which dates from about 1640, the Hizen, the Kaga, and the Owari. Much of the art-decoration of these is executed in Tokyo. The lacquer industry dates from prehistoric times; some of the finest specimens of lacquer ware extant date from the shôgunate of Yoshimasa (1436-80); towards the end of the 17th century lacquering perhaps reached its acme of perfection. The bronze and inlaid metal-work of Japan is highly esteemed. The best enamel (*shippô*), an art introduced from China two and a half centuries ago, is made in Kyoto. Silk-weaving is carried to high perfection, especially in the two districts of Kwanseï, round Kyoto, whose looms supply artistic silk and cotton goods, and Kwanto, round Maebashi, north of Tokyo, which supplies ordinary wearing materials. Factories with their modern improvements are, however, gradually taking the

place of the old-fashioned looms. Kyoto is also a centre for embroidered goods, often so exquisitely finished as to resemble paintings. The Japanese make neat carpenters and coopers. Their saw and plane, instead of being pushed, are drawn towards the manipulator; they are very skilful in the use of the adze, but their axe is a clumsy instrument.

Japanese *pictorial art* divides itself into several schools. The primitive school, of which the celebrated Sugawara Michizane and Kose Kanaoka are the leading names, took its rise in the 9th century. The first really native school, which is known as the Yamato Rin, and later on as the Tosa Rin, dates from 1000; it devoted itself principally to the painting of court-life scenes of ceremony, illustrations of the early native romances, careful drawings of horses and falcons, &c., landscape being subordinate. The drawing was careful and with a fine brush; gold and bright colours were lavishly used. The perspective was isometrical, and the liberty was frequently taken of ignoring the roofs of buildings when depicting the interiors. Kosen, the last famous painter of this school, died in 1866. The Chinese school, which may be traced back to 1400, reached its highest development in the great master Kano Motonobu or Ko-Hôgen (1476-1559), and held pre-eminence for three centuries. The works of this school are characterised by quiet and harmonious colouring, and a bold use of the pencil; the scenery depicted is conventional, often impossible, and nearly always in its origin Chinese. The advent of Hokusai (1760-1849) marked a new departure. Hokusai, a man of the people, struck out a new path, and is one of the most realistic of the world's painters. It is this popular school, held in comparatively slight respect in Japan itself, which has the chief attraction for foreign lovers of art.

Commerce and Industries.—The commercial and industrial progress of Japan has of late been most satisfactory. Until the year 1880 Japan had not accommodated her expenses to her income. A diminution of expenses then began, culminating, at the close of 1885, in a wholesale dismissal of unnecessary officials. The ministry of finance had already taken in hand the question of the paper currency, which fell steadily from 1879, until in 1883 it touched 80 per cent. discount. Contrary to all expectation, silver payments were resumed in 1884, a wonderful triumph of finance. Since then private companies have been encouraged to buy over government undertakings and develop new schemes. Foremost of such are the Nippon Ginko (Bank of Japan), a semi-government institution, the Nippon Yusen Mail Steamship Company, numerous railway companies, various tramway lines, &c. Japanese commercial morality and far-sightedness do not enjoy a high reputation. Wholesale transactions have been rendered impossible by want of good faith, and excellent undertakings have been nipped in the bud for the same reason. The chief ports are Yokohama and Kobe (or Hyogo), the outlet for the rich products of central Japan, now a formidable rival to Yokohama and eclipsing Nagasaki, which will always have a certain importance as long as the Takashima coal mine remains unexhausted. Niigata is a foreign port only in name; Hakodate, in Yezo, carries on a growing trade. The commercial and industrial development of Japan has of late been marvellous. In 1890-95 the exports increased in value from £11,300,000 to nearly £25,000,000; the imports from £16,000,000 to about £30,000,000. Japan is now seriously threatening the commercial and manufacturing supremacy of Britain and other European countries in many parts of the East, as in Singapore. In respect of volume of trade with Japan Britain comes first, then the United States,

then China, then France, and next India. From Great Britain come chiefly cotton and woollen goods, iron and machinery, and chemicals. The staple exports of Japan are tea (United States and Canada), silk (United States, Canada, France, Great Britain), rice (Australia, Great Britain, Germany), porcelain, coals, matches, umbrellas, clocks, mats, fans, gums, camphor, shellfish, hemp, lacquer-ware, copper, salt fish, cuttle-fish, fish-oil, fish manure, seaweed, mushrooms, &c. In 1895, of 2300 ships (1600 of them steamers) entering and clearing Japanese ports in the foreign trade, nearly 900 were Japanese (350 steamers). The development of the cotton manufacture is a significant feature in the Japanese industrial revolution; in 1896 there were over thirty prosperous cotton factories. The Japanese emigrate to Hawaii, Queensland, &c. In 1894 Britain rescinded the capitulations under which British subjects in Japan could only be tried by consular courts.

Government and Administration.—The government is a hereditary monarchy, the succession being now exclusively in the male line. The cabinet consists of ten ministers of state, presided over by a minister president, their departments being Foreign Affairs, Imperial Household, Interior, Finance, War, Navy, Justice, Education, Agriculture and Commerce, Communications (post and telegraph, &c.). There is also a privy-council, mostly composed of former ministers of state. The new constitution, laid out on German lines, is jealously careful of the supremacy of the throne. The imperial diet consists of two Houses, and its approval is necessary for the passing of every law, debates being held in public. The first general election took place in 1890; provincial assemblies were instituted in 1879. For administrative purposes Japan is divided into forty-three *ken* or prefectures and three *fu* or city governments (Tokyo, Kyoto, Osaka). The normal revenue of late years (apart from the war indemnity received from China, q.v.) has been about £14,000,000, and is usually much more than balances the expenditure. The debt in 1895 was £63,000,000. Penal and civil codes have been drafted on a European basis. Taxation mostly falls upon land; the land-tax is levied in the form of a percentage of the market value of the land. It has hitherto been impossible for Japan, owing to the restrictions imposed by the treaties, to increase the revenue from customs duties. The liquor and tobacco duties are heavy.

Coinage, Weights and Measures, &c.—The coinage is practically of silver, although gold coins are still issued. The mint for metal coinage at Osaka, organised and superintended until quite recently by British experts, turns out exquisitely finished coins. The silver dollar or *gen* has since 1880 circulated generally in the Far East on a par with the Mexican dollar; its present value is about 3s. There is a subsidiary silver coinage of 50, 20, and 10 *sen* pieces, besides a nickel 5 *sen* piece; also a copper coinage of 2 *sen*, 1 *sen*, 5 *rin*, 2 *rin*, and 1 *rin* pieces (10 *rin* = 1 *sen*; 100 *sen* = 1 *yen*). The paper mint in Tokyo turns out a redeemable paper currency.

For lineal measure, the artisan's and land *shaku* answers pretty closely to the English foot (= 3942119); the dry goods *shoku* is longer (1·212765). Long distances are measured by *ri*: 36 *cho* = 1 *ri* = 2·44034 English miles. Land is bought and sold by the *tsubo* (= 36 sq. feet). Weight is reckoned by *kin* (1 *kin* = 1·32507323 lb. avoird.) and by *kwannin* (16 *kwannin* = 100 *kin*).

On January 1, 1888, mean solar time for 135 long., or 9 hours E. of Greenwich, was adopted as standard time for all Japan. This meridian passes through Akashi, fully half a degree W. of Kyoto.

Authorities.—The works of Kaempfer (2 vols. Lond. 1727) and of Siebold (20 vols. Leyden, 1832-51) remain always classical. The best handy compendiums of information on Japan are the *Handbook for Japan*, in Murray's series, compiled by Satow and Hawes (1884), the *Ancient Japan* of Appert and Kimoshita (Tokyo, 1888), and *A Concise Dictionary of Japan: Roads, Towns, Laws, &c.*, by W. N. Whitney (Tokyo and Lond. 1890). As general treatises J. J. Rein's *Japan* (2 vols.; Eng. trans. 1884-88) and W. E. Griffith's *The Mikado's Empire* (New York, 1876) may be consulted, the first being scientific, the second popular. Anderson's *Pictorial Arts of Japan* (Lond. 1886) and Morse's *Japanese Homes* (Boston, U.S. 1886) are valuable special treatises. For the language and literature consult the grammars of Aston, Chamberlain, and Inulric, and the dictionaries of Hepburn, Satow, and Gabbins, and Chamberlain's *Classical Poetry of the Japanese* (1880). A mine of information is contained in the *Transactions of the Asiatic Society of Japan* (Lond. Trübner), the *Transactions of the German Asiatic Society*, the *Transactions of the Sismological Society of Japan*, and the *Chrysanthemum*, a monthly review now extinct. The Imperial University sends out memoirs; and there is a *Japan Weekly Mail* (Yokohama). See also works by Arnold (1891), Murray (1891), Hearn (1895), and Parsons (1896); and books on the Far East by Curzon (1894) and Norman (1895).

Japanning is the art of producing, by the aid of heat, a hard coating of coloured varnish upon metal, wood, or papier-maché. Articles so coated resemble the lacquer wares of Japan and China (see LACQUER). A japanned surface differs from an ordinary painted surface in being harder and more durable, and also in not being easily injured by hot water or by being placed near a fire. A good brown 'japan' is prepared by separately heating equal quantities of amber and asphaltum, and adding to each one-half the quantity by weight of boiled linseed-oil. Both compounds are then mixed together. Copal resin may be substituted for the amber, but it is not so durable. Tinned iron goods are most largely japanned, and for them brown and black colours are chiefly used. Both are obtained by the use of brown japan, the metal getting a preliminary coating of black paint when black is required. Only one coating of brown japan is given to cheap goods, but for better wares two or more coatings are applied. After each coating the articles are heated for ten or twelve hours in an oven at from 135 to 165 F., or even up to a much higher temperature. The japanned surface is then rubbed with fine ground pumice, next with rottenstone, and the final polish given to it by the palm of the hand. Gold or bronze bands or floral decoration, or both, are generally added. These are first painted on in japanner's gold size, and then the gold leaf is applied or the bronzed powder dusted on, after which the objects are again placed in the oven. After they are removed the gilt or bronzed portions get a protecting coat of white spirit varnish. When white or other light colours are used for japanning they are mixed with japanner's varnish. These require more careful heating in the oven than dark brown or black. Such articles as tea-trays, coal-boxes, cash-boxes, tin canisters, and the like are japanned in great numbers in Birmingham. Portable bathtubs are usually finished internally in white japan; and it may be remarked that this would last much longer than it often does if care were taken not to leave soapy water in the bathtubs after being used. The varnishing or japanning of the surface of papier-maché wares is a similar process to the above, but in the case of these shell or metal inlaying is often worked into the japan.

Japhet, according to the Hebrew record, the second son of Noah, whose descendants peopled first the north and west of Asia, after which they proceeded to occupy the 'isles of the Gentiles.' The term Japhetic or Japetic was at one time used

loosely for peoples of the European stock (nearly as Aryan and Indo-European now) as opposed to Semitic and Hamitic (Asiatic and African). See ETHNOLOGY, PHILOLOGY.

Japurá (*Yapura*), or CAQUETA, an important tributary of the Amazon, rises in southern Colombia, on the east side of the Andes, flows ESE., and enters the Amazon opposite Tefle by several arms. Its upper course is broken by many falls, but in the lower part it is navigable for river-steamer to nearly 70 W. long., or almost 500 miles.

Jargoon. See JACTUUM.

Jarl. See EARL.

Jarnac, a village in the French department of Charente, 23 miles by rail W. of Angoulême, where, on March 13, 1569, the Duke of Anjou, afterwards Henry III., and 26,000 Catholics defeated 15,000 Huguenots under Louis L., Prince of Condé (q.v.).

Jaroslav (pronounced *Yaroslaf*), capital of the Russian government of that name, stands at the junction of the Volga with its affluent the Kotorost, 173 miles by rail NE. of Moscow. The town has broad streets, a fine quay, 2 miles long, beside the Volga, nearly fifty churches, three monasteries, and a theological college; it is the seat of an archbishop. The law college (lyceum) has more than 300 students. The staple industry of the place is the manufacture of cotton stuffs; next comes the weaving of linen, wool, and silk. Jaroslav is an important river-port, and does an active trade in corn (one half), groceries, and textiles. Pop. 70,171. The town was founded in 1026, and was the capital of an independent principality until 1471, when it fell to Moscow.—The government of Jaroslav, with an area of 13,751 sq. m. and a pop. (1897) 1,073,593, spins and weaves cotton and flax, and manufactures spirits, tobacco, and chemicals.

Jarrah. See TIMBER, WESTERN AUSTRALIA.

Jarrow, a municipal borough and seaport of Durham, situated on the Tyne, 3 miles by rail SW. of South Shields and 7 miles E. of Newcastle. Its growth from a small colliery village to the thriving town has been due to the construction of its docks (since 1859), and to the establishment of Palmer & Co.'s iron-shipbuilding and marine engine works, blast-furnaces, iron foundries, gun-factory, &c., which together employ upwards of 7000 hands. Paper and chemicals are also manufactured, and coal is shipped in large quantities. At Jarrow in 682 Benedict Biscop founded the Benedictine monastery with which the name of Bede (q.v.) is inseparably associated. The chancel of the parish church, reconstructed in the 11th century, retains portions of Benedict's work; the nave was rebuilt in 1783 and again in 1866. Bede's chair is still preserved in the church. Jarrow was made a municipality in 1875. Pop. (1871) 18,115; (1891) 33,675. See Jewitt's *Jarrow Church* (1861).

Jasher, BOOK OF (*Jashar* in Revised Version; Heb. *Sepher ha-jashar*, 'the Book of the Upright'; translated by the LXX. *Biblion tou Euthous*, and by the Vulgate *Liber Instorum*; but the Peshito has *Sepher Hashar*, 'Book of Praises or Hymns'), is one of the lost books of the ancient Hebrews, which is quoted twice (Joshua, x, 13; 2 Samuel, i, 18). Regarding its character and contents there has been much speculation. Talmudic and later Jewish authorities identified it variously with Genesis (sometimes called 'the Book of the Upright'), Deuteronomy, Judges, &c., to all which notions there is the obvious and fatal objection that the two quotations from it which survive are not to be found in any of these books, and could not possibly be found in the first two, as they refer to incidents which occurred at a subsequent period

in the national history. The conjecture of the Syriac and Arabic translators has been adopted by Dr Lowth, Herder, and other scholars—viz. that the Book of Jasher was a collection of national ballads, recording the warlike deeds of the national heroes or singing the praises of otherwise celebrated men. Gesenius is inclined to adopt the same view, and suggests that it may have acquired its name, 'the Book of the Upright,' from having been written chiefly in praise of upright men. Donaldson, in an over-ingenious work, *Jashar* (1854), contended for its being a composition of the age of Solomon, and a work of Nathan and Gad. He conceived that it originated in the desire of the more religious of the community to possess a record of the national history which should chiefly set forth the righteousness of the true Hebrews, and he attempted to extract from the so-called canonical books of the Old Testament such passages as he believed to have originally formed part of it. The actual book could not have been earlier than the age of Solomon, especially if a fragment relating to the building of the temple in the Septuagint of 1 Kings, viii, be from that work. In the 12-14th centuries no less than three different works professing to be the lost Book of Jasher were produced; and in 1751 a preposterous forgery under this name (and ultimately traced to one Hive, a London printer) created some excitement. It claimed to have been translated from Hebrew by 'Alein of Britain,' and was reprinted in 1829.

Jashpur, a native state of Chutia Nagpur, in Bengal. Area, 1963 sq. m.; pop. 90,240. The country is a tableland, ranging from 2200 to 3500 feet in height, and has excellent soil.

Jasmin, JACQUES, a modern Gascon poet, was born at Agen, 6th March 1798. He has given in his *Sonnetts* (1830) a humorous account of the poverty and privations of his early life. He earned his living as a barber; but wrote poetry in his native Languedoc dialect. His first volume, entitled *Papillotes* ('Curl Papers'), appeared in 1835. He greatly enhanced his reputation by reciting his own poems in public. His poetry is full of beauty and power; the pathos of his serious and the wit of his comic pieces are of a high order. His poems were received with enthusiasm in France and even other parts of Europe. He was made a Chevalier of the Legion of Honour in 1846, and in 1852 his works were crowned by the French Academy and a prize awarded to him. He published four volumes of poems in all; the best pieces are *The Chacivari* (1825), a mock-heroic poem; *The Blind Girl of Castel-Cuille* (1835), trans. by Longfellow; *Françolette* (1840); *The Twin Brothers* (1841); *Martha the Simple* (1845); and *The Sun's Work* (1849). These poems raised Jasmin's native tongue to the dignity of a literary language, and initiated a literary and linguistic movement in the south of France which has gone on spreading and thriving since his death (at Agen, on 4th October 1864). See French Lives by Rabain (1867) and J. Andrien (1882), and vol. iii. of Sainte-Beuve's *Portraits Contemporains*, and the Life by Samuel Smiles (1892).

Jasmine, or JESSAMINE (*Jasminum*), a genus of plants of the natural order Jasminaceæ. The genus Jasmine has its calyx and corolla each 5 or 8 cleft, two stamens attached to and included within the tube of the corolla, and a two-lobed berry, one of the lobes generally abortive. The name Jasmine is from the Persian *yasmin*. The native country and the date of introduction of the Common Jasmine (*J. officinale*) are unknown, but according to Gerard it was in common use as a wall-shrub and for covering arbours as far back as 1597, and it is naturalised in many parts of Europe and Asia.

The perfume is obtained from the flowers by means of absorption in a fatty substance. An essential oil is also distilled from jasmine. The commercial oil of jasmine, however, is merely oil of ben or the like flavoured with jasmine. *J. grandiflorum*, a native of the East Indies, has flowers still more fragrant. Another Indian species is *J. Sambac*.



Jasminum nudiflorum.

—Several other species, some with erect and some with twining stems, are not uncommon in gardens and greenhouses. Some have white, and some have yellow flowers.—Cape Jasmine is a name for Gardenia (q.v.), and the Carolina Jasmine is Gelsemium (q.v.).

Jason. See ARGONAUTS.

Jasper (Gr. *iáspis*), a mineral generally regarded as one of the varieties of Quartz (q.v.), and distinguished by its opacity, owing to a mixture of clay or other substances with the silica of which it is chiefly composed. There are many kinds of jasper, some of them of one colour, as brown, red, yellow, green, white, blue, or black, and some variously striped, spotted, or clouded with different colours. Jasper is a very abundant mineral; it is found in veins and embedded masses in many rocks, sometimes appears as a rock of which whole hills are formed, and is very common in the shape of pebbles. It has been prized from the most ancient times for ornamental purposes, as it takes a high polish. The kind called *Porcellan jasper* is rather rare. It is often full of minute holes, or is cracked in all directions. It is regarded as a kind of natural porcelain, and is found in places where coal-seams have taken fire; it is thus simply a baked clay. Similar baked clays are not infrequently met with in the vicinity of intrusive igneous rocks.

Jassy, or **JASHI**, the capital of Moldavia, the northern division of Roumania, stands 5 miles W. of the Pruth, 205 miles by rail NW. of Odessa, and 289 NNE. of Bucharest. The town was almost destroyed by fire in 1827, after which it was rebuilt. The streets are broad, and are paved with asphalt, and the houses mostly one-storied and built of wood. There are more than forty Greek churches and close upon sixty Jewish synagogues. The most noticeable secular buildings are the palaces of the boyars or Roumanian nobles, both in the city and in its environs. The town has a university with about 40 teachers and 170 students. The industry is unimportant; but there is an active trade in corn, spirits, and wine, mostly with Galatz on the Danube. Pop. 70,000, of whom half are Jews, besides Armenians, Russians, Gypsies, &c. Jassy was the residence of the Moldavian princes from 1565. Here peace was concluded between Russia and Turkey in 1792. During Ypsilanti's insurrection the town was almost destroyed by the Turkish Janizaries (1822).

On a height close to the town is the residence of the former woiwodes or governors of Moldavia.

Jaszbereny, a town of Hungary, 39 miles E. of Budapest. Pop. 21,507, employed in agriculture, cloth manufacture, and wine-making.

Játaka (literally, 'relating to birth'), the name of a collection of legends, containing an account of the 550 previous births of Sákya Muni, or the Buddha. It forms a part of the *Suttapitaka*, or 'baskets of discourses,' of Pali literature, and an edition of the text, with commentary, was issued by Fausböll in 6 vols. (Lond. 1877-96). These are of great importance as the earliest collection of popular stories, many of which at an early date found their way by one channel or other to the West, and are still current as fables of Esop or as traditional and apparently indigenous folk-tales. The best English translation is that undertaken in 1895 by Professor Cowell.

Jativa, or **NATIVA**, SAN FELIPE DE, a town of Spain, 35 miles by rail SSW. of Valencia. As the *Scythia* of the Romans it was famous for its linen manufactures. It was a Moorish town until taken from them by Jayme I. in 1224. Here was born the painter Ribera (Lo Spagnoletto) in 1588. It was also the home of the notorious Borgia (Borja) family. Pop. 15,000.

Jats, the most numerous and valuable section of the agricultural population of the Punjab, number about 4½ millions. They are by many identified with the *Geta*; and some of the best authorities accept the theory that they are descended from Scythian invaders of India in pre-historic times. Some scholars believe them cognate with the Gypsies (q.v.).

Jauer, a town of Prussian Silesia, on the Neisse, 13 miles by rail S. of Liegnitz. It is famous for its sausages and its weekly corn-market, held regularly since 1404. Jauer was formerly the market for the linen-trade of Silesia and the capital of a principality; but the Thirty Years' War ruined it. It now manufactures sugar, leather, cloth, &c. Pop. (1885) 11,178.

Jauf. See ARABIA.

Jaundice, a yellow colour of the skin and conjunctiva of the eye, arising from the presence of the colouring matter of the bile in the blood and tissues, is a symptom of various disordered conditions of the system rather than a special disease. With this colouring of the skin and eyes the following symptoms are associated: the feces are of a grayish or dirty-white tint, in consequence of the absence of bile, and the urine is of the colour of saffron, or is even as dark as porter, in consequence of the presence of the colouring matter of the bile. There is sometimes, but not in the majority of cases, an extreme itching of the skin. It is a popular belief, as old as the time of Lucretius, that to a jaundiced eye everything appears yellow. This, however, is a very rare symptom.

The causes of jaundice naturally fall into two classes, those where there is mechanical obstruction of the bile-duct, and those where there is no obstruction. Mechanical obstruction may be produced by gall-stones (see CALCULUS) or thickened bile within the duct; by inflammatory swelling of its lining membrane or that of the duodenum, into which it discharges (*catarrhal* jaundice); by the pressure upon it of tumours of neighbouring parts, of the pregnant uterus, or of accumulations of feces in the bowels. Jaundice may result without obstruction of the ducts from congestion or cirrhosis of the liver, from severe mental emotions (anger, fright, &c.), and especially from the action of various poisons—e.g. phosphorus, arsenic, mercury, snake-poison—and of various acute diseases

—e.g. typhus fever, pyæmia, and above all yellow fever. In cases of obstructive jaundice, all authorities are agreed in referring the yellow staining of the skin and other tissues to absorption by the lymphatics and veins of the bile-pigment, which is secreted by the liver but not discharged into the intestine. The explanation of non-obstructive jaundice is, however, not so clear, and raises complicated physiological questions. According to one theory, the bile-pigments are formed in the blood and merely excreted by the liver; and on this view non-obstructive jaundice is caused by their defective elimination owing to diminished activity of the liver-cells. Others hold that the bile-pigments are not formed except by the action of the liver-cells; that in non-obstructive jaundice also secretion and re-absorption always take place; and that the bile-pigments continue in the circulation owing to some defect not fully understood in the processes occurring in the blood. The question must be regarded as an open one; but the latter theory seems at present most in favour.

Both prognosis and treatment of jaundice depend entirely upon the recognition of the cause to which it is due. In cases of gall-stones, catarrhal jaundice, pressure of the pregnant uterus or of fecal accumulations, and of congestion of the liver, the case usually terminates favourably; in cases of tumour and of cirrhosis of the liver the outlook is always grave; in poisoning and in acute diseases jaundice is often a very serious symptom; where it results from mental emotion it sometimes disappears quickly, but is often followed by severe nervous symptoms and death. See LIVER (DISEASES OF).

Jaunpur, the capital of a district in the North-west Provinces of India, is situated on the Gumti, here crossed by a bridge (1560-73) 712 feet in length. The former capital of a Mohammedan kingdom, Jaunpur has several splendid architectural monuments, including Ibrahim's baths (1420), mosques, and ruins of mosques and of the fort. Pop. (1881) 44,845.

Java (Djāvā), an island of the Dutch East Indies, the seat of the colonial government. It is situated between 5° 52' (St Nicholas Point) and 8° 50' (South Cape) S. lat., and 105° 13' and 114° 39' E. long. The island is washed on the N. by the Sea of Java, on the E. by the Strait of Bali, on the S. by the Indian Ocean, and on the W.



by Sunda Strait. It extends almost due west and east, declining about 15° to the south. The extreme length is about 600 miles, the breadth 40 to 125 miles, the superficial area about 49,000 sq. m. (excluding Madura, q.v.). The coast-line is not much developed; a few large bays, protected by islands, furnish safe anchorage for vessels. From end to end of the island (most probably corresponding to a volcanic line of fissure) there is a mountain-chain, named Gunning Kendang, and, especially in the western part of the island, several parallel shorter chains. To the north there are a few isolated mountains in the alluvial plain. Towards

the south the island falls in general steeply towards the sea. There are forty-three volcanoes, several of which are still active. The rivers are generally small, but become torrents when swollen by rain; only a few of them are navigable. The climate depends on the altitude; it is rather hot and unhealthy on the coast, but pleasant in the hills. The thermometer seldom indicates more than 95° F. In Batavia the average temperature is 78·5°, the extremes being 92·7° and 66·9°. The mountains rise to about 12,000 feet, and are clothed up to 9000 or 10,000 feet with luxuriant foliage; on the loftiest eminences the thermometer sometimes sinks to 32°. Generally, even in the hills, the days are hot, but moderated by land and sea breezes, which blow regularly across the island; the nights, especially in the highlands, are cool. The rainy season lasts from November to March.

The population of Java has rapidly increased; in 1850 it was 9,570,000, and in 1894, 24,643,000. At the beginning of 1888 (excluding Madura) it amounted to a total of 20,898,122. These figures included 20,614,222 natives, 228,340 Chinese, 11,665 Arabs, and 2736 other Orientals (natives of India, of Further India, &c.). The Europeans (half-castes included) amounted to 41,159. The natives belong to the Malay (q.v.) race. The Madurese, in the eastern part of the island, the Sundanese, living in the western part, and the Javanese proper differ in physique and in language. Most of them are Mohammedans, at least in name, for much of the belief of their ancestors survives in the Islam that is now practised. A few tribes, however, profess the old religion (viz. the Baduwis in Bantam and the 'Heathen' of the Tenger Mountains). The native Christians number about 12,000, and the Chinese Christians a few hundreds. How many half-castes are counted among the Europeans it is impossible to say. The inhabitants are more civilised than those of the other islands of the archipelago. One of the chief vices is opium-smoking, which is a source of income to government, and yields for Java alone about £1,000,000 a year for licenses and profit on the import. There are thirty-nine Dutch Protestant and twenty-one Roman Catholic clergymen for the whole of the Dutch East Indies, besides those who are working among the natives. Every form of religious belief is free, but proselytising is strictly prohibited.

The chief wealth of Java consists in its luxuriant vegetation, though the producing power seems to be now a little exhausted, at least to judge from the many diseases by which the plantations have been visited of late. The character of the vegetation varies with the soil and the elevation. The division (of Jungblum) into four botanical zones, up to 2000, 4500, 7500, and above 7500 feet altitude, has been commonly adopted. The fauna differs from that of the other islands of the archipelago. The animal kingdom is not very rich; tigers (which are a scourge to some parts of the island), rhinoceros, deer, and wild swine are the chief representatives of the quadrupeds; there are only a few birds that are conspicuous for their plumage, and hardly any that are distinguished by their song. Several species of serpents (some venomous) and crocodiles are found on the island. The geology of Java is still largely undetermined. For the greater part, the island belongs to the Tertiary formation, altered by many eruptions of more recent date. Some parts of Java seem to belong to the Pleistocene period; sedimentary formations of recent date are especially considerable along the north-west part of the island. Though in old times Java was called the 'land of gold,' little of that metal has been found of late; silver is scarce; and there are no other metals at all. Salt, the manufacture of which is a govern-

ment monopoly, is prepared from sea-water; and coal is worked in the Preanger, and marble in the Madium residency.

Formerly Java used to be considered as affording almost a perfect answer to the question, How can a colony best be governed? The material prosperity which resulted to the mother-country from this possession was owing, for the greater part, to the system of General Van den Bosch (introduced in 1830). Under that system the natives were compelled to cultivate part of the ground and plant staple articles on it, whilst the produce was delivered at a fixed price to the magazines of the government, and from them shipped to Europe and sold by the Netherlands Trading Company. Although this system brought large sums into the treasury of the Netherlands, a vigorous opposition against it existed almost from the beginning, since it pressed very hard on the natives. As time went on the opposition gained ground, and in name the system was given up and private planters admitted. But in point of fact, at least so far as the coffee-plantations were concerned, the system was still continued, because the income derived from this item could not be dispensed with. A commission was appointed in 1880 to consider in what way the system of coffee-planting might be altered. At that time the natives received fifteen florins (£1. 5s.) for one picul (133½ lb. avoird.), which they had to deliver at the magazines. Though private planters had been admitted before 1870, the 'Agrarian Law,' which then was promulgated, greatly facilitated the establishment of plantations by private individuals; but still the competition of the government prevented an unrestrained development. In some parts of the island (especially in the western part) where private persons are owners of the ground, or hire it from the native princes, private industry was in better circumstances; but of late diseases in the crops and a falling-off in prices have done much damage. Sugar, coffee, indigo, tea, and tobacco are planted for export. Rice is grown extensively for native consumption (and a little for export); but it is not sufficient, and other food-crops (maize, &c.) have to be cultivated. The teak-forests belong exclusively to the government, but they are managed by private persons, working under contract. The live-stock includes about two and a half million buffaloes, two million cattle, half a million horses.

Java may be considered the centre of the commerce and trade of a great part of the Dutch East Indies. In 1888, 2995 vessels entered and 3126 cleared from Java. Of the chief staple articles there were exported, in 1888, 13,529 cwt. of indigo, 576,957 cwt. of coffee, 7,381,040 cwt. of sugar, 239,657 cwt. of tobacco, 66,791 cwt. of tea, 198,073 cwt. of tin (all these by private persons or by companies), and 426,331 cwt. of coffee and 117,420 cwt. of tin by the government. The general exports and imports were valued in 1886 at £308,266 and £2,090,709 respectively on account of the government, and at £10,079,683 and £10,140,717 respectively on account of private persons. The countries which trade most extensively with Java are Holland, the Straits Settlements, and Great Britain. The leading articles of import are cotton and linen goods, wine and spirits, provisions, machinery, railway-plant, &c. Java has frequent intercourse with Europe, *via* Singapore or directly by Dutch steamers, and is connected by cable with Europe and with Australia. The telegraph system of the island is very extensive. There are good roads and railways, partly belonging to the government, partly to private companies; 566 miles of the former and 194 miles of the latter were open in 1889.

The island is (excluding Madura) divided into

twenty-one residencies: Bantam, Batavia, Kravang, Preanger Regencies, Cheribon, Tagal, Pekalongan, Samarang, Japara, Rembang, Surabaja, Pasuruan, Probolingo, Besaki (including Banyuwangi), Banyumas, Bagelen, Kadu, Jokjakarta, Surakarta, Madium, Kediri—two of which (Surakarta and Jokjakarta) are under native princes. Over each residency a Dutch resident exercises a general control. The residencies are divided into *afdeelingen*, under assistant-residents, to whom are subject the controllers (100). Subject to the supervision of these European officers the administration is carried on by native functionaries—regents at the head of the regencies (generally corresponding to the *afdeelingen*), to whom are subject the *wedono* or *denang*: the regents have substitutes called *putih*.

The languages are Javanese, a Malayan tongue, divided into an aristocratic dialect and a popular dialect, Sundanese, and Madurese. Besides there is another language used in old inscriptions and manuscripts, called *Kawi* (better, Old Javanese). The Javanese alphabet is derived from the Devanagari. Many antiquities were left by the early Hindu conquerors, especially in middle and eastern Java (Boro Budor (q.v.), Brambanan, Dieng). The literature of modern Java is rather insignificant. *Babad*s ('chronicles') and the *wayang* ('puppet-plays') stories should be mentioned.

The *history* of Java can only be given in outline. The earliest historical references date back to the beginning of the 5th century. In 412 A.D. Fa-Hien visited Hindu colonies in Java. About the year 800 the intercourse of the Hindus with the island appears to have become more important. Already by that time the Javanese had attained to a considerable degree of civilisation. To judge from the antiquities, there were three periods of Hindu ascendancy—a period of Buddhism, a period of Sivaism, and a period of compromise. Several powerful Hindu states were established, among which Madjapahit must be mentioned. At the beginning of the 15th century Mohammedanism reached the island and quickly got a firm footing. At the end of the 16th century European merchant-adventurers established themselves in Java; whilst the Dutch rule in the island began in 1610 (the first governor-general, Pieter Both). Then began a long, tough struggle with the natives, but with the lapse of time the Dutch gained ground. The most important native state then was Mataram. In 1705 the company obtained possession of the Preanger Regencies, and in 1745 its authority was extended over all the north-east coast of the island. In 1755 the empire of Mataram was divided into two states, Surakarta and Jokjakarta. In 1808 the kingdom of Bantam was incorporated with the Dutch possessions; but these in 1811 became part of the French empire. In the same year Java was occupied by the English, and remained in their hands up to 1817. A short time after the Dutch had resumed possession of Java an insurrection burst out in Jokjakarta in 1825 under Dipa Negara, and the struggle lasted until 1830, when the chief of the rebels submitted to the Dutch authorities. By that time the greater part of the states of the native provinces had been incorporated in the Dutch possessions, which then assumed the extension they have to-day.

See Sir Stamford Raffles's *History of Java* (Lond. 1817); De Jonge, *Nederlandsch Oost-Indië* (1862-88); Jungbluth, *Java* (1849-53); Worsfold, *A Visit to Java* (1893); P. J. Veth, *Java, Geographisch, Ethnologisch, Historisch* (3 vols. 1875-78). This last is the most important work on Java, though, in some respects, a little out of date. See also R. Schuing, *Nederlandsch Oost en West* (1889; a general description of the East Indian colonies, not always to be trusted); *De Loofer Handleiding tot de Kennis van het Staats- en Administratief-Recht van Nederl. Indië*

(3d ed. 1884); Worsfold's *Visit to Java* (1893); Eliza Scidmore's *Java, the Garden of the East* (1898); and Douwes Dekker's romance, *Max Havelaar* (Eng. trans. 1868). The best maps are in *Atlas der Nordindische Besitzungen in Ost-Indie*, by Stenfoort and Ten Scherff.

Jaworow, a town of Austrian Galicia, 30 miles WNW. of Lemberg, was the favourite residence of John Sobieski, king of Poland. Pop. 9159.

Jaxartes, now called SHÛN, or SYR-DARIA (both *syr* and *daria* mean 'river'), a river of western Asia, which rises at an altitude of 12,000 feet, 30 miles S. of Lake Issik-kul, in the Tian-Shan Mountains. It is at first called the Juak-tash, then the Taragai, and under the name of the Naryn it descends, through a wild narrow gorge, to the level of 6800 feet at Fort Narynsk, flowing all the while steadily west with deflections to the south-west. After passing through a series of dried-up lakes and being joined by several mountain-streams, it receives, just below Namangan, the name of Syr-Daria. A little west of Khojend it breaks through another gorge; then turns suddenly to the north-west, and, retaining that direction for 850 miles, finds its way into the Sea of Aral by a delta with three mouths. The river is navigable over this distance only (850 miles). Its total length is 1500 miles; area of its drainage basin, 320,000 sq. m. Two streams, the Tehu (600 miles long) and the Sary-su (570 miles), which formerly joined the Syr-Daria from the right, are now lost in the sands east of Perovsk before reaching it. Five centuries ago the Syr-Daria used to send off a south-western branch at Perovsk, which flowed into the Sea of Aral on its south-east side, not far from the mouth of the Amu-Daria. This branch is now likewise lost in the sand. The Syr-Daria is the Nile of Turkestan. The people fertilise their valleys by its water, carried off in irrigation channels.

Jay (*Garrulus*), a genus of short-winged, short-billed birds of the Crow family (Corvidæ), represented in the palaearctic region by about 12 species. The jays inhabit woodlands, and the adults are generally found alone or in pairs. They are almost omnivorous, feeding chiefly on berries, seeds, nuts, and fruits, but eating also worms, insects, larvae, birds' eggs, and even young mice and the nestlings of singing-birds. The well-known blue and black markings on the wing-coverts are characteristic of the whole genus, of which the Common Jay (*G. glandarius*), the only British species, may be taken



Common Jay (*Garrulus glandarius*).

as a type. This bird is comparatively common throughout England and Wales, and is found in the south and east of Ireland, and in Scotland as far north as Inverness-shire. Its numbers, however, are everywhere gradually decreasing, owing to the constant war waged against it by game-keepers on account of its partiality for the eggs of game-birds.

It is also sought after for its beautiful blue feathers, which are used in the making of artificial flies. The common jay builds, in thick trees or high bushes, a cup-shaped, basket-like nest of sticks lined with grasses. The eggs, 5 or 6 in number, are of a greenish-gray colour, thickly speckled with light-brown, and sometimes marked with fine black lines. The adult bird measures about 14 inches. The prevailing colour is a light brown, but the tail-feathers and quills are black; the wing-coverts are black, barred with bright blue and white; the head bears an erectile crest of whitish feathers with black streaks. Though the genus *Garrulus* is strictly confined to the Old World, closely allied genera, *Cyanocitta*, the Blue Jays, and *Nanuthura*, the Long-tailed Jays, are found in North and South America. The Common Blue Jay (*C. cristata*) measures 11½ inches, and is of a grayish-purple colour. It is common throughout Canada and the southern and eastern States, and sometimes does valuable service in ridding a district of caterpillars. When taken young jays are easily tamed, and are very popular as pets: for, though their natural note is harsh and unpleasant, they possess considerable powers of imitation.

Jay, JOHN, an American statesman and jurist, and first chief-justice of the supreme court of the United States, was born in New York city, December 12, 1745. He graduated at King's (now Columbia) College in 1764, and was admitted to the bar in 1768. Elected to the first Continental congress in 1774, and re-elected in 1775, he prepared addresses to the people of Great Britain and Canada, and to his own countrymen; drafted the constitution of New York state in 1777, and was appointed chief-justice of the state; was returned to congress in 1778 and elected its president, and in the following year was sent as minister to Spain. In 1782 he was added by congress to the peace commissioners, and it was mainly by his efforts that the treaty was brought to a conclusion on terms so satisfactory to the United States. In 1784-89 he was secretary for foreign affairs; on the adoption of the national constitution in 1789 he wrote in its favour in the *Federalist* (see HAMILTON); and after the organisation of the Federal government, Washington having offered him his choice of the offices in his gift, he selected that of chief-justice of the supreme court. In 1794 he concluded with Lord Grenville the convention familiarly known as 'Jay's treaty,' which provided for the recovery by British subjects of pre-revolutionary debts and by Americans of losses incurred by illegal capture by British cruisers, and the determination of the eastern frontier of what is now the state of Maine; the British were to surrender the western posts held by them in 1786, and there was to be reciprocity of inland trade between the United States and British North America. The treaty, though favourable to the United States, was passionately denounced by the Democrats as a surrender of American rights and a betrayal of France; but it was ratified by Washington in August 1795. Jay was governor of New York from 1795 to 1801. Then, though offered his former post of chief justice, he retired from public life, and passed the remainder of his days at his estate of Bedford, in Westchester county, New York. There he died, May 17, 1829. There is a good *Life* (1833) by his son, William Jay (1789-1858), who was a notable leader in the anti-slavery movement, and whose writings in favour of arbitration in national disputes exerted a considerable influence. See also the *Life* by William Whitlock (New York, 1887), and by Pellou, in 'American Statesmen' series (1890).

Jay, WILLIAM, an English Congregational minister, was born May 6, 1769, at Tisbury, in

Wiltshire. He worked at his father's trade, that of a stonemason and mason, until his sixteenth year. He was then sent to Marlborough Academy, a Congregational training college for the ministry. His first charge was at Christian Malford, near Chippenham; then he officiated for a year in a chapel belonging to Lady Maxwell; and in 1791 was called as pastor of Argyle Chapel at Bath, which position he occupied for sixty-two years. He died December 27, 1853. Jay was an impressive and eloquent preacher; he began preaching when only sixteen. As a writer he produced several works which attained to a rapid and very extensive popularity. Among them are *Morning and Evening Exercises, Short Discourses, The Christian Contemplated, Life of Rev. Cornelius Winter, Memoirs of Rev. John Clark, Lectures on Female Scripture Characters*, and an *Autobiography* (1854). A collected edition of his works, in 12 vols., revised by himself, was published in 1842-48 (new ed. 1876).

Jayadeva, the *nom de plume*, meaning 'god of victory,' of a Hindu poet, who was born at Kenduli, in Birbhuma district, Bengal, in the 12th century. His great work is the *Gita Govinda*, a Sanskrit lyric drama, in which is celebrated the love of Krishna and his wife Radha. The Hindu commentators give the poem a mystical interpretation. As the 'Indian Song of Songs' it was translated in 1875 into English by Sir Edwin Arnold.

Jazyges, a Sarmatian tribe, whose original home was to the north of the Sea of Azov. In the 1st century of the Christian era they moved westwards, finally settling in the plains of Hungary between the Theiss and the Danube, though one band seems to have gone to the north side of the Carpathians, and to have been vanquished by Hermanric, the king of the Goths, in the early part of the 4th century. The southern division of the tribe maintained an almost incessant warfare against the Danubian provinces of Rome, in spite of numerous defeats, especially by Marcus Aurelius (172) and Carus (283). Their power was finally broken by the Huns and Goths. The Jazyges were bold, savage horsemen, whose only abodes were wagons and tents. See SARMATIANS.—Jazygia is a district in Hungary, ESE, of Pesth, whose inhabitants, Magyars, have no connection with the ancient Jazyges.

Jeanne d'Albrét (1528-72), the Calvinistic mother of Henry IV. of France (q.v.), through whom he succeeded to Navarre and Béarn.

Jeanne d'Arc. See JOAN OF ARC.

Jebb, SIR RICHARD CLAVERHOUSE, a great Greek scholar, was born at Dundee, August 27, 1841. The grand-nephew of Bishop Jebb, and on the maternal side the great-grandson of Bishop Horsley, he inherited the traditions of the scholar, and passed with marked distinction through St Columba's College, Dublin, the Charterhouse, and Trinity College, Cambridge, graduating as senior classic in 1862. Soon after he was elected Fellow of his college, and he took a prominent part in organising the system of Inter-Collegiate Classical Lectures, and served as secretary to the newly-founded Cambridge Philological Society. In 1869 he became public orator of the university, in 1872 classical examiner in the university of London, and tutor of his own college, in 1875 professor of Greek in the university of Glasgow, and in 1889 regius professor of Greek at Cambridge. He has received honorary degrees from Edinburgh, Harvard, Cambridge, and Bologna, and was awarded a Greek decoration in 1878. In 1891 he was elected M.P. (Unionist) for Cambridge University. He has actively supported the teaching of modern Greek, and he helped to establish the British School of Archaeology at Athens. Professor Jebb's books are *The Characters of Theophrastus*

(1870); *The Attic Orators: Antiphon to Isocor* (2 vols. 1876-80); *A Primer of Greek Literature* (1877); *Modern Greece* (1880); *Translations into Greek and Latin Verse* (1873); *Bentley* (1882) in the series of 'English Men of Letters'; admirable school editions of the *Electra* and *Igor* of Sophocles; an *Introduction to Homer* (1887); *Lectures on Greek Poetry* (1893); and *Humanism in Education* (1899). But perhaps his most important work is his monumental edition of the plays of Sophocles, with text, commentary, and prose translation, of which the Cambridge Press issued *Edipus Tyrannus* in 1883, *Edipus Coloneus* in 1885, *Antigone* in 1888, *Trachiniae* in 1892, and *Electra* in 1894. As a scholar Jebb is equally brilliant and accurate; he shows exceptional sanity and sense of proportion, and possesses the gift of writing admirable English. In 1900 he was knighted.

Jedburgh, the county town of Roxburghshire, is beautifully situated on Jed Water, 56 miles by a branch-line (by road 49) SE. of Edinburgh. Of its magnificent Augustinian abbey, founded by David I. in 1118-47, and finally spoiled by the English in 1544-45, the ruined church only remains. This, Norman to Second Pointed in style, is 235 feet long, and has a central tower 86 feet high. In 1823 a jail (now disused) was built on the site of the royal castle (razed 1409), where a skeleton appeared to Alexander III. at his marriage-feast (1285). Other memories has Jedburgh—of Mary Stuart and Prince Charles Edward, of Thomson, Burns, Scott, and Wordsworth, of Mary Somerville and Sir David Brewster. A border town, it nurtured a warlike race, whose slogan, 'Jeddart's here!' was seldom long silent. Their chief weapon was the 'Jeddart axe,' a stout steel-headed pole, 4 feet long; and 'Jeddart justice' is still a byword for hanging first and trying afterwards. Ferniehirst Castle (rebuilt 1598; restored 1889) was the seat of the Kerrs. Jedburgh has been a royal burgh from time immemorial, and till 1885, with Haddington, &c., returned an M.P. Woollen goods have been manufactured here since 1728. Pop. (1841) 3277; (1881) 3402. See Watson's *Jedburgh Abbey* (2d ed. 1891).

Jeddah. See JIDDAH.

Jefferies, JOHN RICHARD, generally known as RICHARD JEFFERIES, English writer on rural subjects, was born at the farmhouse of Coate, 2½ miles from Swindon, in Wiltshire, on 6th November 1848. He started life as a journalist on the staff of the *North Wilts Herald* about 1866, and for twelve years was busy with this kind of work and with writing crime novels. His name first became known by a long letter to the *Times*, in November 1872, on the labourers of Wiltshire. This procured him an opening to the magazines as a writer on agricultural and rural topics. In 1877 he abandoned country journalism, and moved nearer to London, hoping to make a living by his pen. In the following year he won his first real success with *The Gamekeeper at Home*; its subtitle, 'Sketches of Natural History and Rural Life,' indicates the kind of work by which his future fame was won. Other books written in the same vein, or on similar subjects, are *Wild Life in a Southern County* (1879), *The Amateur Poacher* (1880), *Round about a Great Estate* (1881), *Nature near London* (1883), *Life of the Fields* (1884), *Red Deer* (1884), and *The Open Air* (1885). The book entitled *The Story of My Heart* (1883) is a strange autobiography of inner life. Besides these he wrote some later novels of indifferent merit; *After London*, or *Wild England* (1885) is a curious romance of the future. Within his own province, although it was not a wide one, Jefferies was an admirable writer. He possessed a wonderful insight into the habits and ways of animals and

birds and creeping things, and a great love of them. No English writer has shown a more minute and accurate acquaintance with the life of the hedge-rows and woodlands and fields of southern England. He had also a reverent feeling for nature, not only of her outward phases and aspects, but also of what may be termed her inner life. Nor were human beings excluded from the range of his observation and sympathy: he has left admirable sketches of country-folk—farmers, gamekeepers, labourers, village-loafers, &c. He died at Goring in Sussex on 14th August 1887, after a painful illness of six years' duration. See Sir Walter Besant's *Eulogy* (1888) and the *Life* by H. S. Salt (1893).

Jefferson, JOSEPH, comedian, was born in Philadelphia on 20th February 1829. He came of a theatrical stock, his great-grandfather having been a member of Garrick's company at Drury Lane, while his father and grandfather were well-known American actors. With such an ancestry it is not wonderful that young Jefferson was on the stage from his very infancy, appearing as Cora's child in *Pizarro* when only three years of age, and dancing as a miniature 'Jim Crow' when only four. For many years he went through the hard training of a strolling actor, and then played in New York, where in 1847 he made a hit as Doctor Pangloss, and in 1858 created the part of Asa Trenchard in *Our American Cousin*, Sothorn playing Lord Dundreary. In 1865 he visited London, and at the Adelphi Theatre played for the first time his world-famous part of Rip Van Winkle (4th September 1865). With this character his name is identified, and although he has shown himself an admirable comedian in many characters, to the English-speaking world he is always Rip Van Winkle. Nor is this wonderful, for the character is one of the most perfect works of art—beautiful in conception, subtle and delicate in execution. And the art is all the actor's; the dramatist has done nothing. Rip is a lazy, good-for-nothing vagabond, but Jefferson makes him 'the Arcadian vagabond of the world of dreams.' See his *Autobiography* (New York, 1890).

Jefferson, THOMAS, third president of the United States, was born at Shadwell, Albemarle county, Virginia, 13th April 1743. His father, Peter Jefferson (d. 1757), of Welsh descent, was a planter and surveyor, and a member of the House of Burgesses; his mother was a granddaughter of William Randolph (1650-1711). Thomas Jefferson was the third child and eldest son of a family of ten children. He entered William and Mary College at the age of seventeen, three years after the death of his father, and remained there two years. In 1767 he was admitted to the bar, and practised with success. In 1769 he was a delegate to the House of Burgesses, and here his first important effort was in support of a motion for the easier emancipation of slaves. The passing of the Boston Port Bill, to take effect on 1st June 1774, decided Virginia to make common cause with Massachusetts, and Jefferson favoured the resolution passed in the Assembly of Virginia to set apart the first day of June as a day of fasting and prayer. The governor, Lord Dunmore, offended by this action, dissolved the Assembly, and the members met in the Raleigh Tavern, Williamsburgh, and resolved to advise the people of Virginia to send deputies to a convention to consider the affairs of the colony and elect delegates to a general colonial congress. Jefferson was chosen a member of the convention, and, unable to attend, he sent a communication which was published under the title of 'A Summary View of the Rights of British North America.'

It was not adopted as written by Jefferson, still he was threatened by Lord Dunmore with prosecution for high-treason; and his name was included in a bill of attainder moved in parliament, but not pressed to a vote. Jefferson was a member of the second congress, which met at Philadelphia in 1775, and took his seat on 25th June, a few days after the battle of Bunker Hill. Here his unwavering devotion to his country's cause, his close acquaintance with English law, and his manner, characterised by John Adams as 'prompt, frank, explicit, and decisive,' secured him the respect of the House. He was re-elected to the third congress (1776); and on 7th June Richard Henry Lee, of Virginia, as instructed by his constituents, moved that independence should be declared. Congress fixed 1st July for the consideration of Mr Lee's motion, and meanwhile appointed a committee of five to prepare a suitable declaration on which to act; Jefferson was chairman, and the others were Franklin, John Adams, Roger Sherman, and Robert R. Livingston. By request of his colleagues, Jefferson wrote the draft of the declaration which was submitted to the House on 28th June. Lee's resolution was passed July 2, and the formal declaration, essentially as submitted, was adopted July 4, 1776.

Jefferson now resigned his seat, and, although appointed a commissioner to France with Franklin and Silas Deane, he declined the office in order to serve the people of Virginia in forming a state constitution. Among the reforms largely due to him were laws converting estates tail into fee-simple, abolishing the principle of primogeniture, and establishing the freedom of religious opinion. He succeeded Patrick Henry as governor of Virginia in 1779-81; and during the invasion of the state by Arnold and Cornwallis he was equal to the emergency. In 1783 he was elected to congress, then sitting at Annapolis, Maryland, where he secured the adoption of the decimal system of coinage. He was sent in the summer of 1784 to act with Franklin and Adams as plenipotentiary in negotiating treaties of commerce with foreign nations; but in this mission they were not very successful, the only treaties effected being with Prussia and Morocco. The next year Jefferson succeeded Franklin as minister to France, just before the opening events of the Revolution. He remained during the stormy meetings of the National Assembly and the destruction of the Bastille, performing with much tact the delicate duties of ambassador, but evidently in sympathy with the revolutionary movement. In 1789 Washington appointed him secretary of state, but he did not enter on the duties of the office till March 1790. From the origin of the two political parties, Federal and Republican, Jefferson was the recognised head of the latter, while the other members of the cabinet and the president were Federalists. On 1st January 1794 Jefferson withdrew from public life to his estate at Monticello to devote his leisure to agricultural pursuits and his favourite literary and scientific studies.

From this retirement he was called to the vice-presidency of the United States in 1797; and in 1801 he was chosen president by the House of Representatives on the thirty-sixth ballot. The popular vote re-elected him by a large majority for the next presidential term. During the eight years of his administration party spirit ran high. Among the chief events of his first term were the war with Tripoli, the admission of Ohio, and the Louisiana purchase; of his second term, the firing on the *Chesapeake* by the *Leopard*, the Embargo, the trial of Aaron Burr for treason, and the prohibition of the slave trade. For these and nearly all other acts and events of his administrations Jefferson was as warmly praised by some as blamed

by others. In 1809, after nearly forty years of public service, he bade adieu to political life and strife. Henceforth his time was devoted to the cultivation of his estate, to boundless hospitality, to the interests of education, and especially to the establishment and superintendence of the University of Virginia. He died at Monticello, July 1, 1826, a few hours before the death of John Adams. Among his papers was found this inscription for his tomb: 'Here lies buried Thomas Jefferson, author of the Declaration of American Independence, of the Statute of Virginia for Religious Freedom, and Father of the University of Virginia.' In person he was over six feet in height, with blue eyes, fair complexion, broad forehead, and, in early life, red hair. He was a good classical scholar, and proficient in the science of his day, a ready writer and fluent talker, but not an eloquent orator.

We have his *Writings, Correspondence*, &c. (9 vols. ed. by H. A. Washington, New York, 1853-54), his *Notes on Virginia* (Paris, 1781), and his *Manual of Parliamentary Practice*. See Lives by Tucker (1837), Parton (1874), and Morse (1883); also Henry Adams, *History of the United States during the First and Second Administration of Thomas Jefferson* (4 vols. New York, 1891). His authorship of the Declaration of Independence has recently been disputed.

Jefferson City, since 1826 the capital of Missouri, is situated on the south bank of the Missouri River, 125 miles by rail W. of St. Louis. It has a state-house, governor's residence, U.S. court-house, state armory and penitentiary (1500 convicts), and the Lincoln Institute, a state-supported college for coloured students. Pop. 6742.

Jeffersonville, a city of Indiana, on the Ohio River, opposite Louisville, Kentucky, with which it is connected by an iron railway bridge nearly a mile long. The falls of the river at this point are utilised in the various manufactories, which include railway workshops, foundries, machine-shops, flour-mills, &c. There are also boat-yards, and hydraulic cement is manufactured in the vicinity. One of the state-prisons is here. Pop. (1890) 10,666.

Jeffrey, FRANCIS, LORD, a Scottish judge, politician, and literary critic, was the son of a deputy-clerk in the Court of Session, and was born at Edinburgh, 23d October 1773. After preliminary education at the High School there, with Scott and Brougham as schoolfellows, he spent two sessions at the university of Glasgow, and one at Oxford. In 1794 he was called to the Scottish bar, but, having adopted Whig politics at a time when Whig opinions were not favourable to professional advancement, he made little progress for many years; indeed for long his income did not exceed £100 per annum. He was early famed for the keenness and alacrity of his intellect and for his literary tastes. In after years, when his practice increased, he was, although not an orator, remarkably successful in jury trials. In the trials for sedition between 1817 and 1822 he acquired his greatest reputation at the bar. In 1820 and again in 1823 he was elected Lord Rector of the university of Glasgow on account of the great literary distinction he had then attained as editor of the *Edinburgh Review*. In 1829 he was elected Dean of the Faculty of Advocates; in 1830 he entered parliament as member for Perth, and on the formation of Earl Grey's ministry was nominated Lord Advocate for Scotland. After the passing of the Reform Bill, with which he had much to do, especially in the measures relating to Scotland, he was returned for the city of Edinburgh, which he continued to represent until 1834, when, tired of politics, he accepted from Lord Melbourne the dignity of a lord of the Court of Session. As a judge he was noted for his carefulness and ability. From 1815 he lived at Craigerook, where he died, 26th January 1850.

It is neither as lawyer, judge, nor politician that Jeffrey has secured his chief title to fame. It is as a literary critic and as leader in a new departure in literary enterprise. It was he who, along with Sydney Smith, Francis Horner, and a few others, established the *Edinburgh Review* (q.v.). The first proposer of the scheme is supposed to have been Sydney Smith, who was the nominal editor of the first three numbers, in 1802. After that, however, Jeffrey was appointed editor at a fixed salary of £50 per number, down to 1809, and then of £200 per number down to 1829, when he resigned. His own contributions were very numerous, especially at first, and were among the most brilliant and attractive of the papers. He himself appraised as his most valuable work a *Treatise on Beauty*, which nobody now reads. His style was easy and fluent, but diffuse and at times careless. He was exceedingly well informed on a great variety of topics, but not profound. He had a fine imagination, a satirical turn, and a quickness of perception which instantly detected errors in manner or offences against taste. He had the critical faculty without being a critic in the highest sense, for he devoted himself more to analysis of method than of matter and thought. His defect as a critic was strikingly illustrated by his mistaken estimate of the Lake poets. There was always much of the partisan about him, and a robustness, not to say brutality, in his treatment of opponents, which brought him many enemies. His contributions to the *Review* numbered about 200, and a selection from them was published in 4 vols. in 1844. See the Life by his friend Lord Cockburn (1852), as also Macvey Napier's *Correspondence* (1877) and Carlyle's *Reminiscences* (1881).

Jeffreys, GEORGE, BARON, the infamous judge, was born at Aeton in Denbighshire in 1648, educated at Shrewsbury, St Paul's, and Westminster schools, and called to the bar in 1668. He rose rapidly into practice at the Old Bailey bar, and became in 1671 common serjeant of the City of London. Hitherto he had affected to belong to the Puritan party, but he now began to intrigue for court favour, was made solicitor to the Duke of York, was knighted in 1677, and became Recorder of London in the following year. He was actively concerned in many of the Popish Plot prosecutions, was made chief-justice of Chester and king's serjeant in 1680, baronet in 1681, and chief-justice of the King's Bench in 1683. His first exploit was the judicial murder of Algernon Sidney, but in every state-trial he proved himself a willing tool to the crown, thus earning the special favour of James, who raised him to the peerage soon after his accession. Among his earliest trials were those of Titus Oates and Richard Baxter, and in both he showed his customary brutality and vindictiveness. In the summer of 1685 he was sent to the west to try those involved in Monmouth's rising, and earned the Lord Chancellorship by a series of judicial murders which has left his name a byword for cruelty. Three hundred and twenty were hanged as rebels during the 'Bloody Assize,' as Jeffreys made his way through Dorset and Somerset, while eight hundred and forty-one were transported, and a still larger number imprisoned and whipped with merciless severity. A drunken and brutal bully, he heaped the foulest reproaches upon his unhappy victims, and gloated with fiendish malignity over their prospective sufferings. It was his boast that he had hanged more traitors than all his predecessors since the Conquest. He held the Great Seal from September 1685 until the downfall of James, and supported all the king's despotic measures as president of the newly revived Court of High Commission, and in the trial of the seven bishops. Yet he had rational views on witchcraft, and was too

honest to turn Catholic like many better men. On the flight of his master he tried to follow his example, but was caught disguised as a sailor at Wapping, and sent to the Tower to save him from being torn in pieces by the mob. Here he died four months after, his frame already worn out by hard drinking, April 18, 1689.

See the *Life* by Woolrych (1827) and the apologetic or eulogistic one by H. B. Irving (1898).

Jehan. See AURUNGZEBE, AGRA.

Jehlam. See JHELUM.

Jehovah. the distinctive name for God in the Old Testament, in the Authorised Version is sometimes merely transliterated from the Massoretic Hebrew text, as above, but more frequently it is translated as 'LORD' (with capital letters). The word consists of the consonants JHWH or JHWH, with the vowels of a quite separate word, Adonai ('Lord'), an indistinct E being substituted for the short A. What its original vowels were is only matter of inference, for owing to a peculiar interpretation of such texts as Ex. xx. 7. Lev. xxiv. 11, the name came to be regarded as ineffable; the scribes in reading substituted 'Lord,' and the LXX. translation has *Kyrios*. The evidence of the Greek Church fathers, who give the forms *Jaho* and *Jao* as traditional, as well as the shortened Hebrew forms of the word, *Jah* (Ps. lxxviii. 4, &c.) and *Jahu* (in proper names, such as Jimejahn or Jeremiah), indicate that most probably it was originally spoken *Jahuch* (pron. *Yahuch*). Etymologically, it is a third person singular, imperfect, probably of the verb *hawah* (or *hajah*), signifying 'to be'; as regards the 'voice,' scholars are not agreed, some supposing it to be causative, and translating 'he will cause to be' or 'he will cause to come to pass,' while others with more probability view it as a simple indicative. The text usually relied on for the explanation of the name is Ex. iii. 14, with its kindred passages. The older interpreters explain the verb (here used in the first person) in a highly metaphysical and abstract sense; the 'I am' is He who really is, the absolutely existent, the eternal. The tendency of modern exegesis is to read a more concrete and historical meaning into the expression, translating it 'I will be what I will be,' and taking it as referring to the divine sovereignty, autonomy, self-determination, freedom, but especially to the freedom of the divine grace. This view is confirmed by such a passage as Hos. i. 9: 'Ye are not my people and I am not I WILL BE for you.' Jehovah is 'He who will be'—all in all to his people; but 'eye hath not seen,' 'ear hath not heard,' 'it hath not entered into the heart of man, nor can language express the ways in which his divine grace is to show itself to them; it must be left to unfold itself in the as yet undreamed-of actualities of their lives. The language of Ex. vi. 3 (which belongs to the priestly or latest portion of the Pentateuch) has been taken as proving that the name Jehovah was of relatively late origin among the Hebrews; but, if this interpretation is correct, the representation is hardly reconcilable with what is said in Gen. iv. 26 (an older portion of the Pentateuch), or with the very early existence of proper names containing this divine name (Ex. vi. 20). The word is doubtless very old, and in all probability its earliest connotation, if known, would be found to represent a very primitive phase of religious thought (perhaps it may be 'he who causes to fall' [the rain or lightning]; see Hebrew of Job, xxxvii. 6). At one time or another in the history of Israel and of the Christian church, it has conveyed with various fullness and depth all shades of the metaphysical and religious meanings hinted at above. Certain portions of the Pentateuch, especially of

Genesis, are distinguished by the almost unvarying use of this name of God, as also are certain sections of the Psalter—a peculiarity which has an important bearing on questions of Old Testament criticism (see BIBLE). For references to the recent literature of the subject, see the lexicon of Gesenius (ed. 1890), or Driver's essay in *Studia Biblica* (1885).

Jeisk, or **Elsk,** a town in the Russian province of Kuban (Caucasus), on a small bay, at the east end of the Sea of Azov, 65 miles SW. of Azov. Founded in 1848, it has grown rapidly, exports corn, flax, and wool, and has cloth manufactures and tanneries. Pop. 27,915.

Jejeebhoy, SIR JAMSETJEE (Jamshelji Jijibhai), a Parsee merchant-prince and philanthropist, was born of poor parents at Bombay, 15th July 1783. At an early period he showed a great aptitude for mercantile pursuits, and was taken into partnership by his father-in-law, a Bombay merchant, in 1800. When peace was restored in Europe after the fall of Napoleon the Indian trade with Europe increased enormously, and in this increase these Parsee merchants participated. By 1820 Jejeebhoy had amassed an immense fortune, and now began to exhibit liberality on a magnificent scale. He contributed very generously to various educational and philanthropic institutions in Bombay, as a hospital, a poor asylum, the Parsee Benevolent Institution, and a school of art; built the Mahim Causeway; and paid most of the expenses connected with the construction of the water-works at Poona. Altogether, between 1822 and 1838 he spent upwards of a quarter of a million pounds sterling in undertakings of a purely benevolent character. Parsee and Christian, Hindu and Mussulman, were alike the objects of his beneficence. The Queen knighted him in 1842; and in 1857 he was made a baronet. He died 14th April 1859.

Jejunum, the middle part of the small intestine. See DIGESTION.

Jelalabad, a town of Afghanistan, stands near the Kabul River, about half-way between the Indian frontier fortress of Peshawar and the city of Kabul. Formerly a strong fortress itself, it is now a dirty village of about 3000 inhabitants. It is interesting from its heroic defence by Sir R. Sale in 1841-42; in the war against Afghanistan (q.v.) of 1878 it was held by the British until 1880.

Jelal-ud-din, a Sufi Persian poet (1200-73). See PERSIA (*Literature*).

Jelatou, or **ELATMA,** a town in the north of the Russian province of Tambov, 170 miles ESE. of Moscow. Pop. 7560.

Jeletz, or **ELETZ,** a town of Russia, 120 miles by rail ESE. of Orel. It exports large quantities of wheat and flour, and has a great trade in cattle. Its industries include leather, soap, candles, iron goods, lace, and linen. Pop. (1890) 36,250.

Jelf, RICHARD WILLIAM, theologian, was born 25th January 1798, the second son of Sir James Jelf. He was educated at Christ Church, Oxford, took a second class in 1820, and became Fellow of Oriel, and later, tutor. In 1826 he was appointed preceptor to Prince George of Cumberland, afterwards king of Hanover, in 1839 Canon of Christ Church, and in 1844 Principal of King's College, London. He died September 19, 1871. His most important work is his Bampton Lectures for 1844, *The Motus of Grace*. Dr Jelf was a pillar of orthodoxy, and his name will be best remembered for the part he took in the proceedings which led to Maurice being deprived of his professorship at King's College for unsound views on the question of eternal punishment expressed in his *Theological*

Essays. His Thirty-nine Articles Explained was edited by J. R. King in 1873.

Jelf, William Edward, Greek grammarian, was son of Sir James Jelf, of Oaklands, Gloucestershire, and was born at Gloucester in 1811. He was educated at Eton and Christ Church, Oxford, took a first-class in 1833, and was successively tutor and censor of his college, public examiner and proctor of the university. He was one of the preachers at the Chapel Royal, Whitehall, 1846-48, and gave the Bampton Lectures in 1857 on *Christian Faith*. In 1861 he published a letter to Dr Temple on the "Supremacy of Scripture" in answer to his famous essay on "The Education of the World." Dr Jelf died October 18, 1875. He is best remembered as the author of a *Greek Grammar*, based on that of Kuhner (1842-45; 4th ed. 1866), still the most complete in English. His *Ecumenism into the Doctrine of Confession* appeared in 1875; his *Ritualism, Romanism, and the English Reformation* in 1876; a Commentary to the 1st Epistle of John in 1877.

Jellachich, Joseph, Baron, Austrian general and Ban of Croatia, was born at Peterwardein on 16th October 1801. His father attained some celebrity in the Turkish wars and in those of the French Revolution; the son also adopted the profession of arms. Having won the entire confidence of the Croats, he was in 1848 appointed Ban of Croatia; by this appointment Austria secured the support of the Slavonian Croats against the Magyars of Hungary. Jellachich took an active part in the suppression of the Hungarian rising. He died at Agram, 20th May 1859. Not only a soldier and administrator but a poet, he published a collection of his poems at Vienna in 1851.

Jellalabad. See JELALABAD.

Jelly. For jellies made with fruit, see PRESERVED PROVISIONS. The food value of calves-foot jelly and similar jellies depends on their gelatine. See GELATINE, FOOD, DIET.

Jelly-fish (*Medusa*), bell-shaped or disc-like marine Hydrozoa, for the most part active swimmers. One set, known as Acraspeda or Acalephæ, are usually large, with a climax in a giant specimen of *Cyanea*, which had a bell $7\frac{1}{2}$ feet across, and tentacles 120 feet long. Beset with myriads of stinging cells, these "hubbbers" often make bathers more than uncomfortable. They are frequently left stranded in great numbers on the beach by the retiring tide. The common Aurelia is a well-known representative, while the exceptional Lucernarians are noteworthy in leading a more or less sedentary life attached to seaweeds and other objects. Anatomically different from the above, and included among the Craspedote Hydrozoa (q.v.), are the Trachymedusæ, of which *Geryonia* is a good type. Finally, a great number of Medusoid forms, usually small in size, very closely resemble the Trachymedusæ, but differ both from them and from the Acraspeda in being the liberated sexual "persons" of Hydroïd or Zoophyte colonies. See CELENTERATA; GENERATIONS (ALTERNATION OF); and for exact classification, HYDROZOA.

Jemappes, a village in the Belgian province of Hainault, 3 miles by rail SW. of Mons. Here the French republicans under Dumouriez, on 6th November 1792, defeated the Austrians, which victory placed Belgium in the power of the French. The village stands on one of the richest coalfields of Belgium, and manufactures stoneware, glass, and chemicals. Pop. (1885) 11,322.

Jena, a town of Saxe-Weimar, at the Leutra's influx to the Saale, 14 miles by rail SE. of Weimar,

and 31 NNE. of Saalfeld. It lies 518 feet above sea-level, engirt by steep chalk hills, of which the Hansberg (1069 feet) is crowned by the old Fuchsturm, and the Forstberg by a tower in memory of the Jena students who fell in the Franco-German war. It is still a quaint old-world place, with its ducal *schloss*, the "Black Bear" inn where Luther halted on his flight from the Wartburg, and a church whose steeple is 311 feet high. Goethe here wrote his *Hermann and Dorothea*, Schiller his *Wallenstein*; and the houses of these and of other illustrious residents were marked with tablets in 1858, on occasion of the tercentenary of the university, when, too, was erected a bronze statue of its founder, the Elector John Frederick of Saxony. He founded it in 1547-58 to take the place of Wittenberg as a seat of learning and evangelical doctrine; and it soon attained a high reputation, though not its zenith till the days of Goethe's patron, Duke Karl August (1787-1806). To that period belong the names of Fichte, Schelling, Hegel, Schiller, the Schlegels, Voss, Fries, Krause, and Oken; to our own, of Hase and Haackel. Jena now has 88 professors and lecturers, over 450 students, and a library of 200,000 volumes. In 1883 a memorial was erected of the Burschenschaft (q.v.). Pop. (1875) 9920; (1885) 12,017.

The battle of Jena is often applied as a collective name to two separate engagements fought on the same day, 14th October 1806—one at Auerstädt (q.v.), 14 miles to the north, between 30,000 French under Davout and 48,000 Prussians under the Duke of Brunswick; the other, on the heights round Jena, between 70,000 Prussians under the Prince of Hohenlohe and 90,000 French under Napoleon in person. In both the Prussians were totally defeated; and their defeat entailed that utter prostration of the Fatherland which was typified two years later by the hare-hunt held on the battlefield of Jena by the French and Russian emperors. See works by Orloff (3d ed. 1876), Ritter (1885), and, for the battle, Goltz (1883).

Jenghiz Khan. See GENGHIS.

Jenissei. See YENISEI.

Jenkins, Robert, an English merchant captain, trading from Jamaica, who alleged that in 1731 his sloop had been boarded by a Spanish *guarda costa*, and that, though no proof of smuggling had been found, he had been tortured, and his ear torn off. The said ear—some said he had lost it in the pillory—he produced in 1738 in the House of Commons; and a member asking him what were his feelings in the hour of peril, he answered, "I recommended my soul to God, and my cause to my country." Walpole next year was forced by the popular clamour to consent to war against Spain.

Jenner, Edward, the discoverer of vaccination, was born at Berkeley, in Gloucestershire, on the 17th of May 1749, and was the third son of the Rev. Stephen Jenner, vicar of the parish, and rector of Rockhampton. His schooling over, he was apprenticed to Mr Ludlow, an eminent surgeon at Sodbury, near Bristol; and in his twenty-first year went to London to prosecute his professional studies under the celebrated John Hunter (q.v.), in whose family he resided for two years. The influence of the master exerted a lasting effect on the pupil, who became an expert anatomist, a sound pathologist, a careful experimenter, and a good naturalist. In 1773 Jenner settled in his native place, where he soon acquired a large practice. In 1788 his well-known memoir, *On the Natural History of the Cuckoo*, appeared in the Transactions of the Royal Society. In 1792, the fatigues of general practice having become irksome to him, he resolved to confine himself to medicine,

and with that view he obtained the degree of M.D. from St Andrews.

The discovery of the prophylactic power of vaccination, by which the name of Jenner has become immortalised, was the result of a prolonged series of observations and experiments. He was pursuing his professional education in the house of his master at Sodbury, when a young country-woman came to seek advice. The subject of smallpox being mentioned in her presence, she observed: 'I cannot take that disease, for I have had cow-pox.' This was before the year 1770. It was not till 1775 that, after his return to Gloucestershire, he had an opportunity of examining into the truth of the traditions respecting cow-pox; and in the month of May 1780, while riding with his friend Edward Gardner, on the road between Gloucester and Bristol, he went over the natural history of cow-pox; stated his opinion as to the origin of this affection from the heel of the horse [when suffering from the grease]; specified the different sorts of disease which attacked the milkers when they handled infected cows; dwelt upon that variety which afforded protection against small-pox; and with deep and anxious emotion mentioned his hope of being able to propagate that variety from one human being to another, till he had disseminated the practice all over the globe, to the total extinction of smallpox. Many investigations delayed the actual discovery for no less than sixteen years, when at length the crowning experiment on James Phipps was made on the 14th of May 1796, and Jenner's task was virtually accomplished. This experiment was followed by many of the same kind; and in 1798 he published his first memoir, entitled *An Inquiry into the Causes and Effects of the Variola Vaccinæ*. Although the evidence accumulated by Jenner seemed conclusive, yet the practice met with violent opposition until a year had passed, when upwards of seventy of the principal physicians and surgeons in London signed a declaration of their entire confidence in it. His discovery was soon promulgated throughout the civilised world. Honours were conferred upon him by foreign courts, and he was elected an honorary member of nearly all the learned societies of Europe, though not of the College of Physicians, which required him to pass an examination in classics. Parliament voted him in 1802 a grant of £10,000, and in 1807 a second grant of £20,000; and in the year 1858 a public statue in his honour was erected in London. His latter days were passed chiefly at Berkeley and Cheltenham, and were occupied in the dissemination and elucidation of his great discovery. He died of apoplexy at Berkeley, 26th January 1823. See his *Life and Correspondence*, by Dr J. Baron (2 vols. 1827-38; 2d ed. 1850); also the article VACCINATION.

Jenner, Sir William, physician, was born at Chatham in 1815, and educated at University College, London, where he himself was professor from 1848 till 1879. He was appointed physician in ordinary to the Queen in 1862, and to the Prince of Wales in 1863; was made a baronet (1868), K.C.B. (1872), G.C.B. (1893), F.R.S., president of the College of Physicians, &c. It was he who established the difference between typhus and typhoid fevers (1851). See his *Lectures on Fevers and Diphtheria* (1893). He died 11th Dec. 1898.

Jennings, Sarah. See MARLBOROUGH.

Jenolan Caves, a series of vast limestone caverns, situated on the west side of the Blue Mountains, in New South Wales, 160 miles W. of Sydney. They were discovered in 1841, and were set apart in 1866 as public property by the colonial government. In grandeur, magnitude, and rich variety they rival the Mammoth Caves of

Kentucky. See S. Cook's *Jenolan Caves* (Lond. 1889).

Jensen, Adole, a German composer, was born in 1837 at Königsberg; from 1856 to 1868 was a musician successively at Posen, Copenthagen, and Berlin, and, his health giving way, next lived at Dresden, Gratz, and Baden Baden, where he died, 23d January 1879. He is best known by his songs and compositions for the piano.

Jenyns, Soame, was born in London in 1704; studied at St John's College, Cambridge; sat in parliament for Cambridgeshire, Dunwich, and Cambridge town; was a commissioner to the Board of Trade, and died in December 1787. As he was rich he easily acquired a literary reputation, but he lacked capacity for the high metaphysical problems that he attacked, and his books are long since securely forgotten. Indeed his name only survives from the accident that Dr Johnson criticised in the *Literary Magazine* his *Free Inquiry into the Nature and Origin of Evil* (1756). He condemned the book as shallow and inadequate, and this judgment Jenyns never forgave him. Indeed the argument was not worth his powder and shot, but Johnson in his criticism excelled himself. Jenyns, now grown orthodox, published in 1776 a no less shallow book, *View of the Internal Evidence of the Christian Religion*, for the divine origin of which he strangely argued from its utter variance with human reason.

Jephthah, one of the judges of Israel, was a base-born son of Gilead, and at his father's death was driven out from any share in his father's inheritance by the legitimate sons. He was a leader of free-booters on the border-land of Ammon until recalled by the Gileadite elders to heal them in their attempt to throw off the yoke of Ammon. He collected his warriors from all parts of Gilead and Manasseh, and before the battle made his unhappy vow to offer up for a burnt-offering the first thing that came forth from the doors of his house on his return. The Ammonites were defeated with great slaughter, and twenty of their cities taken, but as the triumphant conqueror drew near his house at Mizpeh there came forth to meet him a procession of maidens with dances and timbrels, and first among them his daughter and only child. The high-spirited maiden asked only for two months in which to bewail her hapless fate with her companions among her native mountains, and then returned to her father, and 'he did unto her his vow.' Jephthah had next to subdue the tribe of Ephraim, envious of his glory, and this he did effectually, cutting off thousands of the fugitives at the fords of Jordan, where they were identified as Ephraimites by their inability to pronounce the word *Shibboleth*. Jephthah judged Israel for six years, and died. Many theologians have found it difficult to believe that one of the heroes of faith of Hebrews, chap. xi., should have offered a human sacrifice, and have taken refuge in Joseph Kimchi's suggestion that the conditions of the vow were satisfied by a sentence of perpetual virginity; but this is to take a dishonest liberty with the plain meaning of the passage. The story of Jephthah's daughter is closely paralleled by that of Iphigenia in Greek mythology, and both are grouped together by Tennyson in his splendid poem, *The Dream of Fair Women*.

Jerablûs. See CAEGHLMUSH, HITTITES.

Jerash. See GERASA.

Jerba, a small island of Africa, off the south-east coast of Tunis, to which country it belongs. It is situated in the Gulf of Gabes, being separated from the mainland by a narrow channel. Area, 425 sq. m.; pop. 40,000, seven eighths Berbers, the rest

Jews. The soil is very fertile, and is laid out in gardens, which produce olives, dates, &c. Fine woollen textiles are made. Jerba is a centre for the Tunisian sponge-fishing. It has been held to be the home of the ancient Lotophagi; ruins of the former capital, Meninx, still exist. See EXIGAKAYSER, *Description Historique de l'Île Djérba* (1885).

Jerboa (*Dipus*), a genus of rodent quadrupeds, belonging to a distinct family, Dipodidae, remarkable for the great length of the hind-legs and kangaroo-like power of jumping. The fore-legs are very small, hence the ancient Greek name *dipous* ('two-footed'). The tail is long, cylindrical, covered with short hair, and tufted at the end.

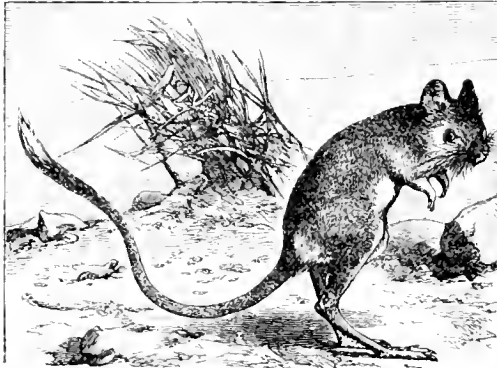

Jerboa (*Dipus aegyptus*).

The jerboas are inhabitants of sandy deserts and wide grassy plains in Asia and the east of Europe and Africa. An allied form, *Mariusus*, occurs in North America. They are burrowing animals, nocturnal, very destructive to grain and other crops, laying up hoards for their winter use. They take prodigious leaps when alarmed; the fore-feet are then not used at all, but by means of the hind-feet and the tail they leap, although they are small animals, several yards. Their flesh is said to resemble that of the rabbit.—Closely allied to the jerboas are the Gerbils (*Gerbillus*), small quadrupeds, also distinguished by great length of hind-legs and power of leaping, inhabitants of the warm and sandy portions of the Old World.

Jordan, WILLIAM, an active journalist, born at Kelso in 1782. He removed to London in 1804, reported for the short-lived *Larva* and the *Pilot* evening newspaper, next joined the staff of the *Morning Post*, and subsequently reported during three sessions for the *British Press*, contributing at the same time to the *Satirist*, or *Monthly Meteor*, the copyright of which he purchased. It was he who seized Bellingham after he had murdered Spencer Percival in the lobby of the House of Commons on 11th May 1812. In 1813 Jordan became editor of the *Sun*, but sold his share in 1817 to found the *Literary Gazette*, which he edited for thirty-three years. He lent his support to establish the Royal Society of Literature and the Melodists' Club, and in 1830 commenced the *Foreign Literary Gazette*, which died, however, in its thirteenth number. In 1852 Jordan was granted a pension of £100, while a testimonial was presented to him subscribed to by many of the first men of the day. He published his *Autobiography* in 4 volumes in 1852-53, and in 1866 *Men I have known*. He died in 1869.

Jeremiah (Heb. *Jirmijahû*, or *Jirmejâh*), the prophet, son of Hilkiah, the priest, was a native of

Anathoth (now Anata), in the territory of Benjamin, about 2½ miles NNW. of Jerusalem. In Anathoth while still young (i. 6) he received the prophetic call, described in the opening of his book, in the thirteenth year of Josiah (627-26 B.C.), and his prophetic activity, principally carried on in Jerusalem, continued for at least forty years thereafter. His teaching in its political, ethical, and religious aspects can be understood only after a careful study of the complicated circumstances of his time, which, of course, can only be broadly indicated here. It was after he had been for five years a prophet—in the eighteenth year of Josiah—that the important occurrences connected with the finding of the book of the law (2 Kings, xxii., xxiii.) took place: and, although Jeremiah is not mentioned in the history as having had any part in these, he was fully in sympathy with the reformation movement which they inaugurated, and most of his distinctive prophetic teaching had reference to it (see, for example, especially xi. 1-8; xvii. 19-27). In the thirty-first year of Josiah, when Jeremiah had been for eighteen years a prophet, occurred the death of that king on the battlefield of Megiddo, and Jehoahaz or Shallum, his immediate successor, was, after a brief reign of three months, deposed by Pharaoh-Necho, the conqueror, in favour of Jehoiakim, the subservient vassal of the Egyptian king. Jehoiakim had not been long on the throne before Jeremiah began to foretell the doom of Judah and Jerusalem, which he saw to be inevitably approaching, in the series of characteristic discourses preserved in chaps. vii.-ix. and xxvi., warning the Jewish leaders of the folly of the security with which they vainly trusted in the presence of the temple of the Lord among them, and bidding them look to the ruins of Shiloh. It was at the close of one of these discourses that he was seized by the priests and the prophets and all the people and brought before the authorities on the capital charge of having 'prophesied against the city,' and it was chiefly to the intervention of his fast friend Ahiakan, the son of Shaphan, that he owed his acquittal and release. The battle of Carchemish, in the fourth year of Jehoiakim, when the defeat and retreat of Pharaoh-Necho laid the whole of Syria and Palestine open to the approach of the Chaldeans, naturally had a profound effect upon the foreign policy of Judah; the same year marked also a new departure in the prophesying of Jeremiah, in so far as he began henceforward to declare Nebuchadnezzar's divinely-appointed mission to be to lay upon Judah a period of desolation which was to last for 'seventy' years. It was in this year that he received the divine command to commit to writing the various oracles he had up to that time delivered, and this he did with the assistance of Baruch, his disciple and friend. The incidents of the public reading of this record, and of a subsequent partial reading in the presence of the king, which led to its being committed to the flames, are among the most graphic in the whole book (xxxvi.).

Jehoiakim after a reign of eleven years was succeeded by his son Jeconiah, whose brief and obscurely-recorded reign of three months terminated in the deportation of himself and a number of his subjects to Babylon, the incident alluded to in the parable of the two baskets of figs (xxiv.). To these exiles the prophet shortly afterwards addressed the letter contained in chap. xxix., with hopeful assurances, but warning them that the captivity would certainly last for seventy years. To King Zedekiah, who had succeeded, and his advisers, Jeremiah held equally decided language, declaring the futility of all their politic devices against the Chaldean power; the watchword of his policy was 'Serve the king of Babylon

and live,' and this, in the teeth of angry and bitter opposition, he never failed to maintain, as, for example, in his public controversy in the temple court with the rival prophet Hananiah, whose theme was 'Ye shall not serve the king of Babylon' (xxxviii.). At length, in consequence of Zedekiah's treacherous and impolitic alliance with Egypt, Nebuchadnezzar, in Zedekiah's ninth year, invaded Judæa. For a time he was compelled by the appearance of an Egyptian army to raise the siege of Jerusalem, a temporary relief which led the nobles to use their influence with the king to revoke the emancipation of the slaves which shortly before had been proclaimed. This revocation, against which Jeremiah strongly protested, was the theme of his last public address (xxxiv.). Persuaded that the catastrophe he had so long foretold was only postponed, he was in the act of leaving Jerusalem in order to spend the rest of his days in retirement at Anathoth, when, on the suspicion that he was deserting to the Chaldeans, he was arrested and thrown into prison. Still adhering to his gloomy prophecy, he was consigned to the deepest dungeon, where but for the interference of Ebedmelech he would doubtless soon have perished. He was not restored to liberty until an eighteen months' siege had ended in the capture of the city, when he received from Nebuzardan permission to fix his residence where he chose. It was towards the end of the siege that he gave practical proof of his faith in the ultimate return of his countrymen to their own land by exercising his right of redemption over the ancestral lands of his family in Anathoth. Jeremiah now attached himself to Gedaliah, the governor whom the Babylonians had set over the Jews whom they had left, with his headquarters in Mizpeh; after the murder of Gedaliah he accompanied his compatriots to Tahpanes, the border city of Egypt, where, according to tradition, he died a martyr's death.

Viewed in the light of the preceding brief sketch of Jeremiah's life, it will be seen that the book of his prophecies as we now possess it does not follow any chronological order. It consists of the following four parts: (1) chaps. i.-xxxix., consisting of prophecies relating to Judah, mostly with some historical data attached, and all belonging to the period prior to the fall of Jerusalem; (2) chaps. xl.-xlv., narrative of events subsequent to the fall, along with certain prophecies belonging to that period, and also including an oracle relating to Baruch, spoken in the fourth year of Jehoiakim; (3) xlvii.-li., oracles relating to foreign nations—Egypt, Philistia, Moab, Ammon, Edom, Damascus, Kedar, and the kingdoms of Hazer, Elam, Babylon—of various dates; according to most critics, l. li. are not by Jeremiah, but by a prophet who wrote in Babylonia towards the close of the captivity; (4) chap. lii., a historical appendix closely parallel to 2 Kings, xxv.

Important critical questions are suggested by the fact that the LXX. version of Jeremiah differs considerably in its arrangement from that now seen in the Massoretic text, and that it is considerably shorter—by about one-eighth of the whole—mainly through the omission of words, clauses, and single verses. The relative value of the Greek and Hebrew recensions has not yet been conclusively determined; neither seems to deserve unqualified preference.

The distinctive advance of Jeremiah's teaching on that of his predecessors is due to his clear recognition of the fact that the divine purpose could not be realised under the forms of the Hebrew state, that the continuity and victory of the true faith could not be dependent on the continuity of the nation. Israel must be wholly dispersed, and can

only be gathered again by a divine call addressed to individuals, and bringing them one by one into a new covenant with their God, written on their hearts (xxxi.). Here for the first time in history the ultimate problem of faith is based on the relation of God to the individual soul; and it is to Jeremiah's idea of the new covenant that the New Testament teaching directly attaches itself.

The most important expositions of Jeremiah are those of Ewald (*Prophets*, vol. iii. Eng. trans. 1857), Graf (1862), Hitzig (1841), and, in English, Cheyne (*Pulpit Commentary*, 1883-85). See also Cheyne's *Jeremiah: his Life and Times* (1888), and Ball's *The Prophecies of Jeremiah* (1890); and Workman's *Text of Jeremiah* (1889) is useful, though not to be implicitly trusted.

Jerez de la Frontera. See XERES.

Jerfalcon. See FALCON.

Jericho, once one of the most flourishing cities of Palestine, two hours' journey westward from the Jordan, and six hours north-east from Jerusalem, in a well-watered and fruitful district, yielding dates, raisins, balsam, and honey, and having rose-gardens. The capture of Jericho by the Israelites on their first entry into Canaan, its destruction, Joshua's curse on the rebuilders, and the rebuilding of it in the reign of Ahab are recorded in Josh. vi.; 1 Kings, xvi. 34. It appears to have been afterwards the seat of a school of prophets (2 Kings, ii. 4, &c.). It suffered during the Babylonian exile (Ezra, ii. 34). The groves of Jericho were given by Antony to Cleopatra, and passed to Herod the Great, who resided in Jericho, beautified it, and died there. It was destroyed in the reign of Vespasian, and again rebuilt under Hadrian. In the time of the crusades it was repeatedly captured, and at last completely destroyed. The place is now a shapeless ruin, with a miserable village, Ribā or Arīhā, and excavations into the green mounds have only disclosed sun-dried bricks, of which it has been thought the walls of the city may have been built.

Jerked-beef, beef preserved by drying in the sun. It is properly called *charqui*, and, like its name, is originally of Chilian origin.

Jeroboam, the first king of the divided kingdom of Israel. He belonged to the tribe of Ephraim, and for his capacity was raised by Solomon to be superintendent of the labours and taxes exacted from his tribe at the construction of the fortifications underneath the citadel of Zion. The growing disaffection of his tribesmen and the alienation from Solomon of the prophetic order fostered his own ambition; but he was soon obliged to flee to Egypt for safety. After Solomon's death he returned to head the revolt of the northern tribes against Rehoboam, and established his chief strongholds in Shechem on the west and Penneh on the east. In order to destroy the religions as well as the political unity of the ancient kingdom he now established shrines at Dan and Bethel to wean away his people from the sacred yearly pilgrimages to Jerusalem, and, further, set up in these images borrowed from the animal-worship of the Egyptians. Thus his name has descended in proverbial infamy as 'Jeroboam, the son of Nebat, who made Israel to sin,' and Roman Catholic writers found in him a convenient parallel to Henry VIII. at the time of the Reformation. Jeroboam suffered a defeat from Abijah, son of Rehoboam, and died soon after in the twenty-second year of his reign.—Jeroboam II. was the son of Joash, of the dynasty of Jehu. He thrust back the Syrian invaders, reconquered Ammon and Moab, but earned the denunciations of the prophets Amos and Hosea by failing to reform religion at home.

Jerome, SE (EUSEBIUS HERONYMUS SOPHRO- NIS), was born at Stridon, a town whose site is

now unknown, on the confines of Dalmatia and Pannonia, at some period between 331 and 345—probably nearer to the latter year. His parents were both Christians. His early education was superintended by his father, after which he studied Greek and Latin rhetoric and philosophy under Elinus Donatus at Rome, where he was also admitted to the rite of baptism. After a residence in Gaul, he seems to have revisited Rome; but in the year 370 he had settled in Aquileia with his friend Rufinus. For some unknown reason he suddenly went hence to the East; and after a dangerous illness at Antioch, which appears to have still further added to the religious fervour of his disposition, he retired, in 374, to the desert of Chalcis, where he spent four years in penitential exercises and in study, especially of the Hebrew language. In 379 he was ordained a priest at Antioch, after which he spent three years in Constantinople in close intimacy with Gregory of Nazianzus; and in 382 he came on a mission connected with the Meletian schism at Antioch to Rome, where he became secretary to the pope Damasus, and where, although already engaged in his great work of the revision of the Latin version of the Bible, he attained to great popularity and influence by his sanctity, learning, and eloquence. Many pious persons placed themselves under his spiritual direction, the most remarkable of whom were the lady Paula and her daughter Eustochium. These ladies followed him to the Holy Land, whither he returned in 385. He permanently fixed his residence at Bethlehem in 386, the lady Paula having founded four convents, three for nuns, and one for monks, the latter of which was governed by Jerome himself. It was in this retreat that Jerome pursued or completed the great literary labours of his life; and it was from these solitudes, all peaceful as they might seem, that he sent forth the fiery and vehement invectives which marked not only his controversy with the heretics Jovinian, Vigilantius, and the Pelagians, but even with his ancient ally, Rufinus, and, although in a minor degree, with St. Augustine. His conflict with the Pelagians rendering even his life insecure at Bethlehem, he was compelled to go into concealment for above two years; and soon after his return to Bethlehem in 418 he was seized with a lingering illness, which terminated in his death, September 30, 420. His original works, consisting of letters, treatises, polemical and ascetical commentaries on Holy Scripture, and his version and revision of former versions of the Bible, were first published by Erasmus, 9 vols. folio (Basel, 1516), and have been several times reprinted. The best editions are that of the Benedictines (5 vols. folio, Paris, 1693-1706) and, still more, that of Vallarsi (11 vols. Verona, 1734-42). St. Jerome is universally regarded as the most learned and eloquent of the Latin Fathers. His commentaries on the Bible are especially valuable for the learning which they display; but his opinions are often exaggerated and fanciful, and through his controversial writings there runs a strain of violent invective, which contrasts unfavourably with the tone of his contemporary, St. Augustine. See the article VULGATE; also the works by Zoëcker (Gotha, 1865), Amedée Thierry (Paris, 1867), Goelzer (Paris, 1886), E. L. Curtis (S. P. C. K. 1878), and Mis Martin (1888); and the translations by Fremantle (1893).

Jerome Bonaparte (1781-1860), king of Westphalia. See BONAPARTE.

Jerome of Prague, the friend and disciple of Huss, was born at Prague between 1360 and 1370. The statement that his family name was Faulfisch is incorrect. After attending the university of his native town, he studied for some

time in Oxford, where he became a convert to Wyclif's doctrines. When he reached home he zealously taught the new doctrine he had learned in England. He further studied at Paris, Heidelberg, and Cologne, and acquired a reputation for learning and energy. Ladislaus II., king of Poland, employed him to help to reorganise the university of Cracow in 1410; and Sigismund, king of Hungary, invited him to preach before him at Budapest. Jerome entered with his whole soul into the contest carried on by Huss (q.v.) against the abuses of the hierarchy and the profligacy of the clergy. But his impatient zeal led him to overstep the bounds of prudence, and even to abuse the authority he possessed. When Huss was arrested at Constance Jerome voluntarily hastened to his side to defend him, although he was not provided with a safe-conduct. Arrived at Constance, he was met by sinister rumours as to the fate in store for Huss and himself. He hastily withdrew from the city, and applied for a safe-conduct. It was refused; thereupon Jerome set out to return to Prague, but was arrested at Hirschau in Bavaria in April 1415, and conveyed to Constance. After four months' imprisonment he recanted his opinions; but eight months later still (in May 1416) he boldly withdrew his recantation, and in the same heroic spirit went to the stake, 30th May 1416. See works in German by Helfert (1853) and Becker (1858), with others cited at HUSS and WYCLIF.

Jerrold, DOUGLAS WILLIAM, author, dramatist, and wit, was born in London, January 3, 1803. He was the youngest son of Samuel Jerrold, actor and manager, by his second wife. His infant years were passed at Wilsby, near Cranbrook in Kent. In 1807 his father became lessee of the theatre at Sheerness. Here, with Gesner's *Death of Abel* and *Roderick Random*, Douglas Jerrold as a child of six or seven began to manifest a voracious appetite for books. About the end of 1809 he was sent to school at Sheerness; in December 1813 he joined the navy as a midshipman. On the close of the war his ship was paid off; and the first day of January 1816 saw the arrival of the Jerrold family in London, where, from Broad Court, Bow Street, Douglas Jerrold started life anew as a printer's apprentice. In 1819 he was a compositor on the *Sunday Monitor*, when the following incident probably decided his bent towards literature: he had been to see *Der Freischutz*, and, having written a criticism on it, dropped it into his employer's letter-box, and the next morning was handed his own copy to set up, with an editorial note to the anonymous correspondent requesting further contributions. Jerrold's capacity for study was enormous, and his perseverance indefatigable; night and morning he worked at Latin, French, and Italian, besides getting through a vast amount of reading. He became dramatic critic, as well as compositor, on the *Monitor*. In 1821 he married Miss Mary Swann. Before this date he had already made a start as a dramatist; four of his pieces had been produced, the first of which, *More Frightened than Hurt* (written when Jerrold was about fifteen), came out in 1821. In 1825 Jerrold was engaged, at a weekly salary, to write dramas, farces, &c., as required, for the Coburg Theatre. In 1829 he was engaged at five pounds a week to write in a similar manner for the Surrey Theatre, where in that year *Black-eyed Susan* was acted for the first time. From this date up to 1854, when *The Heart of Gold* came out at the Princess's Theatre, numerous plays were produced, each one of which was characterised by the author's unique style and brilliant and sparkling dialogue. Jerrold's contributions to periodical literature began soon after he commenced life in London, with occasional verses and sketches in the various magazines of

the day; as his position became more assured he contributed to the *Monthly*, the *New Monthly*, *The Ballot* (which he sub-edited), *Punch in London* (a short-lived prototype of *the Punch*), the *Athenian*, *Blackwood's*, and other periodicals. *Punch* was started in 1841, and Jerrold was a constant and important contributor from its second number up to the time of his death. He successively edited the *Illuminated Magazine* (1843-44), *Douglas Jerrold's Shilling Magazine* (1845-48), and *Douglas Jerrold's Weekly Newspaper* (1846-48). In these periodicals, along with *Punch*, appeared much of his best work. In politics—and his was no mean political force—Jerrold was Liberal, and in 1852 he accepted the editorship of *Lloyd's Weekly Newspaper* of which it has been said that he 'found it in the street, and annexed it to literature.' As a wit, for what has been well termed 'flashing insight,' Jerrold stands alone. He died at Kilburn on June 8, 1857. A collected edition of Jerrold's works, in eight volumes, was published during his lifetime; it contains his principal writings, *St Giles and St James*, *The Man made of Money*, *The Story of a Feather*, *Cakes and Ale*, *Punch's Letters to his Son*, *Punch's Complete Letter-writer*, *Chronicles of Cloacynook*, *Mrs Caullie's Curtain Lectures*, &c., and fewer than half of Jerrold's dramatic works. A selection from Jerrold's political writings in *Lloyd's* was published in 1868 under the title of *Other Times*. *The Life and Remains of Douglas Jerrold*, by his son, W. Blanchard Jerrold, was published in 1859.

WILLIAM BLANCHARD JERROLD, eldest son of the above, born in 1826, was named after Laman Blanchard (q.v.), who was his godfather, and whose daughter he married (1849). Educated as an artist, Jerrold early abandoned art for literature, his chief work as artist being the part he took in the production of Howe's *Illustrated Book of British Soaps*. He served his apprenticeship to literature on his father's newspaper, and for a short time was reporter on the *Daily News*. On his father's death Blanchard Jerrold became editor of *Lloyd's*, which office he continued to the time of his death, March 10, 1884. He was appointed (1852) Crystal Palace Commissioner to Sweden, and on his return published his interesting *Bray-broker with the Sirenes* (1854). He was founder and president of the British section of the International Literary Association. A facile and voluminous writer, he published *Children of Lætitia; Cant, per Cent.; a Story written on a Bill Stamp; Life of George Cruikshank; Life of Napoleon III.; Life of Doré; and London—a Pilgrimage, &c.* Of his dramatic writings the best known is *Cant us a Cucumber* (1851), one of the most successful farces ever written.

Jerrymander. See GERRY.

Jersey, the chief of the Channel Islands (q.v.), 14 miles from the Norman coast, 133 from Southampton, 95 from Weymouth. Measuring 11 miles by 5½, it is 45 sq. m. in area, of which nearly two-thirds is cultivated. Pop. (1806) 22,855; (1851) 57,020; (1881) 52,455; (1891) 54,518, one-half rural, the rest in the capital, St Helier, and suburbs. The land rises to the north, sloping to the south and west. On all sides are large open bays; Boulay on the north is capable of becoming a fine harbour, which is at present much wanted, that of St Helier being dry at low-water. The highest point, Mount Mado, is 473 feet high; its mass is a porphyroid granite which extends south as far as St Peter's. Smaller masses of the same are found in the south-east. The north-east part is conglomerate, and the rest of the island is chiefly divided between siliceous and schistose rock; the lower levels are covered with clay and blown sand. The rocks on the coasts, being mixed with veins of

greenstone and shale, have been eroded by the sea, which has left a number of caverns and pinnacles of fantastic form. About the south-east are numerous reefs of primitive rock which render the approach dangerous. Between Jersey and the French shore the Ereehos, Bouffetins, and Minquiers indicate a former connection with the mainland, and thus confirm the traditions which tell of a separation in comparatively recent times. It is also noticeable that moles and toads are found in Jersey, as also in Alderney, while there are none in Guernsey. Agriculture is pursued on small farms held on feudal tenures resembling copyhold. The chief present staple is the potato, the early produce of which comes into the London market a fortnight before that of the west of England, and thus commands a high temporary price. Consequently other cultivation has been much neglected, and the land greatly stimulated by artificial manures. The potato export exceeds 60,000 tons yearly, of a value of £264,000. The rearing of cattle is also lucrative; it is estimated that there are fifty-eight head of cattle to every 100 acres—nearly three times the ratio of the United Kingdom. The purity of the breed is maintained by careful official registration, and the stock fetches high prices from breeders in England and America. The number of cattle exported averages nearly 1600 head annually (see CATTLE, Vol. III, p. 22). The imports consist largely of potatoes and butcher-meat, from France and England, as the island produces little food for its own consumption. There is a large and well-kept market in St Helier, and a number of good shops. There are twelve parishes in all, of which the rectors and constables are *ex-officio* members of the 'states,' the rest of the assembly being elected deputies, with the addition of the twelve jurats, or judges of the royal court, whose chief is the bailiff, a trained lawyer. The language of deliberation and judicial business is French, though the people among themselves either use English or a form of the ancient Norman. The parish churches are old, but have lost many traces of their primitive architecture in frequent restorations. The royal court is a large but ill-lighted building containing some pictures, the best of which is a full length portrait of Marshal Conway, by Gainsborough. The character of the people is orderly and frugal, the deposits in the savings-bank exceeding £300,000. There is little pauperism and hardly any serious crime.

See Ansted and Latham's *Channel Islands* (Lond. 1862); also articles in the *Fortnightly Review* by the Right Hon. G. Shaw-Lefevre and Rev. Barham Zincke, and one by the present writer in the *English Historical Review* for 1887.

Jersey City, after Newark the second city of New Jersey, and capital of Hudson county, is on the west bank of the Hudson River, opposite New York, of which it is, though in another state, an extension, and with which and Brooklyn it is connected by steam ferries; a tunnel was being made in 1874-95; and a bridge was sanctioned in 1894. It stands on a peninsula bounded on the west by the Hackensack River and Newark Bay; on the south-east it extends along New York Bay. Jersey City is a busy but not a beautiful city. It is the terminus of six great and as many local railways, and is connected with Easton, Pennsylvania, by canal; and at its wharves many ocean-steamers receive and discharge their freight. It is thus the entrepôt of a large trade, especially in iron, coal, and agricultural produce. Its own manufactures are on a large scale, and include sugar, flour, iron and steel, zinc, boilers and machinery, locomotives, oils and chemicals, oakum, lumber, silk, watches and jewellery, lead pencils, tobacco, pottery, soap, beer, &c. The city has large abattoirs and stock

yards, and grain elevators notable both for their size and efficiency. The site of Jersey City was formerly called Paulus Hoeck (Hook); the town received its present name and became a municipality in 1838. Pop. (1860) 29,226; (1870) 82,546; (1890) 163,003.

Jerusalem. *Its Site.*—Jerusalem—31° 46' 50" N. lat. and 35° 13' 25" E. long.; height, 2364 to 2582 feet above the sea-level—stands on the spurs of two hills surrounded and divided by two valleys, once deep, now partly or wholly filled up with rubbish. The exact form of the hills has recently been ascertained by taking, whenever practicable, a series of rock levels, of which 250 have been (1890) correctly laid down over the whole area of the city. More are being added from day to day, and the contours have been settled by Major Conder, the surveyor of western Palestine, with a general accuracy which can only be questioned at a few points. The dividing valley had two shallow branches within the city, a fact of considerable importance in considering the course of the second wall. The Eastern Hill was originally a rounded top crowned with the 'threshing-floor of Araunah,' and the rock and cave, probably a sacred site from time immemorial. It sloped steeply to the west and gradually to the east; its southern extremity was a tongue of land between the central valley, the Tyropoeon, and the eastern valley of the Kedron.

shalaim, mentions other forms—*Urishallum*, *Urishalum*, and *Shallam*, as formerly used in the days of the Jews. It is first mentioned in Joshua, x. 1—'Adoni-zedek, king of Jerusalem.' Afterwards, in the same book, it is spoken of as Jebus, or Jebusi, 'which is Jerusalem.' It has therefore been inferred that the name of Jerusalem was given to the city by David. But the name was found in 1890 on the cuneiform tablets from Tel-el-Amarna; it there appears as *Urusalem*, the 'City of Peace.' It was therefore known under that name at least 500 years before the conquest by David. The northern boundary of Judah is drawn south of the Jebusite; therefore it is reckoned among the cities of Benjamin. In some passages, however (e.g. Psalm, lxxviii. 68), it is held to belong to Judah. The conquest of the city by the Israelites proved at first incomplete; before the time of the Judges it was again 'the city of the stranger.' Finally conquered by David, the Lower City was united to the Fortress of the Upper Hill and the whole surrounded by a wall.

Its History.—The history of Jerusalem covers a period of about 3500 years. Of these, 500 at least are prehistoric, though glimpses of this long period may hereafter be arrived at from the treasures of the cuneiform inscriptions. Of the 3000 years which remain, less than 500 show us Jerusalem independent, the capital of a free country, and the centre of a national religion.

For 600 years longer the city was in the hands of the Israelites, it is true, but never wholly independent, always a prey to internal factions, and alternately the possession of Egypt or some other powerful neighbour. Loss of independence, banishment from the city, persecution and exile, have only made the Jew look with more passionate eyes of longing upon the city which, when it was his own, he could not hold without idolatry, contempt of his own laws, and internal dissensions. Only 500 years of independent tenure! That period removed by more than 2000 years; yet the passionate love of the Jew for Jerusalem is no whit diminished.

Here are the landmarks of its history. Its name is found on an inscription 500 years at least before David (see also Gen. xiv. 18); it was besieged almost

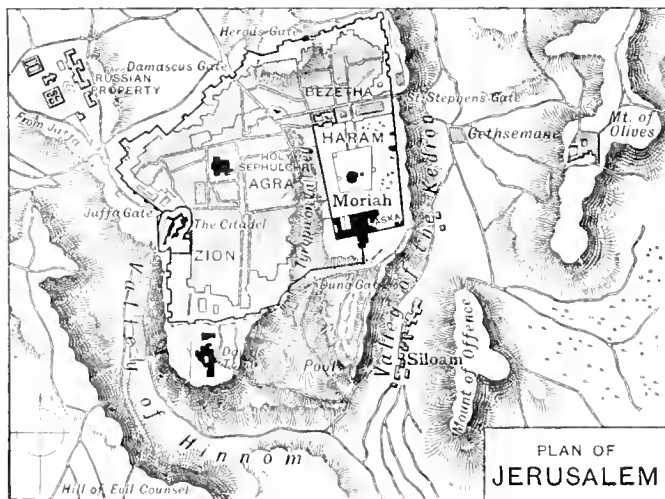

The Western Hill, higher than the other by more than a hundred feet, presented similar characteristics of a steep valley on either side and a tongue of land running southwards. Either hill was therefore a strong natural fortress, a hill fortress, such as are found in great numbers in England—e.g. the ancient stronghold called Castle Neroche, in Somersetshire, seems to be exactly the kind of fortress which David stormed. The weakness of the place for purposes of defence lay in its insufficient supply of water. One spring, that now called the 'Virgin Fount,' lies just without the old city wall of Ophel. The rock-cut passage, which runs from this spring to the Pool of Siloam below, enters within the course of the old Ophel wall. There is also a well called Hammam es-Shafa in the very centre of the city, close to the Bab al-Kattanin ('Gate of the Cotton Merchants') in the Haram area.

Jerusalem is known to the Moslems as *Beit el-Mukaddas* or *Beit el-Mukdis*, the 'Holy House,' or *El-Kuds*, 'The Holy.' Yaqut, the great Moslem geographer, who knew the Jewish name *Yeru-*

immediately after the death of Joshua, *circa* 1400 B.C.; it was again taken by David about 1046 B.C.; it was surrendered by Jehoiachin 597 B.C.; it was taken from Zedekiah 586 B.C., and wholly destroyed. Fifty years later (536 B.C.) the edict of Cyrus enabled the people to return; the temple was rebuilt; for a hundred years parties of the Jews straggled back. Ezra arrived 457 B.C., Nehemiah 445 B.C. For 500 years after this Jerusalem knew not a single generation of peace. Internal factions tore it to pieces; the city was the possession in turn of Persian, Macedonian, Syrian, Egyptian, and Roman. It was never wholly independent; there was never any real independence for Jerusalem after its destruction by Nebuzaradan. It is a great pity that those who study the history of Jerusalem generally pass over the period from Nehemiah to Herod as of little interest. It is, on the other hand, a time of the greatest interest, and full of instruction for those who study the development of the fiery Judaean race. We hear no more about Baal-worship and the groves of Asherah; the

pagan cult was growing obsolete; the gods of Hellas had invaded Syria; those of Phœnicia were forgotten. Under Antiochus the temple was consecrated to Zeus Olympios; pigs were sacrificed on the altars; the Jewish rites and ceremonies—the observance of the Sabbath, the sacrifices enjoined by the law, the rite of circumcision—were forbidden. Had it not been for one family—the most illustrious rebels on record—the religion of the Jews would have been abandoned and their nationality lost. How both were saved belongs to the history of this period (see MACCABEES).

It is not, however, a time on which the historian dwells with pleasure. The character of the people, always fiery and full of zeal, turned to fanaticism; their respect for the law, forced upon them by persecution and disaster, turned to a worship of the letter; they divided into sects which hated each other more bitterly than they hated the Gentile. The picture of Jerusalem and its people during the fifty years which preceded the destruction of the city by Titus is nowhere surpassed in all the dark annals of religious zeal. The city was besieged, taken, and totally destroyed by Titus, 70 A.D.

During the long history of Jerusalem—the City of Peace—it sustained seventeen sieges; twice it was utterly destroyed and razed to the ground. There is no city in the world whose soil has been more repeatedly drenched with the blood of its people—the thousands who have perished by the sword within these gray walls from the time when the 'children of Judah smote it with the edge of the sword and set it on fire' to the day when Godfrey de Bouillon and his knights rode in a stream of blood reaching to their saddle girths to recover the Holy Sepulchre.

The history of the city to the destruction by Titus is the history as contained in the Bible; that which follows is a second volume divided into four chapters. The first chapter contains the early centuries of Christianity, for the most part a peaceful time when the land was covered with monasteries, churches, and hermitages; when the voice of psalm and prayer never ceased day or night. The city contained the great group of churches of which the most splendid was Constantine's Basilica of the Anastasis, built not *over* the sepulchre, but to the east of it, the sepulchre itself being ornamented with columns and open to the sky. Pilgrimages began at first to the site of the Ascension, afterwards, as other sites were miraculously recovered, to that of every scene in the gospel history. The Persians came 614 A.D., sacked the city, and destroyed all the churches. Then the Moslems appeared, and the gates were thrown open without a blow.

The second chapter contains the Moslem rule (637-1099). Then the Mosque el-Aksa was built, Justinian's great church of St. Mary furnishing the principal edifice; the Dome of the Rock was built; and, by order of the mad calif Hakem Bi Asur Allah, the church of the Holy Sepulchre was again destroyed.

The third chapter is that of the Latin kingdom (1099-1244). The constitution of this kingdom, as contained in the *Assises de Jerusalem*, is the most valuable document extant on the principles of feudalism. The kingdom, after continuous war for eighty-seven years, lost Jerusalem, nor did the crusaders ever succeed in retaking it. It was, however, ceded by treaty to Frederick II., who in 1229 crowned himself in the church with his own hands, being then under papal excommunication.

The last chapter is that of Jerusalem again under the Moslems (since 1244). It was in 1517 that the Turkish sultan Selim took Jerusalem. The seven hundred years covered by this chapter have been for the most part years of peace. The

chronicles of later years are barren and devoid of incident.

Its Monuments.—The principal buildings and monuments for which the explorer of the modern city has to look are the first, second, and third walls of the great temple itself; the royal towers of Phasaelus, Hippicus, Psephinus and Mariamme; the Tyropœon Bridge; Baris or Antonia; Ophel; the Tombs of the Kings; and certain pools. It would be strange indeed if, after so many sieges and so many generations, much should survive of the city of Herod, to say nothing of the city of Solomon. There is, however, more than might have been expected, more in proportion than remains of ancient Rome of the former date; far more than remains of Tyre, Carthage, or Corinth. The town was so carefully examined by the ordnance survey of Sir Charles Wilson in 1865 that it seemed as if everything above ground must have been found. Yet we must not forget that Clermont Ganneau found above ground the inscribed stone of the temple, and that there may still be most important remains built up in walls. Excavations on a very extensive scale have also been conducted by Sir Charles Warren in 1867-70, Major Conder in 1871-76, Clermont Ganneau in 1874-75, the Russians, the French, and the Germans; so that since 1870 the whole of the previous literature in Jerusalem topography has become completely antiquated. In the 'Jerusalem' volume of the *Survey of Western Palestine* the authors, Warren and Conder, have enumerated most of the monuments that now exist above ground or have been discovered under ground. They are briefly as follows:

- (1) The rock scarps on the south of Zion, which were almost certainly those of the first wall, and therefore belong to the time of David.
- (2) The tomb, west of the rotunda of the Holy Sepulchre Church, known as that of Nicodemus. Its form is that of the oldest class of Jewish tombs. If the site was formerly within the second wall this must have been the Tombs of the Kings.
- (3) The great rock-cut passage from the Virgin's Fount to the Pool of Siloam. This can hardly be more recent than the 8th century B.C. The inscription discovered there in August 1880 is believed from the form of the letters and the character of the language to belong to that period.
- (4) The wall of Ophel, discovered by Sir C. Warren (1868-69).
- (5) The rock scarp of the Tower of Baris. This is most probably that scarp now existing at the N.W. angle of the Haram.
- (6) The rock-cut monuments in the Kedron valley. Many belong apparently to the Hasmonean period (2d c. B.C.).
- (7) The Haram area itself, the site of the temple, with its stupendous walls, its ancient gates, its wailing-place, and the buildings within it; the Mosque el-Aksa, the Dome of the Rock, the Dome of the Chain, the Golden Gate, its vast vaults, hitherto but little explored.
- (8) The Pool Amygdalon, now called Hezekiah's Pool. This is probably as old as Herod.
- (9) The Pool of Bethesda, recovered in 1888.
- (10) The Twin Pool, half of which was found by Wilson in 1866, and the other half by Warren in 1868.
- (11) The Tower of David, which is certainly on the site of one of the old royal towers, probably Phasaelus.
- (12) The Tyropœon Bridge, marked by the spring of the first arch. The remains of that arch and the opposite pier were discovered sixty feet under ground by Warren in 1868.
- (13) The wall erected by Hadrian to fortify his Elia Capitolina. This probably followed the line of the present city wall. He also probably made the great reservoir, Birket Israel.
- (14) The Basilica of the Anastasis, completed by Constantine in the year 335 A.D., certainly stood on the site of the present church of the Holy Sepulchre. It was entirely destroyed by Chosroes II in 614 A.D. There are, however, still existing certain remains and fragments which have been fitted by Conder into their places in Constantine's work. After the destruction of this building a more humble group of churches was erected on the site.
- (15) In the year 532 A.D. Justinian built the great Basilica of St. Mary's within the temple area. This church is probably the present Mosque el-Aksa. It is suggested by Conder that the later ornamentation of the Double Gate, the structure of the Golden Gate, and the roofing of the Haram eastern also belong to the time of Justinian.
- (16) The existing church of the Holy Sepulchre was commenced in 1103 A.D. and stood until 1808, when it was partly destroyed by fire. Some parts of it are, however, believed to be older than the crusaders' time.
- (17) The great Hospice of the Knights of St. John, south of the Holy Sepulchre, was erected during the Latin kingdom.

Recent excavations (1875-85) have laid bare a great part of these buildings.

- (18) Of crissading remains there are still many in the city. The Tower of David on the site of Phasaclius (?) is mainly the work of the Pisans, and a great deal of the city wall is of crissading times.

These are the principal monuments now existing. We may add the discovery in 1887 of a fragment of what was certainly part of the second wall, certain rock scarpings which are supposed to belong to the same wall, and a wall with a gate discovered in the building of the Protestant church, which has been conjectured to belong to this wall. But this is uncertain, as the course of the wall has never been clearly ascertained.

The Restoration of the City.—The restoration of the ancient city, whether under Herod or Solomon, has been the subject of keen controversy for many years. It is, of course, perfectly well known that to the ordinary pilgrim every spot in the city connected with the Sacred Narrative is exactly ascertained. He has no doubt. The first who ventured to dissent from the authority of tradition and the priests was one Korte, a German printer, who travelled in Palestine about the year 1728. There, however, a hundred years later, he was followed by Dr Robinson, who argued that the church of the Holy Sepulchre could not possibly cover the site of our Lord's tomb. In the year 1847 Mr James Fergusson, a well-known student of Indian architecture, produced an essay on the topography of Jerusalem, in which he advanced the proposition that the Dome of the Rock was not built by Melek at all, but by Constantine, that it covered the Holy Sepulchre, that the site had been transferred at some time or other—during some period of disturbance—that the temple was not built over the 'Rock,' but in the south-west corner of the Haram. These revolutionary views were adopted by a small party, and even advanced in Smith's *Dictionary of the Bible*. Since that time the opinion has also been advanced further that Mount Zion and the city of David were not the upper but the lower hill, and that the latter was situated on the northern slope of Ophel. These views, of course, necessitated a complete re-casting of the topography, with results that have been, with various modifications, before the world for forty years. As regards the general acceptance of these theories it is enough to say that Warren, the explorer of Jerusalem, and Conder, the surveyor of western Palestine; that Palmer and Le Strange among linguists; that De Vogué, George Williams, Willis, Clermont Ganneau, among antiquaries and scholars; with many other scholars, all alike refuse to accept them; and that not a single architect of eminence has followed Fergusson's views as to the date of the Dome of the Rock.

The sites adopted in this article are those advocated by Warren and Conder, who agree in the main points. The reasons will be briefly indicated.

(1) *The Site of the Temple.*—It was within the Haram area, which is defined by the ruins of its gigantic walls: Josephus says that the cloisters reached from 'valley to valley'; that the wall of Ophel joined the east cloister; that the temple was on the top of the hill; that the Tower of Antonia stood on a lofty rock north of the hill. Not one of these conditions can be satisfied by Fergusson's view, which places the temple in the south-west corner of the Haram and makes the east wall start northwards 600 feet from the south-west corner and on the level part of the ridge. This theory was put forward before any excavations had been attempted and when the nature of the ground was utterly unknown. The hill has now been contoured, and it seems certain that if Josephus was right the temple stood over the sacred rock, which, according to De Vogué, was just south, and

according to Warren, was just north, of the altar. The latter also makes it the foundation of the gate Nitzotz. Conder, on the other hand, identifies the rock, which is the highest point of the hill, with the foundation-stone of the Holy House. He therefore follows Josephus exactly. Not only this: he follows a tradition accepted universally by Jew, Christian, and Moslem. Now it is a maxim based on the experience of this officer, who has given far more time and attention to this subject than any other traveller or scholar, that when a tradition is accepted by all alike it is generally true. From every other consideration, indeed, Conder's views seem impregnable. If Solomon built his temple where Fergusson put it, he either built it half-way down the hill and on a steep slope, or he had to make enormous sub-structures to begin with: he chose for his site a hill with a slope of 1 in 5; he neglected the obvious advantages of the summit; and he departed from the universal custom of choosing the highest part of the hill for temple, fortress, or city. As regards the position of Antonia, that agrees perfectly with the rock scarpings now known to exist at the north-east of the Haram area and with Josephus. Further, if the temple had been built at the south-west corner there would have been a break in the continuity of the wall at a point 600 feet east of the south-west angle—that is, at the Double Gate. No such break occurs, and no trace of foundations remains where the east wall of the temple would have stood. The whole of the walls about the Haram have been examined at different points; they all belong to the same period, and were built by the same builder. But, it is argued, Josephus says that the temple enclosure was a stadium in length on each side. Fergusson began, therefore, by measuring out a space of 600 feet. Why Josephus should in one place be considered as accurate as a modern engineer and in all other places should be acknowledged as a loose and inaccurate writer is not apparent. Conder, however, and those who agree with him meet the difficulty by supposing (as the Mishnah also does) that the sacred enclosure, *estimated, not measured*, by Josephus, meant the sacred court within which no Gentile could enter. (See Warren and Conder's *Jerusalem*.)

(2) *The Site of the Holy Sepulchre.*—This site is even more important on topographical grounds than the exact position of the temple. For on it depends the course of the second wall. On other grounds it is important, because the whole question of tradition and its value depends upon it. If we can prove that the second wall runs without the church, then Christ could never have been buried here, and the whole mass of medieval traditions comes toppling to the ground, dragging with them a thousand superstitious and traditions attached to other places. Fergusson says that the Dome of the Rock is the actual church built by Constantine. Now this church was certainly destroyed by Hakém. Further, if our view of the temple be correct, the church could not have stood on this site. But against Fergusson's view every single writer, every pilgrim and traveller, and every architect is arrayed. There exists a long *catena* of evidence from the Bordeaux pilgrim of the 4th century to the present day, which, when it is arranged in chronological order, makes it impossible to doubt that the basilica erected by Constantine was on the site of the present church.

Was, however, the true site of the Holy Sepulchre known to the Christians of that time? The present writer agrees with those who believe that in the 4th century the site of the Holy Sepulchre was utterly lost and forgotten. There is not a hint anywhere to show that it was known or cared about. No tradition of it survived. When

pilgrims first began to visit the city they were shown the site of the Ascension; it was the living Lord they worshipped, not the dead Christ. As for the tomb itself, they never so much as inquired after it. When sites began to be manufactured this would doubtless be one of the first, and Eusebius with naïveté records the surprise of everybody when they dug up the ground covering what they called the site of the Lord's tomb, and actually did find a tomb there! The difficulty of a transference of sites—though sites are sometimes transferred—is enormously increased in this case, because there never ceased, during the time, when the transference was possible, a continuous stream, first, of Christian pilgrims, including clerics as well as ignorant people, and next, of Moslem pilgrims; and in order to gain evidence for their story, the Christians who changed the site would have to get the Moslems to join in the fraud. And how was the memory of the old site to be obliterated from the minds of the people?

There are many other questions connected with the topography of the city, such as the apparent confusion of Mount Zion, sometimes with the city of David, and sometimes with the temple; the description of the city given in the Book of Nehemiah; the date and purpose of the Golden Gate; the position of the gates of the city; the course of the first, second, and third walls; the royal towers; the Tombs of the Kings, with many others which must be left for a more detailed investigation. Meantime, to fix the site of the temple, Antonia, the first and second walls, and the Basilica of the Anastasis is to go far towards clearing up the whole of this difficult question connected with the recovery of Jerusalem.

Modern Jerusalem.—The present city contains about 48,000 inhabitants, of whom half are Jews, a quarter Moslems, and the rest Christians of various sects. There are three sects of Jews, the Sephardim, of Spanish origin; the Ashkenazim, of German or Polish origin, themselves divided into several sects; and the Karaites. The Christians consist of Greeks, Armenians, Georgians, Copts, Syrians, Abyssinians, Latins, and Protestants. Lying among not very fertile mountains, the city has but little commerce, and practically no manufactures; of late years it has grown a considerable way outside its walls, the dull, uniform, windowless one-storied houses stretching on every side. The climate has been compared to that of the south of France. Snow sometimes falls in January and February; rains begin in October and continue to fall at intervals till April, when a cloudless sky begins and lasts until October. There are now banks and hotels, and a railway from Jaffa was opened in August 1892.

The best books on Jerusalem are De Vogüé's *Temple de Jérusalem*; Warren and Conder's *Jerusalem* (Palestine Exploration Fund), with its great portfolio of plates (1884); Wilson's *Ordinance Survey of Jerusalem* (1868). The student should also consult the *Quarterly Statement of the Palestine Exploration Fund*, for which a very good index has been made. *Palestine under the Moslems* (1890), by Guy le Strange (Palestine Exploration Fund), is invaluable because it is the only book which gives the evidence of Arabic writers. Major Conder's *Tent Work in Palestine* (1878) also contains an excellent chapter on Jerusalem. And for architecture there is the work (1888) of Professor Hayter Lewis on the Dome of the Rock. See also Besant and Palmer, *Jerusalem, the City of David and Saladin* (1872; 4th ed. 1899); and the articles CALVARY, JEWS, MACCABEES, CRUSADES, GODFREY, BALDWIN, HOSPITALIERS, OMAR.

JERUSALEM BISHOPRIC.—In 1841, at the instance of Frederick William IV. of Prussia and by the mediation of Count Bunsen, an arrangement was made to institute a bishopric at Jerusalem in connection with the united Church of England and

Ireland, and under the joint protection of England and Prussia. The right of appointment was to lie alternately with each of the protecting governments. The agreement met with strenuous opposition on the part of the Tractarian section of the Church of England, as excluding sympathy with the Roman Catholic Church, and courting intercommunion with Protestant, non-episcopal Prussia; and Newman regarded it as 'the third blow, which finally shattered his faith in the Anglican Church.' The first bishop, Alexander, was a converted German Jew who had taken orders in the English Church. On his death (1845), Bishop Gobat, a German Swiss who had been in the service of the London Missionary Society, was appointed by Prussia. He died in 1879; and on the death of the third bishop, Barelay (named by England), in 1883, no successor was appointed. Prussia withdrew from the agreement in 1886; and since 1887 the bishopric is a missionary bishopric of the Church of England exclusively. See Hechler, *The Jerusalem Bishopric* (1883).

Jerusalem Artichoke. or TOPINAMBURO

(*Helianthus tuberosus*), a plant of the natural order Compositæ, and of the same genus with the common Sunflower (q.v.), is a native of Brazil. The word Jerusalem, in the English name, is a corruption of the Italian *girasole*, 'sunflower'; the name *artichoke* is merely from a supposed similarity of flavour in the eatable part—the tuber—to the Globe artichoke. The Jerusalem artichoke has straight, sparsely branching stems from 8 to 12 feet high, and many rough, ovate, acute stalked leaves; and in the end of autumn, though rarely in Scotland, produces yellow flowers resembling those of the common sunflower, but smaller.

The thick, fleshy, and knotted perennial root produces, pretty closely around it, oval or roundish tubers, sometimes thirty or fifty in number, which are reddish on the outside, and whitish within, in appearance very similar to potatoes. They have a sweetish, mucilaginous taste when boiled, and are much more watery and less nourishing than potatoes. They are, however, very palatable, when properly prepared with sauce, and make very good soup. The plant is also useful for fodder for cattle, yielded by its leaves and the more tender parts of the stems. The stems and leaves contain much nitre, and have been used for making potash. The fibre is used for making cordage and coarse cloth.

The Jerusalem artichoke is scarcely an agricultural crop in Britain, although it is to some extent in some parts of Europe. It was known in English gardens before the potato, to which it in some measure gave place. It is generally propagated by small tubers, or cuttings of tubers, like the potato; and its cultivation is in most respects similar, although the aspect of the plant is very different. In America it is sometimes called Canada potato or Virginia potato.



Jerusalem Artichoke
(*Helianthus tuberosus*).

Jerusalem Chamber. See WESTMINSTER.

Jervanx Abbey (pronounced *Jarris*), a ruined Cistercian abbey of Yorkshire, 13½ miles NW. of Ripon. It was built in 1156 by monks from the Yorkshire monastery of Byland, and was dismantled in 1539, its last and twenty-third abbot having been hanged two years before for his share in the Pilgrimage of Grace. Its scanty ruins were excavated in 1803 by the Earl of Ailesbury.

Jervis, SIR JOHN. See ST VINCENT (EARL).

Jesi, or **LESI** (anc. *Æsium* or *Æsis*), a walled town of Italy, 17 miles by rail SW. of Ancona, has a cathedral, a town-house with good pictures, manufactures of silk, paper, soap, &c., and a trade in wine, olive-oil, corn, and cheese. Here the Emperor Frederick II. was born. Pop. 12,118.

Jessamine. See JASMINE.

Jesse, EDWARD, a popular writer on natural history, was born at Hutton Cranswick, Yorkshire, 14th January 1780. He became clerk in a government office, and was successively secretary to Lord Dartmouth, commissioner of hackney-coaches, and deputy surveyor-general of the royal parks and palaces. He died at Brighton, 29th March 1868. His books include *Gleanings in Natural History* (1832-35), *An Angler's Rumbles* (1836), *Scenes and Tales of Country Life* (1844), *Anecdotes of Dogs* (1846), and *Lectures on Natural History* (1861); besides editions of Walton's *Complete Angler*, White's *Selborne*, and Ritchie's *Windsor Castle*. See Mrs Houston's *Sylvanus Redivivus* (Lond. 1890).

—**JOHN HENEAGE JESSE,** son of the foregoing, was born in 1815, and at an early age filled a place in the secretary's department of the Admiralty at Whitehall. He had already written poems and plays without success, when he found his work in a series of bright and interesting works in the field of domestic history, which have yet far more than their mere readableness to commend them to general readers, if not to serious students. These are *Memoirs of the Court of England during the Reign of the Stuarts* (1840), *Memoirs of the Court of London from the Revolution of 1688 to the Death of George II.* (1843), *George Selwyn and his Contemporaries* (1843-44), *Memoirs of the Pretenders and their Adherents* (1845), *Richard the Third and his Contemporaries* (1862), and *Memoirs of the Life and Reign of King George the Third* (1867), the last his best book. Other works are his *Literary and Historical Memorials of London* (1847); *London: its Celebrated Characters and Remarkable Places* (1871); and *Memoirs of Celebrated Etonians* (1875). He died 7th July 1874.

Jesse Window, a window that had the genealogical tree of Jesse, father of David, painted on its glass or sculptured on the mullions. Such were once common in churches.

Jessor, also called **KASBA,** a town of Bengal, capital of a district, 7½ miles by rail NE. of Calcutta. Pop. 8095. Since the opening of the Central Bengal Railway Jessor has developed into a trading-mart of some importance in local products.

Jest-books are of two kinds: collections of witty sayings and practical jokes which go under the names of certain men who were celebrated in their day as 'merry fellows,' and collections of fæticæ, gathered from many sources, ancient and modern. Of the first class *Tarleton's Jests* may be considered as a fair type among English books of fæticæ. Here all the jests and practical jokes are ascribed to that popular Elizabethan comedian, or rather buffoon; but probably not a single one of them is genuine or authentic. This book, in fact, is simply a catchpenny collection of jests taken out of older books, and fathered on Tarleton after his death in order to stimulate its sale and popularity.

A notable example is found in Tarleton's device to reach London without expense, at a time when he was in the country and with an empty purse: he contrived to have himself arrested as a 'seminary priest' and taken up to the metropolis, where he was at once recognised and set at liberty. This is a variant of the well-known story of Rabelais, with his three packets of harmless wood-ashes, labelled 'Poison for the King,' 'Poison for the Queen,' 'Poison for the Dauphin.' And it reappears in another jest-book of the same class, in the composition of which the learned man under whose name it goes had no more share than he had in that of the Talmud, namely, *The Witty and Entertaining Exploits of George Buchanan, commonly called the King's Fool*. Another old English book of this kind is the *Jests of Scogin*, which the enterprising printer foisted on the public—as was also done in the case of the *Tales of the Mad Men of Gotham* (see **GOTHAM**)—as having been compiled by 'A. B. of Phisicke Doctour,' meaning the facetious Andrew Borde. In this book Scogin, or Scogan, 'a scholler of Oxford,' is represented as playing all sorts of tricks, most of which are found in earlier collections, and all are traceable to French, Italian, and Asiatic sources. For example, with the help of his 'chamber-fellow,' he cheats a simple rustic out of half his flock of sheep by persuading him that they are really hogs—a trick which not only occurs in mediæval Latin collections and all the jest-books of Europe, but has its probable original in an old Indian work entitled *Hitopadesa* (a Sanskrit form of the Fables of P'lipay, or Bidpai), where, in like manner, three sharpers cheat a Brahman of a goat he is carrying to sacrifice, by making him believe it is a dog. Of other jest-books the *Pleasant Conceits of Old Hobson, the Merry Londoner*, is a good example, albeit, as usual, containing little that is not found elsewhere. Old Hobson is a confirmed practical joker, and many of his best conceits turn on merely verbal quibbles. Two more books of this class are the *Jests of George Feble*, the player, and *Archy Armstrong's Banquet of Jests*; and it is hardly necessary to say that their names are all that is theirs in the collections.

The oldest known English jest-book is *A Hundred Merry Tales* (about 1525), to which the lively Beatrice refers when she says to Benedick, in *Much Ado about Nothing* (Act II. scene I), 'Will you tell me who told you that I was disdainful, and that I had all my good wit out of the *Hundred Merry Tales*?' Next in order of date—and of interest also—is *Merry Tales, Witty Questions, and Quicke Answers, very Merry and Pleasant to be Redde* (about 1535). From these two the compilers of subsequent jest-books in the early years of the 17th century drew very freely, with one notable exception, *Taylor's Wit and Mirth* (i.e. John Taylor, the Water-poet), which, he tells us in the lengthy title-page, he 'chargeably collected out of Taverns, Ordinaries, Innes, Bowling-greenes and Alleys, Ale-houses, Tobacco shops, Highways and Water-passages,' and which is 'made up and fashioned into Clines, Bulls, Quirkos, Yerkes, Quips and Jerkes; apothegmatically bundled up at the request of John Garrett's Ghost' (1635). This is by far the most original of all our English jest-books—by which we mean that it contains very few of the tales found in the earlier collections. And if we seek for the reason of this, it is probably to be found in the superior advantages which Taylor possessed over mere literary hacks who were able only 'to make new books as apothecaries make new mixtures, by pouring out of one vessel into another'—in his profession of a Thames waterman, which must have brought him into contact with all sorts and conditions of men, from whom, more especially

sea-captains, he probably learned a goodly portion of the jests he tells so quaintly.

The earliest collections are largely derived from classical and monkish sources, and some of the tales are exceedingly coarse, even obscene. Many are at the expense of the monks and friars, whose greed and licentiousness are the subjects of unsparring ridicule. Not a few exhibit women in no very favourable light, whether maids or matrons, and these we may be sure are the invention of misogynist clergymen. Such tales show that women were held in almost as low estimation in Europe during the middle ages, and long after, as they seem ever to have been in Asiatic countries; and there can be little doubt that this was due mainly to the monks and friars, for whom our own Chaucer had seldom a good word to say. There is, however, considerable humour in some of these tales at the expense of women; and, after all, human nature is very much the same in every age and place: as, for example, in the story of the young woman who grieved for the death of her husband, and her father tried in vain to console her by saying that he had got her another husband, but she declared she would have him not; however, when they were all seated at dinner, she whispered to him, amidst her sobs, 'Father, where is this same young man that is to be my husband?' To which the story-teller adds the 'moral' that 'by this ye may see that it is no more wonder for a woman to weep than for a goose to go barefoot.'

The best known of English collections of facetiæ is *Joe Miller's Jest-Book, or the Wit's Vale Mecum*, which, even in its original form (1739), is a mere compilation of witti-i-isms, drawn by the versatile John Mottley mainly from 16th and 17th century jest-books, the best joke in it being the name of Joseph Miller (1684-1738) on the title-page; for, though a comedian by profession, it is said that he was never known to make a joke in his life. Those who are well acquainted with the humorous literature of other countries as well as that of our own must confess that if our jest-books, both ancient and modern, were stripped of all that is borrowed, the number of jokes that we can fairly claim would be exceedingly few indeed. But, for the matter of that, no other country is better. The late Mr Radston has justly remarked that 'an unfamiliar jest is rarely met with in the lower strata of fiction.' The best jokes have been for ages known alike to the Russian or Norwegian peasant, the vine-dresser of France or Spain, the Italian rustic, the Argyllshire crofter, the wandering Arab, the luxurious Persian, the peaceful Hindu, and the crafty Chinese. We pass over the species of mountebank jest which has of late years come into vogue in the corners of many American newspapers, as it is likely soon to perish of its own infirmities. Most of the early English jest-books mentioned in this article are now, in their original forms, of extreme rarity, although there must have been many and large editions of them. Mr W. C. Hazlitt—who has reprinted a considerable number of them in his *Shakespeare Jest Books* (3 vols. 1864), with valuable prefaces and notes—thinks that they were literally 'thumbed out of existence;' but this can hardly account for their exceeding rarity, and we are rather disposed to believe that vast numbers of copies were destroyed during the Puritanical times along with much more valuable books; and, when the reaction set in with the Restoration, they would be considered as old-fashioned, and the wits would begin afresh, though they did not disdain to make a very liberal use of the antiquated jest-books.

Besides the books already incidentally mentioned, most collections of folklore and of chap-books contain jests,

Again, many books of this class are roughly grouped as 'Facetiæ' in booksellers' lists, especially if more or less *grovianis* in character. Good English jest-books of the Cavalier period are the *Westminster Droollery, Choice Droollery*, and *Merry Droollery*, reprinted by Mr R. Roberts of Boston (3 vols.). See articles BIDPAL, CHAP-BOOKS, FOLKLORE, and GOTHAM.

Jesters. COURT, persons who were kept in the households of princes and lesser dignitaries to furnish amusement by their real or affected folly, and hence commonly called Court Fools. At what time they were introduced into European courts has not been precisely ascertained, but there is reason to suppose that they existed in England during the period of our Saxon history, and certainly in the reign of William the Conqueror, since an almost contemporary historian, Maitre Wace, has left a curious account of the preservation of William's life, when he was only Duke of Normandy, by his fool Godes. Other fools whose names have descended are the Hitard of Edmund Ironside, the Will Somers of Henry VIII., Archie Armstrong, who lost his office for jests which the petty-minded Laud could not endure; and in France Caillet and Triboulet in the time of Francis I., and Chicot in the reign of Henry III. Triboulet figures in Rabelais, and is the hero of Hugo's *Le roi s'amuse* and of Verdi's *Rigoletto*. The last private person to keep a fool in England was Lord Suffolk, whose jester, Dicky Pierce, was buried at Berkeley in 1728. In Douce's *Illustrations of Shakespeare* (1897) there is a dissertation on clowns and fools, with an account of their peculiar dress, the motley coat, the tight breeches with legs of different colours, the cowl bearing asses' ears and crested with a cockscomb, and the bauble, a short staff with a ridiculous head. Douce divides them into nine classes, and finds the parent of the Shakespearean stage clown in the 'vice' of the mysteries and moralities.

In the East the office of jester existed in the 8th century, and probably much earlier in India. The famous Calif Haroun al-Raschid had a jester named Bahalul, some of whose sayings and doings have been preserved by Arabian writers. He appears to have possessed vivacity, wit, and observation, which were, however, often concealed under a mask of simplicity, and he was permitted to take great liberties with the calif's courtiers. 'I wish,' said Haroun to him one day, 'I wish you would proemre me a list of all the fools in Bagdad.' 'That would be difficult, O Commander of the Faithful,' replied the jester; 'but if you desire to know the wise men, the catalogue may soon be completed.' This found its way—*mutatis mutandis*—into English jest-books in the 16th century. One day Bahalul was discovered seated on the calif's throne, for which Haroun awarded him a whipping; then said the jester, 'O Commander of the Faithful, I sat in this seat only half an hour and have been whipped for doing so; what do you deserve who sit in it every day?' The jester doubtless thought the slight scourging he received was amply compensated by the bag of gold pieces which Haroun ordered to be given to him for his witty remark.

From the practical jokes popularly ascribed to Ramakistnan, he may be styled the Scogin of Madras. A collection of his jests in the Tamil language was translated into English and Telugu by Narrain Sawmy, and published at Madras in 1839, and not a few of them are almost identical with tales ascribed to European court jesters, such as our English Scogin and the Italian Gonella. This almost unknown little book explains how he was endowed with so much wit that he became the greatest jester in the world, and by the exercise of this wit at the court of a rājā, was able to maintain himself and family. Like the European court

jesters, Rannakistnan's too ready wit frequently roused his royal master's wrath; but though sometimes condemned to death he always evaded it, and was again and again received with favour through his irresistible drollery. His jests, however, have none of the coarseness which is the chief characteristic of his western brethren; for example, in his counterpart to the well-known jest of Scogin, when the king commanded him never to show his face in the royal presence again, he saves propriety and carries out his jest by entering with a large pot over his head and down to his shoulders. See Dr Doran's *History of Court Fools* (1858).

Jesuits, or SOCIETY OF JESUS, a celebrated religious order of the Roman Catholic Church, which has filled a large space in the ecclesiastical and even the political history of the world. It was founded in 1534 by Ignatius Loyola (q.v.), in concert with five associates—Peter Le Fevre, a Savoyard; three Spaniards—James Lainez, Francis Xavier, and Nicholas Bobadilla; and a Portuguese named Rodriguez. The original object of association was limited to a pilgrimage to the Holy Land, and a mission for the conversion of infidels; but as all access to the Holy Land was precluded by the outbreak of a war with the Turks, the associates turned their thoughts to a more comprehensive organisation, specially designed to meet those more modern requirements which had arisen since the Reformation. With this view, Ignatius Loyola, with Lainez and Le Fevre, having meanwhile recruited several new associates, repaired to Rome in 1539, and submitted to the pope, Paul III., the rule of the proposed order, the great aim of which was expressed in their adopted motto: *Ad Maiorem Dei Gloriam* ('To the greater glory of God'); and the vow of which, in addition to the threefold obligations common to all Catholic religious orders, of chastity, poverty, and obedience, comprised a fourth, whereby the members bound themselves unreservedly to go as missionaries to any country which the pope might indicate to them. The new rule was approved by a bull of 1540; and in the following year the association was practically inaugurated at Rome, by the election of Ignatius Loyola as its first general.

The original constitution of the society has undergone few modifications. Although it is commonly represented as absolutely monarchical, yet the authority of the general is, in many respects, strictly limited. It is true that the general—who is elected by a congregation of professed members, composed of two elected fathers in each province together with the provincial—holds his office for life; and, although he is aided in his government by a council of five assistants, he is not obliged to follow their advice even when unanimous. These assistants are elected by the same congregation that elects the general, and remain in office during his life. Each assistant has a more immediate charge of a group of provinces and missions called an *Assistance*, formed mainly according to the principal European languages—Italian, German, French, Spanish, and English. But though the general is thus absolutely free in his decisions, he is strictly bound by the constitutions of the order; nor, although he may dispense in particular cases, is he competent of his own authority to annul or to alter any of the constitutions. Another check on merely arbitrary power and outlet for complaints may be mentioned. Every three years a Congregation of Procurators, as it is called, is summoned by the general. This is composed of a deputy chosen by vote in each province to go to Rome or elsewhere, and lay the condition and needs of the province personally before the general. When all the deputies are assembled, they have under the presidency of the general always to vote

on and decide one question—whether there is any need of convoking a general congregation. Although no instance of deposition has ever occurred, the general himself is liable to be deposed by the sentence of such a general congregation, in certain contingencies which are specifically pointed out by the constitutions.

The body over which this general presides consists of four classes: (1) Professed, who, having passed through all preparatory stages, which commonly extend over ten or twelve years, or even a longer period, have solemnly taken the vows described above, including that of obedience to the pope. It is from this class alone that the general and all the higher officials of the society are chosen. (2) Coadjutors, spiritual and temporal; the former—who have completed their studies, and have (seldom before their thirty-second year, or even later) been admitted to holy orders—being designed to assist the professed in preaching, teaching, and the direction of souls; the latter being lay-brothers, to whom the minor and menial offices of the society are assigned. (3) Scholastics, who, having passed through the novitiate, are engaged for a long series of years, either in pursuing their own studies, or in teaching in the various schools of the order. (4) Lastly, novices, who, after a short trial as 'postulants' for admission, are engaged for two years exclusively in spiritual exercises, prayer, meditation, ascetic reading, or ascetic practices, and generally in a course of disciplinary training. The administrative and executive government of the society, throughout the various provinces or missions into which it is divided, is entrusted, under the general, to provincials, who are named by the general, and hold office commonly for at least three years. In each separate province there are three kinds of communities—professed houses or residences, colleges, and novitiates. The head-superior in each is appointed by the general, who receives at stated intervals a detailed report of the character, conduct, and position of each member of the society. In all these gradations the subordination is complete, and the obligation of obedience is immediate and unreserved; and one of the most familiar accusations against the society is that this duty of blind and implicit obedience makes the superior the sole and final arbiter of conscience for all his subjects, the judge of good and evil, of virtue and of vice. Nevertheless, whatever may be said of the practical tendency of this relation, the Jesuits and their apologists plead that both in the rules of St Ignatius and in the so-called 'examen' of the candidate there is contained, in the duty of obedience to a superior, an explicit reservation for the subject, 'unless where the superior should command what is sinful.'

The system of training exhibits the most profound knowledge of the human heart, and the most correct appreciation of the religious instincts and impulses of mankind. The long exercises of the novitiate were designed by Ignatius to form the individual character in habits of personal holiness, and practices of personal piety. It was the business of the school and college to form the social character of the future teachers of men, and directors of the destinies of society. To learning carefully adapted to the actual condition and progress of knowledge they sought to add manners and habits calculated to inspire confidence, and to disarm prejudice and suspicion. Unlike the older orders, they made no parade of a special calling, whether by a peculiar habit, or by peculiar exterior indications of austerity or asceticism. They enjoyed, indeed, in these respects, some exemptions from the more austere practices of other orders. Their churches were but designed as supplementary

to those of the parish clergy (whose ordinary costume they adopted as their own conventional dress), without the canonical services, without much imposing or attractive ceremonial; being chiefly appropriated for religious instruction, and for the duties of the confessional. Their casuistry avoided all harsh and excessive rigour; and it cannot be doubted that some of their writers carried it to the opposite extreme. But above all, they addressed themselves to the great want of their time—education; and through the mastery which they soon obtained in this important field, as well as their eminence in every department of learning, divinity, philosophy, history, scholarship, antiquities, and letters, they attained to unbounded influence in every department of society.

The organisation of the society is settled, in every important particular, by the original rules and constitutions of St Ignatius. The opponents of the Jesuits, however, allege that, in addition to these public and avowed constitutions, there exists in the society, for the guidance of their hidden actions, and for the private direction of the thoroughly initiated members, a secret code, entitled *Monita Secreta* ('Secret Instructions'), which was meant to be reserved solely for the private guidance of the more advanced members, and which was not only not to be communicated to the general body, but was to be boldly repudiated by all should its existence at any time be suspected or discovered. This singular code, a masterpiece of craft and duplicity, was first printed at Cracow in 1612, and has been repeatedly reprinted by the enemies of the Jesuits; but it is indignantly disclaimed by the society. The accounts of the time and circumstances of its discovery are suspicious and contradictory. The book has been repeatedly condemned, both at Rome and by other authorities, as well as by the society, and its apocryphal character is now commonly admitted.

The history of the society is varied in the different countries, but in each may be divided into three stages—the rise, the suppression, and the restoration of the order. In Italy its early career was brilliant and unclouded. Before the death of the first general, St Ignatius, in 1556, the Italian Jesuits had swelled to 1000 in number, and the order was established in twelve provinces. Their first check in Italy occurred in Venice. In the contest of this republic with Paul V. (q.v.) the Jesuits, taking the side of Rome, accepted in 1606 the alternative, proposed by the senate, of leaving the Venetian territory; nor was it till 1656 that they were re-established in Venice, from which time they continued to enjoy undisturbed influence in Italy until the suppression of the order. The earliest settlements outside of Italy were in Portugal and Spain. In 1540 Rodriguez (a Portuguese nobleman) and Francis Xavier opened colleges in Portugal, at the invitation of the king. Francis Borgia, Duke of Gandia, in Spain, was equally well received in his native country, where the order flourished so rapidly, that, at the time of the suppression, the Spanish Jesuits numbered above 6000.

In France, although a house for novices was founded in Paris by St Ignatius in 1542, the university of Paris opposed their introduction as unnecessary, and irreconcilable with its privileges. They were distasteful to supporters of the Gallican liberties, and still more to the Huguenots. The jurists, the parliament, and the partisans of absolutism were alarmed by the free political opinions which had found expression in some of the Jesuit schools. On the other hand, the democratic party attributed to them a sinister use of their influence with courts. And thus their progress in France was slow, and their position at all times precarious. It was with much difficulty that the parliament of

Paris consented to register the royal decree which authorised their establishment. In more than one instance the university protested against their schools as invading its privileges. In the wars of the League they did not fail to make new enemies; and at length the assassination of Henry III. by Clement (although no evidence of any connection with the Jesuits appeared in his case), and the circumstance that Chatel, who attempted the life of Henry IV., had at one time been a pupil in their schools, led to their expulsion from France in 1594. They were reinstated, however, in 1603; but on the assassination of Henry IV. by Ravaillac the outcry against them was renewed. Although it seems quite certain that this clamour was utterly without foundation, yet the opinions held by one of their order, Mariana (q.v.), on the right of revolt, although condemned by the general, gave a colour to this and every similar imputation. A less deep but more permanent and formidable movement against them was gradually stirred up at a later period, by a combination of all the causes of unpopularity already described, to which new point was given by the well-known Jansenist controversy, and by the questions as to the imputed laxity of the moral teaching of the Jesuits, and their alleged corrupt and demoralising casuistry. What the ponderous and indignant prelections of the Sorbonne, and the learned folios of the Dominican and Augustinian schools had failed to accomplish, the wit and brilliancy of the celebrated *Lettres Provinciales* of Pascal (q.v.) effectually achieved. The laxity of some of the Jesuit casuists was mercilessly exposed by this brilliant adversary, who represented it as the authorised teaching of the order, and the crafty maxims and practices popularly ascribed to the society were placed before the world in a light at once exquisitely amusing and fatal to the reputation of the body. The attempts at rejoinder on the part of the Jesuits but served to fix the ridicule more firmly. Of the thousands who laughed at the happy humour, or sympathised with the vigorous railery of Pascal, few, indeed, could plod through the learned but heavy scholasticism of his adversaries. In vain the Jesuits insisted that the obnoxious casuists had been condemned by the society itself; in vain they showed where their opinions differed from those imputed to them. The wit of Pascal remained unanswered; and whatever were the logical merits of the controversy, no doubt could be entertained as to its popular issue. The pungent pleasantries, too, of the *Provincial Letters* were but a foretaste of the acrimony of the later Jansenistical controversies, in which the Jesuits stored up for themselves an accumulation of animosities in the most various quarters, the divines, the lawyers, the courtiers, which were destined to bear bitter fruit in the later history of the society in France. Nevertheless, after a long conflict, they enjoyed a temporary triumph in the last years of the Regency and the beginning of the reign of Louis XV.

In Germany the Jesuit institute was received with general and immediate favour. In the Catholic territories, Austria, Bavaria, and the Rhenish principalities, they not only founded colleges and other establishments of their own, but they were appointed at Ingolstadt and other universities to hold important professorships, and received in many dioceses the charge of the episcopal seminaries then newly established. Before the death of the first general, St Ignatius, the order could reckon in Germany 26 colleges and 10 professed houses. In Hungary and Transylvania much bitterness arose out of their introduction; the same may be said of Bohemia and Moravia; and through the whole course of the Thirty Years' War the Jesuits, though in many instances wrongfully,

were regarded by the belligerent Protestants as the soul and centre of the Catholic camp.

In the Netherlands they encountered some opposition at first; but in 1562 Lainez, the second general of the order, came to the Low Countries, and a college was opened at Louvain, which eventually became one of the greatest colleges of the order. In the Protestant kingdoms the Jesuits obtained entrance only as missionaries, and in some, as in England, Scotland, and Ireland, under circumstances of great difficulty and peril. From England they were excluded by the penal laws under pain of death; nevertheless, with a constancy and devotedness which it is impossible not to admire, they maintained through the worst times an unbroken succession of missionaries in many parts of England. They often resorted to the most singular disguises, and generally bore false names; and several of the old Roman Catholic mansions still show the 'Priest-hole,' which was contrived as a retreat for them in cases of sudden emergency. Into Ireland they effected an entrance almost at the first foundation, and, after many vicissitudes, towards the close of the reign of Charles II. they had more than one considerable college for the education of youth.

But a still more fertile field for the enterprise of the order was that of the missions to the heathen, in which they outstripped all the older orders in the church. In the Portuguese colonies of India the successes of Francis Xavier (q.v.) are well known. The results of their missions in China (under such men as Ricci, 1552-1610, and Schall, 1591-1669) and Japan were even more extraordinary, as also in Northern and Central America. Above all, their establishments in the southern continent, in Brazil, in Paraguay and Uruguay, upon the Pacific coast, in California, and the Philippine Islands were missions of civilisation as much as of religion.

Such was this association in the first stage of its history. At their first centenary jubilee the members already numbered 13,112, distributed over 32 provinces. At their suppression, a century later, they had increased to 22,589, and were possessed of 24 professed houses, 669 colleges, 176 seminaries, 61 novitiates, 335 residences, and 275 missionary stations in infidel countries or in the Protestant states of Europe.

The decline in the fortunes of the Jesuits was rapid and decisive in its consummation. The first blow which they sustained was in Portugal. An exchange of colonial territory having been effected between that kingdom and the crown of Spain, the so-called 'Reductions' of Paragnay (q.v.), in which the Jesuit missionaries possessed an authority all but sovereign, were transferred to Portugal. The native Indians having resisted this transfer, the Portuguese ascribed their disaffection to the Jesuit missionaries. The Portuguese minister, Pombal de Carvalho, to whom the Jesuits allege that their possessions in Portugal had long been an object of desire, instituted a commission of inquiry; and while it was still pending, an attempt on the life of the king, Joseph, which was laid to the charge of the Jesuits, furnished him with a fresh ground of impeachment; and, without awaiting any judicial proof of either accusation, he issued, in September 1759, a royal decree, by which the order was expelled from the kingdom. This example was followed in other kingdoms. In France, under the Duc de Choiseul, the immediate occasion of the disgrace of the Jesuits was a trial in the civil courts. Father Lavalette, as procurator of the order in Martinique, had consigned to a commercial house in Marseilles two valuable cargoes, which were seized by English cruisers, and, Lavalette being unable to meet the bills, the Marseilles merchants proceeded

successfully against the order. The Jesuits replied that Lavalette acted not only without the authority of the order, but against its positive constitutions, and appealed to the parliament of Paris against the sentence. The inquiry thus raised presented an opportunity of which the ancient enemies of the order in the parliament eagerly availed themselves. A report on the constitutions of the society, highly denunciatory, was speedily drawn up, and a demand was made for the suppression of the order, as being irreconcilable, in its constitution and practice, with the interests of the state and of society. A strong effort was made to arrest the proceeding; but a powerful court-faction, aided by the secret influence of the royal mistress, Madame de Pompadour, who was irritated by the refusal of her Jesuit confessor to grant her absolution unless on condition of her separating from the king, and supported in the press by the philosophic party, carried all voices, public and private, against the Jesuits. An attempt at compromise was proposed to the general, Father Ricci, by which the obnoxious constitutions might be abolished or modified; but his unbending reply, 'Sint ut snnt, aut non sint' ('Let them be as they are, or let them cease to exist'), cut short all negotiation; and a royal edict was published in 1764, by which the society was suppressed in the French territory. This example was followed by Spain, in 1767, with circumstances of great harshness and severity; and by the minor Bourbon courts of Naples, Parma, and Modena. The court of Rome had zealously but vainly interposed in their behalf, and from Clement XIII., especially, they received earnest support. But his successor, Clement XIV., inclining in this and all other questions of church and state to the side of peace, having in vain endeavoured to procure from the courts by which they were condemned a relaxation of their severity, and being pressed by the ambassadors of France and Spain, at length issued, July 21, 1773, the celebrated bull 'Dominus ac Redemptor Noster,' by which, without adopting the charges made against the society, or entering in any way into the question of their justice, acting solely on the motive of 'the peace of the church,' he suppressed the society in all the states of Christendom. The bull was put into execution without delay. In Spain and Portugal alone the members of the society were driven into exile. In other Catholic countries they were permitted to remain as individuals engaged in the ministry or in literary occupations; and in two kingdoms, Prussia under Frederick the Great, and Russia under Catharine, they were even permitted to retain a quasi-corporate existence as a society for education.

What was meant, however, to be the suppression of the society proved but a temporary suspension. The ex-members continued in large numbers, especially in the Papal States and Northern Italy; and soon after the first storm of the Revolution had blown over measures began to be taken for the restoration of the society. The first overt reorganisation of them, barely tolerated by the pope, was in 1799, by the Duke of Parma; in 1801 Pius VII. permitted the re-establishment of the society in Lithuania and White Russia, and with still more formality in Sicily in the year 1804. It was not, however, until after the French Restoration, and the return of Pius VII. from captivity, that the complete rehabilitation of the Jesuit order was effected, by the publication of the bull 'Solicitudo Omnium Ecclesiarum,' August 7, 1814; and in 1824 their ancient college, the Collegio Romano, was restored to them. Once thus re-established by Pius VII., the Jesuit order as a religious order has remained on in the Catholic Church. But in different kingdoms of Europe it has had various fortunes. In Modena, Sardinia, and Naples it was re-established

in 1815, as also in Spain. It was again suppressed in Spain from 1820 to 1825, from 1835 to 1844, from 1854 to 1858, and its members were banished once more in 1868. In Portugal they have never obtained a firm footing. Their position in France was one of sufferance rather than of positive authorisation; nevertheless, they were very numerous and influential, and their educational institutions held the highest rank. In 1880, however, the republic decreed the dissolution of the order, without giving it the alternative of seeking authorisation; and in July of that year the members were expelled from all their establishments save the educational, an additional month being allowed them for vacating the latter. In Belgium they reinstated themselves after the Revolution, and they now possess many great establishments, professed houses as well as colleges, which are largely attended both by Belgians and foreigners. In Holland also they possess several considerable houses, as well as in England, Ireland, the United States, and, within a recent period, Scotland. In Switzerland they opened in 1818 a college at Freiburg, which became a most flourishing establishment, and subsequently they extended themselves to Schwyz and Lucerne; but the war of the Sonderbund (one of the main causes of which arose out of the Jesuit question) ended in their expulsion from the Swiss territory. Of the German states Bavaria and Austria tolerated their re-establishment for educational purposes. In the Italian provinces of the former, as also in the Tyrol, they enjoyed a certain freedom until the revolution of 1848. In Russia they were placed under sharp restrictions in 1817; and in 1820, in consequence of their successful efforts at proselytism, they were banished by a final ukase from the Russian territory, whence they still remain excluded. The Italian revolution of 1848 seriously affected their position in that country. In that year Pius IX. found it expedient to permit the breaking up of the college and other houses in Rome. They returned, however, with the pope himself, and resumed possession of their ancient establishments. On the proclamation of the kingdom of Italy they withdrew from Sardinia, Naples, Sicily, and the annexed territories in general. In the recent legislation of the kingdom of Italy the Jesuits have been visited with a special measure of repression. While each of the other principal religious orders is permitted to retain its 'mother house' at Rome, in which the general of the order may reside, the Jesuits have been required to quit their principal convent of the Gesu. In Germany also they have been treated with exceptional severity, being held responsible as the main agents and advisers of the measures adopted in the Vatican Council, which were complained of by the government as infringing the rights of the state. By a law of 1873 the order was excluded from the empire, its establishments were abolished, and all foreign Jesuits were ordered to be expelled, and the German members of the society, as well as of kindred orders and congregations, to be 'interned.'

The twenty-four generals of the Society of Jesus have been the following (Italians, except where otherwise specified): Loyola (1541-56), Spaniard; Lainez (1558-65), Spaniard; Borzia (1565-72), Spaniard; Mercurian (1573-80), Belgian; Acquaviva (1581-1615); Vitelleschi (1615-45); Carafra (1616-49); Piccolomini (1649-51); Gottofredi (1652); Nickel (1652-64), German; Oliva (1661-81); Novelle (1682-86), Belgian; Gonzalez (1687-1705), Spaniard; Tamburini (1706-30); Retz (1730-50), Bohemian; Visconti (1751-55); Centurioni (1755-57); Ricci (1758-75); Brzozowski (1805-20), Pole; Fortis (1820-29); Roothaan (1829-53), Dutch; Beckx (1853-84), Belgian; Anderledy (1884), Swiss; Martin (1892), Spaniard.

The literature of the history of the Jesuits, whether hostile or friendly, is almost endless in extent and variety; reference may be made to Gioberti, *Il Gesuita Moderno* (1847), and Creteineau Joly, *Histoire de la Compagnie de Jesus* (1845); to the histories by Wolff (2d ed. 1803), Stemmetz, Huber, Guettee (1859), Theleman (1873), Griesinger (Eng. trans. 2d ed. 1885); Parkman's *Jesuits of North America in the 17th century* (20th ed. 1886); Ranke's *Römische Päpste* (6th ed. 1871); Foley's *Records of the English Province of the Society of Jesus*; T. G. Law, *Conflicts between Jesuits and Seculars under Elizabeth* (1890). See also CASUSTRY, LOYOLA, XAVIER.

Jesuits' Bark. See CINCHONA.

Jesus, son of Sirach. See ECCLESIASTICUS.

Jesus Christ. It is obvious that any attempt to speak in a few pages of a life which was divine as well as human—of a life which stands at the very centre of the world's history as the fulfilment of all the past hopes of humanity, and as the highest ideal of all its future aims—can only be carried out by rigid limitation of the end in view. It will be impossible here to enter into any critical inquiries; or into profound theological discussions respecting the inter-relation of the two natures in one person; or into a review of philosophical theories respecting the work and person of Jesus; or into a defence of the *a priori* possibility or credibility of miracles; or into a minute examination of conflicting systems of chronology; or into a harmony of the variations in the historical narratives which have been magnified into irreconcilable discrepancies. On such questions we can barely touch, referring for further information to the articles on CHRISTIANITY, CHRISTOLOGY, CHRONOLOGY, GOSPELS, JOHN, and MIRACLES.

The sources of our knowledge of the life of Jesus are almost exclusively biblical. The references to Him in Jewish and heathen literature are distorted by hatred, prejudice, and ignorance; and the only additions to our knowledge which can be gleaned from the Christian literature of the early centuries are dubious in authenticity, and insignificant in amount. Though legend has connected the name of Philo with the apostle Peter, the learned Alexandrian lived too early to be reached by the growing force of Christianity, and makes no allusion to it. Some critics have imagined the existence of Christian interpolations in Philo's account of the Therapeutic. Josephus speaks briefly of John the Baptist, and of the martyrdom of James, the Lord's brother; but the authenticity of the famous passage about Christ is now given up in its present form, for it must in any case have been tampered with by some Christian scribe. The silence of Josephus can only have been due to perplexity or policy. From other Jewish references we learn nothing except the blinding fury of the malignity excited by the name of Christ. The blasphemous scandals and immoderies of the Talmud, which culminate in such deplorable medieval calumnies as the *Toldoth Jeschu*, are lamented by all respectable Jews, and indeed they refute themselves by their preposterous anachronisms and impossible absurdities. Generally the Talmudists veil their hatred under distant allusions to 'so and so,' 'Absalom,' 'the fool,' 'the hung;' and they conceal a malediction under the form in which they write the name of Jesus. Suetonius only alludes to Christ (if at all) under the blundering notion that he ('Christus') stirred up troubles in Rome in the days of Claudius. Tacitus historically records the crucifixion, but is otherwise as grossly ignorant of every fact about the Christians as he is about the Jews. The only notion of Christianity entertained by him, by Suetonius, and by Pliny is derived either from the monstrous falsehoods of pagan enemies or from a confusion of Christians

with the members of the vilest Jewish and Gnostic sects. Not one fact can be disinterred from the cynical perillage of Lucian in his tract on the death of Peregrinus, or from the anonymous Philopseudes. Celsus, indeed, professes to have studied the documents of Christianity, but his views had been tainted, partly by the hostile prejudices of philosophy, and partly by his reliance on the invention of scandal-mongering Jews. It is more disappointing that no fact about Jesus can be derived from the earliest Christian literature. There is scarcely a single grain of gold in the accumulated rubbish-heap of legends contained in the apocryphal gospels; not a single fact in the allusions of the Fathers on which we can rely, unless it be the statement that the stable of the Nativity was a cavern; not a single unrecorded saying of Christ (*ἰσχυροὺς λόγους*), unless it be 'Prove yourselves good money-changers;' or one or two others which—like 'He who is near me is near the fire'—are already implicitly contained in the records of the gospels.

We therefore turn to the New Testament, and here no *facts* of the life are preserved for us except those which are recorded in the gospels, and receive independent attestation from the references of St John, St Peter, and St Paul. St Paul preserves for us the one unrecorded precious maxim, 'It is more blessed to give than to receive,' but nothing more. The question therefore arises, 'May we rely on the four gospels as authentic and adequate?' That they are so might seem to be sufficiently proved by the existence and the ever-growing strength of Christianity and Christendom—the religion and the society which are based upon them. They have indeed been placed in the crucible and thrust into the hottest furnace of modern criticism, but only with this result that in these days scarcely a critic pretends to impugn the general historic truthfulness of the synoptic narratives, though many endeavour to eliminate the supernatural elements. The characteristics of the gospels themselves—their simplicity, their naive confessions, their inimitable stamp of honesty and veracity (the *simpliciter veri sigillum*), the impossibility that the Character which they set forth should have been invented by fishermen and tax-gatherers, the historic verification of which they are capable—are the pledge of their authenticity. And of the various theories which have been adopted to explain away their significance one after another has hopelessly broken down. Paulus attempted to account for the gospels on naturalistic grounds, so that miracles were merely mistakes of enthusiastic observation; but after the crushing exposure of this hypothesis by Strauss it has never been revived. Strauss, with imposing wealth of learning and ability, tried to apply to them the principles of Hegel, and to explain them as myths generated by the idea; but after a temporary success he was himself forced to complain that his views had been swept away by the orthodox reaction. Even Renan says of Strauss's *Leben Jesu*, 'Ce Christ *a priori*, ou le divine bien, n'est pas encore le Christ historique'—*Et. d'Hist. Rel.* pp. 157-58; and in point of fact Strauss was rebutted by the intense and unique originality of the gospel story, and by the fact that no miracle was attributed to John the Baptist even at the zenith of his mighty influence. Baur and his able successors helped to nullify the arguments of Strauss, and in their turn applied to the story of the origins of Christianity the strong solvent of criticism; but his followers had to make larger admissions than he himself, and his attempt to show that the gospels were 'tendency-writings' proved itself so little satisfactory, and was so completely counteracted by the writings of Neander and others, that at Tübingen itself there is a

Tübingen school no more (Ewald, *Gesch. Christus, Vorrede*, p. xxvii. 3d ed.). Lastly there arose the eclectic schools of Schleiermacher and Renan. The medial system (*Vermittelungs-Theologie*) of Schleiermacher produced a powerful effect, but the day for half-views has gone by. The success of Renan was due mainly to the charm of style, but he was not sufficiently serious to captivate many proselytes. His *Vie de Jésus* was vitiated in part by the writer's own vacillations about the fourth gospel and in part by the indignant scorn which was kindled by his hypothesis that He whom the world has recognised as *verax et verus et ipsa veritas* lent Himself to wilful deception in the raising of Lazarus. The unshaken belief of the vast majority of Christians, even of those who have most thoroughly examined the literature of scepticism, is sufficient to prove that modern apologetics have been adequate to sustain the far fiercer battle of the forces which were routed in the earlier centuries by Origen and Athanasius, and in the 18th by Butler, Lardner, and Paley.

The attack on the authenticity of the fourth gospel has been longer and more determined, but the evidence has been exhausted with careful accuracy and stated with perfect candour, and we may point to the papers of Bishop Lightfoot and the edition of the Gospel of St John by Bishop Westcott as containing arguments which seem finally decisive against the destructive critics. On this subject the author of *Supernatural Religion* was practically driven out of the field, and the certainty that Tatian in his Diatessaron used the fourth as well as the other gospels—which has now been proved by the discovery of an Armenian translation of Ephraem's commentary in the library of the Mechitarist Fathers at Venice in 1836—is a strong addition to the weight of external evidence. This commentary of Ephraem was translated into Latin by Ancher in 1841, and published by De Mösinger in 1876. Tatian was a hearer of Justin Martyr, and his undoubted acceptance of the fourth gospel gives certainty to the already strong probability that that gospel was accepted by Justin.

Before proceeding to set forth in its general idea the narrative of the gospels some preliminary considerations must be passed in review. It is essential to notice that the life of Christ, as related in the gospels, is partial and fragmentary. It has been calculated that in narrating the public ministry of Christ the synoptic gospels only deal with the events of fifteen months (450 days); but that so little consecutive is the narrative that not more than thirty-five days are distinctly touched upon, while there are *lacunæ*, in which the events of one, two, or even three months at a time are passed over in silence. Further, it has been observed that the records of two or three of these days—the day in the cornfield (Matt. xii. 1-xiii. 52), the day of the Sermon on the Mount (Matt. v. 1-viii. 17)—occupy large fractions of St Matthew's Gospel; the day of the cursing of the fig-tree occupies one-seventh of St Mark's; and the story of five days (Luke, xx. 1-xxiv.) occupies one-fourth of St Luke's, exclusive of the story of the infancy. If this computation be accepted, the result is that the Synoptists move in the sphere of one-thirteenth part of a ministry of which the extent is uncertain, but which is generally believed to have covered little more than three years (see Dr Martineau's *Seat of Authority in Religion*, p. 185). It is a legitimate inference from this that much of our Lord's public activity is unrecorded; but this is what St John himself distinctly tells us (John, xxi. 25). The gospels were written to establish a faith, not to detail a biography; to record the essence of a teaching, and to testify to

the majesty of a Personality, not to depict the minute incidents which had but a slight or secondary bearing on the great design. There are vast spaces in the heavens which are not sown with stars, and the 'ceconomy,' both divine and human, which marks the scantiness of the evangelic narrative of the ministry is but a part of that simplicity and reticence which contented itself with so brief and (from the ordinary point of view) so meagre a reference to the thirty long years of the Saviour's growth and preparation.

On the very threshold of any attempt to speak of Christ we are met by the fact that, in the belief of one-third of the human race, He was not a simple man but a Divine man, the God-Man; the Son of Man as the unique representative of humanity at its best and greatest, but also pre-eminently—and in a sense transcendently different from that in which the phrase can be applied to men—the Son of God. To those who take the fact in a bare isolated way it may seem an insuperable stumbling-block; not so to those who do not disconnect it from the whole conception of God and the entire history of the world. Nothing is more unphilosophical than the *a priori* rejection of miracles, because miracles do not come under the range of ordinary experience. 'Historic problems cannot be thus settled by philosophic categories.' If we start with that belief in God which may be regarded as the normal datum of our human consciousness, and if we contemplate the historic fact of the fall and wretchedness of man, the belief that God—in compassion for and in order to redeem and elevate the countless millions of mankind in all their generations—became man, and took our nature upon Him in the person of His Son, so far from seeming a monstrous hypothesis, appears to be in exact accordance with His nature, as the best and highest that we know and can imagine. Those who, like Spinoza, identify God with Nature, which is but the sum total of His visible manifestations, exclude from Nature the sole element which explains it—viz. the element of a Divine and Supreme Will.

Nature alone can furnish us with no explanation of the manifestation of Christ, but it harmonises absolutely with that idea of God which we believe that He has Himself planted within us. So completely is this the case that—as was seen by the great German historian, Julius von Müller—apart from Christ all human history is reduced to a chaotic dream (see his letter to his friend, Karl Bonnet, quoted by Luthardt, *Apology, Vortr.*; Eng. trans. p. 353). All the history of the past, up to the Incarnation, points to Him, and in Him finds its fulfilment; all the development of the ages since He appeared springs from the divine impulse which He gave. As Jean Paul Richter so finely said: 'He lifted the gate of the centuries from off its hinges with His bleeding hand.' The most sceptical of historians cannot fail to see that Jesus stands at the very centre of humanity. Not only was all which is most precious in Hebrew literature full of unspeakable yearnings for this Divine Deliverer, but even heathendom abounds in unconscious prophecies of His advent. Among the Persians we read in the *Zend-Avesta* of 'the victorious Saoshyant, the beneficent one who will benefit the whole bodily world, who will stand against the destruction of the bodily creatures to withstand the *Drug* of the two footed brood.' He is the redeemer, born of Zoroaster, who shall crush the serpent-destroyer Ahriman (see *Zend-Avesta*, Yast XXVIII, *Sacred Books of the East*, p. 220). So, too, in Brahmanism we have the redeemer Krishna, who is constantly represented as crushing and conquering the serpent. Among the Greeks we have the profound legend of Prometheus, the

representative of suffering humanity, who can only be delivered from his fetters on the rock, and the tearing of the vulture's talons, when Herakles the son of Zeus descends for him into Tartarus. (Consider the remarkable lines, *Æsch. Prom.* 1026-30, one of the most striking of the unconscious prophecies of heathendom.) Socrates puts into the mouth of Plato his confession of the necessity for some divine deliverer who is at once both God and man (see Ackermann, *Das Christliche in Plato*, Hamburg, 1835); and some such figure has been dreamed of in all the higher forms of religion as a necessary inference from what we know both of God and man. The revelation of Christ springs as a necessary postulate from our faith in God. For some remarkable passages in the ancients, see Cic. *De Legg.*, ii. 10; Sen. *Ep.* 52; and Schneider, *Christliche Klotung*.

But in speaking of the human life of Jesus it is unnecessary to entangle ourselves in the intense and prolonged theological battles which culminated in the 3d and 4th centuries. The result of those controversies is adequately summed up in the four technical terms *ἀληθῶς, τέλειος, ἀδιακρίτως, ἀσινγύτως*, decided on in the four councils of Nice, Constantinople, Ephesus, and Chalcedon. As against the Arians, Christ was *truly* God; as against the Apollinarians, He was *perfectly* man; as against the Nestorians, He was *indivisibly* God-man; as against the Eutychians, He was *distinctly* God and man. Beyond these elementary decisions all attempts to deal with that *arcanum* of theology, the *περιχώρησις* or *communicatio idiomatum*, can only end in failure and absurdity (see Hooker, *Ecol. Pol.*, Book V., liv. § 10). But if it be assumed that it is impossible or irreverent to narrate the earthly life of such a Being, the answer is that it has been done in the four gospels, and that to shrink from doing it would be only due to the false reverence of Apollinarianism—now quite as common in the church as Arianism is in the world—which denied the full humanity of Christ. It is most necessary, too, to bear in mind that throughout Christ's earthly life, from the Incarnation to the Resurrection, He voluntarily laid aside, in obedience to the perfect conditions of humanity, the divine attributes of omniscience and omnipresence. 'Being in the form of God, He thought it not a prize to be on an equality with God, but *emptied Himself* (*ἐκένωσε ἑαυτὸν*), taking the form of a servant, being made in the likeness of man' (Phil. ii. 5, 6, Revised Version). The doctrine here revealed is known in theology as the *Kenosis* or 'emptying,' and in speaking of Jesus we have constantly to bear it in mind, as the necessary condition of His being 'a man with man,' of His coming *ad Judæos et Judæos apud Judæos*, of His 'wearing a tent like ours, and of the same material.'

We proceed then to sketch in barest outline 'those sinless years which breathed beneath the Syrian blue,' Jesus, as appears by both the genealogies recorded in the gospels, was of the royal house of David. The discrepancies and divergences of those genealogies are believed to be due to the differences between His legal and His natural descent, which in one or two places of the line was affected by a collateral adoption, or a levirate marriage. His virgin birth is attested and assumed by the evangelists, and St Luke, using Hebrew documents which seem to be directly traceable to the memories of the Virgin Mary, preserves for us particulars about the infancy of Jesus which are not found in the other Evangelists. Even the apocryphal gospels revel in impossible and even revolting details, and, stumbling on the very threshold, present us with a picture which would have been instantly destructive of our faith if it had been true. The canonical gospels vindicate

their truthfulness and their supremacy by the severest reticence, which contains no word to mar that ideal which every effort of invention instantly degrades. After the marvels of the Nativity at Bethlehem, we are told of the circumcision, the presentation in the temple, the visit of the Magi, the flight into Egypt, and the massacre of the innocents. The exact date of these events cannot be determined with absolute certainty, but may be brought within narrow limits, and most scholars now acquiesce in the view which places the Nativity about four years earlier than our received era. The historic questions which the narrative raises have been sited to the bottom, and the credibility of the gospel details has been triumphantly established.

After the infancy there is a deep silence which covers all but the concluding fragment of the life of Christ. From the return to Nazareth, while He was yet a very young child, to the baptism by John we have nothing preserved to us except a single anecdote by St Luke, and a single word in St Mark. It is exactly respecting this portion of the life of Christ that the apocryphal gospels most deeply betray incompetent falsity, and the gospels show that grace of superintendency without which they could not have recorded what the apostles had seen and heard when their hands handled the Word of Life. The anecdote of St Luke is Christ's visit to the temple with his parents at the Passover just before His thirteenth year, which marked the age of a Jewish boy's 'confirmation'—his admission to the rank of a 'son of the law' (*ben hat-torah*). It has been called 'the solitary floweret out of the wonderful enclosed garden of the thirty years, plucked precisely there when the swollen bud at a distinctive crisis bursts into flower' (Stier, *Leben Jesu*, i. 18). It is specially precious from the decisive way in which it shows that Christ possessed a human soul, and not only the *Logos* instead of it; and it exactly accords with the testimony of St Luke that our Lord's growth was that of a child in whom there was a *gradual* increase of knowledge (Luke, ii. 40, *πληρούμενον* not *πεπληρωμένον*). Indeed it seems to have been the special purpose of the third evangelist to give us at least one glimpse of Jesus at every phase of His human life, as an infant, a child, a boy, a youth, and a full-grown man.

The one word happily preserved for us by St Mark is 'the carpenter' in the question of the unbelieving Nazarenes, 'Is not this *the carpenter?*' which an irreverent reverence has altered into '*the son of the carpenter.*' It shows us that, as a part of that infinite self-repression and obedience by which Christ 'abode with His parents and was subject unto them,' He shared with Joseph in the humble trade by which he earned his daily bread. Unanimous tradition, implied by the gospels themselves, agrees in the belief that Joseph died early, and that our Lord grew up in a family circle of those whom the evangelists call His 'brothers' and 'sisters.' In that family He was the first-born, and probably helped to support them all. To any imagination which was not divinely guided such a mode of spending all but three years of His life would have seemed impossible and derogatory; but the admission is one of the most striking proofs of the absolute veracity of the gospels. Their silence as to all other records of those thirty years preaches to us with the most majestic eloquence. Some of the greatest lessons of Christ's example are involved in the fact that He did not strive, nor cry, neither was His voice heard in the streets. The central lesson that 'Christ pleased not Himself' is written large over the closed golden portals of those unrecorded years. Coming to live

for man, He chose the lot not of the few but of the countless multitudes, the immense majority. The town and the home which He chose were alike poor, provincial, insignificant. Thus He rebuked pride, which is one of the two great taproots of human aberration; He showed the sacredness of obscurity; He glorified the lot of labour which antiquity despised. Rebuking the restless passion for excitement and the desire to minister to self-importance, He showed to all mankind that the true life is the *interior* life, the life of calm, recollectedness, and companionship with the divine, passed in the sweet seclusion of a home and the ordered routine of lowly duties. It is impossible for most men to live as Christ lived during His brief ministry; but that unknown life of the artisan in dull, provincial Nazareth was meant to teach us that the commonplace ordinary life, which is the normal life of man, may yet be precious with the best sanctities of heaven's beatitude.

Thus ended the first and main part of the life of Jesus. At the age of thirty began the second phase of His life, the public ministry—ending with the Crucifixion and the Resurrection—which occupies all but a fraction of the gospels. St Peter's epitome of that ministry is that 'He went about doing good,' and it was by giving up everything which the earthly and sensual mind can desire that He left us an example that we should follow His steps. To detail the events of that ministry is obviously impossible here, nor is it necessary. We shall but indicate its great phases and divisions, and then touch on some of the considerations which it suggests. It falls into the following great divisions:

I. The call to the ministry in the baptism and preaching of John the Baptist, who first publicly recognised Jesus as the Messiah.

II. The temptation in the wilderness.

III. The call of the first apostles; the first miracle at Cana; the beginning of the preaching in Galilee.

IV. The first Passover visit to Jerusalem, the first cleansing of the temple. The question of the rulers, and the prophecy 'Destroy this Temple,' &c. The interview with Nicodemus; the retirement to Galilee; the discourse to the Samaritan woman at the well; the rejection by the Nazarenes.

V. The 'Galilean springtide' of the ministry amid the gladness of the multitudes; many miracles of healing; the choice of the twelve; the Sermon on the Mount; the message from the imprisoned Baptist; the intercourse with Pharisees, publicans, and sinners; the great day of parables; the visit to Gergesa; the day of Matthew's feast.

VI. The second visit to Jerusalem; the miracle at Bethesda; the murder of the Baptist; the return to Galilee.

VII. The feeding of the five thousand; the discourse at Capernaum; the Sabbath and other disputes, amid ever-deepening conflict and opposition.

VIII. The flight among the heathen; the Syro-Phoenician woman; the return to Decapolis; the epoch of rarer miracles; the feeding of the four thousand; the recognition of the Messiahship by the disciples; the Transfiguration; the healing of the demoniac boy.

IX. The visit to Jerusalem at the Feast of Tabernacles; the woman taken in adultery; the healing of the man born blind; the return to Galilee.

X. The final farewell to Galilee. Incidents and teachings of a slow journey towards Jerusalem. Visit to Jerusalem at the Feast of Dedication. The last stay in Perea; the raising of Lazarus. Jesus, under a ban, withdraws to the town of Ephraim.

XI. The last visit to Jerusalem. The events of Passion Week—Palm Sunday; the day of parables; the day of temptations; the great denunciations; the farewell to the temple; the betrayal.

XII. The Last Supper; the last discourse; the agony in Gethsemane; the arrest; the threefold trials; the Crucifixion; the Resurrection; the great forty days; the Ascension.

Such being the great divisions and landmarks of the life, it only remains to touch on one or two of the important questions which it suggests.

i. What was the length of our Lord's public ministry? We are unable to answer the question with certainty. This is due to the remarkable fact that the synoptic gospels occupy themselves almost exclusively with the Galilean ministry, while St John mainly dwells on the ministry in Judea and Jerusalem. Sceptics have vainly endeavoured to extort any discrepancy from this fact, since the Synoptists most distinctly imply that much of our Lord's time must have been spent in Jerusalem (see Luke, x. 38, xix. 42; Mark, xi. 11)—a fact, indeed, directly stated in the recorded *πρόσῳδος* ('how often') in His lament over Jerusalem (Matt. xxiii. 37; Luke, xiii. 34). We may then decidedly reject the notion of a *one-year's* ministry, which has been most unwarrantably founded on the expression of Isaiah (lxi. 2) and the reference to it by our Lord at Nazareth (Luke, iv. 19). This was the view of Origen (*De Princ.* iv. 5), and Clement of Alexandria (*Strom.* i. xxi. sect. 145), and of the two Gnostic teachers, Ptolemæus (*Ep. ad Florum*) and Herakleon; but not that of Melito and Irenæus. It has found powerful supporters in Browne (*Ordo Sacrorum*, pp. 342-91), and Keim (*Jesu von Nazara*); but the former can only maintain it by eliminating τὸ πάσχα from John, vi. 4, *in spite of all the manuscripts*, and the latter by rejecting the authenticity and credibility of the fourth gospel. The majority of scholars agree in the well-founded inference stated as early as Hippolytus, the scholar of Irenæus, Eusebius (H.E. i. 10), Theodoret (in Dan. ix. 27), and Jerome, that Jesus died at the age of thirty-three, and that the ministry lasted more than two and a half years. Irenæus's extraordinary assertion (*C. Her.* ii. 2515) that Jesus died between the ages of forty and fifty is a blunder (which in him is not isolated), falsely inferred from John, viii. 57. The only element of uncertainty for those who accept the fourth gospel is the identification of the unnamed feast mentioned by St John in v. 1. If that feast was the Jewish feast of Purim we see that St John groups his narrative round *five* festivals—(1) the Passover (ii. 13); (2) Purim (v. 1); (3) the Passover (vi. 4); (4) the Tabernacles (vii. 2); (5) the Dedication (x. 22); (6) the Passover (xi. 65). It is in accordance with this that Purim took place on Veadar 14 (about March 19), and that our Lord (some time before the feast) said to the woman of Samaria 'there are yet four months unto harvest' (John, iv. 35). Since, then, there were three Passovers during the ministry, and that ministry began some time before the first Passover, we see a reason for the view that it lasted about three years—a view which best accords with all the data. And though we cannot here discuss the chronology, the opinion that Christ's baptism by John took place in the summer of 26 A.D., and that He was crucified in the spring of 29 A.D., is probably not far wrong.

ii. Without entering into the subject of apologetics, we may allude to the miracles which enter so largely into the life of Jesus, and which, as they were a support to the faith of former centuries, are regarded as a stumbling-block by modern science. St John puts us into the right point of view when he calls them *works* (*ἔργα*—John, v. 20, and *passim*). Given the Personality of Christ, miracles were natural to Him; 'our supernatural was His natural.' Their occurrence becomes a question of evidence, and the supposed recalcitrant and dangerous formula of Hume 'reduces itself to the very

harmless proposition that anything is incredible which is contrary to a *complete* induction.' When Hume said that no evidence could establish a miracle, because it was more likely that evidence should be false than that a miracle should be true, his statement came to no more than this—that a miracle disturbs the mechanical expectation of a recurrence (Mozley, *Bampton Lectures*, p. 56). Hume did not argue for so unphilosophical an assertion as the *impossibility* of miracles, but he argued against their *credibility*, because his philosophy practically reduced life to a series of impressions and sensations. In answer, it is enough to say with Lord Bacon, 'the soul of man was not produced by heaven or earth, but was breathed immediately from God; so the ways and dealings of God with spirits are not included in Nature—i.e. in the laws of heaven and earth, but are reserved to the law of His secret work and grace.' The evidence for Christ's miracles, and above all for His Resurrection, has been sufficient to convince and potent to ameliorate the whole civilised world.

iii. Christians rightly regard the Resurrection as the one fundamental historic miracle on which rests their *historic* faith. If any fact can be regarded as indisputable it is the fact that on the morning of the first Easter Sunday the astonished disciples found that there was no corpse in the rock-hewn sepulchre. So much is now freely conceded by the most advanced sceptics. The testimony in favour of the fact is overwhelming, and it is impossible to account for the existence of Christianity or of Christendom on any hypothesis other than the firm conviction in a miraculous Resurrection, of which all the early disciples regarded themselves as the chosen witnesses. The modern criticism of unbelief has only attempted to account for the empty tomb by theories which sink to the ground under the weight of their own impossibility. The notion of a merely *apparent* death from which Jesus was revived by the spices and the cool sepulchre; the notion that the apostles stole the body by night; the notion that Jesus was not crucified at all, but only someone in His place; the notion that 'the faith of Christendom is founded on the self-deception of an *hallucination*'—have been in turn adopted and abandoned. Such naturalistic explanations are impossible, unless they be bolstered up by the preposterous supposition that, at some stage, deliberate deception was at work, and that the teachers of the religion which is pre-eminent in inculcating the sanctity of truth founded their preaching upon a lie. It is not possible here to develop the arguments, or to array the evidence, on which our faith in a literal Resurrection of Jesus in a glorified and spiritual body is founded. We must be content to refer to such works as those of Gebhardt (Gotha, 1864), Beyschlag (Berlin, 1865), Steinmeyer (Berlin, 1871), and Bishop Westcott on *The Gospel of the Resurrection* (Lond. 1884).

iv. And it must be borne in mind that, if scepticism could eliminate from the gospels what is called the supernatural element, it would still be confronted with the superhuman grandeur of Christ Himself. So far from tending to discredit the narratives of the miracles which He wrought, it may rather be said that Science tends to throw light upon their accordance with the yet undeciphered laws of nature; but even were every miracle eliminated, Christ still continues to be what even those who have doubted of His divinity call Him, '*ein Mysterium, ein Unicum*.' The proof of His divinity is involved in His perfect sinlessness, which not only transcends the attainments but even the ideal of humanity. Infinite in its many-sidedness, His character is yet supreme from every aspect in which it can be regarded. Not only is He the

sole human being whom sinlessness has claimed, or of whom sinlessness can for a moment be predicated, but the ideal presented by His character stands apart, not only from that in the life of the best pagans, but even of those whose life was a professed imitation of His. And more even than this, imagination has again and again attempted at least to conceive and depict a character absolutely stainless, and yet, in the whole range of the world's poetry and fiction, has never attempted to do so without hopeless failure if it descended for a moment into details. Could the peasants of Galilee have invented the sole perfect ideal which the world has been able either to imagine or describe? To this is attributable the remarkable fact that even the most pronounced sceptics—even those opponents of Christianity who would gladly have got rid altogether of the admiration of Christ—seem to have been unable to contemplate Him without as if were falling on their knees. 'Between Him and whoever else in this world,' said Napoleon to General Bertrand, 'there is no possible form of comparison.' 'Jesus is in all unique,' says Renan, 'and nothing could be compared to him' (*Vie de Jesus*, p. 457). Strauss calls Him 'the Being without whose presence in the mind perfect piety is impossible.' Goethe called Him 'the Divine Man, the Saint, the type and model of all men' (*Conversations with Eckermann*, ii. 3). J. S. Mill said that 'it would not be easy even now, even for an unbeliever, to find a better translation of the rule of virtue from the abstract into the concrete than to endeavour so to live that Christ would approve our life.' The character of Jesus was sufficient to overawe even the lippancy of Voltaire, as we see in the story of his remarkable dream.

v. Nothing short of a divine personality can account for the stupendous and inexhaustible effect produced upon the world by the life and teaching of Christ—a life so short that He died before the full completion of the powers of manhood; a ministry so confined in space, so contracted in time. That life, lived on a stage so narrow, furnished to mankind the sole perfect pattern and example; that teaching involved every element of pure and perfect spiritual religion. It was Christ alone who first brought home to the mind of man that God is love, and that man is the son of God; and first brought life and immortality to light. And as Christ thus became the Saviour of mankind by example and teaching, so also did He redeem the race by the self-sacrifice which culminated in the cross and passion, and which is continued by His Resurrection, Ascension, and session at the right hand of God. By this His life He has redeemed us from sin and death, and reconciled us unto God. That mighty work of individual regeneration which Christ began has been carried on by the gift of the Spirit, which, in the slow process of centuries, has made holiness a common attainment of His saints, and leavened, humanised, ennobled the thoughts, the lives, the families, the society, the kingdoms of mankind. And the Christian believes that that work will continue until 'the kingdoms of this world' become universally, and in reality as well as in name, the kingdom of our Lord and of His Christ.

The literature of this subject is inexhaustible, and every year adds to its enormous accumulations. It begins with the gospels and epistles in the 1st century of the Christian era, and continues in unbroken succession through the Fathers, the Schoolmen, and the Reformers, down to modern days. The first attempt to write a consecutive life of Christ, outside the authentic and apocryphal gospels, was the *Vita Christi*, by St. Bonaventura. The *Paradise Regained* of Milton was practically an effort in the same direction. The lives of Christ of later times are very numerous: in Italian, that by Capecciatro (Naples, 1868); in French, those of De

Pressensé, Dupanloup, Salvador, Wallon, and Renan; in German, those of Caspari, Ewald, Hase, Hofmann, Lange, Neander, Sepp, Strauss, Weiss, Keim, and many more; in English, those of Ellicott, Geikie, Edersheim, and, among others far too numerous to mention, that by the present writer in 1874, which has called out such a multitude of successors. See also the articles on JOSEPH and on MARY.

Jet, a dense variety of lignite passing by degrees of quality into bituminous fossil wood, sometimes perfectly black, capable of being easily cut and carved, and of receiving a very beautiful polish. It takes its name from Gagag or Gages, a place in Asia Minor, where, according to Pliny, the substance was obtained, whence in his time it was called gagates, afterwards corrupted into gagat, the modern German name, and jet. Jet is only a peculiar form of lignite, impregnated with bituminous matter, and containing about 37½ per cent. of volatile matter. It is electrical when rubbed; hence it has been called 'black amber' by the Prussian amber-diggers.

Of substances used for trinkets and personal ornament, apart from metals, jet appears to be one of the most ancient. At numerous places throughout Great Britain necklaces, beads, buttons, and other small objects of jet have been discovered, showing that it had been used in the early bronze period. Probably at that remote time it was obtained from the Yorkshire coast about Whitby, whence the principal supply and the finest quality anywhere obtained continues to come. The jet occurs at Whitby in irregular interbedded patches in the Upper Lias shales, two kinds, hard and soft, being found; but only the hard is of value for ornaments. The industry there gives employment to a large proportion of the population. It is also worked in France in the department of Aude, where it is formed into rosary beads, crosses, and other trinkets. Spain also supplies fine jet, which, like that of the French workings, is found in irregular veins in the lower marls of the Cretaceous series, corresponding with the Sussex gault. The Spanish jet is found at Villavieja, in the province of the Asturias, and is principally manufactured at Oviedo. As a material for mourning ornaments jet is admirably adapted, and for that purpose is largely used. Imitations of jet ornaments are made in the hardened india rubber called Vulcanite or Ebonite, and in glass.

Jeton, a round, flat piece of metal, ivory, &c., formerly used for counting, or as counters at play, and also as a check given to members of a society passing in to its meetings.

Jetsam, JETTISON. See FLOTSAM.

Jennessé Dorée ('gilded youth'), a party name given to those young men of Paris who, during the French Revolution, struggled to bring about the reaction or counter-revolution after Robespierre's fall (27th July 1794). Other nicknames bestowed upon the same party were *Muscadins* ('scented darlings') and *Petits-Maitres* ('elegants'). The term *jeunesse dorée* is still in use to designate young men about town, who always go elegantly dressed, have the air of spending money, and live a butterfly life of enjoyment and pleasure.

Jevons, WILLIAM STANLEY, born in Liverpool in 1835, was educated there and at University College, London, and from 1854 to 1859 held a position in the mint at Sydney. In the London M.A. examinations in 1862 he took the gold medal in philosophy; in 1866 he was appointed professor of Logic and Mental Philosophy, and of Political Economy, at Owens College, Manchester; and in 1876-81 he was professor of Political Economy at University College, London. He was elected

F.R.S. in 1872, and received the degree of LL.D. from Edinburgh in 1876. On 13th August 1882 he was drowned whilst bathing at Bexhill, near Hastings. Jevons was the first to popularise the mathematical methods of Boole (q.v.), and so to bring symbolic logic within the capacity of beginners. Among his works in this field are his *Elementary Lessons in Logic* (1870), a very popular text book; *The Principles of Science* (1874), perhaps his most important work; a collection of useful *Studies in Deductive Logic* (1880); and *Pure Logic, and other Minor Works* (1890). To the science of political economy he contributed, besides a primer and several pamphlets, and a work on *The Coal Question* (1865), which led to the appointment of a Royal Commission, his valuable *Theory of Political Economy* (1871; 3d ed. 1888), in which the conception of 'final utility' was first distinctly formulated. See his *Letters and Journals*, edited by his wife (1886).

Jew. WANDERING. See WANDERING JEW.

Jewel. JOHN, one of the fathers of English Protestantism, was born at Berryarbor, near Hfracombe, in 1522, and was educated at Barnstable school, and afterwards at Merton and Corpus Christi Colleges, Oxford. He was admitted B.A. in 1540, and must early have imbibed Reformed doctrines, as he was closely intimate with Peter Martyr during his visit to Oxford. Soon after the accession of Mary he went abroad for safety's sake, visiting Frankfort and Strasburg, and returned on the accession of Elizabeth, by whom he was almost immediately appointed Bishop of Salisbury. His great controversial ability soon made him one of the foremost churchmen of his age, and indeed his famous *Apologia Ecclesie Anglicane* (1562) retains its value as a triumphant exposure of the pretensions of Rome. Bishop Jewel's unwearied devotedness at once to his episcopal duties and to the demands of a great controversy wore out his strength, and brought him to the rest of the grave in his fiftieth year, 22d September 1571.

A collected edition of his works was published in folio in 1609. More recent editions are those by the Rev. John Ayre in the Parker Society (4 vols. 1845-50), and by the Rev. Dr R. W. Jelf (Oxford, 8 vols. 1847-48). An early life is reprinted in Wordsworth's *Ecclesiastical Biography*. See also the Life by C. W. Le Bas (1835).

Jewellery. The word 'jewel' is from the Old French *joel*, a diminutive of *joie*; Ital. *gioja*, 'joy'; Lat. *ignavia*. Jewellery embraces primarily articles intended for personal decoration, made of precious metals, which may be enriched with stones or enamels. But objects, also, not intended for personal use, such as caskets, when decorated with precious stones are said to be jewelled, and the term jewel has a further restricted signification when it is applied to one of the insignia of the knightly orders. Popularly, there is much confusion between the terms gem and jewel; the former belongs especially to engraved stones (see GEM). The love of personal ornamentation is a primal passion of humanity, which sways with equal force the rudest of tribes and the most advanced and luxurious communities. The craving which impels the rude savage to decorate his or her person with beads and circlets of seeds, shell, bone, horn, and wood is the same which has caused monarchs to lavish their treasures on the costliest materials and the most exquisite workmanship of their crowns and insignia of state. Jewellery thus in its wide acceptance as a purely ornamental adjunct to the person has been in use at all times and by the entire human family. And as on these adornments the highest art and skill at the command of any people was always lavished, they afford some measure of the condition of the handi-

crafts and of the artistic development of the people and the period to which they belong. Further, in the days when banking and money-lending were not a factor in commerce, the accumulation of jewellery formed one of the most convenient of methods for the storing of realised wealth. It is so in India at the present day.

Before the use of metals was known, jewellery, if it can be so termed, consisted of carved beads and fragments of such bright substances as were at the command of prehistoric man. Gold is the first metal of which there is any mention in literature, and there is no doubt that, being always found native, it was the first to be used by mankind. The earliest gold ornaments would be the native pellets of the metal as found, and when mankind possessed no mechanical resources beyond rude hammers of stone, with which to beat out these pellets, the possibilities of decorative treatment of gold were very limited. The ability to melt metals and so to obtain masses of large size upon which to work implies a very advanced knowledge, to which, however, artificers must have attained at a very early period. Among the numerous finds of gold jewellery of prehistoric times there are many specimens which show that the early artificers possessed considerable command over their material in the way of hammering out plates to uniform thickness, drawing or beating the metal into wire, and plaiting and twisting it into torques, armilles, rings, and other forms of ornament. In these earliest gold ornaments there is no attempt at decorative treatment other than what could be produced by the hammer; and it is only by degrees that simple efforts at chasing, engraving, and embossing make their appearance. The most archaic gold ornaments discovered by Dr Schliemann in his excavations at Hissarlik, which he regards as ancient Troy, are treated with the hammer alone; the later gold ornaments of Mycenae are of a much more developed character, showing a knowledge of chasing and embossing. It is only when we come to historical times that we find artificers had obtained command over their material and tools sufficient to enable them to produce jewellery which bears a distinct impress of the art and ornament of their period and nation.

To trace the development of jewellery throughout ancient and mediæval times would simply be to follow the course of art and the arts among the leading civilised communities. Fortunately the tombs of the dead, and hoards which have apparently been hid to escape the ravages of enemies, have been the means of preserving to our days a number of examples of jewellery of all times and all peoples sufficient to illustrate the nature of their ornament and the style of jewellery they wore. In this way examples of the jewels of the ancient Egyptians remain to the present day, from which we learn that the civilised people of the Nile valley even in very early times had greatly improved on the arts of our prehistoric ancestors of the bronze period. For we find the Egyptian artificers could engrave, chase, solder, enrich with enamel, and set precious stones in their jewellery; they were in fact complete masters of the most important processes of the modern jeweller. The jewellery of ancient Greece shows that perfection of form and purity of ornament which was only to be expected of the most highly gifted artistic race of all times. The jewellery of the Romans was, like their art, inherited from the Greeks, and partook of their more robust but less refined character; but with the lapse of time and the influence of northern incursions it modified into Gothic forms. Contemporary with Greek art of the best period, the jewellery of the Etruscans forms the most remarkable example of fine metal-working of ancient times. The Etruscan

jewellers were able to produce on the surface of their gold a rich granulated appearance, as if it were dusted over in a perfectly equal manner with gold powder, which it has long been the despair of jewellers to imitate. About 1860 the late Alessandro Castellani, of Rome, discovered at St Angelo, among the Calabrian mountains, a race of peasant gold-workers who appeared to have inherited the traditional secret; and with the aid of these craftsmen he succeeded in producing fairly satisfactory reproductions of the marvellously fine work of the ancient Etruscans; but, after patient experiment, Castellani himself acknowledged the Etruscan method to be still a lost art. Not less noteworthy is the jewellery of the Celtic and Scandinavian races, which shows remarkable vigour and individuality of character. It is best seen in the ancient brooches of the Scottish Highlands and Ireland, in which the arts of engraving, inlaying, enamelling, filigree-work, Niello (q.v.), and jewelling all in their turns were made use of in the production of works of art of a highly distinctive character (see BROOCH, Vol. II, p. 478). It is well known that a taste for rich and gorgeous jewellery is one of the most outstanding characteristics of the Hindu; and throughout all classes in the East Indies bright, glittering, and richly-coloured personal decorations are looked on as indispensable. The jewellery of India in its styles and methods of manufacture brings down to our own days traditions of the earliest skilled craftsmanship of the world. No other race of jewellers can with so small a weight of gold produce works of such remarkable airiness, grace, and elaboration as the Hindus. Their skill in Filigree-work (q.v.), the gorgeous colouring of their translucent enamels, and generally their masterly and bold use of colours and bright fragments of stone are in the highest degree admirable. Traditional skill and ancient forms are also perpetuated in the 'peasant jewellery' of the various European communities, which yet show in their purity the styles, combinations, and methods of working in use before the harsh mechanical forms of modern cheap jewellery came in to corrupt taste and supplant simple arts.

The distinction between jewellery of the present day and that of earlier times is found in the fundamental fact that the old work is the creation of the craftsman, while the modern jewel is the product of a manufacturer who adopts all labour-saving machines and appliances for the economical finishing of his wares. The lowest class of jewellery—that which forms the staple of the 'gilt-toy trade' in Birmingham—is made from sheet-copper struck up in dies and moulds by means of the screw-press, then gilt by electro-deposit and adorned with glass pastes in imitation of diamonds and all other precious stones. The cheap and rapid production in limitless numbers of imitation articles is thus secured, but the objects themselves are utterly devoid of artistic significance. To a large extent it is the same with jewellery even of the most expensive description, for although it is not stamped out of the sheet, yet the different portions of the work are allotted to separate workmen who perform their task with mechanical accuracy, but in no case is the whole article at once the conception and the execution of the single individual, as was the case with the work of the ancient jeweller.

The headquarters of the jewellery trade as a manufacturing industry is Birmingham, the city in which nearly all the sham jewellery is manufactured. The district of Clerkenwell, in London, is the centre of the higher-class jewellery trade in the United Kingdom. Silver and pebble jewellery is characteristically Scottish, but a great deal of the cheaper Scottish pebble jewellery is of German

manufacture. The manufacture of bog-oak ornaments is a speciality of Dublin, and Jet (q.v.) jewellery is chiefly made at Whitby. All towns of any considerable importance are also centres of jewellery trade; but outside the United Kingdom Paris, Vienna, and New York are the most important places of production. Malta has acquired a reputation for filigree-work; and red coral jewellery comes largely from Naples. See also PRECIOUS STONES.

See Emmanuel, *Diamonds and Precious Stones* (1865); Jones, *History and Mastery of Precious Stones* (1880); Chaffers, *History of English Goldsmiths* (1881); Gee, *The Goldsmith's Handbook* (1881), and his *Hall-marking of Jewellery* (1882); Barbat, *Guide Pratique du Joaillier* (1884); Fontenelle and Malepeyre, *Nouveau Manuel du Bijoutier Joaillier* (1884); Déclé, *Historique de la Bijouterie Française* (1889).

Jews (corrupted from *Jehudim*), the name given, since the Babylonish captivity, to the descendants of the patriarch Abraham, who, about the year 2000 B.C., emigrated from Mesopotamia, on the east side of the Euphrates, to Canaan or Palestine. They were originally called Hebrews (see HEBREW LANGUAGE). In consequence of a famine in Canaan, Jacob, on the invitation of his son Joseph, who had become chief minister of the king of Egypt, went down thither with all his family, which numbered seventy 'souls,' and obtained from Pharaoh permission to settle in the land of Goshen. Here the Hebrews resided, according to Exod. xii. 40, 430 years. According to the genealogical table of the Levites, in Exod. vi. 16-25, however, their sojourn would not have lasted longer than 210 or 215 years; most of the commentators, therefore, take, with Josephus, the 430 years to indicate the period from Abraham to the Exodus (cf. Galat. iii. 17). During the lifetime of Joseph, and probably for some generations afterwards, the Hebrews were well treated, and prospered; but a new dynasty—probably the 19th—arose, and they were reduced to relentless slavery. A deliverer at length appeared in the person of Moses (q.v.). The circumstances of the exodus (about 1320 B.C.)—such as the ten plagues and the crossing of the Red Sea—are a source of continual controversy between the Rationalistic and the Supra-naturalistic schools of biblical criticism; but the *fact* of an exodus would be disputed only by the wildest scepticism.

The wandering in the wilderness of the Sinaitic peninsula is said to have lasted forty years, though a record of the events of two years only has been preserved. These, however, are obviously the most important, as they contain an elaborate account of the giving of the law (Exod. xix. *et seq.*), which is represented as a direct revelation made to Moses by Jehovah Himself, who descended upon Mount Sinai in fire, amid the roar of thunders and the quaking of hills. The antiquity, however, of the priestly or ecclesiastical portions of the Pentateuch is keenly disputed by a rapidly-growing majority of modern scholars, even so orthodox an authority as Fr. Delitzsch having become a convert to their views shortly before his death. The modern school seek to show the probability of such passages having been composed and inserted subsequent to the great organisation of the priesthood by David; and in proof of this point, among other evidences, to the Book of Judges (q.v.), which narrates the history of the Hebrews some 200 years *after* the conquest of Canaan, and which yet contains scarcely a single trace of the existence of Mosaic institutions among them. For the origin of the law as we now have it, the development of the national consciousness, and the growth of the Old Testament literature, see BIBLE. There is a growing tendency among critics to localise the giving

of the law and the various events connected with revelation at Kadesh rather than in the so-called Sinaitic peninsula.

The 'land of promise' became theirs at last (about 1274 B.C.), under Joshua (q.v.), the successor of Moses. Tribe after tribe was swept from its ancient territory, and for the most part either annihilated or forced to flee. Yet the whole bulk of the native inhabitants was not extirpated or expelled, nor even subdued till a much later period. The country was now divided among the Hebrew tribes. The magnificent pastoral region to the east of the Jordan was now occupied by the tribes of Reuben, Gad, and the half-tribe of Manasseh; while the land west of the Jordan was parcelled out to the remaining—Judah, Simeon, Dan, Benjamin, Ephraim, the second half-tribe of Manasseh, Issachar, Zebulon, Naphtali, and Asher. The tribe of Levi received, instead of a province, forty-eight cities scattered throughout Canaan and the tenth part of the fruits of the field, and were allowed generally to settle individually throughout the land where they chose.

After the death of Joshua (about 1254 B.C.) the want of a chief to the young state became sadly palpable. Little regard was paid to the Mosaic institutions; the single tribes pursued their own individual interests; intermarriages with the idolatrous natives weakened the bond of union still further; and the next consequence was that the tribes were singly subdued by the surrounding nations. At this juncture there arose at intervals valiant men and women, Judges (*Shofetim*), who liberated the people from their oppressors, the Moabites, Philistines, Ammonites, Amalekites, &c. Fifteen of these are named, some of whom appear to have been contemporary with each other, and to have exercised authority in different parts of the country. This period constitutes the 'heroic' age of Hebrew history. Among these Judges the prophetess Deborah, Gideon, Jephthah, the herculean Samson, and the prophet Sammel are especially notable; the last mentioned was, in every sense of the word, the greatest Hebrew that had as yet appeared since the days of Moses. The first of the prophets, he was also the last of the republican chiefs of the confederate tribes. Wearied of their intestine feuds, harassed by the incursions of their predatory neighbours, chiefly, however, goaded by the characteristic desire 'to be like all the other nations' (1 Sam. viii. 5), the people compelled him, in his old age, to choose for them a king (1067 B.C.).

The first who exercised regal authority was Saul, the Benjamite (1067-1055 B.C.). But, though a distinguished warrior, and a man of royal presence, he appears not to have possessed the mind of a statesman; and his wilfulness and paroxysms of insanity finally alienated from him many of the bravest and best of his subjects. After his death on Mount Gilboa, David (q.v.), his son-in-law, was proclaimed king (1055-1015 B.C.). This monarch was by far the greatest that ever sat on the throne of Israel. His reign, and that of his equally famous son, Solomon, are regarded as the golden time of Hebrew history. The remaining aborigines of Canaan and its borders

viz. the Philistines, Edomites, Amalekites, Moabites, &c. were thoroughly subdued; the boundaries of the Hebrew kingdom were extended as far as the Euphrates and the Red Sea; Jerusalem was captured, and made the capital of the conqueror; the priesthood was reorganised on a splendid scale; the arts of poetry, music, and architecture were cultivated; schools of prophecy (first established, probably, by Samuel) began to flourish; a magnificent temple for the worship of Jehovah was built in the capital; and commercial intercourse was

carried on with Phœnicia, Arabia, Egypt, with India and Ceylon, and perhaps with even Sumatra, Java, and the Spice Islands. But there was a canker at the root of all this prosperity. The enormous and wasteful expenditure of Solomon forced him to lay heavy taxes on the people. His wealth did not enrich them; it rather made them poorer; and although gifted with transcendent wisdom and the most brilliant mental powers, towards the end of his life he presents the sad spectacle of a common eastern despot, voluptuous, idolatrous, occasionally even cruel, and his reign (1015-977 B.C.) cannot but be regarded, both politically and financially, as a splendid failure. After his death the Hebrew monarchy, in which the germs of dissension—chiefly jealousy against the influence of Judah—had been silently growing up for many a year, split under Rehoboam into two sections (975 B.C.)—the kingdom of Judah, under Rehoboam, son of Solomon, and the kingdom of Israel, under Jeroboam, the Ephraimite. The former of these countries comprised the two tribes of Judah and Benjamin, together, probably, with some Danite and Simeonite cities; the latter, the remaining ten. After nineteen kings of different dynasties, among whom Jeroboam, Abiah, Joram, Jeroboam II., Pekah may be mentioned, had reigned in Israel, few of whom succeeded to the throne otherwise than by the murder of their predecessors, the country was finally conquered by Sargon, king of Assyria, its sovereign, Hoshea, thrown into prison, the mass of the people carried away captive (720 B.C.) into the far east, the mountainous regions of Media, and their place supplied by Assyrian colonists. These, mingling and intermarrying with the remnant of the Israelites, formed the mixed people called Samaritans (q.v.). Among the twenty kings of the House of David who ruled over Judah, Jehoshaphat, Uzziah, Hezekiah, and Josiah distinguished themselves both by their abilities as rulers and by their zeal for the worship of Jehovah. Yet even they were, for the most part, unable to stay the idolatrous practices of the people, against which the prophets' voices even could not prevail. Other kings were, for the most part, more or less unfaithful themselves to the religion of their fathers, and unable to withstand the power of the Egyptians, Assyrians, and Babylonians, to each of whom they in turn became tributary, until at last Nebuchadnezzar stormed Jerusalem (588 B.C.), plundered and burned the temple, put out the eyes of King Zedekiah, and carried off the most illustrious and wealthy of the inhabitants prisoners to Babylon. The Israelites, who had been exiled 134 years before the inhabitants of Judah, never returned. What became of them has always been matter of vaguest speculation (see BABYLONISH CAPTIVITY, ANGLO-ISRAELITE THEORY, BENI-ISRAEL).

All that we know of the condition of the Hebrews during the captivity relates exclusively to the inhabitants of the Kingdom of Judah. And so mild, especially during the later years, was the treatment which they received in the Babylonian empire that, when liberty was announced to the whole body of the captives, only the lowest of the low returned, together with the Levites and Priests. The Book of Esther likewise bears testimony to the numbers that had remained scattered over the vast empire.

The influence of this exile, however, was of a most striking and lasting nature. Babylon henceforth became, and remained up to about 1000 A.D., the 'second land of Israel'—in many respects even more highly prized than Palestine. To this brief period of the captivity must be traced many of the most important institutions of the synagogue in its wider sense. Common religious meetings, with

prayer, were established; many of the Mosaic laws were re-enforced in their primitive rigour; and the body of the 'oral law' began to shape itself, however rudely, then and there. Besides, there began to grow up and unfold itself the belief in a Messiah, a Deliverer, one who should redeem the people from their bondage. The writer of the last twenty-seven chapters of Isaiah, who is usually called by modern scholars the 'Younger Isaiah,' is held to belong to this period, and expresses in glowing language the hopes of the exiles; no less do many of the Psalms belong to this time. From this period, likewise, the belief in the resurrection of the body and the immortality of the soul, as well as the notion of angels and demons, begins to enter more distinctly into the general creed.

The exile is generally computed to have lasted seventy years. This is not strictly correct; it lasted seventy years if reckoned from the capture of Jerusalem in the reign of Jehoiakim (606), but only fifty counting from the destruction of Jerusalem. When Cyrus, the Persian king, had overthrown the Babylonian kingdom (538 B.C.) he issued an edict permitting the exiles to return home; and a minute account of the circumstances attending this joyous event is given in the Books of Ezra and Nehemiah.

The foundations of the Second Temple were laid in the second year of the return, but in consequence of the interference of the Samaritans the work had to be laid aside. It was not resumed till the second year of Darius Hystaspes (520 B.C.), and was finally completed in the sixth year (516 B.C.). The waste cities were likewise rebuilt and re-peopled. During the long reign of Darius the Jews were blessed with a high degree of material prosperity. Under his successor, Xerxes, probably occurred the incidents recorded in the Book of Esther. In the seventh year of Artaxerxes, the successor of Xerxes, Ezra the priest, invested with high powers, headed a second migration. Thirteen years later Nehemiah, Artaxerxes' cup-bearer, but a man of Jewish family, was ordered to proceed to Jerusalem, and, aided by Ezra and others, succeeded in secretly fortifying the city, notwithstanding the continuous opposition from Samaritans, Ammonites, and Arabians. The strictest observance of the 'written law,' even of those of its parts which had been for some reason or other disregarded, was now rigorously enforced, and many 'oral ordinances' were put into practice which do not seem to have been much heard of previously. The supreme spiritual authority was vested in a society of pious and pre-eminently learned men, founded by Ezra, out of which grew the 'Great Synagogue.' The compilation and transcription of the sacred records began, periodical public readings and expoundings of the law were instituted, and the vast Targumic, as well as the so-called rabbinical literature, generally dates—in its earliest beginnings—from this point. During the life of Nehemiah the breach between the Jews and Samaritans became final, by the erection on Mount Gerizim (q.v.) of a rival temple to that at Jerusalem, and the creation of a rival priesthood.

Alexander the Great, on his way to conquer the whole East, did not deem it necessary to storm Jerusalem. The inhabitants submitted (332 B.C.), and he even deigned to have sacrifices offered on his behalf to the national god of his new subjects, a great number of whom, and of Samaritans, he carried away to Egypt, and with these Jewish captives peopled a third of his newly founded city Alexandria. After him Ptolemy Soter, one of his generals, who had become king of Egypt, invaded Syria, took Jerusalem (301 B.C.), and carried off 100,000 of the inhabitants, whom he forced to settle chiefly in Alexandria and Cyrene.

The Egyptian or Alexandrian 'Dispersion' (*Golah*)—destined to be of vast importance in the development of Judaism and Christianity—gradually spread over the whole country, from Libya to Ethiopia. They enjoyed equal rights with their fellow-subjects, both Egyptian and Greek, and were admitted to the highest dignities and offices, so that many further immigrants followed of their own free-will. The freedom they enjoyed enabled them to reach, under Greek auspices, the highest eminence in science and art. To this period belongs the Greek translation of the Bible, the Septuagint (q.v.), which, in its turn, while it estranged the people more and more from the language of their fathers, gave rise to a vast pseudo-epigraphical and apocryphal literature, not to mention the peculiar Græco-Jewish philosophy, which sprang from a mixture of Hellenism and Orientalism.

For a hundred years Judea herself remained under Egyptian rule. During the reigns of the first three Ptolemies it prospered; but after the accession of Ptolemy Philopator a change for the worse came over the fortunes of the Jews. After his death Antiochus III. (q.v.) of Syria incorporated Palestine with the dominions of the Seleucids, and treated the Jews less favourably than their Egyptian masters had done. Their fate became harder still under his son, Antiochus Epiphanes, or Epimanes ('the Madman'), who, by every means a cruel and foolish policy could devise, outraged the religious feelings of the nation. To force the Jews into the Greek religion, the temple at Jerusalem was dedicated to Jupiter Olympius; idol altars were built in every village, and the people constrained to offer swine daily. Some yielded, many fled, the greater part preferred martyrdom in some shape or other.

At this juncture the heroic family of Mattathias, a priest of the house of the Hasmoneans, rose, together with a few patriots, against the immense power of the Syrians. The national cause quickly gathered strength, and after the death of Mattathias (166 B.C.) Judas Maccabæus (q.v.) led the national hosts to victory against the Syrians. After his death (161) his brothers Jonathan and Simon completed the work of deliverance, and instituted the Sanhedrin (145). During their rule alliances were twice formed with the Romans, and the country once more began to prosper. Under Simon more especially, Syrian rule became a mere shadow: his was an almost absolute power, so much so that in the year 170 of the Seleucidian era (142 B.C.) a new Jewish era was commenced, and public documents bore date, 'In the first year of Simon, high-priest and chief of the Jews.' Simon's son, John Hyrcanus (q.v.), after a brief period of vassalage to the Syrians, extended his authority over Samaria, Galilee, and Idumea—the Idumeans being converted to the Jewish religion. His son, Aristobulus, added Iturea to his dominions; Alexander Jannæus, succeeding his brother, further contrived to enlarge his territories. He was disliked by the mass of his countrymen, and a civil war of six years' duration ensued. His wife, Alexandra, securing the support of the Pharisees (q.v.), governed, on the whole, prudently for nine years. The Pharisaic party, however, abused the power which fell into their hands, and a reaction took place. Aristobulus, youngest son of the queen, marched to Jerusalem, and ejected his elder brother, Hyrcanus II., from the sovereignty. This led to the interference of the Romans, who were then fighting both in Syria and Armenia. Jerusalem was captured (63 B.C.) by Pompey, Judæa made dependent on the Roman province of Syria, and Hyrcanus appointed ethnarch and high-priest.

In 54 B.C. Licinius Crassus plundered the temple,

which Pompey had spared. When the war between Cæsar and Pompey broke out, the partisans of Pompey were numerous in Syria, and contrived to poison Aristobulus and execute his son Alexander, who were Casareans (49 B.C.). After the death of Pompey, however, things changed; and Hyrcanus, or rather Antipater the Idumean (who was both his minister and master), saw the necessity of securing the favour of Cæsar. With Hyrcanus II. ended the line of the *Hasmonean* princes. They were nominally both sovereigns and high-priests; but the real religious authority had passed into the hands of the priesthood, and especially of the Sanhedrin (q.v.). The *Idumean* dynasty virtually commenced with Antipater, who prevailed on Cæsar to restrict Hyrcanus to the high-priesthood, and obtained for himself the office of procurator of Judæa, while his eldest son Phazael was appointed governor of Jerusalem, and his younger son Herod governor of Galilee. The Jewish or national party took alarm at this sudden increase of Idumean power; strife ensued, and ultimately Antipater perished by poison; but Herod, by the assistance of the Romans, finally entered Jerusalem in triumph (37 B.C.), caused Antigonus, the last male representative of the *Hasmonean* line, and his most dangerous enemy, to be put to death, and commenced the difficult task of governing a people who were growing more and more unruly every day. For the history of the next period, see HEROD. After Herod's death (4 B.C.), Archelaus, one of his sons, ruled Judæa and Samaria; but his arbitrariness, and still more his constant attacks upon religion, made him hateful to the people; and Augustus, listening to their just complaints, deprived him of his power, and banished him to Vienne. Judæa was now thrown together with Syria, and was ruled by Roman governors.

In the year 38 A.D. the Emperor Caligula issued an edict ordering divine honours to be paid to himself. Everywhere throughout the Roman dominions the Jews refused to obey. At Alexandria a frightful massacre took place, and for a time it seemed as if the whole of the inhabitants of Judæa, too, were doomed to perish. Herod Agrippa obtained anew from Claudius the dominion over all the parts once ruled by his grandfather Herod, and many privileges were through his influence granted to his Jewish subjects, and even to foreign Jews. They received the rights of Roman citizenship (41 A.D.), and their ruler even tried to conciliate their religious prejudices by the strictness with which he observed their law; yet the national party remained discontented, and in an almost permanent state of mutiny.

After the death of Herod Agrippa I. the country was again subjected to Roman governors. The confusion soon became indescribable. The whole land was overrun with robbers and assassins, some of whom professed to be animated by religious motives, while others were mere ruffianly freebooters and cut-throats; the antipathy between Jews and Samaritans waxed fiercer and fiercer, and the latter waylaid and murdered the orthodox Galileans as they went up to worship at Jerusalem; all sorts of impostors, fanatics, and pretenders to magic made their appearance; the priesthood was riven by dissensions; the hatreds between the populace and the Roman soldiery (mostly of Græco-Syrian origin), and under the command of cruel procurators, such as Albinus and Gessius Florus, increased; frightful portents (according to Josephus) appeared in the heavens, until, in 66 A.D., in spite of all the precautionary efforts taken by Agrippa, the party of Zealots, also called Sicarii or 'Assassins,' burst into open rebellion, which, after a horrible carnage, was terminated (70 A.D.) by the conquest of Jerusalem by Titus, the destruc-

tion of the temple, and the massacre and banishment of hundreds of thousands of the unhappy people, who were scattered among their brethren in all parts of the world.

The defence of Jerusalem as narrated by Josephus is one of the most magnificent and melancholy examples of mingled heroism and insanity that the world affords. Very considerable numbers of Jews were still allowed to remain in their native country, and for the next thirty years, although both hated and treated with rigour, they appear, on the whole, to have flourished. The Emperor Nerva was as lenient to them as to the rest of his subjects; but as soon as they had attained some measure of political vitality, their turbulent and fanatical spirit broke out anew. Their last attempts to throw off the Roman yoke, in Cyrene (115 A.D.), Cyprus (116), Mesopotamia (118), and Palestine, under Bar-Cochba (q.v.), were defeated after enormous and almost incredible butcheries. The suppression of Bar-Cochba's insurrection (135 A.D.) marks the final desolation of Judæa, and the dispersion of its inhabitants. The whole of Judæa was made like a desert, about 985 towns and villages lay in ashes, 50 fortresses were razed to the ground; the name of Jerusalem itself was changed into *Ælia Capitolina*, and a heathen colony settled in the city, from entering which every Jew was strictly debarred. The hardships to which the unfortunate race were subjected were again alleviated in the reign of Antoninus Pius; Alexander Severus placed Abraham on the same divine level as he did Christ. Heliogabalus, among his many senseless whims, patronised various Jewish practices, such as circumcision and abstinence from swine's flesh; and, generally speaking, from the close of the 2d century till the establishment of Christianity under Constantine (330 A.D.), when their hopes were once more dashed to the ground, the Jews of the Roman empire appear to have thriven astonishingly. In this period falls the redaction of the chief code and basis of the 'Oral Law,' the Mishna, completed by Jehuda Hanassi ('the Prince'), or Hakkadosh ('the Saint'), president of the great school at Tiberias (220); and upon this code were grafted subsequently the two gigantic commentaries or complements, the Palestinian and the Babylonian Gemaras. The Babylonian Jews were even more fortunate than their western brethren, though they did not perhaps attain the meridian of their prosperity till the revival of the Persian, on the downfall of the Parthian empire. Their leader was called 'The Prince of the Captivity' (*Rosh Galutha*), and was chosen from among those held to be descended from the House of David. He lived in great splendour, assuming among his own people the style and state of a monarch. The reputation for learning of the Babylonian schools, Nehardea, Sura, and Pumbeditha, was very great. What their condition was at this time further east we cannot tell, but it seems quite certain that they had obtained a footing in China, if not before the time of Christ, at least during the 1st century.

In Europe the ascendancy of Christianity was baneful to the Jews. Imperial edicts and ecclesiastical decrees vied with each other in the rigour of their intolerance towards this unhappy people. They were prohibited from making converts, and from marrying Christian women; they were burdened with heavy taxes; yet no persecution apparently could destroy the immortal race. In the 4th century they are found in large numbers in Illyria, Italy, Spain, Minorca, Gaul, and the Roman towns on the Rhine; they are agriculturists, traders, and artisans; they hold land; their services, in fact, cannot be dispensed with; Constantine, during whose reign a fierce revolution broke out among the Arians and Jews (353), terms them 'that most

hateful of all people; yet in spite of this they fill important civil and military situations, have special courts of justice, and exercise the influence that springs from the possession of wealth and knowledge. The brief rule of Julian the Apostate even shed a momentary gleam of splendour over their destinies, and secured for them permission to rebuild the temple of Jerusalem. The death of this emperor, however, frustrated their labours, and the rapid increase of ecclesiastical power was hurtful to them in a variety of ways; although the emperors now began to protect them as far as they could. In 418 they were excluded from military service. After the fall of the western empire their fortunes were different in different countries. In Italy, Sicily, and Sardinia they were for a time unmolested; in the Byzantine empire they suffered many oppressions; while in the 6th and 7th centuries the Franks and Spanish Visigoths inflicted on them frightful persecutions.

The sudden volcanic outburst of Mohammedanism in the Arabian peninsula was at first disastrous to the Jews in that part of the world. For several centuries a Jewish kingdom had existed in the south-west of Arabia, called Himyaritis or Homeritis, which was in a flourishing condition in 120 B.C. About 230 A.D. a prince of the Jewish faith mounted the throne of Yemen; twice, however, the Jewish kings were driven from it, and the Christian religion was introduced in that part in 530. At first Jewish tribes around Mecca and Medina entertained opinions favourable to Mohammed as an Arabian chief, but when Islam began to threaten their own faith they rose in arms against its founder. Mohammed proved the stronger; he subdued the Chaibar tribes in 627, and the Arabian Jews were finally removed to Syria. The spread of Mohammedanism through Asiatic Turkey, Persia, Egypt, Africa, and the south of Spain was, nevertheless, on the whole advantageous to the Jews. Excepting accidental persecutions, such as those in Mauritania (in 790) and in Egypt (1010), they enjoyed, under the califs and Arabian princes, comparative peace. In Moorish Spain their numbers greatly increased, and they became famous for their learning as well as for trade. They were counsellors, secretaries, astrologers, and physicians to the Moorish rulers; and this period may well be considered the golden age of Jewish literature. Poets, orators, philosophers of highest eminence arose, and in considerable numbers; and it is a well-established fact that to them is chiefly due through the Arab medium the preservation and subsequent spreading of ancient classical literature, more especially philosophy, in Europe. But in Christendom few and far between were the monarchs who rose above the barbarism of the churches. About the beginning of the 11th century the Byzantine emperor Basil II. renewed the persecution. In Babylonia, too, the califate had passed into the hands of rulers hostile to the Jews; and before the close of the 11th century the Prince of the Captivity had perished on the scaffold, the schools were closed, the best of the community had fled to Spain, and those that remained were reduced to an abject condition, from which they have never risen. In Italy their position was made tolerable by considerable pecuniary sacrifices; here and there at intervals a spirit of Christian intolerance might break out, but they enjoyed for the most part the protection of the popes.

Less favourable was their lot in France. Under the weaker of the Carlovingians the church advanced with imperious strides, and a melancholy change ensued: kings, bishops, feudal barons, and even the municipalities, all joined in cruel persecution. From the 11th to the 14th century their history is

a series of successive massacres. All manner of wild stories were circulated against them; it was said that they were wont to steal the Host, and to contemptuously stick it through and through; to inveigle Christian children into their houses, and murder them; to poison wells; and the like. They were also hated for their excessive usury, though there can be no doubt that the principal blame of this is to be attributed to those whose tyranny, by depriving the Jews of the right to possess land, had compressed their activity into the narrower channels of traffic. Occasionally, however, their debtors, high and low, had recourse to a very easy means of getting rid of their obligations. Thus, Philip Augustus, under whose rule the Jews seem to have held mortgages of enormous value, simply confiscated the debts due to them, forced them to surrender the pledges in their possession, seized their goods, and banished them from France. Yet in less than twenty years the same proud but wasteful monarch was glad to let them come back. Louis IX. cancelled a third of the claims which the Jews had against his subjects, 'for the benefit of his soul.' An edict was also issued for the seizure and destruction of their sacred books; and we are told that at Paris twenty-four cart-loads of the Talmud and other books were consigned to the flames. In the reign of Philip the Fair the Jews were again expelled from France (1306) with the usual accompaniments of cruelty; but the state of the royal finances rendered it necessary, in little more than a dozen years, to recall them; and they were allowed to enforce payment of the debts due to them, on condition that two-thirds of the whole should be given up to the king! But a religious epidemic having seized the common people in Languedoc and the central regions of France (1321), they signalled themselves by horrible massacres of the detested race. In the following year the plague broke out, and the wildest crimes were laid to the charge of the Jews. One shudders to read what followed; in whole provinces every Jew was burned, and at Chinon a hundred and sixty of both sexes were burned together! Christianity never produced more resolute martyrs; they sang hymns in the place of torment. Finally, in 1395, they were banished from the centre of France.

In England they are mentioned in the ecclesiastical constitutions of Egbert, Archbishop of York, in 740; they are also named in a charter to the monks of Crowland, 833. William the Conqueror and William Rufus favoured them; the latter carried his contempt for the religious institutions of his kingdom so far that he actually farmed out the vacant bishoprics to Jews; and at Oxford, even then a seat of learning, they possessed three halls—Lombard Hall, Moses Hall, and Jacob Hall, where Hebrew was taught to Christians as well as to the youths of their own persuasion. As they grew in wealth they grew in unpopularity. On the day of the coronation of Richard the Lion-Heart (1189), some Jews being found present at the spectacle, from which their nation had been strictly excluded, a popular commotion against them broke out in London; their houses were pillaged and burned; and though Ranulf de Glanvill, the chief-justiciary of the realm, partially succeeded in arresting the havoc, and even in bringing some of the mob to justice (three were hanged), yet the barbarous bigotry of priests and people prevented anything like just or salutary punishment. Similar scenes were witnessed at Norwich, Edmundsbury, Stamford, and York; in York most of the Jews preferred death to forced baptism. When Richard returned from Palestine their prospects brightened a little; though they still were treated with great rigour, their lives and wealth were protected for a consideration! John at first

covered them with honour, but suddenly turned round on his protégés, after they had accumulated great wealth, and imprisoned, maltreated, and plundered them in all parts of the country. Under Henry III. they were mulcted enormously. Accused of clipping the coin of the realm, they had, as a penalty, to pay into the royal exchequer (1230) a third of their movable property. To this reign belongs the now exploded story of the crucifixion of the Christian boy, Hugh of Lincoln (q.v.). The accession of Edward I. did not mitigate their misery; some efforts were made to induce them to give up their profession of usury, as was also done in France and elsewhere during the same period; but, heavily taxed by the sovereigns or governments of Christendom, and debarred by special decrees or by vulgar prejudice from almost every other trade or occupation, they could not afford to prosecute ordinary callings. The attempt made by the Dominican friars to convert them, of course, failed utterly; and in 1253, the Jews—no longer able to withstand the constant hardships to which they were subjected in person and property—begged of their own accord to be allowed to leave the country. Richard of Cornwall, however, persuaded them to stay. Ultimately, in 1290, they were driven from the shores of England, pursued by the execrations of the infuriated rabble, and leaving in the hands of the king all their property, debts, obligations, and mortgages.

In Germany they were looked upon as the special property of the sovereign, who bought and sold them, and were designated his *Kammerknechte* ('chamber-servants'). About the 8th century they are found in all the Rhenish towns; in the 10th century, in Saxony and Bohemia; in the 11th, in Swabia, Franconia, and Vienna; and in the 12th, in Brandenburg and Silesia. The same sort of treatment befell them in the empire as elsewhere; they had to pay all manner of iniquitous taxes—body tax, capitation tax, trade taxes, coronation tax—and to present a multitude of gifts to mollify the avarice or supply the necessities of emperors, princes, and barons. A raid against the Jews was a favourite pastime of a bankrupt noble in those days. The Crusades kindled a spirit not in Germany only, however, but through all Christendom, hostile to the 'enemies of Christ.' Trèves, Metz, Cologne, Mainz, Worms, Spire, Strasburg, and other cities were deluged with the blood of the 'unbelievers.' At such epochs the passions of the populace and of the lower clergy could not be restrained. The word *Hep* (said to be the initials of *Hiccosolyqua est perdita*, 'Jerusalem is fallen') throughout all the cities of the empire became the signal for massacre, and if an insensate monk sounded it along the streets it threw the rabble into paroxysms of murderous rage. The Jews were expelled from Vienna (1196), Mecklenburg (1225), Frankfort (1241), Brandenburg (1243), Nuremberg (1390), Prague (1391), and Ratisbon (1476). The 'Black Death' occasioned a great and widespread persecution (1348-50). They were murdered and burned by thousands, and the race almost disappeared from Germany; only, however, to return, for their services were indispensable. Here and there they possessed the rights of citizens, or were allowed to hold real estate; in general they were permitted to prosecute only commerce and usury, and the law turned on them its harshest aspect. Repeatedly, too, the emperors gratified at once their piety and their greed by cancelling their pecuniary claims. In many places they were compelled to live in certain parts of the town, known as the *Judenstrasse* ('Jews' Street').

Switzerland commenced to persecute them about

the middle of the 14th century; in the 15th century they were expelled from various places. Their treatment was more humane in Poland and Lithuania; and after 1348 their numbers there were swelled by fugitives from Germany and Switzerland. Russia and Hungary received, persecuted, and banished them.

In Spain the condition of the Jews was long highly favourable; but the horrible persecutions by the Gothic princes in the 6th and 7th centuries made it inevitable that the first gleam of a Moorish scimitar on the coast would turn them into allies of the invaders. During the whole of the brilliant period of Moorish rule in the peninsula they enjoyed, indeed, what must have seemed to them, in comparison with their fate elsewhere, a sort of Elysian life. They were almost on terms of equality with their Mohammedan masters, rivalled them in civilisation and letters, and probably surpassed them in wealth. The Spanish Jews were consequently of a much higher type than their brethren in other parts of Europe. They were not reduced to the one degrading occupation of usury, though they followed that too; on the contrary, they were husbandmen, landed proprietors, physicians, financial administrators, and they had courts of justice for themselves. The Christian monarchs of the north and centre also came to appreciate the value of their services, and we find them for a time protected and encouraged by the rulers of Aragon and Castile. But the extravagance of the nobles and the increasing power of the priesthood ultimately brought about a disastrous change. The estates of the nobles were in many cases mortgaged to the Jews; hence it was not difficult for 'conscience' to get up a persecution. Gradually the Jews were deprived of the privilege of living where they pleased; their rights were diminished and their taxes augmented. In Seville, Cordova, Toledo, Valencia, Catalonia, and the island of Majorca outbursts of priestly and popular violence took place (1391-92); immense numbers were murdered, and wholesale theft was perpetrated by the religious rabble. Escape was possible only by flight to Africa, or by accepting baptism at the point of the sword. The number of these enforced converts to Christianity is reckoned at 200,000. The fate of the Jews in Spain during the 15th century, however, beggars description; we read of nothing but persecution, violent conversion, massacre, the tortures of the Inquisition. Thousands were burned alive; and in one year 280 were burned in Seville alone. Sometimes the popes, and even the nobles, shuddered at the fiendish zeal of the inquisitors, and tried to mitigate it, but in vain. At length the hour of final horror came. In 1492 Ferdinand and Isabella issued an edict for the expulsion within four months of all who refused to become Christians, with the strict prohibition to take neither gold nor silver out of the country. The Jews offered an enormous sum for its revocation, and for a moment the sovereigns hesitated; but when Torquemada, the Dominican inquisitor-general, compared them to Judas, they shrank from the awful accusation; and the ruin of the most industrious, the most thriving, the most peaceable, and the most learned of their subjects—and consequently of Spain herself—became irremediable. Not less than 300,000 resolved to abandon the country, which a residence of seven centuries had made almost a second Judaea to them. The incidents that marked their departure are heartrending. Almost every land was shut against them. Some, however, ventured into France; others into Italy, Turkey, and Morocco, in the last of which countries they suffered the most frightful privations. Of the 80,000 who obtained an entrance into Portugal for

eight months on payment of eight gold pennies a head, many lingered after the expiry of the appointed time, and the poorer were sold as slaves. In 1495 King Emanuel commanded them to quit his territories, but at the same time issued a secret order that all Jewish children under fourteen years of age should be torn from their mothers, retained in Portugal, and brought up as Christians. Agony drove the Jewish mothers into madness; they destroyed their children with their own hands, and threw them into wells and rivers to prevent them from falling into the hands of their persecutors. The miseries of those who embraced Christianity, but who, for the most part, secretly adhered to their old faith (*Oussim, Auussim*, 'yielding to violence, forced ones'), were hardly less dreadful, and it was far on in the 17th century before persecution ceased. *Jatos da Fé* of suspected converts happened as late as 1655.

The wanderers appear to have met with much better treatment in Italy and Turkey than anywhere else. During the 15th and 16th centuries they are to be found in almost every city of Italy, pursuing various kinds of traffic (nearly the whole trade of the Levant, for instance, was in their hands); but chiefly engaged in money-lending, in which they rivalled the great Lombard bankers. Abarbanel (q.v.), perhaps the most eminent Jewish scholar and divine of his day, rose to be confidential adviser to the king of Naples. In Turkey they were held in higher estimation than the conquered Greeks; they were allowed to reopen their schools, to establish synagogues, and to settle in all the commercial towns of the Levant.

The invention of printing, the revival of learning, and the Reformation are generally asserted to have been beneficial to the Jews, but this is only partially true. When the Jews began to use the presses at their earliest stage for their own literature, sacred and otherwise, the Emperor Maximilian was urged—chiefly by converts—to order all Hebrew writings to be committed to the flames; and, but for the strenuous exertions of Reuchlin (q.v.), ignorance, treachery, and bigotry might have secured a despicable triumph. Luther, in the earlier part of his career, looked with no unfavourable eye on the adoption of violent means for their conversion; on the other hand, Pope Sixtus V. was animated by a far more wise and kindly spirit towards them than any Protestant prince of his time. In 1588 he abolished all the persecuting statutes of his predecessors, allowed them to settle and trade in every city of his dominions, to enjoy the free exercise of their religion, and, in respect to the administration of justice and taxation, placed them on a footing of equality with the rest of his subjects. That the Reformation itself had nothing to do with subsequent ameliorations in the condition of the Jews is only too plain from the fact that in many parts of Germany, Protestant as well as Catholic, their lot became actually harder than before. They were driven out of Bavaria (1553), out of Brandenburg (1573); and during the whole of the 17th and the first part of the 18th century the hardships inflicted on them by the German governments positively became more and more grievous. What really caused the change in their favour was the great uprising of human reason that marked the middle of the 18th century. Among the writers who distinguished themselves in Germany by pleading the cause of the Jews we may specially mention Lessing and Mendelssohn. In Holland the Jews were permitted as early as 1603 to settle and trade, though they did not acquire the rights of citizenship till 1796.

In England the edict of Edward I. remained in force for more than 300 years; and the first attempt made by the Jews to obtain a legal recognition

in that country was during the Protectorate of Cromwell in 1655. Cromwell himself was favourable to their admission; so were the lawyers; but the nation generally, and particularly the religious portion of it, were strongly hostile to such a proceeding; and the wearisome controversial jangling of the divines appointed to consider the question prevented anything from being done till the reign of Charles II., who, standing much and frequently in need of their services, permitted them quietly to settle in the island. The English legislature first commenced to take special notice of the existence of Jews in the first half of the 18th century. In 1723 they were distinctly recognised as British subjects in an act which permitted them, when giving evidence in a court of justice, to omit from their oath the words 'On the true faith of a Christian.' In 1753 they obtained the right of naturalisation, but in deference to public clamour it had speedily to be revoked. Most of the civil and political rights of the Jews have been accorded them during the present century. Until 1828 the number of Jewish brokers in the City of London—all of whom were heavily taxed—was limited to twelve. A Jew could not be admitted to the freedom of the City, or exercise any retail trade, till 1832. Since 1833 the profession of barrister, since 1835 the shrievalty, and since 1845 the office of alderman and of lord-mayor have been opened to them. During the reign of Queen Victoria almost every Jewish disability has been removed, so that, in point of law, Jews are now, if natural-born subjects, on practically the same footing as English subjects. By an act of 1845 they were allowed to hold offices in municipal corporations, on condition of signing a declaration (in place of the usual oath) not to exercise their influence so as to injure or weaken the Protestant Church. The privileges of this act were extended by one of 1858, whereby Jews are entitled to be admitted to municipal and other offices on taking the oath, omitting from it the objectionable formula. In 1846 they were placed, as regards their schools and places of worship, of education, and charities, on the same footing as Protestant dissenters. In 1871 the Universities Tests Act was passed, which enabled Jews to graduate at the ancient universities without detriment to their religious principles. Before 1845 doubts had prevailed whether the marriages previously celebrated in England among the Jews, according to their own usages, were valid, and the statute of 1847 put an end to such doubts by declaring all such marriages valid, provided both the parties married had been persons professing the Jewish religion. But now, as then, though it is competent for Jews, like other dissenters, to superadd any religious ceremony they please to their marriages, there must in all cases be notice given to the registrar of the district of such marriage being about to take place, the only exemption being that the marriage may be celebrated in the synagogue or any ordinary dwelling, and not, as with other denominations, in the superintendent registrar's office, or a registered building. A license may also be procured from the superintendent registrar, and the secretaries of the respective synagogues are recognised as the persons to keep the register books of Jewish marriages. In Scotland there is no peculiar legislation affecting Jewish marriages. It was not until 1858 that Jews were admitted to parliament, a statute of that year empowering the House to modify the oath required of members, by omitting in the case of Jews the concluding words of the oath. Baron Rothschild was the first who took his seat in the House of Commons on the passing of this act. But even this statute was only permissive, it being

still left in the power of parliament to refuse to modify the oath if it so determined. It was accordingly superseded by an act of 1866, which prescribed a uniform oath to be taken by members of all religious denominations, except Quakers and other Separatists, who might claim to be admitted by affirmation. Jews were first admitted to the Upper House in 1885, when Sir N. M. de Rothschild was elevated to the peerage as Lord Rothschild, taking the oath, *more Judaico*, with his head covered. The very highest offices of the state are now, with scarcely an exception, within the reach of Jews. Unlike Roman Catholics, Jews may present to livings in the Church of England. But whenever a Jew holds any office in the gift of Her Majesty, to which office shall belong the right of presentation to any ecclesiastical benefice, such right of presentation devolves upon the Archbishop of Canterbury for the time being.

Some of the relics of that mighty host of exiles that left Spain and Portugal found their way into France, where they long lingered in a miserable condition. In 1559 they were received into Bayonne and Bordeaux; they were also to be found in considerable numbers in Avignon, Lorraine, and Alsace. In 1784 the capitation tax was abolished. In 1790, while the French Revolution was still animated by a sincere humanitarianism, the Jews presented a successful petition to the national representatives, Mirabeau being among their advocates. From this time their technical designation in France has been *Israelites*. In 1806 the Emperor Napoleon summoned a 'Sanhedrin' of Jews to meet at Paris, to whom a variety of questions were put, mainly with a view to test their fitness for being French citizens. Since then they have been found not only in the highest offices of the civil administration—very frequently in the ministry (e.g. Crémieux, Gondechaux, Fould)—but they have also filled some of the chief places in the army and navy. We may add here that their bravery in the field has been the subject of frequent remark—although among the vices with which a brutal prejudice loved to brand them, in spite of all historical evidence, was also that of cowardice.

In Denmark since 1814 they have been on a footing of equality as citizens with native Danes. To Sweden they were first invited—the invitation only extending to the rich—in 1746. Norway forbade them to touch its soil till 1800. Admitted into Russia by Peter the Great, they were expelled by the Empress Elizabeth in 1743. Readmitted by the Empress Catharine II., they were further protected by the Emperor Alexander I., who in 1805 and 1809 issued decrees insuring them full liberty of trade and commerce; Nicholas withdrew these privileges. In 1881 a violent agitation against the Jews, accompanied by much outrage and bloodshed, took place in the south and west of Russia, and also in Warsaw. Their residence is strictly confined to certain parts of the empire. Some 225,000 were driven out by further restrictions in 1892, and many were then and later settled in Argentina and elsewhere by Baron Hirsch. In Poland they are more numerous than in any other part of the world. They owed their first humane reception in the 14th century to the love which King Casimir the Great bore for a Jewish mistress. For many years the whole trade of the country was in their hands. During the 17th and the greater part of the 18th century, however, they were much persecuted, and sank into a state of great ignorance, and even poverty; but education—in spite of the severity and barbarism of Russian intolerance—has, since the French Revolution, made progress among them. Frederick the Great, king of Prussia, showed himself singularly harsh towards the Jews; his legislation almost throws us back

into the middle ages. All manner of iniquitous and ridiculous taxes were laid upon them; only a certain number were allowed to reside in the country, and these were prohibited from both the most honourable and the most lucrative employments. This shameful state of matters was ended by the Prussian edict of toleration (1812), by which Jews were placed almost in an equal position as citizens with other Prussians. Since then the tendency, on the whole, had been to enlarge their 'liberties'—until the revolution of 1848 gained them their full emancipation, although it was slowly carried out. In the smaller German states their full rights were grudgingly conceded. The Reichstag of the empire, like the National Assembly in 1848, now contains many prominent Jewish members. However, the progress of Jewish emancipation in Germany has not, of late years, been continuous. Strange to say, the year 1880 was marked by a remarkable revival of hostility against the Jews, especially in Berlin, which, known as the *Judenhetze*, was encouraged by many persons of standing in society. In Austria the Emperor Joseph II. distinguished himself by passing an act of toleration (1782) extraordinarily liberal in its provisions for the Jews. Not till 1860, however (and even then under certain restrictions), did they acquire the right to possess land. But in 1868 they were accorded the complete liberty which they now enjoy, and which is only overclouded occasionally by outbreaks of Anti-Semitism. In Hungary and Transylvania they have long enjoyed important privileges, and have been protected by the nobility. In Roumania they still suffer much ill-usage, being only nominally protected by the treaty of Berlin. Spain began to tolerate them again in 1837, and they can follow trade or agriculture like other Spaniards. Of late years they have even been allowed to assemble for religious worship. Portugal, where they enjoy no civic rights, has only a few German Jews. Switzerland long treated them harshly, and only of late have steps in the right direction been taken.

In Turkey they are very numerous, and have thriven in spite of the exactions of pashas, the insolence of Janizaries, and the miseries of war. Their communities in Constantinople, Adrianople, Salonica, Smyrna, Aleppo, and Damascus are considerable; in Palestine, their ancient home, they are rapidly increasing, but they are still, in spite of the many efforts on the part of their European brothers to ameliorate their condition, very poor. Their numbers in Arabia are not very large, yet they enjoy some independence. Those in Persia have sunk into ignorance. They are found in Afghanistan, and carry on a trade between Kabul and China; in India and Cochin China, where they are both agriculturists and artisans; in Surinam, where there is a flourishing colony; in Bokhara, where they possess equal rights with the other inhabitants, and are skilled in the manufacture of silks and metals; and in China, where, however, they are very insignificant both in numbers and position. They are also found all along the North African coast, where, indeed, they have had communities for perhaps more than a thousand years, which were largely reinforced in consequence of the great Spanish persecutions. They are numerous in Morocco, though not always secure from the perils of Mohammedan fanaticism. In Egypt and Nubia they are few; in Abyssinia, where they are known as Falashas, more numerous; they exist in the Soudan, and are also found farther south in considerable numbers, the mining industries of the Cape and Transvaal being largely in their hands. America, too, has invited their spirit of enterprise. In the United States, as in Great Britain, they enjoy absolute liberty, and have established some

500 congregations. They have been in Brazil since 1625, and are also settled in some parts of the West Indies.

The present distribution of Jews throughout the world, as calculated in 1888, is as follows: Russia, 3,500,000; Anstro-Hungary, 1,800,000; Germany, 600,000; Rumania, 325,000; Turkey in Europe, 160,000; Holland, 90,000; Belgium, 6000; France, 75,000; Great Britain, 100,000; Italy, 40,000; Switzerland, 8000; Scandinavia, 8000; Servia and Bulgaria, 40,000; Greece, 5000; Iberian Peninsula, 2000—making in all Europe above 6½ millions. To this may be added about 500,000 in Asia, 350,000 in Africa, 500,000 in America, and 20,000 in Australasia. This would bring the total number of Jews in the world up to a little over 8 millions. It should be mentioned, however, that some authorities calculate their number as considerably less than this. They assume about 5½ millions for Europe, and 1¼ million for the rest of the world.

Religion.—Generally speaking, Jews believe in the inspiration of the Old Testament, the authority of the Law of Moses, the absolute unity and incorporeality of the Godhead, the immortality of the soul, the ability of mankind to work out their own salvation without the help of priest, mediator, or sacrifice, and the ultimate conversion of mankind to Theism. Such are the main points of agreement between almost all Jews, but on many questions they are sharply divided. For some two thousand years there have been at least two religious sections. In the time of Christ they were known as Pharisees (Rabbinical Jews) and Sadducees (Biblical Jews); in the middle ages as Rabbanites and Karaites, the Rabbanites being adherents of traditional Judaism, and the Karaites insisting on the literal interpretation of Scripture. Since the early part of the 19th century these differences have to some extent been reproduced in the division of Jews into Orthodox and Reformed. The latter (who may also be styled Progressive or Modern Jews) believe in the divine authority of the Old Testament or 'Written Law' only, while Orthodox (otherwise known as Conservative or Rabbinical) Jews ascribe co-ordinate authority to the 'Oral Law' of the Rabbins, which they regard as the key to the explanation of Holy Writ. The Oral Law is embodied in the Talmud and its commentaries, and is believed by them to have been orally transmitted from Moses to his successors down to the time of Jehuda the Holy or the Prince (see *ante*), when it was first committed to writing. To this main distinction most of the divergencies between Orthodoxy and Reform can be traced. Thus the difference of opinion on such questions as sacrifice, the Messiah, the return to Jerusalem, and the restoration of the national life follows as a corollary from the maintenance or repudiation of the Rabbinical standpoint. A Rabbinical Jew believes in the political reconstitution of his nation, the restoration to Palestine, the rebuilding of Jerusalem and of the temple on Mount Zion, and the rehabilitation of the sacrificial ritual. He also looks forward to the coming of a personal Messiah, a descendant of David, who will assert the independence of his race and accomplish the restoration. Such are the hopes which inspire a great portion of the orthodox liturgy. The Reformed Jew, interpreting Scripture in a free and rationalistic spirit, subscribes to none of these beliefs. The sacrifices ordained in the Pentateuch he regards in the light of a temporary concession of Moses to the barbarous customs of his age, and an institution which, having once fallen into desuetude, will never again be revived; and, in support of this view, he points, not merely to the teaching of Maimonides, but to the frequent denunciation

of sacrificial rites by the prophets and psalmists of Israel. Nor does he believe in the restoration of the national life or the return to Jerusalem. Most commonly, indeed, he is even unwilling to admit that Jews can any longer be considered a nation. Nor does he find any difficulty in explaining away those utterances of the prophets which would seem to point to such a return. Such utterances must either be referred to events in the proximate future, such as the return of the Jews to Palestine under the edict of Cyrus, or they are to be regarded as mere rhetorical declamations or poetical pictures without any definite significance. Similarly with the belief in a personal Messiah. Although this is one of the Thirteen Articles of Faith, as laid down by Maimonides, it is gradually being abandoned by modern Jews, who are inclined to substitute for it the belief in a Messianic age in which, as foretold by the prophets, all mankind will be brought to the knowledge and worship of one God, and war and dissension will cease from the face of the earth. From all this it will be seen that Reformed Judaism not merely interprets Scripture in the light of common sense, but also exhibits a more or less decided leaning to the teachings of Rationalism, some of the more advanced Reformers, indeed (for there are various degrees of reform), being pure Rationalists. Such theories as that of two Isaiahs, or the late date of Daniel and Ecclesiastes, are subscribed to by most educated Jews, but the Wellhausen theory of the Hexateuch is held only by the more advanced section of Reformers. Sometimes it is stated that Orthodox Jews believe in the physical resurrection of the body after death. But this is not correct. It was the view of Jews in the time of Christ, and has long since been superseded by the belief in the immortality of the soul.

The distinction between Orthodoxy and Reform further exhibits itself in ceremonial practices and the ritual of the synagogue. Reformed Jews restrict themselves to the practice of the ceremonial laws laid down in the Pentateuch, with the exception of those which, like the institution of sacrifice, have no application at the present day. Orthodox Jews are expected to obey, besides the legislation of the Pentateuch, the entire body of the Oral Law with its many thousands of minutiae, and the several customs which have become sanctified by age and tradition. These are principally set forth in a digest known as the *Shulchan-Aruch*—the text-book of Orthodox Judaism. As in private practice, so in the public worship of the synagogue, Reformed Jews have simplified the ritual and adapted it to modern needs. They have introduced instrumental music and mixed choirs. In the more advanced synagogues, particularly in America, the service is made to approximate to church practices in three particulars: (1) the sexes sit together in family pews; (2) the heads of male worshippers are uncovered; (3) the service is in the vernacular. In some synagogues (Berlin, Philadelphia, and Chicago) innovation has been carried to the extent of substituting Sunday for the seventh-day Sabbath, while several synagogues in America have Sunday services *in addition* to those held on the Sabbath.

The programme of Judaism put forth by Dr Krauskopf of Philadelphia in 1888 is of so very radical a character as hardly to deserve the title of Judaism. But as the congregation which have adopted it not only call themselves Jews, but are regarded as such by the rest of the community, it must be set down as the ultimate phase of Judaism, marking the limits beyond which it would not be possible for Judaism to travel without merging its identity in Theism or Agnosticism. 'We discard,' says Dr Krauskopf, 'the belief in a

God who is a man magnified, who has his abode somewhere in the inter-stellar spaces. We discard the belief that the Bible was written by God, or by man under the immediate dictation of God, and that its teachings are therefore infallible. . . . We discard the belief in the coming of a human Messiah, who will lead us back to Palestine, establish us as the rulers of the world, and make all nations tributaries to us. We discard the belief in bodily resurrection, hell-torments, Paradise rewards, prophecy, superstitions, all Biblical and Rabbinical beliefs, rites and ceremonies and institutions, which neither elevate nor sanctify our lives.

Literature.—For the Hebrew language, see under that head. The extraordinary influence which the religion of the Hebrews has exercised on Christian and Mohammedan nations has given a universal significance to their ancient literature; but of this we possess nothing which, in its original shape, reaches further back than the period of David. The composition of the extant works in *Hebrew Literature* proper would, on this view, extend over a period of nearly 900 years—viz. from the times of David to those of the Maccabees. This period was preceded by a preparatory one of sagas, songs, fragmentary historical notices, inscriptions, laws, and probably also priestly registers. The extant literature may be arranged under the five heads—law, prophecy, history, lyric poetry, and speculation (see BIBLE, and the articles on the separate books of the Old Testament). The same epoch in which took place the transition from Hebraism to Judaism—the epoch of the captivity—was also that which marked the commencement of *Jewish literature*, properly so called. Founded on the earlier and more creative Hebrew, and for the most part written in the same language, it is yet qualified by the presence of religious conceptions borrowed from the Persians, of Greek wisdom, Roman law, and, at a later period, of Arabic poetry and philosophy, and of European science: though everything is strictly subordinated to the great ideas of the ancient faith. Since the return from exile, the Jewish—also, but erroneously, called the *Rabbinical*—literature has, without the slightest external encouragement, actively taken part in the cultivation of the human mind; and in the results of this activity, which are still far from being duly appreciated, there lie concealed the richest treasures of centuries.

Jewish literature has been divided chronologically into nine periods. The *first period* extends to 143 B.C. After the return from exile the Jewish people naturally enough became animated by an intense nationality of feeling. Expositions and additions to the earlier history (*Midrashim*), as well as Greek translations, were executed, and several of the Hagiographa—such as particular psalms, the so-called Proverbs of Solomon, Ecclesiastes, the Books of Chronicles, portions of Ezra and Nehemiah—were written. To this period also, if to any, must belong the uncertain performances of the *Great Synagogue* (q.v.), to whom the work of completing the canon of the Old Testament is chiefly ascribed. Towards its close (190-170 B.C.) several writers appear in *proprio personâ*, as, for instance, Sirach and Aristobulus. The doctors of whom the Great Synagogue chiefly consisted were called *Sopherim* ('Scribes'). At this time Aramaic finally became the popular dialect of Palestine.

The *second period* extends from 143 B.C. to 135 A.D. The *Midrash* (see EXEGESIS), or the inquiry into the meaning of the sacred writings, was divided into *Halacha* and *Hagada*: the former considered the improvement of the law, with a view to practical results; the latter, the essence of the religious

and historical interpretations. At first both were the oral deliverances of the *Soferim*, but gradually written memorials made their appearance. The public interpretation of the Scripture in schools and synagogues, the independence of the Sanhedrin, the strife of sects, and the influences of Alexandrian culture furthered this development. To this period also belong various Greek, but not, as is still erroneously supposed by some, the *written Targums* or Aramaic versions of the Bible (see TARGUMS), which sprang at a much later period from oral translations of the Pentateuch in the synagogues instituted after the return from the exile: further, the whole of the Apocrypha (q.v.), and the earliest Christian writings, which are at least the productions of men nurtured in the principles of Judaism, and which contain many traces of Judaistic culture, feeling, and faith. It was also characterised by the drawing up of prayers, scriptural expositions, songs, and collections of proverbs. The author of the first book of the Maccabees, Jason, Josephus, Philo, Johannes are names specially worthy of mention: so also are the doctors of the oral law—Hillel (q.v.), Shammai, Jochanan-ben-Zaccai, Gamaliel, Eleazar-ben-Hyrecaus, Joshua-ben-Chananja, Ishmael, Akiba, and others of like eminence. *Rabbi* ('Master') *Talmud Charlam* ('Disciple of Wisdom') were titles of honour given to those expert in a knowledge of the law. Besides the Maccabean coins, Greek and Latin inscriptions belonging to this period are extant.

The *third period* reaches from 135 to 475 A.D. Instruction in the Halacha and Hagada now became the principal employment of the flourishing schools in Galilee, Syria, Rome, and after 219 A.D. in Babylonia; the most distinguished men were the masters of the *Mishna* (q.v.) and the *Talmud* (q.v.)—viz. Eleazar-ben-Jacob, Jehuda, Jose, Meir, Simeon-ben-Jochai, Jehuda the Holy, Nathan, Chija, Rab, Samuel, Jochanan, Hunna, Rabba, Rava, Papa, Ashe, and Abina. Besides expositions, additions to Sirach, ethical treatises, stories, fables, and history were also composed; the prayers were enriched, the Targum to the Pentateuch and the Prophets completed, and the calendar fixed by Hillel the second (340 A.D.). After the suppression of the academies in Palestine, those of Persia—viz. at Sura, Pumbeditha, and Nehardea—became the centre of Jewish literary activity. On Sabbaths and festal days the people heard, in the schools and places for prayer, instructive and edifying discourses. Of the biblical literature of the Greek Jews we have only fragments, such as those of the versions of Aquila and Symmachus. With this period terminates the age of direct tradition.

The *fourth period* (from 475 to 740 A.D.). By this time the Jews had long abandoned the use of Hebrew, and instead had adopted the language of whatever country they happened to dwell in. During the 6th century the Babylonian Talmud was concluded, the Palestinian Talmud having been redacted about a hundred years before. Little remains of the labours of the *Jewish Librari* of the 7th century, or of the earliest *Gemara* or presidents of the Babylonian schools, who first appear in 589 A.D. On the other hand, from the 6th to the 8th century the Masora (q.v.) was developed in Palestine (at Tiberias); and, besides a collection of the earlier Hagadas, independent commentaries were likewise executed, as the *Pesikta*, the *Parke of Elizer* (700 A.D.), &c.

In the *fifth period* (740-1040) the Arabs, energetic, brilliant, and victorious in literature as in war, had appropriated to themselves the learning of Hindus, Persians, and Greeks, and thus excited the emulation of the oriental Jews, among whom now sprung up physicians, astronomers, grammarians, commentators, and chroniclers. Religious

and historical Hagadas, books of morality, and expositions of the Talmud were likewise composed. The oldest Talmudic compends belong to the age of Anan (*circa* 750 A.D.), the earliest writer of the Karaite Jews. The oldest prayer-book was drawn up about 880; and the first Talmudic Dictionary about 900. The most illustrious *Gronim* of a later time were Saadia (died 941), equally famous as a commentator and translator of Scripture into Arabic, a doctor of law, a grammarian, theologian, and poet; Seherira (died 998); and his son Hai (died 1038), who was the author, among other things, of a dictionary. From Palestine came the completion of the Masora and of the vowel-system; numerous *Midrashim*, the Hagiographical Targums, and the first writings on theological cosmogony were also executed there. From the 9th to the 11th century Kairwan and Fez, in Africa, produced several celebrated Jewish doctors and authors. Learned rabbins are likewise found in Italy after the 8th century, as Julius in Pavia. Bari and Otranto were at this time the great seats of Jewish learning in Italy. After the suppression of the Babylonian academies (1040) Spain became the central seat of Jewish literature. To this period belong the oldest Hebrew codices, which go back to the 9th century. Hebrew rhyme is a product of the 8th, and modern Hebrew prosody of the 10th century.

The *sixth* period (1040-1204) is the most splendid era of Jewish medieval literature. The Spanish Jews busied themselves about theology, exegetics, grammar, poetry, the science of law, astronomy, mathematics, philosophy, rhetoric, and medicine. They wrote sermons and ethical and historical works. The languages employed were Arabic, Rabbinical Hebrew, and ancient or classical Hebrew. We can only mention here the great doctor, Samuel Halevi (died 1055), and the renowned Maimonides (q.v.), whose death closes this epoch. The literature of the French rabbins was more national in its character, and kept more strictly within the limits of the Halacha and Hagada. The great Rashi (q.v.), the prince of commentators, whose real name was Solomon-ben-Isaac of Troyes (1040-1105), is one of the greatest names in Jewish literature. In Provence, which combined the literary characteristics of France and Spain, there were celebrated Jewish academies at Lunel, Narbonne, and Nîmes. The fame of the Talmudists of Germany, especially those of Mainz and Ratisbon, was very great. Only a few names belong to Greece and Asia; still the Karaite Jews had a very able writer in Jehuda Halassi (1148). The greater portion of the prayer-book was completed before Maimonides. Many of the works, however, produced between 740 and the close of this period are lost.

The *seventh* period (1204-1492) bears manifest traces of the influence exercised by Maimonides. Literary activity showed itself partly in the sphere of theologico-exegetic philosophy, partly in the elaboration of the national law. With the growth of a religious mysticism there also sprung up a war of opinions between Talmudists, Philosophers, and Cabbalists. The most celebrated Jews of this period lived in Spain; later, in Portugal, Provence, and Italy. To Spain belongs (in the 13th century) the poet Jehuda Charisi. In the 15th century a decline is noticeable. Books written in Hebrew were first printed in Spain at Tzar in Aragon (1485), at Zamora (1487), and at Lisbon (1489). During this epoch the chief ornaments of Jewish literature in Provence were Moses ben-Nachman, David Kimchi, Jehnham, Farissol, Isaac Nathan, the author of the Hebrew Concordance. In Italy Jewish scholars employed themselves with the translation of Arabic and Latin works. While

France could show only a few notable authors, such as the collectors of the *Tosafot*, Moses de Coney, and Jehiel-ben-Joseph, the poet and exegete Berachja, Germany produced a multitude of writers on the law, such as Eleazar Halevi, Meyer of Rothenburg, Asher Ben Jehiel, Jacob ben Asher, Eleazar ben Jehudali of Worms. Most of the extant Hebrew MSS. belong to this period; but a great part of medieval Jewish literature lies unprinted in Rome, Florence, Parma, Turin, Paris, Oxford, Leyden, Vienna, and Munich.

The *eighth* period (1492-1755) is not marked by much creative or spiritual force among the Jews. In Italy and the East (1492), in Germany and Poland (1550), in Holland (1620), Jewish scholars worked printing-presses, while numerous authors wrote in Hebrew, Latin, Spanish, Portuguese, Italian, and Judæo-German. Some of the most eminent theologians, philosophers, jurists, historians, mathematicians, poets, commentators, lexicographers, grammarians, &c. of this period were, besides Spinoza, Isaac Abravanel, Elias Levita, Seforno, Bertinoro, Karo, Norzi, Rossi, Moses Isserles, Manasseh ben Israel, Lipman Heller, B. Musaphia.

The *ninth* period extends from 1755 to the present time. Encouraged by the spirit of the 18th century, Moses Mendelssohn (q.v.) opened to his co-religionists a new era, which, as in the middle ages, first manifested itself in the national literature. Its character, contents, expression, and even its phraseology, were changed. Poetry, language, philology, criticism, education, history, and literature have been earnestly cultivated. The sacred books have been translated by them into the languages of modern Europe, and foreign works into Hebrew; and many of this once proscribed and detested race have taken an important part in the public and scientific life of Europe. Among the many illustrious names of this last period we can select only a few like Mendelssohn, Maimon, Ben Zeob, Heidenheim, Rapoport, Krochmal, Zunz, Jost, Geiger, Fürst, Sachs, Z. Frankel, Steinschneider, Graetz, Jellinek, Philippsohn, Munk, Salvador, Reggio, S. D. Luzzatto—chiefly cultivators of literature with reference to their own creed and nationality.

To enumerate names of those who were and are illustrious in general literature, in law, philosophy, medicine, philology, mathematics, belles-lettres, &c. we cannot even attempt, since there is not one country in Europe which does not count Jews among the foremost and most brilliant representatives of its intellectual progress. Of Germany—considered to be in the vanguard of European learning—Bunsen said that the greater part of the professors at its universities and academies were Jews or of Jewish origin (Næander, Gans, Benary, Weil, Benfey, Stahl, Dernberg, Valentin, Lazarus, Herz, Steinthal)—certainly a most startling fact. Oppert, Darmesteter, Bernays, Sanders, Karl Marx, Lassalle, Emil Franzos, Crémieux (q.v.), Jessel, Sylvester, Mehlola, Emma Lazarus are likewise eminent names in literature, law, and science; while in finance, statesmanship, and philanthropy the names of Rothschild (q.v.), D'Israeli, Montefiore (q.v.) are universally familiar. Another extraordinary and well authenticated fact is that the European press, no less than European finance, is to a great extent under their control; while, on the other hand, names like Heine, B. Börne, Berthold Auerbach, Henriette Herz, Jules Janin, Felix Mendelssohn-Bartholdy, Halevy, Meyerbeer, Moscheles, Joachim, Ernst, Rubinstein, Wieniawski, Grieg, Brahms, Giuglini, Da Costa, Rachel, Davison, Bendemann, besides hosts of others less familiar to English ears, who shine in all branches of art—music, sculpture, painting,

the drama, &c.—show plainly how unjust is the reproach of their being an 'abstract' people, without sense for the bright side of life and the arts that embellish it. Briefly—they are, by the unanimous verdict of the historians and philosophers of our times, reckoned among the chief promoters of the development of humanity and civilisation. What has been their reward we have seen. Happily the growth of religious toleration, which is the distinctive feature of the present age, has changed all this. In every country to which modern civilisation has penetrated Jews now enjoy, if not the full social recognition which is accorded them in England and France, all ordinary civil and political rights. Russia and Roumania alone, among western peoples, still maintain towards them an attitude of medieval barbarism. But so anomalous a condition of affairs cannot long continue, and the time is surely not far distant when even in these countries they will be accorded a fair measure of the rights of humanity.

For the history of the Jews during the BIBLICAL PERIOD, consult the histories of Ewald, Stanley, Kuenen, Wellhausen, Renan, Herzfeld, Schurer, Stade, Kittel, and works by Edersheim. GENERAL JEWISH HISTORY: Graetz, Jost, Milman, and the smaller works by Palmer, Hosmer, Adams, Morison, Cassel, Magnus. JEWS IN ENGLAND: Picciotto, Margoliouth, Jacobs. Schaible's *Die Juden in England* (1890), and the publications of the Anglo-Jewish Historical Exhibition. HISTORY OF RELIGION: (1) Biblical: Kuenen's *Religion of Israel*, the books on the Prophets by Kuenen, W. R. Smith, and Duhm; on Old Testament theology generally by Oehler, Schultz, and Kiehm; W. R. Smith's *Old Testament in the Jewish Church*, and *Lectures on the Religion of the Semites*; and Baudissin's *Studien zur Semitischen Religionsgeschichte*. (2) General: Jost, *Geschichte des Judenthums u. s. Sekten*; Geiger, *Judenthum u. seine Geschichte*; Weiss's *History of Jewish Tradition* (in Hebrew). (3) Modern: Ritter, *Geschichte der Jüdischen Reformirung*; Friedlander's *Text-book of the Jewish Religion* (1891). JEWISH LITERATURE: Karpeles, Steinschneider, Etheridge, and Stern. ART: Perrot and Chipiez; Madden's *Coins of the Jews*. JEWISH LIFE: 'The Jewish Library,' edited by Joseph Jacobs, the first vol.—by Israel Abrahams, editor of the *Jewish Quarterly*—being *Jewish Life in the Middle Ages* (1897, based on Gudemann and others); *Jewish Ideals*, by Joseph Jacobs (1896); the works of Emil Franzos (*The Jews of Barnow*, &c., trans.); *Children of the Ghetto* (1892), *Dreamers of the Ghetto* (1898); and other works by Zangwill. The movement called 'Zionism,' founded in 1897 for the purpose of securing the settlement of Jews in the Holy Land, has annual congresses; the Dreyfus case in France revealed an unsuspected amount of anti-Semitic bitterness.

See also the articles in this work on

Assyria.	Elonites.	Jerusalem.	Pharisees.
Babylonia.	Egypt.	Jesus.	Sadducees.
Bible.	Herod.	Karaites.	Sammel.
Cabbala.	Hittites.	Maccabees.	Sandhedrin.
Chassidim.	Israh.	Moses.	Synagogue.
David.	Jeremiah.	Pentateuch.	Talmud.

Jew's Ear—*Eridium auricula Judæe*, a fungus, one of the Hymenomyces, which grows on decaying parts of living trees, particularly eldens. Dried Jew's Ear was formerly in repute as an astringent.

Jew's-harp, or JEW'S-TRUMP, a simple musical instrument, which consists of a flat elastic vibrating steel tongue, running between two parallel ribs of metal, and fastened at one end to the farther side of the circle into which the ribs expand; the free end is narrowed to a thin wire and prolonged at right angles to the vibrating piece. The instrument is held between the teeth or lips, kept apart by the rib-frame, and the free projecting end of the vibrating tongue is struck with the finger. The instrument is used from the Highlands of Scotland to Tibet. The first to attain any notable degree of skill as a performer was a soldier of Frederick the Great's army. But his fame was eclipsed by a Wurtenberger named Eulenstein, who played

sixteen Jew's-harps, tuned to different keys; he performed in London in 1828 (died 1890). The derivation of the word seems to be doubtful. It is suggested that 'Jew's' is a corruption of 'jaws' and of 'jeu,' the French word for 'play'; more probably the instrument was called Jew's-harp in derision.

Jew's Mallow. See CORCHORIS.

Jew's Thorn. See JUAUBE and PALURUS.

Jeypore (*Jaipur*), a protected native state in Rajputana (q.v.), with an area of 15,349 sq. m., and a population (1891) of 2,832,276, chiefly Hindus. The only city of importance is the capital. The central part of the state is a sandy tableland from 1400 to 1600 feet above the sea-level; in the east and north-west there are mountains, but in the south-east the soil is rich and fertile. The chief manufactures are enamelled gold-wares, marble sculptures, and fabrics. Large quantities of salt, also, are manufactured at the Sambhar Lake. The gross revenue is about £1,200,000, of which £40,000 a year is paid as tribute to the imperial government. The army numbers about 14,000 men of all arms. Great attention is paid to education. The Rajputana State Railway runs over Jeypore territory for about 150 miles. Jeypore, after many vicissitudes, came under British protection in 1818. The maharajah was eminently loyal during the Mutiny, and was rewarded with an extension of territory.—The capital, JEYPORE, is a walled city, 850 miles NW. of Calcutta and 140 NE. of Ajmere by rail. It is a handsome and regularly-built town, with the maharajah's palace in the centre, and is the most important commercial centre of Rajputana. It was founded as late as 1728. The ancient and now deserted capital, Amber, lies 5 miles to the NE. The commercial business of Jeypore is chiefly banking and exchange, with a capital engaged of over £7,000,000. In addition to the banks there are the maharajah's college, an industrial and economic museum, a school of art, an observatory, a mint, the 'Mayo' Hospital, and numerous temples and mosques, besides the beautiful Rām Nēwas Gardens (70 acres). Pop. (1881) 142,578; (1891) 158,905.

Jezeelites, of the NEW AND LATTER HOUSE OF ISRAEL, a religious sect founded in England by a private soldier, James White (1840-85), who adopted the name of James Jershom Jezeel, and professed to be a messenger from God, whose revelations to him are recorded in 'The Flying Roll.' The headquarters of the sect were at Gillingham, in Kent, where a temple, a college, &c. were partially built. Christ, they believed, by his death redeemed only souls, and those souls who have lived since Moses. For the salvation of the soul belief in the Gospel was sufficient; the body must be saved by belief in the Law. When Christ comes to reign for his millennium He will be greeted by the 144,000 (Rev. vii. 5-8), who will be endowed with immortal bodies; to this chosen band the members of the New and Latter House of Israel aspire to belong. After the death of Queen Esther, Jezeel's widow, in 1888, the sect decayed.

Jhansi, a fortified town in Gwalior state, Central India. During the Mutiny of 1857 the native garrison murdered all the Europeans. In the following April the place was recovered by Sir Hugh Rose. The town, till 1861 in the British North-west Provinces, was in that year made over to Gwalior. Pop. 28,000. Close beside it, in the British district of Jhansi, is the civil station and military cantonment of Jhansi Naubat. Pop. 3000. The *district* of Jhansi begins just outside the native fortress of Jhansi, and is part of the division of Allahabad in the North-west Provinces. Area, 1640 sq. m.; pop. (1891) 409,419.

Jhelum, or JHELAM, also called the Bitasta (whence the ancient Hydaspes), one of the rivers of the Punjab. It rises in the mountains of Cashmere, which country forms its upper basin, and is navigable for about 70 out of 130 miles within that state. On emerging from the Himalayas through the Baramulla Pass, it again becomes navigable for small craft. About 250 miles from its source it enters the plains, and, after a total course of 450 miles, joins the Chenab at Timmu. On the banks of this river was fought the battle between Alexander the Great and Porus. The Jhelum passes by the towns of Srinagar (Kashmir), Jelalpur, Jhelum, and Pind Dadan Khan. The Victoria railway bridge near Meeanee, opened in 1887, is 4875 feet long. See DOAB.—Jhelum (*Jehlum*), town, cantonment, and administrative headquarters of Jhelum district (area, 3995 sq. m.; pop. 609,056), in the Punjab, stands on the Jhelum (Jhelum) River, and is an important entrepôt of trade. Pop. of town, with cantonment, 25,580.

Jib. See SAIL.

Jiddah, or JEDDAH, a seaport of the Hedjaz, Arabia, stands on the Red Sea, about 65 miles W. of Mecca. It is an unhealthy town, suffers greatly from want of water, and is surrounded by a desert. It owes its importance to the fact that it is the port of Mecca, and consequently the place of disembarkation for pilgrims (sometimes 100,000 in a year) bound for the holy city. Besides this it has an active trade, which, however, has steadily decreased, although it still amounts in value to about £1,000,000 annually. The imports comprise corn, sugar, metals, earthenware, manufactured textiles, &c.; and the exports consist chiefly of mother-of-pearl, hides, coffee, balsams, dates, carpets, &c. Pop. (1891) 46,950.

Jig. See GIGA.

Jigger. See CRITGOE.

Jihum. See OXUS.

Jimena, or XIMENA, a town of Spain, 21 miles N. of Gibraltar, has some remarkable caves and the remains of a Moorish castle. Pop. 8500.

Jingo, explained by some as a corruption of St Gingham; by others, of 'Jaanko,' the Basque name for the Supreme Being. Hence the familiar expressions 'by Jingo' and 'by the living Jingo.' By supporters of the Basque etymology the expression is alleged to have originated in Wales, whither Edward I. is said to have had a party of Basque soldiers conveyed during his Welsh wars; but 'Hey Jingo' is first met with in literature in Oldham's *Satyr upon the Jesuits* (1679). Jingoism is now understood to be a sort of British Chauvinism, and in this aspect dates only from the Russo-Turkish war of 1878. At the time there was a strong anti-Russian feeling in London, and the most popular music-hall song of the day was a sort of doggerel threat against Russia, beginning:

We don't want to fight, but by jingo if we do,
We've got the ships, we've got the men, we've got the
money, too.

Jinn. See DEMONOLOGY.

Jitomir. See ZITOMIR.

Joachim, JOSEPH, violinist, was born at Kittsee, near Presburg, on 28th June 1831, and received his musical instruction at Vienna and Leipzig. He first appeared in London in 1841. His performances at Vienna, Pesth, Paris, and London have established for him the position of one of the first violinists of the day. In power and brilliancy of execution, and in the mechanical qualities of playing, he is little if at all inferior to Paganini. His works, which include overtures, Hebrew melodies, and other songs, and compositions for the violin, are pervaded by the same

tenderness and depth of musical feeling that characterise his playing. From 1850 he was appointed concert director in Weimar, and from 1854 in Hanover; and in 1869 he became a member of the senate of the Berlin Academy, and director and professor in the Conservatory of Music. He is a Mus. Doc. of Cambridge and a D.C.L. of Oxford; and on 17th March 1889, his jubilee, was presented with a magnificent violin, and by the German emperor with the Gold Medal for Art.

Joachimsthal, a mining town of Bohemia, at an altitude of 2400 feet, on the southern slopes of the Erzgebirge, 10 miles N. of Carlsbad. In the 16th century the mines yielded large quantities of silver; but the production of this mineral has now dwindled down to less than 250 ewt. a year. Besides silver the mines yield nickel, bismuth, and uranium. There is a royal uranium factory. The people manufacture tobacco, gloves, lace, &c. The first German thalers or dollars (see DOLLAR) were coined here. Pop. 6628.

Joan, POPE, a fabulous personage long said to have filled the papal chair as John VIII. for about three years after the death of Leo IV. in 855. According to the latest and accepted form of the story, she was daughter of an English missionary, and was born at Mainz or Ingelheim. Forming an illicit connection with a monk at Fulda, she put on male attire and fled with him to Athens, where her lover soon died. She then came to Rome, where, from her remarkable learning, she became in quick succession notary to the curia, cardinal, and pope, until her sex was discovered by the premature and public birth of a child during a solemn procession. This startling story was universally believed and appealed to in Italy from 1400 to about 1600; it appears in all the chronicles within this period, and even so late as 1550 is found in the popular guide for strangers known as the *Mirabilia Urbis Romæ*. Felix Hemmerlin, Trithemius, Coecius Sabellius, Raphael of Volterra, Pico di Mirandola, and Adrian of Utrecht (afterwards Pope Adrian IV.) are all unanimous in maintaining it, and indeed Aventine in Germany and Omfrio Panvino in Italy were the first to shake the general belief in its truth. One of the severest blows delivered to the story was given later by the hand of the learned Calvinist David Blondel, in his *Familia: Eclaircissement* (Amst. 1649). So unquestioned was the story that about the beginning of the 15th century the bust of the female pope was placed in the cathedral of Sienna, along with those of the other popes, and there it remained undisturbed till 1600, when, at the request of Clement VIII., Joan was metamorphosed into Pope Zacharias.

Baronius thought it a satire on John VIII.; Aventine, Henmann, and Schrock, a satire on the Pornocracy; the Jesuit Seechi, a calumny originating with the Greeks, just as Pagi and Eekhart thought it did with the Waldenses; Leo Allatius believed it to be based on the story of Thiota, a false prophetess of the 9th century; Leibnitz thought it based on a similar story that might have happened in the case of some foreign bishop; while Blasco and Henke believed it a satirical allegory on the origin and circulation of the false decretals of Isidore—an absurd theory developed still further by Girorer. Mosheim, Luden, and Hase were unable to believe that so definite a story could have arisen without some foundation; Kurtz, while saying that the historical evidence is valueless, regards it as an unsolved riddle. At length Dr Dollinger disproved all preceding theories at once by showing that the myth originated not in the 9th or 10th century, as hitherto

believed, but was first put into writing in the middle of the 13th; and advanced the theory that the story was deliberately originated by the Dominicans and Minorites in the time of Benedict VIII., a deadly foe to the two orders.

The story was long supposed to be mentioned by Marianus Scotus (1028-86), but it does not occur in his most ancient MSS., nor yet in those of Sigebert of Gemblours (1030-1112) or of Otto de Freysingen (died 1158). The first to give it currency is the Dominican Stephen de Bourbon (died 1261), on the authority of the lost or as yet undiscovered MS. of his contemporary, the Dominican Jean de Mailly. Thus the earliest account in writing is discovered to be about the years 1240-50, from which source it was transferred to works of history, like the popular but worthless chronicle of the Dominican Martinus Polonus (died 1278). Yet Pope Joan does not appear in his oldest MSS., and the interpolation must have been made between 1278 and 1312. The main vehicle for circulating the myth in Germany was the chronicle *Flores Temporum*, which, connected with various names, comes down to 1290, and is mainly a compilation from Martinus Polonus. Again, the story was inserted in the so-called *Amatusius*, the most ancient collection known of biographies of the popes, but here again it is a later addition. Soon after we find it in Van Maerlant's *Historical Mirror*, a metrical Dutch chronicle, and in the Dominican Tolomeo of Lucca, and later, in the 14th century, in the Dominicans Bernard Guidonis, Leo of Orvieto, John of Paris, and Jacobo de Acqui, as well as in Ocean the Minorite, the Greek Barlaam, the English Benedictine Raunpht Higden, the Augustinian Amalrich Angerii, Boccaccio, and Petrarch. About the close of the 13th century the story spread with great rapidity, and in the 15th hardly any doubt shows itself at all. John Huss, at the Council of Constance, naturally enough employed the pontificate of Joan as an argument without contradiction from either side; and the Chancellor Gerson, in a speech before Benedict XIII. at Tarascon in 1403, uses the circumstance as a proof that the church could err in matters of fact. The scholastic theologians accepted the fact, and we find so redoubtable a defender of papal despotism as Cardinal Torrecremata maintaining it, so that the gibes of some busy compilers at early Protestant writers for making much of so unsavoury a story are but idle and ill informed. The Dominicans, from their numerous libraries, might easily have exposed the fable, but, as we have seen, they were actively instrumental in its diffusion instead. The story reached the Greeks in the second half of the 15th century, and it is to them we owe the revolting detail that the child was born just as the woman was celebrating High Mass. A Greek scholar, Emmanuel Rhodis, in a clever study (Eng. trans. by C. H. Collette, 1886) finds it impossible to believe that so well authenticated a story could be without historical basis; and indeed the chain of authoritative evidence is exceedingly awkward for those disposed to attach high credit to tradition in matters of belief.

Originally the woman is nameless, and there are many discrepancies about her name (Agnes, Gilberta, Joan), about the date, her place of birth and previous abode, and the mode of the catastrophe. Four circumstances, according to Dr Dollinger, contributed especially to the production and elaboration of the fable: (1) the former use of a pierced seat, popularly supposed to be a precautionary means of verifying the sex of a newly-elected pope, but really a practice symbolic of taking possession, the seats being merely bright red *sedes porphyretice*, from an ancient Roman bath; (2) a stone, with an unintelligible but ingeniously

misread inscription, popularly supposed to be a tombstone of the unhappy Joan; (3) a statue found at the same spot, its long robes being gratuitously taken for the dress of a woman; and (4) the custom of making a circuit in papal processions, whereby a street which was directly in the way was avoided. The woman may have been made of English blood from the odium attaching to England because of the struggle between Innocent III. and King John; and besides, many Englishwomen made the pilgrimage to Rome, while St Boniface, even in his day, complains not only of their number, but their dubious character. Her birth at the German city of Mainz might be due to the inveterate German hostility to Roman claims, together with the fact that Mainz was the leading city of Germany.

See Wensing, *Ober de Pausia Johanna* (Hague, 1845), a destructive answer to another Dutch book maintaining the truth of the story, by Professor Kist (1843; 2d ed. 1866), who thinks Pope Joan was probably the widow of Leo IV.; Bianchi-Giovini, *Esame Critico degli Atti relativi alla Papesa Giuanna* (Milan, 1845); and especially Dollinger, *Die Papstfälsch des Mittelalters* (Munich, 1863; Eng. trans. by A. Plummer, 1871), where the historical evidence is examined and conclusively demolished.

Joannes Damascenus. John Chrysorroas ('the golden-flowing') of Damascus, a great theologian and hymn-writer of the Eastern Church, was born at Damascus, it is said, in 676, but certainly before the end of the 7th century, of a Christian family of distinction in this city, known by the Arabic surname of Mansour. He was carefully educated, together with his adopted brother Cosmas, by the learned Italian monk Cosmas, who had been brought a slave to Damascus, and is said to have been called to the office of vizier to the reigning calif. He replied in quick succession to the iconoclastic measures of Leo the Isaurian with two memorable addresses in which he vigorously defended the practice of image-worship. His biographer John, patriarch of Jerusalem (10th century), tells us that Leo, unable to reach his formidable antagonist by open means, caused a treasonable letter to be forged, in consequence of which John's hand was struck off by order of the calif, but after a night of prayer to the Virgin miraculously restored. It is certain that his later years were spent in a monastery, that of St Sabas near Jerusalem, where we are told he mortified his flesh with ascetic practices of unusual severity. Here he found leisure and inspiration to write his learned works and his religious poetry, was ordained a priest, and died soon after 754.

His chief Greek works are *Fons Scientiarum*, a group of three works, together forming an encyclopaedia of Christian theology; *De Imaginibus Oratorum III.*; *De Recta Sententia Liber*, a formal profession of faith; *Contra Jacobitas*; *Dialogus contra Manichaeos*; *Disputatio Christiani et Saraceni*; *De Draconibus et Strigibus*, in which he combats popular superstitions; *De Dualibus in Christo Vehementibus*, an attack on Monophysite and Monothelite heresy; *Adversus Nestorianos*; *Loci Sancti in Epistolis S. Pauli*, mostly from the homilies of St Chrysostom; *Saepe Parallela*, consisting of passages from Holy Writ illustrated by parallel passages from Scripture and the Fathers; *Homilia*, thirteen in number; *Carmena*, including both canons or prose hymns and metrical hymns; and *Vita Barlaam et Joseph*, his most famous work, now known to be a disguised version of the life of Buddha. Of John's *Canons* the noblest is that for Easter, beginning, in Neale's translation, 'Tis the day of Resurrection; Earth, tell it out abroad.' Other hymns known to Englishmen through the same translator are 'Those eternal bowers,' 'Take the last kiss, the last for ever,' and 'Come ye faithful, raise the strain.' The first adequate edition of the works of Joannes Damascenus was that of the Dominican Michael Le Quien (2 vols. folio, Paris, 1712). This was

reprinted at Venice in 1748, and is the basis of the edition in Migne's *Patrologia* (3 vols. 1864).

See the articles BARLAAM AND JOSAPHAT, and HYMNS; also Dr Neale's *Hymns of the Eastern Church* (1870), and Dr Joseph Langen's admirable book, *Johannus von Damaskus* (Götha, 1879); also the Rev. J. H. Lupton's *St John of Damascus* (1882), in the 'Fathers for English Readers.'

Joan of Arc (Fr. JEANNE D'ARC), the Maid of Orleans, one of the most striking figures that ever crossed the stage of history, was born of poor but devout parents, in the village of Domremy, near Vaucouleurs, on the borders of Lorraine and Champagne, 6th January 1412. Like other maidens of her rank she was taught to sew and spin, not to read and write; and in the quietness of her country-life she grew up tall and handsome in form, sweet and womanly in nature, unlike the other girls around her only in her greater modesty, industry, and devotion. Her religious faith was ardent almost from her cradle; she loved to be alone, and she brooded in her waking dreams over the Bible story and the legends of the saints, until these became as real to her as they were to St Teresa. The cold abstraction of patriotism she never discovered for herself, but she mourned with passionate prayers and tears over the sorrows of down-trodden France, until these prayers took real shapes, and returned to her with form and sound as messages from heaven. And thus there gradually grew up within her heart the conviction that she had been chosen by God to do a special work of deliverance for her country. At thirteen, the noon of a summer's day, she first saw a light and heard an audible voice from heaven, and her terror gradually disappeared as these signs were repeatedly vouchsafed and became dear and familiar to her. St Michael, St Catharine, and St Margaret bent over her and whispered in her ears her heavenly mission, and though calm to outward eyes, henceforward she lived an inward life apart, given to God and her saints. During that unhappy time of national degradation a prophecy, ascribed to Merlin, was current in Lorraine, that the kingdom lost by a woman (Queen Isabella) should be saved by a virgin, and no doubt this, together with her visions, helped to define her mission to the brooding and enthusiastic mind of the young peasant girl. 'I had far rather rest and spin by my mother's side,' she said with simple pathos, 'for this is no work of my choosing, but I must go and do it, for my Lord wills it.' Her story was at first laughed to scorn, but her persistence bore down all opposition, and at last she succeeded in making her way to the Dauphin and convincing him by secret signs of her sincerity. 'There is more in God's book than in yours,' she said to the doubting and hesitating theologians. She put on male dress and a suit of white armour, mounted a black charger, bearing a banner of her own device—white, embroidered with lilies, on one side a picture of God enthroned on clouds, on the other the shield of France, supported by two angels, together with a pennon on which was represented the Annunciation. Her sword was one that she divined would be found buried behind the altar in the church of St Catharine de Fierbois. Thus equipped she put herself at the head of an army of 6000 men, dictated a letter to the English, and advanced to aid Dunois in the relief of Orleans, which was hard beset by the victorious enemy. Her arrival fired the fainting hearts of the French with a new enthusiasm, and rough and hardened soldiers left off their oaths and their debauchery under the spell of her pure presence. On the 29th April 1429 she threw herself into the city, and, after fifteen days of fighting, the English were compelled to raise the siege and retreat, carrying with them the tale of terror

at the strange witchcraft by which they had been overcome. At once the face of the war was changed, the French spirit again awoke, and within a week the enemy were swept from the principal positions on the Loire. Amid the carnage and confusion of her strange surroundings, Joan showed the same purity, simplicity, and good sense that had marked the village girl. She shrank with womanly tears from the sight of bloodshed, and trembled with terror at her first wound, while the brutal taunts of the English soldiers stung her purity to the heart, and drew hot tears of indignation from her eyes. But all thoughts of self were lost in devotion to her mission of which heaven had given such infallible proofs, and now, with resistless enthusiasm, she urged on the weak-hearted Dauphin to his coronation. Less than three months later she stood beside him at Rheims, and with tears of joy saluted him as king. 'Would it were God's pleasure,' she said to the archbishop, 'that I might go and keep sheep once more with my sisters and my brothers; they would be so glad to see me again.' But heaven had reserved for her its highest honour—to set the martyr's crown upon her brow.

Joan could not infuse her spirit into the hesitating coward and his corrupt courtiers, and she wore out her heart with vexation as she saw the work of heaven prevented by the unworthiness of man. She continued to accompany the French armies, and was present in many conflicts, and was mortified to the heart by the failure to carry Paris. At length, on the 24th May 1430, she threw herself with a handful of men into Compiègne, which was then besieged by the forces of Burgundy; and, being driven back by them in a desperate sally, was left behind by her men, taken prisoner, and sold to the English by John of Luxembourg, in November, for 10,000 livres. In December she was carried to Rome, the headquarters of the English, heavily fettered and flung into a gloomy prison, and at length arraigned before the spiritual tribunal of Pierre Cauchon, then Bishop of Beauvais and a wretched creature of the English, as a sorceress and a heretic, while the dastard she had crowned a king left her to die. Her trial was long, and was disgraced by every form of shameful brutality, under hardly even the forms of justice. Day after day a host of learned doctors tortured her simple heart with tortuous questions, the aim of which was to get their victim to condemn herself. Even through the untrustworthy forms in which they are recorded for us her answers show forth the noble simplicity of very truth. Innumerable questions on the nature of her visions were answered with the same calmness and strength, and her judges were for very shame driven to finish the interrogations in private, and to resort to the nameless infamy of sending Nicholas Loyseleur, a pretended confessor, to draw matter for her condemnation from the most sacred confidences of religion. In the judgment she was found guilty of sacrilege, profanation, disobedience to the church, pride, and idolatry, and the formal condemnation was conveyed in twelve articles. The judges did not disallow the possibility of heavenly visions, but they declared those of Joan to be illusions of the devil. They were now ready to send her to her doom, but they wished first to force her to an abjuration in order to degrade her in public opinion, and they tortured her by alternate threats and promises, until the bewildered girl at length declared that she submitted to the church, and blindly subscribed everything they asked of her. They then condemned her to perpetual imprisonment, and forced her again to put on woman's dress. But it was far from being meant that she should escape the fire. As she lay in her cell overwhelmed with self-reproach and despair, and

denied what she most longed for and had been solemnly promised—the eucharist, she was subjected to new indignities from the brutality of her guards, who stripped her of her woman's dress, so that to protect her chastity she was compelled again to put on the forbidden dress she had laid aside. This was at once made the grounds for a charge that she had relapsed, and she was without delay brought again to the stake, May 30, 1431. The woman's tears dried upon her cheeks, and she faced her doom with the triumphant courage of the martyr, declaring that she knew her revelations were from God, and that she had only submitted through fear of the fire. Her confessor to the last held up the cross before her eyes, and in the midst of the flames that wrapped her round she ceased not to repeat the sacred name of Jesus, and to invoke his saints; a last time she was heard to exclaim 'Jesus,' then her head sank down: she had finished her prayer in heaven. So perished the great uncanonised saint of France, leaving an ineffaceable stain upon English honour.

But Joan's mission was accomplished, and by the enthusiasm that she awoke the English were driven from the sacred soil of France. Twenty-five years after her death Pope Calixtus III. acceded to the prayer of her mother and her brothers (who had been ennobled under the name De Lys), that the process by which she was condemned should be re-examined. After a careful inquiry the finding was that the twelve articles on which her sentence was based were false, and that therefore the whole proceedings of the Bishop of Beauvais were null and void. The judgment was publicly declared on the spot, in the market-place of Rouen, on which she suffered. But long before this she had been enshrined a saint in the popular imagination, which read the wrath of heaven into the sudden end that had quickly come to every one connected with the trial. Indeed, the people had been slow to accept the fact that the maid was actually dead, and at first readily believed in the impostor who arose in Lorraine five years later.

The story of Joan has been a rich motive in the world of art, from the honest mediocrity of the youthful Southey and the noble tragic sense of Schiller to the heartless ribaldry of Voltaire and the fantastic mummery of Sarah Bernhardt. Painter and sculptor have spent their genius on the theme without as yet adequately realising its simple grandeur. See Quicherat's elaborate work, *Procès de Condamnation et Réhabilitation de Jeanne d'Arc* (5 vols. 1841-49); the books by Michelet, Henri Martin, and Joseph Fabre; the iconoclastic paradox of Lesigne (1889), H. Wallon's richly-illustrated *Jeanne d'Arc* (4th ed. 1883), Janet Tuckey's sketch (1880), and works by Elaze de Bury (1889), Lançry (1889), Sorel (1889), Marchant (1890), Ayrrolles (1890-94), Lord Ronald Gower (1893), and Mrs Oliphant (1896). For the literary development, see Kummer (1874); and for the military question, Marin's *Jeanne d'Arc Stratégiste* (1889).

Job. The Book of Job is so called from the name of the man whose history is the subject of it. In Hebrew the name is Iyyob, of which no certain explanation has been given. As it now exists, the book consists of five parts: (1) The prologue, chaps. i. ii. This tells us of a man called Job in the land of Uz, who was 'perfect and upright, fearing God, and eschewing evil.' The man's worldly prosperity was in correspondence with his godliness. In the council of heaven the disinterestedness of his religion was called in question by the adversary, who successively receives permission first to deprive him of all his possessions and bereave him of his children, and secondly, to afflict him in his person with a frightful malady. In spite of these afflictions Job holds fast his integrity: 'In all this Job sinned not.' Hearing of his calamities, his three friends among the neighbouring emirs come to condole with him. In

the presence of his friends Job loses his self-possession, and breaks out into a passionate complaint, lamenting that he had ever been born (iii.).

(2) The debate between Job and his friends, chaps. iv.-xxxi. Both the tone and the sentiments of Job's complaint seem wrong to his friends, and this feeling on their part initiates a debate between them and Job upon the meaning of his afflictions, which widens out into a general discussion of the causes and purposes of evil and affliction in God's providence. The theory of the friends is that affliction implies previous commission of sins on the part of the sufferer, though in the case of a good man, such as Job, it is not punitive but disciplinary, meant to wean him from evil still clinging to him; they therefore exhort him to repentance, and hold up a bright future before him. Job denies that his sufferings are due to sin, of which he is innocent; God wrongly holds him guilty and afflicts him. And here the dispute with his friends works into the problem raised by Satan, whether Job would renounce God to his face. Under the insinuations of his friends, which, with his consciousness of innocence, left him no escape but deny the rectitude of God, Job is almost driven to openly disown God. Though stopping short of this, he reaches the conclusion, supported not only by his own history but by much which can be seen in the world, that there is not that necessary connection between sin and suffering which the friends insisted on. The discussion between Job and his friends consists of three circles of speeches: (1) chaps. iv.-xiv.; (2) chaps. xv.-xxi.; (3) chaps. xxii.-xxxi. Each of these circles consists of six speeches, one by each of the friends with a reply from Job. In the last circle, however, the third disputant, Zophar, fails to speak. This is a confession of defeat; and Job, left victor in the strife, resumes his parable, protesting before heaven his innocence, and adjuring God to reveal to him the cause of his afflictions.

(3) The speeches of Elihu, chaps. xxxii.-xxxvii. A youthful bystander, named Elihu, who hitherto had been a silent listener to the debate, here intervenes, expressing his dissatisfaction both with Job and his friends. He is shocked by Job's inverteance in charging God with unrighteousness, and indignant that the friends have not brought forward such arguments as to show him to be in the wrong. His abhorrence of Job's sentiments is even greater than that of the three friends, from whose theories of evil he differs mainly in giving greater prominence to the idea that affliction is disciplinary and proceeds from the goodness of God. (4) The words of the Lord out of the storm, chap. xxxviii.-xlii. 6. In answer to Job's repeated demand that God would appear and solve the riddle of his sufferings the Lord speaks out of the tempest. He does not refer to Job's problem directly, but in a series of splendid pictures from the material creation and animated nature he makes all his glory to pass before Job. The sufferer is humbled and silent. Such thoughts of God bring him back to the right position of man before the Creator—he repents his former words in dust and ashes.

(5) The epilogue, chap. xlii. 7-17. Job having humbled himself before God, and attained to a fuller knowledge of him, is restored to a prosperity double that which he enjoyed before, and dies old and full of days. With the exception of the discourses of Elihu, the connection of which with the poem in its original form is liable to doubt, all these five parts appear original elements of the book, though some of them may contain expansions of a later date.

The traditional view among the Jews was that the Book of Job was strictly historical. Dissentients from this view, however, are referred to in

the Talmud, where a rabbi is alluded to who had said: 'A Job existed not, and was not created; he is a parable.' And Maimonides (died 1204) expressed the opinion that 'Job is a parable, meant to exhibit the views of mankind in regard to Providence.' In the Christian church also the prevailing opinion was that the book contained literal history. Luther, however, while admitting a basis of history, was of opinion that the history had been poetically treated. He says in his *Table-talk*: 'I hold the Book of Job to be real history; but that everything so happened and was so done I do not believe, but think that some ingenious, pious, and learned man composed it as it is.' This is perhaps the prevalent opinion in modern times, though there are many scholars, some of them belonging to the most conservative school of criticism, such as Hengstenberg, who hold that the poem is a pure creation of the author's mind with a didactic purpose and without any historical foundation. That the poem is not strict history is shown by the many ideal elements contained in it—e.g. the heavenly council (chap. i.-ii.; cf. 1 Kings, xvii. 19); the addresses put into the mouth of the Almighty (xxxviii.-xli.); the symbolical numbers, *three* and *seven*, used to describe Job's flocks and his children (i. 2-3); and the profound thought and elaborate imagery in the various speeches, which, so far from being the extemporaneous utterances of three or four persons casually brought together, could only be the leisurely production of a writer of the highest genius. On the other hand, it is not so probable that a work of such extent and written at the comparatively early date to which the book belongs should be purely poetical invention. The reference to Job in Ezekiel (xiv. 14), which can hardly be to our present book, suggests that there was a well-known tradition which represented Job as a man famed for piety in ancient times. This tradition the author of the book laid hold of and no doubt embellished with many details in order to convey through it the lessons in regard to Providence which it was his object to teach.

Students of the book have not found it easy to dispose all its contents under a single conception, and some writers, as Bleek, have contented themselves with stating some lessons which it obviously teaches. The prologue, for instance, shows how even pious men may be visited with severe afflictions, which it is wrong to consider due to special sins on their part, or to regard as signs of God's displeasure. Again, the course of the debate, taken in connection with the divine speeches from the storm-cloud, suggests that it is presumption in man to pass judgment on God's providence, which it is beyond human wisdom to comprehend, man's true wisdom lying in fearing the Lord and reverent submission even amidst intellectual darkness and perplexity. This second truth may be said to be the burden of the words of the Almighty spoken out of the storm-cloud, and many writers have concluded that this truth, taught by God himself, must be just the lesson intended by the book. This view, however, neglects entirely the light given to the reader in the prologue, and also Job's restoration narrated in the epilogue, and indeed the whole debate between Job and his friends. A just theory of the purpose of the book must take account of all its elements. Now, first, the books of Scripture have mostly a practical aim, and are directed to the instruction of Israel as a people in special circumstances. The circumstances disclosed by the book are those of great distress and perplexity in regard to the ways of providence arising out of this distress. Job, though represented as an individual, must be regarded as a type of the suffering righteous, or it may be of Israel. His history, with the lessons it teaches,

are the lessons which Israel should comfort itself with in its circumstances of affliction. Now, these lessons partly come out in the debate with the three friends and partly in the history of Job's mind, his perplexity, return to faith, and restoration. When the great calamity of the downfall of the state befell Israel the prophetic view that it was due to the sin of the people was accepted, and was sufficient when the state as a unity was considered. But many pious individuals suffered for sins of which they had not been guilty, and, as in this age the position and worth of the individual began to rise into prominence, this fact occasioned perplexity in regard to the operation of Providence. Further, when the exile was prolonged and a new generation arose, innocent of the sins of a former age, and yet involved in its punishment, this perplexity increased, and questions began to be asked whether the view that sufferings were always due to previous sin was sufficient. This is the question in debate between Job and his friends. They maintained the affirmative, while Job dissented, founding on his own history and on much that he could perceive in the world. When the author of the book allows Job to put his friends to silence, we may infer that it was his purpose to teach that the ancient view left much unexplained, and was not a solution applicable in all cases. And when in the prologue he exhibits the case of an upright man afflicted as a trial of his uprightness; and in the body of the book the man in spite of much doubt and even sinful frailty holding fast his integrity; and then in the epilogue the same man, victorious in his faith and more reverent in his submission to God, crowned with double prosperity, we may infer that it was his design to teach Israel that sufferings may be a trial of the righteous, which, if reverently borne, will lift them up into fuller knowledge of God, and therefore into more assured peace and felicity. This is the lesson which he desires to teach Israel amidst its sorrows and the perplexities occasioned by them.

Objections have been made to the originality of the prologue and epilogue which have little weight. Among modern scholars the prevailing view is that the speeches of Elihu (xxxvii.-xxxviii.) are an insertion of a later date. This view rests on such facts as these: that Elihu is not mentioned either in the prologue or epilogue; that Job makes no reply to him, nor is he referred to in the divine answer from the storm-cloud; that he betrays a mannerism which looks like the creation of a different author; that the language of his speeches is less pure Hebrew than the rest of the book; and that his strong repugnance to the irreverence of Job, and his more profound sense of man's sin and the goodness of God, belong to a later age than the original book. The section is of great interest and significance in a religious point of view. There are other passages—e.g. chap. xxviii., which it is difficult to fit into the general scope of the book, and a good many passages are wanting in the original form of the Greek version.

The age of the Book of Job must not be confounded with the age of Job himself. Job is assumed to have lived in the Patriarchal period, the colours of which the author has skillfully thrown over his composition. The author, however, is an Israelite, whose work is a reflection of the religious life and religious thought of Israel. Two general facts point to the age of the exile as the period to which the book belongs: first, the condition of great disorder and misery which forms the background of the poem (ix. 24; xii. 6; xxiv. 12, &c.); and secondly, the discussions on Providence and the relation of suffering to the righteous, which reveal a condition of perplexity in men's minds occasioned by the miseries of the captivity. Other

things also point to the same period—e.g. the very highly developed doctrine regarding God, which is paralleled only in Isa. xl. lxxi., and the later psalms (Ps. cxxxix.); and the inwardness of the morality inculcated (e.g. chap. xxxi.); and the general affinity of the book in thought and language with writings of the exile age. Job iii. is probably dependent on Jer. xx. 14 *seq.* The author of the book is altogether unknown. It was only the prophets who usually put their names to their writings.

The literature is very copious, comprising A. Schultens (1737); Umbreit (1832); Hirzel-Olshausen-Dillmann, *Eregt. Handbuch* (1839-69); Stöckel (1842); Schlottmann (1851); Renan (1859); Delitzsch, Ewald (both trans.); Hitzig (1874); Cox (1880); Davidson (Cambridge Bible for schools, 1884); Eradley (1887); Froude, *Short Studies* (vol. i.); Budde, *Beiträge zur Kritik d. B. Hiob* (1876); Grill, *Zur Kritik d. B. Hiob* (1890).

Job's Tears (*Coix lachryma*), a corn-plant of India. It is a grass, sometimes rising to the height of eight feet, with the stout habit of maize, to which also it is botanically allied. The name is derived from the tear-like form of the hard, shining, bluish-white seeds, which are sometimes made into bracelets and necklaces, and are also an article of food. Though one of the worst of the cereals, it has become almost naturalised in Spain and Portugal.

Jocelin de Brakelonde, a Benedictine monk at Bury St Edmunds, who held successively the offices of abbot's chaplain and almoner, wrote a domestic chronicle of his abbey from 1173 to the year 1202, and died about 1211. This is the famous *Chronica Jocelini de Brakelonda*, edited by J. G. Rokewode for the Camden Society in 1840, which gave Carlyle the inspiration out of which grew *Past and Present*, one of the happiest of his works. The admiration of this simple and veracious 13th-century monk for his superior, Abbot Sampson, touched the sympathetic imagination of the great 19th-century champion of hero-worship, with whose masterpiece Jocelin's name will remain for ever inalienably linked.

Jockey Club. See HORSE-RACING.

Jodeln, a peculiar manner of singing with the falsetto voice in harmonic progressions, practised by the Tyrolese and the Swiss.

Jodhpur, or MARWAR, the largest in area of the Rajputana states, containing 37,000 sq. m.; and the second in population (2,521,727 in 1891). Agriculture generally is in a backward condition, and there are few manufactures save of salt from the Sambhar lake, half in Jodhpur and half in Jeypore (q.v.). There are no railways, but one good road traverses the state. Education is neglected. The climate is remarkably dry, and the difference of temperature between night and day very great. Jodhpur was taken under British protection in 1818, paying a tribute of £10,000 a year, and providing a 'contingent' of native horse. The country was ill governed; and the contingent joined the mutineers in 1857.—The capital city of the state, Jodhpur, founded in 1459, is of little interest. The marked difference between Jodhpur and the adjacent state of Jeypore (q.v.) is very interesting.

Joel, the second in order of the twelve minor prophets. He is designated in i. 1 as the son of Pethuel, or (as it is given in most of the ancient versions) Bethuel, but of his personal history nothing is told. It can be inferred, however, from his book, with a high degree of probability amounting almost to certainty, that he lived in or near Jerusalem considerably after the exile. The Book of Joel falls into two distinct parts, the separateness of which is obscured for readers of the Authorised

English Version by the use of futures instead of preterites in ii. 18, 19*o*; the passage is correctly given in narrative form in the Revised Version. The first part, addressed by the prophet in his own name to his contemporaries, relates to a present plague of locusts and the calamities caused by it; i. 2—ii. 11 describes with vivid hyperbolic imagery the dire invasion which threatens the destruction of the country and the arrival of the final consuming judgment known as 'the day of Jehovah'; in ii. 12-17, speaking in the name of Jehovah, he summons the people to a solemn fast at the sanctuary and the priests to intercessory prayer. The second part contains Jehovah's answer, prefaced by the words already referred to: 'Then was the Lord jealous for his land, and had pity on his people; and the Lord answered and said unto his people.' First, a promise of fruitful seasons to make up for the ravages of the locusts is given (ii. 19-26); this is followed by the promise of the outpouring of the Spirit on all the Jews and even upon their servants, and the final coming of the day of the Lord, which is to issue in a divine judgment upon their heathen enemies in the valley of Jehoshaphat ('Jehovah judgeth') and in the final establishment of Jerusalem as a holy city, the centre of fertility to the surrounding land (ii. 27—iii. 21). The style of Joel is regarded by scholars as elegant and pure rather than original; his prophetic conceptions are largely modelled on those of older prophets from Amos to Ezekiel. Until recently, indeed, the prevailing inclination of critics was to assign an early date to the book, most of them placing it in the minority of Joash, king of Judah, because the priests, and not a king, appear as heads of the commonwealth. But this goes better with the post-exilic date, to which other features in the prophecy clearly point. The dispersion of Israel is alluded to in iii. 1, 2; Judah and the people of Jehovah are regarded as synonymous; and the reference to the slave-trade with the Grecians is inconsistent with an early date. Ancient and medieval interpreters commonly took the locusts in Joel's prophecy figuratively or allegorically, and the same view has been argued for, though by no means convincingly, by some recent scholars. There are separate commentaries on the Book of Joel by Credner (1831), Wünsche (1872), and Merx (1879). See also the commentaries on the minor prophets mentioned under HOSEA.

Joe Miller's Jests. See JEST-BOOKS.

Johanna, one of the islands of the Comoro (q.v.) group.

Johannesburg, the chief town and mining centre of the Transvaal goldfields, is situated about 6000 feet above sea-level, 298 miles N.E. of Kimberley, and 350 miles N. of Ladysmith. Railway connection, completed in 1892, brought Johannesburg within 60 hours' journey of Capetown; and it is now connected also with Port Elizabeth (714 miles), Durban (437 miles), and Lourenço Marquez on Delagoa Bay (396 miles). In 1886 the Transvaal government proclaimed certain farms on the famous Reef of Witwatersrandt as public goldfields; and the ground on which Johannesburg now stands was selected as the site of the new station or town. From the time of the foundation (1887) the town and the mining industry grew rapidly. In 1895-96 it became the scene of the struggles of the Uitlanders to extort political and other rights from the Boer government (interrupted by the Jameson (q.v.) raid of January 1896), which eventually resulted in the war of 1899-1900, and the annexation of the Transvaal and Orange Free State as British colonies. A dreadful dynamite explosion wrecked part of the town in 1896. As yet in 1899 (with pop. of 60,000) the

streets were not lighted, and only the concession for paving the principal street had been granted. The government buildings consist of the post and telegraph offices, and the mining-commissioner's and the landrost's (magistrate's) offices, &c. Fine banks, churches, hotels, club-houses, with shops and private houses, and a magnificent stock exchange have been erected. The climate is, or would be very healthy, were not the sanitary conditions so unsatisfactory, and were it not for the frequent terrible dust-storms, in consequence of which fevers and pneumonia are often prevalent. The neighbourhood of Johannesburg is delightful, and villas and fine suburban houses are springing up. The population at the census of July 1896 was 102,714, of whom 51,225 were whites.

See TRANSVAAL; Thomas, *Johannesburg in Arms* (1896); Mann, *The Truth from Johannesburg* (1897).

Johannisberg, a village of Prussia, overlooking the Rhine, 13 miles W.S.W. of Wiesbaden. It has a hydropathic, and manufactories of pianos and printing-presses, but is noteworthy chiefly for its castle (1722-32), the property of the Metternich family, and the famous vineyards (38 acres) on the castle hill, producing the choice *Johannisberger* white wine. Pop. 1316.

John, the Apostle, son of Zebedee and younger brother of James, was a Galilean fisherman, probably a native of Bethsaida. From Matt. xxvii. 56, compared with Mark, xv. 40, it is probable that his mother was Salome, whom some infer from John, xix. 25, to have been the sister of the mother of Jesus. In the synoptic gospels James and John, like Peter and Andrew, receive their call to the discipleship while engaged in their daily occupation by the sea of Galilee, and the surname 'Sons of Thunder' is conferred on them by the Master. Henceforward John is always mentioned as one of 'the twelve,' and generally figures also as a member of an inner circle of disciples, of which only his brother James and Peter are members besides himself. In the fourth gospel John is not mentioned by name, but ancient as well as modern expositors identify him with the companion of Andrew, who first became acquainted with Jesus at Bethany, beyond Jordan, while he attended John the Baptist as a disciple, and forthwith attached himself to him, Andrew and Peter becoming disciples of Jesus at the same time. John is further identified with the 'other disciple' who in John xiii. 23, xxi. 7, 20 is distinguished as the disciple 'whom Jesus loved.' This expression is usually taken to imply an exceptional sweetness and loveliness of character in John; but what we read in the Synoptists shows that, originally at least, he must have been somewhat passionate, narrow, and ambitious. After the ascension of Jesus John seems to have remained in Jerusalem, where he still was when Paul visited that city for the second time after his conversion (Gal. ii. 9). He does not appear to have been there at the time of the last visit of the apostle of the Gentiles, about 58 A.D., and his subsequent history is involved in the greatest obscurity. A chronicler of the 9th century, Georgios Hamartolos, claims to have read in the now no longer extant works of Papias that John was slain by the Jews like his brother James; and that he died a violent death is apparently implied also in a passage from Heraclon preserved by Clement of Alexandria. But general ecclesiastical tradition from the time of Justin (about 150 A.D.) has identified him with the author of the Apocalypse (see REVELATION), and from that of Irenaeus (c. 175 A.D.) has represented him as spending the closing years of his ministry at Ephesus, and dying there at an advanced age, after having written not only the Apocalypse but also the Gospel and the three

Epistles which bear his name. The authenticity of this tradition as to his having ever lived in Ephesus has been challenged by many critics, who hold that it rests on a confusion made by Irenaeus between John the apostle and a certain John 'the elder' or 'presbyter,' 'a disciple of the Lord,' mentioned by Papias as distinct from the apostle. For the negative view they also urge the silence of the New Testament (Acts, Eph., Pastoral Epp., 1 Pet.), of the Apostolic Fathers, of Justin, and of Hegeppins, and others. For the literature of the question, see the works mentioned below, under JOHN (GOSPEL ACCORDING TO).

John, EPISTLES OF. Of the three canonical epistles ascribed to the apostle John, the first is not in form an epistle, but a warm practical hortatory treatise based on the theological principles of the fourth gospel, with warnings against Docetic and Antinomian gnosis. The second and third are short letters of an occasional character, addressed to individuals—unless indeed the 'elect lady' of 2 John be a figurative title for a church, a view which has great probability and has found very large acceptance among modern interpreters. The first express mention of epistles as written by John the Apostle is in the Muratorian Canon (about 170 A.D.), which quotes 1 John i. 1, and elsewhere enumerates two under his name. From the time of Origen 2 John and 3 John were classed among the books of the canon whose authenticity was disputed; Eusebius and Jerome attributed them to John 'the Presbyter,' as distinguished from John the Apostle, and this view has been followed by many modern writers, beginning with Erasmus. On the internal evidence critics are for the most part agreed that 1 John has the same author as the fourth gospel, or is at least by a writer of the same school. The epistle has occasionally been attributed to the apostle by critics who denied his authorship of the gospel. As to the priority of the two works in point of date, opinion is almost equally divided. For commentaries, see the expositions of the whole Johannine writings by Lücke, Baumgarten-Crusius, and Ewald; also the special works by Ruther (in Meyer's *Commentar*, 4th ed. 1880; Eng. trans.), Braune (in Lange's *Bibelwerk*, 3d ed. 1885; Eng. trans.), Plummer (2d ed. 1886), and Westcott (2d ed. 1886).

John, GOSPEL ACCORDING TO. The fourth canonical gospel, which express tradition since about 170-80 A.D. (Theophilus of Antioch, Irenaeus of Lyons, Muratorian Canon) has unanimously ascribed to the apostle John (identifying the 'disciple' of John xxi. 24 with the son of Zebedee), is distinguished by a number of strongly-marked characteristics from the first three, usually known as the synoptical (see GOSPELS). The keynote of what Clement of Alexandria has called 'the spiritual gospel' is struck in the prologue (i. 1-8), where the place of the genealogies and detailed accounts of the circumstances of the birth of Jesus in the synoptics is taken by a profoundly metaphysical statement of the doctrine of the incarnation of the Eternal Logos. The scene of the narrative of the earthly life of Jesus which follows this prologue is laid from first to last almost entirely in Judea, while in Matthew, Mark, and Luke it is confined with nearly equal exclusiveness to Galilee. While, again, the synoptics, so far as they suggest any chronology at all, seem to imply that the public ministry of Jesus did not extend much over a year (coinciding in this with the mass of early tradition), the fourth gospel mentions at least three passovers, and possibly more. There are, besides, important differences in various minor chronological details. Thus, the cleansing of the temple, which the synoptics place at the end of

the ministry, is in the fourth assigned to the beginning: the last supper is dated on the evening before the passover, and not on the passover itself; and the anointing at Bethany is stated to have taken place six days, not two, before the passover. Again, there is a most striking difference in the selection of material. The fourth gospel, passing over much that is common to the other three—the temptation in the wilderness, the transfiguration in Galilee, the agony in the garden, the sermon on the mount, and most of the parables and other discourses—introduces us to new persons (Nathanael, Nicodemus, and others), new localities (such as Cana, Enon, Sychar, Ephraim, and Bethany beyond Jordan), and new scenes and situations. Its miracles, which are comparatively few, and include no case of the casting out of devils, are not for the most part even alluded to by the others (that of the raising of Lazarus is a conspicuous instance in point); and it has been remarked that they are presented less as deeds of compassion wrought at the pressing call of human need than as spontaneous displays of supernatural power primarily designed to prove a divine mission. The greater part of the work is composed of relatively long discourses, in their argumentative and theological character on the whole very unlike the aphorisms, parables, and practical or prophetic exhortations attributed to Jesus in the synoptics, while they are all very similar to one another in general type, and their style is indistinguishable from that used by the author himself when writing in his own name. The aspects in which, through these discourses and otherwise, Christ, the incarnate Logos, is presented in the fourth gospel, are widely distinct from those in which Jesus of Nazareth comes before us in the others. The element of human development is wanting, and his own consciousness of a Divine nature and mission, as well as the recognition of these by his followers, are represented as having been operative from the first. Finally, it sets forth a more inward and spiritual type of theology and religious experience, and there is for the most part in its eschatology and doctrine of the life eternal a conspicuous absence of those images and conceptions—everywhere present in the synoptics—derived from the Jewish circle of ideas relating to the kingdom of the Messiah and the doctrine of the last things.

It is less than a century since these and similar features—such as its more elaborate character as a piece of literary composition—began to be discussed in their bearing on the question of the origin and historical character of the fourth gospel. The question was first started by the English deists (see Evanson, *The Dissimilarity of the Four generally received Gospels*, 1792), but was not handled with any approach to the fullness and thoroughness which the importance of the subject demanded until taken up by Bretschneider, whose learned and acute *Probabilia de Evangelii et Epistolarum Joannis apostoli indole et origine* (1820) may still be read with profit. Bretschneider in 1821 professed himself satisfied with the numerous replies elicited by the arguments he had based on the differences between the Johannine and the synoptic traditions, the weakness of the external evidence for the Johannine authorship of the fourth gospel, and the inherent improbability of such a work having been written by the son of Zebedee. In the course of the next twenty years the authenticity was powerfully defended by the speculative insight and rare religious genius of Schleiermacher; but De Wette (1826: 37) found himself unable to ignore the element of developed Hellenism in the discourses, and, while not denying the partial authorship of John, inclined to assign the work as a whole to a disciple. A somewhat similar

view was taken by Credner (1836), and also by Reuss (1840), the former of whom laid emphasis on the 'subjective' character of the gospel, and held that it was to be regarded less as a history than as a doctrinal exposition, in which the discourses of Christ are mixed up with the Logos speculations into which the author has been led by his studies in Greek philosophy. The discussion of the question reached a wholly new stage in the writings of Baur (chiefly between 1844 and 1847) and his followers of the so-called 'Tübingen' or 'Tendency' school—a school the value of whose labours in quickening a true historical sense for New Testament subjects can hardly be overestimated, and whose influence (not yet exhausted) has been powerfully and beneficially felt far beyond the circle of its immediate disciples. Space will not allow a full statement of the position taken by Baur or of the arguments he advanced in its support. They can be adequately appreciated only in connection with his theory of the development of early Christianity as a whole. This he represents as having passed through three stages—first of acute antagonism between Ebionitism and Paulinism (down to about 70 A.D.), and next of abatement of claims on both sides (down to about 140 A.D.), while finally, after the elimination of Ebionitic and Gnostic extremes, came the reconciliation of the two parties—practically in the ascendancy of Catholicism as exhibited in the Roman Church with Peter and Paul as its two recognised founders, and ideally and theoretically in the fourth gospel (see BAUR; also BIBLE, Vol. II, p. 123). Briefly and generally stated, his view of the fourth gospel is that it was produced about 160–70 A.D. by a Gentile Christian, who, firmly and heartily convinced that the historical Jesus was the incarnate Logos and very Son of God, sought to exhibit this truth to his contemporaries with concrete vividness in a persuasive literary form by means of a quasi-historical narrative embodying the ideas and principles which he regarded as essential, for which end he made free and arbitrary use of such elements of the current (but still somewhat fluctuating) tradition as were capable of being adapted to his purpose. Subsequent discussion has led the modern representatives of the Tübingen school to modify several of these positions as originally taken by Baur. Thus, as regards date, it was urged by the other side that the existence of the fourth gospel was demonstrated for at least 130–40 A.D. by the frequent quotations from it in the writings of Justin Martyr; and it is now generally admitted that the passages referred to prove at least the wide currency at that comparatively early period of many of the special ideas of this gospel. This and other considerations have led such writers as Pfleiderer and Keim respectively to carry it back to 140 A.D. and 130 A.D.; and, indeed, Renan has formulated the canon that the earlier we can place it the less inexplicable it becomes. This canon is suggested by the difficulty of accounting for the introduction of a gospel in many respects so new after the synoptics had once had time thoroughly to establish themselves, and they undoubtedly were established in the recognition of the church by the time of Justin. The opponents of the Tübingen school, on the other hand, such as Weiss, set up an opposite canon: the later the date the easier to explain the allusions to Gnosticism and the comparatively tardy manner in which the work made itself felt in the official theology of the 2d century. Another point in which Baur's disciples no longer hold with him has reference to the authorship, which he assigned to a Gentile Christian. In the course of the keen controversy which Baur's writings elicited, much stress has been laid on the evidence supplied by the

gospel itself to the effect that its writer was a Jew, acquainted not only with the LXX, but with the original Hebrew of the Old Testament, familiar with Jewish customs and habits of thought, with the topography and local peculiarities of Jerusalem and the temple, and of Palestine generally. This is now very generally conceded; but it is added that his sympathetic familiarity with the writings of Philo suggests rather an Alexandrian than a Palestinian Jew, while his acquaintance with the Holy Land (which after all cannot be shown to have been exhaustive) may have been acquired in the course of travel. But as regards many of the vivid literary touches on the part of the narrator, which on one theory are held to show consummate descriptive or dramatic skill, and on the other to betoken the eye-witness, it is pointed out that such touches are not wholly absent even from some gospels that are confessedly apocryphal, and, further, that it is not always impossible for one who has only heard the account of an eye-witness to convey in writing some graphic idea of what he has heard. If Baur's view has been in some important respects modified by his successors, concessions have also been made on the 'apologetic' side to such an extent as suggests the possibility of an ultimate agreement between the two parties in the controversy. Thus B. Weiss, in the paragraph of his *Introduction* (1889) devoted to the 'limits of the historicity' of John's gospel, points out that, writing as he did at such a distance of time from the incidents he had witnessed and the discourses he had heard, it is in the nature of the case unreasonable to expect that at least the longer discourses should be reproduced word for word. John's manner of reproducing the words of Jesus is, in fact, characterised by great freedom, his purpose being not merely to reproduce them but at the same time to explain them and bring out their inner meaning. With this view not merely the actual phraseology but also the historical setting has been frequently modified, the evangelist caring only for the eternal significance of what he had to tell. Precisely because he was an apostle could he do this without embarrassment or hesitation. What applies to his reproduction of the speeches applies also to the narrative portion of his work, where he often sacrifices the actual connection, and modifies the historical colour of events in the interests of his one primary object. The failure of memory in an old man must also be taken into account. The view thus boldly taken by Weiss is substantially also that of Beyschlag and others who cannot shut their eyes to the obvious marks of growth and development which are seen when the ideas of the fourth gospel are compared with those set forth in the synoptical tradition, and who recognise that the author of the former, whoever he was, must, whether consciously or unconsciously, to some extent have been carrying back into a previous generation the matured thoughts of his own time. It remains to add that the external testimony to the authorship of the son of Zebedee is extremely weak; his name is not associated with the gospel until the last quarter of the 2d century, and the story of the manner in which, 'exhorted by his fellow-disciples and bishops, he wrote down everything in his own name' while 'all should certify it,' as given in the Muratorian Canon, is obviously legendary (compare JOHN).

For the literature of the subject, see the *New Testament Introductions* of Hilgenfeld (1875), Bleek (4th ed. by Mangold, 1886), Holtzmann (2d ed. 1886), and Weiss (2d ed. 1889; Eng. trans. 1887), and also Sanday's *Authorship and Historical Character of the Fourth Gospel* (1872). Dr Sanday conveniently arranges modern writers on the subject into four classes: (1) Those who maintain the Johannine authorship and complete authenticity of the

gospel, such as Alford, Ellicott, Westcott, Caspari, Wieseler, and (with some qualification) Luthardt; to this list ought to be added the names of Salmon, Lightfoot, Ezra Abbot, and indeed of almost all English or Catholic churchmen who have written on the subject. (2) Writers who maintain Johannine or mediate Johannine authorship and qualified authenticity in the first degree, the names here mentioned being those of Lücke ('whose work is still one of the undisputed classics of biblical criticism'), Bleek, Ewald (with some qualification), Meyer, and Orr, to which add the names of Beyschlag, Ritschl, B. Weiss, and of Dr Sanday himself ('To me it is far more probable that [the discourses] represent only the natural, spontaneous, unconscious development that the original elements of fact have undergone in the apostle's mind. It cannot, I think, be denied that [they] are to a certain extent unauthentic, but this is rather in form and disposition than in matter and substance'). (3) Writers maintaining mediate or immediate Johannine authorship and qualified authenticity in the second degree, such as Renan (*Vie de Jésus*, 13th ed. 1867), Weizsäcker and Wittichen, to which names add those of Reuss and Hase. (4) Writers who deny the Johannine authorship and authenticity entirely—Hilgenfeld, Keim, Scholten, Sir R. Hanson, J. J. Tayler; to this class belong also Meijboom, Hoekstra and Louan (Dutch), Havet, A. Réville, J. Réville (French), and of English writers, S. Davidson, the author of *Supernatural Religion*, and E. A. Abbott, whose able article 'Gospels' in the *Encyclopædia Britannica* contains an interesting view of the Philonic elements in the gospel. There are valuable expository works on the Johannine writings by Locke (1820), Ewald (1861-62), and Reuss (1879); see also the commentaries on the fourth gospel by Meyer (new ed. Meyer-Weiss, 1880; Eng. trans.), Godet (1864-65; Eng. trans. 1877), Keil (1881), Westcott (1882), Plummer (1882), Sadler (1883) and Milligan (1883).

John, the name of a long line of popes, the number of whom is variously stated by different historians. John VIII. (872-82) is styled the IX. by some writers, who, accepting the story of Pope Joan (q.v.), reckon her as John VIII.; and John XV. (985-96) is also called XVI. by those who place before him another John who died within a few days of his election. Without entering into this question, it will suffice to say that the last of the line of popes called John is John XXIII., who filled the papal chair most unworthily in 1410-15. The following popes of this name appear to deserve some special notice.—JOHN XII. was the son of Alberico, and grandson of the notorious Marozia, who, during the pontificate of John X. (913-27), ruled with almost supreme power at Rome. John was originally named Octavianus, and, being elected pope in 956 through the violence of the dominant party when only in his nineteenth year, was the first in the papal line to originate the since familiar practice of changing his name. The Emperor Otto in 963 in a synod of the clergy, overstepping all the ordinary rules of canonical procedure and legal precedent, caused sentence of deposition for scandalous life to be pronounced against John, and Leo VIII. to be elected in his stead. John, however, re-entered Rome in the following year with a strong party and drove out Leo; but his career was cut short by a dishonourable death.—JOHN XXII. is one of the most celebrated of the popes of Avignon. He was born at Cahors in 1244, and was elected pope in 1316, on the death of Clement V. Attempting to carry out in very altered circumstances the vast and comprehensive policy of Gregory VII. and Innocent III., John interposed his authority in the contest for the imperial crown between Louis of Bavaria and Frederick of Austria, by not only espousing the cause of the latter but even excommunicating his rival. The diet of Frankfort refused to obey, and a long contest ensued, not only in Germany but also in Italy, where the Guelph or papal party was represented by Robert, king of Naples, Frederick of Sicily being the chief leader of the Ghibel-

lines. The latter was placed by John under the same ban which had already been proclaimed against Louis; but in 1327 Louis came to Italy in person, and having been crowned at Milan with the iron crown, advanced upon Rome, expelled the papal legate, and was crowned emperor in the church of St Peter's by two Lombard bishops. Immediately on his coronation he proceeded to hold an assembly, in which he caused the pope, under his original name of James de Cahors, to be thrice summoned to answer a charge of heresy and breach of fealty; after which he caused him to be deposed, and Peter de Corvara, a monk, to be elected pope, under the name of Nicholas V. These measures, however, were attended with little result. Louis returned to Germany, and the Guelphic predominance at Rome was restored, the papal representative resuming his authority. But John XXII. never personally visited Rome, having died at Avignon in 1334, when, although without incurring the suspicion of personal aggrandisement, he had accumulated in the papal treasury the enormous sum of 18,000,000 florins of gold.

John, king of England, the youngest of the five sons of Henry II. and Queen Eleanor, was born at Oxford, 24th December 1167. At his birth his father, who had provided for his elder brothers, called him John Lackland, and the name stuck to him. But the boy was Henry's darling, and he betrothed him to his wealthy cousin, Hawisa of Gloucester, made the new feudal tenants of Ireland do homage to John as well as himself in 1177, and sent him to Ireland as governor in 1185. Although John's misconduct and wanton insolence soon compelled his recall, Henry obtained the pope's consent to his being crowned king of Ireland; but the coronation never took place, and in 1189 the announcement that John was among his enemies gave the king his death-blow. Richard on his accession bestowed four English shires and other lands on John, and married him to Hawisa. No sense of gratitude, however, held John from endeavouring to seize the crown during Richard's captivity in Austria; but he was pardoned and treated with great clemency, and was nominated his successor by his brother on his deathbed. In the 12th century the principle of primogeniture was but imperfectly adopted, and although Arthur, the twelve-year-old son of John's elder brother Geoffrey, appears to modern eyes beyond question the rightful heir to the throne, the general opinion of his own day was in favour of John, who had the nomination of the late king. Moreover, at his coronation at Westminster, which took place on 27th May 1199, the old English doctrine of election to the crown was for the last time formally asserted, nor did any man dissent. On the Continent, however, the barons of Anjou, Maine, and Touraine acknowledged Arthur, whose claims were supported by Philip of France. But Aquitaine was secured to John by the energy of his mother Eleanor, and in May 1200 he succeeded in buying off Philip, married his niece Blanche to Philip's son Louis, and received Arthur's homage for Brittany. But in the same year he persuaded his Aquitanian and Norman bishops to annul his marriage with his cousin, and married Isabel, the child-heiress of Angoulême; by which action he offended both the house of Gloucester and the powerful family of La Marche, one of whom was betrothed to the heiress. In the war that ensued, Arthur, while endeavouring to capture his grandmother Eleanor, at the castle of Mirabeau, was surprised by John and taken prisoner. Before Easter 1203 he was dead; murdered by John's orders, if not by the king's own hand, men said. This crime cost John his continental dominions. Philip at once marched against

him, captured city after city, and finally, in March 1204, after a seven months' siege, took King Richard's 'sunny castle,' the Château-Gaillard itself, John making scarcely an effort against him. Only a portion of Aquitaine was left to the English king, nor could he recover more by the short campaigns he made in Poitou in 1206 and 1214.

The first period of John's reign thus ends with the separation of Normandy (1204), which compelled those who held lands in both countries to make choice of one; henceforward the barons of England are English. Immediately after, in 1205, John entered on his quarrel with the church, the occasion being a disputed election to the archbishopric of Canterbury. The matter was referred to the pope, Innocent III., and in 1207 he had Stephen Langton, an English cardinal at Rome, a man of great learning and piety, elected, and consecrated him when John had furiously declined to receive him. In 1208 the kingdom was placed under the Interdict (q.v.). John retaliated by confiscating the property of the clergy who obeyed the interdict, and driving the bishops into exile. Otherwise, too, he acted vigorously. He compelled William, king of Scotland, who had joined his enemies, to do him homage (1209), put down a rebellion in Ireland (1210), and subdued Llewellyn, the independent prince of Wales (1212). Meanwhile John had been solemnly excommunicated (1209), and now, in 1212, the pope issued a bull deposing him from his kingdom, and absolved his subjects from their allegiance; a crusade was proclaimed, and to Philip was intrusted the execution of the sentence. John, outlawed by the church, and hated for his cruelty and tyranny by his subjects, found his position untenable, and was compelled to make abject submission to Rome. On 15th May 1213 he resigned his crown to the pope's envoy at Dover, and agreed to hold the kingdoms of England and Ireland henceforth as fiefs of the papacy, and to pay a thousand marks yearly as tribute. This shameful submission closes the second part of John's reign. For Innocent the degrading exaction was a false step. From this period may be dated the hostility to the papacy which culminated in the Reformation.

Philip, wrathful and disappointed, turned his forces against Flanders; but an English fleet surprised the French fleet at anchor and with only the sailors on board, and captured 300 vessels and burned 100 more. This put an end to all talk of invasion, and in 1214 John made a campaign in Poitou. Most of the barons, however, refused to serve abroad, and, Philip having crushed the emperor and his allies at Bouvines (27th July), John returned to enter on the struggle with his subjects which occupied all the remainder of his reign; and now for the first time in English history we see the barons, clergy, and people ranged side by side against the tyranny of the king. A demand that John should keep his oath and restore the laws of Henry I. was scornfully rejected. John relied mainly upon the support of the pope, but he also took the white cross, and endeavoured to detach the clergy with the heavy bribe of free election to bishoprics—but vainly, to their honour be it said. Preparations for war began on both sides. About Easter 'the army of God and Holy Church,' under four great eals and forty barons, assembled at Stamford and marched to London; they met the king at Runnymede, and on the 15th June 1215 was signed the Great Charter (Magna Charta), the basis of the English constitution. In August the pope annulled the charter, and the war broke out again. John had a share of the military talent of his family, and the first successes were all on his side, until the barons called over

the dauphin of France to be their leader. Louis landed in May 1216, and John's fortunes became desperate. Yet the English leaders had already begun to distrust their foreign allies, and a number were even preparing to renew their allegiance, when death overtook the king at Newark, on 19th October 1216, in the forty-ninth year of his age.

For John's character, see the excellent accounts of his reign in Pearson's *History of England* (vol. ii. 1867), Green's *Shorter History*, and Stubbs's preface to *Walter of Coventry* (vol. ii. 1873). See also Stubbs's *Constitutional History* (vol. i.), and *The Early Plantagenets* in 'Epochs of Modern History'; Pauli, *Geschichte von England* (vol. iii. 1858); and, down to the loss of Normandy, Norgate, *England under the Angevin Kings* (vol. ii. 1887).

John II., king of France, surnamed the Good, the son of Philip VI., was born in 1319, and succeeded his father in 1350. In 1356 he was taken prisoner by Edward the Black Prince at Poitiers and carried to England. After the treaty of Bretigny (1360) he returned home, leaving his second son, the Duke of Anjou, as hostage, till he should fulfil the terms of his ransom. But in the meantime the duke escaped back to France. John, however, chivalrously kept his word, and returned to London early in 1364; but he died on 8th April in that same year, without having regained his freedom. His eldest son, Charles V., succeeded him.

John, the blind king of Bohemia, the son of Count Henry III. of Luxemburg (afterwards the Emperor Henry VII.), was born on 10th August 1296, and, having married (1310) the heiress of Bohemia, was crowned king of that country in 1311. In the struggle between the rival houses of Austria and Bavaria for the imperial crown he gained the victory for the latter at Mühldorf in 1322. In 1333-35 he was warring in Italy on behalf of the Guelphic party. In 1334 he married Beatrix of the French Bourbon house, and thenceforward was an active ally of the French king; he went to his assistance against the English in 1346, and fell at Crécy (26th August). He had been blind since 1340. During his reign Silesia was acquired from Poland.

John Dory. See DORY.

John of Austria was a natural son of the Emperor Charles V. and Barbara Blomberg of Ratisbon, and was born 24th February 1547. He was early brought to Spain, and after the death of his father was acknowledged by his half-brother Philip II. Honours and an annual allowance were bestowed upon him, and he was educated along with the Prince of Parma and the Infant Don Carlos. He was intended for the church, but his own bent was towards war, and in 1570 he received the command of an army sent against the rebellious Moors in Granada, whom he completely rooted out of the country—signalling himself at once by valour and by cruelty. On the 7th October 1571, with the united fleets of Spain, the pope, and Venice, he defeated the Turks in the glorious battle of Lepanto. Discord breaking out among the allies, Don John separated himself from the rest, took Tunis, and conceived the scheme of forming a kingdom for himself in the north of Africa. But Philip, jealous of this design, sent him to Milan to observe the Genoese; and afterwards, in 1576, as viceroy to the Netherlands. In this capacity he sought to win the favour of the people by mildness; but being left unsupported by Philip, he was hard pressed for a time, till the arrival of the Prince of Parma with troops enabled him to restore the fortunes of Spain by the victory of Gemblours over William the Silent in 1577. But Philip was now apprehensive that he might make himself king of the Netherlands, and Don John's untimely death in his entrenched camp at Namur, on 1st October 1578, was not without suspicion of

poison. See Sir W. Stirling-Maxwell's magnificent work, *Don John of Austria* (2 vols. 1883).

John of Gaunt, Duke of Lancaster, fourth son of Edward III., was born 24th June 1340 at Ghent, during his father's visit to Flanders. In 1359 he married Blanche, heiress of the duchy of Lancaster, and himself was created duke in 1362. Three years after her death he married in 1372 Constance, daughter of Pedro the Cruel of Castile, and assumed the title of king of Castile, though the country and crown were seized and held by Henry of Trastamare. The military expeditions which John organised against his rival all proved unsuccessful. Towards the close of his aged father's reign John gradually became the most influential personage in the realm. He was an ambitious man, and put himself in opposition to the party of his brother the Black Prince, and is suspected of having entertained the design of succeeding his father as king. He also opposed the party of the clergy, and lent support to Wyclif and his followers. But he was very unpopular with the common people; and during Wat Tyler's revolt they burned his palace of the Savoy, in London. The young king Richard, distrusting him too, contrived to send him away on another expedition for the recovery of his crown in Spain. On this occasion John concluded a definite peace with Henry of Trastamare, in virtue of which John's daughter Catharine should succeed as queen of Castile. On his return to England after three years' absence he was able to reconcile the young king to his (John's) brother Thomas of Woodstock, Duke of Gloucester. After this Richard II. seems to have reposed more confidence in John, for he made him Duke of Aquitaine, and entrusted him with several embassies to France. But John of Gaunt gradually ceased to be a factor in English politics, and died on 3d February 1399. On the death of his second wife he had married in 1396 his mistress, Catharine Swynford, by whom he was already the father of three sons and a daughter. These were legitimated in 1397, and from the eldest was descended Henry VII.

John of Leyden (properly John Benckelszoon, Benekels, or Boekhold) was born at Leyden in 1509. He wandered about for some time as a journeyman tailor, settled in Leyden as merchant and innkeeper, and was noted for his abilities as an orator. Adopting the opinions of the Anabaptists, he became one of their wandering prophets. In 1533 he came to Münster, and, when Matthiesen lost his life in 1534, became his successor. Setting up in Münster 'the kingdom of Zion,' he applied in an extravagant manner the principles of the Old Testament theocracy, and established polygamy and community of goods. In June 1535 the city was taken by the Bishop of Münster. John and his chief accomplices suffered death with circumstances of fearful cruelty (January 26, 1536). See ANABAPTISTS; and Hamerling's *König von Zion*.

John of Nepomuk. See NEPOMUK.

John of Salisbury. See SALISBURY.

John o' Groat's House, in Caithness, 1½ mile W. of Duncansby Head, and 18 miles N. of Wick, was, according to tradition, an octagonal building with eight doors and windows and an eight-sided table within, built by John o' Groat to prevent dissensions as to precedence among the eight different branches of his family. Whatever the origin of the legend, which resembles that of the Round Table, it is certain that between 1496 and 1525 there was one 'John o' Groat of Duncansby, baillie to the Earl in those parts,' and probably a Hollander. An outline on the turf marks the site of the house; and the neighbouring hotel (1876) has, appropriately enough, an octagonal

tower. 'Frae Maidenkirke to John o' Groat's' (Burns) is the Scottish equivalent of 'from Dan to Beersheba,' Maidenkirke being Kirkmaiden in the Mull of Galloway. For 'John o' Groat's buckies,' see COWRY.

John, PRESTER. See PRESTER JOHN.

John the Baptist, the forerunner of Christ, was the son of the priest Zacharias and Elizabeth, the cousin of Mary, the mother of our Lord. He was a Nazirite from his birth, and he prepared himself for his mission by years of self-discipline in the desert, until at length he appeared to startle his hearers with the preaching of repentance. The rite of baptism which he administered was a token and symbol of repentance and forgiveness of sins, preparatory to that baptism to follow, the distinctive quality of which was to be the gift of regeneration through the power of the Holy Spirit. With the baptism of Jesus the more especial office of the forerunner ceased, and soon after his ministry came to a close. He had fearlessly denounced Herod Antipas for taking Herodias, his brother Philip's wife, and was accordingly flung into prison, where ere long he was executed at the request of Salome, the daughter of the abandoned Herodias. The Mandaeans or Sabians (q.v.) still claim to be his disciples. John the Baptist was from an early date regarded in England as the patron saint of the common people, and great masonic festivals continue to be held on St John's Day, the 24th of June. For the Knights of St John, see HOSPITALIERS.

John's, EVE OF ST, one of the most joyous festivals of Christendom during the middle ages, celebrated on midsummer eve. From the account given of it by Grimm in his *Deutsche Mythologie* it would appear to have been observed with similar rites in every country of Europe. Fires were kindled chiefly in the streets and market-places of the towns; sometimes they were blessed by the parish priest, but, as a rule, they were secular in their character. The young people leaped over the flames, or threw flowers and garlands into them, with merry shoutings, songs, and dances. In England the people on the Eve of St John's went into the woods and broke down branches of trees, which they brought to their homes and planted over their doors, to make good the prophecy respecting the Baptist, that many should rejoice in his birth. It was a lingering belief of the Irish peasantry that the souls of all people on this night leave their bodies, and wander to their ultimate place of death by land or sea—a notion that may throw light on the widespread custom of watching or sitting up awake on St John's eve. In England it was believed that if any one sat up fasting all night in the church porch he would see the spirits of those who were to die in the parish during the ensuing twelve months come and knock at the church door in the order and succession in which they were to die.

Johns Hopkins. See HOPKINS.

Johnson, ANDREW, seventeenth president of the United States, was born at Raleigh, North Carolina, December 29, 1808. His parents were in humble circumstances, and his father was drowned while attempting the rescue of a friend when Andrew was but four years old. At the age of ten he became a tailor's apprentice, and with the help of a fellow-workman learned to read. In 1824 he went to Laurens, South Carolina, to work as a journeyman, and two years later emigrated to Greenville, Tennessee. There he married Eliza McCardle, a young girl of education and refinement, who taught him to write, and in other

ways helped on his studies. He served as alderman and then as mayor for several years; in 1834 took part in framing the new state constitution; and in 1835 and 1839 was elected a member of the legislature. In 1840 he was chosen presidential elector-at-large, and cast his vote for Martin Van Buren. In 1841 he was elected to the state senate, and in 1843 to congress. Successive re-elections continued him a member of the House of Representatives until 1853, when he was chosen governor of the state of Tennessee, and in 1855 he was re-elected to that office. In 1857 he was sent to the United States senate for six years. There he was an earnest advocate of the Homestead Law and other measures for the benefit of working-men. He was a sturdy opponent of all secession and disunion schemes.

When the war broke out in 1861 he found himself in accord with the administration, and during its progress was a leader of the Southern Union men. His efforts and sacrifices in behalf of the Union led to his selection by President Lincoln as military governor of Tennessee (1862), and subsequently to his nomination and election to the vice-presidency (inaugurated 4th March 1865). On the assassination of Lincoln (14th April 1865) he became president. He sought to carry out the policy of his predecessor. He retained all the former cabinet in office, and, when vacancies occurred, filled them with those known to have been Lincoln's personal and political friends. But the assassination had provoked a revulsion of public feeling. Many who had favoured amnesty, leniency, and reconciliation now began to doubt whether the states so recently in rebellion could safely be restored to a share in the government without further guarantees. Congressional sentiment divided on the question of 'reconstruction.' President Johnson's policy was first distrusted, and then denounced as evincing disloyal sympathies. Irritated at the misconstruction of his motives, and resenting the charge of disloyalty as insulting, he retorted by speeches full of bitter and violent invective. This intensified the ill-feeling. Soon a majority of the congress, elected with him, were opposing his policy. While he urged the readmission of Southern representatives to seats, the congressional majority insisted that the Southern states should be kept for a period under military government, until they gave more proof of loyalty. President Johnson vetoed the congressional measures; and the congress passed them over his veto. Extra sessions were held to keep him in check, and laws passed to limit his power. Finally, his removal of Secretary Stanton from the war department precipitated a crisis. He claimed the right to change his 'constitutional advisers' in cabinet, and in return he was charged with violation of the 'Tenure of Office Act,' in doing so without the consent of the senate. Articles of impeachment were presented, and he was formally brought to trial before the senate. The trial resulted in his acquittal, less than two-thirds of the senators voting for conviction (see IMPEACHMENT). Practically this ended the contest, as the election of 1868 was close at hand, at which his successor was to be chosen. Retiring from office in March 1869, he returned to Tennessee. He was an unsuccessful candidate for congress in 1872, but was elected to the United States senate in January 1875, and again took his seat in that body. On 31st July of the same year he died from a stroke of paralysis.

Johnson, RICHARD MENTOR, vice-president of the United States, born in Kentucky in 1781, was admitted to the bar, and was a member of congress from 1807 to 1809, of the United States senate till 1829, and of congress again till 1837. He served with great bravery in the war with Britain in

1812-13. In 1837-41 he was vice-president under Van Buren. He died at Frankfort, Kentucky, 19th November 1850.

Johnson, SAMUEL, so famous in his own day as a lexicographer, an essayist, and a critic, and still so famous, though rather perhaps for personal than for literary reasons, rather as a brilliant conversationalist and a sincere and brave man than as a writer of the highest order, was born at Lichfield, September 18 (N.S.), 1709. His father, Michael Johnson, a native of Derbyshire, of obscure extraction, was an old bookseller—what we call a second-hand bookseller—and seems to have been a person of some mark and importance in his neighbourhood, where booksellers of any kind were then scarce. 'He propagates learning all over the diocese,' wrote Lord Gower's chaplain in 1716, 'and advanceth knowledge to its just height; all the clergy here are his pupils, and suck all they have from him.' His municipal position, too, was good. He served the offices of junior bailiff, of sheriff (the city of Lichfield being then styled a county), of mayor. His wife, Sarah Ford, came of a yeoman's family living in Warwickshire, and seems to have been a woman of some capacity. Thus his early circumstances were not so unfriendly to the future lexicographer as they are sometimes represented. On the other hand, he inherited from his father 'a vile melancholy,' a terrible tendency to depression and despair, which never wholly ceased to dominate him, and possibly some tendency to superstition, as he was credulously taken up to London to be 'touched' for the 'king's evil,' being afflicted with scrofula. Moreover, his father did not prove a successful man of business, however notable his knowledge of books; and pecuniary troubles soon began to be felt. Thus in his social rank, and his early experience of comfort followed by adversity, Johnson's early life closely parallels that of Shakespeare. He was sent to a dame's school, and then to the Lichfield grammar-school (1716-26), and for a while to the school of Stourbridge; and then for two years (1727-29) he studied or idled at home. All through life he was of indolent habits; but his quickness of apprehension and his strength of memory were amazing. As some one said of him, he 'tore out the heart of books.' And so during his school-days he became a prodigy of learning. Probably the hours spent at will amidst his father's books did more to make him so than the lessons and the floggings of Messrs Hawkins and Hunter, and Mr Wentford. At last, in 1729, probably through the assistance of his godfather, Dr Swinfen, he went up to Pembroke College, Oxford. His attainments were soon recognised; a Latin translation of Pope's *Messiah* increased his fame; and he became a figure of note and of influence in the 'nest of singing birds' of which he was a member. But he was 'miserably poor;' though then, as always, he bore his poverty without complaining or in any way abating his independent spirit. When some well-intentioned fellow-student placed at his door a pair of new boots, of which he stood sorely in need, he flung them out of the window. In the year 1731 things grew worse and worse; he left Oxford finally in October, without a degree; in December his father died.

The terrible struggle with poverty which began at Oxford, or even earlier, lasted some thirty years more (1731-62), and might never have ceased but for the intervention of the royal bounty. For some years after he left the university his life is obscure. He attempted schoolmastering, as do so many when there is nothing else before them, though he could scarcely have been less well fitted for such work physically or in his habits than in fact he was. He was liable to convulsive starts and facial contortions; and he never learned how to

control his temper. 'He has the character,' says an extant letter concerning one of his candidatures, 'of being a very haughty, ill-natured gentleman; and that (*sic*) he has such a way of distorting his face (which though he can't help), the gentlemen think it may affect some young lads.' After a few months at Market Bosworth, he relinquished a situation which all his life long he recollected with 'the strongest aversion and even a degree of horror.' Clearly he liked the pedagogic profession as little as it liked him. He now made approaches towards the career to which he was destined. Visiting Birmingham in search of employment, he began his connection with the press by producing an abridged translation of Lobo's *Voyage to Abyssinia*. Also, he wrote to Cave, the proprietor of the *Gentleman's Magazine*, then recently started, proposing to become a contributor. In 1735, his fortunes being at their lowest ebb, he, aged twenty-five, was bold enough to marry the widow of a Birmingham mercer, aged forty-six. She brought him a portion of £800, part of which seems to have been lost by the insolvency of an attorney. The accounts given of his 'pretty charmer,' as he called her, are not very fascinating; but, as he said in after years to Beauclerk, 'Sir, it was a love match on both sides.' And certainly his attachment, at all events, was deep, and tender, and constant. Once more, and no doubt with the remainder of his wife's portion, he attempted schoolmastering; but it is not surprising that parents did not crowd with their offspring to the boarding-house opened at Edial Hall, near Lichfield. There was now nothing for it but to try the metropolis. In 1737, with a tragedy and twopence-halfpenny in his pocket, he came up, along with his Edial pupil, Garrick, to London, which henceforward was to be his abode. Later in the year he fetched Mrs Johnson. It is certain he had a terrible struggle to make a living. One publisher, noticing his burly frame, advised him to buy a porter's knot; another gave him the task of compiling a catalogue of the Harleian Library, and him Johnson knocked down with a folio Septuagint when he accused him wrongfully of negligence. He was sometimes dinnerless (*yours, impronatus*, is his signature to a letter to Cave), occasionally bedless (we hear of his walking round St James's Square with Savage all one night 'for want of a lodging'), always ill fed and shabbily dressed. But he bore all with a splendid courage. He neither whined about hardships he had to endure, nor boasted of the fortitude with which he endured them. There is no more heroic figure in the history of our literature. Meanwhile, in spite of circumstances, he was becoming the foremost writer of his time, and was already obtaining an influence and a power due to something more than his writings—due to the force and the nobility of his character. In 1738 he became a regular contributor to the *Gentleman's Magazine*, and from November 1740 to February 1743 he wrote the debates in parliament published by Cave under the title of *The Senate of Lilliput*, and 'took care that the Whig dogs should not have the best of it.'

In 1738 he attempted to do with Juvenal what Pope had been doing with Horace; he published his *London*, a poem between whose lines may be read the piteous story of the harsh experiences he was undergoing. It is interesting to note that Pope on first reading the poem promised that its unknown author should soon be *déterré*, and got Lord Gower to write to a friend to beg Swift to obtain Johnson a Dublin degree in order to help him to a mastership of £60 a year. A few years later, in 1747, he published his proposal of a new Dictionary of the English Language. It was paradoxical indeed that one in his starving position should undertake a task

so gigantic and so unremunerative. But it was not only undertaken, but achieved. Just when this huge labour was nearing completion a nobleman whose help at an earlier period would have been three welcome extended towards him a patronising hand; and to this overture Johnson replied in the famous letter of February 7, 1755, which for its just indignation, and its passion of independence, to say nothing of its fine quality as a piece of writing, would make its author memorable had he no other claim on the admiration of posterity. During the years mainly devoted to the Dictionary he had produced also his *Vanity of Human Wishes*, another and yet more brilliant adaptation of Juvenal, and also the series of essays called *The Rambler*, in which his genius showed to less advantage, though it is frequently perceptible in the acuteness of the observations he records. In 1752, just after he had concluded *The Rambler*, his wife died. His grief was profound and enduring. For some forty days this man who to the world at large seemed, and often in manner was, so rough and savage, buried his face and wept. 'Sir,' he said some years after to an old fellow Oxonian who asked him if he had been married, 'I have known what it was to have a wife, and I have known what it is to lose a wife. It had almost broke my heart.' Indeed, one of the most striking characteristics of Johnson, when he is seen beneath the surface, is the infinite tenderness of his nature to children, to women, to poverty, and to every form of distress. As Garrick put it, he had nothing of the bear but the skin. During nearly all the Dictionary period and three years beyond it—i.e. from 1748 to 1758—he was living in a house still standing in Gough Square, off Fleet Street. In 1759 his mother died; and to meet the expenses connected with her death he wrote *Rasselas* in the evenings of a single week. The novel had lately arisen in our literature; and so this work took the shape of a tale. But Johnson had little talent for that kind of writing; and the value of *Rasselas* lies in far other directions. In respect of its view of life, it has been well described as but a prose edition of the *Vanity of Human Wishes*; and it has much in common, though the differences also are striking, with Voltaire's *Candide*, which was published almost exactly at the same time. In 1758 he again attempted the periodical essay, adopting *The Idler* for his title. During all these years he performed also much hack work. Yet, for all his efforts, he was more than once arrested for debt.

At last he was relieved from his oppressive and incessant penury by the bestowal upon him by the crown of a well-deserved pension of £300 a year. And for the last twenty-two years of life (1762-84) he lived in what was comparative affluence, finding himself able to accommodate in his house in Johnson's Court, whither he migrated in 1765, and mainly to support two homeless friends—viz. Mrs Williams and Mr Levett, as well as his black servant Francis Barber; and in his house in Bolt Court, which he occupied from 1777 to his death, no less than three others besides—viz. Mrs Desmoulin and her daughter, and a Miss Carmichael, to say nothing of occasional waifs and strays for whom he provided a night's lodging. These strange inmates of what he called his 'seraglio' were far from being always harmonious, but all their petulance could not weary out his benevolence. We read of his carrying home a poor creature he found lying on the streets upon his back, and putting pennies into the hands of the sleeping street Arabs on his way home from the club, that they might have something for breakfast when they awoke in the morning. In the London of that day he filled an almost,

if not quite, unique position. He was a sort of literary monarch. 'He seemed to me,' said one of his many friends, 'to be considered as a kind of public oracle, whom everybody thought they had a right to visit and consult.' In 1763 the lion-hunting Boswell became his eager and faithful follower, and treasured up with wonderful skill every roar that was uttered. It is mainly to his faithful and reverent recollection that we owe our intimate knowledge of the peculiarities of the great man—his insatiable tea-drinking, and love of late hours; his slovenliness in dress and strange gesticulations; his physical strength and courage; his antipathy to Scotchmen, and love of London streets; his insensibility to music and painting; his hearty old Toryism, hatred of Whigs, and honest old-fashioned patriotism; his reverence for the church, and his sincere religion yet strange shrinking from death; his abhorrence of all false sentimentality, and rigid truthfulness; his delight in conversation, his marvellous dexterity in retort, and his frequent browbeating of his antagonists. Even his cat Hodge has become a living personality to posterity from the inspired faithfulness of his chronicler.

In 1764 the famous club known as the Literary Club was formed, having amongst its original members Johnson, Reynolds, Burke, Goldsmith, Langton, Sir John Hawkins. Probably in 1765 Johnson made the acquaintance of Mr Thrale and his sprightly wife, who made a new home for him both in Southwark and at Streatham, and in other ways did much to make his life bright and happy for the long space of more than sixteen years. With them he travelled to Bath, to Brighton, to North Wales, to France. In 1773 Boswell persuaded him to visit Scotland and the Hebrides, which was perhaps the most striking event of his later years. So far as his terrible enemy melancholia permitted, he found life worth living and pleasant to live during this period. He delighted to fold his legs and have out his talk; and there was no lack of appreciative and reverent listeners. But he wrote little. To set himself to write was always an effort; and he shrank from making it. His best thought and wit found an outlet in conversation. His *Journey to the Hebrides* and his *Lives of the Poets* are the only works of any importance belonging to this time of his kingship. Some time in March 1781, he writes, 'I finished the *Lives of the Poets*, which I wrote in my usual way, dilatorily and hastily, unwilling to work and working with vigour and haste.' Meanwhile, his social circle began to be sadly invaded and broken. Goldsmith died in 1774, Garrick in 1779, Beauchamp in 1780, Mr Thrale in 1781, and Levett, whom he commemorated in a touching poem, in 1782. For a while after her husband's death Mrs Thrale kept up the old relationship, but by the autumn of 1782 she had determined to marry Piozzi, an Italian musician and Catholic, and Johnson's displeasure at what he considered a degrading step at length dissolved a friendship which had 'soothed twenty years of a life radically wretched.' The marriage actually took place in June 1784, less than six months before Johnson's death. In 1783 Mrs Williams passed away; and for all her peevishness was sincerely missed. For Johnson, too, the end was approaching. In 1783 he suffered a paralytic stroke. He rallied to some extent, and was once more seen in his old haunts. But in the following year dropsy and asthma attacked him. By November there was but little hope of his recovery. All that medical skill and all that the tenderest affection could do to relieve and to smooth his dying hours was faithfully done. He took solemn leave of Langton, Burke, Reynolds, and other dear friends he had loved with a constant

affection, and sent a tender blessing to his young favourite Fanny Burney, who watched weeping at his door. 'I am afraid,' said Burke one day, 'that so many of us must be oppressive to you.' 'No, sir, it is not so,' replied Johnson, 'and I must be in a wretched state indeed when your company would not be a delight to me.' 'My dear sir,' said Burke, with a breaking voice, 'you have been always too good to me,' as he left him for the last time. The brave-hearted Johnson faced the inevitable with heroic courage, refusing at the last to take his opiates, that he might 'render up his soul to God unclouded.' He died on the evening of December 13, and he was buried in Westminster Abbey near Garrick, Dryden, and Cowley. A monument was raised to him in St Paul's.

The estimate of him as a writer is by no means so high now as in his own day. As a writer, it must be said of him that he was rather of an age than for all time. His greatest interest for us is that he so exactly represents the current ideas of his age, such as they were. He never fully expressed himself in literature. And, excellent as are several of his works, or at least passages in them, we should never have known his real greatness but for Boswell's admirable portraiture of him, and his masterly reports of his conversations. Boswell's skill in these respects is beyond praise, and deserves a better acknowledgment than Macaulay and some other critics have vouchsafed him. In Boswell's pages Johnson will live for ever, and he better known than anybody that ever lived. And the more he is known, the more readily will be recognised the nobleness of his nature, the vigour of his genius, and the value of his literary services.

Editions of his works have been numberless; the best is that published at Oxford in 11 vols. in 1825. See the article BOSWELL, the Life by Sir J. Hawkins (1787), and the editions of Boswell's *Life of Johnson* by Croker, Napier, Henry Morley, and Birkbeck Hill; the *Essays* by Arthur Murphy, Macaulay, and Carlyle, as well as Macaulay's perfect biography in miniature, contributed to the *Encyclopædia Britannica* (1856); also Birkbeck Hill's *Dr Johnson, his Friends and his Critics* (1878), his edition of the *Letters* (2 vols. 1892); Leslie Stephen's admirable book in 'English Men of Letters' (1878), and the little book by Col. F. Grant in 'Great Writers' (with a bibliography, 1887). Matthew Arnold edited the chief six of the *Lives of the Poets* (1878); a good edition of the whole is that by Mrs Napier (1890). See also Madame D'Arblay's *Diary and Letters*, Mrs Piozzi's *Autobiography*, and Mrs Napier's *Johnsoniana* (1884)—the last made up from the writings of Mrs Piozzi, Richard Cumberland, Bishop Percy, T. Tyers, Dr Campbell, Hannah More, Madame D'Arblay, Rev. T. Twining, Miss Reynolds, Sir Joshua Reynolds, and Arthur Murphy.

Johnson. ALBERT SIDNEY, an American general, was born in Kentucky, 3d February 1803, graduated at West Point in 1826, and served in the United States army until 1834. In 1836 he joined the army of Texas as a private soldier, but very shortly became its head; in 1838 he was appointed war secretary of the young state, and in 1839 drove the marauding Indians out of northern Texas. He served in the Mexican war under General Taylor, who in 1849 appointed him a paymaster in the United States army. In 1855 he received a cavalry regiment, and in 1858 he brought the Mormon rebellion to an end without the employment of force. He was then appointed brigadier-general, and commanded in Utah and in the department of the Pacific until 1861, when he resigned and passed over to the South. Appointed to the command of the department of Kentucky and Tennessee, he fortified Bowling Green, and held the Northern army in check until February 1862, when he retreated to Nashville and, on the fall of Fort Donelson, to Corinth, Mississippi. Here he con-

centrated 50,000 men, with which force he attacked Grant at Shiloh before daybreak on Sunday, 6th April 1862. The National army was surprised, and the advantage in the tremendous battle that ensued lay with the Confederates when, at half-past two, while leading a charge, Johnston was mortally wounded. The next day Grant's supports came up, and the enemy, now under Beauregard, was driven back to Corinth. There is a Life of General Johnston by his son (New York, 1878).

Johnston. ALEXANDER KEITH, LL.D., F.R.S.E., cartographer and geographical publisher, was born near Edinburgh, December 28, 1804. His first important work, the *National Atlas* (fol.), occupied him for five years, and was published in 1843. Its merits received immediate recognition, and Johnston was appointed Geographer Royal for Scotland. Acting on a suggestion from Humboldt, he visited Germany, and gathered material for his *Physical Atlas* (1848; 2d ed. 1856). Its publication was the signal for a shower of honours from the geographical societies of Europe. In 1850 appeared a very useful *Dictionary of Geography*, better known as 'Johnston's Gazetteer.' In 1851 he constructed the first physical globe, showing the geology, hydrography, &c. of the earth. His *Royal Atlas of Geography* (1861) was one of the most beautiful and minutely accurate atlases ever executed up till that time. Johnston also published atlases of Astronomy and Geology; a *Military Atlas* for Alison's *History of Europe*; besides educational atlases, physical, general, and classical, which obtained a wide circulation. He died 10th July 1871.—His son, ALEXANDER KEITH, born in 1844, was educated in Edinburgh, trained as a draughtsman in his father's firm, and afterwards extended his experience in London and Germany. He took part in an exploring expedition to Paraguay in 1874, and in 1879 was appointed leader of the Royal Geographical Society's expedition to East Africa, mainly for the purpose of discovering a practical route to the interior. He was scarcely a month on the way when he fell a victim to dysentery at Berobero on the road between Dar-es-Salaam and Lake Nyassa, 28th June 1879. His work was taken up and successfully completed by Mr Joseph Thomson. Johnston, who was a frequent contributor to the *Geographical Magazine*, produced a *Physical Geography* (1877), edited and extended Hellwald's *Africa* (1879) in Stanford's series, and edited a sheet map of Africa and Boyce's *Gazetteer* (1879).

Johnston. or JONSTON, ARTHUR (1587-1641), eminent as a physician and still more so as a humanist, was born of an honourable family at Caskieben, Aberdeenshire, and educated at Marischal College and the university of Padua, where he graduated M.D., June 11, 1610. The same year (says Sir T. Urquhart) he was 'haunted poet at Paris and that most deservedly,' and thereafter visited many seats of learning on either side the Alps from Rome to Sedan, in which latter he sojourned long with his compatriot Andrew Melville, professor of Divinity in the university. For many years he practised medicine in France, whence his fame as a Latin poet spread over Europe. In 1625 appeared in London his elegy on James I., and about the same time he was appointed physician to King Charles. His Latin rendering of the Song of Solomon, dedicated to that monarch (Lond. 1633), contained a specimen of his translation of the Psalms of David into Latin verse, a work on which he had long been engaged, and which was published at Aberdeen in 1637. In that year he helped to bring out the *Delitæ Pœtarum Scotorum hujus Ævi Illustratum* (Amsterdam, 2 vols. 12mo), a collection in

which the scholarship, taste, and poetical power of his countrymen appear to signal advantage, and to which his own contributions are at once the most numerous and the best. On June 24, 1637, he accepted the post of rector of King's College, Aberdeen, and enhanced the lustre of that brilliant era in the university's annals. His avocations as court physician, however, kept him mainly in England, where his fame as man of letters and poet, as well as physician, was steadily increasing till 1641, when he died suddenly on a visit to Oxford. His translation of the Psalms, often reprinted at home and abroad, divides with Buchanan's still more famous version the palm of superiority in that field; but his command, at once comprehensive and refined, of Latin idiom and rhythmical movement, and his imagination, rich without extravagance, are even more conspicuous in his miscellanies, among which his prolation on the great anatomist Casserio would suffice to keep him in the front rank of modern Latin poets. See the monograph by Principal Geddes of Aberdeen (1890).

Johnston, JAMES F. W., a Scottish chemist, was born at Paisley in 1796. He was of humble parentage, and studied at Glasgow University. Having in 1830 married a lady of considerable fortune, he repaired to Stockholm, and became the pupil of Berzelius, the chemist. In 1833 he was invited to take the readership in chemistry and mineralogy in the newly-established university of Durham. But he resided chiefly in Edinburgh, and there carried on his investigations. It is as an agricultural chemist that he is chiefly known. His *Catechism of Agricultural Chemistry and Geology* has gone through more than fifty editions, and has been translated into almost every European language; and his *Lectures on Agricultural Chemistry and Geology* (1842; 17th ed. 1894) are held in high esteem. The last of his works, *Chemistry of Common Life* (1854), has passed through several editions (one edited by Church in 1879). He died at Durham, 18th September 1855.

Johnston, JOSEPH EGGLESTON, an American general, was born in Virginia, 3d February 1807. His mother was a niece of Patrick Henry. He graduated at West Point in 1829, fought in the Seminole war, became captain of engineers in 1846, served with great gallantry in the war with Mexico, where he was wounded at Cerro Gordo—he received altogether ten wounds in the three wars he was engaged in—and in 1860 was commissioned quartermaster-general, with the rank of brigadier-general. He resigned in 1861 to enter the Confederate service, and was appointed brigadier-general and given the command of the Army of the Shenandoah; in August he was made full general. He came to the assistance of Beauregard at the first battle of Bull Run, but waived his claim to precedence, and left him in command. In 1862 he was for several months disabled by a wound received at Seven Pines, while opposing McClellan. In 1863, with a weak force, he failed in an endeavour to relieve Vicksburg. He commanded the force directed to oppose Sherman's advance towards Atlanta, in 1864, and stubbornly contested his progress; he was steadily driven back, however, and in July was relieved of his command. He was again placed in command by General Lee in February 1865, and ordered to 'drive back Sherman'; but he had only a faint of the Northern general's strength, and after a last vigorous resistance at Bentonville, in March, and after learning of Lee's surrender, he accepted the same terms on 26th April. General Johnston afterwards engaged in railway and insurance business, and was elected to congress by Richmond in 1877. He was appointed United States commis-

sioner of railroads by President Cleveland. He died 21st March 1891. See his *Narrative of Military Operations* (1874), and Lives of him by Johnson (1891) and R. M. Hughes ('Great Commanders' series).

Johnstone, a manufacturing town of Renfrewshire, on the Black Cart, 3½ miles W. by S. of Paisley. Founded in 1781, it contains a large flax-mill, cotton-mills, a paper mill, foundries, and machine-shops. Pop. (1831) 5617; (1891) 9668.

Johnstone, FAMILY OF, takes its surname from the lordship of Johnstone in Annandale, Dumfriesshire. In former days it was one of the most powerful and turbulent clans of the west Borders, and was at constant feud with its neighbours, especially the Maxwells. Three branches of the name still exist, Johnstone of Annandale, Johnstone of Westerhall, and Johnston of Hilton and Caskieben in Aberdeenshire. The first named, which retained the ancient patrimony, was ennobled by Charles I., and became successively Lords Johnstone of Lochwood, Earls of Hartfell, and Earls and Marquises of Annandale. These titles, being limited to heirs-male, became dormant in 1792, and more than once rival claims for their revival by the Annandale and Westerhall branches have been repelled by the House of Lords. Both the houses of Westerhall and Caskieben enjoy knightly rank, and a branch of the former was in 1881 raised to the peerage as Baron Derwent.

Johnstown, (1) capital of Fulton county, New York, on Cayadutta Creek, 48 miles WNW. of Albany, and 6 miles S. of Gloversville by rail. It has some mills and large manufactories of gloves and mittens. Pop. 5013.—(2) A town of Pennsylvania, on the Conemaugh River, 78 miles E. by S. of Pittsburg by rail, with large iron and steel works, tanneries, and flour, planing, and woollen mills. Johnstown was overwhelmed by the bursting of a reservoir on 31st May 1889. Pop. (1880) 8380; (1890) 21,805.

Johore, an independent state at the southern extremity of the Malay Peninsula, with an area of 10,000 sq. m. The country is densely covered with timber, and rises into several mountain-peaks, the highest being Mount Ophir (4186 feet). The population numbers about 200,000, mostly Malays and Chinese. The former live by fishing and wood-cutting; the latter are traders and shopkeepers. The chief staples of the country are tea, gambier, and black pepper. All kinds of fruit are plentiful. The climate is tropical but healthy. The capital is Johore, 15 miles NE. of Singapore.

Joiny (anc. *Jovinicum*), an old walled town in the French department of Yonne, 90 miles by rail SE. of Paris, manufactures cloth, linen, and sporting rifles. Pop. 6189.

Joinery. See CARPENTRY.

Joint-fir. See SEA-GRAPE.

Joints, in Anatomy. A joint or articulation may be defined to be the union of any two segments of the skeleton of an animal body, through the intervention of a structure or structures of a different nature. The textures which enter into the formation of the more complex joints are bone, cartilage, fibro-cartilage, ligaments, and synovial membrane. Bone forms the fundamental part of all joints; ligament, in various modifications, is employed as the bond of union between the bony segments; while the three remaining textures chiefly occur in those joints in which there is free motion. The joints vary in the degree of motion from almost perfect immobility to the greatest amount and extent of motion that are compatible with the maintenance of the bony segments in their proper relation to each other.

Joints have been divided by anatomists into two great classes—the *Immovable* and the *Movable*. In the immovable or *Synarthroses* the parts are continuous, that is to say the bones are united together by a prolongation of the periosteal fibrous membrane between them. In some cases the uniting medium is a plate of cartilage. There is no synovial sac intervening between the bones. In movable joints the articular surface of each of the bones is covered with cartilage, and these cartilaginous plates are separated from each other by a synovial sac more or less complete. This sac is lined by a membrane which secretes a viscid fluid for lubricating the articular surfaces—the *synovia* or joint-oil.

In synarthroses the articulation is said to be by *suture* when the bones seem to grow somewhat into one another, and to become interlocked and dovetailed together, each bone having a jagged or serrated margin, or when there is a degree of beveling, so that one bone is overlapped by the other. Both these kinds of suture are at once seen in the human Skull (q.v.).

The movable joints are *Amphiarthroses* and *Diarthroses*. In the former there is partial mobility of one bone upon another, combined with great strength. The contiguous surfaces of the bones are united by a thick and strong layer of fibro-cartilage, the centre of which is usually soft, and may present a cavity lined by a synovial membrane, with which a little elastic tissue is intermixed. As examples of this kind of joint may be mentioned the articulation between the bodies of the vertebrae and that between the two pubic bones at what is termed the symphysis.

Diarthroses are complete joints, the articular surfaces being covered by articular cartilage and separated from each other by a cavity lined by synovial membrane. In these the degree and nature of the motion are very various. There may be merely a little *gliding* motion between the ends of the bones, as, for example, in the articulations between the various bones of the carpus and tarsus. (see HAND, FOOT). In these cases the surfaces are plane, or one is slightly concave and the other slightly convex; and the motion is limited in extent and direction by the ligaments of the joint, or by some projecting point of one of the bones. In some cases, instead of a slight concavity and convexity, one bone presents a cup-like depression, while the termination of the other assumes a hemispherical, or more or less globular shape. Hence the name of *ball and socket* that is applied to such joints. The best example of this variety is the Hip-joint (q.v.), and the next best is the shoulder. In these joints the ball is kept in apposition with the socket by means of what is termed a *capsular* ligament, which may be described as a barrel-shaped expansion of ligamentous structure, attached by its extremities around the margin of the articular surfaces composing the joint, and forming a complete investment of it, but not so tight as materially to restrict its movements. This species of joint is capable of motion of all kinds.

Another important variety of articulation is the *hinge-joint*, in which the contiguous surfaces are marked with elevations and depressions, which exactly fit into each other, so as to restrict motion to one plane. The elbow and ankle joints, and the joints of the fingers and toes, are the best examples of this variety. The knee-joint is a less characteristic example, because in certain positions it is capable of a slight rotation. These hinge-joints are always provided with strong lateral ligaments.

The last kind of joint requiring notice is that which admits only of *rotatory* motion. A pivot and a ring are the essential parts of this joint, the ring being generally formed partly of bone and

partly of ligament. The best example of this articulation is that between the atlas (the first vertebra) and the odontoid or tooth-like process of the axis (the second vertebra). See HAND.

Diseases of the Joints.—In diseases of the joints we may have one or more of the following textures affected: (1) the synovial membrane; (2) the cartilage; and (3) the bones themselves. The synovial membrane may undergo either acute or chronic inflammation, giving rise to the serious affections known as acute and chronic Synovitis (see SYNOVIAL MEMBRANES). Loose substances of a fibrous structure, and usually resembling a small bean in size and shape, sometimes occur in joints, especially in the knee-joint. They commence as little pendulous growths upon the synovial membrane, which after a time become detached. The cartilage may be affected in various ways. There may be (1) simple destruction of cartilage; (2) scrofulous destruction of cartilage; (3) hypertrophy of cartilage; (4) atrophy of cartilage, and other modified forms of disease of this texture, all of which, especially the second, are of a very serious character, but not of a nature that admits of popular explanation. The most important diseases of the osseous structures of the joints are (1) ulcer and (2) caries. These diseases often, but not always, begin with the disorganisation of cartilage, and then extend to the bones. Sometimes, however, they commence in the bones. See ANKYLOSIS.

Resection or Excision of Joints 'is on the whole safer than amputation; less violence is done to the body, fewer great arteries and nerves are injured, and, what is of more consequence, fewer large veins are divided, and as the articular end of the bone only is sawn off, and the medullary canal not touched, there is less chance of pyæmia. Lastly, the patient is left with an imperfect limb, it is true, but with one which, in most cases, is highly useful' (Druitt). The operation has been performed on the shoulder, elbow, wrist, hip, knee, and ankle. Few subjects have in recent times excited more discussion among surgeons than the application of this operation to the knee-joint. The operation was first performed in 1762; and up to the year 1830 there are records of 19 cases, out of which 11 died. From 1830 to 1850 the operation was never performed, and was generally condemned; but in the last-named year it was revived by Professor Fergusson, and is now a frequent and most valuable operation. 'The cases,' says Dr Druitt, 'in which it ought to be performed are, generally speaking, such cases of injury or disease as would otherwise be submitted to amputation. The object of the operation is to produce a firm and useful limb, slightly shortened, and with entire bony union, or fibrous union admitting of some small degree of motion at the situation of the joint. But all cases are not suitable for excision; and those cases are unsuitable and better adapted for amputation in which either the *quantity* of the diseased bone is very great, or the *quality* of the disease may be such as experience has shown to be incompatible with the exudation of healthy material of repair.' In at least 50 per cent. of cases the operation results in a good useful leg. It has already saved so many limbs that it must be regarded as one of the greatest triumphs of modern surgery. Further information on this subject may be found in Holmes's *System of Surgery*, or in any surgical text-book e.g. Erichsen's.

Joints, in Geology, are the natural division-planes or cracks by which rocks of all kinds are traversed. Joints, although very frequently irregular, yet have a tendency to run across rocks in certain directions. Thus, in ordinary bedded aqueous rocks (sandstone, shale, limestone) they are generally developed more or less at right

angles to the bedding, so that, if the strata be horizontal, the leading joints will be vertical or approximately so. Two sets of these joints are usually recognisable (*master-joints*), which cut each other at or nearly at right angles. Hence aqueous rocks, by means of joints and original bedding-planes, are divided into larger or smaller cuboidal blocks. In massive crystalline rocks, such as granite, joints are rarely so regular. Yet even in these two sets of joints, crossing each other, can often be traced; and occasionally another horizontal set may be present—these last simulating the bedding-planes of aqueous strata. Were it not for the presence of such natural division-planes, it is obvious that quarrying would be a much more difficult operation. A peculiar kind of jointing is met with in certain crystalline igneous rocks, as in some fine-grained basalts, in which the division-planes separate the rock into polygonal or more or less perfect hexagonal prisms or columns (see BASALT). Joints have been formed in various ways. They are doubtless due to the strain and tension to which rocks have been subjected during movements of the crust. Others probably owe their origin to contraction on cooling; the prismatic joints of basalt being 'fissures of retreat.' And, in like manner, it seems likely enough that sedimentary strata may sometimes have become jointed during their gradual drying and consolidation.

Joint-stock Company. See COMPANY.

Jointure, in English law, meant originally an estate settled on husband and wife jointly for their lives. Such settlements were made as a substitute for dower, which is that portion of property to which, on her husband's death, the widow is entitled for the maintenance of herself and children—one-third and upwards of the estate for life. The term jointure now includes an estate limited to the wife. The requisites of a jointure are: (1) That it must commence and take effect immediately on the husband's death; (2) it must be for the wife's life, at least; (3) it must be given to the wife herself, and not merely to trustees for her; (4) it must be expressed to be made in satisfaction of her whole dower; (5) it must be made before marriage. The mode of giving a jointure in modern marriage settlements is usually by way of a rent-charge on the husband's real estate. If a jointure be created out of an estate before marriage, the husband cannot sell the estate afterwards, so as to defeat the jointure. A jointure is not lost by the treason or felony of the husband, nor by the elopement and adultery of the wife.

In Scotland the word jointure is also frequently used in a similar sense to denote a conventional provision for a widow, consisting either of an annuity to her or of a life-ent assignment of rents, or of a life-ent of lands, called a locality. In whatever way the jointure is constituted it also excludes the widow's terce, unless it is otherwise expressed.

Joinville, a small town of 4000 inhabitants in the French department of Haute-Marne, 22 miles N. of Chaumont by rail, which was formed into a principality by Henry II., and later supplied the title to the third son of Louis-Philippe.

Joinville, JEAN, SIRE DE, the biographer of St Louis of France, was born in 1224, and became sénéchal to Thibaud, Count of Champagne and king of Navarre. He took part in the unfortunate crusade of Louis IX. (1248-54), returned with him to France, and lived thereafter partly at court, partly on his estates. He declined to go on the fatal expedition to Tunis, and survived till July 11, 1317. During his stay at Acre in 1250, at the age of twenty-six, he occupied his leisure in com-

posing a manual of the Christian faith—his *Credo*, which he retouched thirty-seven years later; and there is extant a letter he wrote to Louis X. at the age of ninety-one. During the crusade he took notes of events and wrote down his impressions. At the age of almost eighty, at the entreaty of Jeanne de Champagne, wife of Philip le Bel, he undertook his *Vie de Saint Louis*, which he finished after the death of his patroness, and presented in 1309 to her son (afterwards Louis X.). The concluding portion of the book bears traces of senility; nothing, on the other hand, is more clear, animated, and real than the part relating to the crusade. Thus the book is obviously a collection of pieces composed at different times. Joinville is an excellent example of the best type of 13th-century cavalier, with all his admirable qualities as well as all his limitations and defects: he is brave, pious, candid, devoted to his king while strictly maintaining against him his feudal rights, considerate for his vassals, a jealous guardian of all traditional privileges; but, on the other hand, his intelligence generally stops short at detail and cannot grasp general causes; he relates unskilful military operations without criticising or apparently even understanding them; he approves intolerance in St Louis, and falls into woeful puerilities in his narration. His style conforms closely to his character: it is veracious, flowing, naive, often singularly expressive, but it has neither the elegance of the best prose-writers of the middle ages nor the vigour and solidity of Villehardouin: it is the tone of an amiable and familiar talker, who sometimes forgets himself a little in his reminiscences, but never fails to charm. The book has the one consummate merit of sympathetically raising up clear before our eyes the breathing image of a romantic figure over whom already there hung the shadow of a tragic destiny.

Unfortunately the text has only come down to us in later MSS. in which the language has been modernised; but the methodical study of competent editors has at length restored with almost complete security both the substance and the form of the book—one of the most precious bequests of the middle ages, holding its place in time between Villehardouin and Froissart. The best edition is that of N. de Wailly (1875). See Duret, *Études sur la Vie et les Travaux de Jean de Joinville* (1870).

Joists. See FLOOR.

Jokai, MAURICE, Hungarian novelist, was born on 19th February 1825 at Komorn. He qualified himself for an advocate, but never practised; literature and journalism were more to his taste. He was an active partisan of the Hungarian struggle in 1848, and when the Austrians gained the upper hand, it was with difficulty that he escaped imprisonment. After 1849 he devoted himself exclusively to literary pursuits. His works number close on 300 volumes, and embrace novels, romances, dramas, humorous essays, poems, &c. Of these the most valuable are the novels and romances, of which *The Turks in Hungary* (1852), *The Magyar Nabob* (1853), and its continuation *Zoltan Karpathy* (1854), *The New Landlord* (1862; Eng. trans. 1868), *Black Diamonds* (1870), *The Romance of the Coming Century* (1873), *The Modern Medea* (1875; Eng. trans. 1885), *The Comedians of Life* (1876), *God is One* (1877), *The White Woman of Leutschau* (1884), and *Tinau's Two Worlds* (Eng. trans. 1888) may be taken as good examples. His skill as a narrator is enhanced by a lively imagination, humour, and a complete grasp of Hungarian life. His work is sometimes marred by improbability, a straining after effect, and superficial treatment. Most of his novels have been translated into German. Jokai has also gained fame as a journalist, as editor first of the revolutionary weekly *Pictures of Life*, then of the political daily *Fatherland*, and lastly of the

humorous weekly *The Comet* (1858-81), and the government organ *Nemzet* ('The Nation'). He is a prominent member of the House of Representatives, being one of the cleverest debaters of the party of the liberal government.

Jokjakarta, a residency of Java, in the central part of the island, has an area of 1191 sq. m., and a population of about half a million, nearly all Javanese; see JAYA. The capital, Jokjakarta, is a town of more than 50,000 inhabitants, with the sultan's palace and ruins of ancient temples.

Joliba. See NIGER.

Joliet, capital of Will county, Illinois, is on Des Plaines River, 35 miles SW. of Chicago by rail, and its water-power is increased by a canal from Lake Michigan. It is the site of the state penitentiary, and has extensive manufactures of flour, steel, rails, wire, stoves, tools, boots and shoes, paper, tiles, cigars, &c. There are large quarries of limestone at Joliet, and a coalfield in the neighbourhood. Pop. (1880) 11,657; (1890) 23,264.

Jolly-boat (Dutch *jolle*, 'yawl'). See BOAT.

Jomelli, NICOLÒ, Neapolitan composer (1714-74), is known by his operas *Armida* and *Ifigenia*, and by a *Miserere* and a *Requiem*.

Jomini, HENRI, BARON, born 6th March 1779 at Payerne, in the canton of Vaud, began his military career in the Swiss Guards at Versailles, and finally rose to be chief of the staff to Marshal Ney; he was created baron after the peace of Tilsit. In 1804 he attracted the notice of Napoleon by his *Traité des Grandes Opérations Militaires*. He distinguished himself at Jena, in the Spanish campaigns of 1808 and succeeding years, during the retreat from Russia, and at Lützen and Bautzen; but, offended at the treatment which he received from Napoleon, he entered the service of Russia in 1814. In 1828 he took an active part in the war Russia waged against Turkey, particularly in the capture of Varna. His fame as a military writer rests upon *Histoire Critique et Militaire des Campagnes de la Révolution* (5 vols. 1806), *L'Art Politique et Militaire de Napoleon* (4 vols. 1827), and *Précis de l'Art de Guerre* (1830; new ed. 1881). Baron Jomini died at Passy, near Paris, 24th March 1869. See the Life by Lecomte (1861); and Sainte-Beuve, in *Nouveaux Lundis*, vol. xiii.

Jonah. The Book of Jonah, unlike the other eleven of the series of the minor prophets in which it occurs, is not a prophetic discourse but a narrative, and does not in any sense claim to have been written by the prophet whose name it bears. It belongs to that special kind of literary composition, common among the late Jews, usually known as haggadic; it is obviously not intended to be taken as literal history, but as a parable attached to a historic name. The name in this instance is that of Jonah, the son of Amittai, who is mentioned in 2 Kings, xiv. 25, as having been a native of Gath-hepher in Galilee, and as having prophesied the victories of Jeroboam II. No writing known to belong to him is now extant; the oracle contained in Isaiah, xvi. xvi., and spoken of by that prophet as already ancient, has been conjecturally attributed to Jonah by Hitzig, but for somewhat inadequate reasons. Whether the story now associated with his name may have had some basis in any word or deed of his, or whether the choice of his name was quite arbitrarily made by the anonymous author, cannot now be determined. The key to the narrative, the details of which are familiar to every one, is to be sought in the closing chapter, where Jehovah asks the prophet whether he does well to be angry because of the sparing of Nineveh, a great city teeming with innocent life for which Jehovah has laboured, and which he has

caused to grow. Nowhere in the Old Testament is that particularism, to which the Jews were ever prone, more clearly or emphatically rebuked. As for the earlier part of the story, its explanation is to be sought in the often-recurring Old Testament figures in which the great world-powers are likened to sea-monsters or dragons (see, for example, Jer. li. 44), and deliverance from any overwhelming calamity is spoken of as a bringing back from the depths of the sea (Ps. lxxviii. 22 [23]). At the time when the Book of Jonah was written, the Jews, who had returned from the Babylonian exile full of bright hopes as to a near and glorious future, had become querulously aware of the failure of these. The object of the writer seems to have been to suggest to them that their existing troubles, in which they seemed as it were to be swallowed up by the world-powers which oppressed them, were due to their neglect of the missionary vocation which had been urged upon Israel by the later prophets (see especially Isa. xl.-lxvi.); once Israel in penitence and prayer shall have shown that she has again become alive to this duty, she may hope to experience the fulfilment of the prophet's words (Hos. vi. 2): 'After two days he will revive us; on the third day he will raise us up.' The prayer of Jonah, whether a composition of the author of the rest of the book or not, certainly cannot be carried back to a date nearly so early as the 8th century B.C.; it is largely a cento from older compositions, the metaphors in verses 3-6 being common in all periods of Hebrew poetry. See the commentaries on the minor prophets mentioned under HOSEA; also Krahnert (1839), Jäger (1840), and F. Bergmann (Strasb. 1885).

Jonas, JUSTI'S (1493-1555), a helper of Luther's in the work of reformation and translation of the Bible, was professor at Wittenberg, pastor at Halle and Coburg, and superintendent at Eisfeld. He took part with Luther in many of the great events of the Reformation, as at Worms, Marburg, and Augsburg. There is a monograph on him by Pressel (1863).

Jonathan, BROTHER, corresponding to the English John Bull, is the personification of the United States, especially of its native born citizens. The original of the name is supposed to be Jonathan Trumbull (1710-85), governor of Connecticut, whose shrewdness, staunch patriotism, and unflinching zeal gained him the esteem and friendship of Washington; and the latter's phrase when perplexed, 'Let us hear what Brother Jonathan says,' passed into a proverb.

Jones, EBENEZER, poet, was born at Islington, 20th January 1820. He was brought up in the strictest sect of the Calvinists, but at thirteen was writing verses, and in secret devouring the Waverley novels. In 1837 he was forced by his father's long illness to turn clerk in a City warehouse; his hours were eight to eight six days a week. Yet he published his *Studies of Sensation and Event* (1843), poems 'full of the very essence of poetry,' and admired by such poets as Browning and Rossetti. But the world rejected them, and he published no more, save a pamphlet on the *Land Monopoly* (1849), which anticipated Henry George by thirty years in proposing to nationalise the land. A Chartist he was not, but a disciple of Carlyle in politics, as of Shelley in poetry. In 1844 he married, miserably, the niece of Edwin Atherstone; and he died at Brentwood, 14th September 1860. See three long articles by Theodore Watts in the *Athenaeum* (1878); and two notices by Sumner Jones (elder brother of the poet, and a poet himself) and W. J. Linton prefixed to a reprint of the *Studies* (1879).

Jones, EDWARD BURNE. See BURNE-JONES.

Jones, ERNEST, Chartist poet, was the son of Major Jones, equerry to the Duke of Cumberland, afterwards king of Hanover. He was born at Berlin in 1819, was educated in Germany, and came to England in 1838. In 1841 he published his romance, *The Wood Spirit*, was called to the bar of the Middle Temple in 1844, and the year following became the most prominent leader of the Chartist movement. He declined all remuneration for his services, and issued *The Labourer*, *Notes of the People*, and the Chartist organ, *The People's Paper*. He voluntarily resigned a fortune of nearly £2000 per annum, left to him on condition that he should abandon the Chartist cause. For the part which he took in the Chartist proceedings at Manchester in 1848 he was condemned to two years' solitary confinement. This vindictive sentence was brought before the House of Commons, but Jones refused to petition for its commutation. While in prison he composed an epic poem, *The Revolt of Hindostan*. The authorities refused him pen, ink, and paper, and the poem was stated to have been written on the leaves of his prayer-book with a bird's feather and blood drawn from his own veins. After his release Jones wrote *The Battleday* (1855); *The Painter of Florence* and *The Emperor's Vigil* (1856); and *Beldouyn Church and Coragda* (1860). He tried for a seat in parliament, but was defeated at Halifax (1847) and Nottingham (1853, 1857). He died 26th January 1869.

Jones, HENRY ARTHUR, playwright, was born at Grandborough, Bucks, 28th September 1851, and was at first in business. *Only Round the Corner* was produced in 1878, but his first hit was *The Silver King* (1882). Other plays are *Saints and Sinners* (1884), *The Middlemen*, *The Daring Girl*, *Rebellions Sussex*, *The Triumph of the Philistines*, *The Lions* (1897), *The Physician*, (1897), &c.

Jones, INIGO, an English architect, was the son of a cloth-worker, and was born in London 15th July 1573. A nobleman sent him to Italy to study landscape-painting, but he was drawn to study architecture instead. While in Venice he paid particular attention to the works of Palladio, whose style he introduced into England, whence he is sometimes called the 'English Palladio.' On leaving Italy he went to Denmark by invitation of Christian IV., and there he is said by some to have designed the royal palaces of Rosenborg and Frederiksborg. Returning to England in 1604, he was employed by James I. in arranging the scenery, &c. for the masques of Ben Jonson, which were at that time the chief amusement of the court. Jonson afterwards satirised his fellow-labourer in *Bartholomew Fair*. In 1612 Jones revisited Italy, still further to improve his style, and on his return to England was appointed surveyor-general of the royal buildings. He was at this time accounted the first architect of England, and, according to some, the first of the age. He died 21st June 1652. His masterpiece is considered to be the Banqueting House (now the Chapel Royal) at Whitehall. Another representative specimen of his work is the church of St Paul, in Covent Garden, London.

See Walpole's *Anecdotes of Painters* (Dallaway's ed. 1828) for the buildings designed by him; his life by Peter Cunningham (1848); Fergusson's *History of Architecture*; and W. J. Loftie, *Inigo Jones and Wren* (1893).

Jones, OWEN, Welsh antiquary, was born in Denbighshire in 1741, and died in London, 26th September 1814. He was all his life a farmer, but had early developed a taste for Welsh poetry. In 1801-7 he published at his own cost the *Mygvaen Archæology of Wales*, a collection of poetic pieces dating from the 6th down to the 14th century (new ed. Denbigh, 1870). The MSS. from which he made his selection, running to one hundred volumes,

are deposited in the British Museum. His son, OWEN JONES, born in 1809, made himself a name as an art-decorator. He laid the foundations of his knowledge in an architect's office in London, travelled for four years in southern Europe, and published *Designs for Mosaic and Tessellated Pavements* (1842), *Plans, Elevations, Sections, and Details of the Alhambra* (1845), and *Polychromatic Ornament of Italy* (1845). He was made superintendent of works for the London Exhibition of 1851, and afterwards director of decorations for the Crystal Palace, where he designed the decorations of the Alhambra, Egyptian, Greek, and Roman courts, and wrote guide-books to the first two. In 1853 he published *Principles regulating the Employment of Colour*; in 1856 the *Grammar of Ornament*, still a valuable text-book; in 1864, *One Thousand and One Initial Letters*; and in 1867, *Examples of Chinese Ornament*. He also illustrated several books. He died in London, 19th April 1874.

Jones, PAUL, United States naval commander, by his countrymen styled 'the Pirate,' was born in Kirkcubright parish on the coast of Kirkcubrightshire, 6th July 1747, the fifth and youngest child of John Paul, head-gardener to Mr Craik of Arbigoiland. Apprenticed at twelve as sailor-boy to a Whitehaven merchant, he made several voyages to America, where he had an elder brother settled in Virginia. This brother's property he inherited in 1773, having meanwhile for five years been mate on a slaver; and about the same date he changed his name John Paul for that under which he is famous. He embraced the cause of the American colonies; and when congress in 1775 resolved to fit out a naval force he offered his services. In April 1778, visiting the British coast in a brig of eighteen guns, he performed some most daring exploits, and took advantage of his familiarity with the scenes of his boyhood to make a hostile descent on the shores of the Solway Firth. At Whitehaven he fired one ship and spiked thirty-six guns; from St Mary's Isle he carried off Lord Selkirk's plate, but six years later restored it; and next morning in Belfast Lough he captured the *Drake* sloop-of-war—the first naval success of the Americans. The year after, as commodore of a small French squadron displaying the stars and stripes, he threatened Leith, and on 23d September fought close off Flamborough Head a most desperate and bloody engagement, in which he captured two British men-of-war. Louis XVI. created him a Chevalier of the Order of Military Merit, and congress voted him a gold medal. In 1788 he entered the service of the Empress Catharine, and as rear-admiral of the Black Sea fleet served creditably in the war against Turkey; but a twelvemonth later he quitted the Russian service. He died at Paris, 18th July 1792, his funeral being attended by a deputation of the Legislative Assembly. 'He was,' says Professor Laughton, 'a man of distinguished talent and originality; a thorough seaman, and of the most determined and ferocious courage. On the other hand, his vanity was excessive . . . and his moral character may be summed up in one word—detestable.'

See Lives by Sherbourne (1825), Janette Taylor (1830), Mackenzie (1841), Simms (1845), James Hamilton (1848), J. C. Abbott (1875), and James Barnes (1900); also an article in *Blackwood's Magazine* for October 1887, and J. K. Laughton's *Studies in Naval History* (1887).

Jones, SIR WILLIAM, one of the earliest English orientalists, was born in London, 28th September 1746, the son of William Jones (1680-1749), a learned mathematician and friend of Newton. He had his schooling at Harrow under Thackeray and Sumner, and entered University College, Oxford, in 1764, where his remarkable attainments quickly attracted attention. In 1765 he left

Oxford to become tutor to the eldest son of Earl Spencer, and with him remained five years. He was called to the bar in 1774, and two years later was appointed Commissioner of Bankrupts. In 1770 he published, at the request of the king of Denmark, a *Life of Nadir Shah*, translated into French from the Persian; in 1772 a *Persian Grammar*; in 1774 his Latin Commentaries on Asiatic Poetry; and in 1780 a translation of seven ancient Arabic poems, known as the *Muallakat*, so called from being 'suspended' in the temple at Mecca. In March 1783 he obtained a judgeship in the Supreme Court of Judicature in Bengal, and was knighted. With characteristic ardour he at once devoted himself to the study of Sanskrit with a view to prepare a digest of Hindu and Mohammedan law. He established the Royal Asiatic Society, 'for investigating the history, antiquities, arts, sciences, and literature of Asia,' and was its first president. He contributed largely to the *Asiatic Researches*. Already in 1789 he had finished his translation of *Sarwatida, or the Fatal Ring* (1799), when in 1794 he published a translation of the Ordinances of Manu, a preparatory task for the greater work. Soon after he was attacked with an inflammation of the liver, which carried him off on the 27th April 1794. The East India Company erected a monument to his memory in St Paul's Cathedral, and a statue in Bengal. A collected edition of his works was published by Lord Teignmouth in six quarto volumes in 1799; two supplementary volumes followed in 1801; and a *Life* in 1804. The impulse that Sir William Jones gave to the study of Sanskrit literature was far more important than the performance his short and busy life enabled him to effect. He was indeed a learned scholar, but his scholarship was of the pre-scientific age, and has long since been superseded. But his noble and generous character and his ardent enthusiasm for learning have done much not only to promote learning, but to elevate the character of the scholar.

Jongleurs (Old Fr. *jongleur, juglere*, Ital. *giocolatore*, from the Lat. *jaculator*), among Provençals and northern Frenchmen, a class of minstrels during the middle ages who sang and often composed poems, songs, and fabliaux, and who frequented courts, tournaments, castles, and towns for that purpose. They made a trade of song, poetry, and story-telling, and often of jesting and buffoonery, and are distinct from the knightly poets, the Troubadours and Trouvères. They were often for their special gifts retained in the service of particular lords, and we find them also named indifferently *menestrels* or *menestriers*. Two of their number, Jacques Grise and Hugues-le-Lorrain, founded the church of St Julien in 1331. See Freymond, *Jongleurs and Menestrels* (Halle, 1883).

Jönköping, a town of Sweden, capital of the *len* or county of Jönköping (area, 4468 sq. m.; pop. in 1888, 195,045), stands on a beautiful situation at the southern end of Lake Wetter, 115 miles by rail nearly due E. of Gothenburg. It is famous for its safety-matches. Paper, carpets, tobacco, &c. are also made. Pop. (1875) 13,142; (1890) 19,682. Here several Swedish parliaments have been held, and peace was signed between Sweden and Denmark in 1809.

Jonquil (Fr. *jonquille*, from Lat. *junceus*, 'a rush'), a name given to certain species of *Narcissus* (q.v.) with rush-like leaves. The Common Jonquil (*N. Jonquilla*), a native of the south of Europe, is one of the most common bulbous-rooted plants in our flower-borders. It has from two to six yellow flowers at the summit of its scape (leafless stem). The Sweet-scented Jonquil (*N. odoratus*), also a

native of the south of Europe, is another species very generally cultivated. Perfumed waters are made from Jonquil flowers.

Jonson, BEN, dramatist, was born at Westminster about 1573, a month after the death of his father, who was a minister. His grandfather was of Amundale (probably a member of one of the Johnstone families). Ben was educated at Westminster School under William Camden, whom he held in the highest veneration. He is said to have spent some time at Cambridge, but certainly did not go through the regular academic course. His mother was remarried to a master-bricklayer; and for a while Ben followed the craft of his step-father. As he 'could not endure the occupation' (see his *Conversations with William Drummond of Hawthornden*) he went off to serve as a soldier in the Low Countries, where he distinguished himself by killing one of the enemy in single combat 'in the face of both the camps.' After a short stay abroad he returned and 'betook himself to his wonted studies.' He married early (about 1592) and had children, whom he survived. Among his poems are two tender elegies on the death of his eldest son and eldest daughter. According to his own account his wife was 'a shrew, yet honest.' On one occasion he stayed five years away from her, as the guest of Lord Aubigny.

We first hear of Jonson's connection with the stage in 1597, but he had doubtless been at work for some time previously both as an actor and dramatist. In 1598 he is mentioned by Meres as one of 'our best for Tragedie.' During these early years he seems to have usually collaborated with other playwrights—Porter, Chettle, Dekker, &c. He had a narrow escape in 1598 from the gallows. An actor in Henslowe's company, Gabriel Spence, challenged him to a duel in the fields at Shoreditch. Jonson killed his adversary, was tried for homicide, pleaded his clergy, and escaped with the penalty of branding in the thumb of the left hand and the forfeit of his goods and chattels. In his conversations with William Drummond (q.v.), whom he visited at Hawthornden in 1618-19, he declared that the quarrel was not of his seeking, but that he 'had been appealed to the fields,' adding that the challenger's sword was 10 inches longer than his own. During his imprisonment he was visited by a priest who converted him to the Roman Catholic creed, to which he adhered for the space of twelve years. The fact that he was branded is a recent discovery, made by Mr Cordy Jeaffreson in the course of his researches in the Middlesex Sessions Rolls.

In 1598 *Every Man in his Humour* was produced. There is a tradition that Shakespeare procured this excellent play to be acted; and we know that Shakespeare himself personated one of the characters. In the original version the scene is laid near Florence; afterwards Jonson gave English names to the characters, and shifted the scene to London. *Every Man in his Humour* is the only play of Jonson's which has been revived in modern times. It is lighter and brisker than the elaborate masterpieces of his maturer years. The success of *Every Man in his Humour* inspired *Every Man out of his Humour* (1599), a somewhat tedious play, which was followed by *The Case is Altered* (1599), *Cynthia's Revels* (1600), and *The Poetaster* (1601). In the last play Jonson made a violent attack on Dekker and Marston, and was in consequence assailed in Dekker's *Satiricall*. Subsequently Jonson and Marston were reconciled; they worked together on *Eastward Ho*, in company with Chapman; and Marston dedicated his *Malcontent* to Jonson in handsome terms. But the quarrel broke out again later. *Sejanus*, a solidly constructed but frigid tragedy, was produced in

1603; and *Volpone, or the Fox*, a dexterously ingenious but uncomfortably cynical comedy, in 1605. Of *Epicure, or the Silent Woman* (1609), a farcical mirth-provoking piece, Dryden observed, 'I prefer it before all other plays, I think justly, as I do its author, in judgment, above all other poets.' *The Alchemist* (1610) is the most elaborate and most masterly of Jonson's writings, the magnificent extravagance of Sir Epicure Mammon being depicted with keenest spirit and inexhaustible learning. *Catiline* (1611) is a companion piece to *Sejanus*. *Bartholomew Fair* (1614) hits off the humours of the old London festival with the liveliest gusto, and in the person of Zeal-of-the-Land Busy gives a capital sketch of a canting Puritan elder. *The Devil is an Ass* (1616) and *The Staple of News* (1625) are of smaller account. *The New Inn* (1629-30) was not successful on the stage (as Jonson records in a famous ode); it has an improbable plot, but contains some of the poet's most eloquent writing. The latest comedies were *The Magnetic Lady* (1632) and *A Tale of a Tub* (1633). A delightful pastoral play, *The Sad Shepherd*, was left unfinished.

Ben Jonson's masques are of singular beauty. He was one of the most learned men of his age, and he lavished all the stores of his knowledge on these entertainments; but his sprightliness of fancy and fertility of invention matched his learning, and his masques are models of elegance and grace. The mechanism was provided by Inigo Jones, with whom he frequently quarrelled. Other poets allowed Jones to take the chief credit for the success of their masques; but Jonson insisted that the poetry was the main thing, and that the mechanic's art was of minor importance. Jones finally succeeded (1627) in ousting Jonson from court favour.

In addition to the masques Jonson wrote many elegies, epistles, love-poems, epigrams, and epitaphs. The famous epitaph on the Countess of Pembroke, beginning 'Underneath this sable hearse,' is most happily turned; and another on Salathiel Pavy is hardly inferior. As a song-writer he had few equals. Of his songs the most popular is 'Drink to me only with thine eyes'; but the Hymn to Diana in *Cynthia's Revels*, 'Still to be neat, still to be drest' in *The Silent Woman*, and many of the songs scattered up and down the masques are equally charming. None knew better than Ben Jonson how to write complimentary poems; the best is perhaps the epigram to the Countess of Bedford. 'This morning, timely rapt with holy fire.' To the collected edition (1623) of Shakespeare's works he prefixed a noble memorial poem. His prose *Discourses* are distinguished by admirable judgment and unaffected purity of diction.

When he was in his forty-sixth year he spoke with humorous complacency of his 'mountain belly' and 'rocky face.' But bodily infirmities came in later years. Towards the end of 1625 he was attacked by the palsy, and afterwards by dropsy. For the last two or three years of his life he was unable to leave his room. His sufferings were intensified by poverty; but he found patrons in King Charles and the Earl (afterwards Duke) of Newcastle. He died in August 1637, and was buried at Westminster Abbey. A collection of poems to his memory, by most of the famous wits of the age, was published in 1638 under the title of *Jonsonus Verbaus*. His arrogance and asperity had procured him some enemies; but he had been liberal in his praise of others' merits, and the younger poets regarded him with reverence and affection. The slab over his grave bears the inscription, 'O rare Ben Jonson!' His works were edited (in 9 vols.) in 1816 by William Gifford, who cleared away the baseless calumnies by which his

memory had been assailed. Gifford's edition was re-issued in 1875 (9 vols.), with additional notes by the late Lieut.-col. Cunningham. See A. C. Swinburne, *A Study of Ben Jonson* (1890).

Joppa. See JAFFA.

Jordaens, JAKOB, a Dutch painter, born at Antwerp, 19th May 1593, and admitted into the St Luke guild in 1615. He ranks next to Rubens amongst Flemish painters in the departments they both cultivated. Jordaens' style is marked by realistic fidelity and vigour of portraiture, and his colouring is generally good; but he is sometimes coarse and inelegant. He excelled in humorous pieces depicting Flemish life, and painted also scriptural and mythological subjects. He died at Antwerp, 18th October 1678.

Jordan ('descending'), the principal river of Palestine, the bed of which forms a great valley stretching from north to south, in the eastern part of the country. It is formed by the junction of three streams. The highest source of the Jordan is the Hasbany, which rises near the Druse town of Hasbeiya, on the west-side of Mount Hermon. There is another spring on the south side of the same mountain at Banias (Panaea or Casarea Philippi), and the Leddan at Dan. The Jordan flows south, and after a course of a little over 100 miles, having passed through the small Hulh-Lake (The Waters of Merom) and the Lake of Tiberias (Sea of Galilee), 682 feet below the Mediterranean, it falls into the northern extremity of the Dead Sea (q.v.), 1292 feet below the Mediterranean. Besides smaller affluents, it receives four streams, the Wady Far'ah and Wady Kelt from the west, the Hieromax and Jabbok from the east. McGregor estimates the Jordan to have 200 miles of channel from the Hasbeiya source to the Dead Sea. The source is 1700 feet above the Mediterranean, making a total fall when it reaches the Dead Sea of 3000 feet. The bed of the river varies much in breadth, from 30 to 50 yards, flows latterly in a sunken channel, and its banks of white marl are in some places flat, in others steep; in the north partly occupied by fields of barley, but barren below Jericho. There are upwards of forty fords, but the two at Jericho are impassable when the river is in flood. The course of the Lower Jordan was explored by Lieutenant Molyneux in 1847, by Lieutenant Lynch in 1848; the Upper Jordan for the first time by John McGregor in his Rob Roy canoe in 1869.

Jordan, MRS DOROTHEA, actress, was born near Waterford in 1762, the daughter of an actress and one Bland, whose father afterwards had the marriage annulled. She appeared first in Dublin, under the name of Miss Frances, as Phoebe in *As You Like It*, but soon became popular in romps and 'brooches' parts. Having had a quarrel with her manager, in 1782 she crossed the channel and obtained an engagement from Tate Wilkinson, of the York circuit, with whom she acted for three years. It was Wilkinson who joked her about 'crossing the Jordan,' and so suggested a new name to her; the 'Mrs' was added to secure a legacy—a theatrical wardrobe—left to her on this condition by an aunt who was a stickler for the proprieties. Mrs Jordan made her debut at Drury Lane in *The Country Girl* in October 1785—just seven weeks before Mrs Clive died—and in a few days she had bewitched the town; the benches, formerly empty on the nights when Mrs Siddons was not playing, were now filled, and her joyous, apparently irrepressible laugh—her *swindling* laugh, a friend called it—captivated all hearts. In November she appeared as Viola in *The Twelfth Night*—a performance of which Lamb, long after, wrote with a kind of rapture; and he added, 'Her joyous pats (in which her memory now chiefly lives) in her

youth were outdone by her plaintive ones. Nevertheless, for nearly thirty years, it was in the roles of romps and boys that she mainly kept her hold on the public: in the part of a youthful and tender heroine she was less successful, as her wonderful voice lost its freshness and sweetness. In 1790 commenced her connection with the Duke of Clarence, afterwards William IV., which endured until 1811. That she was faithful to him all this time, in spite of her youthful follies, there is no reason to doubt, and her considerable income was placed freely at his service. As some return he was warmly attached to her, and caused all who came to his house to treat her as his duchess. No satisfactory explanation has ever been given of the sudden breaking-off of their relations: Mrs. Jordan testified to the Duke's generosity, but there is reason to believe she sacrificed herself in the settlements that followed. At anyrate, after playing in London and in the provinces until 1814, she was compelled to retire to France for a debt of £2000 — and this at a time when she was supposed to be in receipt of a pension of £1500 a year, besides her earnings as an actress. She lived in comparative poverty, though not in actual want, at St. Cloud, and died there, friendless and alone, 3d July 1816. In 1831 King William raised her eldest son to the peerage, as Earl of Munster, and gave the other Fitz-Clarences the rank and precedence of the younger sons and daughters of a marquis. See the *Life* by Boaden (2 vols. 1831), and *Temple Bar* (October 1877).

Jornandes, better JORDANIS, historian of the Goths, was by birth a Goth, or of both Alan and Gothic descent, and flourished in the middle of the 6th century. He was first a notary, but afterwards, adopting the Christian religion, became a monk. He wrote two historical works in Latin — *De Regorum ac Temporum Successione*, a dry compendium of history from the creation to 550 A.D., and only valuable for events subsequent to 450 A.D., and *De Gotarum Origine et Rebus Gestis*, which is based on the earlier work (now lost) of the Roman Cassiodorus. This last is our only source of information about much connected with the Goths and other barbarian tribes. The work is, however, a mere compilation, and has many inaccuracies and inconsistencies. Its text is published in Muratori, *Rer. Ital. Script.* vol. i., and in Grotius, *Hist. Gothorum*, &c. (1655).

Jortin, JOHN, miscellaneous writer, was the son of a Huguenot refugee, and was born in London, 23d October 1698, and educated at Charterhouse and Jesus College, Cambridge. Having taken orders, he held in succession the livings of Swavesey in Cambridgeshire (till 1730), Eastwell in Kent, St. Dunstan's-in-the-East, London (from 1751), and Kensington. He was also a prebendary of St. Paul's and archdeacon of London. He died 5th September 1779. At Cambridge he published a volume of meritorious Latin poems, *Lusus Poeticus* (1722). The works for which he was best known are *Miscellaneous Observations upon Authors, Ancient and Modern* (2 vols. 1734-32); *Remarks on Ecclesiastical History* (5 vols. 1751-53); *Life of Erasmus* (2 vols. 1758-60); and *Treats: Philological, Critical, and Miscellaneous*, edited by his son (2 vols. 1790).

Jorullo, a volcanic mountain in the Mexican state of Michoacan, 4315 feet above sea-level, and 1640 feet above the plain on which it stands, is about 150 miles WSW. of Mexico city, in 19° 9' N. lat. and 103° 51' 48" W. long. It was thrown up during one night, 29th September 1759, after several months of subterranean convulsions. The plain on the northern side is inflated like a gigantic bladder, the surface consisting of lava and cinders — a phe-

nomenon to which the people give the name of *malpaquis*: it has an elevation of 40 feet above the rest of the plain, and is convex, rising in the centre to 335 feet. The southern slope of the mountain is covered with luxuriant vegetation from base to summit.

Josaphat. See BARLAAM.

Joseph, the name of four persons in Scripture. (1) JOSEPH, the elder of the two sons of Jacob by Rachel, and his father's favourite among all his sons. His envious brothers sold him into Egypt, where, after he had endured imprisonment in consequence of the calumnious charges of the wife of his master Potiphar, his conduct and skill in the interpretation of dreams brought him the especial favour of Pharaoh and the first place in the kingdom. His prudent foresight enabled him to stave off famine by measures which enormously enhanced the power of the throne, and soon he had the gratification to find his brothers at his feet, driven down into Egypt for lack of bread. The story is told in full detail in Genesis, how at last he made himself known to his trembling brothers, and sent to Canaan for his aged father and the whole family, placing them after their arrival in the land of Goshen. Joseph died at length full of years and honours, and when the Israelites left Egypt they carried with them his bones to be buried in Shechem in the inheritance of his son Ephraim.

(2) JOSEPH, the husband of the Virgin Mary, and reputed father of Jesus, a carpenter at Nazareth. The earliest genealogy of Jesus makes Joseph a descendant of David, and would seem to favour the natural birth of Jesus from parents both of royal line; but the notion of the miraculous conception is found in both Matthew and Luke, and was early accepted as a part of Christian belief. Later days developed the idea of the perpetual virginity of Mary, and made Joseph into her protector and merely nominal husband, giving him eighty years and a grown-up family of sons by a former wife at the time of his formal espousal of Mary. These stories first occur in the apocryphal gospels, earliest of which is apparently the *Prot-evangelium of James*, a 2d-century production quoted by Origen, and mentioned by Clement of Alexandria and Justin Martyr. The apocryphal *Historia Josephi fabri lignarii*, which now exists in Arabic, is thought by Tischendorf to have been originally written in Coptic. Joseph appears last in the gospel history when Jesus is twelve years old (Luke, ii. 43): he is never mentioned during his ministry, and may be assumed to have been already dead. The controversy about the 'brethren of the Lord' has engaged the attention of many writers from the time of St. Jerome to the present day. The main facts related of them in Scripture itself are their unbelief during the lifetime of the Lord, their distinctness from the Twelve (Acts, i. 13; 1 Cor. ix. 5), and their connection with Joseph and Mary. The two opinions that prevailed until the time of St. Jerome about the close of the 4th century were (1) that they were sons of Joseph by a former wife, as held by most orthodox Christians, and by such Fathers as Clement of Alexandria, Origen, Eusebius, Gregory of Nyssa, Epiphanius, Ambrose, and the later Greek writers; (2) that they were sons of both Joseph and Mary, as maintained by Tertullian, Helvidius, Bonosus, and the heretical Arabian sect of the Antidicomarianites, and Alford and Ferrar among modern scholars. St. Jerome about the year 383 wrote a treatise in answer to Helvidius, maintaining that they were cousins after the flesh, being sons of Mary, the wife of Alphæus (identical with Clopas) and sister of the Virgin. In this opinion Jerome was followed by Pelagius, Augustine, Theodoret, and later Latin

writers. But as Bishop Lightfoot points out in the Dissertation, 'The Brethren of the Lord,' appended to his Commentary on the Epistle to the Galatians (1865), Jerome claims no traditional support for his theory, and does not himself hold it staunchly and consistently. The strongest objection against the Helvidian theory is that Jesus on the cross commended his mother to the keeping of St John (John, xix. 26, 27); against the Hieronymian, that it gives a special sense to 'brethren' unsupported by biblical usage, and that it supposes two if not three of the unbelieving 'Lord's brethren' to be in the number of the Twelve. Lightfoot favours the Epiphonian as traversing less serious scriptural difficulties, and more in accordance with Christian tradition.

(3) **JOSEPH OF ARIMATHEA**, a rich Israelite of high character, who seems to have been a member of the Great Council or Sanhedrim. He opposed the determination of his colleagues to bring about the death of Jesus, but did not openly profess himself a disciple from motives of fear. But the courage of his convictions came to him at the moment of the crucifixion, and on the evening of that day he went boldly to Pilate and begged the body of Jesus, burying it reverently in his own rock-hewn tomb. An ancient tradition makes him carry the Grail (q.v.) to Britain about the year 63 and settle at Glastonbury (q.v.).

(4) **JOSEPH**, called Barsabas and surnamed Justus, one of the two persons chosen as worthy to fill the vacant place of Judas among the Twelve (Acts, i. 23). Papias relates a tradition that he had been miraculously preserved by the Lord from the fatal effects of a cup of poison he had drunk.

Joseph I., emperor of Germany, the eldest son of Leopold I., born at Vienna, 26th July 1678, was crowned king of Hungary in 1689, and king of the Romans in 1690, became emperor in 1705, and died on 17th April 1711. Holding opinions more liberal than those which have generally prevailed in his family, he granted privileges to the Protestants of his dominions, especially in Silesia. In alliance with Britain, he prosecuted actively and successfully the war of the Spanish succession against France. Another favourite scheme of his was the appropriation of Bavaria.

Joseph II., emperor of Germany, son of Francis I. and Maria Theresa (q.v.), was born 13th March 1741. He early gave proof of excellent abilities. In 1764 he was elected king of the Romans, and after the death of his father (1765) emperor of Germany; but until the death of his mother in 1780 his actual share of power amounted to little more than the chief command of the army and the direction of foreign affairs. Although he failed in his object of adding Bavaria to the Austrian dominions (1777-79 and again in 1785), which he hoped to obtain in exchange for the Low Countries, he acquired Galicia, Lodomeria, and the county of Zips, at the first partition of Poland in 1772; and in 1780 he appropriated great part of the bishoprics of Passau and Salzburg. He was a zealous reformer; but having imbibed, like Frederick the Great, the principles of absolute rule which prevailed in that age, he attempted his reforms too rashly, and too much by the exercise of mere authority. As soon as he found himself in full possession of the government of Austria he proceeded to declare himself independent of the pope, and to prohibit the publication of any new papal bulls in his dominions without his *placet*. The continued publication of the bulls 'Unigenitus' and 'In Cœna Domini' was prohibited. Besides this, he suppressed no fewer than 700 convents, reduced the number of the regular clergy from 63,000 to 27,000, prohibited papal dispensations as to marriage, and on 15th October

1781 published the celebrated Edict of Toleration, by which he allowed the free exercise of their religion to the Protestants and Non-united Greeks in his dominions. Pope Pius VI. thought to check this course by a personal interview with the emperor, and for that purpose made a visit to Vienna in 1782, but was unsuccessful in his object. Joseph's other important reforms were the abolition of serfdom and the reorganisation of the system of taxation on a juster basis. He also curtailed the feudal privileges of the nobles. In 1788 he engaged in a war with Turkey, in which he was unsuccessful; and the vexation caused by this, and by the revolts in his own dominions, in Hungary, Tyrol, and the Netherlands, and the necessity under which he felt himself of revoking many of the edicts by which he had sought to promote the welfare of his people, especially in Hungary, hastened his death, which took place on 20th February 1790. He founded many valuable educational and scientific institutions, and did much to promote the progress of arts, manufactures, and commerce in Austria.

See works by Brunner (1868-85), Lustkandl (1881), and Nosinich and Wiener (1885); also Léger's *History of Austro-Hungary* (Eng. trans. 1890).

Joseph, king of Naples. See BONAPARTE.

Joséphine, MARIE ROSE, empress of the French, was born 23d June 1763, in the island of Martinique, where her father, Tascher de la Pagerie, was captain of the port at St Pierre. She had only an indifferent colonial education; but her qualities of mind and heart, even more than her beauty, won universal regard. When about fifteen years of age she came to France, and in 1779 married Viscount Alexandre Beauharnais (q.v.). A daughter of this marriage, Hortense, queen of Holland, was the mother of the Emperor Napoleon III. Joséphine's husband was executed during the Reign of Terror, she herself just escaping. On 9th March 1796 she was married to Napoleon Bonaparte. She accompanied him in his Italian campaign, and exercised a great influence in restraining him from measures of violence and severity. At Malmaison, and afterwards at the Luxembourg and the Tuileries, she attracted round her the most brilliant society of France, and contributed not a little to the establishment of her husband's power. But her marriage with Napoleon proving unfruitful, it was dissolved by law on 16th December 1809. Joséphine retained the title of empress, corresponded with Bonaparte, and, if the allied sovereigns had permitted it, would have rejoined him after his fall. She died at Malmaison, 29th May 1814.

See Aubenas, *Histoire de Joséphine* (1859); *Mémoires de Madame de Réaumont* (2 vols. Paris, 1879-80; Eng. trans. 1880); and two sumptuous French works on Joséphine by F. Masson (1808-09).

Josephstadt, one of the most important fortresses of the Austrian empire, stands at the confluence of the Mettau and the Elbe in Bohemia, 10½ miles N. by E. of Koniggratz. Pop. 5063, of whom 3500 belong to the garrison.

Josephus, FLAVIUS, a celebrated Jewish historian, was born at Jerusalem in 37 A.D. He was of both royal and sacerdotal lineage, being descended, on the mother's side, from the line of Asmonean princes, while his father, Matthias, officiated as a priest in the first of the twenty-four courses. The careful education he received developed his brilliant faculties at an unusually early age, and his acquirements both in Hebrew and Greek literature soon drew public attention upon him. Having successively attended the lectures at the paramount religious schools of his time—sects, as he inaccurately terms them—he withdrew into the desert to sit at the feet of

one Banos, who is conjectured to have been either a follower of John the Baptist or an Essene. Three years later he returned to Jerusalem, and henceforth belonged to the body of the 'Pharisees,' which in fact comprised the bulk of the people. So highly was his ability esteemed that at the age of only twenty-six he was chosen delegate to Nero. When the Jews rose in their last and fatal insurrection against the Romans Josephus was appointed governor of Galilee. Here he displayed the greatest valour and prudence; but the advance of the Roman general Vespasian (67 A.D.) made resistance hopeless. The city of Jotapata into which Josephus had thrown himself was taken after a desperate resistance of forty-seven days. Along with some others he concealed himself in a cavern, but his hiding-place was discovered, and being brought before Vespasian he would have been sent to Nero had he not—according to his own account, for Josephus is his own and his sole biographer—promised that his captor would yet become emperor of Rome. Nevertheless he was kept in a sort of easy imprisonment for about three years. Josephus was present in the Roman army at the siege of Jerusalem by Titus; and after the fall of the city (70 A.D.) was instrumental in saving the lives of some of his relatives. After this he appears to have resided at Rome, and to have devoted himself to literary studies. The exact period of his death is not ascertained. All we know is that he survived Agrippa II., who died 97 A.D. He was thrice married, and had children by his second and third wives. His works are the *History of the Jewish War*, in 7 books, written both in Hebrew and Greek (the Hebrew version is no longer extant); *Jewish Antiquities*, in 20 books, containing the history of his countrymen from the earliest times down to the end of the reign of Nero (the fictitious Hebrew *Josippon*, which for a long time was identified with Josephus' *Antiquities*, dates from the 10th century A.D.); a treatise on the *Antiquity of the Jews*, against Apion, in 2 vols., valuable chiefly for its extracts from old historical writers; and an *Autobiography* (37-90 A.D.), in one book, which may be considered supplementary to the *Antiquities*. The other works attributed to him are not believed to be genuine.

The peculiar character of Josephus is not difficult to describe. He was in the main honest and veracious; he had a sincere liking for his countrymen, and rather more pride and enthusiasm in the old national history than he could well justify; but the hopelessness of attempting to withstand the enormous power of the Romans and an aversion to martyrdom caused him to make his terms with the enemy, perhaps in the faint hope of being thus of some use to the national cause. The influence of Greek philosophy and learning is visible in all his writings, and has given to his conception of biblical history a somewhat rationalistic tinge. He speaks of Moses as a human rather than a divinely inspired lawgiver; he doubts the miracle in the crossing of the Red Sea, the swallowing of Jonah by the whale, and, generally speaking, whatever is calculated to teach that there was a special miraculous Providence at work on behalf of the chosen people. The famous passage about Jesus is generally conceded to be an interpolation. His style is easy and elegant, and Josephus has often been called the Greek Livy.

The *editio princeps* of the Greek text appeared at Basel (Froben) in 1544. Since then the most important editions (with notes) are those of Hudson (Oxford, 1720), Havercamp (Amst. 1726), Dindorf (Paris, 1845-47), Bekker (6 vols. Leip. 1855-56), and Niese (Berlin, 1886 *et seq.*). Josephus has been frequently translated; the most celebrated versions in English have been those by

L'Estrange (1702), Whiston (1737; new and revised edition by Sbilleto, 5 vols. 1889-90), Maynard (1800), and Traill and Taylor (1851). See the German books devoted to Josephus by Barwald (1877), Böttger (1879), Bloch (1879), Destimon (1882), and Olitzki (1886).

Joshua (Heb. *Jehōshua*; Gr. *Iōsons*, from late Heb. *Jēshua*), or HOSHĒA (Num. xiii. 16), the son of Nun, of the tribe of Ephraim, is first mentioned in Ex. xvii. 9 as commanding the warriors of Israel in the battle of Rephidim. He was also one of the twelve spies sent out from Kadesh to collect information about the strength of the Canaanites and the prospects of the intended invasion (Num. xiii.), and when the others returned disheartened he and Caleb alone retained their courage and reported in favour of an armed advance. These two alone, therefore, out of all the grown men of Israel, were exempted from the divine sentence that because of their want of faith they should fall in the wilderness. During the forty years' wanderings Joshua acted as the 'minister' or personal attendant of Moses (Ex. xxiv. 13, &c.), a relation which seems to have marked him out as the favourite disciple and probable successor of the lawgiver. After 'the Lord was angry with Moses' Joshua was expressly designated to lead the people into Canaan (Deut. i. 38), and this designation was solemnly confirmed at the tabernacle (Deut. xxxi. 14 *seq.*) before Moses' death. The book that bears his name is a narrative of the conquest and settlement of Canaan under the leadership to which he thus succeeded. It relates with considerable detail the passage of the Jordan, the fall of Jericho and Ai, the submission of the Gibeonites, the defeat of the five kings of the south at Beth-horon and of the four kings of the north at the waters of Merom, gives a large number of geographical and administrative details as to the distribution of the conquered territory among the tribes that had taken part in the conquest, and concludes with two addresses which Joshua delivered shortly before his death. The Jewish rabbins and early Christian writers all supposed this book to have been written by Joshua himself; but this is an impossible assumption, for besides telling of his death it alludes to a number of things that did not happen until long after that event (see, for example, xv. 63 compared with Judges, xix. 10-12; and xix. 47 with Judges, xviii. 7, 27 *seq.*). In fact, like the other historical books of the Old Testament, it is an anonymous writing, and when critically examined is seen to have been originally united to the Pentateuch, and to have been composed in the same manner. It is made up of extracts from various narratives, pieced together by a later hand in the manner of eastern historians, and in its present form cannot be much earlier than the time of Ezra. Most modern critics are agreed that the documents used by the editor were mainly three—the Jehovistic (known to critics by the symbol JE) of the 8th or 9th century, the Deuteronomistic (D) of the 7th, and the Priestly (P) of the 5th. To the Jehovistic document belong in the main chaps. ii. 1-viii. 29; ix. 1-xi. 9; xxiii., xxiv., and a few short fragments in other chapters. To the Deuteronomist are assigned chaps. i., viii. 30-35; xi. 10-xiii. 14; xiv. 6-15, and some other small portions; while the remainder, including the greater part of the account of the division of the territory, comes from the priestly writer. Its geographical details are characterised by great vagueness, except as regards the portion of the land which was held by Jews after the exile. The best commentary on Joshua is that of Billmann (1886).

Josiah, one of the kings of Judah, was the son of Amon and Jedidah, and succeeded his father at the age of eight in 641 B.C. He grew up an ardent religious reformer, and purged Judah and

Jerusalem from idolatry. It was in his reign that Hilkiah the high-priest is said to have discovered the 'Book of the Torah,' by which some understand Deuteronomy, others Exodus, and others again the whole Pentateuch. The king now vigorously re-established the worship of Jehovah, and instituted the rites in the newly-discovered book. He met his death at Megiddo, in the valley of Esdraelon, when attempting to check the advance of Pharaoh-Necho against the Assyrians, 609 B.C. Josiah was the last of the good kings of Judah. In his days prophesied Jeremiah and Zephaniah.

Josika. See HUNGARY (*Literature*).

Jost, ISAAK MARKUS, a Jewish historian, was born at Bernburg in Anhalt, 22d February 1793. He laboured as a Jewish schoolmaster at Berlin (1826-35) and Frankfort-on-Main (1835-60), and died at Frankfort, 20th November 1860. He wrote *Geschichte der Israeliten* (9 vols. 1829-29), to which were added *Neuere Geschichte der Israeliten, 1815-45* (3 vols. 1846-47), and *Geschichte des Judenthums* (3 vols. 1857-59). He also edited a German translation of the *Mishnah*, with text and commentary (6 vols. 1832-34).

Jotunheim. See GIANTS.

Joubert, GENERAL. See TRANSVAAL.

Joubert, JOSEPH, was born at Montignac in Périgord, 6th May 1754, and studied and taught till twenty-two at the college of Toulouse, then under the direction of the Fathers of the Christian Doctrine. He then went to Paris, and here made the acquaintance of Diderot, D'Alembert, Marmontel, and La Harpe, and lived through all the fever of the Revolution. He became the bosom friend of Fontanes and Chateaubriand, and he carried both to the famous *salon* of Madame de Beaumont. In 1790 his native townsmen elected him as justice of the peace, and in 1809 he was nominated by Napoleon on the recommendation of Fontanes to a seat in the council of the new university. At Villeneuve and at Paris he lived henceforward, and his years glided quietly away, while he read, dreamed, walked, wrote letters, and discoursed to friends who thronged even to his bedroom, which he seldom left before three o'clock in the afternoon. Despite weak health, he carried his head high all his life, and never ceased to read and re-read his favourite books, and jot down his meditations. Yet he published nothing in his life, although he was the keenest as well as the kindest critic to the writings of all his friends. He died 4th May 1824. Fourteen years after, his widow acceded to the prayers of her friends to allow a small volume to be printed from his papers. Chateaubriand edited it; Sainte-Beuve praised it without stint in the *Revue des Deux Mondes*, and Joubert's fame was from the moment of its appearance assured. And his *Pensées*, alike from their intrinsic value and insight and their faultless form, are worthy of their place in the splendid succession of La Rochefoucauld, Pascal, La Bruyere, and Vauvenargues.

At length in 1842 Joubert's nephew, Paul de Raynal, issued an adequate edition of the *Pensées et Maximes* from the more than 200 small manuscript books, with the addition of a number of letters, and an admirable biographical sketch. Another and enlarged edition by his brother, Arnaud Joubert, followed in 1850; yet another, better arranged, by Louis de Raynal in two volumes in 1862. There are translations by G. H. Colver (Boston, 1867) and Henry Attwell (1877). See Sainte-Beuve's *Causeries du Lundi* (vol. 1), *Portraits Littéraires* (vol. ii), and almost every page of his *Chateaubriand et son Groupe*; also Matthew Arnold's *Essays in Criticism* (1865).

Jouffroy, THEODORE SIMON, a French philosopher, was born at Pontets, a village of the Jura, on

7th July 1796. He became a pupil of Cousin, the philosopher, at Paris, and from 1817 onwards taught philosophy at various educational institutions in Paris. Ill-health obliged him in 1838 to exchange his professorial chair for the post of librarian to the university. He died at Paris, 4th February 1842. Jouffroy was not an original thinker, and founded no school. His merit is that he was the lucid interpreter of the teaching of the Scottish philosophers Reid and Dugald Stewart; he translated their works, with critical introductions and notes. His own best books were *Mélanges Philosophiques* (1833; new ed. 1883), *Cours du Droit Naturel* (1835), and *Cours d'Esthétique* (1843; new ed. 1883). A prominent feature of his teaching was the sharp separation of psychology from physiology. For some time Jouffroy was an industrious member of the Chamber of Deputies; he was also well known as a journalist. See Life by Tissot (1876).

Jouffroy d'Abbans, CLAUDE, MARQUIS DE (1751-1832), claimed by the French as the inventor of steam-navigation, served in the army, and did in 1783 make a small paddle-wheel steamboat sail up the Rhone at Lyons—the connection between piston and paddle-wheel axle being rack-and-pinion. Compelled to emigrate by the Revolution, he failed, on account of financial ruin, to float a company till after Fulton had made his successful experiments on the Seine in 1803. See the article SHIPBUILDING; and a monograph on him by J. C. A. Prost (Paris, 1889).

Jongs, JUGGS, or *Joggs*, the name given in Scotland to a form of pillory which was used also in Holland and probably in other countries. The jongs were nothing more than an iron ring or collar, fastened by a chain of two or three links to a pillar or wall in some public place, such as a market-cross, a market tron or weighing post, a prison door, a church door, a churchyard gate, a churchyard tree, a tree beneath whose branches courts were held, and the like. The ring or collar opened by a hinge or joint, so as to enclose the culprit's neck, when it was secured by a loop or staple and a padlock. The jongs were employed as a punishment as well for ecclesiastical as for civil offences. They may be traced as far back as the 16th century, and, although they have not been in use for the last hundred years, they may still be found hanging at a few country churches. The accompanying wood-cut represents the jongs at the churchyard gate of the picturesque village of Duddingston, 2 miles SE. of Edinburgh. The Branks (q.v.) were occasionally hung on the same pillar with the jongs.



Jongs.

Joule, JAMES PRESCOTT, F.R.S., LL.D., one of the most distinguished experimental philosophers, was born 24th December 1818 at Salford. In his youth he had the good fortune to have for instructor in science the celebrated Dalton; and he soon showed, by constructing for himself electrical machines and other philosophical instruments, the bent of his genius. His earliest notable experiments were made with reference to electro-magnetic engines; from which he passed to quantitative

determinations regarding heat, and the transformation of various forms of Energy (q.v.). He is justly entitled to be considered as the experimental founder of the modern theory of conservation of energy—the greatest generalisation ever made in physical science. In 1878 a civil list pension of £200 was conferred upon him. He died 11th October 1889, at Sale, near Manchester. See *Nature* (October 1882); his collected papers (published by the Physical Society, 1884-87); and the *Memoir* by Osborne Reynolds (1893).—The name *Joule* has been suggested, and to some extent used, for the unit of work in practical electricity. It is the work done in one second by the *ampere* or unit current flowing through the *ohm* or unit resistance, and is therefore, according to Joule's Law (see ELECTRICITY), the heat developed in one second in a conductor having that resistance and carrying that current. It is approximately equal to 10,000,000 ergs; so that 'Joule's Equivalent,' defined as the mechanical equivalent of the heat required to raise the temperature of one gramme of water from 0° C. to 1° C., contains to the same approximation 4.16 *joules*.

Jourdan, JEAN BAPTISTE, COMTE, a French marshal, born 29th April 1762, at Limoges. He entered the army at sixteen, and, after seeing service in North America, rose under the Republic to the rank of a general of division. In September 1793 he obtained the command of the Army of the North, and on 16th October defeated the Austrians at Wattignies. In 1794 and 1795 he commanded the Army of the Meuse and Sambre, and with it gained the victory of Fleurus (26th June 1794), drove the Austrians back across the Rhine, took Luxemburg, and laid siege to Mainz. But on 11th October 1795 he was defeated at Höchst, and thus compelled to retreat over the Rhine. Crossing this river again in 1796, he penetrated as far as Bavaria, but was there beaten by the Archduke Charles at Amberg and Würzburg; this discomfiture made him resign his command. In 1799 the Directory entrusted him with the command of the Army of the Danube; but he was again defeated by the Archduke Charles at Ostrach and at Stockach. Although he took no part in the *camp d'Italie* of 18th Brumaire, the First Consul employed him in 1800 in the reorganisation and administration of Piedmont; and on the establishment of the Empire in 1804 he was made a marshal and a member of the Council of State. In 1806 he was nominated governor of Naples, and afterwards accompanied King Joseph Napoleon to Spain as chief of his staff. Louis XVIII. made him a count in 1819. But his republican principles led him to enter heartily into the revolution of 1830. He died at Paris, 23d November 1833.

Journalism. See NEWSPAPERS.

Joust. See TOURNAMENT.

Jove. See JUPITER.

Jowett, BENJAMIN, the translator of Plato, was born at Camberwell in 1817, and educated at St Paul's School and Balliol College, Oxford, where he had a distinguished career, taking the Hertford scholarship in 1837, a classical first-class in 1839, and the Latin essay in 1841. Already a Fellow in 1838, he was tutor of his college from 1840 till his election as master in 1870. Thus his whole life had been identified with Balliol, and as master his influence is supposed to have permeated the college to a degree almost unexampled. He was a member with Macaulay of the Commission for inquiry into the mode of admission to the Indian Civil Service, and he was appointed in 1855 to the regius professorship of Greek at Oxford. He received the degree of Doctor from Leyden in 1875, Edinburgh in 1884, and Cambridge in 1890, and acted as vice-chancellor

from 1882 till 1886. His theological writings are an article 'On the Interpretation of Scripture' in *Essays and Reviews* (1860), for the alleged heresies in which he was tried but acquitted by the vice-chancellor's court; and a *Commentary on the Epistles of St Paul to the Thessalonians, Galatians, and Romans* (2 vols. 1855); and his *College Sermons* (1895). He is best known by his translation of the *Dialogues* of Plato (4 vols. 1871; 2d ed. 5 vols. 1876), with its admirably learned and lucid introductions, and his less happy versions of Thucydides (2 vols. 1881) and the *Politics* of Aristotle (1885). He died 1st October 1893.

See the *Life and Letters* by E. Abbott and L. Campbell (1897-99), and a sketch by Lionel Tollemache (1895).

Joyce's Country. See GALWAY.

Juan. See DON JUAN, JOHN OF AUSTRIA.

Juan Fernandez, called also MAN-A-TIERRA ('nearer the mainland'), a rocky island in the Pacific Ocean, 420 miles W. of Valparaiso, Chili, to which it belongs. It is 13 miles long and 4 broad, and is for the most part a series of rocky peaks of volcanic origin, the highest of which, Yunque, is 3000 feet above sea-level. The trees are mostly ferns. The sandalwood trees are nearly all exterminated. Horses, pigs, and goats run wild. The island was discovered by the Spaniard whose name it bears in 1563, and was frequently visited by buccaneers down to its occupation by the Spaniards in 1750. Here Alexander Selkirk, a buccaner, a native of the Scotch fishing-village of Largo, lived in solitude from 1704 to 1709. His story is supposed to have suggested the *Robinson Crusoe* of Defoe; though it should be remembered that Robinson's island was on the other side of South America, near the mouth of the Orinoco. When Spain lost her South American colonies Juan Fernandez fell to Chili, which used it as a penal settlement from 1819 to 1835. It is usually inhabited by a few Chilean seal and sea-lion hunters; and in 1877 it was leased by the Chilean government to a Swiss, who established a small colony there. See an article in *Chambers's Journal* (1888); and Mackenna, *Juan Fernandez* (Santiago, 1883).

Juarez, BENITO, president of Mexico, was born of Indian parents in Oaxaca in 1806, became an advocate, and as governor of his native state (1847-52) was distinguished both for his ability and his honesty. Exiled during the dictatorship of Santa-Anna, he returned when the republic was restored, and in 1857 was elected president of the Supreme Court (equivalent to vice-president of the nation). On the overthrow of the Liberal president by the clerical party in 1858 Juarez assumed the executive, but was compelled to retire to Vera Cruz, where his government was recognised by the United States in 1859, and whence he issued decrees abolishing religious orders and confiscating church property. In January 1861 he was able to enter the capital, and in March was elected president for four years. In December of the same year the allied forces of England, France, and Spain occupied Vera Cruz (see MEXICO); in April the British and Spanish withdrew, but the French remained, and declared war against Juarez, who retreated gradually to the northern frontier, and remained for nearly a year at El Paso del Norte. He entered Mexico city again in July 1867, Maximilian (q.v.) having been shot meanwhile by order of court-martial an ungenerous but not impolitic. Juarez was again elected president for four years, years disturbed by repeated revolutionary attempts. In 1871 he was re-elected, and the risings became even fiercer and more frequent; but he faced all his foes with the dogged courage of his race, and was holding his position with unwearied energy

when he died, somewhat suddenly, 18th July 1872. See the *Life* by Ulick R. Burke (1894).

Juba, a great river of eastern Africa, which flows into the Indian Ocean at about 0° 5' S. lat., and whose mouth marks the northern boundary of the coast placed under British control by the agreement with Germany in 1890. The river has been explored to beyond 3° N. lat., and Cecchi identifies the Umo as its upper waters; so that it probably takes its rise in the same mountains as the feeders of the Nile.

Juba. See NUMIDIA.

Jubal, son of Lamech and Adah in the Genesis story, the inventor of the harp and organ, probably general terms for stringed and wind instruments. The meaning of the name is most likely significant, connected with *yobel*, 'jubilee.'

Jubulpore. See JABALPUR.

Jubilate, the 100th Psalm, which in the Vulgate begins *Jubilate Deo omnis terra*. It was added to the English Prayer-book in 1552, to be sung after the Second Lesson, instead of the *Benedictus*, when that canticle occurs in the chapter for the day; but it is used at other times as well, and always at thanksgivings.

Jubilee, THE YEAR OF (Heb. *yobel*), a peculiar theocratic, and apparently theoretical much more than practical, institution among the Hebrews (Leviticus, xxv.), by which, every fiftieth (not forty-ninth) year, the land that in the interval had passed out of the possession of those to whom it originally belonged was restored to them, and all who had been reduced to poverty, and obliged to hire themselves out as servants, were released from their bondage; while at the same time all debts were remitted (Jos. *Ant.* iii. 12). The jubilee forms, as it were, an exalted Sabbatical Year (q.v.), and the land was completely to be left to rest in the former as in the latter. The design of this institution was chiefly to prevent the growth of an oligarchy of land-owners, and the total impoverishment of some families. It was proclaimed at the end of the harvest-time, like the sabbatical year, on the day of atonement, by the 'yobel' (a kind of horn), hence probably also its name. There is no trace in the whole history of the Hebrews down to the Babylonian exile that the jubilee had ever been observed; after the return, however, it appears to have been rigorously kept, like the sabbatical year, for some time at least; but, from its general impracticability, it must soon have fallen into dis-use. Dillmann maintains the 'year of liberty' of Ezek. xlvi. 16-18 to be the year of jubilee, while Kuenen and Wellhausen make it the sabbatical year.

The Christian church adopted the term *Jubilee* from the Jewish, and the jubilee in two forms, the 'ordinary' and 'extraordinary,' is still an institution in the Roman Catholic Church, as a period of remission from the penal consequences of sin. The ordinary jubilee is that which is celebrated at stated intervals, the length of which has varied at different times. Its origin is traced to Pope Boniface VIII., who issued, for the year 1300, a bull granting a plenary indulgence to all pilgrim-visitors of Rome during that year, on condition of their penitently confessing their sins, and visiting the church of St Peter and St Paul, fifteen times if strangers, and thirty times if residents of the city. Innumerable troops of pilgrims from every part of the church flocked to Rome. As instituted by Boniface, the jubilee was to have been held every hundredth year. Clement VI., in a bull of 1343, abridged the time to fifty years. The number of pilgrims that year is said to have been no fewer than 1,000,000! The term of interval was still further abridged by Urban

VI., and again by Paul II., who in 1470 ordered that thenceforward each twenty-fifth year should be held as jubilee—an arrangement which has continued ever since to regulate the ordinary jubilee. Paul II. extended still more, in another way, the spiritual advantages of the jubilee, by dispensing with the personal pilgrimage to Rome, and granting the indulgence to all who should visit any church in their own country designated for the purpose, and should, if their means permitted, contribute a sum towards the expenses of the Holy Wars. The substitution by Leo X. of the fund for building St Peter's Church for that of the Holy War, and the abusive and scandalous proceedings of many of those appointed to preach the Indulgence (q.v.), were among the proximate causes of the Reformation. In later jubilee years the pilgrimages to Rome gradually diminished in frequency, the indulgence being, for the most part, obtained by the performance of the prescribed works at home; but the observance itself has been punctually maintained at each recurring period, with the single exception of the year 1800, in which, owing to the vacancy of the holy see, and the troubles of the times, it was not held.

The extraordinary jubilee is ordered by the pope out of the regular period, either on his accession, or on some occasion of public calamity, or in some critical condition of the fortunes of the church; one of the conditions for obtaining the indulgence in such cases being the recitation of certain stated prayers for the particular necessity in which the jubilee originated.

Jubilee is also used for the celebration of a fiftieth anniversary—as the jubilee of George III.'s accession (1809), and of Queen Victoria's (1857); and for festivals generally, as the 'Peace Jubilees' celebrated at Boston, United States, in 1869 and 1872.

Juby, CAPE, on the west coast of Africa, 100 miles south of the frontier of Morocco, with an anchorage. A trading settlement of an English company was established in 1879-89.

Judaea. See PALESTINE.

Judah (Heb. *Yehuda*, 'the Bepraised One') was the fourth son of Jacob and Leah, and founder of the greatest and most numerous of the twelve tribes, to which belonged the royal house of David. In the march through the wilderness it had the van assigned to it; and tradition narrates that its standard was a lion's whelp, with the words: 'Arise, O Lord, and let thine enemies be scattered!' After the conquest of Canaan its territories stretched from the Dead Sea on the east to the Mediterranean on the west (though the Philistines long held possession of the fertile district west of the mountains of Judah), and from Jerusalem (excluding that city) on the north to the land of the Amalekites on the south. The capital of the tribe was Hebron. For its history, see ISRAEL.

Judaisers. See EBIONITES.

Judas, the betrayer of Jesus, surnamed Iscariot, most probably a native of Kerioth in the tribe of Judah, and, if so, the only southerner among the twelve disciples. He must at first at least have been fired with real faith and zeal, for there was no worldly reward to gain when he first left his old life to obey the call of the new prophet of Nazareth. He acted as steward to the company on their journeys, and John tells us that he was covetous and dishonest from the beginning. It was the temptation of money, according to Matthew and Mark, that made him betray his master to the chief priests for thirty pieces of silver. Luke gives the additional motive that Satan had entered into him. The Synoptics represent Jesus as conscious of the meditated treachery, which, moreover, was plainly

foretold by himself, and even prophesied in the Old Testament; John makes Jesus himself hasten it forward (xiii. 27). Whatever sudden or long-premeditated temptation it was that turned the head of Judas, he had not wholly lost moral sentiment, for when he saw the awful consequences of his guilt he was filled with the remorseful horror of despair, and had the grace to go and hang himself. The two variant accounts of his end in Matthew (xxvii. 3-10) and Acts (i. 16-20) have this much in common, and moreover that the blood-money was exchanged for a piece of ground which bore before or after the ill-omened name of *Aceldama*, or the Field of Blood.

The mere desire for gold can hardly be accepted as a motive adequate enough for a crime so monstrous, which has made its perpetrator's name to all time a synonym for shameful treachery. Yet it is almost as hard to find it in the promptings of disappointed ambition, vindictive hatred, or revenge. Theophylact, the elder Lightfoot, Bahrdt, Niemeyer, and Schmidt sought to explain the treachery by a belief in the miraculous powers of Jesus, which would necessarily protect him from the consummation of any deed of violence. The ancient Gnostics, and Noack among moderns, credited Judas with a desire to bring about the redemptive death of Jesus and the consequent triumph of Christian truth. Again Paulus, Winer, Hase, G. Schollmeyer, and Whately believed that the worldly-minded and ambitious Judas had become impatient of the delay in the establishment of the earthly kingdom, and that he adopted his policy with a view to drive Jesus to action by forcing his hand. Keim's explanation is that the force of old associations may have overcome his wavering belief in the Messiahship of Jesus during the excitement of the festival, when a burning mental struggle burst out in his heart under the immediate influence of relatives ardently devoted, as he himself once was, to the old religion associated with the sanctuary of Israel. The old legal and pietistic prepossessions of his materialistic rather than spiritual temperament glowed up anew within his heart, and hurried him without deliberation to a course, the quick reaction from which was hopeless remorse, horror, and despair. Perhaps none of these explanations throw much light upon an enigma so dark as the motives that drove Judas to his fatal treachery, and it may be doubted if these motives were any less obscure and confused than the motives that sway the human heart usually are. Had his avarice been so deep-seated he would never have had any measure of the grace of the disciple, for surely Jesus must have seen the possibilities of good as well as evil in the young disciple whom he attached to himself. But, spite of outward and at first genuine enough enthusiasm, carnal selfishness was deeply rooted in his nature, and when the manifestation of Christ ceased to be attractive to him, as Neander says, it became repulsive, and more and more so every day. The immediate occasion which turned his last remnants of affection into violent hatred may well have been some sharp reproof, some fancied slight or estrangement that came suddenly, and hurried his hot heart to action which, when too late, he was bitterly to repent.

The treachery of Judas has given rise to a long series of psychological studies which are conveniently enumerated in Winer's *Biblisches Realwörterbuch* (3d ed. 1847-48). In Daub's *Judas Ischariote* (1816-18) a short preliminary investigation of the crime opens up a discussion of evil in relation to good. See also the Lives of Jesus by Neander, Strauss, Renan, Noack, Hase, Keim, Farrar, and Ederstein; the essay by De Quincy, Stier's *Words of the Lord Jesus*, Tragedies by Elisa Schmidt (1832) and Dulk (1865); and Robert Buchanan's ballad, *Judas Ischariot*.

Judas Maccabæus. See MACCABEES.

Judas' Tree (*Ceris*), a genus of trees of the natural order Leguminosæ, sub-order Casalpineæ. The common Judas' Tree (*C. Siliquastrum*) is a native of the south of Europe and of the warmer temperate parts of Asia. It has almost orbicular, very obtuse leaves. The flowers, which are rose-coloured, appear before the leaves. There is a legend that Judas hanged himself on a tree of this kind. The American Judas' Tree (*C. canadensis*) is very similar, but has acuminate leaves. The flower-buds are frequently used in salads and pickled in vinegar. The wood of both species is very beautiful, veined with black, and takes an excellent polish. The young shoots of the American Judas' tree are used in domestic dyeing, and impart a fine colour to wool.

Jude, EPISTLE OF, one of the smallest and least important books in the New Testament canon, which purports to be by 'Jude, a servant of Jesus Christ, and brother of James.' This Jude is most probably the Judas who was one of the 'brethren of the Lord' (Matt. xiii. 55; Mark, vi. 3). There is a Judas in the list of the apostles, as given by St Luke (vi. 16; Acts, i. 13) and recognised by St John (xiv. 22), occupying the place of one who in the lists of Matthew (x. 3) and Mark (iii. 18) is called Lebbeus or Thaddæus, the traditional evangelist of Edessa. The absence of the epistle in the Peshito is of itself proof, according to Canon Venables (Smith's *Dict. of Bible*), that it is not the work of the last. St Luke describes the apostle Judas as *Ἰούδας Ἰακώβου*, which would naturally mean 'Jude, the son of James,' but has been, without sufficient grounds, rendered in the Authorised Version 'Jude, the brother of James.' But the author of our epistle rather seems to distinguish himself from the apostles (verse 17), and on other grounds there seems conclusive proof that he did not belong to the Twelve.

The epistle is recognised by many who are silent about James, as Clement of Alexandria, the Muratorian Fragment, Tertullian, and Origen; although indeed it is not mentioned by Clement of Rome, Ignatius, Hermas, Polycarp, Papias, or Irenæus. As has been said, it is wanting in the Peshito or Syriac version, and it is classed by Eusebius with James among the *Antilegomena*, or disputed books. Fifty years later St Jerome mentions that, though then received, it had been rejected by many as quoting the apocryphal Book of Enoch (verses 14, 15). Origen tells us that in verse 9 again Jude quotes from another apocryphal book, the lost Assumption of Moses. A more serious objection to Jude's authenticity is the question whether the particular immoral perversions of Christian truth against which it seems to be directed existed in the time of the brother of James, who appears to have been dead before the accession of Domitian (81 A.D.). Davidson, Hilgenfeld, Volkmar, Schenkel, Mangold, Lipsius, Holtzmann, Weizsäcker, and Pfeiderer identify these with the Antinomian Gnosticism of the 2d century, which repudiated God and the angels of the Old Testament as subordinate powers (verses 8-10), Jesus as the merely human organ of the higher Christ (verse 4), and ordinary Christians as people psychically inferior to themselves (verse 19), while it afforded a cloak to libertine tendencies (verses 8, 10, 16). But it may be questioned if the epistle specially applies to Gnosticism proper, as there is no distinct hint at the doctrinal basis of the errors denounced, and the whole may reasonably be interpreted as rebuke to private members of the church who led ungodly lives, mis-interpreting the doctrine of grace as a charter for a licentious life, and were disobedient to spiritual authority, not necessarily applicable to special organised forms of immorality and error yet

to be developed. At the same time it should be remembered that other apostles had already had cause to denounce impurity which had crept into the church (2 Cor. xii. 21; Phil. iii. 19; Rev. ii. 20-22). Clement of Alexandria reads into the epistle a prophetic denunciation of the immoral teaching of Carpoerates, and Renan boldly claims it as a diatribe against Paul.

No reader can overlook the striking parallelism at once in thought and language between Jude and 2 Peter, ii., from which we may feel certain that the one writer had the work of the other before him. It is a difficult matter, however, to determine which of the two was the earlier. Most critics conclude in favour of Jude, although to this there are several serious objections on which a strong case has been constructed by Professor Lumby in *The Speaker's Commentary*.

See the Introductions of S. Davidson, Hilgenfeld, Holtzmann, Salmon, Weiss, and Dods; the works on the New Testament canon by Westcott and Zahn; and the special commentaries in the *Kurtzsch. Exe. Handbuch* (3d ed. Brückner, 1865), Meyer (5th ed. Kuhl, 1887), Stier (1850), Arnaud (1851), Ranpf (1854), Fronmüller (1859), Hoffmann (1875), Reuss (1878), and E. H. Plumptre (1886). See also Ritschl in *Theolog. Stud. u. Krit.* (1861).

Judenhetze. See JEW, p. 329.

Judge is the generic descriptive name given to those who are invested with the power of judging and deciding causes in the highest courts of common law. In Great Britain—though it is otherwise in America—it is not usual to designate the highest class of judges by the epithet of judge, and British lawyers never do so. Thus, instead of saying Judge Blackstone, Judge Pollock, Judge Eldon, the proper description is Mr Justice Blackstone, Chief-baron Pollock, Lord Chancellor Eldon, &c., according to the particular court in which they presided. In Scotland the usual prefix to the name of a judge is Lord; and the judges there, on their appointment, often assume territorial titles in addition to the prefix 'Lord'; Robert Macfarlane, for instance, becoming Lord Ormidale, whilst his wife remained Mrs Macfarlane. In England the judges of the superior courts are only called lords while they sit in court or in chambers. The practice has long been for the crown to confer the honour of knighthood on all the judges of the superior courts of law and equity in England, but not in Ireland or Scotland. All the superior judges are appointed by the crown, and since the Act of Settlement (1701) have held their offices during good behaviour; since 1 Geo. III. chap. 23, they have also continued to hold their appointments notwithstanding the demise of the crown. They can only be removed from their office on the address of both Houses of parliament. They are disqualified from sitting in the House of Commons. Judges in England may sue and be sued in their own courts, but none may be judge in his own case. No action may be brought against the judge of a superior court for anything done in his judicial capacity. Judges of inferior courts are liable to be sued, but only when they have acted in bad faith, or beyond the bounds of their jurisdiction. The term judge is the proper title of the judges of the county courts established in England in 1846. In Scotland the phrase is often applied to all judges, superior and inferior, whenever they have a fixed and determinate jurisdiction, in contradistinction to commissioners, who have an occasional and temporary judicial authority delegated to them.

In the United States the judges of the supreme court are appointed by the president with the consent of the senate; in the courts of the several states they are either appointed by the executive, elected by the legislature, or, as in most states of

late years, chosen directly by popular suffrage. A judge is not liable to a civil action for acts performed as part of his official duty, but he may be impeached for any high crime or misdemeanour.

Judge-advocate-general, the adviser of the crown in proceedings to confirm or revise the decisions of courts-martial. He is also the adviser, in legal matters, of the Commander-in-chief and Secretary of State for War. Before confirmation, the sentences of all courts-martial, with the evidence adduced, are submitted to him; and it is for him to represent to the commander-in-chief any illegality of procedure, or other circumstance rendering it undesirable that the Queen should be advised to confirm the court's decision. He does not advise as to the exercise of the prerogative of mercy. The judge-advocate-general receives a salary of £2000, and is usually a member of the House of Commons, and of the ministry—changing, of course, with the latter. The judge-advocate-general is also the title in the United States for the chief of the bureau of military justice at Washington.

The *Deputy-judge-advocate* is an officer holding a temporary commission as legal adviser of court-martial, to assist the court, and to see that no injustice is done to the prisoner.

Judges. THE BOOK OF (Heb. *Shofetim*—compare Carthaginian *Sufetes*; LXX. *Kritai*, but in Philo *Krimata*, 'judgments'), a canonical book of the Old Testament, the second in the series known as the 'former prophets,' relates to the period in the history of Israel from the death of Joshua to the birth of Samuel. Its authorship—or rather the authorship of any part of it, for it is drawn from more than one source—is unknown, and its final redaction, as is shown by the presence of Deuteronomic and other elements, cannot have taken place until after the exile. Its composite character is shown by the fact that it has two beginnings (see i. 1, and ii. 6). The main section of the book, extending from ii. 6 to xvi. 31, consists of an apparently consecutive narrative, grouped round six principal judges—Othniel, Ehud, Deborah, Gideon, Jephthah, and Samson—the intervals being filled with the history of Gideon's son, Abimelech, and references, more or less brief, to six minor heroes—Shamgar, Tola, Jair, Izabai, Elon, and Abdon. The religious pragmatism of this narrative is obvious; the history falls into running cycles, all corresponding to the scheme indicated at the outset by the words: 'After the death of Joshua the children of Israel did evil in the sight of the Lord, and forsook the Lord God of their fathers. . . . And the anger of the Lord was hot against Israel, and he delivered them into the hands of spoilers. . . . and they were greatly distressed. Nevertheless, the Lord raised up unto them judges, and was with the judge, and delivered them. . . . And it came to pass when the judge was dead that they returned and corrupted themselves more than their fathers. . . . And the anger of the Lord was hot against Israel.' &c. The apparently consecutive character of the narrative disappears when its chronological data are carefully analysed; from these we find that the chronology of the section is based on two artificial alternative schemes, either of which, but not both together, can be reconciled with the datum in 1 Kings, vi. 1. Thus the narrative of the greater judges was originally separate from that of the minor ones. The religious standpoint of this main section of the Book of Judges, taken along with other points of internal evidence, shows that in the main it must have been composed about the 8th century B.C. There are signs of Deuteronomic redaction, however; but, on the other hand, the section contains elements that carry us much further back than the century named—such elements, for example, as the

song of Deborah and the history of Abimelech. Of the remaining portions of the book of Judges, i. 1 to ii. 5 is relatively old—older than the book of Joshua, which relates to the same subject, the conquest of Canaan, but treats it in a much later manner. The closing section of the book is made up of two unconnected and independent narratives of very different dates. The history of Micah and the Danites (xvii. 1 to xviii. 31) is a piece of very old history; that of the Levite and the Benjamites is considered by Wellhausen to be post-exilic, and in any case must be regarded as comparatively very late.

See Wellhausen-Bleek, *Einführung* (1878); also Wellhausen, *Religion of Israel* (Eng. trans. p. 228 *seq.*). There are commentaries by Keil (Eng. trans. 1865), also in Lange's *Biblewerk* (1865), in the *Speaker's Commentary*, and in the *Königl. Bibel-Anstalt* by Bertheau (1845), by Studer (1835), and by Moore of Andover (1896).

Judgment. See HELL, RESURRECTION.

Judicature Acts (1873-76). THE, constituted the English Supreme Court, comprising the High Court of Justice, with a Chancery division (see CHANCERY) and a Queen's Bench division (see COMMON LAW); and the Court of Appeal (see APPEAL).

Judicial Committee. See PRIVY-COUNCIL.

Judicial Factor. See FACTOR.

Judicial Separation. In English law, is the separation of two married persons by order of the Court of Divorce. Married persons may, if they please, mutually agree to live separate, and they may enter into a deed of separation for that purpose, which to some extent is recognised as valid by courts of equity. This is called voluntary separation. A deed of separation is always revocable by consent of the parties, though to some extent binding on each, if the other do not consent to renew the cohabitation. When the parties have not mutually consented to separate, one of them can compel a judicial separation for certain grounds of misconduct. Thus, either party may apply on the ground of adultery, or cruelty, or desertion without cause for two years and upwards. When a husband is convicted of an aggravated assault on his wife, the court before which he is tried may make an order which is almost equivalent to a judicial separation.

Married persons separated by deed or judicial order are still married. Not being divorced, they cannot marry again; but there is no longer the duty of cohabiting. The court may award a certain income to the wife after separation, and may also make orders as to the custody and maintenance of children. But, irrespective of this, the wife becomes, to all intents and purposes as regards her future property, in the same position as if she were unmarried. On the other hand, the husband is no longer responsible for maintaining his wife, except so far as he may have been ordered to pay her alimony, and he is not liable for her future debts. In 1857 the law on this head was materially improved, and a new Divorce Court established. See DIVORCE; also MARRIAGE.

In Scotland the law was changed in 1861, and now nearly coincides with the English law in many respects. Whenever a decree of separation *a mensa et thoro* is obtained at the instance of the wife, all property which she may acquire, or which may devolve upon her, is held entirely separate from and independent of her husband; she can bequeath it by will as if he was dead. She can also enter into contracts, and sue and be sued in her own name, and the husband is no longer liable for necessities or her debts, except so far as he is bound by the decree of separation to pay her aliment. The grounds of

judicial separation in Scotland also are nearly the same as in England.

In the United States the courts used till 1838 partial divorce *a mensa et thoro*; but since then the marriage contract is either wholly dissolved or the courts refuse to interfere.

Judith, a Jewish heroine, who saved her native town, Bethulia, by a deed of unexampled daring and devotion. She made her way into the hostile camp, and into the very tent of Holofernes, general of Nebuchadnezzar. The general was bewildered by her beauty, and she plied him with wine till he sank overpowered upon his couch. Then she cut off his head, and found her way out carrying it with her. Her townsmen were inspired with a sudden enthusiasm, rushed out upon the enemy, and completely defeated them. The tale is not mentioned by Josephus, and has from an early period been held to be an allegory. It forms the subject of the apocryphal book of *Judith*, the composition of which is put variously between the time of the Maccabees and the time of the second Jewish war under Hadrian. The exploit of Judith has given a frequent subject to art: here we may merely mention the bronze group of Donatello at Florence; the paintings by Botticelli, Cranach, Horace Vernet, and Etty; the poetic elaborations of the theme by Hans Sachs, Opitz, and Heibel.

Judson, ADONIRAM, American missionary to Burma, was born in Malden, Massachusetts, August 9, 1788. He graduated at Brown University in 1807, passed through Andover theological seminary, and in 1812 married Ann Haseltine and sailed for India. There they joined the Baptists. After many difficulties they settled in Rangoon, and ere long Judson began to preach and write in Burmese, translating portions of the New Testament (1817-21). He received the degree of D.D. from Brown University in 1823. In 1824 the missionaries removed to Ava, where, during the Burmese war, Judson was imprisoned; and he subsequently laboured at Amherst, Promé, Rangoon, Maulmain, and, with remarkable success, among the Karen jungles. His devoted wife died at Amherst in 1826. In 1833 his translation of the Bible was completed, and this was followed by a Burmese-English dictionary. Judson's second wife, widow of G. D. Boardman (q.v.), died in 1845 on the voyage home to America. He returned to Burma in 1846, and completed his dictionary at Maulmain, but his health failed, and he died at sea, on his way to Mauritius, 12th April 1850. His first wife was author of a *History of the Burmese Mission*, and assisted her husband with his translations. His third wife, Emily Chubbuck (1817-54), was known in the literary world as Fanny Forrester. See Lives by Wayland (Boston, 1853) and Judson's son Edward (New York, 1883).

Juggernaut, or PURI, is the name of a town on the coast of Orissa, at the southern end of the delta of the Mahanadi, celebrated as one of the chief holy places in India. With a resident pop. of 22,000, and some 6000 lodging-houses for pilgrims, it owes its reputation to a temple erected there in honour of Vishnu, and containing an idol of this Hindu god, called *Jagannath* or *Juggernaut*, a corruption of the Sanskrit word *Jagannatha*—i.e. Lord of the World. It was long a sacred city of the Buddhists, the abode of the Golden Tooth of Buddha. The first historical mention of Jagannath is in 318 A.D. He represents Vishnu in all his manifestations, and is in a special sense the god of the people. The great festivals sometimes bring 200,000 pilgrims; and the annual offerings may amount to as much as £37,000, besides Jagannath's revenue of £31,000 from lands and various religious houses. The temple enclosure

comprises 120 temples, the chief pagoda being that of Jagannath, with a tower 192 feet high. There are twenty-four annual festivals in his honour, the chief being the ear festival, when Jagannath (who is armless) is dragged on his ear (45 feet high, 35 feet square, with sixteen wheels, each 7 feet in diameter) to his country-house. This is less than a mile distant from the temple, but the heavy sand extends the short journey to several days, until the exhausted devotees resign the task to professional ear-pullers, who have also to assist the idol home again. The ear festival has been currently believed to be the occasion of numerous cases of self-immolation, the frantic devotees committing suicide by throwing themselves before the wheels of the heavy ear. This is, it would appear, a calumny of English writers. See Sir W. W. Hunter's work on Orissa (1872), in which he 'carefully examined the whole evidence on the subject, from 1580, when Abul Fazl wrote, through a long series of travellers, down to the police reports of 1870,' and came to 'the conclusion which H. H. Wilson had arrived at from quite different sources, that self-immolation was entirely opposed to the worship of Jagannath, and that the rare deaths at the ear festival were almost always accidental.'

Jugglers. See CONJURING.

Jugular Vein. See THROAT, VEIN.

Jugurtha, king of Numidia, son of Mastanabal, who was a natural son of Masinissa, was carefully educated along with Adherbal and Hiempsal, the sons of his uncle Micipsa, who succeeded Masinissa on the throne. After Micipsa's death Jugurtha soon caused Hiempsal to be murdered (118 B.C.), whereupon Adherbal fled to Rome. Jugurtha succeeded in bribing great part of the Roman senate, and obtained a decision in his favour, freeing him from the charge of the murder of Hiempsal, and assigning him a larger share of the kingdom than was given to Adherbal (117 B.C.). But Jugurtha soon invaded Adherbal's dominions, and, notwithstanding injunctions by the Romans to the contrary, besieged him in the town of Cirta (112 B.C.), and caused him and the Romans who were captured with him to be put to death with horrible tortures. Thereupon war was declared against Jugurtha by the Roman people; but, by bribing the generals, Jugurtha contrived for years to baffle the Roman power. At last the consul, Q. Cæcilius Metellus, proving inaccessible to bribes, defeated him in 109 and 108 B.C., so that he was compelled to flee to the Mauretanian king, Bocchus. Marius, who succeeded Metellus in the command, carried on the war against Jugurtha and Bocchus, till at last Bocchus delivered him up to Sulla, then the quaestor of Marius. He was carried in the triumph of Marius, January 1, 104 B.C., and then flung into a dungeon under the Capitol to die of hunger. Our interest in Jugurtha is entirely due to the masterpiece of history in miniature which Sallust devoted to his story.

Jujube (*Zizyphus*), a genus of spiny and deciduous shrubs and small trees of the natural order Rhamnaceæ. The species are pretty numerous. The Common Jujube (*Z. vulgaris*) of the south of Europe, Syria, &c. is a low tree, which produces a fruit resembling an olive in shape and size, red or sometimes yellow when ripe. The fruit is dried as a sweetmeat, and forms an article of commerce. *Syrup of jujubes* is used in coughs, fevers, &c.; but the *jujube paste* or *pâte de jujube* of the shops of Britain is made of gum-arabic and sugar, without any of the dried jelly of this fruit.—The jujube of India (*Z. Jujuba*) is a similar small tree, with round or oblong fruit, sometimes of the size of a hen's egg.—A Chinese species of jujube (*Z. nitida*)

has a very pleasant yellow fruit about an inch long; and other species not much inferior are found in Africa, South America, and other warm countries.—The Lotus (*Z. Lotus*), a shrub 2 or 3 feet high, a native of Persia, the north of Africa, &c., produces in great abundance a fruit about as large as a sloe, and with a large stone, but having a sweet farinaceous pulp, which the natives of some parts of Africa make into cakes resembling gingerbread. A kind of wine is sometimes made from it. This is believed by many to be the Lotus of the ancient Lotophagi celebrated by Homer.—*Z. Spina Christi*, another native of the countries near the Mediterranean, is sometimes said to be the plant from the branches of which our Saviour's crown of thorns was made, and is therefore called Christ's Thorn and Jew's Thorn, names which, for the same reason, are also given to *Pulsatilla aculeatus*. The fruit is about the size of a sloe, oblong, and pleasantly acidulous.—*Z. zeylanica*, a native of the coast of Coromandel, has greenish downy fruit about the size of a cherry, with an edible kernel tasting like a filbert. The tree, which grows about 20 feet high, yields a hard, durable, yet light timber, which when mature assumes a fine orange colour.

Jujuy, the most northerly province of the Argentine Republic, is a mountainous tract, bounded on the W. and N. by Bolivia, and has an area of about 27,000 sq. m. Its minerals are rich, but not worked to any extent. The chief industries are agriculture and cattle-raising; sugar and wheat are the principal crops. The exports (mainly to Bolivia) consist of cattle, mules, fruit, chicha brandy, skins, gold-dust, and salt. Pop. (est. 1888) 90,000.—The capital, JUJUY, on the San Francisco River, 44 miles N. of Salta, has a custom-house, a national college, a girls' normal school, sugar-houses and refineries, and 6000 inhabitants.

Jukes, JOSEPH BEETE, geologist, was born near Birmingham, on 10th October 1811, and graduated from St John's College, Cambridge, in 1836, having studied geology under Sedgwick. In 1839 he was appointed geological surveyor of Newfoundland, and in 1842 he took part as naturalist in the exploration and survey of Torres Strait, New Guinea, and the east coast of Australia. After his return home he surveyed part of North Wales for the Geological Survey of the United Kingdom (1846-50), and in 1850 became local director of the survey in Ireland. He also lectured on geology in the Museum of Irish Industry and at the Royal College of Science in Dublin. He died in that city, 29th July 1869. Besides writing many memoirs on geological and kindred subjects, Jukes published *Excursions in and about Newfoundland* (2 vols. 1842), *Narrative of the Surveying Voyage of H.M.S. 'Fly,' in Torres Strait, &c.* (1847), and *A Sketch of the Physical Structure of Australia* (1850); but he is best known as the author of the *Student's Manual of Geology* (1857, 5th ed. 1890). See his Letters, edited by C. A. Browne (1871).

Julfa, a suburb of Ispahan (q.v.) in Persia.

Jülg, BERNHARD, philologist, was born at Ringelbach, in Baden, 20th August 1825; studied classical and comparative philology at the universities of Heidelberg and Berlin; and after teaching in gymnasia at Heidelberg, Freiburg, and Rastatt became in 1851 extra-ordinary professor of Classical Philology at Lemberg; in 1853 ordinary professor at the university of Cracow, and in 1863 at Innsbruck, where he died 14th August 1886. Besides his studies in comparative philology, extended to embrace the tongues of eastern Asia, he devoted much attention to the question of comparative folk tales.

Of his scientific publications the most important are

Vater's *Litteratur der Grammatiken, Lexika und Wörter-sammlungen aller Sprachen der Erde* (2d ed. 1847), *Die Märchen des Südkar* (1866), two collections of Mongolian *Märchen* (1867 and 1868), a work on echoes of the Greek heroic epics amongst the Mongolians (1869), and *Ueber Wesen und Aufgabe der Sprachwissenschaft* (1868).

Julia, the only child of the Roman emperor Augustus, was his daughter by his second wife, Scribonia, and was born in 39 B.C. She was distinguished for her beauty and talents, and was married at fourteen to Marcus Claudius Marcellus, the sister's son of Augustus. After his death two years later, she was married to Marcus Vipsanius Agrippa, to whom she bore three sons and two daughters. He in his turn died in the year 12 B.C., whereupon Julia was given in marriage next year to Tiberius; his mother, Livia, the stepmother of Julia, persuading Augustus to this, in order to secure the succession of Tiberius to the throne. The marriage was an unhappy one, and the conduct of Julia herself far from irreproachable; but it was Livia's hatred rather than any lofty regard for virtue that procured the unhappy Julia's banishment to the isle of Pandataria. From Pandataria, whither her divorced mother, Scribonia, accompanied her, she was removed to Rhegium, where she was allowed by Tiberius to remain destitute even of common comforts till her death in 14 A.D. Her son, Agrippa Postumus, was put to death by Tiberius shortly before the death of his mother. Her other sons, C. and L. Caesar, died in early age. Her daughters survived her. The elder, Julia, inherited her mother's frailty, and died in 28, in the isle of Trimerus, on the coast of Apulia, whither she had been banished by Augustus twenty years before for adultery. The younger, the virtuous Agrippina (q.v.), died in 33, in Pandataria, to which she had been banished by Tiberius.

Julian, surnamed the Apostate, on account of his renunciation of Christianity, Roman emperor from about the end of 361 to the middle of 363 A.D., was born at Constantinople in the later half of the year 331. He was the youngest son of Julius Constantius, the half-brother of Constantine the Great, and his full name was Flavius Claudius Julianus. On the death of the great Constantine in May 337, and the accession of his three sons, there was a general massacre of the male branches of the younger line of the Flavian family descended from Constantius Chlorus and his second wife Theodora. Thus perished the father of Julian, his elder brother, paternal uncle, and cousins, while he himself and his elder half-brother Gallus were alone spared as too young to be dangerous. He lived a loveless youth, under rigorous espionage, at Macellum in Cappadocia and at Nicomedia, embittered moreover by the terrible tragedy he had just escaped, which stripped him of all belief in the reigning religion, and drove his ardent temperament for relief into the literary and philosophical studies of his time. His secret apostasy seems to have been begun at Nicomedia and consummated at Ephesus under the influence of the Neoplatonist Maximus. In 355 he spent a few happy months at Athens in the study of Greek philosophy, and among his fellow-students and acquaintances here were the future Bishops Basil and Gregory Nazianzen. Gallus had been put to death the year before, and in November 355 Julian was summoned to Milan to assume the rank of Caesar, and marry the emperor's sister, Helena.

The shy young student moved awkwardly amid the atmosphere of policy and intrigue at the court, but during the next five years he found more congenial occupation in the camp, and by his skill and vigour showed that he was a soldier as well as a philosopher. He overthrew the stubborn and victorious Alemanni near Strasburg, subdued the

Frankish tribes along the Rhine and across the river, and fixed his winter quarters at Paris. He endeared himself to the people by lightening the public burdens, and to the soldiers by his personal courage, his success in war, and the severe simplicity of his private life. In April 360 the emperor, alarmed at his growing popularity, demanded that he should send some of his best troops to serve against the Persians, but his soldiers rose in insurrection and proclaimed him Augustus. He occupied some time in consolidating his power, then sent forward one portion of his army through Rhaetia and Noricum, another by the northern confines of Italy, while he himself with 3000 chosen soldiers plunged into the gloomy recesses of the Marejan or Black Forest, and sailed down the Danube as far as Sirmium, where he waited to unite his forces. Here he first threw off the mask and openly declared himself a pagan. Here also he learned of the opportune death of his cousin at the foot of Mount Taurus (November 3, 361), which opened up to him the government of the world. The first winter he spent in the imperial city in a course of public reforms, sweeping away a host of corrupt officials who had long battered at will on private bribes and exactions. Towards Christians and Jews alike he ostentatiously adopted a policy of toleration, but none the less he devoted himself with all the enthusiasm of the convert to the task of restoring the dignity of the old religion. He was assiduous in the practice of divination and all other superstitious ceremonies, reopened and rebuilt the deserted temples, and lavished his patronage upon the time-serving reproaches who deluded him into a belief in the reality of their conversion. He stripped the church of its peculiar privileges by every means short of persecution, but was mortified to the heart by the little success of his ardent propagandism alike among the citizens and the soldiers, although the latter were unable to pay their due worship to the person of the emperor without seeming to bow to idols, from the subtle way in which the imperial and the divine symbols were deliberately intermingled. As soon as he had settled affairs in Constantinople he set out on a journey through Asia Minor to Antioch. Here he lived from July 362 to the March of the following year, and found its luxurious citizens as indifferent to his paganism as to Christianity. Yet his zeal in reformation was less hateful than his economic policy in fixing an arbitrary price on corn in order to stave off a threatened famine. The impudent Antiochenes revenged themselves upon the sensitive emperor by lampoons and ridicule; yet he restrained his resentment, or confined it to the pages of his *Misopogon*, an ironical satire on their effeminate manners, full of the interest of self-revelation. His famous attempt to rebuild the temple at Jerusalem was intended to falsify the cherished prophecies of Christianity no less than to please the Jews; and the balls of flame which brought the work to a standstill were with one accord accepted as miraculous evidence of the special interposition of heaven. Much has been written on this startling story, which even Gibbon was obliged to receive with some respect, and the case for the miracle has been admirably put by Newman in his *Essay on the Miracles in Early Ecclesiastical History* (1842).

In March 363 Julian set out on his long meditated expedition against the Persian king Sapor, and after a tedious march crossed the Tigris, and advanced to the walls of Ctesiphon. He was led to advance farther by the false promises of a Persian traitor, and was at length forced to retreat through a barren country, under a burning sun, and harassed by the swarms of the Persian cavalry. The enemy were repeatedly beaten off, but in one

of the attacks the emperor was wounded by a spear-thrust in the side and fell fainting from his horse. Theodoret tells us how as his blood spouted from the wound he exclaimed, 'Thou hast conquered, O Galilee!'—a poetical tale that is at least an embodiment of a historic truth. He was carried to his tent, where, after a few words of brave philosophy to his weeping friends, he died about midnight on the evening of June 26, 363.

'Julian's life was an accident,' says Bengnot, 'and at his death events reverted to their natural channel.' He failed completely in the aims of his life; and history, says Mr Rendall, shows few sadder examples of noble views distorted, great powers misapplied, and high aims worse than wasted. He was at once a soldier and a statesman wrapped in a student's cloak, and his character was made up of strange contrasts. He was superstitious and fanatical; loquacious, restless, and irritable; without either the calm dignity of the Roman, or the graceful ease of the Greek; vain, pedantic, and hungry for applause; yet with a heart passionately devoted to truth and athirst for the cooling waters of divine philosophy. He was chaste and abstinent, just, liberal, and affectionate; yet the story of his wasted life, with more than the pathos, lacks all the charm that hangs around the brow of the imperial philosopher Aurelius.

To Gregory Nazianzen, Chrysostom, Sozomen, Theodoret, and all the early Christian writers, the Apostate was a monster of wickedness; to Claudius Mamertinus he was a figure above all taint of human infirmity. The voracious and competent military historian Ammianus Marcellinus and the rhetorical Libanius are alike warm, yet discriminating, panegyrists. Of modern writers the most illustrious is Gibbon, whose account is fairly just and one of the most splendid passages in historical literature. Yet, as Mr J. W. Barlow has shown (*Hornathona*, vol. iii, 1879), his picture of Julian has suffered from the necessity for the appearance of severe impartiality. He disliked his superstition, and throughout he damns him with faint praise, and sneers at his virtue, as if it lacked the merit of effort. Even the allusion to his uncleanly personal habits—his long nails, ink-stained hands, and populous beard—is scarce justified by the evidence, being based on a mere ironical exaggeration of Julian's own, in his *Misopogon*, to justify the excessive contempt of the over-luxurious citizens of Antioch.

Julian's extant writings are a series of *Epistles*, mostly addressed to men of letters; nine *Orations*; *Cæsars*, a series of satires in which past Cæsars are treated to caustic satire from Silenus; and the *Misopogon*. His most important work, *Kata Christianism*, is lost. A serviceable edition is that by F. C. Hertlein (Leip, 1875). See vols. iii, and iv, of the Duc de Broglie's *L'Église et l'Empire Romain au quatrième Siècle* (1856-69); Neander, *Kaiser Julian und sein Zeitalter* (1813; Eng. trans. 1850); J. F. A. Mücke, *Flavius Claudius Julianus: nach den Quellen* (1867-69); and G. H. Rendall, *The Emperor Julian: Paganism and Christianity*, an expanded Hulsean Essay (1879); Bishop John Wordsworth's article in vol. iii. (1882) of Smith and Wace's *Dictionary of Christian Biography*; and Alice Gardner, *Julian, Philosopher and Emperor* (1895). The essay by Strass, *Der Romantiker auf dem Thron der Cæsaren* (1847), is only a clever pamphlet aimed at Frederick William IV. of Prussia, and his religious reaction. Ibsen's splendid drama, *Emperor and Galilean* (1873; Eng. trans. 1876), sketches a new ideal culture for the world to succeed the Christian, as it replaced the classical.

Julian Calendar. Epoch. Year. See CALENDAR, CHRONOLOGY, YEAR.

Julien. STANISLAS AIGNAN, a great French Sinologue, was born at Orleans, 19th September 1799, and became at twenty-one an assistant professor at the Collège de France. Ere long, under Abel Régnat, he gave himself with such zeal to the study of Chinese that he mastered its difficulties in less than a year, and actually executed a Latin translation of the philosopher Mencius (1824-

26). From that time his labours were directed with uninterrupted assiduity to the languages and literature of the Far East. Ancient and modern Chinese, Manchu, Sanskrit, and the Mongolian tongues were alike familiar to him; and at the same time he knew almost all the European languages. He succeeded Régnat in 1832 at the Collège de France, became in 1839 keeper of the Royal Library, and in 1854 head of the Collège Impériale. He was also conservator of the Bibliothèque Impériale, and was specially charged with the oversight of the Chinese department. He died February 14, 1873. Julien gave admirable French versions of specimens of the Chinese drama in his *Hou-tan-ki* ('the Circle of Chalk,' 1832) and his *Tchou-chi-kou-cul* ('the Chinese Orphan,' 1834); of Chinese romances, by his *Blanche et Bleu* (1834), *Les deux Cousins* (1863); and *Arabianus*, a collection of Indian novels (1859). He was also the first to make Chinese poetry intelligible. But a more valuable service still than these was his translating the great manuals of Chinese religion and philosophy, such as the *Livre des Récompenses et des Peines* (1835), in which are contained the doctrines of Tao-se; the *Livre de la Voie et de la Vertu* (1841) by Lao-tse, written in the 6th century B.C., and forming the oldest and most illustrious monument of Chinese philosophy; and above all, the *Histoire de la Vie d'Houen-Tsang et de ses Voyages* (1852), a work of immense importance for the earlier history and geography of India, and the knowledge of Buddhism. But not content with these brilliant labours, Julien translated Chinese treatises on silk-culture and the manufacture of porcelain. His splendid *Syntaxe Nouvelle de la Langue Chinoise* appeared 1869-70.

Jülich (Fr. *Juliers*), a town of Rhenish Prussia, on the Roer, 20 miles by rail N.E. of Aix-la-Chapelle. It is the *Juliacum* of the Romans. Until its fortifications were razed in 1860 it ranked as a fortress of the second class. Pop. 5234.—From the 12th century Jülich was the capital of an independent countship, created a duchy in 1356. In 1423 Jülich and Berg (q.v.) were united; and Cleves was added in 1521. In 1609 a dispute arose as to the succession, which was not settled till 1666, when a decision was given in favour of the House of Pfalz-Neuburg, the Elector of Brandenburg obtaining Cleves. The Pfalz-Neuburg family becoming extinct in 1742, Jülich passed to the Pfalz-Sulzbach branch, afterwards electors of Bavaria. In 1801 the duchy was annexed to France, in 1814 to Prussia. See Ritter, *Der Jülicher Erbfolgestreit* (2 vols. 1874-78).

Julius, the name of three popes, of whom the second and third deserve especially to be noticed.—JULIUS II., originally Giuliano della Rovere, a nephew of Sixtus IV., was born at Albignola, near Savona, in 1443. He was vehemently opposed during his cardinalate to the designs of Alexander VI. for the aggrandisement of his family, and one of his earliest measures on his election to the pontificate, in 1503, was to resume possession of the duchy of the Romagna, which had been bestowed upon Caesar Borgia. Julius was himself beyond all suspicion of nepotism or selfish designs of aggrandisement; but his public career during his pontificate was almost entirely devoted to political and military enterprises for the complete re-establishment of the papal sovereignty in its ancient territory—Bologna, Ferrara, &c. and for the extinction of foreign domination and foreign influence in Italy. In pursuing his designs, for the purpose of compelling from the republic of Venice the restitution of the papal provinces on the Adriatic, Julius not only entered into the league of Cambrai with the Emperor Maximilian, Ferdinand of Aragon, and Louis XII.

of France, but had recourse to spiritual arms, by placing the republic under the ban of the church; and on the submission of Venice, apprehending the ambitious designs of Louis, he withdrew from the league, and entered into an opposite alliance, the 'Holy League,' to which Spain and England were parties. During this bitter quarrel with Louis XII. the latter attempted, but ineffectually, to enlist the sympathies of the church against the pope. The Council of Pisa, which was convened under Louis's influence, was an utter failure; and the opposing council, fifth of the Lateran, assembled by Julius, but not brought to a close during his lifetime, completely frustrated the designs of the French king. It has been said without grounds that Julius, in his hatred of France, tried to draw even the Turks into the league, but on the contrary one of his most cherished dreams was a holy war under his own command. As an ecclesiastical ruler Julius has little to recommend him in the eyes of churchmen. As a political sovereign he is described by Ranke as 'a noble soul, full of lofty plans for the glory and weal of Italy;' and Professor Leo considers him, with all his defects, as one of the noblest characters of that age in Italy. He was a liberal and judicious patron of art, and a friend of the rising literature of the time. He died in February 1513. There are Lives by Dumesnil (Paris, 1873) and Brosch (Gotha, 1877).—JULIUS III., born at Rome in 1487, was known before his elevation to the pontificate as Cardinal del Monte. He was one of the three legates of the pope under whom the Council of Trent was opened; and after his election to the papacy in 1550 he himself reopened (in 1551) that council, which had been suspended for upwards of two years. He is connected with English history as having sent Cardinal Pole to organise with Mary the reunion of the kingdom with Rome; but his general government of the church is marked by no very striking events, and his private character is sullied by the taint of nepotism. He died in March 1555.

Jullien (originally JULIEN), LOUIS ANTOINE, was born at Sisteron, in the French department of Basses Alpes, 23d April 1812. He studied at Paris, and became a conductor of concerts there in 1836; but leaving in 1838, made London his headquarters, and did much to popularise music in England by means of large bands, the best available players and singers, and the most attractive pieces, including his own 'Monster Quadrilles.' He became bankrupt in 1857, and retired to Paris, where he was imprisoned for debt. He died in a lunatic asylum, 14th March 1869.

Jullunder (*Jalundhar*), a city of the Punjab, stands in the Doab or rich alluvial plain of the same name between the Sutlej and the Beas, in 31° 21' N. lat. and 75° 31' E. long., on the Sindh-Punjab and Delhi Railway between Umballa and Unrisar. The soil of the neighbourhood is very productive; and the city, though fallen from its former greatness, in 1891 had 66,292 inhabitants. Jullunder is a very ancient city, founded before Alexander's invasion of India, and is referred to in the *Mahabharata*. It gives its name to an administrative *district* of 1433 sq. m. area (pop. 907,583), and to a *division* of 12,600 sq. m. area (pop. nearly 3,000,000).

Julus, or JULIUS, a genus of Millepedes, in the class Myriapoda (see CENTIPEDE).

July, the seventh month of the year in our calendar, fifth in the Roman calendar, where it was called Quintilis ('the fifth'). Originally it contained thirty-six days, reduced first to thirty-one, then to thirty, but was restored to thirty-one days by Julius Cæsar, in honour of whom it was named

July (Lat. *Julius*), his birthday falling on the 12th. In this month the sun leaves Cancer and enters the sign of Leo. According to Dove, the mean temperature of July at London is 64° F.; at Dublin, 61; at Archangel, 60; at Berlin, 66; at Rome, 76. The average summer temperature at New York is 72.62; at San Francisco, 58.04.—The 'July Revolution' is that in France in July 1830, by which Charles X. was set aside, and Louis-Philippe became king.

Jumièges, ROBERT OF, Archbishop of Canterbury, was a Norman by birth, and came to England in the train of Edward the Confessor, over whom he acquired great influence. He was made Bishop of London in 1044, and Archbishop of Canterbury in 1050, and from the first was the head of the anti-English party which gained a temporary triumph in 1051 by the banishment of Earl Godwin and his sons. Their return next year quickly drove him into exile in Normandy. The Witenagemot stripped him of his archbishopric, and he spent the remainder of his life in the monastery of Jumièges, 16 miles SW. of Rouen.

Jumièges, WILLIAM OF, a Norman monk who compiled in Latin a history of the Dukes of Normandy from Rollo down to 1071, which is of some value in the contemporary part—the story of the Conquest and early reign of William I. It is printed in Migne's *Patrologia Cursus Completus* (vol. cxlix.).

Jumilla, a town of Spain, 36 miles N. by W. of Murcia, cultivates the vine and esparto grass, and manufactures salt, jurs, silk, &c. Pop. 13,890.

Junna, or JAMUNA, the principal feeder of the Ganges, has its course wholly in Hindustan. Its source, at a height of 10,849 feet above the sea, is in 31° 3' N. lat. and 78° 30' E. long., 5 miles N. of Jamnatri. After a southerly course of 95 miles it breaks into the plains from the Siwalik Hills at an altitude of only 1276 feet. It continues to flow south as far as Hanipur, beyond Agra, and then turns to the east, finally joining the Ganges from the right 3 miles below Allahabad, after a total course of 860 miles. As a rule its banks are high and craggy. Many tributaries add their waters to swell its current. Area of the drainage basin, 118,000 sq. m. The towns of Delhi, Agra, Ferozabad, Etawah, and Allahabad stand on its banks. From each bank of the river, where it emerges from the Siwalik Hills, a canal has been constructed for irrigation purposes—the Eastern Junna Canal (1823-30), on the left bank, 160 miles, and the Western (1817-25), 433 miles.

Jumpers, a term given by opponents to the Shakers (q.v.), as also to some Welsh Methodists, assumed to 'jump' as part of divine worship.

Jumping. See ATHLETIC SPORTS.

Jumping Hare (*Pedetes caffer*), a South African rodent, *Spring Hare* of the Dutch colonists, belonging to the same family (Dipodidae) as the Jerboas (q.v.). The head much resembles that of a hare, although the ears are shorter; the form of the body is also like that of a hare, but the hind-legs are very long and strong, like those of a kangaroo, and the toes both of fore and hind feet are armed with great claws; and the tail is long and bushy. Its powers of leaping are extraordinary; it clears 20 or 30 feet at a bound. Night is its time of activity, and it then makes mischievous inroads on fields and gardens. Its flesh is eaten. Its range extends from Mozambique and Angola to the Cape.

Junagarh, capital of a native state (area, 3283 sq. m.; population, 390,000) of India, in the Bombay Presidency, is situated on the peninsula of Kathiawar, NW. of Bombay. One of the most

picturesque towns in India, it has an old citadel, which contains several Buddhist caves, as does also the ditch surrounding it (see Dr Burgess, *Antiquities of Cutch and Kathiawar*). Pop. (1881) 24,679; (1891) 31,640.

Juncea, or JUNCEÆ, a natural order of endogenous plants, herbaceous, generally perennial, with creeping root-stock; narrow, often fistular leaves; regular flowers; the perianth 6 partite; the stamens six; the fruit a 3-valved capsule. This order is nearly allied to Liliacæ, notwithstanding very great difference of aspect; for rushes (*Juncus*) are the best-known examples of it. The species, about 200 in number, are mostly natives of cold and temperate climates.

June, the sixth month of the year in our calendar, but the fourth among the Romans. It consisted originally of twenty-six days, to which four were added by Romulus, one taken away by Numa, and the month again lengthened to thirty days by Julius Cæsar, since whose time no variation has taken place. During this month the sun leaves the sign of Leo and enters that of Cancer. Dove gives the mean temperature of this month at London as 61° F.; Dublin, 58°; Paris, 63°; Vienna, 67°; Rome, 71°.

Jung, JOHANN HEINRICH, generally called JUNG STILLING, an original German writer, was born at Im-Grund, in Nassau, 12th September 1740. At first he pursued his father's callings—tailor and village schoolmaster; then (1768) he became a student of medicine at Strasburg, where he was intimate with Goethe, who admired his simple, pure, affectionate nature (see *Wahrheit und Dichtung*, ii.). Next he settled (1772) as a medical practitioner at Elberfeld, and won fame as an operator for cataract. Subsequently he held the professorship of Political Economy at Marburg (1787–1804) and Heidelberg. He died at Carlsruhe, 2d April 1817. He was brought up in a pietistic circle, and the effects of his early training clung to him all his life. Although he wrote some semi-mystical, semi-pietistic romances, and later in life works on political economy, he only deserves to be remembered for his charming autobiography, *H. Stilling's Jugend, Junglingsjahre, Wanderschaft, Hausliches Leben, und Lehrjahre* (5 vols. Berlin, 1777–1804; Eng. trans. 1835). His works were published in 12 vols. (Stutt. 1843–44).

Jung, SIR SALAR, chief minister to the Nizam of Hyderabad, was a member of a princely family which since the founding of the Nizam's dynasty in 1713 had furnished the state with its chief ministers, and was born in 1829. Under his uncle, the chief minister, Salar Jung was trained in official work, and in 1853 succeeded his uncle in his important office. He at once began to reorganise the administration of the state, then in a most deplorable condition. The finances were in such a state that the British government had even to pay the troops the Nizam was permitted by treaty to maintain in his own name; and in order to repay the loan the province of Berar was ceded to the British. Salar Jung's first care was to reduce to obedience the mercenary Arab soldiery. Then the robber chiefs of the hill districts were crushed; courts of justice were established at Hyderabad; the police force was organised; the construction and repair of works of irrigation were attended to; and schools were established. During the Mutiny of 1857 Sir Salar Jung remained faithful to British interests in face of the opposition of the people, who sided with the insurgents. The Nizam Afzul, an apathetic, suspicious, and capricious monarch, had lent his reforming minister no aid; he had rather hampered and hindered him. But on his death in 1869 Sir Salar Jung shared with

the most powerful noble of Hyderabad the post of regent. In 1876 he visited England with the hope of obtaining the restoration of the Berar province, but in this he was disappointed. After thirty years of wise government, he died suddenly on 8th February 1883. He was a Knight Grand Commander of the Star of India.

Jung Bahadur, SIR, prime-minister to the Maharajah of Nepal, was born in 1816. His uncle held a high position under the government of Nepal, but was murdered at the instigation of the queen, who appointed the nephew, Jung Bahadur, commander-in-chief of the army. When in 1846 the premier was assassinated, Jung Bahadur took vengeance upon the leading chiefs concerned in the crime and made himself prime-minister. A conspiracy against him was quickly quenched in blood; the queen and the witless king were banished; and the heir-apparent was raised to the throne. During the Mutiny of 1857 he showed his friendly feeling to the British by sending a body of Goorkha troops to their assistance. Jung Bahadur was knighted and received a Grand Cross of the Star of India. He died suddenly, 25th February 1877.

Jungermannia, a Linnean genus of cryptogamous plants, containing a great number of species, which some modern botanists have divided into many genera, and some have even formed into an order, Jungermanniaceæ, although it is more generally regarded as constituting a sub-order of Hepaticæ (q.v.). The distinctive characters of the sub-order are that the *spore-cases* open by four valves, and that the *spores* are mixed with *clavus*. The species much resemble mosses in appearance. Many are natives of Britain, some of them very common in moist places. The tropical species are very numerous, and some of them are to be found even on the young shoots and leaves of plants.

Jungfrau ('the Maiden'), a magnificent peak of the Bernese Alps, attains a height of 13,671 feet. It received its name either from the unswayed purity and dazzling brightness of the snow by which it is covered, or from the fact that no traveller had ever reached its highest point. Its summit was first ascended by two Swiss gentlemen, named Meyer, in 1811. In 1890 a railway from Lauterbrunnen to its summit was projected.

Jungle, a term now fully adopted into the English language from Bengal (Sanskrit *jungala*, 'desert'), and employed to designate those thickets of trees, shrubs, and reeds which abound in many parts of India, and particularly in the unhealthy tract called Terai or Tarayani, along the southern base of the Himalaya, and in the Sunderbans (q.v.) at the mouth of the Ganges. The jungles are often impassable, from the thick growth of underwood, tall grasses, and climbing plants. The soil is generally swampy, and fever and other diseases abound. Tigers and other beasts of prey, elephants, boars, deer, and other quadrupeds may be found in great numbers in these thickets, with gigantic snakes, and multitudes of monkeys. The jungle flora and fauna are very peculiar, and the moisture and heat carry a tropical vegetation beyond its usual limits northward to the lower valleys of the Himalaya. See INDIA, BENGAL.

Jungle-fowl, the name given in India to the wild species of Galline (*Gallus ferrugineus*) which is the parent of our domestic barn door fowl, and to three other closely allied species (see POULETRY).

Juniper (*Juniperus*), a genus of trees and shrubs of the natural order Conifera, sub-order Cupressineæ, having uni-sexual flowers, the male and female generally on separate plants, and the fruit a fleshy *quillule* (popularly a *berry*), containing

three small nuts. The species are all evergreen, and have small, narrow, rigid leaves, which are opposite, or in whorls of three or four, or imbricated in four rows. They are natives chiefly of temperate and cold regions, and are found in Europe, Asia, Africa, and America. The Common Juniper (*Juniper communis*) is found in all parts of Europe and the north of Asia, and in the northern parts of North America. Only in favourable circumstances does it become a tree of 15, 20, or at most 30 feet in height, and in general it is only a shrub from 2 to 6 feet high. The fruit takes two years to ripen. It is round, of a bluish-black colour, with a whitish bloom; is of the size of a small currant, and is produced in great abundance.



Fig. 1.

a, *Juniperus communis*; *b*, *J. sabina*; *c*, *J. chinensis*.

The little nuts or stones of the fruit have on the shell three glands, which abound, before ripening, in an essential oil—*Oil of Juniper*—present also in the young wood. This oil changes to a true turpentine when the fruit reaches maturity, so that to obtain the oil the green fruit must be used. The wood is yellowish red, brownish in the heart, hard, and fragrant. When of sufficient size it is much valued by turners. It is also used for veneering. The berries have a strong and peculiar flavour, and are much used for flavouring gin, which derives its name from them (see GIN). They also enter into several medicinal preparations, being stimulant, sudorific, and diuretic.—Oil of juniper is lighter



Fig. 2.—Branch of *J. communis*, with fruit.

than water; specific gravity, 0.839. It is limpid and nearly colourless, and is obtained by distilling the unripe fruit, or the twigs, with water. — Spanish Juniper (*J. oxycedrus*) grows in arid situations in the countries round the Mediterranean Sea. Its fruit is about the size of a hazelnut; and from its fruit and wood is procured an essential oil of disagreeable odour, called *Huile de Gale*, which is used in veterinary practice, particularly as a cure for scab in sheep. — Virginian Juniper (*J. virginiana*), the Red Cedar of North America, is an evergreen tree, often 30–50 feet high, of conical form, with horizontal branches and very small leaves. The berries are small and bright blue. The heart-wood is of a beautiful red colour, valued by turners,

&c., while for cigar boxes and lead-pencils it has practically superseded the now scarce Bermudas Cedar (*J. bermudiana*), a lofty tree, with very fragrant reddish-brown wood.—The Himalaya Mountains produce several species of juniper trees of considerable size, beautiful appearance, and valuable wood.—The Swedish juniper of British shrubberies is merely a variety of the common juniper. The Savine which is *J. sabina*, is separately treated. See SAVINE.

Junius, LETTERS of, a series of seventy letters signed Junius, which appeared in the *Public Advertiser* between the 21st of January 1769 and the 21st of January 1772. They were revised by the author, and reprinted two months later in two small volumes by Henry Sampson Woodfall. An edition which appeared in 1812 contained one hundred and thirteen letters in addition to the seventy in the author's edition; five only of the one hundred and thirteen were signed Junius, and one of the five, dated 21st of November 1768, was the first which appeared with that signature. Soon after Junius began to write he attracted attention owing both to his apparent familiarity with current politics and notable persons, and to his boldness in commenting upon them, the climax being reached by him in his letter to the king on the 16th of December 1769. Woodfall was prosecuted for printing and publishing it in the *Public Advertiser*, and acquitted on a technical point, while Almon, a bookseller, was punished for selling a reprint of it. The audacity of Junius in bidding George III. remember that 'while the crown was acquired by one revolution, it may be lost by another,' stimulated public curiosity as to the writer of that letter and others. Burke was generally supposed to be Junius till his denial was accepted as conclusive. Among the many supposed authors of the letters were Lord Shelburne, Barré, Lord George Sackville, Wilkes, Home Tooke, and Thomas, Lord Lyttelton. It was not till after the publication of the edition of 1812 that the name of Sir Philip Francis (q.v.) was publicly affirmed to be concealed under that of Junius. John Taylor was the first to advance what is now known as the Franciscan theory. He wrote two books on the subject; the first appeared in 1813, and was entitled *A Discovery of the Author of the Letters of Junius*; the second in 1816, and was entitled *The Identity of Junius with a Distinguished Living Character Established*. In the first Taylor argued that the letters were from the pens of Dr Francis and his son; in the second, that the son was the sole author. De Quincey, Earl Stanhope, Lord Macaulay, and other critics and historians of note have accepted the Franciscan theory. Taylor was led to frame it by reading a letter which had appeared in the *Public Advertiser* on the 23d of March 1772 signed Veteran, in which Lord Barrington is charged with expelling Francis from the War Office. The 'Memoirs' of Sir Philip Francis by Parkes and Merivale appeared in 1867, containing private letters from Francis in which he wrote that he had resigned his clerkship and declined promotion to a higher post in the War Office, and that he was on terms of cordial intimacy with the Lord Barrington whom Veteran vilified. The extant manuscripts of Junius are said to have been written in a disguised hand, and many fancied resemblances have been traced between it and Francis's natural hand. Woodfall, the printer of the *Public Advertiser*, Tomkins, the principal writing-master of his day, and other contemporary authorities considered the handwriting of the manuscripts to be not only natural, but to bear a close resemblance to that of many men and women who lived when Junius wrote. Moreover, it was not till half a century after the publication of Junius's own edition of his

letters that the theory of a disguised handwriting was started in order to get over the difficulty that the natural hand of Francis was unlike that of the Junian manuscripts. No direct or indisputable proof has yet connected Francis with Junius. The authorship of the letters signed Junius remains a mystery. Junius was not the only important political writer of his time, many others being conspicuous and admired, yet the letters of Wilkes and Horne Tooke, to name those of two popular writers, were neither so uniformly brilliant, nor were they so carefully polished, as the letters signed Junius. This great anonymous writer set a pattern for the leading articles, which were unknown in his day, and through which newspapers now influence public opinion.

See *Junius* (2 vols. 1772); *Junius, including Letters by the same Writer under other Signatures* (3 vols. 1812); the articles on 'Junius' in Dilke's *Papers of a Critic*; articles in the *Athenium* by the present writer; Chabot and Twistleton, *The Handwriting of Junius* (1871); and H. K. Francis, *Junius Revealed* (1894).

Junk, a Chinese vessel, clumsy and incapable of much seamanship or speed; yet junks have proved themselves seaworthy on voyages extending even to America and Europe.—*Junk*, in the British navy, is a familiar term for the salt meat supplied to vessels for long voyages—the name being probably derived from the fact that it becomes as hard and tough as old rope, pieces of which are officially styled *junk*.

Junker, WILHELM, traveller, was born of German parents resident in Moscow in 1840, and studied medicine in Göttingen, Berlin, and Prague. Proceeding to Africa in 1874, in the first instance to Tunis and Egypt, he in 1876-78 carried through a series of explorations among the western tributaries of the Upper Nile, going as far south as the Kibbi, a feeder of the Welle. In the year following (1879) Junker started from Cairo on his second and more important journey, his object being to explore the basin and course of the river Welle-Makua, which he followed down to 22° 47' 40" E. long, and 3° 13' 10" N. lat. This river was eventually (end of 1887) proved by Captain Van Gèle to be identical with the Ubangi, a right-hand affluent of the Congo. After spending four years among the Moubutu and Niam-Niam, Junker prepared to return home, but was prevented from getting back to Egypt by the Mahdi's revolt, and had to remain with Emin Pasha and Casati. But in the end of 1886, a favourable opportunity presenting itself, he managed to find his way to the coast through Karagwe, and reached Cairo again in January 1887. He died at St Petersburg, 13th February 1892. See his *Reisen in Africa, 1875-78* (Vienna, 1889; English translation by A. H. Keane, 1890).

Junkers, the name commonly given to the younger members of the squirearchy or landed gentry of Prussia and the adjoining states.—*Junkertum* was a term of reproach used in the middle of the 19th century to designate the party of reaction in Prussia, which found its most strenuous supporters amongst the landed gentry.

Juno was to the Roman the abstraction of womanhood as Jupiter was the abstraction of manhood. This is the genuine Roman conception of Juno, and to this we must look and not to any nature-myth for the explanation of this deity. As Mommsen has said (*Hist. of Rome*, i. 28), what distinguishes Roman religion from Greek is that in the former 'to everything existing, to man and to the tree, to the state and to the storeroom, a spirit was assigned, which came into being with it and perished along with it, the counterpart in the spiritual domain of the physical phenomenon; to

the man the male genius, to the woman the female Juno.' This is the first point to notice in analysing this deity; Juno is the counterpart in the spiritual domain of the female principle in the human world. The next step in the analysis is indicated again by Mommsen: 'In occupations even the steps of the process were spiritualised; thus, for example, in the prayers of the husbandman there was invoked the spirit of following, of ploughing, of furrowing, of sowing, covering-in, harrowing, and so on, to those of in-bringing, up-storing, and opening of the granaries.' Following the indication thus given us we observe that every step in the life of woman, every function of the female principle, was spiritualised by the Romans, as is shown by the various titles given to Juno—e.g. *Virginensis*, *Matrona*, *Natalis*, *Juga*, *Jugalis*, *Curitis*, *Domiduca*, *Heiduca*, *Unxia*, *Pronuba*, *Cinxia*, *Fluonia*, *Ossipaga*, *Opigena*. These spiritual counterparts of the various phases of woman's life were, we may assume, probably not originally all supposed to inhere in one individual deity, but were separate and independent. And here we come to the third step in our analysis; these various spirits—the spirits of marriage, of birth, of travail, &c.—came eventually to be regarded not as separate spirits but as various manifestations of one and the same deity. What, then, was the thread round which these ideas so to speak crystallised? It was in all probability the figure of the Greek Hera. This undoubtedly became known to the Romans through the cities of Magna Græcia at an early period; the 'female Juno' became identified with her; the various attributes of *Virginensis*, *Matrona*, &c. were naturally assigned to the new, anthropomorphic Juno; and the other resemblances between Juno and Hera were loans effected at this and later times by the Romans from the Greek. Juno as she appears in Virgil is, of course, a reproduction of the Hera of Homer. See *HERA*.

Junot, ANDOCHÉ, Duc d'Abrantès, one of the great Napoleon's generals, was born October 23, 1771, at Bussy-le-Grand, in Côte-d'Or, entered the army as a volunteer in 1792, and distinguished himself in the early wars of the republic. His courage at Toulon caught the eye of Napoleon, and he carried him with him to Egypt as adjutant. At Nazareth he covered himself with glory by putting to flight as many as 10,000 Turks with but 500 horse. In 1804 he was made governor of Paris, and, after a short stay as ambassador in Lisbon, was appointed in 1807 to the command of the army for the invasion of Portugal. In a short time by his rapidity and skill he made himself master of all the strong places in the kingdom. For his brilliant success he was created Duc d'Abrantès, and appointed governor of Portugal; but he squandered the fruits of his victory by his absurd prodigality, and was ere long so severely defeated by Wellington at Vimiera that he was obliged to conclude a convention at Cintra and retire from Portugal. He subsequently served in Germany and Russia, and was made one of the scapegoats for the great Russian disaster, and sent to govern Illyria. This, added to the effect of former wounds in the head, brought on mental derangement. He was taken to his father's house at Montbard, near Dijon, and, two hours after his arrival, precipitated himself from a window, July 22, 1813, fracturing his thigh-bone. Amputation was performed, but Junot frantically tore off the bandages, and died seven days afterwards.—His wife, LAURETTE DE SAINT-MARTIN-PERMON (1784-1838), the accomplished and recklessly extravagant Duchesse d'Abrantès, gained a reputation in the literary world by her *Mmoires* (18 vols. 1831-35), and by several minor works.

Junta ('assembly'), the name given in Spain to a body of persons combined for political or administrative purposes, whether summoned by the sovereign or meeting on their own initiative as representatives of the people. The most famous is the central junta of 1808, with its provincial juntas, chosen for the conduct of the war with France.—In English history the Whig *junto* was the name given to the chiefs of that party in the reigns of William III. and Anne. The Junta was also the name of a debating society founded by Benjamin Franklin, which developed into the American Philosophical Society in 1743. Here also may be mentioned the interior committee of the privy-council under Charles I., which was the germ of the modern cabinet, and which Clarendon says was reproachfully called the *Juncto*. Its principal members were Laud, Strafford, and Cottington, the Chancellor of the Exchequer; the others were Juxon, the Lord High Treasurer, the two Secretaries, Vane and Windebank, the Marquis of Hamilton, and the Earl of Northumberland 'for ornament.'

Jupiter, the chief god of the Romans. Etymologically identical with the Sanskrit *Dyaus*, the Greek *Zeus*, and the Teutonic *Tiu* or *Zio*, Jupiter is one of the few gods that can safely claim to be descended from the Indo-European primeval period, and consequently one of the few exceptions to the rule that, if a deity is common to the Greeks and the Romans, he was borrowed by the latter from the former in historical times. But though Jupiter was known to the Italians from the time when they first became a separate branch of the Indo-European people, it would be an error to imagine that everything that can be predicated of the Greek *Zeus* holds good of the Roman god, or that the attributes of Jupiter can be ascribed indiscriminately to the Greek deity. We do indeed find that the same tales are told about Jupiter by Virgil and Ovid as had been related about *Zeus* by the Greek poets whom the Roman writers imitated; but it by no means follows that these tales were known to the Italians before their contact in historical times with the Greeks. On the contrary, it is in some cases perfectly certain that the myths were borrowed by the Romans from the Greeks. For instance, no myth in which Apollo figures along with Jupiter could possibly be an original Italian production, because it was only in historical times that the worship of Apollo was introduced from Greece into Italy. In this article, therefore, we must refer the reader for all that regards the Greek god to the article *ZEUS*. But, although we propose here to confine ourselves to the Roman deity, it is by no means easy to determine the outlines of this figure in mythology as it appeared to the religious consciousness of the Italians before they came in contact with Greek thought. We have but little direct information as to the Italians of that period. A few of the *indigitamenta* or formulae containing the epithets of the gods which were recited as a sort of litany by the Roman priests have survived to us, but not enough for our purpose. We are therefore reduced to general considerations. And from this point of view there is no reason whatever for assuming that the resemblance between Jupiter and the Greek *Zeus* was originally any greater than that between Jupiter and the Sanskrit *Dyaus* or the Gothic *Tiu*. As long as it was an accepted theory that the ancestors of the Greeks and Romans dwelt together, and apart from the rest of the Indo-European family, for some time before immigrating into their respective historical abodes, the case was different.

Now, however, this Pelasgian theory no longer has the sanction of either philology or archaeology. We must, therefore, conceive the difference between

the original Italian Jupiter and the Greek *Zeus* to have been determined by the general differences between Greek and Roman religion. In the striking words of Mommsen (*History of Rome*, i. 28), 'As the Greek, when he sacrificed, raised his eyes to heaven, so the Roman veiled his head; for the prayer of the former was vision, that of the latter reflection.' The Greek gods were thoroughly anthropomorphic; they were represented by their poets and their sculptors alike in the image of man. The gods of the Romans were much nearer the earlier stage of animism; they were powers whose good-favour could be propitiated and ill-will averted by the proper ritual and by sacrifice, but they were not subjects for plastic art until the time of Greek influence. This difference will at once account for the fact that no myths whatever attach to the Italian Jupiter—all that are related of him were borrowed in late times from the Greek *Zeus*. What we do find is that various epithets, such as *Lucretius* and *Elieius*, *Imbricitor*, *Prodigialis*, *Depulsor*, &c., are applied to him. And we may conjecture that all such epithets were probably, as some certainly were, originally part of the *indigitamenta*, with the recital of which the Roman priests sought to secure the favour of the god. In the next place it is to be noted that these epithets tend to show that Jupiter was originally to the Roman just as abstract a figure as *Janus* ('the spirit of opening'), *Juventus* ('the spirit of youth'), or *Foreulus* ('the spirit of doors'), *Limentinus* ('the spirit of thresholds'), or *Cardea* ('the spirit of door-hinges'). And we may conjecture that the Romans, who have retained the original Indo-European word for priest (*flamen* = Sansk. *brahman*) which the Greeks lost, also present to us the original animism of the Indo-Europeans more faithfully than does the anthropomorphism of the Greeks. That Jupiter was to the Italians, as to the Indo-Europeans, the spirit of the sky, is shown by his epithet *Lucretius*, which occurred in the *Salarie Hymns*. The same conception is at the bottom of the epithets which designate Jupiter as the spirit of thunder or of lightning—*Jupiter Tonans*, or *Fulgur*. As *Jupiter Latiaris* he presided over the Latin alliance. As the supreme spirit apparently he was besought to grant victory in war, and hence the names *Stator*, *Feretrinus*, *Victor*. The vintage also stood under the care of *Jupiter Liber*. The *Ides* of every month were sacred to him. He was also the spirit of oaths, *Dius Fidius*. Finally, although many of the epithets applied to him can at once be recognised as appropriate to the original character of Jupiter as spirit of the sky, such as *Elieius*, *Fulminator*, *Pluvius*, *Imbricitor*, *Serenator*, *Almus*, *Fugiferus*, there are others, such as *Stator*, *Victor*, &c., which cannot possibly be derived from his functions as a sky-spirit, and which must therefore be accretions, possibly resulting from the identification of the Roman Jupiter with the chief gods of the various allied states. The epithet *Capitolinus* is derived from the temple on the *Capitol* built by *Tarquin*, and the spirit inhabiting that temple was, compared with the rest, *Jupiter Optimus, Maximus*.

Jupiter. See PLANETS, and SOLAR SYSTEM.

Jura (Scand. *deor-ø*, 'deer-isle'), an Argyllshire island, $\frac{1}{2}$ mile N.E. of Islay, and $2\frac{1}{2}$ miles W. of the nearest point of the mainland. It extends 28 miles north-eastward; varies in width from $\frac{3}{4}$ mile, at *Loch Tarbert* in the middle, to $8\frac{1}{2}$ miles; and is 143 sq. m. in area. The western side is rugged and desolate, the eastern green and pleasing. The conical *Paps of Jura* are 2571 and 2412 feet high; and most of the surface is deer-forest. Pop. (1831) 1312; (1891) 619, nearly all Gaelic-speaking. See HEBRIDES and CORRIEVEKIN.

Jura, a range of mountains of a peculiar limestone formation, oolitic in composition, and generally called Jurassic, which extends from the angle formed by the Rhone and the Ain, in a north-easterly direction (with a gradually declining elevation) for more than 450 miles, to the upper course of the Main. But it is usual to restrict the name to the ranges that lie along the frontier of Switzerland and France—mainly in the departments of Doubs, Jura, and Ain. These constitute a plateau about 155 miles long by 40 wide, with an average height of 2000 to 2500 feet. The loftiest peaks are Roculet (5643 feet), Crêt de la Neige (2653), Mont Tendre (5512), and Dole (5507). The eastern face is much steeper than the western. The ranges are broken by numerous transverse gorges or 'cluses.' Many roads and railways traverse the chains, some of them of great strategic importance. Limestone caves are numerous, and they abound in magnificent stalactites and in the bones of extinct animals. Some rivers of considerable size sink into the ground and reappear after some distance, as the Orbe, the Doubs, and the Creuse. Fine pine-forests are a characteristic feature of the scenery.

Jura, an eastern French department, bounded on the E. by Switzerland. Area, 1928 sq. m.; pop. (1881) 285,263; (1891) 273,028. The slopes of the Jura Mountains are thickly wooded, but have also many pastures and meadows. At the foot of the Jura come rich vine-lands. The river-valleys are devoted to the cultivation of grain crops of various kinds. The chief rivers are the Doubs, Ain, and Ognon. The vines yield 62 million gallons of wine annually. The principal industries are the working of iron, cheese-making, watch-making, and turnery. Iron, salt, marble, clay (for pottery), and turf are the most important minerals extracted. The department is divided into four arrondissements, Lons-le-Saunier, Poligny, Sainte-Claude, and Dole. Capital, Lons-le-Saunier.

Jurassic System, the name given to that great series of Mesozoic strata which includes the Lias and overlying Oolites. The system receives its name from the Jura Mountains, where strata of that age are well developed. In England Jurassic rocks extend over a large area in Yorkshire between the mouth of the Tees and Filey Bay, and stretch south from the Humber along the western borders of the great flats of Lincoln and Cambridge, from which they sweep south-west as a broad belt across the Midlands to the Bristol Channel and the coasts of the English Channel between Lyme Regis and Durdlestone Head. Only a few patches of Jurassic rocks occur in Scotland, as near Brora on the east coast of Sutherland, and in some of the western islands. In Ireland the system is equally sparingly represented, as near Lame and Portrush in Antrim. On the Continent rocks of the same age are developed over extensive regions. They form a ring or zone-like belt surrounding the Cretaceous and Tertiary deposits of the Paris basin, underneath which the Jurassic strata doubtless continue. Farther south another belt sweeps round the central plateau of France, and stretches south to the Mediterranean. The most continuous areas in Germany occur in Franconia, Swabia, and Upper Silesia. Rocks of the same age occupy a wide region in central and northern Russia, while more or less isolated areas are met with in the Caucasus, the Crimea, the Carpathians, the Dinaric Alps, the Apennines, &c. One of the most important Jurassic tracts is that of the Jura Mountains, extending between Basel and Geneva. Narrow and broader belts of the same strata occur along the northern and southern flanks of the Alps. The

system also occurs in considerable force in the north-east and the south of Spain.

The Jurassic system of Europe has been arranged in the following groups:

PERMIAN: mostly of fresh-water origin; they contain traces of old land-surfaces (lirt-beds), with roots and stems of fossil plants.

PORTLANDIAN: chiefly sandstones, marls, and limestone (Portland-stone); marine.

KIMERICIAN: dark shales and clay (Kimeridge Clay); marine.

CORALLIAN: limestones with corals (Coral Rag), clays, and calcareous grits; marine.

OXFORDIAN: dark gray or blue clay (Oxford Clay) and calcareous sandstone (Kellaway's Rock—Callovian); marine.

BATHONIAN: limestones, clays, and sands (Cornbrash, Bradford Clay, and Forest Marble); shelly limestones (Great or Bath Oolite), Stonesfield Slate; Full's Earth; all marine.

BAJOCEAN (or Inferior Oolite): calcareous sandstones and grits (Cheltenham); marine; represented in York-shire by estuarine sandstones, shales, and limestones, with seams of coal and ironstone.

LIASSIC: sands and clays (Upper Lias) resting on limestones, sands, clays, and marls (Middle Lias, Marlstone); below which come limestones and dark shales (Lower Lias); all marine.

In India (Cutch) Jurassic strata, ranging from the Bajocian up to the Portlandian inclusively, attain a considerable thickness. The system is not largely developed in North America (Sierra Nevada and Rocky Mountains), but is notable in Colorado for its remarkable reptilian remains. Finally it may be added that Jurassic rocks have been detected in Spitzbergen, Siberia, Australia, New Caledonia, and New Zealand.

Life of the Period.—The predominant forms among the land-plants were cycads, conifers, ferns, and equisetums, but with these were associated true monocotyledonous angiosperms, represented by fossil fruits which are apparently referable to our screw-pines (Pandaneaceæ). This vegetation was widely spread over the earth's surface, flourishing abundantly in Britain, and extending far into the Arctic Circle.

The lower classes of the animal kingdom were represented by foraminifera and sponges, by a great variety of corals, by erinoids (both stalked and free forms), by starfishes, sea-urchins, &c. Corals are especially numerous, and mostly belong to the reef-building family of star-corals. Many of the limestones of the period, indeed, particularly those of the Corallian, are simply old coral reefs. Amongst erinoids one of the most characteristic forms was *Pentamerus*—a genus still living. Many genera of sea-urchins occur (*Aerosalenia*, *Cidaris*, *Diadema*, &c.), and with these were associated numerous starfishes and brittle-stars. The most prominent crustaceans were long-tailed decapods, to which belong our modern lobsters, prawns, &c.; and true crabs were also present. Insects were represented by ancestral forms of cockroach, grasshopper, earwig, ant, dragon-fly, may fly, beetles, bugs, &c. Brachiopods, which formed so characteristic a feature in the life of the Palæozoic seas, had now ceased to be dominant forms, although they were still individually numerous. Most of the old Palæozoic types had disappeared before Jurassic times two surviving forms (*Spirifer* and *Leptæna*) dying out at last before the close of the Liassic stage. We note, however, the presence of the inarticulate types (*Crania*, *Lingula*, *Discina*) which appeared first in Cambrian times and still flourish in our seas. The most important Jurassic brachiopods are *Terebratula* and *Rhynchonella*, of which there were many species. Both genera have survived to the present, but are represented by only a few species. Amongst the lamelibranch molluscs many forms unknown in Palæozoic times now made their first appearance, the most important types being the oysters (*Ostrea*, *Gryphæa*, and *Exogyra*), together with *Trigonia* and *Pholadomya*. Gastropods were fully numerous, and comprised

representatives of the whelks, spindle-shells, spider-shells, &c. of existing seas; and it may be noted that the earliest recognisable fresh-water univalves (*Laludina*, *Planorbis*) date from Jurassic times. But the most characteristic molluscs of this period were the cephalopods, both tetrabranchiate and dibranchiate types. The former, or chambered division, were represented by many forms of Ammonites, several hundred species having been chronicled; and the latter, or 'cuttle-fish' division, by numerous species of Belemnite. Among fishes were ganoids, usually of small size, and representatives of the sharks and rays. But by far the most important of the vertebrates were the reptiles, which flourished in extraordinary abundance during Jurassic times, and may well be said to be the most striking and characteristic life-forms of the period. Chelonians or turtles, lacertilians or lizards, and crocodiles are all represented; but the most characteristic reptiles were the huge sea-saurians, *Ichthyosaurus* (q.v.), *Plesiosaurus* (q.v.), and *Pliosaurus* (q.v.). Another remarkable group of reptiles were the pterosaurs or winged saurians, of which the most noted was *Pterodactylus* (q.v.). Contemporaneous with these were great Dinosaurs (q.v.), such as *Ceteosaurus*, *Megalosaurus*, *Atlantosaurus*, &c., while bird-life was represented by the toothed *Archæopteryx* (q.v.), with its lizard-like tail. The highest forms of life were small marsupial mammals, some of which seem to have been insectivorous, while others were herbivorous.

Physical Conditions.—During Jurassic times the area now occupied in the British Islands by the older rocks appears to have been for the most part dry land. The sea covered the north-east corner of Ireland, and extended along the west coast of Scotland over the site of what is now Skye, and it seems in like manner to have occupied the North Sea opposite the east coast, a portion of which in Sutherland was covered by it. What are now the high grounds of northern England and Wales and the heights of Devon and Cornwall, together with a ridge of Palæozoic rocks which extends under London, were the chief land-areas in south Britain, so that nearly all England was under water in the earlier stages of the Jurassic period. The same sea swept over vast areas of what is now the European continent. The older rocks in the north-west and north-east of France and the central plateau of the same country formed dry land—all the rest was submerged. In like manner, wide regions in Spain were under water. In middle Europe the sea covered nearly all the low grounds of north Germany, and extended far east into the heart of Russia, whence it passed north, and was doubtless confluent with the Arctic Ocean. It occupied the site of the Jura Mountains, and passed eastwards into Bohemia, while on the south side of the Alps it spread over a large part of Italy, extending eastwards so as to submerge a broad region in Austria-Hungary and the Turkish provinces. In short, what are now the central and southern portions of our continent formed a great archipelago in which appeared numerous islands large and small. The chief land-areas of the European region, therefore, were confined to the north and north-west. The existence of this northern land is shown by the fact that, while the Bajocian of the south of England consists of purely marine accumulations, the contemporaneous deposits in Yorkshire are largely fresh water and estuarine.

The Jurassic strata, which attain a thickness of several thousand feet, point to considerable subsidence; the downward movement, however, was not continuous, but seems to have been interrupted by pauses. Taken as a whole the strata of north-western and central Europe are indicative

of rather shallow-water conditions; but the waters were often sufficiently clear to favour the abundant growth of coral-reefs. After the deposition of the Portlandian beds the sea disappeared from what are now the low grounds of England. The succeeding Purbeckian beds are for the most part of fresh-water origin, and seem to have been laid down at or near the mouth of some large river, which probably took its rise in the hills of England or Wales, and flowed south across the upraised bed of the Jurassic sea. Similar indications of a more or less abrupt change from sea to fresh water are afforded by the Jurassic of central Europe, as in northern France, Hanover, Westphalia, and the Jura in Switzerland. While the Jurassic of central and north-western Europe would seem to have accumulated in somewhat shallow seas, the contemporaneous strata of the Mediterranean basin have a decidedly more pelagic aspect. This southern development of the Jurassic is sometimes called the Tithonian series. It is recognised in the southern Alps, the southern Tyrol, the Venetian and Dalmatian Alps, and the Carpathians, and extends into northern Africa.

The climatic conditions of the Jurassic period appear to have been extremely genial. Reef-building corals, for example, flourished in latitudes which are now some 3000 miles north of the present range of reef-builders, while cuttle-fishes and Ammonites and large enaliosaurians lived far within the Arctic Circle.

Jurieu. See DORPAT.

Jurieu. PIERRE (1637–1713), a French Protestant divine, studied at Sedan and Samur, received Episcopal ordination in England, and after some years of the pastorate, became professor at Sedan. On the revocation of the Edict of Nantes (1685) he became pastor of the Walloon church at Rotterdam, where till his death he busied himself in interpreting the Apocalypse and in defending the Protestant faith alike against Arnault, Bossuet, and Bayle.

Jurisdiction. in Law, means the authority which a court or judge has to entertain a particular case and decide it. The general rule is, that if a court which has no jurisdiction to decide a particular case does decide it, the judgment is a mere nullity. Jurisdiction may be limited either locally, as in the case of a county court; or personally, as where a court has a quorum; or as to amount, as when the Court of Session in Scotland takes cognisance only of cases above the value of £25; or as to the nature of the questions to be determined, whether crimes or civil actions. Jurisdiction is said to be concurrent or cumulative when it may be exercised in the same cause by any one of two or more courts at the choice of the suitor. In criminal procedure, to prevent the collision which might arise from each of the courts claiming to exercise the right, it has been established as a rule that the judge who first exercises jurisdiction in the cause acquires a right, *jure preventionis*, to judge in it exclusive of the others. This right of prevention plainly appears to be peculiar to criminal jurisdiction. In civil process it is the private pursuer who has the only right of choosing before which of the courts he shall sue (see INTERNATIONAL LAW). Jurisdiction is said to be privative, on the other hand, when the court having jurisdiction is the only court entitled to adjudicate in such cases. When a judge appoints another person to act in his place as deputy or substitute he is said to delegate his jurisdiction.

Jurisprudence is the science of law which professes to discuss the principles on which legal rights should be protected and enforced; or it may be called the philosophy of law. In its literal

sense the term means merely knowledge of the law, and seems to have been so used in the Roman law, from which it has been borrowed. The word is often used in a popular sense in Britain as synonymous with law, and it is also so used in France; but it is more correctly used in contradistinction to law, as implying the system or supposed methodical scheme embracing the principles on which positive law is founded. The Institutes of Justinian define jurisprudence, with a certain pomposity, as being the knowledge of things divine and human, the science of right and wrong. A distinction is sometimes made between general jurisprudence, which investigates the principles common to various systems of positive law, divesting these of their local, partial, and other accidental peculiarities; and particular jurisprudence, which confines itself to the particular laws of any country, say England, or France, or Scotland, as an independent system taken by itself. Jurisprudence thus embraces a wide range, as treating of all those duties which are enforced between man and man; and yet it may be safely said that lawyers, though dealing with the results of the science every day of their lives, seldom give any attention to the latent and general principles on which these results are founded. The science has been cultivated rather by students of philosophy than by lawyers; and the distinctive colours of the characteristic philosophies of England and Scotland have tinged the jurisprudence of the several countries. The utilitarianism of Locke and Mill has given a practical or empirical character to English jurisprudence, which may be seen in the legal works of Hobbes and Bentham, and at its hardest in the 'cast-iron' system of Austin, whose lectures were long the first English authority on this subject. In Scotland, on the other hand, a constant tradition of another tendency has been maintained among scientific jurists since the time of Lord Stair. Scottish jurisprudence has always had a closer affinity with the systems of the philosophical writers of France and Germany, and bases its conclusions upon the law of nature rather than upon experimental comparisons of varying systems of positive law. It is developed in the works of Ferguson, David Hume, Adam Smith, Dugald Stewart, and Professor Lorimer. The recent tendency of scientific jurists in England has been to abandon the empirical methods of treatment for the historical method, of which the most prominent and successful follower was Sir Henry Maine. In his work the elementary principles of jurisprudence are drawn from a study of the history of legal conceptions and institutions as they appear in remote ages and among peoples at a primitive stage of civilisation.

Jury, a body of private citizens, sworn to try a question of fact, or to assess the amount of a payment legally due. In almost all systems of law the ordinary citizen or freeman is called to take some part in the administration of justice. The *judices* of Roman law are sometimes compared with modern jurymen; and the *juror* was in fact a private citizen, empowered to try questions of fact and law under the general directions of a superior magistrate. In communities of Teutonic origin, and especially in England, the people, i.e. the qualified freemen, or a selection from their number, performed many important duties in civil disputes and criminal trials. They acted as assessors, to 'present' offenders against the law; they decided what action should be taken on a proof by witnesses, compurgators, or ordeal; they were themselves witnesses to the acts by which a title to land was established; even sales of goods were, in old time, witnessed by a kind of jury of townsmen. Many persons suppose that trial by jury, in the

modern sense, is as old as King Alfred; and a cartoon in the Houses of Parliament embodies this popular belief. Dr Stubbs (see his *Constitutional History*, chap. xiii.) attaches great importance to the popular element in the ancient courts; but he traces the modern jury system to a Frankish origin. Inquiry by sworn recognitors, as described in the Frank Capitularies, may have been adopted in part from the Roman imperial legislation. Introduced into England by the Norman Conqueror, this form of inquiry was developed into trial by jury under the influence of the Plantagenet kings and their legal advisers. In course of time the 'juratores' ceased to be regarded as witnesses, or as judges of law and custom; they acted on proofs laid before them, and they took the law from a presiding judge. The partisans of royal prerogative would have gone further; they would have deprived the jurymen of their independence, and compelled them to find the verdict dictated by the judge or the advisers of the crown. After a long struggle the independence of the jury was vindicated; while at the same time the judges were freed from subservience to the crown; the functions of judge and jury were accurately distinguished; and the rules of evidence were developed into a rational system. Trial by jury is prized as one of the chief safeguards of the liberties of the subject; it is admitted to be the best mode of trial in criminal cases of importance, and in those civil cases where damages may have to be assessed for wrongs which affect the person, family, or reputation of the plaintiff. In ordinary mercantile cases the tendency in England is to dispense with juries; the adjustment of property rights is also left, for the most part, to the judges. In political cases special importance attaches to the rules of law which secure the selection of a fairly representative jury. It is not possible under modern law to pack a jury with partisans of the government. In those parts of Ireland where popular feeling is hostile to the government, counsel for the crown have been frequently charged with making an unfair use of their right to order a juror to 'stand by' when his name is called; but it may be well to point out that jurymen are liable to be intimidated by the people, in cases in which party feeling is deeply aroused in Ireland, and that the democratic spirit is not always favourable to an impartial administration of justice in any country.

In the modern criminal practice of England and Ireland several forms of jury are in use. The Coroner's Jury consists of twelve men, usually householders, summoned by a peace-officer acting under the coroner's warrant, to inquire in cases of sudden death, &c. If their inquisition, or recorded verdict, charges any person with crime, the person accused must be arrested and brought to trial. The Grand Jury is a body of not less than twelve and not more than twenty-three men, summoned by the sheriff to consider the indictments to be preferred at assizes, quarter sessions, or the Central Criminal Court. They hear only the witnesses for the prosecution; if they think the evidence wholly insufficient, they 'ignore' the indictment, and the foreman indorses it with the words 'no true bill.' If they think there is a case which the accused ought to answer, they find 'a true bill,' and the accused is thereupon arraigned before a Petty Jury, who inquire whether he is guilty or not. The petty jury consists of twelve men, householders or owners of property, whose names are called over from the panel, or parchment list prepared by the sheriff. The prisoner may challenge the array, i.e. he may allege that the panel is unfairly made up. He may challenge peremptorily thirty-five jurors in a case of treason, twenty in a case of felony; and either the crown or the

accused may challenge any number of jurors for cause shown. When twelve men have been sworn, counsel and witnesses for the prosecution and defence address themselves to the jury; the judge interposes to decide points of law, or to remind counsel or witnesses of their duty; at the close of the trial he sums up the evidence, and states clearly to the jury the question they have to decide. If the jury retire to consider their verdict an officer is sworn to keep them 'without meat, drink, or fire;' but the judge may allow them to have a fire and reasonable refreshment. The verdict of the jury must be unanimous; and it is, generally speaking, conclusive: the prisoner cannot be tried again on the same charge. Common jurors do not receive any remuneration. On an indictment or criminal information for libel Fox's Act, passed in 1792, empowers the jury to find a general verdict on the whole matter in issue. The judges, in certain political cases, had directed the jury to find the defendants guilty on proof of publication of the paper charged to be a libel; and the act closes the last stage in the struggle for the independence of juries in criminal cases.

Civil cases which come before a judge and jury may be tried by a common jury of twelve men, whose names are called from the sheriff's panel, as in criminal cases. Both parties have the right of challenge to the array, or to the name of an individual juror, for cause shown. Either party may demand a special jury—i.e. a jury chosen from a special list, in which are entered the names of persons possessing a property qualification higher than is required in the case of common jurors. Special jurors are paid; the payment is usually at the rate of one guinea for each case. The jury must be unanimous; but the verdict of a majority may be taken by consent of the parties. If the case is compromised a juror is withdrawn by consent, and the case comes to an end. In the county court small civil cases are sometimes tried by the judge and a jury of five. For the use of the term jury in connection with manorial courts, see **MANOR**.

In Scotland forty-five jurors are summoned in criminal cases, of whom fifteen are chosen by lot to try the case; the verdict of a majority suffices. The crown and the accused have each five peremptory challenges; and any number of jurors may be challenged on cause shown. In some points the position of the accused is better than in England. He is entitled to have a copy of the indictment, a list of the witnesses to be brought forward against him, and a list of the jurors—advantages which an English prisoner has no legal right to demand, unless he is accused of treason or misprison of treason. Evidence is first given on both sides; the counsel for the prosecution then addresses the jury, and the prisoner's counsel speaks last. In England the prosecuting counsel may reply if evidence is given on behalf of the accused; and the Attorney-general or Solicitor-general claims the right to reply, even if no such evidence is given. Again, the jury in Scotland may find the charge 'not proven;' and this verdict is so far final that the prisoner cannot be put on his trial a second time on the same charge. This rule gives the accused an additional chance of escape; but there is something to be said against the expediency of permitting a verdict which leaves the question of guilt or innocence undecided, and allows the accused to go free without clearing his character. Trial by jury in civil cases was no part of the ancient practice of the Court of Session—it was introduced in 1815 by an act which adopted most of the English rules. As in England, the jury in civil cases consists of twelve persons; but unanimity is not essential. If, after being kept three hours in deliberation, nine or more of

the jury agree on a verdict, their verdict is taken as that of the jury. If, after being inclosed nine hours, the jury cannot agree, the judge is entitled to discharge them, and generally does so. The judge may allow the jury refreshment after they are locked up to deliberate.

In Ireland the jury laws are substantially the same as in England. Until the passing of the Act of 1871 (Lord O'Hagan's Act), 34 and 35 Vict. chap. 65, modified by 39 and 40 Vict. chap. 21, by which the empannelling and summoning of juries is made the subject of more stringent provisions, the law in England and Ireland was precisely similar. But special legislation has from time to time withdrawn from the consideration of juries in Ireland for a limited period certain crimes of an agrarian or 'quasi-political' character in times of great national excitement. By the Crimes Act, 50 and 51 Vict. chap. 20, special power, extending as high as that of imposing sentences of six months' imprisonment, on conviction of certain specified offences, were conferred on specially constituted magisterial courts sitting without a jury. And special juries for the trial of criminal charges may be empannelled in certain cases.

The Grand Jury in Ireland was till 1898 entrusted not only with the ordinary criminal business performed by the grand jury in England, but also with the entire local government of the country, county by county, much as the same was formerly carried on in England by the justices in Quarter Sessions; but the Irish Local Government Act of 1898 withdrew all its administrative functions, and conferred them on County Councils elected triennially. The authority of the Irish grand juries dated from Anglo-Norman times; and laws, custom, and tradition of 700 years were summed up and ascertained only in 1836 by the Irish Grand Jury Act.

In the United States English principles have been adopted; and trial by jury is made part of the constitution in most of the states. There are some states in which the jurors are empowered to decide questions of law in criminal cases, and in some the judge is forbidden to charge the jury on the facts. A verdict can be returned only on the unanimous vote of a jury; and, with a view to securing impartiality, each juror is required to swear that he is free from any preconceived opinion as to the case on trial, and has no information calculated to influence his decision. The law permits the challenging of individual jurors, both peremptorily and for cause; and this right has frequently been grossly abused for the purpose of delaying justice, as, for example, on the trial of the murderers of Dr Cronin at Chicago (1889). The British colonies have framed their jury laws, for the most part, on the English model.

Jury trial has been established in France (where the verdict of a majority is sufficient), and in many other continental countries, in most of which the institution will be found to bear a general resemblance to the English jury. There are, of course, endless differences in detail. For the particular rules as to qualifications of jurors, &c. in England, reference may be made to Archbold's *Practice* and Stephen's *Digest of Criminal Procedure*.

Jurymast, a temporary spar, used to replace a mast which has been lost from any cause, and so to enable the vessel to reach some port for more permanent repair.

Jus Devolutum, a phrase of ecclesiastical law used to denote the right of a church to present a minister to a vacant parish if the patron neglect to exercise his right within the legal time. In the Established Church of Scotland, if a cure be vacant by death or otherwise, a fit person must

be presented to the presbytery to supply the cure within six months after the occurrence of the vacancy. If no appointment is made in this time by the congregation the right of presentation accrues to the presbytery, and is called *jus devolutum*.

Jus Gentium. See INTERNATIONAL LAW.

Jus Mariti, a phrase used in Roman law, and adopted in the Scotch law to denote the legal right accruing to a husband *qua* husband over his wife's property. See HUSBAND AND WIFE.

Jus Primæ Noctis, the right of detraction of virgins, granted on the occasion of a marriage to a special person, as a chief or a priest, among many savage races, as the Kinipetu-Eskimo, Caribs, and certain Brazilian tribes. We have accounts by early travellers describing the custom as existing in Nicaragua, Teneriffe, Cambodia, Malabar; and Sugenheim asserts that the French kings Philip VI. and Charles VI. could not, in the 14th century, induce the Bishops of Amiens to give up the ancient right. Among many savages a similar privilege is freely granted to all the guests at a wedding—perhaps a survival of a reward for help in the abduction, although Lubbock ingeniously attempts to explain it as originally an act of expiation for individual marriage. Again, a period of privileged and unlimited license just before marriage is not uncommon; while we often meet with the practice of lending a wife or a daughter to a stranger from primitive notions of hospitality. Dr Karl Schmidt in his erudite work, *Jus Primæ Noctis, eine geschichtliche Untersuchung* (Freiburg, 1881), contends that this 'droit du seigneur' never existed in Europe, having left no evidence of its existence in laws, charters, decretals, trials, or glossaries, and that the later belief in it is merely 'ein gelehrter Aberglaube,' which has arisen in various ways, as from reports of individual cases of tyranny and from an unnecessarily gross interpretation being attached to the fine paid by the vassal to his feudal lord for permission to marry. Bachofen, Girard-Teulon, and Kulischer regard the *jus primæ noctis* accorded to a special person as a survival from a primitive stage of promiscuity or communal marriage, the ancient communal right being in course of time taken away from the community and transferred to the priest, king, or noble, as its chief representative. It is perhaps more simply to be understood as a mere tribute that may be exacted as a right by superior power, as by the kings of Dahomey; or a supreme mark of loyalty or respect offered to a chief or priest. This alleged ancient seigniorial privilege is the central point of Beaumont and Fletcher's odious play, *The Custom of the Country*.

Jus Relictæ, in Scotch law, is the right of a widow to a share in the movable or personal property of her deceased husband. See HUSBAND AND WIFE, SUCCESSION.

Jussieu, DE, the name of a French family which, for a century and a half, numbered among its members some of the first botanists of the age.—ANTOINE DE JUSSIEU, born at Lyons, 6th July 1686, and died at Paris, 22d April 1758, was professor of Botany and director of the Botanical Garden at Paris, wrote various works on botany, and edited Tournefort's *Institutiones Botanice* (1719).—His brother, BERNARD DE JUSSIEU, born at Lyons, 17th August 1699, and died in Paris, 6th November 1777, contented himself with assisting Antoine and his son without seeking renown by the publication of his own observations. In 1758 he was named superintendent of the gardens at the Petit-Trianon, and there arranged the plants in accordance with a natural system substantially the same as that which his nephew Laurent subsequently elaborated in a more perfect manner.

He edited the second edition of Tournefort's *Histoire des Plantes qui croissent dans les Environs de Paris* (2 vols. 1725).—ANTOINE LAURENT DE JUSSIEU, born at Lyons, 12th April 1748, died at Paris, 17th September 1836, the nephew and pupil of Bernard, was appointed professor of Botany at the Paris Botanical Garden in 1770. His *Genera Plantarum* (1789) laid down the principles on which modern botanical classification is based (see BOTANY). On the outbreak of the Revolution the hospitals of Paris were put in his charge. In 1793 he organised the library of the Muséum, one of the best in Europe. In 1826 he resigned his professorial chair to his son Adrien. He published numerous papers on botany in *Annales du Muséum* (from 1801-20), and in *Dictionnaire des Sciences Naturelles*.—ADRIEN DE JUSSIEU, son of Laurent, born at Paris, December 23, 1797, died in the same city, June 29, 1853, succeeded his father in 1826. On taking the degree of M.D. in 1824, he presented as his thesis a valuable memoir on the Euphorbiaceæ. This was followed by equally useful papers on the Rutaceæ, Meliaceæ, and Malpighiaceæ, and a memoir on the embryo of the Monocotyledons. His *Cours Élémentaire de Botanique* (1842) reached a 12th edition in 1884. A number of able botanists of all nations owed their training to him.

Juste, THÉODORE, a Belgian historian, was born at Brussels, 11th January 1818, became in 1839 keeper of the Museum of Antiquities there, and in 1870 professor of History, and died 11th August 1888. Juste was a voluminous writer, but many of his works are of considerable value for the history of his country. He is best known by his *Fondateurs de la Monarchie Belge* (27 vols. 1865-81). Many of his earlier works (1830-80) are abridged in *Le Pantheon National* (1881).

Juste Milieu, a French term, signifying the *just mean*, or, according to the common expression, the *golden mean*. After the revolution of 1830 this term acquired a political signification, and came into very frequent use, because of the declaration of the organs of Louis-Philippe, that the *juste milieu* was the only principle of government which could secure the welfare of France.

Justice, HIGH COURT OR, one of the two great sections of the English supreme courts, as arranged by the Judicature Acts (q.v.). For the Scottish College of Justice, see COURT OF SESSION.

Justice, LORD CHIEF, the title given to the chief judge of the Queen's Bench Division of the High Court of Justice; formerly given also to the chief judge of the Common Pleas. He of the Queen's Bench was, and still is, Lord Chief Justice of England; and on him were conferred, in 1881, the powers of the Lord Chief Justice of Common Pleas, that division of the court being abolished. Puisne (i.e. lesser or ordinary) judges in all divisions of the High Court bear the title of Justice, and are spoken of as 'Mr Justice Smith,' &c.

Justice-general, LORD, the highest judge in Scotland, also called the Lord President of the Court of Session (q.v.). Next to him ranks the Lord Justice clerk. See JUDICIARY COURT.

Justice of the Peace. In 1264 the name *custos pacis* appears for the first time in English history. Until the thirty-fourth year of the reign of Edward III. the officers appointed in each county to maintain internal order were invariably described as guardians or conservators of the peace. Originally royal nominees, the conservators of the peace were after the fifth year of Edward I. chosen (at least occasionally) by the whole community in the county court, under the instructions of the king conveyed by the sheriff. But after the deposition

of Edward II. the appointment of special *custodes pacis* was obtained by parliament (1 Edward III. stat. 2, chap. 16). The right of election thus taken away from the people was soon vested in, and has ever since been exercised by, the sovereign. While the power of appointing justices of the peace now practically belongs to the Lord Chancellor, it must be clearly understood that the commission of the peace is in theory the Queen's commission, and that the Lord Chancellor has no such authority over justices of the peace as he possesses over judges of the county courts. The functions of the *custodes pacis* appointed in 1327 were rapidly and widely extended by subsequent legislation; and 36 Edward III. stat. 1, chap. 12, gave for the first time to the old *custodes pacis* their familiar modern name. In 1590 a new form of commission was agreed upon, in which all the particulars formerly specified from a number of statutes were comprehended in words of general description. This was presented to the chancellor, accepted, sealed, and with slight variations has continued in use ever since. Under Richard II. justices of the peace attending quarter sessions were entitled to 4s. a day, payable out of the fines and amerciaments at such sessions. It appears, however, that these payments were often made out of the emoluments of the sheriff, and they were abolished. The office of justice of the peace has since been entirely gratuitous; but, after the conversion of the constabulary into police, stipendiary magistrates exercising a summary jurisdiction not unlike that of the justices have been appointed in all large cities and in many large towns. The office of justice of the peace seems to have been held on several occasions by a lady.

It is impossible here to trace minutely the history of the multifarious duties which have at different periods been discharged by the justices of the peace. The statute 11 Henry VII. chap. 3, enabled them to determine all offences except treason and felony without a jury upon information in the king's name. But this act was repealed in the first year of the reign of Henry VIII. In 1653, when the Barons' Parliament made marriage a purely civil contract, justices of the peace were empowered to hear the mutual declarations of the contracting parties. They were authorised by their commission, and still have power, to receive information with regard to any indictable offence. They were also invested with important administrative functions, such as the licensing of ale-houses and the appointment of overseers of the poor or surveyors of highways; and as local authority they transacted the chief county business, controlled the county police, and levied the county rates. The summary jurisdiction of justices of the peace has, however, been defined and restricted by recent legislation, and the Local Government Act of 1888 has transferred to the new county councils most of the administrative powers formerly exercised by the county justices in quarter sessions. See COUNTY, and QUARTER SESSIONS.

There are two classes of justices of the peace—those exercising jurisdiction within counties, and those appointed for boroughs. Under the Municipal Corporations Act, 1882, sect. 158, borough justices have no authority to act at general or quarter sessions for the county. County justices, on the other hand, have *primo facie* concurrent jurisdiction within any borough which forms part of the county. This presumption is, however, repelled where the borough charter contains an express clause to the contrary—called a *non intrumitter* clause—and the borough has its separate court of quarter sessions. Again, in the case of borough justices no special qualification beyond that of residence in or within seven miles of the

borough is required. But a county justice must have an estate of freehold, copyhold, or long leasehold in England or Wales of the clear annual value of £100, or a reversion expectant on leases for lives of £300 a year. By 38 and 39 Viet. chap. 51, it has now been further provided that a person shall be deemed qualified to be appointed a county justice who, being of full age, has for the space of two years immediately preceding his appointment been the occupier of a dwelling-house assessed to the inhabited-house duty at a value of not less than £100, and shall have been rated to all rates and taxes in respect of such premises. No sheriff can act during his shrievalty as justice of the peace for the county in which he is sheriff; and no person can be appointed to act during bankruptcy. The office of justice of the peace, being conferred by the crown, subsists only during the pleasure of the sovereign. The commission appoints all the persons named therein to keep the peace in the county specified, and any two or more of them to inquire of and determine offences committed in such county; in which number some particular justices with legal or special qualifications were formerly directed to be always included, and no business was to be done without their presence. The words of the commission ran *quorum aliquum vestrum A, B, C, D, &c. nunc esse volumus*; and the persons so named were called justices of the *quorum*. It is now, however, the practice to include nearly all of the justices in the *quorum* clause.

The functions of justices of the peace are partly administrative and partly judicial. The former, which were exercised at *special sessions*, used to embrace a great variety of subjects, but since the Local Government Act, 1888, sect. 3, are now practically restricted to the licensing of ale-houses and the appointment of overseers of the poor. The control of the police in counties will henceforth be undertaken by a joint committee of the county council and of the justices in quarter sessions. The latter fall into three classes. (1) The justice of the peace, like the ancient *conservator pacis*, is empowered to preserve the peace, to suppress riots and affrays, to take security for good behaviour, and to order the apprehension and committal of criminals. (2) At *petty sessions* the justices are enabled to try certain minor offences summarily and without a jury. (3) The commission of the peace authorises any two or more justices to hear and determine certain graver and indictable offences at *quarter sessions*. The statute 34 Edward III. chap. 1, confirming 18 Edward III. stat. 2, chap. 2, enabled justices of the peace to try at quarter sessions all felonies and trespasses whatsoever committed within the county. Comparatively recent legislation has expressly excepted from the jurisdiction of quarter sessions the most serious offences in the criminal law, such as murder, perjury, forgery, bigamy, abduction, &c., and only the smaller misdemeanours and felonies are now triable at these courts. The orders and convictions of justices out of sessions can be appealed against to quarter sessions; and an order made at quarter sessions may as a general rule be removed into the Queen's Bench Division of the High Court by writ of *certiorari*.

As to the liability of a justice of the peace, in the case of a justice acting erroneously within his jurisdiction, an action will not lie without an express allegation and proof of malice and want of reasonable or probable cause. In the case of a justice who either has no jurisdiction or exceeds it, no such allegation or proof is required, but no action can be brought in regard to a conviction or order till it has been quashed upon appeal. ☉

In Scotland the duty of collecting evidence for

the prosecution of criminals rested originally upon the justice-clerk and the sheriff. When it was proposed to hold a criminal inquiry, the sheriff, under the authority of a writ issued by the justiciar, summoned the best and most capable men of each burgh, town, and barony within his shire to appear before the justice-clerk and give information of the crimes done within their respective bounds. This being done, it lay with the justice-clerk to digest the materials thus returned to him, and to make up from them a roll of the offenders' names, and a file of dittay, or indictments for bringing those persons to justice. When the Scotch circuit system was reorganised, a more regular and effective method of taking 'dittay' was adopted; the act of 1587 empowered the king, on the advice of his chancellor, treasurer, and justice-clerk, to appoint 'honourable and worthy persons . . . in degree earls, lordes, barronnes, knights, and special gentlemen Landed, experimented in the lovable laws and customes of the realme, actual indwellers in the same shires . . . to be constant and continual up-takers of dittay.' This is the first statute dealing with the institution of justices of the peace in Scotland. The office was further regulated by acts in 1609, 1617, 1633, and 1661. The form of commission is practically identical with that which was settled for use in England in 1590. There is no property qualification in Scotland; but under 6 Geo. IV. chap. 48, sect. 27, a solicitor cannot be nominated a justice of the peace for any county in which he is practising. By 19 and 20 Vict. chap. 48, sect. 4, the disqualification does not extend to writers or procurators who may be elected magistrates or deans of guild in any burgh. The functions of justices are partly administrative and partly judicial. The Local Government (Scotland) Act, 1889, sect. 11, has transferred to the new county councils the powers and duties of the justices in relation to the following subjects: (1) the execution as local authority of the acts relating to gas-meters, explosive substances, weights and measures, habitual drunkards, and wild birds; (2) the appointment of visitors of public, private, or district lunatic asylums; and (3) the registration of the rules of scientific societies under 6 and 7 Vict. chap. 36. As in England, the justices have still authority in regard to the licensing of ale-houses, the administration of the poor laws, &c. The jurisdiction of justices of the peace is partly civil and partly criminal. In civil questions between master and servant they have jurisdiction to any amount. The justices can entertain applications for the alimony of bastard children. The civil jurisdiction of the justices is now practically superseded by that of the sheriff court, unless to the limited extent allowed by the Small Debt Act (12 and 13 Vict. chap. 34). There is no trace in Scotland of trial with a jury before justices of the peace, as in England at quarter sessions. The ordinary criminal jurisdiction of justices is confined to breaches of the peace, petty thefts, and trifling assaults, punishable by a small fine and imprisonment. A variety of penal statutes have conferred upon the justices of the peace jurisdiction in relation to the revenue, highways, fishings, and public-houses. In Ireland the justice occupies practically the same position as in England.

The institution of justices of the peace exists in the United States of America. In some of the states these magistrates are appointed by the executive, in others they are elected by the people and commissioned by the executive; in some cases they hold office during good behaviour, but as a general rule they are appointed for a limited period. See Bouvier's *Law Dictionary* and Poore's *Federal and State Constitutions*.

JUSTICES' CLERK.—The justices' clerk is an officer appointed by justices of the peace in England (who, although not themselves trained lawyers, are yet called upon to administer many branches of the law) to assist them in the discharge of their duties, to advise them as to points of law and practice, to take minutes of the proceedings in every case, to receive and transmit fines, &c. Every clerk appointed after the passing of the Justices' Clerks Act, 1877, unless he has previously held a similar appointment for a period of not less than fourteen years, is required (a) either to be a barrister of not less than fourteen years' standing, or a solicitor to the Supreme Court of Judicature, or (b) to have served for not less than seven years as a clerk to a police or stipendiary magistrate, or to a metropolitan police-court, or to one of the police-courts of the City of London. Under the same statute justices' clerks receive a fixed salary instead of deriving their remuneration, as formerly, from the court fees.

Justices, Lords. Since the Norman Conquest it has been the occasional practice in England for the sovereign to nominate one or more persons to exercise the chief powers of government during his temporary absence from the kingdom. At first this duty was imposed, principally although not perhaps exclusively, upon the justiciar. But when, after the death of Hubert de Burgh, the functions of the justiciar were gradually distributed and his office itself was practically abolished, *custodes regni* or 'lords justices' were appointed to govern the realm during the sovereign's absence. The English sovereigns from Edward VI. to James II. were never, while actually reigning, absent from England at all; and William III. in the early years of his reign invariably left Queen Mary to discharge the duties of viceroy when he went to the Continent. But after the death of Mary lords justices appear to have been appointed under the great seal, on the occasion of the king's absence, five times between 1695 and 1699. The names of the Archbishop of Canterbury and the Lord Chancellor were usually placed at the head of these commissions. The Act of Settlement (12 and 13 Will. III. chap. 2) provided 'that no person who shall hereafter come to the crown shall go out of England, Scotland, or Ireland without consent of parliament;' but this clause was repealed by 1 Geo. I. chap. 51; and George I. during five of his absences from England (1719, 1720, 1723, 1725, 1727) left lords justices to represent him. Similar appointments were made by George II. after the death of Queen Caroline; and George IV. on his visit to Hanover in 1821 delegated his authority to nineteen guardians, of whom the Duke of York, heir-presumptive, was one. During the reign of Victoria the propriety of an appointment of lords justices was twice considered on occasion of the royal visit to France, and in 1845, when the Queen was preparing to visit Germany; and on the latter occasion an interesting discussion took place in the House of Lords. The view taken by Lord Chancellor Lyndhurst was that, although the great seal could not be used out of the realm, mandates of the sovereign given by sign-manual out of the realm were valid, and that it was 'in the breast of the sovereign,' on going abroad, to appoint representatives or not, as might be deemed for the public good. This debate practically settled the question, and the nomination of lords justices has fallen into desuetude. These appointments were usually made by letters patent under the great seal, but in one or two cases parliamentary confirmation of the powers conferred by the king's authority was obtained.

The power to create peers has only once been

delegated—by Charles I. in favour of Lord Herbert, afterwards Earl of Glamorgan, in 1644.

Lords justices have sometimes been appointed to carry on the government of Ireland in place of a viceroy: but in modern times this has only been done during occasional absences of the lord-lieutenant, or in the interval between the demise of one lord-lieutenant and the appointment of his successor. These lords justices have usually been the Primate, the Lord Chancellor, and the Commander of the Forces.

LOURS JUSTICES OF THE COURT OF APPEAL.—In 1811 it was found that the work devolving on Lord Chancellor Eldon in the Court of Chancery, and at the same time as Supreme Judge of Appeal in the House of Lords, was too severe for his strength. After considerable discussion it was decided to appoint a new judge, under the title of vice-chancellor, to perform part of his duties; and in 1851 Lord John Russell introduced into the House of Commons a bill for the reform of the Court of Chancery. This statute (14 and 15 Viet. chap. 83) transferred the entire jurisdiction of the Lord Chancellor as head of the Court of Chancery to a new tribunal called the Court of Appeal in Chancery. The members of this court were the Lord Chancellor himself, and two other judges who were required to be at the date of their appointment barristers of not less than fifteen years' standing, took rank and precedence next after the Lord Chief-baron of the Exchequer, and were styled Lords Justices of the Court of Appeal in Chancery. Shortly afterwards the lords justices were 'entrusted with the care and custody of lunatics by warrant under the Queen's sign-manual.' The Judicature Acts established a new Court of Appeal (see APPEAL), in which there are four *ex officio* members—the Lord Chancellor, the Lord Chief-justice, the Master of the Rolls, and the President of the Probate, Divorce, and Admiralty Division—and five ordinary members, who are called 'lords justices' after their predecessors in the old Court of Appeal in Chancery. The lords justices are now merely members of the Court of Appeal, and have no original jurisdiction in the Chancery Division. Their jurisdiction in lunacy, however, remains substantially unaltered; and by section 51 of the Judicature Act of 1873 they were appointed additional judges of the High Court of Justice, so that they might exercise it more effectively, by the aid of all that original jurisdiction in Chancery which was formerly auxiliary to the jurisdiction in lunacy. The lords justices occasionally sit as additional judges of the High Court of Justice. When acting in this capacity they are bound by the judgment of a Divisional Court, even although they may disapprove of it, and would have reversed it in the Court of Appeal.

Justiciary Court, the highest criminal court in Scotland. Its judges are, since 1887, the judges of the Court of Session (q.v.); formerly there used to be but seven justiciary lords, five of them appointed by patent. It sits usually in Edinburgh, but also holds circuit-courts twice a year in a number of towns, four times at Perth, Dundee, and Aberdeen, and six times in Glasgow, the kingdom being divided for that purpose into three divisions or circuits. The jurisdiction embraces all crimes whatever; and it is an appellate court as regards inferior criminal tribunals. Its decisions are final, there being no appeal to the House of Lords.

Justifiable Homicide is the killing of a human being without incurring legal guilt, as where a man who has been duly sentenced is hanged; where one, in self defence, necessarily kills another to preserve his own life, &c.

Justin, surnamed the Martyr, one of the earliest and most distinguished apologists of the Christian church, was a native of Flavia Neapolis, the ancient Sichem, in Samaria. He was born probably near the year 100 A.D. His father Priscus was a heathen, and Justin was educated in the religion of his father. He became an ardent student of the philosophy of his age, beginning with the school of the Stoics, but finally adhering to that of the Platonists. His conversion to Christianity he ascribes in one place to the firmness of the Christian martyrs, in another to a chance meeting with a venerable stranger, who directed him to the study of the Jewish prophets, and though them to the great Christian teacher whom they foretold. After his conversion he retained the garb of a philosopher, and appears to have wandered from place to place, as we find him disputing at Ephesus and Rome, if not in other cities also. His martyrdom is supposed to have taken place some time between 148 and 165, but the story rests on no sure historical evidence. The works of Justin, although not very voluminous, are highly interesting and important. The only books ascribed to him with certainty are two *Apologies for the Christians*, the first (the date is a matter of controversy, and has been placed anywhere between 138 and 160) addressed 'to Antoninus Pius,' the second (perhaps an appendix to the first) 'to the Roman senate;' and a *Dialogue with Trypho the Jew* (date perhaps between 155 and 164), which professes to be the record of an actual two days' disputation held at Ephesus. These are extant in two MSS. only, which agree very closely with each other; one is at Paris (date 1364), the other (date 1541) in the Philipps Library at Cheltenham. The *Speech to the Greeks* is possibly Justin's; the other works once ascribed to him are certainly spurious.

The first edition of his works is that of Robert Stephens (Paris, 1551). The Benedictine edition of Justin, by Maran, appeared in 1742; and Otto's—the best—at Jena (3 vols. 1842-47; 3d ed. 1876 *et seq.*). There are good translations of Justin in the *Library of the Fathers* (1861) and Clarke's *Anti-Nicene Library* (1868), and a popular account in *The Christian Fathers*. See also monographs by Semisch (Ersolan, 1840-42), Aubé (Paris, 1875), Engelhardt (Erlang, 1878), and Bishop Kaye (new ed. 1888); and Donaldson, *Hist. of Christ. Lit. and Doctrines* (vol. ii. 1866).

Justin, a Roman historian who flourished, in all probability, in the 3d or 4th century, although some assign him an earlier date. His *Historiarum Philippicarum Libri XLIV.* is a selection, rather than an abridgment, from the *Historia Philippica* of Trognus Pompeius, a work now lost, and so called from its being in the first instance a history of the Macedonian monarchy, but really a kind of history of the world down to the Roman conquest of the East. There are editions by Dübner (1831), Hartwig (1860), and Rühl (1886).

Justin I. and II. See BYZANTINE EMPIRE.
Justinian I. Flavius Anicius Justinianus, nephew, on the mother's side, of the Emperor Justin, was born in 482 or 483 A.D., in the village of Tauresium, in Illyria. His original name was Flauda. Although of obscure parentage, the son of a Slavonic peasant, he shared the success of his maternal uncle, Justin, being invited at an early age to Constantinople, where he received a careful education. When his uncle assumed the purple in 518 he appointed Justinian commander-in-chief of the army of Asia. His tastes, however, inclining him rather to civic pursuits, he declined this appointment, and remained attached to the court of Constantinople. In 521 he was named consul, and during the remaining years of the reign of his uncle he continued to exercise great influence. In 527 the Emperor Justin, by the advice of the senate, proclaimed him his partner in the empire.

Justin survived this step but four months, and in the same year Justinian was proclaimed sole emperor, and crowned along with his wife, the famous Theodora, whom, despite of her more than dubious antecedents as an actress, he had raised to the position of his wife. Justinian, on his accession, was in his forty-fifth year. His reign, which extends over thirty-eight years, is the most brilliant in the history of the late empire. Although himself without the taste or the capacity for military command, he had the good fortune or the skill to select the ablest generals of the last days of Roman military ascendancy. Under the direction of his generals, and especially of the celebrated Narses (q.v.) and Belisarius (q.v.), his reign may be said to have restored the Roman empire, at least in outward appearance, to its ancient limits, and to have reunited the East and West under a single rule. In his first war—that with Persia—he concluded a treaty by which the crisis that had so long threatened was at least warded off; but the rejoicings which celebrated its termination had, owing to a domestic revolution, almost proved fatal to the authority of Justinian himself. A conflict of the so-called Blue and Green factions in the circus in 532 was but an outburst of political discontent, which went so far as to elect a rival emperor, Hypatius. Justinian himself was struck with dismay, and had made preparations for flight; but the vigour and determination of Theodora arrested the revolt. Narses, with a relentless hand, repressed the tumults, 30,000 victims having, it is said, fallen in a single day. By the arms of Belisarius, the Vandal kingdom of Africa was re-annexed to the empire; and the same general, conjointly with Narses, restored the imperial authority in Rome, in Northern Italy, and in a large portion of Spain. One of the most extraordinary, though in the end ineffectual works of the reign of Justinian was the vast line of fortifications which he constructed, or renewed and strengthened, along the eastern and south-eastern frontier of his empire. These works of defence, and the construction of many public buildings both in his capital and in other cities of the empire, involved an enormous expenditure, and the fiscal administration of Justinian, in consequence, pressed heavily on the public resources.

It is, however, as a legislator that Justinian has gained his most enduring renown. His good fortune in obtaining the services of able generals was not greater than that which attended him in the field of law and legislation. Brilliant as were the triumphs of Narses and Belisarius, they were indeed short-lived in comparison with the work done by the celebrated Tribonian (q.v.) and his coadjutors in the way of reforming and codifying the law. Immediately on his accession Justinian set himself to collect and codify the principal imperial *constitutions* or statutes enacted prior to, and in force at, the date of his accession. In this respect he followed the example set by his predecessor, Theodosian. The code in which these *constitutions* were collected was published in 528-29, and it contained a general provision by which all previous imperial enactments were repealed (see CODE). But Justinian's ambition in the matter of consolidating the laws went much further. Imperial constitutions made up but a comparatively small part of the body of the law. The bulk of it (what might be called the *common law*) was contained in the writings of the *jurists*—i.e. of text writers and commentators. Of these writings there were at this time many hundreds of volumes in existence, and, owing to want of agreement in the opinions of the various writers, the law was in a state of great uncertainty, not to say confusion. To remedy this evil Justinian resolved upon the publication of a single treatise in which

the commentaries and other writings of the jurists might be digested and harmonised. The preparation of this great work was entrusted to Tribonian, with the assistance of Theophilus, a celebrated professor of law at Berytus (modern Beyrout), and two other professors, and eleven advocates, and it was completed in the short period of four years. It was published in fifty books under the title *Digesta* or *Pandectæ* on 31st December 529. While the *Digest* was in course of preparation Justinian resolved on the composition of a third legal work—viz. a systematic and elementary treatise on the law which might serve as a textbook for the use of students and as an introduction to the larger work. The preparation of this was also entrusted to Tribonian and his colleagues, and having been completed a few days before the *Digest*, was published in four books on the same day (31st December 529) under the title of *Institutiones*. It is based upon the Institutes of Gaius, and is familiar to all modern lawyers under the name of 'Justinian's Institutes.' Meantime, while both the *Digest* and the *Institutes* were being prepared, the *Code* of 529 above mentioned was withdrawn from circulation and republished in 534 with some alterations, and especially with the addition of fifty new constitutions (known as the *Quinquaginta Propositiones*) which had in the interim been pronounced by Justinian. This new edition, in twelve books, is known as the *Code Repetitæ Prælectionis*, and is the one which has come down to us, no copy of the earlier codex being extant. All these works (*Code*, *Digest*, *Institutes*) were written originally in Latin, and all of them were prepared with care and skill, and testify to the great ability of Tribonian and his co-editors. Upon the publication of the *Digest* Justinian declared by a constitution that all previous law books and decisions were to be held as superseded, and it was forbidden to refer to them in the practice of the courts. During the subsequent years of his reign Justinian pronounced from time to time several new constitutions or laws, some of them making very important changes in certain departments of the law. These (mostly in Greek) were collected and published under the title of *Novellæ* (i.e. 'the Novels' or 'New Constitution'). There were, so far as can be ascertained, about 170 of these Novels. The Institutes, Digest, Code, and Novels together make up what is known as the *Corpus Juris Civilis*.

The character of Justinian has been much canvassed, and opinions are not agreed about it. Procopius, in two separate works, has painted him in very different lights. Making allowance, however, for much exaggeration of his abilities by contemporary writers, it may be said that he contrasts favourably with most of the emperors, whether of the earlier or the later empire. If his personal virtues be open to doubt (and certainly vanity, avarice, and inconstancy were in no small degree characteristic of him), he, on the other hand, displayed undoubted ability as a ruler, and in the main, just and upright intentions. He died on 14th November 565 at the age of eighty-three, and in the thirty-eighth year of his reign.

A few words must be said about the legislative reforms carried through by Justinian. He was not only a collector and codifier of the laws; he also introduced in many directions the most fundamental changes into the substantive law itself. The following were the most important changes: (1) He ameliorated the condition of slaves—depriving their masters of the power of putting them to death. He declared that any one who put a slave to death at his own hand should be guilty of homicide. (2) He greatly revolutionised the law of intestate succession by giving to *cognati* (relatives on the

mother's side) an equal share with *agnati* (relatives on the father's side) of the same degree. These two changes in the law were probably in a large measure induced by the circumstances of his birth. He made considerable changes in the law of divorce and as to the property of spouses, and he reformed civil procedure in the way of making it uniform, and introducing a system of small-debt courts.

See the *Life* by Isambert (Paris, 1856); by G. Body (6th ed. 1889); Newman, *Doctrines of Justinian* (4th ed. 1885); Roby, *Introduction to the Digest* (1884); Muirhead, *Roman Law* (1886).

Jute and Jute Manufactures. Some attempts on a small scale to utilize jute-fibre for the manufacture of carpets were made at Abingdon, in Oxfordshire, about the year 1820 or soon after it. But it was at Dundee, which had long been one of the principal seats of the linen industry, that, in 1832 or 1833, the spinning and weaving of jute first began to give promise of commercial success. The fibre, then little known in Europe, was at first received with suspicion, and for some years it was slowly and somewhat stealthily introduced as a textile material. By the year 1850,



Jute (*Corchorus capsularis*):
a, flower; b, fruit.

however, the use of jute had become extensive, and since then, owing, among other things, to the improvements in preparing and spinning machinery, the manufacture of this fibre has rapidly extended, and is now carried on at Dundee, the chief seat of the industry, on a gigantic scale. Jute cloth for Gunny-bags (q.v.) and for native clothing has long been woven on hand-loom in Bengal, where the plants yielding the fibre are cultivated. Since 1857 a number of large jute-mills, fitted up with textile machinery, driven by steam-power, have been erected in the neighbourhood of Calcutta. The comparatively small cost at which jute can be raised and manufactured will no doubt secure its permanent success as a textile industry; but the fibre is decidedly inferior to flax in strength and especially in durability.

Jute is obtained from the bark of two closely-allied species of plants belonging to the line tree order (Tiliaceæ). One species, *Corchorus capsularis*, is cultivated in central and east Bengal; the other, *C. olitorius*, is grown, but to a more limited extent, in the neighbourhood of Calcutta. The former grows from 5 to 10 feet, sometimes even to 14 feet, in height, but the latter is rather a smaller plant. The chief difference between the two is in the form of the fruit, which in *C. capsularis* is globular, and in *C. olitorius* much elongated. Both are annuals with yellow flowers, and they can be best cultivated on a loamy soil or upon one of clay and sand. The higher lands produce the finest qualities of jute. Such as is grown upon mud-banks or upon submerged lands is mostly larger and coarser. The sowing

time, which is regulated by the nature and position of the soil, extends from March to June. When the plants flower, which they do in some places in the end of June, the cutting of the crop begins, but this is often not done till the fruit is formed. The harvest is not entirely finished till October, and it is from late reaping, with the plants in seed, that coarse jute is obtained, the crop yielding the best fibre if cut during the flowering period.

The fibre, which is the inner bark, is separated from the stem by retting—i.e. steeping in water (see FLAX). Sometimes the jute is placed in rivers, but more generally in tanks or stagnant pools. To prevent any risk of discoloration of the fibre in the process the jute stalks in some districts are first stacked for a few days to allow the leaves to decay. According to the nature of the water used and the character of the crop, the period of retting lasts from two days to fully three weeks. Care must be taken to stop the process as soon as the fibre begins to separate from the stem, otherwise it rapidly deteriorates. It is believed that retting weakens the fibre, and that if it could be separated from the bark by some inexpensive mechanical process a better quality of jute than it is now possible to obtain would be sent into the market.

The best qualities of jute are of a pale clear yellow or buff colour, with a silky lustre, easily spun and comparatively strong. But there are at least half a score of well-known commercial varieties. Some are bright-coloured, soft, and strong, and such are best for textile fabrics—i.e. comparatively soft, for all jute is of a hard and woolly nature. Other kinds are coarse and strong, and suited for making ropes. One or two varieties which are of weak fibre are suited for making paper. One kind, which is long, soft, and fine, but of bad colour, is largely used for gunny-bags.

In order to lessen the harsh and brittle character of jute it is subjected to a softening process on a kind of crushing mangle, from cisterns attached to the top of which oil and water are at the same time sprinkled evenly upon it. Formerly whale-oil was used for this purpose, but of late years a heavy paraffin oil or some similar mineral oil has been largely substituted for it, a change which caused a great fall in the price of whale oil. The mangle consists of four horizontal rows of fluted rollers, 9 inches in diameter, between which the jute passes in a continuous layer, entering at one end between the first pair of the two upper rows, and coming out at the opposite end between the last pair of the two lower rows. Besides simply turning round, the rollers have also a slight lateral motion, so that the jute is thoroughly crushed or nipped. This crushing—together with the help of the oil and water—softens the fibre, and prepares it for the spinning processes.

Jute was formerly, and to a small extent is still, spun by two distinct processes, called 'line' spinning and 'tow' spinning, which correspond to those in use for flax. The main difference between them is that in 'line' spinning the fibre is hekkled on machines with hekkle-stocks furnished with steel teeth, which dress and separate the line or best part of the fibre from the tow, or least valuable portion. In the 'tow' spinning the fibre is first carded on carding-engines, each of which has a peculiar arrangement of revolving cylinders, armed with card points or pins of steel wire. What may be called the carding process of spinning is no longer confined to jute tow, but the whole of the jute is now, as a rule, spun on this system—i.e. it is not hekkled at all. Jute-fibre as obtained from the plant being from 6 to 7 feet long, and often considerably more,

it requires to be broken into lengths of from 14 to 18 inches. This is done on the machine called the breaker-card, upon which also the jute is cleaned and the fibres laid more or less parallel by the action of the card points. The jute leaves the breaker-card in the form of a continuous lap or sliver, 3 to 4 inches broad, and fifteen of these are drawn out and delivered as a single sliver by the second carding engine, called the finisher-card. This attenuation is accomplished by the doffing-rollers having fifteen times the surface speed of the feed-rollers.

The sliver, or rather slivers, are next taken to the *drawing-frame*, where their fibres are further straightened and equalised. The drawing-frame has feed-rollers, travelling gills with steel teeth, and drawing and delivery rollers. Here four slivers from the finisher-card are caught by the feed or retaining rollers, passed through the travelling gills, and drawn out into one sliver by the drawing-rollers, which, as well as the delivery-rollers, move at $4\frac{1}{2}$ times the speed of the retaining-rollers. The sliver from the drawing-rollers is, besides, usually doubled by passing two of them between the delivery-rollers. The process is repeated on a second drawing-frame with finer and closer teeth than those on the gills of the first. The object of doubling and drawing out the slivers so frequently is that the thick place of one sliver may be corrected by the thin place of another, and also that the different kinds of jute may be thoroughly mixed both as to quality and colour.

Roving is the next operation, and the *roving-frame* in the arrangement of its rollers and gills is similar to the drawing-frame, but in the former the parts are smaller and the gill-teeth finer and more closely set. As the sliver on this machine, after being still further attenuated by drawing-out rollers, requires to be twisted into a loose thread or 'rove,' a spindle and flier are provided, as well as a bobbin upon which to wind it. Finally the bobbins of 'rove' are taken to the *spinning-frame*, and spun into yarn upon the 'throstle' principle. See SPINNING.

Jute fabrics are for the most part woven of yarn retaining its natural colour. But for some purposes it is bleached, and when used for carpets or curtains it is dyed various colours. Although it can only be made pure white with difficulty, it readily bleaches pale enough to admit of its being dyed without injury even to bright colours. Dyes upon jute are, however, fugitive unless they are dyed by a special and expensive process, which is only carried out to a small extent in practice. At Dundee the ordinary fabrics made of jute are Hessians, sackings, carpets, tarpauling, and backings for floorcloth. The last-named are woven on looms of extraordinary width (see FLOOR-CLOTH). Dyed carpets, curtains, table-covers, and the like, of this material, are attractive enough in appearance, and carpets especially are largely made. These are cheap but not very durable. Millions of small, brightly-dyed prayer carpets for Moslems are sent from Dundee to the East. Fabrics made of jute are easily rotted by damp, and cannot be often washed and dried like linen or cotton goods without injuring them. This fault of jute soon betrays itself if it is mixed with flax for towelling. Jute, from its somewhat glossy lustre, is occasionally used to sophisticate silk; and it has been employed to some extent to make wigs and other articles in imitation of those made of human hair, chiefly for theatrical purposes.

The following calculation made by Indian commercial men in 1883, and quoted in Watt's *Dictionary of Indian Products*, gives an idea of the extent of the jute trade in different parts of the world. Of raw jute to supply its factories per week, Scot-

land (Dundee) required fully 18,400 bales, England 1860 bales, and Ireland 730 bales; total for the United Kingdom, 21,000 bales. France required weekly 4000 bales, Germany 2170 bales, and other European countries between them 2000 and 3000 bales. The annual consumpt in all Europe was then estimated at 321,400 tons, or 1,800,000 bales. There were actually shipped in the year 1882 83 to Europe 2,364,400 bales, but some may have been re-shipped. At that time the twenty-two Indian factories consumed yearly 107,000 tons, and other countries not included above (chiefly America and Australia) required another 107,000 tons. The total annual consumpt of raw jute in the world at that time was thus about 535,400 tons, the value of which may be roundly taken at 26,000,000. In 1892-98 the jute annually shipped from Calcutta fluctuated from 2,216,000 bales to 2,990,000 bales; and the price varied from £10 per ton to £13, 15s. In 1896, one of the years when imports were greatest, the total import was 340,649 tons, value £4,167,492; while of jute yarn there were exported from the United Kingdom 37,224,300 lbs., value £378,356, and of jute woven goods, 257,146,200 yards, value £2,269,692. Of British exports, three-fourths go to the United States, and an increasing quantity to Germany. Of 7190 textile manufactories in the United Kingdom in 1890, only 116 were jute-mills.

Dundee has no monopoly: Indian rivalry has become formidable. The number of Indian steam factories, mostly near Calcutta, was, in 1890, twenty-four, giving employment to 49,000 persons, and using up annually 143,450 tons of jute. From a comparative statement of the wages paid to six classes of work-people in a Dundee and in a Calcutta jute-mill, published in 1884, it appears that in Scotland they earn from one-half to two-thirds more than they do in India, with the exception of weavers, whose pay is more nearly equal in the two countries, and of unskilled labourers, whose wages are very small in the East. But it is said that to produce a finished piece of jute fabric seven persons in India are required to do as much as three at home. The classes of goods manufactured are, however, not exactly the same in both countries, and for this, as well as for other reasons, the comparison cannot be very accurately made.

The value of jute manufactures (yarns and woven fabrics) exported from the United Kingdom in 1894 was £2,423,913. The United States import annually some 20,000 tons of jute, besides 70,000 or 80,000 tons of jute-batts (lower part of stem and upper part of roots). The States may be said to pay \$10,000,000 annually for imported jute and jute goods, though the plant is now being grown successfully in the southern states, and though machinery is being developed with the view of rendering America independent of foreign jute.

Jüterbog, or JÜTERBOCK, a town in the Prussian province of Brandenburg, 39 miles by rail SSW. of Berlin. Cloth, cigars, and wine are manufactured. Pop. 6797. Near Jüterbog is Dennewitz, where the Prussians under Bulow defeated the French under Ney and Oudinot, September 6, 1813.

Jutland (Dan. *Jylland*), the only considerable peninsula of Europe that points directly north, has since early in the 10th century formed a portion of the kingdom of Denmark (q.v.). Area, 9754 sq. m.; pop. (1890) 942,120. Jutland is said to have been inhabited in the earliest times by the Cimbric (q.v.); hence it was called the Cimbric Peninsula or Chersonesus. In the 5th century it was inhabited by the Jutes, who took part in the expedition of the Saxons to England. The Jutes were succeeded by the Danes, who, under the name

of Normans (Northmen), frequently desolated the coast of Germany and France.

Juvenal. Decimus Junius Juvenalis was born about 55 A.D. at Aquinum, in the Volscian country, where his father, a free Roman citizen, possessed an estate. He received the usual rhetorical education in Rome, and became the friend of Martial, and at least the acquaintance of Statius and Quintilian. Probably under Titus, or early in Domitian's reign, he served as tribune in the army, and in his native town filled the important posts of censor and flamen of the deified Vespasian. We know from an inscription apparently written by himself that he was in Britain and returned home in safety, but there is no evidence that he was there in a military capacity. That he was in Upper Egypt is certain, but that he was banished thither by Hadrian is merely a more plausible conjecture than that he died an octogenarian under Antoninus Pius.

His interest for posterity depends altogether on his sixteen satires, still extant, which occupy the very first rank in satirical literature, and are of priceless value as pictures of the Roman life of the Empire. The order in which these compositions follow each other in the earliest manuscripts and latest editions seems to have been that in which they were originally published. They were grouped probably by Juvenal himself into five books, and these were given to the world at intervals, during which he seems to have undergone notable changes of mood. The first book contains the first five satires, and saw the light in the early years of Trajan's government. It presents Juvenal's powers at their highest and most sustained pitch, fresh from living experience of Domitian's brutalising sway, the forms and effects of which constitute their main theme. Book second consists of one satire, the sixth, levelled at females in general, of whom, in their degraded, unsexed condition under the empire, he draws a well-nigh savage picture, unrelieved by any touch of that chivalry which belongs to a later and christianised civilisation. By many (chiefly French and Italian) critics it is reckoned his *chef-d'œuvre*. It probably appeared a little before the death of Trajan. The third book was published soon after Hadrian's accession, and comprises the seventh, eighth, and ninth satires. Interwoven with passages of earlier composition than that date, these touch, without uniformly maintaining, the high level of the preceding ones. The fourth book, also published under Hadrian, is made up of the tenth, eleventh, and twelfth satires, and in the best of them, the tenth, on the 'Vanity of Human Wishes,' notwithstanding its fine declamatory swing and its characteristic misogyny, there is a softer spirit, as of the 'years that bring the philosophic mind,' or at least temper the impetuosity of earlier manhood. The fifth book, again given to the world in Hadrian's time, contains satires thirteen, fourteen, fifteen, and sixteen, and even more than its predecessor betrays the softening influence of age, while distinctly the least vigorous and effective of the series.

Juvenal and Horace respectively represent the two schools into which satire has always been divided; and from one or other of them every classical satirist of modern Europe derives his descent. As Horace is the satirist of Ridicule, so Juvenal is the satirist of Indignation. Juvenal

is not a man of the world so much as a reformer, and he plays in Roman literature a part corresponding to that of the prophets under the Jewish dispensation. He uses satire not as a branch of comedy, which it was to Horace, but as an engine for attacking the brutalities of tyranny, the corruptions of life and taste, the crimes, the follies, and the frenzies of a degenerate society. He has great humour of a scornful, austere, but singularly pungent kind, and many noble flashes of a high moral poetry. It should be noted that the old Roman genius—as distinct from the more cosmopolitan kind of talent formed by Greek culture—is plainly discernible in Juvenal. He is as national as the English Hogarth, who perhaps gives a better image of his kind and character of faculty than any single English humorist or moralist that we could name. Juvenal has been better translated in our literature than almost any other of the ancients. Dryden's versions of five of his satires are amongst the best things he ever did. Dr Johnson imitated two of the most famous in his *London* and *Vanity of Human Wishes*; and the version of the whole of them by Gifford is full of power and character.

The latest and best editions of Juvenal are those of O. Jahn (2d ed. by Bucheler, 1886), A. Weidner (Leip. 1889), and J. E. B. Mayor (Lond. 1878-86). Other annotated editions are those of Maclean, Lewis (with a literal prose translation), and Pearson and Strong.

Juvenile Offenders. In the eye of the law persons are considered capable of committing crime when of the age of seven, and are punishable like other persons. But in England and Ireland, whenever a person under the age of sixteen is convicted and sentenced to be imprisoned, the court or magistrates may also sentence him to be sent to a reformatory school for not less than two or more than five years. Such sentence, however, cannot be passed upon an offender under ten years of age, unless his offence is by law punishable with penal servitude or imprisonment, or unless the sentence come from a superior court, such as a court of assize or of quarter sessions. Children who have not yet committed crime, but are in a vagrant and neglected state, may also be sent to an industrial school.

Juxon, WILLIAM, one of the figures on the last 'memorable scene' of Charles I., was born at Chichester in 1582. From Merchant Taylors' School he passed to St John's College, Oxford, and succeeded Laud as its president in 1621. Already he had held livings at St Giles, Oxford, and Somerton in Oxfordshire, and through Laud's influence he became successively dean of Worcester, prebendary of Chichester, dean of the Chapel Royal, and Bishop of London. In 1635 also he was made Lord High Treasurer—a dignity, Laud writes proudly, 'held by no churchman since Henry VII.'s time.' In Charles's vacillation about the fate of Strafford, Juxon advised him to refuse his assent to the bill, 'seeing that he knew his lordship to be innocent.' He ministered to the king in his last moments, and it was into his hands that Charles delivered his Gorge with the word 'Remember.' During the Commonwealth Juxon amused himself with his pack of hounds at his country-house in Gloucestershire, and four months after the Restoration was appointed Archbishop of Canterbury. He died at Lambeth, 4th June 1663.

K

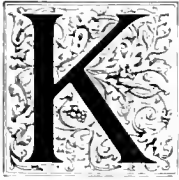

is the eleventh letter in our alphabet. The symbol was derived from the Egyptian hieroglyphic picture of a bowl (see ALPHABET). When taken over by the Phœnicians the letter was called *kaph*, 'the hand,' the two slanting strokes being probably supposed to represent the forefinger and the thumb. With little change of form or name it was transmitted to Greece as *kappa*, and then with the other Greek letters it passed into the primitive alphabet of Italy, where it was retained by the Umbrians and the Oscans, but ultimately discarded by the Etruscans and the Romans. That it belonged originally to the Latin alphabet is proved by its occurrence in two or three of the earliest Latin inscriptions, and by its retention in certain conventional archaic abbreviations, such as *KAL*, for *calendæ*. It was not used in classical Latin, since after the invention of *G* (see *G*) it was superfluous, the letter *C* having acquired precisely the same sound, that of the sharp guttural mute, which is formed by raising the tongue to the back of the palate. Hence this sound came to be denoted by *C* in the Latin alphabet and in all the alphabets derived directly from it, such as Italian, French, and Spanish; while the symbol *k* was retained in the alphabets which were directly or remotely influenced by the Greek, such as Coptic, Russian, Wallachian, Servian, Runic, Gothic, and German. Thus in French the letter *k* is only used in modern loan-words, such as *kopi*, or *Edouatre*; while in German *c* is confined, for the most part, to words derived from Latin or French, such as *criminal*, *ciel*, *consul*, or *canal*.

In England, where the two influences met and encountered each other, the usage is conflicting. In the southern or Saxon shires, into which the alphabet was introduced by Roman monks, *c* was at first universal, *k* being unknown before the 12th century. In the northern or Anglian shires, which possessed the runes, a script ultimately of Greek origin (see RUNES), *k* is found in very early MSS., such as the Rushworth Gospels. To the Northumbrian missionaries, to whom the conversion of Germany is chiefly due, may be attributed the use of *k* instead of *c* in the German alphabet. After the Norman conquest of England the phonetic power of *c* became uncertain, owing to the introduction of its French value of *s* in such words as *city*, and hence in the 12th and following centuries the use of *k* began to spread from the northern counties to the east midlands, and then to East Anglia, being employed in the first instance before the vowels *e* and *i*, where the value of *c* was most ambiguous. Hence in Middle English we find *k* in the words *Kent*, *ken*, *kath*, *ken*, *king*, *keep*, and *key*; and also before *a* in the words *kure*, *knee*, *kneel*, *knave*, *knot*, and *knave*, in all of which *c* had formerly been employed. It is also used in words of Scandinavian, Dutch, or northern origin, such as *ken*, *key*, *kud*, *kitt*, *kuttle*, *kirk*, *kippred*, *kink*, and in such modern loan-words as *Koran*, *knave*, and *kaleidoscope*. But on the

whole the usage in English accords more with Latin and French than with Greek, German, and Russian.

K², a Himalayan peak. See GODWIN-AUSTEN.

Kāaba (Arab., 'square house'), the name of an oblong stone building within the great mosque of Mecca. See MECCA.

Kaama, a large species of Antelope (q.v.).

Kabbala. See CABBALA.

Kabul, or CABUL (the Kabura of Ptolemy), a very ancient town which has figured prominently in modern history. It was taken in 1394 by Tamerlane, and again in 1739 by Nadir Shah, whose son Ahmed Khan founded the Durani dynasty. Timur made Kabul the capital of Afghanistan in 1774. It is memorable for the events which led to the terrible disaster of 1842 (see AFGHANISTAN). It was taken in September of that year by Pollock, and its bazaar was destroyed; after which it remained unvisited by Europeans till the year 1879, when Sir Louis Cavagnari was appointed Resident. The story of his murder is still recent history. On its capture by Sir Frederick Roberts the city was again held by a British force for a time; but after the instalment of the Amir Abdur Rahman on the throne, the British forces again evacuated Afghanistan in August 1880.

Kabul is charmingly situated at the foot of the Takht-i-Shah and Asmai hills which separate it from the Chardeh plain. On a spur of these hills south of the city is the fortress of Bala Hissar (or 'upper fort'), once an important stronghold, but now abandoned. The city, which is composed almost entirely of mud-built buildings with flat roofs, is traversed by the main bazaar, the streets of which diverge from the central square and divide the city into four quarters. The Kabul bazaar rivals that of Kandahar, and includes every variety of trade. Carpets, camel-hair cloth, and skins are perhaps the chief specialities; but there are now many shops in which European goods can be purchased, and Kabul is rapidly assuming the general character of an Indian mart. Roads have been improved and wheel traffic introduced, cultivation has been much developed, and new buildings added which greatly improve the city. Communication with India is now regular and constant, there is a growing trade with central Asia, and the Afghan policy of exclusiveness towards strangers has been greatly modified. The cantonment of Sherpur, situated about a mile north of the Bala Hissar, where the British troops were beleaguered in 1880, is maintained in good repair. Close to it are still to be traced the outlines of the old British entrenchment of 1840. At the western extremity of the Benara ridge, which flanks Sherpur on the north, is the English cemetery, now protected by a high wall and kept in fairly good order. Kabul is celebrated for its fruit, its grapes and melons being especially famous. The elevation of the plain above sea-level is about 6000 feet, which ensures a delightful temperature and fine climate in summer, but is sometimes severely cold in winter, when snow occasionally covers the ground to the depth of

several feet, and communication is frequently interrupted. The population of the city probably does not exceed 70,000, and it is composed of all the varied elements of Afghan nationality. Duranis (or true Afghans), Ghilzais, Hazaras, Tajiks, and Kizzilbashies form the chief Mohammedan part of the population, whilst Hindus are numerous in one quarter of the city, and a few Jews are also to be found.

The **KARL RIVER** rises at Sar-i-Chashma, near the source of the Helmund, flows through Kabul city, and, mainly by a long series of precipitous defiles, finally reaches the Indus at Atrok. The length of its course (generally south-easterly) is about 270 miles, and for the most part its volume is insignificant, although it sometimes floods the country about Naushera.

Kabyles, a branch of the great Berber race of North Africa. See **BERBERS**; also **ALGERIA**, and **TUNIS**.

Kadiak, an island off the S. coast of Alaska, separated from the mainland by Alaska Strait. It is mountainous and heavily wooded, contains good harbours, and has an area of 3465 sq. m. It is inhabited by a tribe of Eskimos, engaged in the salmon-fishery, and has a pop. of 1500.

Kampeviser. See **DENMARK (LITERATURE)**.

Kaf, the mountain which in Mohammedan legend surrounds the world.

Kaffa, or **FEODOSIA**, a seaport in the Russian government of Taurida, on a bay on the east side of the Crimea, 62 miles E. by N. of Simferopol. It is defended by walls and a citadel, and contains the ruined palace of the Khans of the Crimea and a Greek cathedral. Near by is an Armenian monastery (1442). Soap and caviare, camel-hair carpets, and sheep-skin rugs are manufactured; and here is the only oyster-fishery in Russia. The harbour is safe and spacious, but there is comparatively little shipping. Pop. (1891) 10,796.—The ancient Theodosia or Feodosia was a flourishing colony of the Milesians; in the 13th century the Genoese founded here a successful trade-depot, which they called Kaffa. It fell to the Turks in 1475, and to the Russians in 1792.

Kaffir Bread, a name given to several South African species of *Enecephalartos*, which, like many others of their order (*Cycadaceae*, q.v.), have much starch in their stems, and afford a kind of sago and a not nutritious bread.

Kaffir Corn. See **DURRA**.

Kaffirs (also spelt **Kafirs** and **Caffres**), a well-marked division of the Bantu family of the Negro race, inhabiting the districts now known as Swaziland, Zululand, the South African Republic, Orange Free State, Natal, the Cape Colony dependency of Pondoland, Griqualand East, Tembuland, and Transkei. They embrace two main divisions, the Zulus (q.v.) and the Kaffirs proper. The word 'Kaffir' is a corrupt form of the Arab 'Kafir,' meaning 'unbeliever,' and was borrowed from the African Mohammedans by the Portuguese, and from them by the Dutch and English. The Kaffirs proper never at any time formed one united race, but have always been split up into a number of tribes, the most influential of which have been the Ama-Temba, the Ama-Nosa (represented by the Gelekas and the Gaikas), and the Ama-Mpondo. Of these the first named are the tribe of royal blood, though the greatest power has always been in the hands of the Geleka chief. The Kaffirs are a fine, stalwart race of men, well made, muscular, and tall. Their skin varies in colour from light brown to sepia black. The racial characteristics depart more and more from the strict Negro type the further the

tribe lies to the south. Yet in all the nose is broad, the lips thick, and the hair woolly; but it does not grow in tufts, as is generally asserted. They are fond of decorating their persons with beads, shells, and feathers, and they protect their skins from the sun by rubbing them with fat and red clay, which makes them look like polished bronze. The women, upon whom devolves the hard labour of cultivating the fields, are individually of inferior physique to the men. The principal article of dress is a tanned ox-skin; but for this many have within recent years substituted a blanket. They live in beehive-shaped huts, grouped in kraals or villages. These huts are formed of strong wicker-work frames thatched with reeds and grass, the largest about 25 feet in diameter and 7 or 8 feet high in the centre. They are a pastoral people, the chief occupations of the men being stock-breeding and hunting; but in quite recent times the cultivation of the soil has begun to extend amongst them. The care of cattle is the most honourable employment, and belongs entirely to men. They formerly worked in both iron and copper, and were not unskilful in pottery and wood work. The principal articles of food are milk, maize, and millet. Youths are circumcised at fifteen or sixteen, living thereafter for a couple of months by themselves; the entrance into womanhood is marked by the *abonjane*, a dancing festival closing a period of seclusion. They practise polygamy, but the wives are not of equal rank, and cannot belong to the same tribal name as the husband. The custom known as *ukuhlonjane* prohibits females from pronouncing the names of any of their husband's male relatives in the ascending line, or any words whatever in which the principal syllables of such names occur—a usage which leads to the women using different words from the men almost to the extent of a different dialect. The three clicks of the Ama-Nosa, usually represented by the superfluous letters, *c*, *q*, and *x*, are easily sounded separately by Europeans, but are insurmountably difficult to the adult in combination. The religious instinct has never been very strongly developed amongst this people, and their rites consist merely in sacrifices to appease the malignant spirits on every hand. Their supreme being, Qamata, is indifferent to man, and is seldom invoked in prayer. Snakes are treated with great respect, being regarded as a favourite form assumed by ancestral spirits. The belief in witchcraft is deeply rooted, and the witch-doctor is generally a person of great influence in the tribe. The original fine moral qualities of the Kaffirs—hospitality, honesty, and truthfulness—have been greatly contaminated through contact with vicious Europeans. At the same time Christian missions have made considerable progress, and the well-known unsectarian mission settlement of Lovedale (opened 1841), so generously supported by the Free Church of Scotland, with its offshoot, Blythwood, 120 miles distant, in the Transkei, has already brought thousands of natives within the range of its influence. The Kaffirs have ever been notable for their bravery. In war they arm themselves with ox-hide shields, about 5 feet long, wooden clubs with heavy heads, and assegais. Politically they are organised in a number of tribes, each subject to a hereditary chief, whose power is supreme. Yet one chief was recognised as paramount of all the tribes.

Partly owing to the war-loving propensities of the Kaffirs, and partly to their cattle-lifting raids and disputes with the colonists about cattle, Kaffir wars have been frequent. In 1780 the Great Fish River was declared the boundary of Cape Colony to the east, but the Kaffir incursions became so troublesome that in 1810 it they had to be driven back behind the Fish River by force of arms.

After a similar little war, undertaken for a similar reason, in 1819, during which the Kafirs made an unsuccessful attack upon Graham's Town, the boundary was advanced eastwards to the Kat River. But peace was constantly being broken. In 1834 the first of the greater Kafir wars broke out, and lasted until the following year. But, although the enemy were repulsed and their territories up to the Kei River annexed by the colonial government, the annexation was not ratified by the home authorities until the termination of the next war (1846-48). The conquered districts were called British Kaffraria, and from 1853 to 1865 formed a separate crown colony; but in the last-quoted year British Kaffraria was incorporated in Cape Colony. The power of the chiefs was nevertheless still unbroken: in 1850 the turbulent Gaikas, who had waged most of the former wars, in conjunction with the rest of the Ama-Nosa and the Ama-Tembu tribes, and a large body of revolted Hottentots, once more invaded the colony, but after a struggle of nearly three years were successfully driven back. In 1856 the frontier districts were settled by the men of the German legion who had fought in the Crimea, nearly 2500 in number. The last war broke out in 1877: the Gelekas took up arms, and were joined by the Gaikas, and eventually the Zulus also entered the fray (see ZULUS). The war ended in the overthrow of the power of the Kafir chiefs, and the gradual incorporation of their territory in the Cape Colony. By 1888 all Kaffraria up to the frontiers of Natal, with the single exception of East Pondoland which, however, was a British protectorate—had been included within the bounds of the Cape Colony.

The Ama-Fengus, or Fingoes, are the remnants of broken Kafir tribes; they are despised by the organised Kafir races, and but for the protection of the British would probably be little better than slaves to them. They have always been loyal to their protectors, and live scattered from Zululand to Cape Colony.

See G. Fritsch, *Die Eingeborenen Süd-Afrikas* (1872); grammars of the Kafir language by Bleek (1869) and Colenso (1855); Chase and Wilmot's *History of the Cape of Good Hope* (1869); G. McCall Theal's *Kafir Folklore* [1882], and *History of South Africa* (1888); and G. de Rualle, *Les Peuples de l'Afrique* (1880).

Kafiristan, a mountainous region of Asia, lying between the Kabul River on the south and the Hindu Kush on the north-west: its eastern and western boundaries are formed by the Chitral and Panjshir rivers respectively, feeders of the Kabul. Area, about 5000 sq. m. This region of wild, narrow, winding glens and impassable mountains (11,000 to 17,000 feet) has been for centuries the last stronghold of primitive Aryan heathenism against the encroachments of Islam. It is on this account that the inhabitants are called by their Mohammedan neighbours Kafirs—i.e. 'unbelievers,' and their country Kafiristan. These people, about 200,000 in all, although speaking different dialects, are ethnically of one race. But they do not form a political unity; the tribes into which they are divided are often at war with one another. The only points of union between them politically are their hatred of the Mohammedans and their passionate love of independence. This they have successfully maintained at different times against such great conquerors as Mahmud of Ghazni, Timur, and Baber. The mountaineers are fair in complexion, the women often handsome. Contrary to the custom of orientals, they do not sit cross-legged on the ground, but sit on stools; and they shake hands like Englishmen. Their dress is made of goat-skin and goat's hair. They are fond of wine and dancing. Cultivable soil exists only

in small patches alongside the torrents; consequently the people follow chiefly pastoral pursuits. Since 1893-95 Kafiristan is recognised by Britain as under Afghan control, and it is now garrisoned by the Amir's troops.

See Leitner's *Kafiristan* (Lahore, 1881); Tanner in *Proc. R. G. S.* (1881); M'Nair in same (1884); Eddulph, *Tribes of the Hindu Kush* (1880); Sir G. Robertson, *The Kafirs of the Hindu Kush* (1896).

Kagoshi'ma, a town of Japan, on a large bay of the same name, at the south end of Kiu-siu Island, with manufactures of pottery and porcelain, arms, and cotton. Pop. (1896) 55,197. It was bombarded by the British fleet in 1863.

Kaictour Fall. See ESSEQUIBO.

Kai-fung, capital of the Chinese province of Honan, near the southern bank of the Hoangho, where the great inundation occurred in 1887, long the chief settlement of the Jews in China. Among its 100,000 inhabitants are many Mohammedans.

Kailás. See ELLORA, INDUS.

Kain, an old term in Scotch law, used to denote rent paid in kind, as in the shape of poultry or animals, to a landlord.

Kainite, a hydrated compound of the chlorides and sulphates of magnesium and potassium, used as a fertiliser. See MAGNESIUM, MANURE.

Kainozoic. See CAINOZOIC.

Kaira, capital of a district in northern Gujarat, 20 miles SW. of Ahmedabad by rail. Pop. 12,640.

Kairwan, a decayed walled town of Tunis, in an open, marshy plain, 80 miles S. of the capital. It contains about fifty ecclesiastical structures, of which the mosque of Okba, who founded Kairwan about 670, is one of the most sacred of Islam. Outside the city, to the north-west, is the mosque of the Companion—i.e. of the Prophet; this and other sacred tombs have rendered Kairwan—i.e. 'caravan or resting-place—the Mecca or sacred city of northern Africa. As such, it has been jealously guarded from defilement by the presence of Jews and for the most part of Christian travellers; but it was entered and exploited by the French in 1881. Kairwan makes copper vessels, potash, carpets, and articles in leather. Pop. 15,000. See E. Raw, *Country of the Moors* (1877); Boddly, *To Kairuan the Holy* (1885).

Kaisarich. See CESAREA.

Kaiserslautern, or LAUTERN, a town of the Bavarian Palatinate, 52 miles by rail SW. of Worms, has of late years developed into an important manufacturing place. The chief manufactures are tissues, yarn, sewing and other machines, ultramarine, furniture, beer, bricks, &c.; and there are ironworks, steam-sawmills, and railway shops. Pop. (1875) 22,690; (1890) 37,047. Frederick I. built a castle here in 1152 (destroyed by the French in 1713); and near by the French republican armies were defeated in 1793 and 1794. See Jost, *Geschichte Kaiserslauterns* (1886).

Kaiserswerth, a Prussian town on the Rhine, 10 miles below Dusseldorf, with 2400 inhabitants, is the seat of the deaconesses' house founded by Pastor Fliedner. See DEACONESSES.

Kaiser Wilhelm's Land. See NEW GUINEA.

Kaithal, an ancient town in the Punjab, India, 93 miles NNW. from Delhi. It is connected traditionally with the monkey-god Hanuman, and is called in Sanskrit *Kapisthala*, the 'abode of monkeys.' It has salt-petre-refineries, and manufactures lac ornaments and toys. It became British in 1813. Pop. 14,754.

Kakapo, or OWL PARROT (*Strigops habroptilus*), a remarkable bird, a native of New Zealand,

belonging to the Parrot family (Psittacidae), but of very owl-like appearance, and, like the owls, nocturnal, or nearly so, concealing itself in holes during the day, except in very gloomy weather. The kakapo takes possession of a hole, where one exists, among stones or the roots of trees, but seems also to have the power of making a burrow for itself. It lives gregariously. The flesh of the kakapo is more pleasant and delicate than that of any other parrot.

It has disappeared from the northern island of New Zealand, and it will probably soon be extinct, unless means are adopted for its protection. It is the only known bird having large wings which does not use them for flight.

Kakodyle. See CACODYLE.

Kalahari Desert. a vast tract of country lying between Great Namaqualand and Bechuanaland, in South Africa, extending from the Gariep or Orange River northwards to 21° S. lat., or the verge of the Ngami region, a distance of nearly 600 miles, with an average breadth of about 350 miles. Although called a desert, it is not entirely such as that name implies. The region is an elevated basin, 3000 to 4000 feet high, with numerous depressions, and bordered in most parts by a wide belt of sandy waterless country. But the rainfall in the interior is sufficient to nourish a fair amount of vegetation. Many parts are thickly covered with high, thorny bushes, which harbour large quantities of game. The inhabitants, called Bakkalahari, keep cattle and grow corn, and live by these and by the chase. Wandering Bushmen are also found in the 'desert.' See Farini, *Across the Kalahari Desert* (1886).

Kalamata, or KALAME, a seaport in the Peloponnese of Greece, on the Gulf of Koron, is the seat of an archbishop. Its exports (currants, figs, olive-oil, and soap) have an annual value of some £300,000; its imports, of £500,000. Pop. 7609.

Kalamazoo, capital of Kalamazoo county, Michigan, is finely situated on the river of the same name, 144 miles by rail ENE. of Chicago. It is the seat of the state insane asylum and of Kalamazoo College (Baptist). The city is the meeting-place of three important railways, and has some fifty busy manufactories of machinery, paper, flour, carriages, windmills, agricultural tools, furniture, &c. Celery is grown in large quantities near the town. Pop. (1890) 17,853.

Kalbe, a town of Prussian Saxony, on the Saale, 17 miles S. of Magdeburg. It has manufactures of textiles, paper, and sugar. Pop. 8850.

Kale, or BORECOLE. See GREENS, SEA KALE.

Kaleidoscope (from Gr. *kalos*, 'beautiful,' *eidos*, 'image,' and *skopos*, 'I see'), an optical instrument invented by Sir David Brewster in 1817. It consists, in its simplest form, of a tube, through whose whole length pass two mirrors or reflecting planes, which are hinged together along one edge, and make with each other an angle

which is an aliquot part of 180, whilst the one end is fitted up with an eyeglass, and the other is closed by two glasses, at a small distance from each other, between which are placed little fragments of glass or other variously-coloured objects. The eye looking into the tube now perceives these objects multiplied as many times as the angle which the reflecting planes make with each other is contained in the whole circumference of a circle, and always symmetrically disposed; and the slightest shaking of the instrument produces new figures. There are various modifications of the kaleidoscope, by some of which its power is much increased; for example the mirrors may be adjustable at various angles measured with respect to a variably distant centre, so that arched patterns may be obtained; and it is not only a pleasing toy, but is sometimes used by pattern-drawers and others, to whom it supplies endless varieties of figures.

Kalends. See CALEND.

Kalevala. See FINLAND.

Kalgan, a Chinese town, 110 miles NW. of Peking, built opposite the passage through the Great Wall, is one of the chief emporiums of the Chinese tea trade with Mongolia and Siberia, some 21,500,000 lb. being exported from here annually. Textiles and smoked provisions are imported from Siberia and Russia. Pop. 70,000.

Kali. See ALKALI.

Kali, an Indian goddess, the wife of Siva (q.v.).

Kalidasa, the greatest dramatist, and one of the most celebrated poets of India. He is known especially through his drama *Sakuntala* ('The Lost Ring'), which, first introduced to the notice of the western world by Sir William Jones (1789), created so great a sensation throughout Europe. A recent translation is Sir M. Williams' (5th ed. 1887). Another drama of the same poet, and next in renown to *Sakuntala*, is the *Vikramocasi* ('The Hero and the Nymph'). Besides these works, Hindu tradition ascribes to his authorship a third drama, *Maharajagunitra*; two epics, the *Raghu-cansa* and the *Kumara-sambhava*; the *Meghaduta* and other poems. But it seems incredible that these are all by one author, differing as they do in style; and it has been assumed that there were at least three Kalidasas. The date of the author of *Sakuntala* is also extremely debatable; it was in the reign of Vikramaditya of Ujjain. But there have been several sovereigns of Ujjain bearing the name from 57 B.C. to 1050 A.D. Most likely the Vikramaditya in question reigned 500-550 A.D.

Kalif. See CALIF.

Kalilah wa Dinnah. See BIDPAL.

Kalinjar, a hill fortress and hill-shrine in the North-western Provinces of India, stands on an isolated rock (1230 feet high), the termination of a spur of the Vindhya Mountains, overlooking the plains of Bundelkhand. The records of the place go back to a period of great antiquity, the name Kalinjar occurring in the *Mahabharata* as that of a city even at that time famous. The whole rock is thickly studded with ruins of ancient Hindu edifices and other works, including gateways, temples, tanks, caves, statues, inscriptions, &c., the most celebrated of all being the remains of the superb temple of Nil Kantha Mahadeo.

Kalisz, the capital of a government (area, 4390 sq. m.; pop. in 1897, 846,331) of the same name in Russian Poland, lies on the frontier river, the Prozna, 132 miles WSW. of Warsaw, and has manufactures of cloth. The *Kalisia* of Ptolemy, it is one of the oldest towns of Poland; in its vicinity numerous relics of antiquity have been discovered, and many ancient burial-mounds exist.



Kakapo
(*Strigops habroptilus*).

Pop. (1892) 18,804. Two battles have been fought here: on 29th October 1706 King Augustus of Poland routed the Swedes, and on 13th February 1813 the Russians defeated the French and Saxons. Here, too, was signed on 28th February 1813 the treaty of alliance between Prussia and Russia.

Kalmar, a town and seaport of Sweden, capital of a lan or county (area, 4436 sq. m.; pop. 234,275) of the same name, is situated on an island in Kalmar Sound, opposite the island of Öland. The town, which was formerly strongly fortified, though the fortifications are now in great part levelled, has a good harbour, a handsome cathedral, and a fine castle, in which, on 20th July 1397, the 'Union of Kalmar' was signed, which settled the succession to the three northern kingdoms upon Margaret of Denmark and her heirs (see DENMARK). The commerce of the town is considerable, and it has manufactures of matches, chicory, and tobacco, and some shipbuilding. Pop. (1895) 12,030.

Kalmia, a genus of plants of the natural order Ericacæ, consisting of evergreen shrubs, mostly about two or three feet high, natives of North America, with red, pink, or white flowers, generally in corymbs. The flowers are very delicate and beautiful, and the corolla is in the shape of a wide and shallow bell. Some of the species are frequent ornaments of gardens in Britain. They delight in a peat soil. *K. latifolia*, the Mountain Laurel, or Calico Bush, occupies large tracts on the Alleghany Mountains. It grows to the height of ten feet, and the wood is very hard. It is narcotic and dangerous; the leaves are poisonous to many animals, and the honey of the flowers possesses noxious properties. A decoction of the leaves has been used with advantage in cutaneous diseases, but taken internally it is fatal. A decoction of the leaves of *K. angustifolia* is used by the negroes of North Carolina, of which state the plant is a native, as a wash for ulcerations between the toes.

Kalmucks, a Mongolian race of people, scattered throughout central Asia, and extending westwards into southern Russia. The name is not employed by the people themselves, but by the Turkic races of Asia and the Russians to designate the Dorbôn (Dorbend) Ordal or Four Allied tribes of the Zungars, Torgol (Keraits or Eleuths), Khoshod, and Dorbol, who live in Zungaria; around Koko-nor in north-east Tibet; in the district called Ordlus, within the great loop of the Yellow River of China; on the western slopes of the Altai (in Kuldja, &c.); and in the steppes between the Don and the Volga and Caspian. These tribes constitute that great division of the Mongol race known as Western Mongols. They are nomads, possessing large herds of horses, cattle, and sheep. Their physical characteristics are those peculiar to the Mongolian race (see MONGOLS). In religion they are nearly all adherents of Lamaism. Their language differs from true or Eastern Mongolian only in being more phonetic; but they have an alphabet of their own. Their literature consists principally of religious books and folk and fairy tales. In recent centuries the most noteworthy events in their history arose out of the emigration of a large band of the Torgol from Zungaria into Russia in 1659. This band was followed by others composed of Dorbol in 1673 and of Khoshod in 1675. Under Ayuka Khan (1670-1724) the Kalmucks figured as an important factor in Russian politics, sometimes as enemies, sometimes as allies. But in 1774 a large body of them, chiefly Torgol and Khoshod, being dissatisfied with the treatment they received at the hands of Russia, returned to the empire of China; after a march in which they endured terrible sufferings, they settled at Hli among the Altai Mountains. See the

brilliant account of the miseries of this march by De Quincey (vol. vii. of *Collected Works*). But there still remain some 110,000 Kalmucks in European Russia; in Asiatic Russia there are probably 55,000 more. The number within the Chinese empire is not known.

Specimens of Kalmuck fairy tales can be read in Julg's edition of the *Siddhi-Kor* (1866) and in vol. i. of Bergmann's *Nomadische Streifereien unter den Kalmuken* (1804).

Kalna, or CULNA, a town of Bengal, 47 miles N. of Calcutta and 28 E. of Bardwan, on the Bhagirathi (Hooghly). The town contains numerous temples, and is a station of the Free Church (Scotland) Mission. It does a large amount of trade by river, chiefly in rice and other natural products. The population has decreased from 27,336 in 1871 to about 11,000.

Kalocsa, a town of Hungary, near the left bank of the Danube, 86 miles S. from Budapest by rail. It is the seat of an archbishop (bishop's see from 1000 to 1135), and has a cathedral, an archbishop's palace (with a library), some monasteries, and an observatory. The inhabitants grow flax, wine, &c. Pop. (1881) 15,789; (1891) 18,167.

Kalong. See BAT.

Kalpi, a town in the North-western Provinces of India, stands among rugged ravines near the bank of the Jumna, 50 miles SW. of Cawnpore. It figured prominently in the wars waged against the Mogul empire, came definitively into British hands in 1806, and was one of the principal agencies of the East India Company. Here on 23d May 1858 Sir Hugh Rose defeated 12,000 of the rebels. The town is mean in appearance, the houses being chiefly mud huts. The population is decreasing—18,514 in 1865; 12,713 in 1891. They manufacture sugar-candy and paper, and export grain, cotton, &c. to Cawnpore and to Calcutta.

Kaluga, chief town of the Russian government of Kaluga, 76 miles by rail NW. of Tula and 188 SSW. from Moscow. Situated in the centre of the empire and on the navigable river Oka, it carries on an extensive trade, especially in corn. It manufactures leather, oil, bast mats, tallow, candles, &c.; but its speciality is 'Kaluga cakes,' sold throughout Russia to the extent of more than £100,000 annually. Pop. (1896) 40,252. Kaluga has often been a place of banishment for political offenders, among others of Shamyg, the Circassian chief. Area of government, 11,942 sq. m.; pop. (1897) 1,178,835. The surface is flat; the soil sandy, clayey, and only moderately fertile; iron ore is worked.

Kama, the principal affluent of the Volga, rises in the Russian government of Vyatka, and after an almost circular course (north-west by east and south-east to south-west) of 1050 miles joins the Volga from the left 43 miles below the town of Kazan. Its chief tributaries are the Vyatka, the Telussovaya, and the Bielaya, all navigable. The Kama is navigable from Perm, a distance of 930 miles. Area of drainage basin, 177,560 sq. m. The river is free of ice about 200 days in the year, and constitutes one of the most important highways of communication between Siberia and Nijni Novgorod and St Petersburg.

Kāma, or KĀMADEVA, the Hindu god of Love. In later Sanskrit poetry, he is the favourite theme of descriptions and allusions; and mythology exalts his power so much that it allows even the god Brahmā to succumb to it. According to some Purānas, he was originally a son of Brahmā.

Kamāran, a little island in the Red Sea, on the Arabian side, nearly opposite Masowah, with an area of 102 sq. m., and inhabited by a few fisher-

men. The island was annexed by Britain in 1858, while the telegraph cable was being laid to Bombay.

Kamchatka (Ger. *Kamtschatka*), a peninsula of eastern Siberia, stretches south into the Pacific between Behring Sea on the east and the Sea of Okhotsk on the west. Area, 465,590 sq. m. The peninsula is long and narrow, swelling out towards the middle, and terminating in a point only 7 miles distant from the northernmost of the Kurile Islands. A chain of volcanic mountains runs down the centre, and reaches 15,408 feet in Kojerevska and 16,988 in Kluchefskaya. The latter was in active eruption at least twice in the 19th century (1854 and 1885). Hot springs abound. The coast on the south-east is formed of rugged, precipitous cliffs. The principal river is the Kamchatka, which flows into the Pacific. The climate is colder than in corresponding latitudes in Europe, and very humid; grass and tree vegetation are consequently luxuriant. The principal occupations of the inhabitants are fishing and hunting. Furs are the most valuable production of the peninsula. The most useful domestic animal is a peculiar kind of dog, which is employed in hunting and sledging. Kamchatka was annexed to Russia at the end of the 17th century, after the expedition of the Cossack chief Atlasof. Pop. 6500, made up of Kamchadales, Koryaks, Lamuts, and a few Russians. The Kamchadales—the preponderating race (2000 in number)—live mostly in the south. They are a hardy people, who dwell in winter in earth pits and in summer in light huts. Their language has no known cognates; but they are now almost completely Russianised. The fort of Petropavlovsk (pop. 350), with a magnificent harbour that is covered with ice only during a brief period of the year, is picturesquely situated on the east coast. A British and French fleet made an unsuccessful attack upon the place in 1854; since then it has not been fortified. See Kennan, *Trav. Life in Siberia* (5th ed. New York, 1879); and Guillemand, *Cruise of the Marchesa* (2 vols. Lond. 1887).

Kamenetz-Podolsk (Polish *Kamieniec*), capital of the Russian government of Podolia, is picturesquely situated near the frontier of Austrian Galicia, on a steep rock above the river Smotritza, an affluent of the Dniester, 243 miles NW. of Odessa and 40 NE. of Czernowitz. There are a Roman Catholic cathedral (1361), a Greek cathedral (16th century), and an Armenian and several other churches. The town was destroyed by the Mongol chief Batu in 1240; taken by the Turks in 1672; returned to the Poles in 1699; and annexed by Russia in 1795. Previous to the partition of Poland Kamenetz was one of the strongest bulwarks of that country against the Turks. Pop. (1871) 22,611; (1897) 34,483, one half Jews.

Kamenz, a small manufacturing town of Saxony, 22 miles NE. of Dresden by rail. It was the birthplace of Lessing. Pop. 7211.

Kames, the name given by geologists to banks and ridges of gravel, sand, &c. associated with the glacial deposits of Scotland. See ASAR.

Kames, HENRY HOME, LORD, a Scotch philosopher, was born in Berwickshire in 1696, called to the bar in 1723, and by his merits fought his way upwards to a leading position there, being raised to the bench as Lord Kames in 1752, and made lord of justice in 1763. He divided his energies between law and philosophy, and was no less noted for his amiability, his conversational powers, his public spirit, and his agricultural enterprise at Blair-Drummond in Perthshire. He died at Edinburgh, 27th December 1782. Besides books on Scotch law he published a series of works more ingenious and interesting than well written: *Essays on the Principles of Morality and Natural*

Religion (1751), a defence of the doctrine of innate ideas at the expense of the freedom of the will; *An Introduction to the Art of Thinking* (1761), and *Elements of Criticism* (1762), two works much less satisfactory than ingenious; and *Sketches of the History of Man* (1774), a miscellaneous and curious collection of speculations on all manner of subjects.

Kampen, a town of Holland, situated near the mouth of the Yssel, $5\frac{1}{2}$ miles by rail NW. of Zwolle. It was formerly a Hanse town and had a considerable trade, which gradually left it as the mouth of the Yssel sanded up. But since the middle of the 19th century the river approaches have been improved, and the trade of the town is reviving. The church of St Nicholas is one of the finest mediæval churches in the country. Pop. (1840) 7760; (1876) 16,454; (1889) 18,767, who are engaged in shipbuilding, commerce, fishing, and tobacco manufacture. Kampen is the Gotham of the Dutch.

Kämpfer, ENGELBERT, German traveller, was born at Lengo, in Lippe, on 16th September 1651, studied medicine at Königsberg, and travelled (1683-94) in India, Java, Siam, and Japan, during which time he spent two years (1692-94) in the last-named country. He died on 2d November 1716. He published *Amoenitates Æthiopicæ* (1712), and after his death appeared his *History of Japan and Siam* (Lond. 2 vols. 1727). Most of his writings exist in MS. in the British Museum.

Kamptulicon. See FLOORCLOTH.

Kamtschatka. See KAMCHATKA.

Kamthi, or KAMTHI, a town and cantonment of the Central Provinces, India, lying 9 miles NE. by rail from Nagpur, on the Kamhan River, here crossed by a fine stone bridge, has a trade in grain, timber, cattle, salt, and piece-goods. Pop. (1881) 50,987; (1891) 43,159. The town dates from the establishment of the cantonment in 1821.

Kanagawa. See YOKOHAMA.

Kanakas. See COOLIES.

Kanara, NORTH, a coast district of Bombay, the most southerly in the Konkan (q.v.), lies south-east of Goa, and has an area of 3911 sq. m.; pop. (1891) 446,351, mostly Hindus, speaking Kanarese (see INDIA, p. 103). For the most part it is a wild forest-country. —SOUTH KANARA, immediately south of North Kanara, belongs to Madras. Its area is 3902 sq. m.; pop. (1891) 1,056,051, over four-fifths Hindus. This district also contains a great extent of forest land, and numerous wild animals. The capital is Mangalore. Both North and South Kanara are partly occupied by the Western Ghâts, contain numerous rivers, and have a heavy rainfall. In both, also, malaria is very prevalent, especially during the monsoon.

Kanaris, CONSTANTINE, a hero of the Greek war of independence, was born in the Isle of Ipsara in 1785, and was master of a small merchant-vessel before the commencement of the war. In 1822 he blew up the Turkish admiral's ship in the Strait of Chios, and later in the same year repeated his feat in the harbour of Tenedos. In August 1824 he avenged the ravaging of Ipsara by burning a large Turkish frigate and some transport-ships which were carrying troops to Samos, and next year was only prevented from burning the Egyptian fleet in the harbour of Alexandria by an unfavourable wind springing up. He was appointed to important commands by the Greek president, Capo d'Istrias, was made senator in 1847, and was minister of marine (1854-55). He took part in the revolution of 1862, and held office repeatedly under the new king. He died 15th September 1877.

Kanauj, one of the great legendary centres of Aryan civilisation in India, to which the Hinduism

of Lower Bengal attributes its origin, stood originally on the Ganges, 65 miles NW. of Lucknow. At present the site consists of a vast number of ruins, extending over the area of five villages, about 4 miles from the Ganges; the river having slightly altered its bed. The most remarkable buildings are Mohammedan mausoleums. Its most prosperous era was the 6th century; early in the 11th it fell before the sultans of Ghazni. Among the ruins there is a modern town of some 17,000 inhabitants.

Kanawha. See CHARLESTON, GREAT KANAWHA.

Kanazawa, a town of Japan, on the west coast of the main island, NW. from Tokyo, manufactures porcelain and silk. Pop. (1896) 88,877.

Kanchinjanga. See KINGHINJINGA.

Kandahar, or CANDAHAR, the capital of central or southern Afghanistan, situated about 200 miles to the SW. of Kabul. It stands in 32° 37' N. lat. and 66° 20' E. long., 3484 feet above the level of the sea. It is in the form of an oblong square, while all its streets run straight, and cut one another at right angles. At the point of intersection of the two main streets there is a large dome (*Charsa*), 50 yards in diameter. Pop. variously estimated from 25,000 to 100,000. Kandahar is well watered by two canals drawn from a neighbouring river, which send to almost every street its own adequate supply; and the same means of irrigation have covered the immediate vicinity with gardens and orchards. Kandahar is a place of great commerce, trading with Bombay, Herat, Bokhara, and Samarcand. Among its permanent residents Kandahar has a larger proportion of Afghans, chiefly of the Durani tribe, than any other city of Afghanistan. There are numerous Hindu, Tajik, and Persian merchants. About 2 miles to the northward rises a precipitous rock, crowned by a fortress impregnable to everything but heavy artillery. Here, amid all the disasters of the war in 1839-41, the British maintained their ground under Rawlinson. Kandahar has been a pivot for the history of that part of Asia during more than 2000 years. It is supposed to have been founded by Alexander the Great, although the name is Persian. A comparative blank of upwards of thirteen centuries in the history reaches to the famous Mahmud of Ghazni, who wrested the strong hold from the Afghans. From that epoch down to 1747, when the native rule was permanently established, Kandahar, with brief and precarious intervals of independence, was held by Genghis Khan, Tamerlane, and by various rulers of Tartary, India, and Persia in turn. In the war of 1878-80 the British entered Kandahar unopposed, and they held the city till 1881, some months after they had evacuated the rest of Afghanistan (q. v.). Through its being touched by the Sibi-Pishin Railway (1891) on the south, Kandahar has greatly increased in political as well as in commercial importance.

Kandavu, one of the Fiji Islands (q. v.).

Kandy, an inland town of Ceylon, on a beautiful little lake among the mountains, 74 miles by rail NE. of Colombo. It is 1665 feet above the sea, and has a mean annual temperature of 76° F. Here are ruins of the palace of the former native kings, and a temple in which a reputed tooth of Buddha's is jealously preserved (see CEYLON). Pop. (1881) 22,926; (1891) 29,252.

Kane, ELISHA KENT, an Arctic explorer, was born in Philadelphia, United States, 3d February 1820, graduated in medicine at the university of Pennsylvania in 1842, and entered the navy as a surgeon, in which capacity he visited China, the East Indies, Arabia, Egypt, and western Europe,

subsequently the west coast of Africa and Mexico; in this last country he did duty on the coast survey. In May 1850 he commenced his career of Arctic discovery as surgeon, naturalist, and historian to the first Grinnell expedition. His account of it appeared at New York in 1854, entitled *The United States Grinnell Expedition*. In the spring of 1853 he again set out, this time as commander of an expedition; the results of it are fully detailed in his *Second Grinnell Expedition in Search of Sir John Franklin* (2 vols. Phila. 1856). He died at Havana, where he had gone for his health's sake, on February 16, 1857. See Life by W. Elder (Phila. 1858), and the briefer one by M. Jones (Lond. 1890).

Kane, SIR ROBERT, chemist, was born in Dublin, 24th September 1809. He was educated for the medical profession, in 1832 was received as a member of the Royal Irish Academy, and in the same year projected the *Dublin Journal of Medical Science*, which, at first confined to chemistry and pharmacy, was afterwards extended to include practical medicine. In 1840 he received the gold medal of the Royal Society of London for his researches into the colouring matter of lichens, and in 1847 the Cunningham Gold Medal of the Royal Irish Academy for his discoveries in chemistry. From 1834 till 1847 Kane was professor of Natural Philosophy to the Royal Dublin Society. In 1846 he originated the Museum of Industry in Ireland, was appointed its first director, and the same year received from the Lord-lieutenant the honour of knighthood. He held for a number of years the office of president of the Queen's College, Cork, which he resigned in 1873, together with the directorship of the museum. In 1877 he was elected president of the Royal Irish Academy, and he died 16th February 1890. His chief books are *Elements of Chemistry* (1842) and *Industrial Resources of Ireland* (1844).

Kangaroo (*Macropus*), a genus of marsupial quadrupeds, of which there are many species, almost all Australian, although a few are found in New Guinea and neighbouring islands. The genus, as now restricted, contains, according to the most reliable estimate, twenty-three species. The kangaroos are of different sizes: some of the Wallabies, which

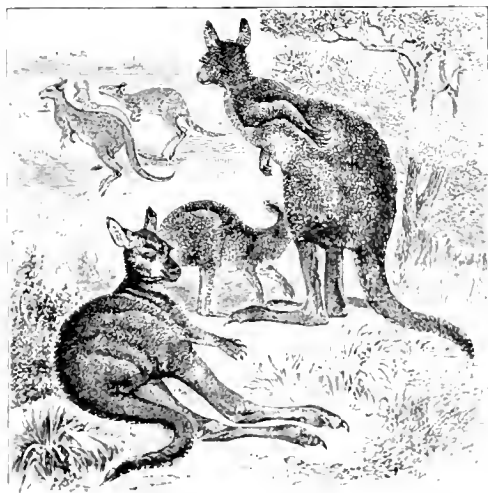

The Great Kangaroo (*Macropus giganteus*).

really belong to the same genus, being comparatively small, while the Great Kangaroo (*M. giganteus*) attains a length of 8 feet, counting the long tail.

They are entirely herbivorous—mainly grass feeders—and the two lower incisors, which are elongated, play upon each other like the blades of scissors and crop the grass. The tail is very thick and strong, and the animal uses it as a third leg when moving slowly. The hind-legs are very strong, while the fore-limbs are short. They are very powerful animals, and the hind-limb forms a very effectual weapon for ripping open the bodies of dogs, with the aid of which they are sometimes hunted. They make enormous bounds, and get over the ground very swiftly and gracefully. Some kangaroos can jump a fence 11 feet high; most can jump one of 9 feet. In the districts where they are still numerous, they are formidable consumers of pasture; two kangaroos eat as much grass as three sheep. They are treated as vermin, being hunted, shot, poisoned, or killed by means of extensive battues—'yarding' or 'driving'—when parties of horsemen chase them into enclosures and kill them there, many hundreds at a time. The skin is valuable for leather, both for shoes and gloves. The flesh is good eating, the tail being a delicacy, and producing excellent soup. The great kangaroo was discovered in 1770 on the coast of New South Wales during Cook's first voyage. One of the most remarkable types of kangaroo is the Tree Kangaroo (*Dendrolagus*), in which the hind-limbs have become proportionately shorter in accordance with its arboreal life. The kangaroos and Wallabies breed freely in the Zoological Gardens at London, and the young, as in all Marsupials (q.v.), are born in a very imperfect condition. They remain within the pouch of the mother, or retreat there in case of danger, long after they have ceased to be nourished by the maternal milk.

Kangaroo Apple, a species of Solanum (q.v.) (*S. laetatum*), with a somewhat shrubby succulent stem, smooth pinnatifid or entire leaves, and lateral racemes of flowers; a native of Fern, New Zealand, Australia, and Tasmania, in which latter countries its fruit is called kangaroo apple, and is used as food. When unripe, it is acrid, and produces a burning sensation in the throat; but when perfectly ripe, it is wholesome.

Kangaroo Grass (*Anthistria australis*), the most esteemed fodder-grass of Australia. It grows to a height much above that of the fodder-grasses of Britain, affords abundant herbage, and is much relished by cattle. The genus is allied to Andropogon, and has clusters of flowers with an involucre. The awns are very long and twisted, both in the kangaroo grass and in a nearly allied species, *A. ciliata*, which is one of the most esteemed fodder-grasses of India.

Kangaroo Island, an island of South Australia, at the mouth of the Gulf of St Vincent (see map at ADELAIDE), is 87 miles by 34 broad, with a fine climate, poor and sandy soil, and 379 inhabitants—all white.

Kanizsa, the name of two towns in Hungary. (1) Nagy (or Great) Kanizsa, 136 miles by rail SW. of Budapest, has an active trade in agricultural products, and manufactures bricks, beer, and spirits. Pop. 18,473.—(2) Old Kanizsa (Kanizsa) stands on the Theiss, 15 miles SSW. of Szegedin. It grows corn and tobacco, and rears cattle and sheep. Pop. 15,069.

Kano, capital of a province of the same name, in the Negro state of Sokoto, Central Africa, stands in the middle of the country, about 250 miles SSE. of the city of Sokoto. The province, estimated to contain 500,000 inhabitants, has from its beauty and wealth been called the 'Garden of Central Africa.' The wall which surrounds the town of Kano is 15 miles in circuit; but the wall embraces, besides houses, gardens and cultivated fields. The

place is the chief town of the Haussa (q.v.) race. Pop. (according to Robinson) in 1896, 100,000.

Kansas, the central state of the American Union, and the eighth in area, is bounded N. by Nebraska, E. by Missouri, S. by Indian Territory, and W. by Colorado. It is about 400 miles from east to west, and 200 from north to south, and contains an area of 82,080 sq. m. The surface is for the most part a rolling prairie, rising in the north-west to between 3000 and 4000 feet. Along the eastern boundary the average elevation is 800 feet, and the rise is so gradual as to be imperceptible; there are no mountains in the state. The bottoms along the larger streams are commonly called valleys, and vary from $\frac{1}{4}$ mile to 5 miles in width; in eastern Kansas they are deeply depressed, and are skirted by bold bluffs rising to 300 feet, but in the west the line between valley and upland can hardly be distinguished. Kansas has no navigable river except the Missouri, which forms a portion of its eastern boundary. The Kansas or Kaw drains nearly half the state, and the Arkansas drains another large portion; the Neosho and Marais des Cygnes furnish the water system of south-eastern Kansas. The larger streams, as the Kansas and Arkansas, are rivers of the plains, with light banks and sandy bottoms; but many of the smaller rivers have rock bottoms, and supply abundant water-power. The timber of the state is found in a narrow belt along the watercourses, principally in the east.

Kansas has a climate subject to extremes of temperature, but neither excessive cold nor heat prevails for long periods. There is a great proportion of bright, clear weather in all seasons of the year. While a record of 106° F. above zero has been observed, cases of fatal sunstroke are unknown, and men pursue their ordinary outdoor avocations with scarcely an interruption throughout the year. The mercury rarely falls below zero, and in many seasons the farmers plough during every month of winter. The mean annual rainfall is 37.10 inches; but in the west the supply is much more scanty, and in the upper Arkansas valley irrigation by means of ditches has been introduced. The average annual temperature is 53° F.

The minerals of Kansas include lead and zinc in abundance in the south-east; coal of excellent quality, the coalfield occupying all the eastern portion of the state; lignite in the west; immense beds of rock-salt; and mineral paint, gypsum, good building-stones, brick clay, and material for hydraulic cement. The output of coal in the year 1890 was 2½ million tons, of lead 5000 tons, and of zinc 20,000 tons.

Kansas is an agricultural and pastoral state. The soil throughout is uniformly fertile, but there is a considerable difference in actual productiveness owing to the difference in the rainfall. The area under wheat, maize, and oats is over 10,000,000 acres (1895). The annual produce of wheat may be set down as upwards of 70,000,000 bushels, of maize nearly 150,000 bushels, of oats 45,000,000 bushels, besides rye, barley, buckwheat, flax, potatoes, beans, peas, sorghum (for sugar), and tobacco. Great quantities of prairie hay are cut on the still uncultivated prairie lands. The state is especially suitable for cattle raising, large stocks of cattle and swine (as well as horses, sheep, &c.) are kept, and meat packing is a great industry in Kansas City. Creameries are numerous, and more and more attention is given to the raising of blooded stock. Forestry also has engaged the attention of the farmers, and thousands of acres of planted timber now break the surface of the prairie.

The manufacturing industries are chiefly those

connected with agriculture and stock-raising. Of these the most important is beef and pork packing, the principal establishments being at Kansas City. The flouring-mills are next in importance, and then the foundries, and the manufacture of stoves and agricultural implements. The building of railways began in Kansas in 1860; in 1890 every county in the state save five had one or more lines, their total length exceeding 8800 miles.

Kansas is divided into 106 counties, and sends two senators and seven representatives to congress. State officers and members of the legislature are elected every two years. The marked features of the constitution are the liberal Homestead (q.v.) exemption; the privileges of married women, who may carry on business and hold property as if single; the suffrage provisions, which allow women to vote at school and municipal elections; and the prohibitory statute which forbids the manufacture or sale in Kansas of intoxicating liquors for other than medicinal or mechanical purposes. There are insane asylums at Topeka and Osawatomie, a boys' reformatory at Topeka, an asylum for the blind at Kansas City, a Soldiers' Orphans' Home at Atchison, an institution for the education of the deaf and dumb at Olathe, and an asylum for idiotic and imbecile youths at Winfield; and the state in 1889 adopted also the industrial school for girls at Beloit. In each township two sections (1250 acres) have been given to the common schools, and the sale of these lands forms the basis of the permanent school fund, which amounts to about \$5,000,000. The annual expenditure is also about \$5,000,000. In 1890 there were 12,152 teachers, instructing 389,570 children in the elementary schools, besides 218 teachers in 16 secondary schools, with 3950 pupils. The state also maintains a university at Lawrence, which had 542 students in 1890; an agricultural college at Manhattan (514 students); and a normal school at Emporia (1120 students). There are also a number of denominational and other colleges in the state. Co-education prevails, with hardly an exception.

History.—Kansas when first known to white explorers was occupied by several tribes of Indians, from one of which, the Kaw or Kansas Indians, the river and the state derive their names. The state, save a small fraction, was acquired in the Louisiana purchase, and was organised as a territory by the passage of the Kansas-Nebraska Act in 1854. The act provided that the question of the existence of slavery as a permanent institution in the territory should be decided by its people. Kansas at once became the battle-ground between the partisans of slavery and freedom. Large parties from the bordering slave-state of Missouri repeatedly invaded the territory; and armed colonists from South Carolina and other southern states came to take possession. These were met by immigrants from the northern states. Both parties started towns and settlements. Elections were attempted, but resulted in the seizure of the polls by the pro-slavery party and the refusal of the Free State party to abide by the declared results. Collisions became numerous, and robberies and murders were committed. The Federal administration sided with the pro-slavery party, and used the government of the territory and the United States troops against the Free State party. John Brown (q.v.) took part in the civil war which prevailed, and many fights that were almost battles took place. The Free State party was steadily reinforced from the north, and by the year 1857 seemed everywhere in the ascendant; but as late as May 1858 occurred what is known in Kansas history as the 'Marais des Cygnes massacre,' in which six Free State settlers were killed and four badly wounded by a

party from Missouri. After several futile endeavours to organise, however, the Wyandotte constitution was finally adopted in 1859, and on the 29th of January 1861 Kansas was admitted as a state of the Union. The civil war immediately followed. Out of a population of 100,000 Kansas sent 20,000 soldiers to the field. Kansas suffered greatly throughout the war, but the building of railroads, begun during its continuance, was pushed with energy at its close; immigration poured in on a scale before unknown in America, and the career of the state has since been one of almost uninterrupted prosperity. The population of Kansas in 1860 was 107,206; in 1890 it was 1,427,096. The population of the principal cities in 1890 was: Kansas City, 38,316; Topeka, the capital, 31,007; Wichita, 23,853 (as compared with 4911 in 1880); with Leavenworth, Atchison, and Fort Scott below 20,000 and above 10,000.

Kansas City, the second city of Missouri, and one of the great towns of the west, is situated on the south bank of the Missouri (here crossed by a fine railway bridge), where the river makes a sharp bend to the east, 283 miles by rail W. by N. of St Louis. The notable part of the city is built upon a series of steep hills, but the site has been greatly improved by grading. Large sums have been spent in laying sewers and water and gas pipes; and cable-tramways extend in all directions, the lines having a total length of at least 35 miles. The state frontier-line bounds the city on the west, and consequently a large suburb on this side, also called Kansas City, is in the adjoining state of Kansas. This suburb, connected with Kansas City by a remarkable elevated railway, has a population of some 40,000, and contains great stock-yards and pork-packing establishments. The larger Missouri town possesses numerous fine streets, and handsome residences on the hills. Its public buildings include many well-designed churches, a fine United States court-house, the imposing building of the Board of Trade, and several hospitals; there are two medical colleges here, and about thirty public schools. The city is the terminus of a number of important railways, and is a principal distributing centre for the rich agricultural region to the south and west. The sales of farming implements alone in 1887 reached \$15,000,000. There are great grain-elevators and stock-yards, and pork-packing is a principal industry; while the manufactories, mostly in the lower section of the city, turn out railroad iron and car-wheels, shot, flour, beer, butterine, soap, furniture, &c. Pop. (1860) 4418; (1870) 32,260; (1880) 55,785; (1890) 132,618. The assessed valuation in this last year was \$53,017,290. See a paper by Charles Dudley Warner in *Harper* for October 1888.

Kansas River is formed by the junction of the Smoky Hill Fork and the Solomon River, in Kansas, at about 97° 25' W. long., and flows generally eastward to the Missouri, which it enters just above Kansas City. Length, nearly 300 miles, or including its forks, 900 miles. Its chief tributary, the Republican River, has a length estimated at 550 miles. The importance of the Kansas River for navigation is, however, not great.

Kan-su', the most north-western province of China (q.v.).

Kant, IMMANUEL, probably reputed at present the greatest of all modern philosophers, was born April 22, 1724, at Königsberg, in East Prussia, where, February 12, 1804, in the eightieth year of his age, as professor of Philosophy in the university, he died. His life, as that only of a student and a teacher, offers few vicissitudes. His parents were of humble life, but pious,

respectable, good people—his father a saddler, or, more properly, a strap-maker. The tradition is that the family was of Scottish descent, and that the name was originally spelt Cant. The tradition is probably perfectly correct as regards the descent; but even Kant's grandfather is found to have had his name already spelt Kand or Kant. So far as school and college are concerned Kant may be considered as thoroughly educated; but during the whole course of these, up to his twenty-third year, he must, as regards comfort, have had but a poor and straggling time of it. For the following nine years Kant supported himself as a family tutor, the usual resource of the ordinary German student, or indeed of the poor ambitious student anywhere. Becoming doctor of philosophy in 1755, he qualified himself in the same year as a *privatim docens*, and, as such, he remained for fifteen years what we would call a private lecturer, though in connection with the university. Not till 1770, when he was forty-six years of age, did Kant become an ordinary professor there (about four years before that he had been promoted to a sub-librarianship, with an annual dole of some eleven pounds sterling). For nearly fifty years, then, we may say that Kant was a teacher of philosophy at Königsberg—a very general one, for he had to embrace in his lectures mathematics, physics, logic, metaphysics, natural theology, anthropology, physical geography, and, more still, *Philosophical Encyclopædia*, to say nothing of pyrotechnics and the art of fortification! There can be no doubt that Kant was acceptable as a teacher, and that his lectures were well attended. We have an interesting testimony from Herder to that effect. His most popular course, however, was, probably, his shallowest—that, namely, on physical geography—though not without features, as well curious in Kant's regard, as, in themselves, interesting and instructive. Only during the last twenty years of his life can it be said that Kant was famous. Before that, even the correspondence with Lambert and Mendelssohn is insufficient to show that his excellent reputation locally had ever been sensibly more general. With or without name, he was the author of a separate work or two that had made no mark; and he had occasionally written creditable papers in the public journals, principally of his own neighbourhood. He was a small, thin, somewhat rickety, bundle of bones; scarcely 5 feet high; as the Scotch say, an *unb-firmit* little body; honest, truth-speaking, perfectly well conducted, though not remarkable for his attendance in church; kindly and gracious, and, in his own slender, pedantic-easy way, sufficiently hospitable; but, as evinced by the modest request he refused to the sorely-straitened Fichte, with a tight enough grip on his own little sayings.

The writings of Kant can be respectively assigned to three periods, according as they precede, follow, or belong to the dates of his three great *Kritiken* (Critiques). Of these the first is the critical date, 1781; and of the whole period that precedes it the writings are, letters included, some thirty in number. Now, let them be as they may, it is not perhaps improbable that, had Kant died the author of these writings only, both he and they would have been long ago forgotten. Neither his *Thoughts on the True Estimate of Living Forces*, nor his *General Natural History and Theory of the Heavens*, nor his *Dreams of a Visionary illustrated by Dreams of Metaphysics*, nor even his Latin dissertation *De Mundi Sensibilis atque Intelligibilis Formæ et Principiis*, would have availed, it may be, to operate a diversion whether for works or workman. There is, of course, in one of the smaller papers, the hint on Kant's part that the

opposing course of the tides is possibly acting in retardation of the rotatory motion of the earth; but, otherwise, the four essays named form all that is of any veritable importance in the first literary period of Kant. Not but that, generally, all through this period, there is evidence of much information and much intelligent curiosity on the part of an earnestly-thinking nature that has already attained to a certain largeness and freedom of scope. The *Thoughts on the True Estimate of Living Forces* was Kant's first publication, and is sufficiently creditable to a young man of twenty-three, though on a question that at that moment had been for some time already authoritatively settled. It is, however, difficult to find in it either the comprehensive inaugural programme of his idolaters, or even the prophetic excellences of his more moderate admirers. The *Theory of the Heavens* was published in 1755; and as regards the suggestion of a nebular hypothesis in that reference Kant deservedly claimed for himself the priority whether we look to Herschel or Laplace. Here, too, nevertheless, Kant only met with his usual bad luck for long. The little anonymous booklet of two hundred pages attracted no attention, not even that of the king, to whom it was dedicated. It may be attributed to Kant as a merit that, at this early date, he speaks of the possibility of there being planets in existence beyond Saturn, as there is to be found in the *Physical Geography* a similar conjecture as regards the existence of what are now called the asteroids. But in the latter reference Kant was not the first; while his suggestion in the former was an inspiration from an idea of his own in regard to comets. What, he asked himself, if, out and beyond Saturn, there were planets in paths increasingly eccentric which, as it were, would tend on the whole to make comets of planets! It is but just to note that, a year before its publication, the *Theory of the Heavens* had been already announced in the essay that concerns the earth's rotation. When one thinks of what speculations must have occupied at this time the mind of Kant, one must acknowledge that all this speaks volumes for the industrious inquiries and the ardent and original reflections of this young man of thirty.

Published in 1766, Kant's *Dreams of a Visionary* is a rather remarkable paper. Kant, all his life, at least longed to believe in the immortality of the soul and the actuality in existence of a world of spirits. He was very much impressed, accordingly, by all those stories in regard to the supernatural intuitions of Swedenborg, so much so, indeed, that he had actually bought, at the enormous expense of seven pounds sterling, the eight quarto volumes of the *Arcana Cælestia*. And it is in consequence of his reading in these volumes that he is led to write, half-seriously and half-ashamed, this little, for him exceptional, paper, that is, however, only in the air. Not but that there are, in all probability, signs to be detected in it of that study of Hume at last that led in the end to what has determined itself as his proper work and as his proper worth. These, however, are but obscure and semi-articulate hints, and can hardly be regarded as sufficient to justify the editors of Kant in characterising this writing as 'announcement of his greater enterprises.' The *Dissertatio de Mundi Sensibilis atque Intelligibilis Formæ et Principiis*, published in 1770, is really the first of these, his critical endeavours. It professes to speak of the form and principles of both of the worlds to which we may be said to belong; and it certainly succeeds to its own wish in regard to one of them. For the world of the senses, namely, it does find, before experience, and in anticipation of experience, actual elements of experience that are not due to experience at

all, perceptions of things that are not due to the perception of things, but only to the mind itself, only, as it were, to projections from within that throw themselves without, and stand around without. These are Time and Space, which, original or native to the faculty itself, are the *a priori* forms of perceptive sense. That, at least, is the conclusion of Kant; and, in that regard, he is now about as complete in the *Dissertation* as he was eleven years afterwards in the *Critique*. A similar completeness does not follow him at present, however, in respect to the other or *intelligible* world, the world of ideas, of the intellect, the name of which also runs in the title. Probably no one reads this Latin work in these days; but if any one attempts it, most assuredly he will find himself, in regard to what of the *intelligible* world he is to understand he has learned from it, only exasperated. It is only possible to suppose of Kant here, that, having succeeded to his mind in the discovery of *a priori* forms of sense, he can as yet only search and search, and find himself vaguely and variously *hugged*, in a similar attempt with reference to the *a priori* principles of the understanding, the intellect. For success in that respect he had still to wait for the coming into his mind of the idea of school-logic and the forms of the syllogism.

That was the triumph of the great work of 1781, the *Critique of Pure Reason*. We know that what led to the whole work of Kant was the endeavour on his part to find in the proposition of causality that apodictic necessity, and that rationale of it, which Hume, as against his own solution of custom, habit, challenged from philosophy and the world at large. *Every change must have a cause*. Yes, said Hume, but such an affair as change can only be known by experience; without experience it would be unknown. Consequently, then, it is but a fact of experience, and, like every other such fact, we know that it *is*, but not that it *must* be. The necessity we attribute to its appearance is only a necessity of custom. On the contrary, says Kant, we really do attribute to any appearance of change a perfect certainty of necessity, a necessity absolute, a necessity, not a dot or a jot, not one iota less apodictic than we attribute to any proposition, to any axiom of the mathematics. That the shortest line is the straight line—our conviction in that respect is not more fixed, assured, immovable, than our conviction that every effect, every change, *must* have a cause. And so far, no doubt, Kant was right. But what, then, further, of the reason of this necessity, the rationale of it, the explanation of it? Seeing that the proposition of causality is really an inferential proposition—a proposition with a conclusion, as it were, from premises—one would have thought it natural on the part of Kant to turn, in the first place, to the consideration of reason and reasoning rather than to the consideration of actual perception and sense. But, probably, as has just been named, it was the suggestion of mathematics that led to this. To explain the necessity of mathematics might be to explain also the necessity of causality. We can leave Kant's consequent proceedings to be pictured here; it is not difficult to realise how he came to his conclusion and to his belief in it. A mathematical truth depended just on the fact of perception; but, inasmuch, again, as a mathematical truth was an apodictic truth, the perception on which it depended could not be a perception of experience. Such perception could not be a *posteriori*; it must be a perception absolutely independent of experience; a perception, consequently, then, special, proper, and peculiar; a perception *sui generis*—a perception *a priori*! But how could that be? Why, only by space, which was the source and

the seat, and, so to speak, the blackboard and tablet of mathematics, being itself *a priori*. But if space were *a priori*, so would time be. As we have seen from the *Dissertation*, this of a *proxi* perception, was probably Kant's first acquisition and conquest—towards the rationale he sought. Evidently, however, it was still inadequate to the want. Time and space might be *a priori*, but change, a mere experience of special sense, could not lie there. Could we not add from the intellect an inferential *a priori* form, which, availing itself of the *a priori* perceptive form, might, in combination with it, give birth to an *a priori schema* in supply of the entire virtue of necessity to every actual instance of causality that could possibly emerge? It was here now that the suggestion of logic gave to Kant his whole tree of *Categoris* as *synthesis* in correspondence with the *analysis* of the functions of Judgment. Judgments, propositions, were universal, particular, singular; affirmative, negative, infinite; categorical, hypothetical, disjunctive; problematic, assertoric, apodictic. So far, what was concerned was in its nature analytic; but if we supposed an equal number of synthetic functions, then under the same four general rubrics of Quantity, Quality, Relation, and Modality, we should have the twelve correspondent categories of unity, multitude, allness; reality, negation, limitation; substance, causality, reciprocity; possibility, actuality, necessity. It is impossible to follow Kant here in the working-out of all that; but it is really enough to understand as much.

These categories now were *constitutive*; they actually entered into the composition and constitution of things as these presented themselves for the perception of sense. That is, as acting on the *a priori* perceptive matter, or manifold of space and time, they (the categories) gave rise to a pure or *a priori* perceptive-intellectual *schemata* that, combining with the sensations of sense as these came into consciousness (from whence they might), produced, in projection around us, this ruled and regulated, orderly, intelligible universe, in which the necessity due to the categories was the very source of law. To these constitutive materials there were added, *regulatively*, the three *Ideas*. Determined by the Category of Relation in the three forms which are found under it, there are, generically, three forms also of the logical syllogism, applicable respectively to the unconditioned of the *categorical* synthesis in a subject, of the *hypothetical* synthesis of the terms of a series, and of the *disjunctive* synthesis of parts in a system. And these results, otherwise named, are the objects of psychology, cosmology, and theology, or the soul, the world, and God. These, however, are but ideas—only centres, as it were, for further simplification and regulation among the categories themselves. It is for the *Critique of Practical Reason* now to come in and extend at least the conviction of existence to these transcendental objects of soul, world, God; and what supplies authority and fulcrum to this critique in this is the *categorical imperative*—the fact of the practical ego possessing a categorical imperative in determination of its own will. Considering that the ego, *theoretically*, was declared to be no more than an idea—no more, so to speak, than a mere logical dot on a mere logical *l*—it is hard to understand how, *practically*, it can rise at once into such throne of an autocrat. But this is certain: it is for his practical critique that Kant deserves all our heartiest praise. So much has Kant what he writes at heart here that all seems to issue at once from within him in a single breath. No purer, no more living morality, has ever been professionally produced by philosopher than glows in the *Ethics* of Kant.

It would appear that when Kant had accomplished as much as this, he turned back to look upon it and reflect. I have found, he seems to have said to himself, my Categories in the *a priori* of the understanding, and my Ideas in the *a priori* of the reason. That is enough for our theoretical and practical interests; but what of our only other generic interest that remains—what of our interest that we call *aesthetic*? That refers to a function on our part that seems intermediate between the other two—the theoretical and practical functions. But these depending respectively on the Understanding and Reason, is there nothing similarly intermediate between these two again? Yes, there is Judgment. And so it was that Kant was led to his third great critique, the subjects of which were generally, to say so, the products of Art—i.e. Beauty, Sublimity, Design. Beauty originated in the harmony of our own two constitutive elements—sense on the one side and intellect on the other. Sublimity was the feeling of the exaltation in mind above every menace and magnitude of sense. Since design, so to speak, meant evident arrangement by another hand as though from without, it was impossible to give it place, on such terms, in our world; which, in the contributions of special sense (mere sensations), in time and space, in the categories, the ideas, and all else, was only a world within—a world, indeed, all but wholly of our own construction within. We could only say of it (design), in such circumstances, that we ourselves were so fashioned that we could only see into our world *as though* it were the product of an understanding.

Among the remaining works of Kant there are some of considerable bulk and some interest, but little value—at least so far as originality is concerned. Such are the *Anthropologie* and the *Logik*. The *Streit der Facultäten*, *Rechtslehre*, *Tugendlehre*, *Religion innerhalb der Grenzen der blossen Vernunft*—all are well worth reading, and will greatly help to a general understanding of their author. In that latter respect the *Prolegomena*, the criticism of Eberhard, and the essay on the Progress of Metaphysics since Leibnitz and Wolff, are specially to be signalised, and may even be named indispensable. The essay in the philosophy of nature, *Metaphysische Anfangsgründe der Naturwissenschaft*, cannot well be neglected, and still less, perhaps, various little essays in natural history. Even the critique of Herder will be found good, and, just on the whole, it may be said that no work on Kant's part, however small, should, if belonging to the middle or concluding period, fail to be read. The little essays that bear on natural history, for example, however unimportant they may appear, contain more than one declaration that is of interest, in so far as Kant, though averse, probably, to the dogma of direct creation, has yet, in his perception of the existence of ideas, and of actual concert on ideas, in nature, never a thought of even the suggestion of a mechanical evolution through chance.

It is impossible to overrate the enormous impulse which Kant has been the means of giving to the study of philosophy, both in Germany and everywhere else (as well in America and the East as in Europe). Quite a host of names, besides those of Jacobi, Fichte, Schelling, Hegel, Herbart, Krause, Schopenhauer, Schleiermacher, might be mentioned in this connection. It is not quite certain, however, that Kant's work will prove to have been more in the end than one principally of suggestion. We know not but that, if all that monstrous gaunt machinery—*aesthetic*, analytic, what not—had been offered precisely as the machinery proper for the production of the necessity in causality we know not but that, if all that

monstrous gaunt machinery (time and space themselves shut up within it) had been seriously offered, for that purpose, from Germany, and in the time of *Hume*—we know not but that it might have been received with something more unequivocal than a smile! But be that as it may, and assuming the constructions of Kant to prove in themselves neither a solution for the problem of the universe, nor yet for the problem of causality, we have still to bear in mind what *suggestion* in his regard means. Apart all consideration of his followers, the truth is that it is to Kant we owe—with discount only of all necessary historical addition—our entire metaphysical material at present. Really, whatever metal of speculation is anywhere turned now, the ore of it was Kant's. The *Critique of Pure Reason*, if not precisely to be named a liberal education, very certainly is, has been, and will remain, an education in philosophy.

BIBLIOGRAPHY.—A complete bibliography of Kant would cover pages, and is beyond the proportions of this publication. We name only what will probably be found most useful. Of the whole works four editions may be mentioned, those of Rosenkranz and Schmbert (Leip. 1838 42); of Hartenstein (Leip. 1838-39); again of Hartenstein (Leip. 1867 69); of V. Kirchmann (Leip. 1868, and further). Benno Erdmann (Leip. 1880) edits a notable edition of the *Critique of Pure Reason*, and Reclam, of Leipzig, publishes a very useful small edition of the same work, edited by Kehrbach. Of translations of the *Critique of Pure Reason* into English there are those of Meiklejohn and Max Müller, and the text-book to Kant of Stirling. Abbott and Bax also translate into English important works of Kant, the one the *Ethics* and the other the *Prolegomena*.

Of writers generally in regard to the philosophy of Kant the following may be mentioned—German: Hegel, Michelet, Erdmann, Ueberweg, Schwegler, Kuno Fischer, L. H. Fichte, Chalybaeus, Urici, Biedermann, Weigel, Portlage, Ritter, Kirchner, Drechsler, Liebmann, Haym, Oeschinger, Schaarschmidt, Zeller, Drobisch, Steffen, Wundelband, V. Hartmann, Krause, Volkelt, Hölder, Vaibinger, Staudinger, Lasswitz, Spieker, Paulsen, Thiele, Cohen, Riehl, Stadler, Thilo, Pöhring, Sigwart, Falckenberg. French: Ott, Willin, Wocquier, Foncher de Careil, Barchou de Penhoen, Saintes, Maurial, Saisset, Villers, Vacherot, Cousin. Italian: Galuppi, Testa, Spaventa, Lilla, Cesa. English: Nitsch, Wilhelm, Hodgson, Laurie, Montgomery, Bolton, Ingleby, Adamson, Seth, Hastie, Bowen, Morris, Porter, Caird, Watson, Mahaffy, Maguire, Monck, Green, Wallace, Mansel, Lewes, Nakashima, A. J. Balfour.

Kaolin, or CHINA CLAY, is fine white clay used in making porcelain. Like less pure clays, it is essentially a hydrous silicate of alumina, but it is a comparatively rare substance. The clays found in most localities contain iron in sufficient quantity to colour them red or buff when burned in a kiln, but China clay is of a pure, or nearly pure white both before and after it is fired. This, together with its refractory nature, makes it of great value in the manufacture of porcelain, of which it forms the chief ingredient. It is also used to a considerable extent by paper-makers, and in less quantity in the making of some chemical products. Kaolin is a product of the decomposition of the felspar of a granitic rock. The name Kaolin is derived from the Chinese *Kao-ling*, 'high ridge,' the name of hills near King-tih-chin in Chiang-hsi, a chief seat of the porcelain manufacture in China. Clay from this district was sent to Europe early in the 18th century by Jesuit missionaries; similar clay was discovered in Saxony; and about 1755 it was discovered in Cornwall, whence the chief English supplies are obtained, some being also obtained in Devonshire in all, about 30,000 tons a year. Kaolin is found in France, and in Nebraska and other states of the American Union; in the United States the annual consumption is some 18,000 tons. See CORNWALL, FELSPAR, POTTERY.

Kapellmeister (German), the director of an orchestra or choir, more especially the band of a ruling prince in Germany.

Kapila, the founder of the Sankhya philosophy, one of the philosophical systems of the Hindus. He is usually reputed to have been a son of Brahma; but he is otherwise described as an incarnation of Vishnu.

Kappel. See CAPPEL.

Kara, the name of a gold-mining district, in a dreary valley in eastern Siberia, about 300 miles from Chita and nearly 5000 from St Petersburg. The mines are the private property of the czar, and are worked by convicts, of whom there are generally about 2000 stationed here. The annual yield is 6400 oz. of gold. Since 1879 Russian political prisoners have been regularly sent to this remote region. See Kennan's interesting papers in the *Century Magazine*, June-August 1889.

Karachi. See KURRACHEE.

Kara-George. See CZERNY.

Kara-hissar. See AFIUM-KARA-HISSAR.

Karaites. See JEWS (*Religion*).

Kara-köl. See BOKHARA.

Karakorum. (1) a name given, but according to the best geographers erroneously, to the Muztagh range, in the western Himalayas; sometimes also it is given, again erroneously, to the Kuen-Lun range on the north of Tibet. The Muztagh or Muztagh range is that part of the Himalayas which lies to the west of the Indus and extends as far as the head of the Gilgit Valley. It embraces some of the loftiest peaks of the Himalayan system.—(2) The name is properly appropriate to a pass (18,550 feet), the culminating point of the route between India and East Turkestan, in 35° 33' N. lat. and north from Leh.—(3) Karakorum is also used to indicate the old Mongolian capital, to the north of the desert of Gobi, on the Orkhon, a tributary of the Selenga River. The ruins remain. For the mountains, see HIMALAYA; ASIA, p. 485; and Conway, *Climbing in the Karakorum Mountains* (1894).

Kara-kum. See KIZIL-KUM.

Karaman. See CARAMANIA.

Karamnasa, a river of India, divides Bengal from the NW. Provinces, and, after a course of 146 miles, enters the Ganges from the right. The Hindus hold it in the greatest abhorrence, and will neither drink nor touch its waters, although they are of crystal clearness and abound in fish.

Karamsin. NICHOLAS MICHALOVITCH, the greatest of Russian historians, was born on 12th December 1765, at Mikhailovka in Orenburg. His father, an officer of Tartar descent, placed him in the army, but he soon left it to devote himself to literary pursuits, and, after a tour in Germany, Switzerland, and France, established the *Moscow Journal*, and published volumes of tales, critical papers, translations, &c. The work which first gained him a high reputation was his *Letters of a Russian Traveller* (6 vols. 1797-1801). In 1803 he was appointed imperial historiographer, and from this time laboured uninterruptedly at his *History of Russia* (11 vols. 1816-29); but he only brought it down to 1613, dying on 3d June 1826 in the midst of his labours. In this great work, the first really critical history of Russia, Karamsin manifests so much enthusiastic admiration for men like Ivan the Terrible that it has been called the 'Epic of Despotism.'

Kara Sea is the portion of the Arctic Ocean lying between Nova Zembla and the Yabmal Peninsula, off the Siberian coast. The rivers Obi and Yenisei discharge their waters into its north-

eastern corner. Since Nordenskjöld's famous voyage in the *Vega* (1875) the English navigator, Captain Wiggins (who first demonstrated the navigability of the sea in the previous year), has more than once succeeded in carrying a cargo of merchandise to the mouth of the Yenisei, and getting back the same summer. The Kara Sea being thus navigable for about two months (July to September) in the year, it is hoped that it can be made available for an important trade with Siberia. Captain Hoygaard of the Danish navy urged in the *Scottish Geographical Magazine* (January 1890) that this would be the most feasible route whereby to reach the North Pole.

Karategin, a country of central Asia, forms the easternmost province of Bokhara, and has the Russian province of Ferghana (Khokand) on the north. It is a highland region (6000-7000 feet), and is traversed from east to west by the Surkhab or Kizil-su, a tributary of the Amu-Daria. Area, 8310 sq. m. In winter (October to May) the climate is very severe; nevertheless much fruit and corn are grown. The people, Tajiks by race, number about 100,000, with about 5000 nomad Kighiz. The native khans claimed to be descended from one of Alexander's captains, and only lost their independence, to Bokhara, in 1868.

Karauli (*Keroulee*), a native state in Rajputana, separated by the river Chambal from Gwalior. Area, 1208 sq. m.; population, 156,587, nearly all Hindus. It is a hilly country, especially rich in timber.—The capital, Karauli, 75 miles NW. of Gwalior, is defended by a sandstone wall, 2 miles in extent. Pop. 25,607.

Karczag, a town of Hungary, formerly capital of Great Cumania, is situated 99 miles by rail E. by S. of Budapest. Pop. 15,825.

Karelia, an old name for the south-east part of Finland, annexed to Russia by Peter the Great in 1721. The Karelians properly so called are a branch of the Finnic race, about 303,000 in number, who dwell in the eastern parts of Finland and the adjoining provinces of Russia from Archangel to Tver. See Rae's *White Sea Peninsula* (1882).

Karens'. See BURMA, Vol. II. p. 564.

Karikal, the second in importance of the French possessions in India, is on the Coromandel coast, 12 miles N. of Negapatam, and has an area of nearly 53 sq. m. It is a fertile tract, well supplied with rivers and canals, and largely given up to the cultivation of rice. The pleasant little capital, about a mile from the sea, has been four times taken by the British. There is an active trade in rice, principally with Ceylon and the Straits Settlements. The annual revenue is about £16,000. Pop. (1895) 60,376.

Karli, a Chaitya temple cave in Bombay Presidency, on the road between Bombay and Poona. In front stands a lion pillar, supporting four lions, and bearing an inscription which ascribes its date to the 1st century B.C. The outer porch, 52 feet wide, is closed by the remains of a screen. The dimensions of the interior are 126 feet by 45 feet 7 inches, the height being not over 45 feet. The building consists of 'a nave and two side-aisles, terminating in an apse or semi-dome, round which the aisle is carried.' All the pillars are octagonal, the seven behind the dagoba or 'Tape (q.v.) being plain, but the fifteen on either side of the nave having richly ornamented capitals bearing elephants and human figures, all admirably executed. Over the entrance is one great window in the form of a horseshoe directing the light mainly on the dagoba. See Fergusson, *History of Indian Architecture*.

Karlings. See CARLOVINGIANS.

Karlsbad. For Karlsbad, Karl-krona, Karls-miie, &c., see CARLSBAD, &c.

Karlsburg (Hung. *Gyula-Fehervar*), a town and fortress of Transylvania, near the Maros, 170 miles E. of Szegedin by rail. Pop. 7388.

Karma. See BUDDHISM, Vol. II. p. 518.

Karmathians. a religious and communistic sect into which the Ismailis (q.v.) developed in Asia under the lead of Hamdan Karmat, a peasant-prophet in the region of Kufa. The secret society soon organised itself and began a formidable peasant war. Bahrein was overrun, and in 900, under Abu Saïd, the Karmathians took Hajr, north-east of Yambou, and made it their capital. Damascus had to ransom itself; Badbec was taken and its inhabitants put to the sword. Abu Saïd's son, Abu Taher, succeeded him. In 923 he took and plundered Bassora; next year he plundered a caravan of 20,000 pilgrims returning from Mecca; and in 925 captured and plundered Kufa, killing or enslaving the inhabitants. In 930 during the Hajj he took Mecca, killing 30,000 persons, choked the well Zem Zem with corpses, and carried away the black stone. Then he threatened Bagdad with only 500 horse from among his 107,000 armed zealots. During the next eight years there was no Hajj, but it was resumed on a payment of 25,000 dinars by the calif to Abu Taher. This leader died in peace in 943, leaving the control of religion and politics to a council of seven. After a twenty-two years' absence the black stone was brought back to Mecca by the Karmathians and ransomed. During the next hundred years the sect gradually succumbed to the sword and to natural causes, but not until it had acted as a powerful dissolvent on the califate.

Karnac. See THEBES.

Karnal. capital of a district in the Punjab, India, 7 miles W. of the present course of the Jumna, and on the Western Jumna Canal. The population decreased from 27,022 in 1868 to 23,133 in 1881, and to 21,963 in 1891.

Kärnthen. See CARINTHIA.

Karnul. a town in Madras Presidency, India, 110 miles S. by W. from Haidarabad (Hyderabad). Fever is endemic. Pop. (1871) 25,579; (1891) 24,576. The district separated on the north by the Krishna from the Nizam's dominions - contains 2440 sq. m., and in 1891 had a population of 683,718. The canal of the Madras Frigate Company traverses it for 140 miles. Karnul suffered very severely during the famine of 1877-78.

Karr. JEAN BAPTISTE ALPHONSE, a French novelist who long survived his popularity, was born at Paris, November 24, 1808. He was educated at the College Bourbon, and early devoted himself to journalism. His *Sans les Tillands* (1832), the outcome of a disappointment in love, by its originality and wit found its author an audience for a long series of novels, of which *Genevieve* (1838) only need be mentioned here. In 1839 he became editor of *Figaro*, and in the same year he started the issue of *Les Gouges*, the gay and brilliant but sometimes bitter satire of which brought him many readers, no little ill-will, and attempted assassination from a woman's hand. These papers he collected in seven volumes (1833-57)—an attempted revival of the series subsequently to 1870 proved a miserable failure. In 1855 Karr went to live at Nice, where he occupied himself with gardening. His *Voyage autour de mon Jardin* (1845) is one of his best-known books. His *Oeuvres complètes* were collected in 1860. He died September 30, 1890.—His daughter, THÉRÈSE KARR (born 1835), has published tales and historical books.

Karoo. a generic name given to the high plains of Cape Colony. But the word is more usually associated with the Great Karroo, the elevated basin, more than 3000 feet above sea-level, and 350 miles long by 70 to 80 wide, which lies between the Nieuweveld Berge on the north and the Zwarte Berge on the south. It is not a sandy desert; after rain its rich red soil is covered with a thick carpet of grass and flowers. Nevertheless, during nine months of the year, when rain does not fall, it has a parched, barren appearance. Large herds of sheep and goats (Angora), with smaller flocks of ostriches, cattle, and horses, are pastured on it during the season of grass. The dearth of water is now being in some parts obviated by windmills and wells for procuring the water that is generally found at some distance below the surface. Two centuries ago this district was a perfect paradise for game, which even yet is not quite extinct. See H. A. Bryden, *Kloof and Karroo* (1889).

Kars. a fortress of Russian Armenia, lies about 110 miles NE. of Erzerum. It is situated on a tableland of upwards of 6000 feet in elevation; the climate is therefore rather severe. Pop. (1890), since the Turks and Lazes have migrated to Turkey, 8672, mostly Armenians, who carry on an active transit trade. In 1828 Kars was taken from the Turks by the Russians under Paskevitch. It was brilliantly defended by the Turks under General Williams for six months in 1855. At the beginning of the war of 1877-78 Kars was invested by the Russians, but relieved in July by Mukhtar Pasha; besieged again in the autumn, it was carried by storm on 18th November 1877 by General Lazareff. Kars, long a bulwark of the Ottoman empire in Asia, was one of the Armenian fortresses the cession of which to Russia was agreed to by the Berlin Congress in 1878. It forms now a commanding position from a military point of view on the plateau of Asia Minor, facilitating future aggression towards Erzerum and Turkish Armenia in general. Kars, whose fortifications have been recently augmented, is nearly impregnable. See works on the siege of 1855 by Sandwith (1856) and Laurence Oliphant (1856).

Karshi (anc. *Nakhsheb*), a town of Bokhara, central Asia, stands in a plain 95 miles SE. of Bokhara city and 80 SW. of Samarcand. It is surrounded by well-cultivated land and numerous gardens. Commercially it is of great importance in the transit trade between Bokhara, Kalul, and India. Its knives and firearms are exported to all parts of central Asia, Persia, Arabia, and Turkey. The inhabitants, estimated at 25,000, are for the most part Esbeqs, with a mixture of Tajiks, Indians, Afghans, and Jews.

Karst. See CROATIA.

Kartoum. See KHARTOUM.

Kárttikeya. the Hindu Mars, or god of war, a being represented by the Puranic legends as sprung from Siva, after a miraculous fashion.

Kárún River (Persian *Káran*: the *Uai* of Daniel, viii. 2), the sole navigable river of Persia. Rising in the Zardah Koh Mountains, near Ispahan, it flows west through gorges of the Bakhtiari Range to Shuster, the capital of the province of Arabistán, where it becomes navigable. At Ahwáz a reach of rapids and broken water bars the course of vessels to the Lower Kárún, and a canal from Ahwáz to a point about 1½ mile down stream will have to be cut before through navigation is possible. A tramway was in 1890 in course of construction for the conveyance of passengers and merchandise from the limit of navigable water to Ahwáz. Below Ahwáz the river varies in breadth

from 300 to 500 yards, and flows for 117 miles without an obstacle through a country naturally rich and fertile, but now entirely uncultivated. Mohammed lies at the junction of the Karun with the waters of the Euphrates and Tigris (*Shut-el-Arab*). As long ago as 1842 Lieutenant Selby ascended the Karun as far as Shuster, and made a report urging the importance of this waterway to English commerce. But it was not till October 1858 that, through the instrumentality of Sir Henry Drummond Wolff, then British minister at Teheran, the navigation was thrown open by royal proclamation not to England only but to the commerce of the world. It is difficult to exaggerate the importance of this new trade route to Persia, to British India, or to England.

See W. F. Ainsworth, *The River Karun* (1890); *Jour. Roy. Geog. Soc.*, vol. ix, p. 26, vol. xiv, p. 219, and new series, vol. v, p. 120; and the *Times* of 4th February 1890.

Karyokinesis. See CELL.

Kasai. See KASSAL.

Kasanlik, or KEZANLIK, a town of Eastern Roumelia, at the foot of the Balkans, 5 miles from the southern end of the Shipka Pass, and 87 miles NW. of Adrianople. It manufactures otto of roses. Its capture by the Russians on 7th January 1878 led to the surrender of the Turkish defenders of the Shipka Pass. Pop. 20,000.

Kaschan (Hung. *Kassa*), one of the oldest and handsomest towns of Hungary, is situated in the beautiful valley of the Hernad, surrounded by vine-clad mountains, 130 miles by rail NE. of Budapest. The cathedral of St Elizabeth (built 1270-1468) is the finest Gothic edifice in Hungary. The town, which ranks as the provincial capital of northern Hungary, is the seat of a Roman Catholic bishop, has various schools, an agricultural institute, and a royal tobacco-factory; stoneware, furniture, starch, nails, and paper are also manufactured. Kaschan is celebrated for its hams. Of the Jesuit university founded here in 1659 all that now remains is the law academy. Pop. (1891) 28,884. Kaschan figured prominently during the Hungarian revolution of 1848.

Kashan, one of the most flourishing towns of Persia, is situated in a well-peopled, well-cultivated district, 3690 feet above sea-level, and 92 miles N. of Isfahan. The vicinity is celebrated for its fruit, particularly melons and pears, and the town for its extensive manufactures of silk-stuffs, gold brocade, glazed tiles (called all over Mohammedan Asia *kashi*), carpets, and copper-wares. It is a large town, and abounds, like all Persian towns, in mosques, bazaars, and baths. Pop. 30,000.

Kashgar, the political capital of eastern or Chinese Turkestan, and, next to Yarkand, the second place of importance, is divided into Kuhna Shehir ('old city') and Yenghi Shehir ('new city'). The town and district of Kashgar have a population of 120,000 souls. The old city is a small fortified place overlooking the Kizil River, by which it is separated from the new city, said to have been built in 1838. In this last-mentioned part of the town stands the Orda—i.e. the palace of the Chinese governor of the whole province, as well as the Friday Mosque (Juma Masjid). The people, mostly Turks, intermixed with Tajiks, Kashgaris, Hindus, and Andijanis, excel in certain branches of industry, as the making of cottons, silks, carpets, saddlery, &c., and carry on trade, chiefly with Russia through Almati and the Terok Davan Pass, a trade supported by a permanent Russian consul, the only European diplomatist in this part of Asia. Kashgar, the centre of Mohammedan learning in eastern Turkestan, is besides a famous pilgrimage place to the shrine of Hazreti Appak Khodja, who died here in 1693. The capital and

the country round it are noted for great fertility and for a variety of excellent fruits, owing to a rich irrigation derived from several rivers and canals flowing from the north and the west. Its most flourishing period embraces the time from the conquest of Arabs under Kuteiba until the appearance of Genghis Khan, from which time it experienced all the revolutions and wars raging on the confines of Islam and Chinese Buddhism. In 1758 the Chinese took possession of Kashgar, and with short interruption it has remained in their power. The last successful rebellion was that of Yakub Kushbeghi in 1864. Kashgar was visited by the mission of Sir T. D. Forsyth in 1873, resulting in a treaty between England and Yakub; but since the Mohammedan ruler was vanquished and the country retaken by the Chinese in 1877, Kashgar has been left entirely to the political and commercial influence of Russia. See Colonel Kuropatkin's *Kashgaria* (Eng. trans. from Russian, 1883).

Kashkar. See CHITRÁL.

Kashmir. See CASHMERE.

Kashoubish, a Slavonic dialect spoken by 200,000 persons near Danzig. It has been debated whether it should be regarded as a dialect of Polish, or as a form of the extinct Polabian.

Kaskaskia, a river of Illinois, rises in the east-centre of the state, flows south-west, and enters the Mississippi at Chester. Length, nearly 300 miles. On its right bank, a few miles from the mouth, is the village of Kaskaskia, which was the first capital of Illinois Territory.

Kassai, the great southern tributary of the Congo (q.v.). See also Bateman's *First Ascent of the Kasai* (1889).

Kassala, a fortified town, formerly the capital of the Nubian district of Taka, stands on a tributary of the Atbara, 260 miles S. of Suakin. It was formerly the most important commercial centre between the Nile and Abyssinia, and previous to the Mahdi's rise had a population (with garrison) of 20,000. When taken by the Italians in 1894 it had only 3000. In 1897 it was restored to Egypt under the Anglo-Italian convention, and has accordingly been garrisoned by Anglo-Egyptian troops. The re-establishment of order in the Egyptian Soudan (1898) has restored to the place something of its old importance.

Kassassin, a lock on the canal between Ismailia and Zagazig, in Egypt, 21 miles W. of Ismailia. In the Egyptian campaign of 1882, Arabi's forces were routed here August 28.

Kassel. See CASSEL.

Kastamuni, capital of a province of the same name in Asia Minor, stands 76 miles SW. of Sinope. It manufactures cotton goods, leather, &c.; its famous copper-wares are no longer made. Pop. 40,000. Here is the ancestral castle of the Comneni; the word 'Kastamuni' is said to be a corruption of 'Castra Comneni.'

Kasvin. See KAZVIN.

Katahdin, the highest mountain in the state of Maine (q.v.), 5385 feet high.

Kater, HENRY, an English physicist, was born at Bristol, 16th April 1777. Entering the army in 1799, he went out to India, and was actively engaged in the great trigonometrical survey. Ill health compelled him to return home in 1808; then, after labouring for six years in the Royal Military College, Sandhurst, he retired on half pay. He died in London on 26th April 1835. His contributions to science are chiefly to be found in the *Philosophical Transactions* between 1813 and 1832. The most important of his memoirs relate to the determination of the length of the seconds pendulum at

the latitude of London; the 'floating collimator,' an instrument for aiding the determination of the horizontal or zenith points, for which invention he received the gold medal of the Royal Astronomical Society; the British standards of length and mass; and compass needles. Conjointly with Dr Lardner, he was the author of 'A Treatise on Mechanics' in the *Cabinet Cyclopaedia*. For the emperor of Russia he verified the Russian standards of length.

Katharine. See CATHARINE.

Kathiawar, a peninsula on the west coast of India, lying between the Gulf of Cambay and the Gulf of Cutch; the Brahman and native name for it is *Sarashtra*. Politically, the name Kathiawar Agency (formed in 1822) is given to a collection of 187 states, some independent, some tributary to native princes, and some (105) tributary to the British government in India, which between them embrace the greater part of the Kathiawar Peninsula. Area of agency, 20,559 sq. m.; pop. (1891) 2,752,404. The states of the agency supply one-sixth of the total quantity of cotton exported from Bombay. The resident of the agency lives at Rajkot.

Katkov, MICHAEL NIKIFOROVITCH, Russian journalist, was born at Moscow in 1818, studied at the universities of Moscow, Königsberg, and Berlin, and for some time filled the chair of Philosophy at Moscow. In 1861 he became editor of the *Moscow Gazette*, the organ of the university, and eventually made it the most influential journal in Russia. At first an advocate of parliamentary government and reform, Katkov was converted by the Polish rising of 1863 into a leader of the Pan-Slavist movement, and a fanatical supporter of reactionary government in Russia. He was 'the apostle of national Russian ideas' in politics, and acquired an influence in the government equal to, if not greater than, that of the ministers (except the chancellor), and is said to have been mainly instrumental in determining Alexander III. to his conservative and reactionary policy. As the champion of the idea 'Russia for the Russians,' Katkov urged the complete Russification, by force if need be, of Poland and Lithuania, and of the Baltic provinces. He enjoyed an immense popularity as the representative of Russian Chauvinism. He died at Snamensky, near Moscow, 1st August 1887.

Katmandu. See KHATMANDU.

Katrine, LOCH, one of the most celebrated of Scottish lakes, in Stirling and Perth shires, 5 miles E. of Loch Lomond and 9½ W. of Callander. Lying 364 feet above sea-level, it curves 8 miles east-south-eastward, is nowhere quite a mile broad, and has a maximum depth of 468 feet, and an area of 3119 acres. It discharges through Lochs Achray and Venachar, to the Teith; and since 1859 has supplied Glasgow (q.v.) with water. Huge Benvenue (2393 feet) and Ben Van (1500) rise steeply at its lower end, whose shores are beautifully wooded, with the mountain delfile of the Trossachs beyond. Here, too, are the 'Silver Strand' and Ellen's Isle, the chief scene of the *Lady of the Lake*. Scott was often here during 1790-1809, as also in 1805 was Wordsworth with his sister Dorothy. See her *Tour in Scotland*, and Sir G. Airy's *Topography of the Lady of the Lake* (1873).

Kat River, a branch of the Great Fish River, in the Cape Colony, rising in the Didimaberg, in the fertile valley of which a Hottentot settlement was formed in 1829. It was broken up after the rebellion of 1851-52, and the valley now forms the district of Stockenström (after Captain Stockenström), with an area of 240 sq. m., and a mixed population of about 7000.

Kattimundoo, a substance somewhat resembling gutta-percha, is the milky juice of the East Indian plant, *Euphorbia kattimundoo*, used in India as a cement.

Katydid, a name applied to numerous American insects, nearly related to grasshoppers. They are arboreal in habit, and are well concealed in the foliage by their green colour. The true katydid, abundant in the central and western states, is *Cyrtophyllus concavus*, but *Microcentrum reticris* is yet commoner, and there are several other species belonging to these and other genera. In their general habit, e.g. in the 'song' to which the syllables kat-y-did refer, and in the egg-laying accomplished by the long ovipositors of the females, these lively insects resemble Grasshoppers (q.v.).

Katzbach, a river in the Prussian province of Silesia, which falls into the Oder at Parchwitz. On its banks, in the vicinity of Liegnitz, on 26th August 1813 the French under Macdonald, 80,000 strong, were defeated by Prussian and Russian troops under Blücher. The French lost 12,000 killed and wounded, and 18,000 prisoners, with 103 cannon.

Kaub. See CAUB.

Kaufmann, ANGELICA, painter, was born 30th October 1741 at Coire in the Grisons, Switzerland. Whilst still a child she painted the portraits of notabilities in Italy, and in Rome fell under the good influence of Winckelmann. In 1766 Lady Wentworth, wife of the British resident in Venice, persuaded her to go to London. There she soon became famous as a painter of classic and mythological pictures, and as a portrait-painter. She was befriended by Reynolds, and was nominated one of the very first batch of Royal Academicians. But her life was for a while embittered by a marriage (1767) into which she had been tricked by a mere adventurer. It cost her a large part of her fortune to get the marriage dissolved. In 1781 she married the Italian painter Zucchi (1729-95), and, returning to Rome, lived for her art in a circle of distinguished artists, poets, and scholars. She died 5th November 1807. Her numerous paintings are well known from engravings by Bartolozzi and others. As a painter she fails to attain to the first rank. Grace and harmonious colouring do not atone for faulty drawing and lack of originality. Angelica was also an accomplished singer. Her beauty and talents were sung by such poets as Goldsmith, Klopstock, and Gessner, and her story has in recent times furnished a theme to Miss Thackeray. See Wesley's *Life of her in Dohme's Kunst und Künstler* (1877); *Dublin Univ. Mag.*, 1873; *Art Journal*, 1890; and the *Life* by F. A. Gerard (1892).

Kaufmann, CONSTANTINE VON, a Russian general of German (Holstein) descent, was born near Ivangorod in Russian Poland, on 3d May 1818. He entered the army as lieutenant of engineers in 1838, fought against the Circassians in the Caucasus, and especially distinguished himself at the siege of Kars in 1855. In 1867 he was appointed governor-general of Turkestan, and at once set himself to organise this province, then newly conquered; in 1868 he occupied Samarcand, and in 1873 conducted a successful campaign against Khiva. Through his energetic policy Russia became the predominating power in central Asia. General Kaufmann died on 16th May 1882 at Tashkend. See Boulger's *Central Asian Portraits* (1880).

Kaulbach, WILHELM VON, a German painter, was born at Arolsen, in the principality of Waldeck, 15th October 1805, and in his seventeenth year entered the Academy of Arts at Düsseldorf.

He was one of Cornelius's best pupils, and followed him to Munich; from 1849 down to the year of his death he was director of the Academy of Painting in that city. Although painting in the severely ideal and allegorical spirit of his master, Kaubach displayed from the first no lack of individual genius. Among his first important productions were sixteen mural paintings illustrating the myth of Amor and Psyche, in the palace of Duke Maximilian, and Apollo amongst the Muses, for a ceiling in the Odeon. Then he executed a number of designs from the works of Klopstock, Wieland, and Goethe in various royal apartments in Munich. In 1834 Kaubach completed his grandiose 'Battle of the Huns,' representing the legend of the struggle, continued in mid-air, between the sons of the Huns and Romans who had fallen before the walls of Rome, which was regarded as the culmination of the new German school. Nevertheless, the realistic tendencies of his genius came out in his illustrations of Schiller, Goethe's *Faust*, and *Reincke Fuchs*, and in his 'Mad-house.' In 1846 Kaubach completed, on the heroic scale, the 'Destruction of Jerusalem by Titus.' For several years from 1847 onwards he was occupied painting the walls of the vestibule of the new museum at Berlin with a cycle illustrating the progress of civilisation. This series embraced six colossal compositions—'The Tower of Babel,' the 'Glorious Age of Greece,' the 'Destruction of Jerusalem,' the 'Battle of the Huns,' the 'Crusades,' and the 'Reformation,' with numerous smaller designs. His last gigantic painting is the 'Sea-fight of Salamis' in the Maximilianum at Munich. In his later years he composed illustrations to Goethe and Shakespeare, and painted many portraits. He died of cholera at Munich, 7th April 1874. See Mrs Howitt-Watt's *Art-Student in Munich* (2d ed. 1879).—His son, HERMANN, born at Munich on 26th July 1846, studied under Piloty, and paints historical pictures of the genre class—such as 'Louis XI. and Olivier le Dain,' 'Mozart's Last Days,' 'Carousing Knights Templars,' 'Sebastian Bach and Frederick the Great.'—A nephew, Friedrich (born 1822), and a grand-nephew, Friedrich August (born 1850), also became painters of merit.

Kaunitz, WENZELIUS ANTHONY, PRINCE VON, Count of Rietberg, Austrian statesman, was born at Vienna on 2d February 1711, and began his public career under Charles VI. Maria Theresa employed him on diplomatic missions to the courts of Rome, Florence, and Turin, and then appointed him minister to the governor of the Austrian Netherlands. He laid the foundations of his permanent fame as a diplomatist in 1748 at the congress of Aix-la-Chapelle. As Austrian ambassador at the French court in 1750-52 he succeeded in converting the century-long enmity of the two states into relations of amity and goodwill. In 1753 Kaunitz was appointed state chancellor, and in 1756 chancellor for the Netherlands and Italy, and for almost forty years continued to have the principal direction of Austrian politics. On account of the part he played in the affairs of Europe he was jocularly called the European coach-driver. As a man he was very vain and confident of his own abilities, narrow in his political views, regarding exclusively the supposed interests of Austria, yet sincere and upright according to his notions of duty. He took a very active part in the ecclesiastical reforms of Joseph II., and was always an earnest and liberal patron of the arts and sciences; he founded the art school of Vienna, and several academies in Lombardy and the Low Countries. He retired from public life when Francis II. ascended the throne, and died 27th June 1794. See *Lives* by Hornayr (in *Die österreichische Plutarch*, vol. vi.) and Beer (1872).

Kauri Pine, or KOWRIE (*Dammara australis*), a species of Dammur (q.v.), a native of New Zealand. It is a tree of great size and beauty, attaining a height of 140 feet or more, with whorls of branches, the lower of which die off as it becomes old. The timber is white, close-grained, durable, flexible, and very valuable for masts, yards, and planks. The Fiji Islands, New Hebrides, and Australia produce other species. All of them are trees of dark, dense foliage, and produce a resin called Kauri Resin, or Kauri Gum, and sometimes Australian Copal and Australian Dammur, of which large quantities are exported from Auckland. It is sometimes found in pieces as large as a child's head, of a dull amber colour, where forests of these trees have formerly grown; and is now known to lie mingled with coal strata of Tertiary age. It is also collected from the trees from which it has newly exuded, and is then of a whitish colour. *D. orientalis*, a native of the Moluccas, exudes a similar resin, which is at first white like crystal, and is called white dammur, but with age it assumes a yellow amber tint.

Kava. See AVA.

Kavanagh, JULIA, novelist, was born at Thurles, in County Tipperary, in 1824. She was the daughter of Morgan Kavanagh, an accomplished Irishman, author of various philological works, and she grew up a girl of remarkable beauty but of unusually small stature. Great part of her youth was spent in Normandy, her later life in Paris, Rome, or Nice, where she died, October 28, 1877. Her first work which attracted attention was *Madeleine, a Tale of Auvergne* (1848); of its numerous successors the best were *Nathalie* (1850), *Daisy Burns* (1853), *Adèle* (1857), *Queen Mab* (1863), *Beatrice* (1865), *Silvia* (1870), *John Dorrien* (1875), and *The Pearl Fountain* (1876). The scenes of almost all her stories are laid in her adopted country, and her studies of French life and character possess a reality and truth unhappily but seldom found in the fluent novels of foreign writers who have lightly essayed these themes. Her plots move quietly but naturally forward to the *dénouement*, and skilfully preserve the interest, if they do not feel the excitement, of the reader. Other well-known books are *A Summer and Winter in the Two Sicilies* (1858), *French Women of Letters* (1862), *English Women of Letters* (1863), *Women in France during the Eighteenth Century* (1850), and *Women of Christianity* (1852)—a work which reveals beautifully the sympathetic and religious nature of its authoress, herself a devout Catholic.

Kaveri (*Cauvery*), a river of southern India, rises in the Western Ghâts, and flows south east, across Mysore and Madras, to the Bay of Bengal, which it enters through two principal mouths. Length, about 475 miles; drainage, about 28,000 sq. m.; flood discharge above the delta, 472,000 feet per second. The Kaveri is of no value for navigation, its bed being rocky, with numerous rapids and falls—as those at the island of Sivasamudram, in Mysore, famous for their romantic beauty. Other islands formed by this river are Seringapatam, in Mysore, and Srirangam, just above the delta. It is of importance for irrigation in Mysore and in Coimbatore district, but especially in the marvelously fertile delta. For this purpose the main stream has been dammed since the 4th century A.D., the Coleroon (the northern branch) since 1838.

Kawi, a language of Java (q.v.).

Kay, JOHN, a famous Scotch caricaturist, was born near Dalkeith in 1742, and from an early age practised prosperously as a barber in Edinburgh, until in 1785 he opened a print-shop for the sale of miniatures and sketches of local celebrities etched

by himself. He died February 21, 1826. Kay's portraits have but little artistic merit beyond a genuine humour, yet he possessed somehow the trick of catching the likenesses of his subjects, and the series forms a unique and invaluable record of the social life of the Edinburgh of his time. His portraits were collected and published as *A Series of Original Portraits and Caricature Etchings by the late John Kay, with Biographical Sketches and Illustrative Anecdotes* (2 vols. quarto, 1838; new ed. with additional plates, 2 vols. 1877).

Kayak. See ESKIMO.

Kaye, SIR JOHN WILLIAM, the historian of English India, was born in 1814, and educated at Eton and Addiscombe Military College. He served for some years in the Bengal Artillery, but retired in 1841 to devote himself to literature. In 1856 he entered the service of the East India Company in England, and, on the transfer of the government of India to the crown, was appointed to succeed John Stuart Mill as secretary in the Political and Secret Department of the India Office, a post which he retained until failing health obliged him to retire in 1874. Three years before he had been knighted, and two years later he died, July 24, 1876. Kaye's works are *The History of the War in Afghanistan* (4 vols. 1851-53); *History of the Administration of the East India Company* (1853); *The Life and Correspondence of Sir John Malcolm* (1856); *Christianity in India* (1859); *History of the Sepoy War in India in 1857-58* (2 vols. 1866-71); and *Essays of an Optimist* (1870). His account of the mutiny struggle has given rise to much embittered controversy, but despite its faults is a noble monument of historical industry and insight. A revised edition of the *Sepoy War*, along with Colonel Malleon's history of the Indian Mutiny, together forming a connected history, was completed in 6 vols. in 1890.

Kayes, or KHAYES, a town of the French Soudan, on the river Senegal, is the terminus of the railway being constructed from St Louis in 1890. Pop. 6000.

Kay-Shuttleworth, SIR JAMES. See EDUCATION, Vol. IV, p. 211.

Kazan, capital of the Russian government of Kazan, and anciently capital of the Mongol kingdom of the Golden Horde, stands 3 miles from the north bank of the Volga, and 200 miles E. by S. from Nijni-Novgorod. The Mongol kingdom was founded in the middle of the 15th century on the ruins of the still more ancient Bulgarian empire (see KIPCHAKS). At the same time the modern city of Kazan was built 28 miles SW. of the former city. In 1552 the Russians, under Ivan the Terrible, carried the town after a bloody siege, and put an end to the Mongol kingdom. The kremlin or fortress embraces within its walls the cathedral (1552), which has a wonder-working icon of the Virgin, a magnificent monastery (1555), an arsenal, &c. The houses are in general one storied, and stand in the midst of gardens. The town has nearly fifty churches, a dozen mosques, and the Sumbek Tower, an object of veneration to the Tartars. Kazan is the chief intellectual centre of eastern Russia, and a home of oriental study. The university, founded by Alexander I. in 1804, has four faculties and nearly 1000 students; the institutions connected with it include a library of 80,000 vols., an observatory, a botanical garden, an antiquarian museum, &c. Kazan is the seat of a Greek archbishop. The principal objects of industry are leather, soap (made from mare's milk), candles, gunpowder, books, hempen goods, cotton, sacred pictures, &c. Close to the town are the shipbuilding-yards in which Peter the Great built his Caspian

Sea fleet. The Tartar merchants of Kazan trade as far as Bokhara and Persia on the one side and to Asia Minor on the other. The central parts of the town are occupied by Russians; the Tartars dwell for the most part in the suburbs. Pop. (1871) 86,262; (1895) 140,726. The town was destroyed by fire during Pugatcheff's rebellion (1774), and has suffered severely from the same cause more than a dozen times, especially in 1815 and 1825.—The government, lying west of that of Nijni Novgorod, is traversed by the navigable Volga and Kama, with their tributaries. The 'black earth' soil produces rye and oats, with other crops, agriculture being the main occupation of the people. One-third of the total area (24,594 sq. m.) is under forest. Pop. (1871) 1,739,909; (1887) 2,113,954; (1895) 2,231,957.

Kazbek, or CASBECK. See CAUCASUS.

Kazvin, a town of Persia, 95 miles NW. of Teheran, on the road to Resht, manufactures brocade, velvet, cotton, and iron-ware, and breeds camels and horses. Kazvin has obtained a new commercial importance through the opening of the Transcaucasian Railway: the route connecting Persia with Europe goes by Kazvin to Resht and Baku, and to facilitate this communication a *chaussée* has been constructed from Teheran to Kazvin. Pop. 40,000.

Kea is the native (New Zealand) name for a genus of parrots, of which only three species are known; these are *Nestor notabilis*, *N. meridionalis*, and *N. productus*, which last appears to have just become extinct. *N. notabilis* is a mountain species, confined to the South Island; it was originally a vegetable and insect feeding bird, but on the introduction of sheep it began to frequent the stations and to feed on offal; later on the parrot acquired the more objectionable habit of destroying live sheep. A number of birds band themselves together and hunt out a weakly member of a flock, generally at night. The sheep is worried to death by the combined efforts of the parrots, which then proceed to devour the kidney fat. This is one of the most remarkable instances known of a rapid change of habit.

Kean, EDMUND, actor, was born in London, in Gray's Inn, 4th Nov. (some authorities say 17th Mar.) 1787. His parentage also is doubtful, for, though it is tolerably certain that Nance Carey, daughter of George Savile Carey, was his mother, it is quite uncertain who his father was. Kean is said to have declared himself to be an illegitimate son of the Duke of Norfolk, but common tradition assigns to him as parent either a tailor named Aaron Kean or a builder named Edmund Kean. Nance Carey being an actress, Kean from his infancy made occasional appearances upon the stage, and when about sixteen years old became a regular 'stroller,' playing in Richardson's show and other temples of the itinerant drama. After ten years' painful experience in various provincial circuits he succeeded in obtaining an engagement at Drury Lane Theatre, where he made his famous first appearance as Shylock on 26th January 1814. His success was immediate, and he at once took rank as the first actor of the day, displacing even John Philip Kemble, whose powers were by this time declining. A period of wonderful success followed; but unhappily Kean's irregularities were as great as his genius, and he gradually forfeited the public approval, his reputation being finally ruined by the *cause célèbre* of Cox v. Kean (January 1825). In this wretched case Kean was found guilty of misconduct with the wife of one Alderman Cox; and, although he seems to have been at least as much sinned against as sinning, a strange outburst of popular morality literally drove him off the stage, Edin-

burgh particularly distinguishing itself in vigorous denunciation of the unfortunate actor. Kean then paid a long visit to America, where he had on a previous visit been very popular. He remained in America till the end of 1826, and on his return home was cordially received; but both mind and body had given way in his wild career, and he was the mere wreck of his former self. At last, on 25th March 1833, he broke down hopelessly, while playing Othello to the lago of his son Charles, and never acted again. He died at Richmond on 15th May 1833. Regarding Kean's genius as an actor there can be no question. He was a master of passionate expression, and excelled in characters where the emotions are kept at highest tension. In level passages he was absolutely bad, and had no power to represent calm dignity; but in the mental agony of Othello, the wild passion of Shylock, or the cynical devilry of Richard he was unapproachable. No better idea of the irregular grandeur of his playing can be given than is contained in Coleridge's saying, that 'seeing Kean act was reading Shakespeare by flashes of lightning.' Kean's life has been written by Barry Cornwall (1835), F. W. Hawkins (1869), and J. F. Molloy (2 vols. 1888).

CHARLES JOHN, son of the foregoing, was born at Waterford, 18th January 1811. He was educated at Eton for one of the learned professions; but his father's extravagances and dissipations rendered it necessary that he should leave school and do something to support his mother and himself. He accordingly became an actor, in spite of the bitter opposition of his father, who swore that he himself would be the first and last tragedian of his name. Charles Kean made his first appearance, at Drury Lane, on 1st October 1827, in the character of Young Norval, and was received by the critics with almost universal condemnation. But he worked assiduously in the provinces, and studied hard, until in time he attained a fair position in his profession, his efforts being greatly aided by the genius of Ellen Tree, whom in 1842 he married. In 1850 Kean became joint-lessee with Keeley of the Princess's Theatre in Oxford Street, London, and here he produced the long series of gorgeous 'revivals' which were the most conspicuous feature of his career. In these, it is to be feared, upholstery was more studied than acting. In 1859 he retired from management, and virtually from the London stage, though he played in America and the provinces to within a few months of his death. His last appearance was made in Liverpool on 29th May 1867, and he died in London 23d January 1868. His wife died 21st August 1880. As a tragic actor Kean was not in the first or even the second rank, but he was admirable in melodrama, and his acting in such plays as *The Corsican Brothers* and *Louis XI.* could scarcely be surpassed. See his Life by J. W. Cole (2 vols. 1860).

Kearsley, a town of Lancashire, 4 miles S.E. of Bolton. Pop. 7253. In the neighbourhood are coal-mines and paper-mills.

Keary, ANNIE, novelist, was born 3d March 1825, at Bilton, in Yorkshire, where her father was rector, having sold out of the army and taken orders after the loss of his estate in County Galway. Her sympathetic insight into the hearts of children gave her the first impulse to write, and made the success of *Little Wanderlin* and the *Heroes of Asgard* (written together with her sister Eliza), as well as the later books, *A York and a Lancaster Rose*, *Mia and Charley*, and *Real Keays*. She spent her life at Hull, Trent Vale in Staffordshire, London, Brighton, and Eastbourne, wintering twice near Cannes and once in Egypt. Of a sensitive and impressionable temperament wedded to a

strong understanding, she passed through a troubled spiritual experience, but found rest in a fervent Christianity with unwearied devotion to her friends and to the poor. She died after a year's illness at Eastbourne, 3d March 1879. Two admirable books outside her usual province were *Early Egyptian History* and *The Nations Around*. Her first novel was *Through the Shadows*, and this was followed by *Janet's Home*, *Clemency Franklyn*, and *Oldbury Castle Daly*—was hailed as an Irish novel of unusual excellence—while writing it she paid the island the one brief visit of her life. Her latest work, and perhaps her greatest, was *A Doubting Heart*. See the Memoir by her sister (1882).

Keats, JOHN: Oct. 1795—Feb. 1821. Youngest to rise and earliest to set in that brilliant constellation of poets who ennobled England during the first half of the Nineteenth century, John Keats, both in himself and in his work, is one of the most profoundly interesting and attractive figures in literature. In character, true, magnanimous, modest, and tender; much tried and rarely failing; throughout training himself sedulously for the highest achievement in poetry—his life, as man and as artist, was one of persistent growth onward and upward. It is to trace this development, under both aspects, that the following narrowly limited sketch will be mainly devoted.

John Keats was born in Finsbury, London, son of a respectable livery-stable keeper; sent early to school at Enfield, where an elder boy, Cowden Clarke, turned his boyish energies at thirteen towards literature. Henceforward Keats read much and widely. Greek, like Shakespeare, he never learned, but eagerly studied manuals of classical mythology; in Latin he began and (after leaving school) finished a prose version of the *Æneid*; and we cannot doubt that his passion for melody, felicity of phrase, tenderness and beauty in style, was developed or inspired by Vergil's unequalled magical art. Quitting school in 1810, Keats was first apprenticed to a surgeon; then, till 1817, practised diligently in London, and, (for his age), with success. But poetry had now become paramount; and his high sense of duty withdrew him from a profession demanding imperiously a man's entire devotion.

By 1816-17 Keats had found many friends and associates; notably Leigh Hunt, Haydon, Hazlitt;—men of early promise, and (Hunt and Hazlitt at least) of real ability, though sadly marred or blighted by bad taste, vanity, and weakness. His youth naturally led Keats at first to accept their self-estimate and hence overrate their worth and powers. Morally and intellectually he could gain little, except some genial literary impulse, from natures so inferior to his own; yet though familiarity in time cooled, he remained loyal to their better qualities. His friendship was also sought by Shelley. Their names have been united through *Adonais*; but the wild eloquence, the chill Auroral splendour of that great Elegy display no truth in the portraiture of Keats, no touch of human pathos. The two men were in fact, (generally speaking), antagonistic in nature, principles, conduct, and ruling ideas upon that art in which both were so richly gifted; and hence familiarity, on the part of Keats, now and later, was impossible. Others of less note, Reynolds, Dilke, Armitage Brown, were more to Keats; but above all his intense unwavering affectionateness, (one of several points in which he resembles Catullus), placed his two brothers and sister by far highest in value.

This was the poet's student period. Vergil was his first perhaps his most influential love. Clarke led him to Spenser at the close of 1813. Homer in the fine extravagance of Chapman's version, Chaucer, Shakespeare, Milton, Words-

worth, — 'the best sort of poetry' as he said, *color che sanno*, became his bosom-friends. Yet, except in early years, he imitated none: Literature has no poet more decisively original.

Thus far Enfield and Hampstead (then unspoiled) were the landscape, the free nature, whence visions of beauty had been created by the young poet's observant eye, ever 'on the object,' and his vivid imagination. But having (March, 1817) published his first book, Keats found 'pastures new' at Carisbrooke, in the island now for near forty years a home of the one modern poet in whose genius we may trace a certain congenital likeness to his own. Here Keats worked at *Endymion*; but solitude was fever to that tropically developing nature; financial anxiety also, (so badly was his slender fortune handled by a guardian), which never wholly left him, threw the first eland of dejection over his sensitive spirit; and he returned to Hampstead and his friends. Eminent among these was now Bailey, then studying at Oxford, where Keats visited him during Long Vacation, continuing *Endymion* upon the Isis. This may have been the sunniest moment of his life. Bailey was apparently the friend who called out what was best and deepest in Keats: It is he also who has left us the most charming sketch of his conversation: (*Colvin*, p. 76).

In 1818 Keats frequently saw Lamb and Wordsworth, whose poetry, (the *Excursion* especially), amongst that of his contemporaries, most deeply affected him. To nurse his much-loved brother Tom, rapidly failing under consumption, he now moved to Teignmouth; *Endymion* was finished; *Isabella*, for his third volume, began.

These were the last good days allotted to Keats. His character and his aims as Poet were now formed; both have been much misinterpreted; let us here attempt to summarize them. Manliness, magnanimity, unselfishness, force of human affection, chivalry to woman, — are the dominant notes of his nature: Hatred of wrong and meanness, insight and generosity in act and judgment: — and all guided by eminent good sense; Personally proud; — as to his abilities and work, almost pathetically humble-minded. Keats was no sensualist, as has been erroneously reported; no vague idealist; for the first too unselfish, too clear headed for the latter; and from perversity, instability, and self-conceit singularly free.

A man's art is inevitably conditioned by his nature. From that of Keats, sensitive yet strong, modest yet aspiring, when we add a freshness and fullness of genius which recalls Chaucer and Shakespeare, we might justly anticipate that he would not fail to grasp the true idea of poetry under its main heads, the interpretation of nature and of humanity, — both always subordinate to beauty in sound, words, and form. And we find that it was in such wise that Keats, like Sophocles and Pindar, Vergil and Milton, consciously or not, regarded poetry. He was an artist in the rarest and truest sense; this makes him so noteworthy; it is this, not *Endymion* or *Hyperion*, (which ranks him with the Greeks. Pursuing Beauty always as his goal, its sensuous charm, in melody and in wealth of description, — an impulse natural to a youth so gifted — often largely over-dominates his verse to 1818. Yet this style from the first he felt was but the prelude to the higher Muses; the transit from Euphrosyne to Urania. Keats was in truth as exquisitely human as Shakespeare; already in the final piece of his first book he is hoping to quit the mere joys of poetry

for a nobler life,
Where I may find the agonies, the strife
Of human hearts.

By 1818, in an admirable letter comparing Life to

a many-chambered house, he notes how he has passed from Maiden-thought, — the bower of youth, pure yet pleasure-devoted, — to a place of darkness: 'We feel the *Burden of the Mystery*.' Hence, though he dares not yet 'philosophise,' he finds that the only worthy pursuit is the 'idea of doing some good to the world:' that he 'can have no enjoyment . . . but continual drinking of knowledge:' he rejoices that he has kept his old medical books. This feeling gradually masters him: 'Scenery is fine, but human nature is finer:' his longing is, not for vain praise, but for 'the glory of making, by any means, a country happier.' That these were not mere words, the details of his life prove: whilst some realization of his hopes in poetry is given by the volume of 1820. And if, by twenty-four, he was only beginning to handle the higher human interests; yet may we not truly say that his country has been made lastingly happier by what Keats did thus leave us?

Returning to the story: Henceforth, in quick sequence, the shadows deepen. George Keats departed for America: John to the Lakes and Western Scotland, where what was to prove consumption, developed by overfatigue, claimed him. Then, (Dec. 1818) came the death of his brother Tom: Last, the passion of first-love for Miss Fanny Brawne. They became engaged; but it was too late: — Poverty, bodily decline, and above all his own intensely loving heart, morbidly anxious, gradually changed what should have been support and comfort to agony. Yet Keats struggled bravely. As if purified by the trial, his genius now rapidly bore its ripest fruit: almost all that his third volume contains — the 'treasures for ever' he bequeathed us — were written between Hampstead, Shanklin, and Winchester before Autumn, 1819. Even yet he hoped to live by literature; but, returning to Hampstead, health of mind and body began unmistakably to fail: the fatal sign of lung-bleeding appeared in February 1820. Except the one swan-song of the last sonnet, henceforth it is in letters only — letters which throughout his life often rival his poetry itself in loveliness and surpass it in depth of thought — that the sorely-charged heart finds expression.

In September Keats sailed for Italy; the sad and honourable care of nursing him taken by a young artist and friend, Severn. From Naples they moved to Rome. There even the faint delusive sun-gleams of consumption were soon overclouded. It is a relief to the gloom that the generous wounded spirit now found meet reward from Severn's devotedness. Nearing death, the vague 'sentimental optimism' which formed Hunt's substitute, and perhaps his, for religious faith, proved unavailing: Keats 'contrasting now the behaviour of the believer Severn with his own, acknowledged anew the power of the Christian teaching and example, and bidding Severn read to him from Jeremy Taylor's *Holy Living and Dying*, strove to pass the remainder of his days in a temper of more peace and constancy.' (*Colvin*.)

So, though the bodily suffering and agony of remembered love were intense, calm came at last. 'He lay quiet, with his hand clasped on a white cornelian, one of the little tokens' his Fanny 'had given him at starting.' Thus, 'lovable and considerate to the last, — humbly, after his wont, not (as misinterpreted) bitterly, he spoke of his own work and name as 'writ in water:' until with a 'Thank God, it has come,' his soul resigned itself to Him in peace: (23 Feb. 1821.)

Keats lies within the Aurelian Wall of Rome on its southern side, where the faithful Severn was also buried in 1879.

As 'Maker,' Keats presents two main aspects: he is far more an artist in the highest sense than most

modern poets: He has also left us masterpieces in that style of art which his few years allowed him finally to reach. The development of his character and general aims in poetry has been traced; the parallel advance in his writing will be now briefly noticed.

The earliest volume (1817) is frankly experimental. Spenser apparently unseated the spring of poetry for Keats; yet his three imitative pieces, although Spenserian in musical flow and wealth of imagery, are coloured everywhere (in common with a few short lyrics) by the sentimental tone of the later Eighteenth century, and by slipshod mannerisms caught from Hunt. The tender chivalry of his nature glows through the technical inexperience of the *Ode to Woman*: Some trochaic lines prelude to his later success in that rare and difficult metre. Several among the sonnets rise much higher; that on Chapman's Homer alone in the volume shows his final mastery. Most interesting however are five poems in the free, lovely, heroic metre of Chaucer and the Elizabethan dramatists. Here, dashed with youthful extravagance, bad taste, and confused metaphor, we find that 'fascinating felicity' that 'perfection of loveliness' in the interpretation of Nature—(yet Nature externally viewed, without reference to her inner or human meanings)—which, in Matthew Arnold's estimate, is not less than Shakespearian. Delight in beauty for its own sake only is the leading note; yet while he wrote Keats had before him the image of Poetry by Raphael (in the Vatican fresco),—with her outstretched wings and eager glance over *Things that her scarce could tell*—things that lift the thoughts of men; and acknowledges with candour that these spiritual depths and heights of the art are as yet beyond him.

Endymion, (1818), that 'feverish attempt, rather than a deed accomplished' (so, with his delightful union of modesty and clear judgment, Keats named it), in its main features of style carries on the work of 1815-17. We have the over-sensuous pictures, the fanciful and even tasteless coinage of words; but also the myriad felicities of touch; the 'morning freshness' of Chaucer; many passages of splendid vividness. Though the subject be Greek, the treatment lacks Greek sobriety, finish, unity: It is Elizabethan-Romantic. The ground-legend is hardly traceable; a vague allegory may underlie the whole—but the serious purpose of the mediæval allegorists and Spenser, but moral beauty, are wanting.

Two years only separate *Endymion* from the concluding, the treasure-volume of 1820. Keats in this is not yet wholly disengaged from youthful exuberance; Even *Lamia*, his last and strongest poem, is too Asiatic; *Hyperion*, with pictures of un-rivaled magnificence, fails in Epic unity and interest. That supreme beauty, never attained except when it interprets human life in its misery and its greatness, is rarely touched. Yet the growth everywhere is tropical; and praise would be idle for the dignity and tenderness of the Odes, the pictorial splendour, the affluence of charm diffused throughout this little volume. One of Pindar's noblest lyrics, we read, was written in gold upon the walls of a Grecian temple. And not a few of the poems now before us might deserve a like honour.

Keats published only the three volumes of 1817, 1818, 1820, and in one edition each. An absolutely literal reproduction of them, (the reprints to 1883 teeming with errors), with notes, has been edited by the writer; including a few first-rate pieces from the great mass of incomplete and inferior work, withheld by Keats himself, but made public by the cruel kindness of admirers.

See the Lives by Lord Houghton (1848) and Selby

Colvin (1886); the Letters, edited by Mr Colvin (1891); and the *Poems*, edited by Drury (1896).

Keble, JOHN, son of the Rev. John Keble of Cohn St Alwyns, Gloucestershire, and Sarah Maule, a lady of Scotch descent, was born at Fairford, near his father's living, on April 25, 1792. His father, a divine of the school of Ken, educated his son at home, and with such success that at the unusually early age of fifteen he was elected to an open scholarship at Corpus Christi College, Oxford, then a small college, but numbering among its scholars many who rose to eminence in after-life, such as Sir J. T. Coleridge and Dr Arnold of Rugby. His university career was unusually brilliant, for in 1810 he gained a first-class both in classics and mathematics; in 1811 was elected Fellow of Oriel College; and in 1812 gained both the Latin and English prize essays. In 1815 he was ordained deacon, and priest in the following year, beginning active work as the curate of East Leach, near his father's living, while still continuing to reside in Oxford, taking pupils and examining. From 1818 to 1823 he was tutor of his college; but his heart was mainly in parish work, and his mother's death was the occasion which made him leave Oxford and return to assist his father. There in the country he did a work for Oxford and the church which was of the most vital importance. Three points need specially to be singled out in this work. (1) First in time comes the influence of his poetry. In 1827 he published with much diffidence, and only in deference to the wishes of his friends, *The Christian Year, or Thoughts in Verse for the Sundays and Holidays throughout the Year*. The influence of this volume was not very great at first, but its excellence was recognised by true critics, and later on, when the Tractarian movement had made its writer well known, and had stirred a deeper interest in its theme, it had an influence which can scarcely be overrated. For, though some of the poems are rather obscure and somewhat constrained and artificial, as though written to complete the series, yet the greater number have a genuine ring of inspiration in them; the love of home life and of nature, a calming, soothing sense of the ever-present love of God, a sobriety of religious feeling, and a sad undertone of grief for the moral and spiritual degeneracy of the church are its most striking characteristics. His own theory of poetry

that it is the vehicle for the expression of the poet's deepest feelings, controlled by a certain reserve—was explained in an interesting article in the *British Critic* in 1838 on Lockhart's *Life of Sir Walter Scott*. It was worked out at length and illustrated by an examination of the chief Greek and Latin poets in his Latin lectures delivered as professor of Poetry at Oxford, an office which he held from 1831 till 1841.

(2) His intercourse with Oxford was thus kept up, and at the end of 1827 many of his friends wished to see him elected to the vacant provostship of Oriel, and he himself would willingly have accepted such a recall to Oxford. It became, however, clear that a majority was in favour of Dr Hawkins, and Mr Keble withdrew his candidature. But meanwhile a movement was in progress which was to affect Oxford to its centre. Mr Keble had gathered round him in his ennoce a small knot of pupils, of whom the most striking was Hurrell Froude. In that knot was formed the impulse which generated the Tractarian movement. Starting from the desire for a moral and spiritual revival of the English church, revolting from the defects of learning and of taste which characterised the Evangelicals, and much more from the secular Erastianism of the dominant Whig party, these friends fell back upon the primitive ideal of

the church, emphasising its essentially spiritual character, laying stress on the reality of the apostolical succession, of the prerogatives of the priesthood, of the grace conferred in the sacraments, and insisting on a high spiritual ideal of life. In his sermon on National Apostasy (1833) Keble gave the signal for active movement, and for the next few years was busily engaged with Newman, Pusey, I. Williams, T. Keble, and others in the issue of the *Tracts for the Times*, until the series was brought to an end by the publication of Tract No. 90 in 1841. Meanwhile Keble had in 1835 married Miss Charlotte Clarke, the daughter of an old friend of his father, and had removed to the living of Hursley, where he remained until his death.

(3) Keble had not only been one of the originators of the movement; he was also, with Dr Pusey, the steady influence which supported it under the shock caused by Newman's secession to Rome. For the last twenty years of his life he was the trusted correspondent and confessor of many who were in intellectual and spiritual anxiety. He was the constant champion of the church at each critical moment, taking a prominent part by his pamphlets, especially on questions connected with marriage and divorce, with the nature of Christ's presence in the eucharist, and with the independence of the church tribunals. He also contributed much to the cause of theological knowledge by his careful edition of Hooker's works, his life of Bishop Wilson, and his translation of St Irenæus. Perhaps even more than in any of his writings he has influenced the church by his character. The type of dutifulness, whether to parents or to his church, full of affection for home life and of reverence for children, generous to his friends, chivalrous and almost Quixotic in his desire to sacrifice himself for the cause of the truth, indignant against injustice or disloyalty, with an indignation tempered by severe self-restraint, and ever striving after a deep humility, he created an impression of saintliness, and won for himself a rare mixture of love and reverence. He died at Bourne-mouth on March 29, 1866. Besides the works mentioned, he published the *Lyra Innocentium*, *Thoughts in Verse on Christian Children* (1846), a poetical translation of the Psalter, and many theological pamphlets. Since his death have been published a most valuable volume of *Letters of Spiritual Counsel*, twelve volumes of parochial sermons, occasional papers, reviews, *Studia Sacra*, &c. A permanent memorial to him exists in Keble College, Oxford, erected by subscription after his death, and incorporated on June 6, 1870. This was founded on the lines of the report of a committee, in which he himself had been much interested, for extending the university by the building of a new college on more economical principles; and it aims at providing an academic education, at a less cost than the older colleges, for members of the Church of England.

See *Memoir of Keble*, by Sir J. Coleridge (1869); J. C. Sharp, *Essay* (1896), and his *Studies in Poetry and Philosophy* (1872); also a collection of memorials by J. F. Moor (1866); and a short Life by the present writer in 'English Leaders of Religion' (1893).

Keckskemet, a Hungarian town on a plain 55 miles by rail SE. of Budapest. Pop. (1890) 48,493.

Kedah. See QEDAH.

Kedron, or KIDRON, spoken of as a 'brook' in the English Bible, should rather be called (as in John, xviii. 1, new version, margin) 'ravine' or 'winter-torrent.' It is a gorge close to Jerusalem (q.v.) on the east, running away in the direction of the Dead Sea. Water never flows in it, save during the heavy rains of winter. At other times it is a dry *wady*.

Keelhauling, a punishment in use in the navy during the 17th and 18th centuries. The culprit was suspended from one yard-arm, then suddenly dropped into the water, and hauled beneath the keel up to the yard-arm on the other side. This was the mode adopted on large square-rigged vessels. On small fore-and-aft vessels the delinquent was let down over the bows, and was drawn aft underneath and along the keelson by a hauling-line, and brought up at the rudder-chains. (Cf. Marryat's *Dog Fiend*.) Keelhauling was practised on an Egyptian corvette so recently as August 1882.

Keeling (or KOKOS KEELING) **Islands**, a group of more than a dozen coral atolls in the Indian Ocean, 12 S. lat. and about 500 miles SW. of Java, are attached to the Straits Settlements, are covered with cocoa-nut palms, whence oil is extracted, and are inhabited by about 400 Malays, but owned by a Scotchman named Ross. Pigs and rats are the only mammals; there are no land-birds but poultry; crabs, large and small, abound. These islands were discovered by Captain Keeling in 1609 and were visited by Darwin in 1836; it was upon his study of them that he based his subsidence theory of the formation of coral-reefs (see CORAL). Guppy in 1888 found here confirmation of Murray's view. See CORAL.

Keene, a pretty town of New Hampshire, the capital of Cheshire county, on the Ashuelot River, 92 miles by rail NW. of Boston. Pop. 6784.

Keene, CHARLES SAMUEL, an inimitable artist in black and white, born of Ipswich ancestry at Hornsey, 10th August 1823, was educated at Bayswater and Ipswich, and, having tried both law and architecture, was at nineteen apprenticed to a wood-engraver. He worked for *Punch* from about 1851 to within five months of his death at Hammer-smith, on 4th January 1891. See Life by G. S. Lazard (1893), and *The Work of John Keene*, by Pennell and Chesson (1897).

Keep. See CASTLE.

Keeper, or LORD KEEPER OF THE GREAT SEAL, one of the great offices of state, practically merged since 1757 in that of Lord Chancellor (see SEAL). An act was passed at the instance of Sir Nicholas Bacon, lord keeper, assigning or confirming to the holder of that office rank and precedence equal to that of Lord High Chancellor. From 1558 to 1700 there were eleven lord chancellors and twenty-one lord keepers; from 1700 to 1757, six chancellors and four keepers. The last lord keeper, appointed in 1757, was Lord Henley.

Keewatin is little more than a geographical expression for a part of the country lying north of the province of Manitoba. Its extent has been considerably curtailed of late years by the delimitation of the western and northern boundaries of Ontario and the eastern boundary of Manitoba, and its area is now computed at 282,000 sq. m. On the south the district is bounded by Manitoba from its north-east corner to the western shore of Lake Winnipeg. The western boundary is along the west shore of the lake to near Norway House, whence it goes in a northerly direction to the 53th degree of latitude, at the point where it intersects the Nelson River, and then passes west to the 100th degree of longitude, which it follows north to the limits of Canadian territory. On the east the boundary is a continuation of the eastern boundary of Manitoba until it reaches Hudson Bay, where it follows the coast-line to the northern limits of the Dominion. Keewatin is but little known. It is nominally administered by the lieutenant-governor of Manitoba, but is nearly uninhabited, excepting by Eskimos in the north. Norway House, an important station of the Hudson Bay Company, and one or two other posts belonging

to that corporation, are the only settlements in the districts. The principal attraction is the game, large and small, with which it abounds. In some parts valuable minerals are believed to exist, but they have not been developed. The country is well watered and timbered in many places, but is not suitable for cultivation to any extent. It embraces the northern part of Lake Winnipeg, with its important fisheries, and includes the mouth of the Saskatchewan River, which is navigable, except for a short distance, for nearly 1000 miles. The Nelson River passes through the province, as well as the Churchill and numerous smaller streams; and the Chesterfield Inlet on the western side of Hudson Bay penetrates nearly to its western boundary. The projected Hudson Bay Railway is planned to pass through Keewatin. See HUDSON BAY.

Kef, EL, a walled town of Tunis, 95 miles SW. of the capital, perched on the side of a steep hill, was noted in Carthaginian times for its temple to Astarte. There exist a ruined temple, therma, and cisterns of Roman construction. Pop. 4000, exclusive of a small French garrison. A picture of early Christian life at this place is given in Cardinal Newman's *Callista*.

Kehl. See STRASBURG.

Keighley (pronounced *Keethley*), a market and manufacturing town in the West Riding of Yorkshire, on the Aire, amid the moorland scenery of the Brontës' country, 9 miles NW. of Bradford and 17 WNW. of Leeds. It has a parish church (rebuilt 1848), a Gothic mechanics' institute (1870-87), the Drake trade school (1713; rebuilt 1860), extensive water-works (1876), and two public parks of 9 and 15 acres, gifted in 1887-88 by the Duke of Devonshire and Mr. J. Lund. The manufactures of worsted and woollen goods, worsted-spinning machinery, and sewing and washing machines are important. Keighley was constituted a municipal borough in 1882. Pop. (1851) 13,050; (1881) 25,245; (1891) 30,810. See R. Holmes, *Keighley, Past and Present* (1858).

Keightley, THOMAS, a busy writer, was born in Dublin in October 1789, and was educated at Trinity College there. In 1824 he settled in England to a life of letters, which he pursued assiduously till his death, November 4, 1872. His histories of Rome, Greece, and England held their place as school manuals until superseded by better books; of less moment were his notes to Virgil and Horace. But his *Fairy Mythology* (1850) largely retains its value, as also to a less extent does his *Life, Writings, and Opinions of Milton* (1855), and his annotated edition of Milton (1859).

Kei Islands. See KEY.

Keim, THILLOT, a distinguished theologian, was born at Stuttgart, 17th December 1825, studied under F. C. Baur at Tübingen; and was in turn *co-pastor* at Tübingen, vicar in Stuttgart, deacon and next archdeacon at Esslingen, and professor of Theology at Zurich (1860), and at Giessen (1873), where he died, 17th November 1878. He published valuable monographs connected with the religious history of Ulm, Esslingen, and Swabia; two volumes of sermons, entitled *Eraunderschaft zur Gemeinde* (1861-62); *Claus' wahres Wort* (1873); *Aus dem Ueberbretum* (1878); but the work by which his name will best be remembered is the noble contribution he added to the Lives of Christ. The preliminary studies, *Die menschliche Entwicklung Jesu Christi* (1861) and *Die geschichtliche Würde Jesu* (1864), were worked up into *Der geschichtliche Christus* (3d ed. 1866); but all three were preliminary to the great *Geschichte Jesu von Nazara* (3 vols. 1867-72; Eng. trans. 6 vols. 1873-83), a truly epoch-making work,

unequaled in learning, acuteness, and insight. Keim eliminates the miraculous element, but is in the highest degree reverent and spiritual in tone, regarding the person itself as the real miracle, the divinity of Jesus as depending on the elevation of his humanity attained through a sinlessness which of itself evidenced the miracle of God and his presence on earth. Keim's *Geschichte Jesu nach den Ergebnissen heutiger Wissenschaft* (1873) was a successful popular abridgment of his great work.

Kei River, GREAT, a river of South Africa, which in 1848 was made the boundary between Cape Colony and Kaffraria. Transkei is a magistracy of Kaffraria, comprising Fingoland, the Idutwya Reserve, and Gealekaland, and lying between the Great Kei River and the western boundary of Pondoland. The magistracy forms, administratively, a dependency of Cape Colony. Pop. 1020 Europeans and 152,550 natives.

Keith, ADMIRAL LORD. George Keith Elphinstone, Viscount Keith, was the son of the tenth Lord Elphinstone, and was named after his granduncle the tenth Earl Marischal Keith. Born at Elphinstone Tower, near Stirling, 7th January 1746, he entered the navy, saw service in most parts of the world, and distinguished himself in numerous engagements in the American war and the French wars. He commanded the expedition in 1795-97 which took Cape Town, and was made Baron Keith; and having had the command of the fleet which landed Abercromby's army in Aboukir Bay (1801) he was in 1814 made viscount. He died 10th March 1823. There is a *Life* by Allardyce (1882).

Keith, JAMES, best known as Marshal Keith, was born at the castle of Inverurie, near Peterhead, 11th June 1696. He came of a family, represented now by the Earl of Kintore, which from the 12th century had held the hereditary office of Great Marischal of Scotland, and whose principal seat was Dunnottar Castle (q.v.). Sir William Keith, the tenth in descent from the founder of the line, was created Earl Marischal in 1458; and George, fifth earl, his sixth descendant, in 1593 founded the Marischal College in Aberdeen. His fourth descendant, William, ninth earl (d. 1712), married Lady Maria Drummond, a Catholic and strong Jacobite, daughter of the fourth Earl of Perth, and by her was the father of Marshal Keith and of his elder brother, George, tenth Earl Marischal (1693-1778). James was destined for the law, and had studied at Aberdeen and Edinburgh, when in 1715 he engaged with his brother in the Jacobite rising, and in 1719 in Alberoni's expedition to the West Highlands, which ended in the 'battle' of Glenshiel (q.v.). Both times the brothers escaped to the Continent; and James held for nine years a Spanish colonelcy, and took part in the siege of Gibraltar (1726-27). But his creed, the Episcopal, was against him; and in 1728 he entered the Russian service as a major general. He distinguished himself in the wars with Turkey and Sweden, particularly at the siege of Ochakoff (1737) and the reduction of the Aland Islands (1743). To be healed of a wound received on the former occasion he visited Paris, and thence crossed over to London, where he made his peace with the Hanoverian government, and had more than one interview with George II. In 1747, finding the Russian service in various respects disagreeable, he exchanged it for that of Prussia. Frederick the Great knew his merits, and gave him at once the rank of field-marshal. From this time his name is associated with that of the king of Prussia, who relied as much on Keith's military genius as he did on the diplomatic ability of his brother, the Earl Marischal, whom he despatched on embassies to Paris and Madrid. Keith's talents became still

more conspicuous upon the breaking out of the Seven Years' War (1756). He shared Frederick's doubtful fortunes before Prague, was present at the victories of Lobositz and Rossbach, and conducted the masterly retreat from Olmütz. His last battle was not far distant. On 14th October 1758 at Hochkirch (q.v.) Keith, who commanded the Prussian right wing, was shot dead while for the third time charging the enemy. The Austrians buried him honourably in the church at Hochkirch, whence Frederick next year translated his remains to the Garrison church at Berlin. There, too, in the Wilhelmsplatz, Frederick in 1786 erected a statue of the marshal, a replica of which in bronze was gifted by King William to Peterhead in 1868. Keith died poor and unmarried, but he left children by his mistress, the Swedish captive, Eva Merthens, who survived him till 1811.

See his fragmentary but valuable *Memoir, 1717-34* (Spalding Club, 1843); the *Memoir of Marshal Keith, with a Sketch of the Keith Family* (Peterhead, 1869); Carlyle's *Frederick*; and the German Lives of Keith, by Vambagen von Ense (1844; new ed. 1888) and Lient. von Paczynski-Tenczyn (1889).

Keith-Falconer. See FALCONER.

Kekulé, FRIEDRICH AUGUST (1829-96), chemist, born at Darmstadt, and enrolled as Von Stradowitz in 1865, became professor at Ghent and at Bonn (1865). He made important researches in the chemistry of the organic substances, and published a famous handbook of organic chemistry (1861-67).

Kelāt (also spelt Khelat and Kalat), the capital of Beluchistan, stands at an elevation of more than 7000 feet, in 28° 52' N. lat. and 66° 33' E. long., and contains about 14,000 inhabitants. Seated on the summit of a hill, Kelat is a place of great military importance. It was occupied by England (1839-41); and in 1877 a treaty was concluded with the khan, by which a British agent, with military escort, became resident at Kelat. In 1893 the Indian government deposed the khan for misgovernment, his son being proclaimed khan in his stead. See BELUCHISTAN.—**KELAT-I-GHIZAI** is a fortress of Afghanistan, 75 miles NE. of Kandahar.

Kelati Nadiri, one of the strongest natural fortresses in the world, in the Persian province of Khorassan, and close to the Russian frontier of Transcaucasia. It was raised by Nadir Shah as a defence against the Turkomans upon an elevated valley in the Hezar Masjid Mountain, and shut out from external communication by lofty hills with precipices of 300 to 600 feet. Owing to Russia's schemes upon Khorassan, Kelati Nadiri has recently gained considerable importance.

Kellaways Rock, the name given to highly fossiliferous beds of sand and calcareous sandstones which occur near the base of the Oxford clay. See JURASSIC SYSTEM.

Keller, GOTTFRIED, German poet and novelist, was born at Glattfelden, near Zurich, on 19th July 1819. He studied at first landscape-painting at Vienna (1840-42), but shortly afterwards abandoned painting for literature. From 1861 to 1876 he was state secretary of his native canton. The works on which Keller's fame rests are the romance, *Der grüne Heinrich* (1854; new and revised ed. 1879-80); *Die Leute von Seldwyla* (1856), a collection of short tales, of which some, as *Romeo und Juliet auf dem Dorf*, *Kleider machen Leute*, and *Der Schmied seines Glucks*, are excellently told; the humorous *schöne Legenden* (1872); *Zürcher Novellen* (1878); a volume of *Gesammelte Gedichte* (1883); and the romance *Martin Sabander* (1886). Keller has a warm and fertile imagination, a rich humour, and true poetic feeling; he excels in the delineation of Swiss character. A collected edition

of his works appeared in 1889-90. He died 15th July 1890. See Life by Brahm (1883).

Kellermann, FRANÇOIS CHRISTOPHE, Duke of Valmy, born 28th May 1735, at Wolfsbuchweiler, in Alsace, entered a French regiment of hussars at seventeen, and had risen to the rank of major-general before the Revolution broke out. In 1792 he received the command of the Army of the Centre on the Moselle, repelled the Duke of Brunswick, and by his daring promptitude delivered France by the famous cannonade of Valmy. Yet on allegation of treason against the republic, he was imprisoned for a year, and only liberated on Robespierre's fall. He afterwards rendered important services in Italy, and on the erection of the Empire he was made a marshal and a duke. In the campaigns of 1809 and 1812 he commanded the reserves on the Rhine. At the Restoration he attached himself to the Bourbons. He was moderate and constitutional in his views. He died 12th September 1820. It was his son (1770-1835) whose charge turned Marengo (q.v.) into a victory.

Kells (originally *Keolis*), an ancient town of County Meath, Leinster, Ireland, situated on the Blackwater, 26 miles by rail W. of Drogheda. It has several interesting antiquities, including St Columba's house, a round tower, and three or four stone crosses. Kells was made the centre of a bishop's see in 807; this was united to the see of Meath in the 13th century. Previous to the Union Kells returned two members to parliament. Pop. 2822. A manuscript copy of the gospels, called the Book of Kells, is beautifully executed with coloured Celtic ornamentation, and is believed to be the work of the 9th century. It is now preserved in the library of Trinity College, Dublin. See ILLUMINATION OF MANUSCRIPTS.

Kelp (Fr. *carrech*) is the crude alkaline matter produced by the combustion of seaweeds, of which the most valued for this purpose are *Fucus vesiculosus*, *F. nodosus*, *F. serratus*, *Laminaria digitata*, *L. bulbosa*, *Hennanthalia litoria*, and *Chorda filum*. These are dried in the sun, and then burned in shallow excavations at a low heat. About 20 or 24 tons of seaweed yield one ton of kelp. The kelp met with in commerce consists of hard, dark-gray or bluish masses, which have an acrid, caustic taste, and are composed of chloride of sodium, of carbonate of soda, sulphates of soda and potash, chloride of potassium, iodide of potassium or sodium, insoluble salts, and colouring matter. It used to be the great source of soda (the crude carbonate); but, as this salt can now be obtained at a lower price and of a better quality from the decomposition of sea-salt, it is prepared in far less quantity than formerly from kelp. A ton of good kelp will yield about 8 lb. of iodine, large quantities of chloride of potassium, and additionally, by destructive distillation, a large quantity of volatile oil, from 4 to 15 gallons of paraffin oil, 3 or 4 gallons of naphtha, and from 1½ to 4 cwt. of sulphate of ammonia.

Till 1825, before the remission of the duty on salt and on Spanish bailla, the kelp manufacture (introduced into Tyree in 1746) was carried on to a very large extent in the north and west of Scotland, and the value of many estates in the Highlands and Hebrides greatly increased in consequence. About the beginning of the 19th century some 20,000 tons, worth from £200,000 to £300,000, were made annually on the western coasts of Scotland alone. Now the total annual produce in the United Kingdom will hardly exceed 7000 tons, at about £4 a ton. The greater part comes from Ireland, the remainder from the West Highlands and the Channel Islands. The French supplies do

not exceed those of Britain. See SODA, IODINE, SEAWEEDS.

Kelpie. See DEMONOLOGY.

Kelsey Beds, a subdivision of the Pleistocene accumulations, consisting chiefly of gravel, charged with marine shells and remains of mammoth, rhinoceros, &c., which occurs at Kelsey Hill near Heslon, and other places in the neighbourhood of Hull. The gravel rests upon and is covered by boulder-clay, and was probably deposited in the sea, near the mouth of a river.

Kelso, a pleasant market town of Roxburghshire, 23 miles by rail WSW. of Berwick-on-Tweed and 52 (by road 42) SE. of Edinburgh. It stands on the north bank of the Tweed, here joined by the Teviot, and spanned by Rennie's noble five-arch bridge (1803), 165 yards long. In 1126 David I. translated to 'Calehon' a Tironensian abbey, founded by him at Selkirk seven years before. This, wrecked by the English under Hertford in 1545, is now represented by the stately ruin of its cruciform church, Romanesque and First Pointed in style, with a massive central tower 91 feet high. Across the river, on the peninsula formed by the Teviot, stood the royal castle and town of Roxburgh, demolished in 1460; and 1 mile W. is Floors Castle (1718-1849), the seat of the Duke of Roxburgh. Kelso itself has a town-hall (1816), corn exchange (1856), high school (1878), race-course, coach-building and other industries, and memories of the '15, Scott, the Ballantynes, and Sir William Fairbairn. Pop. (1851) 4783; (1881) 4687; (1891) 4175. See works by Haig (1825), Cosmo Innes (1846), and Rutherford (1880).

Kelt. See SALMON.

Kelts. See CELTS.

Kelvin. LOCH. See THOMSON (WILLIAM).

Kemble, JOHN MITCHELL, Anglo-Saxon-scholar, was the son of Charles Kemble, the actor, and was born in London in 1807. He had his education partly under Dr Richardson, author of the *English Dictionary*, and partly at Bury St Edmunds grammar-school, whence in 1826 he passed to Trinity College, Cambridge, graduating B.A. in 1830. While an undergraduate he spent some time at Göttingen, under the brothers Grimm, who seem to have finally determined his natural bent towards Teutonic studies. The first fruit of these was an edition of the poem of Beowulf (1833-37), to a second edition of which he added a translation, with a glossary and notes. Not to mention several minor publications, he edited for the English Historical Society a valuable collection of charters of the Anglo-Saxon period, entitled *Codex Diplomaticus Ævi Saxonici* (6 vols. 1839-48). But his most important work, which contains the chief results of all his researches, is his unfinished *History of the Saxons in England* (2 vols. 1849; new ed. by W. de G. Birch, 1876). Further work was interrupted by sudden death at Dublin, March 26, 1857. Kemble was for a good many years editor of the *British and Foreign Review*; and also held the office of Licensor of Plays.

Kemble, JOHN PHILIP, eldest son of Roger Kemble, a well-known country manager, was born at Prescott, in Lancashire, on 1st February 1757. His father intended him for the Roman Catholic priesthood, and with this view he was sent to a seminary at Sedgeley Park, in Staffordshire, and afterwards to the English college at Douay. But the stage mania was on him, and he became, despite his father's earnest prohibition, an actor. His first professional appearance was made at Wolverhampton on 8th January 1776; he afterwards joined the famous York circuit, under the command of Tate Wilkinson; and he played also

in Ireland. The success of his great sister, Mrs Siddons (q.v.), gave him the eagerly-coveted chance of a London appearance, and on 30th September 1783 he played Hamlet at Drury Lane. His reading of the character was original and striking, and, though his acting was not then what it afterwards became, it aroused the keenest interest. He continued to play leading tragic characters at Drury Lane for many years, until, indeed, the shiftlessness of Sheridan forced him to leave the theatre. In 1788 Sheridan appointed Kemble manager, and his control of the theatre was notable for the care and completeness with which Shakespeare and the legitimate drama were produced. When driven from Drury Lane in 1802 he purchased a share (one-sixth) in Covent Garden Theatre, for which he paid £23,000. He became manager of that theatre, and made his first appearance there on 24th September 1803 as Hamlet. On 20th September 1808 the theatre was burned to the ground, and on the opening of the new building (18th September 1809) the notorious O. P. (i.e. 'Old Price') Riots broke out, in which the Kemble family were the special objects of public execration. Kemble retired in 1817. He took a formal farewell of the Edinburgh public on 29th March of that year, speaking a farewell epilogue written by his warm friend, Sir Walter Scott. His London farewell was taken on 23d June in his great character of Coriolanus. He afterwards settled down at Lausanne, where he died of apoplexy on 26th February 1823. As an actor Kemble probably has had no superior in the dignified, stately characters of tragedy—he was 'the noblest Roman of them all'—and his Coriolanus, his Brutus, and his Cato were perfect impersonations. He was a magnificently handsome man; stately, if rather stiff, in bearing; a thoroughly intelligent and educated speaker, though labouring under the disadvantage of a weak voice; and, above all, a man of remarkable intellectual power. He was also emphatically a gentleman.—STEPHEN, brother of the foregoing, was born in Herefordshire, 3d May 1758. As an actor he was chiefly remarkable for his enormous bulk, which enabled him to play Falstaff without stuffing. He was for some eight years (1792-1800) manager of the Edinburgh theatre, where he was in continual hot water through lawsuits and other troubles. He died in 1822.—CHARLES, younger brother of John and Stephen, was born at Brecon on 27th November 1775. In 1792 he made his first appearance on the stage at Sheffield as Orlando in *As You Like It*, and on 21st April 1794 made his debut in London, playing Malcolm to John Kemble's Macbeth. He continued on the stage till 1849, when, being appointed Examiner of Plays, he retired from the active exercise of his profession. He died on 12th November 1854. As an actor Kemble chiefly excelled in characters of the second rank, and his Laertes, Cassio, and Macduff were scarcely less interesting than his greater brother's Hamlet, Othello, and Macbeth. In comedy he specially distinguished himself, and his name is even yet a tradition for grace, delicacy, and joyous brightness. No man could play gentlemen more perfectly than Charles Kemble. Two of Charles's daughters complete the list of the Kembles. FRANCIS ANNE (Fanny Kemble), born in London, 27th November 1809, made her debut in 1829, when her tragic acting created a great sensation. In 1832 she went with her father to America, where two years later she married Pierce Butler, a Southern planter. They were divorced in 1848; and, resuming her maiden name, she gave Shakespearian readings for twenty years. She published dramas, poems, autobiography, &c., and died in London, 15th January 1893. ADELAIDE (1814-79) was distinguished as an opera singer, but retired before her marriage

with F. Sartoris. She was author of *A Week in a French Country House* (1867) and *Melba and Other Tales* (1868). See Percy Fitzgerald, *The Kembles* (2 vols. 1874).

Kemp, GEORGE MEIKLE, architect, was born at Moorfoot, in Peeblesshire, 26th May 1795, and up to the age of fourteen assisted his father, who was a shepherd. Becoming a carpenter and millwright, he afterwards sought work in England and France, everywhere settling in towns where he could study fresh specimens of Gothic architecture; but his intention of making a tour of Europe was checked by news of his mother's death, and he returned to Scotland in 1826. There he ultimately became a draughtsman in Edinburgh, and executed drawings of Scottish cathedrals for a projected Glasgow publication. This was abandoned, however, as was also a project to complete Glasgow cathedral, for which Kemp had prepared a model; but in 1838 his second design for the Scott Monument at Edinburgh was accepted. It is on this work alone that Kemp's fame rests, for before the completion of his fairy-like structure the architect was drowned in the canal at Edinburgh, on the night of 6th March 1844. See Life by T. Bonnar (1892).

Kempen, a town of Rhenish Prussia, 7 miles N.W. of Krefeld. It manufactures silk goods, wax candles, vinegar, &c. Pop. 5952. There is another Kempen in the Prussian government of Posen, 48 miles by rail N.E. of Breslau. Pop. 5787.

Kempis, THOMAS A. was so called from Kempen, where he was born in 1379. His family name was Hamerken (Latinised, *Malleolus*, 'Little-hammer'). He was educated at Deventer, and in 1400 entered the Augustinian convent of Agnetenberg near Zwole, of which his brother John was prior. Here he took the vows in 1406. He entered into priest's orders in 1413, and was chosen sub-prior in 1429, to which office he was re-elected in 1418. His whole life appears to have been spent in the seclusion of this convent, where he lived to an extreme old age. His death took place in 1471, at which time he certainly had attained his ninetieth, and most probably his ninety-second year. The character of Kempis for sanctity and ascetic learning stood very high among his contemporaries, but his historical reputation rests almost entirely on his writings, which consist of sermons, ascetical treatises, pious biographies, letters, and hymns. Of these, however, the only one which deserves special notice is the celebrated ascetical treatise *On the Following (or Imitation) of Christ*, the authorship of which is popularly ascribed to him. In its pages, says Dean Milman, 'is gathered and concentrated all that is elevating, passionate, profoundly pious in all the older mystics. No book, after the Holy Scripture, has been so often reprinted, none translated into so many languages, ancient and modern, extending even to Greek and Hebrew, or so often retranslated. At least eighty editions were printed between 1470 and 1500; and the total number of editions enumerated by Fr. Aug. de Backer (*Essai Bibliog.*, Liège, 1864) was about 3000. Before his death in 1873 he had collected evidence of more than 3000 additional editions. The earliest English translation, by Dr Atkinson, canon of Windsor, was printed by Pynson in 1503. It is strange that the authorship of a book so popular, and of a date comparatively so recent, should still be the subject of one of the most curious controversies in literary history. The book, up to the beginning of the 17th century, had been ascribed either to Thomas a Kempis or to the celebrated John Gerson (q.v.), chancellor of the university of Paris, except in one MS., which, by a palpable anachronism, attributes it to St Bernard; but from that time another claimant has

been put forward, Gersen, the so-called abbot of Vercelli, whose very existence has not been satisfactorily proved. His claim was strongly argued by Cajetan and many Benedictine writers, and later by M. de Grégory (*Memoire sur le véritable Auteur de l'Imit.*, 1830) and Renan, but the arguments against it of Father Eusebins Amout and Mgr. Malou (*Recherches histor.*, Tonnay, 3d ed. 1858) remain unanswered. These three competitors have divided the voices of the learned, not alone individuals, but public bodies, universities, religious orders, the Congregation of the Index, the parliament of Paris, and even the French Academy; and the assertors of their respective claims have carried into the controversy no small amount of polemical acrimony. Hilton, an English monk, has also been proposed as author; but the learned have now generally come to concede the honour to Kempis. The theology of the *Imitation* is almost purely ascetical, and (excepting the 4th book, which regards the eucharist, and is based on the doctrine of the real presence) the work has been used indiscriminately by Christians of all denominations. The most ancient perfect MS., written by Thomas's own hand, is in the Bourgogne Library at Brussels, and bears the date 1441, but we know that this was not the protograph MS., and indeed two MS. copies exist of 1425. We may therefore date the completion of the work between 1415 and 1424. An exact fac-simile was published at London in 1879, with an introduction by Charles Ruelens. Dr Carl Hirsche of Hamburg discovered that in this its original form the work was characterised by rhythmic periods, cadenced sentences, and frequent rhymes—a device not uncommon among mystical writers. He found also upon the MS. marks of a peculiar system of punctuation, employed not merely to mark the sense, but also to indicate these rhythms to a reader; and in 1874 he printed at Berlin an edition of the text in which these were set forth for the first time by a rearrangement of the matter in the paragraphs. The present division of the chapters into paragraphs was originally made by the Jesuit H. Sommalins (1599); the further division into verses was the work of the 17th-century editors. A new English translation, 'now for the first time set forth in Rhythmic Sentences according to the Original Intention of the Author,' was published in London in 1889, with a preface by Canon Liddon.

See Kettlewell, *Authorship of the De Imitatione* (1877) and his *Thomas a Kempis and the Brothers of the Common Life* (1882); Victor Becker, *L'Auteur de l'Imitation* (1883); Hirsche, *Prolegomena zu der Imitatio Christi* (1873: 94); L. Wheatley, *The Story of the Imitatio Christi* (1891). The translation, with introduction, &c., by Dr Bigg (1897), is based, like all English translations, on that of Anthony Hoskins the Jesuit (1568-1615), itself a modernisation of the older one by Richard Whytford (ed. 1520). See the bibliography in Wolfgruber's *Gersen* (1880).

Kempton, a town of Bavaria, 51 miles S. by E. of Ulm. The upper town grew up around a monastery (8th century) founded by disciples of St Gall; the abbot became a prince of the empire (1360), and the place a free town of the empire (1289). There are some manufactures. Pop. (1875) 12,682; (1895) 17,353.

Kempton Park, in Middlesex, 4 miles W. of Kingston-on-Thames, once a royal residence, is now noted for its race-meetings. See HORSERACING.

Ken, THOMAS, an English bishop of saintly memory, was born at Little Berkhamstead, Herts, in July 1637. His step-sister Anne Ken, twenty-seven years his senior, was the second wife of Isaac Walton. He had his education at Winchester, and at Hart Hall and New College, Oxford, obtained a fellowship in the last named in 1657,

and proceeded B.A. in 1661 and M.A. in 1664. He took orders at twenty-five, and held in succession the country livings of Little Easton in Essex, Brixton in the Isle of Wight, and East Woodhay in Hants. Already he had been elected a Fellow of Winchester College, and he now became also chaplain to the bishop, Dr George Morley. Here it was that he prepared his *Manual of Prayers for the use of the Scholars of Winchester College* (1674), and wrote his famous morning, evening, and midnight hymns, the first two of which, 'Awake, my soul, and with the sun,' and 'Glory to Thee, my God, this night,' are perhaps more widely known than any other English hymns. In 1674 Ken visited Rome, and five years later was appointed by Charles II. chaplain to the Princess Mary, wife of William of Orange, but offended William by insisting that a relative's promise of marriage should be kept, and returned home in 1680, when he was appointed one of the chaplains of the king. It was in March 1683, on the king's visit to Winchester, that Ken refused to give up his house for the accommodation of Nell Gwynne. Later in the same year he sailed to Tangiers as chaplain to Lord Dartmouth, and seven months after his return (in April 1684) was appointed Bishop of Bath and Wells. It is said that as soon as the king heard of the vacancy he remembered Ken's fearless honesty at Winchester, and asked, 'Where is the little man who wouldn't give poor Nelly a lodging? Give it to him.' He was consecrated in January 1685, and one of his first duties was to attend the death-bed of Charles. The chief public event of his bishopric was his trial and acquittal among the 'Seven Bishops' in 1688, for refusing to read the *Declaration of Indulgence*. At the Revolution he found himself unable in conscience to take the oath to William, having already sworn allegiance to King James, and was therefore superseded in his bishopric by Dr Kidder in 1691. He spent the remainder of his days in quiet retirement at Lord Weymouth's seat of Longleat, refusing to perpetuate the schism by consecrating non-juring bishops. On account of his growing weakness he declined to resume the duties of his diocese on Kidder's death in 1703, and gladly recognised his successor, ceasing to sign himself 'Bath and Wells' from that time. He died at Longleat, 19th March 1711, and was buried at sunrise of the 21st, beneath the chancel window in the churchyard of Frome Selwood.

Bishop Ken was esteemed a great preacher in his day, but his name survives now only from his hymns, and from his saintly personal character and the intensity of his devotion. And his morning and evening hymns deserve the world-wide reputation they enjoy, from the transparent simplicity, fervour, and truth with which throughout they are informed. His *Exposition on the Church Catechism* (1685) is his most important work in prose.

Ken's poetical works were collected by his great-nephew and executor, W. Hawkins, in four volumes in 1721; his prose works by J. T. Round in one volume in 1838. Hawkins published a selection from the works, with a Life, in 1713. A convenient collection of the prose works is that by the Rev. W. Benham in 1889 for the 'Ancient and Modern Library of Theological Literature.' There are Lives by the Rev. W. L. Bowles (2 vols. 1830-31), by 'A Layman'—Mr Anderson—(1851), Dean Plumpton (2 vols. 1888), and F. A. Clarke (1896).

Kendal, or **KIRBY KENDAL**, a market-town of Westmorland, on the Kent, 22 miles by rail N. of Lancaster and 13 SW. of Ambleside. It is a gray straggling place, with an ancient Gothic church, a ruined castle (the birthplace of Catharine Parr), a town-hall (1828), and a grammar-school (rebuilt in 1887). Flemings settled here in 1337, and the town became famous for its woollens and 'Kendal-green' buckram; whilst Pooecke in 1751

refers to its 'manufacture of a sort of frieze call'd cotton, at 8d. a yard, sold mostly for the West Indies, for the slaves.' Nowadays the industries include heavy textile fabrics, such as horse-cloths and railway rags, besides leather, snuff, paper, &c. Incorporated as a municipal borough in 1875. Kendal returned one member to parliament from 1832 till 1885. Pop. (1851) 11,829; (1891) 14,430. See two works by C. Nicholson (1832-75).

Kenia, **MOUNT**, an isolated mountain mass in eastern Africa, about 10' south of the equator, and not far north of Kilima-Njaro, nearly in the centre of British East Africa. It is also known as Doenyo Ebor, or White Mountain, because its summit is covered with perpetual snow. The crater wall rises up to a height of 16,000 feet, but the loftiest pinnacle towers up 3000 feet higher. Count Teleki partly ascended it in 1887, and Dr Gregory got to the bottom 17,000 feet in 1893.

Kenilworth, a market-town of Warwickshire, on a small sub-adjunct of the Avon, 5 miles N. of Warwick and 5 SSW. of Coventry. The castle, founded about 1120 by Geoffrey de Clinton, was defended for six months (1265-66) by Simon de Montfort's son, and passed by marriage (1359) to John of Gaunt, and so to his son, Henry IV. It continued a crown possession till in 1563 Elizabeth conferred it on Leicester, who here in July 1575 entertained her for eighteen days at a daily cost of £1000—that sumptuous entertainment described in Scott's *Kenilworth*. Dismantled by the Roundheads, the castle has belonged since the Restoration to the Earls of Clarendon. Its noble ruins comprise 'Cesar's Tower,' the original Norman keep, with walls 16 feet thick; Mervyn's Tower and the Great Hall, both built by John of Gaunt; and the more recent but more dilapidated Leicester's Buildings. There is a fragment also of an Augustinian priory (*c.* 1122); and the parish church has a good Norman doorway. Tanning is the chief industry. Pop. (1851) 2886; (1891) 4173.

Kennebec, a river of Maine, rises in Moosehead Lake, in the west of the state, and, passing Augusta, runs generally south to the Atlantic Ocean. Its length is over 150 miles. It is navigable for large vessels to Bath, 12 miles, and for steamers beyond Augusta. In its course it falls 1000 feet, affording abundant water-power. Except for a few miles from its mouth, the river is closed by ice for from three to four months in the year; and many companies are engaged in harvesting and storing the ice.

Kennedy, **BENJAMIN HALL**, one of the greatest of modern schoolmasters, was born in 1804, son of the Rev. Rann Kennedy, second master of King Edward's School, Birmingham, and had his education there and at Shrewsbury under Dr Butler, whence he passed to St John's College, Cambridge. His course was unusually distinguished: he carried off the Porson prize thrice, the medal for the Latin ode twice, and for the Greek ode once, and graduated in 1827 as senior classic, senior Chancellor's medalist, and senior optime. Next year he became Fellow and classical lecturer of his college, in 1830 an assistant master at Harrow, and in 1836 was appointed to succeed his old master, Dr Butler, at Shrewsbury. Here for thirty years he laboured with assiduous vigour and conspicuous success, forming for almost a generation a series of brilliant scholars, of whom need only here be named the greatest, H. A. J. Munro, the editor of Lucretius. The famous *Sobrietas Corolla* (1850; 4th ed. 1890) is an imperishable memorial at once of his own brilliant scholarship and of the spirit he could inspire. There never was perhaps a more dexterous and clever versifier in both Greek and Latin. In 1867 Dr Kennedy was appointed professor of

Greek at Cambridge and Canon of Ely. He died at Torquay, April 6, 1889.

Among his books were *Palæstra Latina* (1850); *Curriculum Stili Latini* (1858); the *Public School Latin Grammar* (1871); an admirable school edition of Virgil, annotated (1876); and editions, with verse translations, of the *Birds of Aristophanes* (1874), the *Agamemnon* of Æschylus (1878), and the *Oedipus Tyrannus* of Sophocles (1882). In *Between Whites* (1877) are collected many excellent poetical pieces in Greek, Latin, and English. Other works were *Occasional Sermons* (1877), *Plato's Theætetus*, with translation (1881), and *Ely Lectures on the Revised Translation of the New Testament* (1882).

Kenneth Macalpin. See SCOTLAND.

Kennicott, BENJAMIN, an eminent 18th-century biblical scholar, was born at Totnes, in Devonshire, April 4, 1718, son of the parish clerk and master of a charity school, to which latter office he succeeded at an early age. Some rich friends who recognised his promise helped him to enter Wadham College, Oxford, in 1744, and there he soon distinguished himself by his acquirements in Hebrew and theology, publishing, while still an undergraduate, two striking dissertations, *On the Tree of Life in Paradise* and *On the Oblations of Cain and Abel*. Soon after he was elected Fellow of Exeter College. In 1767 he was appointed Radcliffe librarian, and in 1770 canon of Christ Church, Oxford, where he died, August 18, 1783. The great work by which Kennicott's name will be remembered is his *Vetus Testamentum Hebraicum cum Variis Lectionibus* (2 vols. folio, 1776-80). Already in 1753 and further in 1759 he had published a work entitled *The State of the Printed Hebrew Text of the Old Testament considered*. This contained, among other things, observations on 70 Hebrew MSS., with an extract of mistakes and various readings, and strongly enforced the necessity for a much more extensive collation, in order to ascertain or approximate towards a correct Hebrew text. He undertook to execute the work thus projected in the course of ten years, and laboured, until his health broke down, from ten to fourteen hours a day. In spite of considerable opposition from Bishops Warburton, Horne, and other divines, Kennicott succeeded in enlisting the sympathies and obtaining the support of the clergy generally. Subscriptions to the amount of £10,000 poured in, and many foreign scholars, as Bruns of Helmstadt, undertook to help forward the work by collating MSS. in the libraries abroad. For ten years subsequently to 1760 accounts of the progress of the work were issued, and from first to last no fewer than 615 Hebrew MSS. and 16 MSS. of the Samaritan Pentateuch were collated. The text finally printed was that of Van der Hooght (without vowel-points), with the various readings printed at the bottom of the page. The *Variæ Lectiones Veteris Testamenti* (Parma, 1784-88), published by De Rossi, is a valuable addition to Kennicott's Hebrew Bible. Jahn published at Vienna (1806) a very correct abridgment, embracing the most important of Kennicott's readings.

Kemington, a district of Lambeth parish, and a division of Lambeth parliamentary borough, London. Kemington Oval, a little to the south of Vauxhall Bridge, is a famous cricket ground.

Kenosis. See CHRISTOLOGY, JESUS.

Kensal Green, a cemetery on the north-west of London, 77 acres in extent, was consecrated in November 1832; here many of the illustrious sons of England have been buried, as Thackeray, Leigh Hunt, Sydney Smith, Buckle, Sir Charles Eastlake, John Leech, Sir John Ross, Brunel, Mulhenny, Kemble, Dr Dibdin, Tom Hood, Balfe, Liston, Charles Matthews, Madame Vestris, Tietjens, Wilkie Collins, the Duke of Sussex, and his sister the Princess Sophia.

Kensington, a straggling parish in the west of London adjoining Westminster, within which, although noticed here, are Kensington Palace and Gardens. The former, given to the nation in 1899, and built of red brick, was the seat of Heneage Finch, Earl of Nottingham and Lord Chancellor, from whose successor William III. bought it in 1689; he and his wife Mary, Queen Anne and her consort Prince George of Denmark, and George II. all died within its walls, and it was also the birthplace of Queen Victoria. Kensington Gardens, which at first only consisted of the grounds of 26 acres attached to the palace, have been frequently enlarged, and are now 2½ miles in circuit; they are connected with the northern part of Hyde Park by a stone bridge over the Serpentine built by Rennie in 1826. At their southern extremity is the Albert Memorial (1872), designed by Sir Gilbert Scott, and consisting of a bronze gilt statue (by Foley) of the prince seated, placed beneath a gorgons canopy 180 feet high, and surrounded by works of sculpture illustrating the various arts and sciences. Opposite, in Kensington Gore, is the Albert Hall (1867-71), a huge circular building in the modern Italian style, of red brick with yellow dressings, used as a concert-room and capable of holding 10,000 persons; its cost was £200,000, and the interior measures 200 feet by 180 feet and is 140 feet high. Other buildings in the vicinity are the South Kensington Museum, Natural History Museum (see BRITISH MUSEUM), Royal School of Art Needlework, Royal College of Music (1883), City and Guilds of London Institute for the advancement of technical education (1884), and Imperial Institute, the opening of which by Queen Victoria took place in 1893. The parish church of St Mary Abbots—so called from the Abbots of Abingdon, to whom in 1107 a large part of the manor of Kensington was granted—is a fine building in the Gothic style, designed by Sir Gilbert Scott (1869), with a spire 295 feet high. Close by is the town-hall (1880) and the Roman Catholic Pro-cathedral (1869). Next to Kensington Palace, the most interesting building from a historical point of view is Holland House, a quaint mansion in the Elizabethan style, erected (1607) by Sir Walter Cope, and the great resort of the Whig politicians at the commencement of the 19th century. Amongst its occupants have been Fairfax, the Parliamentary general; Addison, who died in it; Shippen, the famous Jacobite; William Penn, the founder of Pennsylvania; and Charles James Fox, the statesman. Campden House, rebuilt in 1862 on its destruction by fire, is noteworthy from the former house, erected in 1612, having been the residence before her accession, of Queen Anne. Of the residences occupied by Swift, Sir Isaac Newton, Jack Wilkes, Wilberforce, George Canning and his son, Dr Dibdin, Sir David Wilkie, William Cobbett, Mrs Inchbald, Count D'Orsay, Talleyrand, Lord Macaulay, Thackeray, and John Leech but few traces now remain. The borough returns two members to parliament. Population of the entire civil parish, which includes Brompton, (1871) 120,299; (1891) 166,308. See Leigh Hunt's *An Old Court Sabuch* (1855), Loftie's *Picturesque Kensington* (1888), and Marie Liechtenstein's *Holland House* (1873).

SOUTH KENSINGTON MUSEUM was at first a temporary edifice of iron and wood (popularly known as 'the Brompton Boilers') which was erected by government (Science and Art Department) on part of the estate purchased out of the surplus funds of the Exhibition of 1851. It was opened in 1857, and to it were removed various collections which had since 1852 been exhibited in Marlborough House. This edifice has been superseded by permanent buildings still incomplete. The institution comprises (1) the Art Museum, (2) the India Museum,

(3) various science collections. The National Art Training School, the Normal School of Science, and the offices of the Department of Science and Art also form parts of the same group of buildings. The art collections comprise original works of decorative art of all periods and countries; paintings, chiefly of the English school, but including the cartoons of Raphael, the property of the crown; and reproductions in plaster, metal, &c. of sculpture, architectural decoration, and silversmiths' work. These have been acquired by purchase, gift, and loan. The cost to the nation has been about £400,000, while the value of the gifts and bequests is estimated at one million sterling. The India Museum, originally belonging to the East India Company, was handed over to the department in 1879. The science collections include machinery, naval models, &c., and apparatus for scientific teaching and research. The museum also contains art and science libraries. The visitors average 850,000 yearly. Monday, Tuesday, and Saturday are free days; on the other three days admission is sixpence. A system of circulation of examples on loan to provincial museums, science and art schools and classes, forms an important part of the operations of the museum. Numerous catalogues, handbooks on art subjects, and other publications have been issued. The original iron building was removed in 1865 and re-erected as the branch museum at Bethnal Green. The contents of this are chiefly loans, and are changed from time to time.

The gradual development of the Science and Art Department of the Committee of Council on Education has been sketched at *Attr.* Vol. I. p. 457. The department grants aid in connection with a system of annual examinations, in which prizes and Queen's medals are awarded; payments to teachers on the results of examinations and, to a limited extent, on attendance; scholarships and exhibitions; grants for buildings and apparatus; and aid to teachers while attending the Normal School of Science and the Royal School of Mines, South Kensington. The science examinations, for which an annual Directory is published, fall under twenty-five heads; and the science division of the department, which in 1872 had under supervision only 948 schools and 36,783 pupils, passed under review, in 1889, 2026 schools, giving instruction to 98,900 pupils in 6856 classes.

Kent, a maritime county in the SE. of England, is bounded by the Thames estuary, the Strait of Dover, Sussex and the English Channel, Surrey, and the county of London, whose creation in 1888 has reduced the area of the administrative county from 995,344 acres to 971,849 acres. Greatest length, 64 miles; breadth, 38 miles. The surface is for the most part hilly, except in the south-east, where lies a marshy tract, some 14 miles long by 8 broad, and in the north, where a line of marshes skirts the banks of the Thames and Medway; these last are backed by a succession of wooded hills, stretching inland and gradually increasing in height until they culminate in the North Downs (see *Downs*), a chalk range which traverses the middle of the county from west to east, attaining at Knockholt Beeches, near Sevenoaks, a height of 782 feet above the sea-level. Below these downs lies the Weald of Kent, a district abounding in beautiful scenery, and occupying nearly the whole southern side of the county. Of rivers in Kent, besides that which forms its northern boundary, the principal are the Medway, Stour, and Darent. The climate is in general mild and healthy, and the soil, which consists principally of chalk, gravel, and clay, is fertile, particularly in the south-east, where the rich meadows of the Romney Marsh afford excellent pasturage for vast flocks of sheep. All branches of agriculture are extensively carried on, especially

market-gardening and the growth of Hops (q.v.) and fruit of various kinds. In 1889 the extent of land under cultivation as hop-gardens was 35,487 acres, or a hop-field almost five times larger than that of any other hop-growing county in England, and orchards and market-gardens covered 27,495 acres. Of other industries the principal are the manufacture of paper, bricks, and gunpowder. In 1890 coal of good quality was found in a heading adjoining the Channel Tunnel (q.v.) at a depth of 1180 feet. Large numbers of hands are employed in the government establishments at the Woolwich arsenal and the dockyards of Chatham and Sheerness; whilst at Ashford are the locomotive and carriage works of the South-Eastern Railway, and at Whitstable and Faversham are important oyster-fisheries. Kent is divided into five lathes, and comprises 73 hundreds, the Cinque Ports (q.v.) of Dover, Hythe, Romney, and Sandwich, the cities of Canterbury and Rochester, and 18 municipal boroughs—in all 435 civil parishes, almost wholly in the dioceses of Canterbury and Rochester. Pop. (1801) 397,624; (1841) 549,353; (1881) 977,706; (1891) 1,142,324 (in administrative county, 785,674). The county includes eight parliamentary divisions, and the parliamentary boroughs of Canterbury, Chatham, Dover, Gravesend, Greenwich, Hythe, Lewisham, Maidstone, Rochester, and Woolwich, with part of the borough of Deptford, each returning one member. The county council numbers 96. The chief towns, in addition to those mentioned above, are Ramsgate, Margate, Folkestone, and Tunbridge Wells, all popular watering-places. A peculiarity in the tenure of land in Kent is that of Gavelkind (q.v.).

In historical associations the county is unusually rich. The earlier incidents down to the Heptarchy are noticed at *ENGLAND*, Vol. III. pp. 348-49; subsequent to the successive occupations of the Danes and Normans, during which the county was the scene of many a battle, the principal events in its history are—the murder of Archbishop Becket at Canterbury (1170); the submission of King John to the Pope's Legate at Dover (1215); the invasions by Louis, Dauphin of France (1216); the insurrections of Wat Tyler (1381), Jack Cade (1450), and Sir Thomas Wyatt (1554); the encampment at Blackheath of the Cornish insurgents under Lord Audley (1497); the rising of royalists at Maidstone (1648), and its subsequent suppression by Fairfax; and the destruction of shipping in the Medway by the Dutch fleet under De Ruyster (1667). Dover was the scene of the death of King Stephen, and Faversham of his burial; at Greenwich Henry VIII. and Queen Mary and Elizabeth were born, and Edward VI. died; Eltham Palace (now in ruins) was for a long time a royal residence; at Sayes Court, Deptford, which occupied a portion of the site of the royal victualling yard, lived Peter the Great whilst learning the trade of a shipwright; and at Chislehurst Napoleon III. died. Of its early inhabitants Kent has numerous traces in the shape of Roman roads, and many camps and barrows; at Aylesford and Hartlip Roman villas and baths have been discovered, and near the former place is a curious dolmen known as Kits Coty House. Of edifices of a historical or antiquarian interest it will suffice to specify here the cathedrals of Canterbury and Rochester, the Norman fortress of the latter place, with those of Chatham and Dover, and the moated mansions of Hever (the home of Anne Boleyn), Ightham Mote (dating back to the 14th century), and Leeds Castle (where Richard II. and Joan of Navarre were imprisoned). Amongst Kentish worthies are included Caxton the printer, Elizabeth Barton the 'nun of Kent,' Sir Nicholas Bacon, Sir Francis Walsingham, Camden the antiquary, Sir Philip Sidney, Harvey the discoverer

of the circulation of blood, the 'judicious' Hooker, the Earl of Chatham and his son William Pitt, General Wolfe, Richard Barham, author of the *Ingoldsby Legends*, the historians Hallam and Grote, Charles Dickens, Gordon Pasha, and Cameron the African explorer.

See the county histories of Hasted (4 vols. 1778-99; new and enlarged ed. 1886, &c.) and Dunkin (3 vols. 1856-58); also T. Frost's *In Kent with Charles Dickens* (1880); Abell's *History of Kent for the Young* (1895); and Bosworth's *Kent, Past and Present* (1900).

Kent, DIKE OF (1767-1820), fourth son of George III., and father of Victoria (q.v.).

Kent, JAMES, an American jurist, was born in New York state, 31st July 1763, graduated at Yale in 1781, and was admitted to the bar in 1787. After serving two terms in the legislature he was professor of Law in Columbia College from 1794 to 1798, when he was appointed a justice of the supreme court of New York; and in 1804 he became chief-justice, and in 1814 chancellor of the state. In 1823 he retired from the bench, but he continued his chamber practice for many years after. Kent's principal publication was his famous *Commentaries on American Law* (4 vols. New York, 1826-30; 14th ed. 1894), a monumental work, which has not yet been superseded in the United States. He died 12th December 1847.

Kentigern, St, the apostle of Cumbria, was son of the Princess Thenew, who, being found to be with child, was first cast from Dimpender or Traprain Law, and next exposed on the Firth of Forth in a coracle. It carried her out to the Isle of May and then back to Culross, where she bore a son (about the year 518). Mother and child were brought by Shepherds to St Serf, who baptised them both, and reared the boy in his monastery, where he was so beloved that his baptismal name Kentigern ('chief lord') was often exchanged for Mungo ('dear friend'). Arrived at manhood, he planted a monastery at Cathures (now Glasgow), whither he had been led by two untamed bulls; and in 543 he was consecrated Bishop of Cumbria. In 553 the accession of a tyrannous prince drove him to seek refuge in Wales, where he visited St David, and where, on the banks of another Clyde, he founded another monastery and a bishopric, which still bears the name of his disciple, St Asaph. In 573 he was recalled by a new king, Rederech Hael ('Roderick the Bountiful'); and first at Hoddam in Dumfriesshire, then at Glasgow, he renewed his missionary labours. About 584 he was cheered by a visit from Columba. He died 13th January 603 ('when he was 185 years old'), and was buried at the right-hand side of the high altar in Glasgow Cathedral. A fragment of a Life, composed at the desire of Herbert, Bishop of Glasgow, and the longer *Vita Kentigerni* by Joceline of Furness, both belong to the later half of the 12th century. Bishop Forbes gives translations of them, and we have adopted his rationalising chronology. Joceline's Life teems with miracles, which were rooted so deeply in the popular fancy, that some of them sprung up again in the 18th century to grace the legends of the Cameronian martyrs. Others are still commemorated by the annual hearings of the city of Glasgow—a frozen hazel branch which his breath kindled into flame, St Serf's pet robin which he restored to life, a hand-bell which he brought from Rome, and a salmon which rescued from the depths of the Clyde the lost ring of Rederech's frail queen. Nor is it St Mungo only whose memory survives at Glasgow; St Enoch's Church commemorates his mother, St Thenew. To the saint himself there are eight dedications in Cumberland, and fourteen in Scotland.

See Bishop Forbes's *Lives of SS. Ninian and Kentigern*

(1874); Skene's *Celtic Scotland* (vol. ii. 1877); and Beveridge's *Culross and Tulliallan* (1885).

Kentish Fire, a form of applause at public dinners or meetings of a political character, consisting in clapping the hands in unison in a peculiar rhythm or cadence, thus: *a a-*, intensified occasionally by the cry of 'rah' at certain intervals. The effect is very striking if the clapping is well led and kept together, and may be taken to bear some resemblance to the rattle of musketry fire. Hence the name. The origin is more obscure, but the 'volleys' were probably first organised at the great Kentish meetings in 1828-29 to protest against Roman Catholic emancipation. In 1834 at a great Protestant meeting in Dublin (August 15) Lord Winchelsea introduced 'his Kentish artillery' as a novel and stirring feature, and Kentish Fire has ever since been a favourite mode of applause at Protestant, Conservative, or 'Orange' meetings especially in the north of Ireland.

Kentish Rag is the local name given to a grayish blue and occasionally arenaceous and cherty limestone, which occurs at Hythe and other places on the coast of Kent, in the Lower Greensand Measures. It is sometimes 60 to 80 feet thick.

Kentish Town, a district in St Pancras parish, in the north of London.

Kent's Cavern, or KENT'S HOLE, is notable for the evidence which it has furnished as to the contemporaneity of man in Britain with various extinct or no longer indigenous mammals. It is situated in a small wooded limestone hill in the immediate neighbourhood of Torquay, and appears to have been known from time immemorial, although it did not attract the attention of scientific men until 1825. The early explorers of the cave, Northmore, Trevelyan, MacEnery, Godwin-Austen, and (in 1846) a committee of the Torquay Natural History Society, all succeeded in finding flint implements mixed up with the remains of extinct animals. But these discoveries received little attention until 1858, when the results of the systematic exploration of Brixham Cave by a committee of the Royal Society led to the appointment in 1864 of a similar committee by the British Association for the examination of the deposits in Kent's Cave. The results of this exploration, carried on under William Pengelley (1812-94), from March 1865 to June 1880, at a cost of £1963, are of the highest importance. They show that the bottom of the cave is paved with a succession of sheets of stalagmite, red earth, and breccia—all of which have yielded relics of man and various extinct or no longer indigenous mammals. Amongst the former are palæolithic flint tools and implements of bone, such as a needle with a well-formed eye, an awl, a harpoon, &c., also perforated badger's teeth, which were probably used for ornamental purposes. The animal remains comprise those of lion, bear, mammoth, machairodus latidens, rhinoceros, hyæna, reindeer, Irish elk, red deer, wolf, fox, badger, gibbon, beaver, &c. In one part of the cave there occurred underneath stalagmite a dark layer some 4 inches thick, which consisted mainly of small fragments of charred wood. This doubtless was an old hearth, round which the palæolithic cave-dwellers gathered to roast bones for the sake of their savoury marrow. The sheets of stalagmite are of inconstant thickness—the lower one attaining in places a thickness of 12 feet, while the upper one does not seem to have exceeded 5 feet, and was frequently very much thinner. The general character and structure of the cave-deposits show that a prolonged time was required for their accumulation. See M. W. Pengelley's address to the British Association (1883), and the Life of him by his daughter (1897).

Kentucky, a river of Kentucky, is formed by two forks which rise in the Cumberland Mountains, and, after a winding north-west course of about 250 miles, enters the Ohio, 12 miles above Madison, Indiana. The river runs through part of its course between perpendicular limestone walls. It is navigable by steamboats to beyond Frankfort.

Kentucky, a state of the American Union, in the great central or Mississippi Valley, lies between 36° 30' and 39° 6' N. lat. and between 82° 3' and 89° 30' W. long. Its greatest length from

east to west is about 400 miles; its breadth from north to south about 175 miles; its area is 40,400 sq. m. The eastern and south-eastern parts of the state are mountainous, broken by the Cumberland Mountains (2000-3000 feet) and their offshoots. Westward from this region is a plateau sloping gradually toward the Ohio and the Mississippi rivers, which bound the state on the north and west. Large cypress-swamps still exist in some parts, especially in the south-west. Kentucky has a river boundary of more than 800 miles in length, including a stretch of nearly 650 miles along the Ohio, 50 miles on the Mississippi, and 120 on the Big Sandy. The Cumberland, Tennessee, Licking, and Kentucky rivers rise among the mountains in the east, and cross the state to the Ohio, whose other large tributaries, the Green and the Trade-water, rise in the west. The considerable extent of water thus available for navigation has lately been increased by a system of river improvements. Besides these natural highways of commerce Kentucky has 2800 miles of railroad. Southward from the Ohio River extends a semicircular tract of land of Silurian formation; here the soil is produced by the disintegration of the fossiliferous blue limestone, and its fertility is unrivalled. This section is the famous Blue Grass (q.v.) country, in which the most exhausting crops, such as tobacco and hemp, may be raised continuously for a series of years without materially impairing the productive value of the soil, the constant crumbling of the fossiliferous shales restoring those constituents which have been withdrawn by the rich growth of vegetation. Surrounding the blue-grass country is a somewhat narrow belt of Devonian shale; its soil is also very fertile, and the lower strata contain petroleum. In the southern and south-eastern parts of the state there are other tracts of Devonian deposits, some of which yield heavy lubricating oils. The eastern, the western, and the southern portions of Kentucky belong mainly to the Carboniferous age, and the structure consists of sub-carboniferous limestone, or of true carboniferous deposits, with extensive coalfields. The coal-measures are the result of several alternate exposures and submersions, and average at least ten good beds of coal. Through the central part of the state is a strip of land which appears to have remained permanently raised above the sea during the Carboniferous period, and thus forms a divide between the eastern and the western coal-areas. The eastern coalfield is a prolongation of the Appalachian deposits, and is about 10,000 sq. m. in extent. The western belongs to the Illinois tract, and measures about 4000 sq. m. The coal is bituminous, and some excellent cannel occurs. Next in importance to coal are the iron ores, which are of excellent quality, and are found throughout a district of 20,000 sq. m. in extent. Neither the coal nor the iron deposits are worked as thoroughly as their quality and their abundance would seem to justify, but the output is increasing. Gadsen is found in some sections; valuable building-stones occur almost everywhere; and salt is obtained by boring in the coal and the oil regions.

Through the limestone formations the streams

have cut deep gorges, and within a region of about 6000 sq. m. in the sub-carboniferous structure, much of the drainage is subterranean. The surface topography is peculiar, as there are many round or oval-shaped 'sinks' through which the water reaches the underground streams. The long-continued erosive action of the water has undermined a large part of this region, and produced the numerous and often extensive caverns which form one of the remarkable physical features of this state. Of these the best known, though possibly not the largest, is the Mammoth Cave (q.v.).

Kentucky is densely wooded, except in those places that are under cultivation; at present about two-thirds of the state is covered with virgin forests. Among the prevailing species of trees are the blue ash, the black walnut, various kinds of oak, the pine, the maple, the tulip-tree, and the sweet gum. Notwithstanding this large proportion of forest land, Kentucky has always been one of the leading agricultural states, and its products are noted for their variety. It is the principal tobacco-producing state in the union. The state has always been a centre for rearing domestic animals, and for breeding the finest grades of stock. A very large percentage of the successful racehorses of the United States have been bred in Kentucky. The peculiar advantages for stock-raising are due in part to the excellent quality of the grass, and in part to the mild salubrious climate, which permits the cattle to remain unhoused in the pastures during the greater part of the winter. Kentucky's principal manufacture is whisky, which is made in large quantities in the central section. The smelting and working of iron are the only other manufacturing industries of any considerable importance.

Kentucky is divided into 117 counties, and contains 19 cities and over 300 towns and villages. The most important cities are Louisville, Covington, Newport, Lexington, and Frankfort, the capital. The governor and the 38 state senators serve for four years, the 100 representatives for two. Besides two senators, Kentucky sends eleven representatives to congress. The state is practically out of debt, and has a permanent school fund of \$1,799,447. The enrolment of pupils in the common schools exceeds 300,000. There are several important colleges and schools of higher education, some of them affiliated with the Kentucky University at Lexington. Pop. of the state (1860) 1,155,684; (1880) 1,648,690; (1890) 1,858,635.

History.—Numerous remains indicate that the mound-builders lived here in considerable numbers; but at the time of its first occupation by the whites this region seems to have been a hunting-ground visited by both the northern and the southern tribes of Indians, and not permanently occupied by settlements. The name Kentucky, signifying 'the dark and bloody ground,' is supposed to commemorate the conflicts between the various warlike tribes. One of the earliest pioneers was Daniel Boone (q.v.). This whole territory was included in the original grant to the colony of Virginia, and in 1776 received the name of Kentucky county. In 1790 it was made a separate territory of the United States, and in 1792 was admitted as a state. Kentucky did not secede during the civil war, and several campaigns were waged within its borders.

Keokuk, a city of Iowa, is situated almost at the south-east extremity of the state, on the Mississippi River (here crossed by a railroad bridge), 161 miles by rail ESE. of Des Moines. Keokuk has a large trade, nine lines of railway touching the town. The largest steamboats could always come up to Keokuk, and the 'Des Moines rapids,' immediately above, are now passed by a great canal, 11

miles long, which cost some 5 million dollars. The town contains law, medical, and commercial colleges, and has several foundries, saw and flour mills, and factories. Pop. (1890) 14,101.

Kepler, or **KEPLER**, **JOHANN**, one of the very greatest astronomers, was born at Weil der Stadt, a village in Wurtemberg, 10 miles from Stuttgart, 27th December 1571. He was left to his own resources when a mere child, his education depending on his admission into the convent of Maulbronn. He afterwards studied at the university of Tübingen, applying himself chiefly to mathematics and astronomy. In 1593 he was appointed professor of Mathematics at Gratz, and about 1596 commenced a correspondence with Tycho Brahe (q.v.), which resulted in his going to Prague in 1599 to aid Tycho in his work. Tycho obtained for him a government appointment, but the salary was not paid, and Kepler lived for eleven years there in great poverty. He then obtained a mathematical appointment at Linz, and fifteen years afterwards was removed to the university of Rostock, poverty still pursuing him. He died shortly afterwards at Ratibon, 15th November 1630.

In character he was intensely enthusiastic, imaginative, laborious, and persevering, all qualities fitting him for the great task of transforming astronomy from a merely formal into a true physical science. Though Copernicus (q.v.) had transferred the centre of the planets' movements to the sun, these were still considered as compounded of various circles, the only curve thought fit for celestial bodies to pursue. No cause was assigned for their movements, and no unity observed among them, except in the one fact of the sun being their centre. Kepler says, 'I brooded with the whole energy of my mind' on this subject, asking 'why they are not other than they are—the number, the size, and the motion of the orbits.' In fact he had first to determine what the orbits were before answering some of these questions. But one question lay open before him. The periods of the planets were fairly well known, so were their proportionate distances from the sun. Was there any invariable relation between these? In his *Mysterium*, published in 1596, he triumphantly proclaims that five kinds of regular polyhedral bodies govern the five planetary orbits. Yet after publication he still continued to 'brood,' becoming at length convinced that this theory was only an error, until after twenty-two years of patient study and numberless speculative failures, he was able at last to announce (in his *Harmonice Mundi*, 1619) that the 'square of a planet's periodic time is proportional to the cube of its mean distance from the sun.' This rule is known as Kepler's Third Law. He saw clearly enough that it implies that the planets are moved by a force greater near the sun, and lessening with distance, but he did not grasp, as Newton after him did, the truth that this is an attractive force constantly acting towards the sun, nor could he therefore guess the law of its action. Finding the theory of epicycles unable to bear the strain of Tycho Brahe's accurate observations, especially in the case of the planet Mars, he endeavoured to find a law for the planet's movements which would be simple and satisfactory. After enormous labour, and by a process of trial and error, he found that (1) *the planet's orbit was an ellipse, of which the sun is in one focus*, and (2) *that, as the planet describes its orbit, its radius vector traverses equal areas in equal times*. These rules (published in 1609 in his work on *The Motions of Mars*) are known as Kepler's First and Second Laws respectively. These laws formed the groundwork of Newton's discoveries, and are the starting-point of modern astronomy. Besides, we owe to Kepler many discoveries in optics, general physics,

and geometry. A collected edition of his works was published by Frisch (1858-71).

For further information, see Brewster's *Lives of Galileo, Tycho Brahe, and Kepler* (1841); Reithinger, Neumann, and Gruner, *Johannes Kepler* (1868); and Whewell's *Hist. of Inductive Sciences* (vol. i.).

Keppel, **AUGUSTUS**, **VISCOUNT**, English admiral, was the son of William, second Earl of Albemarle, and was born on 20 April 1725. Entering the navy, he served under Hawke in 1757, captured Goree in 1758, took part in the battle of Quiberon Bay in 1759, and in the capture of Belleisle in 1761, and commanded at the capture of Havana in 1762. In 1778 he encountered the French fleet off Ushant on 27th July; a sharp but indecisive action ensued; but owing to a disagreement between Keppel and Sir Hugh Palliser, his second in command, the French were suffered to escape without a renewal of the combat. Both admirals were brought before a court-martial, but both were acquitted. The affair made a great stir in the country, the popular verdict being on the side of Keppel. In 1782, in which year he was created Viscount Keppel of Elveden in Suffolk, he became First Lord of the Admiralty, but resigned on Pitt's accession to government. Keppel died, unmarried, on 3d October 1786. See Life by T. Keppel (1842).

Keppel, **SIR HENRY**, British admiral, a younger son of the fourth Earl of Albemarle, was born 14th June 1809. He saw service as captain during the war against China in 1842, and in the campaign against the pirates of the East Indian Archipelago shortly afterwards. During the Crimean war he commanded a vessel in the Baltic and Black Seas, and finally the operations of the naval brigade before Sebastopol. In 1857 he took an important part in the destruction of the Chinese fleet in Fatshan Bay. He was promoted to be vice-admiral in 1867, full admiral in 1869, a G.C.B. in 1871, and admiral of the fleet in 1877. Sir Henry Keppel has written *Expedition to Borneo with Rajah Brooke's Journal* (3d ed. 1847), *Visit to the Indian Archipelago* (1853), and *A Sailor's Life under Four Sovereigns* (1899).

Ker, **THE FAMILY OF**, supposed to be of Anglo-Norman extraction, is found in Scotland in the end of the 12th century. The present representatives derive their descent from John Ker of Altonburn in 1357, whose great grandson Andrew acquired Cessford about 1440, and gave origin in his three sons to the families of Cessford, Linton, and Gateshaw, and in a grandson to that of Fernihirst. Sir Andrew Ker of Cessford (died 1526), whose younger brother, George, was ancestor of the Kers of Fandonside, had two sons—Sir Walter, whose grandson, Robert, was created Earl of Roxburghe in 1616, and Mark, commendator of Newbattle, whose son, Mark, was created Earl of Lothian in 1606. The second Earl of Roxburghe was only a Ker by his mother. He assumed the surname of Ker, and his grandson, the fifth Earl of Roxburghe, was created duke in 1707. John, third Duke of Roxburghe (1740-1804), was the famous book-collector. Robert Carr, the favourite of James VI., created Viscount Rochester in 1611 and Earl of Somerset in 1613, belonged to the family of Fernihirst.

Ker, **JOHN**, D.D., Presbyterian minister and professor, was born in 1819 at the farmhouse of Bield, in Peeblesshire, and early in life removed with his parents to Edinburgh. He was educated at the High School and university, and was for a time under Tholuck at Halle. He was licensed as a preacher in 1844, and ordained at Abwick in 1845. He accepted a call as assistant to East Campbell Street Church, Glasgow, in 1851, where, in the course of a few years, his popularity and the demands made upon his services

broke his health. From 1863 onwards he travelled much, visiting America, and residing in Italy. He occupied the chair of Practical Training in the United Presbyterian Theological Hall from 1876 till his death, October 3, 1886, and his ability, culture, large heartedness, and quiet earnestness made a deep impression. His *Sermons* (1868, 14th ed. 1888; second series 1886, 3d ed. 1888), by their intellectual power, chastened eloquence, insight, and spiritual tone, carried his name far beyond the bounds of his own denomination. His other works, mostly posthumous, are *The Psalms in History and Biography* (1886); *Lectures on the History of Preaching* (1888); *Letters, 1864-85* (1890); *Thoughts for Heart and Life* (1888). See *Memorial Discourses on his Death* (1886).

Keratin. See HORN.

Kerbela, a town and holy place in Asiatic Turkey, 60 miles SW. of Bagdad. Pop. 60,000. The pilgrims number at least 200,000 annually; and a railway was projected by Midhat Pasha, when governor of the provinces, from Bagdad to Kerbela in 1869. The contractors, however, failed to carry out the works, though actually commenced. The sanctity of Kerbela arises from the fact that it is built on the site of the battlefield on which Hussein, son of Ali and Fatima, lost his life (689) in attempting to maintain his right of succession to the califate. Every Shi'ite Moslem throughout the world who can afford it seeks sepulture in the holy ground. The number of dead Moslems conveyed from Bombay alone is considerable. See Geary, *Asiatic Turkey* (1878).

Kerguelen's Land, or DESOLATION ISLAND, of volcanic origin, situated in the Antarctic Ocean, between 48° 39' and 49° 44' S. lat. and 68° 42' and 70° 35' E. long., being 85 miles long by 79 wide. The surface is mountainous (Mount Ross, 6120 feet), and most of the interior is covered with an ice-sheet and its glaciers. Numerous islands and rocks encircle the coasts. The shores are very irregular, long fjords penetrating far inland and forming good harbours. The climate is raw, and storms are nearly constant. The island was discovered in 1772 by a Breton sailor, Kerguelen-Trémarec, and was visited by Captain Cook (who christened it Desolation Island) in 1776, and in 1874 by the *Challenger*, and by English, American, and German expeditions to observe the transit of Venus. It was annexed by France in 1892.

Kerguelen's Land Cabbage (*Pringlea antiscorbutica*), the only known species of a very curious genus of plants of the natural order Crucifere, found only in Kerguelen's Land. It has a long, stout, perennial root-stock, and a *bolled* head of leaves very similar to those of the common garden cabbage. Captain Cook first discovered this plant, and directed attention to it. The root-stocks have the flavour of horse-radish. The dense white heart of the cluster of leaves tastes like mustard and cress, but is coarser. The whole foliage abounds in a very pungent pale yellow essential oil, which is confined in vessels that run parallel to the veins of the leaf. The Kerguelen's Land cabbage is used by voyagers, boiled either by itself, or with beef, pork, &c., chiefly on account of its antiscorbutic qualities.

Kerki, a town belonging formerly to Bokhara, central Asia, about 120 miles S. of Bokhara city, on the left bank of the Amu Daria or Oxus. An important place both commercially and strategically, it is the halting place of the caravans trading from Bokhara to Herat, and stands near the chief ferry over the Oxus. The fortress, consisting of a high mud wall, flanked by bastions, was in 1885

strengthened by Russia, who in May 1887 occupied it, and garrisoned it with regular troops.

Kermadec Islands, a group of volcanic islands in the Pacific Ocean, 700 miles NE. from Auckland in New Zealand. It consists of four principal islands—Raoul or Sunday (7200 acres), Macaulay (756 acres), Curtis, and L'Esperance, and several smaller islands. A Mr Bell settled in 1878 on the islands, which in 1887 were declared part of New Zealand. The climate resembles that of New Zealand. The group was discovered in 1788, and annexed by Great Britain in 1886. See S. Percy Smith's *Kermadec Islands* (1887).

Kerman, or KARMAN (anc. *Caramania*), one of the eastern provinces of Persia, lying south from Khorassan, and having an area of about 59,000 sq. m. The north and north-east are occupied by a frightful salt waste called the *Desert of Kerman*, which forms a part of the great central desert of Iran. On this extensive tract not a blade of grass is to be seen. The southern portion, although mountainous, is equally arid and barren with the north, except the small tract of Numanshir, towards the east, which is fertile and well watered. Roses are cultivated for the manufacture of otto of roses; silk and various gums are exported. The inhabitants, who number about 300,000, are chiefly Persians proper; the rest are Guebres or Parsees, Beluchis, and other wandering tribes.

Kerman, the chief town, is situated near the middle of the province, in the central mountain-range, and contains a population estimated at 30,000. The trade, though still considerable, is very small compared with what it was during the 18th century, when Kerman was the great emporium for the trade by the Persian Gulf and the Indian Ocean. In 1722 the town was destroyed by the Afghans; in 1791 it was taken and pillaged by Aga Mohammed, and 30,000 of the inhabitants made slaves. But the chief cause of the decline of its trade was the fall of Gombroon (q.v.), its port, before the rising prosperity of Bushire. At present Kerman is only noted for the manufacture of the famous Kerman carpets (a sort of woollen rugs), felts, and brass cups.

Kermanshah (also KARMANSHAH and KIRMANSHAHAN), a flourishing town of Persia, capital of Persian Kurdistan, near the right bank of the river Kerkhah. It is the centre of converging routes from Bagdad, Teheran, and Ispahan. Its commerce is considerable, and there are manufactures of carpets and weapons. A railway has been projected from Bagdad, the intervening country presenting no engineering difficulties. But between Kermanshah and Teheran the country is mountainous. Pop. 30,000.

Kermes, a dyestuff obtained from an insect (see DYEING). The name is also given to a cherry-red mineral, usually in tufts of capillary crystals; a mixture of sesquioxide and sesquisulphide of antimony; approximate composition (Sb²S₃)₂.Sb₂O₃. It was formerly much used for the same purposes as James's Powder (q.v.).

Kerner, ANDREAS JUSTINI'S, one of the leading members of the 'Swabian School' of poets, was born at Ludwigsburg, in Wurttemberg, 18th September 1786. He studied at Maulbronn, and afterwards medicine at Tübingen, and settled in 1818 as a physician at Willbad, and finally at Weinsberg. Here he died, 21st February 1862. Along with his friends Uhland and G. Schwab he published *Der poetische Almanach* (1812) and *Der deutsche Dichtersaal* (1813). But his chief poetical works are *Reiseballaden aus dem Schattenspiegel der* (1811); *Romantische Dichtungen* (1817); and *Der alte Blutstocuss* (1852). His poetry approaches closely to the *Folkslieder* in freshness and simple

city, and is lit up with gleams of humour: but it sometimes drops to the lower levels of romanticism. He took a keen interest in the phenomena of animal magnetism, and wrote several books on the subject, one of which, *Die Schwinen von Prevorst* (1829; 6th ed. 1892), excited great attention. See Lives by Niehammer (1877) and Reinhard (1886), and Du Prof's *De Schwinen von Prevorst* (1886).

Kerosene (Gr. *kēros*, 'wax'), one of many names under which petroleum, paraffin, or shale oils are sold in different countries for burning in lamps. The name originated in America, and is still much used there in reference to petroleum for domestic use. It is the name also by which generally these mineral oils are known in India, China, and the colonies, and under which they are imported in tins and cases from America, Russia, or Great Britain.

Keronalle, LOUISE DE. See CHARLES H.

Kerowlie. See KARAWL.

Kerry, a maritime county in the south-west of Ireland, in the province of Munster, is bounded on the N. by the estuary of the Shannon, and on the W. by the Atlantic Ocean. Area, 1,185,918 statute acres, or 1853 sq. m. There are under crops about 170,000 acres, and of these 93,000 are laid down as permanent pasture, some 30,000 are planted with potatoes, and 25,000 sown with oats. One-fourth of the area is barren mountain land, and more than 11 per cent. bog and marsh. Maximum length, north to south, 67 miles; maximum width, 55 miles. Its coast-line is about 220 miles in length; is fringed with islands, of which the chief are Valentia (pop. 2920), the Blasquets, and the Skelligs; and is deeply indented by Kenmare, Dingle, and Tralee Bays. Between these and the smaller bays are extensions of the mountain-system which stretches westward from the county of Waterford. The principal group is Maegillieuddy's Reeks, the chief summit of which, Carran Tuail, 3414 feet, is the highest in Ireland. The rivers are short and of little consequence. The county contains numerous lakes, some of them, especially the Lakes of Killarney (q.v.), of exquisite beauty. The climate is mild, but moist, especially on the coast. The soil rests on slate and sandstone, with limestone. Iron, copper, and lead ores abound, but are not much worked. Slate and flagstone are quarried in Valentia. The manufactures are inconsiderable; oats and butter are the chief exports. The fisheries on the coast employ nearly 2000 men and boys. Since 1885 Kerry returns four members to the House of Commons. Pop. (1841) 293,880; (1871) 496,914; (1881) 201,639; (1891) 179,136, nearly all Roman Catholics. The county is rich in ancient ruins, including the remains of Muckross Abbey and Innisfallen.

Kersanton, the name given to several varieties of igneous rock which are rich in plagioclase felspar and dark mica, and contain carbonates. They occur in the form of dykes traversing the palaeozoic rocks of Brittany. The name is from Kerzanton, a small hamlet on the Brest Roads. Granular varieties of kersanton are called *kersantite*, while those which have a marked porphyritic structure are known as *mica-porphyrates*.

Kersey, or KERSEMYERE, a variety of woollen cloth, differing from ordinary broad cloth by being woven as a *twill* (see TWILL). It is easily distinguished from the common cloth by the diagonal ribbed appearance of its upper side, where the nap, not being raised, allows its structure to be seen. A very thin line make of Kersey is called *cassimere*.

Kertch, previous to being levelled with the ground by the allies in 1855 the most important

port of the Crimea, with a large trade in the export of corn, is situated on the eastern shore of the peninsula, on the strait of Kaffa or Yenikale, which, 26 miles long and 3 to 25 wide, connects the Sea of Azov with the Black Sea. The port still has a trade to the extent of nearly £200,000 annually in grain, linseed, leather, fish, and caviare (all exported). The museum for the Greek and other antiquities discovered in the neighbourhood was removed to the Hermitage at St Petersburg after having been partly filled by the allied soldiers in 1855 (cf. D. Macpherson, *Antiquities of Kertch*, 1857). Two and a half miles to the south of the town are the fortified works designed to protect the passage of the straits. Kertch, the ancient *Pantikapum* or *Bosporus*, founded in the middle of the 6th c. B.C. by Milesians, was the capital of the ancient kingdom of the Bosporus, and subsequently of a state founded by the son of Mithridates, about 100 B.C. From 1318 to 1475 it was a depot of the Genoese; then it came into the hands of the Turks; and finally, in 1771, it was acquired by the Russians. Pop. with the neighbouring Yenikale (1890) 30,900.

Kesteven, THE PARKS OF, the south-west division of Lincolnshire (q.v.).

Kestrel, or WINDHOVER (*Falco tinnunculus*), a small species of falcon found in the north of Europe in the warmer months, resident in the



Kestrels (*Falco tinnunculus*):
1, the male; 2, the female.

south all the year round, and particularly abundant in Spain. In Britain it is one of the commonest birds of prey, though its numbers were considerably reduced by persecution before its harmlessness and its utility as a check on the too rapid multiplication of mice were fully recognised. The name windhover refers to the bird's graceful habit of balancing itself in gale or calm, as some other birds do, by a slight, continuous flapping of the wings. Jeffries thus describes the mechanism of hovering: 'While hovering there are several forces balanced: first, the original impetus onwards; secondly, that of the depressed tail dragging and stopping that onward course; thirdly, that of the wings beating downwards; and fourthly, that of the wing a little reversed beating forwards, like backing water with a scull.' The food of the kestrel consists chiefly of mice, but it also eats insects, which it catches while on the wing, and occasionally small birds. It rarely builds a nest of its own, but appropriates one forsaken by another bird, or lays its eggs in any convenient cavity. The eggs are creamy

white, thickly mottled with reddish brown, or sometimes entirely reddish brown. The adult male measures about 13 inches; the prevailing colour is a pale brown marked with black; the head, neck, and tail are bluish gray. The female is larger than the male, and is reddish brown with bars of black. The Lesser Kestrel (*F. cenchris*), which has occasionally been found in Britain, closely resembles the common species, but has the claws white instead of yellow. The common sparrow-hawk of the United States (*F. sparverius*) is also a near relative, and allied species are found in nearly all parts of the world. The whole group is sometimes separated off from Falco as a sub-genus *Tinnunculus*.

Keswick, a market-town of Cumberland, near the confluence of the Greta and the Derwent, 16 miles NNW. of Ambleside, and by a branch-line (1865) 18 W. of Penrith junction, 36 SSW. of Carlisle. In its immediate vicinity are wooded Castle Head and beautiful Derwentwater (q.v.), whilst to the north towers Skiddaw (3058 feet). A great tourist centre, it is a pleasant little place, lighted with the electric light in 1890, and possessing half-a-dozen hotels, a good public library, a recreation ground, a town-hall (1813), lead-pencil manufactories, and a church (1839), besides the old parish church of Crosthwaite, $\frac{3}{4}$ mile north, with Southey's grave. Pop. (1851) 2618; (1891) 3760. See LAKE DISTRICT.

Keszthely, a market town of Hungary, on the western shore of Lake Balaton, 113 miles by rail SW. of Pesth. Pop. 5393.

Ket, ROBERT, a tanner of Wymondham, in Norfolk, who raised the standard of insurrection in that county in July 1549. The cause of the outbreak was a widespread dissatisfaction of the country people against the gentry. Sixteen thousand men gathered round Ket, who raised his mimic throne beneath the 'Oak of Reformation' on Monshold Hill, overlooking Norwich. This city was twice captured by the rebels; on the second occasion they held it until they were driven out by the Earl of Warwick, and compelled to fight a battle, in which Ket was defeated and captured. He was afterwards hanged at Norwich. The insurrection never had more than a local significance. See the Rev. E. W. Russell's *Ket's Rebellion* (1860).

Ketch, a broad, strongly built vessel of two masts, viz. the main and mizzen, formerly much used for carrying mortars, and called a bomb-ketch.

Ketch, JACK. See EXECUTION.

Ketchup, or CATSUP, is a name given to certain sauces much valued for flavouring soups, meats, fish, &c. It may be prepared from a variety of fruits and vegetables; but the ketchups in most ordinary use are those made from common mushrooms (*Agaricus campestris*), unripe walnuts, and ripe tomatoes. The fruit or vegetable is first broken or bruised with salt, and allowed to stand for about twenty-four hours to extract the juice; the juice must then be expressed, put into a pan, and boiled with appropriate seasonings until it is reduced to about half the quantity. It should be allowed to cool before it is bottled, and then, if tightly corked, will keep for years.

Ketones. See ACETONES.

Kettering, a market-town of Northamptonshire, 75 miles NNW. of London by rail. The parish church, dating from about 1450, and restored in 1862, is a fine Perpendicular structure, with tower and spire. A town hall and coin exchange was built in 1863; and Kettering has also a free grammar school, water-works (1872), and manufactures of boots and shoes, stags, brushes,

&c. The charter for the market was given by Henry III. in 1227 to the monks of Peterborough. Pop. of parish (1861) 5845; (1891) 19,454.

Kettledrum. See DRUM.

Keuper, the upper division of the Triassic System (q.v.).

Kew, a village in Surrey, 6 miles W. of Hyde Park Corner, and on the right bank of the Thames, which is here crossed by a fine granite bridge, rebuilt in 1899, and 55 feet wide. Foremost among objects of interest at Kew are the Royal Botanic Gardens and Arboretum, containing magnificent collections of plants and ferns, both native and exotic, and of trees and shrubs. Established in 1760 by the mother of George III., and made a national institution in 1840, the gardens now extend over 70 acres, and the arboretum 178 acres, and the annual cost of keeping them up amounts to about £20,000. In 1882 there were 1,244,167 visitors to the gardens, whilst on Whit-Monday 1890 it was computed that nearly 100,000 persons were admitted. In addition to numerous hot-houses and conservatories, the principal features are a palm-house 362 feet by 100 and 66 feet high; a temperate-house of the same height, occupying three-fourths of an acre; three museums; a laboratory; the North gallery, containing sketches from nature taken in different parts of the world; and the Pagoda, an octagonal ten-storied building 163 feet high. To the south-west of the gardens is an observatory, chiefly used as a meteorological station; here are kept the thermometer and other meteorological and magnetical instruments which serve as standards for the United Kingdom. Close to the northern entrance is Kew Palace, formerly a favourite residence of George III., and of Queen Charlotte, who died there. In the church, built in 1714, and subsequently enlarged, is an organ presented by George IV., and said to have been used by Handel. The late Duke and Duchess of Cambridge are buried in the vaults, and in the churchyard adjoining are the graves of Gainsborough, the painter, and two less-known artists, Meyer (George III.'s miniature-painter) and Zoffany. Sir Peter Lely once lived on the Green. Pop. (1801) 424; (1881) 1670; (1891) 2076.

Kewatin. See KEEWATIN.

Keweenaw Point, a peninsula of Michigan (q.v.), projecting into Lake Superior, and co extensive with Keweenaw county (350 sq. m.; pop. 4270). It is famed for its copper-mines.

Key, in Music, the series of notes, or scale, in which modern music is written. Each note on the staff may form the *tonic* or key-note of a scale, which is called after the name of that note (see MUSIC). A piece is said to be in such and such a key when that key predominates throughout; and the tonic harmony of the key is always to be found at the close of the piece, unless it leads to some further movement. It is held by many that each of the various keys has a character, or colour, as it is termed, of its own. In connection with music, the name key is also given to the levers by which the pianoforte, organ, &c. are played; to the levers on wind-instruments for opening or closing certain of the sound-holes; and to the west used for tuning the pianoforte, drum, &c.

Key, FRANCIS SCOTT, author of 'The Star-spangled Banner,' was born in Maryland, 9th August 1780, practised law at Frederick City and at Washington, and became district attorney for the District of Columbia. It was during the British invasion in 1814, at the attack on Baltimore, which he witnessed from an English man-of-war, that Key, after watching through the gray dawn to see which flag floated over the ramparts of Fort

Melhenry, wrote the words which have kept his name alive. He died 11th January 1843. A collection of his poems appeared in 1857. There is a handsome monument by Story, erected at the expense of James Lick, at San Francisco.

Key. THOMAS HEWITT (1799-1875), headmaster of University College School and professor of Comparative Grammar in University College, London, was eminent as a Latin philologist and author of a *Latin Grammar* and of a *Latin-English Dictionary* (new ed. 1888).

Key, or Kei, Islands, a small group in the East Indies, lying S. of Dutch New Guinea and N.E. of Timor, consists of Great Key, Little Key, and some smaller islets. Total area, 680 sq. m. Pop. about 20,000, Malays and Alfuros; three-fourths on Great Key. This is a long narrow island, stretching north to south, volcanic in origin, and with a rocky, hilly surface that rises to nearly 3000 feet. Little Key, situated to the west of Great Key, is of coral formation, and lies low; it is said to have made its appearance in the middle of the 19th century during an earthquake disturbance. All the islands are covered with dense jungle. Valuable timber is the chief product. Fishing is the chief occupation; and *beche de mer* is gathered. The group has been in the hands of the Dutch since 1645. See G. Laugen in *Pearl, Rom. Geog. Soc.* (1888), and *Seal. Geog. Mag.* (1888 and 1890). The islets of the Bahama group in North America are called generally keys or cays (Span., 'rocks' or 'reefs').

Keyne. St. a holy virgin said to have lived about 300, whose name survives in an old church in Cornwall near Liskeard, and still more so in its famous well. Whoever of a newly-married pair first drinks of its water will bear rule throughout their life together. All the world knows from Southey's ballad the story of the bride who outwitted her husband by taking a bottle to church. The well is mentioned by Fuller and Carew, but the reader will find fuller details in Cyrus Redding's *Illustrated Itinerary of Cornwall* (1842).

Keys, POWER OF THE. See POPE.

Key West, a port of entry and capital of Monroe county, Florida, is situated on the island of Key West (Span. *Cayo Hueso*, 'Bone Reef'), 60 miles SW. of Cape Sable. It is a coral island, 7 miles long, 2 to 3 wide, and nowhere more than 11 feet above the level of the sea. There is a good harbour, defended by a casemated brick fort; and the buildings include a custom-house, barracks, and a marine hospital. The exports are salt, turtle, sponges, fruits and vegetables, and cigars. Dangerous reefs make the business of salvage important. The warm and equable climate attracts consumptives. The place was a great military and naval centre during the war with Spain in 1898. Pop. (1870) 5016; (1880) 9800; (1890) 18,085.

Khabarovka, at the junction of the Ussuri with the Amur, is the capital of the Maritime Province (q.v.) of Siberia. Pop. 30,000.

Khairpur, the chief town of Khairpur state, in Sind, stands among marshes about 15 miles E. of the Indus. It was once a very important city. Pop. 7000. Area of state, 6100 sq. m.; pop. (1891) 131,937, mostly Mohammedans.

Khalid. See MOSAYLIMA, CALIF.

Khalif. See CALIF.

Khama, the reforming chief of the Bamangwato in the Bechuanaland (q.v.) Protectorate, was born in 1846, and on a visit to England in 1895 secured recognition for his stringent regulations for exclusion of alcohol and maintenance of order.

Khamsin, or KHAMASIN. See EGYPT.

Khan, a title of Mongolian or Tartar sovereigns and nobles. A *Khanda* is a principality. Khan is also a name for Caravanseraï (q.v.).

Khandeish, or CANDÉISH, a district on the northern edge of the Deccan, in Bombay Presidency, lies south of the Nerbudda and east of Baroda, and is intersected by the Tapti river. Area, 10,907 sq. m.; pop. 1,460,851.

Khamia. See CANEA.

Kharasim. See KHIVA.

Kharkoff, capital of the Russian government of Kharkoff, and one of the chief towns of the Ukraine, is by rail 312 miles NW. of Taganrog and 465 S. by W. of Moscow. It is the seat of a Greek bishop and of a university, with four faculties and about 900 students. Attached to the university (founded in 1805) are an observatory, a library of 56,000 volumes, a botanical garden, anatomical museum, &c. This university was a centre of the Nihilist movement. The chief industrial products are sugar, soap, candles, felt, brandy, tobacco, and iron; but the place is principally celebrated for its four great fairs, at two of which (in horses and wool) the mited turnover amounts annually to the sum of nearly £3,000,000. Pop. (1873) 87,000; (1895) 196,500.—The *government*, situated in Little Russia, has an area of 21,035 sq. m.; pop. (1893) 2,537,900, principally Little Russians and Cossacks. It forms a plateau of moderate elevation, scamed by the deep-cut river-courses of the affluents of the Don. Nearly one-half of the area is arable land.

Khartoum, or KHARTUM, once the most important town in the eastern Soudan, stands on the low tongue of land between the Blue and the White Nile, just above their junction, 445 miles SW. of Suakin (*via* Berber), and 1625 S. of Cairo, following the windings of the Nile. It was founded under the rule of Mehemet Ali (q.v.) in 1823, and soon became a place of commercial importance, and was made the capital of Egyptian Soudan. As starting-point and terminus of caravans to the interior, it was notorious for its great activity in the slave-trade. Ivory, ostrich feathers, gums, and tamarinds were other articles of commerce. It shared the evil fortune of the Soudan (q.v.); and General Gordon (q.v.) defended it against the forces of the Mahdi (q.v.) in 1884-85. Two days before the rescue army reached it Khartoum fell, and Gordon was amongst the slain (26th January 1885). Pop. then, about 60,000; a half being Turks, Greeks, Syrians, Arabs, and Egyptian craftsmen, the rest representing the varied races of Eastern Africa. But Khartoum was now deserted for Omdurman, just below and on the left bank of the river, which was the capital of the Mahdi and his successor, the Khalifa, till the advance of Kitchener's force in 1898. On 2d September the dervishes were routed and the Khalifa's power broken at Omdurman; and two days after, the British and Egyptian flags were hoisted on the ruined residency where Gordon fell. The population of Omdurman was believed to be 100,000. After the occupation the administration was restored to Khartoum; and in 1899 the Gordon Memorial College was founded at a cost of over £100,000, the design being to give the intelligent natives of the region a good education, without alarming their religious susceptibilities.

Khási, a series of hills or step-like plateaus in Assam, on the watershed between the Brahmaputra and the Surma, and with the connected Jaintia Hills giving name to a district. The rainfall is enormous, reaching in some parts in 1885-95 an annual average of over 500 inches. Lime, oranges, and potatoes are exported; coal and iron ore

exist, but only the latter is extracted. The language of the Khasis, an Indo-Chinese race, 'has no analogy elsewhere in the whole of India; it is described as 'monosyllabic in the agglutinative stage.' The principles of female descent and female authority are the most marked among their social customs. See Dalton's *Ethnology of Bengal* (1872).

Khatmandu, the capital of Nepal, stretches for about a mile north from the confluence of the Bagmati and Vishnumati rivers. It contains a great number of temples, many in pagoda shape, with roofs of brass, and others domed; but the houses are in general mean, their court yards filled with rubbish-heaps, and the streets are narrow and filthy in the extreme. The principal building is the immense ugly palace of the Maharaja; close to its modern *darbar*, or reception room, is the large military council chamber, the Köt, where in 1846 most of the chief men of the state were massacred. The population is about 50,000.

Khaya, a genus of trees of the natural order Urticaceæ. The Kasson-Khaye of Senegal (*K. senegalensis*), one of the most abundant forest-trees in that part of Africa, attains a height of eighty or one hundred feet, and is much valued for its timber, called *caïcedra*, or African mahogany, which is reddish coloured, very hard, durable, and of beautiful grain. In the marshy coast regions of Gambia the bark is administered in the cure of fever, and Caventon has extracted an alkaloid which has been suggested as a cheap substitute for *quinia*, a product of the bark of *Hortia braziliana*.

Khayyam. OMAR. See OMAR.

Khazars. See CHAZARS.

Khedive, a title granted in 1867 by the Sultan to his tributary the Viceroy of Egypt, and since then used by the latter as his official title. The word (pronounced as a dissyllable) is derived from Persian *khâdir*, and means 'sovereign.' It is therefore a more dignified title than *cali*, 'viceroy.'

Khelat. See KELAT.

Kherson, or CHERSON, capital of the Russian government of that name, stands on the Dnieper, 49 miles from its mouth and S. N. E. of Odessa. The town was laid out by Prince Potemkin in 1778 as a port for the construction of ships of war; but in a few years, owing to the unfavourable character of the river, it was supplanted by Odessa and Nikolaiëff, both as a dock-yard and a commercial outlet. It has a large trade in timber, and manufactures soap, tallow, beer, and tobacco. Wool-cleansing is an important industry. At Kherson Potemkin is buried, and John Howard, the prison reformer, died. Pop. (1871) 46,320; (1898) 67,811. The government borders on the Black Sea, having the Dnieper for its eastern boundary and the Dniester for its western, while the interior is watered by the Bug, Ingul, &c., which form shallow, salt lagoons next the sea. The soil towards the south is steppe-land; in the north, where it touches the 'black earth' region, it is more fertile. Area, 27,515 sq. m.; pop. (1897) 2,728,523. There are seventy German (Swabian) colonies, with about 50,000 inhabitants. Agriculture, gardening, and cattle-breeding are the chief occupations; and there are iron foundries, corn mills, machine-factories, tanneries, carriage-works, and brandy-distilleries. The government embraces several large towns, as Kherson, Odessa, Nikolaiëff, Otchakoff, Velisavetgrad, Voznesensk, and Tiraspol.

Khiva, also called KHARASM, KHWARIZM, or URGANDJ (anc. *Chorasnia*), a Khanate of Turkestan in central Asia, lies between 37° 45'–44° 30' N. lat. and 59° 15'–63° E. long., and contains

about 25,000 sq. m., the surface being mostly a sandy desert, with many fertile tracts scattered over it. It is bounded on the N. by the Russian territory and Sea of Aral, E. by the Khanate of Bokhara, S. by Persia, and W. by the Caspian Sea. The chief oasis, in which the capital Khiva is situated, stretches from the mouth of the Oxus or Amu Daria for 200 miles along its banks, and is watered by artificial canals supplied from that river, to which it entirely owes its fertility. The inhabited area is about 5000 sq. m. The population has been estimated to consist of 260,000 settled inhabitants and nearly as many nomads. Amongst them are Uzbeks, Karakalpaks, and Turkomans (all Ural-Altaië), Aryan Sarts and Tajiks, probably the original inhabitants of Khiva, and Kizilbash, mostly liberated Persian slaves.

Khiva in ancient times was nominally subject to the Seleucids; subsequently it formed a part of the kingdoms of Bactria, Parthia, Persia, and the Califate, and became an independent monarchy in 1092 under a lateral branch of the Seljuk dynasty. The Khivans, or, as they were then called, the Chorasmiens, after conquering the greatest part of Persia and north-western Afghanistan, were obliged to succumb to the Moguls, under Genghis Khan, in 1221. In 1370 Khiva came into the hands of Timür. Timür's descendants were supplanted in 1511 by Shady Beg (called Sheibani Mehemmed Khan by western writers), chief of the Uzbeks, a Turkish tribe, and his successors ruled over Khiva till the end of the 18th century, when they were supplanted by Kirghiz and Karakalpak princes, and from the beginning of the 19th century by the Kungrat branch of the Uzbeks. Ever since the Russians entered central Asia they have complained that the Khivans fostered rebellion among their Kirghiz subjects, and plundered their caravans. In 1717 Peter the Great endeavoured to conquer Khiva, but was defeated, and in 1839 the attempt was renewed by the Czar Nicholas, with no better success. War may be said to have recommenced when new Russian forts in 1869 and 1871 were founded on the shores of the Caspian. It was not, however, till 1873 that a great effort was made finally to crush Khiva. To diminish the difficulties of crossing the deserts the Russian force was divided into five columns, each about 3000 strong, to approach Khiva by different routes. After enduring with admirable fortitude great privations and fatigue, the Russians entered Khiva on the 10th of June. The Khan agreed to pay a war indemnity and to cede to Bokhara the Khivan possessions on the right bank of the Amu-Daria. Shortly afterwards, however, these possessions, including the seat of the Karakalpaks near the embouchures of the Oxus, were incorporated with Russian territory, and now Kizil-Kum and the annexed part of Khiva form the Russian government of Amu Daria, with an area of 39,820 sq. m., and an estimated pop. of 109,600. The rest of Khiva is ruled by the Khan, under Russian suzerainty. KHIVA, the capital of the Khanate, is on the Hazreti Pehlivan Canal, in the western portion of the great oasis. It consists almost entirely of earth-huts, not excepting the residence of the Khan, the only brick buildings being three mosques, a school, and a caravansarai. Pop. 20,000. Other towns are Yengli Urgent, the commercial centre of the Khanate, and Kungrat, not far from the Aral. See works by Vambery (1864), Burnaby (1876), Stumm (Eng. trans. 1885), and Lansdell (1885).

Khoi, a town in the Persian province of Azei-bijan, on the highway between Tazeroum and Tabriz, which lies 75 miles to the S. E. Here Selim I. defeated the Persians in a great battle in 1514. The surrounding district, which is a fertile plateau,

yields grain, fruit (especially mulberries), and cotton. Pop. 25,000.

Khoikhoi. See *HOTENTOTS*.

Khojend, a walled town of Russian Turkestan, on the Sir-Daria, 75 miles S. by W. of Khokand, and 150 E. by N. of Samarcand. It stands in the midst of gardens, and manufactures silk. At one time independent, it was alternately in the hands of the emirs of Bokhara and Khokand until the Russians seized it in 1865. Pop. 35,000.

Khokand, once a khanate of Turkestan, extending east of 64 long, over the whole of the upper basin of the Jaxartes or Sir-Daria. But long previous to the commercial treaty between Russia and Khokand, in 1868, the khanate had been confined to an area of some 30,000 sq. m. In 1875 a rebellion against the khan, who was already practically a Russian vassal, led to Russian intervention. After a fierce struggle the immediate result was the annexation to Russia of all the territory of Khokand lying north of the Sir-Daria. Now the whole khanate forms the Russian government of Fergiana (q.v.), a name under which Khokand was famous throughout the East during the middle ages. The town of Khokand has 54,000 inhabitants.

Khonsar, or KHUNSAR, a town of Persia, in the province of Irak-Ajemi, 80 miles NW. of Isfahan, and on the route from that city to Hamadan. Pop. 12,000.

Khorassan, the largest province of Persia, bordering on Afghanistan, contains about 210,000 sq. m., of which nearly one-third is a vast salt waste; of the remainder a large portion consists of plains of shifting sand. The fertile districts are in the north, where the high range of the Elburz crosses the province, throwing out spurs, and forming a mountainous district, abounding with fertile and well-watered valleys. Artificial fertilisation by means of canals was here carried on to a great extent in ancient times, but the incessant disturbances which have unsettled the district for the last thousand years have almost put an end to this system. The chief products are grain, cotton, silk, hemp, tobacco, aromatic and medicinal plants, fruits, wine, salt, gold, silver, and precious stones, especially turquoises, also camels, horses, and asses. The chief towns are Meshed, the capital, Ni-shapur, Kutehan, Shahrud, Khaf, Kain, and Tebbes.

Khorassan means in ancient Persian *eastwards*, and is said to have extended over all central Asia in the north, to the Helmund on the S., to the Panir on the E., and to the Caspian on the W. After the conquest of the Arabs the country beyond the Oxus became a possession of the Samanide dynasty, whilst Khwarizm (the modern Khiva) was taken by the Seljuks. Herat and the adjoining districts remained in the possession of the Timurides, though sometimes retaken by the Persians, until finally it fell under the sway of the Afghans. Khorassan, being situated on the highway of the Turko-Tartar invasions into the west of Asia, had always to bear the brunt of predatory hosts coming from beyond the Oxus, and its chief towns repeatedly suffered destruction. Recently the invasion has come from the west; and the northern slopes of the Kubbet Mountains, together with the oasis of Merv, including the middle course of the Heri-rud, have been annexed by Russia. See MacGregor's *Narrative of a Journey through Khorassan* (1879); and for the 'Veiled Prophet of Khorassan,' see *MOKANNA*.

Khorsabad. See *NINIVALE*.

Khosru. See *CHOSROES*.

Khotan, called locally *Uchi*, a city and district of eastern Turkestan, lying at the northern base of the Kuen-Lun Mountains, and only six miles from the desert. The district is rich in gold and jade, manufactures silk, and exports silk stuff, carpets, and jade ware. Pop. of city, 40,000.

Khurja, a town of British India, lying 50 miles S. of Meerut and 50 SE. of Delhi, is the chief commercial centre in the district of Bulandshahr. There is a large export of raw cotton to Cawnpore and Calcutta. Pop. (1891) 26,349, chiefly Pathans and Banyas. The latter have banking establishments all over India. They are Jains in religion, and own a fine modern temple.

Khuzistan (anc. *Susiana*), a province of Persia, having Fars and the Persian Gulf on the south, is divided into two almost equal portions, the one, the north-east, very hilly, the other, the south-west, so level as to be almost a stagnant sea in the rainy season, and an arid waste in summer. Khuzistan contains extensive pastoral districts, on which vast herds of cattle are reared, and abounds in soil fitted for rice, maize, cotton, sugar-cane, indigo. Under the rule of the califs Khuzistan was one of the richest provinces of the empire, and Ahwaz, the capital, acquired world-wide reputation for its sugar, carpets, and silk manufactures. With the downfall of the califate of Bagdad Khuzistan ceased to be a rich province; the highway of commerce on the Karun was shut up, and has been only recently reopened. See *KARUN*.

Khyber Pass, the great northern military road between the Punjab and Afghanistan, winds in a north-westerly direction for 33 miles between the projecting spurs of two enclosing ranges of hills. The pass is merely the bed of a narrow watercourse, and varies in width from 150 yards to 20, though in one place it is only '10 feet or less.' It is liable at times to be suddenly flooded. The mountains on either side are in many places perpendicular walls of smooth rock, and can be climbed only in a few places; they vary in height from 1104 to 3373 feet. Over the roughest parts of the pass artillery has to be dragged by men. The Khyber Pass has been the key of the adjacent regions in either direction from the days of Alexander the Great. During the Afghan wars of 1839-42 it was twice traversed by a British army, in spite of an obstinate defence by the natives. The first fighting in the Afghan war of 1878-80 was in forcing an entrance into this pass. It was stipulated in the treaty of Gandamak (1879) that the Anglo-Indian authorities were in future to have full control of this pass.

Kiachta, or *KIACHTA*, a town of the Russian province of Transbaikalia in Siberia, stands on a tributary of the Selenga, 165 miles SE. from Irkutsk, and close to the Chinese frontier, being only separated by a piece of neutral ground, 150 or 200 yards broad, from the Chinese town of Maimaitchin. The place stands in a desolate valley, and along with two other settlements, one 10 miles, the other 2½ miles distant, has a population of 3000 inhabitants. Kiachta was appointed by the treaty of Nerchinsk in 1689 the sole trading place between China and Russia; but down to 1727 the general trade did not flourish much, because the imperial crown reserved the fur trade as a monopoly in its own hands. From 1727 celebrated fairs were held here in December, when Russian furs and cotton, cloth, and leather were exchanged for tea, silk goods, &c. But since the treaty of Peking (1860), when the treaty ports of China were thrown open to Russian vessels and trade was declared legitimate all along the Russo-Chinese frontier, the trade at Kiachta has declined. The Russian goods are valued at £500,000 a year, the Chinese at £2,000,000.

Kiangsi, Kiangsu, provinces of China (q.v.).

Kiao-chan, or KIAU-CHOW, a port on the south side of the peninsula of Shan tung in China, leased by Germany in 1898. The harbour is silted with sand, but advantageously situated. In and around the town live 200,000 souls.

Kidd, WILLIAM, pirate, was a native of Scotland, born probably at Greenock, and is supposed to have been the son of a worthy Covenanting minister who was put to the torture of the boot, and who died in 1679. The lad went early to sea, saw much hard service privateering against the French, and gained a high reputation for stubborn courage, and in 1690 a reward of £150 from the council of New York city. At this time the American colonies were supposed to be nests of pirates who infested the Indian Ocean, and Cooze, Earl of Bellamont, was sent out by William III. as governor of New York and Massachusetts with special instructions to suppress the pest. A ship of 30 guns was fitted out by a private company in London and given to Kidd, who was furnished, moreover, not only with the usual letters of marque, but with commissions under the great seal both to act against the French and to seize pirates. In January 1697 he reached Madagascar, the chief rendezvous of the pirates, but ere long disquieting reports reached England that Captain Kidd was playing the game of pirate himself. After a two years' cruise he returned to the West Indies, and a few months later had the temerity to go to Boston without securing himself by a satisfactory safe-conduct. In spite of the half promises that had been made him he was arrested and sent to England, where he was tried for piracy and the murder of one of his men. Of the latter charge he was formally found guilty, and hanged at Execution Dock, London, 24th May 1701, protesting his innocence to the last. He had buried a store of treasure on Gardiner's Island, off Long Island, which was recovered and seized, amounting with what was found elsewhere to £14,000.

Kidderminster, a parliamentary and municipal borough and market-town of Worcestershire, situated on the Stour 4 miles above its junction with the Severn, and 14½ miles by rail N. of Worcester, 121 NW. of London. It is a busy, thriving-looking place, chiefly noteworthy on account of its carpet-manufacture (see CARPETS), which was first established here in 1735. Worsted spinning and dyeing are also carried on. Richard Baxter was for fourteen years vicar of the parish, and there is a statue of him (1875). An illustrious native was Sir Rowland Hill; a marble statue of him was erected in 1881 at a cost of £1700. Among the public buildings are the parish church, Early English to Perpendicular in style, with a noble pinnacled tower; a Renaissance town hall (1877); a corn exchange (1855); a free library, and a free grammar school, founded in 1637. Kidderminster was incorporated as a municipal borough by Charles I., and since 1832 returns one member to parliament. Pop. of the entire parish, which includes Lower Mitton or Stourport, (1801) 9639; (1881) 31,033; (1891) 33,326, of whom 21,803 were within the municipal limits.

Kidnapping, the abduction specially of children; the word being derived from *kid*, slang for 'a child,' and *nap* or *nab*, cant for 'to seize.' The law of the subject is given at ABDUCTION; the charge of kidnapping frequently made against Gypsies is dealt with at GYPSIES.

Kidney-bean. See BEAN.

Kidneys, two glands having for their function the excretion of the urine. The human kidneys are situated in the region of the loins, one on each side of the spine, and are imbedded

in a layer of fatty tissue. Their form is distinctive. They possess a convex outer border and a concave inner border, the extremities are somewhat enlarged, and the organ as a whole is compressed from before backwards. The average length of each kidney is a little more than 4 inches, and its usual weight is from 4 to 6 ounces. The left kidney is longer and narrower than the right, and in the female the weight is slightly less than in the male. The concave inner border presents a longitudinal fissure—the hilum—at which the vessels enter; in front there is the renal vein, behind it the renal artery, and most posterior the ureter, which conveys the urine to the bladder. When the sides of the hilum are held apart a deep indentation is seen—the sinus of the kidney—in which the ureter dilates to form a large sac—the pelvis of the kidney. Investing the kidney there is a fibrous coat—the *tunica albuginea*—which readily

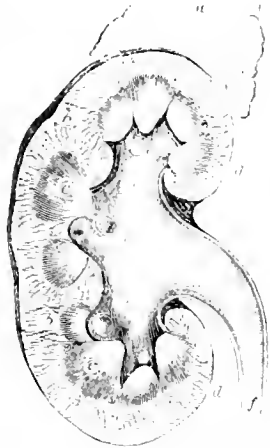

Fig. 1.—Vertical Section of Kidney:

a, suprarenal capsule; *b*, cortical substance of kidney; *c*, medullary substance of kidney; *d*, hilum; *e*, renal vein; *f*, renal artery; *g*, the sinus or pelvis; *h*, the ureter, proceeding to the bladder.

peels off from the substance of the gland to which it adheres by minute processes and fine blood-vessels. At the hilum it turns inwards, and becomes continuous with the sheaths of the vessels. Under cover of this capsule there is an incomplete layer of involuntary muscular fibre. The substance of the kidneys is dense, extremely friable, and of a deep red colour. On making a longitudinal section of the kidney from the convex outer border to the hilum it is seen to consist of two different substances, which are named, from their position, the external or cortical and the internal or medullary substance, arranged in pyramids with their apices towards the hilum.

The *cortical substance* forms by far the greater part of the gland, and sends numerous prolongations inwards between the pyramids of the medullary substance. It is soft, granular, and contains numerous minute red globular bodies diffused throughout it, which are called, from their discoverer, the Malpighian bodies. Its substance is made up of the *uriferous tubes*, capillaries, lymphatics, and nerves, held together by an intermediate parenchymatous substance.

The *medullary substance* consists of pale reddish, conical masses, called the pyramids of Malpighi. They are usually about twelve in number, but vary from eight to eighteen, and their apices (the *papilla*) point towards the hollow space (termed the *sinus* or *pelvis*) which occupies the interior of the gland. The medullary structure is firmer than the cortical, and instead of being granular presents a striated appearance, from its being composed of minute diverging tubes (the uriferous tubes), which run in straight lines through this portion of the kidneys, after having run in a highly convoluted course through the cortical portion. From the base of each pyramid streaks pass through the cortex, named *medullary rays*, and the portions of cortical substance between the rays are called the *interlobular* of the cortex.

The cavity occupying the interior of the kidneys (the *sinus* or *pelvis*) is lined by mucous membrane, which, through the medium of the ureter, is continuous with that of the bladder, and which extends into the tissue of the kidneys, to line the miniferous tubes. The mucous membrane forms a cup-like cavity around the termination of each pyramid, and the cavity, termed the *calyx*, receives the urine from the open terminations of the tubes, and conveys it towards the pelvis, from whence it passes down the ureter into the bladder.

Each kidney is supplied with blood by a renal artery, a large trunk which comes off at right



Fig. 2.—Plan of the Renal Circulation in Man and the Mammalia (from Ludwig):

a, terminal branch of the artery, giving the terminal twig, *at*, to the Malpighian tuft, *at*, from which emerges the efferent vessel, *at*. Other efferent vessels, *at*, *at*, *at*, are seen proceeding from other tufts, and being the equivalent of the numerous tufts, *at*. From this plexus of capillaries, the efferent vein, *at*, springs.

venous radicle, the efferent vessel, emerges from it close to the point at which the artery had entered. The Malpighian body itself, situated in the labyrinth, consists of a rounded bunch or tuft of capillaries, derived from the afferent and terminating in the efferent vessel, and enclosed in a clear and transparent capsule—the capsule of Bowman lined with flattened epithelium. Each capsule is continuous with the uriniferous tube by a narrow neck.

It now remains to consider the respective functions of the Malpighian bodies and the tubes. From the researches of Bowman and others it appears that in animals in which the urinary excretion is passed in an almost solid form (as in birds and reptiles) the tufts are small and simple as compared with those in the kidneys of animals which (like man and most mammals) pass the urinary constituents dissolved in a large quantity of water. On these grounds, as well as from the fact that the anatomical arrangement of the tufts is well calculated to favour the escape of water from the blood, Bowman arrived at the conclusion that the function of the Malpighian bodies is to furnish the fluid portion (the water) of the urine. Recent observations tend to show that the saline ingredients of the urine are also excreted by Bowman's capsule. The arrangement of the convoluted portion of the tubes, with a capillary network on one side of their basement membrane, and secreting epithelial cells on the other, is the exact counterpart of the arrangement in other secreting glands, and there can be no doubt that the functions of the cells in the convoluted portion of the tubes is to separate from the blood the various organic con-

stituents (urea, uric acid, creatinine, &c.) which collectively form the solid constituents of the urine. It does not necessarily follow that these secreting cells undergo rapid decay and renewal; it is more probable that they have the power of selecting certain materials from the blood, and of transmitting them, without the disintegration of their own structure, to the interior of the tube. The physical and chemical characters of the secretion yielded by the kidneys will be considered in the article URINE.

DISEASES OF THE KIDNEYS.

By far the most important are the group included under the general name of Bright's disease, which may be defined as comprising cases where structural changes in the kidneys, usually inflammatory, but without suppuration, lead to the presence of albumen in the urine. Dr Richard Bright published in 1827 researches showing that many cases of dropsy are attended by albuminuria on the one hand, and by marked changes in the kidneys on the other. His observations have been confirmed and extended by many subsequent observers; and it is now agreed that there are three distinct groups of cases, differing much in causation, symptoms, course, and post mortem appearances, to which the above definition applies. These must be considered separately.

(1) *Catarrhal or Parenchymatous Nephritis* (inflammation of the kidneys). In this form the inflammation affects chiefly the secreting structures of the kidney—i.e. the cells lining the tubules. The kidneys are at first much enlarged; in acute cases in the early stage redder than in health; in later stages and in chronic cases paler. If the duration of the disease is long, however, they may ultimately become much diminished in size, so as much to resemble, except in their paler colour, the kidneys in the cirrhotic form of Bright's disease. This disease may often be traced to exposure to cold; frequently complicates pregnancy; and occasionally occurs in connection with most of the eruptive fevers, but particularly scarlet fever, of which it is one of the most common and serious complications. In acute cases it sometimes begins with a rigor and elevation of temperature. Dropsy is almost always one of the earliest symptoms, and often appears first in the skin of the eyelids. Pain in the region of the kidneys, headache, and vomiting are usually present. The urine is scanty, often bloody, and contains albumen and tube casts. Symptoms of *Œremia* (q.v.) often occur. In favourable cases complete recovery takes place in the course of a few weeks, all the symptoms gradually subsiding. Frequently, however, though the severer features of the case disappear, the urine continues to contain albumen, and the disease becomes chronic. Death may result from *Œremia*, from dropsical effusion, especially in the large serous cavities, frequently from the occurrence of some acute inflammation, particularly of lungs, pleura, or pericardium.

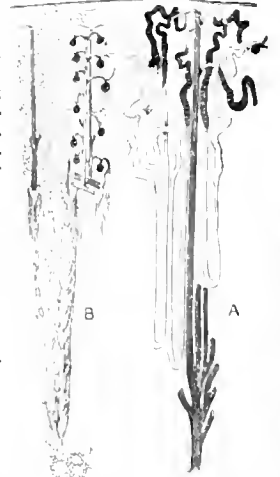

Fig. 3.—Diagrammatic View of Tubules (right side, A) and Blood-vessels (left side, B) of Kidney.

(From Macalister.)

(2) *Cirrhosis of the Kidneys, or Interstitial Nephritis*.—In this form the morbid process consists chiefly in chronic inflammation of the connective tissue of the kidney, which leads to destruction of the tubules and glomeruli by cicatricial contraction. In advanced cases the kidneys are much diminished in size, rough and nodular on the surface, and red in colour. This disease is often traceable to gout, either inherited or acquired, or to chronic lead-poisoning. It is rare before the age of thirty, most common after forty or forty five. The chief feature of this affection is its extremely chronic and insidious nature, which is so marked that it is almost always for some secondary result of the disease that the patient seeks medical advice, and not for symptoms directly referable to the kidneys. The earliest symptom is usually an increase in the quantity of urine, which contains albumen only in small quantities, and may sometimes be quite free from it. Hypertrophy of the heart, with a hard pulse, is one of the most constant features of the disease; and in many cases symptoms due to heart affections are the first which excite the patient's alarm. Persistent headache, unaccountable vomiting or diarrhoea, failure of sight owing to albuminuric retinitis, simple debility, symptoms of uræmic poisoning, cerebral hæmorrhage (apoplexy), or the occurrence of acute inflammation of some internal organ—all these are among the occurrences which may lead to the discovery of this singularly insidious disease. It frequently becomes complicated by addition of inflammation of the kidney tubules (above described) to the primary process, and the symptoms are modified accordingly.

(3) *Waxy or Tuberculous Degeneration of the Kidney*.—As when this degenerative process appears in other organs, the smaller arteries and capillaries are first and most affected; later, other portions of the organ partake in the morbid process. But in the great majority of cases some degree of inflammation of the tubules is also present. Like waxy degeneration elsewhere, it can almost always be traced either to syphilis or to prolonged suppuration. The flow of urine is generally increased in the early stage, and contains albumen. Dropsy is usually present, with some others of the symptoms enumerated above as characteristic of the first form of Bright's disease. But in general the symptoms are rather variable, and could hardly lead to the recognition of the condition present apart from the clue given by the previous history of the case and the occurrence of signs of waxy disease in other organs. In acute cases (first form) prompt and active treatment is necessary, and is often signally successful. Confinement to bed between blankets, light diet, mainly or exclusively of milk, and the production of very free action of the skin and bowels are usually the chief points to be attended to. In the most severe cases wet cupping or bleeding from the arm is sometimes required. Extreme care is necessary till perfect recovery has taken place. In chronic cases warm clothing, with attention to the action of the skin, strict regulation of the diet, avoidance of alcohol, and where possible removal to a warm climate during the cold season can do much to keep the disease in check. Experience has shown that under favourable conditions the course of the disease may be much more gradual than was generally believed by physicians thirty years ago.

Albuminuria without Bright's disease may occur in the course of fevers, in heart disease, and many other morbid conditions. It is now believed by most observers, though the subject is still under discussion, that it may also be present without any actual disease. *Hæmoglobinuria* (impregnation of the urine with the colouring matter of the

blood) is a troublesome, but, except in the case of infants, not a dangerous disease. *Hæmatæmia* (blood in the urine) is indicative of disease in some part of the urinary passages; but it is often difficult to be certain what portion is at fault. Besides Bright's disease, the most common condition leading to it is stone in the kidney or bladder. For *Glycosuria* (sugar in the urine) and *Poluria* (increase in the quantity of urine), see DIABETES.

Stone in the Kidney.—The symptoms attending the passage of a stone from the kidney to the bladder have already been described (see CALCULUS); but it not infrequently happens that a stone formed in the kidney remains there, or, though it enters the ureter, fails to escape, blocking it and preventing the discharge of urine from that kidney. In either case the symptoms are often somewhat obscure and difficult to trace to their true cause. When the stone remains in the kidney blood generally appears from time to time in the urine, and there is persistent pain in the loin, often aggravated by such movements as the jolting of a carriage. Medicinal and dietetic treatment may often prevent the formation of fresh stones, where one has been discharged; and sometimes even seems to lead to the removal by solution of a stone from the kidney. Operation has frequently been resorted to during recent years for the removal of a stone from the kidney, and has in some cases relieved the symptoms, even when no stone has been discovered. When a stone becomes impacted in the ureter the kidney is gradually destroyed, and either atrophies or becomes converted into a large sac containing fluid. The remaining kidney generally becomes enlarged, and carries on the function of excretion; but if its ureter subsequently becomes obstructed in the same way death rapidly ensues.

Suppurative inflammation of the kidney may occur in the course of pyæmia, but usually results from disease of the lower urinary passages (bladder or urethra, hence often called surgical kidney), and is a very fatal disease. The kidneys may become the seat of *tubercular disease*, of *maligant tumours*, of *hydatid cysts*. But none of these conditions are of common occurrence.

Fluctuating or Movable Kidney.—One kidney, more rarely both, may have its attachments to the posterior wall of the abdomen so loosened and elongated that it can move about in the abdominal cavity, somewhat as the intestines normally do. This condition is much more common in women than in men, and may either produce no symptoms, or lead to great discomfort and distress. In the latter case it is usually possible so to adapt a bandage and pad as to restrict the movements of the organ and to relieve the symptoms.

Kidney-stones, the name given to small nodules of reddish-brown ironstone veined with calcite, which are common in the Oxford clay in the sea-cliffs and on the shore north of Weymouth, Dorsetshire.

Kidney-vetch (*Achilleis*), a genus of plants of the natural order Leguminosæ, sub-order Papilionaceæ, containing a number of species, some shrubby and some herbaceous, natives chiefly of the Mediterranean. They have the petals nearly equal in length, and an oval 13-seeded pod, enclosed in the permanent inflated and generally downy calyx. The only British species is the Common Kidney vetch (*A. rubicarpa*), also called *Lady's Fingers*, a herbaceous perennial, with pinnated unequal leaves, and crowded heads of yellow (or sometimes scarlet) flowers. It grows on very dry soils, and is eaten with avidity by cattle, but does not yield much produce. *A. Barba-jovis* (Jupiter's Beard), from the south of Europe, is so

called on account of the long, silky hairs which clothe the leaves, and conspicuous bracts that accompany the flower-heads.

Kidron. See **KEDRON**.

Kieff, one of the oldest towns of Russia, and ecclesiastically one of the most important, stands on the Dnieper, by rail 586 miles SW. from Moscow and 381 N. from Odessa. According to tradition it was founded before the Christian era. In 882 it was made the capital of the Russian principality, and remained so until 1169. Here in 988 Christianity was first preached in Russia by St Vladimir; and ever since that date Kieff has been one of the chief ecclesiastical and intellectual centres of Russia. The town was captured and nearly destroyed by the Mongols in 1240, and it remained in their hands for eighty years. From 1320 to 1569 it was in the possession of Lithuania, then of Poland down to 1654, in which year it was annexed to Russia. The town is built on elevated ground (350 feet above the river), trenched by ravines, and is connected with the opposite bank of the Dnieper by a fine suspension bridge, built in 1851. The most notable institution in the town is the celebrated Petchersk monastery, which is visited by more than a quarter of a million pilgrims annually. Underneath the monastery are a number of caves, containing tombs of the chief saints of the Russian Church. The cathedral of St Sophia, erected in 1037 on the spot where Yaroslaf defeated (1036) the Petchenegs, contains the tombs of the grand-dukes of Russia, and a magnificent altar, ornamented with beautiful mosaics; the interior of the cathedral resembles a labyrinth. The cathedral church of the Assumption harbours the bones of seven saints brought from Constantinople, and has a beautiful belfry with a peal of twelve bells. Altogether Kieff has nearly seventy churches, many of them with gilded domes and pinnacles, which, seen from a distance, give the city a striking appearance. The university, removed here from Vilna in 1833, has four faculties and (1883) 1700 students. There are also theological colleges, a military school, and an arsenal. The industry is unimportant, except tanning and the manufacture of wax candles. Considerable trade is done, especially at the fairs, the most celebrated of which is held during the last half of January. Pop. (1874) 79,773; (1895) 194,300. The fortress of Kieff, begun by Peter the Great in 1706, and now fortified in modern style, occupies a commanding site on the right bank of the Dnieper, and serves as a chief depot for war material.—The *government* embraces great part of the Ukraine, and is bounded on the north-east by the river Dnieper, which with its tributaries, the Priepet and others, performs the functions of drainage. Area, 19,685 sq. m., more than one-half of which is arable and one fifth under wood. Pop. (1897) 3,564,433. Agriculture and horticulture are the chief occupations. The staple industry is the manufacture of beet root sugar (23,000 men employed in 70 factories); spirits, tobacco, flour, machinery, and leather rank next. Trade is still very largely in the hands of the Jews. In Peter the Great's time the government of Kieff embraced the eastern part of the Ukraine and a large portion of middle Russia.

Kickie (*Fragaria Banksii*), a scandent shrub of the natural order Pandanaceae, yielding an edible, aggregated fruit, said to be the finest indigenous fruit of New Zealand. The kickie is found in the northern part of New Zealand. The fruit is a mass of fleshy berries, and the jelly made of it tastes like preserved strawberries.

Kiel, chief town of the Prussian province of Sleswick-Holstein, stands 66 miles N. by E. from

Hamburg by rail, at the head of a deep fjord (11 miles long) of the Baltic, which admits large ships to anchor close to the town. It is the headquarters of the German Baltic Sea navy, and has imperial shipbuilding-yards, slips, dry and wet docks, &c., naval marine stores, a naval academy, a naval officers' school, and an observatory (removed from Altona in 1874). It is also an important commercial port, some 1,100,000 tons of merchandise passing in and out annually. The chief part of its trade is carried on with the towns of Denmark and Sweden; corn, coal, timber, and cattle being imported, whilst coal, flour, beer, butter, cheese, and fish are exported. The industrial activity is considerable, and is mostly exercised in iron-foundries, shipbuilding-yards, corn-mills, breweries, and cabinet-makers' works. Kiel is the seat of a university, founded in 1665, with new buildings completed in 1876; in 1889 it had 85 professors and teachers and 463 students. The castle, built in the 13th century and enlarged by Catharine II. of Russia in the 18th, shelters the university library of 200,000 volumes and a museum with sculptures by Thorwaldsen. The Thanlow Museum contains Sleswick-Holstein carved work of the 15th-18th centuries. The bay is defended by a series of forts placed near its sea entrance. For the Baltic Canal to connect the Elbe and the Bay of Kiel, see **BALTIC SEA**; and **CANAL**. Kiel affords good facilities for bathing. The old town, dating from before the 10th century, has been enlarged by the suburbs of Brunswick and Diestbrook; the latter has beautiful promenades. Pop. (1875) 37,270; (1890) 69,172. Here was signed in 1814 the treaty between Denmark, Sweden, and England, by which Sweden exchanged Pomerania for Norway.

Kielce, the smallest of the Polish governments of Russia, on the Austrian frontier. Area, 3897 sq. m.; pop. (1887) 692,328. The capital, Kielce, 85 miles N.E. of Cracow, has 10,650 inhabitants.

Kiepert, HEINRICH, cartographer and geographer, was born at Berlin on 31st July 1818, and first established his reputation as a map-maker by preparing in co-operation with Ritter the *Atlas of Hellas and the Hellenic Colonies* (1840-46; new ed. 1870). Thereafter he gave his time and energy to constructing atlases of the Orient, especially of the Orient in ancient times, his best-known works in this connection being the maps of Asia Minor, the Ottoman empire in Asia, Caucasus, Palestine, and Turkey, and atlases of the Ancient World (historico-geographical) in various forms, of which the English edition (*Atlas Antiquus*) is familiar to nearly everybody. Kiepert, who conducted the Geographical Institute at Weimar from 1845 to 1852, and from 1859 was professor of Geography at Berlin, wrote, amongst other works, *Lehrbuch der alten Geographie* (1879), *Leitfaden der alten Geographie* (1879; Eng. trans. 1881), and numerous papers, mostly dealing with ancient oriental geography, in the *Proceedings* of the Berlin Academy of Sciences. He died in April 1899.

Kierkegaard, SOREN AABY, the greatest thinker of Denmark, was born at Copenhagen, on 5th May 1813, led the simple but busy life of a thinker and writer, and died on 11th November 1855. He was a very voluminous author. His greatest books are *Either-Or* (1843) and *Studia on Life's Way* (1845); these and many others were published under fictitious names. Kierkegaard applied the Socratic method to the examination of the fundamental philosophical principles of Christianity, regarded not as an organised or church religion, but as the religion of the individual soul. Both his thought and style are singularly original. In dialectical skill, eloquence, and imaginative qualities he is scarcely inferior to Plato; and to

these he joined wit and a love of irony and paradox. He has been one of the most potent influences in modern Danio-Norwegian literature. In his last years he made a bitter attack on the official church. See *Life* by Georg Brandes (in Danish, 1877), and biographical studies by Barthold (in German, 1875-86).

Kieselguhr. See DIATOMS, DYNAMITE.

Kilauea, the great volcano of Hawaii (q.v.).

Kilbowie, in Dumbartonshire, 4 miles NW. of Glasgow, is the seat of the huge sewing-machine works of the Singer Company, which cover 46 acres, and employ about 8000 hands. The town is part of the police-borough of Clydebank, whose population increased from 3830 in 1881 to 10,589 in 1891.

Kilburn. See KINBURN.

Kildare, a county of the province of Leinster, Ireland, bounded by Dublin, Wicklow, Queen's and King's counties, Meath, and Carlow. Its chief town is Naas, and the other municipal towns are Kildare, Kilenlen, Maynooth (where is the Roman Catholic College), and Athy, besides which there are quite a number of small towns. The area is 418,836 acres, or 654 sq. m.; the surface is generally flat and the soil very productive. A great portion of the county belongs to the central Carboniferous plain of Ireland. In the northern part there is a large extent of bog, and the great Bog of Allen covers some 40,000 acres, intersected by elevated ridges of dry ground. From this bog rises the Hill of Allen, a conical rock of porphyry and greenstone, 300 feet high. Towards the south-east the surface rises to meet the hills of Dublin, and in the south to meet those of Carlow. There are a few small woollen, paper, and corn mills, breweries and distilleries, but agriculture is the main occupation. The most fertile and best farmed districts are the valleys of the Liffey and the Greese, besides which rivers the county is watered by the Boyne and Blackwater, both having their source in County Kildare, the Barrow and the Lesser Barrow. The Royal Canal, connecting Dublin with the Shannon, traverses the northern portion, and the Grand Canal traverses the valley of the Liffey. To the south of the town of Kildare is the Curragh of Kildare, an undulating plain of bright green grass covering about 8000 acres; a portion of it forms the Newmarket of Ireland, and on another portion is the Curragh Camp. Kildare returns two members to the imperial parliament. Pop. (1841) 114,488; (1891) 79,206, of whom 87 per cent. were Catholics. Kildare is noted for its antiquities. There are old giant stone pillars at Panchestown, Harriestown, Jigginstown, and Mullamast, and remarkable earthworks near Naas and elsewhere. There are numerous sepulchral mounds on the Curragh, and also the remains of a stone circle. There are five round towers in the county, and the ruins of a great many religious houses and castles. See works by Rawson (1807) and O'Byrne (1807).

Kildare, a town in Kildare county, 30 miles SW. of Dublin. St Bridget (q.v.) founded a nunnery here, and the older name *Devin Ceathill* was changed to *Col-lara*, the cell or church of the oak, from an old tree under whose shadow the saint built her cell. There are remains of three other monastic institutions, and a round tower, the finest in the county, 103 feet high. Kildare was one of the first sees founded in Ireland; its first prelate died in 549. The Protestant see (1550) is now united with Dublin, and the Roman Catholic see forms the diocese of Kildare and Leighlin. After the Norman invasion Kildare became a place of considerable importance, and a parliament was held there in 1309. It suffered severely, however, in

the wars of Elizabeth and during the great Civil War, and has never recovered its former standing, although historically one of the most interesting old towns in Ireland. The rebellion of 1798-99 began in Kildare, where, on the night of the 23d May 1798, a number of officers from Duddin were murdered by the insurgents. Prior to the Union it returned two members to the Irish parliament. Pop. (1861) 1426; (1891) 1172.

Kilia, a town in the portion of Bessarabia ceded by Roumania to Russia in 1878, is situated on the northern bank of the Kilia branch of the Danube, 20 miles NE. of Ismail. It has some fishing and trade. Pop. (1884) 9079. The place was captured by the Russians in 1790, and bombarded by the allied fleet in July 1854.

Kilian, ST, the apostle of Franconia, a native of Ireland, who, sent by the pope as a missionary bishop to the heathen, preached at Würzburg about 690, and was slain by his convert Duke Gozbert for denouncing his marriage with Geila, his brother's widow. Würzburg claims him for its first bishop; his day falls on 8th July.

Kilima-Njaro, an isolated mountain mass in East Africa, standing between Victoria Nyanza and the coast, just within the northern limit of the German East African Company's territory, in 3° 20' S. lat. and 37° 50' E. long. The mass consists of two peaks, or rather craters, Kibo and Kimawenzi, connected by a broad saddle (14,000 feet) studded with lava hills. Kibo was climbed by Dr Meyer in October 1889. Its highest point is about 19,680 feet above sea-level; its crater is 650 feet deep, and 6500 feet in diameter. At the same time he climbed the second highest pinnacle of Kimawenzi, and found it to be more than 17,250 feet high. The crater rim of both peaks is covered with a thick crust of ice. See *Pfeiffermann's Mittheilungen*, vol. xxxvi, No. 1; also H. H. Johnston's *Kilimanjaro Expedition* (1886).

Kilkenny, an inland county of Leinster, bordering on Queen's County, Carlow, Wexford, Waterford, and Tipperary. Its area is 599,732 acres, or 796 sq. m. The proportion of bog is small, and owing to this and the slope of the country the climate is dry, salubrious, and temperate. Vegetation is earlier here than in the rest of Ireland, and the soil along the valleys of the Suir, Nore, and Barrow is very rich. In the northern part there are large tracts of moor devoted to sheep and cattle, but almost nothing has been done to improve the pasturage in the hilly districts. Kilkenny forms for the most part a continuation of the Carboniferous-limestone plain, but to the south and south-east the surface rises to a considerable elevation. In the north there is another hilly region forming part of the Castlecomer anthracite coalfield. At present the output is about 80,000 tons per annum, or more than one half the annual coal production of Ireland. In the western district are the Walsh Mountains. The principal rivers are the Suir, the Barrow, and the Nore, which all rise in the Slieve Bloom Mountains, and after widely-divergent courses empty themselves into Waterford Harbour. The chief towns are Kilkenny, Callan, Thomastown, Freshford, Ulingford, and Castle-comer. Pop. (1841) 202,120; (1891) 87,261, of whom 94 per cent. were Catholics. Prior to the Union Kilkenny returned sixteen members to the Irish parliament, but now the county returns two and the city one to the imperial parliament. The linen manufacture was once a prosperous industry, but is now practically extinct, and the woollen manufacture is nearly so. There are a few breweries, distilleries, tanneries, flou mills, and marble-polishing works.

Kilkenny, anciently part of the kingdom of

Ossory, was formed into a county by King John in 1210, and during the Revolution was held by the Irish for James II. It was made an English settlement after the Norman invasion, and was the scene of a long succession of conflicts between the two races. The Norman remains are very numerous, and among other antiquities are circular groups of stones on Slieve Grian and the Hill of Cloghmaunta, several cromlechs and raths, numerous forts and mounds, five round towers, and monastic ruins at Jerpoint, Rosbercon, Thomastown, Knocktopher, and elsewhere. The most notable castle is Graney, in Iverk, supposed to have been founded by the Earls of Ormonde in 1521, and of which three towers are still standing. The cave of Dunmore, between Kilkenny and Castlecomer, which opens with a natural arch 50 feet high, is noted for its beautiful stalactite chambers and its subterranean stream. At Silverwood and Ballygunnion are the remains of very ancient lead-mines. Manganese, marl, pipeclay, marble, and copper are still found. See J. G. Robertson's *Antiquities and Scenery of Kilkenny* (1851).

Kilkenny, the capital of the county of that name, is also a county of a city and parliamentary borough, returning one member to parliament. It is situated on the Nore, 81 miles SW. of Dublin by rail. Pop. (1851) 19,975; (1891) 11,048. At one time it was the seat of busy linen and woollen manufactures, but very little of either now remains. It is still, however, the centre of a considerable industry in marble-polishing. In the neighbourhood are extensive quarries of shelly black marble, which is in extensive request for chimney-pieces, tombstones, and other purposes. The name is Celtic—*Cil Canice* the church of St. Canice or Kenny, a building dating from 1052 and the largest ecclesiastical edifice in Ireland except St. Patrick's at Dublin. It is in the Early English style, 226 feet long by 123 across the transepts. There are many old sepulchral monuments, and quite close to the south transept are the remains of a round tower still 100 feet high. Other ecclesiastical remains are the preceptory of St. John's, founded in 1211; the Dominican abbey, founded in 1225, still used as a Roman Catholic church; and the Franciscan abbey, founded in 1230. In 1857 was erected the Roman Catholic cathedral, at a cost of £30,000, a handsome building with a massive central tower 186 feet high. On a precipitous rock above the Nore is the famous castle of Strongbow and his son and successor, dating from about 1175, and restored during the 19th century as a place of residence for the Marquis of Ormonde. The grammar school, founded in the 16th century, also stands on the banks of the river, fronting the castle, and here Swift, Congreve, and Bishop Berkeley received their education. Near the city is the Roman Catholic college of St. Kieran. Several parliaments were held at Kilkenny in the 11th century, and even down to Henry VIII. it was the residence, occasionally at any rate, of the lieutenant. It was here that in 1397 was passed the stringent 'Statute of Kilkenny,' meant to prevent the Anglo-Irish from becoming more Irish forbidding intermarriage, &c. and here that in 1642 the Assembly of Confederate Catholics gathered. Cromwell laid siege to the city in 1648, and in 1650 it capitulated on honourable terms. The principal trade of the city is now in provisions, through the port of Waterford, by which it is united both by river and rail. The fable of the 'Kilkenny cats,' which fought till nothing but the tails were left, was a satire on the contentions of Kilkenny and Trishtown in the 17th century about boundaries and rights, which went on till both towns were impoverished.

Killarney, a small market-town in the county of Kerry, 18½ miles by rail SW. of Dublin, 47 WNW. of Cork, and 1½ mile from the lower Killarney Lake. Its importance depends on the crowds of tourists who come to visit the famous lakes. The town has been practically rebuilt, and now possesses some spacious streets with a number of good houses and public buildings. Most notable among the latter is the Roman Catholic cathedral, a very imposing structure, which, along with the Bishop's Palace, was designed by Pugin. There is also a large Episcopal church, a lunatic asylum, a courthouse, and a railway hotel. Pop. (1851) 7,127; (1891) 5,510. There is a small trade in making fancy articles to attract the strangers, principally from the wood of the arbutus, which grows on the islands. On the shores of the lakes are marble-quarries, yielding several varieties—green, red, white, and brown—and also some old copper-mines. Near the town is the seat of the Earl of Kenmare, whose estates were the scene of disturbances, in connection with evictions, during the Irish agitation of 1888-89.

Killarney, LAKES OF, are a series of three connected sheets of water, the lowermost of which is within 1½ mile of the town of Killarney. The outflow is by the river Laune north-west to Castlemain Harbour. These famous lakes are situated in a basin in the midst of the mountains of Kerry, some of which rise abruptly from the water's edge densely clothed with trees from base to summit. Arthur Young called those which surround the upper lake 'the most tremendous mountains that can be imagined, and said that the wooded hills along the margins 'form the most magnificent shore in the world.' This is exaggeration, but the scenery of Killarney is very beautiful, and in some of its aspects unique. It presents, as Arthur Young quaintly said, an admirable mixture of the beautiful and sublime. The lower lake, Lough Leane, covers an area of 5001 acres, and is studded with richly-wooded islands. The largest of these is Ross Island, on which is situated Ross Castle, an old stronghold of the O'Donoghues. Another island is the 'sweet Innisfallen' of Moore's song, and on this is the picturesque ruin of an abbey, founded by St. Finian the leper in the 6th century. The upper lake covers some 430 acres, and is also studded with islands. Between the two is Lough Tore, covering 680 acres. Connecting the upper with the lower and middle lakes is the Long Range, a beautifully-wooded and picturesquely-winding stream 2½ miles long. About midway in its course occurs the famous echo, caused by a lofty rock called the Eagle's Nest. Between the lower and the middle lakes is the fine ruin of Muckross Abbey, founded by the Franciscans in 1440. A peculiarity of the scenery is the luxuriant growth of arbutuses on the islands of the lakes, which add such richness and colour to the general effect. See works by Mr and Mrs Hall (1843-78).

Killiecrankie, a beautiful wooded pass in Perthshire, on the Garry River, 15 miles NNW. of Dunkeld. It is traversed by Wade's Great Highland Road (1732), and by the Highland Railway (1863). For the battle, see GRAHAM (JOHN).

Killigrew, THOMAS, born in 1612, served as a page in the household of Charles I., and was afterwards a dissolute companion of Charles II. in exile and his groom of the bedchamber after the Restoration. He published in 1664 nine indifferent plays, which he tells us were written in nine different cities. He was some time manager of the king's company, and in his patent obtained permission to give the female parts to women. He

died in 1683. Sir John Denham's lines form his best epitaph:

Had Cowley ne'er spoke, Killgrew ne'er writ,
Combined in one, they'd made a matchless wit.

—**KILLGREW, SIR WILLIAM**, his brother, was born in 1606, fought in the Civil War, and died in 1695. His works include a comedy, *Pandora*, and three tragicomedies, *Scindru*, *Ornideses*, and *The Siege of Uchin*.

Kilmainham, a township of Dublin county and a western suburb of Dublin city. Pop. 5391. Here is the Royal Hospital for the reception of wounded and pensioned soldiers. It was originally founded by Charles II., is conducted on similar principles to the sister institution, Chelsea Hospital, and provides for 250 inmates. Near it is the government prison of Kilmainham. The phrase, 'the treaty of Kilmainham,' played a prominent rôle in party political warfare in 1882. The phrase pointed to an alleged arrangement between Mr Gladstone and Mr Parnell (then in Kilmainham gaol), whereby the latter promised to use his influence to prevent agrarian crime in Ireland on condition that a legislative measure altering the Land Act of 1881 was introduced into parliament.

Kilmarnock, the largest town in Ayrshire, on Irvine and Kilmarnock waters, 15½ miles by rail NNE. of Ayr, and 24 SSW. of Glasgow. It received its name *Kil-arno-Emin-oc* (Gael., 'church of my little Emin') from the dedication of its church about 1200 to an Irish saint of the 7th century; and in 1591 it was made a burgh of barony under the Boyds, from which date its hose and bonnet making grew into thriving industries. The great carpet manufacture was introduced in 1777, and the printing of calicoes in 1770, of shawls in 1824; tweeds, wineys, boots, &c. are also manufactured; and the Glasgow and South-Western Railway works were transferred hither in 1858. The staple trade, however, is in connection with iron, owing to Kilmarnock's situation in a great mineral district; and the October cheese-fair (established 1855) is second to none in the kingdom. The Boyd's Dean Castle, 1 mile NE., was reduced by fire to ruin in 1735; and the town itself, which has suffered twice from fire (1668 and 1800), and once from flood (1852), has few buildings of interest. The town hall (1805), the courthouse (1852), the corn exchange (1862), with its Albert tower 110 feet high, and the new academy (1876) may be noticed, as also may a statue of Sir James Shaw (1848), and the Kay Park of 41 acres (1879), with its Burns' monument, a tower 80 feet high. Of Burns (q.v.) and of the Covenanters Kilmarnock has memories; and it was the birthplace of Alexander Smith. Since 1832 it has united with Rutherglen, Dumbarton, Port Glasgow, and Renfrew to return one member to parliament, its parliamentary boundary having been extended in 1885. Between 1875 and 1890 its valuation increased from £61,847 to £96,195. Pop. (1841) 19,398; (1881) 25,841; (1891) 28,147. See M'Kay's *History of Kilmarnock* (1848; 4th ed. 1880).

Kilogramme, a thousand grammes. 2.2046 lb. See METRIC SYSTEM. *Kilogramme metre* is the amount of work done in lifting one kilogramme one metre. 7.23398 foot pounds. *Kilowatt*, a thousand metres. 3280.9 feet. 0.96211 mile. *Kilowatt*, unit of activity in Mechanics. one thousand watts = 1.3406 horse power = 1.3591 cheval vapeur.

Kilrush, a small seaport of Ireland, on the northern shore of the Shannon estuary, 36 miles W. of Limerick. It is resorted to for sea-bathing, and exports grain and timber. Pop. 3865.

Kilsyth, a town of Stirlingshire, 13 miles NE. of Glasgow, with quarries and coal and iron mines.

Founded in 1665, it was made a burgh of barony in 1826. Here, on 15th August 1645, Montrose with 4900 followers almost annihilated 7000 Covenanters under Baillie (Gardiner's *Good Civil War*, vol. ii. 1889). A remarkable religious revival took place here in 1839, originating in the preaching of W. C. Burns, afterwards missionary to China. Pop. (1851) 3949; (1881) 5405; (1891) 6073.

Kilt. See HIGHLAND COSTUME.

Kilwa. See QUILWA.

Kilwinning, a town of Ayrshire, on the Garnock, 3½ miles NNW. of Irvine and 26 SW. of Glasgow. The stately Tirrensonian abbey, founded in the 12th and demolished in the 16th century, was dedicated to Winmin, an Irish saint, who is said to have founded a church here about 715. The traditional birthplace of Freemasonry (q.v.) in Scotland, Kilwinning has also been celebrated since 1488 for archery; its July shooting at the popinjay, placed on the steeple (105 feet high), is described in Scott's *Old Mortality*, and continued till 1870. Eglinton Castle (1798), the seat of the Earls of Eglinton (q.v.), is 1½ mile S.E.; and the Eglinton Ironworks (1846) afford employment. Pop. (1861) 3921; (1881) 3469; (1891) 3835. See works by Wylie (1878) and Lee Ker (1883).

Kimberley, capital and chief town of Griqualand West, South Africa, the most important inland town of the Cape Colony, is situated 540 miles NE. of Capetown by rail (30 hours). Pop. (1891) 28,718, more than half natives. The British flag was first hoisted at Kimberley in November 1871; but Griqualand West did not become an integral portion of the Cape Colony till October 1880. The climate is healthy, though hot in summer; the neighbouring country, in all places where water can be obtained, fertile. The wants of the town have been abundantly provided for by water-works carried out at a cost of nearly half a million sterling, for which water is obtained from the Vaal River. On the outbreak of the Transvaal war it was invested by the Boers, but after a siege of over three months it was relieved on 15th February 1900. The rise of Kimberley has been rapid; and its situation is favourable to its further development. It holds the direct road from Capetown and the sea to the Orange Colony, the Transvaal, and the immense territories to the north; and is important to travellers and 'cup-country' traders as the emporium and starting place for the interior. There are a handsome town-hall, post-office, high court, public library, and botanic gardens. Kimberley owes its existence to the diamond-mines, the working of which dates only from July 1871, and of which the most important, known as Du Toit's Pan, Bultfontein, De Beer's, and Kimberley Central, were amalgamated into one huge company, with a share capital of £3,950,000. The number of diamonds found elsewhere in the whole world is comparatively insignificant (see CAPE COLONY, Vol. II, p. 734; also DIAMOND, Vol. III, p. 791). Kimberley is also the name of a fertile district in the Fitzroy basin, in northern West Australia, where gold was found in 1893.

Kimchi, DAVID, the most eminent Jewish grammarian and exegete, was born about 1160, probably at Narbonne, where he spent the greater part of his life, and died about 1235. His father, Joseph Kimchi, was the author of a number of commentaries and other theological works. His brother Moses wrote similar works and a Hebrew Grammar. His own celebrity, however, far exceeds theirs, and even with competitors like Rashi and Ibn Ezra he has preserved his place as the most popular of Jewish commentators. His Grammar, *Mekhalol*, and his Lexicon, *Seder hash arasham*, have to a certain degree been the basis

of all subsequent Hebrew grammars and lexicons. His commentaries include almost all the books of the Old Testament. That on the Psalms was edited by Schiller-Szinessy (Camb. 1885).

Kimmeridge Clay, the lowest series of the Upper Oolite, consists of dark, bluish gray shaly clay, which is sometimes bituminous and occasionally (as at Kimmeridge in the Isle of Purbeck) passes into a shale so rich in bituminous matter as to be used as a fuel. In other places the clay is calcareous, and contains nodules of argillaceous limestone or septaria. Near its base it sometimes shows sandy layers and clay ironstone. The series attains a maximum thickness of 600 to 660 feet.

Kimpolung, a town of Wallachia, stands in a valley at the foot of the Carpathians, 80 miles NW. from Bucharest. Pop. 9090.—Another town of this name exists in the extreme south of Bukowina. Pop. 5534.

Kin, NEXT OF. When a person dies intestate his real property devolves, according to English law, on his Heir (q.v.), and his personal property is distributed among his next of kin. The degrees of kindred are divided into lineal and collateral. The lineal consists of the ascending, such as father, mother, grandfather, grandmother, paternal and maternal, and so on *ad infinitum*; and the descending, such as son, daughter, grandson, grand-daughter, and so on *ad infinitum*. The collateral kindred consists of brothers, sisters, uncles, aunts, &c., and the children of such *ad infinitum*. The mode by which the civil law computed the proximity of degree was this: it allowed one degree for each person in the line of descent exclusive of him from whom the computation begins, and in the direct line counted the degrees from the deceased to his relative; but as regards collaterals it counted the sum of the degrees from the deceased to the common ancestor, and from the common ancestor to the relatives. Thus, a brother was in the second degree, counting one to the father, and one from the father to the brother; a nephew, and also an uncle, a great grandfather and a great-grandson, were all in the third degree; a son and a father were in the first degree; and so on. This mode of computing the degrees of kindred has been adopted in the law of England and Ireland.

When a person dies intestate, leaving personal property, there are two classes of rights to which the next of kin are entitled: one is the right to administer the estate, or to take out letters of administration; the other is the right to a share of the property itself. As regards the right of administration, the court has discretion to appoint a fit person, but a preference is to be given to the widow or widower, and to the next of kin. Among the next of kin those are to be preferred who are nearest in degree according to the above computation: thus, a son or father is preferred to a brother, grandfather, or grandson; and those to a nephew, uncle, great-grandson, or great-grandfather; and so on. In distributing the personalty the widow takes one-third if there be children or other descendants, one-half if there be none. Subject to this claim of the widow, the next of kin take according to the Statute of Distributions, which slightly differs from the order of the civil law as to the degrees of priority: thus, the children exclusively take the whole if children survive; if some of the children are dead, leaving issue, then the issue collectively of each dead child take an equal share with the living children, by what is called the principle of representation. If there are none nearer than grandchildren, each family of grandchildren take the share of the child whom

they represent, and the issue of a deceased grandchild also take the share of their parent. If there are no descendants, the father, if alive, is entitled to the whole. If he also is dead, then the mother and the living brothers and sisters (together with the issue of deceased brothers and sisters collectively) take each one share. After these are dead, then grandfathers and grandmothers, paternal and maternal, and nephews and nieces, if alive, take each a share. The right of representation—i.e. the right of the children of a deceased person being one of a class (and who, if alive, would have been one of the next of kin) to represent him, and take his share—applies as far as the children of brothers and sisters, but no further. The heir-at-law is one of the next of kin, and takes his share of the personalty, though he also gets all the real estate. The half-blood counts among the next of kin equally with the whole blood; males are not preferred to females; and the rule of primogeniture has no application.

In Scotland the rules of priority among the next of kin vary considerably from the above order, which prevails in England and Ireland. The children, being entitled to an absolute legal share called Legitim (q.v.), take the father's property in two characters—one part as legitim, the other as being next of kin—and the result is often different from what obtains in England. Moreover, in Scotland, though the heir-at-law may be one of the next of kin, still he is not entitled to take such share unless he collate the heritable estate (resign it to the executors). The degrees of kindred are not counted in exactly the same way. The father never can take more than one half, nor the mother more than one third, while any of the brothers and sisters, or their issue, are alive. The half-blood does not share equally with, but in an inferior degree to the full blood. See the tabular statement in Paterson's *Compendium of English and Scotch Law*.

Kinabalu. See BORNEO.

Kinburn, or KULEBEN, a former fort of south Russia, situated opposite Otchakoff, on a long narrow sandbank which forms the southern boundary of the estuary of the Dnieper. Paul Jones first suggested to Suvaroff that it should be fortified; it figured prominently in the Russo-Turkish wars of 1771-74 and 1787; and during the Crimean war it fell before the allies, October 17, 1855. The fortifications were razed in 1860.

Kincardineshire, or THE MEARNS, a maritime county of Scotland, with Aberdeenshire and the Dee on the N., Forfarshire and the North Esk on the S. and W., and the North Sea on the E. The rocks are granite, gneiss, sandstone, conglomerate, mica slate, clay slate, limestone, and trap. Area, 383 sq. m., or 245,346 acres, of which 120,050 are in cultivation, and 23,153 in wood. The county may be divided into four sections—viz. the Coast, the 'Howe' of the Mearns, the Grampians, and Deeside. The coast-land and north of the 'Howe' is of superior quality, and rents from £2 to £3, 10s. an acre. The 'Howe' forms a continuation of the Valley of Strathmore (q.v.). The Grampians, running across the country from east to west, parallel to the Dee, with an average breadth of from 7 to 8 miles, cover about 80,000 acres; one of the peaks, Mount Battock, is 2555 feet high. The Deeside portion of the county is a comparatively narrow strip of light, sharp soil. There are few manufactures in the county. The principal towns and villages are Stonehaven (q.v.), the county town; Bervie, a royal burgh; Laurencekirk, a borough of barony; Banchory; and Johnshaven. Of the objects of antiquarian interest the most noted are Dunnottar Castle (q.v.) and Raedyke's Camp, an

entrenchment seemingly on the Roman method, in which it has been supposed that the ancient Caledonians under Galgacus encamped prior to their battle with the Romans under Agricola. Kincairdineshire was the birthplace of George Wishart, Robert Barclay, Dr J. Beattie, and Dr Thomas Reid; and the father of Robert Burns was born in Dumortar parish. Pop. (1801) 26,349; (1871) 34,630; (1881) 34,460; (1891) 34,647.

Kinchinjunga, or KANCHANJANGA, a peak of the Himalayas, between Sikkim and Nepal, 28,176 feet in altitude.

Kindergarten, the name of a kind of school or training-place for young children—name and thing imported from Germany. The principle was first propounded (1826) and the system invented by Friedrich Froebel (q.v.). He was early impressed with the insufficiency of the teaching and training given in the ordinary infant-school, and with the fact that the loving instinct of the mother remained merely an instinct, which required for the training of the child thoughtful guidance and direction. He saw that the teaching in the infant-school was to a large extent traditional; that the selection of subjects and exercises depended on fashion, or upon the likings or prejudices of the teacher, and not upon a genuine knowledge of the nature of children; and that the whole procedure was based upon an induction of facts and phenomena which had been hastily made, and rested upon no firm ground of principle. He therefore set to work to study the ways and doings of infants from their birth, and to note down systematically what kind of mental food and what kind of bodily activity Nature prompted them at each stage of their existence to prefer. He reached the following principles: (*a*) That Education means a harmonious development of all the bodily and mental powers; (*b*) that the *spontaneous* is the raw material and the only element that is valuable in education, and that the teacher must connect all his instruction with these, and graft it upon the spontaneous activity of the child; (*c*) that the work of the teacher is not to give knowledge *ab extra*, but to supply material, means, and opportunities in a rational and harmonious order for the child's mind spontaneously to work upon; and (*d*) that in the presentation of their materials or occupations there must be no break (*in Natura non datur saltus*), because all occupations which train must be developed out of each other. The early materials for instruction are called *gifts*, because they are presented to the child only when his nature and stage of development call for them. The province of the educator is to map out the world of early childhood, and to engineer—i.e. to give each step in—the paths to knowledge or power in each subject; the province of the teacher is to apply this general knowledge to particular cases, and with loving care and delighted patience to provide the right mental food—the most suitable activities for each hour and stage of development. His complete aim is the systematic cultivation of all the powers in complete equilibrium. Hence, while the infant-school goes too much into work and drill, Froebel's system calls for attention to the individual child; he weaves the work into 'play' (spontaneous activity), and he evolves 'drill' out of the free individual desire for society. Hence Froebel's large use of song and dance. He respects freedom and the right order of development so much that he would not give a word to a child until a mental necessity and desire had been created by an ordered set of experiences for that word; and he cultivates the senses and the hand with the utmost care, so that perfectly accurate perception and comparison may produce true and

clear conceptions, which again give rise to true and just judgments. 'All the byways to untruth,' says Miss Shirreff, 'such as exaggeration, confusedness of mind, inaccuracy of speech, are cut off.' The child is not *tought*, but *led* by a set of ordered experiences to the perception of the principles of number (*Arithmetic*) and of space (*Geometry*); and his senses and powers of hand and eye are cultivated by an elaborate series of exercises. The steps in Froebel's system are (1) *Spontaneity* or *Play*, which, however, in a child is always serious and never frivolous; (2) direction of this towards external fact and truth; (3) weaving of spontaneous powers into ordinary occupations; (4) development into self-culture, independent action, a love of knowledge, beauty, and society. The process, like the process of Nature, is slow, tranquil, and organic; but no part of it requires to be undone. The child sees, imitates, or reproduces and invents new forms; these are the three steps in each subject for each pupil. Its most earnest disciples give to it the name of *The New Education*.

The system has made great way in America, and is now making way in England. There is a Froebel Society, which consists of a large number of thinkers and workers in education. The London and Birmingham school boards have introduced the system; and several training colleges are working upon its lines.

The best English books as yet on the subject are Laurie's *Kindergarten Manual*; Miss Shirreff's *Kindergarten* (1876) and *Kindergarten at Home* (2d ed. 1889); Heerwart's *Muse for the Kindergarten* (1877); Kohler's *Praxis* (trans. by Miss Garney, 4th ed. 1889); *The Kindergarten*; *Froebel Society's Papers* (1880); Barnard, *Froebel's Kindergarten*; Karl Froebel, *Explanation of the Kindergarten*.

Kinderscot Grit, name given to the coarse grits and flag-stones which occur towards the base of the Millstone Grit of England (see CARBONIFEROUS SYSTEM). The rock forms the tableland of Kinder-scot in the Peak county. The grit is quarried at Eyam Moor, Derwent Edge, and other places, and is used for engine-beds, foundations, and reservoir work.

Kindly Tenant. See BORTENS.

Kinematics is the science which treats of pure motion. It involves the fundamental conceptions of space and time and takes no direct cognisance of force or mass. Strictly speaking, any kinematical problem dealing with motions that exist in nature is at bottom dynamical, and every dynamical problem is of necessity approached in the first instance on its kinematical side. Thus, to take a familiar example, Kepler's laws of planetary motion were purely geometrical and kinematical statements, from which Newton deduced the dynamical law of universal gravitation. Again, the *Nautical Almanac* is essentially a book of kinematical statistics, giving the positions of the important heavenly bodies at definite successive intervals of time, and not infrequently the rates of change of position; and the calculation of these statistics has a strict dynamic basis.

Kinematics may be regarded as a geometry of position into which the idea of time or duration has been introduced. Thus, change of position, regarded as taking place continuously in time, leads to the idea of velocity, linear and angular. Velocity itself is, of course, subject to change, and this change, regarded as taking place continuously in time, leads to the idea of acceleration, linear and angular. The distinction of linear and angular as applied to velocities and accelerations is very necessary for a clear study of the kinematics of systems of points, such as plane and solid figures, rigid or deformable, or of the kinematics of fluids.

Rotation, strain, twist, vortex are important cases. The kinematics of solid figures is a subject of growing importance to the mechanic and engineer; so much so that in the kinematics of machinery we have a highly-specialised branch of the subject. A glance at any ordinary piece of mechanism, from a steam engine to a sewing machine, shows how various are the relative motions of the wheels, rods, cranks, belts, and other pieces that build it up. The function of a machine is dynamic—viz. to transform energy to a certain end—but this must be effected by suitable kinematical arrangements. In all modern treatises on dynamics and mechanics a section is devoted to a preliminary study of kinematics. Reuleaux's *Kinematics of Machinery* (trans. 1876) deserves particular mention.

Kinetics. See DYNAMICS, ENERGY, MATTER.

Kinetoscope. See EDISON, ZOETROPE.

King (U.S. *king*, from *kin*, 'a kin,' 'a tribe,' and the termination *-ing*, 'belonging to.' Hence *kinging* is 'man of the tribe,' 'chief'). For the origin of the kingly power, see the article GOVERNMENT; for the relation of King to people in Britain, see ENGLAND (HISTORY OF), PARLIAMENT; and for the position of kings in other countries, see the section on the constitutions of these countries.

King, WILLIAM RUFUS, vice-president of the United States, was born in North Carolina, 6th April 1786, and was admitted to the bar in 1806. He was a member of the legislature for three years, was returned to congress as a War-Democrat in 1810, and represented Alabama in the senate from 1820 to 1844. He was then minister to France for two years, and a senator again from 1848 to 1853, when he became vice-president. He died, however, on 18th April of the same year.

King-at-arms. See HERALD.

King Country. See WAKATU.

King-crab (*Limulus*), a curious animal, the last of its race, usually referred to a special group, Xiphosura, within the spider and scorpion class

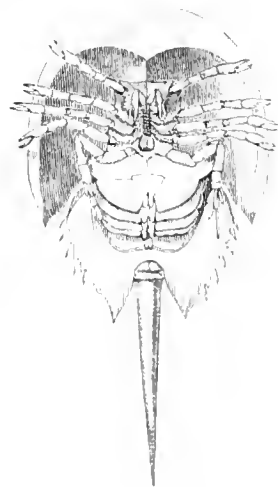

Fig. 1.—Under-surface of King-crab (*Limulus polyphemus*).

Arachnida. A large convex chitinous buckler covers the head and thorax, a flatter hexagonal shield protects the abdomen, while a long spear runs on from the hind end. There are twelve pairs of appendages on the ventral surface, a pair in front of the mouth, five pairs of legs, the bases of which surround the mouth and are masticatory, and a cover or operculum which overlaps five pairs of flattened abdominal appendages, used in swimming, and bearing peculiar respiratory organs known as gill books. On the top of the large buckler there are two large compound eyes and near the middle line two simple eyes. The internal structures are no less peculiar. The sexes are separate, and the spineless larvae present a curious resemblance to Trilobites.

The king crabs attain a length of over two feet. They live on muddy bottoms at a depth of 2 to 6

fathoms, where they sometimes swim slowly about or more frequently burrow their way in the mud by alternately bending and straightening their

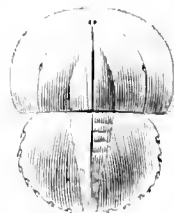
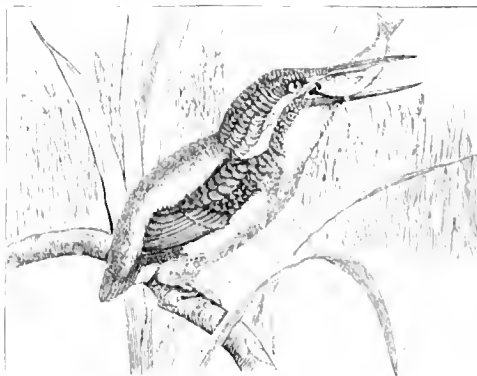

Fig. 2.—Young King-crab, just hatched (greatly enlarged).

spine is used for pointing arrows, and in tropical America the shell sometimes serves as a ladle. See E. Ray Lankester, 'Limulus an Arachnid,' *Quart. Jour. Micr. Sci.*, vol. xxi. 1881; also vols. xxiii. xxiv.

Kingfisher (*Alcedo ispida*), a well-known British and European bird, in the order of pies or Picarie, famous for its brilliant plumage and fish-bone nest. Though it measures only about 7 inches in length from the tip of the beak to the end of the tail, it is rendered conspicuous by the flashing feathers, which are predominantly blue and green. To watch the kingfisher is difficult, for it is shy and wary, and the powerful wings are used in singularly rapid flight. The fish-catching bill is large and strong; the legs are short and weak, but the toes are strengthened by being joined for the greater part of their length. The bird frequents the banks of rivers and lakes throughout Europe; and in Britain is most at home in the south of England. The cry is faint but shrill, like *tee* often repeated. The kingfisher feeds chiefly on small fishes, which are caught by a dexterous dive, carried to the perch, killed by a few blows on a branch, and swallowed whole. The bones are afterwards disgorged, and used in part to form the nest. This is hidden at the end of a hole bored in the bank, and is often anything but clean. The birds generally live in pairs away from their fellows, whose intrusion on the appropriated preserves is jealously resented.



Kingfisher (*Alcedo ispida*).

The seven or eight eggs, which are laid in April, are almost spherical in form and very white, as is often the case in hidden nests. Within the family Alcedinidae, of which the common kingfisher is type, there are numerous genera with representatives in

most parts of the world. The pied kingfisher of India and Africa (*Ceryle rudis*) and the belted kingfisher of North America (*Ceryle alcyon*) are common forms. A sub-family (Daceloninae) includes numerous more omnivorous kingfishers with stouter, flatter bills. Of these the great laughing jackasses of Australia (Dacelo) are notable representatives.

The kingfisher is the old halcyon, 'whose dead body carefully hung by a single thread always turns its beak towards the wind,' a popular and still surviving notion to which Shakespeare makes more than one reference. With the halcyon the imagination of the ancients played lovingly, for to them the bird was Aleyone the daughter of Eolus and wife of the king of Trachis, the son of the morning star, 'who, mourning in her youth for her lost husband, was winged by divine power, and now flies over the sea, seeking him whom she could not find, sought throughout the earth.' 'The bird is not great,' as Socrates continues in Lucian's dialogue, 'The Halcyon,' 'but it has received great honour from the gods because of its lovingness; for while it is making its nest, all the world has the happy days which it calls halcyonidae, excelling all others in their calmness.' So Aristotle, quoting Simonides, says that the halcyon has its young about the turn of the year in winter, 'when Zeus gives the wisdom of calm to fourteen days. Then the people of the land call it the hour of wind-hiding, the sacred nurse of the spotted halcyon.' See R. Bowdler Sharpe's *Monograph of the Alcedinidae or Kingfishers*; Ruskin's *Engle's Nest*; and HALCYON DAYS.

King George's Sound, an inlet 5 miles north and south, and 5 miles broad, at the south-west angle of West Australia, which is an excellent roadstead, and contains two landlocked recesses, Princess Royal and Oyster Harbours. Albany (q.v.), on Princess Royal Harbour, is a port of call for mail-steamers. The fortification of the sound has been recommended by some English military authorities, and an imperial naval depôt has been proposed.

Kinghorn, a royal burgh of Fife, on the Firth of Forth, 3 miles S. of Kirkecaldy by rail. It has shipbuilding-yards, a bleachfield, manufactures of flax and glue, and golf links. Alexander III. was killed (1286) at Kinghorn Ness, and a monument was erected on the spot in 1887. Pop. 2035.

Kinglake, ALEXANDER WILLIAM, historian, was born at Wilton House, near Taunton, in 1809, and was educated at Eton and Trinity College, Cambridge. He was called to the bar at Lincoln's Inn in 1837, and speedily acquired a lucrative practice; but he retired from the profession in 1856, in order to devote himself to literature and politics. He had already published, in 1841, *Eastern*, a work of eastern travel, written in a graphic and poetic vein, yet with great truthfulness to nature, which has always remained one of the most popular books of English travel. He was returned for Bridgwater in the Liberal interest in 1857, took a prominent part against Lord Palmerston's Conspiracy Bill in 1859, and in 1860 warmly denounced the annexation of Savoy and Nice by France. In 1854 he went out with Lord Raglan to the Crimea, where he had every facility for watching the progress of the war. After his return he undertook the defence of the British commander in his *History of the War in the Crimea* (8 vols. 1863-87). As the history was very largely based upon Lord Raglan's papers, it has been regarded by some as a prejudiced narrative of the war; but from the literary point of view opinion is practically unanimous that it is one of the finest historical works of the 19th

century. The criticism of Napoleon III. and the second empire was so searching that the work gave great offence at the Tuileries, and its circulation was prohibited in France during the Empire. Replies have been made to strictures upon other actors in the war, and occasionally with success. But the history remains on the whole a wonderfully accurate, brilliant, and minute record of the great struggle with Russia. In 1868 Kinglake was again returned for Bridgwater, but was unseated on petition. He died 2d January 1891. See *Life* by Innes Shand prefixed to the new edition of *Eastern* (1896).

Kinglet. See GOLDEN-CRESTED WREN.

Kings, THE FIRST AND SECOND BOOKS OF, in the English Authorised Version titled *The First Book of Kings*, commonly called the *Third Book of Kings*, and *The Second Book of Kings*, commonly called the *Fourth Book of Kings*. In the ancient Rabbinical enumeration, implied in Josephus and followed in the Peshito and by Jerome, the Book of Kings (*Melachim*) was reckoned one, ranking fourth and last in the series of the 'earlier prophets' (after Joshua, Judges, and Samuel); the division into two first appears in the Septuagint translation, where they are called the third and fourth 'of the Kingdoms' (*Basilicium*, Heb. *Melachoth*), the books of Samuel forming the first and second. This division was copied by the Vulgate, whence it passed into the 'common' usage of Christendom. The separation between Samuel and Kings is itself not original; for the first two chapters of Kings, concluding the life of David, are consecutive with 2 Sam. ix.-xx. and by the same hand. The books of Kings as we now have them are evidently a compilation, and careful examination shows that they have passed through more than one redaction. In their composition at least four elements can be distinguished: (1) In 1 Kings, xi. 41, reference is made to 'the book of the acts (chronicles) of Solomon, and for the reigns of subsequent kings there is very frequent mention of 'the book of the chronicles of the kings of Judah,' and of a corresponding book of the Kings of Israel. The exact nature of these chronicles cannot now be determined; but the probability is that they were themselves compilations, chiefly digests of a statistical and annalistic character, further epitomised by the writer of the canonical book. (2) The official records of the temple at Jerusalem, though nowhere expressly named, must have been directly or indirectly the source of much of the information given about the worship there, especially under the reigns of Solomon, Joash, Ahaz, and Josiah. (3) The book owes most of its vividness and picturesqueness to materials derived from a series of unofficial narratives, having their origin chiefly in the northern kingdom, and in which the acts of the prophets had special prominence. To this category belong in particular the history of Elijah (1 Kings, xvii. xix., xxi.), and the much more complicated series of passages relating to Elisha, for the northern kingdom; and the story of the man of God from Judah (1 Kings, xiii.), for the southern. (4) The main redactor has contributed the chronological scheme of synchronisms in which the histories of the two kingdoms are brought together under one view, and has given a pragmatical tone to the narrative by undertaking, in the case of each king, an estimate of his religious character and work. This is done in the spirit of the Deuteronomic legislation, and it may be inferred with certainty therefore that the main redaction did not take place till after the reformation of Josiah. The phraseology of such passages as 2 Kings, viii. 22; xiv. 7; xvi. 6 ('unto this day'), implies an earlier date than the fall of the kingdom of Judah; but

evidence of a later pen is found in 2 Kings, xvii. 19, 20; xxiii. 26, 27, while 2 Kings, xxv. 27 *seqq.*, brings us down to a far advanced period of the exile. Important variations (especially in the series of rather disconnected notes which form a large part of the history of Solomon) between the existing Hebrew text and that which must have lain before the LXX. translators show that the book was still in a somewhat fluid state at a very much later date.

For discussion of the critical problems, see Wellhausen in the fourth edition of Bleek's *Einleitung* (1878), reprinted in his *Compendium des Hebräisches*, &c. (1889). Of expositions, those of Thénius (2d ed. Leip. 1873), Keil (2d ed. 1876; Eng. trans. 1872), Bähr (in Lange's *Bibeldwerk*, 1866; Eng. trans. 1877), Rawlinson (in *Speaker's Commentary*), and Reuss (*La Bible*) may be mentioned.

King's Bench. See COMMON LAW.

King's College. London, an institution adjoining Somerset House, Strand, founded by royal charter in 1828, and confirmed by act of parliament in 1882, and on the fundamental principle 'that instruction in the Christian religion ought to form an indispensable part of every system of general education for the youth of a Christian community.' The college being strictly in connection with the Church of England, divinity lectures are a regular part of its routine. The usual university education for young men is provided in theology, literature (ancient and modern), science, engineering and applied science, and medicine. It has also a school of fine art, and a department for the preparation of candidates for the civil service. The instruction is adapted for students above the age of sixteen, but there is a school (1830) for boys in connection with the college, with workshops for mechanical training. There is a branch at Kensington for the higher education of ladies; also evening classes for students occupied during the day. The museum has a collection of models and instruments. For a sketch of the rise and progress of the college, see *The Celebration of the College Jubilee* (1881).

King's or Queen's Counsel are certain barristers at law, in England and Ireland, who have been appointed by letters-patent. The office is entirely honorary, but it gives a right of precedence in all the courts, according to the date of appointment. The appointment practically belongs to the Lord Chancellor. In spite of their title, they are not prevented from being retained and acting for ordinary clients, except that in defending prisoners and acting in suits against the crown they require a special license from the crown, which is, however, never refused. In Scotland there is no such distinction, but the offices of Lord Advocate and Solicitor-general are practically equivalent. The appointment is for life, but in case of disgraceful conduct the letters-patent are revoked, as was done in 1862 to Edwin James, who, in 1873, applied in vain for restitution.

The Queen's Counsels' robes are of silk instead of the ordinary (alpaca) 'stuff' of which the junior's gown is made; and 'taking silk' is thus the common phrase signifying that an 'outer' barrister has become a Queen's Counsel or Q.C. 'Taking silk' is frequently injurious rather than advantageous to a professional career. A Queen's Counsel is prohibited by legal etiquette from taking a good deal of minor business which fell to his share as a junior, and 'silk,' a stepping-stone to the great men, is a stumbling block to the small. When a junior has reached the position in which he feels justified, or is forced by the public opinion of his circuit, to 'apply for silk,' his demand is very rarely refused, or at most postponed, and the honour is little more than a necessary incident in

every successful legal career. Henry Brougham, indeed, was debarred for some years from what was in his case a professional right by the personal antipathy of George IV. and Lord Eldon, and it was not until 1827, on the accession to power of George Canning, that Brougham received a patent of precedence which clothed him in silk and gave him all the professional advantages without the actual title. But this is a striking and almost a solitary exception. Of late years colonial barristers have been gratified with the title of Queen's Counsel conferred by the Lord Chancellor, on representation made by the governor of the colony through the Secretary of State.

King's County, an inland county of Ireland, in Leinster, is bounded on the W. by the Shannon, which separates it from Roscommon and Galway. It is 20 miles long from north to south by 58 wide. Area, 493,985 statute acres, or 772 sq. m. Of this 122,154 acres were under crops in 1889; and of this again nearly one-half was grass, whilst 24½ per cent. was corn and green crops (oats, barley, potatoes, and turnips). Twenty-three per cent. of the total area was covered with bogs, including a large part of the Bog of Allen. The population has steadily decreased—(1841) 146,857; (1861) 90,013; (1881) 72,852; (1891) 65,563, of whom 58,264 were Roman Catholics. The surface is flat, except for the Slieve Bloom Mountains (1733 feet) on the south boundary. The soil, a light loam of medium depth, resting on limestone gravel, is of average fertility. The Grand Canal traverses the northern portion of the county, and joins the Shannon. The river Barrow separates it from Queen's County on the south-east. King's County, constituted a shire in 1557, and named in honour of King Philip, returns two members. In the north-west is Clonmacnois Abbey, founded in 548, one of the most interesting ecclesiastical ruins in Ireland. At Birr Castle Lord Rosse erected his great telescope. The chief towns are Tullamore (5098), Parsonstown or Birr (4955), and Portlaurington (2357).

King's or Queen's Evidence. See AP-PROVER.

King's Evil. See SCROFULA.

Kingsley, CHARLES, born at Holne vicarage, Dartmoor, Devon, 12th June 1819. After education partly at King's College, London, he went up to Magdalen College, Cambridge, and took his degree in 1842—first-class in classics, senior optime in mathematics—and was immediately ordained to the curacy of Eversley in Hampshire, of which parish he became rector in 1844. There he lived for the remainder of his life, having married a daughter of Mr Pascoe Grenfell in the year in which he was presented to his living.

His dramatic poem, *The Saint's Tragedy, or The True Story of Elizabeth of Hungary*, an 'admirable representation of mediæval piety,' appeared in 1848, and was immediately followed by two works of a very different character, *Alton Locke* and *Yeast*, both published in 1849. These brilliant novels are the work of a Radical, a 'Christian Socialist,' and deal with modern social questions in a bold and a strikingly original manner. The hero of *Alton Locke*, 'tailor and poet,' is found in a London workshop. In *Yeast* the condition of the English agricultural labourer is dealt with by one whose sympathy with the people is aristocratic, not democratic, whose radicalism is Christian, and not sceptical, whose enthusiasm never degenerates into unreason, and whose most brilliant invective is always balanced by common sense. The influence of these books at the time was enormous; and if Kingsley wrote nothing more of the same character, it was not so much that time had modified his views as that his

views had modified the times. For two or three years previous to the publication of these novels Kingsley had thrown himself with all the ardour of youth and of his own impetuous nature into various schemes for the improvement of the condition, material, moral, and religious, of the working-classes, a subject of which we all hear a good deal at the present day, but which was somewhat strange in 1844. In this work he was associated with Mr Maurice, the recognised leader of the movement known as 'Christian Socialism'; and he published under the well-known pseudonym of 'Parson Lot' an immense number of articles on current topics, especially in the *Christian Socialist and Politics for the People*. In 1853 appeared *Hypatia*, one of his most fascinating works, a vigorous and brilliant picture of early Christianity in conflict with Greek philosophy at Alexandria in the beginning of the 5th century. *Westward Ho!* followed in 1855, and the presentation of Elizabethan England and the Spanish Main, of Devonshire worthies and their Spanish foemen, is as lifelike as anything to be found in the whole range of romantic literature. The tone of the book is hearty, English, Protestant, free, and, like the author himself, at once strong and tender. In *Two Years Ago* (1857) he sketched with a master hand the North Devon scenery so dear to the west countryman; and *Hereward the Wake* (1866), a novel of the days of the Conqueror, brought the noble series of works of fiction to a close. In 1860 the university of Cambridge had chosen the author of *Hypatia* and *Westward Ho!* to be professor of History, and his inaugural lecture was published at the end of that year under the title of *The Limits of Exact Science as applied to History*. *The Roman and the Teuton* (1864) is also based upon his Cambridge lectures.

In 1869 Kingsley resigned his professorship and was appointed a canon of Chester; and in 1871 he made the voyage that he had so long contemplated, to the tropics, of whose scenery he had already written so enthusiastically; and on his return to Eversley from the West Indies he gave to the world one of its most charming books of travel, *At Last*. In 1873 Kingsley was appointed a canon of Westminster and chaplain to the Queen. He died at Eversley on 25d January 1875. His *Life*, by his widow, in 2 vols., published in 1876, is a biography of deep and sustained interest. Kingsley was by nature hot tempered, enthusiastic, and combative, yet infinitely sympathetic and tender of heart; his 'muscular Christianity' (a phrase he disliked) was cheerful and robust; he had great and varied information, a keen wit, and a mind's eye that ever looked below the surface. His collected works fill 28 volumes (1879-81). Among these, besides those already named, and many volumes of sermons, are *Gleanings* (1854), *The Heroes* (1856), *The Water Babies* (1863), *Town Geography* (1872), *Prize Idylls* (1873), *Health and Education* (1874). Of a sixpenny edition of the chief books (1889-90) millions were sold.

Kingsley, HENRY, brother of the foregoing (born 1830, died 1876), was educated at King's College, London, and Worcester College, Oxford. From 1853 to 1858 he resided in Australia, and on his return commenced his career as a writer of fiction with a vigorous picture of colonial life in *Geoffrey Hamlyn* (1859). To this succeeded *Ravenshoe* (1861), his masterpiece; *Austen Elliot* (1863); *The Milliners and the Barbons*, another novel of Australian life and manners (1865), &c. His ideal of life is a noble and a healthy one; his works, which show little skill in the construction of the plots, contain much that is pathetic, without any tinge of sentimentalism. His style is rather vigorous than highly cultivated. For two years

(1870-71) Kingsley edited the *Edinburgh Daily Courier*.

King's Lynn. See LYNN.

Kingsmill Islands, another name for the Gilbert Islands (q.v.).

King's Mountain. See FERGUSON (PATRICK).

Kingston, chief town of Frontenac county, Ontario, is situated at the head of Lake Ontario and at the mouth of the Cataracti Creek, 161 miles by rail ENE. of Toronto. It has a number of handsome public buildings, and is the seat of the Royal Military College of Canada (1876), of Queen's University (1841), with museums and an observatory, and of the Royal College of Physicians and Surgeons (1854) and the Women's Medical College (1883) affiliated to it. Here also are a business college and a collegiate and training institute for teachers. The city has, besides excellent railway facilities, good water-communication by the lake, the St Lawrence, and the Rideau Canal, which last connects it with Ottawa. It possesses a large, sheltered harbour, with an active trade, and strongly fortified; and, besides busy shipyards, has many factories of locomotives and stationary engines, machinery, leather, boots and shoes, agricultural implements, wooden wares, &c. Grant Allen and George Romanes are both Kingston men. Kingston is the seat of an Anglican bishop and of a Roman Catholic archbishop. Its site was occupied by the old French fort of Frontenac. The town was the capital of Canada from 1841 to 1844. Pop. (1881) 14,091; (1891) 19,264.

Kingston, the commercial and political capital of Jamaica (q.v.), stands on the north side of a landlocked harbour, the best in the island, and, for its size, one of the best in the world. Pop. (1891) 46,542. It was founded in 1693-1703, after the neighbouring town of Port Royal had been destroyed by an earthquake. From this place, afterwards rebuilt, Kingston is distant 6 miles, the breadth of its noble haven; while with Spanish Town, towards the interior, it has since 1846 been connected by railway. In 1758 Spanish Town was made the capital of Jamaica, but in 1872 the seat of government was removed to Kingston. Kingston was visited in 1880 by a violent hurricane, and in December 1882 well-nigh consumed by fire. The city, having a slope to the sea of 1 in 60, is well drained, but the harbour is filthy. With a gravel soil and a dry and temperate climate, maximum 93 in hot season, minimum 56 in cold it is a healthy place. The most interesting public building is the Old Church, where Benbow the 'old sea dog' is buried. There are tram cars, and the water-supply is good. The imports have an annual value of from £1,300,000 to £1,500,000, the exports from £500,000 to £700,000. See the annual *Handbook of Jamaica and Jamaica in 1896*, published by the Institute of Jamaica.

Kingston, capital of Ulster county, New York state, stands on the right bank of the Hudson, 54 miles S. of Albany. It is a railway and canal terminus, and is the centre of extensive transit trade by steamer. Enormous quantities of blue-stone flags are forwarded from Kingston, which is also a principal centre of the hydraulic-cement business, and contains a number of breweries, tanneries, flour mills, foundries, brick yards, and other manufacturing concerns. Pop. (1880) 18,344; (1890) 21,261.

Kingston-on-Hull. See HULL.

Kingston-upon-Thames, a municipal borough and market town of Surrey, 12 miles SW of London, lies on the right bank of the Thames, here crossed by two bridges, one of stone completed 1828 and freed 1870, and the other an

iron railway viaduct. Of late years, with its suburbs of Norbiton, Surliton, and New Malden, it has rapidly increased in size, its easy access to London, coupled with its facilities for boating and the pleasant surroundings of the neighbourhood, notably Hampton Court, Bushy and Richmond Parks, having attracted large numbers of residents. Population of the parish, (1801) 4438; (1831) 7257; (1881) 35,829; (1891) 41,886, of whom 27,059 were within the municipal limits. The parish church, of which William Coxé the historian was once rector, has some fine monuments; the county council buildings, costing £36,000, were undertaken in 1890. In history, however, Kingston has figured somewhat conspicuously: in 838 it was the scene of a great council, convened by Egbert, king of Wessex, and his son Ethelwulf; seven of the Anglo-Saxon kings were crowned here, as recorded on the coronation-stone still standing near the market-place; King John, who granted the town its first charter, was a frequent visitor in 1204-15; in 1264, during the civil war with Simon de Montfort, Kingston Castle (of which no traces now remain) was captured by Henry III.; Fairfax made the town his headquarters in 1647; and a year later took place in the neighbourhood the last fight between the royalists and Roundheads, when Lord Holland and the Duke of Buckingham were defeated. At Ham Common lived Gay's 'Kitty,' Duchess of Queensberry. See Biden's *History of Kingston-upon-Thames* (1832).

Kingston, WILLIAM HENRY GILES, a popular writer of boys' stories, was born in London, 28th February 1814. His father was a merchant in Oporto, and there much of his youth was spent. At first a merchant, he had already published two stories and a book of Portuguese travel, when in 1851 he found the work of his life in the immediate success of *Peter the Whaler*, his first book for boys. During the next thirty years he published more than 120 similar books, all simple, vigorous, and healthy in tone; full of daring adventures, hairbreadth escapes, and all the magic of the sea which he not only loved but knew. His heart never lost its wholesome glow of admiration for any form of human heroism, and the simple and sincere veracity of his style easily generated a corresponding sympathetic enthusiasm in his young readers. And he possessed in no small share the pictorial imagination which enabled him to borrow colour from travellers' accounts of countries he had never seen. Among his most popular books were *The Three Midshipmen*, *The Three Lieutenants*, *The Three Commanders*, and *The Three Admirals*. Kingston took an active interest in many philanthropic schemes, as the mission to seamen, and assisted emigration. He was knighted by the queen of Portugal for his services in helping to bring about a commercial treaty between England and Portugal. He died at Willissen, 5th August 1880.

Kingstown, a populous and important suburb of Dublin, 7 miles SSE. from the G.P.O. Trains run in 15 minutes to Dublin. Previous to 1817, when the harbour works were commenced, it was merely a fishing village known as Dunleavy. On the occasion of the visit of George IV. in September 1821 its name was changed to Kingstown. The situation of the town and the invigorating air have made Kingstown a favourite residence for the well-to-do classes having business in Dublin. The mail packets sail from Kingstown to Holyhead twice a day, morning and evening. There is little general trade, though the harbour, completed by the Admiralty in 1839 at a cost to the imperial treasury of £825,000, is one of the finest in the United Kingdom. The east pier is 3500 feet in

length; the west, 5000 feet, enclosing an area of over 250 acres, with a depth of from 13 to 27 feet. Vessels drawing as much as 24 feet can come alongside the quay at any state of the tide. Kingstown is within the parliamentary division of South Dublin. Pop. (1890) 25,000.

Kingstown, capital of the British island of St Vincent, in the West Indies, stands at the south-west extremity of the island, on a large bay, at the foot of one of the spurs of Mount St Andrew (about 2000 feet). Pop. 5593.

King-te-chin, the principal seat of porcelain manufacture in China, in the province of Chiang-hsi, on a small river which falls into Lake Po-yang from the east. Pop. 500,000.

King Williamstown, capital of a division of the same name on the Buffalo River, in the SE. of Cape Colony, 80 miles ENE. of Grahamstown, and by rail (1877) 42 WNW. of East London, on the coast. It has considerable trade, military barracks and stores, and a college. Pop. about 8000.

Kinkajon (*Cercopithecus caudicolubus*), a quadruped of the group Ateoidea, and allied to the raccoons and coatis. It has six incisors, one canine tooth, and five molars in each jaw, the three hinder molars tuberculous. The kinkajon is larger than a polecat, has a yellowish woolly fur, climbs trees, feeds on fruits, honey, &c., as well as on small animals. It is a native of the warm parts of America, from central Mexico to the Rio Negro of Brazil. It used to be classified with the lemons, to which it bears not a little resemblance, particularly in its habit of sitting on its hindquarters and feeding itself with its hands. Sir R. Owen was one of the first to show that here appearances are deceptive, and that the animal is a true carnivore.

Kinkel, JOHANN GOTTFRIED, a German poet and writer, was born at Oberkassel, near Bonn, 11th August 1815. He studied theology at Bonn and Berlin, and then lectured on theology, afterwards on poetry and the history of art, at the university of Bonn. But, becoming involved in the revolutionary movement of 1848, he was imprisoned in the fortress of Spandau, whence, however, he escaped with the help of his wife and Karl Schurz. Settling in London, he earned his living by teaching German until 1866, when he was appointed professor of Archaeology and Art at Zurich. There he died, 13th November 1882. As a poet Kinkel's fame rests upon the epics *Otto der Schatz* (1846; 56th ed. 1881), a graceful poem of the chivalry of the Rhine; *Der Grobshäutler von Antwerpen* (1872; 4th ed. 1887); *Margret, eine Dorfjüngferliche* (1872); *Tanngrä* (1883; 3d ed. 1886); two volumes of *Gedichte* (1843-68); and a drama, *Nimrod* (1857). He also wrote a history of art (1845); a series of essays on art subjects (1876); and monographs on Rubens (1874), Feiligrath (1867), &c. See Lives by Strodtmann (1859), Am Rhyu (1883), Lübke (1893).—His first wife, JOHANNA (1810-58), a distinguished musician, wrote with her husband, *Erzählungen* (1849). After her death appeared her novel, *Hans Inles in London* (1860).

Kinnaird Head. See FRASERBURGH.

Kino, an astringent substance resembling Catechu (q.v.), the concrete exudation of certain tropical trees, especially of *Pterocarpus marsupium*, a native of the forests of Madras and Ceylon. East Indian kino is the kind which now chiefly occurs in commerce, and is the ordinary kino or *gam kino* of the shops. It is in small angular glistening fragments, the smaller reddish, the larger almost black. Thin pieces are ruby red. It is brittle and easily powdered, has no smell, but has a very astringent taste. Bengal kino is a similar astringent substance, produced by *Bateca frondosa* (see BATEA).

Botany Bay kino is the produce of *Eucalyptus resinifera*. The astringency of kino is due to tannin and pyrocatechin. It is employed in certain forms of diarrhoea as *compound kino powder* (with opium and cinnamon). The *infusion of kino* forms a good gargle for the uvula. Kino serves in India as a yellowish-brown cotton dye.

Kinross-shire, the smallest Scotch county after Clackmannanshire, lies between Perthshire and Fife, and, measuring $9\frac{1}{2}$ by $12\frac{1}{4}$ miles, has an area of 78 sq. m., or 49,812 acres, of which 3327 are water. Most of the drainage belongs to Loch Leven (q.v.), from which the surface rises to encircling hills 734 to 1573 feet high. A separate county since 1252 and earlier, Kinross-shire unites with Clackmannanshire to return one member to parliament. Pop. (1801) 6725; (1851) 8924; (1881) 6697; (1891) after adjustment of areas with Perth and Fife, 6637, of whom 1920 were in the county town, Kinross, 27 miles NNW. of Edinburgh, and near the west end of Loch Leven. See JEANES Mackay's *Fife and Kinross-shire* (1890).

Kinsale, a municipal borough and seaport of County Cork, at the head of Kinsale Harbour, which is formed by the estuary of the river Brandon, 24 miles SSW. of Cork by a railway (1863). Down to the Union Kinsale returned two members; thenceforward one until 1885. The harbour, landlocked, is about 2 miles long, and is capable of containing 300 ships. Its once flourishing trade has passed to its rivals Cork and Queenstown. On the Old Head of Kinsale, a promontory stretching southward into the Atlantic, stands a lighthouse whose light, 236 feet above high water, is visible for 21 miles. Pop. (1851) 5596; (1891) 4605. In 1601, 3000 Spaniards landed at Kinsale in order to fight for the O'Neill confederacy. Here James II. landed on 12th March 1689, and here he re-embarked in July 1690. In the following October the fort was captured by Marlborough.

Kintyre, or CANTIRE (Gael. *ceann tìr*, 'head-land'), a long, narrow peninsula of Argyllshire, between the Atlantic and the Firth of Clyde, extending 42 miles south by westward, and $4\frac{1}{2}$ to $11\frac{1}{2}$ miles broad. At the north end it connects with the mainland by the isthmus of Tarbert, $1\frac{1}{2}$ mile broad, between East Loch Tarbert, a bay of Loch Fyne, and West Loch Tarbert. The surface is diversified by a ridge of low, moorish hills, with many lochs, the highest point being Ben an Tuire (191 feet). Coal is found at Drumblende, 4 miles to the west of Campbelltown (q.v.). Machilish Bay, on the west coast, just beyond, possesses noted golling links. A fair proportion of the soil is in cultivation. A lighthouse (1787), 297 feet above sea level, stands on the Mull of Kintyre (the *Epithema Praemontorium* of Ptolemy), which is overhung by Ben an Lice (1405 feet), and is only 13 miles distant from Ireland. The ancient seat of the kingdom of Dalriada (q.v.), Kintyre ranked till the 17th century as part of the Hebrides, being held successively by Norsemen, by the Macdonalds of the Isles, and by Campbells. Its antiquities include the ruins of the Cistercian abbey of Saddell, of the castles of Dunaverty, Dundonald, Saddell, and Skipness, and of many forts and pre-Reformation chapels. See T. P. White's *Archaeological Sketches in Kintyre* (1873).

Kioto. See KYOTO.

Kipchaks, a Turkic people, who in the 11th century were settled in the steppes of south-east Russia, between the Ural and the Don, north of the river Kuma. After the death of Genghis Khan, one of his four sons, Batu, conquered (1238-43) nearly all the central and southern districts of Russia, and founded the great empire of the Golden Horde on the Kipchaks, fixing his magnificent camp (Turkic, *ardu*,

'camp,' hence the word *Hard*) on the Volga. They gradually acquired the rudiments of civilisation as they came into contact with the cultured peoples of the west and south. The Golden Horde and the eastern branch, the White Horde or eastern Kipchak, were united about 1378; but this joint empire was broken up by Tamerlane in 1390-95. Out of the fragments were formed the small khanates of Astrakhan, Kazan, the Crimea, &c., all of which were eventually absorbed by Russia. The modern descendants of the western Kipchaks are the Tartars of Kazan, Astrakhan, the Crimea, &c. (see TARTARS). The descendants of the eastern Kipchaks are the Kirghiz (q.v.), of whose three hordes the middle one is still called Kipchaks. See Howorth, *History of the Mongols* (1880).

Kipling, RUDYARD, story-teller, was born at Bombay, 30th December 1865, the son of John Lockwood Kipling, C.I.E., principal of the School of Art at Lahore in the Punjab, himself the author of *Boast and Man in India* (1891). Rindyard was educated at Westward Ho and elsewhere in England, but returned in 1880 to India, where he began to contribute verses, tales, and articles to Indian journals, making his literary debut at Lahore in 1884 (in *Echoes*). But it was by his *Departmental Dittos* (1st ed., Calcutta, 1886), *Plain Tales from the Hills* (Calcutta, 1888), and *Soldiers Three* (Allahabad, 1889), that he became well known in England, and sprang at once into the front rank of popular favourites. *The Story of the Gadsbys, In Black and White, Under the Doobars, Woe Willie Winkie*, and *The Phantom Rickshaw*, followed close on the heels of *Soldiers Three*, and like it formed part of an *Indian Railway Library* published at Allahabad. *The City of Dreadful Night* illustrates certain aspects of Calcutta. More ambitious, though hardly so successful, was the longer tale, *The Light that Failed* (1891). *The Barrack-Room Ballads* (1892), in verse more remarkable for vigour of diction and swing of rhythm than for the refinements of poetic form, were amongst his most brilliant successes; and *Naulakha* (1892), a longer tale, was produced in conjunction with Mr Balestier. *Life's Handicap* (1891) and *Maun Inventions* (1893) are other collections of short tales and sketches, not exclusively Indian in subject; and the magazines compete for contributions from his pen. In 1892-96 he lived mainly in the United States.

From the first his sketches of the glories and disgraces and views of Tommy Atkins abroad, and of the more mysterious and unfamiliar life of the natives, were felt equally to 'palpitate with actuality.' He seems from an intimate and first-hand knowledge of the minds and hearts alike of natives and soldiers to render their own ideas in their very words; and he deals directly and simply with the elemental passions of human nature, with love and hate, with shame and fear, with joy and misery. The interlocutors, both high and low, are frequently far from refined, reverent, or sinless; and it has been objected to his tales of Anglo-Indian life that the tone is both flippant and cynical, and that too many of both his men and women seem to be 'playing at tennis with the seventh commandment,' as he himself words it. But unquestionably he commands true realistic power, and in his smallest masterpieces, pathos and humour, the ghastly and the comic, are combined with the *crispezza* of an everyday experience. His inimitable *Jungle Book* (1894) was followed by a *Second Jungle Book* (1895). There were more *Soldier Stories* in 1896, and the poem called *Sera Sera Seas*. *Captain Corcoran's* (1897) was a tale of fishing life on the banks of Newfoundland. *The Day's Work* (1898) was a collection of stories.

Kippis, ANDREW, D.D., F.R.S. (1725-95), born

at Nottingham, studied at Northampton under Dr Doddridge, and from 1753 was minister of a dissenting congregation in Westminster. He wrote much for the magazines, helped to found the *Annual Register*, edited Lardner's works (11 vols.), wrote *Lives* of the four Earls of Shaftesbury and Dr Doddridge, and edited the new edition of the *Biographia Britannica* (5 vols. folio, unfinished, 1778-93).

Kirby, WILLIAM, entomologist, was born at Winesham Hall, Suffolk, 19th September 1759. He was educated at Ipswich grammar-school and Caius College, Cambridge, graduated B.A. in 1781, took orders in the following year, and was first curate, after 1796 rector, of the quiet Suffolk parish of Barham, where he died, July 4, 1850. His principal works are *Monographia Apum Angliæ* (Ipswich, 1802), and *Introduction to Entomology* (4 vols. 1815-26), the latter written conjointly with Mr Spence. The first was very favourably received both at home and abroad, and at once secured for Kirby a distinguished place among European savants. The second work is written in the form of letters (fifty-one in number), giving a familiar account of the habits, instincts, and uses of insects, and remains a classical masterpiece of *vulgarisation* in the best sense of the word. To the seventh edition Spence contributed an appendix giving the history of the book. Kirby also contributed a variety of very important entomological papers to the *Linnæan Transactions*. His greatest discovery in this department of science is that of the genus *Stylops*—the type of a new order of insects, living in the larva state parasitically in the bodies of bees. He also wrote one of the *Bridgewater Treatises*, entitled *Habits and Instincts of Animals* (1835). Kirby was one of the first members of the Linnæan Society (founded in 1788), honorary president of the Entomological Society, and Fellow of the Royal and Geological Societies. See the *Life* by the Rev. John Freeman (1852).

Kircher, ATHANASIUS (1601-80), German Jesuit, philologist, physicist, and inventor of the magic lantern. See HIEROGLYPHICS; and *Life* by Brischlar (Würzh, 1877).

Kirchhoff, GUSTAV ROBERT, physicist (1824-87), became professor in Berlin University in 1874. He distinguished himself in the departments of elasticity, the mechanical theory of heat, optics, and especially of spectrum-analysis. See SPECTRUM; and *Life* by Boltzmann (Leip. 1888).

Kirghiz, or KIRGHIZ-KAZAKS, a people spread over the immense territory bounded by the Volga, the Irtysh, Chinese Turkestan, Ala-tau Mountains, the Syr-Daria, and Aral and Caspian Seas. A few tribes of Kalmucks also live within these boundaries. Over this vast tract reigns a dismal monotony; the country has scarcely any important elevation or depression, excepting the Mogudjar Mountain in the north-west; no river of consequence runs through it, no great forest breaks the uniformity of the scene; it is a vast steppe, containing 850,000 square miles, sterile, stony, and streamless, and covered with rank herbage of five feet high. It abounds in lakes and marshes, the water of which is generally brackish and unfit for use, and in the southern portion lies the Kara-Kum, an extensive salt desert. The Kirghiz are a Turkish race, and speak a separate dialect of the eastern Turkish. They have from time immemorial been divided into the *Great*, *Middle*, and *Little Hordes*. The first of these wanders in the south-west portion of the Russian steppe, partly in the Russian possessions north of the Ala-tau and Khokand, and partly in the territory of China. They are subject to the rulers within

whose bounds they dwell. The Middle Horde possesses the territory (called the country of the Siberian Kirghizes) between the Irtysh, Lake Balkhash, Khokand, and the territory of the Little Horde; and also a great portion of the Russian province of Semipalatinsk. Russia has gradually absorbed them, the result being finally achieved by the victory over Khiva in 1873, and the formation of the new province of Amu-Daria. The Little Horde (now more numerous than the other two together) ranges over the country bounded by the Ural, Tobol, the Siberian Kirghiz, and Turkestan. Like the Middle Horde, they are claimed as subjects of the czar, though partly independent. This horde is partly agricultural, partly nomad. A small offshoot of the Little Horde has, since 1801, wandered between the Volga and the Ural River, and used to be under the rule of the governor of Astrakhan.

The total number of the Kirghiz-Kazaks amounts to 2,500,000—a smaller number than in former times when unchecked and uncontrolled they moved from one end of central Asia to the other. The Kirghiz are noted for their unbounded love of adventure, wit, and poetical disposition. As nomads they have retained most of the characteristics of their race, they still cling to their ancient habits and customs, and Islam has never taken a firm hold on them. Since the suppression of *baranta* ('forays') they have lost their warlike spirit, although they still abhor sedentary life and cannot be persuaded to settle and live by agriculture. Russian schools in the steppes have hitherto vainly striven to transform these inveterate nomads.

KARA-KIRGHIZ, called by the Russians Dikokameni Kirghiz ('Wild rock Kirghiz'), a nomadic people living mostly in the mountains between the Issik-kul and the Kuen-Lun, and extending from the eastern frontier of Fergana to the Muzart, are the oldest Turkish nomads of historical record. They are divided into *Onq* and *Sol* (right and left wings), and into the subdivisions of Sult, Saribagish, and Sujak. Their total number amounts to 324,000 souls, and their cattle is estimated at upwards of 700,000 head. The dialect of the Kara-Kirghiz has retained more of the ancient character than that of the Kirghiz-Kazaks, and their epic poetry is particularly interesting. See M. N. Godekow's finely illustrated Russian work on the Kirghiz and Kara Kirghiz of the Province of the Syr-Daria (Tashkend, 1889 *et seq.*).

Kirin, capital of the province of Kirin, in Manchuria, stands on the river Sungari, 220 miles NE. of Monkden. It has an arsenal and powder-factory. Pop. 75,000 to 100,000.

Kirkcaldy, a seaport and market-town of Fife, on the Firth of Forth, 15 miles N. of Edinburgh. Including the suburbs of Linktown and Newtown of Abbotshall on the west, and Pathhead, Sinclairtown, and Gallatown on the north east, it is nearly 4 miles in length; hence the name 'The Lang Toun.' It was created a royal burgh in 1450, and, with Dysart, Kinghorn, and Burntisland, sends one member to parliament. Its harbour is small and shallow, but there is wet-dock accommodation for ships of considerable burden, and a bill was passed in 1890 for the construction of an entirely new harbour on a large scale. Its manufactures are spinning flax, tow, and jute, and bleaching and weaving linen yarns, which are extensively carried on, the products being the usual varieties of linen cloth; mechanical (including marine) engineering on a large scale; iron-founding; and tanning. There are also several pottery-eries. The manufacture of floorecloth and linoleum has been developed into a great trade, and Kirkcaldy is the chief sent of

this growing and important manufacture. There is also a direct export trade to the United States, which in 1884-90 averaged over £75,000 annually. Pop. of parliamentary burgh (1841) 5704; (1871) 12,422; (1891) 17,324; of royal burgh, as extended in 1876, (1891) 27,155. Kirkecaldy is the birthplace of Adam Smith; and Edward Irving and Thomas Carlyle were teachers here.

Kirkcudbright, STEWARTRY OF, a county of south-west Scotland, washed on the south for 50 miles by the Solway Firth, and elsewhere bounded by Wigton, Ayr, and Dumfries shires. Measuring 41 by 38 miles, it has an area of 954 sq. m.; is watered by the Nith, Urr, Dee, Fleet, and Cree; and in the south-east sends up conspicuous Criffell (1867 feet), on the north-west border Merriek (2764), the loftiest summit in the south of Scotland. The rocks are mainly Silurian, with intrusive granite and carboniferous patches; the soil is variously extremely fertile and extremely barren. Little more than a fourth of the entire area is in cultivation, though great improvements have been effected since the foundation in 1809 of the Stewartry Agricultural Society. Nearly 31 sq. m. are occupied by woods. Towns are Kirkcudbright, New Galloway, Castle Douglas, Dalbeattie, Gatehouse, Creetown, and Maxwelltown; and the antiquities include the Devil's Dyke, Threave Castle, and the ecclesiastical ruins of Dundreman, Lincluden, New Abbey, St Mary's Isle, and Tongue-land. The history of the Stewartry is sketched under GALLOWAY; among its worthies have been Samuel Rutherford, Paul Jones, Thomas Brown, and Alexander Murray. It returns one member to parliament. Pop. (1891) 29,211; (1851) 43,121; (1881) 42,127; (1891) 39,985.

KIRKCUDBRIGHT, the county town, 30 miles SW. of Dumfries by a branch-line (1864), is beautifully situated on the left bank of the Dee, which soon begins to broaden into Kirkcudbright Bay, opening into the Solway Firth six miles below. Its name (pron. *Kirkcudbray*) is derived from the church of St Cuthbert, as old at least as 1164; and it is a royal burgh (1455), uniting with Dumfries, &c. to return one member. Chief buildings are the court-house (1868) and town-hall (1879); and a lattice-bridge (1868), 500 feet long, spans the Dee. The ivy-mantled ruins of the castle built by Maclellan of Bombie in 1582 still dominate the town. Pop. (1841) 2696; (1891) 2533. See Maxwell's *Stewartry of Kirkcudbright* (3d ed. Castle Douglas, 1878), and other works cited at GALLOWAY.

Kirkdale Cave, in the vale of Pickering, Yorkshire, 28 miles W. of Scarborough, is famous for the numerous remains of Tertiary mammals which have been found in it. It was discovered in 1821, in the cutting back of an oolitic limestone rock in which it is situated. It was examined by Buckland, and fully described by him in his *Reliquiæ Diluvianæ*. Its greatest length is 245 feet, and its height is so inconsiderable that there are only two or three places where a man can stand erect. The fossil bones are contained in a deposit of mud that lies on the floor of the cave; this is covered by stalagmite formed by the water, highly charged with carbonate of lime, dropping from the roof. The remains of the following animals have been discovered: hyæna, tiger, bear, wolf, weasel, elephant, rhinoceros, hippopotamus, horse, ox, deer, hare, rabbit, water-rat, raven, pigeon, lark, and duck.

Kirke, COLONEL PERCY (c. 1646-91), served three years as an officer in Tangiers. After the battle at Sedgemoor (1685), his men inflicted fearful atrocities upon the unhappy followers of Monmouth and their suspected sympathisers, as to make their nickname, 'Kirke's Lambs,' a byword for cruelty.

Kirke early deserted to William's side, and helped to raise the siege of Londonderry.

Kirkham, a market-town of Lancashire, 8½ miles W. by N. of Preston. It has a grammar-school (1673), and manufactures of cotton, flax, sail cloth, sacking, and cordage. Pop. (1851) 2777; (1891) 4003.

Kirkintilloch, a town in Dumbartonshire (detached), on the Forth and Clyde Canal, 7 miles NNE. of Glasgow. Its Celtic name *Cairpentia borch* ('fort at the end of the ridge') referred to a strong fort on Antoninus' Wall, which has left some remains; and as early as 1170 it was made a burgh of barony. Chemicals, iron, &c. are manufactured. In the southern suburb, Lenzie, are the large Barony lunatic asylum (1875) and the Glasgow convalescent home (1864). Pop. (1851) 6342; (1881) 8029; (1891) 10,312.

Kirk-Kilissia (the 'forty churches'), a town of Turkey, 104 miles NW. of Constantinople, with which it has a brisk trade in butter and cheese. It is famed for its confections. Pop. 16,000, of whom two-thirds are Bulgarians.

Kirkmaiden. See JOHN O' GROUT'S.

Kirk-session, the lowest court in Presbyterian churches, being the governing body of a particular congregation, and composed of the minister and elders of the congregation. See PRESBYTERIANISM.

Kirkstall Abbey, a Cistercian abbey in Yorkshire, stands 3 miles NW. of Leeds, in the midst of modern manufacturing establishments. Next after Fountains Abbey, it is the best-preserved monastic ruin in the county. First founded at Barnoldswick in the same neighbourhood in 1147, but five years later moved to its present site, the abbey is mainly Transition Norman and Perpendicular in style. The church is, like most Cistercian churches, long and narrow, with little ornamentation, and a low tower. The abbey was presented to the town by Colonel North in 1889.

Kirkwall, the capital of Orkney, on the east coast of Mainland, 49 miles NE. of Thurso, and 225 N. of Leith. St Magnus' Cathedral (1137-1500) is a stately cruciform pile, mixed Norman and Gothic in style. It measures 253 feet by 102 across the transept, and has a central tower 133 feet high. The choir serves as a parish church. The last vestige of the royal castle was demolished in 1865; but the roofless Earl's Palace (1607) remains, and a tower (1550) of the Bishop's Palace, in which King Haaco died in 1263. In 1876-79, £10,500 was expended on drainage, paving, and water-supply; and the harbour, with an iron pier of 1866, has also been much improved. Made a royal burgh in 1486, Kirkwall unites with Wick, &c., to return one member to parliament. Pop. (1841) 3041; (1891) 3926. See Tudor's *Orkneys and Shetlands* (1883).

Kirriemuir, a small town of Forfarshire, 8½ miles NW. of Forfar by rail, with some linen weaving. It is the birthplace of J. M. Barrie, and the 'Thrunis' of his stories. Pop. (1891) 4179.

Kirschwasser (Ger., 'cherry water') is a liqueur made from cherries, and highly esteemed in Germany. The cherries, gathered when quite ripe, and freed from their stalks, are pounded in a wooden vessel, but so that the stones are not broken. They are then left to ferment, and when fermentation has begun the mass is stirred two or three times a day. The stones are afterwards broken, and the kernels bruised and thrown in. By distillation kirschwasser is obtained. For cherry-brandy, see BRANDY.

Kisfaludy, SANDOR (ALEXANDER), a Hungarian poet, was born at Sümeg, in the county of Zala, on 22d September 1772. He served in the Austrian army from 1793 to 1801, and again in

1809. The rest of his life was devoted to literature and farming. He established his fame by a collection of lyrics—his best work—entitled *Himfy's Loves* (1801-7), which created extraordinary enthusiasm; and his fame was further enhanced by *Legends of the Olden Time in Hungary* (1807; 2d ed. 1812). Kisfaludy also attempted the drama, but less successfully; his best dramas are *Johu Hangadi* and *Ladishans the Comedian*. He was one of the founders of the Hungarian Academy of Sciences, which has rendered inestimable service in the advancement of the literary and intellectual life of Hungary. He died at Simeg, 30th October 1844. His *Collected Works* appeared in 6 vols. in 1847, to which 4 vols. of *Posthumous Writings* were added in 1870.

KAROLY (CHARLES) KISFALUDY, younger brother of the preceding, and regenerator of the national drama of Hungary, was born at Tet, in the county of Gyor (Raab), on 6th February 1788. By quitting the army in 1811 he incurred the anger of an austere father, and was obliged to earn a precarious livelihood as an amateur artist, until in 1819 the success of a drama, *The Tartars in Hungary*, made him suddenly famous. This was followed by several others, all dealing with the past history of his country, and by comedies based upon popular life, the best of them *The Student Matthous*. Kisfaludy steadily improved as a dramatist as years went on. He died at Pesth, 21st November 1830. His *Collected Works* were published in 10 volumes in 1831 (5th ed. 8 vols. 1859).—The *Kisfaludy Society*, established in honour of the brothers in 1837, has rendered important services to Hungarian literature.

Kishineff, capital of the Russian government of Bessarabia, stands on a tributary of the Dniester, 162 miles NW. of Odessa by the railway to Jassy. When it came into the possession of Russia in 1812 it was a place of only 7000 inhabitants; since then, however, it has rapidly increased in size and prosperity. The old or lower town abuts upon the river; the new town stands on cliffs between 400 and 500 feet above the river. Pop. (1832) 35,000; (1849) 42,613; (1871) 102,427; (1897) 108,506, composed of nearly all the surrounding nationalities. Fruit, the vine, and tobacco are grown; and tobacco and flour are manufactured. Kishineff is an important trading centre for Bessarabian native products. It is the seat of an archbishop, and has a theological seminary.

Kishm, or **PAWLDAH** (the ancient *Characta*), a parched and barren island of Persia, situated at the entrance to the Persian Gulf. It is 55 miles long, and has an area of 515 sq. m. Salt and sulphur, and the food-products of a few oases, are all that the island yields. Pop. 5000. The island was visited by a severe earthquake in 1881, twelve villages being destroyed and some two hundred lives lost.

Kismet. See FATE, MOHAMMEDANISM.

Kiss, a familiar form of salutation by touching with the lips as an expression of respect or affection, in earlier times and still in many countries used in the common intercourse of man with man, but mostly limited by modern Englishmen to the domestic and dearer relationships of life. The *osculum* was a formal symbol of goodwill among the ancient Romans, and was adopted by the early Christians, whose 'holy kiss' and 'kiss of charity' carried the weight of apostolic sanction. The 'kiss of peace' at the mass, in the Eastern Church and the Mozarabic and Ambrosian liturgies, is given before the offertory and consecration; but in the Roman mass it follows the consecration and is closely connected with the communion. About the end of the 13th century the kiss of peace in the

West gave way to the *osculatorium*, called also the *instrumatum* or *tabella pacis, pacis, pacificale*, or *freda*, a plate with a figure of Christ on the cross stamped on it, kissed first by the priest, then by the clerics and congregation. The kiss of peace was given also at baptism, and is still given by the other bishops to a bishop newly consecrated, and by the bishop to a priest at his ordination; and the Greeks still preserve the rite of giving the kiss of peace to the dead.

The Christians early adopted the practice of kissing the altar as a mark of reverence to the place on which the eucharist is offered, and the officiating priest still does so repeatedly in the Roman mass. It is usual also to kiss the golden cross of the sandal on the pope's right foot on his appointment to office, by newly-created cardinals and by persons on being granted an audience. Even royal persons in former times paid this act of homage to the Vicar of Christ; it is said that Charles V. was the last that did so.

See Kahle, *De Osculo Sancto* (Konigsberg, 1867); Valentini, *De Osculatione Pedum Romanæ Pontificis* (Rome, 1588); and Pougard, *Del Bacio de' Piedi de' Sommi Pontifici* (Rome, 1807).

Kissingen, the most popular watering-place in Bavaria, is situated on the Saale, 60 miles E. by N. from Frankfort-on-Main. Of its three mineral springs (temperature 50.7-51.2° F.), the Rakoczy and the Pandur furnish saline and chalybeate waters, while the Maxbrunnen is acidulous and saline. The Solen-Sprudel is remarkable for the periodical ebb and flow of its waters, caused apparently by the accumulation and discharge of carbonic acid gas. Besides these there are two other springs near the town, and in the same valley the spas of Boeklet and Brückenau. The waters of Kissingen are both drunk and used as baths by the patients, and are considered specially efficacious in cases of dyspepsia, skin diseases, affections of the bowels, eyes, and ears, gout, &c. The population (4024) is increased by an influx of 13,000 to 14,000 visitors annually. Although the existence of mineral (saline) springs at this spot was known as early as the 9th century, it was not until the 16th that their medical properties were recognised, and not until the 19th that the springs came to be in great repute. Between 500,000 and 600,000 bottles of the Kissingen waters are exported annually. At Kissingen an attempt was made to assassinate Prince Bismarck, by Kullmann, on 13th July 1874. See guides, all in German, by Sotier (2d ed. 1883), Werner (3d ed. 1883), Dirri (5th ed. 1884), and Ising (3d ed. 1885).

Kistna, or **KRISHNA**, a river of southern India, rises in the Western Ghats within 40 miles of the Arabian Sea, at a height of 4500 feet, in 18° 4' N. lat., and, flowing eastward across the peninsula, falls into the Bay of Bengal after a course of 800 miles. Area of drainage basin, 97,050 sq. m. The river forms for a considerable distance the boundary between the Nizam's dominions and Madras Presidency, and has a delta extending 100 miles inland. It is only navigable for about 50 miles during six months of the year.

Kistvaen, or **CIST**. See BARROW, BERAL.

Kit-Cat Club, a society formed in London about 1700, consisting of thirty-nine noblemen and gentlemen favourable to the succession of the House of Hanover, and whose ostensible object was the encouragement of literature and the fine arts. Jacob Tonson, an eminent publisher, was founder and secretary; and, not to mention dukes and earls, it included Sir Robert Walpole, Vanbrugh, Congreve, Addison, Steele, and Garth. The club derived its name from having met for some time in the house of Christopher Catt, a pastrycook.

Before its dissolution (about 1720) each of the members gave Tonson his half-length portrait, painted a uniform size, by Kneller. Hence a kit-eat is any portrait of that size—about 36 in. by 28.

Kitchener, HERBERT, LORD, of Khartoum and Aspell in Suffolk, born 22d September 1850 at Gunsborough Villa, near Ballylongford, Kerry, studied at Woolwich Academy, and entered the Engineers in 1871. On the Palestine survey 1874-78, and then on that of Cyprus till 1882, he commanded the Egyptian cavalry 1882-84, served in the Soudan campaign 1883-85, was governor of Suakin 1886-88, and Sirdar of the Egyptian army from 1890. As such, he recovered Dongola (1896), defeated the dervishes at the Atbara (April 1898), and by the final victory of Omdurman, 2d Sept. 1898, routed the Khalifa, and won back the Soudan for Egypt. He was raised to the peerage, having four years before been created a K.C.M.G. In 1899 he went with Lord Roberts to South Africa as chief of the staff in the Transvaal War, and in November 1900 he assumed chief command with the rank of lieutenant-general. See G. W. Steevens's *With Kitchener to Khartoum* (1898).

Kitchen-midden (Dan. *kjøkken-mødding*), mounds in Denmark, N. Scotland, &c., prehistoric refuse-heaps. They are mostly formed of oyster-shells and other shellfish; contain only stone, bone, or wood implements; and bones of the dog and wild animals. See ANTHROPOLOGY, MAN, STONE AGE.

Kite, one of the long-winged, small-footed, short-beaked Falconidae. The typical genus is *Milvus*, confined to the Old World, and represented by half-a-dozen species. Of these the Common or Red Kite (*Milvus tetras*), found throughout Europe, is now very rare in Britain. It feeds on

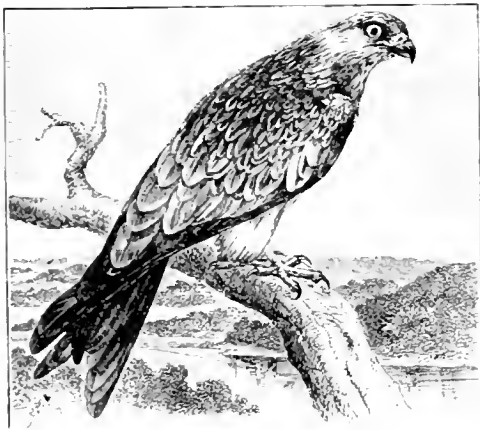

Common Kite or Glead (*Milvus tetras*).

ollal and small vertebrates of all kinds, and may be destructive to young game and poultry. The Black Kite (*M. nigrescens*) has been recorded in Britain; the Pariah Kite (*M. gangeticus*) of India is a useful scavenger; *M. isurus* inhabits Australia. Under the title kite are also included the Black-winged Kites (*Elanus*) of both hemispheres; the beautiful Swallow-tailed Kite (*Elanoides forficatus*), occurring in the warmer parts of North America; the Hook-billed Kite (*Rostrhamus*) of South America and Florida, feeding, curiously enough, on fresh water snails; and the large Bee-kite or Honey Buzzard (*Percnias apicivorus*), inhabiting Europe and Africa.

Kits Coty House, the best known dolmen in England, stands on a hillside near the road from Rochester to Maidstone, 1½ mile NW. of

Ayleston. Three upright blocks of sandstone 8 feet high support a 'covering stone' 12 feet long so as to form a chamber. The name is supposed to be from old British words for 'the tomb in the wood' (cf. Welsh *coed*, 'wood'). See DOLMEN.

Kittiwake. See GULL.

Kitto, JOHN, an industrious and praiseworthy writer on biblical subjects, was born at Plymouth, December 4, 1804. In his twelfth year he lost his power of hearing in consequence of a fall from a height of 35 feet. His father's circumstances were at this time so wretched that young Kitto was soon after sent to the workhouse, where he learned the trade of shoemaking. In 1824 he went to Exeter to learn dentistry with a Mr Grove, who encouraged him in his literary aspirations; and in 1825 he published *Essays and Letters by John Kitto*. In the same year he was sent to the Missionary College at Islington, where he learned printing. In 1829-33 he accompanied Mr Grove and family on a tour to the East, visiting in the course of his travels St Petersburg, Astrakhan, the Caucasus, Armenia, and Persia. The rest of his life was spent in the service of the publishers, chiefly in that of Charles Knight, whose failure led to less constant employment and pecuniary embarrassments. In 1850 he received a civil list pension of £100 a year. Stricken with paralysis, he died at Cannstadt, in Württemberg, November 25, 1854. His principal works are *The Pictorial Bible* (1838; new ed. 1855), *Pictorial History of Palestine* (1839-40), *History of Palestine* (1843), *The Lost Scenes, Deafness and Blindness* (1845), *Journal of Sacred Literature* (1848-53), and *Daily Bible Illustrations* (1849-53; new ed. by Dr Porter, 8 vols. 1867). He also edited the *Journal of Sacred Literature* (1848-53). In 1844 the university of Giessen conferred on him the title of D.D. Kitto had a working knowledge of Hebrew, Greek, Latin, and the modern tongues. See his Life by Eadie (1857) and Ryland (1856).

Kiu-kiang, or CHIÜ-CHIANG, a Chinese treaty port on the Yang-tze-kiang. Pop. 53,000.

Kiung-chow, chief city of Hainan (q.v.).

Kiwi. See PTERYX.

Kizil-bashes, Persianised Turks. See AFGHANISTAN, KHIVA.

Kizil-Irmak. See ASIA MINOR.

Kizil-Kum (meaning 'Red Sands'), a sandy desert in Russian Turkestan, lying between the lower courses of the Amu-Daria and Syr-Daria. They stretch south-east from the Sea of Aral, and rise from an elevation of 150 feet at the sea to 2000 towards Bokhara. They are partly of shifting nature and partly stationary, and are diversified by numerous undulations or ridges of sand, between which extensive patches of clay occur. North-east of the Caspian stretches the Kara-Kum ('Black Sands') desert, a former bed of the sea.

Kjernf, HALDAN, composer, was born at Christiania, 15th September 1815, and studied law, but devoted himself to music. He wrote much for the piano, but is best known for his charming songs, full of melody and true Norwegian feeling. He died 11th August 1868. There is an English album of his songs, the translations by Mazzioli (1883).

Kjöbenhavn. See COPENHAGEN.

Klagenfurt, the capital (since 1518) of the duchy of Carinthia, in Austria, on the Glan, 262 miles SW. of Vienna by rail. The palace of the Prince-bishop of Gurk possesses a noteworthy chapel; and in the town there are schools of mining, agriculture, technical arts, &c., a library of 35,000 vols., and the Rudolfinum museum. Klagenfurt has

a large white-lead factory, and manufactures leather, cast-iron, tobacco, &c. An active transit trade is carried on. Pop. (1890) 19,756. The fortifications were dismantled by the French in 1809, and now, converted into promenades, separate the town from its four suburbs.

Klapka. GEORGE, one of the most heroic and skilful generals of the Hungarian war, was born at Temesvar on 7th April 1820. He rose to the rank of lieutenant-general in the Austrian army, but on the outbreak of the revolution placed himself at the service of the Hungarian government, and took a prominent part in nearly all the battles against the Austrians between February and August; in more than one the fortune of the day was decided by the troops under his command. But the crowning glory of his career was his defence of Komorn, which he continued to hold for some weeks after all the rest of Hungary had submitted. He lived in exile until the amnesty of 1867 let him return; and he died 17th May 1892. He wrote *The National War in Hungary and Transylvania* (1851), one of the best works on the subject; *The War in the East* (1855); and two series of *Memoirs* (1850 and 1886).

Klaproth. HEINRICH JULIUS VON, orientalist, was born at Berlin, 11th October 1783, the son of Professor Martin Heinrich Klaproth (1743-1817), chemist and mineralogist. At fourteen undertaking the study of Chinese, in 1805 he was appointed interpreter to a Russian embassy to China. It was stopped on the frontier, when Klaproth took the opportunity of exploring Siberia, as afterwards (in 1807-8) the Caucasus and Georgia. Returning to Germany in 1812, he settled three years later in Paris, where in 1816 he was appointed professor of Asiatic Languages, and where he died, 20th August 1835. From 1802 onwards he published innumerable works, in German and later in French, on the subject of his travels, of Asiatic philology and ethnology, of Egyptian hieroglyphics, &c. A blot on their erudition and acuteness is his virulent assaults on other scholars. His *Erfundung des Kompass* was edited by Wittstein in 1885.

Klausenburg (Hungarian *Kolozsvár*), one of the chief cities in Transylvania, is situated 95 miles by rail E. by S. from Grosswardein. It consists of the inner town, formerly fortified, and of five suburbs. Here are a university, with four faculties (founded in 1872), and a Unitarian College, both with libraries, an observatory, a music school, and numerous other educational establishments. The town possesses the national museum, with antiquities, scientific collections, and a library of 45,000 vols. Klausenburg was captured by the Hungarians under Bem on Christmas Day 1848. Machines, oil, and spirits are manufactured. Pop. (1880) 29,921; (1890) 32,729.

Klausthal, the chief mining-town of the northern Harz Mountains, stands on a bleak plateau (1985 feet), 25 miles N.E. of Göttingen. The ores raised are silver, lead, copper, and zinc. There is a good mining academy, with library, museum, and laboratory. Zellerfeld, divided from Klausthal by a brook, is also a mining centre. The mines are the property of the Prussian government. Pop. 8871; but including Zellerfeld, 13,278. The men are almost exclusively employed in the mines and smelting work.

Kleber. JEAN BAPTISTE, a distinguished French soldier, born in March 1753 at Strasburg, where his father was a builder. He was destined for an architect, but his opportune assistance in a Paris tavern brawl to two young German nobles obtained him a nomination to the military school of Munich, and afterwards a commission in the Austrian army. This, however, he resigned after

a few years, and returned to France to become inspector of public buildings at Belfort. In 1792 he enlisted in the Haut-Rhin volunteers, and rapidly rose in rank, becoming general of brigade in 1793. As such he commanded in the Vendean war, but was recalled for advocating more lenient measures. Next year, as general of division in the northern army under Jourdan, he led the left wing at Fleurus, and captured Maestricht; and in June 1796 he gained the brilliant victory of Altenkirchen over the Prince of Würtemberg. He accompanied Bonaparte to Egypt as a general of division, was dangerously wounded at the capture of Alexandria, but recovered so as to take part in the expedition to Syria, and won the battle of Mount Tabor (1799). When Bonaparte left Egypt he entrusted the chief command there to Kleber, who concluded a convention with Commodore Sidney Smith for its evacuation; but on Admiral Keith's refusal to ratify this convention Kleber adopted the bold resolution of reconquering Egypt, and destroyed the Turkish army at Heliopolis. During an attempt to conclude a treaty with the Turks Kleber was assassinated by a Turkish fanatic at Cairo, 14th June 1800. There are Lives by Einouf (1867) and Pajol (1877).

Kleene-bok. See ANTELOPE.

Kleist. EWALD CHRISTIAN VON, German poet, was born at Zeblin, near Köslin in Pomerania, on 7th March 1715. In 1749 Frederick the Great induced him to enter the Prussian army; he was severely wounded whilst leading an attack on a hostile battery at the battle of Kunersdorf, and died twelve days later (24th August 1759) at Frankfort-on-the-Oder. The lyric poet Gleim first taught him how to develop his poetic talents. His name is best known from his *Poems*, especially the one entitled *Frühling*, a sort of descriptive lyric. Besides this he wrote tales (*Die Freundschaft* and *Arist*), idylls (*Irin*, &c.), fables, and hymns. The latest edition of his *Works* was issued by A. Sauer (1884). See Life by Einbeck (1861).

Kleist. HEINRICH VON, German dramatist and poet, was born at Frankfort-on-the-Oder, on 18th October 1777. At first he followed the family profession and entered the army; but left it in 1799 to study, yet science he soon abandoned for literature. As a writer his aims and desires outran his ability to execute, and his works are marred by want of clearness and artistic completeness; in fact, he has some of the worst faults of the Romantic school, to which he belongs. Nevertheless, his best plays, such as *Der Prinz von Homburg*, *Das Käthchen von Heilbrunn*, *Hermanns-schlacht*, and *Der zerbrochene Krug*, possess sufficient vigour and fidelity to life to make them popular even at the present day. The best of his tales is *Michael Kohlhaas*, a story of Brandenburg in the middle ages. The morbid tendencies in his character made him quit before the adversities against which he had to battle, and at last brought him to a suicide's grave. He shot himself, after first shooting a woman whom he loved, and who like him was weary of life, on the bank of Lake Wann near Potsdam, 21st November 1811. His works did not gain recognition until after his death; they were first made known by Tieck, who in 1826 published Kleist's *Gesammelte Schriften* (3 vols.; new ed. 1874). See Life by Brahm (1884).

Klepts. Greek brigands. See BRIGANDS.

Kleptomania (Gr. *klepto*, 'I steal'). Among the phenomena of certain minds that are not regarded as technically insane or criminal are observed inordinate tendencies to acquire, to collect, and to hoard. All young children desire and will at once appropriate whatever they fancy. So long as

property of others, or involve a flagrant breach of law, they are readily admitted as an indication of disease, or as an absurdity and eccentricity which may help to consign the individual to an asylum or to contempt, but concern no one else. But whenever the amount of the object appropriated, or the circumstances under which it is purloined, bring the matter into a court of law, the act is treated as a theft. Such conduct is often the result of disease; it is rarely a disease by itself. The inclination to steal is a premonitory indication of some forms of mental disorder: it is a characteristic symptom of many others, where violence, or delusion, or incoherence leaves no doubt as to the source from which it springs. But there are other cases in which the morbid origin cannot be so clearly demonstrated—where the mind is clear and cogent, the morals pure, and where theft is almost the only proof of insanity. There is evidence in favour of the opinion that the propensity to steal may become so irresistible, and the will so impotent, that the appropriation is involuntary, and the perpetrator irresponsible. It then forms one of the varieties of insanity (see the article INSANITY) characterised by defective inhibition. The gratification of the impulse is commonly found associated with physical changes and conditions which may be regarded as incompatible with the healthy discharge of the functions of the nervous system; but that connection is not invariable, and the best mode of establishing the reality of such a disease is to consider marked cases in relation to the character, interests, and previous deportment of the individual, to the nature of the articles taken, and to the motives. A baronet of large fortune stole, while on the Continent, pieces of old iron and of broken crockery. A clergyman of great usefulness abstracted from book-shops and stalls hundreds of copies of the Bible. The objects are often stolen ostentatiously, or without any adequate precautions to conceal the attempt; they are often of no value; the act is without motive, promptly and spontaneously avowed, and, if overlooked, repeated. The article acquired is restored, or disregarded; and although money is rarely taken, bright and coloured objects most generally excite cupidity.

See Bucknill and Tuke, *Psychological Medicine* (1853); Clouston, *Mental Diseases* (2d ed. 1887).

Klondike, or **KLONDYKE**, a small tributary of the Yukon river in the Canadian district of Yukon, separated from the North-West Territories in 1895. The Klondike (properly *Thron-duick*, 'plenty of fish') gives name to an extraordinarily rich auriferous region, partially known as early as 1873. Gold-mining was being carried on on the Lewis and Stewart rivers in the early eighties, but only in 1896 was gold found on the Klondike in such abundance as to cause the desertion of the adjoining diggings and to create a rush from Europe, renewed in 1897 and 1898. Dawson, where the Klondike enters the Yukon river, is 60 miles east of the Alaskan (U.S.) frontier.

Klopstock, **FRIEDRICH GOTTLIEB**, was born 21 July 1724, at Quedlinburg. Incited by Virgil's *Æneid* and Milton's *Paradise Lost*, he resolved to write a great epic poem whilst a theological student at Jena (1745), selected for his theme *The Messiah*, and while at Leipzig got the first three cantos published in a Bremen magazine (1748). They were received with enthusiasm, except by Gottsched, who denounced his language and verse-structure as heretical innovations. He settled in Hamburg in 1771 with a sinecure appointment, and pensions from the king of Denmark (since 1751) and the margrave of Baden. In 1773 the last cantos of *The Messiah* were published; the poet

died 14th March 1803. His name has (or rather had) a very high place in German literature. For instance, he was taken by the Göttinger Dichterbund as their model and poetic hero, and was greatly admired by young Schiller. Whatever may be thought of the intrinsic value of his poetry, it cannot be denied that he helped to inaugurate the golden age of German literature, and exercised a very beneficial influence on the national taste. When he first began to write, the literature of Germany was dominated by French influences—a cold, correct, unimaginative spirit. Klopstock broke loose from this despotism and breathed the air of freedom into German poetry. Odes, tragedies—in which he introduces Arminius as a national hero—and biblical dramas, with some hymns, constitute the remainder of his poetry. Of these his *Odes* alone possess interest and value now. His works were collected and published in 12 vols. (1798–1817), and in 9 vols. (1839). *The Messiah* has been translated into both English verse and prose. See Life by Muncker (1887–88).

Kluhevskaya. See KAMCHATKA.

Knapweed. See CENTAURIA.

Knaresborough, a market-town in the West Riding of Yorkshire, on the Nidd, 3½ miles N.E. of Harrogate and 17 W.N.W. of York. It has a church (restored 1872), with interesting monuments of the Slingsbys; a grammar-school (1616); remains of a castle (1170), in which Richard II. was imprisoned, and which was dismantled in 1648; a 'dropping well,' with petrifying properties; and St Robert's Cave, in which Eugene Aram buried his victim in 1745. Mother Shipton is claimed as a native, and Jack Metcalf, the blind road-surveyor. Linen and woollen rugs are the staple manufactures. Knaresborough returned two members from 1550 till 1867, and one until 1885. Pop. (1851) 55,6; (1881) 5000; (1891) 4770. See works by Calvert (1844) and Grainge (1871).

Knee, the articulation between the femur or thigh-bone, above, and the tibia or shin-bone, below. A third bone, the patella, or knee-cap, also enters into the structure of this joint anteriorly. The articular surfaces of these bones are covered with cartilage, and connected together by ligaments, some of which invest the joint and lie external to it, while others occupy its interior. The synovial membrane is the largest in the body.

It lines the investing ligament, and is prolonged on the front of the femur above the articular surface, covers certain of the ligaments in the interior of the joint, and forms folds on a large cushion of fat placed between the tibia and patella.

The most important of the external ligaments are the anterior or *Ligamentum Patellæ*, which is in reality that portion of the *Quadriceps Extensor Cruris* which is continued from the knee-cap to the tubercle of the tibia; one internal and two external lateral ligaments; a posterior ligament; and a capsular ligament, which surrounds the joint in the

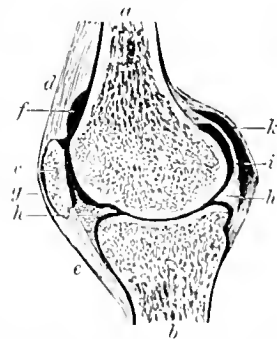

Vertical Sagittal Section through the inner half of the Left Knee (from Macalister):

a, femur; b, tibia; c, patella; d, tendon of quadriceps muscle; e, ligamentum patellæ; f, subserous bursa; g, prepatellar bursa; h, internal semilunar cartilage; i, ligamentum posticum; k, inner head of gastrocnemius.

intervals left by the preceding ligaments. The positions of these ligaments are sufficiently indicated by their names. Of the internal ligaments the two crucial, so called because they cross one another, are the most important. The external and internal semilunar cartilages are usually placed amongst the internal ligaments; they are two crescentic plates of fibro-cartilage. The convex border of each cartilage is thick; the concave free border is thin. Each cartilage covers nearly the marginal two-thirds of the corresponding articular surface of the tibia, and by its form deepens these surfaces for firmer articulation with the condyles of the femur.

The chief movements of this joint are those of a hinge-joint—namely, flexion and extension; but it is also capable of slight rotatory motion when the knee is half-flexed. During flexion the articular surfaces of the tibia glide backwards upon the condyles of the femur; while in extension they glide forwards. The whole range of motion of this joint, from extreme flexion to extreme extension, is about 135°. Judging from its articular surfaces, which have comparatively little adaptation for each other, it might be inferred that this was a weak and insecure joint; and yet it is very rarely dislocated. Its real strength depends on the large size of the articular ends of the bones, on the number and strength of the ligaments, and on the powerful muscles and fasciæ by which it is invested. See JOINTS, where also the exsion of the knee-joint is discussed.

The KNEE-CAP, or PATELLA, is a Sesamoid Bone (q.v.), developed in the single tendon of the *rectus, curvus, vastus externus, and vastus internus* muscles—the great quadriceps extensor muscle of the leg. It is heart-shaped in form, the broad end being directed upwards, and the apex downwards. The anterior or external surface is convex, perforated by small apertures for the entrance of vessels, and marked by rough longitudinal striae; the posterior or internal surface is smooth and divided into two facets by a vertical ridge, which corresponds and fits into the groove on the lower articulating surface of the femur or thigh-bone, while the two facets (of which the outer is the broader and deeper) correspond to the articular surface of the two condyles.

This bone is liable both to dislocation and fracture. Dislocation may occur either inwards or outwards; but it is most frequent in the outward direction. The displacement may be caused either by mechanical violence, or by too sudden contraction of the extensor muscles in whose conjoined tendon it lies; and is most liable to occur in knock-kneed, halby persons. Except in one rare variety, the dislocation is capable of being reduced without any difficulty. Fracture of the patella may, like dislocation, be caused either by muscular action or by mechanical violence.

Fracture by violent muscular action, as when a person in danger of falling forwards attempts to recover himself by throwing the body backwards, is the more common of the two forms. The treatment consists in relaxing the opposing muscles by raising the trunk, and slightly elevating the limb, which should be kept in a straight position. In consequence of the great difficulty of bringing the broken surfaces into exact apposition it is very difficult to obtain bony reunion of the parts, and the case generally results either in mere ligamentous union or in no true union at all.

Kneeling was probably the general posture of the early Christians in prayer not regulated by public authority, but the early church made no distinction in language between kneeling and prostration. At communion the first prayer was said kneeling, the rest of the liturgy standing. At other times of service the rule was for all to kneel

in prayer except on Sundays and between Easter and Whitsuntide. In the modern Catholic Church kneeling is the usual attitude at prayer, as in the Church of England. In the Roman and Greek churches, and with some Anglicans, the celebrant, after kneeling in adoration, communicates standing. In the Church of England, and in the Lutheran Church, the sacrament is received kneeling; Lutherans stand at prayer. Presbyterians sit when receiving the communion, and were till lately accustomed to stand at prayer; recently kneeling at prayer has become the usual practice, save in the remoter districts of Scotland.

Kneller, SIR GODFREY, a portrait-painter, was born at Lubek on 8th August 1646, and learned painting under Rembrandt and Ferdinand Bol. Whilst studying further in Italy he chose historical subjects, but afterwards gave himself entirely to portrait painting. In 1676 he went to London, and, on the death of Sir Peter Lely in 1680, was appointed court-painter to Charles II. This office he retained during the reign of James II., and continued to fill it after the Revolution. In 1691 William III. knighted him, and in 1715 George I. made him a baronet. He died at Twickenham, 7th November 1723, and a monument was erected to him in Westminster Abbey, with a highly laudatory inscription by Pope. Kneller's best-known productions are the 'Beauties of Hampton Court' (painted by order of William III.), his portraits of the 'Kit-Cat Club,' and of nine sovereigns (Charles II. to George I. of England, Louis XIV., Peter the Great, and the Emperor Charles VI.). He painted avowedly for the love of money, and hence never did justice to the undoubted talent he possessed. His reputation was due to his rapid brush and his quick eye for likeness, and to the fact that there was nobody to dispute supremacy with him. For Kneller Hall, his house at Twickenham, see BAND (MILITARY).

Knickerbocker, HERMAN JANSSEN, of Friesland, Holland, was one of the earliest settlers of New York. A descendant, Johannes (1749-1827), was an intimate friend of Washington Irving, who immortalised the name by his *History of New York* by 'Diedrich Knickerbocker' (1809). It has since been used as a generic term for New York families descended from the original Dutch settlers.

Knight, CHARLES, author and publisher, was born in 1791. The son of a Windsor bookseller, in 1811 with his father he established the *Windsor and Eton Express*, and continued to edit it until 1821, at the same time printing the *Etonian*. The *Plain Englishman* (1820-22), which was the first attempt to produce cheap literature of a high tone, was jointly edited by Charles Knight and Commissioner Locket of Greenwich Hospital. Removing to London in 1822, Knight began to publish important works in various classes of literature, and he also founded *Knight's Quarterly Magazine*, to which Macaulay, Præd, Montrie, and other writers of promise contributed. In 1827 he became connected with the Society for the Diffusion of Useful Knowledge, for which he published many valuable works and serials, including the *Penny Magazine* (1832-45), which attained a circulation of 200,000 copies weekly. Knight began to issue in 1838 the *Penny Cyclopædia*, upon which he expended for contributions alone the sum of £40,000. This was followed by the *English Cyclopædia* (1851-61), the *British Almanac*, and its *Companion*. Knight edited the *Pictorial Shakespeare*, and was the author of *William Shakespeare: a Biography*. He likewise issued *The Land We Live In* and other works. In 1853 Knight published *Once Upon a Time*, which consisted of a collection of papers from the periodicals; and in 1855 *Knowledge is Power*, a work based upon two

smaller volumes—*Results of Machinery* and *Rights of Industry*—which secured a large sale at a time when the improvements in machinery excited a hostile feeling and the relations between capital and labour were considerably strained. In 1862 Knight completed his *Popular History of England*, upon which he had been engaged for seven years. His *Passages of a Working Life during Half a Century*, which appeared in 1863-65, recounted the struggles of his own life as well as gave interesting pictures of the numerous literary and political personages with whom he had been associated. Knight's compilations, *Half-hours with the Best Authors*, *Half-hours of English History*, and *Half-hours with the Best Letter-writers*, have become widely popular. By his appointment in 1860 as publisher of the *London Gazette* £1200 per annum was assured to him. He died at Addlestone, Surrey, 9th March 1873. (See Life by goldingher (1892).)

Knighthood. The word 'knight' is the modern equivalent of the Anglo-Saxon *enicht*, which meant originally a youth, and afterwards a servant or attendant, and soon came to be restricted to the military attendants upon nobles and great officers of state. This personal relation was subsequently strengthened by the feudal relation of tenancy, in virtue of which the knight held land of his superior under condition of rendering him military service in return (see FEE-DALISM). The origin of medieval knighthood, as a solemn investiture and profession of arms, is involved in obscurity. Embryonic forms of the institution can be traced amongst the early Teutonic nations, and especially the Franks. The customs of chivalry associated with King Arthur and Charlemagne's paladins are of course those of a later era, the epoch of the romance writers. The custom and practice of knighthood were established in England, but as an essentially feudal institution, by the Norman kings. The system of knight-service empowered the king, or a superior lord who was a subject, to compel every holder of a certain extent of land, called a knight's fee, to become a member of the knightly order, his investiture being accounted proof that he possessed the requisite knightly arms and was sufficiently trained in their use. After the long war between France and England it became the practice for the sovereign to receive money compensations from subjects who were unwilling to receive knighthood, a system out of which grew a series of grievances, leading eventually to the total abolition of knight-service in the reign of Charles II.

The ceremonies practised in conferring knighthood have varied at different periods; but two broadly marked ceremonial forms may be recognised, the simple dubbing and the formal investiture as a semi-religious ceremony. In general, in the more elaborate ceremony, fasting and bathing were necessary preparatives, and the actual creation was preceded by solemn confession and a midnight vigil in the church, followed by the reception of the eucharist. The new knight offered his sword on the altar, to signify his devotion to the church and determination to lead a holy life. The sword was redeemed by a sum of money, had a benediction pronounced over it, and was girded on by the highest ecclesiastical present. The title was conferred by binding the sword and spurs on the candidate, after which the person who conferred the order dealt him a blow on the cheek or shoulder, saying, 'Be thou a good and faithful knight,' or words to that effect. The new knight then took an oath to protect the distressed, to maintain right against might, and never by word or deed to stain his character as a knight and a Christian. The religious character of the ceremony seems to have become thus prominent in and after the foundation

of the militant monastic orders in Palestine, as the Knights Templars (see TEMPLARS) and Knights of St John (see HOSPITALIERS). A knight might be degraded for the infringement of any part of his oath, in which case his spurs were chopped off with a hatchet, his sword broken, his escutcheon reversed, and some religious observances were added, during which each piece of armour was taken off in succession, and cast from the recipient knight. This ceremony was of very rare occurrence, but was performed in effigy as late as 1814 in the case of Lord Dundonald (q.v.).

'Knights errant' were they who wandered seeking foemen worthy of their steel, and acquiring fame at joust and tourney, by maintaining the pre-eminence in beauty and virtue of the ladies to whom they had vowed service. The (unhistorical) 'Knights of the Round Table' (see ARTHUR) and the paladins of Charlemagne (see ROLAND) are types of those whose mission it was to succour distressed damsels and destroy tyrants; and Amadis (q.v.) may be taken as a representative hero of those romances of chivalry which Cervantes satirised in *Don Quixote*. Sad specimens of the military knights in a degraded condition were the robber knights (*Lombardes*) of Germany, who lived largely by levying blackmail on merchants or by sheer plunder.

Knighthood, originally a military distinction, came, in the 16th century, to be occasionally conferred on civilians, as a reward for valuable services rendered to the crown or community. The first civil knight in England was Sir William Walsworth, lord mayor of London, who won that distinction by slaying the rebel Wat Tyler in presence of the king. Since the abolition of knight-service knighthood has been conferred without any regard to property, as a mark of the sovereign's esteem, or as a reward for services of any kind, civil or military. In recent times it has been bestowed at least as often on administrative officials, scholars, lawyers, physicians, artists, and citizens as on soldiers. Although knighthood could originally be conferred by any person of knightly condition, the right to bestow it was early restricted to persons of rank, and afterwards to the sovereign or his representative, as the commander of an army. In England the sovereign now bestows knighthood by a verbal declaration, accompanied with a simple ceremony of imposition of the sword, and without any patent or written instrument (see ACCOLADE). In some few instances knighthood has been conferred by patent, when the persons knighted could not conveniently come into the presence of royalty, as in the case of governors of colonies, or other persons occupying prominent situations abroad. The lord-lieutenant of Ireland also occasionally, but rarely, exercises a delegated power of conferring knighthood. The monosyllable 'Sir' is prefixed to the Christian names of knights and baronets, and their wives have the legal designation of 'Dame,' which in common intercourse becomes 'Lady.' For the existing orders of knighthood, see ORDERS, BATH, GARTER, THISTLE, GOLDEN FLEECE, &c.

Persons who are simply knights, without belonging to any order, are called in England Knights Bachelors. Knighthood of this kind is now only conferred in Great Britain. A degree of knighthood called Banneret (q.v.) formerly existed in England and France; it was given on the field of battle in reward for the performance of some heroic act. It is noticeable that, whereas the German word for knight is *Ritter*, the word *knecht*, etymologically the same as knight, means the squire or a still humbler attendant of the knight. The French knight (see LÉGITIM OR HONORÉ) is *chevalier*, the Italian *cavaliere*. The form of helmet which the requirements of the later heraldry have appropri-

ated to knights is figured under HERALDRY (fig. xi.). For Knights of the Shire, see PARLIAMENT.

See Gross, *Military Antiquities*; Stubbs, *Constitutional History*; Nicolas, *British Orders of Knighthood*; Hallam, *Europe during the Middle Ages*; C. Mills, *History of Chivalry* (1825); Gantier, *La Chevalerie* (1884); Reibisch, *Geschichte des Ritterthums* (1842); Schreckenstem, *Die Ritterorden* (1884); Major Lawrence-Archer's *Orders of Chivalry* (1888).

Knight-service. See TENURE.

Knights of Labour, a national labour organisation in the United States, founded at Philadelphia in 1869. It is to be distinguished from trades-unions as embracing all classes and kinds of labour, even clerks, sempstresses, &c., and extending, through its local assemblies, over the whole country. The professed objects of the body are just and reasonable, and such as appeal strongly to public sympathy. The first general assembly was held in 1878; from this year the numbers rapidly increased, and the oaths of secrecy formerly administered were abolished soon after. In 1883 there were 53,000 members, in 1886 there were 730,000; in 1886 and 1887, however, the system of 'boycotting' having been introduced, the business of the country was greatly disturbed, and since then the strength of the organisation has declined. At the convention of 1888 the total was admitted to have fallen below 500,000; and dissensions further weakened the body. Unavailing opposition to the policy of the leaders led to many withdrawals, and the power of the organisation was weakened. See GRANGERS, INTERNATIONAL, TRADE UNIONS.

Knights Templars. See TEMPLARS.

Knipperdolling, BERNARD, a noted leader (1527-36) of the fanatical Anabaptists (q.v.).

Knitting. See HOSIERY.

Knock, a village in County Mayo, Ireland, 17 miles ESE. of Castlebar, where an alleged luminous apparition of the Virgin appeared on the chapel wall in 1880. For a considerable time afterwards crowds of pilgrims flocked to the scene, and numerous miraculous cures were reported. Pop. of parish, 3241.

Knock-knee. See LEG.

Kuole. See SEVENOAKS.

Knot (*Tringa canutus*), a wading shore-bird of the family Scolopacidae, in the same genus as the dunlin, stints, &c. It is a regular autumn visitor to Britain, especially to the eastern estuaries, but breeds in the far north, and ranges as far south as the West Indies. The general colour, in summer, is reddish brown, finely mingled with black, gray, and white; in winter the plumage becomes mostly ash gray, and on the under parts white. The total length is about 10 inches. Its food consists in great part of small bivalves, but birds and insects are also eaten. The bird used to be caught and fattened for the table.

Knot, the divisions of the log-line on board ship, marked by *knots*, each having the same relation to a geographical mile as twenty eight seconds has to an hour. Hence the number of knots in the log line which run out in twenty eight seconds represents the number of geographical or nautical miles an hour which the ship is going at the time. The geographical mile is $\frac{1}{60}$ th of a mean degree of a meridian on the earth (see DEGREE), and is therefore $\frac{1}{60}$ th of 69.055 English statute miles; hence when a ship is going '13 knots,' it is travelling really at the rate of about 15 English miles an hour. See LOG.

Knots and **Splices** include all the various methods of tying, fastening, and joining ropes or cords. From 150 to 200 different kinds of knots may be enumerated, mostly used on shipboard,

though almost all occupations using ropes or cordage have special kinds of knots adapted to their different requirements. While the great majority of these are purely technical, there are a few so generally useful in the everyday occurrences of life that they may be shortly described. The figures represent the various knots before they are drawn taut, the better to show the method of tying. Generally, the requirements of a useful knot may be stated to be that it should neither 'slip' nor 'jam'—i.e. that, while it holds without danger of slipping while the strain is on it, when slackened it should be easily untied again. The simplest knot is the common one tied on the end of a thread or cord to prevent it slipping. By passing a loop instead of the end of the cord the common slip-knot (fig. 1) is formed; and a useful fixed loop is got by tying a simple knot, or the 'figure of 8 knot' (2), on the loop of a cord. One of the simplest and most useful running-knots for a

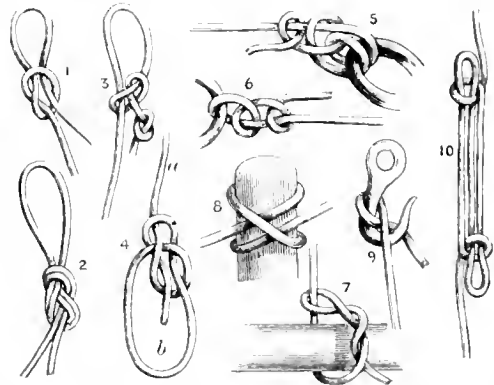

small cord is made by means of two simple knots (3). The most secure method of fastening a line to, say, a bucket is the standing bowline (4); and a running bowline is formed by passing the end *a* through the loop *b*, thus making a running-loop. Another good knot to make fast a bucket is the anchor-bend (5). Out of the score or so of methods of fastening a boat's painter the one which will be found most useful is the well-known two half-hitches (6). The timber-hitch (7) is useful for attaching a line to a spar or a stone, and the clove-hitch (8) is invaluable for many purposes. It is very simple and cannot slip.

A simple method of fastening a rope to a hook is the blackwall-hitch (9), where the strain on the main rope jams the end so tightly against the hook that it cannot slip. There are many methods for shortening a rope temporarily, one of them being the sheepshank, the simplest form of which is shown in fig. 10.

Of the methods for uniting the ends of two

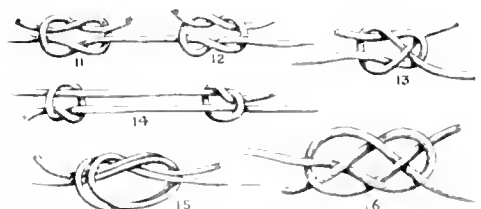

cords the simplest and one of the most secure is the common reef-knot (11), which must be carefully distinguished from the 'granny' (12), which will jam if it does not slip; the reef-knot will

do neither. For very small cords or thread the best knot is the weaver's (13). The fisherman's knot is a very useful one for anglers, and is formed by a simple knot in each cord being slipped over the other (14); when drawn taut it is very secure, and it is easily separated by pulling the short ends. A useful method of uniting large ropes is shown in fig. 15: tie a simple knot on the end of one rope and interlace the end of the other, and draw taut. This tie may also be made with the figure of 8 knot. For very large ropes the carrick-bend (16) is the simplest and most secure. The bowline-bend is formed by looping two bowline-knots into each other. For attaching a small line to a thick rope the becket-hitch (17) is very useful.

Splicing is the process employed to join two ropes when it is not advisable to use a knot. The three chief varieties of the splice are the short-splice, the long-splice, and the eye-splice. The short-splice is made by unlaying the ends of two

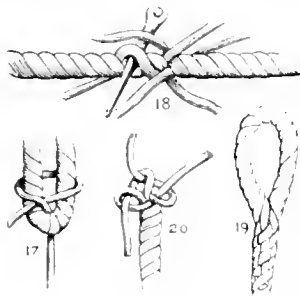

ropes for a short distance and fitting them closely together; then, by the help of a marlinspike, the ends are laced over and under the strands of the opposite rope, as shown in fig. 18. When each strand has been passed through once, half of it is cut away and the remainder passed

through again; half of the remainder being also cut away, it is passed a third time, and, when all the strands are so treated, they are hauled taut and cut close. This reducing the thickness of the strands tapers off the splice. The long-splice is employed when the rope is used to run through a block, as it does not thicken it. The ends of the two ropes are unlaid for a much longer distance than for the short-splice, and similarly placed together. Then one strand is taken and further unwound for a considerable distance, and its vacant place filled up with the corresponding strand of the other rope, and the ends fastened as in the short-splice. Other two of the strands are similarly spliced in the opposite direction, and the remaining two fastened at the original joining-place. The eye-splice is, as the term implies, used to form an eye, or round a dead-eye, and is shown finished in fig. 19.

To prevent a rope fraying at the ends a variety of methods are employed, the simplest being to serve or whip the end with small cord. Other methods are by interlacing the ends, one of which, the single-wall, is shown at fig. 20, the ends afterwards being drawn taut and cut short.

The theory of knots, from the scientific point of view, was first treated by Listing in his 'Vorstudien zur Topologie' (*Göttinger Studien*, 1817); and the subject is most exhaustively considered by Professor Tait (*Trans. Roy. Soc. Edin.*, 1876-77), in a paper in which the various kinds of knots are analysed according to their number of crossings, and their 'knottiness,' 'beknottedness,' and 'knotfulness' are dealt with.

See Dana, *Seaman's Manual* (9th ed. 1863); Tom Bowling, *Book of Knots* (1866); Captain Alston, *Seamanship* (new ed. 1871); J. Tom Burgess, *Knots, Ties, and Splices* (1884).

Knout, an instrument of punishment introduced into Russia under Ivan III. (1462-1505). It was a whip with a handle 9 inches long and one complex lash, comprising a lash 16 inches long, with a metal ring; a continuation with another ring; and

finally, a flat lash of hard leather, 21 inches long, and ending in a beak-like hook. The offender was tied to two stakes, stripped, and received on the back the specified number of lashes; 100 to 120 were equivalent to sentence of death, but in many cases the victim died under the operation long before this number was completed. The whipping was inflicted by a criminal. For the knout Nicholas substituted the *plet*, a three-thonged lash, and this was disused, save in certain penal settlements, by Alexander II. (Knout is the French spelling of a Russian word spelt by the Germans *knut*, and by Russians, Germans, and French alike pronounced *knuot*; in English, usually but absurdly *nout*).

Knowles, JAMES SHERIDAN, dramatist, was born at Cork, 21st May 1784, the son of a lexicographer and teacher of elocution, who was cousin-german to Richard Brinsley Sheridan. The family removed to London in 1793, and here young Knowles became intimate with Hazlitt and Lamb. He had early shown a strong bent for an actor's life, and after serving a while in the militia, and studying medicine for a time, he made his first appearance at the Crow Street Theatre, Dublin. But he never attained much eminence in this profession, and subsequently he conducted a school for several years in Belfast and Glasgow. It was at this time he laid the foundation of his fame as a dramatist. His *Brian Boroiawc* (1814) and *Caius Gracchus* (1815) were first performed at Belfast. *Vivianus*, his most effective play, had been a success in Glasgow before Maeready in 1820 produced it at Covent Garden. Besides *William Tell*, in which Maeready achieved one of his greatest triumphs, Knowles's best plays are *Love, The Hunchback, The Love Chase, and The Wife*. His works attract by the strong human feeling that beats beneath their antique dress, and several of them are still among standard acting-plays. Knowles appeared with fair success in many of his own pieces; but in his later years he forsook the stage for the pulpit, became a Baptist preacher, and drew large audiences to Exeter Hall. His earnestness and enthusiasm were great, and two controversial works written to combat Roman Catholic doctrines displayed considerable acuteness. From 1849 Knowles had a civil list pension of £200 a year. He died at Torquay, 30th November 1862.

Knowltonia, a genus of South African plants, of the natural order Ranunculaceæ. *K. vesicataria* is remarkable for its acridity and blistering power. The bruised leaves are used at the Cape of Good Hope instead of cantharides.

Know Nothings, the popular name for the Native American party which was formed in the United States shortly before 1855, gained considerable successes in that year, lost its ground hopelessly in 1856, and soon after disappeared from American politics. Its distinctive principle was that the government of America must be in the hands of Americans; naturalisation was to follow only after twenty-one years' probation, and allegiance to any foreign potentate or power—presumably including the pope—was to be a bar to selection for political office. The order was a secret one, and the popular name arose from the members professing always to 'know nothing' when questioned about it. In the state elections of 1855 the party carried most of New England, besides New York, Kentucky, and California, and gained some successes in other states. In 1856 they nominated Mr Fillmore (q.v.) for reelection to the presidency, and polled nearly 875,000 votes; but they gained the electoral votes of Maryland only, and this defeat was the death-blow of the party. Nevertheless, its radical principle, in the form of revolt against the tendency to allow political power to fall into

the hands of a particular body of foreign-born citizens, occasionally reappears in American politics. In Boston, for instance, in 1889 the native-born citizens combined to snatch the city government from Irish hands; and the unsuccessful attempt to defeat the Tammany Hall nominees at New York at the same time exhibits a similar reaction at work.

Knowsley, a village of Lancashire, 5 miles NE. of Liverpool, where—one mile from the village—is Knowsley Hall, the seat of the Earl of Derby, which contains valuable paintings by Rubens, Rembrandt, Teniers, Claude Lorraine, and other great masters.

Knox, JOHN, the great Scottish Reformer, was born at Giffordgate, a suburb of the town of Haddington, in 1505, the year preceding the birth of his famous countryman, George Buchanan. Knox has himself told us in a single sentence all that is definitely known of his family connections. 'My lord,' he represents himself as saying to the notorious Earl of Bothwell, 'my grandfather, grand-sire (maternal grandfather), and father have served under your lordship's predecessors, and some of them have died under their standards.' He received the elements of his education in the grammar-school of his native town, and in 1522 was sent to the university of Glasgow. St Andrews was nearer his home, and possessed the more famous university; but he was probably drawn to Glasgow by the fame of the most distinguished literary Scotsman of his generation—John Major, the schoolman. For this reason, at least, Buchanan was sent to St Andrews, though Glasgow was nearer his native place, when Major had migrated to the former university. At Glasgow, under Major, Knox could have been subjected to none of the influences of the great intellectual revolution which substituted for the studies and methods of medievalism the ideals of the Revival of Letters. Like all his educated contemporaries, he learned to speak and write Latin with perfect fluency; but it was always with an idiom that showed he had none of the humanist's scruples regarding purity of language. What he learned from Major was the art for which that scholar was renowned throughout Europe, the art of logical exercitation; and Knox's writings everywhere show that all through life he had a natural delight in the play of dialectic. He left the university without taking the degree of Master of Arts, thus by the conditions of all the medieval universities precluding himself from the career of an academic teacher.

During the eighteen years that follow his leaving the university Knox passes completely out of sight. All that is known of him during this period is that from 1519 to 1543 he acted as notary in his native town of Haddington. As in the documents that establish this fact his name appears with the addition of 'Sir,' the title of priests who were not Masters of Arts, Knox must have been in orders in the Church of Rome till as late as 1543. In 1544 we find him acting as tutor to the sons of Douglas of Longniddry and Cockburn of Ormiston families, it is to be noted, both favourably disposed to the new opinions in religion now rapidly making their way in Scotland. Through these families he was brought into contact with George Wishart, who had lately returned from travelling in Germany and England with the burning zeal to gain his country to the Lutheran reformation. From this period the future direction of Knox's life was decided, and thenceforward with an intensity and self-devotion never surpassed he is the apostle of the cause with which his name is for ever identified—the establishment in Scotland of what he deemed the only true conception of the primitive church as based on the teaching of Christ

and the apostles. We have reason to believe that even before this date his sympathies were on the side of reform in religion; but the teaching and example of Wishart seems first to have brought to him the clear consciousness of his mission. Knox identified himself with Wishart with all the impetuosity of his character, and was in the habit, he tells us, of carrying a two-handed sword before the preacher. When Wishart was seized by the emissaries of Cardinal Beaton, Knox would willingly have attended him to the last; but Wishart, who knew the fate in store for him, rejected the offer. 'Return to your bairns' (meaning Knox's pupils), he said, 'and God bless you. One is sufficient for one sacrifice.'

Wishart was burned at St Andrews in March 1546, and in May of the same year Cardinal Beaton was murdered. The cardinal's murderers held possession of the castle of St Andrews; and, as Knox was known to be the enemy of Beaton (though he had no share in his assassination), he was forced (1547) for his own safety to join them with his pupils. Here his zeal and theological attainments made him so conspicuous that, at the instance of the leaders of the reforming party (Sir David Lindsay among the rest), he was formally called to the ministry, and preached with much acceptance in the castle and parish church of St Andrews. A few months later the castle surrendered to the French; and in the teeth of the express terms of capitulation, the more prominent of the besieged party were sent as prisoners on board the French galleys. For eighteen months Knox remained a captive, his first winter being spent in a galley on the Loire, the second in prison in Rouen. His constitution was not naturally robust, and his hard experience during these two years seriously impaired his health for the rest of his life. The breach of faith on the part of the French, and the ignominy to which he was subjected, were never forgotten by Knox, and must in part explain and justify his life-long conviction that no good thing could come of French policy or French religion.

In February 1549, on the express intercession of Edward VI., Knox regained his liberty. As it was still unsafe for him to return to Scotland, for the next four years, till the death of Edward VI., he made his home in England. From all that is known of him during these years it is clear that he made himself a person to be reckoned with by those at the centre of authority in the country. By his preaching at Berwick he gave such offence to the Bishop of Durham that he was removed to Newcastle, where it was supposed his influence would be less mischievous. In 1551 he was appointed one of six chaplains to Edward VI., and in 1552, at the suggestion of the Duke of Northumberland, he was offered the bishopric of Rochester. As the duke's object in suggesting the appointment was simply to check, as far as he could, what he deemed the dangerous activity of Knox, the offer was unhesitatingly rejected. Knox's importance in England is still further proved by the fact that along with five others he was consulted by Archbishop Cramer regarding his forty-five (afterwards forty-two) articles of religion; and it has been lately established that largely on Knox's representation the thirty-eighth article was so couched as to commit the Church of England to the Geneva doctrine of the eucharist.

On Mary's accession Knox, like the majority of the Reformed ministers, had to seek refuge on the Continent. That he might be within call should circumstances permit his return either to Scotland or England, he took up his abode at Dieppe till the beginning of the following year (1554), when he proceeded to Geneva. In July of this year he was again in Dieppe, 'to learn the estate of Eng-

land; but with Mary of Lorraine as regent in Scotland, and Mary Tudor as queen of England, he was convinced that for the present both these countries were closed against him. He accordingly accepted a call from the English congregation at Frankfort on-the-Main, where, however, on account of a dispute regarding the use of the Book of Common Prayer, he remained only a few months. At Geneva he found a congregation of his own way of thinking; but, eager to be an apostle in his own country, he once more returned to Dieppe (August 1555), whence he ventured into Scotland in September. He remained in Scotland till July of the next year, residing chiefly in Edinburgh, but making preaching journeys into various parts of the country. The new doctrines were steadily spreading in Scotland, but as yet their supporters were not strong enough to present a confident front against the government. It was at his own risk, therefore, that Knox remained in the country; and at the prayer of the congregation in Geneva he returned to that town in July 1556. It was probably during this visit to Scotland that he married his first wife, Marjory Bowes, to whom he seems to have been engaged during his sojourn in Newcastle. For the next two years he remained in Geneva, ministering to his congregation, and seeing much of Calvin, whose influence on Knox regarding all the great questions of the time was afterwards to bear fruit in the ordering of affairs in Scotland. To this period, also, belong several of his minor writings, and notably his *First Blast of the Trumpet against the monstrous Regiment of Women*, the publication of which he must afterwards have regretted in the interest of the cause he had most at heart.

Meanwhile, in Scotland the ground was being prepared for the great work in store for Knox. Under Mary of Lorraine as regent, the French influence had come to be regarded as a danger to the independence of the country, and a sense of this danger threw many into the party of reform. The unworthy lives of the old clergy, and the cupidity of many of the nobles, worked in the same direction. In 1557 the advocates of reform bound themselves by what is known as the *First Covenant* to do all in their power to effect a religious revolution; and by 1558 they felt themselves strong enough to summon Knox to their aid in the work he deemed the mission of his life.

In May 1559 Knox found himself again in Scotland, which he never again left for a prolonged period. He at once became the life and soul of his party. At the moment of his arrival the Lords of the Congregation, as the Protestant nobility termed themselves, were in open revolt against the regent. By his preaching at Perth and St. Andrews Knox gained these important towns to his cause, and by his labours in Edinburgh, of which he was appointed minister, he also won a strong party against the government. But the Reformers of their own resources could not hold their ground against the regent, subsidised by France with money and soldiers. Mainly, therefore, through the efforts of Knox, who all through his public career was deep in the politics of the time, the assistance of England was obtained against what was now deemed the French invasion. The help of England proved effective; and by the treaty of Leith (1560), and the death of the regent the same year, the insurgent party became masters of the country. The Estates of Parliament having met on August 1st, the ministers were ordered to draw up a Confession of Faith which should embody the new teaching; and on August 17th Protestantism was formally established as the religion of the country. Having gained thus much, the ministers, desirous of practical results from their victory, drew up the first *Book of Discipline*—a document ever memorable in the

history of Scotland, and admirable in itself for its wise and liberal suggestions for the religious and educational organisation of the country. These suggestions, however, were little to the mind of the majority of the Protestant nobles, who, 'perceiving their carnal liberty and worldly commodity to be impaired thereby,' sneeringly spoke of them as 'devote imaginations.' In the revolution that had been accomplished Knox had been the leading spirit; but he saw that the victory was as yet only half gained, and that the deadliest struggle had still to be decided.

The return of the young queen to Scotland (August 1561) revived all the old dissensions, and introduced new elements into the strife of parties. By every opinion she held on religion, on the relations of prince and subject, on the fundamental principles of life, Mary was separated as by an abyss from the party represented by Knox. If we may judge from the language which each held of the other, Knox and she failed to find one point on which genial intercourse was possible. As the minister of St. Giles (then the only Reformed church in Edinburgh), Knox believed that Mary was his special charge. Her personal conduct, therefore, no less than her public policy, was made the subject of his most stringent criticism; and during the six years of her reign his attitude towards her was that of uncompromising antagonism. The celebration of mass in Holywood Chapel in defiance of the late religious settlement first roused his wrath; and a sermon delivered by him in St. Giles led to the first of those famous interviews with Mary, the record of which makes such a remarkable portion of his *History of the Reformation*. The division of ecclesiastical property, by which those in actual possession received two-thirds, the Reformed ministers one-third, was a further ground of quarrel with the new government. The delay of Mary to confirm the late religious settlement also gave rise to the gravest anxiety on the part of Knox and his brother ministers. In view of the precarious interests of the great cause, Knox spoke out with such frankness as to alienate the most powerful noble in the country, and the one whom he respected most—Lord James Stuart, afterwards the Regent Moray. The marriage of Mary with Darnley (1565) again, however, led them to common counsel, as both saw in this marriage the most serious menace against the new religion. In the subsequent revolt, headed by Moray and the other Protestant nobles, Knox nevertheless took no part, and remained at his charge in Edinburgh. But after the murder of Rizzio he deemed it wise, considering Mary's disposition towards him, to withdraw to Kyle in Ayrshire, where he appears to have written the greater part of his *History*.

The events of the next two years—the murder of Darnley, Mary's marriage with Bothwell, and her subsequent flight into England—again threw the management of affairs into the hands of the Protestant party; and under Moray as regent the acts of 1560 in favour of the Reformed religion were duly ratified by the Estates of the Realm. As in the former revolution, Knox was still the same formidable force the nobles had to reckon with; and at Stirling at the coronation of James VI. (1567), and at the opening of parliament the same year, he preached in that strain which gave his sermons the character and importance of public manifestoes. The assassination of Moray in 1570, and the consequent formation of a strong party in favour of Mary, once more endangered the cause to which he had devoted his life, and the possession of the castle of Edinburgh by the queen's supporters forced him to remove to St. Andrews for safety. He had already had a stroke of apoplexy,

and he was now but the wreck of his former self, but his spirit was as indomitable as ever. The description of him at this period by James Melville can never be omitted in any account of Knox. 'Being in St Andrews he was very weak. I saw him every day of his doctrine go hulle and fear, with a furring of martvicks about his neck, a staff in the one hand, and good godly Richart Ballanden, his servant, holding up the other oxtar, from the abbey to the parish church; and he the said Richart and another servant lifted up to the pulpit, where he behaved to lean at his first entry; but or he had done with his sermon, he was so active and vigorous that he was like to ding that pulpit in blades, and fly out of it.'

It was the desire of his congregation of St Giles to bear him once more before he died. Accordingly, by short stages, he made his way to Edinburgh, and on the 9th November 1572, at the induction of his successor in office, he made his last public appearance. He died the same month at the age of sixty-seven, and was buried in the churchyard then attached to St Giles, behind which church a small square stone in the pavement of Parliament Square, marked 'I.K., 1572,' now indicates the spot where he is supposed to lie. The saying of the Regent Morton at his grave, 'Here lyeth a man who in his life never feared the face of man' (Cadderwood), was the most memorable panegyric that could have been pronounced to his memory.

Knox was twice married. His first wife, Marjory Boyes, died in 1560, leaving him two sons. By his second wife, Margaret Stewart, daughter of Lord Ochiltree, whom (little more than a girl) he married in 1564, he had three daughters. His widow and all his family survived him.

In their broader features the character of Knox and of the work he achieved cannot be misread. In himself he stands as the pre-eminent type of the religious Reformer—dominated by his one transcendent idea, indifferent or hostile to every interest of life that did not subserve its realisation. He is sometimes spoken of as a fanatic; but the term is hardly applicable to one who combined in such degree as Knox the shrewdest worldly sense with an ever-ready wit and a native humour that declares itself in his most serious moments and in his treatment of the loftiest subjects. To blame him for intolerance or harshness is but to pass judgment on his age and on the type to which he belongs. It is his unquestionable tribute that the work he accomplished was the fashioning anew of his country's destinies. The revolution he was the main instrument in effecting was not merely the substitution of one set of dogmas for another; it was the transformation of the national ideals, the quickening of the national life, the victory of principles which eventually assured to Scotland the free and natural development of the life of her people. It has to be added that by his *History of the Reformation in Scotland* Knox holds a place of his own in the history of literature. His narrative, as was to be expected, is that of one who saw only a single aspect of the events he chronicles; but the impress of the writer's individuality, stamped on every page, renders his work possibly unique in English literature.

See McOric, *Life of Knox* (1811; 7th ed. 1855); *The Works of John Knox*, edited by David Laing (6 vols. 1846-64); Carlyle, *Heroes and Hero-Worship*; Lorimer, *John Knox and the Church of England* (1875); short works by Mrs MacCunn (1895) and Taylor Innes (1896); and the Life by the present writer (1895).

Knoxville, a city of Tennessee, stands amid picturesque scenery on the Holston River, at the head of steamboat navigation, 165 miles E. of Nashville. It is a railway junction, and has manufactures of iron goods, wooden wares, flour,

&c. Here are the state university and the agricultural college, the state school for deaf-mutes, an industrial school for coloured pupils, and a handsome post-office. Pop. (1880) 10,917; (1890) 22,535.

Knur and Spell (called by Strutt 'Northen Spell'), an old English game played with a ball, which is 'risen' from a trap and hit with a bat made for the purpose. The ball, called the 'knur,' is made of wood, a little bigger than a walnut. The bat, called a 'tripstick,' as it is also used to spring the trap or 'spell,' consists of a piece of hard wood, 6 by 4 inches, and 1 inch thick (the pommel), attached to a supple handle from 3 to 4 feet long, which the player grasps with both hands, giving the full swing of his body with the stroke. The game consists of the cumulative distance of a given number of strokes, the player who has the greatest number of yards being the winner.

Knutsford ('Canute's ford'), a pleasant-looking town of Cheshire, 15 miles SW. of Manchester by rail, the Cranford of Mrs Gaskell's sketches, with manufactures of cotton, worsted, and leather goods, and a pop. of (1851) 3127; (1881) 4290. In 1888 the elder son of Sir Henry Holland (q.v.) was created Baron Knutsford. See H. Green's *History of Knutsford* (1859).

Knysna, a forest track and elephant preserve, extending from the sea to the Outeniqua Mountains in Cape Colony, 150 miles W. of Port Elizabeth.

Koala (*Phascolarctus cinereus*), a marsupial, restricted to eastern Australia, of the family Phalangeridae, and pretty nearly resembling the Phalangers in dentition, but having the molar teeth much larger. The toes of the fore-feet are in two opposable groups, of two or three, a character



Koala (*Phascolarctus cinereus*).

not found in any other quadruped, but well adapted to grasping the branches of trees, on which the koala often hangs with its back undermost, like the sloth. There is scarcely any rudiment of a tail. The general form is not unlike that of a young bear, whence the name of 'Native Bear.' The female carries her young on her back for a long time after it is capable of leaving her pouch.

Kobbe. See DAR-FER.

Kobolds. See GÖBLIN, DEMONOLOGY.

Koch, KARL, botanist, was born at Weimar, 6th June 1809. He studied at the universities of Würzburg and Jena, and in 1836 undertook a scientific journey to southern Russia. In 1843-44 he visited Armenia, Kurdistan, Transcaucasia, and the Crimea. He was appointed extra-ordinary professor of Botany at Jena in 1836, and in 1848 at Berlin, where he died, 25th May 1879. His chief work is his *Dendrologie* (1869-72); but he also published several books of travel, *Beiträge zu einer Flora des Orients* (6 parts, 1848-54), and a map of Transcaucasia and Armenia.

Koch, ROBERT, an eminent bacteriologist, was born at Klausthal, in the Harz, 11th December 1843, studied at Göttingen, and practised medicine at Hanover and elsewhere. His investigations in connection with wounds, septicæmia, and splenic fever gained him a seat on the imperial board of health in 1880; and his further researches in microscopy and bacteriology led to his discovery in 1882 of the *Bacillus tuberculosis*. In 1883 he was made a privy-councillor, and appointed leader of the German expedition sent to Egypt and India in quest of the cholera germ (see BACTERIA, fig. 5; also CHOLERA). In 1885 he was appointed professor at Berlin, and in 1891 director of the new institute for infectious diseases. He made valuable investigations on rinderpest in South Africa, leading to a method of prophylactic inoculation; and in 1898 he began a two years' series of investigations on malarial fever in Italy, Greece, East Africa, India, and New Guinea. For Koch's postulates, see GERM; and for his tuberculin, see TUBERCLE, p. 317. He has written on splenic fever (1876 and 1882), on wound poison (1878), and other subjects.

Kock, CHARLES PAUL DE (1794-1871), born at Passy, near Paris, was the son of a Dutch banker who perished on the scaffold during the French Revolution. He devoted himself to literature against the wishes of his relatives, and produced an endless series of novels, vivacious, piquant, and readable, but hardly reaching the dignity of literature. However, they will retain their value as pictures of lower middle-class life in Paris in the first half of the 19th century, especially in its shadier sides; and they display a marvellous fertility in the invention of incidents, more or less equivocal in character, in the life of the French bourgeoisie, its *cabarets*, and its *quaiettes*. His undeniable gifts are marred by a coarse vulgarity that seems in grain, and an utter absence of style. Yet his stories were for long immensely popular, and we know that for thirty years they were the sole reading of Major Pendennis. Here may merely be named *Georgette; Gustave; Le Barbier de Paris; La Femme; le Mari et l'Amant; Mœurs Parisiennes*. The collected edition of his works fills 56 vols. (1844-45). See his *Memoires written by Himself* (1899). **HENRI DE KOCK**, his son (born 1821; died 17th April 1892), followed his father as closely as he could, with a series of far weaker novels. Another work is his *Souvenirs de Napoleon III. a Wilhelmshöhe* (1871).

Kodiak. See KADIAK.

Kohat, the headquarters of Kohat district, in the Punjab, is pleasantly situated in a mountain-valley, 37 miles S. of Peshawar. It is surrounded by a wall 12 feet high, and has cantonments to the east and a fort to the north. Guns and rifle-barrels are manufactured near by. Pop. (1881) 18,179; (1891) with cantonment, 27,003. The district has an area of 2771 sq. m., and a pop. of 203,175.

Kohleth. See ECCLESIASTES.

Koh-i-nûr. See DIAMOND.

Kohistan, a name given to certain mountainous regions in Persia, Afghanistan, and Turkestan.

Kohl. See ALCOHOL.

Kohl, JOHANN GEORG, traveller and author, was born at Bremen, April 28, 1808, studied at Göttingen, Heidelberg, and Munich, and settled in Dresden in 1838. From this point he made excursions to every important district of Europe, and on his return from each expedition published his experience in a series of works. In 1854 he went to America, where he spent four years, and prepared a series of maps for the government. Returning to Germany he became city librarian at Bremen, and there died on 28th October 1878. His

writings include works on Austria, Britain, the Rhine, the Alps, Russia, Denmark, the Netherlands, Istria, Dalmatia, and Montenegro (all between 1842 and 1851); also books of travel in Canada (1856) and the United States (New York, 1857); and histories of the discovery of America (1861; Eng. trans. 1862), of the north-eastern coast of America ('Maine Historical Collections,' Portland, 1869), and of Magellan Strait (1877).

Köhler, REINHOLD, a learned student of the history of literature, was born at Weimar, 24th June 1830, studied philology at Jena, Leipzig, and Bonn, and accepted in 1857 the post of a librarian in the ducal library at Weimar, of which he became the chief in 1881. Besides numerous contributions to the learned journals, such as his admirable notes on J. F. Campbell's tales in Benfey's *Orient und Occident* (vol. ii. 1864), he published works on the *Donquixote* of Nomms (1853), on Kleist's Works (1862), on Herder's *Civil* and its sources (1867); and edited *Alte Bergmannslieder* (1858), four dialogues of Hans Sachs (1858), *Kunst über alle Künste* (a 1672 translation of Shakespeare's *Titus of the Shrew*), Dante and the German translations (1865), Wieland's *Oberon* (1868), and Schiller's *Ästhetische Schriften* (1871). His admirable notes to Krenzwald's *Estnische Märchen* (1869) and Laura Gontzenbach's *Schwedische Märchen* (1870) are known to all folklorists. He died 15th August 1892.

Kohl-rabi (Ger. *Kohl-rübe*, 'Kale-turnip;') so French *Chou Rave*), a cultivated variety of the Kale or Cabbage (*Brassica oleracea*), distinguished by the swelling of the stem just above the ground, in a globular form, like that of the turnip, but with the leaf-stalks springing from the swollen part, and adding to the peculiarity of its appearance. This is the part which is used, and its uses are similar to those of the turnip. It is a common field-crop in Sweden.

Koïl. See ALIGARH.

Koko-nor, or KUKU-NOR, a lake of Tibet, near the frontier of the Chinese province of Kan-su, fills a depression surrounded by mountains, and lies, according to Prjevalsky, 12,097 feet above the level of the sea. Its very salt waters, exquisitely blue in colour, cover 66 miles by 40. It contains five islands, one with a Buddhist monastery.

Kok-ra Wood, or COCTS WOOD, the wood of an Indian tree, *Lepidostachys Roeburghii*, which belongs to a very small natural order, Scapaceæ. It is imported into Britain in logs of 6 or 8 inches in diameter, having the heart-wood of a rich deep brown colour and very hard; and is much used in the manufacture of flutes and other musical instruments.

Kokstadt. See GRIQUALAND EAST.

Kola, a place of only 770 inhabitants, but worthy of notice as the most northern town of European Russia. It is situated on the peninsula of Kola, is the capital of Russian Lapland, and has a spacious harbour. The peninsula of Kola is a dreary expanse of forests and lakes, but has several ranges of mountains, one of which, the Umbalek Mountains, on the east side of Lake Inandra, rising to 3300 feet, is the second highest (after the Caucasus) in Russia. See Rae's *White Sea Peninsula* (1882).

Kola Nuts, or GURU NUTS, the seeds of *Sterculia acuminata*, a tree native to the regions of Africa south of 7° 30' lat. From the 17th century traders brought home marvellous stories of these nuts; but it was in 1865 that Dr Daniell discovered that they contained an alkaloid identical with that found in tea, coffee, mate, and guarana, and from that time they have received more attention. In the Soudan they are valued so highly that no greater honour can be given than the presentation

of some of the nuts. In times of drought a single nut has bought a slave, while a bride of the highest family has often been sold for a handful. This excessive value is due to the possession of remarkable virtues, the explanation of which is still wanting. The natives chew the nuts, extracting the juice and spitting out the fibrous matter. By means of it they profess to withstand hunger, thirst, sleep, and exhaustion. Analysis reveals only about 2 per cent. of theine, tea and coffee containing from $\frac{1}{2}$ to 3 per cent., while there is also a small amount of volatile oil; but this does not account for all its virtues, and the explanation given is that it is used in the fresh state, and, like coca, loses its powers on drying. In Africa the seeds are only transported when carefully wrapped in leaves resembling lotus, and are frequently moistened. As imported into Europe they undoubtedly, like tea and coffee, possess a stimulant value, but beyond that their virtues are doubtful. In Africa they possess a reputation for purifying and clarifying muddy water, but it does not appear that they are superior to other mucilaginous seeds for this purpose. In certain forms of diarrhoea they are useful, and may be taken, like tea, as a decoction. They have been recommended for dipsomania, but their utility in this respect is small. The rotten nuts and those which had become dry began to be exported in 1877 to Germany and France, for the purpose of mixing with chocolate; and in recent years various preparations—kola paste, chocolate, aerated water, &c. have been introduced, the value of which is doubtful. Dilute alcohol extracts most colouring and extractive matter from the seeds, and this tincture or a decoction may be used for administering them; but the best and simplest way is to chew the seed by itself, or take the powder mixed with some sweetening material.



Sterculia acuminata:
a, the nut.

Kolapur (*Kolhapur*), the capital of a tributary state in Bombay, 141 miles S. by E. of Poona, with many handsome modern buildings and an active trade. Pop. (1891) 45,815.—*Kolapur state* has an area of 2816 sq. m., and a pop. of 913,131, nine-tenths Hindu.

Kolarians. See INDIA, Vol. VI. p. 103.

Kolguef, or KALGUEF, an island of Russia, in the Arctic Ocean, belonging to the government of Archangel. Area, 1350 sq. m. It is visited in summer by fur-hunters, walrus-hunters, and fowling, who capture eider-ducks, swans, and other seabirds that yield down. The only permanent inhabitants are a few Samoyedes.

Kolin, or KOLLIN, a town of Bohemia, on the Elbe, 38 miles by rail E. by S. from Prague, is a centre of the sugar industry of the country, and manufactures chemicals, oil, metal wares, &c. Pop. 11,636. A great battle was fought, June 18, 1757, in its vicinity between 54,000 Austrians under Marshal Daun and 31,000 Prussians under

Frederick II. The latter were defeated with a total loss of 14,000 men; the Austrians lost 8000.

Kollar, JAN, Slavonic poet and scholar, was born 29th July 1793 at Mossoez, in the north-west of Hungary, studied at Presburg and Jena, and in 1819 became pastor of a Protestant congregation at Pesth. His first work was a volume of *Poems* (1821); this was followed by an enlarged edition of the same entitled *The Daughter of Glory* (1824), his greatest work. He also published a collection of Slavonic *Folk-songs* (2d ed. 1832-33), and some books on the Slavonic peoples and languages. He was made professor of Archaeology at Vienna in 1849, and died there, January 24, 1852. See the Autobiography included in his *Collected Works* (2d ed. 4 vols. Prague, 1868).

Kölliker, ALBERT VON, anatomist and embryologist, was born at Zurich on 6th July 1817, studied natural sciences at Zurich, Bonn, and Berlin, was appointed professor of Physiology and Comparative Anatomy at Zurich in 1845, and in 1847 exchanged this for the chair of Anatomy at Wurzburg. He is principally distinguished by his labours in the department of microscopic anatomy and on the development of the embryo. Among his principal works must be named his *Handbuch der Gewebelehre des Menschen* (translated for the Sydenham Society by Bask and Huxley as *A Manual of Human Histology*), *Die Siphonophora oder Schwammthiere von Messina*, the *Challenger Report on Penmatulida* (vol. i. 1880), and *Entwickelungsgeschichte des Menschen u. d. höheren Thiere*. In association with Von Siebold he started the important *Zeitschrift für wissenschaftliche Zoologie*.

Köln. See COLOGNE.

Kolouca, a town of Austrian Galicia, on the Pruth, 43 miles by rail NW. of Czernowitz. Situated not far from a rich petroleum region, it has works for refining petroleum and for making paraffin candles. Pottery is, however, the staple manufacture. Pop. 30,160 (nearly half are Jews).

Kolonna, a town of Russia, on the Moskva, 68 miles by rail SE. of Moscow. It manufactures silk, linen, leather, soap, and machines. Pop. (1894) 28,323. Here the Mongols under Batu defeated the Russians in 1237.

Kolosvár. See KLAUSENBURG.

Koltzoff, ALEXEI VASSILIEVICH (1809-42), a Russian poet of the people, left but few songs, yet those among the choicest lyrics of Russian poetry.

Kolyta, a river of eastern Siberia, flowing from the Stanovoi Mountains 995 miles north east to the Arctic Ocean. It is only free from ice during eleven weeks in the year. Its waters are full of fish.

Kouorn, a town and fortress in Hungary, situated on the island of Schutt, in the Danube, which is here crossed by a bridge of boats, 48 miles NW. of Pesth. The town, which is irregularly built, with narrow, gloomy streets, contains (1891) 13,072 inhabitants, who trade in corn and timber, cultivate the vine, and carry on fishing. The fortress, one of the strongest in Europe, commenced in the end of the 13th century, was greatly enlarged and strengthened by Matthias Corvinus; the fortifications were again restored and improved in 1805-9. It requires for its defence at least 15,000 men and 400 pieces of artillery. Although taken by Ferdinand I. in 1527, it successfully withstood the Turks in 1543, 1591, and 1663. Klapka held it for the Hungarians against the Austrians from October 1848 to September 1849.

Kong, a district of West Africa, stretching from 8° 30' to 12° N. lat. along the upper course of the Comoé (mouth at Grand Bassam on the Ivory Coast), and measuring some three degrees of longitude. The district is a plateau, whose average

elevation is 2300 feet above sea-level, rising in a few groups of peaks up to 6000 feet. The Kong Mountains of the geographers are affirmed by Binger to be merely isolated granitic peaks only 300 feet above the plateau. The people, Mandingoes by race and Mohammedans by religion, manufacture cotton stuffs and carry on indigo-dyeing. The capital of the state is the town of Kong, with from 12,000 to 15,000 inhabitants. This district was declared a protectorate of France in 1889. See *Bull. Soc. Geog. de Paris* (1889) for a paper by Captain Binger.

Konich, or KONIYA. See KONIUM.

König, FRIEDRICH, the inventor of the steam-press, was born at Eisleben, 17th April 1774. He became a printer, and at the same time eagerly prosecuted scientific studies. Having devoted himself to the invention of means of printing by machinery, he applied in vain for the necessary pecuniary assistance in various quarters, his schemes being rejected as impracticable; but at last Thomas Bensley, a printer in London, came forward to his support, and a patent was obtained in 1810 for a press which printed like the hand-press by two flat plates. A second patent was obtained in 1811 for a cylinder-press, and others in 1813 and 1814 for improvements upon it. This improved machine was adopted in 1814 by the proprietors of the *Times*. In the later part of his life König was a partner in a company for making steam printing-presses at Oberzell, near Würzburg, in Bavaria. He died 17th January 1833. See PRINTING, and Gobel's monograph (Stutt. 1883; Fr. trans. Paris, 1885).

Königgrätz, a town of Bohemia, on the Elbe, 73 miles by rail E. by N. from Prague. It is the seat of a bishop, and has a Gothic cathedral. The fortifications erected in 1780-89 have been recently razed. Here Ziska was buried in 1424. Pop. (1890) 7815; with its four suburbs, 16,500. A signal victory was gained here by 240,000 Prussians over 220,000 Austrians on 3d July 1866. The Prussian loss was 9000 men, the Austrian 21,000, with 22,000 prisoners. The Austrians name the battle *Sadowa* from an adjoining village nearer the centre of the battlefield.

Königsberg, a town and fortress in East Prussia, situated on the river Pregel, 4½ miles from the Frisches Haff and 366 by rail NE. from Berlin. The original nucleus of the place was the block-house built in 1255 by the Knights of the Teutonic Order, but, although founded so long ago, Königsberg is a modern town; scarce any of its old buildings now exist. The castle, which grew out of the block-house, belongs chiefly to the 16th and 18th centuries. It was the headquarters of the grandmaster of the Teutonic Order, and from 1525 to 1618 was the residence of the Dukes of Prussia. In the castle chapel (built in 1592) Frederick I. crowned himself first king of Prussia in 1701, and William I. was crowned in 1861. The cathedral, now the Knopfdorf parish church, is a Gothic structure, erected in 1333 and thoroughly restored in 1856; in an adjoining building Kant (q.v.) lies buried. The university was founded as a Lutheran institution in 1544, and rebuilt in 1844-65. Connected with it are an observatory (1811), a zoological museum (1819), a botanical garden (1809), a library of 200,000 volumes, together with the usual laboratories and collections. The number of official teachers was 96 and the number of students 760 in 1889. One of the most imposing edifices in the town is the new exchange (1875). The academy of painting, a music school, and a commercial school may be mentioned. Of the industries the foremost place belongs to the iron-works, casting and machinery-making; next come

the manufacture of pianos, thread, tobacco, beer, the confection marchpane, &c. Printing and the preparation of meerschaum (175 tons annually) are also prosecuted. Königsberg is one of the chief continental centres for the tea trade, and ships immense quantities of corn. The exports average in value £8,118,670 annually, and consist mostly of grain, flax, and hemp, with smaller quantities of timber, wool, spirits, sugar, and rags; the imports average £10,117,800, and embrace, besides grain, flax, and hemp for transport, tea, woven goods, metal wares, herrings, timber, chemicals, and coals. Large merchant-vessels which cannot approach the town unload and load at Pillau, 28½ miles by rail to the west, at the entrance from the Baltic to the Frisches Haff. It is proposed to construct a channel through the lagoon (*haff*), with a depth of 20 feet, from Pillau to Königsberg. Pop. (1875) 122,636; (1890) 161,666. The town was first fortified in 1626; but was converted into a modern fortress of the first class in 1843 and since. Königsberg was occupied by the Russians in 1758 and by the French in 1807. See works by Faber (1849) and Schubert (1855).

Königshütte, a rapidly growing centre of great coal, iron, zinc, and copper works in Prussian Silesia, 110 miles SE. of Breslau by rail. It was constituted a town in 1869, out of several mining villages. Pop. (1885) 32,072; (1891) 36,502.

Königsmark, COUNT PHILIPP CHRISTOPH VON, a Swede by birth, born about 1662, who, having entered the service of the Elector of Hanover, was accused of carrying on a love intrigue with Sophia Dorothea, wife of the Elector George, afterwards George I. of England, and suddenly disappeared on 1st July 1694. It is believed that he was murdered. Sophia was confined in the castle of Ahlden until her death in 1726. See a *Quarterly* article (1885); Vizetelly, *Count Königsmark* (1890); and Wilkin's *Love of an Unconquered Queen* (1900). —MARIE AURORA, Countess of Königsmark, sister of Count Philipp, born at Stade in 1670, became in 1694 the mistress of Augustus II., Elector of Saxony, and by him mother of the celebrated Marshal Saxe (q.v.). When Augustus grew tired of her she entered Quedlinburg nunnery, and died prioress of it, 16th February 1728.

Königstein, a fortress of Saxony, once regarded as impregnable, but now of no military importance, stands on a rock 800 feet above the Elbe, 24 miles SE. of Dresden by rail. Here the Saxon army yielded to Frederick the Great in 1756.

Königswart, a town of Bohemia, 14 miles by rail SE. from Eger, is situated in a romantic valley, has a fine castle belonging to Prince Metternich, chalybeate and acidulated springs, and a bathing establishment. Pop. 2112.

Konkan, the name given to the strip of coast-districts in Bombay Presidency. The breadth varies from 1 to 50 miles, as the Western Ghats approach or recede from the sea. Konkan is rather a geographical than an administrative division, and includes, besides North Kanara, the British districts of Ratnagiri, Kolaba, and Thana, Bombay Island, three native states, and Goa, with a total area of 17,000 square miles, and a population of 5,000,000. The annual rainfall is over 100 inches.

Konrad. See CONRAD.

Koodoo. See ANTELOPE, ELAND.

Kootenay, a river of British Columbia which rises in Canada, passes through corners of Montana and Idaho, but returns to Canada again, and, after a course of 150 miles (during which it forms a lake), falls into the Columbia River. Gold is largely found in its basin, especially since 1894, and several mining towns have sprung up.

Kopeck, a Russian bronze coin, the hundredth part of a Rouble (q.v.), and equivalent to $\frac{1}{2}$ farthing of sterling money.

Kopparberg. See FALUN.

Korais. See CORAIS.

Korán (Arab., from *karua*, 'to read'), *The Reading*, by way of eminence; a term first applied to every single portion of Mohammed's 'Revelations,' used at a later period for a greater number of these, and finally for their whole body, gathered together into the one book which forms the religious, social, civil, commercial, military, and legal code of Islam. The Korán is also known under the name of Furgán ('discrimination,' 'test'); further, of *Al Moshaf* (*The Volume*), or *Al-Kitáb* (*The Book*, in the sense of 'Bible'), or *Al Dhikr* ('the Reminder,' or 'the Admonition'). The Korán is, according to the Moslem creed, coeval with God, uncreated, eternal. Its first transcript was written from the beginning in rays of light upon a gigantic tablet resting by the throne of the Almighty; and upon this tablet are also found the divine decrees relating to things past and future. A copy of it, in a book bound in white silk, jewels, and gold, was brought down to the lowest heaven by the angel Gabriel, in the blissful and mysterious 'night of power or destiny,' in the month of Ramadan. Portions of it were, during a space of twenty-three years, communicated to Mohammed, both at Mecca and Medina, either by Gabriel in human shape, 'with the sound of bells,' or through inspirations from the Holy Ghost 'in the Prophet's breast,' or by God himself, 'veiled and unveiled, in waking or in the dreams of night.' Traditions vary with respect to the length of the individual portions revealed at a time, between single letters, verses, and entire chapters or Surahs (Arab., 'courses,' as of bricks in a wall). The first revelation forms, in the present arrangement of the book, verses 1-5 of surah xvi., and begins with the words: 'Read [preach], in the name of thy Lord, who has created all things!'

Mohammed dictated many of his inspirations to a scribe, in broken verses or in finished chapters, and from this copy the followers of the Prophet procured other copies—unless they preferred learning the oracles by heart from the master's own mouth. The original fragments were without any attempt at a chronological or other arrangement, promiscuously thrown into a box, and a certain number were entirely lost. A year after the death of Mohammed the scattered portions were, at the instance of Abu bekir, collected by Zaid Ibn Thábit of Medina, the Prophet's amanuensis, 'from palm leaves, skins, blade-bones, and the breasts of men,' and faithfully copied, without the slightest attempt at moulding them into shape or sequence, together with all the variants, the repetitions, and the gaps. This volume was entrusted to the keeping of Hafsa, one of the Prophet's wives, the daughter of Omar. A second redaction was instituted in the thirtieth year of the Hegira, by Calif Othman, to fix the text and the reading according to the Qoráish idiom; many different readings being current among the believers. He ordered new copies to be made from the original fragments, in which all the variants were to be expunged, but without any further alteration being introduced; and the old copies were all consigned to the flames. With respect to the succession of the single chapters, 114 in number, no attempt was made at establishing continuity, but they were placed side by side according to their respective lengths; so that immediately after the introductory fátah or exordium follows the longest chapter, and the others are ranged after it in decreasing size. They are not numbered in the

manuscripts, but bear distinctive, often strange-sounding headings, as the Cow, Congealed Blood, the Fig, the Star, the Towers, Saba, the Poets, &c., taken from a particular matter or person treated of in the respective chapters. Every chapter or surah but one begins with the introductory formula: 'In the name of God, the Merciful, the Compassionate.' It is generally stated at the beginning whether the surah was revealed at Mecca or at Medina. Every chapter is subdivided into smaller portions (*Ajál*, 'verses,' lit. 'signs'), varying in the ancient 'seven editions' or primitive copies (of Medina [two], Mecca, Kufa, Basra, Syria, and the 'Vulgar Edition' reduced by Noldeke to four editions) between 6000 and 6036. The number of words in the whole book is 77,639, and an enumeration of the letters shows 323,015 of these. Other—encyclical—divisions of the book are into thirty *ajzâ* and into sixty *ahzâb*, for the use of devotional readings in and out of the mosque. Twenty-nine surahs commence with certain letters of the alphabet, 'of which God alone knows the meaning.'

The contents of the Korán as the basis of Mohammedanism will be considered under that head, while for other questions of authorship and chronology we must refer to MOHAMMED. But the chief doctrines laid down in the book are that there is one God, one true religion, and a day of judgment. When mankind turned at different times from truth, God sent prophets to lead them back to it, Moses, Christ, and Mohammed being the most distinguished. Both punishments for the sinner and rewards for the pious are depicted with great diffuseness, and exemplified chiefly by stories taken from the Bible, the Apocryphal writings, and the Midrash. Special laws and directions, admonitions to moral and divine virtues, more particularly to a complete and unconditional resignation to God's will ('Islam'), legends, principally relating to the patriarchs, and, almost without exception, borrowed from the Jewish writings, form the bulk of the book, which throughout bears the most palpable traces of Jewish influence. The Hebrew scriptures were known to Mohammed by oral communication only; hence frequently odd confusion in stories taken from that source.

The general tendency and aim of the Korán is found pretty clearly indicated in the beginning of the second chapter: 'This is the book in which there is no doubt; a guidance for the pious, who believe in the *mysteries of faith*, who perform their *prayers*, give *alms* from what we have bestowed upon them, who believe in the *revelation* which we made unto thee, which was sent down to the *prophets before thee*, and who believe in the *future life*,' &c. To unite into one the three principal religions which he found in his country—Judaism, Christianity, and Heathenism—was Mohammed's ideal; and the Korán, properly read, discloses constantly the alternate flatteries and threats aimed at each of the three parties. Certain abrogations made by the Prophet himself of special passages in the Korán are due to the vacillating relation in which he at first stood to the different creeds, to concessions first made and then revoked. Witness the 'Kiblah,' or the place where the believer was to turn in his prayer, being at first Jerusalem; and also forbearance to idolaters forming one of the original precepts.

The Korán expresses the thoughts and ideas of a Bedawi Arab in Bedawi language and metaphor. In the matter there is endless repetition, little order or coherence, and not a little inconsistency. The style is very unequal; often noble and forcible, often familiar or dull. Accepted as the miraculous utterance of the Almighty, the Korán stands above criticism, and is not proved but assumed to be the

unapproachable standard of grammatical and every other merit. It is written in prose wherein the links of each sentence rhyme with one another, and generally the same rhyme is maintained through the whole chapter. This is and was a common literary form, and to it the Arabic language by its symmetrical formation of words lends itself very readily. Refrains are introduced in some surahs; and plays upon words are not disclaimed.

The outward reverence in which the Koran is held throughout Islam is exceedingly great. It is never held below the girdle, never touched without previous purification; and an injunction to that effect is generally found on the cover which, in the eastern binding, overlaps the boards. It is consulted on weighty matters; sentences from it are inscribed on banners, doors, and the like. Great lavishness is displayed upon the material and the binding of the sacred volume; the copies for the wealthy are sometimes written in gold, and the covers blaze with gold and precious stones. Nor is anything more hateful in the eyes of a Moslem than to see the book in the hands of an unbeliever.

The Koran has been commented upon so often that the names of the commentators alone would fill volumes. Thus, the library of Tripoli, in Syria, is reported to have once contained no less than 20,000 different commentaries. The most renowned are those of Samachshari (died 539 H.), Baidhawi (died 685 or 716 H.), Mahalli (died 870 H.), and Soyuti (died 911 H.). The principal editions are those of Hinckelmann (Hamburg, 1694), Marracci (Padua, 1698), Fingel (1834), besides many editions of small critical value printed in St. Petersburg, Kasan, Teheran, Calcutta, Cawnpore, Serampore, &c. The first, but very imperfect, Latin version of the Koran was made by Robertus Retensis, an Englishman, in 1143 (ed. Basel, 1545). The principal translations are: into Latin, that of Marracci (1698); into English, Sale (1734; ed. by Rev. E. M. Wherry, 4 vols. 1882-86), who explains somewhat while he translates, and whose notes are voluminous and invaluable, Rodwell (1861; 2d ed. 1878), and Palmer (1880), whose rendering is the best; into French, Savary (1783), Garcin de Passy (1829), Kazimirski (1849; new ed. 1884); into German, Megerlin (1772), Waid (1828), Ulbrann (1840); besides Persian, Turkish, Malay, Hindustani, and other eastern translations. Of concordances to the Koran may be mentioned those of Fluzel (1842) and Kazem-Bek (St. Petersburg, 1859), and that published at Calcutta in 1811. Among authorities whose works may be consulted on the Koran are Marracci, Sale, Savary, Waid, Geiger, Amiri, Sprenger, Lane, Muir, Weil, Noldeke, and Lane Poole.

Kordofan, or the White Land, lately a province of the Egyptian Soudan (q.v.), is separated from Senaar on the E. by the White Nile, and from Dar Fur on the W. by a strip of desert. It extends from 12 to 16° N. lat. and from 29° 30' to 32° 30' E. long.; its area, including Takalla on the S., has been estimated at 41,500 sq. m., and its population at 280,000, of whom three-fourths are slaves. The province is traversed by no rivers; but water is found almost everywhere at a comparatively short depth. The surface is undulating. The chief produce of the soil is millet, the principal food of the inhabitants. Gum trees, mimosa, thorny plants, and prickly grass are common, but there is no forest timber. Gums, hides, ivory, ostrich-feathers, and gold are exported. Cattle and camels are bred in great numbers. Three-fifths of the population are settled; the rest are nomadic. The aborigines belong mainly to the Nuba stock, but use a negro tongue and are mostly pagans. There is a large element of nomad and slave-hunting Arabs, Moslems in faith. The capital is El Obeid, with about 30,000 inhabitants, situated in the centre of the country. In the end of the 18th century Kordofan was conquered by the ruler of Senaar, then by the sultan of Dar Fur; in 1821 it was annexed by Mehemet Ali of Egypt, but was

lost to the Egyptians by the Mahdi's revolt in 1883. Since 1899 it has been part of the reconstituted Egyptian Soudan (see SOUDAN).

Korea. See COREA.

Körner, KARL THEODOR, a patriotic German poet, the son of Schiller's friend, Christian G. Körner, was born at Dresden, 23d September 1791. After irregular studies at Freiberg, Leipzig, and Berlin, young Körner, through Kotzebue's influence, was appointed dramatist to a Vienna theatre; for it he wrote some light comedies, such as *Der Grane Domino* and *Der Nachtwächter*, and some tragedies, of which *Zring*, a work full of noble enthusiasm, was the most successful. The uprising of the German nation against Napoleon inspired Körner with patriotic ardour. He joined Lutzow's celebrated corps, and not only displayed heroic personal courage in many encounters, but encouraged his comrades by fiery patriotic songs. These, published in 1814 under the title of *Lyre und Schwert* (Eng. trans. *Lyre and Sword*, 1839), are regarded by the Germans with a kind of sacred admiration, and have gone through a great number of editions. The most famous of these pieces is the *Schwert-Lied*, composed in a pause of battle, and only a few hours before the author fell in a skirmish, between Schwerin and Gadebusch, on 26th August 1813. He was buried near Wobelin; there his father and mother and sister were also interred. A collected edition of his works in one volume (Berlin, 1834; new ed. 1879) was published by Streeckfuss. A biography of the poet, written by his father, has been translated into English, 'with selections from his poems, tales, and dramas,' by G. F. Richardson (Lond. 2 vols. 1845). A museum of Körneriana was formed at Dresden in 1873. See LIVES by Lehmann (1819), Eichard (1821), and Bauer (1883); also Jonas' life of his father (1881).

Körös, NAGY ('Great Körös'), a town of Hungary, 55 miles SE. of Budapest by rail. Pop. (1891) 25,484. KISS KÖROS ('Little Körös'), a small town, 66 miles by rail S. by E. of Budapest, is the birthplace of Petöfi. Pop. 6734. Both places grow wine. See CSOMA DE KÖROS.

Korosko, a small village of Lower Nubia, with a few wretched huts straggling along the right bank of the Nile, about midway between the first and second cataracts. Here the Nile boats land the goods that are conveyed by caravan to the Soudan.

Korveii. See CORVEL.

Kosciusko (KOSCIUSZKO), TADEUSZ, a Polish general and patriot, was born on 12th February 1746 in Lithuania. He chose the career of arms, and was trained in France. In 1777 an unhappy love affair drove him to the United States, where he fought for the colonists and advanced to the rank of brigadier general. He returned to Poland in 1786. When Russia attacked his country in 1792, Kosciusko held a position at Dubienka for five days with only 4000 men against 18,000 Russians. In spite of this the pusillanimous King Stanislaus submitted to the Empress Catharine, whereupon Kosciusko resigned his command and retired to Leipzig. After the second partition of Poland he put himself at the head of the national movement in Cracow, and was appointed dictator and commander-in-chief (1794). His defeat of a greatly superior force of Russians at Racławice was followed by a rising of the Poles in Warsaw. He established a provisional government, and took the field against the Prussians, but, defeated, fell back upon Warsaw and maintained himself there valiantly, until the approach of two new Russian armies induced him to march to meet them. He was overpowered by superior numbers in the battle

of Maciejowice, 10th October 1794; and, covered with wounds, he himself fell into the hands of his enemies—it is then that De Ségur falsely makes him exclaim, 'Finis Polonia!' Two years later the Emperor Paul restored him to liberty. He spent the remainder of his life chiefly in France, prosecuting agricultural pursuits. When Napoleon, in 1806, formed a plan for the restoration of Poland, Kosciusko refused to lend himself to the French monarch's designs. The address to the Poles, which Napoleon published in Kosciusko's name in the *Mondeur*, was a fabrication. In 1814 he besought the Emperor Alexander to grant an amnesty to the Poles in foreign countries, and to make himself constitutional king of Poland. He settled at Solothurn in Switzerland in 1816, and died on 15th October 1817, by the fall of his horse over a precipice. His remains were removed to Cracow (q.v.) by the Emperor Alexander, and were laid side by side with those of John Sobieski. See the biographies by Falkenstein (2d ed. 1834), Chodzko (1837), and Michelet (in *La Pologne Martyr*, 1863).

Kosher (Heb., 'right,' from *gashar*, 'to be right'), pure, according to the Jewish ordinances. Thus 'Kosher meat' is meat killed and prepared by Jews after the Jewish manner, and so fit to be eaten by Jews.

Köslin, a town of Prussia, 5 miles from the Baltic Sea and 85 N.E. from Stettin. There are iron-foundries and manufactures of paper, soap, bricks, &c. It formerly had a mint. Pop. (1885) 17,277.

Kosovo, the 'Field of Blackbirds,' a plain in Turkey, near the Servian frontier, west of the Prishtina, on which two sanguinary battles were fought—(1) between Sultan Murad I. and the Servians under their Tsar Lazar on 15th June 1389; both sovereigns fell, and the Servians lost their independence in consequence of their defeat; (2) between the great Hungarian general Hunyady and Sultan Murad II., on 17th to 19th October 1448, when the former was defeated. See Madame Mijatovich, *Serbian National Songs about Kossora* (Lond. 1881).

Kossuth, LOUIS, the leader of the Hungarian revolution, was born in 1802 at Monok, in the county of Zemplin, in Hungary. His family was of noble rank, but his parents were poor. He studied law at the Protestant college of Szarospatak, and practised for a time. In 1832 he commenced his political career at the diet of Presburg as the deputy of absent magnates, and as editor of a journal which, owing to the state of the law, was not printed, but transcribed and circulated. The subsequent publication of a lithographed paper led, in May 1837, to Kossuth's imprisonment. He was liberated in 1840, and became the editor of the *Pesti Hirlop*, a newspaper in the modern sense of the word, in which he advocated views too extreme for many of the liberals amongst the nobles, but which took strong hold of the youth of the country. In 1847 he was sent by the county of Pesth as deputy to the diet, and soon became the leader of the opposition. He advocated the emancipation of the peasants, the abolition of all feudal rights and privileges, the freedom of the press, &c., and, after the French revolution of 1848, openly demanded an independent government for Hungary and constitutional government in the Austrian hereditary territories. To his speeches must in great part be ascribed not only the Hungarian revolution, but the insurrection in Vienna in March 1848. On the resignation of the ministry in September 1848 he found himself at the head of the Committee of National Defence, and pro-

secuted with extraordinary energy the measures necessary for carrying on the war. As a reply to an imperial decree, dated 4th March, abolishing the Hungarian constitution, he induced the National Assembly at Debreczin, in April 1849, to declare that the Hapsburg dynasty had forfeited the throne. He was now appointed provisional governor of Hungary; but being disappointed in his hopes for the intervention of the Western Powers, and finding the national cause jeopardised by the interference of Russia, he endeavoured to arouse the people to a more desperate effort. The attempt was vain. Finding that the discussions between himself and Gorgei (q.v.) were damaging the national cause, he resigned his dictatorship in favour of the latter. After the defeat at Temesvar on 9th August 1849 he found himself compelled to flee into Turkey, where he was made a prisoner; but, though his extradition was demanded both by Austria and Russia, the Porte resisted their claims. In September 1851 he was liberated by the influence of England and the United States, and, the Republican government of France refusing him a passage through their territory, he sailed in an American frigate to England, where he was received with every demonstration of public respect and sympathy. In December of the same year he landed in the United States, where he met with a most enthusiastic reception. He returned in June 1852 to England, and there he chiefly resided, until Sardinia and France prepared for war with Austria; when, on condition of something definite being done for Hungarian independence, he proposed to Napoleon to arrange a Hungarian rising against Austria. He secured England's neutrality in the event of the war extending to Hungary. The peace of Villafranca bitterly disappointed Kossuth, but did not dishearten him. He made two other attempts (in 1860-61, in conjunction with Cavour and with the help of Napoleon; in 1866, with the aid of Victor Emmanuel) to bring about a rising against Austrian rule in his native country, but without final success. When in 1867 Deak effected the reconciliation of Hungary with the dynasty, and initiated a *modus vivendi* between the two parts of the Austro-Hungarian monarchy, Kossuth retired from active political life. He afterwards lived mostly in Turin, and, although never tired of denouncing the political and economical alliance between Hungary and Austria, abstained from conspiring or agitating against it; but he refused to avail himself of the general amnesty (1867), and to return to his native land to take the oath of fealty to the dynasty he had once dethroned. In 1880-82 he published three volumes of *Memories of my Exile* (Eng. ed. vol. i. 1880); others followed in 1890. He died in Turin, 20th March 1894, and on 1st April was buried amidst national solemnities in the Protestant church at Budapest. See his letters (1862 and 1872), and works on him (in German) by Houm (1851), Frei (1849), and Somogyi (1891).

Kostendil, or KÜSTENDIL, a town of Bulgaria, near the Struma or Strymon, 43 miles SW. of Sofia, has gold and silver mining, warm baths, numerous ruins, and a Greek archbishop. Pop. 11,383.

Kostroma, capital of a Russian government, stands near the junction of the Kostroma with the Volga, 216 miles by rail N.N.E. from Moscow. Of late years the industry of the town has shown great advances. The spinning and weaving of cotton and linen, the manufacture of brandy, dyeing, corn-grinding, and tanning are the chief industries. Pop. (1891) 28,143. The government of Kostroma has on the west the government of Yaroslaff and on the east that of Vyatka. Area, 32,490 sq. m.; pop. (1897) 1,428,893.

Kotah, the chief town of a native state of the same name in Rajputana, standing on the right bank of the Chambal, is a hot, unhealthy city, with a pop. of 40,270. The area of the state is 3803 sq. m.; pop. (1891) 526,267.

Köthen, a town in the German duchy of Anhalt, down to 1853 capital of the principality of Anhalt-Köthen, stands by rail 22 miles N. from Halle and 31 SSE. from Magdeburg. The castle of the former dukes (the line became extinct in 1847) was rebuilt in 1597-1606 after a fire. In the cathedral of St James there are some antique glass windows. The industries embrace iron-foundries, sugar-factories, &c. Pop. (1875) 14,403; (1885) 17,473.

Kotow, the ceremony of prostration, with striking of the forehead on the ground nine times, performed before the emperor of China. The British envoy, Lord Amherst, in 1816 refused to perform the degrading ceremony, and the point was finally conceded by the Chinese in the treaty of 1857. Kotowing is unknown outside of China.

Kotzebue, AUGUST FRIEDRICH FERDINAND VON, a German dramatist, was born at Weimar on 3d May 1761, filled various offices in the public service of Russia, and from an early age was a facile writer of plays, tales, satires, historical works, &c.; he was stabbed to death at Mannheim, 23d March 1819, by Sand, a Jena student, because he had ridiculed the *Burschenschaft* movement. Besides quarrelling with Goethe, Kotzebue satirised the leaders of the Romantic school. Among his dramatic performances, the chief merit of which consists in their knowledge of stage-effect, their lively dialogue, and clever but superficial character drawing, may be mentioned *Menschenhass und Renc* (known on the English stage as *The Stranger*), *Die Hussiten vor Nannburg*, *Die beiden Klingsberge*, *Der arme Poet*, *Armut und Edelstein*, *Die Kreuzfahrer*, *Ostaria*, &c. Kotzebue wrote no fewer than two hundred dramatic pieces, which have been collected in editions of 28 (1797-1823) and of 44 vols. (1827-29).—His son, OTTO VON KOTZEBUE, born on 30th December 1787 at Revel, accompanied Krusenstern round the world in 1803-6, and afterwards made two long voyages of exploration in the Pacific, discovering amongst others the Krusenstern Islands, Kotzebue Sound, and the Suwaroff Islands during his first voyage (1815-17); during the second expedition (1823-26) he visited the Samoa group, the Philippines, the Sandwich Islands, &c. He died at Revel on 15th February 1846. His two books, descriptive of his voyages, were both translated into English (1821 and 1830).

Koumiss is an intoxicating beverage made by the Kalmecks from fermented mares' milk; and artificial koumiss made of ass's and cow's milk has been used in cases of consumption.

Kowalevsky, ALEXANDER, embryologist, was born 19th November 1840, and became professor at St Petersburg. He is known for his researches on the embryology of invertebrates which led to Haeckel's Gastræa theory; for his discovery of the life-history and true position of the Ascidiæ; and for investigations of the development of the Amphioxus, Balanoglossus, Sagitta, and Brachiopods. See ASCIDIANS, EMBRYOLOGY. His brother, WOLDEMAR (1843-83), professor of Palæontology at Moscow, became bankrupt, and died by his own hand.—Woldemar's wife, SONJA or SOPHIE (1850-91), daughter of a Moscow artillery officer, made a brilliant name for herself throughout Europe as a mathematician, was professor of Mathematics at Stockholm, and left a brilliant series of novels, of which *Tora Borevitzova* was translated in 1895. See Löffler's monograph on her (trans. 1895).

Kovno, capital of the Russian government of Kovno, stands near the confluence of the Vilia and the Niemen, 523 miles by rail SW. of St Petersburg and 94 ENE. of Königsberg. The town, founded in the 11th century, was made a stronghold of the Teutonic knights. Long the chief commercial town of Lithuania, it had lost nearly all its trade when it was annexed by Russia in 1795; but since the construction of the railway it has recovered its commercial importance. Grain, flax, linseed, rags, and timber are exported. Pop. 73,543, about one-half Jews.—The government of Kovno touches Prussia and Poland. Area, 15,600 sq. m.; pop. (1897) 1,549,972, of whom three-fourths are Lithuanians and 14 per cent. Jews.

Kowloon, the Chinese peninsula opposite Hong-kong (q.v.), of which 2½ miles were ceded to Britain in 1861, and nearly 200 square miles additional were granted by China to Britain on lease for ninety-nine years from 1898.

Koyumjik. See ASSYRIA, NINEVEH.

Kozlof, a town in the Russian government of Tamboff, is the meeting-place of the railways from the Caspian, the Sea of Azov, and Moscow (123 miles NW.). Pop. 28,350.

Kra, or KRAO, the isthmus connecting Siam with the Malay Peninsula, whose minimum breadth is 44 miles. Most of the schemes for a ship-canal propose to utilise the estuary of the Pakshau, which separates British from Siamese territory, and penetrates 17 miles inland. A ridge of land 7½ miles wide and 250 feet high is all that then separates the Pakshau from the headwaters of the Chumpon, which flows eastwards to the Gulf of Siam. A canal here would shorten the journey from Ceylon to Hong-Kong by 300 miles, and that from Calcutta to Hong-Kong by 540 miles. A railway across the same narrow belt of land has also been suggested. See Loftus, *Journey across the Isthmus of Kra* (1883).

Kragujevatz, a town of Servia, 61 miles S. of Belgrade, has an arsenal, a cannon-foundry, and a small-arms factory. Till 1842 it was the residence of the Servian princes. Pop. (1895) 13,500.

Krain. See CARNIOLA.

Krajova, a town of Roumania, 154 miles by rail W. of Bucharest. In the neighbourhood are productive salt-mines. Pop. 33,000, mostly engaged in commerce. Here the woiwode of Wallachia defeated Sultan Bajazet in 1397.

Krakatoa, or KRAKATAU, a volcanic island in the Strait of Sunda, between Java and Sumatra, was in 1883 the scene of one of the most tremendous volcanic disturbances on record. From May the volcano on the island had been ejecting its contents in showers of ashes; during 26th, 27th, and 28th August the crater walls fell in, together with a part of the ocean bed, carrying with it two-thirds of the island (total area before the eruption 13 sq. m.), and creating two small islands, which subsequently disappeared. At the same time a gigantic ocean wave inundated the adjoining coasts of Java and Sumatra, causing a loss of 36,500 lives, and the destruction of 300 villages, and then curved round the entire globe. The noise of the eruption was heard for a distance of 2000 and even 3000 miles. The occurrence likewise set up a series of concentric atmospheric waves, which travelled at least three times round the earth. The dust and other finely-comminuted debris cast up by the explosion gave rise during three years or more to weird sun-glowings of wondrous beauty, these seen in Great Britain in November 1883 being especially grand. See E. Metzger in *Petersmann's Mittheilungen* (1886); *Report of the Krakatoa Committee of the*

Round Society (Lond. 1888); and G. J. Symons, *The Eruption of Krakatoa* (1888).

Kraken, a fabulous animal, first described by the Norwegian bishop Pontoppidan in 1750, and from time to time said to have been seen in the Norwegian seas. Its back is described as about a mile and a half in circumference; it rises from the sea like an island, stretches out mast-like arms, capable of dragging down the largest ships, and when it sinks again into the deep causes a whirlpool in which large vessels are involved to their destruction. It makes the waters round it thick and turbid, and thus is able to devour the shoals of fishes that swim to the place attracted by the musky scent. This fact, together with its numerous arms, point to one or other of the large class of cuttle-fishes as the true original of the Scandinavian kraken. The fable of the kraken has considerable analogy to the more recent stories of the great sea-serpent. See John Gibson's *Monsters of the Sea* (1887).

Krameria. See RATTANY ROOT.

Kranach. See CRANACH.

Krangannur. See CRANGANORE.

Krapotkin. See KROPOTKINE.

Krasnovodsk, a Russian military station and harbour, on the east side of the Caspian Sea, in the Transcaspian territory. Pop. 427.

Krasnoyarsk, the chief town of the Siberian government of Yeniseisk, on the Upper Yenisei, 370 miles E. from Tomsk, is the centre of the gold-washings of the province. Pop. (1871) 12,974; (1894) 17,154.

Kraszewski, Krazinski. See POLAND (LITERATURE OF).

Krause, KARL CHRISTIAN FRIEDRICH, a German philosopher, born 6th May 1781 at Eisenberg, studied philosophy at Jena under Fichte and Schelling, qualified as a *privat-docent* in that university in 1802, but removed in 1805 to Dresden, where he lived till 1813. His learned work on the doctrines of Freemasonry (1810), advocating their rational reform, drew upon him the resentment of the German Freemasons. After residing for a time in Berlin, lecturing in the university, he settled in Göttingen, where he lectured on all the branches of philosophy (1823-30), and drew around him a number of enthusiastic disciples, including the philosophical jurist, H. Ahrens. He never obtained a professorship, notwithstanding his success and popularity as a *docent*, his incessant industry, and the versatility and fertility of his genius. In 1831, after an amelioration in his circumstances, he removed to Munich, where Baader befriended him, but Schelling treated him with coldness, and in the midst of further disappointments and struggles, he suddenly died there of apoplexy, 27th September 1832. Krause is deservedly ranked with Fichte, Schelling, Hegel, Herbart, and Schopenhauer, as one of the masters of the German philosophical movement inaugurated by Kant. His earlier works (1803-11) are written in an elegant and flowing style, but he limited the circulation and popularity of his later writings by the excessive purism of his German terminology, which eschewed all foreign terms and revelled in the most elaborate native compounds. This literary idiosyncrasy has made Krause for the novice (the most unreadable of all philosophical writers, and even Zeller declares his German to be at times 'as unintelligible to Germans as it were Sanskrit.' The most popular of his writings is his sketch of the Ideal of Humanity (*Das Verbild der Menschheit*, 1812). His system of philosophy is expounded in various sketches and outlines of the philosophical sciences (*Logie*, 1803, 1828; *Ethics*, 1811; *Philosophy of*

Right, 1803, 1828; *Sketch of the System of Philosophy*, 1828), and most fully and definitely in his 'Lectures on the System of Philosophy' (1828) and his 'Lectures on the Fundamental Truths of Science' (1829). Since his death many of his works have been edited by Leonhardi, Ahrens, Roder, Wünsche, and Hohlfeld. The *Ideal of Humanity* has been summarily rendered into Spanish (by Del Rio, 1860) and Italian, and an English translation by Hastic appeared in 1890. Professor Tiberghien of Brussels has ably summarised and illustrated Krause's philosophy in French. Professor Flint has given an admirable summary of Krause's philosophy of history in his *Philosophy of History*, and Professor Lorimer shows appreciation of Krause's philosophy of law in his *Institutes of Law*. The translation of Pleiderer's *Philosophy of Religion* contains a sketch of Krause's Absolute Philosophy of Religion. But Krause's system of philosophy, as a whole, which, as regards his view of the relation of the world to God, he called *Pantheism* ('all-in-God'), in contradistinction to the Pantheism of the other schools and the Dualism of the deistic tradition, has not yet obtained adequate expression in English. Froebel, the founder of the Kindergarten system, followed Krause's doctrines. There are monographs in German by Hohlfeld (1879), Procksch (1880), and Martiu (1881).

Kreasote. See CREASOTE.

Kreatine. See CREATIN.

Krefeld, one of the most important manufacturing towns of Germany, stands about 4 miles from the left bank of the Rhine and 12 NW. of Düsseldorf. It owes its importance to the settlement here, in the 17th and 18th centuries, of refugees from Juliers and Berg, and the neighbouring countries, compelled to leave their homes by religious persecution; they established the silk and velvet manufactures for which Krefeld is now noted. In 1885 the number of looms engaged in these manufactures was 29,837, and the value of the fabrics exported was upwards of £2,975,000. Here are large railway repair shops, iron-foundries, and works for making machinery, and manufactures of chemicals, soap, spirits, &c. The town possesses a technical school of weaving, &c. Pop. (1875) 62,840; (1890) 105,376.

Krementschug, a town of Russia on the Dnieper, 74 miles by rail SW. of Pultowa. From 1765 to 1789 it was the chief town of New Russia; it is now the seat of great industrial activity, especially in wool, timber, and tobacco, and of factories for agricultural machines, leather, tobacco, candles, &c. Pop. (1871) 30,472; (1897) 57,879.

Kremlin. See MOSCOW.

Kremnitz, one of the oldest towns of Hungary, in the county of Bars, lies in a deep, gloomy valley, 83 miles N. from Budapest. It is famous for its gold and silver mines, which, however, are less productive now than formerly, and its mint. Pop. 8,550, almost entirely of German origin.

Krems, a town of Lower Austria, at the confluence of the river Krems with the Danube, 47 miles by rail W. by N. of Vienna. Pop. 11,042.

Kremsier, one of the prettiest towns of Moravia, on the March, 35 miles E. by N. of Brunn. It is the summer residence of the Arch-bishop of Olmutz, whose fine palace contains a picture-gallery, a numismatic collection, and a library of 37,000 volumes. From 22d November 1818 to 7th March 1819 this town was the seat of the Austrian Constitutional Diet. Pop. 12,816.

Kreuzer from the cross (*Kreuz*); formerly conspicuous upon it is a small copper coin still in use in Austria, 100 making a florin or gulden (nominal

value, 2s.). Till 1876 it was current also in southern Germany as the 60th part of a guilder (see FLORIN). The kreuzer was first coined in the 13th century, in Tyrol, and was originally of silver.

Kreuznach, a town of Rhenish Prussia, dating from the 9th century, on the Nahe, 35 miles by rail SSE. of Coblenz. Its chief manufacture is champagne, its principal trade in wine and corn; but it is most notable for its salt springs. These were discovered in 1478, and, being serviceable in serofinous and other affections, attract over 5000 visitors annually. Their temperature ranges from about 50° to 90° F. Pop. (1895) 19,344. See Engelmann's *Waters of Kreuznach* (Lond. 1880).

Kriegsspiel ('war-game') was introduced in 1824 by Lieutenant von Reiszwitz of the Prussian army, after several years spent in perfecting the game as originally designed by his father. It aims at giving interesting representations of military manoeuvres on a contoured map of sufficiently large scale to show all the features of the ground, and enable their effect for cover, command, or concealment to be duly allowed for. The troops are represented by metal blocks coloured red for one player and blue for the other, and made to the same scale as the map. One officer takes command of each side, assisted, if necessary, by subordinate officers. An umpire, with generally two assistants, superintends the game. A 'general idea' of the military situation is issued to each side, and contains whatever information it is considered probable that each would have under the circumstances. A 'special idea' follows, giving such details as the strength and composition of each force, its distribution at the commencement of the game, the immediate object in view, the date and hour of the imaginary time at which operations commence, and any information as to the enemy which may be in the possession of the commander-in-chief, represented by the framer of the scheme. The 'special idea' for one player will differ from that for the other, and must not be seen by him. The wind, weather, state of the country, &c. are usually assumed to be as on the day of playing.

Each player then frames his orders, and is strictly held to them. Three copies of the map are generally used, though one is enough if the players are only allowed access to it in turn when the other's troops are covered up. On 'red's' map, if three are available, only his own troops are shown, until, as the game progresses, it is decided by the umpire that he could see some of 'blue's' men, when pieces representing those only which are so seen are placed on it. 'Blue's' map is similarly treated, but on the third, or umpire's map, both sides are completely represented. The game proceeds by moves, each of two minutes' imaginary time, the space the different arms would cover in that time at ordinary marching rate being laid down on a scale, and thereby transferred to the map. The player points out the direction in which he wishes each body of men moved, and the assistant umpire then measures off the distance and places them. The same number of moves is given simultaneously to both players, and the number of moves given at a time grow less as they come nearer, until perhaps only half a move can be given, or the question arises whether any advance can be made on one side or the other. This and all similar points must either be decided by the umpire from a consideration of the situation, or by a throw of the die. Rules are laid down for the guidance of umpires; thus, 'repulsed' troops cannot come into action again for ten minutes (five moves), 'defeated' troops cannot do so for twenty minutes, and if 'totally defeated' are removed from the map. The victorious side loses half as many as the 're-

pulsed' or 'defeated,' and one-third as many as the 'totally defeated' troops. If the die is used a table of possibility decides such questions as 'can guns come into action under infantry fire,' the odds being 3:2 in favour of the infantry at 500 yards; 2:1 at 400, and so on. These odds also determine the loss per battalion or squadron by means of another table, which allots certain faces of the die to either colour, and regulates the loss in proportion to the number of dots on the face which turns up. Thus, in a question where the odds were 5:4 against 'red,' if the single dot turned up, 'blue' would be 'repulsed' with a loss of six per battalion; if two, three, or four dots turned up, 'red' would be 'defeated' with losses of eight, nine, or eleven per battalion; and if five or six dots turned up, 'totally defeated' with losses of fifteen and eighteen per battalion. Tables of losses from artillery fire and infantry fire at various ranges, and under different conditions are also used, and the time required for destroying or constructing bridges, &c. laid down.

Intelligence of the enemy, if seen by a scout, is obtained from the umpire, who allows himself to be questioned, but frames his answers in accordance with what the scout would be likely to know. Orders sent to detached bodies of troops cannot take effect until sufficient time has elapsed for an orderly to reach them; and, if directed to go across country, at each fence the die must be thrown to decide whether he gets over without a fall. Everything is done to make the conditions of the game similar to those of actual warfare, with the result that the players cannot fail to realise the value of time in military operations, the difficulty of ascertaining the enemy's movements, and the necessity for clear and definite orders. The umpire decides when the game shall cease, which is generally when one side has clearly obtained the mastery or gained his object. See Vernois, *The Tactical War Game* (trans. by Macdonnell, 1884).

Krilof, IVAN ANDREYEVICH, the La Fontaine of Russia, was born at Moscow, February 14, 1768, the son of a penniless infantry captain. At fourteen he lost his father, next filled for some time a post in a public office at St Petersburg, but gave it up after his mother's death in 1788, to try in turn writing dramas, and the joint editing and publishing of literary magazines. For some years he found shelter at the country seats of Prince Sergius Galitzin, acted till 1804 as his secretary when military governor of Livonia, and next wandered aimlessly about the towns of Russia, finding his amusement in card-playing. About the close of the year 1805 at Moscow he showed some of his fables to the poet Dmitrieff, who printed them in the *Moscow Spectator*. They were at once successful, and thus Krilof, at forty, found in what his strength really lay. The first collection of his fables (twenty three in number) appeared in 1809; the second, containing twenty one more, in 1811. He returned to St Petersburg in 1806, and soon after obtained a government appointment which in 1821 he exchanged for a congenial post in the Imperial Public Library under his friend Olenine. Honours were now showered upon his head; his years glided peacefully away; he was comfortably off, and much beloved by all ranks of society, no less for his kindness and good nature than for his carelessness in dress, his laziness, his excessive smoking, and a thousand amiable eccentricities. He died November 21, 1844, and the vast spontaneous concourse at his funeral in the Nevsky Prospect showed how closely he had touched the popular heart of Russia. A fine bronze statue of him was erected in the Summer Garden.

Krilof was careless of time, but could not help being a consummate artist, and the Horatian *curiosa felicitas* is one of the most characteristic

marks of his versification. His shrewd humour and keen though genial satire are all his own, no less than that insight born of sympathy which has given such reality and truth to his glimpses of Russian men and manners. His slightest fables, however light and merely humorous they seem, are stamped throughout by broad humanity and intense although enlightened patriotism. Yet he is never dull or tedious, and his moral never lacks the saving grace of spontaneity. Withal he is a genuine fabulist, with rich measure of that shrewdness wrapped in simplicity, that sense of the varied individuality veiled in the dumbness of the brute-world, and that mastery of the art of compressing the essentials of a story into a few concise and straightforward lines, which mark only the greatest masters of the art.

For Krilof's life may be read the memoirs in Russian by Pletnet and by Grot, the admirable sketch prefixed by the late W. R. S. Ralston to his *Krilof and his Fables*, a prose translation; in its first edition (1868), of ninety-three fables; in its fourth (1883), of fifty-five more. There are good translations into French verse by Charles Parfait (1867); into German by Ferdinand Tornay (1842), and an anonymous lady (1863). See also chap. vi. vol. I of Sutherland Edwards, *The Russians at Home* (1879).

Krimmitschau, a town of Saxony, 45 miles S. of Leipzig by rail, manufactures buckskin and vicuña wool, machinery, &c. Pop. (1875) 17,705; (1885) 19,755; (1895) 23,553.

Kris, a dagger or poniard, the universal weapon of the inhabitants of the Malayan Archipelago.



Malay Kris.

It is made of many different forms, short or long, straight or crooked. The hilt and scabbard are often much ornamented. Men of all ranks wear this weapon, and those of high rank when in full-dress sometimes carry three or four. In Java women sometimes wear it.

Krishna. See VISHNU.

Kronenberg, an iron-manufacturing town of Rhenish Prussia, 4 miles S. of Elberfeld. Pop. 8858.

Kronos. See SATURN.

Kronstadt (Magyar *Beassó*), an important trading and iron-manufacturing town, and capital of a Hungarian county in the extreme south-east of Transylvania; it is 261 miles SE. of Pesth by rail, near the Carpathians, and 1850 feet above the sea. The pop. (30,739 in 1890) includes Saxons, Székler, Magyars, Romanians, Greeks, Armenians, and Gypsies.—For the Russian Kronstadt, see CRONSTADT.

Kroonem, or KROOBOYS (also spelt *Kroonem* and *Krooboy*), a Negro people inhabiting for the most part the Pepper Coast of Guinea, West Africa. They belong to two divisions, the Grebo or Gedeha and the Kroonem proper. The Grebo are agriculturists and traders; the Kroonem are bold and skilful boatmen, and are employed for the sari boats all along the coast of that part of Africa. Their language is closely related to the Mandingo tongue.

Kropotkin, PRINCE PETER, Russian Nihilist, was born at Moscow in 1842, of one of the noblest houses in the empire. At fifteen he entered the Corps of Pages at St. Petersburg, whither, after five years' service and exploration in Siberia, he returned

in 1867 to study mathematics for four years at the university, whilst acting as secretary to the Geographical Society. In 1871 he explored the glacial deposits of Finland and Sweden; in 1872, whilst on a visit to Belgium and Switzerland, he associated himself with the extreme section of the International. Two years after his return to Russia he was arrested (March 1874), but in July 1876 escaped to England. From Switzerland he was expelled in 1881; and at Lyons he was condemned in 1883 to five years' imprisonment. Released in 1886, he returned to England. He is author of *Paroles d'un Révolté* (1885) *In Russian and French Prisons* (1887), *Memoirs of a Revolutionist* (1899), and articles in the *Even. Britannica*, the present work, &c.

Krüdener, BARBARA JULIANA VON (1766-1824), daughter of Baron von Vietinghoff, was born at Riga. Married to Baron von Krüdener, a Livonian nobleman who was Russian ambassador at Venice, she for years lived apart from him in Riga, St. Petersburg, and Paris. In 1803 she published a novel, *Falerie*, edited by Sainte-Beuve in 1855, supposed to be partly autobiographical. Next her thoughts turned to religion. She came in contact with Jung-Stilling, and ultimately gave herself up to exaggerated religious mysticism. She appeared as the herald of a new religious era, and impressed the Emperor Alexander of Russia. Obligated to withdraw from France, she retired to her paternal estates near Riga. See Krug's *Conversations with Madame von Krüdener* (1818), and Lives by Eynard (1819), Lacroix (1880), and Clarence Ford (1893).

Kruger, STEPHANUS JOHANNES PAULUS, born 10th Oct. 1825 at Rastenburg in Cape Colony, with his fellow-Boers 'trekked' to Natal, the Orange River Free State, and the Transvaal, and in the war against England (1881) was appointed head of the government. In 1883 he was elected president of the Transvaal Republic, and again in 1888, 1893, and 1898. On the failure of negotiations to remedy the Outlanders' grievances he, with Mr Steyn, president of the Orange Free State, on 9th Oct. 1899 presented an ultimatum which was virtually a declaration of war, and for which his government had been preparing for years. This was followed by the invasion of Natal and Cape Colony; and the war, which lasted till the end of 1900, resulted in the annexation of the Transvaal and Orange Free State as British colonies. In Nov. 1900 Mr Kruger sought refuge in Europe. See JAMESON (L. S.); and Statham, *Paul Kruger and his Times* (1898).

Krummacher, FRIEDRICH WILHELM (1796-1868), anti-rationalist theologian, born at Mors-on-Rhine, was latterly chaplain to the Prussian court. Translations of his books on *Solomon* and *Elijah the Tishbite* were popular. See his *Autobiography* (1869), and the *Lebenserinnerungen* (1889) of his brother, Emil Wilhelm. His father, Fr. Adolf Krummacher (1768-1845), wrote the well-known *Parabeln*.

Krupp, ALFRED, head of the gigantic iron and steel works at Essen in Prussia, was born in humble circumstances there in 1812. He succeeded his father, who had founded a small iron forge there in 1810, and took control of the works in 1848, when he found 'three workmen and more debts than fortune.' Almost simultaneously with the introduction of the Bessemer steel process in 1857 and the use of the steam-hammer came the demands from artillerists for larger guns, and from railway companies and shipbuilders for more durable materials of construction. Krupp established at Essen the first Bessemer steel works erected in Germany, and the first forging hammer as well. The first steel gun manufactured at Essen (1847) was a 3 pounder muzzle-loader. Krupp showed in

the International Exhibition of 1851 a 6-pounder steel gun. To Krupp undoubtedly belongs the credit of introducing steel as a material for gun construction, and of pioneering that material for many years when it was disregarded by the governments. In 1862 he exhibited a cast-steel block weighing 20 tons, which was designed to show what the Essen works were capable of doing in the manufacture of ordnance. He showed a similar block at Paris of 50 tons (1867), and a block of 52 tons at Vienna in 1873. At the Dusseldorf Exhibition of 1880 he showed a steel gun of 100 tons weight, being the first to demonstrate the possibility of producing a piece of ordnance of such enormous size. The manufacture of cast-steel axles was begun in 1852, and of tires from solid forged pieces in 1853. The subsequent history of the Essen works is an epitome of the records of the German iron and steel industry. In all matters of technical and industrial development Krupp took a leading part. He acquired large mines and collieries, and every year saw additions made to his establishment at Essen (q.v.). The works cover about 1000 acres, and about 20,000 persons find employment there in all departments. Krupp was a man of much decision of character, and great penetration. Naturally Germany owed him much, and was not slow to acknowledge her obligations. The late Emperor William frequently visited him, and it was probably to this circumstance that the popular rumour of his partnership in the works was due. Krupp supplied artillery to almost every government in Europe, and was the recipient of many foreign orders and decorations. He died 14th July 1887, and sixty thousand people attended his funeral.—His son, Alfred, succeeded as head of the great house at Essen; and under him was manufactured in 1888 the 135-ton gun for the fortifications of Cronstadt. See CANNON; and *Alfred Krupp*, by Budeker (Essen, 1888).

Krusenstern, ADAM JOHN, BARON VON, a Russian voyager, was born 8th November 1770 at Haggud in Esthonia. After serving for some time in the British navy he was commissioned by Alexander I. of Russia to command a naval expedition for exploring purposes in the North Pacific. In the course of a three years' voyage (1803-6), the first made round the world by a Russian navigator, he discovered the Orloff Islands, and explored the Marquesas and Washington groups, the west coast of Yezo, the coast of Saghalien, and the northern Kurile Islands. But he failed in the second object for which he was sent out—the opening of Russian trade with Japan. He published an account of his voyage (3 vols. Petersb. 1810-12), which was soon translated into the principal languages of Europe (Eng. ed. 1813); and to this he subsequently added *Contributions to the Hydrography of the Pacific Ocean* (1819), *Atlas of the Pacific Ocean*, with *Recueil des Mémoires Hydrographiques* (1824-27), and other works on the same subject. Krusenstern died on 12th August 1846 at his estate in Esthonia. See *Memoir by Bernhardt* (Eng. trans. by Sir John Ross, 1856).

Krylov. See KRILOF.

Kshatriya. See CASTE.

Kuban, a river of the Caucasus (q.v.), and the name of a province.

Kublai Khan (called by the Chinese CHI-TSU), more properly KHUHLAI KHAN, the Grand Khan of the Mongols and emperor of China, was the grandson of Genghis Khan through his fourth son Tuli. During the reign of his brother Mangu (1251-59) Kublai completed the conquest of the northern Chinese (Kin) empire (begun by Genghis) and took possession of north China. On the death of Mangu, Kublai was proclaimed khakhan or

Great Khan, but had a formidable rival in his own brother Arikhuka, and after he had suppressed him, in Kaidu, a descendant of Genghis Khan's third son Oghotai, who struggled against Kublai throughout the whole of his reign. Kublai, who was an able and energetic prince, adopted the Chinese mode of civilisation, greatly encouraged men of letters, made Buddhism the state religion, creating the office of Great Lama in Tibet, and manifested an enlightened care for the welfare of his subjects. But he was also an ambitious sovereign and a prince who loved magnificence. He overthrew the Sung dynasty of southern China, compelled Corea, Cochinchina (Champa), Burma (Mien), Java, and some Malabar states in India to acknowledge his supremacy. An attempt to invade Japan ended in disaster. He established himself at Tatu or Khan-baligh (Cambaluc, the modern Peking), and there founded a new dynasty—that of Yuen—the first foreign race of kings that ever ruled in China. Including the western Mongol states of the Golden Horde on the Volga and the Ilkhans in Persia, Kublai's dominions extended from the Arctic Ocean to the Strait of Malacca, and from Corea to Asia Minor and the confines of Hungary—an extent of territory the like of which had never before, and has never since, been governed by any one monarch in Asia. The splendour and pomp of his court inspired the graphic pages of Marco Polo (q.v.)—who spent some time at the residence of the Mongol emperor of China—and at a later date the imagination of Coleridge. See Yule's *Marco Polo* (1875), and Howorth's *History of the Mongols* (part i. 1876).

Kuch Behar. See BEHAR.

Kuenen, ABRAHAM, an eminent Dutch theologian, was born at Haarlem, 16th September 1828, studied at Leyden, and became at the close of 1852 an extraordinary, in 1855 an ordinary professor there. He was vector of the university, 1861-62. His first important work was his *Historisch-Critisch Onderzoek naar het Oudsteen en de Verzameling van de Boeken des Ouden Testaments* (3 vols. 1861-65; trans. in part by Colenso, 1865), which had a great influence on Old Testament scholars both in England and Germany. The result of the critical movement which he inaugurated, although it was first suggested by Graf, has been to entirely reconstruct the history of Israel, the priestly code and the historical portions connected with it being made the latest element in the Pentateuch. This view of Old Testament criticism has since been made familiar to Englishmen through the work of Wellhausen and his disciple Robertson Smith, and was developed further by Kuenen in his best-known book, *De Godsdiens van Israel tot den Oudeerping van den Joodschen Staat* (1869-70; Eng. trans. 3 vols. 1873-75), and in the carefully revised and considerably fuller second edition of his *Onderzoek* (the Hexateuch, 1885; the Prophetic books, 1889). In the preface to the latter he says: 'In setting forth, for the first time, the complete and systematic critical justification of the Graham hypothesis, I am no longer advocating a heresy, but am expounding the received view of European critical scholarship.' Other works of Kuenen, only less important than these, are *De Profeten en de Profetie onder Israel* (1875; Eng. trans. 1877) and *National Religions and Universal Religions*, the Hibbert Lectures for 1882. Besides these Kuenen has made countless contributions on biblical questions to the learned journals, especially the well-known *Theologisch Tijdschrift*, established in 1867. He died at Leyden, 10th December 1891. In critical insight and constructive ability, he stood at the head of the Old Testament critics of his time; Ewald's mantle had fallen on him. His firm grasp of historical

method has given an unusual lucidity and force to his argument, and enabled him to bring almost for the first time the history of Israel into line with the history of other peoples of the ancient world. For, leaving the special supernatural question aside, its development must otherwise have been organic and normal, and this Kuenen was the first historian conclusively to demonstrate.

Kuen-Lun, a great mountain-chain of central Asia, which forms the northern wall of the Tibetan plateau, as the Himalayas do the southern. Starting from the Pamir plateau (82° E. long.), the Kuen-Lun extends eastward as far as 94° E. long., forming an arc to the north. The entire region, which varies from 100 to 150 miles in width, is covered with snow, and in many places with gigantic glaciers. Between the chains lie narrow valleys of a very steep inclination. Storms of sand and of snow, often of both commingled, rage violently in winter. The peaks of this region measure from 18,000 to 25,000 feet in altitude, and the passes from 13,000 to 18,000 feet. These mountains were almost unknown until the explorations of the Russian General Prjevalski, 1876-88.

Kufic Coins are the early Mohammedan coins engraved with inscriptions in the Kufic or epigraphic Arabic character, as distinguished from the Neskhi or cursive writing (see ARABIA, Vol. I, p. 367); but the term is often applied erroneously to Arabic coins in general. In the early years of the califate the gold and copper coinage of the Byzantine emperors and the silver coinage of the Sassanians were used and imitated. The Arabic historians refer to several attempts to introduce a distinctive Mohammedan coinage prior to 76 A.H.; but, with the exception of two or three isolated specimens in the Paris Bibliothèque Nationale, on which numismatists are not agreed, there is no numismatic evidence for any such experiments. In 76 and 77 A.H. (695-96 A.D.) the Calif 'Abd el-Melik issued gold coins with his own image instead of that of the Byzantine emperor; but, the representation of living creatures being opposed to the law of Mohammed, this coinage was discontinued, and a reformed gold currency, engraved solely with Kufic inscriptions, was inaugurated in 77 A.H. This was supplemented with a silver currency on similar lines in 79 A.H., and the earliest dated copper coin appeared in 80 A.H. The gold coin was called a *dirham* (from the denarius), the silver a *dirhem* (drachma), and the copper a *folis* (follis). The first weighed on the average 65 grains troy, .979 fine, or rather more than our half-sovereign; the dirhem weighed about 45 grains, .970 fine, or rather more than our sixpence, but was much larger and thinner; the weight of the fels was irregular. The earliest coins present chiefly religious formulas and the year of issue, to which the silver and some of the copper added the name of the mint-city. The names of the califs first appear on gold and silver under the 'Abbāsids; but with this addition, and sometimes the names of governors and viziers, the gold and silver currency of the Moslem empire remained practically unchanged until the 4th century of the Hegira (q.v.; the 10th A.D.), and even then the break-up of the empire of the califs into numerous minor dynasties did not bring with it any more serious modifications in the coinage than the introduction of the names of princes and sultans and some variation in the style of the inscriptions. During the whole of this period the Arabic character on the coins is still almost universally Kufic; but in the 4th century local peculiarities begin to appear, and various styles are developed, which may be termed *transitional Kufic*. Examples of these are seen in the coinage of the Ghaznavids of North-west India, and still more marked in the

issues of North Africa and Spain, such as those of the Fatimi califs. Occasional idiosyncrasies, in the introduction of Roman and Byzantine images, and even of the figures of Christ and the Virgin, are seen on the coins of the Mesopotamian dynasties of Turcoman race in the 6th century of the Hegira (12th A.D.), which also present beautiful examples of highly-decorative transitional Kufic. In the 7th century (13th A.D.) the Kufic was generally superseded by the Neskhi character throughout the coinage of the Mohammedan world, and attained its greatest perfection on the currency of the dynasts of Granada and Fez, the shahs of Persia, and the rulers of Delhi. Mongol and Sanskrit inscriptions are incorporated with Arabic in the legends of coins struck by the descendants of Genghis Khan in Persia and the Indian kings. Kufic coins are of inestimable value to the historian, for they supply him generally with the names of kings, governors, and califs, and those of their liege-lords, heirs-apparent, and viziers, and often a short pedigree of their ancestry, together with the city where they struck the coins, and the year, and sometimes even the month, of issue. A complete list of Mohammedan coins is a skeleton history of the Moslem empire in all its ramifications, and not seldom a prince or dynasty unknown to history is revealed by the coins alone.

The principal modern authorities on the subject are *Soret, Éléments de la Numismatique Musulmane* (1868); *Sauvage, Matériau pour servir à l'histoire de la Numismatique Musulmane* (1885, &c.); *Tieszenhausen, Monnaies des Khalifes Orontours* (1873); *Lavoix, Catalogue des Monnaies Musulmanes de la Bibliothèque Nationale* (vol. i, 1887); *Stieckel, Handbuch zur morgenländischen Münzkunde* (1870); *S. Lane-Poole, Catalogue of the Oriental and Indian Coins in the British Museum* (12 vols, 1875-90); *Catalogue of the Mohammedan Coins in the Bodleian* (1888); *Essays in Oriental Numismatics* (1874 and 1877); *Coins and Medals, their Place in History and Art* (1885); *R. S. Poole, Catalogue of Persian Coins in the British Museum* (1888); and among older works, *Marsden, Numismata Orientalia* (1825; and new ed. 1874, &c.), *Fraehn, Recensio* (1825).

Kugler, FRANZ, a German historian of art, was born at Stettin, January 19, 1808, studied at Berlin and Heidelberg, and in 1833 became a professor in the Academy of Art and a *docent* at the university of Berlin. He died March 18, 1858. His most valuable work is a *Handbuch der Geschichte der Malerei, von Konstantin d. Gr. bis auf die neuere Zeit* (2 vols, 1837). Of this the part relating to Italian art was translated by the Eastlakes (5th ed. 1887), and that relating to the German, Spanish, French, and Dutch schools by Head. Kugler's other principal works are a *Handbuch der Kunstgeschichte* (1841-42), an unfinished *Geschichte der Baukunst* (1855-60), and a *Life of Frederick the Great* (with ill. by Menzel, 1840; new ed. 1887; Eng. trans. 1843 and 1877). He is also favourably known as a poet and as the author of several dramas.

Kuh-horn, ALPENHORN, or ALPHORN, a simple musical instrument made of wood or bark with a cupped mouthpiece, formerly employed by the mountaineers of Switzerland and other countries to convey signals or alarms in war-time, but now only used by cowherds—hence the name. It is variously made from 3 feet to about 8 feet long, nearly straight, curving at the end, and widening into a bell, and has the peculiarly tender sound produced by the cupped mouthpiece in conjunction with the wooden tube. It has the open harmonics of the tube; and its melodies, which among the mountaineers have a charm all their own, are played on the notes C, G, C', E, G'. A similar instrument, called *Lure*, is used in Sweden, and kindred ones in the Himalayas and among the Indians in South America.

Kullenburg. See CULENBORG.

Kuka, or KUKAWA. See BORNÜ.

Ku-Klux Klan, a secret organisation which, said to have been founded in 1866 at Pulaski, Tennessee, originally for purposes of amusement only, soon developed into an association of 'regulators,' and became notorious for the lawless deeds of violence performed in its name. The proceedings of the Ku-Klux in the southern states are only one feature of the determined struggle to withhold from the emancipated slaves the right of voting. The outrages and murders which convulsed the country in 1868-69 ended in the calling out of troops and the formal disbandment of the society in March of the latter year; but its name and often its disguises were used for years after to cover the violence of political desperadoes.

Kulja, a town of Zungaria, central Asia, stands on one of the great highways leading from China to west Turkestan, and on the Ili. This river rises on the northern slope of the Tian-Shan Mountains, and flows north and north-west into Lake Balkhash, after a course of about 750 miles. Kulja is the chief town of a fertile district that produces excellent corn, rice, cotton, tobacco, wine, and fruits, whilst its pastures support large herds of horses, camels, cattle, and sheep. This district (Kulja or Ili) revolted against China in 1865, was occupied by Russia in 1871, but ten years later restored to the Chinese. Russia, however, retained 4357 sq. m. of the western part, now incorporated in the province of Semiryetchensk. The Chinese province has an area of 23,130 sq. m. and a population of 70,000. In 1876 the population of the entire province whilst in Russian hands was 132,000. The town of Kulja has about 12,500, mostly Chinese inhabitants. New Kulja, 25 miles to the west, was destroyed by the rebels in 1866; previous to that date it had 75,000 inhabitants. See *Proc. Roy. Geog. Soc.*, August 1880.

Kulm, a village of Bohemia, 3 miles NE. of Teplitz, was the scene of a bloody conflict between the French and the allied Prussians and Russians on 29th and 30th August 1813. The French, numbering 40,000 men, were commanded by General Vandamme; the Russians, during the first day's conflict, were 15,000 strong, and were commanded by General Ostermann. During the night the latter were heavily reinforced, and on the second day Barclay de Tolly assumed the command. The result was the complete wreck of the French army, which lost in these two days little short of 20,000 men; Vandamme capitulated with 10,000 men.

Kultur-kampf. See GERMANY.

Kum, next to Meshed the most sacred city of Persia, is a straggling, half-ruined, uninviting town on the commercial road between Ispahan and Teheran. Its many shrines and tombs dedicated to Mohammedan (Shiite) saints, especially the reputed tomb of Fatima, the daughter or sister of the great imam Riza, annually attract several thousands of pilgrims. Pop. 20,000.

Kumamoto', a town on the west coast of the island of Kiu sin, Japan. Pop. (1895) 69,828.

Kumania. See CUMANIA.

Kumann, a district in the North-west Provinces of India, with an area of 7000 sq. m. It lies chiefly on the south slope of the Himalayas, and comprises a number of summits rising to over 20,000 feet. At their foot a great waterless forest, 10 to 15 miles in breadth, fills the country with wild jungle, except where clearings have been made by the hill tribes. Mines of iron, copper, and lead exist, but few have yet been worked at all. There are numerous important tea-gardens in the district.

Almora (q.v.) is the administrative headquarters. Pop. (1891) 563,181, nearly all Hindus.

Kumiss. See KOUMISS.

Kümmel. See LIQUEUR.

Kum-quat. See ORANGE.

Kunduz, a river and state of Afghan Turkestan. See AFGHANISTAN.

Kunersdorf, a village in Prussia, 4 miles E. of Frankfort-on-the-Oder, was the scene of one of the most remarkable battles of the Seven Years' War, fought on 12th August 1759, in which Frederick the Great with 48,000 men, after gaining a half victory, was completely defeated by the allied Russians and Austrians, 78,000 men strong. The Prussian loss was 18,500 men, with almost all their artillery and baggage, while their opponents lost 16,000 men.

Kungur, a town in Russia, 50 miles SSE. from Perm, carries on tanning, boot-making, and tallow-boiling. Pop. (1885) 11,882.

Kunigunde, ST. daughter of Count Siegfried of Luxemburg, and wife of Duke Henry of Bavaria, who was crowned king of the Germans in 1002, and emperor in 1014. According to legend, she vindicated her chastity by walking barefoot over hot ploughshares. After her husband's death in 1024 she retired into the convent of Kaufungen, near Cassel, which she had founded, and here she died, 3d March 1030. Pope Innocent III. canonised her in 1200.

Kupferschiefer, one of the series of strata which make up the 'Dyas' type of the Permian System (q.v.) as it is developed in Germany. The bed consists of black bituminous shale, about 2 feet thick, abundantly charged with well-preserved remains of various fish, coniferous leaves, fruits, &c. The organic remains are abundantly coated and even replaced by copper ore (hence the name of the bed), which has been extensively worked along the flanks of the Harz.

Kura, a river of the Caucasus (q.v.).

Kuram, a river rising in Afghanistan near the northern end of the western Suliman range, and flowing through British territory into the Indus near Isakhel. Its valley affords a famous pass into Afghanistan.

Kurdistan ('the Country of the Kurds'), an extensive geographical, though not political, region of Asia, for the most part included within a line drawn from Sivas in Asia Minor by way of Diarbekr, Sulimanieh, Kernanshah and Urmia (in Persia), Mount Ararat, and Erzerüm, back to Sivas. Kurdistan thus belongs to both the Turkish and Persian monarchies, chiefly to the former, and contains about 50,000 sq. m., with a population estimated at more than 2½ millions, thus distributed - nearly 1½ millions in Turkey, 700,000 in Persia, 45,000 in Russian Transcaucasia, and about 5000 on the Afghano-Persian frontier (transplanted thither by Nadir Shah). The country embraces the mountain-chains that alut upon the Armenian plateau on the south, and upon the Iranian plateau on the east. Thus its surface ranges from 5000 up to 15,000 feet in altitude. Between the mountain-chains, the summits of which are generally densely wooded, lie grassy plateaus. Numerous rivers force their way through the mountains at right angles to the directions of their main axes, and go to feed the Tigris and the Euphrates; chief of these tributaries are the two Zabs, the Batman-su, and the two branches of the Euphrates. The principal products of the soil and of native industry are wool, butter, sheep, gum, gall-nuts, hides, raisins, and tobacco, which are sold out of Kurdish districts to the annual value of £110,000. The bulk of the

inhabitants are Kurds (the ancient *Carduchi*), a race partly nomad and pastoral, and partly settled and agricultural. The Kurds, who speak a language called Kermanji, derived from an old Persian dialect, have from time immemorial stood on the same level of civilisation. They are predatory and impatient of political subjection, but recognise a code of rude chivalrous honour, and are hospitable and brave. They live under chiefs of their own, but are nominally subject to the Porte and the Shah of Persia respectively. Their origin is traced back to the Turanian Ginnu or Kurdu, who were a powerful people in Assyrian times. After the fall of Nineveh they gradually became merged in the Medes and were Aryanised. Kurdistan, having been ruled successively by the Persians, Macedonians, Parthians, Sassanians, and Romans, is exceedingly rich in antiquarian remains, most of which are still unexamined. The great Saladin was of Kurdish descent. In 1880 an extensive Kurdish rising against Persia took place, apparently in the hope of securing independence. The inhabitants, with the exception of certain peculiar and esoteric sects, and the Nestorians (q.v.), profess Mohammedanism. They have cruelly plundered and slaughtered their Armenian neighbours. The chief towns are Bitlis, Van, Urmia, Diabekr, and Kermanshah.

See Milligen, *Wild Life among the Kurds* (1870); Lerch, *Forschungen über die Kurden* (St Petersburg, 1857-58); Jaba, *Recueil de Notices et Révélés Kurdes* (1860); and Jaba's *Dictionnaire Kurdo-Français*, with Just's valuable preface (1879).

Kurfürst. See ELECTOR.

Kuria-Muria Islands, a group of five islands, situated 21 miles from the south-east coast of Arabia, in 17° 30' N. lat. and 56° 10' E. long.; area, 21 miles; pop. 34. The ancient *Insula Zenobii*, they were ceded to England in 1854 by the Imam of Muscat. On one of them is a signalling station of the Eastern Telegraphs Company. Guano of an inferior quality is obtained from them.

Kuriles, a sparsely-populated group of islands, numbering twenty-six in all, and extending like a chain from the southern cape of Kamchatka to the eastern extremity of Yezo in Japan, to which empire they belong. By a treaty made with Russia in 1875 the Japanese surrendered claims on the southern part of Saghalien, and received in exchange the more northerly portion of the Kuriles. The largest islands of the group are Iturup and Kunashiri, frequently visited by seal-hunters. A migratory race of pit dwellers, calling themselves Kurilsky Ainos, and numbering about sixty souls, is found on the islands, the remnant of a people which formerly inhabited Yezo (see *Transactions of the Asiatic Society of Japan*, vol. x, p. 190). With the exception of these pit dwellers and a few Japanese and Aino families on the southern isles, the population remains in this misty and inhospitable region only during the summer, as long as the fishing season lasts.

Kurisches Haff, a fresh-water lagoon of East Prussia, extending 61 miles south from Memel; width in the south, 28 miles; average width, 14 miles. It is connected with the Baltic by the 'Memel Deep,' a channel about 500 yards wide and 20 feet deep. The spit of sand dunes, one to two miles wide, that separates it from the Baltic, is encroaching on the haff at the rate of eighteen feet annually.

Kurland. See COURLAND.

Kurrachee (*Karachi*), the capital of Sind and of Kurrachee district, and the chief port of entry for the Punjab, stands at the northern end of the great Indus delta, and close to the frontier of Beluchistan. It is a terminus of the Sind, Punjab, and Delhi Railway, and is 1169 miles by rail (about

half that distance direct) SW. of Delhi. Kurrachee has an extensive harbour, sheltered by a break-water and a long reef, at the extremity of which is a fixed light 120 feet above the sea. The landing-place is on Kiamari Island, which is connected with the town by the Napier mole, 3 miles long. The entire cost of the great harbour improvements, completed in 1873, was £450,000; and there is now a lowest depth over the bar of 20 feet. Kurrachee is a modern town, and its public buildings and churches are generally uninteresting, the most attractive being the Frere municipal hall (with a library and museum), named after Sir Bartle Frere (q.v.), of whom there is also a statue here. To the east and north are the cantonments, and, close by, a public garden of 40 acres. The place is generally healthy, and not so hot as the inland districts of Sind; and there is now a good water-supply. There are ironworks and several large cotton presses in the town, the cotton of Sind and the Punjab forming an important article of export. The principal exports, however, are wheat and oil-seeds. The annual trade of the port has risen to above £7,000,000; the inland trade extends to Afghanistan and Beluchistan. Pop. (1881) 73,560; (1891) 105,109, with the cantonments.—Kurrachee district has an area of 14,115 sq. m.; pop. 560,880, mostly Mohammedans. See Baillie, *Kurrachee, Past, Present, and Future* (1890).

Kursk, the chief town of the Russian government of Kursk, 312 miles by rail S. by W. of Moscow and 274 NNE. of Kieff. The chief industry is tanning; but soap, tobacco, candles, and spirits are also manufactured. Kursk is celebrated for its orchards, and has an observatory. Pop. (1871) 31,751; (1897) 52,908. Near the town a fair is held after Easter, when more than £1,250,000 worth of commodities are disposed of, the chief being cotton, silk, and woollen fabrics, sugar, tea, leather, horses, &c. The government of Kursk, in the middle of south Russia, contains 17,931 sq. m., three-fourths fertile arable land (black earth). Pop. (1897) 2,394,893. The province is watered by numerous feeders of the Dnieper and the Don.

Kurtz, JOHANN HEINRICH, theologian, was born at Montjoie, near Aix-la-Chapelle, 15th December 1809, and was first destined for a commercial career, but early devoted himself to the study of theology at Halle and Bonn, and became in 1835 religious instructor at the gymnasium of Mitau, in 1850 ordinary professor of Church History (in 1859 of Exegesis) at Dorpat. He retired in 1870, and lived at Marburg till his death, 26th April 1890.

His writings are numerous, and some, owing to their usefulness, have been exceedingly popular, as the *Lehrbuch der heiligen Geschichte* (1843; 16th ed. 1884), *Christl. Religionslehre* (1844; 13th ed. 1883), *Biblische Geschichte mit Erläuterungen* (1847; 34th ed. 1882), and *Abriss der Kirchengeschichte* (1852; 11th ed. 1886). His works in the department of biblical criticism include *Das Mosaische Opfer* (1842), *Bibel und Astronomie* (1842), *Die Einheit der Genesis* (1846), *Zur Theologie der Paulina* (1865), and especially *Geschichte des Alten Bundes* (1848-55) and *Erklärung des Briefs an die Hebräer* (1869).

His most important books, however, are those devoted to church history, his *Handbuch der allgemeinen Kirchengeschichte* (1855-56), and the invaluable manual, *Lehrbuch der Kirchengeschichte für Studierende* (1849; 9th ed. 1885). Of the last there are three English translations.

Kuruman, a mission-station of the London Missionary Society in Bechuanaland, about 130 miles NW. from Kimberley. It was for many years the scene of the labours of Dr Moffat, and there Livingstone also laboured.

Kusi, a considerable tributary of the Ganges, rises in the Nepal Himalayas, to the north-west of Mount Everest, and flows generally south, in a rapid stream, with a great body of water, to the

main river. Its length is about 325 miles, and it is navigable, although with difficulty, by boats of ten tons, to the Nepal frontier. Its bed is constantly shifting to the westward, and its floods have turned wide tracts into sand and jungle.

Kuskoquim. See ALASKA.

Kustendji, or more properly since 1878 COXSTANZA, a seaport in the Dobrudja, Roumania, stands on the Black Sea, at the end of Trajan's wall and of the railway to Tchernavoda on the Danube. The harbour is exposed; but corn, wool, cattle, and hides are exported. Pop. 5000. Not far distant from the town was Tomi, the place of Ovid's banishment.

Küstenland. See GORZ.

Küstrin, a town of Prussia and a fortress of the first rank, is situated in the midst of extensive marshes at the confluence of the Warthe with the Oder, 51 miles E. of Berlin by rail. It was first fortified in 1535-43, and was held by the French from 1806 to 1814. Küstrin is also an important railway centre. Pop. (1885) 15,105.

Kutahia, or KUTAYA (the ancient *Coturum*), a town of Asiatic Turkey, in Anatolia, stands 70 miles SE. of Bursa, at a point where great commercial highways cross. Its inhabitants, variously estimated at 30,000 to 60,000, cultivate opium, tobacco, corn, and vegetables, and export wool, mohair, and opium.

Kutais. See TRANSCAUCASIA.

Kuttenberg, a mining-town of Bohemia, 185 miles by rail NNW. of Vienna. Its silver-mines were worked at least as early as the 13th century, and the first silver *grosschen* were struck here about 1300. The town contains a number of fine old buildings, and has miscellaneous manufactures. Close by is an imperial tobacco factory, with 2000 hands. Pop. (1890) 13,563.

Kutusoff, MICHAEL ILARIONOVICH, Prince of Smolensk, a Russian field-marshal, was born 16th September 1745, entered the Russian army at the age of sixteen, and in 1784 became major-general. He distinguished himself in the Turkish war, and was appointed in 1805 to the command of the first army corps against the French. In 1812, notwithstanding his advanced age, as commander-in-chief, he fought Napoleon obstinately at Borodino (q.v.), and obtained a great victory over Davout and Ney at Smolensk. Tolstoi calls him 'the genius of Russia and of the war.' He died 28th April 1813.

Kwilm. See GABOON.

Kyanising, a method of preserving ships from Dry Rot (q.v.), by injecting into the pores of the wood a solution of corrosive sublimate, was invented by John H. Kyan (born at Dublin, 1774; died in New York, 1850).

Kyanite. See CYANITE.

Kyd, THOMAS, dramatist, born in the autumn of 1558, seems to have been educated at Merchant Taylors' School, and was most likely brought up as a scrivener under his father. His bloody and bombastic tragedies of the *Titus Andronicus* order early brought him reputation. These were the two plays having for their hero Jeronimo, marshal of Spain. The first, dealing with the hero's earlier history, was not published till 1605; the second was licensed in 1592 as *The Spanish Tragedy*, but the earliest extant copy is dated 1594. The production of both may perhaps be dated between 1584 and 1589. Kyd published, in 1594, a tedious tragedy on Pompey's daughter Cornelia, translated

from the French, almost certainly produced *The Rare Triumphs of Love and Fortune* (1582) and *Solymann and Perseda* (1592), and has been credited with a greater or less share in other plays. He was a close friend of Marlowe, shared the odium of his irreligious opinions, and is supposed to have died in poverty in 1595. His name now survives only in Jonson's 'sporting Kyd and Marlowe's mighty line.' F. S. Boas edited him in 1901.

Kyle, the central district of Ayrshire (q.v.).

Kyōto, or MIAKO, for over a thousand years the capital of Japan (q.v.), is situated on a flat plain about 26 miles inland from Osaka. A high range of hills to the east separates this plain from Lake Biwa, and on these some of the finest temples connected with the city are built. The city is rectangular in form, the longer streets running north and south, parallel to the Kamo River, which flows along the base of the ridge. At the northern end are situated, in an enclosure, the plain wooden buildings where the emperors of Japan dwelt so long in seclusion. The Honganji temples of the Monto sect of Buddhists, fine structures of their kind and the centre of the Buddhist faith in Japan, rise at the southern end of the city. The streets, though narrow, are clean and attractive, and the whole city has an air of refinement. The singing-girls of Kyōto are noted for their graceful dances. The pottery, porcelain, crapes, velvets, and brocades of Kyōto are highly esteemed; its embroideries, enamels, and inlaid bronze-work, are marvels of skilful handicraft. Pop. (1895) 318,280.

Kyrie Eleison (Gr. *Kyrie eleison*, 'Lord, have mercy'), a form of prayer which occurs in all the ancient Greek liturgies, and is retained in the Roman Catholic mass. It follows immediately after the introit, the priest and the server saying alternately 'Kyrie eleison' thrice, 'Christe eleison' thrice, and again 'Kyrie eleison' thrice; the triplets are understood to be addressed to the three Persons of the Trinity. The Greek words have always been left untranslated in the Latin liturgy. In their translated form they are known to Anglican churchmen as the 'lesser litany,' and occur in the order for morning and evening prayer, and also in the Litany; processional litanies in the early church began with the phrase, and sometimes included as many as a hundred repetitions. The First Prayer-book of Edward VI. (1549) retained the 'lesser litany' after the introit; but in 1552 it was embodied in the short petition that follows each of the commandments, which were then inserted in the communion office.

Kyrie, JOHN (1637-1724), philanthropist, was styled the Man of Ross by Pope, having resided for the greater part of his life in the small town of Ross, Herefordshire. He spent his time and fortune in building churches and hospitals, on an income amounting to £600 a year. Pope celebrated his praises in his third *Moral Epistle*, and Warton said that he deserved to be celebrated beyond any of the heroes of Pindar. The Kyrie Society is a modern association named after him, and was started by Misses Miranda and Octavia Hill in 1875, and founded in 1877 by Prince Leopold and others. The society seeks to bring the influences of natural and artistic beauty home to the lives of the people by means of the decoration of workmen's clubs, of hospital wards, and of dwelling-houses; by the encouragement of window-gardening; providing concerts for the people; and by securing open spaces, both in town and country, to be laid out as public gardens. See an article in *Good Words*, 1881.

Kythul. See KATHRAL.

L



the twelfth letter in our alphabet, is descended from the Phœnician character called the 'ox-goad,' *lamed*, whence the Greek name *lambda* was derived. The letter *lamed* was probably a degraded form of the Hieroglyphic picture of a recumbent lioness, from which the hind-quarters have disappeared, leaving two straight lines, one of which represented the out-stretched fore-paws and the other the chest (see ALPHABET). The early Greek form λ passed over to Italy, where it became **L**. From λ , through the intermediate stage L , the Greeks got the form L (which was transmitted to the Runes), and this finally became Λ in the Greek capitals and λ in the minuscules. Our own minuscule form *l*, in which the horizontal bar is evanescent, was derived from the old Roman cursive. The Roman numeral for 50 was **L**, but this is not the letter of the same form, but was obtained from the western form of the Greek letter *chi*, the successive stages being \times , γ , \downarrow , L , and finally **L**.

The letter *l* is usually termed a 'liquid,' but is more correctly designated as a 'front palatal.' It has a great affinity with *r*, the positions of the vocal organs for forming *l* and *r* being nearly the same. In sounding *r* the breath escapes over the tip of the tongue, while for *l* the tip of the tongue touches the front palate or the base of the gums, the breath escaping over the two sides of the tongue, and the vibrations of the soft lateral edges producing slight oscillations in the force of the breath, whereas in the case of *r* a stronger trill is caused by the vibration of the tip of the tongue. In the Spanish *ll*, the Italian *gli*, and in the English word *glora*, the contact with the palate is made by the middle of the tongue instead of by the tip.

Owing to the affinity between *l* and *r* they are frequently interchanged. In some languages the same sign was used for both sounds, in others either *l* or *r* is wanting. The old Egyptians seem to have made no distinction between the two; in old Pali the signs were interchanged; the Japanese sign for *r* was borrowed from a character which represented *l* in Chinese; while the Polynesians substitute *l* for *r* in foreign words. In English a Latin *r* has become *l* in such words as *plum* (*prunus*), *turtle* (*turtur*), *purple* (*purpura*), *marble* (*marmor*), and *pilgrim* (*peregrinus*). We have the converse change in *chapter* from *capitulum*, and *colonel* from *herodula*, while *colonel* is now pronounced *coronel*.

The letters *d* and *n* have also an affinity with *l*. We have the change of *d* to *l* in *lacrima* for *lacryma*, *lingua* for *lingua*, *lupulus* from *lupulatus*, *sella* from *selula*, *alloguar* from *alloguar*. In the numerals *decem* and *twelve* the *l* is also believed to represent a primitive *d*. We find the change of *n* to *l* in *asellus* for *asinulus*, *collegium* for *conlegium*, and *Bologna* from *Bononia*.

In the spelling of several English words the letter *l* has fallen out, as in *such* and *each*, from the old English *sude* and *ate*. Though preserved

in the spelling, it is not heard in the words *alms*, *palms*, *calms*, *polls*, *hulfs*, *woulds*, and *shoulds*. A final *l* is often mute in the Scotch dialect, as in *a'* for *all*, *fa'* for *fall*, *fu'* for *full*. In modern French it sometimes fades to *u*, as in *aur* for *à les*, *du* for *de le*, *chevane* for *chevals*. In Italian it may become *i*, as in *piano* from *planus*. On the other hand, *l* is intrusive in *windlass* from O.E. *windlæss*, and in *myrtle* from *myrtus*, *principle* from *principium*, and *participle* from *participium*. From a false analogy with *would* and *should*, where the *l*, derived from *will* and *shall*, is radical, it has crept into the spelling, though not into the pronunciation, of *could*, which is the past tense of *can*. The M.E. form *coude* has no *l*, while the Dutch *konde* and the German *konnte* have preserved the *n* which belongs to the root.

Laager, in South African campaigning, is a camp made by a ring of ox-wagons set close together, the spaces beneath being filled up with the baggage of the company.

Laaland, or LOLLAND, a Danish island in the Baltic, at the southern entrance to the Great Belt, 36 miles long by 9 to 15 broad, with an area of 445 sq. m., and a pop. (1890) of 67,913. The surface is remarkably flat, and the soil exceedingly fruitful. Forests of beech and oak cover upwards of 50 sq. m. The capital is Maribo (pop. 2303); the largest town, Nakskov (pop. 5278), with a good harbour and considerable trade.

Lab'arum, the famous standard of the Roman emperor Constantine, designed to commemorate the miraculous vision of the cross in the sky, which is said to have appeared to him on his way to attack Maxentius, and to have been the moving cause of his conversion to Christianity. It was a long pike or lance, with a short transverse bar of wood attached near its extremity, so as to form something like a cross. On the point of the lance was a golden crown sparkling with gems, and in its centre the mysterious monogram of the cross and the initial letters of the name of Christ, the letters χ and ρ —Greek for χ and ρ —being combined (see Cross, Vol. III. p. 582). From the cross-beam depended a square purple banner, and surrounded by a rich border of gold embroidery. The cross was substituted for the eagle, formerly perched on the Roman standards, and there were sometimes other emblems of the Saviour. Between the crown and the cross were heads of the emperor and his family, and sometimes a figure of Christ woven in gold. The origin of the word is still uncertain, 'in spite,' says Gibbon, 'of the efforts of the critics, who have ineffectually tortured the Latin, Greek, Spanish, Celtic, Teutonic, Illyric, Armenian, &c. [and, he might have added, Basque] in search of an etymology.'

Label. See HERALDRY, and CADENCY.

Labiatae (*Lamiacea* of Lindley), a natural order of exogenous plants, containing almost 2500 known species, mostly natives of temperate climates. They are herbaceous, or more rarely half-shrubby, and have 4-cornered stems and opposite branches; also opposite leaves, without stipules, abounding

in receptacles of volatile oil. The flowers are often in cymes or heads, or in whorls, or sometimes solitary. A general characteristic of this order is an aromatic fragrance, which in many species is very agreeable, and makes them favourites in our gardens; but some are weeds with an unpleasant odour. Many are natives of Britain. Some are used in medicine, and others in cookery for flavouring. Mint, Marjoram, Rosemary, Lavender, Sage, Basil, Savory, Thyme, Horehound, Balm, Patchouli, Germander, and Dead Nettle are examples of this order.

Labiche. EUGENE MARIN, a French dramatist, was born at Paris, 5th May 1815, studied at the Collège Bourbon, and next travelled in Italy. His first dramatic piece was the popular farce *M. de Coillien* (1838), which was followed during the next forty years by a long series of over a hundred comedies, farces, and vaudevilles. These were all marked by rare mastery of stage technique despite the usual droll improbability of the plots, intimate knowledge of human nature, crisp and sparkling dialogue, and a lambent humour that is often caustic but never unkindly. He collaborated at one time or another with Gondinet, Delacour, Legouvé, Augier, and other dramatists. His *Fressette* (1846) was the original of Morton's 'Box and Cox.' Among the most important of his pieces are *Le Chapeau de Paille d'Italie* (1851); *L'Affaire de la Rue de Louvain* (1857); *Le Voyage de M. Perrichon* (1860); *Les Petites Déeses* (1863); *Célimaire le Bien-Aimé* (1863); *La Cagoulle* (1864); *Le plus Heureux des Trois* (1870); *Est-on le duc* (1873); *Les Trente Millions de Gladiateur* (1875); *Le Prie Martin* (1876); *La Cigale* (1877). A successful collection of his pieces appeared under the title *Théâtre de Labiche* (10 vols. 1879), with an introduction by Augier. Labiche was elected to the Academy in November 1880, and died 23d January 1888.

Lablache. LUIGI, operatic singer, was born in Naples on 6th December 1794; his father was a Frenchman, who had fled from Paris during the horrors of the Revolution, his mother an Irishwoman. His first engagement as a singer was at the San Carlino Theatre at Naples, in 1812. He afterwards sang with much success at Palermo (until 1820), at Milan, Rome, Turin, and Vienna; in the last-named city a medal was struck in his honour. From 1830 to 1852 he sang nearly every winter at Paris, and annually made visits to London, St Petersburg, and various cities in Germany. In London he was perhaps a greater favourite than even the wonderful Grisi. Lablache died at Naples on 23d January 1858. His voice, a deep bass, has hardly ever been equalled either in volume or quality; and his acting, particularly in the characters of Figaro, Don Bartolo, Don Pasquale, Leporello, &c., was almost as remarkable as his singing. He gave instruction in singing to Queen Victoria.

Laboulaye. EDOUARD RENE DE, a distinguished French jurist, was born in Paris 18th January 1811, became an advocate, and in 1849 was appointed professor of Comparative Jurisprudence in the Collège de France. His most important works are on French law, and a *Histoire Politique des États-Unis, 1620-1789* (3 vols. 1855-65; 6th ed. 1876). He also edited the *Recueil Historique* (1855-69), and its successors, the *Recueil de Législation* (1870-76) and *Nouvelle Revue Historique* (from 1877). Laboulaye attained some distinction as an essayist and story writer; some of his tales, including the humorous *Paris in Amérique*, have been translated into English. He took up a consistently moderate position in politics, and in consequence gained the enmity of extremists

on both sides. He was elected to the National Assembly in 1871, and in 1876 became a life senator. He died 25th May 1883.

Labour, in Political Economy, may be defined as effort for the satisfying of human needs. It is one of the three leading factors in production, the other two being land (or natural objects) and capital; and it is more fundamental than capital, which originally is the result of labour. In the vast circle of industry labour has a great variety of functions, which may be thus classified: (1) Producing of raw materials, as in mining and agriculture; (2) manufacturing in the widest sense of the word, or transformation of raw materials into objects serviceable to man; (3) distribution, or transference of useful objects from one place to another, as determined by human needs; (4) personal services rendered by physicians, teachers, &c.

A distinction insisted on by many economists is that into productive and unproductive labour. The former consists of those kinds of exertion which produce utilities embodied in natural objects. Unproductive labour, like that of the musician, while both useful and honourable, does not add to the material wealth of the community. Though it has the appearance of undervaluing some of the highest services that can be rendered to the community, the distinction has a general validity. Labour directly employed in rendering natural objects serviceable to man may in the language of political economy be distinctively called productive. But in order to obviate a too narrow and abstract view of the subject it is hardly necessary to point out that the labour of the physician or teacher may be indirectly most productive, inasmuch as it increases the efficiency of the workman by promoting his health and intelligence. And apart from the special services rendered by great teachers and artists, and which cannot be measured in material wealth, they raise the general level of production, and even of material civilisation, by inspiring men with finer tastes and higher needs. For the wants to which productive labour ministers vary at different stages of social development, and grow more refined as the human race advances.

The social and legal forms in which labour has appeared have also varied with the progress of civilisation. In the early stages the labour of the chase, fishing, &c. was performed by the men, while the drudgery devolved on the women and slaves. But at that stage few slaves existed. It was not till the agricultural stage was reached that conquering tribes spared the conquered in order to utilise their services as workers. Ancient civilisation was based almost entirely on compulsory labour. The pyramids and other great works of Egypt and Babylonia were possible only because governments could command forced labour on a colossal scale. The more highly developed societies of Greece and Rome rested on the same basis.

It is a disputed question how far free labour existed in the early Teutonic settlements of England and other countries. The question is evidently one of degree, for the Germans possessed slaves long before the great emigrations began, and even in England they did not entirely exterminate the natives. The medieval organisation of society, where definitely constituted, rested on serfdom, i.e. the mass of the workers were attached to the soil, and rendered fixed services in labour, in kind, and latterly in money. While the condition of serfdom greatly varied, there can be no doubt that its tendency was to depress the free and raise the servile cultivators to something like a common level. The free workers of the towns organised themselves in Guilds (q.v.). In the course of the 14th century serfdom began to pass away in England. Its disappearance was followed by enact-

ments for the regulation of labour in the interest of the ruling classes. The first, and one of the greatest, examples of this was the *Statute of Labourers* occasioned by the scarcity of labour consequent on the Black Death. The main object of this statute, which was passed in 1349 and was repealed only in the early years of Elizabeth, was to fix the amount of wages; and it was superseded by a statute of Elizabeth which, besides ordaining an apprenticeship of seven years, empowered the justices in quarter sessions to fix the rate of wages both in husbandry and handicrafts. This act of Elizabeth was not repealed till 1814. The poor law enacted at the close of her reign in 1601 may be described as a method of supplementing the low wages fixed by the justices (see *POOR LAW*).

Towards the close of the 18th century the effect of the industrial revolution was to organise labour in large factories and similar undertakings; and in the early decades of the 19th the growing ideas of freedom had begun to make other great changes in the condition of the workers. The right of combination received in 1824 was utilised in the formation of trades-unions and co-operative societies, and the admission of the working men to the franchise has given them a share in the political life of the country. Changes similar to those in England have taken place, only much later, in the countries of the European continent. The emancipation of agricultural labour from serfdom, which was effected in France at the Revolution of 1789, was not completed in central Europe till 1848, and in Russia not till 1861. Laws for the regulation of labour are now intended not to fix wages as formerly, but to protect the weaker class of workers. Such are the Factory Acts in England, which also have been followed by a corresponding development abroad. Efforts for the international organisation of labour proceeding from socialism have been followed by the international conference for the regulation of labour, which met at Berlin in 1890.

Another great result of social evolution in the most advanced countries of the world has been the more or less conscious and definite constituting of the labouring class as a separate class, with interests at variance with those of the possessors of land and capital. The solution of the questions connected therewith is now universally regarded as the most pressing duty of statesmen and economists (see *SOCIALISM*). In this connection it is maintained on the basis of the old political economy that labour, thus narrowly defined as the attribute of a special class, is the source and measure of value. For treatment of this fallacy, see *VALUE*. See also *DIVISION OF LABOUR*.

See Professor Thorold Rogers' *Six Centuries of Work and Wages*; also popular edition, *Work and Wages*; and the chapters on labour in the various systematic works on political economy.

Labour Day is a legal holiday in some parts of the United States, as in New York (the first Monday in September). The banks and government offices are closed, labour is suspended, and the labour organisations parade the streets and hold meetings. In Europe, as a result of the Labour Conference at Berlin in 1890, in many parts of the Continent the 1st of May was to some extent observed as a labour holiday.

Labourdonnais, BERTRAND FRANÇOIS MAHÉ DE, a famous French naval officer, was born February 11, 1699, at St Malo, and already in 1723 was captain in the naval service of the French Indies. Next year he distinguished himself so greatly at the capture of Mahé on the Calabar coast that he was permitted to add its name to his own. In 1734 he was appointed governor of the islands Ile de France and Bourbon, and his wise measures ere long made

them flourishing colonies. In 1740 he was given command of a squadron in East Indian waters, and during the next five years he inflicted great loss upon England. In September 1746 he compelled Madras to capitulate, but failed to push his success in consideration of a contribution of nine million livres. Accused by Dupleix of betraying the interests of the company, he returned to Paris in 1748, where he languished three years in the Bastille, but was set free and declared guiltless in 1752. He died September 9, 1753. Like most Frenchmen he wrote *Memoires* (1750), but his name best survives from its mention in *Paul et Virginie*. A monument was erected in 1859 at Port Louis on the Ile de France.—His grandson, Bertrand François Mahé de Labourdonnais (1795–1840), was a famous chess-player, and wrote a *Life of his grandfather* (1827).

Labourers. The only peculiar laws affecting labourers are where they come within the description of 'workmen' given in the Employers and Workmen Act, 1875. The act defines 'workman' as 'any person who, being a labourer, servant in husbandry, journeyman, artificer, handicraftsman, miner, or otherwise engaged in manual labour, whether under the age of twenty-one years or above that age, has entered into or works under a contract with an employer.' The act provides such labourers a speedy, easy, and cheap mode of recovering their wages when the amount is small, and affords masters an easy method of correcting misdemeanours and ill-behaviour on the part of the workmen. Labourers' wages are prohibited from being paid in kind or with goods by the Truck Act (q.v.). Other measures affecting labourers are the Factory Acts (q.v.), the extension of the franchise (see *PARLIAMENT*), the establishment of national Education (q.v.); the Workmen's Compensation Act, 1897 (see *LIABILITY OF EMPLOYERS*); see also the articles *ALLOTMENTS*, *GANGS*, *TRADES-UNIONS*, *MASTER AND SERVANT*. Numbers of Irish labourers still come over to England and Scotland at harvest time, returning again when harvest is ended. Italians to the number of 87,000 annually leave their homes for unskilled labour (as on railway laying) in Austria, Germany, and France. A prominent feature in the social economy of several Russian provinces (Samara, Saratoff, Yaroslav, Vyatka) is the large annual migration of their male population to work in more populous centres of Russia as smiths, masons, plasterers, carpenters, boatmen, gardeners, &c. For description of the condition of English agricultural labourers, see books by Jelferies (q.v.), Heath's *English Peasantry* (1874) and *Peasant Life in the West of England* (1880), and Jessopp's *Arday* (1887).

Labrador is the north eastern peninsula of the North American continent, lying between Hudson Bay and the Gulf of St Lawrence. The coasts were probably visited by the Norsemen about the year 1000; they were again sighted by Cabot in 1498. In 1500 a Portuguese navigator, Cortereal, seems to have visited it and to have given it its name, which means 'labourers' land.' Labrador extends from 49° to 63° N. lat., and from 55° to about 79° W. long. The greatest length from the Strait of Belle Isle to its northern cape, Wolstenholme, is 1100 miles; its area, 420,000 sq. m., or nearly five times the area of Great Britain. The Atlantic coast is stern and precipitous (1000 to 4000 feet high), entirely destitute of vegetation, deeply indented with narrow fjords, and fringed with chains of rocky islands. The inner parts of Labrador have been but very imperfectly explored; the greater part consists of a plateau, some 2000 feet above sea-level, and mostly covered with fine forest trees, firs, birches, &c. Numerous lakes,

including Mistassini (q.v.), also exist inland, and, connecting with the rivers, afford in summer continuous waterways for great distances. The only inhabitants of this interior plateau are Cree Indians, nomads. There are numerous rivers, 200 to 300 miles long and 2 and 3 miles wide at their mouths, flowing towards the Atlantic and Hudson Bay. The Grand Falls are 316 feet in perpendicular height, but from 4 miles above this, to the sea, there is a magnificent, almost continuous fall of 2000 feet. These rivers abound in fish, especially salmon and white-fish. The principal fur-bearing animals are bears, wolves, foxes, martens, otters, beavers, lynxes, &c. Of the mineral resources little is known; but iron and Labradorite (q.v.) are certainly abundant. The climate on the coast is very rigorous, owing mainly to the ice-laden Arctic current which washes the shores. The short three-months' summer is marred by the swarms of mosquitoes and black flies. The mean annual temperature at the missionary stations varies from 22 to 28°. The winter is dry, bracing, and frosty. The part draining to the St. Lawrence belongs to Quebec, and forms indeed the larger part of Quebec province; that draining to Atlantic belongs (since 1809) to Newfoundland; the rest is, since 1895, the territory of Ungava. The great wealth of Labrador is its fish—cod, salmon, herrings, and trout. As many as 30,000 fishermen from Newfoundland, Canada, and the United States visit its fishing-grounds in the season. The annual catch is valued at more than £1,000,000. There are some 6000 permanent settlers, Eskimo and French Acadians, in the coast region, collected chiefly at the Moravian missionary stations—Nain (founded 1770), Okkak, Hebron, Hopedale, &c.

See A. S. Packard in *Bulletin of the American Geographical Society* (1887 and 1888), and his *Labrador Coast* (1892); Hand, *Explorations of the Labrador Peninsula* (1863); and R. F. Holme in *Proc. Roy. Geog. Soc.* (1888).

Labradorite is one of the group of the Feldspars (q.v.), and a very important rock-forming mineral. Thus, it is a principal ingredient in many diorites, basalts, gabbros, and andesites. It is met with also in certain volcanic tuffs (Etna). As a rule it is colourless or gray, and seldom transparent. Here and there it occurs in large masses associated with schistose rocks, as on the coast of Labrador. This massive kind (Labrador stone) often shows a beautiful play of rich colours, takes a fine polish, and is cut into snuff-boxes.

Labridæ. See WRASSE.

La Bruyère. JEAN DE, was born at Paris in 1645. He belonged to a middle-class family, and was educated by the Oratorians, the rivals of the Jesuits. After leaving the Oratory he was chosen to aid Bossuet in educating the dauphin, and in 1673 was appointed treasurer of France for the city of Caen, a post which he resigned through disgust at the rapacity of his fellow officials. He became tutor to the Duc de Bourbon, the grandson of the Great Condé, and spent much of his time at Paris and Chantilly with the Comtes, from whom he received a pension until the date of his death. His *Caractères* appeared in 1688, ran through eight editions in seven years, and gained for its author a host of implacable enemies as well as an immense reputation. The book consisted of two parts, the one being a translation of Theophrastus, the other a collection of maxims, reflections, and character-portraits of the men and women of the time. To these portraits has been mainly due the wide and lasting popularity of the *Caractères*. La Bruyère, his editor Walekenær has truly said, 'made mirrors on which by some magic property the reflected faces of a whole generation of men and women have become indelibly impressed.' Bitterly assailed

for his personal satires, La Bruyère found a powerful protectress in the Duchesse de Bourbon, a daughter of Louis XIV., who is said, with what truth cannot be determined, to have aided him in the composition of the later sketches which he embodied in his work. His enemies, headed by Fontenelle and Thomas Corneille, were twice able to secure his rejection when he tried for a chair in the Academy. In 1693, however, he was elected, his success being greatly due to the energetic efforts made on his behalf by his patroness, who is said to have resorted to a stratagem by which certain Academicians were prevented from voting against him. La Bruyère—who never married—died on May 11, 1696, his death being caused by a decoction of tobacco administered to him by the king's physician with the view of relieving him from an attack of apoplexy. Reports that he had been poisoned by his enemies were at one time current, but have since been thoroughly disproved. His *Dialogues sur le Quichisme* were issued in 1699. They were directed against Fenelon, and show none of the literary power so conspicuous in the *Caractères*.

Though he cannot rank with Montaigne or Pascal, La Bruyère is a moralist of high standing and a writer of the highest excellence. Sainte-Beuve affirmed that his book should be at the hand of every author, and that to read parts of it daily would be no less helpful to every critic than the study of the *Imitatio* to every one of a tender and devotional spirit. In his style the clearness, precision, and classic elegance of the Louis XIV. men are united with a pathos, a freshness of phrase, and a richness of colour suggestive of the prose of a later epoch. Like most workers in apothegm and epigram, he falls at times into triteness and exaggeration; but he has singularly few dull pages. His book is built on no regular plan, and to this its peculiar charm is in no small measure due. The writer perpetually varies his subject and his manner. You have here a pregnant maxim, a clear-cut epigram, a piquant anecdote, an old truth reset with novel felicity of phrase—here a page of acute literary criticism—here a bit of dialogue as crisp and bright as the talk in a sparkling comedy—here a character-sketch, racy with ironic malice, and humour, and wit—there a passage glowing with a sombre repressed indignation which proves how deeply the author resented his countrymen's wrongs. A great writer rather than a great thinker, his insight into character is shrewd rather than profound. It has been truly remarked by Suard that, while Montaigne has painted man as he is in all times and in all places, La Bruyère has only painted the courtier, lawyer, financier, and *bourgeois* of the days of Louis XIV.

The best edition of La Bruyère is that included in the series *Les Grands Écrivains de la France*, edited by G. Seryois (3 vols. 1864-82); a recent English translation of the *Caractères* is that by Helen Stott (1890). See the notice by Suard prefixed to the edition of 1838, and Life by Seryois in the 'Grands Écrivains' series (1882).

Labuan, an island 30 sq. m. in area, lying 6 miles from the north-west coast of Borneo. Besides possessing a good harbour (Victoria), it has an extensive bed of excellent coal, which has been worked, though not with commercial success. Labuan is an active market for the products of the neighbouring islands (Borneo and the Sulu Archipelago)—sago, edible birds' nests, camphor, gutta percha, india rubber, rattans, pearls, tortoise-shell, and beeswax. Sago flour is manufactured. Average value of exports, £83,800; of imports, £81,000. The island became British in 1846, and since 1891 is administered by the British North Borneo Company. Pop. 6000, mostly Malays and Chinese. See BROOKE (SIR JAMES).

Laburnum (*Cytisus Laburnum*), a small tree, a native of the Alps and other mountains of the south of Europe, much planted in shrubberies and pleasure-grounds in Britain, on account of its glossy foliage and its large pendulous racemes of yellow flowers, which are produced in great abundance in May and June. It is often mixed with filix, and when the latter preponderates the combination has a fine effect. In favourable circumstances laburnum sometimes attains a height of twenty or even forty feet. It is very hardy, and nowhere flourishes better than in the north of Scotland. It is of rapid growth, yet its wood is hard, fine grained, and very heavy, of a dark-brown or dark-green colour, and much valued for cabinet-work, inlaying, and turnery, and for making knife-handles, musical instruments, &c. The leaves, bark, and particularly the seeds, are nauseous and poisonous, containing *Cytisine*, an emetic, purgative, and narcotic principle. Accidents to children from eating laburnum seeds are not unfrequent; but to hares and rabbits laburnum is wholesome food. A fine variety of laburnum, called Scotch Laburnum, by some botanists regarded as a distinct species (*C. alpinus*), is distinguished by broader



Laburnum (*Cytisus alpinus*).

leaves and darker yellow flowers, which are produced later in the season than those of the common or *English* laburnum. The form known as Adam's Laburnum (*C. L. adami*), now occasionally seen in British gardens, originated in the Jardin des Plantes at Paris, about 1810, and is peculiar in producing the ordinary flowers of the common laburnum and those of another species (*C. purpureus*) in an irregular and indiscriminate way over its branches. The peculiarity is considered to be the result of grafting or budding the one species on the other.

Labyrinth, the name of some celebrated buildings of antiquity, consisting of a series of intricate chambers or passages. Of these the most celebrated were the Egyptian, the Cretan, and the Samian. The Egyptian was visited by Herodotus and Strabo, and was reckoned one of the wonders of the world, containing 3000 chambers. It was built on the shore of Lake Moeris, and its foundations were discovered by Lepsius (see FAYYUM). The Cretan labyrinth was supposed to have been built by Dædalus for King Minos, to contain the Minotaur. The only mode of finding the way out of it was by means of a hank or skein of linen thread, which gave the clue to the dwelling of the Minotaur. The Samian labyrinth was constructed in the age

of Polycrates (540 B.C.). Other inferior labyrinths existed at Nauplia, at Sipontum in Italy, at Val d'Ispeia in Sicily, and elsewhere; and the name of labyrinth was applied to the subterraneous chambers of the tomb of Porsena, supposed to be that now existing as the Poggio Gazella, near Chiusi. Labyrinths called mazes were at one time fashionable in gardening, being imitations, by hedges or borders, of the Cretan; the best known in modern times is the Maze at Hampton Court.

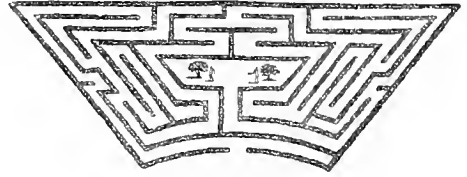

Maze at Hampton Court.

An ancient story told in Fabian's *Chronicle*, also in Higden and other early historians, and blindly followed by their successors, makes a maze at Woodstock the scene of Queen Eleanor's apocryphal vengeance upon Fair Rosamond.

Labyrinthodonts, or STEGOCEPHALL, a race of extinct Amphibians, the remains of which are found in the Permian, Carboniferous, and Triassic strata. Many of them were giants compared with our modern amphibians, from which they also differed markedly in possessing an armature of bony plates in various degrees of completeness. The order includes numerous genera, some of the salamander type, others limbless-like

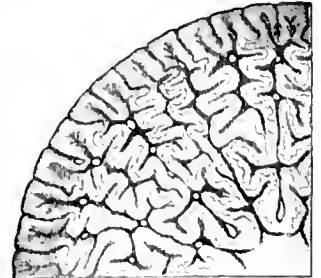

Transverse section of a Tooth of snakes, and leading on to the modern Cecilians.

The name Labyrinthodont refers to the mazy pattern exhibited on a transverse section of the teeth of some genera. Some of these ancient forms were probably responsible for footprints in the rocks which used to be placed to the credit of a more or less mythical animal, *Cheirotherium*. See *Textbook of Palæontology* by Nicholson and Lydekker (Edin. 1890).

Lac, best known in the form of shell-lac, is a coloured resinous substance of great importance in the arts. It is produced by a small insect from $\frac{1}{4}$ th to $\frac{1}{3}$ th of an inch in length—called *Coccus lacca* (*Carteria lacca* of Signoret), belonging to the sub-order Homoptera of the Hemiptera, or Bugs. Lac is found in India, Burma, Siam, China, and in some of the islands of the Eastern Archipelago. The lac-insect lives upon the young branches of many different species of trees, but the best lac is collected from two or three species of fig, *Zizyphus* and *Butea frondosa*.

As soon as the young are hatched they crawl about in search of sappy twigs. To these they fix themselves by their proboscides, and immediately begin to form their lac cells or cocoons. These have one anal aperture and two others for the admission of air, and in their cocoons the insects remain in a lethargic state for two and a half months. The females, which greatly outnumber

the males, never leave the spot to which they attach themselves, but the males escape by a ventral opening in the cocoon. After impregnation the female feeds voraciously on the juice of the twig to which it is fixed, increases in size, and continues to form lac. The lac surrounds all parts of the insect except the mouth and the three apertures already mentioned. When the young are perfectly formed they issue by the anal opening in the lac incrustation. Naturalists are divided in opinion as to whether the lac is secreted by the insect itself, or whether it is not merely the resinous juice of the trees altered in character by the insect while making its puncture, or just after it is made.

The appearance of the incrustation varies. It often takes the form of coalesced rounded prominences, at some places surrounding, at others scattered over, the branches; but in other instances it looks, superficially, more like a thick, irregular outer layer of bark roughened on the surface. The incrustation is cellular, each cell indicating the position of the insect which formed it. *Stick-lac* is the name given to it when the incrustation is still attached to the twigs, which are usually cut into pieces from three to six inches long. The next step is to remove the lac by a roller moving on a platform, the detached fragments being afterwards placed in tubs of water, and beaten by pestles or trodden by men. It is now in the state of *seed-lac*. The water left in the tubs is coloured red by the bodies of the insects, and, after this water is evaporated, the red substance is made into cakes, forming the lac-dye of commerce (see **DYEING**). After drying the seed-lac is melted in cylindrical cotton bags before charcoal fires, and, by twisting the bags, forced through the pores of the cloth. It drops into troughs, and is either allowed to spread out itself, or is spread by a strip of leaf upon a roller, into a thin sheet. After the impurities are broken out, the flakes are packed in bags, forming the *shell-lac* of commerce. Another form is *button-lac*, which is made by letting the melted lac drop into rounded pieces from 1-1½ inches in diameter.

In India a good deal has been done in the cultivation of lac by transporting the encrusted branches to suitable forests about a fortnight before the young insects begin to move about. The twigs with the insects in the larval state are tied on branches of trees which have been selected for the rearing of future broods. The inland trade for the year 1889 was valued at 101 lakhs of rupees.

Lac has many industrial applications. Shell-lac varnish is more extensively employed than any other spirit varnish. One variety of it is French Polish (q.v.) for furniture (see also **LACQUER**). Lac applied as an alcoholic solution is used to stiffen the calico frame of silk hats (see **HAT**). In fine sealing wax it is the most important ingredient, and either alone or mixed with other bodies it forms a good Cement (q.v.). Personal ornaments, such as chains and bracelets, are largely made of lac in India, and, when mixed with sulphur and some colouring matter, it is used there for coating wooden toys. Another mixture of lac with vermilion, closely resembling red sealing-wax in appearance, is applied by the Chinese to the surface decoration of boxes, trays, vases, and other small articles.

Lac, or **LAKH**, from a Sanskrit word meaning 'one hundred thousand,' is generally employed in India to indicate 100,000 rupees, the nominal value of which is £10,000 or \$48,600; but in consequence of the depreciation in the value of silver the real value is only £8333 or \$40,500.

Laccadives (Sansk. *Laksha Dvipa*, 'the Hundred Thousand Islands'), a group of fourteen coral islands in the Arabian Sea, between 10 and

14 N. lat., and about 200 miles W. of the Malabar coast. Area, 744 sq. m.; pop. (1891) 14,440. They are low and flat, and all but two are comparatively barren. The cocoa-nut is the chief plant, and *coar* (cocoa-nut fibre) the staple product. This and jaggery, cocoa-nuts, copra, tortoise-shell, and cowries are carried over to the mainland by the men, who are brave and skilful sailors. The number of large boats owned in the islands is 184, of small craft 719; the annual exports average about £17,000. The group was discovered by Vasco da Gama in 1499. The northern islands are attached to the Madras district of South Kanara; the rest belong to the rajah of Cannanore, but since 1877 have been administered by the collector of Malabar. The people are Mohammedans of Hindu descent, their language Malayalam, except in Minikoi, which properly belongs to the Maldivic group and retains its language.

Lace is an ornamental fabric of linen, cotton, silk, or gold and silver threads, made by looping, knotting, plaiting, or twisting the thread into definite patterns, of contrasted open and close structure. Three distinct varieties of lace are made, two by handwork, known respectively as *needle or point lace* and *pillow-lace*, and one by machinery. To hand-made lace the term real lace is sometimes applied, and, although it may be made in all or any of the varieties of thread above enumerated, in general it is composed of white linen thread of exceedingly great delicacy and tenacity. Machine-made lace on the other hand usually consists of cotton thread of high counts, but it cannot be used of such fineness as linen; while with machines it is quite impossible to rival the combined grace, delicacy, and strength of ornamental structure obtainable by the skill and patience of the hand worker. Nevertheless machine-made lace is a marvellous triumph of mechanical ingenuity, and more inventive genius has been devoted to its production than has been bestowed on any other branch of textile industry.

Lace on one side, as needle or point lace, is closely allied to embroidery; pillow-lace is derived from and merely an elaboration of plaited fringe-work; and machine-lace is a development of fancy weaving. Although we have these three distinct methods of lace-making, combinations of the whole may be found in one piece of modern lace, and frequently the products are so similar that it requires both experience and close observation to distinguish what is made by the needle from the plaited product of the pillow, or even the twisted lace of the machine. Technically, lace consists of two elements, the pattern, flower, or gimp which forms the closer-worked and more solid portion of the fabric, and the ground or filling which serves to hold the pattern together and in its proper place. In some varieties of lace, however, the ground is almost entirely wanting, and the pattern holds together by joining at the edges where two portions of the design meet and touch. In other cases the ground consists of ties or brides, thin loops or plaits passing from the edge of one portion of the pattern to another contiguous, and thus tying them together. More frequently the ground consists of a delicate filmy honeycomb called a *resseau*, of which the simplest form is the bobbin-net, now made by machinery. On the *resseau* the pattern is sometimes stitched down after being separately made, such lace being known as *appliqué* or applied; in other cases pattern and *resseau* are formed together by needle or bobbin or by both. Other technical terms are met with in the description of lace—as *cardonnet*, a stout thread or several threads together employed to outline the pattern; *pecol*, a minute loop worked on the edge of ties or flowers for their enrichment; and *nodes*, which are ornamental

fillings, variations of the *resseau*, which is always a plain honeycomb mesh.

Point-lace is a fabric which appears to have been arrived at through the efforts to produce light, graceful, and airy effects in embroidery. It is not

known to have been made earlier than the first half of the 16th century; and its original production, as well as its most varied triumphs, are associated with Venice. The stages by which it developed from embroidery-work can be traced from the illus-

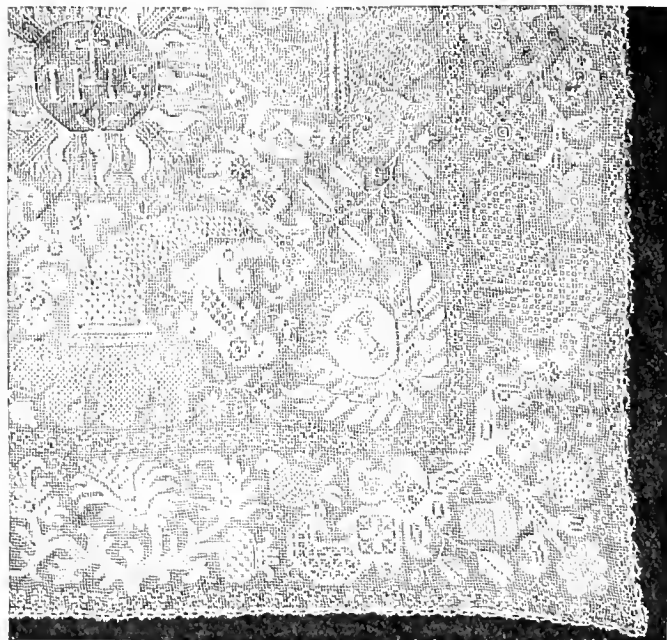

Fig. 1.—Part of Liturgical Veil or Cover, in *punto a maglia* or *laeis* work.

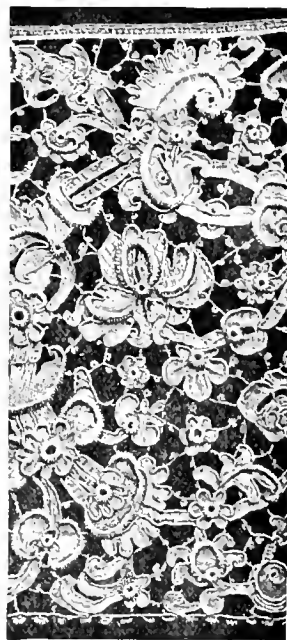

Fig. 3.—Rose-point, Venetian, 18th century.

trated pattern-books for embroiderers which were issued early in the 16th century. In these books we find two styles of work intermediate between embroidery and lace-making, one of which consists of patterns cut out of stuff, and having the cut edges sewn over with a button-hole stitch, such work being known to the Venetians as *punto tagliato*. The second method of producing a lace-like effect was by cutting the individual threads in any texture in accordance with a definite pattern, and drawing out the cut portions, the resulting design, partly open work and partly close, being known as *punto tirato*. The converse of this consisted in darning in patterns on a gauze or other

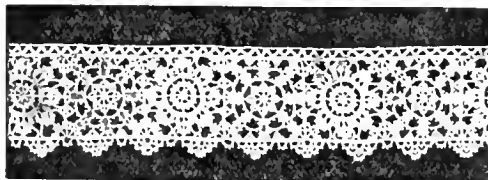

Fig. 2.—Reticella Needle-point Lace, Italian, 16th century.

open woven texture, a class of work termed by the Italians *punto a maglia* (see fig. 1), and by the French *laeis* or *bassis*—whence our 'lace,' which has taken the place of the earlier name *passement* or *passement*. The earliest true needle-lace of Venice, known as *punto in aria* or *reticella*, was in its design similar to the cut work of the pattern books, showing only rectilinear and geometrical forms, as in fig. 2. A gradual development can be traced from such simple forms into rich floral ornaments and scrolls, till early in the 18th century, in the

very delicate needle-point with meshed ground known as *point de l'aise à resseau*, we come to the richest and most elaborate products of the north Italian needlewomen. The most characteristic and valuable of the laces of Venice is that known in Britain as *rose-point* (French *gros-point*) (fig. 3), which consists of patterns worked in relief like sculptured work, forming strong and solid flowers and scrolls, held in position by ties or brides enriched with picots. With such lace the robes of great ecclesiastics and wealthy nobles were adorned, and it was also employed for the ornamentation of altar covers and other church textures. In the making



Fig. 4.

of point-lace the design is first drawn on a piece of parchment, which is then stitched down to a backing of stout linen. Over the lines of the design one or more threads of linen are stitched lightly down, and the slow work of filling up the pattern with button-hole stitches proceeds on the thread outline so obtained. The methods of working are numerous, and some of the stitches indeed have been lost, but commonly the pattern or cloth is obtained by laying down a series of threads parallel to each other, as in fig. 4, and over-stitching them as shown. For the brides or *resseau* a single thread may form the foundation, it also being closely stitched over, as seen in fig. 5. When pattern and fillings are finished, it remains only to cut the



Fig. 5.

stitches which hold the outlining threads to the parchment and the linen backing, thus liberating the lace. From Venice the art of making point-lace travelled out to other Italian towns, and westward to France and Flanders. Principally owing to the efforts of the minister Colbert, who in 1665 chartered a company with exclusive privileges for ten years and a subsidy of 36,000 livres, the art was firmly established in France, ateliers being established in several of the principal towns. Among these places was Alençon, where Venice lace of very fine quality was being made by a lady named Laperriere prior to the establishment of Colbert's company. Alençon lace and the closely-allied fabric made at the neighboring town of Argentan attained great perfection during the 18th century. The designs employed were distinctively French in character, and the réseau and modes which formed the filling showed a minute and filmy delicacy unapproached by the products of any other district (fig. 6).

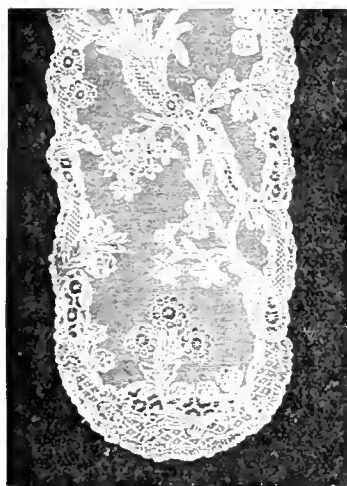

Fig. 6.—Portion of Alençon Lappet; French, late 17th or early 18th century.

From a picture by Quentin Matsys, painted in 1495, we have evidence that the making of pillow-lace was known in Flanders at that early date; but about the same time it was also being worked in Venice under the name of *Merlotti o piombini*. While point-lace making has always been the distinguishing character of Italy and the south, the making of pillow-lace became and remains distinctively associated with the Flemish towns and with England. For the production of pillow-lace the pattern is first drawn in mill size on a piece of parchment, which is then fastened to a pillow or cushion made to rest in the lap of the worker, and into which pins may be easily and firmly stuck at any required point. The pattern is then pricked over with pin-holes at every point where pins require to be inserted in the subsequent work of twisting and plaiting. The lace maker is also provided with a series of small bobbins, round the upper part of which the thread to be used is wound, and even for the production of a half-inch band of lace of simple pattern a vast number of pins and as many as fifty bobbins may be required, while for elaborate patterns twelve hundred bobbins may be brought into requisition on a single pillow. The whole work in pillow-lace is the result of twisting and plaiting, and the pattern is often outlined and sometimes filled up with thread of a stouter character than that used on the mesh and fillings. The

simplest ground in the pillow-lace consists of the twisted net or hobbin-net, originally made on the pillow, but now entirely made by machinery (see fig. 7). More commonly the net is partly twisted and partly plaited; and the variations in the mesh so formed are characteristic of the different classes of pillow-lace. Thus, the mesh of Mechlin lace consists of four twisted and two

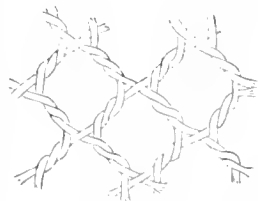

Fig. 7.

plaited sides, as seen in fig. 8. The mesh of Brussels pillow-lace is similar to that of Mechlin, but the plaited sides are longer (fig. 9), while the Valenciennes mesh is plaited throughout. These differences in the form of the ground of pillow-laces give a different

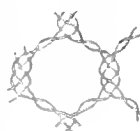

Fig. 8.

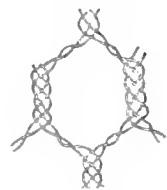

Fig. 9.

appearance to the reticulations. The flower or pattern of the lace is worked so as to give it the appearance of plain woven cloth (see fig. 10). The Valenciennes mesh renders that variety more solid and durable than any of the others. Much of the modern Brussels lace has now a machine-made ground instead of the ancient pillow meshes, on which the separately-made flowers are applied or sewed by the imperceptible fine joining stitch. The making of pillow-lace in Honiton and other localities in the south-west of England was begun towards the end of the 16th century by refugees from the Low Countries. In 1662 parliament, desirous of encouraging native lace-making,



Fig. 10.

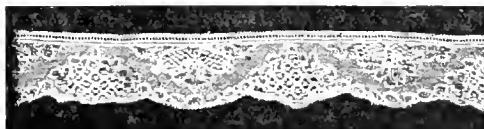

Fig. 11.
Border of Mechlin Pillow-lace, early 18th century.

prohibited the importation of all laces of foreign manufacture. Lace-workers were thereupon encouraged to settle in England; but as the fine

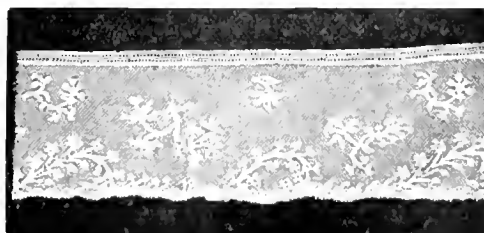

Fig. 12. Valenciennes Pillow-lace, with réseau ground, late 18th century.

thread necessary for their work was not forthcoming they were forced to return to their native

land. A vigorous smuggling trade between Brussels and England ensued, and the lace so introduced was freely sold as English point, whence Brussels lace came to be generally known as *Point d'Angleterre*. Honiton lace from the 17th century downwards has continued to be made in the same style as the Flemish laces, but at no time has it attained the celebrity acquired by the products of the great centres of the pillow-lace making in Belgium

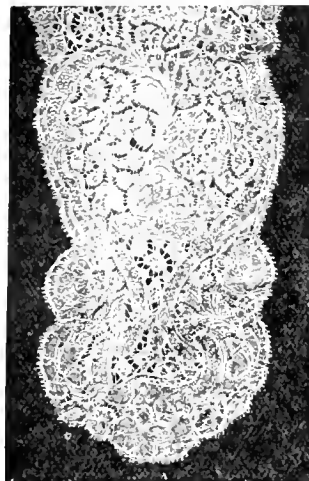

Fig. 13.—Portion of Honiton Lappet, 18th century.

and the north of France. Fig. 13 is a fine example of Honiton lace-work.

The successful imitation of hand-made lace by machine-work, and the consequent enormous cheapening of material which bears a superficial resemblance to the costly product, has proved almost fatal to the arts of needle and pillow-lace making. Of late years an attempt has been made to re-establish the manufacture of fine point-laces on the island of Burano, near

Venice. Similarly, efforts have been made to revive the industry in Honiton, and at the present time much is being done to encourage the development of the art in various directions in conventual and other establishments in Ireland. The stimulus in all these cases is, however, obviously artificial, and it cannot be said that there is at present any really healthy indication of revived demand for these supreme products of patience and ingenuity.

Machine-lace.—The ground and simplest element of pillow-lace being a network of meshes, the earliest efforts of inventors were directed towards the producing of machinery for fabricating similar netting. The hosiery frame, which had been invented by William Lee towards the end of the 16th century, was the first apparatus with which it was attempted to make a lace net, and about 1764 a modification of the frame was devised by which an open loop-net was produced. By the various devices familiar to hand-knitters fancy patterns could be produced on this machine. The loop fabric, however, had the great disadvantage of unravelling freely at any point where it was broken, as it was constructed of a continuous single thread. At a subsequent period what was known as the warp-lace machine was introduced, in the use of which a separate thread is supplied to each hooked needle employed in the production of the web. On these warp-threads loops are formed by mechanical means, and as they can be moved by the machine either to the right or to the left, neighbouring warps and loops are joined together, and in this way a solid web, which can be cut without unravelling, is obtained. Towards the end of the 18th century a great variety of figured lace began to be made on the warp-machine, and in a greatly improved form it still continues in use.

A new era, however, in machine lace making was inaugurated when, in 1809, John Heathcoat patented his second bobbin-net machine, by which

it was made possible to twist or wrap round each other an indefinite number of threads, and to cause any one thread to traverse, mesh by mesh, every other thread in the width of the fabric being netted. The bobbin-net machine of Heathcoat became the foundation of an enormous industry, and the inventor reaped both honour and ample pecuniary reward for his remarkable ingenuity. His frame has been modified by many inventors, but the most important improvements were effected by John Levers in 1813. The lace-making machine now principally used is known as the Levers machine, but of its complicated structure it would be quite impossible to convey any clear conception within moderate limits. The structure of the simplest fabric produced by it is shown as it appears on the frame in fig. 14; and when dressed and finished this fabric has the appearance indicated in fig. 7, which is common bobbin net. It will be seen that the texture is formed of a series of vertical parallel threads which may be taken to represent

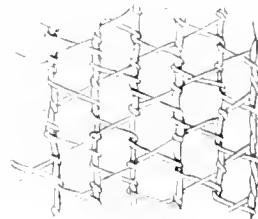

Fig. 14.

the warp of a common web, these being diagonally crossed and intertwined with others which may be looked on as weft-threads. The frame or loom holds the warp-threads vertically, a space being left between each sufficiently wide to admit of a shilling being passed edge-ways between them. Behind these threads, and corresponding to the interspaces, is a row of ingeniously constructed flat bobbins or reels resting in an arrangement called a *comb-bar* or *bolt bar*. These are so placed that with the first movement of the machine each bobbin, which carries its thread with it, passes through two of the parallel and perpendicular threads of the warp, and is lodged in another and similar bolt-bar in front of the warp. But this front bolt-bar, besides an advancing and reeling motion, has another movement, called *shooing*—from right to left. When it receives a bobbin by its forward motion it draws back, bringing the bobbin and thread through two of the upright threads; then it *shoos* or moves to one side, and goes forward again, taking the thread through the next two warp-threads, and lodging the bobbin on the back bolt-bar again, one distance beyond its last space; this it recovers by the next movement, and it again passes through the first space, to be again received by the front bolt bar. By these movements the bobbin thread is twisted quite round one upright thread of the warp; another movement then shifts the bobbin, so that it will pass through the next pair of upright threads, and so carry on its work, the warp-threads moving at the same time, unwinding from the lower beam, and being rolled on the upper one. There being twice as many bobbins as there are threads in the warp, each bolt bar having a set which it exchanges with the other, and all being regulated with great nicety, a width of lace is made in far less time than has been required to write this short description. The additions to and variations upon these operations (which only apply to bobbin-net), for the production of patterns, are numerous and complicated—each pattern requiring new combinations; but they all depend upon the variations which can be given to the movements of the flat disc-like bobbins.

Gold Lace and Silver Lace.—The so-called gold thread which is used in textiles consists of silver-gilt wire, or for commoner purposes copper-gilt wire, either round or flattened into a fine ribbon.

These wires may be so used for weaving and embroidery purposes, but generally what is called gold thread consists of a yellow thread of cotton or linen round which the flattened gold wire is spirally wound so as to completely encase it. Silver wire is similarly prepared and used, being wound on a white instead of a yellow basis. Gold and silver threads may be used in ordinary lace-making, but what is generally termed gold and silver lace consists of braids, ribbons, and bands of these materials employed for embroidery and braiding, and for the ornamentation of uniforms and official robes, badges, &c. The use of gold and silver wire in textiles is of great antiquity, and sumptuous garments enriched with precious metals must have been used in Egypt for royal and priestly personages in the time of Moses; for we find (Exod. xxxix. 2, 3) directions for making gold-embroidered robes for Aaron in the wilderness. The making of gold and silver lace is associated with the ribbon industry, and it is usually prosecuted in districts where that trade is located. Lefebvre, *Embroidery and Lace, their Manufacture and History* (Eng. trans. 1888).

See Felkin, *Machine- wrought History and Lace Manufacture* (1867); Palliser, *History of Lace* (1875); *The Art of Lace Making* (1881); Segum, *La Dentelle* (1874); Despières, *Histoire du Point d'Aleçon* (1888); Doumet, *La Dentelle* (1889); Lefebvre, *Embroidery and Lace* (Eng. trans. 1888); and the catalogue of Mr Chick's *Collection of Antique Lace*, to which this article is indebted for illustrations.

Lace-bark Tree (*Loxetta tinctoria*), a tree of the natural order Thymelæaceæ, a native of the West Indies. It is a lofty tree, the inner bark of which has all the appearance of coarse lace. A governor of Jamaica is said to have presented to Charles II. a cravat, hilt, and ruffles made of it.

Lacedæmon. See SPARTA.

Lace-leaf. See LATTICE LEAF.

Lacépède. BERNARD DE LA VILLE, COUNT DE, French naturalist, was born on 26th December 1756, at Agen, and was appointed curator of Natural History in the Royal Gardens at Paris in 1785. At the Revolution he became professor of Natural History in the Jardin des Plantes and at the university. He was made a senator in 1799, a minister of state in 1809, and in 1814 a peer of France. He died of smallpox at Epinay, near St Denis, 6th October 1825. Besides continuing Buffon's *Natural History* at Buffon's own request—in *Histoire des Reptiles* (2 vols. 1788-89)—Lacépède wrote *Histoire Naturelle des Poissons* (6 vols. 1798-1803), which, in spite of numerous errors, was long held in high esteem, and works on the Cetacea, the *Natural History of Man*, *Les Aps de la Nature*, and a *General History of Europe* (18 vols. 1826). Lacépède was likewise a highly accomplished musician, and published *La Poétique de la Musique* (2 vols. 1785). An edition of his works appeared at Paris in 3 vols. in 1876.

Lacertidæ. See LIZARD.

Lachaise. FRANÇOIS D'AIX DE, a Jesuit, born of a noble family, 25th August 1624, in the castle of Aix, now in the department of Loire, made his studies at Rohan, and was already a provincial of his order when Louis XIV. selected him for his confessor on the death of Father Ferrier in 1675. His position was one of great difficulty, owing to the different parties of the court, and the strife between Jansenists and Jesuits. In the most important questions of his time Father Lachaise avoided extreme courses. A zealous Jesuit, and of moderate abilities, he yet sustained among his contemporaries the reputation of a man of mild, simple, honourable character. Madame Maintenon could never forgive him the little zeal with

which he opposed the reasons urged against the publication of her marriage with the king; but during the thirty-three years that he filled his office of confessor he never lost the favour of the king. He died 20th January 1709.—Louis XIV. built him a country-house to the east of Paris, the large garden of which was in 1804 converted into a burial-place, and is known as the *Pantheon-Lachaise*, the resting-place of many famous men. See PARIS.

Laches. In English law, is a word used (from Fr. *lâcher*, 'to loosen') to denote negligence or undue delay, such as to disentitle a party to a particular remedy, or to relief. According to the common law this principle has no application as regards the crown; but various statutes, chiefly the so-called *Nullum Tempus Act* (9 Geo. III. chap. 16), have restricted the rights in this respect.

Lachine. a town of Quebec, Canada, 8 miles SW. of Montreal by rail, a favourite summer residence. There is a canal hence to Montreal to avoid the Lachine Rapids of the St. Lawrence.

Lachlan. a river of Australia, a tributary of the Murrumbidgee, which itself, a little farther down, enters the Murray (q.v.).

Lachmann. KARL KONRAD FRIEDRICH WILHELM, a celebrated German critic and philologist, was born, 4th March 1793, at Brunswick, studied at Leipzig and Göttingen, became an extra ordinary professor at Königsberg in 1818, at Berlin in 1825, and an ordinary professor there in 1827. He was admitted a member of the Academy of Sciences in 1830, and died 13th March 1851. Lachmann's scholarship was extraordinary alike in profundity and range. He was equally devoted to classical and German philology, and illustrated both by a singularly subtle and sagacious criticism evolved in strictly scientific method. Among his most important productions are his editions of the *Nibelungenlied*, the works of Walter von der Vogelweide, Propertius, Catullus, Tibullus, Babrius, Avianus, Gains, and the *Agrimensores Romani*. In his *Betrachtung über die Hiios* (supplemented by Haupt, 1847) he maintained that the *Iliad* consisted of sixteen independent *lays* enlarged and interpolated in various ways. The smaller edition of his New Testament appeared in 1831 (3d ed. 1846); the larger, in 2 vols., in 1842-50. The design of the last of these works was to restore the Greek text as it existed in the Eastern Church in the 3d and 4th centuries; and Lachmann attached the greatest value to the readings found in the old Latin and Greek western mss., where he found differences in his oldest eastern texts. His latest undertaking was his edition of Lucretius (1850), which Monro styles 'a work which will be a landmark for scholars as long as the Latin language continues to be studied.' See the Life by Hertz (Berlin, 1851), and also J. Grimm in vol. i. of his *Kleinere Schriften*.

Lachrymal Organs. See EYE.

Lackawanna River. Pennsylvania, is a tributary of the Susquehanna, and its valley nearly coincides with the Wyoming and Lackawanna coal basin (55 miles long), which produces half the anthracite mined in the United States.

La Condamine. CHARLES MARIE DE, French geographer (1701-74), served in the army, travelled extensively, and was sent with others to Peru (1735-43) to measure a degree of the meridian there. On his return he explored the Amazon, and brought the first definite information as to india-rubber. He also brought Curate (q.v.) to Europe, and wrote in favour of inoculation.

Laconic. The Spartans, or Lacedæmonians (whose country was called Laconia), systematically endeavoured to confine themselves to a sen-

tentious brevity in speaking and writing; hence the term *laconic* has been applied to this style.

Lacordaire, JEAN BAPTISTE HENRI, was born at Reçy-sur-Orce, in the department Côte-d'Or, March 12, 1802. He was educated at Dijon, and there began to study law. In 1822 he went to Paris, and practised successfully for two years as a barrister. His religious views were quite unsettled at this time. 'He was a deist, like all the youth of his day, and a liberal, like almost every Frenchman, but without any extreme views.' The spiritual change in him came suddenly, and then his true life began. He gave up his profession, entered the college of St Sulpice in 1824, and was ordained priest in 1827. In 1828 he became chaplain of the convent of the Visitation and in 1829 chaplain of the Collège Henri IV. Marked out by his Liberalism, he was asked to help the Abbe Lamennais and Montalembert in the establishment of the *Avenir*, the well-known High Church and Radical newspaper. In 1831 Lacordaire and Lamennais were summoned by Government, but acquitted, for writing in the *Avenir* against the appointment of three bishops by Louis-Philippe. Soon after this Lacordaire and Montalembert opened a free school in Paris, claiming as a right the liberty of teaching promised in the charter of 1830. The school was closed by the police, and Lacordaire and Montalembert were tried and fined one hundred francs. Thirteen months after its first appearance the publication of the *Avenir* was suspended, and, being condemned by the pope, was then finally given up. In 1834 Lacordaire gave a series of Conferences to the students of the College Stanislas which attracted great attention, and led the way to his famous Conferences in Notre Dame, delivered in 1835 and 1836. His audiences were immense, his success as a preacher was at its height, when he suddenly withdrew and went to Rome, feeling the need for himself of silence and solitude. In 1839 he entered the novitiate of the Dominican order, and in 1840 reappeared in the pulpit of Notre Dame, clothed in the habit of a Dominican monk. The next three years of his life were spent partly in France and partly in Italy. In 1843 he resumed his Conferences in Notre Dame, and continued them till 1851. In the revolution of 1848 Lacordaire accepted the republic, and was elected to the Constituent Assembly, but resigned his seat ten days after his election, as he found he was unsuited for the storms of parliamentary life. His last Conferences, delivered at Toulouse in 1854, are the most eloquent of all. After finishing these Conferences he undertook the direction of the military school of Sorrze, and at this post he remained till his death, which took place in 1861, a year after his election as Academician. Lacordaire was one of the greatest of modern preachers and orators. He laid hold of the thoughts of the day, he understood the difficulties he had to deal with, and he won men to the truth by his eloquent reasoning and by his love for their souls. A collected edition of his works appeared in Paris (9 vols. 1872). See Lives by Montalembert (1862; Eng. trans. 1863), Dora Greenwell (1867), and Lear (1882).

Lacquer. Ornamental or useful articles of brass, such as gas fittings and some kinds of furniture, are usually lacquered to preserve the surface from discoloration or corrosion. Iron, tinplate, and other metals and alloys are also sometimes lacquered. The lacquer used is composed essentially of shell lac or seed-lac, or both, dissolved in spirits of wine. But its composition varies considerably. One kind consists of 2 parts of shell lac dissolved in 20 parts by weight of alcohol, less than 1 part of turpentine being mixed with

it. It is customary, however, to add small quantities of one or more gum-resins, such as sandarach, amber, and anime, to the lacquer, which is coloured with gamboge, dragon's blood, and other substances. The brass, which is first heated till the hand can just safely touch it, generally receives two coats of lacquer; but sometimes the first coat is put on when the metal is cold. In the case of dark lacquering the brass is first bronzed and coated with black lead. Coal and tobacco smoke, as well as the vapour or fumes of some chemical substances, injure lacquered surfaces.

Lacquer-ware.—The lacquer used for the celebrated lacquer-ware of Japan differs entirely from the lacquer used for brass. The body of this ware is of wood, and the lacquer or varnish with which it is coated is the juice of the lacquer-tree (*Rhus vernicifera*), sometimes also called the varnish-tree. This remarkable lacquer not only forms a very hard surface, but, unlike other varnishes, it stands a considerable heat without injury, so that in Japan lacquered vessels are used for hot soups and hot alcoholic drinks. There are numerous kinds of Japanese lacquer-ware, the simplest kind being perhaps that with the grain of the wood seen, for which a fine transparent lacquer is used. For black lacquer ware the juice or varnish is darkened with galls and a salt of iron, and for red it is mixed with about 20 per cent. of cinnabar; orpiment, oxide of iron, and Prussian blue being also used as colours. In the case of gold and silver lacquer-ware, the varnish is mixed with about 30 per cent. of the powder of these metals in a fine state of division, so that when the surface is polished it shows a metallic lustre. Tin is used to imitate gold, the yellow hue being given by colour in the varnish.

The lacquered surface of the best ware is prepared by a very tedious process, owing to the number of coatings it receives. For the several preliminary ones crude lacquer is used, together with a single coating of powdered bismit earthenware and water, the surface being rubbed with a whetstone after each. Two or three more coatings of lacquer are next applied, each being rubbed with charcoal and water. For the finishing coat the best lacquer is employed, and this is polished with calcined deer-horn, finely powdered, the finger and a little oil bringing up the final gloss. The various articles made, such as boxes, vessels, trays, cabinets, &c., are decorated either by inlaying with metal, ivory, or mother-of-pearl, by speckling and gilding with gold or silver, by designs in colour, by relief paintings, or by carving. The art of lacquering is a very ancient one in Japan, and fine specimens of old work bring very high prices.

Lacretelle, JEAN CHARLES DOMINIQUE DE, journalist and historian, was born at Metz on 3d September 1766. He was attracted to Paris on the outbreak of the Revolution; but there, instead of following his profession, that of an advocate, he turned his abilities to journalism, and helped to edit *Le Journal des Debats* and *Le Journal de Paris*. He managed to escape the Reign of Terror by enlisting in the army; but soon procured his release and returned to journalistic work in the capital. In 1810 he was nominated censor of the press, having the year previous been appointed professor of History in the university of Paris. This post he held down to 1853. From 1811 a member of the French Academy, he became its president in 1816. Lacretelle died near Mâcon on 26th March 1855. He wrote a series of works, respectable, but of no very outstanding merit, dealing with the history of France from the time of the religious wars down to the middle of the 19th century. Of these the most useful are *Histoire du Dix-huitième Siècle* (6 vols. 1808),

Précis Historique de la Révolution (3 vols. 1801-6), and *Histoire de France pendant les Guerres de Religion* (4 vols. 1814-16).—His elder brother, PIERRE LOUIS (1751-1824), distinguished himself as an advocate and journalist, and by his writings on law subjects.

Lacroix, PAUL, French miscellaneous writer, better known by his pen-name of P. L. JACOB, BIBLIOPHILE, was born at Paris, on 27th February 1806. Whilst still at school he began to edit editions of the old French classics, as Marot, Rabelais, &c. But it was in the field of the historical romance that he won his spurs as a writer. His industry was prodigious, and the number of works that issued from his pen immense. Besides actively assisting in more than one journalistic enterprise, he wrote romances, plays, books on history, on manners and customs, and on bibliography, and edited memoirs, biographies, &c. His most valuable productions were a series of works on the habits, manners, customs, costumes, arts, sciences, and intellectual condition of France from the middle ages down to the 19th century. His bibliographical works are also valuable, especially those in connection with Molière. He wrote two elaborate works on the *History of Prostitution*, published under the name of Pierre Dufour. From 1855 onwards Lacroix was custodian of the Arsenal library of Paris, and died in that city on 16th October 1884.

Lacroix, SYLVESTRE FRANCOIS, a French mathematician, was born in Paris in 1765, taught mathematics from 1787 in different educational establishments connected with the army, then in the Normal School, the Polytechnic, the University of France, and the Collège de France successively. He died on 25th May 1843. He is not remarkable for original discovery in mathematical science, but deserves to be remembered for his *Traité du Calcul Différentiel et Intégral* (Paris, 1797; 7th ed. 1867), and its continuation, *Traité des Différences et des Séries* (1800), which are complete compilations of the results of all previous research.

La Crosse, a Canadian field game played with a ball and a long stick (5 or 6 feet) of light hickory, bent at the top like a bishop's crozier (Fr. *crosse*). Strings of deer-skin are stretched diagonally across the hooked portion of the crosse in different directions, forming a network—not so tightly as in a battledore or tennis racquet, nor so loosely as to form a bag. Only one ball is employed, made of india-rubber, and 8 or 9 inches in circumference.



The Crosse and Ball.

Posts or poles about 6 feet high, with a small flag at the top of each, complete the equipment. The players are usually twelve on each side, but their number, as well as the distance of the goals apart, is nearly optional. The object of the game is for one side to drive the ball through their opponents' goal. The ball must not be touched with the hand or foot, but is scooped up from the ground with the bent end of the crosse, on which it is carried horizontally, while the player runs towards one of the goals, trying to dodge his antagonists. If it seems prudent, he pitches the ball off his crosse towards one of his own side who may be in a better position to carry it towards the goal. The players must not strike, trip up, or grasp one another, nor must any

one lay hold of the crosse of another; a player may strike the ball off an opponent's crosse with his own crosse, and not by any other means.

The National La Crosse Association of Canada was founded in 1867, and in the same year an Indian team visited Great Britain. Afterwards other Canadian teams played in England and Scotland, and several local clubs were formed; in a few places the game is very popular.

La Crosse, capital of La Crosse county, Wisconsin, stands on the Mississippi, at the mouth of La Crosse River, and at the junction of six railways, 195 miles by rail WNW. of Milwaukee. It contains a Roman Catholic cathedral and over a score of other churches, a convent, an orphanage, two hospitals, excellent schools, and a public library. The city has a large trade in lumber and grain. The manufactures include farming implements, engines and boilers, sashes and blinds, &c., and there are several large lumber-mills, iron-foundries, and breweries. Pop. (1870) 7785; (1890) 25,090.

Lacryma Christi, a wine of a sweet but piquant taste, and a most agreeable bouquet, which is produced from grapes grown on Mount Vesuvius. The kind most esteemed is the light red, the dark amber-coloured coming next. But the genuine wine is very expensive, as only a small quantity is produced; and the name (derived from a monastery on the mountain) is commonly given in Naples to Capuan and other second-class wines. See WINE.

Lactantius, LUCIUS CÆLIUS (or CÆCILIUS) FIRMIANUS, an eminent Christian apologist who flourished in the early part of the 4th century. His Italian descent is more than dubious, but it is certain that he was brought up in Africa, although it is very unlikely that he was a pupil of Arnobius. He seems to have settled as a teacher of rhetoric in Nicomedia in Bithynia, and most likely he was converted there by witnessing the marvellous constancy of the Christian martyrs under the tenth and most savage persecution of Diocletian. About the year 313 he was invited to Gaul by Constantine the Great, to act as tutor to his son Crispus, and is supposed to have died about 325. His principal work is his *Divinarum Institutionum libri vii.*, a production both of a polemical and apologetic character. His theology is somewhat crude, and he has been accused of error in his treatment of the doctrine of the Holy Spirit, his Chiliasm and his eschatology were not peculiar to himself. Among his other writings are treatises *De Ira Dei* and *De Mortibus Persecutorum*, both inscribed to his dear friend, the famous Donatus. His style is remarkably pure, justifying his title of the 'Christian Cicero.' His character appears to have been elevated but austere, perhaps somewhat soured by the poverty and trials of his life.

Lactantius was remarkably popular in the middle ages, and MSS. and printed editions of his works are numerous. Dufresnoy in his edition (2 vols. 1748) enumerates as many as 86 editions of his entire works, besides separate editions of his different treatises, from 1461 to 1739 A.D. The best editions are those in vols. x, xi, of the *Bibl. Pat. Eccl. Lat.* by Gersdorf (Leip. 1812-41), and Migne's *Patrologia* (vol. vi. 1844). There is a translation in Clark's Ante-Nicene Library.

Lactation. See MILK, BREAST.

Lacticals. See DIGESTION, Vol. III, p. 815.

Lactic Acid, $\text{CH}_3\text{CH}(\text{OH})\text{CO}_2\text{H}$, the acid contained in sour milk. In the pure state it is a colorless, transparent, syrupy liquid, of specific gravity 1.215. It is without smell, has a sharp acid taste, and is miscible with water, alcohol, and ether. It is formed in milk by the fermentation of the milk-sugar under the influence of an organised ferment. On a large scale it is usually prepared from

cane-sugar in the following manner: 7 lb. of cane-sugar and $\frac{1}{2}$ oz. tartaric acid are dissolved in 4 gal. of water and allowed to stand for a few days; then 4 oz. of rotten cheese rubbed up in a gallon of sour milk, and $2\frac{1}{2}$ lb. of zinc oxide (zinc white) are added, and the mixture is thoroughly stirred and kept at a temperature of about 105° F. for eight or ten days. The liquid is boiled to stop the fermentation, filtered, and evaporated till the zinc lactate which it contains crystallises; this is then re-dissolved in water, decomposed with sulphuretted hydrogen, the mixture filtered to free it from zinc sulphide, and evaporated on a water-bath.

Lactic acid occurs very widely distributed as a product of the natural fermentation of sour vegetable materials, such as sauerkraut; it is also found in the stomach and intestines. An isomeric acid of the same composition but slightly different properties, called sarco- or para-lactic acid, occurs as a product of waste of animal tissues, and is found in muscle of all kinds, especially after violent exertion or artificial tetanus. Sarco-lactic acid has been frequently detected in blood soon after its removal from the body, in quantities usually below 1 part per 1000, but it apparently does not occur in normal healthy blood while in the body.

The tests for lactic acid are not very satisfactory. On addition of lead acetate and alcoholic ammonia to a solution containing lactic acid an insoluble lead lactate, $3PbO \cdot 2C_3H_5O_2$, is precipitated as a white powder. The properties and amount of water of crystallisation of the zinc lactates are also characteristic. Most of the lactates are crystalline and soluble in water.

Lactometer, or GALACTOMETER, a very simple instrument for testing the richness of milk; it consists of a glass tube graduated to 100 parts. New milk is poured in up to the top of the graduated part and allowed to stand; and when the cream has completely separated the value of its quantity is shown by the number of parts in the 100 which it occupies. Another form of instrument was invented by Doeffel, consisting of a small hydrometer with a scale 2 inches long divided into 20 degrees, the zero being placed at the point to which the instrument sinks in water, and the 20th degree corresponding with the density 1.0383. This instrument is preferred by the continental chemists; and 14 is held to show milk undiluted with water.

Lactucarium. See LETTUCE.

Ladakh, one of the outlying governorships of Cashmere, in the valley of the Upper Indus, and behind the great central range of the Himalayas. The Ladakhis, some 20,000, are of Turanian stock and Buddhists in religion. The capital is Leh (q.v.). See CASHMERE.

Lad'amm (Arab. *lādun*; Gr. *lādanon*), a curious, delicately-scented, resinous gum which exudes from certain kinds of Cistus, chiefly *C. orientis*, *C. ladan*, and *C. laurifolius*, growing in Crete, Cyprus, and parts of Asia Minor. *C. ladaniferus*, strange to say, does not produce the gum. Ladannum, under the name of Labdamm, is alluded to by Browning in *Paracelsus*; and there are interesting articles under *Ladannum* and *Lade* in the French *Encyclopédie*, ix. 172 and 336, in which the gum is said to be collected on fringes of leather attached to long poles, and drawn over the shrubs in the heat of the day. In Cyprus at the present time the gum is actually collected from the beards of the goats that browse among the bushes, a system mentioned by Herodotus, iii. 112. At one time ladannum was used in medicine and as a perfume; it is now, in the form of small black balls, a costly toy fingered by soft handed idlers in the Levant.

Ladiu. See ENGADINE.

Lading. BILL OF. See BILL OF LADING.

Lado. See GONDOKORO.

Lad'oga, LAKE, the largest lake of Europe, is situated a short distance N. of St Petersburg, in Russia, being crossed by the frontier-line between that country and Finland. It is 129 miles in length, 78 in breadth, and 6998 sq. m. in area. The southern and eastern shores are low and marshy; but on the north-west the coast is broken, and rises into cliffs. There, too, are numerous islands. The lake receives the waters of Lake Omega and Lake Ilmen in Russia and of Lake Saima and other lakes in Finland; and its own waters are carried off to the Gulf of Finland by the Neva (q.v.). The average depth of Lake Ladoga does not exceed 300 feet, except in the north-west, where over a limited area the depth is about 730 feet. The navigation is exceedingly dangerous owing to the shallows, sand-banks, and sunken rocks with which the lake abounds, and to the winds and gales which prevail during the months it is free from ice (May-October). In order to obviate the difficulties of navigation, canals have been constructed to connect the mouths of the rivers that reach it along the south and south-east shores. The principal is the Ladoga Canal (70 miles long and 60 feet wide). This canal system forms the thoroughfare for a very extensive traffic (some 20,000 vessels annually, carrying merchandise valued at £6,000,000) between the Volga and the Baltic, so extensive, in fact, that the government have recently seen fit to construct a new canal parallel to the old Ladoga Canal. Communication by water subsists between Lake Ladoga and the White Sea as well as the Caspian. The fauna of the lake is arctic in character. Two of the islands in the north-west, Valaam and Konevets, are each the seat of a monastery, founded in 960 and 1393 respectively, which are visited by thousands of pilgrims every year.

Ladrones, or MARIANA ISLANDS, a group of fifteen islands in the western Pacific, north of the Carolines, in 13° 21' N. lat. and 144° 146' E. long., disposed in a row almost due north and south; their united area is about 420 sq. m. They were discovered by Magellan (1521), whose sailors called them the 'Thieves' (*Ladrones*) Islands, from the thievish propensity displayed by the natives; in 1668 they received the name of Mariana Islands. In 1899 they were sold by Spain to the United States. A channel divides the islands into two groups. The five to the south are low and flat, those to the north mountainous; most are thickly wooded, and all are well watered, fruitful in coconuts, rice, maize, cotton, sugar, tobacco, and indigo. The area cultivated, however, is small, and the trade is of little consequence. The people are mostly indigenous Chamorros and Tagals from Luzon, besides a mixed race of partly Spanish descent. At the time when the islands were discovered the inhabitants were reckoned at 60,000, but the present population is only about 8700. Under the Spanish rule their former gaiety and cheerful industry have changed to dull, apathetic indifference and laziness, and their heathenism to an outward Christianity which places no check on license and immorality. The largest island is Guam, with an area of 198 sq. m., and a pop. of nearly 7000; on it is the only town, Agaña.

Lady, a woman of distinction correlatively to *Lord* (q.v.), used in a more extensive sense in common parlance correlatively to *gentleman*. As a title it belongs to peeresses, the wives of peers and of lords by courtesy, the word *lady* being in all these cases prefixed to the peerage title. The daughters of dukes, marquises, and earls are by courtesy designated by the title *lady* prefixed to

their Christian name and surname; a title not lost by marriage with a commoner. 'Lady,' prefixed to their husband's surname, is the usual title of wives of Baronets (q.v.) and knights. See COURTSEY TITLES, ADDRESS (FORMS OF).

Ladybird (*Coccinella*), a genus of pretty little beetles, generally of a brilliant red or yellow colour, with black, red, white, or yellow spots. The form is nearly hemispherical, the under-surface flat, the thorax and head small, the antennae and legs short.



Ladybird (*Coccinella octulata*), magnified.

When handled they emit a yellowish fluid, with a disagreeable smell. Adults and larvæ feed chiefly on aphides, and are thus most useful to hop-growers and other agriculturists. The eggs are laid under the leaves of plants, on which the larvæ afterwards run about in pursuit of aphides. In late autumn the surviving adults find safe corners, and hiber-

nate till spring. Ladybirds occasionally occur in immense numbers, and from ignorance of their usefulness have sometimes been regarded with superstitious dread. The family of which the genus is type, Coccinellidae, includes about 1500 species, of which forty or so are British. One of the commonest forms (*C. septem-punctata*) is found over all Europe, and in parts of Asia and Africa. The name is apparently a modification of *Ladybug*, lady referring to the Virgin Mary, as the German name *Marienkäfer* suggests.

Lady Chapel, a chapel dedicated to the Virgin Mary ('Our Lady'), and usually, but not always, placed eastwards from the altar when attached to cathedrals. Henry VII.'s Chapel at Westminster is the lady chapel of that church.

Lady-day, one of the regular quarter-days in England and Ireland, on which rent is generally made payable. It is the 25th of March in each year; but in some districts Old Lady Day (April 6) is still observed as the term day. See ANXICATION.

Lady Fern (*Athyrium filix-femina*, or *Asplenium filix-femina*), a beautiful fern, common in moist woods in Britain, with bipinnate fronds sometimes two feet long. The whole plant has an extremely graceful appearance. It is said to possess the same anthelmintic properties as the male fern.

Lady's Mantle (*Alchemilla*), a genus of herb-



Alpine Lady's Mantle (*Alchemilla alpina*); a, a flower.

aceous plants, chiefly natives of temperate and

cold climates, of the natural order Rosaceæ, sub-order Sanguisorbeæ; having small and numerous flowers, an 8-cleft calyx, no corolla, and the fruit surrounded by the persistent calyx. The name lady's mantle, signifying *Mantle of Our Lady*, i.e. of the Virgin Mary—is derived from the form of the leaves.—The Common Lady's Mantle (*A. vulgaris*) is abundant on banks and in pastures throughout Britain. Its root-leaves are large, plaited, many-lobed, and serrated; its flowers, in corymbose terminal clusters, are usually of a yellowish-green colour.—The Alpine Lady's Mantle (*A. alpina*) grows on Scotch mountains, and has digitate serrated leaves, white and satiny beneath.—A common British plant is the Field Lady's Mantle, or Parsley Piert (*A.*—or *Aphanes—arvensis*), found in pastures, an astringent and diuretic, said to be useful in cases of stone in the bladder, by producing a large secretion of lithic acid.

Lady's Slipper (*Cypripedium*), a genus of plants of the natural order Orchidææ, of which one species, *C. Calceolus*, is a native of Britain, being found in a few places in the north of England, and is reckoned one of the most beautiful of the British orchids. The genus is remarkable for the large



a, *Cypripedium spectabilis*; b, flower and leaf of *C. barbatum*.

inflated lip of the corolla. Several very beautiful species are natives of the colder parts of North America. *C. spectabilis* is a North American species; *C. barbatum*, a native of Java. Both are in cultivation, the former in hardy collections, the latter in hothouses.

Ladysmith, a small town in Natal (named from a colonial governor's wife), 140 miles N.W. of Durban by rail. On the outbreak of the Transvaal War in 1899 it, including the army of Sir George White, was invested by the Boer forces, and after a siege of one hundred and twenty days, was finally relieved by Sir Redvers Buller on 28th February 1900. Pop. about 2000.

Laeken, a northern suburb of Brussels, with (1891) 25,211 inhabitants. In it is the crypt of the Belgian royal family in the new Gothic church of the Virgin, and a royal palace (built in 1782), which previous to its destruction by fire on 1st January 1890 contained valuable works of art and historical documents. The palace has been rebuilt in the same style as the one destroyed.

Laennec, RENE, THEODORE HYACINTHE, a distinguished physician, was born at Quimper, in Lower Brittany, 17th February 1781. He studied medicine under his uncle at Nantes, and at Paris

under Corvisart, to whom the medical profession is mainly indebted for the introduction of percussion in the investigation of diseases of the chest (although the original discovery is due to Auenbrugger). In 1799 Laennec was an army-doctor in the field; in 1814 he became the chief editor of the *Journal de Médecine*; in 1816 he was appointed chief physician to the Hôpital Necker, and it was there that he soon after made the discovery of 'mediate' auscultation, or, in other words, of the use of the Stethoscope (q.v.). In 1819 he published his *Traité de l'Auscultation Médiate*, which has undoubtedly produced a greater effect, in so far as the advance of diagnosis is concerned, than any other single book. His treatise had not long appeared when indications of consumption were discovered in his own chest by means of the art of his own invention, and after a few years of delicate health, during which he continued to practise in Paris, he retired to die in his native province, 13th August 1826. See his *Life* by Lallour (Quimper, 1868).

Lafare Sunday. See GOLDEN ROSE.

Lævulose. See SUGAR.

Lafayette, capital of Tippecanoe county, Indiana, on the Wabash River, and on the Wabash and Erie Canal, 63 miles NW. of Indianapolis, at the intersection of five railways. It is a flourishing city, in the midst of a rich prairie country. Laid out in 1825, it contains numerous churches, the Purdue state university, and manufactories of farming-implements, machinery, cars and wagons, &c. Pop. (1880) 14,860; (1890) 16,243.

La Fayette. MADAME DE, the reformer of French romance-writing, was born in 1634, her father being a marshal and governor of Havre. She married the Comte de La Fayette in 1655, and was a member in her youth of the literary circle which met in the Hôtel de Rambouillet. She was the intimate friend of Mme de Sévigné, and in her thirty-third year formed a liaison with La Rochefoucauld, which lasted until his death in 1680. She died in 1693. Her novels *Zuile* and the *Princesse de Cleves* led to a reaction in taste against the fantastic and long-winded romances of such writers as La Calprenède and Mlle de Scudéry. She had a genuine command of passion and knowledge of character, and in her *Princesse de Cleves* gave a vivid and faithful picture of the court life of her day. She committed, however, a curious anachronism in transferring the men and women of Louis XIV.'s age to the court of Henry II.; for example, her Duchesse de Valentinois is Mme de Montespan, the Prince de Cleves is the Comte de La Fayette, and the Duc de Nemours is La Rochefoucauld. Her novels, says Geruzez, were more than a novelty, they were almost a revolution. Her *Œuvres Complètes* till 5 vols. (1812; new ed. 1882); of her *Mémoires* the best ed. is by Assé (1890). See Haussouville's monograph (1891), and Ste-Benve's *Portraits de Femmes*.

Lafayette, MARIE JEAN PAUL ROCH YVES GILBERT MÔTIER, MARQUIS DE, was born in the castle of Chavagnac, in Auvergne, September 6, 1757. He belonged to an ancient family; came to his estates at thirteen; married three years later; entered the army, and sailed, in spite of the at least professed opposition of the court, for America in 1777, to offer his sword to the colonists in their struggle for independence. He became an intimate and admiring friend of Washington, who gave him the command of a division after his conduct at the battle of Brandywine. The treaty between the insurgents and France at once led to war between France and England, and Lafayette returned to his country early in 1779. Six months later he again crossed the Atlantic, was charged with the defence of Virginia, and had his share in the battle of Yorktown, which practically closed the war. On

a third visit to North America in 1784, after the conclusion of peace, he was received in such a manner that his tour was a continual triumph.

Lafayette had imbibed liberal principles in the freer air of America, and was eager for reforms in his native country. He was called to the Assembly of Notables in 1787, and sat in its successor, the Assembly of the States General, and in that which grew out of it, the famous National Assembly of 1789. He took a prominent part in its proceedings, and laid on its table, on the 9th July 1789, a declaration of rights based on Jefferson's Declaration of Independence. He was soon appointed to the chief command of the armed citizens, whereupon he formed the National Guard, and gave it the tricolor cockade. Indeed, in the first stages of the Revolution, it seemed as if the 'Grandison-Cromwell-Lafayette' had the destinies of France in his hands. But the fever of revolution soon surged too hotly for the constitutional channels in which he would have had it flow. He struggled incessantly for order and humanity, yet was mortified to the heart by the furious violence of the mob which butchered Foulon and brandished the reeking heart of the commandant Berthier before his eyes. The Jacobins hated his moderation, while the court abhorred his reforming zeal, and both combined to defeat him in his canvass against Pétion for the mayoralty of Paris. Along with Bailly he founded the club of the Feuillants, and he supported the abolition of title as well as of all class privileges. After the adoption of the constitution of 1790 he retired to his estate of Lagrange till he received the command of the army of Ardennes, with which he won the first victories at Philippeville, Maudenge, and Florennes. But the hatred of the Jacobins increased, and at length Lafayette, who had come from the army to Paris publicly to denounce the Jacobin Club, finding on his return to the camp that he could not persuade his soldiers to march to Paris to save the constitution, rode over into the neutral territory of Liège. He was seized by the Austrians and imprisoned at Olmütz till Bonaparte obtained his liberation in 1797; but he took no part in public affairs during the ascendancy of Bonaparte. He sat in the Chamber of Deputies from 1818 to 1824 as one of the extreme Left, and from 1825 to 1830 he was again a leader of the opposition. In 1830 he took an active part in the revolution, and commanded the National Guards. In 1824 he revisited America, by invitation of Congress, who voted him a grant of 200,000 dollars and a township of land. He died at Paris, 20th May 1834.

See his *Mémoires et Correspondance* (8 vols. 1837-40); studies by Regnault Warn (1824) and Sarrane (1832); *Life* by B. Tuckerman (New York, 1889); two books by Bardoux (1892); the *Diary and Letters of Gouverneur Morris* (1888); and Domiel's *Participation de la France à l'Établissement des États Unis* (1889-91).

Laffitte, JACQUES, a French banker and statesman, born at Bayonne, 24th October 1767, began life as a banker's clerk in Paris, and in 1805 began business on his own account. He soon acquired great wealth and in 1814 was made governor of the Bank of France. After the second restoration he joined the opposition in the Chamber of Deputies, and enjoyed the highest popularity in Paris; he was elected by all twenty sections in the city in 1817. In 1830 he made his house the headquarters of the friends of the revolution, and out of his private means supplied great part of the funds for carrying through the movement. In November he was entrusted with the formation of a cabinet, but he only held power until 12th March following. Meanwhile he was obliged to sell his property to pay his debts. A national subscription preserved him his hotel in Paris; and from the

ruins of his fortune he founded a new Discount Bank in 1837. As the government receded from the principles of the revolution of 1830, Laffitte became more and more active in opposition. In 1843, to the great displeasure of the court, he was elected president of the Chamber of Deputies. He died at Paris, 26th May 1844. The *Souvenirs de J. Laffitte, racontés par lui-même* (3 vols. Paris, 1844), were written by Marchal.

Lafite. See BORDEAUX.

Lafontaine. JEAN DE, was born on July 8, 1621, at Chateau-Thierry, in Champagne. His early education was neglected. He was placed in a clerical seminary, which he soon quitted to undertake his father's duties as master of woods and forests. Early in life he devoted himself to the study of Rabelais, Marot, and other old writers, and set himself to the composition of verses—all of them more or less worthless. In 1654 he published a verse translation of the *Eunuchus* of Terence, and then went up to Paris, where he won the favour of Fouquet, who awarded him a pension of 1000 francs on condition that he furnished a piece of verse quarterly. The verses thus produced showed considerable originality, and their author became the darling of the ladies of highest distinction in Paris. During six years he wrote little, abandoning himself to a life of gallantry and to social meetings with Molière, Boileau, and Racine. His *Contes et Nouvelles en Vers* appeared in 1665; his *Fables Choisies mises en Vers* in 1668; and his *Amours de Psyche et de Cupidon* in 1669. Among his chief patronesses were Marguerite of Lorraine and the Duchess of Bonillon, and for nearly twenty years he was maintained in the household of Mme de la Sablière. In 1684 he read an admirable *Discours en Vers* on his reception by the Academy, to which he was admitted much against the wish of the king. In her later years Mme de la Sablière became devout, but Lafontaine attached himself to the dissolute Prince de Conti, pursuing in his old age the follies and dissipations of his youth. She died in 1693, and for his two remaining years he was cared for by Mme d'Hervart, who maintained him until his death, which occurred at Paris on April 13, 1695. During an illness about two years before he had allowed himself to be converted in so far at least as to acknowledge the impropriety of the *Contes* and, it is said, destroy a new play. He was one of the idlest, the most reckless, the most frivolous and dissipated of men, but he was likewise one of the most lovable and charming, as he was assuredly one of the most gifted.

The subjects of the *Contes* are taken from Boccaccio, Ariosto, Machiavelli, Rabelais, the *Heptameron*, the *Cent Nouvelles nouvelles*, Apuleius, Athenæus, and other writers. The stories are retold with inimitable skill, Lafontaine surpassing in wit and in narrative dexterity the authors with whom he challenged comparison. Nothing could be easier, more sparkling, more ingeniously and gracefully turned than his verse. The language has a racy archaic flavour, the style combining the elegance of the 17th century writers with something of the Rabelaisian richness. The subjects are nearly all of the grossest description, and their grossness is in most cases artfully heightened by Lafontaine. His story of Alaciel, for example, is a deeply degraded version of the sombre though voluptuous tale told by Boccaccio. As for the *Fables*, their charm is undying, and they are free from the impropriety of the *Contes*. It has been truly said of them by Silvestre de Saey that they supply three several delights to three several ages. 'The child rejoices in the freshness and vividness of the story; the eager student of literature in the consummate art with which it is told; the experienced man of the

world in the subtle reflections on character and life which it conveys.' Nevertheless the general verdict of French critics on Lafontaine can hardly fail to seem unduly high to his English readers. Theodore de Banville, for example, maintains that he is not merely an artist supreme in lyric comedy, but a great romantic poet, in whose work there is always a 'window open to heaven.' Such praise is hardly judicious. Lafontaine was a sparkling satirist, a brilliant versifier, a well-nigh incomparable master of the difficult art of telling a story in rhyme. He combined, as another critic has said, the flower of the *esprit Gaulois* with a perfume of antiquity. He was a great—not merely an amusing—writer, but he was not a great poet. With all its graces, his verse has not the melody, the passion, the power of suggesting a beauty and mystery beyond the exact meaning of the words, which distinguish all high lyric work. But on the other hand it would be hard to name a French poet, saving Molière, who has given such delight to others than his countrymen as has been given by Lafontaine.

See Sainte-Beuve's *Portraits Littéraires*, vol. i.; Banville's *Petit Traité de Poésie Française*; Taine's *Essai sur les Fables de La Fontaine*; and Lucas Collins' *La Fontaine and other French Fabulists* (1882). The best editions are by Marty-Laveaux in the *Bibliothèque Elzévirienne*; A. Pauly in Lemerre's *Collection des Classiques Françaises*; L. Moland in the *Librairie des Bibliophiles*; and Girard and Destenilles in the *Grands Écrivains*.

Lago Maggiore. See MAGGIORE.

Lagomys, a genus of rodents, much resembling hares or rabbits, but with limbs of more equal length, more perfect clavicles, longer claws, longer head, shorter ears, and no tail. There are about a dozen species, one in south-east Europe, one on the Rocky Mountains, and the rest on the mountains of northern Asia. They are about the size of guinea-pigs, and make burrows, but are particularly interesting for their habit of stacking choice herbage for winter use. The stacks of the Siberian species, the Alpine Lagomys or Pika (*L. alpinus*), are said to be utilised by the sable-hunters for fodder.

Lagoon (Lat. *lacuna*, 'a hollow,' 'a pool') is a species of lake formed by the overflowing either of the sea or of rivers, or by the infiltration of water from these; and hence lagoons are sometimes divided into fluvial and marine. They are found only in low-lying lands, such as the coasts of Holland, Italy, the Baltic, and the east coast of South America; are generally shallow, and do not always present the same aspect. In some cases they are completely dried up in summer; in others, after being once formed, they preserve throughout the whole year the character of stagnant marshy pools; and in others again the sea, which reunites them to itself in winter, is separated from them in summer by a bar of sand or shingle.

Lagos, a seaport on the south coast of Portugal, 30 miles ENE. from the extremity of Cape St Vincent. Pop. 7900, who fish for tunny and sardines. In the bay of Lagos Admiral Boscawen defeated the French Toulon fleet, August 18, 1759.

Lagos, a British colony, an island, and a town on the Guinea coast of Africa. The colony extends from 2 to 6 E. long., and comprises the islands of Lagos and Iddo (annexed in 1851), the districts of Palma and Lockie (1862), district of Badagry (1863), Katamu (1879), Appa (1883), and Malim, Ogho, and Jakri (1885). Area of colony, 1971 sq. m. The inhabitants (85,607 in 1891) are mostly Negroes and two thirds pagans, though Mohammedanism is making great headway. Average annual value of exports (palm oil, palm kernels, ivory, gum copal, cotton, and Guinea grains), £582,040; of imports (spirits, tobacco, cotton goods, and hardware), £466,370. Trade is carried on principally with

England and Germany, to a less extent with the United States, France, and Brazil. The island has an area of 3½ sq. m.; and at its western end stands the town, the principal commercial place on this part of the coast, and the only safe harbour for a distance of 1000 miles. Pop. 40,000. The bishop of the Niger territory resides here; but Lagos itself belongs to the diocese of Sierra Leone. Previous to the interference of the British Lagos was one of the chief entrepôts for the export of slaves. Created a separate government in 1863, the colony formed part of the West African Settlements (from 1866) and of the Gold Coast (from 1874) successively. In 1886 the present colony was constituted.

Lagostomus. See CHUNCHILLA.

Lagrange, JOSEPH LOUIS, COMTE, the great algebraist, was born at Turin, 25th January 1736. His father, who, as well as his mother, was of French descent, was war-treasurer to the Piedmontese government. In later life Lagrange explained his first application to the study of mathematics by the fact that the family property had been lost in speculations. At the age of seventeen a paper of Halley's in the *Philosophical Transactions* turned him towards algebra and analytical geometry, and then his powers developed with striking precocity. In 1751 he was appointed mathematical professor in the Royal School of Artillery; at the same time he discovered a series for differential expansion analogous to the binomial theorem of Newton, and attracted Euler's attention by a letter on the general solution of certain isoperimetric problems which had been proposed to the best mathematicians in Europe. He also corresponded with D'Alembert, then the leader of French scientific society. At Euler's suggestion Frederick the Great appointed Lagrange to succeed him as director of the Academy of Berlin. Before leaving Piedmont he did much original work in integration and partial differences, applying mathematical methods to physics and astronomy, and assisted, in 1758, to found the Turin Academy of Sciences. In 1762, by his completion of the Calculus of Variations, the main theory of which had been foreshadowed in his discussion of isoperimetricals, and his investigations of sound, harmonies, &c. by new analytical methods, Lagrange gained a European reputation, though at the expense of his health, which was never afterwards robust. His memoir on the moon's libration, which in 1764 obtained the prize of the French Academy, brought into prominence his great principle of virtual velocities, which was presently to be so largely utilised in dynamical problems. Lagrange gave the first complete proof of Laplace's generalisation, that, so far as the laws of motion are concerned, our solar system is necessarily stable and permanent, because all the changes of the planetary orbits, caused by their reciprocal gravitation, are periodic. While in Prussia, from 1766 to 1787, Lagrange read before the Berlin Academy about sixty dissertations on the application of the higher analysis to mechanics and dynamics. From the leading results of these memoirs and of his previous work, duly marshalled and systematised, arose Lagrange's principal work, the *Mécanique Analytique*, which was published (1788) in Paris under the supervision of Legendre. The central theory, unifying the science of dynamics in all its developments, was the principle of virtual velocities which he had established in 1764.

Just before the issue of the *Mécanique Analytique*, Lagrange arrived in Paris, to be welcomed by the court and lodged in the Louvre with a pension of 6000 francs. In 1791 he was elected foreign member of the Royal Society of London.

He commanded universal respect even in the crisis of the Revolution, and was appointed professor in the Normal and Polytechnic Schools, one of the first members of the Bureau des Longitudes, and was enthusiastically in favour of the new decimal and metrical system. He was appointed member of the senate under Bonaparte, who also bestowed on him the title of Count and the Grand Cross of the Legion of Honour. He did more than any other, except Euler, to develop the applications of the infinitesimal calculus.

Partly owing to his weak constitution, Lagrange was extremely regular in his habits, abstemious in food, with his work ever most systematically distributed. His various treatises, read to the Academies of Turin, Berlin, and Paris, now fill seven quarto volumes. Other important works are *Théorie des Fonctions* (2d ed. 1813), *Leçons sur le Calcul des Fonctions, Résolution des Équations Numériques*. Lagrange died at Paris, 10th April 1813, and was buried in the Panthéon. A new edition of his works, in 16 vols., was undertaken in 1867.

La Guaira. See GUADRA.

La Hague, the north-west extremity of the peninsula of Cotentin, in the north of France, over against Alderney of the Channel Islands. It is crowned by a lighthouse, 158 feet high. This must not be confounded with La Hogue (q.v.).

La Harpe, JEAN FRANÇOIS DE, French writer, born at Paris, November 20, 1739, first attracted attention in 1763 by a successful tragedy, *Warwick*. His fame was further enhanced by a series of eloquent *Eloges*. But his other plays on the classic model, such as *Timoleon*, *Pharamond*, and *Gustave Wasa*, entirely failed. *Mélanie*, *Philotele*, and *Coriolan* were more successful. His best-known works are, however, his critical lectures, published in 12 vols. (1799-1805) as *Lycée, ou Cours de Littérature*, which long remained a standard of literary criticism. That portion which relates to ancient literature is of little value, and that which treats of contemporary writers is entirely worthless, owing to the bitterness and pride of the critic; but the intervening portion gives a fairly complete critical history of French literature. His *Correspondance Littéraire*, published in 1801, by the bitterness of its criticisms rekindled fierce controversies. The Revolution, at its commencement, found no more ardent admirer than La Harpe; but after five months' imprisonment for refusing to countenance the extremes to which the immoderate zealots of the movement pushed matters his views entirely changed, and he became a firm supporter of church and crown. A posthumous work, *La Vision de Cazotte*, must be ranked amongst the best achievements of his pen. His graceful style and keenness of observation are perhaps more than counterbalanced by his partiality, vehemence of judgment, and superficiality. La Harpe died February 11, 1803. See Sainte-Beuve, *Causeries du Lundi*, vol. v.

Lahn, an important affluent of the Rhine (q.v.) in its middle course.

La Hogue, a roadstead on the east side of the peninsula of Cotentin, in the north of France (not to be confounded with Cape La Hague, q.v.). On May 19, 1692, the French fleet of forty-four sail under Tourville, which Louis XIV. had collected for the purpose of invading England in support of James II., was defeated here by the combined English and Dutch fleets of ninety vessels under the Jacobite Admiral Russell. Twelve large French line of battle ships which took refuge in the shallow roadstead of La Hogue were destroyed, under the eyes of King James, by boats' crews led by Admiral Rooke. See Macaulay's *History*.

Lahore, capital of the Punjab, stands in 31° 34' N. lat. and 74° 21' E. long., near the left bank of the Ravi. Pop. (1868) 125,413; (1891) 176,854, of whom 86,413 were Mussulmans. Lahore covers 640 acres of ground, and is surrounded by a brick wall 16 feet high. The city is entered by metalled roads through thirteen gates. The fort occupies a commanding position to the north-east, and near it are the mosque of Aungzeb and Runjeet Singh's tomb. The English civil station, some 3 miles long, is called Anarkalli, and a broad road, the Mall, connects this with the government house and the Lawrence Gardens. Three miles farther is the military station or cantonment of Mian Mir, one of the dreariest and most unhealthy in India. The Punjab University, largely endowed by native chiefs and gentlemen—Moslem, Sikh, and Hindu—is one of the most flourishing educational establishments in India. There are also the Oriental College, the Government College, Government Medical School, Mayo Hospital, the Roberts Institute, and a good museum containing many fine specimens of Greco-Bactrian sculpture.

The origin of Lahore is uncertain, but is certainly not later than the 7th century A.D. Under the Mogul empire the city reached its greatest size and magnificence, and is said to have had a population of over 1,000,000 souls. Akbar and Jahangir lived at Lahore, and the remains of the beautiful and magnificent buildings erected by them and other great Mogul emperors are still considerable, as well as Jahangir's wonderful gardens at Shadra and Shalimar. Since the time of Aungzeb nothing of importance has been constructed. In 1799 Ranjeet Singh, the Sikh ruler of the country, removed the seat of government to Amritsar, about 30 miles to the south; but in 1846 a British Council of Regency (of the Punjab) was established in Lahore, in 1849 the young Maharaja Dhuleep Singh transferred the government of the state to the East India Company, and Lahore became the capital of the new British province of the Punjab. Lahore is an important railway centre; lines from Kurrahee and Peshawar are connected there with the south road leading to Delhi and Rajputana, to Calcutta, and to Bombay.

The Lahore district is one of the most important of the Punjab, with an area of 3648 sq. m., and a population of above a million. The Bari Doab Canal is an important government irrigation work, and no less than 500,000 acres in the district are cultivated by means of artificial irrigation of some sort.

Lahr, a town of Baden, on a small affluent of the Rhine, 20 miles SSE. of Strasburg by rail, with manufactures of cottons, pottery, &c., and printing establishments. Pop. 9937.

Laibach, capital of the Austrian crown-land of Carniola, and formerly of the Kingdom of Illyria, lies in an extensive plain on the river Laibach, 7 miles above its junction with the Save, and 92 by rail NE. of Trieste. The streets of the old town, which goes back originally to Roman times, are narrow and irregular, those of the new suburbs wide and handsome. The town was fortified from 1416 down to the beginning of the 19th century. The castle is now used as a prison. Laibach has been a bishop's see since 1461, and has a cathedral, national museum, &c. It is likewise a place of some commercial and industrial importance, having cotton factories, bell and iron foundries, cloth and woollen goods manufactories, and an imperial tobacco-factory. To the south-west of the town is the Laibach Morass upwards of 89 sq. m. in extent, three fourths of which have been brought under cultivation; the remainder affords a supply of turf. Interesting lake-dwellings have been discovered in the morass. Pop. (1890) 30,565. A

congress met here in 1821 to regulate the affairs of Italy.

Laidlaw, WILLIAM, the friend and latterly amanuensis of Sir Walter Scott, was born at Blackhouse in Selkirkshire in November 1780. After farming with but little success at Traquair and Libberton, he settled in 1817 as a kind of factor and manager on the estate of Abbotford and was Scott's trusted counsellor in all his schemes of improvement. Here, with the exception of but three years after the disaster in Scott's affairs, he lived till Scott's death in 1832, his constant companion and household friend, honoured by an affection that his loyalty deserved. Laidlaw's acquaintance with Scott began in the autumn of 1802, and he supplied some of the materials for the third volume of the *Minstrelsy of the Scottish Border*. The sweet and simple pathos of his own ballad, 'Lucy's Flittin', would alone have kept the name of 'Willie' Laidlaw from being forgotten even were that name not safely enshrined in a hundred pages of Lockhart's *Life of Scott*. After his great master's death Laidlaw was factor successively on two Ross-shire estates, and died at his brother's farm at Contin in that county, 18th May 1845. See two papers in *Chamber's Edinburgh Journal* for July 26 and August 2, 1845.

Laing, DAVID, a learned antiquary, was the son of an Edinburgh bookseller, and was born in 1795. For thirty years he followed his father's trade, earning the esteem of all the antiquaries and scholars of his time by his remarkable knowledge and his readiness to communicate it. In 1837 he became librarian of the Signet Library, a post which he held till his death, October 18, 1878. Laing was honorary secretary of the Bannatyne Club throughout, and himself edited many of its issues; while his contributions to the *Transactions of the Society of Antiquaries of Scotland* were innumerable, yet all stamped with characteristic thoroughness. He received the degree of LL.D. from Edinburgh in 1864, and left behind him a private library of unusual value even for his exceptional opportunities; many books at the sale in London realised unheard-of prices. A valuable collection of MSS. was bequeathed to Edinburgh University.

David Laing's knowledge of the ecclesiastical and literary history of Scotland was profound, and his more important works will long retain their value. These were his edition of Robert Baillie's *Letters and Journals* (3 vols. 1841-42), the works of John Knox (6 vols. 1846-64), and of the Scottish poets, Sir David Lyndsay, Dunbar, and Henryson. His literary life covered the long period of more than sixty years, and death surprised him busy on Wynton and a new edition of Lyndsay.

Laing, MALCOLM, a meritorious Scottish historian, was born on the mainland of Orkney in 1762. He was educated at Kirkwall and Edinburgh University, and was called to the bar in 1785, but never became a successful advocate. He died in November 1818. He wrote in 1793 the last volume of Henry's *History of Great Britain*, and in 1800 published his own *History of Scotland from James VI. to Anne*. In the 1801 edition occurs his attack on Queen Mary for participation in Darnley's murder. His *Poems of Ossian* is a fierce onslaught on Macpherson.

Laing's Nek. See COLLEY.

Lairesse, GERARD (1640-1711), a Dutch painter with classical sympathies, exercised an influence on art schools through his *Art of Painting* (Eng. trans. 1738). This work was compiled from notes of his conversations with friends and pupils after he had become blind (in 1690).

Lais, the name of one or, more probably, two Greek courtesans, celebrated for extraordinary

beauty. The elder is believed to have been born at Corinth, and flourished during the Peloponnesian war. She was supposed to be the most graceful woman of her time in Greece, but in character she was capricious, and greedy of money, and in her old age she gave way to intemperance.—The younger appears to have been born in Sicily, but came to Corinth when still a child. She sat as a model to the painter Apelles, and is said to have been stoned to death by some Thessalian women whom she had made jealous.

Laissez Faire is a phrase which expresses the attitude towards the State of the school of political economists founded by Adam Smith. The phrase is usually traced to Gournay, merchant and economist of the Physiocratic school. But it is said first of all to have been the remonstrance of French merchants against the system of the great statesman Colbert, who established a minute regulation of industry by the State. They believed that the best thing the State could do for industry was to leave it alone. The phrase therefore embodied the protest of private industrial enterprise against minute vexations, and oppressive regulation by a French state, which at that time represented only the court and a narrow privileged class, which was often incapable, and always engrossed in war, intrigue, and other pursuits alien to industry. But in England more than any other country it has been accepted as a watchword of free trade and free industry, as contrasted with the protective system and state regulation generally.

Laké, GERARD, Viscount, born 27th July 1744, served in Germany (1760), America, and at Vinegar Hill (1798). He defeated the forces of Gwalior at Alighah and Delhi (1803), Sindia at Leswarree (1803), and Holkar near Furruckabad (1804). Created a baron (1805) and viscount (1807), he died in London, 20th February 1808.

Lake (Lat. *lacus*) is a portion of water surrounded by land. Lakes are of two kinds—fresh water and saline—and have been formed in various ways. Taking first the *freshwater lakes*, these may be grouped as follows: (1) *Obstruction Lakes*.—Some of these are more or less temporary sheets of water, such as the lake-like expansions of certain rivers, and the deserted loops of river-channels. Other temporary lakes are due to the operations of the beaver; to the choking of the narrower passages of a river channel by drifted vegetable debris or river-ice; or to the advance of a glacier across the mouth of a lateral valley. Now and again rock-falls and landslips obstruct the drainage of valleys and give rise to lakes; and similar results have been brought about by the advance of lava across a valley. (2) *Crater Lakes*.—These occupy the craters of extinct or quiescent volcanoes. (3) *Sink Lakes*.—These lie in hollows caused by subsidence of the surface consequent upon the removal of underlying soluble rocks, such as rock-salt, and calcareous and gypsiferous rocks. (4) *Earth-movement Lakes*.—Unequal movements or warping of the earth's crust have occasionally originated hollows by direct subsidence. It is possible also that local elevation by affecting the lower ends of valleys may sometimes have obstructed the flow of rivers, and thus given rise to lakes. (5) *Glacial Lakes*.—These consist of (a) hollows of erosion or *rock-basins*, which have been excavated by glacier-ice, and (b) hollows caused by the unequal distribution or accumulation of glacial detritus during the glacial period. (6) *Subterranean Lakes*.—These are found chiefly in calcareous regions, where they occupy the underground channels which have been excavated by the chemical and mechanical action of water (see CAVES). They are met with also in volcanic regions, filling, or partially filling, the

cavities which are sometimes seen in lava-flows (see LAVA).

Fresh-water lakes are very unequally distributed. They are most numerous in those regions which were overflowed by land-ice during the glacial period, as in the British Islands, Scandinavia, Finland, &c., Canada, and the adjoining United States. Lakes occur at all heights above the sea; the most elevated being Lake Tsuna in Abyssinia (7500 feet), Lake Titicaca in the Bolivian Andes (12,500 feet), and Askal Chin in Tibet (16,600 feet). The largest lake in the world is Lake Superior, which covers an area of 31,200 sq. m., and has a mean depth of about 475 feet. Lake Baikal, in central Asia, is the largest and deepest mountain-lake, its area being 13,500 sq. m., and its mean depth 850 feet, but in places it reaches a depth of more than 4000 feet. Some of the mountain-lakes of Europe also attain great depths; thus, Lake Geneva is 1000 feet, Lago Maggiore 1158 feet, and Como 1358 feet.

Salt Lakes.—Two kinds are recognised: (a) portions of the sea cut off from the general oceanic area by epigene or hypogene agencies; (b) lakes, originally fresh-water, which have been rendered saline by evaporation and concentration. Those of the first group range in size from mere pools and lagoons up to inland seas, such as those of the great Aralo-Caspian depression. The Dead Sea and the Great Salt Lake of Utah are good examples of the second group of saline lakes, which might be defined shortly as lakes which have no outlet to the ocean. The Caspian Sea is 97 feet below the level of the Black Sea, has an area of about 170,000 sq. m., and is from 2500 to 3000 feet deep in the deepest parts. A still more depressed area is that of the Dead Sea, the surface of which is 1292 feet below the level of the Mediterranean Sea.

Lake District, the name applied to the picturesque and mountainous region comprised within the counties of Cumberland, Westmorland, and a small portion of Lancashire, within which are grouped as many as sixteen lakes or *meres*, besides innumerable mountain *tarns* and streams, and a series of mountains rising in four points to a height of over 3000 feet. The district extends about 30 miles from north to south by about 25 from east to west, and contains within its compass the utmost variety and wealth of natural scenery, soft and graceful beauty ever alternating closely with grandeur and sublimity. Indeed nowhere else in the world perhaps is so much varied beauty to be found within so narrow a space. The district is visited every year by thousands of tourists, who are able, from Keswick or Ambleside as a centre, to explore the whole region, and climb all its chief mountains within a week. But it must not be forgotten that many of the most lovely spots lie out of the ordinary routes, and that for those travellers who can afford the time there is ample occupation for a much longer period. The Lake District is fringed by such considerable towns as Penrith, Kendal, Lancaster, Barrow, Cocker-mouth, and Whitehaven; and already railways bring the traveller, from different points of the compass, to Keswick, to Windermere, to Coniston, and to Boot. The principal lakes are Windermere, Esthwaite Water, and Coniston in the south; Ulswater and Hawes Water in the east; Bassenthwaite in the north; West Water, Emmerdale Water, Buttermere, and Crummock Water in the west; and Derwentwater, Thirlmere, Grasmere, and Rydal Water in the heart of the district. The highest mountain-summits are Seafell Pike (3210 feet), Seafell (3161 feet), Helvellyn (3118 feet), and Skiddaw (3060 feet), all easily accessible, in great part even on pony-back. Besides these there are hundreds of mountains and *pikes* , many clothed with

the richest greenery. The lakes are fed and emptied by beautiful mountain-streams and *becks*, often forming noble waterfalls and *fores*, like Lodore Falls, near Derwentwater; Dungeon Gill Falls, near Grasmere; Stockgill Foree, near Ambleside; Seale Foree, near Crummoek Water; Aira Foree,

observation as a memorial of Wordsworth. His lifelong friend and brother poet, Southey, lived for forty years at Greta Hall, near Keswick, and rests in Crosthwaite churchyard hard by. Here also at Greta Hall Coleridge lived awhile, often visiting the Wordsworths; and here his children were brought up by Southey. The hapless Hartley Coleridge lived long at Nab Cottage, near Rydal Water, and is buried beside Wordsworth in Grasmere. Christopher North lived at Elleray, near Windermere; Shelley lived some time at Keswick after his marriage, and Mrs Hemans at Dove Nest on Windermere. Harriet Martineau had her home at the Knoll, near Ambleside; and not far off is Fox How, where Dr Arnold found rest from the strain of Rugby, and where he died. James Spedding was born at Bassenthwaite, and here was visited by Edward Fitzgerald and Tennyson; and the latter lived some time at Tent House on the east bank of Coniston Lake. At Brantwood, near Coniston Lake, Ruskin resided during the later years of his life. The poet Gray spent a fortnight of 1769 in traversing the Lake District, and his *Journal* shows that he looked before his time at nature with 'distinctness and unaffected simplicity,' in Wordsworth's phrase. Hither came in the summer of 1802 Charles Lamb, with his sister Mary, to spend three weeks with Coleridge at Keswick. He appears to have thoroughly enjoyed the new experiences, yet in a letter to his friend Manning (24th September 1802) he writes with a spirit worthy of Dr Johnson: 'After all, Fleet Street and the Strand are better places to live in for good and all than amidst Skiddaw.'



near Patterdale; and Dalegarth Foree, near Boot. Among the places most visited, besides these, are the towns or villages of Keswick, Coniston, Bowness, Hawkeshead, Ambleside, Ulverston, Rosthwaite, Grasmere, Patterdale, and Borrowdale; the Langdale Pikes; the Duddon Valley, celebrated in Wordsworth's series of sonnets; Honister Pass, and Kirkstone Pass; the Castle Rock of St John, celebrated in Scott's *Bride of Tricrain*; and such minor but imposing mountain-peaks as Bleneathara or Saddleback (2847 feet), near Keswick; Coniston Old Man (2633), near Coniston; and the Great Gable (2950), near Wastdale Head.

But far more even than its romantic natural beauty is the rare interest that has been added to this district by the group of illustrious poets who made it their home about the beginning of the 19th century, and who were somewhat unintelligently grouped together by unsympathetic critics as forming the 'Lake School' of poetry. Of these the most illustrious was Wordsworth, who has interpreted for us with marvellous fidelity and force the life—animate and inanimate alike—of the country which he knew and loved. His *Excursion* is the best of all guide-books to the Lakes—*Wordsworthshire*, as Lowell aptly terms the district; and students of English poetry will never lose an interest in those hallowed scenes in which the modern High-priest of Nature first expounded the co-operative spiritual harmony between man and nature herself, and taught how the mute life in nature ever leads upwards to the conscious life in man and the creative force in God. He was born at Cockermouth; he had his education at Hawkeshead school; he lived thirteen years in three houses at Grasmere, and thirty-seven at Rydal Mount; and he lies fittingly, with his wife, his children, and his gifted sister Dorothy, in Grasmere churchyard, in the midst of the scenery he has made enchanted. His first house at Grasmere, Dove Cottage or Town End, his home from December 1799 to May 1808, and of De Quincey for more than twenty years thereafter, was bought in 1890 by public subscription for permanent pro-

tection as a memorial of Wordsworth. His lifelong friend and brother poet, Southey, lived for forty years at Greta Hall, near Keswick, and rests in Crosthwaite churchyard hard by. Here also at Greta Hall Coleridge lived awhile, often visiting the Wordsworths; and here his children were brought up by Southey. The hapless Hartley Coleridge lived long at Nab Cottage, near Rydal Water, and is buried beside Wordsworth in Grasmere. Christopher North lived at Elleray, near Windermere; Shelley lived some time at Keswick after his marriage, and Mrs Hemans at Dove Nest on Windermere. Harriet Martineau had her home at the Knoll, near Ambleside; and not far off is Fox How, where Dr Arnold found rest from the strain of Rugby, and where he died. James Spedding was born at Bassenthwaite, and here was visited by Edward Fitzgerald and Tennyson; and the latter lived some time at Tent House on the east bank of Coniston Lake. At Brantwood, near Coniston Lake, Ruskin resided during the later years of his life. The poet Gray spent a fortnight of 1769 in traversing the Lake District, and his *Journal* shows that he looked before his time at nature with 'distinctness and unaffected simplicity,' in Wordsworth's phrase. Hither came in the summer of 1802 Charles Lamb, with his sister Mary, to spend three weeks with Coleridge at Keswick. He appears to have thoroughly enjoyed the new experiences, yet in a letter

to his friend Manning (24th September 1802) he writes with a spirit worthy of Dr Johnson: 'After all, Fleet Street and the Strand are better places to live in for good and all than amidst Skiddaw.'

Wordsworth himself wrote a *Description of the Scenery of the Lakes in the North of England* (1822), in which it is interesting to see how the descriptions glow with recollections of love, and how hot is his indignation against all wanton attempts to artificialise the face of nature. He would have denounced the Manchester scheme for bringing water from Thirlmere, and actively supported the aims of the 'Lake District Defence Society' (established in 1883).

See Professor Knight's *English Lake District, as interpreted in the Poems of Wordsworth* (1878), and his *Through the Wordsworth Country*, with 56 engravings by Harry Goodwin (1887); also Harriet Martineau's *English Lakes*, with illustrations by W. J. Linton (1858), T. G. Bonney's *English Lake Scenery* (1876), and Edwin Waugh's *Rambles in the Lake Country* (1861) and *In the Lake Country* (1880). Of the innumerable guides may be mentioned those of W. Hutchinson (1776), T. West (1789), J. Hudson (1843), Miss Martineau (1855), James Payn (1859 and 1867), H. I. Jenkinson's *Practical Guide* and his *Tourist Guide* (1879), Raddeley's *Thorough Guide* (1880), and G. R. Mill, *The English Lakes* (1896).

Lake-dwellings (Ger. *Pfahlbauten*, 'pile-dwellings'), habitations placed on platforms supported by piles, or other substructures, in the shallows around the margins of lakes, have only recently become known to archaeologists, although the first notice of a lake-dwelling community was written by Herodotus in the 4th century B.C. He describes certain tribes on Lake Prasias in Macedonia as living in huts on platforms supported on piles which were approached from the land by a single narrow bridge. It now appears that from the very earliest times down to the commencement of the historic period there were lake-dwellings of various descriptions in the lakes of central Europe, and that a similar custom continued in Scotland and Ireland to much later times. Owing to an extraordinary subsidence of the waters of the Swiss lakes in 1854 the remains of a lake-dwelling were discovered at Meilen in the lake of Zurich, and it was speedily found that similar

remains of pile-dwellings, each indicating the site of a relic-bed in the mud of the lake-bottom, existed in proximity to the shores of most of the lakes in Switzerland. Since their first discovery the sites of these ancient settlements have been thoroughly explored and systematically described by Dr Keller, F. Troyon, and others. The relics of this singular phase of early civilisation, which have been carefully gathered into the museums of Switzerland, disclose the condition of the industrial arts among the lake-dwellers, as manifested in the successive stages of the stone, bronze, and iron periods of their culture and civilisation. There is nothing known of the origin of the lake-dwelling phase of social life. It has been suggested that a desire for greater security from attack than could be afforded by a cluster of dwellings situated on the mainland first led to the selection of natural islets as the sites of habitations, and when this had become an established custom the transition was easy from the selection of natural islands to the construction of artificial islands where natural sites for habitations isolated by water did not exist. As a matter of fact there are several varieties of artificial lake-

dwellings of which the sequence is not certainly known. The substructure is usually all that remains. It has been found in some instances to be a mass of stones, and in others a mass of brush-wood, built up from the bottom of the lake. The more common form in Switzerland, however, is a substructure of piles, driven into the lake-bottom, and the heads brought level to support the platform for the huts. Where the water is deep and the bottom soft, the piles are driven only for a short distance, and stones accumulated around and among them to keep them in position. In some cases the lower ends of the piles have been mortised into a kind of horizontal framework of logs, to give greater stability to the superstructure. The piles are usually tree-trunks with the bark on, and the platforms were frequently the same, though sometimes the trunks were split or roughly boarded. On this platform the huts were erected. Nothing usually remains of them, but in some instances the remains of the lower tiers of boarding have been detected. In all cases in which the form of the huts could be determined it has been rectangular. But it seems deducible from the curvature of some

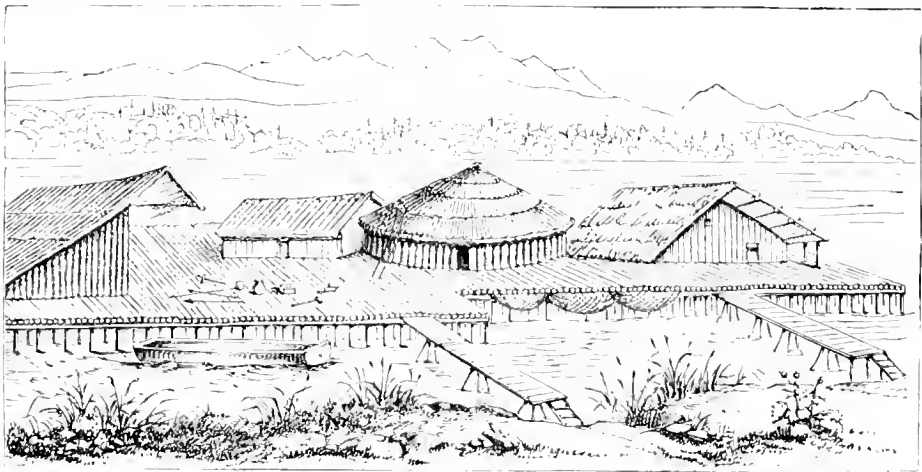

Fig. 1.—Lake-dwelling restored.

pieces of hardened clay, with the marks of interwoven branches upon them, that circular huts of wattles and daub were also constructed. They were doubtless thatched with straw and reeds. There were many huts on one platform, and a narrow gangway was generally carried on piles from the platform to the shore. Sometimes a dug-out canoe seems to have been used instead of a gangway, but as they seem often to have had horses, sheep, goats, and cattle on the platform, the gangway would be in such cases a necessary adjunct to a settlement, the piles of which have been occasionally found to indicate a superficial area of 100,000 square feet, and which was therefore practically a village on piles. The number of lake-dwellings discovered in the lakes of Switzerland exceeds one hundred and forty. The best known of these are Meilen in the lake of Zurich, Wangen in the lake of Constance, Robenhansen in the small and partially dried up lake of Pfaffikon, and Moosseedorf in the small lake of that name, all stations of the stone age; Moringen in the lake of Biemle, Estavayer in the lake of Neuchatel, and Morges in the lake of Geneva, all stations of the bronze age; and Marin, otherwise known as La Tene, in the north end of the lake of Neuchatel, a station of the iron age.

In the settlements of the stone age the cutting

implements, such as axes, knives, saws, are made only of stone. As flint is not abundant in Switzerland, the larger implements, such as axes, are generally made of diorite, serpentine, and other hard and tough stones, and sometimes even of nephrite and jadeite. The smaller implements, such as knives, saws, arrow-points, and spear-heads, are usually made of chipped flint, but the axes are cut out of the block by a sawing process, the cuts being made to some depth on opposite sides, and the parts separated by a blow. Those axes or axe-hammers that were perforated by a hole for the haft were bored by a drill of soft wood worked with sand. The stone axes were, however, for the most part mere wedges not perforated for the haft, but fixed in a socket in the end of a short piece of stag's horn, through which the perforation for the handle was made. Sometimes the handle itself was perforated, and one end of the stag's horn mounting, which carried the stone axe socketed into its other end, was mortised into the handle. Bitumen was used as a cement to fix the stone tools of all kinds in their handles of horn or wood. Arrow-points, notched or barbed, and harpoon-points for spearing fish were made of bone. The pottery of the stone age settlements was coarse but plentiful, and the cooking vessels were occasionally of large size. The lake-dwellers of the stone age were agriculturists,

cultivating on the adjacent mainland their crops of wheat, barley, millet, and flax, and rearing flocks and herds, the cattle being sometimes stalled upon the platforms. They were hunters and fishers, and their food seems in consequence to have been both varied and plentiful. Amongst the animals they hunted, and whose remains have been found in the relic-beds underneath the dwellings, are the urus and bison, the elk, the ibex, and chamois, the wild-boar and stag; and they kept the domestic ox, the horse, swine, sheep, goats, and dogs. They stored nuts and dried apples cut in halves; and among the charred remnants of their food fragments of their cakes of bread have been discovered. To the same charring action of the fire which seems in several cases to have consumed the huts we owe the preservation of many specimens of their textile fabrics, woven of well-spun flaxen threads, and of their fishing-nets, and mats made of bast or fibre of the lime-tree, and ropes and lines of plaited twigs, or cords of flaxen thread.

The pile-dwellings of the bronze age appear to have been placed farther from the shore than those of the stone age. The settlements of the bronze age also exhibit an increase in the number of domestic animals, and a corresponding decrease in the number of wild animals used for food. The pottery, though not thrown upon the wheel, is finer in form and much more highly ornamented, often with patterns of great elegance, painted in black or red, and sometimes inlaid with strips of tin. In settlements founded in the bronze age, such as that at Morges in the lake of Geneva, bronze is almost the only material used in the manufacture of their implements and weapons; and consequently stone and bone implements are as rare in them as bronze implements are in the earlier settlements. But there are a number of settlements which seem to have existed during the transition period, in the relic-beds of which the implements of stone and bronze are found mingled together. The forms of the bronze objects found in the lake-dwellings do not materially differ from those generally found diffused over central Europe. One feature of the lake-dwellings is the abundance and variety of the bronze ornaments, and the extraordinary development of the pins with ornamental heads, which are found of all sizes up to 15 inches in length. The bracelets are penannular, often hollow, or C-shaped in section, and decorated on the convex surface with a variety of sunk patterns composed of combinations of straight lines and circles. The principal varieties of the implements and weapons of bronze are axes, chisels, gouges, saws, sickles, knives, daggers, spear-heads, swords, hammers, and anvils. The knives are very abundant, and there is one large variety, with a curved and almost scythe-shaped blade, having a thick back, which is characteristic of the lake-dwellings. There is a smaller knife with an oval or crescent-shaped blade, so thin and sharp that it has been taken for a razor. The swords are mostly of the broad-bladed and slightly tapering form found in central Europe, and often have their handles also of bronze. Moulds of stone for casting the different varieties of bronze implements, weapons, and ornaments have been found in the relic-beds, showing that the articles were manufactured in the settlements in which they were used. In the principal settlement of the bronze age at Morges the number of bronze articles found exceeds 500.

The settlement of Marin in the lake of Neu-

châtel is the best known of the lake-dwellings of the iron age. As the area occupied by the piles is about 1200 feet long by 250 feet wide, the settlement was undoubtedly a large one. Several caldrons of thin bronze with iron ring handles attached to the rim were found here; and a number of small articles of bronze were also found, none of which were of bronze age types. The weapons were all of iron. They consist of short double-edged swords, the edges straight to within a short distance of the point, and large, broad, and thin-bladed spear-heads, sometimes oval or leaf-shaped, but usually with wavy or indented edges. Several of the sword-blades are damascened, after the ancient method of damascening by welding together strips of metal differently prepared, and some have makers' marks. The sheaths are of iron, beaten very thin, and are remarkable both for their elegance of form and the peculiar nature of their decoration. This has been sometimes supposed to be Etruscan, but it much more closely resembles the style of ornamentation which is now known in France as Gaulish, and is common to a series of

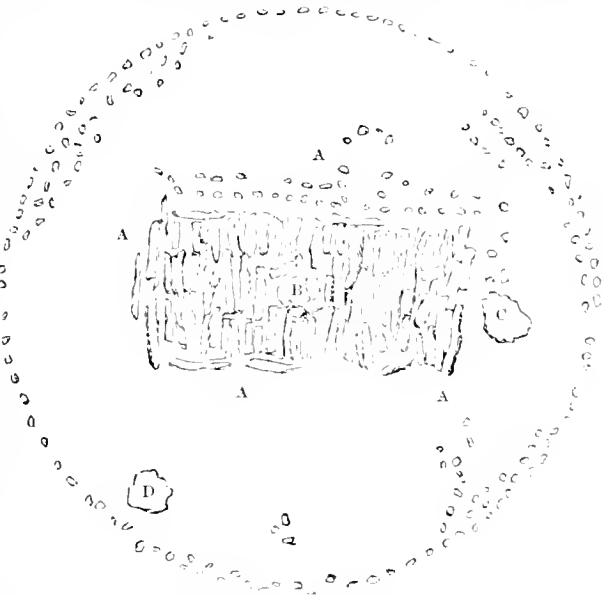

Fig 2.—Ground-plan of Crannog in Drumaleague Lough.

grave-mounds occurring both in France and Switzerland. The other articles found at Marin are shield-mountings, fibulae, buckles, bridle-bits, and hatchets, all of iron, a number of rings or bracelets, beads, &c. of coloured glass, playing dice and other small objects of bone, pieces of Roman pottery, and Roman and Gaulish coins. The latest of the coins is of the reign of the Roman Emperor Claudius, 41 to 54 A.D.

There is no means of computing the antiquity of the earlier lake-dwellings of Switzerland, but Dr Keller remarks on this point that, 'although the actual determination of the age of the lake-dwellings is doubtful, yet we may say with perfect certainty that they are more than 2000 years old, and with a considerable amount of probability that they reach back from 1000 to 2000 years before Christ.' Lake-dwellings have also been found on the Italian side of the Alps in the lake of Garda and the Lago Maggiore; in Savoy in the lakes of Bourget and Paladru; in Austria in the bed of a dried-up lake at Laibach, and in several small lakes near Salzburg, and in Bavaria and Pomerania. In Scotland and Ireland, where

they are numerous, they are known as Crannogs (q.v.), from the Celtic word *crann*, 'a tree.' The crannogs, however, are not constructed like the Swiss pile-villages. They are either palisaded refuges on small islets of natural formation, or artificial islets formed of brushwood, stones, and earth, and steadily and protected by piles driven through and around the mass. The problem presented to the crannog-builders was to construct, in a maximum depth of 10 or 12 feet of water, a solid, compact, and generally circular island, with a radius of 50 feet or thereby, capable of providing a permanent means of refuge and shelter for a considerable number of men and animals. The process is thus described by Dr Munro: 'Over the site chosen a circular raft of tree-trunks laid above branches and brushwood was formed, and above it additional layers of logs, together with stones, gravel, &c., were heaped up till the mass grounded. As this process went on, poles of oak were inserted here and there, the rough logs forming the horizontal layers were pinned together, and at various levels oak-beams mortised into one another were stretched across the substance of the island and joined to the surrounding piles. When a sufficient height above the water-line was attained, a prepared pavement of oak-beams was constructed, and mortised beams were laid over the tops of the encircling piles which bound them firmly together. The margin of the island was also slantingly shaped by an intricate arrangement of beams and stones, constituting a breakwater.' Frequently a wooden gangway stretched to the shore; in other cases the only means of access was by canoes, hollowed out of oak-tree trunks. Much the same system of construction appears to have been followed in Ireland. The plan (fig. 2, p. 487) of one of two crannogs in Drumaleague Lough, in the county of Leitrim, given on a scale of 1 inch to 20 feet, shows a circle of piles enclosing a space of 60 feet in diameter, with remains of supplementary circles at several points in the interior of the main or outer circle. In the centre is the log-pavement, A, about 35 feet by 25 feet, probably the floor of the log-house, which was the principal building on the crannog. In the centre of this pavement is a hearth-place, B, covered with flat stones, still showing traces of fire. On the outside of the pavement is another hearth-place, C, on a bed of stiff clay, while around a large tree root, D, the top of which has been dressed with a hatchet, and which may have served as a table, were found the refuse of the daily food in the shape of the broken and split bones of deer and swine. The crannogs are generally very much smaller than the Swiss lake-settlements, and from the nature of their construction there is no relic-bed. Those of Ayrshire and Galloway in Scotland have yielded objects dating from the time of the Roman occupation of Scotland to quite recent times. The most characteristic objects recovered from the Irish crannogs belong to the period of the Norse incursions, ranging from the 8th to the 10th and 11th centuries. There have been a few exceptional instances of the discovery of implements of stone and bronze age types in apparent association with the crannog structures, but so far as is yet known there is no crannog in Scotland or Ireland that can with any degree of certainty be assigned to the age of stone, or to the age of bronze. They seem to belong exclusively to the iron age and the historic period. There are frequent references to the use of crannogs as refuges and strongholds in the early Irish annals, and in Scottish and Irish historical documents of the 16th and 17th centuries. The first traces found in North America of anything resembling the lake-dwellings of Europe are at the mouth of Na man's Creek, a tributary of the Delaware.

The custom of living in wooden houses erected on piles over the waters of a lake, river, or inlet of the sea is still practised by barbarous tribes, and has been described by many travellers in the Malayan Archipelago, New Guinea, Venezuela, and in central Africa. When Ojeda, Vesputi, and the other discoverers entered the lake of Maracaibo in 1499, they found an Indian village constructed on piles above the water, and thence called it Venezuela ('little Venice'). The dwellings of the Papuans along the coasts and river-banks of New Guinea are built of bamboo and raised on stakes, and are grouped together. Cameron saw regular villages of pile-dwellings on Lake Mohrya in central Africa, each separate, and accessible only by jealously-guarded canoes.

See Munro, *The Lake-dwellings of Europe* (1890); Keller, *The Lake-dwellings of Switzerland* (trans. by Lee, 2d ed. 1878); Munro, *Ancient Scottish Lake-dwellings, or Crannogs* (1882); Wood-Martin, *The Lake-dwellings of Ireland* (1886).

Lake of the Thousand Islands, an expansion of the St Lawrence (q.v.) extending about 40 miles below Lake Ontario. It contains some 1500 rocky islets, the largest, Wolfe Island (48 sq. m.; pop. 2383), measuring 2½ miles by 7.

Lake of the Woods, a large lake of North America, studded with numerous wooded islands, mostly in Ontario, but touching also Manitoba and Minnesota. Gold was found about it in 1897. The lake is nearly 100 miles long, and about 300 in circuit. It is fed by the Rainy River, and drained by the Winnipeg.

Lakes (originally prepared from *lac*, whence the name) are pigments or colours formed by precipitating animal or vegetable colouring matters from their solutions chiefly with alumina or oxide of tin. Cochineal and madder lakes are the only ones used by artists. The former are prepared with Cochineal (q.v.) and alumina, and according to their shade of red, or purple red, are known as carmine, crimson lake, scarlet lake, purple lake, and Florentine lake. These were formerly much employed for landscape-work by water-colour painters, and are still in request for flower painting, but they have not much stability. The madder pigments of this kind, called rose madder or madder lake and madder carmine, are on the other hand quite permanent, both as water-colours and oil colours, and are much prized by artists. There are several yellow lakes made, but they are fugitive, and consequently but little used.

Paper-stainers and decorators use several pink lakes prepared by saturating a strong decoction of Brazil-wood and other dye-woods with chalk, starch, and a little alum. To these such names as Venetian, Florence, and Berlin lakes are applied. The two best lakes used by decorators are crimson and morone lakes.

Lakh. See *LAC*.

Lakshmi, in Hindu Mythology, the name of the consort of the god Vishnu (q.v.), and considered also to be his female or creative energy.

Lalande, JOSEPH JÉRÔME LE-FRANÇOIS DE, a French astronomer, was born at Bourg, 11th July 1732. Sent to Paris to qualify for an advocate, he was attracted to astronomy, which he studied under Delisle and Lemoigner. The latter persuaded the Academy of Paris to send Lalande to Berlin in 1751, to determine the moon's parallax, whilst Lacaille was sent to the Cape of Good Hope. On his return he was appointed one of the astronomers-royal, and in 1762 succeeded Lemoigner in the professorship of Astronomy in the College de France, a post which he held down to his death on 11th April 1807. He lectured with great success, and published several astronomical works of a

popular kind, as well as works of greater scientific value. In 1795 he was appointed Director of the Paris Observatory. His character was marked by extreme vanity; nevertheless he contributed greatly to the general progress of astronomical science. His principal work is *Traité d'Astronomie* (2 vols. 1764; 3d ed. 3 vols. 1792). In 1802 he instituted the Lalande prize for the most notable astronomical book or observation of the year.

Lalita-Vistara is the name of one of the most celebrated works of Buddhist literature. It belongs to the northern Buddhists, but is of unknown origin and antiquity, existing only in a debased Sanskrit version. It contains a narrative of the life and doctrine of the Buddha Sakya-muni, and is considered by the Buddhists as one of their nine chief works, treating of *Dharma*, or religious law.

Lally-Tollendal, THOMAS ARTHUR, COUNT DE LALLY and BARON DE TOLLENDAL, a French general, was born at Romans, in Dauphiné, in January 1702. His father, Sir Gerard Lally, was an Irish Jacobite refugee, and commander of an Irish regiment in the French service. Lally distinguished himself as a soldier in Flanders, especially at the battle of Fontenoy; accompanied Prince Charles Edward to Scotland in 1745; and in 1756 was appointed commander-in-chief in the French East Indian settlements. He commenced vigorous hostilities against the British, took many towns, and besieged Madras itself; but, having sustained a severe defeat, he was compelled to retreat to Pondicherry, which was attacked in March 1760 by land and sea by a greatly superior British force. Lally, however, held out for ten months; then, capitulating on 16th January 1761, he was conveyed as a prisoner of war to England. But, hearing that he had been accused of treachery and cowardice in India, he obtained leave to proceed to France for the vindication of his character. There he was thrown into the Bastille, and kept two years before his trial took place. The parliament of Paris at last condemned him to death for betraying the interests of the king and the Indian Company, and the sentence was executed on 9th May 1766. But his son, supported by the powerful assistance of Voltaire, procured a royal decree on 21st May 1778, declaring the condemnation unjust, and restoring all the forfeited honours. See Malleon's *French in India* (new ed. 1884), and Hamont's *Fin d'un Empire Français aux Indes* (1887).

That son, TROPHIMUS GERARD, MARQUIS DE LALLY-TOLLENDAL, born in Paris, 5th March 1751, was one of those nobles who in the States General of 1789 united with the Third Estate; but, alarmed at the democratic tendencies of the National Assembly, he afterwards allied himself with the court. He laboured to procure for France a constitution with two chambers and a privileged aristocracy; and earnestly sought to protect the king, but was himself obliged to flee to England. After the Revolution of 18th Brumaire, he returned to France. Louis XVIII. made him a peer. He died at Paris on 11th March 1830. He was the author of a famous *Defence of the French Emigrants* (1794); and a *Life of Wentworth, Earl of Strafford* (2d ed. 1814).

Lama. See LLAMA.

Lamaism (from the Tibetan *bla-ma*, 'spiritual teacher or lord') is the name of the religion prevailing in Tibet and Mongolia. It is Buddhism corrupted by Sivaism, and by Shamanism or spirit-worship. As ancient Buddhism knows of no worship of God, but merely of an adoration of saints, the latter is also the main feature of Lamaism. The essence of all that is sacred is comprised by this religion under the 'three most precious jewels'

—viz. the 'Buddha-jewel,' the 'doctrine-jewel,' and the 'priesthood-jewel.' The first person of this trinity is the Buddha; but he is not the creator, or the origin of the universe; as in Buddhism, he is merely the founder of the doctrine, the highest saint, though endowed with all the qualities of supreme wisdom, power, virtue, and beauty, which raise him beyond the pale of ordinary existence. The second jewel, or the doctrine, is the law or religion—that which is, as it were, the incarnation of the Buddha, his actual existence after he had disappeared in the Nirvāna. The third jewel, or the priesthood, is the congregation of the saints, comprising the whole clergy, the incarnate as well as the non-incarnate representatives of the various Buddhistic saints. The latter comprise the five Dhyāni-Buddhas, or the Buddhas of contemplation, and, besides, all those myriads of Bodhisattvas, Pratyeka-Buddhas, and pious men, who became canonised after their death. Inferior in rank to these saints are the gods and spirits, the former chiefly taken from the Pantheon of the Sivaïtes. The highest position amongst these is occupied by the four spirit-kings—*Indra*, the god of the firmament; *Yama*, the god of death and the infernal regions; *Yamādakka*, or Siva, as the avenger in his most formidable shape; and *Vaisravana*, or the god of wealth. The worship of these saints and gods consists chiefly in the reciting of prayers and sacred texts, and the intonation of hymns, accompanied by a kind of music which is a chaos of the most unharmonious and deafening sounds of horns, trumpets, and drums of various descriptions. During this worship, which takes place three times a day, the clergy, summoned by the tolling of a little bell, are seated in two or more rows, according to their rank; and on special holidays the temples and altars are decorated with symbolical figures, while offerings of tea, flour, milk, butter, and others of a similar nature, are made by the worshippers; animal sacrifices or offerings entailing injury to life being forbidden, as in the Buddhistic faith. Lamaism has three great annual festivals. According to Huc, there are rites corresponding to baptism and confirmation; and the principal religious ceremony closely resembles high mass. Lamaism does not allow the interment of the dead. Persons distinguished by rank, learning, or piety, are burned after their death; but the general mode of disposing of dead bodies in Tibet, as in Mongolia, is that of exposing them in the open air, to be devoured by birds and beasts of prey. The Lama must be present at the moment of death, in order to superintend the proper separation of body and soul, to calm the departed spirit, and to enable him to be reborn in a happy existence.

One of the most interesting features of Lamaism is the organisation of its hierarchy. Its summit is occupied by two Lama popes, the one called *Dalai-lama*, i.e. Ocean priest, or priest as wide as the ocean—the 'Grand Lama,' residing at Potala, near Lhasa—and the other bearing the titles of *Tesho-lama*, *Bogdo-lama*, or *Pan-chhen*. In theory, both popes have the same rank and authority, in spiritual as well as in temporal matters; but, as the Dalai-lama possesses a much larger territory than the other, he is in reality much more powerful. Next in rank are the *Khontakts*, who may be compared to the Roman Catholic cardinals and archbishops. The third degree is that of the *Khulbilghans* or *Hobilghans*. Their number is very great. These three degrees represent the clergy that claims to be the incarnation of the Buddhistic saints. The Dalai-lama and the Pan-chhen were in their former lives the two chief disciples of the great Lamaist reformer, M'tsong kha pa, who is reputed to have founded in the 14th century of

the Christian era the present system of the Lama hierarchy. The Khutukts were in their prior existences other Buddhistic saints of very great renown; and the Khubilghans are those reborn hosts of saintly patrons whom the temples and convents of Lamaism possess in boundless numbers.

In order to ascertain the re-incarnation of a departed Lama, various means are relied upon. Sometimes the deceased had, before his death, confidentially mentioned to his friends where and in which family he would reappear, or his will contained intimations to this effect. In most instances, however, the sacred books and the official astrologers are consulted on the subject; and if the Dalai-lama dies it is the duty of the Panchhen to interpret the traditions and oracles. It is understood that the imperial court at Peking has more to do with the selection than is admitted by the priests. Down to 1880 there had been no fewer than 103 Dalai lamas.

Besides these three classes of the higher clergy Lamaism possesses a lower clergy, which, having no claim to incarnate holiness, recruits its ranks on the principle of merit and theological proficiency. It has four orders: the pupil or novice, who enters the order generally in his seventh or ninth year; the assistant priest; the religious mendicant; and the teacher or abbot. All the members of these orders must make the vow of celibacy, and by far the greatest number of them live in convents, the number of monks, in proportion to the population, being enormous. A Lamaist convent consists of a temple, which forms its centre, and of a number of buildings connected with the temple, and appropriated to the meeting-rooms, the library, refectory, dwellings, and other spiritual and worldly wants of the monks. At the head of the convent is a Khubilghan, or an abbot, the latter being elected by the chapter and appointed by the Dalai-lama, or the provincial Khubilghan. In addition to these orders of monks and convents, Lamaism has likewise its nuns and nunneries. The Lamaist bible bears the name of *bKa'gyur* (or *Kandjur*), 'translation of the words,' namely of the Buddha. It contains not less than 1083 works, which in some editions fill 102 to 108 volumes in folio.

See BUDDHISM, LHASA, TIBET; Koppen, *Die Lamaische Hierarchie* (1859); Hue, *Souvenirs* (1852); Ritter's *Erskunde* (1881); Rhys-Davids, *Buddhism* (1880); E. F. Knight, *White Throne Empires Met* (1893); L. Austin Waddell, *The Buddhism of Tibet, or Lamaism* (1895); A. B. Savage Lander, *In the Forbidden Land* (1898).

La Mancha. See MANCHA.

Lamantin. See MANATEE.

Lamarck. JEAN BAPTISTE PIERRE ANTOINE DE MONNET, CHEVALIER DE, evolutionist, born at Bazentin in Picardy, 1st August 1744, was educated for the church at the Jesuit College of Amiens, which he left at the age of seventeen to join the French army then warring in Germany. Having gained rapid promotion to officer's rank, he was sent in 1763 to the garrisons at Toulon and Monaco, where he became impressed with the Mediterranean flora. Accidental injuries led him to resign his position, and brought him to Paris, where he was forced to work in a banker's office, while his spare energies were devoted to the study of plants. In 1773, thanks in part to Buffon, he published a *Flore Française*, in which he applied a new analytical method of classification. As tutor to Buffon's son, he had the opportunity of visiting Holland, Germany, and Hungary. In 1774 he became a member of the French Academy and Garde de l'Herbier du Jardin du Roi—the nucleus of the famous post-revolutionary *Jardin des Plantes*. In one of the twelve chairs associated with this 'Jardin' Lamarck remained for twenty-five years as professor of what we would now call Invertebrate

Zoology. In 1801 or earlier he had begun to think actively about the relations and origin of species, expressing his conclusions in 1809 in his famous *Philosophie Zoologique*. Of his other great work, *Histoire des Animaux sans Vertèbres*, he published seven volumes between 1815 and 1822. Hard work and illness enfeebled his sight and left him for the last ten years of his life not only blind but poor. To one of his two daughters he dictated the last volume of his Invertebrate Zoology, while to keep himself alive he was forced to part with some of his treasured collections. Greater than his contemporaries and immediate successors dreamed, Lamarck died in comparative obscurity, 18th December 1829, aged eighty-five.

Apart from his contributions to classification and descriptive zoology, Lamarck had a twofold importance, as an expositor of the now accepted theory of descent, and as an inquirer into the still debated factors in evolution. It is easy to find in his *Philosophie Zoologique* passages which foreshadow many modern suggestions in regard to evolution, including the theory of natural selection; but the gist of his thinking is fairly expressed in the following propositions: (1) Every considerable and sustained change in the conditions of life produces a real change in the needs of the animals involved; (2) change of needs involves new habits; (3) altered function evokes change of structure, for parts formerly less used become with increased exercise more highly developed, other organs in default of use deteriorate and finally disappear, while new parts gradually arise in the organism by its own efforts from within (*efforts de son sentiment intérieur*); (4) gains or losses due to use or disuse are transmitted from parents to offspring.

There can be no doubt that Lamarck, though beyond doubt an independent thinker, was influenced by Buffon, and also perhaps by Erasmus Darwin, whose *Loves of the Plants* had been translated into French in 1799. On his contemporaries he exercised little influence—in fact it was not till the Darwinian revival of etiology that the worth of Lamarck began to be justly appreciated. To those who deny the transmissibility of all characters individually acquired in direct response to changed functions and surroundings, the theory of evolution according to Lamarck seems to be based on an undemonstrated if not erroneous hypothesis; to those, on the other hand, who believe that individually acquired characters are transmissible from parents to offspring, Lamarck's theory is part of the solution of the evolutionist's puzzle. Thus, while the majority of naturalists in Britain and Germany side with Darwin and Weismann against Lamarck, there is in France a distinctly Lamarckian school, and a *Banquet* of his admirers has been instituted; while in America what are called 'Neo-Lamarckian' views are vigorously upheld by many naturalists of eminence, such as Cope, Hyatt, and Packard, who seek to explain evolution according to fundamental 'laws of growth,' plus the inherited effects of use and disuse and of environmental influence.

See BUFFON, DARWIN, DARWINIAN THEORY, EVOLUTION, HEREDITY, &c. S. Butler, *Evolution, Old and New* (Lond. 1879); J. V. Carus, *Geschichte der Zoologie* (1872); C. Claus, *Lamarck als Begründer der Descendenztheorie* (1888); E. D. Cope, *The Origin of the Fittest* (Lond. and New York, 1887); Cuvier, 'Éloge de M. de Lamarck,' *Acad. des Sciences* (1832); M. Duval, 'Le Transformiste Français Lamarck,' an admirable sketch of his life and work, *Bull. Soc. Anthropol.* tome xii. (Paris, 1889); E. Haeckel, *Die Naturanschauung von Darwin, Goethe, und Lamarck* (1882), and translation of his *Natürliche Schöpfungsgeschichte*; Lamarck, *Histoire des Animaux sans Vertèbres* (1815-22), re-edition by Deshayes and Milne-Edwards (1835-45); *Philosophie Zoologique* (1809), re-edition with valuable biographical introduction

by Ch. Martins (1873); *Lamarek, par un Groupe de Transformistes, ses Disciples* (1887); A. S. Packard, Introduction to *Standard Natural History* (1885); and E. Perrier, *La Philosophie Zoologique avant Darwin* (1884).

La Marmora. ALFONSO FERRERO, MARQUIS DE, Italian general and statesman, born at Turin, 17th November 1804, who, entering the army, became known as a zealous reformer. He was decorated for distinguished conduct in the national war of 1848, and promoted to general of brigade. In 1849 he entered the cabinet as Minister of War. In 1855 he withdrew from the ministry to assume the command of the Sardinian troops in the Crimea, and at the close of the war was invested with the Order of the Bath and the Grand Cross of the Legion of Honour, and re-entered the ministry in his former capacity. He took part in the war of 1859, by which Lombardy was acquired by Italy; and was appointed commander-in-chief of the Italian army in 1861, and in 1864 prime-minister. In the campaign against Austria in 1866 he lost the battle of Custoza, and had to sustain unpleasant controversy as to his management of the campaign. Latterly he was entrusted with several diplomatic missions; he preferred the French to the Prussian alliance; and his publication (1873) of the secret negotiations between Prussia and Italy incurred the censure of Prince Bismarck. La Marmora died 5th January 1878. See a monograph by Massari (1880).

Lamartine. ALPHONSE MARIE LOUIS DE, French statesman and author, was born at Mâcon, 21st October 1790. He came of an ultra-royalist stock, and was educated in royalist principles. Up to 1815 a considerable portion of his time was spent in Italy, a country for which he had a deep affection. On the fall of Napoleon and the establishment of the Bourbons, Lamartine proceeded to Paris and entered the ranks of the Garde Royale. He soon returned to Italy, however, which he traversed on foot; and here, as his *Elvire* and *Julie* testify, he experienced a passion that kindled into energy those poetic gifts which ultimately made him one of the great singers of France. His first *Meditations* were published in 1820, and at this period he was appointed First Secretary of Legation at Naples. He subsequently became *charge d'affaires* at Florence, where he remained for five years, acquiring a wide knowledge of international politics. Lamartine married an English wife, Marianne Birch, who shared in her husband's labours and aspirations. In 1829 Lamartine, foreseeing impending difficulties, declined the post of Secretary of State for Foreign Affairs in the Polignac ministry. He accepted a mission to the new king of Greece, Leopold of Belgium (elected 11th February 1830; resigned 15th May). At the same time he published his *Harmonies Poétiques et Religieuses*, which excited such enthusiasm that he was unanimously elected to the Academy. Lamartine, still a royalist in principle, disapproved of the revolution of July 1830. His friends nominated him at Dunkerque and Toulon for election to the Chamber of Deputies, but he was defeated at both places, and went on a tour to the East. He wrote an account of his travels, entitled *Souvenirs d'Orient*. Recalled to France in 1833, he was returned for both Mâcon and Bergues, and elected to sit for the latter place. But Mâcon being his native place, his fellow-townsmen would not be denied, and re-elected him almost unanimously in 1837. Between 1834 and 1848 Lamartine wrote and published his *Journaux*, *La Chute d'un Ange*, and the celebrated work, the *Histoire des Girondins*, which the Conservatives erroneously alleged was the cause of the revolution of 1848. The historian merely saw further into the future than most of his con-

temporaries. The Orleanist régime was repugnant to him because of its duplicity, and when the monarchy fell he accepted the inevitable. It was he who insisted upon an appeal to the people. He was a member of the Provisional Government which formally proclaimed the Republic at the Hôtel de Ville. The new order having been established on the basis of liberty, equality, and fraternity, the ministry was constituted with Lamartine as Minister of Foreign Affairs. Lamartine, who was the presiding genius of the government, endeavoured to rule the country according to the principles of constitutional liberty, but there was an extreme party, headed by Louis Blanc and Ledru Rollin, which sought to establish national workshops and to effect social changes of a sweeping character. A formidable outbreak on the 15th of May, resulting from the refusal of the Assembly to appoint a Minister of Labour, and which eventually led to the expulsion of Louis Blanc, was suppressed by the vigorous efforts of Lamartine. In June, however, a more serious rising occurred, upon which the executive committee resigned their functions, and conferred the command of the forces on General Cavaignac. After a terrible conflict the insurrection was suppressed, Lamartine had already stepped down from power, and from the time when Louis Napoleon acquired the ascendancy through unscrupulous means his political career practically closed. He now devoted himself to literature, publishing in the order named the two series of the *Confidences*, his *Raphael*, *Geneviève*, the *Tailleur de Pierres de St-Point*, and that valuable contribution to the study of continental politics, the *Histoire de la Restauration*. He likewise edited several *Collections* of his former writings, *Discours divers*, and issued monthly his *Entretiens Familiaux*. Lamartine continued to take an interest in public affairs, discussing them eloquently with his friends, but his patriotic spirit revolted against the iron rule of Napoleon III. In consequence of his straitened circumstances, parliament voted Lamartine a moderate pension, and the Paris town-council presented him with a chalet in the Bois de Boulogne. He died on February 28, 1869. See the Life by Lady M. Dumville (1888), and by Deschanel (2 vols. Par. 1893).

Lamb. CHARLES, essayist, critic, and humorist, was born on the 10th of February 1775, in Crown Office Row, in the Temple, London, where his father was clerk and confidential servant to Samuel Salt, a wealthy bencher of the Inner Temple. For this, as for many other details of Lamb's private and domestic life, we are indebted to his essays, which form the best of all commentaries on his biography. (His father, John Lamb, is the Lovel of the essay on the 'Old Benchers of the Inner Temple.') There were seven children born to John Lamb and his wife in the Temple, of whom three only survived their early childhood—Charles Lamb, his sister Mary, ten years older than himself, and a yet older brother, John. Charles received his first schooling at a humble academy, out of Fetter Lane, but at seven years of age he obtained, through Samuel Salt, a presentation to Christ's Hospital, where he remained for the next seven years. His school experiences, and the friendships he formed, notably that with Samuel Taylor Coleridge, three years his senior, are again familiar to all readers of the *Essays of Elia*. At the age of fourteen he left school with a fair amount of scholarship, and an intensified love of reading. He might have stayed and become a *Grecian*—as the highest class boys were denominated—and so proceeded to the university. But the exhibitions were given on the understanding that the holder was to take holy orders, and Lamb's unmountable stammer barred him from that profession.

Lamb left Christ's Hospital in November 1789.

At that time his brother John held a post in the South Sea House, of which Samuel Salt was a deputy-governor, and Charles was soon presented through the kind offices of this friend to a humble situation in the same company; but early in 1792 he obtained promotion in the shape of a clerkship in the accountant's office of the India House, where he remained for more than thirty years. In this same year Samuel Salt died. The occupation of his old clerk and servant was at an end; and with his legacies from his employer, Charles's salary, and whatever Mary Lamb could earn by needle-work, in which she was proficient, the family of four (for John Lamb was living a comfortable bachelor life elsewhere) retired to humble lodgings. In 1796 we find them in Little Queen Street, Holborn, and it was there that the terrible disaster occurred, destined to mould the career and character of Charles Lamb for the whole of his future life. There was a strain of insanity in the children inherited from the mother. The father, who had married late in life, was growing old and childish; the mother was an invalid, and the stress and anxiety of the many duties devolving on Mary Lamb began to tell upon her reason. In an attack of mania, induced by a slight altercation with a little apprentice girl at work in the room, Mary Lamb snatched up a knife from the dinner-table, and stabbed her mother, who had interposed in the girl's behalf. Charles was himself present, and wrested the knife from his sister's hand. It was a critical moment in the young man's history. The father was all but imbecile; the mother was no more; and the whole direction of affairs for the sister's future remained with Charles. The inquest resulted in a verdict of temporary insanity. Mary would in the natural course have been transferred for life to a public asylum; but, by the intervention of friends, the brother's guardianship was accepted by the authorities as an alternative. To carry out this trust Charles Lamb from that moment devoted his life, sacrificing to it all other ties and ambitions, and never flagging in duty and tenderness for thirty-eight years. It was inevitable that the family should leave the scene of this 'day of horrors;' the old father with his son Charles removed to Pentonville, where at successive lodgings they remained until the father's death. The house in Little Queen Street no longer stands. With two or three other houses adjoining, it has been pulled down, and a church now stands upon its site—a not unfitting memorial of the spot where Lamb consecrated his future life by an act of devotion as remarkable as any recorded in the annals of literature. Mary Lamb remained subject to attacks of temporary aberration for the rest of her life. The attacks were usually foreseen, and at such seasons she was removed to some suitable asylum. The length and frequency of these periods of absence increased, until the closing years of her brother's life, when she was exiled from him during the greater part of each year. In the meantime Charles Lamb had fallen in love, but renounced all hope of marriage when the duty of tending his otherwise homeless sister had appeared to him paramount. The history of his brief attachment, to which there is frequent pathetic allusion in his writings, is obscure. The girl, who appears in his earliest sonnets as Anna, and in his essays as Alice W., was in fact named Anne Simmons, and resided with her mother in the village of Wilford, in Hertfordshire—the scene of Lamb's early romance of *Rosalind Gray*. Lamb's grandmother, Mrs. Field, was house-keeper at Blakesware, a dower-house of the Plumer family, closely adjoining Wilford; and during Lamb's frequent visits to Blakesware (immortalised in one of the loveliest

of his essays as 'Blakesmoor, in Hertfordshire') he had made the girl's acquaintance. She afterwards married a Mr. Bartum, a London silversmith, and is referred to under that name in the essay *Dream Children*.

Lamb's earliest poems, written in 1795, were prompted by this deep attachment. Two sonnets on this theme, with two others on different topics, were included in S. T. Coleridge's earliest volume of poems, issued at Bristol in 1796. In the following year a second edition of Coleridge's poems appeared, 'to which are now added poems by Charles Lamb and Charles Lloyd.' The latter was a young man of kindred poetic tastes, whose acquaintance Lamb had made through Coleridge. Here, as before, the poetic influence under which Lamb wrote was the same that had so strangely moved Coleridge, while still at Christ's Hospital—the graceful and melancholy sonnets of W. L. Bowles. In the following year Lamb and Lloyd made a second venture in a slight volume of their own (*Blank Verse*, by Charles Lloyd and Charles Lamb, 1798); and here for the first time Lamb's individuality made itself felt in the touching and now famous verses on the 'Old Familiar Faces'—like so many of his memorable utterances in prose and verse, full of autobiographical allusion, and yet gaining rather than losing in permanence of charm through the circumstance. It was, however, in prose, not in verse, that he was to find his true strength.

In the same year as the *Blank Verse* just mentioned he published his little prose romance, *The Tale of Rosalind Gray and Old Blind Margaret*; and four years later his *John Woodvil*—the fruit of that study of the dramatic poetry of the Elizabethan period, in the revived study of which he was to bear so large a part. Lamb had little or no dramatic faculty. The little play was crude and valueless as a drama, but with detached passages reflecting much of the music and quaintness of Fletcher and Jonson. Meantime, Lamb and his sister were wandering from lodging to lodging, too often forced to leave through the rumour of Mary Lamb's malady which followed them wherever they went. They had lived at more than one house in Pentonville—they were in Southampton Buildings in 1800 and 1801—and then removed to Lamb's old familiar neighbourhood, where they continued for sixteen years. The early years of their residence in the Temple were among the hardest and saddest of their lives. They were very poor; Charles's experiments in literature had as yet brought him neither money nor reputation; and the gradual accession of new friends that might have brightened their path had the drawback of bringing Charles face to face with social temptations which he could not resist. A very moderate indulgence in wine or spirits seems to have speedily affected him, and his shyness and his impediment of speech made him eagerly resort to what for the moment made him forget both. 'We are very poor,' writes Mary Lamb in 1804; and again in 1805, 'It has been sad and heavy times with us lately.' In Lamb's anxiety to raise a few pounds, rather than from any confidence in his dramatic faculty, he began to write a farce, which the proprietors of Drury Lane accepted, and produced in December 1806. It was the now famous farce *Mr H.*—famous, however, not for its success, but for its failure. His love for things dramatic soon found a more profitable outlet in a commission from William Godwin to contribute to his 'Juvenile Library,' then in course of publication. For this series Charles and Mary wrote in 1807 their well-known *Tales from Shakespeare*—Mary Lamb making the version of the comedies, Charles that of the tragedies. This was Lamb's

first success. It brought him sixty guineas, and what was more valuable, hope for the future, and the increased confidence and recognition of his growing circle of friends. As one consequence of the success, the brother and sister composed jointly two other children's books—*Mrs Leicester's School* (1807) and the *Poetry for Children* (1809). Charles also made, single-handed, a prose version of the *Adventures of Ulysses*. Another more important consequence was a commission from the Longmans to edit a volume of selections from the Elizabethan dramatists. The volume at once exhibited Lamb, to those who had eyes to see, as one of the most profound, subtle, and original of English poetical critics. Three years later a conviction of the same fact would be deepened in those who knew that the unsigned articles in Leigh Hunt's *Reflector*, on Hogarth and the tragedies of Shakespeare, were from the same hand, and that a prose writer of new and unique quality was showing above the dull level of the conventional essayist.

In 1817 Lamb and his sister left the Temple for rooms in Great Russell Street, Covent Garden. Next year an enterprising young publisher induced him to collect his scattered verse and prose in two neat volumes, as the *Works of Charles Lamb*, and this publication naturally paved the way for his being invited to join the staff of the *London Magazine*, then newly started. Lamb was required to contribute light prose essays, and was wisely allowed a free hand. His first essay appeared in August 1820, 'Recollections of the old South Sea House,' the public office in which his first small salary was earned, and where his elder brother had remained a high-placed and prosperous clerk. Lamb signed his first paper *Elia*, borrowing for a joke the name of a foreigner who had been fellow-clerk with him in the office. The signature was continued through Lamb's successive contributions to the magazine; and as he placed it on the title-page (without his own) of the first collected edition of the essays in 1823, it became indissolubly connected with the work. The series came to an end, as far as the *London Magazine* was concerned, in 1825. *The Last Essays of Elia* were collected in a second volume in 1833.

In August 1823 Charles and Mary quitted their rooms over the brazier's in Russell Street, and made their first experiment as householders in a cottage in Colebrooke Row, Islington, with the New River (into which George Dyer walked in broad daylight) flowing within a few feet of their front door. Moreover, they were now on the eye of making a pleasant addition to their household in the form of a young friend, the orphan daughter of an Italian teacher of languages at Cambridge. Charles and Mary Lamb virtually adopted Emma Isola, and she was treated as a member of their family until her marriage with Edward Moxon the publisher, in 1833.

Early in 1825 Lamb, who had been for some time failing in health, was allowed to resign his post in the India House, the directors liberally granting him as pension two-thirds of his then salary. Having now no tie to any particular neighbourhood, the brother and sister were free to wander. They took lodgings—and subsequently a house—at Enfield; but Mary Lamb's health becoming gradually worse and necessitating constant supervision, they parted with their furniture and gave up house-keeping. They finally removed to the neighbouring village of Edmonton, where in a small cottage, hard by the church, they spent the last year of their joint lives. It was a melancholy year. Lamb's own health was suffering. They had lost their young friend Emma Isola. The absence of settled occupation had not brought Lamb all the comfort he had looked for: the

separation from his London friends, and the now almost continuous mental alienation of his sister, left him companionless, and with the death of Coleridge in the summer of 1834 the chief attractions of his life were gone. In December of the same year, while taking one day his usual walk on the London Road, he stumbled and fell, slightly injuring his face. The wound was in itself trifling, but erysipelas ensued, under which he rapidly sank, and he passed quietly away, without pain, on the 29th of December. He was buried in Edmonton churchyard. His sister survived him nearly thirteen years, and was buried by his side in May 1847.

Lamb's place in literature is unique and unchallengeable. As a personality he is more intimately known to us than any other figure in literature, unless it be Samuel Johnson. He is familiar to us through his works, which throughout are composed in the form of personal confidences; through his many friends who have loved to make known his every mood and trait; and through his letters, the most fascinating body of correspondence in our language. It is a dangerous thing to say, but it may be doubted whether, outside a necessarily limited circle, his works are read so much for their own sakes as for the light they throw upon the character of their author. It is the harmonious concord of dissonances in Lamb that is the secret of his attraction. The profound and imaginative character of his criticism, which at its best is unerring, and with it the reckless humour of the Bohemian and the *farceur*; the presence of one lamentable weakness serving to throw into stronger relief the patient strength of his life's struggle; his loyalty and generosity to his friends, even when they abused it most; and all this flowing from one of the most beautiful acts of devotion in the records of self-sacrifice; the wild fun of Trimenlo and Stephano, alternating with the tenderness of Miranda and Ferdinand, or the profound philosophic musings of Prospero—and all these, like Ariel, now 'flaming distinctly,' now 'meeting and joining'—it is this wondrous blending of opposites that has made Lamb, save to the 'sour-complexioned' and matter of fact, one of the most dearly loved among English men of letters, and with every sign that this love is one which no changes of taste are likely to diminish.

Our chief authorities for Lamb are his own writings, and the *Life and Letters*, and *Final Memorials*, by the late Mr Justice Talbot. Later editions of these works have appeared, enlarged by Percy Fitzgerald and W. C. Hazlitt. There is a quite separate memoir of Lamb, of considerable interest, by the late B. W. Prater ('Barry Cornwall'). Another memoir, and a complete edition of Lamb's works and correspondence, by the writer of the present article, are published by Messrs Macmillan. E. V. Lucas's *Lamb and the Lloyd's* (1898) should also be cited as an interesting work.

Lamb, WILLIAM. See MELBOURNE.

Lamballe, MARIE THÉRÈSE LOUISE OF SAVOY-CARIGNAN, PRINCESS DE, was born at Turin, 8th September 1749, the daughter of the prince of Carignan. Beautiful and charming, she was made by Marie Antoinette superintendent of the royal household, and her own intimate friend and companion. Princess Lamballe proved her devotion to her royal mistress by returning to France (whence she had escaped to England) after the unsuccessful flight from Versailles, by sharing the queen's imprisonment for a week in the Temple, and finally by refusing to take the oath expressing detestation of the king, queen, and monarchy (3d September 1792). As she stepped out of the courtroom on that fatal day she was cut to the ground; her body was given up to the fury of the populace, who paraded her head and heart on pikes in front

of the queen's windows. See *Lives by Lescaur* (1865), *Bertin* (2d ed. 1894), and *Sir F. Montefiore* (1896).

Lambayeque, a province of Peru, with a pop. of 86,000, is mostly a rainless, barren region, with some fertile valleys. The capital, Lambayeque, situated 7 miles from the mouth of the river Lambayeque, lies 128 miles NW. of Trujillo, and has manufactures of woollen and cotton fabrics. Pop. 6300.

Lambert, DANIEL. See OBESITY.

Lambert, JOHANN HEINRICH, a philosopher and mathematician, was born 29th August 1728, at Mülhausen in Upper Alsace. He was successively clerk, secretary, and private tutor, studied assiduously all the time, and at last lived the life of a private gentleman. In 1764 Frederick the Great made him a member both of the Council of Architecture and of the Academy of Sciences. He died at Berlin, 25th September 1777. Lambert was the first to lay a scientific basis for the measurement of the intensity of light, in his *Photometria* (1760); and he was especially skilful in applying the analytical methods of mathematics. A work on analytical logic from his pen, *Neues Organon* (2 vols. 1764), was greatly valued by Kant, with whom Lambert kept up a correspondence. Of his other works we may mention *Kosmologische Briefe* (1761) and *Anlage zur Architectonik* (1771). See *Huber's Life of him* (1829) and *Lepsius's monograph on his philosophy* (1881).

Lambert, JOHN, one of the chief soldiers in the great Civil War, was born in the parish of Kirkby Mallum, in Yorkshire, September 7, 1619, studied at the Inns of Court, but on the outbreak of the war became a captain under Fairfax, and thereafter showed such conspicuous capacity and courage that he rose rapidly in rank. At Marston Moor he led Fairfax's cavalry on the right wing, was commissary-general of the army in the north after the formation of the 'new model' (1645), major-general of the northern counties (1647), helped Cromwell to crush Hamilton at Preston, captured Pontefract Castle in March 1649, after a three months' siege, and was thus absent from London during the trial of the king. In 1650 he went with Cromwell to Scotland as major-general, led the van at Dunbar, next traversed Fife and defeated the opposing army at Inverkeithing, followed Charles through the western shires to Worcester, and on the day of Cromwell's 'crowning mercy' commanded the troops on the eastern bank of the Severn. He took a prominent part in the installation of Oliver as protector, but actively opposed the proposition to declare him king. He was unable to take the oath of allegiance to the Protector, and became completely estranged from him. After his death he became the head of the cabal of discontented officers which overthrew the feeble administration of Richard Cromwell. Lambert was now looked upon as the leader of the Fifth Monarchy or extreme republican party; suppressed with considerable vigour the royalist insurrection in Cheshire, August 1659; and two months afterwards, dismissing the remnant of the Rump Parliament, virtually governed the country along with his officers under the title of the 'Committee of Safety.' Monk frustrated his designs; he was sent to the Tower, tried in 1662, and banished to Guernsey, where he died in 1683.

Lambessa, or LAMBESE, an Algerian town of 1700 inhabitants, 65 miles SSW. of Constantine, stands amidst the imposing ruins of the ancient *Lambesis*, capital of Numidia.

Lambeth, a metropolitan parliamentary borough in Surrey, forms part of the south-west quarter of London, and since 1885 returns four members. The old borough of Lambeth, which

had a much larger area, returned but two members. Lambeth Bridge dates from 1862. Lambeth Palace has been the official residence of the archbishops of Canterbury since 1197. It contains a splendid series of portraits of the archbishops, and a valuable library of 30,000 volumes, with many fine MSS. The Lollards' Tower, so named in comparatively modern times from the notion that heretics were here imprisoned, was really a water tower. It dates from 1431, but has been restored and modernised. See the Rev. J. Cave-Browne's *Lambeth Palace* (1883). For Lambeth Degrees, see DEGREES. The Lambeth Articles, drawn up in 1595 by Archbishop Whitgift and others, were nine in number, and pronouncedly Calvinistic in doctrine. They were disapproved by Queen Elizabeth, and were never in force. See also DOULTON.

Lamb's Lettuce. See CORN SALAD.

Lamb's-wool, an old English beverage, composed of ale and the pulp of roasted apples, with sugar and spices.

Lamellibranchiata. See BIVALVES.

Lamelliferous, a very numerous family of beetles, for illustration of which see COCKCHAFFER, DUNG-BEETLE, &c.

Lameness is commonly due to some abnormal condition either of the joints or of the muscles and fasciæ of the lower limbs: mere difference in length between the two limbs, even to the extent of an inch or more, is not necessarily incompatible with a natural gait. It is generally one of the earliest symptoms of disease in the joints; and permanent stiffness of any of these, whether the result of disease or of injury, always involves some degree of lameness. The weakness and imperfect development of the muscles which usually follows infantile paralysis is one of the commonest muscular causes. Severe wounds or rupture of any of the important muscles must also be mentioned. Unnaturally shaped or ill-fitting boots, with the corns, bunions, distortion of toes, and other ill effects they produce, are a fertile source of lameness; but conditions thus produced are generally in some degree amenable to treatment. Among the causes most apt to be overlooked are the slighter degrees of flat-foot, of contraction of the calf muscles, or other muscles whose tendons are inserted into the bones of the foot, and of the plantar fasciæ. See also the articles LEGS, ARTIFICIAL LIMBS, CLUB-FOOT, &c.

Lamennais, FELICITÉ ROBERT DE, was born at St Malo, 16th June 1782, the fourth of the six children of a merchant and shipowner, who was ennobled in 1788 by request of the States of Brittany for his patriotic services and for supplying cheapened corn to the poor during a time of scarcity, but who was too modest to use his title or the privileges it bore. His mother was a saintly woman of remarkable ability and of Irish descent, who died when he was but five years old. He grew up slender and small in stature, nervous and weak in health, but lively and restless in temperament, and from a very early age he took to books, and read widely at his will in his uncle's library. He loved music, and became expert in swimming, riding, and fencing, and it is said fought a duel with credit in 1802 or 1803. But the dominant passion of his youth was solitary study, and his earliest companions were doubt and melancholy. It is a fact not without significance that his first communion was deferred till he was twenty-two, at the time when his eldest brother Jean was ordained a priest. The pair retired about the end of 1805 to the solitude of their joint estate of La Chesnaie, two leagues from Dinan, and there, amidst almost savage surroundings, but in an ample library, the real education of Lamennais

began. In 1807 he translated the *Guide Spirituel* of Louis de Blois: Napoleon's police suppressed his *Reflexions sur l'Etat de l'Eglise* (1808). He received the tonsure in March 1809, and his letters of that period reveal a vein of lofty and somewhat mystical devotion and an inward joy of which he was to taste but little in later years. But study, prayer, and meditation could not satisfy all the cravings of his nature, and this exaltation of mind soon gave place to the malady of genius, that vague unrest and distaste for the present which was the fundamental undertone in the constitution of Lamennais. The years from 1806 till 1814 he spent in a narrow range of studies, shut out from the world, the vultures of vague unrest tearing at his heart, while he remained forging the weapons of controversy. He taught mathematics in his brother's seminary, shared his quarrel with the new university, and wrote together with him the ultramontane and anti-Gallican *Tradition de l'Eglise sur l'Institution des Evêques* (1814). In 1815, during the Hundred Days, he took refuge in London, where he was befriended and much influenced by the Abbé Carron. In November he returned to Paris, and with sore misgivings both before and after he was ordained priest at Vannes. At Paris in March 1816 he wrote the first volume of his famous *Essai sur l'Indifférence en matière de Religion* (1818-24), a magnificent, if paradoxical, denunciation of the right of private judgment and the doctrine of toleration—itsself but a virtual unbelief, 'a new kind of persecution against the church.' The whole is a polemic against the individual reason on which certitude cannot rest; its conclusion that the unity of society depends ultimately on the unity of truth, and that all systems but the Catholic destroy one another and lead to scepticism. Three different systems of indifference are in turn examined and refuted: (1) that of those who, repudiating religion for themselves, believe that it is necessary for the people—atheism, and the organised religious polity of the empire; (2) that of those who believe religion to be necessary for men, but that God has not given any special revelation of how He would be worshipped—natural religion, and 18th-century deism; (3) that of those who believe in a divine revelation through a book, but hold that God has left men to interpret it for themselves—Protestantism. In the *Defense de l'Essai* he answered opponents of the most opposite camps, advocates of freedom in thought, Gallican monarchists who refused to admit that the source of all authority was the holy see, and Ultramontanians themselves, who took fright at a bold attempt to find support for the Christian revelation in an analysis of human tradition.

In 1824 Lamennais received a flattering reception at Rome, and it is said that Leo XII. was anxious to give the new Bossuet a cardinal's hat. But soon after this other dreams than those of a pure theocracy enthroned in the Vatican began to fill his mind, and already notions of popular liberty appear in the *Progrès de la Révolution* (1829). The revolution of July (1830) quickened his pulse, and in the famous journal *L'Avenir*, founded in September, with his young friends Lacordaire, Montalembert, and the Abbé Gerbet, ideas strange to Ultramontanians were eagerly advocated. But the old chimæra refused to be rejuvenised, the Jesuits and bishops took fright at the new doctrines of liberty of the press, of instruction, and of discussion, and the journal was suspended by spiritual authority in 1831. Lamennais, Lacordaire, and Montalembert set out for Rome to lay bare their hearts to the Holy Father. The disastrous story is told in *Les Affaires de Rome* (1836), one of the most interesting of all the writings of Lamennais. His Holiness Gregory XVI. gave the ardent tribune

but a quarter of an hour's audience, talked to him of art, pointed out the claw in a lion of Michael Angelo's, and, according to the Abbé Riard, offered him a pinch of snuff. After waiting in vain for an opportunity of conference, they returned doubtful and disheartened at the cowardly chicanery and worldliness of Rome. A severe condemnation reached them at Munich, 30th August 1832, the date of the beginning of the second life of Lamennais. He signed obedience, but the iron had entered his soul. He retired to La Chesnaie, and there watched with sinking heart a more shameful betrayal still of his Master by the Vicegerent of Christ in the final extinction of Polish nationality, crushed to death by Russia with the sympathy of Austria and before the approving eyes of Rome. Here, in one week of restless walking under the oaks, he pointed out the prophetic inspirations of his whole heart in the *Paroles d'un Croquant* (1834), a glowing poem rather than a treatise, expressed in rhythmical prose arranged in short verses like those of the Bible, under forms now parabolic, now direct, at one moment recalling the gloom of the *Inferno*, at another the tenderness of the *Imitation*. The apocalyptic empyrean is a region far above the rules of logic, and it is impossible to set forth precisely the doctrine of this strange book further than to describe it as an illusion of a perfect society, ideal, Paradiseic, governed by love, hindered awhile by the wickedness of despots, but ultimately to be effectuated by perfect liberty. The book made an extraordinary sensation; Sainte-Beuve tells us how he found the composers gathered round while one of their number read the MS. aloud, his voice trembling with emotion. To churchmen it was 'the apocalypse of Satan,' 'the *bonnet rouge* planted upon a cross.' It brought about the complete rupture of the apostle with his old associates; repulsed by the pope, he had made his appeal to the people against Rome, itself become faithless to its mission, and henceforth he belonged to the people alone. His further books, *Le Livre du Peuple*, *Une Voix de Prison*, *Du Passé et de l'Avenir du Peuple*, were but weaker echoes of his masterpiece. For one he got a year's imprisonment in Sainte Pelagie. In the revolution of 1848 he started paper after paper, and poured forth a succession of pamphlets while struggling on bravely against broken friendships, ill-health, and poverty. His piety survived the shipwreck of his faith; he had the gift of attaching friends who still loved the man whatever his opinions, and to these he poured forth his thoughts in impetuous swiftness as he paced up and down, his limbs trembling with emotion. George Sand describes his austere and majestic face, the brow an unbroken wall, furrowed between the eyebrows with those perpendicular wrinkles which, Lavater says, belong exclusively to those of high capacity who think justly and nobly—its rigid austerity ever lightened and humanised by the sudden smile of tenderness. To the last he remained a Breton even to his accent. His ideas and emotions alike ever tended towards excess and to absoluteness of conviction; his temperament was framed for suffering, and his passionate devotion to truth, the foundations of which yet slipped from under him, made his intellectual life a very martyrdom. Lamennais sat in the Constituent Assembly till the *coup d'état* ended his dreams of popular liberty. At his death, which occurred February 27, 1854, he refused to make his peace with the church, and was buried, by his own desire, without religious rites, in an unmarked grave among the poor at Pere-la-Chaise.

In his *Correspondance*, edited by M. Émile Fergues (2 vols. 1858; 3d vol., ed. by his son, M. Eugène Fergues, 1886), we see the ebb and flow of his stormy emotions for twenty years. His brother and sister kept back from

publication many of his papers, but five posthumous volumes appeared under the care of Forgnés (1855-58), of which at least one volume, that entitled *Mélanges philosophiques et littéraires*, was quite worthy of his name. M. Blaize, the nephew of Laennec, edited his *Œuvres complètes* (2 vols. 1866), mainly composed of additional letters. Amid the storms of his later life he found consolation in writing his serene and large-minded *Esquisses d'une Philosophie* (4 vols. 1840-46), perhaps the most really remarkable of all his works.

See Blaize's *Essai Biographique* (1858); Sainte-Beuve, in *Portraits Contemporains*, vol. i., and *Nouveaux Laudes*, vols. i. and xi.; Guizot, in vol. iii. of his *Mémoires*; E. Scherer, in vol. iv. of his *Études sur la Littérature Contemporaine*; Renan, in *Essais de Morale et de Critique* (1859); E. Dowden, in *Studies in Literature, 1789-1877* (1878); and Paul Janet, *La Philosophie de Linnæus* (1890).

Lamentations. BOOK OF, a canonical book of the Old Testament which, in the present arrangement of the Hebrew Bible, occupies the sixth place among the Hagiographa (between Ruth and Ecclesiastes), and bears the superscription *'Echa* ('Ah, how'; see chap. i. 1; ii. 1; iv. 1). In the Talmud and elsewhere it is called the book of *Kenoth* ('elegies' or 'dirges'), a name which reappears in the Septuagint title *Thrēnoi* (Lat. *Lamentationes* or *Lamentata*). The fuller title, *Lamentations of Jeremiah*, is found in the Syriac and in some MSS. of the Septuagint, but is not so old as the shorter form. The book consists of five dirges or laments, the first four of which are alphabetical acrostics (like Ps. cxix.); each of the five consists of twenty-two verses, except the third, which has sixty-six. In general character the first four are very similar, each beginning with a representation of the great calamity that has befallen the city and people, and then rising through the thought of Jehovah's righteousness to the hope of his just vengeance on the enemies of his people. The fifth differs from the others in that it takes the form of a prayer and is throughout pervaded by a sense of Jehovah's wrath, which is spoken of as having been long continued. The tradition, which attributes the authorship of Lamentations to Jeremiah, can be traced to a note prefixed to the Septuagint translation, where, as in the Syriac, they are now attached to the book of that prophet. Perhaps, indeed, this tradition is already implied in 2 Chron. xxxv. 25, in which case the supposed reference to Josiah must be sought in Lam. iv. 20. The internal evidence is rather against the attribution of the Book of Lamentations to the prophet. Nagelsbach, following Ewald, has shown how completely different is its style from that of Jeremiah; some of the indications that were at one time supposed to make for his authorship disappear on closer examination; and the anticipated restoration of Israel is somewhat dissimilar in the two works.

See Ewald's *Dichter des Alten Bundes*, vol. i. (2d ed. 1866), and the commentaries of Nagelsbach (1868; Eng. trans. 1871), Keil (1872; Eng. trans. 1874), and Payne Smith (in *Speaker's Commentary*).

Lametric. JULIEN OFFRAY DE, French philosopher, born at St Malo on Christmas-day 1709, studied first for the church, but subsequently went over to medicine, and was trained by Boerhaave at Leyden. He entered the French army as surgeon in 1742; but the publication in 1745 of a thorough-going materialistic work, *L'Histoire Naturelle de l'Âme, traduite de l'Anglais de Sharp* (a fictitious name), roused such a feeling of odium against him that he was compelled to seek refuge in Leyden (1746). The work was of course Lametric's own. But in Leyden the fear of persecution still dogged his footsteps: he published *L'Homme Machine* (1748), and was glad to escape a threatened arrest by accepting an invitation

from Frederick the Great of Prussia to settle in Berlin. In Germany Lametric continued his materialistic studies in *L'Homme Plante* (1748), *L'Art de Jouir* (1751), *La Volupté*, and other works. A good deal of the enmity excited against him was occasioned by cynical and satirical books which he published against the medical men, including such great authorities as Boerhaave, Linnæus, Astruc, Winslow, &c. Lametric died at Berlin on 11th November 1751. Frederick himself wrote a memoir, which he caused to be prefixed to the philosophical works of Lametric (2 vols. 1774). The best account of Lametric is in Lange's *History of Materialism* (1878-81). See also the study by Quépat (Paris, 1873), and that by Du Bois-Reymond (Berlin, 1875).

Lamia. DEMONOLOGY.

Laminaria. See SEAWEEDS.

Lamination. THE ARRANGEMENT of rocks in thin layers or laminae, the condition of a large proportion of the earth's strata. Shale deposits exhibit this structure very plainly, being frequently easily separable into the thin laminae in which they were originally deposited. Shale is the fine sediment that settles down at the bottom of some tranquil or slightly-moving water. The laminae indicate interruption in the supply of the materials, which may have been occasioned by successive tides, by frequent or periodical floods, or by the carrying medium having access to a supply of different material, passing, e.g., from mud to sand, and back again to mud. The laminae of the brick-clay deposits are separated, in many places, by the finest sprinkling of sand, which is almost invisible in the vertical sections. The layers are occasionally obvious, from their being of different shades of colour, often produced by the bleaching of the layers when they were deposited; but frequently the various laminae of a bed are so united, and the bed so homogeneous, that except when the face is exposed to weathering, the laminated structure is not visible. This condition seems to have resulted from the shortness of the interruptions in the deposit not permitting the solidification of any of the layers until all was deposited, when the whole set cohered together as a single bed.

Lammass-day. THE 1st of August, is one of the cross-quarter-days, or half-quarter days, in England. On this day, which is the feast of St Peter ad Vincula, it was customary in early times to make offerings of the first-fruits of the harvest, and hence the feast took the name of *Iluf-masse* (lit. 'loaf-mass'), afterwards corrupted into Lammass. In Scotland it was an ancient practice with farmers to pay the half-year's rent due at Whitsunday on Lammass-day.

Lämmergeier (*Gypactus barbatus*), a large bird of prey, also called the Bearded Vulture or Bearded Griffin. The full-grown bird is of a shining brownish-black colour on the upper parts, with a white stripe along the shaft of each feather; the head is whitish, with black stripes at the eyes; the neck and under-part of the body are rusty yellow. It is the largest bird of prey in the Old World, measuring almost 4 feet high when sitting, nearly 5 feet in length, and from 9 to 10 feet in expanse of wing. Though by no means brave, it is bold and rapacious, swooping down on hares, lambs, young goats, chamois, &c., and sometimes, it is said, on infants. But as the feet and claws are comparatively weak, only young and light animals are lifted, and it is very difficult to believe the circumstantial tales of their carrying children. The usual food consists of animals newly killed, but carrion and even offal are not despised. Once common in the Alps, it is now very rare, but occurs not infrequently in Sardinia, the Pyrenees, North Africa,

mountains, and the Himalayas, where it often soars high above the loftiest peaks. The lammergeier



Lammergeier (*Gypaëtus barbatus*).

is said by some to be the original of the fabulous 'roc.'

Lammermoors, a broad range of moorish hills in Haddington and Berwick shires, extending east-north-eastward from the vale of Gala Water to the German Ocean at St Abb's Head, and culminating in Lammer Law (1733 feet).

Lamorièrièrè, CHRISTOPHE LEON LOUIS JUCHAULT DE, a French general, was born at Nantes, 6th February 1806, entered the army as an engineer in 1826, and saw active service in Algeria, taking part in nearly all the military events which occurred in that country between 1833 and 1847. It was through his energy chiefly that the war against Abd-el-Kader was brought to a successful end by the capture of that chief in 1847. In June 1848 Lamorièrièrè commanded the attack on the barricades in Paris, and quelled the anarchic tumults of the Socialists. He was war-minister during the government of Cavaignac; but was arrested on the occasion of the *coup d'état* of 2d December 1851, and banished from France. When the Italian war of independence threatened the safety of the pope, Lamorièrièrè proceeded to Rome in 1860, and was appointed by Pius IX. commander of the papal troops. He was, however, defeated at Castellidardo by the Sardinian general, Cialdini, on 18th September, and on the 29th capitulated at Ancona. He died near Amiens on 10th September 1865. See Lives by Keller (2 vols. Paris, 1873; new ed. 1891) and Rastoul (1894).

La Motte Fouqué. See FOUQUÉ.

Lampblack is the soot or amorphous carbon obtained by burning bodies rich in that element, such as resin, petroleum, and tar, or some of the cheap oily products obtained from it. The supply of air is limited or controlled so as to produce a smoky flame, and the smoke passes into a chamber with some arrangement for receiving the abundant deposit of soot. For some of the finer qualities of lampblack this soot or carbon is purified by heating it in closed vessels. A large quantity of lampblack has been made in the United States by the imperfect combustion of natural gas. Lampblack is a useful pigment for artists both in oil and water colour, a coarser kind being employed by house-painters. It is the chief ingredient in Indian Ink

(q.v.), and along with boiled linseed oil forms printing-ink. Of it is formed the pigment for the carbon paper used in the Autotype Process (q.v.). Lampblack is also employed in the preparation of some kinds of leather, and for other purposes.

Lampedusa, a small island of the Mediterranean, 150 miles S. of Sicily, and 80 E. of Tunis. Belonging physically to the African continent, it has since 1863 been administratively reckoned part of the Sicilian commune of Licata. It has 19 miles of coast, and a small harbour. Fruits are grown, and some grain. Pop. 1074.

Lampeter, a market-town of Cardiganshire, 27 miles by rail NNE. of Carmarthen. It is the seat of St David's Theological College (1827), which has the power to grant B.A. and B.D. degrees. Pop. 1443.

Lamprey (*Petromyzon*), a genus of round-mouths (Cyclostomata, q.v.), nearly allied to the Hag (q.v.), and like it differing markedly from true fishes in the absence of jaws, paired fins, and scales, and in the presence of peculiar gill-pouches. An eel-like form, a slimy skin, a gristly skeleton, a primitive brain imperfectly roofed in, a single median nostril, a suctorial mouth with numerous horny teeth on the lips and on the large piston-like tongue, seven pairs of gill-pouches (whence the German name *neun-augig*, 'nine-eyes') opening by as many apertures to the exterior, and connected internally with a tube lying beneath and communicating with the adult gullet and the striking differences between young and mature forms are among the less technical characteristics. They differ from hag in the development of a dorsal fin, in the fact that the nasal passage ends blindly without opening into the pharynx, and in several peculiarities of the respiratory and other systems. Along with *Petromyzon*, there are several genera—e.g. *Mordacia* and *Geotria* from the coasts of Chili and Australia—differing only in detail. Lampreys occur both in the rivers and seas of the north and south temperate regions, and at least some of the marine forms spawn and pass part of their long larval life far up rivers. They seem to represent an ancient race, more primitive than fishes, and, though their gristly skeletons are unknown as fossils, certain structures called 'conodonts' from very early strata are identified by some as lamprey teeth.

The habits of lampreys are in many ways curious. Thus, though they will eat worms, larvae, small crustaceans, and dead animals, they have also learned the audaciously aggressive habit of fixing themselves to fishes, and scraping holes in the skin. The mouth sticks like a vacuum sucker, the toothed tongue works like a piston, and both flesh and blood are thus obtained by a sort of parasitism which reminds one at once of leech and hagfish. When engaged in sucking they are carried about by their victims, and salmon have been captured in the middle course of the Rhine with the marine lamprey attached to them (Günther). As the name *Petromyzon* suggests, they also attach themselves, as if to rest, to stones in the bed of the stream, or it may be even to the bottom of boats. Some species are able to move stones of considerable size to form nests, and their grip is so firm that it is occasionally difficult to detach them from their hold. When the mouth is occupied in its suctorial work, water passes in as well as out by the respiratory apertures. The spawning occurs in spring, usually far up rivers, and according to some the mature forms die after reproduction. From the small eggs young develop which live wallowing in the sand or mud of the streams, and feed on minute animals. They are so different from the parents that in the case of the small lamprey (*P. branchiatus*) they were for long

referred to a distinct genus *Ammocetes*. The head is small, the upper lip semi-circular, the lower lip small and separate, the mouth toothless and not suctorial, the eyes rudimentary and hidden, the future gullet (as distinguished from the above-mentioned respiratory tube) not yet developed, and so on. There is in fact a metamorphosis in the history of the lamprey, as was discovered 200

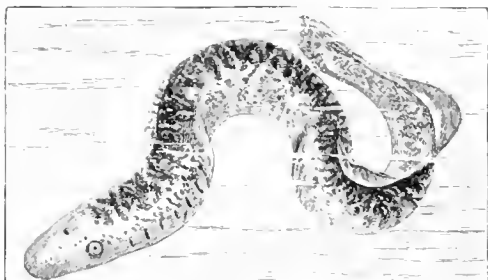

Lamprey (*Petromyzon marinus*).

years ago by a Strasburg fisherman Baldner, but overlooked till August Muller worked out the curious story in 1856. In the small river lampern—and analogous facts are probably true for the others—the change to the adult form is frequently postponed until the August of the fourth or fifth year, when it completes itself rapidly.

There are three British species—the sea-lamprey (*P. marinus*), over 3 feet in length, mottled greenish brown; the river lampern (*P. fluviatilis*), nearly 2 feet, dark bluish with silvery sides; the sandpiper, pride, stone-grig, or small lampern (*P. branchialis* or *planeri*), hardly one foot in length, like the preceding species in colour. The marine and river lampreys, though despised in Scotland, have been esteemed as good eating since Roman times, being especially palatable in pies and potted preserves. They are caught in baited baskets or traps, and their eel-like tenacity of life makes them useful bait stores.

Lamps are contrivances in which to utilise the illuminating power of fluid light-giving material. The most primitive lamps were probably skulls of animals, or certain kinds of sea-shells. The principle of these natural lamps was long retained in the ancient earthenware and metal lamps of Egypt, Greece, and Rome, and in the stone cups and boxes of northern nations. Such lamps were called *Lycbna* by the Greeks, and *Lucerna* by the Romans. Specimens obtained from the excavations of the ruins of Tarsus, Pompeii, and Herculaneum, and from other sources, show that they were made in considerable variety. A very primitive form of lamp, called a 'crucis,' was in use in Scotland until mineral oils were introduced by James Young about 1850. Animal fats and fish oils were the principal substances used in all parts of the world for burning in lamps till vegetable oils were introduced, viz. colza or rape, and other seed oils and nut oils of various kinds. The vegetable oils, being more limpid in character, admitted of improved and more complex means of burning them. Progress in this direction began in France with Leger, who in 1783 adopted flat ribbon wicks in place of the old round, thick, and smoky wick. He was followed in 1784 by Aimé Argand (q.v.), who introduced round cylindrical burners; and round burners, whether for oil or gas, are still known by his name as Argand burners.

In the use of fatty oils, the ordinary capillary attraction of the wick was insufficient to maintain a uniform flow of oil to the flame, and various con-

trivances were used to keep the oil as nearly as possible at one level. In 1803 M. Carcel introduced an excellent mechanical method of forcing the oil up by means of clockwork. This lamp, however, was too easily disarranged, and too expensive to come into general use. It was not till 1836 that Franchot invented his lamp, known as the 'French Moderator.' The main features of this lamp are a cylinder or oil-container with a tubular piston resting on the surface of the oil. This piston, being acted upon by a spiral spring placed between it and the top of the cylinder, forces the oil up through the piston and so maintains a constant supply of oil to the flame. The spring was wound up by rack and pinion. The unequal tension of such a spring, and the correspondingly unequal flow of oil, was counteracted (or 'moderated'—hence the name of the lamp) by placing a tapering iron rod in the ascending tube. This lamp was simple and effective, and soon supplanted all other mechanical arrangements for controlling the flow of oil to the burner; and it is the lamp still used by the few people who burn colza or rape oil in preference to mineral oils.

Mineral oils are known under various names, such as paraffin, petroleum, kerosene, crystal oils, &c., for the lighter sorts; and for the heavier or specially high list kinds such names as mineral sperm or mineral colza are used. These oils, being much more limpid and volatile than the fatty oils, rise freely in lamps by the ordinary suction of the wicks, and, being rich in carbon, a plentiful supply of oxygen is absolutely necessary to perfect combustion. The main problem, therefore, to be solved in the construction of a good paraffin or petroleum lamp was to secure a current of air powerful enough to consume the carbon contained in the oil, and so prevent its passing off in the form of smoke.

Previous to the introduction of mineral oils, camphine, which is a volatile hydrocarbon spirit distilled from turpentine, was burned in Young's 'Vesta' lamp, introduced in 1834. His lamp was constructed on the round or Argand principle, with a button or deflector over the central air tube, and a constricted chimney. The leading features of this lamp have been followed in many of the later developments of mineral oil lamps with circular wicks. But the common flat wick paraffin lamps now so familiar to every one were first made by Stobwasser in Berlin, and introduced into Great Britain in 1854. Since then the manufacture of paraffin lamps has grown to be an industry of great importance, and is carried on largely in England, Germany, and the United States. The number of patents in all these countries for paraffin or kerosene lamps has been enormous, but most of them refer simply to slight modifications of existing types. We cannot do more here than mention some of the chief improvements effected.

Mineral oil lamps are made with flat wicks and with circular wicks. The circular or Argand form of lamp has been generally adopted in continental countries. The body of the lamp or oil container is made of glassware or metal, mounted on a pedestal. The outward casing of the burner is made of brass perforated for the admission of air. In the centre of the burner the wick-tube or holder is inserted. Over the wick tube in flat wick burners a metal dome is placed to deflect the air into the flame. Across the dome there is a slit or oblong opening for the flame to pass through, and a chimney 8 or 10 inches high, resting on a gallery at the base of the dome, creates the current of air necessary to perfect combustion of the oil.

Flat-wick burners have the advantage of being more easily trimmed and the flame more easily controlled than round burners. They admit also

of a better supply of oxygen to all parts of the flame than has been possible with ordinary round burners, and are in consequence less liable to smoke. The most successful lamp developments in Great Britain have therefore hitherto been in flat-wick burners. In 1865 Messrs Hinks of Birmingham introduced the Duplex lamp, with two parallel wicks and two openings in the dome, producing two flames. This form of lamp rapidly became very popular, and still deservedly continues so. In 1874 Captain Doty patented his Triplex lamp, with three flat wicks arranged in the form of a triangle, open at each corner, so that an abundance of air circulates freely all round each of the three wick-tubes. There are three openings in the dome, and three flames which distribute the light nearly equally in all directions; and this no other flat-wick burner does. This is a powerful burner; it has little tendency to smoke, and is easily managed.

The great difficulty with round-wick burners has been to procure a sufficient supply of oxygen to the inside circumference of the flame, so that they are very liable to smoke after burning for a short time. To obviate this very serious objection a round burner was introduced, with a circular air-channel passing up from the base of the lamp through the reservoir and through the burner, which supplied a cool current of air to the inner side of the circular flame. This lamp of necessity was made of metal, and, having a metal tube passing from the burner down through the oil-container, was thus liable to raise unduly the temperature of the oil, and was considered too unsafe for general use. In 1885, however, Messrs Defries introduced an improved lamp of this type, with a thin metal casing enclosing the portion of the wick inside the oil reservoir, and open only at the bottom, so that no oil or oil vapour can escape from the lamp except by passing up through the wick from the bottom of the reservoir. By this means the Defries lamp becomes a perfectly safe lamp for domestic use. But it is still not free from the drawback which attaches to all circular burners—viz. the difficulty in ordinary domestic use of trimming the wick quite level all round.

A still later advance in lamps for burning mineral oils economically is a lamp patented by Messrs Ross & Atkins, which applies to oil illumination the regenerative inverted Argand principle so successfully employed by Siemens in gas-lighting. The mechanical difficulties of producing an inverted shadowless flame with oil are obviously very much greater than with gas; but these difficulties have been successfully overcome in this lamp, now introduced to the public by the Wanzer Company, under the name of the Down-flame Shadowless Lamp. The essential features are an annular reservoir, with three converging flat wicks, which unite to form a circular flame; a glass cup underneath the flame; and a compound chimney above. The flame curves inwards, and the products of combustion passing up through the centre of the burner heat the fresh air on its passage through the burner to the flame. It is doubtless this feature which gives to this lamp its greater economy in the consumption of oil, considering the intensity of light produced.

Mineral oils are now extensively used for heating and cooking, and the burners employed for these purposes are generally adaptations of the flat wick type. Captain Doty in 1868 patented a lighthouse lamp for burning mineral oils, and this method of lighting has since been adopted by all the important lighthouse services of the world, with much advantage to the mariner, and great economy as compared with the use of rape or colza oil (see LIGHT-HOUSE). These lamps consist of one or more

concentric wicks, and are capable of producing a very powerful light; one by Sir James Douglass, engineer to the corporation of the Trinity House, has eight concentric wicks, and produces a flame whose intensity is equal to 1400 candles.

COMPARATIVE TABLE.

Type of Lamp.	Candle power.	Consumption of oil per hour, in grains.	Consumption of oil per hour per candle power, in grains.
1-in. flat-wick burner.....	134	650	48
Duplex " " ".....	25	1250	50
Triplex " " ".....	39	1750	45
Defries' circular burner, 11-in. diameter.....	49	2290	47
Wanzer down-flame burner, 2½-in. diameter.....	90	3050	34

To burn mineral oils successfully both theory and experience teach the absolute necessity of keeping all parts of the burner perfectly clean, so that the ingress of air to the flame may not be lessened or impeded by deposits of carbonised wick, which accumulate unless removed from time to time when lamps are in use, and which moreover become a source of danger from their liability to ignite. Long experience has also shown that a most fruitful source of annoyance in burning these oils arises from the presence of water or moisture in the oil or in the lamp. The greatest care should therefore be taken to keep the oil and the lamps perfectly free from water, and new wicks should be carefully dried before being inserted in the burner. See also SAFETY-LAMP, LUCIFER.

Lamp-shell (*Terbratulida*), a genus of brachiopods, or a popular name for the whole class. See BRACHIOPODS.

Lampyris. See GLOW-WORM.

Lanark, the county town of Lanarkshire, on a slope near the right bank of the Clyde (q.v.), 33 miles by rail SW. of Edinburgh, and 31 SE. of Glasgow. It has an interesting ruined church, a large Catholic chapel (1859), the county buildings (1836), a good racecourse, memories of Wallace, and some weaving and other industries. A royal burgh since the 12th century, it unites with Falkirk, &c. to return a member to parliament. Pop. (1851) 5008; (1891) 4579.—NEW LANARK, 1½ mile S. by W., is a manufacturing village, founded in 1783 by David Dale, and for twenty-eight years the scene of the social experiments of his son-in-law, Robert Owen. Pop. (1831) 1901; (1891) 672.

Lanarkshire, or CLYDESDALE, a Scottish county, enclosed by Stirling, Dumbarton, Linlithgow, Edinburgh, Peebles, Dumfries, Ayr, and Renfrew shires. Its length is 50 miles, its greatest breadth 32 miles, and its area 889 sq. m. Drained almost entirely by the Clyde (q.v.) and its numerous affluents, Lanarkshire is subdivided into three wards, of which the upper or southern comprises 332,338 acres, the middle 194,211, and the lower 42,319. These offer a striking diversity of aspect—lonely uplands, smiling orchards, busy coalfields and manufacturing district. The principal hills are Green Lowther (2402 feet) and far seen Tinto (2335); whilst the mining village of Leadhills (1300 feet) is the highest in Scotland. The predominant rocks are Silurian, old red sandstone, and carboniferous, and the county possesses great mineral wealth—coal, ironstone, fireclay, shale, and lead, with some silver and even gold. The coal alone in the Lanarkshire coalfield is estimated to exceed 2000 million tons. The soil is as various as the scenery; and barely one-half of the whole area is in cultivation, whilst in 1888 89 woods occupied 20,148 acres, orchards 591, and market gardens 1313. The orchards of Clydesdale were famous as early as the time of Bede, and yielded into the 19th century £8000 per annum; but now the ground is more profitably employed in producing straw-

berries, gooseberries, vegetables, &c. for the Glasgow market. The climate is moist, mild and genial in many of the lower districts, but often cold and boisterous on the uplands. Lanarkshire is not a great grain county; but much of it is excellently adapted for the rearing of stock and for dairy purposes. The sheep are Cheviots and black-faced, the cattle Ayrshires; and the celebrated Clydesdale cart-horses issue from a Flemish cross (about 1720). The mineral, textile, and other industries are very extensive, and are noticed under the towns—Glasgow, Rutherglen, Lanark, Hamilton, Airdrie, Coatbridge, Motherwell, Wishaw, &c. Besides pre-historic and Roman remains, Lanarkshire contains the castles of Bothwell, Douglas, and Craignethan (Scott's 'Tillicoultry'), the priories of Blantyre and Lesmahagow, and the battlefields of Langside, Drumclog, and Bothwell Brig. Among its worthies have been Joanna Baillie, Dr John Brown, Sir Colin Campbell, Thomas Campbell, Lord Dundonald, David Livingstone, and Sir John Moore. Though only the twelfth in size, Lanarkshire is far the most populous and wealthy of all the thirty-three Scottish counties. Valuation (1875) £1,714,183; (1890) £2,226,352. Pop. (1801) 147,692; (1841) 426,972; (1881) 904,412; (1891) 1,105,899—an increase due largely to the transference hither of the portions of Glasgow formerly in Renfrewshire.

See works by Hamilton of Wishaw (1831), Irving and Murray (1861-64), and others cited at GLASGOW, CLYDE, COATBRIDGE, BIGGAR, &c.

Lancashire is a county palatine of England, ranking sixth in point of area, first in population, and first in return of revenue from all sources. It forms the north-western division of England, stretching along the shore of the Irish Sea from the river Duddon and the mountains of Cumberland on the north to the river Mersey on the south. It is bounded on the E. by Yorkshire, on the W. by the Irish Sea, on the N. by Cumberland and Westmorland, and on the S. by Cheshire. The extreme length from N. to S. (including the hundred of Furness) is 75 miles, and the greatest breadth at the south end 43, and at the north end 10 miles. The circumference is 240 miles, and the area 1905 sq. m., or 1,219,221 statute acres. Pop. (1801) 673,486; (1821) 1,052,948; (1841) 1,667,054; (1861) 2,429,440; (1881) 3,454,441; (1891) 3,926,760. The ratable value increased from £10,029,967 in 1868 to £18,623,910 in 1890.

The coast is level, free from rocks, and has numerous estuaries stretching far into the mainland. Its ports are the only ones accessible to large vessels between Milford Haven, in South Wales, and the estuary of the Clyde. This, with the ease with which the coast is approached from the interior, has made the county the principal outlet for the commerce of the country in a westerly direction, one-third of the whole foreign trade of Great Britain being carried on from its ports. The chief rivers are the Mersey, Ribbles, Lune, Wyre, Kent, Leven, and Duddon. The rainfall in Lancashire is sometimes twice as great as on the east coast; the climate is mild. The lofty hills on the east shelter it from the land winds, while the prevailing winds, those from the south and west, are rendered mild from the effect of the Gulf Stream. This humidity of climate is said to contribute to the superiority of the finer kinds of cotton threads manufactured in Lancashire. An outlying portion of the county, called Furness, 25 miles long by about 20 wide, is separated from the main portion by Morecambe Bay, and seems as if it properly ought to belong to the Lake District. Coniston, Esthwaite, and Windermere lakes lie within the borders. The highest point here is 'Coniston Old Man' 'alt man,' or the 'high rock' 2633 feet above the sea. The larger division

is intersected in the north and east by branches of the hill-system which runs southward through the counties of York and Derby, the chief eminences being Pendle Hill (1831 feet), Bleasdale Moor (1709), Bondswood Hill (1689), and Rivington Moor (1545). The soil is peaty in the upland districts, but for the most part a fertile loam in the flats. Oats and potatoes are general crops; wheat grows well in the southern division. Coal is the chief mineral product, the coalfield being estimated at 217 sq. m. in extent. The latest estimate of the quantity raised in one year amounted to 19,120,000 tons. Limestone and iron are common in the north. Lead, copper, sulphur, and fireclay are also found. The whole surface of the county is covered with a network of canals and railways which connect the principal manufacturing and commercial centres (see MANCHESTER, LIVERPOOL, PRESTON, BLACKBURN, &c.). Lancashire is the great centre of the cotton manufacture of the world, having about two-thirds of the entire trade (see COTTON). The other textile manufactures, such as woollens, silk, carpets, are likewise of considerable importance. It is pre-eminent in the manufacture of engineers' tools; and the making of all kinds of iron and steel machinery is extensively carried on. Shipbuilding, sailmaking, the manufacture of boots and shoes, hosiery, and kindred trades are also in a flourishing condition. The county returns, since 1885, twenty-three members to parliament (formerly eight), besides those for the boroughs. The phrase, 'Lancashire Witches,' which is now used as an expression of admiration for the young maidens of the county, arose from the prevalence of the crime of witchcraft in Lancashire in the reign of James I. So many as twenty witches were tried and executed at the Lancaster Assizes of 1612. Twelve of these were the witches of 'Pendle Forest,' and eight belonged to the witches of 'Samblesbury.' A few years previously, Ferdinand, fifth Earl of Derby, was supposed to have been murdered by witchcraft. At the time of the Reformation the Roman Catholic party was extremely strong in Lancashire, and religious houses of great wealth and influence existed in every district, twenty-two being suppressed by order of King Henry VIII.; this included the abbeys of Furness and Whalley (see FURNESS). An unusually large proportion of the land-owners still adhered in the reign of James I. to their old faith, and in 1604 six priests were tried at the Lancaster Assizes and executed. Those connected with the Gunpowder Plot expected to rouse the Catholics of Lancashire, but entirely failed to do so. The whole of the district was continually unsettled and full of discontented recusants, some of them of Roman Catholic and others of Puritan opinions. The people of Lancashire have long been noted for their love of music and natural history, there being amongst them many working-men who are botanists and entomologists of repute; while their politics and opinions have had such influence in the country that the proverb has arisen that 'What Lancashire thinks to-day England says to-morrow.' Amongst eminent names connected with Lancashire are those of Mrs Gaskell, Mrs G. L. Banks, Miss Martineau; of Roscoe, De Quincey, Sir Robert Peel, Horrocks, Dalton, Hodgkinson, Joule, Greg, Bamford (the weaver poet, 1788-1872), William Henry the chemist, Sir W. Fairbairn, Sir J. Whitworth, James Martineau, Gladstone; and names connected with the success of the cotton trade, as John Kay (inventor of the fly-shuttle), Crompton, Arkwright, Hargreaves. The Lancashire dialect, renowned for terseness and vigour, is illustrated in works by J. Collier ('Tim Bobbin'), Ben Brierley, Edwin Waugh. See maps at MANCHESTER and at LAKE DISTRICT.

See Baines, *Lancashire* (1836; new ed. by Croston, 1888); Espinasse, *Lancashire Worthies* (1873-77); Nodal and Milner, *Dialects* (1882); and works by Bunterworth (1841), Grimdon (1866, 1882, 1892), Axon (1883).

Lancaster, the capital of Lancashire, is picturesquely situated on an eminence on the left bank of the Lune, 7 miles from its mouth, 51 $\frac{1}{2}$ N.W. of Manchester and 231 N.W. of London by rail. The ancient castle, which overlooks the town, was built on the site of a Roman castle, and was restored by John of Gaunt. 'Time honoured Lancaster;' it is now used as the county gaol. The church of St Mary (15th century) contains some good oak-carvings and stained glass. The Ripley Hospital is an asylum for orphan children. The houses are built of the freestone quarried in the vicinity. The Lune is here crossed by a bridge of five arches, erected in 1788, and by an aqueduct carrying the Lancaster Canal across the river. Owing to the sanding of the Lune, large vessels have to unload at Glasson, 5 miles distant. The chief manufactures are furniture, cotton, silk, oil-cloth, table covers, machinery, and railway plant. A public park was presented in 1881. Sir R. Owen, the anatomist, and Dr Whewell were born at Lancaster. In 1698 the town was nearly burned to the ground. A very ancient municipal borough, it returned two members to parliament from 1547 to 1867, when it was disfranchised for corrupt practices at elections. Pop. (1881) 20,663; (1891) 31,038. See works by Hall (1843) and Simpson (1852).

Lancaster, (1) capital of Fairfield county, Ohio, on the Hocking River and Canal, 32 miles S.E. of Columbus, with machine-works and railway shops. Pop. (1890) 7555.—(2) Capital of Lancaster county, Pennsylvania, 69 miles by rail W. of Philadelphia. Besides a large court-house and numerous churches, it contains the Franklin and Marshall (German Reformed) College, and a theological seminary of the same body. There are large cotton-mills, and tanneries, breweries, potteries, and a number of other manufactures; and extensive warehouses for tobacco have been built. Founded in 1730, Lancaster was the capital of the state from 1799 to 1812. Pop. (1870) 20,233; (1890) 32,011.

Lancaster, DUCHY OF, was created in the reign of Edward III, the dignity of county palatine being at the same time conferred upon the duke. The heiress marrying John of Gaunt, son of the king, the duchy was settled upon him and his heirs for ever by royal charter in 1362. Henry IV., third Duke of Lancaster, on his accession to the throne, passed a law in which it was provided that the inheritance of the house of Lancaster should be held by him and his family separate from the crown-lands. Edward IV., in 1461 ordained, with the consent of parliament, that the duchy of Lancaster should be annexed to the crown, but 'held separately from all other hereditaments.' This arrangement has continued until the present time, and the affairs of the duchy have thus enjoyed an independent administration, and formed no part of those hereditary revenues in view of which the Civil List was granted. The revenues of the duchy have increased from £29,000 in 1847 to £86,284 net at the end of 1888, the payment to Her Majesty at these two periods being respectively £12,000 and £50,000 sterling. These proceeds are wholly exempted from parliamentary control, except that the annual account for receipt and expenditure is presented to parliament. The chancery of the duchy of Lancaster is still a crown-office, and was at one time a court of appeal for chancery of the county palatine, but is now merely nominal. The administration of justice has since 1873 been assimilated to that of the rest of

England. The office of chancellor is a political appointment; it is the practice to confer it on a statesman of eminence, frequently a member of the cabinet, who is expected to devote his time to such larger questions occupying the attention of government as do not fall within other departments. The emoluments of the office are about £2000 a year. For the House of Lancaster, see HENRY IV., V., VI.; and ENGLAND, Vol. IV, p. 351.

Lancaster, SIR JAMES, an English navigator who commanded the first fleet of the East India Company that visited the East Indies in 1600-3, and on his return home was knighted. He had previously been a soldier and a merchant in Portugal, had visited the East Indies on his own account in 1591-94, and in 1595 had captured Pernambuco in Brazil. He was one of the original board of directors, and afterwards did much to promote the voyages of Waymouth, Hudson, and Balbin in search of the North-west Passage to India. The strait leading westwards from the north of Balbin Bay was in 1616 named Lancaster Sound by Balbin. Lancaster died in May 1618. See Sir Clements R. Markham's *Voyages of Sir James Lancaster* (Hakluyt Soc. 1877).

Lancaster, JOSEPH (1778-1838). See BELL (ANDREW), EDUCATION.

Lancaster Gun, a species of rifled cannon, named after its inventor, which had a bore of oval section. It failed during the Crimean war, and was superseded.

Lancaster Sound, a western outlet of Balbin Bay, in 74° 20' N. lat., connected with Boothia Gulf on the south by means of Prince Regent Inlet. Though this opening into the Arctic Ocean was discovered by Balbin in 1616, it was first navigated by Parry in 1819.

Lance, GEORGE, painter of fruit and still-life, was born at Little Easton, near Dunmow, in Essex, on 24th March 1802. He studied under Haydon, but discovered that his strength lay in painting fruit, game, and similar subjects. Specimens from his brush in this line were exhibited year after year at the Royal Academy and British Institution. His admission that he had 'restored' parts of Velazquez's 'Boar Hunt' caused a stir of controversy in 1853. Lance died at Sunnyside, near Birkenhead, on 18th June 1864.

Lancelet. See AMPHIOXUS.

Lancers, a branch of Cavalry (q.v.) introduced into the British service in 1816.

Lancet-window. See EARLY ENGLISH.

Lancewood, a wood valuable for its great strength and elasticity. It is produced by the small tree *Gualteria cecata* (natural order Anonaceae). Another species, *G. laurifolia*, yields the wood called White Lancewood, which, however, is not much used. Lancewood is of great value to coach-builders, by whom it is used for shafts and carriage-poles, for which it is especially fitted. The part used is the main trunk of the tree, which is very straight, and rarely more than 9 inches in diameter with the bark on. It comes in small quantities from the West Indies, chiefly from Jamaica.

Lancing College, or ST NICHOLAS COLLEGE, a well-known boys' school, conducted on High Church principles, and situated at Lancing, 8 miles W. of Brighton, on the south coast of England. Founded in 1848, it has branches at Shoreham, Hurstpierpoint, and Ardingly, all like Lancing, in Sussex.

Land. See EARTH, GEOLOGY, LITHOLOGY, WATER; also LAND LAWS, AGRICULTURE, SOILS.

Landau. See CARRIAGE.

Landau, a town of the Bavarian Palatinate, 11 miles W. of the Rhine and 17 SW. of Spire. Founded and made an imperial city in the 13th century, it has some interesting old churches, and played a prominent part in history as a fortress. During the Thirty Years' War it was taken eight times; in 1688 it was fortified by Vauban for Louis XIV., but surrendered four times during the war of the Austrian succession. In 1816 Bavaria became mistress of it; and in 1870-71 its fortifications were levelled to the ground. Pop. 11,395.—Landau, another town of Bavaria on the Isar, 72 miles NE. of Munich, has 3165 inhabitants.

Laudaur, a sanitary station in British India, in Dehra Dun district, North-west Provinces, forming part of the town of Mussooree (or Masuri; pop. 3106). It is on the slope of the Himalayas, 7459 feet above the sea.

Land-crab. See CRAB.

Lander, RICHARD, the discoverer of the mouth of the Niger, was born at Turro on 8th February 1804, and in 1825 accompanied Clapperton as his servant to Sokoto. There Clapperton died, and Lander, returning to England, published an account of the expedition. The British government then entrusted to him and his brother John (1807-39) the prosecution of further researches along the lower course of the Niger. In 1830 they proved that the Quorra, or Niger, falls by many mouths into the Bight of Benin. They published a *Journal of an Expedition to Explore the Niger* (3 vols. 1832). In the course of a third expedition in the same quarter, Richard Lander was wounded by the Niger natives, and died in consequence at Fernando Po on 2d or 7th Feb. 1834. The story of this third journey is contained in Laird and Oldfield's *Narrative of an Expedition into the Interior of Africa by the River Niger* (2 vols. 1837).

Landerneau, a small seaport of France, stands at the head of the harbour of Brest, 12 miles by rail NE. of Brest; it has linen manufactures, tanneries, candle-works, and shipbuilding. Pop. 8903.

Landes, a maritime department of southern France, one of the largest and most thinly peopled in the country, is bounded on the W. by the Bay of Biscay. Area, 3598 sq. m.; pop. (1876) 303,508; (1891) 297,842. The chief river is the Adour (navigable). The greater portion of the department consists of the *landes*, tracts of barren sand, interspersed with marshes and forests of pine and oak and cork, forming one of the dreariest regions in Europe. The inhabitants are mostly of Gascon race, small and the reverse of robust in appearance, yet capable of great endurance. They herd sheep (no longer requiring to traverse the marshes on stilts), grow wine, and extract the products of the forests (timber, resin, cork, charcoal, &c.). Fowling and fishing also yield good returns. The Bayonne hams are obtained from pigs bred and fed in the *landes*. Besides wine, the soil is made to yield rye, maize, wheat, &c., especially in the hilly district called Chalosse, to the south of the Adour. By means of draining operations and the planting (since 1787) of forest trees rapid progress has been made in the reclamation of the soil and its cultivation. Although it has a coast-line of 75 miles long, the department does not possess a single harbour. A belt of sand dunes, 2½ miles wide and reaching 300 feet in height, fringes the sea-shore from north to south. About 20,000 tons of iron ore are smelted annually. The mineral springs of Dax were known to the Romans. The railway from Bordeaux to Bayonne passes through the district from north to south. The department is divided into three *arrondissements*, Mont-de-Marsan, St Sever, and Dax. Capital, Mont-de-Marsan. See FRANCE, Vol. IV, p. 774.

Landgrave, a title of superior distinction borne by certain counts (*graf*)—e.g. of Thuringia and Hesse—in the former German empire. They were the constitutional successors of the old rulers (counts, *grafe*) of the original counties (*graue*) of the German empire, and as such claimed the rank of princes (of the first class) of the empire.

Landguard Fort. See HARWICH.

Land Laws. Land being the universal and necessary basis of existence of the human race, it has in all countries been deemed to be subject to rules of use and possession established by the community. Of these rules in the earliest stages of society we have no written record, for they were in force before writing was invented. But we are able to trace their probable origin and first development partly from tradition, partly from customs which survive in later periods, and partly from investigation of the systems in force in rude nations when they first come within the view of competent observers. The formation of rules begins when civilisation or population has advanced so far as to render the regulation of conflicting rights desirable. Prior to that time the only law was that of the strongest: each man or each tribe occupied what he or it could conquer, and so much as it was within the power of either to defend from hostile aggression. Hunting, and afterwards pasturage, were the only uses to which land was then devoted. But as the tribes grew in numbers, and a nomad life became fatiguing, or inadequate to supply the means of existence, incipient agriculture led to the establishment of settlements more or less permanent. It is at this stage that we begin to meet with the recognition of rules for the regulation of culture and possession. The Roman writers, who examined with marked interest the contemporary institutions of their German enemies, show us one of the earliest stages of settled life. The wealth of the tribe lay still in herds of cattle, but a portion of the land around the villages was cultivated. This land was annually allotted to heads of families, and was changed in rotation from one to another, so as to ensure equality. Such arrangements survive in Europe to the present day. In Servia and some of the adjacent principalities the family property is still held in some degree in common, and every member of the household is considered to have a right to reside in the family dwelling, and to share in the produce of the family fields. The Russian *mir*, or village, preserves similar characteristics. It is a community recognised by the state as joint-proprietor of the village lands, and jointly responsible for the taxes. The lands themselves, with their apportionment of taxes, are allotted by the community among its several families. Where the land is poor the division is seldom changed, but where it is rich a fresh arrangement is made at frequent intervals or even every year. This village system prevails also in India, though there the division has become permanent. In Great Britain, as will be seen hereafter, its existence was unquestionable, and traces of it survive even at the present day in the customs and nomenclature of numerous districts.

Such rudimentary systems are, however, from their own nature destined to extinction as population increases. The family grows into the village, but the village finds its bounds restricted more and more by the pressure of neighbours, while every year the number of mouths to be fed within its limited space becomes larger. Thus more labour and more manure must be given to the soil to extract from it increased return, and the individual who has made his allotment more fertile than his neighbour's does not willingly exchange it for one which has been comparatively neglected. If he

has either power or influence, which probably his natural energy will procure for him, he insists on retaining his own plot, and on handing it on to his own family. As all who are in the like position will make a like claim, it easily becomes established as a right, and the more that labour is employed on the separate property the more impregnable does the title tend to become. This stage has always been reached by the time that the nation in which it prevails comes to have a recognised code and written laws. The laws of the Israelites (it matters nothing whether prescribed by Moses, or compiled at a later date from tradition, or from theories of sound policy and justice) recognised that the tribe had a title to a certain district, but that each member of the tribe had an absolute and indefeasible right to his own separate portion of land. This right was guarded by a law, at once of equal partition and of entail, under which alienation was only valid for a term of forty-nine years. In Greece private ownership was fully established. In Rome every family had its permanent share allotted to it. The survival of the idea of community was limited to the common lands, which by conquest became of immense extent. But the object of the agrarian agitation which covers so many pages of Roman history was not to revert to the original community of possession, but only to secure that of the remaining common lands each citizen, however poor, should be deemed entitled to receive a grant for his future possession in exclusive and private property.

From this general sketch of the origin of private property in land we may now proceed to consider its development in modern times, and especially in the United Kingdom.

The system of ownership of land in England under the Saxons was substantially the same as among their Germanic ancestors. There was still ample space for all. The village community remained the unit of social arrangements, and held generally large areas of forest or heath in common, on which every villager had a right to pasture stock. The small area of land under tillage was appropriated to individuals, sometimes in understood permanence, especially where a family held a position of pre-eminence, sometimes under a custom of more or less frequent redivision or appropriation. This village system, with its rights of common, survived far into the period of Norman occupation; and in numerous districts it may still be traced in the divisions and names of fields, and in the local customs. But a vast change of principle was introduced by the Norman Conquest, bringing with it the ideas of feudalism which had grown up on the Continent. Under this theory the whole land of the realm was deemed to be vested primarily in the sovereign. By him it was granted in knight-fee to certain nobles or gentlemen, who in return were bound to perform all duties of a vassal to his lord, and in especial to furnish a contingent of armed men to support him in war. Default in these duties involved forfeiture, but if performed punctually (or so far as the lord could enforce punctuality) the vassal was supreme in the territory granted to him. By degrees he gained the right of subinfeudation—i.e. of making similar grants of portions of his land to others, to be held by them as his vassals. This privilege was abolished in England by the statute *Quia Emptores*, 18 Edw. 1., which recognised the right of a vassal to sell, but required that the purchaser should hold subject to the original lord. At a still later period the owner of land in England acquired the right of devising land by will (32 Henry VIII. chap. 1). But the system of feudal tenures was swept away in England by the statute 12 Charles II. chap. 24, which abolished all services,

already long fallen into disuse, of the nature of military aid to the sovereign. Meantime the character of the land laws had been chiefly affected by the struggle between parliament, representing the wishes of the great nobles, the courts of law, guided by judges sprung mainly from the people, and the Court of Chancery, which in its earlier stages was inspired by the church. The statute *De Donis* established entails. But these were defeated by fictions, called fines and recoveries, sanctioned by the courts of law. Parliament passed acts for bidding alienation of lands in mortmain, chiefly in order to prevent the aggrandisement of the church. But these were defeated by the Court of Chancery giving effect to trusts for religious corporations. Parliament by the Statute of Uses, 27 Henry VIII. chap. 10, annulled such trusts. But again the judges defeated the statute by declaring that it did not apply where a trust was created to hold for another, who again was to hold for a third person. At last a device was hit upon by the ingenuity of lawyers under which the effect of entails has been attained by means of what are called Settlements, under which the operation of natural motives is brought into play to induce each successive owner to restrict himself to a life-interest only. By this system, which applies to a very large proportion of the land of England, estates are preserved in families, from one generation to another, but at the cost of grave evils, arising from the restraint placed on the powers of the actual possessor.

In Scotland the feudal system superseded that of clanship; and the chief of the clan, who was at first only the village headman, acquired in the eye of the law the sole title to the land which supported the community. But subinfeudation was never abolished in Scotland. It formed the basis of the system of conveyancing till past the middle of the 19th century, and it is still in practical use in the creation of 'feus.' Entails also, in all their strictness, were recognised as valid from the year 1696, and only since 1848 have been subjected to restraints resembling those which were from the first imposed upon them in England by the fictions which were sanctioned by the courts of law. Legislation subsequent to 1848 has enabled every owner under an entail to acquire the fee-simple on paying to the next heirs the estimated value of their interests.

Feudalism held sway in France down to the Revolution. The introduction of modern ideas of taxation even aggravated its hardships, for the great nobles secured exemption from these imposts, which thus fell the more heavily on their vassals. Both in France and Germany the vassals were also heavily burdened with the obligation of forced labour, partly due to the state for the maintenance of roads, &c., but chiefly to the immediate lord, who thus obtained the advantage of gratuitous cultivation for his own lands, while the peasantry were left to devote more inconvenient seasons to the work of their small farms. In France this system was swept away by that Revolution to which it had so largely contributed. The *Codé Napoléon* now regulates the law, which, except that on death it directs the compulsory division of land among the whole of the children, practically resembles the law of England. In Germany the feudal system disappeared under the celebrated legislation of Stein and Hardenberg. To purchase their relief from the duty of forced labour and other exactions of the lords the peasantry surrendered a portion of their lands to the lords, and were declared to hold the remainder free from any service. Land banks were at the same time established, which made advances to those who desired to buy up rights of common affecting their lands, or to commute rents for a payment in money.

In northern Europe feudalism took no root, and land has generally been held by small freeholders who were the cultivators. The system passed from Scandinavia to Orkney and Shetland, where the same tenure exists to a considerable extent under the name of *udal* right.

The principles which are involved in the ownership of land receive illustration in modern systems where new or unappropriated lands have to be settled. Generally speaking, first occupation is recognised in such cases as a sufficient title to exclusive and permanent ownership. There is, however, an unwritten law almost universally in force that occupation must be actual, and not merely an assertion of right over more area than the settler can actually work. This understanding crystallises into the rule that the occupation must be only of a limited space or 'claim,' and that actual labour of a specified amount must be expended on it within a definite period. Such rules are instituted wherever bodies of men establish themselves, whether as miners, shepherds, or farmers. When the community has existed for a short time, and is so far permanent as to have organised a government, these or similar rules are enacted as laws, and the authority of the whole community is asserted over such portions of territory as lie within its powers to defend, and which are not yet appropriated to individuals. The state generally sells these in plots to private individuals for a certain fixed price. This system prevails both in British colonies and in the United States. In the latter the remaining public lands are vested in the separate states, several of which have established a 'Homestead Law,' under which each naturalised citizen is entitled to claim a free grant of a certain portion of unoccupied land on condition of actually cultivating it. (For the present division of land in Britain, see AGRICULTURE, Vol. I, p. 102; see also UNITED STATES, &c.)

From the foregoing sketch it may be seen that the fundamental idea of ownership in land, in the leading systems of village communities and of feudalism, is that it is ultimately vested in the state or nation. But it is equally apparent that individual ownership, subject to such services or other equivalent as the state may demand, is universally recognised as the most useful form in which land can be employed. It applies the stimulus of individual profit and enjoyment to the culture and improvement of the soil. Under this influence an enormous amount of capital has in all countries, but in the most marked degree in Great Britain, been invested in the reclamation of the land from its original state of nature, whether as forest, prairie, or swamp. The fee-simple value of the land as it at present exists, in the majority of cases, represents not the original value, but little more, very often considerably less, than the mere expenditure of capital within the last century on erection of farm-houses and farm-buildings, cottages, and fences, on making roads, on draining, levelling, embanking, warping, or such other improvements as the situation demands. These outlays have been made on the understanding that the state would deal with them on the same principles as with investments in factories, railways, dwelling houses, or other species of recognised individual property—i.e. that it would apply to them the general rules of ownership and succession established in the community at large. Such rules permit all property whatever to be taxed and even to be appropriated by the state when the public good requires; but they require that no one class of owners shall be treated differently from others, and that if anything is taken for the public benefit the public shall pay its fair market price to the owner.

A number of schemes have been proposed for what is vaguely called 'nationalisation of the land.' These all start from the principle which has been seen to form in most countries the basis of land tenure, that the land is the property of the nation; and their object is to assert this principle in the direction of recovering possession for the nation from individuals. The first of these proposals in the present day was made by Mr Herbert Spencer, who, in his *Social Statistics*, suggested that land should be held by the state and let for short terms to the highest offerer. Subsequently Mr George (q.v.) proposed that, without divesting the present holders, land should be taxed in their hands to the amount of the full rental value, excluding only so much value as had arisen from improvements effected by the present holders or their ancestors. Dr Alfred Russell Wallace has proposed that the state should acquire the land of the country on payment of compensation to present owners, such compensation in his first suggestion being limited to their life-interest, but in later editions being extended to the value in fee-simple. He also urges adoption of a modified form of the Homestead Law of the United States, by which every citizen should be entitled to claim a sufficient extent of ground for a house and garden out of land in any situation not already devoted to that purpose. For this he would pay rent to the state. The agricultural land of the country in Dr Wallace's scheme is to be let by the state to tenants in perpetuity, subject to the obligation of 'occupying ownership'—that is to say, of being farmed by themselves without intervention of tenants. Other ideas, less distinctly formulated by their authors, contemplate the general division of the land into small portions sufficient only for the maintenance of a single family, which is recommended as 'restoring the people to the land;' while others suggested the ultimate cultivation by the community, under undefined arrangements of a socialist character. Thus it cannot be said that, as yet, any approach to agreement on a distinct system has been arrived at by the advocates of the idea of nationalisation of the land. The fundamental question whether any or what compensation is to be made to existing holders has yet been scarcely debated; the shock to the security of property if one species be confiscated has not been estimated; the difficulty of discriminating between original value and value added by outlay of capital has not been approached; and finally the question whether the nation would gain on the one hand by the transfer from one set of holders to another, or on the other by the substitution of state for individual cultivation, has not in any quarter been entered on.

As a middle scheme between existing private ownership and nationalisation, Mr Mill brought forward the doctrine of the right of the state to what he called the 'unearned increment' of land. His idea was that when land rose considerably in value from the mere fact of its proximity to a town, from a general rise of prices, or from other circumstance not dependent on the skill or capital of the owner, the public should be entitled to appropriate the rise to itself in the shape of a rent or tax. The idea of an 'unearned increment' in the value of agricultural land is, however, scarcely tenable, as it is the fact that any such increment is due (as has been shown above) mainly to the investment of capital by successive owners. The application of the doctrine would, therefore, occur generally in the case of land adjoining towns. But the growth of towns is largely due to private enterprise stimulated by the hope of profit. The confiscation or prohibition of such profit, which would be involved in a law permitting a municipality to take

possession of land or buildings at its original value, would annul the operation of private enterprise. This is an entirely novel factor in modern progress, and one of which the full effects can hardly be forecast.

Under the name of 'Betterment,' the increase of value due to municipal improvements in restricted areas (e.g. a new street, bridge, or the like) has in America been subjected to a graduated tax, and this proposal has also been lately brought forward in Great Britain.

The mischiefs arising from the aggregation of large extents of land in the hands of one owner have also been the subject or motive of legislative proposals. The statute book contains one notable effort to restrain it, in the Thellusson Act (q.v.). Such aggregation is, however, fostered by entails and by the rule of primogeniture, while the subdivision of land is the result of laws of succession which prescribe that land shall be divided equally among children. That this should be done in cases of intestacy, while the parent is still allowed the option of bequeathing the whole to one son, would be the effect of merely abolishing the rule of primogeniture. But the *Code Napoleon* makes equal division among children a compulsory rule. The rule itself is, however, much older in many countries, and in the United Kingdom it has existed from time immemorial in the Channel Islands. One evil which flows from it is the excessive *morcelement*, as it is termed in France, of estates in land. But this result is partly attributable to the system of subdividing every separate portion of the paternal estate, which obviously is not a necessary condition. In practice a restraint on inconvenient minuteness of subdivision is found in the habits of the population. Where these tend towards emigration (which is largely the case in the Channel Islands, but not in France) the inheritor of a very small fraction of land readily sells it to a neighbour, and uses the price to set himself up in trade, or for the purpose of emigration. A graver evil is that the same family consequences follow from compulsory division as were shown by Bacon to attend entails on the eldest son. Children are apt to attend with impatience the father's death, which puts them in assured possession of their patrimony, and filial duty is weakened by the knowledge that disobedience involves no penalty. A middle course has been suggested—that children should have absolute right to only a portion of the paternal estate (as is the case in regard to personal property in Scotland under the law of Legitim, q.v.), but that the parents should have power of bequest over the remainder. To arrest aggregation it has also been proposed that no owner of property, whether in land or personally, should be entitled to bequeath more than a fixed amount to any single individual, though with full power to bequeath the whole of the estate to such persons as he chooses, subject to the above restriction.

Land has also been employed in all countries for the subsidiary purpose of forming a security for debt, as by mortgage in England or heritable security in Scotland. This also tends to aggregation, as it relieves the owner from the necessity of selling a part when in need of ready cash. Estates so burdened are, however, little better than leaseholds. The owner is necessarily short of capital to improve them, while led to keep up the appearance of greater wealth than he actually possesses. The lender of the money is also a strict creditor, seldom inclined to grant indulgence in time, and never to concede abatement in amount even in bad seasons. The evil is very ancient and very widely spread. It was the occasion of many insurrections in Rome, and at

this day is even more prevalent on the Continent than in Britain. Vast tracts of land in eastern Europe are passing from the hands of the peasantry into those of money-lenders, and in India the same class of speculators, availing themselves of the strictness of British law for the recovery of debt, are becoming a scourge of the country. The Jewish law met the mischief by the laws against usury, and by the law of restitution at the jubilee. In 1880 the suggestion was offered (Boyd Kinnear, *Principles of Property in Land*) to attack the evil at its root by declaring that land shall not be a subject of preferential debt, while liable like all property to sale for payment of general debt. If such a rule were established no one would lend on land, and the owner who desired to raise money would be compelled to sell a portion. What he retained would be free from debt, what a purchaser acquired would be equally free, and every possessor would be a real, instead of fictitious owner of a smaller but more beneficial estate.

The cultivation of land may be either by the owner or by a tenant. The former is the natural, and almost always the most advantageous method, in the interests of the community, for it tends to induce the largest outlay on improvements which bring enhanced returns. The first departure from this idea takes the form (unknown in Britain, but common on the Continent, and not infrequent in the United States) of cultivation on shares, or *métairie*. Under this arrangement the landlord furnishes land and generally stock, the tenant gives the labour, and the produce is shared in certain proportions, frequently in moieties. It involves a close superintendence by the landowner or his steward to ensure that the stock is not made away with, and that his fair share is handed to him either in kind or in cash. The next stage of the arrangement forms the system, once universal in Scotland, of 'grain rents,' where the tenant binds himself to pay annually the value of a fixed quantity of different species of grain according to the market prices then prevailing, these being annually ascertained in Scotland by the 'striking of the Fairs' (q.v.). The last stage is the agreement to pay a fixed money rent irrespective of crops or prices. It is preferred by tenants in times of prosperity, as it leaves them the whole benefit of increased crops or rise in prices. The term during which the arrangement continues is in foreign countries very generally seven or fourteen years, in Scotland usually nineteen; while in England it has been most frequently only from year to year, and in Ireland it was often for lives. The last is the worst, because the most uncertain of all. The lease from year to year has gained a sort of expectation of permanency; the lease for definite terms enables the tenant to make positive arrangements, but it has the disadvantage of disposing him to cultivate less liberally as the termination approaches. To meet this the Agricultural Holdings Act entitles him to payment by the landlord for the unexhausted value of certain specified beneficial outlays made during his tenancy.

In Ireland the majority of the tenants prior to 1832 held under lease; but after that date they were gradually converted into yearly tenants. The prevailing rule, however, was that they continued in possession, at such rents as they could pay, from generation to generation. In 1860, and subsequently in 1870, 1881, and 1887, the legislature introduced successive restraints on the landlord's right of eviction. The position of tenants subsequent to the last-named statute is briefly as follows. They all hold in permanence, subject to eviction only in the event of non-payment of rent. Even if evicted on that ground they may recover

possession by paying the arrears within six months after notice. They are entitled also, although existing, to receive payment for any permanent improvements they have made. They may sell or bequeath their right of tenancy at pleasure. The rent is fixed (if the tenant desires) by the Land Commissioners, after examination by valuers; but it is subject to revision every fifteen years—so, however, that it is not to be raised in respect of any improvements made in the interval by the tenant. During three years of low prices (1886-89) the tenant was entitled to obtain a new valuation and reduction, and all judicial rents were further reduced according to an official scale, based on current prices for each year. In 1882 an Arrears Act wiped out all arrears then due by tenants, on payment of only one year's rent. In 1870 the 'Bright clauses' granted advances by the state to the extent of two-thirds of the price to enable tenants to purchase the fee-simple of their holdings from landlords who were disposed to sell. The 'Ashbourne Act' in 1885 extended this boon to a sum sufficient to cover the whole price, and the tenant paying interest on this at 4 per cent. per annum for forty-nine years clears himself of the full amount. The amount to be thus advanced by the state was at first limited to £5,000,000. In 1888 £5,000,000 more were granted; and these sums being absorbed, a bill was in the session of 1890 introduced into parliament extending the sum to about £30,000,000, under some slight modifications. The Land Law Act of 1896 extends and simplifies the fixing of fair rents, simplifies purchase, and extends the powers of the Congested District Board and facilitates advances from the Land Commission.

For the land-tax imposed in Britain on land and houses for purposes of revenue in lieu of the ancient subsidies, tentages, tallages, tenths, and such occasional taxes, see VALUATIONS. The land-taxation and land revenue of India are discussed at p. 115 of this vol.; for the proportion of the land-tax to other sources of revenue in various countries, see CHINA, TURKEY, &c. See also the articles in this work on:

Agrarian Laws.	Entail.	Political Economy.
Agricultural Holdings Act.	Fen.	Rent.
Agriculture.	Fiefdom.	Sale.
Allotments.	Game Laws.	Socialism.
Capital.	George, Henry.	Tenants.
Commons.	Heir.	Tenure.
Commonism.	Homestead.	Tithe.
Conveyance.	Hypothec.	Village Communities.
Costs.	Labour.	Waste Lands.
	Mortmain.	Will.

The following works may be consulted: Von Maurer, *Geschichte der Mark-Verfassung in Deutschland* (1856), and other works; Nasse, *Ueber die mittelalterliche Feldgemeinschaft in England* (1869; Eng. trans. 1871); Laveleye, *Primitive Property* (Eng. trans. 1878); Maine, *Early Communities* (1871); Seebohm, *The English Villan Community* (1883); the 'Golden Club Essays,' *Systems of Land Tenure* (1870; new ed. 1881); Brodrick, *English Land and Land Laws* (1880); Wallace, *Land Nationalisation* (1882); Prothero, *The Powers and Progress of English Tenancy* (1888); the present writer's *Principles of Property in Land* (1889); R. M. Garner, *The English Landlord Interest* (1892); Shaw Lefevre, *Agrarian Tenure* (1893); Sir F. Pollock, *The Land Laws* (1885; new ed. 1896).

Land League. In Ireland, founded by Devitt (q.v.) in 1879, to purchase land for the tenants, and suppressed in 1881 as illegal. See IRELAND.

Landlord and Tenant. Primitive custom often recognised two classes of tenants those having fixed rights, who were in some sort owners or part owners, and those who derived their rights from the grant or contract of a superior. The British authorities in India have been compelled to take note of these primitive forms of tenure; in Bengal and elsewhere tenancy laws have been

passed for the protection of cultivating occupiers. In the Roman law tenancy appears in two forms. *Locution* is an agreement of letting and hiring; the rights of the parties are derived from the contract between them. *Emphyteusis* is tenure in perpetuity, or for a long term, at a fixed rent. Feudalism, as Sir H. Maine has shown, combines Roman ideas with primitive custom. The *dominus* of Roman law is a private person; the *dominus* of feudal law is the political superior of whom land is held. By the English common law, which was formed under feudal influences, the *dominium* of all lands was vested in the king as lord paramount; so that even a freeholder, holding to himself and his heirs for ever, is technically described as a tenant in fee-simple. When the freeholder makes a formal lease of his land, the lessee on entering acquires a limited interest which is protected by rules of common and statute law. A mere contract or agreement for a lease, not embodied in a formal conveyance, creates rights as between the parties, but it gives no interest in the land at common law. Equity, however, compels the lessor to fulfil his contract by executing a formal lease. A formal lease must be made by deed, unless it be a lease for three years or less at a rent equal to two-thirds of the improved value. An agreement for a lease must be proved by writing; and the Stamp Act requires that it should be stamped as if it were a lease. A tenant who has no formal lease or written agreement to show is, in strict theory, only a tenant at will; but if his landlord accepts rent from him he is entitled to a reasonable notice to quit. The English courts held long ago that a tenant from year to year was entitled to six months' notice, terminating with a year of the tenancy, and the Agricultural Holdings Act requires twelve months' notice in the case of agricultural tenants.

Under a lease or agreement, possession is transferred to the tenant during the term agreed. There is, on the landlord's part, no implied warranty as to the state of the premises, except in the case of a furnished house. A person who lets a house furnished is taken to warrant that it is in a habitable state. The landlord usually reserves the right to re-enter and put an end to the tenancy in case of non-payment of rent or other breach of covenant; but he is not now permitted to take full advantage of such stipulations in cases where the tenant is prepared to make pecuniary compensation for his default. Rent in arrear may be recovered by action, and also by the landlord's special remedy, Distress (q.v.). If a tenant fraudulently removes his goods in order to avoid a distress, the landlord may, within thirty days, seize and sell such goods wherever found, unless they have passed into the hands of a *bona fide* purchaser for value. The tenant has a right to assign his interest, or to sublet; but this right is, in practice, restricted by providing that the tenant shall not assign or sublet without his landlord's consent. An agricultural tenant had a common-law right to emblements, i.e. he might reap the crop he had sown, even if his term expired before harvest; and now an Act of 1851 enables a tenant to keep possession till the end of the year, though the interest of the person under whom he holds may have expired. Extensive powers of leasing have been given to tenants for life and other limited owners of settled land. In tracing the changes made by statute in the law of landlord and tenant, we observe that feudal and customary ideas have been giving way before the application of commercial principles. So far as England is concerned, the results of the change have been good on the whole. Landlords and farmers have been encouraged by the contract system to invest large sums in buildings, drainage, &c.; and a

large amount of food is thus raised with a comparatively small expenditure of labour. In Ireland the English system has been widely introduced; but the peasant farmers have always clung to primitive ideas and customary rights. They regard themselves as owners of the land, subject to a tribute rent, and they think it unjust that rent should be raised by competition. See LAND LAWS, REPAIRS.

For the English law of landlord and tenant, see the standard work of Woodfall; Irish legislation on this subject is expounded in Roche and Rearden's *Irish Land Code*. See also the Report of the Duke of Richmond's Commission, presented in 1882.

In the law of Scotland a lease assumes the form of a contract, binding on the parties; and by a statute of 1449 leases were made binding on singular successors—i.e. on those who may purchase from the lessor. If the lease be for more than a year it must be in writing, the term and the rent should be specified, and possession must be taken by the tenant. A written obligation to grant a lease is equivalent to a lease; and an agreement for a lease must be stamped as a lease. When the term of a lease has expired it may be continued from year to year by 'tacit relocation.' The remedies given to a landlord in respect of rent have been restricted by an Act of 1880, which abolishes the right of hypothec in respect of any land, exceeding two acres, let for agriculture or pasture. It has long been the practice of Scotch proprietors to grant farming leases for nineteen years. The Agricultural Holdings Act, 1883, is designed to give adequate security for tenants' capital invested in improvements; and the Crofters' Holdings Act, 1886, has conferred on small tenants in Highland counties rights somewhat analogous to the 'three F's,' as understood in Ireland.

See Hunter on Landlord and Tenant, and the Reports of the Richmond Commission (1882) and the Crofters Commission (1884).

In the United States the law of Louisiana is based on the civil law; in all the other states English principles seem to have been adopted. Distress has been abolished in some states, but the landlord's remedy is practically preserved to him by the law of liens and attachments. In case of non-payment of rent the landlord may enter and dispossess the tenant, on giving him the notice required by law (see Stimson's *American Statute Law*). Commercial principles have been more rigorously applied to land in America than they are in England or Ireland; no special protection or favour has been extended to agricultural tenants.

Landor. LETITIA ELIZABETH, was born in Chelsea, August 14, 1802. At an early age she contributed short poems to the *Literary Gazette*. Between the years 1824 and 1838 she published several volumes of poems, and three novels, besides contributing to 'Annuals,' the *New Monthly Magazine*, and the *Literary Gazette*. In 1838 she married Mr Maclean, the governor of Cape Coast Castle, and went out there with her husband at once. Two months after her arrival she died suddenly from having taken an overdose of prussic acid, which she had been in the habit of using as a remedy for spasmodic affections to which she was subject. Her poems and novels, written under the initials 'L. E. L.,' show genius, and were in their day exceedingly popular. See Life and Literary Remains, by Laman Blanchard (1841).

Landor. WALTER SAVAGE, was born at Warwick, 30th January 1775. He was the eldest son by a second marriage of Dr Landor, a medical practitioner in that town. His mother was Elizabeth Savage, of a well-known Warwickshire family. At the age of ten he was sent to Rugby School,

from which he was expelled for insubordination. After two years spent with a private tutor, Landor, now in his eighteenth year, entered Trinity College, Oxford. At the university he gave further proof of his impracticable temper—pursuing his own independent course of study, and taunting his political opinions so ostentatiously as to gain for himself the name of 'mad Jacobin.' For firing a gun into the room of a Tory undergraduate, and absolutely refusing to make any statement to the president, he was rusticated in 1794. He published a volume of *Poems* in 1795. Returning home, he shortly afterwards quarrelled with his father, and left the house 'for ever.' A reconciliation having been effected, Landor retired to South Wales on an allowance of £150 a year, with the liberty to live as he pleased. As the result of a diligent study of Milton and Pindar he published his *Gebir* in 1798. The poem found a few ardent admirers, and was the occasion of his lifelong friendship with Southey; but it failed, as it has done ever since, to find acceptance with the majority of those interested in poetry.

On the death of his father in 1805 Landor settled in Bath, where his style of living went beyond even his now considerable income. In 1808, with a band of volunteers raised at his own expense, he went to Spain to assist in the emancipation of that country from the yoke of Napoleon Bonaparte. The following year he purchased the estate of Llanthony in South Wales, where he mainly lived till 1814. Landor had bought the estate with the intention of doing all in his power for the good of his tenants and the neighbourhood in general. Before long, however, he quarrelled all round with his neighbours and his tenantry alike, and administered his affairs with so little judgment that ruin stared him in the face. In 1811 he had married Miss Thuillier, a step he took in the true Landorian manner, after a casual meeting with the lady at a ball. The union proved an ill-assorted one, and in 1814 he quitted her and crossed to France. Throughout all his domestic troubles Landor, who had in singular degree the faculty of forgetting the actual cares of life, had never ceased to occupy himself with literature. The most notable production of this period is his tragedy of *Count Julian*, which De Quincey has praised in the strongest terms, but which the majority even of Landor's admirers find defective in all the qualities indispensable to a successful drama.

After a short sojourn in Tours Landor, accompanied by his wife, who had rejoined him, proceeded to Italy, where, living in succession at Como, Pisa, and Florence, he remained till 1835, with the exception of a short visit to England. To this period belongs the best known of all his works, the *Imaginary Conversations*, a first instalment of which was published in England in 1831. A second quarrel with his wife in 1835 led to his return to England, where he settled in Bath till 1858. During these years Landor wrote much in prose and verse. As the most solid contributions to his fame should be specially mentioned the *Examination of Shakespeare* (1834), the *Pentameron* (1837), *Pericles and Aspasia*, and his *Hellenics*. The writing of Latin verse had from Landor's youth been one of his serious occupations, and in 1847 he published a collection of his Latin poems under the title of *Poemata et Inscriptiones*. In 1858 an unhappy scandal (see *Dry Sticks Fagottd*, by W. S. Landor), which involved him in an action for libel, again forced him to make his home in Italy. After an unsuccessful attempt to live with his family in Florence, by the advice and assistance of friends, chief among whom was Browning, he took rooms by himself in that city. Here, with health and faculties in wonderful

preservation, visited by men who have since become famous in literature and art. Landor lived till his death on 17th September 1864, assiduously composing to the last both in prose and verse.

By his singularly imposing personal appearance, his imperious will, and his massive intelligence, this 'unsubduable old Roman,' as Carlyle called him, was one of the most original figures among his contemporaries. A brief record of Landor's life perhaps unduly emphasises the least attractive aspect of his character. Irrational in the highest degree in the everyday conduct of life, he yet inspired affection and esteem in men whose opinions cannot be disregarded. Southey and Francis and Julius Hare were his friends of many years' standing, and in the latter part of his life, John Forster (afterwards his biographer), Charles Dickens, and others all testify to the essential nobility of his character. By a narrow circle of admirers Landor is ranked with the great names of English literature. In the sculpturesque severity of his verse they find a perfect reproduction of the finest work of the ancients. His prose they place even higher than his verse, asserting that a judicious selection from the *Imaginary Conversations* would be 'one of the most beautiful books in the language—that is to say, in the world.' For the majority even of cultivated readers, however, Landor holds by no means so supreme a place either as a poet or writer of prose; and the very subordinate place assigned to him in every history of literature clearly marks where he stands in the aggregate opinion of his countrymen. While it is admitted that there are 'shining elevations' in all his work, the general impression seems to be that his form, alike in his prose and verse, is essentially artificial and factitious, and that the subject-matter of both is largely vitiated by the same irrationality which displayed itself so grotesquely at every period of his life.

See Forster, *Life and Works of Landor*; Sidney Colvin, *Landor* ('English Men of Letters' series); Mrs Lynn Linton, *Reminiscences of Landor* (*Fraser's Mag.*, July 1870); Lord Houghton, *Monographs*; S. Wheeler, *Letters and Unpublished Writings of Landor* (1897); Swinburne, *Miscellanies*. Mr Boythorn, in *Black House*, embodies Dickens's impressions of Landor 'with his intellectual greatness bit out.'

Landrail. See CORN-CRAKE.

Landberg, a town in the Prussian province of Brandenburg, on the Warthe, 80 miles by rail NNE. of Berlin. Its industrial establishments include sawmills, machine-works, breweries, distilleries, &c.; there is a large trade in timber. Pop. (1885) 24,896; (1895) 30,483.

Landscape-gardening deals with the disposition of ground, water, buildings, trees and other plants which go to the composition of verdant landscape. Such in a broad sense is the definition of the art; for it may be employed to create a beautiful and harmonious scene where only nature in barren wildness reigned before, or to merely improve and adapt existing natural beauties and resources to the requirements of taste and convenience. Landscape-gardening has been practised from the earliest dawn of civilisation, but little of a reliable kind is known of the style or features of the gardens of the Jews, the Phœnicians, Assyrians, or even those of the ancient Greeks. All that we learn from Greek writers respecting the character of their gardens is that they afforded shade, coolness, repose, freshness, and fragrance. The Greeks cultivated the sister art of architecture so well as somewhat to neglect gardening; hence Lord Bacon's remark in his *Essay on Gardens*, that 'when ages grow to civility and elegance, men come to build stately sooner than to garden finely,' as if gardening were the greater perfection.

The Romans introduced landscape-gardening into Britain; but the art was lost when the country was abandoned by them to the Saxons. As, however, it had meantime been fostered in France, it was probably reintroduced by the Normans. Henry I., according to Henry of Huntingdon (*Hist. lib.* vii.), had a park (*habitationem ferarum*) at Woodstock, and it is conjectured that this park may have surrounded a magnificent Roman villa, the ruins of which—covering about 6 acres in extent—were discovered on the Blenheim estates early in the 19th century. If the conjecture is well founded, Blenheim may be regarded as the most ancient site as well as the grandest example of landscape-gardening in Britain—according to many, it is the grandest in Europe. William Kent (1684-1748) and Lancelot Brown (1715-83), better known as 'Capability Brown,' may be considered as the founders of modern English landscape-gardening. See works by Loudon (1822), Repton (1840), F. R. Elliott (1878), and H. E. Milner (1890).

Landseer, SIR EDWIN HENRY, an English animal-painter, son of the engraver John Landseer, A.E.R.A. (1769-1852), was born in London, 7th March 1802. He was carefully trained by his father to sketch animals from life, and began exhibiting at the Royal Academy when only thirteen; but the first work that brought him prominently before the public was 'Fighting Dogs getting Wind,' exhibited in 1818. Down to about 1823 he was content to reproduce the natural expression and character of animals; after that date his animal pieces are generally made subservient to some sentiment or idea, without, however, losing their correctness and force of draughtsmanship. Dogs and deer were his favourite and best subjects; the scene of several fine pictures is laid in the Highlands of Scotland, which he first visited in 1824. In 1826 he was elected an A.R.A., in 1830 an R.A., and in 1850 was knighted. Among his most celebrated pictures are 'The Cat's Paw,' 'The Illicit Whisky-still,' 'High Life and Low Life,' 'King Charles Spaniels,' 'Jack in Office,' 'Suspense,' 'Bolton Abbey,' 'Highland Shepherd's Chief Mourner,' 'Dignity and Impudence,' 'Peace and War,' 'Laying down the Law,' 'The Challenge,' 'The Sanctuary,' 'Monarch of the Glen,' 'Stag at Bay,' 'The Random Shot,' 'Night and Morning,' 'The Children of the Mist,' 'Deer-stalking,' 'Flood in the Highlands,' 'Man Proposes, but God disposes,' and 'Swannery invaded by Sea-eagles.' The bronze lions at the foot of Nelson's Monument in Trafalgar Square, London, were modelled by him. Landseer was elected president of the Royal Academy in 1866, but declined the honour. The last dozen years of his life were clouded by much mental suffering, and he died October 1, 1873. He is buried in St Paul's. Most of Landseer's best pictures are well known from the excellent engravings of them done by his elder brother THOMAS (1796-1880). Another brother, CHARLES (1799-1879), was a painter of historical scenes. See *Landseer* by F. G. Stephens (1880), and Loftie's *Landseer and Animal Painting* (1891).

Land's End. See CORNWALL.

Landshut, a picturesque town of Upper Bavaria, on the Isar, 44 miles by rail N.E. of Munich. Of its eleven churches, St Martin's (1177) has a steeple 436 feet high. The castle of Trausnitz (*v.* 1232) was partially restored in 1872-74. Landshut has several breweries, manufactories of tobacco, wagons, hats, &c., and an active trade in corn. The Dominican monastery (1271) was the seat of the university, removed hither from Ingolstadt in 1800, and transferred to Munich in 1826. During the Thirty Years' War and the war

of the Austrian succession Landshut was several times captured; and here on 16th April 1809 the Austrians drove back the Bavarians, but were in turn defeated by Napoleon five days later. Pop. (1875) 14,780; (1885) 17,873. See works by Wiesend (1858-78) and Kaleher (1887).

Landsknecht. See FREE-LANCES.

Landskrona, a seaport of Sweden, stands on the Sound, 16 miles NNE. from Copenhagen. It has a good harbour, carries on sugar-refining, ship-building, and the manufacture of tobacco and leather, exports considerable corn and butter, and imports raw sugar, coal, and grain. Pop. (1875) 9084; (1888) 20,354. The town was a fortress down to 1870. Opposite Landskrona in the Sound lies the island of Ryen, on which Tycho Brahe built his observatory of Uranibourg.

Landslips, large portions of land which from some cause have become detached from their original position, and slid down to a lower level. They are especially common in volcanic districts, where the trembling of the earth that frequently accompanies the eruption of a volcano is sufficient to split off large portions of mountains, which slide down to the plains below. Water, however, is the chief agent in producing landslips. It operates in various ways. The most common method is when water insinuates itself into minute cracks, which are widened and deepened by its freezing in winter. When the fissure becomes sufficiently deep, on the melting of the ice a rock-fall or landslip is produced. Sometimes, when the strata are very much inclined, and rest on an impermeable bed like clay, the water which percolates down through the more porous rocks above softens the clay, which becomes slippery, whereupon the superincumbent mass slides over it to a lower level. This took place on a large scale in Dorsetshire between Lyme and Axminster in 1839, an unusually wet season; a mass of chalk and greensand here slid over the slippery surface of a bed of liassic clay down into the sea. Of a like kind were the slip of the Rossberg, in Switzerland, in 1806 (see GOLDIAT), and that which overwhelmed the village of Elm, in Glarus, in September 1881, when about 200 lives were lost. Another notable landslip was that of the Bocca di Brenta in south-west Tyrol in the year following; and at Zug in 1887 a landslip carried twenty-seven houses, with eleven persons, into the lake. Landslips of a different kind have been produced in peat-mosses, which, becoming by heavy rains thoroughly saturated with water, have burst their natural boundaries and discharged themselves on a lower level. The most remarkable case of this kind is that of the Solway Moss, which in 1772, owing to rains, spread itself in a deluge of black mud over 400 acres of cultivated fields. In 1880 a most destructive landslip occurred at Naini Tal, a health-resort on the southern slopes of the Himalayas. The town was partly built on a great sloping terrace of shaly deposit overhanging the lake, and this becoming saturated with the heavy autumn rains, it suddenly slipped forward, burying many houses in its debris. Forty Europeans and from 100 to 200 natives lost their lives. See GOO.

Land-surveying. See SURVEYING.

Landwehr ('Land-defence'), a military force in the German and Austrian empires, forming an army reserve, but not always retained under arms. Its members, although care is taken that they are sufficiently exercised, spend most of their time in civil pursuits during peace, and are called out for military service only in times of war or of commotion. (During the agrarian disturbances in Galicia in 1890 the Landwehr was employed for the first time against the peasant labour movement.)

The Prussian system of land defence was called into existence in 1813, when the Landwehr was organised according to Schamhorst's plan. At first it was designed solely as a land defence, properly so called, and not, what is now the case, as an integral part of the regular army. Every German capable of bearing arms, after serving in the standing army for seven years, now has to enter the Landwehr, and remain in it for other five years. In exceptional cases the Landwehr may be filled up from the *Landsturm*, which is not reckoned part of the army, and is called out only in the event of invasion; in both Germany and Austria it embraces men up to the age of forty-two (in Austria, for retired officers, till sixty). For the period of service in the Austrian Landwehr, see ARMY, Vol. I. p. 436.

Lane, EDWARD WILLIAM, the most eminent of English Arabic scholars, and the well-known translator of the *Arabian Nights*, was the son of the Rev. Theophilus Lane, LL.D., prebendary of Hereford, and his wife, Sophia Gardiner, a niece of Gainsborough the painter, and was born 17th September 1801. After education at the grammar-schools of Bath and Hereford, he began life, like his brother Richard (q.v.), as an engraver; but the need of a warmer climate took him to Egypt, and with that country the whole of his subsequent work was connected. The result of his first (1825-28) and second (1833-35) visits to Egypt was his *Manners and Customs of the Modern Egyptians* (1836; 5th ed. 1871), a work immediately recognised as of unrivalled accuracy and completeness, and still the standard authority on the subject. This was followed by the translation of the *Thousand and One Nights* (1838-40; 2d ed. 1859, and many reprints), which was the first accurate rendering of the tales, and (though necessarily abridged, on account of the objectionable nature of some of the incidents) is still the standard library edition. The numerous and instructive notes on Mohammedan life, literature, and superstition appended to the translation have been separately issued under the title of *Arabian Society in the Middle Ages* (1883). A volume of *Selections from the Koran* appeared in 1843 (2d ed. 1879). Lane's third visit to Egypt (1842-49) was devoted to laborious preparation for the great work of his life, the *Arabic Lexicon*, for which his extraordinary familiarity with the Arabic language and literature and his intimacy with the learned at Cairo peculiarly fitted him. The cost of this vast undertaking was borne by the fourth Duke of Northumberland and afterwards by his widow. Lane toiled without cessation for twenty years, with the zeal of a Sealiger, before he began printing, and then his first five quarto volumes came out (1863-74). The *Lexicon* was instantly accepted throughout Europe as the supreme authority. He died at Worthing, 10th August 1876, before completing it, but the publication of the remaining portions was carried on (1876-90) by his grand-nephew, S. Lane-Poole. In recognition of his unwearied devotion to learning he received a Civil List pension; the French Institute in 1864 elected him a correspondent; and he was made a Doctor of Literature at the telexentenary of the University of Leyden. See S. Lane-Poole, *Life of Edward William Lane* (1877).

Lane, RICHARD JAMES, engraver and lithographic artist, elder brother of the preceding, was born in 1800, and trained as an engraver by Charles Heath so successfully that at the age of twenty-seven he was chosen an A.R.A., partly on the strength of a fine engraving after Lawrence. Lithography, however, was just then coming in, and Lane abandoned engraving in favour of the

new art, in which 'he displayed a dignity and refinement of expression and an instinctive sympathy with his originals which have never been equalled.' His pencil was so delicate that his lithographs have often been mistaken at the first glance for line engravings. As a draughtsman in pencil or chalk he was very successful. In 1829 he executed an excellent profile of the Princess Victoria, then ten years of age, and he afterwards made portraits of most of the members of the royal family, and was appointed lithographer to the Queen and Prince Consort. His best lithographs (which number more than a thousand) include Lawrence's cycle of George IV., his own grand-uncle Gainsborough's sketches, and many works of Leslie, Landseer, and G. Richmond. He was also no mean sculptor, and attracted Chantrey's hearty admiration by such modelling as his life-size figure of his brother Edward. In his last years he directed the etching-class at the South Kensington Art Schools. He died 21st November 1872. See *Mag. of Art*, August 1881.

Lanercost, an Augustinian priory, founded about 1169, lies in the valley of the Irthing, 16 miles NE. of Carlisle. It is partly in ruins; but the nave has been restored and is now used as a parish church. The *Lanercost Chronicle, 1201-1246*, a valuable source for Border history, was really written, not at Lanercost, but at Carlisle. It was edited in 1839 by Joseph Stevenson for the Bannatyne and Maitland Clubs. Naworth Castle, 1 mile S. of the priory, is associated with the 'Belted Will Howard' of Scott's *Lay of the Last Minstrel*; it contains old armour, tapestry, &c. See R. S. Ferguson's *Lanercost* (1870).

Lanfranc, the first archbishop of Canterbury after the Norman Conquest, was born at Pavia about 1005, and educated at Pavia for the law. About 1039, however, he left Italy, and founded a school of law at Avranches, which soon became one of the most popular in France. Three years later he took the monastic vows at the Benedictine monastery of Bee, and in 1046 was chosen its prior. He figured prominently in the Berengarian controversy as to the real presence, ranging himself against Berengarins. About 1053 he came into close contact with William of Normandy. Although he at first condemned this prince's marriage with his cousin, he afterwards (1059) went personally to Rome to procure the papal dispensation for it. As a reward for this service William made him prior of his new foundation, the abbey of St Stephen at Caen (1062), and in 1070 promoted him to the primacy of England by making him Archbishop of Canterbury in place of the deposed Stigand. Lanfranc still continued to be William's trusty adviser, helping him both to fill the English sees with Normans and to make the royal power supreme above that of the church. He died in May 1089, leaving commentaries, sermons, letters, and a work against Berengar (ed. 1618 and 1844). See Hook's *Lives of the Archbishops*.

Lanfrey, PIERRE (1828-77), author, born at Chambrey, wrote on the church and the philosophers (1855), essays on the Revolution, and a history of the popes; but is best known for his famous (hostile) *Histoire de Napoléon I.* (1867-75; 8th ed. 1875; trans. 1872-80). He was successively moderate republican deputy, ambassador to Switzerland, and senator.

Lang, ANDREW, a remarkably versatile writer, was born at Selkirk, March 31, 1844, and was educated at Edinburgh Academy, St Andrews University, and Balliol College, Oxford. He took a classical first class, and was elected Fellow of Merton College in 1868. Ere long he plunged into the sea of literature, and soon became one

of the busiest as well as the brightest writers in the world of London journalism. He treats the most varied subjects with the same light, humorous touch, and he touches nothing which he does not adorn, although on serious themes he sometimes falls short of the seriousness that his reader has a right to expect. He has taken a foremost part in the controversy with Max Muller and his school about the interpretation of mythology and folk-tales, and it may safely be said that to his brilliant polemic have fallen most of the honours of the field. He was made LL.D. of St Andrews in 1885, and in 1888 was elected the first Gifford lecturer at that university. His chief books are *Ballads and Lyrics of Old France* (1872), *Ballades in Blue China* (1880), *Helena of Troy* (1882), *Rhymes a la Mode* (1884), *Grass of Parnassus* (1888), and *Ballads of Books* (1888), volumes of far more than merely graceful verse; *Custom and Myth* (1884), and *Myth, Ritual, and Religion* (2 vols. 1887), a solid contribution to the study of the philosophy and religion of primitive man, written with unusual directness and vigour, and lightened up by a wealth of felicitous illustration. Admirably clever and entertaining volumes, on subjects ranging from pure literature, as well as folklore and primitive religion, down to the by-ways of bibliographers and gossip of the day, are *The Library* (1881), *In the Wrong Paradise* (1886), *Books and Bookworm* (1886), *Letters to Dead Authors* (1886), *Letters on Literature* (1889), *Lost Leaders* (1889), *Old Friends: Essays in Epistolary Parody* (1890). He translated with exquisite skill *Aucassin and Nicolette* (1887), produced the faultless edition of Perault's *Popular Tales* (1888), and selected the fairy-tales forming the *Blue Fairy Book* (1889), the *New Fairy Book*, &c. He himself translated *Theocritus*, *Bion*, and *Moschus* (1880); and shared (with Butcher, Leaf, and Myers) in brilliant translations of the *Odyssey* and the *Iliad*. He was editor of the 'Abbotsford' Scott; wrote a history of *St Andrews* (1893), a novel, *The Monk of Fife* (1895), an edition of Burns's poems (1896), a *Life of Lockhart* (1896), *Pickle the Spy* (1897), and *Prince Charles Edward* (1900). He contributed BURNS and SCOTT to this Encyclopedia.

Lange, FRIEDRICH ALBERT, philosopher, was born at Wald, near Solingen, 28th September 1828, and died at Marburg, 23d November 1875. He wrote a most valuable *History of Materialism* (Eng. trans. by Thomas, 3 vols. 1878-81).

Lange, JOHANN PETER, theologian, born 10th April 1802, at Somborn, near Elberfeld, studied at Bonn, and after holding several pastoral charges became professor of Theology at Zurich in 1841, and in 1854 at Bonn, where he died, 9th July 1884. He wrote many works, of which the best known are a *Life of Jesus Christ* (1839; Eng. trans. by Marcus Dods), treatises on dogmatics (1849-52), Christian ethics (1878), hermeneutics, theological psychology, and his great *Bibelwerk*, a series of commentaries on the gospels (trans. into English), and, with other scholars, on the whole Old and New Testaments (also trans. into English).

Langeland (i.e. 'long land'), a low, fertile Danish island, 33 miles long by 5 broad, situated at the southern entrance to the Great Belt, between Funen and Lolland. Area, 106 sq. m.; pop. (1880) 19,900. Principal products—corn, flax, cattle, timber, fish. Chief town, Rudkjøbing (pop. 3179), on the west coast.

Langensalza, a town of the Prussian province of Saxony, 13 miles by rail N. by W. of Gotha, with a pop. of (1885) 10,924, and woollen and cloth manufactures. Here occurred, on 27th June 1866, an encounter between 19,000 Hanoverians and 8200 Prussians; the latter were at first defeated, but

being reinforced compelled the former to capitulate two days later. Not far from the town is a sulphur spring that attracts 600 visitors annually.

Langholm, a market-town of Dumfriesshire, at the junction of Ewes and Wauchope Waters with the Esk, 23 miles SSW. of Hawick, and 22 (by a branch-line) N. of Carlisle. Near the town hall is a marble statue of Admiral Sir Pulteney Malcolm (1768-1838), and on White Hill an obelisk to his brother, General Sir John Malcolm (1769-1833). Shepherd's plaid and tweeds have been manufactured since 1832. In 1890 Thomas Hope, a New York merchant and native of Langholm, left £80,000 to found a hospital here. Langholm is a burgh of barony (1643), under the Duke of Buccleuch, whose seat, Langholm Lodge, is close by. On the site of the town the Douglasses were defeated in the battle of Arkinholm (1455). Pop. (1831) 2264; (1881) 4209; (1891) 3643.

Langhorne, JOHN (1735-79), for a time rector of Blagdon in Somerset, devoted most of his life to literature, and published a long series of poems, tales, translations, &c. He is best known as having, with his brother William (1721-77), produced what has always ranked as the standard translation of Plutarch.

Langkat, or LANKHAT, a port on the east coast of the NW. part of Sumatra, near the borders of Acheen, is famed for its wells and shipments of petroleum.

Langland, or LANGLEY, WILLIAM, the supposed name of the author of *Piers the Plowman*, of whose life some few facts have been constructed from the internal evidence offered by the poem, mainly by the industry of Professor Skeat. He was born a franklin or freeman's son about 1332, probably at Cleobury Mortimer in Shropshire; went to school, possibly in the monastery at Great Malvern; became a clerk, but, having married early, could not take more than minor orders, and earned a poor living by singing the *placcho*, *dirige*, and 'seven psalms' for men's souls, and by copying legal documents. He lived many years in London, was named 'Long Will' from his stature, and prolonged poverty seems to have made him embittered and somewhat churlish in disposition. The last trace of him is in his poem of *Richard the Reddes* (850 lines), from which we learn that he was at Bristol in 1399.

The full title of his famous poem is *The Vision of William concerning Piers the Plowman, together with Vita de Do-wel, Do-bet, et Do-best secundum Wit et Resonum*. It exists in three different forms or recensions, distinguished by Professor Skeat as the A, B, and C texts. Of these the first was composed about 1362, and contains only 2567 lines. In it the Vision of Piers the Plowman is quite distinct from the Vision of Do-wel, Do-bet, and Do-best, the former consisting of a prologue and 8 passus (1833 lines), and the latter of a prologue and 3 passus (734 lines). The B text, the form of the poem which best represents the genius of the poet, was written after 1377, and contains about 7400 lines, consisting of the two Visions as before, the former arranged in a prologue and 7 passus, the latter in 3 prologues and 10 passus. The first part of the B text, giving the Vision of the Field full of Folk, of Holy Church, and of Lady Meed, next the Vision of the Seven Deadly Sins and of Piers the Plowman, was admirably edited by Professor Skeat as a school-book in the Clarendon Press series (1869). The C text was probably not composed till 1390. It adds about 250 lines to the poem, and is arranged, without prologues, continuously in 23 passus.

This long poem has great defects as a work of art, but the moral earnestness and energy of the author sometimes glow into really noble poetry,

particularly in his invectives against injustice and wrong, the idleness and pride of the clergy, and especially the dissolute habits of the mendicant friars. The theological discussions are not seldom tedious, but are brightened by vivid glimpses of the life of the poorer classes in his day, and some of the allegorical representations, as of the Glutton and Sloth, have something of the reality of life. The conception of the Plowman grows as the poem proceeds, and from a mere honest labourer he passes into a personification of the reforming spirit, and at one moment becomes identified with Christ himself. The writer is no precursor of Lollardism on its speculative side, or specially a Reformer other than in his revolt from the slavish hypocrisy of form apart from the inward power of religion, and his longing for a return to simple scripture truth without sacerdotal domination.

The metre of the poem is alliterative, but irregular. The dialect is mixed, but mainly Midland, with occasional introduction of Southern forms, and the vocabulary is of unusual extent.

The earlier editions of Robert Crowley (1505), Owen Rogers (1561), Dr Whitaker (the C text, 1813), and Thomas Wright (1842) were superseded by Professor Skeat's exhaustive and final edition for the Early English Text Society: Part I. (A text), 1867; Part II. (B text), 1869; Part III. (C text, with *Richard the Reddes*), 1873; Part IV., Notes, 1877; Glossary, &c., 1881. A more convenient edition of this was issued by the Clarendon Press in 1886 (2 vols.), the three parallel texts being printed together. See J. J. Jusserand, *La Poésie Mystique de William Langland* (1893).

Langres, a town in the French department of Haute-Marne, is situated at an elevation of 1530 feet above sea-level (one of the highest towns in France), 184 miles ESE. of Paris by rail. A place of military importance as key of the communication between the Seine and the Rhone, it has been strongly fortified since 1868, and has a cathedral of the 12th and 13th century. Pop. 7157. Langres (anc. *Audenotianum*) in Caesar's time was the capital of the Lingones, a name corrupted into Langres.

Langside, a southern suburb of Glasgow, with a pop. of 6023. Here, after her escape from Loch Loven, Queen Mary's forces were totally defeated by the Regent Moray, 13th May 1568. A monument (1887) commemorates the battle.

Langson, a town in Tongking, situated north-east of Ha-noi, near the frontier of the Chinese province of Kwang si. It was a centre of operations in the Franco-Chinese war of 1884-85.

Langton, STEPHEN, famous in the history of the liberties of England, was born about 1150, but where is uncertain, Lincolnshire, Yorkshire, and Devonshire all claiming him. He received his education in the university of Paris, where he was the fellow student and friend of the future Pope Innocent III.; he rose to the office of chancellor of the university. Innocent after his elevation gave Langton a post in his household, and afterwards made him a cardinal (1206). On occasion of the disputed election to the see of Canterbury in 1205-7 Langton was recommended by the pope to those electors who had come to Rome on the appeal, and, having been elected, was consecrated by Innocent himself at Viterbo, June 27, 1207. His appointment was resisted by King John (q.v.); and for six years Langton was kept out of the see, only being admitted when John made terms with Innocent in 1213. In the conflict of John with his barons Langton was a warm partisan of the latter, and his name is the first of the subscribing witnesses of Magna Charta. And, although the pope excommunicated the barons, Langton refused to publish the excommunication, and was in consequence suspended from his func-

tions by the pope in 1215. But after the accession of Henry III. he was reinstated (1218) in his see, and from that time chiefly occupied himself with church reforms till his death, which took place July 9, 1228. See Dr Hook's *Lives of the Archbishops of Canterbury*, vol. ii. (1861).

Language. See PHONOLOGY; and UNIVERSAL LANGUAGE, VOICE, LETTERS.

Languedoc, a former province of the south of France, bounded on the E. by the river Rhone, on the S. by the Mediterranean and the counties of Foix and Roussillon, and on the W. by Gascony and Guienne. It is now embraced in the departments of Lozère, Gard, Ardèche, Aude, Hérault, Upper Loire, Tarn, and Upper Garonne. The name is derived from *langue d'oc*, the southern French dialect, or Provençal (q.v.), so called because the people used *oc* instead of *oui* for 'yes,' as in the northern provinces. During the period of the Roman empire this part of Gaul was prosperous and wealthy, a home of enlightenment. In 412 the Visigoths founded the kingdom of Toulouse (one of the chief cities of Languedoc, Montpellier being the other), and were only overthrown in 759 by Pepin the Frank. Two centuries later this part of France was immediately subject to the count of Toulouse, one of the great feudatories of the kingdom. The story of the religious wars of the 12th and 13th centuries has been already recounted under ALBIGENSES (q.v.). For the Languedoc Canal, see CANAL.

Lanida. See BUTCHER-BIRD.

Lankâvatâra, one of the chief religious works of the Buddhists, which treats of their religious law, and of some of their most abstruse philosophical problems.

Lankester, EDWIN RAY, zoologist, was the son of Dr Edwin Lankester (1814-74), scientific writer, and was born in London, 15th May 1847. Educated at St Paul's School and at Christ Church, Oxford, he was fellow and tutor of Exeter College, and in 1872 became professor of Zoology and Comparative Anatomy in University College, London. He is F.R.S. and LL.D. Among over a hundred scientific publications by him are memoirs on 'Fossil Fishes of the Old Red Sandstone' in the *Philosophical Transactions*, and works on *Comparative Longevity* (1871), on *Depravation* (1880), and on *Advancement of Science* (1890).

Lammer. See FALCON.

Lannes, JEAN, DUKE OF MONTEBELLO, a French marshal, was born, the son of a livery-stables keeper, on 11th April 1769, at Lectoure (Gers), entered the army in 1792, and by his conspicuous bravery in most of the battles of the Italian campaign fought his way up to be general of brigade by 1796. He rendered Napoleon important service on the 18th Brumaire. On 9th June 1800 he won the battle of Montebello, whence his title, and bore a principal share in the battle of Marengo. He commanded the left wing at Ansterlitz, and the centre at Jena, and distinguished himself at Eylau and Friedland. Being sent to Spain, he defeated General Castaños at Tudela, 22d November 1808, and took Saragossa. In 1809 he again served on the Danube, and commanded the centre at Aspern (22d May), where he had both his legs taken off by a cannon-shot. He was carried to Vienna, and died there, 31st May. He was interred, first in the Pantheon, afterwards in Pere-la-Chaise, in Paris.

Lannion, a town in the French department of Côtes du-Nord, on the Gner (which is navigable for sea-going ships to this point), 69 miles by rail E.N.E. of Brest. Pop. 5893.

Lansdown, a hill (813 feet) to the north of Bath, commanding a prospect of exceptional beauty. Here stands a tower of 130 feet, built by Beckford, and two miles beyond was fought the battle of Lansdown, 5th July 1643, when Waller's entrenchments were stormed by the Cornish royalists. On the spot where the heroic Sir Bevil Grenville fell Lord Lansdowne raised a monument in 1723.

Lansdowne, HENRY PETTY FITZMAURICE, third MARQUIS OF, was the son of the first marquis, better known as the Earl of Shelburne (q.v.), and was born in London, July 2, 1780. He received his education at Westminster School, Edinburgh University, and Trinity College, Cambridge, where he graduated in 1801. Born in the purple of politics, he was returned for the burgh of Calne at the age of twenty-two. He ranked himself among the opponents of Pitt, and took a leading part in that attack on Lord Melville which brought home to him the charge of corruption. When Pitt died Lord Henry Petty—as he was then styled—succeeded him as member for Cambridge University, and also as Chancellor of the Exchequer in the administration of 'All the Talents' formed by Lord Grenville, but held office for about a year only. In 1809, and after having represented the borough of Camelford for a short time, he succeeded by the death of his half brother to the marquise of Lansdowne. A sincere though cautious Liberal, he in 1826 entered the Canning cabinet; and in the short Goderich administration he presided at the Foreign Office. When, in 1830, the Whigs came into power under Lord Grey, Lansdowne became President of the Council, and took an active part in the passing of the Reform Bill of 1832. He held this office, with a short interval, till September 1841. Five years later, under Lord John Russell, he resumed his post, taking with it the leadership of the House of Lords, and held it till 1852. In that year he was requested to form an administration, but consented to serve without office in the coalition cabinet of Lord Aberdeen. When that ministry fell in 1855, Lansdowne was again asked to accept the premiership, but he once more declined, although he consented to help Lord Palmerston as he had helped Lord Aberdeen. He refused a dukedom. After the death of the Duke of Wellington Lansdowne was recognised as the patriarch of the House of Peers, while almost up to his death his advice was asked at his seat of Bowood by the leaders of the Liberal party. He was the attached personal friend of the Queen. Fond of literature and of the company of men of letters, he formed a great library, and one of the best collections of pictures and statuary in the kingdom. He died January 31, 1863.

The political biographies of the period in which Lansdowne lived abound in references to him. A considerable number of his letters on public affairs appear in *Lord Melbourne's Papers*, edited by Lloyd C. Sanders (1889). *The Life of Lord John Russell*, by Spencer Walpole (1889), illustrates in a remarkable manner the quiet but great influence exerted by Lansdowne in the councils of his party.

Lansdowne, HENRY CHARLES KEITH PETTY FITZMAURICE, fifth MARQUIS OF, was born January 14, 1845. Educated at Eton and Balliol College, Oxford, he succeeded to the marquise in 1866, and, attaching himself to the Liberal party, was a Commissioner of Exchequer of Great Britain and of Treasury of Ireland from 1868 to 1872. Between 1872 and 1874 he was Under secretary for War. In 1880 he again took office under Mr Gladstone as Under-secretary for India, but resigned owing to a difference with his chief over the Compensation for Disturbance (Ireland) Bill. In 1883 he was appointed Governor general of the Dominion of

Canada, in 1888 Governor-general of India, in 1895 Secretary for War, and in 1900 Foreign Secretary. See a book by G. W. Forrest on his Indian administration (1894).

Lansing, the capital of Michigan, on both sides of the Grand River, 85 miles WNW. of Detroit, at the meeting-point of four railroads. It contains the state capitol, library, reform school, and agricultural college, a school for the blind, and several manufactories. Lansing was settled and made the state capital in 1817, and incorporated as a city in 1859. Pop. (1870) 5241; (1890) 13,102.

Lansingburg, a town of New York, on the Hudson, 10 miles above Albany. It contains an Augustinian priory, and has extensive manufactures of brushes and oil-cloth. Pop. 10,550.

Lantern, in Architecture, an ornamental structure raised over domes, roofs, &c., to give light and ventilation. The dome of St Paul's Cathedral and many other large domes are crowned with a lantern. Where a lantern is for the purpose of giving light it is called a *lantern-light*. In Gothic architecture a *lantern-tower* is frequently placed over the centre of cross churches—the vault being at a considerable height, and the light admitted by windows in the sides. York and Ely cathedrals, and many churches in England, have such lantern-towers.

Lantern-fly (*Fulgura*), a genus of Hemiptera, type of a family Fulgoridae, allied to Cicadidae, but with legs more adapted for leaping, and without organs for producing sound. There are about a score of species, all tropical, most from South America, the rest in Asia and Africa. The forehead bears a remarkable empty dilatation or 'lantern,' quaint in form, sometimes towards an inch

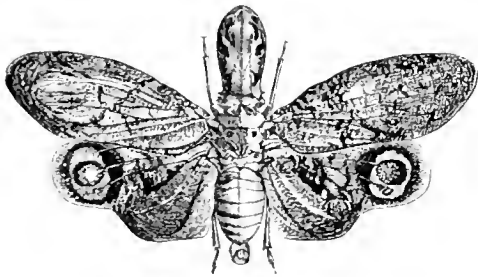

Lantern-fly (*Fulgura leucocentria*).

in length. The name lantern-fly was originally given to *F. leucocentria*, a species found in Guinea, measuring about 3 inches in length. The inflated projection of the forehead is said by some to be at times very brilliantly luminous; but the evidence is contradictory, and most naturalists refuse to believe in the luminosity of any of the species. It is possible that the luminosity, if genuine, is only occasional and of sexual significance. In the Chinese Lantern-fly (*F. cambelaria*) the prolongation of the forehead is comparatively narrow.

Lanthanum (sym. La, equiv. E39), so named from the Greek *lanthano*, 'to be hid,' is a metal which was discovered by Mosander in 1839 in *Cerite*, a hydrated silicate of Cerium (q.v.). It is of little chemical interest, and is of no practical value. See DIDYMIUM.

Lanzi, LUIGI, Italian antiquary, was born at Monte dell' Olmo, near Macerata, June 14, 1732. He entered the order of the Jesuits, but devoted his time to the study of classical antiquities and of Italian painting. He resided chiefly at Florence, where he died, March 30, 1810, and was buried by the side of Michael Angelo in the church of Santa

Croce. The principal monuments of his learning are the works *Saggio di Lingua Etrusca* (3 vols., 1789), in which he insisted upon the kinship of Etruscan with Latin, Oscan, Umbrian, and Greek; and *Storia Pittorica d'Italia* (1792-1806; Eng. trans. by Thomas Roscoe, 6 vols., 1828). Lanzi also wrote works on Etruscan vases, antique sculptures, &c. His posthumous works were published in 2 vols. at Florence in 1817. See Life in Italian by Cappi (1810).

Laocöon, according to classic legend, a priest of Apollo, afterwards of Poseidon, in Troy, who married against the will of the former god, and who warned his countrymen against admitting the wooden horse into Troy. For one or both of these reasons he was destroyed along

with his two sons by two enormous serpents which came up out of the sea. This legend is not Homeric, but of later origin. It was a favourite theme of the Greek poets, and is introduced in the *Æneid* (ii.) of Virgil. The subject is represented in one of the most famous works of ancient sculpture still in existence, a group discovered in 1506 at Rome, on the side of the Esquiline Hill, and purchased by Pope Julius II. for the Vatican. It was carried by Bonaparte to Paris in 1796, but recovered in 1814.



Laocöon.

The whole treatment of the subject, the anatomical accuracy of the figures, and the representation both of bodily pain and of passion, have always commanded the highest admiration. According to Pliny, it was the work of the Rhodian artists, Agesander, Polydorus, and Athenodorus; various dates have been assigned to it, from 200 B.C. till 200 A.D.; but the best authorities place its date at a little before 100 B.C. For an admirable æsthetic exposition of its merits, see Lessing's *Laocöon* (1766; new ed. with bibliography by Blümner, 1889; Eng. trans. 1836, 1853). There is a recent German Monograph by Kekulé (1883).

Laodamia, in Greek heroic history, the daughter of Acastus and wife of Protesilaus. Her husband was the first of all the Greeks who fell by a Trojan hand, being killed as he leaped on shore from his ship. Laodamia prayed the gods to give him back to her for but three hours. Her prayer was granted; Hermes led him back to the upper world; and, when the fatal moment to return had come, Laodamia died with him. This noble story has been treated by Wordsworth in verse worthy of the theme.

Laodicea, a name given to several cities—eight at least can be distinguished—founded or rebuilt by the Seleucid rulers of Syria; it is adapted from Laodice, a favourite name for the female relatives of these sovereigns. Of the cities so called, the most famous and most interesting was situated 2 miles from the banks of the river Lycus in Phrygia, and on the great commercial road leading from the Ionian cities to the Euphrates. The district in which it stands has frequently suffered from earthquakes, and the city was more than once in part overthrown by them. It finally began to decay at the period of the Ottoman invasions,

and is now a heap of uninteresting ruins, known as Eski-Hissar. Art and science flourished among the ancient Laodiceans; it was the seat of a renowned medical school, produced some famous philosophers, and in its mint was struck a valuable series of coins, which come down to the time of Diocletian. But its greatest importance is due to the fact that it was one of the chief homes of early Christianity, designated one of the seven churches of the Apocalypse, but doomed to unhappy memory as 'lukewarm and neither cold nor hot' (Rev. iii. 16). Probably the fact is traceable to the settlement here of great numbers of Jews at that period. The important ecclesiastical council of Laodicea, held here in 363, adopted resolutions concerning the canon of the Old and New Testaments, and concerning ecclesiastical discipline. A second council, held here in 476, condemned the Eutychians.—Another of these cities Laodicea will be found described under Latakia (q.v.).

Laomedon, king of Troy (q.v.), and father of Priam.

Laon, chief town of the French department of Aisne, is situated on a steep isolated hill (594 feet), 87 miles by rail N.E. of Paris. Occupying a naturally strong position, it has been a fortress since the 5th century; its citadel is surrounded with ruinous walls. From 515 to 1790 it was the seat of a bishop. The cathedral, a Gothic edifice of the 12th century with a handsome facade, and the bishop's palace, now used as a law court, still remain. The inhabitants are noted market-gardeners, producing excellent artichokes and asparagus. In the 10th century the city was the place of residence of the Carolingian kings, and capital of *Francia*. At Laon, on March 9 and 10, 1814, Napoleon I. was repulsed by the allies under Blücher and Bulow; and it surrendered to a German force on 9th September 1870, when the explosion of the powder-magazine by a French soldier cost some 500 lives. Pop. (1872) 10,243; (1891) 13,959.

Laos. See SHANS.

Láo-tsze, a celebrated philosopher of China, generally reputed to have been the founder of Taoism, which at the present day shares the allegiance of the Chinese with Confucianism and Buddhism under the appellation of San Chiáo, 'the three doctrines' or 'teachings.'

According to the most likely account, Láo's birth took place in 604 B.C., fifty four years before that of Confucius. His surname was La (meaning 'Plum'), and his name Erh (meaning 'Ear'), which after his death gave place to Fan, denoting some peculiarity in the form of his ears. He comes before us as a curator of the royal library in the capital city of Loh, not far from the present city of Loh yang in Ho-nan. The designation Láo tsze means the 'old philosopher.' The two Chinese characters may also be translated 'the old son or boy;' and the legendary writers have taken occasion from this to relate that the child was carried in his mother's womb for seventy-eight, some say for eighty-one, years, and that he was born with the white hair of an old man. Confucius and Lao seem to have met several times. One interview at the capital in 517 B.C. is pretty well established. It was not entirely amicable, but left a strong impression on the mind of Confucius. He said at the close of it to his disciples, 'To day I have seen the Old Philosopher (Láo tsze), and can only liken him to the dragon who mounts aloft on the clouds, I cannot tell how, and rises to heaven.' So it was that Li Erh came to be denominated 'Láo tsze.' Nothing certain can be said of the length of Láo's life. Sze-ma Ch'ien, the historian of ancient China, tells us that he cultivated 'the Táo and its characteristics,'

his chief aim being to keep himself unknown; that he resided long at the capital, and then seeing the decay of the dynasty of Chau, went away to the gate which led out of the royal domain towards the regions of the north-west; that there he was recognised by Yin Hsi, the keeper of the gate, the place of which is shown in the present Shan Chau of Ho-nan, and was prevailed upon to write out for him the treatise called the *Táo Teh King*, which has come down to us as the only record of his teaching. Ch'ien adds that after giving this writing to the keeper 'he went away, and it is not known where he died.' Such is the substance of all of importance which the great historian, writing in the 2d century B.C., could tell of Láo-tsze. He says nothing of the pre-existences attributed to him, nor of his subsequent travels in the west, where he became acquainted with the wisdom of India and even Judea. These and other marvels are later and fabulous additions to Ch'ien's brief account, and arose in imitation of the legends of Buddhism and through misconceptions of the meaning of the *Táo Teh King*.

Some doctrine of the Táo had come down from the most ancient times, and a father, or at least a most important teacher, of it is claimed in Hwang Ti, the mythical sovereign of the 27th century B.C. It served especially as a discipline adapted to promote longevity and to preserve life. Láo-tsze entered into this, and the doctrine assumed in his hands a more subtle character. It is not easy, however, to say what he meant by his Táo. 'It was the originator of heaven and earth; it is the mother of all things.' At the same time it is not a personal being. 'It might appear,' he says, 'to have been before God.' 'It gave,' says Chwang-tsze, the ablest of all Lao's followers, 'their mysterious existence to spirits and to God (or to gods).' The character Táo properly means 'path,' 'course,' or 'way;' and it is in this sense that Lao uses it. His 'great way' is but a metaphorical expression for the way in which things came at first into being out of the primal nothingness, and how the phenomena of nature continue to go on, in stillness and quietness, without striving or crying. Of the same kind should be the influence of the Táo in the conduct of individuals and of government. That things may come to the right and successful issue they must be carried on without effort or purpose. The secret of good government is to let men alone. The appeal to arms is hateful. All learning is injurious. The wisdom of men defeats its own ends. 'Táo works by contraries, and the secret of its strength is its weakness. In many of these teachings Láo-tsze may seem to be only a visionary dreamer, but he enunciates many lessons of a very high morality. Its fundamental quality is humility, which he compares again and again to water, soft and weak in itself, yet able to attack and overthrow the strongest and firmest things. With humility he associates gentleness and economy, and calls them his 'three precious possessions.' He even rises to the greatest of all moral principles, the returning of good for evil, and enunciates 'recompensing injury with kindness.' He nowhere speaks clearly of the state of man after death; but Chwang tsze teaches that life and death follow each other in endless succession, or like the sequence of the four seasons. There is nothing about religion or religious worship in the *Táo Teh King*. The origin of Taoism as a religion cannot be placed earlier than our 1st century. It was not till after Buddhism found its way to China that the other system began to have images, temples, monasteries, and nunneries. The pursuits of alchemy, communications with spirits, concoctions of the *elixir vita* and pills of immortality are among the phases which it has assumed at different times; but such things have no connection with the teaching of Láo tsze.

See Stanislas Julien, *Le Livre de la Vou et de la Vertu* (1842); Chalmers, *The Speculations of the Old Philosopher* (1848); F. von Strauss, *Lao-tse's Tao Tê King* (1870); R. von Planckner, *Lao-tse, Tao Tê King, Der Weg zur Tugend* (1870); Douglas, *Confucianism and Taoism* (1879); Legge, *Religions of China* (1880); Bal-four, *Taoist Texts* (1881); and CHINA, Vol. III, p. 190.

La Paz. (1) A department of Bolivia, bordering on Peru, with an area of 171,200 sq. m., and a pop. (1895) of 595,000, not including some 2500 wild Indians. The La Paz cordillera contains the loftiest peaks of the Bolivian Andes, and much of the surface of the department is a dry plateau; but in the east the great mountains sink to the plain, and the country is richly watered.—The capital, La Paz, lies at the foot of a steep valley 11,952 feet above the sea, 42 miles SE. of Lake Titicaca. It has a handsome but unfinished cathedral, and a college, seminary, and medical school; but the houses are mostly of mud, and owing to the extremely uneven site present a very irregular appearance. The inhabitants, mostly Indians and half-breeds, carry on an active trade in copper, alpaca-wool, cinchona, &c. Pop. (1889) 57,000.—(2) A town of Entre Rios province, in Argentina, on the Paraná, 530 miles by river N. by W. of Buenos Ayres. Pop. 6800.

La Pérouse. JEAN FRANÇOIS DE GALAUP, COMTE DE, a French navigator, was born near Albi, in Languedoc, on 22d August 1741. He distinguished himself in the naval war against England (1778-83), especially by destroying the forts of the Hudson Bay Company. Two years after the conclusion of peace he was chosen to command an expedition of discovery sent out by the French government. He sailed in August 1785 with two ships, visited the north-west coast of America, explored the north-eastern coasts of Asia, where by sailing through La Pérouse Strait between Saghalien and Yezo he discovered that each of these was a separate island. In February 1788 he sailed from Botany Bay; after that all trace of him was lost. In 1826 it was fully ascertained by the English Captain Dillon that both of La Pérouse's ships had been wrecked in a storm on a coral-reef off Vanikoro, an island lying north of the New Hebrides. The account of the early portions of La Pérouse's voyage, prepared from journals sent home by him, was published under the title of *Voyage autour du Monde* (4 vols. Paris, 1797; new ed. in 1 vol. 1888).

Lapis Lazuli (Lat., 'azure stone,' the *lazuli* being for Arabic *lazward*, the name of the stone; *azur* is a corruption of *lazward*), a mineral of beautiful ultramarine or azure colour, consisting chiefly of silica and alumina, with a little sulphuric acid, soda, and lime. The colour varies much in its degree of intensity. Lapis lazuli is often marked by white spots and bands. It is generally found massive, and is translucent at the edges, with uneven, finely granular fracture, but sometimes appears crystallised in rhombic dodecahedrons, its primitive form. It is found associated with crystalline limestone amongst schistose rocks and in granite, in Siberia, China, Tibet, Chili, &c. The finest specimens are brought from Bokhara. It seems to have been the only stone of any intrinsic value known to the Egyptians under the Pharaohs. The ancients used it much for engraving, for vases, &c. (see King's *Natural History of Gems*). It is extensively employed in ornamental and mosaic work, and for sumptuous altars and shrines. It is easily wrought, and takes a good polish. The valuable pigment called Ultramarine (q.v.) is made from it. It is one of the minerals sometimes called *Azure Stone*.

Lapithæ. a mythical race inhabiting the mountains of Thessaly. They were ruled by Pirithous,

a son of Ixion and half-brother of the Centaurs. At the marriage of Pirithous to Hippodamia, the Centaurs, flown with insolence and wine, attempted to carry off the bride and the other women, but were overpowered after a bloody struggle by the Lapithæ.

Laplace. PIERRE SIMON, MARQUIS DE, the greatest mathematician and theoretical astronomer since Sir Isaac Newton, born 28th March 1749, was the son of a poor farmer at Beaumont near Trouville, in Normandy. He studied at Caen, through the assistance of some charitable neighbours, and, after teaching mathematics at a military school in his native town, went to Paris and attracted the notice of D'Alembert by a paper on dynamics. When appointed professor in the Royal Military School he soon acquired a reputation by his mastery of the whole range of mathematical science and its application to certain difficulties in practical astronomy—solving a problem which both Euler and Lagrange had grappled with in vain. Chosen an associate of the Academy of Sciences in 1773 and member in 1785, he meanwhile, by his powerful grasp of the analytic method of dealing with gravitating masses, established the great generalisation that our planetary system is stable—that what had been termed irregularities were not disturbing the general equilibrium, but, on the contrary, necessary to it. This complete solution of the 'mechanical problem of the solar system,' as he termed it, has bestowed upon astronomy the 'Three Laws of Laplace.' Here, as well as in his great treatise to be presently mentioned, the special service of Laplace was that he set forth comprehensively in one homogeneous work the leading results which had severally been attained by Newton, Halley, Clairaut, and Euler, at the same time proving their harmony and interdependence. The singular insight of Laplace as an astronomer was apparent in his explanation of the 'secular inequalities' shown by ancient and modern observations in the motions of the planets Jupiter and Saturn. He was the first to construct a complete theory of the satellites of Jupiter, and his investigation of the tidal theory has been characterised by Airy as 'one of the most splendid works' in the history of mathematics.

The successive governments of France agreed in honouring Laplace. He helped to establish the Polytechnic and Normal Schools in Paris, became one of the first members of the Bureau des Longitudes, and soon after was appointed president. After the 18th Brumaire Bonaparte made Laplace Minister of the Interior, though only to supersede him in six weeks' time. In 1799 Laplace entered the senate, where he made a report on the necessity of returning from the Revolution calendar to the Gregorian; in 1803 he was appointed chancellor of the senate. He was created count under the empire, and in 1815 a peer, in 1817 a marquis, by Louis XVIII. His opponents attributed the latter honour to his having voted for the deposition of Napoleon in 1814, accusing him of servility, which was also alleged in 1827 when he became an 'ultra royalist.' Elected to the Academy in 1816, he was next year appointed president. In his memoir on the 'attraction of spheroids' are first set forth the two celebrated means of applying analysis to physical problems—Laplace's coefficients and the potential function—which are requisite in the theory of attractions and in the more abstruse parts of electrical science.

Besides many original treatises on the application of mathematical methods to lunar and planetary problems, molecular physics, electricity, and magnetism—mostly memoirs to the French academies—Laplace published the four following books. *The Mécanique Céleste*, with supplements (5 vols. Paris, 1799-1825), stands alone amongst works on mathe-

mathematical astronomy as a systematic demonstration of the highest results in natural philosophy. The *Exposition du Systeme du Monde* (1796; 6th ed. 1824) was written for non-mathematicians, and has been admired for the excellent style as well as for its clear and concise statement of all the leading astronomical facts and theories. In a note at the end of the later editions occurs the famous Nebular Hypothesis (see NEBULE), which many have deemed to be of not less importance than many of the results obtained by great mathematic effort. As early as 1784 Laplace issued his *Theorie du Mouvement et de la Figure des Planetes*, and in 1812-14-20 his *Theorie analytique des Probabilites*. The last remains a classic work to algebraists, though extremely difficult, the theory being applied not only to ordinary chances and averages, but to causes of phenomena and vital statistics.

Laplace was gifted with great power of memory and keen scientific sagacity, as well as with singular skill in interpreting nature by means of the higher mathematics. He showed some personal vanity, but was of an amiable disposition, frequently assisting young men of promising parts. His constant good health was partly attributable to his abstemiousness. Laplace died at Paris, 5th March 1827. In 1878 the Academy undertook a 13-vol. edition of his *Œuvres complètes*.

Lapland is neither a political nor a geographical unity; it is simply the collective name for the extensive region in the north of Europe that is inhabited by the Lapps. On the N. it is bounded by the Arctic Ocean, on the NW. by the Atlantic, on the E. by the White Sea; its southern limits coincide, roughly speaking, with 66° N. lat., though Lapps are sometimes found as far south as 63° N. lat. in Norway and Sweden. Norwegian Lapland is of course a mountainous country, its coasts cleft by the narrow, steep-walled fjords. In Swedish Lapland the most characteristic features are ridges with narrow valleys between, the latter generally partly filled with long, narrow lakes. Farther east, in Finnish and Russian Lapland, the surface is more level, the rivers and lakes become more numerous, marshes are frequent, and next the Arctic Ocean barren tundras; and many square miles are covered with forests of fir and spruce. Yet low ranges of hills occur in some districts, as, for instance, the Umebek Mountains, in the peninsula of Kola. Some of the lakes are of large size; Lake Enare or Inara, in Finnish Lapland, has an area of 1147 sq. m.; Lake Inuandja is 65 miles long by 9 wide; and Lake Nnot, 35 miles long by 7 wide. The river Tana, which flows north to the Arctic Sea, is the second longest river of Norway; and several other rivers of considerable size flow into the White Sea and the Gulf of Bothnia, as the Tulom, the Kemi, &c. The summer is short and comparatively hot, owing to the fact that the sun scarcely ever sinks below the horizon during the three months that summer lasts. During this period the mosquitoes are a terrible plague. For seven or eight weeks in winter the sun does not rise above the horizon; comparative darkness prevails all the time, except when the snow-covered landscape is illuminated by the weird conceptions of the aurora borealis. The cold in winter is excessive, the thermometer generally indicating sixty degrees of frost, and sometimes more; but owing to the prevalent stillness of the air the cold is not felt so severely as might be expected. The total Lapp population is about 28,000, thus distributed: 18,000 in Norway, 7000 in Sweden, nearly 800 in Finland, and 2000 in Russia. But there are also numerous settlers belonging to these four nationalities in Lapland, chiefly engaged in agriculture, hunting, trading, and in administrative work, some of them no doubt

the descendants of the criminals transported thither from Denmark three centuries ago.

The Lapps, who call themselves Sabme or Sabme-ladsjak (the Norwegians call them Finns, whilst the Finns they call Kvæns or Qvæns), belong to the Ural-Altaic stock, and are consequently closely related to the Finns (Suomi). As a race they are the shortest people in Europe (4 or 5 feet in height), and the most brachycephalic. In other respects they are spare of body, with dark, bristly hair and scanty beard, and short, often bandy, legs. Although not very muscular they are capable of great exertion and fatigue, and frequently live to a great age (eighty or more). The mouth is large, the lips thick, and the eyes small and piercing, but not obliquely set. The Lapps are usually distinguished as Mountain, Sea, Forest, and River Lapps. The Mountain Lapps, the backbone of the race, are nomads; they move constantly from place to place in order to find sustenance (Arctic moss) for their reindeer herds, their only source of wealth. In summer they go down to the fjords and coasts, but spend the rest of the year in the mountains and on the plains of the interior. The Sea Lapps, mostly impoverished Mountain Lapps, or their descendants, dwell in scattered hamlets along the coast, and live by fishing. The Forest and River Lapps are nomads who have taken to a settled mode of life; they not only keep domesticated reindeer, but hunt and fish. The nomad Lapps live all the year round in tents. The reindeer supplies nearly all their wants, except coffee, tobacco, and sugar. They live on its flesh and milk; they clothe themselves in its skin; and use it as a beast of burden. In winter, harnessed to a boat-shaped sledge (*putk*), it takes them the longest journeys, across frozen lakes and rivers, and over the mountains, and through the forests. It is computed that there are 400,000 reindeer in Lapland, for the most part semi-wild. In his personal habits and in his clothing the Lapp is the reverse of cleanly. He is, however, very good-natured, rather prone to self-indulgence when the opportunity presents itself (which is not often), but at other times sober enough. As a rule, he is 'saving, almost miserly,' selfish and 'cute in all his dealings,' not very trustworthy in the matter of speaking the truth, but on the whole inclined to take life easily. His imagination is easily excited, and he is readily susceptible to religious impressions of a sensational type; a notable 'epidemic' occurred at Koutokemo in Norwegian Lapland in 1848-51. The Lapps all profess Christianity; those of Norway and Sweden belong to the Lutheran Church, those of Russia to the Greek Church. Lapland witches, who are, more correctly speaking, wizards, have been famous from very early times. The principal instrument of divination was a curious oval-shaped drum, covered with a variety of figures and signs. In very early times the Lapps probably came much farther south in both Scandinavia and Russia; the bones of men of a short race, identified with the Lapps, have been discovered in several ancient Scandinavian burial mounds. The Norsemen treated the Lapps as a subject race as early as the 9th century, but had to reconquer them in the 14th; the Russians followed suit in the 11th, and the Swedes in the 16th. From the 13th to the 17th century the Lapps were kept in a state little better than slavery by Swedish adventurers known as Birkaadians. But at the present day both the Scandinavian governments bestow upon them every kindness.

See Sir Arthur de Capell Brooke, *A Winter in Lapland* (1827); Læstadius, *Journal* (1831); Tronholt, *Under the Rays of the Aurora Borealis* (2 vols. 1885); Du Chailly, *The Land of the Midnight Sun* (2 vols. 1881); Rae, *White Sea Peninsula* (1882) and *Land of the North*

Wind (1875); Lieutenant Temple in *Proc. Roy. Geog. Soc.* (1880); Leem, *An Account of the Laplanders of Finmark* (Pinker's *Voyages*); and David MacRitchie, *The Testimony of Tradition* (1890). For folklore, see also Fris, *Lappisk Mythologi*, &c. (1871); Donner, *Lieder der Lappen* (1876); and Poestion, *Lappplandische Marchen*, &c. (1885). Many Lapp and Finnish parallels are given in Jones and Kropf's *Magyar Folk-tales* (1889).

La Plata, the capital of the Argentinian province of Buenos Ayres, was founded in 1882, after Buenos Ayres city, from which it is about 30 miles S.E., had been made the federal capital. The new city was rapidly built, with wide streets, that are now mostly paved, and over a score of open squares; the central portion is lit with the electric light, the rest with kerosene lamps, and there is a service of tramways. The only buildings of note are the handsome capitol and other offices of the government, an observatory, several chapels, and a fine railway station. There are scores of hotels, inns, and cafes. The city has a college, and, 7 miles away, a hospital and an asylum for the insane. Among the manufactories already established is one of cotton and woollen tissues. A canal connects a harbour which has been constructed at La Plata with a larger outer harbour at Ensenada, on the La Plata River. Pop. (1888) of municipality (including, however, Ensenada and a country district of nearly 60 sq. m.), 50,803.

La Plata, Rto DE, a wide estuary of South America, between Uruguay on the north and the Argentine Republic on the south, through which the waters of the Parana and the Uruguay sweep down to the ocean. It is about 200 miles long, 28 wide at Buenos Ayres, and 140 miles broad at its mouth, between Maldonado and Cape San Antonio. The northern shore is somewhat steep and lofty, but that along the province of Buenos Ayres is low and flat, with wide sandbanks that prevent ships from approaching closely to the shore. The estuary has thus no shelter from the tempestuous storms that come from the south-west; and even the only good harbour, that at Montevideo, is open to the south-east. The affluents of the La Plata drain an area estimated at 1,600,000 sq. m., and the outflow of the estuary is calculated at about 52,000,000 cubic feet per minute—a volume exceeded only by that of the Amazons; the yellow, muddy stream is recognisable 60 miles out at sea. For the navigation of the affluents, see PARAGUAY, PARANA, and URUGUAY. The estuary was discovered in 1515 or 1516 by Diaz de Solis, who was shortly afterwards roasted and eaten by the Indians on its bank. See Sir Horace Rumbold's *Great Silver River* (2d ed. 1890).

La Porte, capital of La Porte county, Indiana, at the junction of several important railways, 50 miles ESE. of Chicago. It manufactures wooden and woollen goods, and ships large quantities of ice. Pop. 7195.

Lappenberg, JOHANN MARTIN, a German historian, was born 30th July 1794, in Hamburg, and pursued historical and political studies in Edinburgh, London, Berlin, and Göttingen. He became the representative of his native city at the Prussian court in 1820, and in 1823 was appointed keeper of the archives to the Hamburg senate, an appointment which he held for forty years. He died at Hamburg on 28th November 1865. The book by which he is best known is the careful and painstaking *Geschichte von England* (2 vols. 1834-37), which was continued by Pauli (3 vols. 1853-58), and translated into English by B. Thorpe (3 vols. 1845-57). Besides this Lappenberg completed Sartorius's *History of the Origin of the German Hansa* (2 vols. 1830), wrote books on the history of Heligoland and the Steelyard in London, and edited

valuable historical documents relating to Hamburg and Bremen, and old chronicles, such as Thietmar of Merseburg, Arnold of Lubbeck, &c. These latter for Pertz's *Monumenta Germanica Historica*. See Memoir by E. H. Meyer (1867).

Lapsed (*Lapsa*), the designation applied, in the early centuries of the Christian church, to those who, overcome by heathen persecution, did not continue faithful to the Christian religion. They were distinguished according as they had sacrificed (*sacrificati*) or burned incense (*thurificati*) to idols, or had purchased a certificate (*libellus*) from the authorities to the effect that they had done so (*libellatici*). Afterwards, during the Diocletian persecution, those were included among the lapsed who had given up copies of the Scriptures (*traditores*). The lapsed were at first punished by excommunication, and their reception into the church again was strenuously resisted; but in the 3d century a milder course was generally adopted with regard to them. The treatment of the lapsed was one of the practical questions most earnestly discussed in the early church. See NOVATIANS, also DONATISTS.

Lapwing (*Vanellus vulgaris*), a common British bird in the plover family Charadriadae. The familiar cry is echoed in the names *Peewit*, Scotch *Pee-weep*, Old English *Wape*, and French *Deshout*, while the regular, slow flapping of the long, rounded wings is referred to in the title lapwing. It

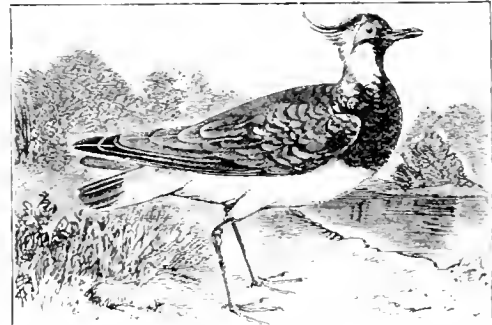

Lapwing (*Vanellus vulgaris*).

usually resides in Britain all the year, and is widely distributed across Europe and Asia. Its haunt are marshy pastures and moorlands; its food worms, slugs, and insects; its nest little more than a depression in the ground; its eggs, four in number, olive green to stone-buff in ground colour, with blackish brown blotches, are laid in April. When disturbed the female runs from the nest, while her mate, with devils flight and anxious cries, strives to divert attention away from the nest. After the young are hatched, the parents both exhibit loving solicitude. The adults are about a foot long, with crested head and very beautiful plumage, which almost baffles brief description. The birds themselves are eaten, and the eggs are highly esteemed. Most of the plover eggs sold in Britain are lapwings' eggs gathered in the Netherlands and North Germany. See PLOVER; and Howard Saunders, *Manual of British Birds*.

Lar, capital of the district of Laristan, in south Persia, situated on a well wooded plain, 60 miles from the Persian Gulf and 170 S.E. of Shiraz; with trade in tobacco, cotton, and grain. Pop. 12,000.

La Ramée. See OUDA.

Laramie, a river which rises in northern Colorado, flows generally N.E. through south-eastern Wyoming, and enters the North Fork of the Platte at Fort Laramie, after a course of about

200 miles. It gives name to a large county of Wyoming; to the Laramie Plains, a treeless plateau of Wyoming, about 7500 feet above sea-level, and some 3000 sq. m. in extent; and to the Laramie Mountains, a Rocky Mountain range which bounds this plateau on the north and east. Laramie City, Wyoming, on this great plain, and on the Union Pacific Railroad, 573 miles W. of Omaha, has a rolling-mill and railway shops. Pop. 6388.

LARAMIE BEDS. The name given by American geologists to certain strata which appear to be intermediate in age between the Cretaceous and Tertiary. The strata are well developed in Utah and Wyoming, and consist chiefly of lacustrine strata; they contain numerous seams of lignite, and hence are often called the lignitic series. While the vertebrate remains of the Laramie are essentially Mesozoic in character, the plants are just as unequivocally Tertiary. It would seem from this that a Tertiary flora was contemporaneous with a Cretaceous fauna.

Larboard. See STEERING.

Larceny. See THEFT.

Larch (*Larix*), a genus of trees of the natural order Coniferae, differing from firs (*Abies*) in having the cones ovate-oblong, about an inch in length, the scales of which are attenuated at the tip, and not falling off from the axis of the cone when fully ripe, and the leaves deciduous and in clusters, except on shoots of the same year, on which they are single and scattered. The Common Larch (*L. europaea* or *Abies Larix*) is a native of the mountains of the south and middle of Europe, and is found also in Asia, where it extends much farther north than in Europe, even to the limits of perpetual snow. The date of the introduction of the larch into Britain is fixed by some authorities at about 1629; but it was for many years treated as a rare and curious plant, and grown in pots in green-houses by the few that possessed it, till about the middle of the 18th century,

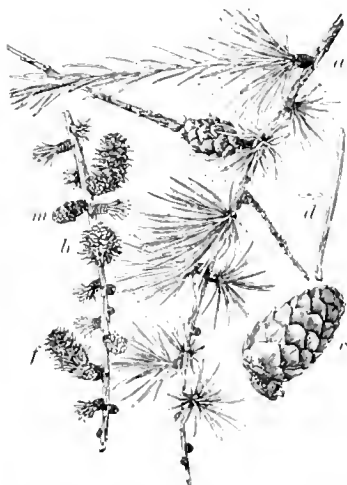

Common Larch (*Larix europaea*):
a, twig with shoots; b, twig with male (m)
and female (f) flowers; c, mature cone;
d, needle with section.

when it began to be extensively planted as a forest-tree. It has changed the aspect of whole districts, particularly in Scotland, where it was introduced at Dawick, Peebleshire, in 1725, and at Dunkeld and Blair, Perthshire, in 1738. The perfectly erect and regularly tapering stem of the larch, its small branches, its regular conical form, and its very numerous and very small leaves, make its aspect peculiar, and very different from that of any other tree seen in Britain. It attains a height of 60 to 100 feet, and an age of 200 years. The larch grows rapidly, and is useful even from an early age; the thinnings of a plantation being employed for hop-poles, palings, &c., and the older timber for a great variety of purposes. It is very resinous, does not

readily rot (many notable Italian pictures are painted on panels of larch), is not readily attacked by worms, and is much used in shipbuilding. It is, however, very apt to warp, and is therefore not well suited for planks. Larch bark is used for tanning, although not nearly equal in value to oak-bark. In Siberia, where large tracts of larch-forest are not unfrequently consumed by accidental fires, the scorched stems yield, instead of a resin, a gum similar to gum-arabic, reddish, and completely soluble in water, which is known as *Orenburg Gum*, and is used for cementing and in medicine, and, notwithstanding a somewhat resinous smell, even as an article of food. In warm countries a kind of Manna (q.v.) exudes from the leaves of the larch in the hottest season of the year, having a sweetish taste, with a slight flavour of turpentine. It is gathered principally in France, and is known as *Briançon Manna*, or *Larch Manna*. The larch woods of Britain have of late years suffered greatly from a disease in which the centre of the stem decays; the nature and causes of this disease are very imperfectly understood, but it seems to be sufficiently ascertained that those plantations are peculiarly liable to it which are formed where any kind of fir has previously grown, and those least so which are regularly thinned, so that the trees enjoy abundance of fresh air. The larch does not dislike moisture, but stagnation of water is very injurious to it, and thorough drainage is therefore necessary. There are varieties of the common larch remarkable for crowded branches, for pendulous branches, and for other peculiarities, which are sometimes planted as ornamental trees. The Common American Larch (*L. americana*)—the Tamarack or Hackmatack—distinguished by very small cones, is common in the northern parts of North America, and on the Alleghany Mountains, often covering extensive tracts. It is a noble tree, much resembling the common larch, and its timber is highly valued. Other American species are the Western Larch (*L. occidentalis*)—also called Tamarack—and the smaller, alpine, *L. Lyallii*. The Himalayan Larch (*L. Griffithsii*) abounds in the Himalayas, but is generally a small tree, 20 to 40 feet high. Its cones are larger than those of the common larch. The Golden Larch (*L. Komperi*), a native of Japan, is described by Fortune, who introduced it in 1832, as a beautiful tree growing to the height of about 120 to 130 feet, with corresponding girth of bole. It has not proved hardy in any except the mildest parts of Britain. See C. Y. Michie, *The Larch* (Edin. 1882).

Lard, the fat of the hog. Until after the first quarter of the 19th century lard was only used for culinary purposes and as the base of various ointments in medical use. The enormous extent, however, to which pork was raised in America rendered it necessary to find some other applications for so valuable a material, and large quantities were pressed at a low temperature, by which the stearine and oleine were separated. The former was used for candle-making; and the latter soon became an important article of commerce as a lubricant, under the name 'lard oil,' which was found to be a valuable lubricant for machinery. See OIL, STEARINE.

Lardner, DIOXYSIUS, a successful populariser of physical science, was born in Dublin, 3d April 1793, and, after four years as clerk to his father, a solicitor, entered Trinity College. He first attracted attention by a *Treatise on Algebraic Geometry* (1823), and a work on *Differential and Integral Calculus* (1825). But he is best known as the originator and editor of *Lardner's Cyclopaedia*, a series of 132 volumes on scientific subjects, published between 1830 and 1844. Lardner himself wrote the volumes treating of

mechanics, hydrostatics, geometry, arithmetic, heat, and electricity. This was followed up by the historical series entitled the *Cabinet Library* (12 vols. 1830-32) and *Museum of Science and Art* (12 vols. 1854-56). He also wrote several useful handbooks of various branches of natural philosophy. In 1828 Lardner had been appointed professor of Natural Philosophy and Astronomy in University College, London; but in 1840 he lost his chair through running away with the wife of an army officer, who claimed £8000 damages from him. However, Lardner went to the United States, and there made five times that sum by lecturing. He lived in Paris from 1845 to 1859, and died at Naples on 29th April 1859.

Lardner, NATHANIEL, an English divine, was born at Hawkshurst, in Kent, in 1684, and studied in London, afterwards at Utrecht and Leyden. He belonged to a body of English Presbyterians who had become Unitarians. He died at Hawkshurst on 24th July 1768. His *Credibility of the Gospel History* (2 vols. in 1727 and 12 vols. in 1733-55) and his *Jewish and Heathen Testimonies* (4 vols. 1764-67) have secured for him a place among the modern apologists for Christianity. See the Life by Kippis prefixed to his works (10 vols. 1788).

Larcan, EDMUND, French Canadian author, was born at St. Gregoire, Province of Quebec, 12th March 1848, and was educated at the college of Ste. Marie de Mannoir, at Victoria College, and at McGill University. He was called to the bar in 1870, became professor of Law in McGill University in 1876, and in 1886 was elected in the Liberal interest to the provincial legislature. His works, written in French, include histories of Canadian law (1872) and literature (1874), and *Melanges historiques et littéraires* (1877).

Lares, Penates, Manes. The Lares were tutelary deities belonging originally to the Etruscan religion, and worshipped especially as the protectors of a particular locality. In Roman usage they were usually regarded as the tutelary deities of a house (*familiares* or *domestici*), and their images stood on the hearth in a little shrine (*achæ*), or in a small chapel (*lararium*). We find also *Lares compitales* (of cross-roads), *Lares vicinarii* (of streets), *Lares rurales* (of the country), &c. See ANCESTOR WORSHIP.

The Penates were the old Latin guardian deities of the household, and of the state regarded as a union of households. Their seat was originally in Lavinium, and the name is generally joined with *Di*. By a natural enough case of metonymy both the words Penates and Lares came to be used as equivalent to a home or a hearth.

The Manes were the deified souls of the departed, the gods of the Lower World considered as benevolent spirits, in contrast to *laræ* and *lemures*, malevolent spirits; but the name frequently applied merely to the departed spirit, ghost, or shade of a dead person.

These divinities were by no means exactly differentiated from each other, and obviously all owed their existence to the fundamental ideas underlying the worship of ancestors, with its altar, the domestic hearth—the most persistent and perhaps the oldest of all the religions of man.

Largo, a village of Fife, on Largo Bay, and at the base of Largo Law (965 feet), 13 miles N.E. of Kirkeady. It has a bronze statue by T. Stuart Burnett (1885) of Alexander Selkirk, who was born here. Pop. of parish, 2324.

Largo, an Italian word, used in music, to denote very slow time, and especially in compositions where the sentiment is quite solemn. *Larghetto* is the diminutive of *Largo*, the time being slightly quicker.

Largs, a watering-place of Ayrshire, on the Firth of Clyde, 14 miles S. of Greenock, and 11 N. of Ardrossan by a railway opened in 1885. Here on 12th October 1263, in a war between Scotland and the Norse colonies of Man and the Isles, Alexander III. defeated Haaco of Norway, who with 160 ships and 20,000 men had descended on the coast of Ayrshire. Pop. (1851) 2824; (1891) 3187. See *Wemyss Bay and Largs* (Paisley, 1879).

Laricio. See PINE.

Larida. See GULL.

Larissa (called by the Turks *Yenisher*), famous in ancient times as the chief town of Thessaly, is now a place of 13,169 inhabitants, one-third Greeks and one-third Turks. Larissa was ceded by Turkey to Greece in 1881. It stands on the *Salambría* (anc. *Peneus*), in the fertile plain of Thessaly, and has manufactures of silk, cotton, and tobacco. It was the centre of the Turkish operations in the war of Greek Liberation, and was occupied by the Turks in the war of 1897.

Laristan, the south-west part of the Persian province of Kerman (q.v.). Area, 22,954 sq. m.; pop. about 90,000.

Lark (*Alauda arvensis*), a familiar songster, otherwise well known as the symbol of poets and the victim of epicures. It is included among Passerine birds, type of the family Alaudidae,

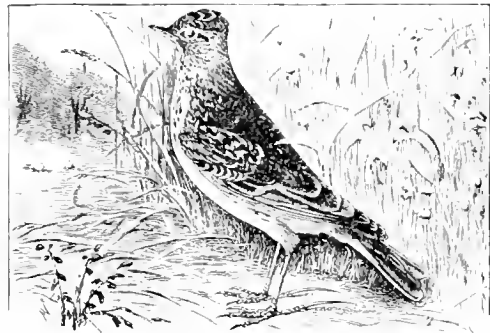

Lark (*Alauda arvensis*).

which comprises over 100 species, widely distributed in Europe, Asia, and Africa, with straggling in Australia and North America. The plumage is usually sandy brown, the colour of the ground; the lower legs bear scales, behind and before; the hind-claw is very long and straight; the bill is strong and conical. The skylark measures about 7 inches in length; the males and females are alike in plumage; the food consists of insects, worms, and seeds. It nests in April, making a structure of dry grass in a hollow in the ground, usually among growing grass or cereals. The eggs (three to five) are dull gray, mottled with olive-brown; two broods are usually reared in the season. Great crowds of larks come to Britain from the Continent in autumn, and later on there is a general movement southwards. It has been introduced into Australia and New Zealand, and to some extent in the United States.

'The lark is a creature of light and air and motion, whose nest is in the stubble and whose trust is in the clouds.' Its song 'at heaven's gate,' idealised by Shelley, Wordsworth, Hogg, and other poets, 'is not especially melodious, but blithesome, sibilant, and unceasing.' 'Its type,' Burroughs well says, 'is the grass, where the bird makes its home, abounding, multitudinous, the notes nearly all alike and in the same key, but rapid, swarming, prodigal, showering down as thick and fast as drops of rain in a summer shower.' The bird very

rarely sings on the ground, but when soaring or descending.

There is no doubt that larks when very numerous, as they often are, may do considerable damage to autumn-sown wheat or young green crops. This fact is sometimes urged to excuse the custom of catching them for the cage or table. They are caught in horse-hair nooses, or netted, or shot after being attracted and mesmerised by 'twirling' some bright glistening object. It is estimated that, during last century, in Leipzig alone over five million larks were received annually; in 1854 there were brought to the London markets over 400,000; and the official returns state that in 1867-68 more than a million and a quarter were taken into Dieppe.

In Europe there are several other common species of lark—e.g. the Wood-lark (*L. arborea*) and the Crested Lark (*L. cristata*), the former of which is locally distributed in England and Wales, and the latter a rare visitor. Among the other genera may be noted the Shore or Horned Larks (*Otocorys*), with a hornlet over each eye; these are 'the only larks which occur regularly in the western hemisphere.' One species (*O. alpestris*) has occasionally been found as a straggler in Britain, just as the species of *Alauda* occasionally wander beyond their usual range.

Larkhall, a small town of Lanarkshire, 3 miles S.E. of Hamilton, with coal-pits and mills. Pop. 8349.

Larkhana, the capital of a district called the Eden of Sind, stands 150 miles N. of Hyderabad by rail. It manufactures silk and cotton cloth, and has a great cotton market. Pop. 13,188.

Larkspur (*Delphinium*), a showy and popular genus of garden-flowers of the natural order Ranunculaceæ, natives of the temperate and cold regions of the northern hemisphere, and comprising both annual and perennial species. The well-known Rocket Larkspur (*D. Ajacis*), a native of Switzerland, and the Branching Larkspur (*D. consolida*), a native of most parts of Europe, doubtfully so of Britain, are familiar examples of the annual species; and Barlow's Larkspur (*D. Barlowii*) and the Great-flowered Larkspur (*D. grandiflorum*) are not unfrequent examples of the perennial species; but many more showy varieties have been produced by cultivation and selection which have displaced the older-fashioned species. *D. glauciale* is one of the most distinctively alpine plants in the world. *D. Staphisagria*, corrupted to *Stavesacre*, yields an alkaloid extract from its seeds, named *Delphinine*, which is highly poisonous even in very small doses, acting chiefly on the nervous system.

Larnaka (ancient *Citium*), the chief port of Cyprus, 27½ miles S. of Nicosia. A small fort built by the Turks in 1625 is now used as the district gaol, and the English have built a convenient courthouse, custom-house, and other public offices on the sea front, as well as two iron piers accessible at all times by small boats. Sea-going vessels are obliged to lie ½ mile from the shore owing to the shallow water. The Greek church of St Lazarus, an ancient Byzantine building, is in good preservation, and there is an English burial-ground attached to it with monumental inscriptions as old as 1685. Even if *Citium* be not the *Citium* of the Old Testament, it is certain that the king of *Citium* paid tribute to the Assyrian Sargon in 707 B.C. as appears from a cuneiform inscription on a bas-relief dug up at Larnaka in 1846, and now in the museum at Berlin. Carobs, or locust-beans, cotton, and grain are exported; and goods of western manufacture of all kinds are imported, chiefly from Germany. A most interesting fair called *katakismos*, 'the deluge,' and held every

year fifty days after the Greek Easter, is traditionally supposed to be the anniversary of the birth of Aphrodite, and is attended by Orthodox Christian Cypriots from all parts of the island in immense numbers (cf. *Herodotus*, i. 199). Pop. 7833.

Larne, a market and seaport town of County Antrim, at the entrance of Lough Larne, 25 miles N.E. of Belfast by rail. There is daily communication with Stranraer by mail-steamer. Pop. 4522.

La Rochefoucauld, FRANÇOIS, DUC DE, was born at Paris on the 15th September 1613. He belonged to an old family, and his father was made a duke by Louis XIII. in 1622. During his youth he was known as the Prince de Marsillac. His education was somewhat neglected. He joined the army when a boy, and was present in his seventeenth year at the siege of Casal. His life, says Sainte-Beuve, might be divided into four periods, to each of which might be assigned the name of a woman—viz. Mme de Chevreuse, Mme de Longueville, Mme de Sablé, and Mme de la Fayette. As a young man he showed an ultra-romantic temperament. Under the influence of Mme de Chevreuse he devoted himself to the cause of the queen in opposition to Richelieu, and became entangled in a series of love-adventures and political intrigues, the result being that on the flight of Mme de Chevreuse he was forced to live in exile at Vertueil from 1639 to 1642. About 1645 he formed a liaison with the beautiful Mme de Longueville. He then joined the Frondeurs and was severely wounded at the siege of Paris. He was very unlucky in his political schemings. His father died in 1650, and in 1652 he was again badly wounded, whereupon he retired to the country to restore his health, which had been shattered by twenty years of battle and adventure. On Mazarin's death in 1661 he repaired to the court of Louis XIV., and about the same time began his liaison with Mme de Sablé. A surreptitious edition of the *Mémoires*, which he had written while living in retirement, was published by the Elzevirs in 1662, and as the book gave wide offence he disavowed its authorship, without, however, finding many to accept his denial. His *Reflexions, ou Sentences et Maximes Morales* appeared in 1665. No book, said Voltaire, did more to form the taste of the nation. The first edition contained 316 *maxims*, which were afterwards expanded to about 700. His last years were brightened by his friendship with Mme de la Fayette, which lasted until he died at Paris on March 17, 1680. In his early life he had married Andree de Vivonne, by whom he had five sons and three daughters.

The *Maxims* vary in length from two or three lines to about half a page. For brevity, clearness, and finish of style they could hardly be excelled. Their writer did not seek to play the part of the mere epigrammatist, though he has now and then sacrificed his thought for the sake of striking and pointed expression. A vein of melancholy runs through the book. It is the work of a man of singularly keen and subtle intellect, who was deeply versed in life, and had formed independent judgments on most of its relations. He was a remorseless analyst of man's character. 'Everything is reducible to the motive of self-interest'—such is usually said to be the key-note of all his philosophy. That is not, however, exactly correct, though it is true of the book in the main. La Rochefoucauld tracks out self-love in its most elusive forms and under its cunningest disguises. He lays it bare with the most piercing insight and pitiless trenchancy. But he occasionally overstates his case against humanity, through forgetfulness of the fact that self-love is not the only motive by which men are impelled. Read in certain moods, the *Maxims*

seem a crushing exposure of man's baseness and folly; read in others, they seem little better than a morbid libel on human nature. But of their writer's depth and keenness as a thinker there can be no more question than there can of his wonderful mastery of terse and incisive phrase.

See French Life by Bourdieu (1895), and the article on 'La Roche-toucauld' included in Sainte-Beuve's *Portraits de Femmes*. The best edition of his works is that by Gilbert and Gourdaud (3 vols, 1868-84), in the series of *Grands Ecrivains de la France*.

Larochejaquelein. DU VERGER DE, an old noble family of France. The name Du Verger is derived from a place in Poitou. Guy du Verger married, in 1505, the heiress of the seigneur of Larochejaquelein. Several of his descendants distinguished themselves by their devoted loyalty to the old royal house against the fury of the French Revolution.—HENRI, Comte de Larochejaquelein, born in 1772, was an officer in the guard of Louis XVI., and after the 10th of August 1792 left Paris to put himself at the head of the insurgent royalists in La Vendée. He signalled himself by many heroic deeds, and for a time successfully repelled the republican forces, but was severely defeated by Westermann, 21st December 1793, and escaped with difficulty. He raised a new body of troops, however, in Upper Poitou, but was killed in a battle at Nonafle, 4th March 1794. His heroic words to his soldiers are memorable beyond most: 'Si je recule, tuez-moi; si j'avance, suivez-moi; si je meurs, vengez-moi!'—His brother, LOUIS DU VERGER, Marquis de Larochejaquelein, born in 1777, emigrated at the commencement of the Revolution; returned to France in 1801, but resisted all Napoleon's efforts to win him, and in 1813 placed himself at the head of the royalists in La Vendée. Louis XVIII. appointed him in 1814 to the command of the army of La Vendée, and during the Hundred Days he maintained the royalist cause there, supported by the British. He fell in battle at Pont-des-Mathis, 4th June 1815. His wife, MARIE-LOUISE VICTOIRE, Marquise de Larochejaquelein (1772-1857), published *Mémoires* of the war, of which she was an eye-witness (Bordeaux, 1815), which are of real value to the historian. See her Life by Nettement (3d ed. Paris, 1876).

La Rochelle. See ROCHELLE.

Larrey. DOMINIQUE JEAN, BARON, a celebrated French surgeon, was born at Beaudéan, near Bagnères-de-Bigorre, in the Pyrenees, in July 1766, studied medicine in Toulouse, and after graduating served as surgeon in the navy. But in 1793 he transferred his skill to the army, and introduced the 'flying ambulance' service. After teaching for a short time at Toulon and Val de Grâce, he joined Napoleon in Italy in 1797; and from that time onwards invariably accompanied the successful Corsican in his campaigns. In 1805 he was placed at the head of the medico-surgical department of the French army, and a few years later was created a baron of the empire. Larrey continued to fill important offices till 1836, when he retired from that of surgeon-general of the Hôpital des Invalides. He died at Lyons, 25th July 1842. From his pen came valuable treatises on army surgery and the treatment of wounds; they were translated into most European languages. See the German memoir by Werner (1885).

Larva. the young form of an animal after leaving the egg, but before acquiring adult characteristics. Tadpoles of Frogs (q.v.), caterpillars of Insects (q.v.), nauplii and zoeæ of Crustaceans (q.v.), the quaint young of Echinodermis (q.v.), &c. are good illustrations. There may be no larval stage, when the embryo grows continuously

into the adult form; on the other hand, the larval life may be longer than that of the adult. Many larval characters are recapitulations of ancestral forms; others are special modifications adaptive to larval life. See the Rev. J. Seymour's *Larva Collecting and Breeding* (1890).

Larynx (Gr. *larynx*) is the organ of voice, and plays an important part in the respiratory process, as all air passing either to or from the lungs must pass through it. It is a complex piece of mechanism, resembling a box composed of pieces of cartilage which are capable of executing movements, and enclosing the vocal-cords by which phonation is produced. The larynx is situated between the *trachea*, or windpipe, and the base of the tongue, at the upper and front part of the neck, where it forms a considerable projection (especially in men); it opens superiorly into the *pharynx*, or throat, and inferiorly into the windpipe. The principal cartilages of which the skeleton of the larynx is composed are five in number—viz. the thyroid and cricoid cartilages, the epiglottis, and the two arytenoid cartilages.

The *thyroid* (Gr., 'shield-like') consists of two square plates of cartilage united in front at an acute angle, which forms the projection commonly known as the *prominens Adami*, or Adam's apple. Each of these plates is prolonged at the upper and lower posterior corners. The thyroid cartilage forms almost the whole of the anterior and lateral walls of the larynx. The *cricoid* (Gr., 'ring-like') cartilage is a ring the lower margin of which is parallel to the first ring of the trachea, and to the last-named it is united by fibrous membrane. Its upper border is connected in front with the lower border of the thyroid cartilage by a thick yellow-fibrous tissue. It presents two articular surfaces on either side—viz. a lower, which articulates with the inferior cornu of the thyroid cartilage, and an upper, which is oval in form, and supports an arytenoid cartilage. The *arytenoid* (Gr., 'ladle-like') cartilages are pyramidal bodies resting on the oval articular surfaces at the upper and posterior part of the cricoid cartilage.



Fig. 1.

Cartilages of larynx and epiglottis, and upper rings of trachea, seen from behind: a, arytenoid cartilages; b, superior cornu of thyroid cartilage; c, its inferior cornu; d, posterior surface of cricoid; e, epiglottis, with its perforations; f, upper margin of thyroid; h, its left inferior tubercle; g, trachea.

When *in situ* they present a concave posterior surface. From their connection with the vocal cords, and from their great mobility as compared with the two larger cartilages, the arytenoids play a very important part in the mechanism of the larynx. The *epiglottis* is a very flexible cartilaginous valve (fig. 1, e), situated at the base of the tongue, and covering the opening of the larynx. Its direction is vertical, except during deglutition, when it becomes horizontal. It is attached inferi-

only by a kind of pedicle to the angle of the thyroid cartilage. Upon removing the investing mucous membrane the cartilage is found to be perforated by numerous foramina. Each perforation admits some fasciculi, of yellow, elastic, ligamentous tissue, which expands on its anterior aspect, and secures the return of the epiglottis to its vertical position, independently of any muscular action. Such is the skeleton of the larynx, hanging as it does from the hyoid bone, with which it is connected by the thyro-hyoid ligament and certain muscles.

The various cartilages which have been described are connected with one another by ligaments, the chief of which are those known as the true and false vocal cords. In their quiescent state the former do not lie parallel to each other, but converge from behind forwards. The length of the vocal cords is greater in the adult male than in the adult female, in the ratio of three to two. In infancy they are very short, and increase regularly from that period to the age of puberty. The mucous membrane of the larynx is part of the extensive respiratory tract, and is remarkable for its extreme sensibility. The length of the chink or aperture of the glottis, which is directed horizontally from before backwards, varies, like the

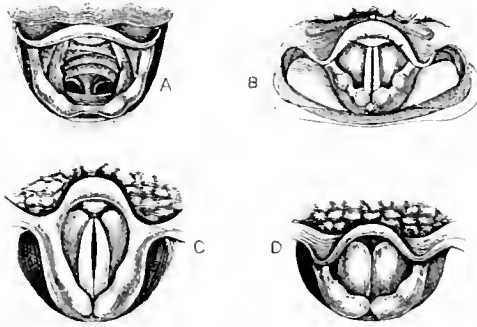

Fig. 2.

A, Larynx and trachea during deep inspiration; B, on phonation; C, during expiration; D, approximation of the ventricular bands or false cords as it occurs in straining.

vocal cords, until the period of puberty, when its length, in the male, undergoes a sudden development, while in the female it remains stationary. In the adult male it is about eleven lines in length.

The larynx is provided with two sets of muscles: the *extrinsic*, by which the whole organ is elevated or depressed, and the *intrinsic*, which regulate the movements of the various segments of the organ in relation to one another. By the action of these latter muscles, aided, in some cases, by the extrinsic muscles, the tension of the vocal cords may be increased or diminished, and the size of the opening of the glottis regulated at will (see VOICE). The nerves of the larynx are derived from the superior and inferior laryngeal branches of the pneumogastric or vagus nerve.

That the larynx is the organ of voice is easily proved. Thus, alteration in the mucous membrane covering the vocal cords causes hoarseness or other change of voice; ulceration of the vocal cords destroys or injures the voice; opening the trachea below the vocal cords, or section of the inferior laryngeal nerves, destroys the voice; and sounds like those of the voice may be produced by experiments on the dead larynx.

DISEASES OF THE LARYNX.—*Laryngitis*, or inflammation of the larynx, may be either an acute or a chronic affection. Acute laryngitis, in its more

severe form, which is fortunately rare, commences with a chill, which is followed by fever, with a full strong pulse, a hot skin, and a flushed face. There is also soreness of the throat, hoarseness of the voice, great difficulty in swallowing, and a feeling of extreme constriction of the larynx. There is a painful stridulous cough, but only a little mucus is ejected. Great difficulty in breathing occurs in severe cases, the act of inspiration being prolonged, and wheezing results, in consequence of the swollen membrane of the glottis impeding the entrance of air. On examining the larynx, the epiglottis is observed to be of a bright red colour, erect, and may be so much swollen as not to be able to descend, and may close the glottis during deglutition; the other parts of the larynx are seen to be more or less swollen according to the severity of the case. The patient may exhibit symptoms of great anxiety and distress; his lips may become blue, his face of a livid paleness, his pulse irregular and very feeble, and at length he may sink into a drowsy state, often preceded by delirium, and quickly followed by death. The disease is very rapid, ending, when fatal, in three or four days, and occasionally in less than one day. Although we have here described what may occur in exceptionally severe cases, acute laryngitis rarely passes beyond hoarseness, a feeling of constriction, slight feverishness associated with cough and marked hoarseness.

Laryngitis is most commonly due to exposure to cold; but the inflammation rarely reaches a dangerous height in these cases. The dangerous forms are usually the result of injury (e.g. swallowing boiling or corrosive substances); or they may be a secondary result of ulceration, or due to infection, such as erysipelas. In simple cases confinement to a warm room, with soothing steam inhalations, will, if the voice be rested, usually effect a cure. In severe cases sucking ice, leeching, scarification of the swollen parts, and even tracheotomy may be necessary. In persons who use the voice much the affection is apt to become chronic, or indeed to be chronic from the beginning without the super-vention of an acute attack. Laryngotomy is discussed at TRACHEOTOMY.

Ulceration may occur in phthisis, syphilis, lupus, and after typhoid fever. Cancer of the larynx may lead to ulceration, but the primary disease constitutes a tumour. Innocent growths are also met with, the more common varieties being papillomata (warts) and fibromata. Paralysis of the laryngeal muscles may involve those muscles only which close the glottis, in which case the affection is often due to hysteria and easily cured. Paralysis of the muscles which open the glottis or affecting all the muscles is usually due to some grave disease of the nervous system, chest, or throat, and is often incurable. The treatment must depend upon the condition discovered by laryngoscopic examination in each case.

THE LARYNGOSCOPE.—Although successful attempts had been previously made by Garcia to explore the recesses of the larynx by means of a reflecting mirror, it was not until two German physiologists, Turek and Czernak, took up the subject, in 1857 and 1858, that the great importance of laryngoscopy was first generally recognised. The laryngoscope is a small mirror placed on a stalk attached to its margin, at an angle of from 120° to 150°, the stalk being about six inches in length. The mouthpiece of a large reflector, with a central opening through which the observer looks, is held between the molar teeth; or, what is better, the reflector may be attached to a spectacle frame or forehead band by a stiffly working ball-and-socket joint. The rays of the sun or of a good lamp are concentrated by means of this

reflector on the laryngeal mirror, which is placed against the soft palate and uvula. The laryngeal mirror, previously warmed, and introduced with the right hand, which rests by two fingers on the jaw, is maintained at such an inclination that it throws the light downwards and illuminates the parts to be examined, while at the same time it reflects the images of these parts into the eye of the observer through the central opening of the reflector. By this means we can look through the larynx into the trachea or windpipe, and can see the actual position of small tumours, ulcers, &c., whose existence would otherwise have been at most only suspected; and the precision and accuracy of diagnosis to which we can thus attain enable us to employ rational means of local treatment to an extent that was quite impossible before the introduction of laryngoscopy. It is also possible to illuminate the larynx by throwing a powerful and concentrated light upon the front of the throat, and introducing a mirror into the dark mouth (*Durchleuchtung* of German physicians).

La Salette. See SALETTE.

La Salle, a city of Illinois, at the head of steam-navigation on the Illinois River (here crossed by bridges), 99 miles by rail WSW. of Chicago, with which it is also connected by the Illinois Canal. Bituminous coal is mined here, and the city has a large zinc-rolling mill and smelting-furnaces, besides manufactures of glass and iron wares. Pop. 7847.

La Salle, ABBÉ DE. See SCHOOLS, CHRISTIAN.

La Salle, ROBERT CAVELIER, SIEUR DE, one of the greatest French explorers in North America, was born at Rouen in 1633. Settling in Canada at the age of twenty-three, he began his travels with an attempt to reach China by descending the Ohio River, which he supposed to empty into the Pacific. As soon as he found that the great southern streams drained into the Gulf of Mexico he formed the project of descending the Mississippi to the sea. After many and severe hardships this long voyage was concluded, and the arms of France set up at the mouth of the great river, on 9th April 1682. Two years later an expedition was fitted out to establish a permanent French settlement on the Gulf, which should secure France's claims to the Mississippi valley. But La Salle's bad fortune pursued him; he mistook Matagorda Bay for a mouth of the Mississippi, landed there, and then spent two years in unsuccessful journeys to discover the great river, while his colonists and soldiers gradually dwindled away. His harshness of manner, more than his want of success, embittered his followers, and he was assassinated by some of them in March 1687. See works by Francis Parkman (q.v.).

Lascar, in the East Indies, signifies properly a camp follower, but is generally applied to native sailors on board of British ships, as, for instance, the large steamers of the Peninsular and Oriental Company. The Lascars make good seamen, being both temperate and docile. They are mostly Mohammedans, and speak, besides their native dialects, a *lingua franca* based on Hindustani, with English, Arabic, and other words.

Lascaris, CONSTANTINE, a Greek scholar, who, after the capture of Constantinople by the Turks, fled to Italy, where he was instrumental in reviving the study of Greek. He was a descendant of the royal family of Nicea. Francesco Sforza, Duke of Milan, made him tutor to his daughter Hippolyta. But more important scenes of Lascaris' labours were Rome (where he settled in the train of Bessarion), Naples, and Messina; at this last city he taught rhetoric and Greek letters until his death in 1493. His Greek grammar, entitled *Erotemata*, and dated 1476, was the earliest Greek

book printed in Italy. His library, which is very valuable, is now in the Escorial.—JOHN or JANUS LASCARIS, a member of the same family, surnamed RHYNDAENUS, born about 1445, who also found an asylum in Italy after the fall of Constantinople, was employed by Lorenzo de Medici in the collection of ancient, especially Greek, classical authors. On the death of Lorenzo, Lascaris went to Paris, where he taught Greek with the countenance of Charles VIII. and Louis XII.; but he eventually settled in Rome, and was appointed by Leo X. superintendent of his Greek press and of a seminary for young Greeks. He was, moreover, employed as ambassador at the court of Francis I., and afterwards at Venice, and died in Rome in 1535. From Rome he edited several *editiones principes* of the Greek classics. His own works were chiefly grammatical, with a volume of letters and epigrams. See Villemain's *Lascaris, ou les Grecs du 15^{me} Siècle* (Paris, 1825).

Las Casas, BAROLOMÉ DE, Bishop of Chiapa, in Mexico, surnamed the *Apostle of the Indians*, was born in Seville in 1474. He studied at Salamanca, sailed with his father in the third voyage of Columbus, and again in 1502 accompanied Nicolas de Ovando, the new governor, to Hispaniola. Eight years later he was ordained to the priesthood. In 1511 he was summoned to accompany Diego Velasquez to Cuba, and he assisted in the pacification of the island, and its division into *repartimientos* or allotments of natives, and was rewarded in the usual way by an *encomienda* or commandery of Indians, held together with his friend Pedro de Renteria. But ere long a burning love for the unhappy natives and indignation at their sufferings filled his heart; and he gave up his own slaves, and went to Spain, where he prevailed on Cardinal Ximenes to send a commission of inquiry to the West Indies. Its proceedings by no means satisfying his zeal, he revisited Spain to procure the adoption of stronger measures for the protection of the natives. Finally, to prevent the entire extirpation of the native race by the toils to which they were subjected, he proposed that the colonists should be permitted to import negro slaves for the more severe labours of the mines and sugar-plantations; and the proposal was adopted. Las Casas has on this account been represented as the author of the slave-trade, although it has been proved to have existed before this proposal was made, and it should be remembered that afterwards he bitterly repented the advice that he had given. He also attempted to carry out Castilian peasants as colonists to the West Indies, but failed in his scheme, and spent eight years (1522-30) of mortification in austere seclusion and devoted study within the walls of a Dominican convent in Hispaniola. In 1530 he again visited Spain, and, after missionary travels in Mexico, Nicaragua, Peru, and Guatemala, returned to devote four years to advocate the cause that lay closest to his heart. During this period he wrote his *Veynte Razones* and his *Brevissimo Relacion de la Destruccion de los Indios*, which was soon translated into the other languages of Europe. The rich bishopric of Cuzco was offered to him, but he preferred the poor one of Chiapa, and reached its chief city, Ciudad Real, in 1544. He was received with the most active hostility by the colonists, and was soon mortified to the heart by Charles V.'s time-serving revocation of the New Laws, which his own devoted energy had extorted. He maintained his ground that the granting of *encomiendas* to private persons was flagrant injustice, but bowed his head to the storm, returned to Spain, and resigned his see (1547). Three years later he argued before a Junta at Valladolid with splendid force and eloquence against Sepulveda, who defended the right of carrying on war against

the Indians. In 1555 he appealed in terms of marvellous boldness to Philip II, not to sell the claims of the crown to the reversion of the *encomiendas*, and was successful in thus averting a measure which would have brought final and hopeless slavery upon the Indians. His last work was to get the *audiencia* or court of justice restored to the oppressed natives of Guatemala. He ended his life in a convent in Madrid, July 1566, at the age of ninety-two. His most important work, the unfinished *Historia de las Indias*, was printed in 1875-76. See the admirable Life by Helps (1868).

Las Cases, EMMANUEL DIEUDONNE, COMTE DE, the historiographer and companion of Napoleon in St Helena, was born in 1766, near Revel in Languedoc. He was a lieutenant in the navy before the Revolution, but then fled from France, and supported himself in England by private teaching. After Napoleon became consul, Las Cases established himself as a bookseller in Paris. A work that he wrote, *Atlas historique* (1803-4), attracted the attention of the emperor, who made him a baron, and employed him in the administration. After Waterloo he obtained leave to share the exile of Napoleon in St Helena, and there the ex-emperor dictated to him a part of his Memoirs. In 1816 Las Cases was sent back to Europe, and after Napoleon's death published *Memoirs de St-Helene* (8 vols. 1821-23), of which O'Meara's *Napoleon in Exile* is a kind of continuation. Both works attack Sir Hudson Lowe, Napoleon's keeper, charging him with undue harshness towards his prisoner. Las Cases died at Passy, 15th May 1842.

Laseo, JOHANNES A., or JAN LASKI, Polish reformer, was a man of high family and was born at Lask, in the modern government of Piotrkow, about 1499. He was educated at Cracow by his uncle, chancellor and primate of Poland, and chose to enter the church. He studied further in Rome and Bologna, was ordained in 1521, and two years later at Basel came in contact with Erasmus and Farel; the former by his will left his library to A Laseo. From this journey the young Pole returned in 1526, his mind greatly exercised with the question of church reform. At length he was caught in the current of the Reformation, and, quitting his native land in 1538, he settled at Louvain in the Netherlands. But a year or two later he moved to Emden in East Friesland. The countess of that little province appointed him superintendent of church affairs, and he used his influence to establish a presbyterian form of church government. The *Emden Catechism*, defining the religious doctrines of the East Friesland Church, was in great part his work. But in 1550 he accepted an invitation by Crammer to visit England; he had already passed the winter of 1548-9 there and became head of an influential congregation of Protestant refugees in Austin Friars, London. Mary's accession in 1553 drove him back to Emden and scattered his flock. After staying a while in Frankfort-on-Main, he finally returned to Poland in 1556. There the Reformation was making rapid headway, and was assisted in no inconsiderable degree by the labours of A Laseo as superintendent of the churches in Little Poland. He died at Peczow, on 8th January 1560. See Dalton's *John a Laseo* (Eng. trans. from the German, 1886), which only brings the narrative down to A Laseo's second arrival in England; G. Pascal, *Jean de Laseo* (1894).

Lashkar. See GWALTOR (city).

Las Palmas, chief town of the Canary Islands (q.v.), on the north-east coast of Gran Canaria, is the seat of a bishop, and has sea-bathing and ship-building yards. Pop. 17,554.

Lassa. See LBASSA.

Lassalle, FERDINAND, who may justly be regarded as the historic originator of the social-democratic movement in Germany, was born at Breslau, April 11, 1825. Like Karl Marx, the founder of international socialism, he was of Jewish extraction. Lassalle's father was a prosperous merchant, who intended that his son also should follow a business career. But as young Ferdinand preferred a student life, he went to the universities of Breslau and Berlin, where he devoted his time chiefly to philology and philosophy. In philosophy he was a disciple of Hegel; and it was his first literary ambition to write a work on Heraclitus from the Hegelian point of view. During a stay in Paris he made the acquaintance of Heine, who, like so many of Lassalle's friends, formed the highest opinion of his talent and energy.

On his return to Berlin in 1846 he met the Countess Hatzfeldt, a lady at variance with her husband, a wealthy German noble of high rank. Taking up her case, Lassalle prosecuted it before thirty-six tribunals, and after eight years of litigation forced the husband to a compromise on terms most favourable to the countess.

As a decided adherent of the democratic republic Lassalle took a part in the revolution of 1848, and for disobedience to the authorities at Düsseldorf, where he then resided, spent six months in prison. He lived in the Rhine country till 1858, when he returned to Berlin; and at the same date brought out the work on Heraclitus, which had been laid aside during the Hatzfeldt suit. It at once gave him a high place in the learned circles of Germany. In conducting the Hatzfeldt case Lassalle had gained a very considerable legal knowledge, and this he now utilised in writing a work on the philosophy of law, entitled *System of Acquired Rights* (1861). It was an attempt to apply the historical method to legal ideas and institutions, but we may well question whether he has not often read into history theories of very doubtful validity.

For many years after 1848 no opportunity for fruitful action had occurred to men of democratic opinions. The opening of the Bismarck era in 1862 was therefore a welcome event for Lassalle, the aim of the latter being to resuscitate the democracy in face of the half-hearted Liberalism of his time. His first effort was to show the futility of the Liberal policy in opposing army reform. A lecture delivered in the spring of 1862 'On the connection of the present period of history with the idea of the working-class' strongly brought out the contrast between Lassalle's position and the Liberalism of his day. In his *Open Letter* to a committee of German workmen at Leipzig (1863) he still more clearly expressed his dissent from the current Liberalism, and in luminous and comprehensive language expounded the leading points of his social democratic programme. His success in advocating his views now encouraged him at Leipzig to found the Universal German Workingmen's Association. Its programme was a simple one—by all legal means to agitate for universal suffrage. In the autumn of 1863 Lassalle continued his agitation on the Rhine, and in the winter of 1863-64 he attempted to gain Berlin over to his cause, but without success. The chief literary product of the winter was his *Bastiat-Schulze, or Capital and Labour*, in which he attacked Schulze-Delitzsch, the prominent representative of German Liberalism. In May 1864 Lassalle held the last 'glorious review of his army' on the Rhine.

In the summer of 1864 Lassalle met on the Rigi Helene von Donniges, a lady whom he had previously known, and by whom he had been fascinated. They resolved to marry, but encountered the strongest opposition from the

lady's parents. Under pressure from them the lady at last renounced Lassalle in favour of the Wallachian Count Racowitza. Mad with rage and mortification, Lassalle went to both her father and lover a challenge, which was accepted by the latter. At the Carouge, a suburb of Geneva, Lassalle fell mortally wounded, and died two days afterwards, August 31, 1864. His unworthy end in such a miserable affair can hardly be regarded as an accident; it was the outcome of the weaker elements in a remarkable character.

Lassalle has left no systematic exposition of his views. In the *Bastiat-Schulze*, which is the nearest approach to such an exposition, we find philosophic statement too frequently interrupted by unprofitable controversy and unjustifiable abuse of his opponent. We can only glean from his works the most important points of his teaching. Lassalle held that the historical development of Europe is to culminate in a democracy of labour, in which political interests shall be subservient to social—the social democracy. The democracy of workers, who are destined to be the makers and representatives of the new order, are to be guided by science and the highest ideals of culture and morality. But they cannot by their isolated efforts fulfil this high mission; they need organisation. This organisation they will find in the state, which is, and should be, simply the great association of workers, inasmuch as they constitute the overwhelming majority of every community. The Liberal or bourgeois regime has degraded the state to the function of policeman or mere protector of property. It will be the aim of the new epoch to raise the state to its high and ancient position, as the promoter of freedom, culture, morality, and progress; its mission is the development of the human race in the way of freedom.

The working-class, however, need adequate material means to enable them to rise to the high vocation reserved for them. At present they are crushed by the *iron law of wages*, the law which holds the central and decisive position in the system of Lassalle, and which therefore requires a more lengthened statement. In his exposition of the law Lassalle founds on Ricardo and the classical economists generally. It was the doctrine of those economists that the workman's wage represents what is necessary for his subsistence (in accordance with the standard of living usual among his class) and for the continued supply of labour in his family. It is not a fixed quantity; it rises or falls according as the supply of labour decreases or increases in proportion to the demand for it. A rise in wages leads to greater comfort, more marriages, &c., and these tend to increase the supply of labour, and thereby again to lower wages. A fall in wages leads to want, sickness, abstinence from marriage, &c., and these tend to diminish the supply of labour, and thereby to raise wages. There is continual oscillation, but it never rises permanently above or falls permanently below the point necessary for subsistence and the continuance of the working class. Thus, so long as the present economic order, of which the iron law of wages is an implicate, continues, its inevitable operation leaves no hope of real improvement for the working-class; in other words, it follows from the iron law that the existing order must be fundamentally changed.

For the iron law of wages is merely an implicate in the regime of capital, the exposition of which is the main theme of the *Bastiat-Schulze*. With Lassalle capital is a historical category, the rise of which we can trace, the disappearance of which under altered circumstances we can foresee. The historical conditions necessary for the rise of capital were the opening of the world market through

geographical discovery, colonisation and conquest, the development of machinery, and of the division of labour, and above all the appropriation of the instruments of labour by a class, who, employing another class of labourers free but destitute of capital, pay them a subsistence wage and pocket the surplus. Thus the general exposition of capital leads us back again to the iron law of wages.

It is the gist of Lassalle's polemic against Schulze-Delitzsch that the working class cannot by their unassisted efforts escape from the iron law of wages. The state, whose function it is to promote and facilitate the great progressive movements of humanity, must furnish them with the necessary capital. As the easiest and mildest means of transition Lassalle brought forward his scheme of productive associations with state-credit, by which the workmen would be their own capitalists, would secure the full product of labour, and would thus gain for themselves the entire benefit of an ever-increasing production. His scheme would moreover provide the organic germ of an incessant development, for the associations would themselves combine into credit and insurance unions, until the industries of the whole country should form a well-ordered unity, superseding the present anarchic condition of things by a systematic, rational and equitable organisation of labour. As the associations would be self-governing, there would be most adequate guarantee for freedom; the state would simply see that its credit was not abused. In effect the socialism of Lassalle is a collectivism, resembling that of Rodbertus and Marx, but in many obvious points also differing from theirs. Since Lassalle's time, the political economy of Germany has been revolutionised, and the social democrats are an increasing power in the Reichstag and the country.

Bernstein edited for the social democratic party in 3 vols. an edition of Lassalle's socialistic writings (1891-94). See the articles MARX, SOCIALISM; monographs on Lassalle by Bernstein (Eng. trans. 1893), Brandt (1895), Aberg (1883); Brandes, *Ferdinand Lassalle* (2d German ed. 1888); Mehring, *Geschichte der Deutschen Sozialdemokratie*; Laveleye, *Le Socialisme contemporain* (Eng. trans. *Socialism of Today*); J. Eac, *Contemporary Socialism*; W. H. Dawson, *German Socialism and Ferdinand Lassalle*; the Countess Racowitza's *Memoirs* (1879); and George Meredith's *Tragic Comedians*.

Lassell, WILLIAM, astronomer, born at Bolton, in Lancashire, on 18th June 1799, belongs to that class of observers who have created their own instrumental means. He built himself a private observatory at Stanfield, near Liverpool, about 1820, and observed there down to 1861. There, too, he constructed and mounted equatorially reflecting telescopes of 9 inches aperture and 2 feet aperture successively. The speculum of the latter was polished by means of a machine of Lassell's own invention. With this same telescope he discovered the satellite of Neptune (1847); the eighth satellite of Saturn (1848), simultaneously with Prof. Bond of Harvard; and two new satellites of Uranus (1851). In 1861 he went out to Malta, and there set up a reflecting telescope of 4 feet aperture and 37 feet focal length, mounted equatorially; with this he made observations until 1865, chiefly of nebulae and the satellites he had discovered. After his return to England he transferred his observatory to near Maidenhead. There he died on 5th October 1880. See *Memoirs of Astron. Soc.*, vol. XXXVI., for his work in Malta, and *Trans. Roy. Soc.* (1874) for a description of his polishing-machine.

Lassen, CHRISTIAN, orientalist, was born on 22d October 1800, at Bergen, in Norway, and studied at Christiania, Heidelberg, and Bonn. He assisted Schlegel in the publication of the *Ramayana* and

Hitopadesa, and translated into Latin Jayadeva's *Gitagovinda*. He also associated himself with Eugene Burnouf in the *Essai sur le Pali* (Paris, 1826). In 1830 he became extra-ordinary and in 1840 ordinary professor of Ancient Indian Languages and Literature at Bonn, and taught there until disabled by blindness in 1864. He edited many Sanskrit works, deeply investigated the relations of the oriental languages and antiquities, and published several very important books. Amongst them are works on Persian Cuneiforms (1836 and 1845); on the Greek Kings in Bactria (1838); *Institutionis Linguae Praeceptiva* (1837); his great work on *Judische Alterthumskunde*, a critical history of Indian civilisation (1844-61; new ed. 1867-74), &c. He has contributed much to our knowledge of the cuneiform inscriptions, of the inscriptions of ancient Italy, and of the ancient and modern Iranian dialects. He was one of the co-founders of the *Zeitschrift für die Kunde des Morgenlandes*. Lassen died at Bonn, 9th May 1876.

Lasso (Spanish *lazo*), a thin, well-plaited rope of raw hide, used in Spanish America for catching wild cattle. One end is fastened to the saddle gear of the man who uses it, the other ends in a small brass ring, by means of which a running noose, usually 8 feet wide, is formed. The rider holds a coil of the lasso in the left hand; with the right he dexterously whirls the open noose round his head, and hurls it (to no great distance, but with a wonderfully sure aim) so as to fall over a given object—round the horns of a wild ox, or the like. In Mexico the lasso is *la veta* ('the rope'); thence the term *larial* for a kind of lasso in the United States. The lasso has been used in warfare with deadly effect. See BOLAS.

Latakia (Turk. *Ladikiyeh*), a decayed seaport of Syria, with a sanded-up harbour, stands on a rocky cape 75 miles N. of Tripoli. It possesses remains of Roman buildings, having been a flourishing port during the early empire; it was still a wealthy city at the time of the Crusades. The present town occupies the site of the ancient *Ladicea ad Mare*, which was founded by Seleucus Nicator, and named after his mother. Pop. estimated at 10,000, who export the Latakia tobacco, grown on the hills in the interior, and some grain, silk, sponges, oils, &c.

Lateau, LOUISE. See STIGMATISATION.

Lateen-sail, a large triangular sail, common in the Mediterranean. See SAIL.

Latent Heat. See HEAT, and EVAPORATION.

Latent Life, a phrase often used to describe the physiological condition of organisms in which the functions are for a time suspended, without losing the power of future activity. The condition is one of the grades between full life and total death, and was contrasted by Claude Bernard with the 'constant life' of most organisms, and with the 'oscillant life' of those which hibernates. It is illustrated by dry seeds and quiescent spores, by encysted ova and Protists, and by those animals and plants (e.g. paste-cells and lichens) which survive desiccation. See DESICCATION, LIFE.

Lateran, CHURCH OF ST JOHN, the first in dignity of the Roman churches, and styled in Roman usage 'the Mother and Head of all the churches of the city and the world'; as cathedral church of Rome it surpasses St Peter's in dignity. It is called Lateran from its occupying the site of the splendid palace of Plantius Lateranus, which, having escheated (66 A.D.) in consequence of Lateranus being implicated in the conspiracy of the Pisos, became imperial property, and was

given to St Sylvester by the Emperor Constantine. It was originally dedicated to the Saviour; but Lucius II., who rebuilt it in the middle of the 12th century, dedicated it to St John the Baptist; in 1586 it was completely demolished by Sixtus V., and rebuilt from plans by Fontana. It has been the scene of five councils, regarded as oecumenical by the Roman Church (see COUNCIL). The Lateran Palace was the habitual residence of the popes till the 14th century. It is now under the control of the Italian government. Pius IX. converted a portion of it into a museum of classical sculpture and early Christian antiquities. In the piazza of the church stands the celebrated relie called the 'Scala Santa,' or 'Holy Staircase,' which is reputed to be the stairs of Pilate's house at Jerusalem, made holy by the feet of our Lord as he passed to judgment.

Laterite, a mineral substance, the product of the disintegration and partial decomposition of various igneous and schistose rocks. It often attains a very considerable thickness, especially in tropical regions, where the heat is extreme and the rainfall at certain seasons is copious. In such regions the chemical decomposition of rocks is more or less rapidly effected, and the resulting products may be swept by the rains over wide areas. The earth so formed is generally red in colour, as in Ceylon, where in the dry season it is blown about as a fine dust, and imparts its hue to every neglected article and to the dresses of the inhabitants. The redness of the streets and roads attracts the notice of every stranger at Galle and Colombo. In the Deccan laterite derived from the decomposition of the basalts of the great plateaus reaches a thickness in many places of upwards of 150 feet. The red colour is due to the presence of iron oxide; but when this is absent or in small quantity the laterite may be whitish or yellowish.

Latex, in Botany, the sap of plants after it has been elaborated in the leaves. See SAP.

Latham, ROBERT GORDON, ethnologist and philologist, was born 24th March 1812, at the vicarage of Billingborough, in Lincolnshire. From Eton he passed in 1829 to King's College, Cambridge, of which in due course he was elected fellow. In 1842 he took the degree of M.D.; but nine years before a tour in Denmark and Norway had led him to direct his attention particularly to Scandinavian philology. From 1842 to 1849 he held appointments in connection with London hospitals; already in 1839 he had been elected professor of the English Language and Literature in University College, London; and in 1852 he became director of the ethnological department of the Crystal Palace. His first work was *Norway and the Norwegians* (1840), followed by translations from Tegner's *Fritiof's Saga*. His well-known work, *English Language*, published in 1841, went through numerous editions. The *Natural History of the Varieties of Man* (1850) was justly accepted as a valuable contribution to ethnology. Among his other works may be mentioned his edition of Tacitus's *Germania*, with philological and historical notes (1850); *Ethnology of the British Colonies* (1851); *Ethnology of the British Islands* (1852); *Man and his Migrations* (1851); *Descriptive Ethnology* (1859); *The Ethnology of Europe* (1852); *Native Races of the Russian Empire* (1854); a new edition of Johnson's *Dictionary* (1870); *Outlines of General or Developmental Philology* (1878). The fact should be specially emphasised that in 1862 Latham entered the field against Lassen, Bopp, Pott, Grimm, and Max Müller, declining to accept the central Asian theory of the 'good Aryan,' and affirming the view, since advanced by Penka, Schrader, Isaac Taylor, and Sayce, that the Aryan

race originated in Europe. He suffered for years from aphasia, and died at Putney 9th March 1888. Since 1863 he had been in receipt of a government pension of £100. See the long obituary by T. Watts in the *Athenæum* for 17th March 1888.

Lathe. See TURNING.

Lathom House, the seat of the Earl of Lathom, in Lancashire, 45 miles ENE. of Ormskirk. It is a Grecian mansion, built about 1750. Its predecessor was splendidly defended by Charlotte de la Tremouille, Countess of Derby, against Fairfax in 1644.

Laths. Laths are small strips of wood of various lengths, rarely more than 4 feet; they are made either by splitting lathwood, which is the Norway spruce fir (*Pinus abies*), or else they are sawn from Canada deal. The sawn laths are a modern introduction, due to the development of steam sawmills in Canada, which thus use up the small portions of the lumber. Laths are used for nailing to the uprights of partition-walls and to the rafters of ceilings; they are placed slightly apart to receive the plaster, which, by being pressed into the intervals, is retained, and when dry is held securely on the wall. Slaters' laths are longer strips of wood, nailed on to the framework of the roof, for the purpose of sustaining the slates, which are fastened to the laths by nails.

Lathyrus. See SWEET-PEA.

Latifundia. See AGRARIAN LAWS.

Latimer, HUGH, Protestant martyr, was born at Threaston, near Leicester, about the year 1485. 'My father,' he tells us, 'was a yeoman, and had no lands of his own; only he had a farm of three or four pound by year at the uttermost, and hereupon he tilled as much as kept half a dozen men. He had walk for a hundred sheep; and my mother milked thirty kine. He kept me to school . . . and was as diligent to teach me to shoot as to learn me any other thing.' An only son, Hugh was sent at fourteen to Cambridge, in 1510 (while still an undergraduate) was elected a fellow of Clare, and, having taken orders some nine years before, was in 1523 appointed a university preacher. In 1524 for his B.D. thesis he delivered a philippic against Melancthon, for he was, in his own words, 'as obstinate a papist as any in England.' Next year, however, through much talk with Bilney (q.v.), he 'began to smell the Word of God, forsaking the school doctors and such fooleries,' and soon becoming noted as a zealous preacher of the reformed doctrines. The consequence of this new-born zeal was that many of the adherents of the old faith were strongly excited against him, and he was embroiled in controversies. The question of the divorce brought Latimer more into notice. He was one of the Cambridge divines appointed to examine as to the lawfulness of Henry's marriage, and he declared on the King's side. This secured him the royal favour, and he was made chaplain to Anne Boleyn and rector of West-Kington in Wiltshire. In 1535 he was consecrated Bishop of Worcester; and at the opening of Convocation on 9th June 1536 he preached two powerful sermons urging the work of reformation. After a while that work rather retrograded than advanced, and Latimer found himself with his bold opinions in little favour at court. He retired to his diocese, and laboured there in a continual round of teaching, preaching, exhorting, writing, correcting, and reforming, either as ability would serve or the time would bear. This was his true vocation; he was an eminently practical reformer. Twice during Henry's reign he was sent to the Tower, in 1539 and 1546, on the former occasion resigning his bishopric. At Edward VI.'s accession he contemptuously declined to resume his

episcopal functions, but devoted himself to preaching and practical works of benevolence. The pulpit was his great power, and by his stirring, homely sermons he did much to rouse a spirit of religious earnestness throughout the land. At length by Edward's death (1553) he was stayed in his course of activity. In April 1551 he was examined at Oxford, and committed to Bocardo, the common gaol there, where he lay for more than a twelvemonth, feeble, sickly, worn out with his hardships. In September 1555, with Ridley and Crammer, he was brought before a commission, and after an ignominious trial was found guilty of heresy and handed over to the secular power. On 16th October he was burned with Ridley opposite Balliol College, exclaiming to his companion, 'Be of good comfort, Master Ridley, and play the man; we shall this day light such a candle by God's grace in England as I trust shall never be put out.'

Latimer's character presents a combination of many noble and disinterested qualities. He was brave, honest, devoted, and energetic, homely and popular, yet free from all violence; a martyr and hero, yet a plain, simple-minded, unpretending man. Humour and earnestness, manly sense and direct evangelical fervour, distinguish his sermons and his life, and make them alike interesting and admirable.

His sermons, letters, &c. were edited, with a memoir, by the Rev. G. Elwes Corrie (2 vols. 1844-45). See also Tulloch's *Leaders of the Reformation* (1859); and the Lives by Gilpin (1755), the Rev. R. Demaus (1869), and R. M. and A. J. Carlyle (1900).

Latin Empire, the name given to that portion of the Byzantine empire which was seized in 1204 by the Crusaders, who made Constantinople their capital. It was overthrown by the Greeks in 1261. See BYZANTINE EMPIRE.

Latin Language and Literature. Latin is one of the members of the Aryan or Indo-European family of languages. In ancient Italy several languages were in use; of which the Etruscan, spoken in Etruria (q.v.), and the Iapygian, spoken in the south-east of the peninsula, were non-Aryan, and very distinct from one another and from all the other Italic tongues. The latter fall into two main groups: the *Umbro-Sabellian*, including Umbrian, Oscan or Samnite, and Sabine; and the *Latin*, spoken in Latium, and probably at one time in Campania and Lucania, afterwards partly Hellenised. This Italic group seems to have had closer affinities with the Celtic tongues than with Greek (see GREECE, Vol. V, p. 381). For the relation of the Italian tribes to one another, see ROME. Latin was the language of Rome. The growth of Rome led to the dominance of the Latin over the others; and under Greek influence Latin became a great literary tongue.

Latin has played a great part in the history of language, entering largely, as it did, after Rome's conquests into the dialects of Spain and Gaul, countries thoroughly permeated by Roman life and civilisation. The Romance languages are built up on Latin, are indeed Latin in a new dress. Italian may be described as modern Latin; French and Spanish, the latter especially, are based mainly on Latin; and English, of course, has borrowed largely from Latin. (See ROMANCE LANGUAGES, the relevant sections on the Italian, French, Spanish, and other Romance tongues, and ENGLISH LANGUAGE.)

Latin reflects admirably the leading characteristics of the Roman people. It is the language of a practical, hard-headed people, who felt themselves called to rule, to give laws, and to establish order. Virgil's famous verse, 'In regere imperio populos, Romane, memento' (*Æneid*, vi. 852), happily expressed the genius of Rome. Latin, it has been said, is the voice of Empire and of Law;

it suits history, politics, jurisprudence, the business of the law-court, but it is not pliant or flexible enough to lend itself to the subtleties of philosophical speculation or to the refinements of the highest poetry. Horace, with all his skill, evidently found, in the composition of his odes, that Latin did not run very easily into a lyric mould.

Of literature, properly so called, there was nothing at Rome till the 3d century B.C. It then took the form of annals; we can hardly dignify it with the name of 'history.' These annals were, in part at least, based on old family chronicles, which the conservative spirit of the Romans jealously guarded. Family life in the great houses of Rome was intensely strong; a funeral was always a very solemn and impressive ceremony, and was never complete without an oration commemorating the merits of the deceased man. These orations, or at any rate the heads of them, were committed to writing and treasured in the family archives, and in them the annalists of the 3d century B.C. found their materials. The early history of Rome would, in fact, be made up of the memorials of a few noble families. The systematic treatment of it was undertaken towards the close of the 3d century by Fabius Pictor and Cincius Alimentus, who, however, wrote in Greek, feeling no doubt that as yet Latin was hardly equal to the demands of literary composition. The famous Marcus Porcius Cato, the Censor, as he was styled, who had fought in the great war with Hannibal, and who lived on into the middle of the 2d century B.C., seems to have been the father of Latin prose. His history of his own time, and his *Origines*, in which he discussed the origin of Rome and of some other cities of Italy, were the first important works written in the Latin language. Only a few meagre fragments have come down to us.

Contemporary with these men were two poets, Naevius and Ennius—metrical annalists we may call them—who gave the Romans histories in verse of the first and second Punic wars. Naevius wrote in the old native Italian metre—Saturnian, as it was termed; Ennius (half a Greek by birth) introduced the Greek hexameter. With these two poets, both men of considerable genius, Latin literature made a decided advance. A few poor fragments of their works are still extant, sufficient to show that they accepted the current legends and traditions about the origin of Rome.

Side by side with these essays in epic poetry there grew up a dramatic literature, to which Ennius and Naevius also contributed. This arose in the 3d century B.C. out of rude old Italian stage representations connected with popular festivals, and from a growing acquaintance with Greek culture, which by this time was widely diffused throughout Italy. The rough Latin humour, not much better than a sort of horseplay, could not evolve anything that deserved to be called the drama till it had come into contact with Greek art. The first play is said to have been exhibited on a Roman stage under the superintendence of Livius Andronicus, a Greek from Tarentum, whom we may regard as the father of Roman dramatic poetry. From that time the theatre became a recognised institution among the Romans. The plays of Andronicus were adaptations, almost translations, from the Greek; for the most part they seem to have been clumsy, inartistic performances. Still, they were popular and very widely circulated, and gave the Romans a decided taste for theatrical entertainments. Ennius and Naevius improved on them; nor did they confine themselves to a servile imitation of the Greeks, but aspired to build up a truly national drama, taking their subjects from old Roman legends or even from the history of their time. Tragedy as well as comedy, though never

equally popular, now took its place at Rome. Through Ennius more especially the rather questionable moral influence of the clever and subtle Euripides, with its cosmopolitan and denationalising tendencies, filtered down into the Roman mind, with the result of somewhat weakening the fibre of Roman character. Of Roman tragedy, however, we know but little; sensational horrors seem to have been peculiarly attractive, fostering perhaps the vile taste which subsequently found its gratification in the gladiatorial combats. Of comedy the chief and to us the best known representative is Plautus, deservedly a most popular poet with the Roman people, as his twenty extant plays testify, full as they are of original humour, of bright, witty dialogue, and funny, laughable incidents. Plautus, it seems, was exhibiting his plays in the latter part of the 3d and the early years of the 2d century B.C. Terence followed at no distant interval; six of his comedies which have come down to us show that a rather more refined and cultivated taste was coming into fashion. There is something of a modern tone and flavour about Terence. He is a pleasing, graceful writer, without, however, much originality; he in fact did little more than reproduce Greek comedies, especially those of Menander.

There was another branch of literature alongside of the drama, distinctively Roman, so that Quintilian (x. 1, 93) says of it 'it is all our own.' This was satire—'satura,' as the Romans called it—by which they seem to have meant both a sort of rude dramatic medley or miscellany, and a string of reflection, in a poetical form, on mankind and the world in general. Indeed all poetry that could not be classed as epic or dramatic came under the head of satire. There was nothing necessarily satirical in our sense about it. Ennius was a writer of 'satires' in the old meaning of the phrase; but it was Lucilius, in the latter half of the 2d century B.C., who introduced what we understand by 'satires,' and prepared the way for Horace and Juvenal. It was from the poets of the old Greek comedy, from Aristophanes, Eupolis, and Cratinus, that he borrowed the idea of political satire, in which, it seems, he allowed himself the utmost freedom. The public men of the day were the subjects of his attacks, and he lashed them, it is said, with merciless severity. His versification was rough, but he was undoubtedly a man of real wit and genius. We have unfortunately only a few scraps of his poetry.

Prose literature was but poorly represented in the 2d century B.C. by a few inferior historians, or rather annalists, of whom Cicero and Tacitus express a very mean opinion. They seem to have been utterly uncritical chroniclers, ridiculously pretentious, and always straining after rhetorical effect. In the early part of the 1st century was a historian of some merit, Sisenna, who described the social war and the civil wars of Marius and Sulla. Cicero speaks of him with considerable praise (*Brutus*, 64), and Sallust (*Jugurtha*, 95) says that in his treatment of the period of Sulla he was a careful and painstaking writer.

In the 1st century B.C. Roman literature made a great advance. A man of prodigious learning and industry, Marcus Terentius Varro, poured forth a multitude of works on every variety of subject, discussing agriculture in a treatise which has come down to us, and philology, grammar, and antiquities in elaborate dissertations which are unhappily lost. Varro, too, was a prolific writer of 'satires,' which in his case seem to have taken the form of moral and philosophical essays, more or less resembling the papers in the *Rambler* and *Spectator*, or Cicero's short dialogues on 'friendship' and 'old age.' Varro's heart was with the old life of Rome, and he liked to

ridicule the new lights and Greek philosophy, then becoming fashionable. Indeed he was a witty and lively satirist, as we may see from our extant fragments, and he must certainly have been one of the very first of Roman men of letters, a profound student and a clever essayist.

Cicero was ten years junior to Varro. It was the aim of his life to create a perfect prose style, and in this he has generally been regarded as successful. As head of the Roman bar he was accepted as an arbiter of finished composition and of correct taste. His speeches were published after careful revision as political pamphlets. In his numerous philosophical works he dexterously adapted Latin to Greek thought and speculation, achieving with considerable success a difficult work which had hitherto been but very imperfectly accomplished. The general verdict on him is, and as far as we can see will always be, that he was a consummate artist in style, if not a deep or fruitful thinker.

In poetry, in the first half of the 1st century, there was a new departure, a school which formed itself on the model of the Greek fashionable poets. At the head of this movement stands Catullus, the first to naturalise Greek lyric metres at Rome, a man of genuine poetic feeling and with true pathos. There is a more hearty ring about his poetry than in the more elaborate odes of Horace. Catullus had a touch of genius as well as scholarship and culture. His poems—the coarse ones too, it must be feared—accurately reflect the tone of gay Roman fashionable society. A widely different poet was the earnest and philosophical Lucretius, who in his *De Rerum Natura* puts the doctrines of Epicureanism, acceptable no doubt to many of his contemporaries, into the dress of hexameter verse, in which he considerably improved on Ennius. There is a stateliness if not much grace about the hexameters of Lucretius. The subject-matter of his work is decidedly unpoetic, but the genius of a poet makes itself felt in several passages. In the midst of a dreary wilderness are many beautiful spots and resting-places.

The later part of the 1st century was the great age of Roman poetry, the age of Virgil, Horace, and Ovid, familiar names throughout the whole civilised world. The fact that we happily possess their works entire is a proof of the high estimation in which they were held. Much of what is best in modern poetry is distinctly traceable to their inspiration. It has been the fashion to speak of this period as the Augustan age.

Virgil (70 B.C.), said to have been a great admirer of Lucretius, to whom he was evidently indebted, has the special merit of having brought Latin hexameter verse to exquisite perfection. There are no hexameters in the whole range of Latin poetry to compare with those of Virgil. His peculiar charm lies in a nice subtlety and refinement of expression, which makes the work of a translator almost hopeless. Every scholar recognises the great difficulty of Virgil. His *Pastorals* (*Bucolics*) and his four *Georgics*, poems on the various phases of agricultural life, and written, it would seem, to stimulate a healthy taste for rural pleasures, were direct imitations of Greek originals. Along with minute descriptions of farming operations, which he forces into verse with extraordinary ingenuity, are beautiful and highly poetic episodes—as, for instance, when he sings the praises of the farmer's life by way of conclusion to his second *Georgic*, or tells the tale of Orpheus and Eurydice in the fourth and last of these poems. In his *Æneid* he imitates Homer; here he writes with the definite purpose of stirring Roman patriotism, tracing back Rome's origin to Troy and to the gods, while he seeks to please Augustus by suggesting a comparison between him and the Trojan hero Æneas.

Virgil stood high in the emperor's favour, and rose from the rank of rather a small country squire to a foremost place in the great fashionable world of Rome.

Horace (65-8 B.C.) was a man of very humble origin, the son of a father who had been a slave, but he received a liberal education, which his natural genius enabled him to turn to good account. His *Odes* are to a great extent imitations of Greek lyric poetry, his metres are borrowed from the Greek; still there is much that is truly original in them, much that is distinctly Roman, and there is an indescribable charm about the exquisite finish of the language. Their peculiar grace and beauty, which to all Latin scholars are most delightful, seem to evaporate even in the most skilful translations. In his satires and epistles, the most popular of his writings, because so full of homely common sense and a pleasant, genial humour, there is a charming lightness of touch, an easy natural style and manner which perhaps have never been equalled. His laugh has no bitterness; of satire in one sense there is next to nothing in these amusing essays. 'The terseness of his language,' it has been well said, 'is that of a proverb, neat because homely.' Like Virgil, whose friend he was, Horace enjoyed the favour of Augustus.

Ovid (43 B.C.-18 A.D.) is the most voluminous of the Roman poets, and his facility in poetic composition seems to have been absolutely boundless. His verse is a marvel of cleverness and ingenuity. His great poem, the *Metamorphoses*, is a collection of mythological stories, turning on the change of men and women into animals, trees, plants, or flowers. His *Fasts* or *Roman Calendar*, a sort of poetical almanac, abounding in well-told stories of old Rome and her heroes, is on the whole pleasant reading. His love poetry, on which he specially prided himself and no doubt took great delight, are very bright and playful, in style and expression almost perfect, but they have not much depth of sentiment, and here and there they are so sensuous as to be positively offensive. One can well understand how it was said of him that he corrupted the morals of the youth. He has been fairly well described as the poet of fashionable society. From some cause unknown to us he was forced to end his days in a sort of Siberian exile on the shores of the Black Sea.

Two poets, writers of elegiac verse, contemporaries of Ovid, deserve a passing mention—Propertius and Tibullus: the first learned, pedantic, and obscure, yet often rising with true poetic fervour into a manly dignity and nobleness of thought; the latter sweet and tender, with a decided tinge of melancholy, the melancholy of a Roman who resigned himself to what he regarded as the fallen fortunes of his country, and who deliberately kept aloof from the imperial court. Tibullus was the friend of Horace and Ovid.

Prose-literature in the 1st century B.C. was represented by Cæsar, Sallust, and Livy. The great Cæsar wrote the history of his campaigns in a style admirably suited to the subject-matter, and recognised by all scholars as a specimen of the best and purest Latinity. Sallust (86-34 B.C.), whom we know through his narratives of the Catiline conspiracy and the war with Jugurtha, modelled himself on Thucydides, and like him aimed at a philosophical treatment of history. As yet Rome had had mere annalists; in Sallust she found a man who really deserved to be called a 'historian.' Of his *Histories*, a work which is said to have treated of the period immediately following Sulla's death, we have but fragments.

Livy (59 B.C.-19 A.D.) was simply a man of letters, taking no part in politics. His great work, the history of Rome from the beginning down to

9 B.C., the year of the last campaign of Drusus in Germany, and of his death, written during the reign of Augustus, with whom he was on friendly terms, though himself a republican, was comprised in 142 books, of which we possess 35, the last of these bringing us down to 167 B.C., the year of the annexation of Macedonia as a province to Rome. Livy's treatment of his subject evidently became fuller and more detailed as he approached his own time. Hence the loss of his later books is irreparable. As it is, we have not adequate material for a thorough history of Rome in the 1st century B.C. Livy's style is all that can be desired, bright and lively, as picturesque as that of our own Macaulay, but he is not a learned or critical writer; he wrote for the public generally, not for scholars or antiquaries; his aim in fact was to popularise the history of Rome and to magnify her empire, not to sift the legends which had gathered round her origin and early growth.

The last years of Augustus, and indeed most of the 1st century A.D., were, as regards literature, almost a barren desert: no poetry of any account, no forensic oratory, which under the empire had little scope, and no history. With Domitian, the last of the Caesars (81-96 A.D.), came a revival of letters, the silver age of Latinity, as it has been called, marked by the names of Juvenal, Tacitus, Pliny the Younger, and Quintilian. Under Nero indeed there had been a few minor lights in literature: the satirist Persius, spirited and dramatic, but obscure and affected, reminding one here and there of Browning; Lucan, author of a poem once read in schools and universities, describing under the title *Pharsalia* the civil war of Caesar and Pompey; and Seneca, whose numerous essays on morals and philosophy, embodying as they do what was best in Stoicism, have much of a modern, even of a Christian, tone. To these we may add the witty epigrammatist Martial and the learned and laborious Pliny the Elder (23-79 A.D.), in whose *Natural History* we have a comprehensive work on geography, botany, zoology, medicine, with attempted explanations of every kind of natural phenomena. A compilation rather than an original work, it is very useful as giving us an insight into the physical philosophy of the ancient world.

Juvenal's satires—satires in our sense of the word, bitter and savage—were published in the early part of the 2d century A.D., under Trajan and Hadrian. The man's honest indignation against the vulgar rich and the cringing tribe of parasites and fortune hunters, with which Rome swarmed, has our hearty sympathy, and it is expressed in pure, vigorous Latin. Johnson has imitated two of his satires in his *London* and his *Faculty of Human Wishes*.

The most conspicuous literary figure of the age was the great historian Tacitus, who was not, like Livy, a man of letters and nothing more, but who was practically acquainted with public life, and had distinguished himself at the Roman bar. An undertone of satire runs through his writings, which at many points remind us of Carlyle. He sums up a character with a few trenchant epithets, and throws out reflections which have passed into proverbs. There is perhaps no ancient author who has supplied more material for the modern essayist and historian. His concise and nervous style at once arrests the reader, and again and again demands from him a very considerable mental tension. His life of his father-in-law, Agricola, governor of Britain under Domitian, a masterpiece of biography, was written in 98 A.D.; so too was his *Germany*, a description of the native population of that country, with a sketch of its geography—a subject which must have been interesting to Romans who knew how little impression their arms had made

on those wild regions. In his *Annals* and *Histories*, much of which has been unfortunately lost, he describes the period from the accession of Tiberius to that of Nerva (14-98 A.D.). All that remains to us is his history of the reigns of Tiberius, Claudius, Nero in part, Galba, Otho, Vitellius, and of the rise of Vespasian. His *Histories*, as he termed the memoirs of his own time, were evidently written with great fullness of detail, and the loss of the later books is much to be deplored. In these we should have had a minute and trustworthy narrative of the three last Caesars, and of the better time which began with the brief reign of Nerva. Suetonius, a writer of the same period, the author of biographies of the twelve Caesars, which have come down to us, supplies but very poorly our deficiency.

With Tacitus we may couple his intimate friend, Pliny the Younger, as he is known in contradistinction to his uncle, whom we have already mentioned. The name is generally familiar as that of the man who as the governor of a Roman province in Asia Minor came into collision with the early Christians, and gave his opinion of them in a letter to the Emperor Trajan. Pliny's letters, dealing as they do with every variety of topic—politics, literature, art, society, with glimpses into his home-life and descriptions of his villas—and written, too, in a pleasing style of good Latinity, rank among the best literary specimens of the period. They are of special interest as illustrating aspects of Roman life which would otherwise be unknown to us.

A work also of great merit has happily come down to us from the pen of an eminent professor of rhetoric, Quintilian, who is said to have numbered Pliny among his pupils. It is a treatise on rhetoric and kindred subjects, written in the reign of Domitian, discussing with deep learning and sound critical taste the whole subject of education, and concluding with a short sketch of Greek and Roman literature in its special connection with oratorical training. Scholars have always admired its diction.

Latin literature is from this time almost a blank, represented only by a few feeble writers whose names are not worth noting in a brief summary. The age of what we call classical Latin was finally over. Petty rhetoricians and epitomisers alone survived. Coming down to the close of the 4th century A.D., the period of the Emperor Theodosius (the first of that name), we light on a writer who has been described as 'the last subject of Rome who composed a profane history in the Latin language,' Ammianus Marcellinus, the historian of the period from 96 to 378 A.D. Rather more than the half of his work is extant; in this we have a full account of the reigns of Julian, Jovian, Valentinian I. and II., and Valens—in all twenty-five years of the history of which he had a personal knowledge. He is a good, useful writer, but hardly a man of letters. The last of the classic poets, Claudianus, flourished about the same time.

In the last years of the 5th and the first half of the 6th century A.D. lived the learned Boethius, whose work on the consolation to be derived from philosophy (*De Consolatione*) was translated by King Alfred. There is something of a mystery about Boethius: whether he was a Christian or half-heathen philosopher is uncertain; he seems to have hovered on the borderland between the rising and the decadent belief.

Latin was now the language of the Christian church of the West, and the Vulgate the current version of the Scriptures; in Latin, more or less cultured, were written the works of the Latin Fathers, of the theologians and thinkers of the middle ages; sonorous Latin hymnology with rhyming metres grew up; and Latin remains still the language of the services in the Catholic Church. Learning and literature almost died out for

centuries, the period we call the dark ages. Latin in its fusion in the Celtic and Teutonic dialects was quite losing its distinctive character, although it is true that Rome imposed not only her yoke but her language on Spain and Gaul; still, as regards language, her victory was won with heavy loss. The grammar and syntax indeed were to a great extent retained; but, with the introduction of the definite and indefinite articles, of the auxiliary verb, the addition of a number of words from the barbarians, and the utter disregard of quantity in pronunciation, Latin underwent a complete change, and was at last transmuted into its derivatives, the Romance languages. In its corrupted form, however, it was for a long period a living language, but it ceased to be so in the 10th century. With the revival of letters in the 15th and 16th centuries Latin recovered itself; Ciceronianism became the fashion, Erasmus being one of its most eminent representatives. Latin for the time established itself as the recognised medium of communication in the learned world; and almost all books of any importance, theological and scientific treatises, were written in that language. The controversial works of the English and Swiss reformers were written in Latin; so were the works of Bacon, and Newton's *Principia*—to quote but a few examples. In the universities professors lectured in Latin; candidates for degrees disputed in Latin theses; the grace before and after meals was in Latin—a usage still surviving at Oxford and Cambridge and in the Inns of Court. Notes to editions of the classics, both critical and explanatory, were always in Latin; and Dr Arnold thought it necessary to apologise in the preface to his *Theoglyphes* in 1830 for deviating from the universal practice. It was indeed a true instinct which assigned the Latin language a principal place in our schools and universities. Not only is it the key to a most important literature, but it throws infinite light on the history of language in general, as well as on the particular languages of modern Europe. Hence it is an admirable instrument of mental discipline.

See the articles in this work on the several Latin authors referred to; those on ALPHABET, ARYAN RACE, DRAMA, CHURCH HISTORY, FATHERS OF THE CHURCH, GRAFFITI, HYMNS, INSCRIPTIONS, PHILOLOGY, RENAISSANCE, ROME, ROMANCE LANGUAGES; the grammars of Roby, Kennedy, Madvig, Kühner, Stolz and Schmalz; the German works on the history of the language and literature by Bahr (new ed. 1873), Bernhardt (1872), Munk (new ed. 1881), Touffet, trans. 1873; German 5th ed. 1800); Simcox's *History of Latin Literature from Ennius to Boethius* (1883); Cruttwell's *History of Roman Literature* (1879); Brown's *History of Roman Classical Literature* (new ed. 1884); Sellar's *Roman Poets of the Republic* (new ed. 1881) and of the *Augustan Age* (new ed. 1884); Wilkins's *Prætor*; Tyrrel's *Latin Poetry* (1895); and Mackail's *Latin Literature*. Mayor's *Bibliographic Clue to Latin Literature* (1875) is based on Hubner. See also W. M. Lindsay, *The Latin Language, a Historical Account of its Sounds, Syntax, and Phrasing*.

Latin Union. See BELL-FALLISM.

Latitude and Longitude. in Geography, denote the angular distances of a place on the earth from the equator and first meridian respectively. The latitude of a place is the angle subtended at the centre of the earth by the arc of the meridian from the equator to the place in question. The longitude of a place is the angle at the earth's axis between the plane of the first meridian and that of the meridian of the place. Latitude is reckoned from the equator to the poles, the equator having 0 lat., and the poles 90° N. and 90° S. respectively. Longitude is reckoned along the equator or along a parallel of latitude from the first meridian; but as nature has not in this case supplied us with a fixed starting-point, it is necessary to fix upon one in an arbitrary

manner. Cardinal Richelieu in the 17th century proposed to use the meridian of Ferro, one of the Canary Isles, for this purpose, as this meridian lay to the west of all the Old World and to the east of America. The Arab geographers had also reckoned longitude from the 'Fortunate Isles.' For convenience the meridian of Ferro was subsequently reckoned as exactly 20° W. of Paris, and thus lost its independent character. The meridian of Greenwich came into widest use, being universal as the zero of longitude in sea-charts and in the land maps made in the United Kingdom and the United States. Large scale maps of the United States are usually marked with longitudes west from Greenwich and also the number of degrees from Washington. One set of engraved meridians serves for this purpose, as Washington lies 77° W. of Greenwich. By the decision of a conference of delegates from almost all the civilised countries in the world, held at Washington in 1884, the meridian of Greenwich was accepted as the universal prime meridian, from which longitudes were measured to + 180° (or 180° E.) and - 180° (180° W.); the French delegate dissented, and in France maps are still drawn to the prime meridian of Paris, although reference marks to Greenwich longitude are now usually added. On German maps the meridian of Berlin was sometimes employed, in Italian maps that of Rome, and in Russian maps that of Pulkova Observatory (St. Petersburg) is still commonly used together with that of Ferro.

The determination of both latitude and longitude depends upon astronomical observation. The principle on which the more usual methods of finding the latitude depend will be understood from the following considerations: To an observer at the earth's equator the celestial poles are in the horizon, and the meridian point of the equator is in the zenith. If now he travel northwards over one degree of the meridian the north celestial pole will appear one degree above the horizon, while the meridian point of the equator will decline one degree southwards; and so on, until, when he reached the terrestrial pole, the pole of the heavens would be in the zenith, and the equator in the horizon. The same thing is true with regard to the southern hemisphere. It thus appears that to determine the latitude of a place we have only to find the altitude of the pole, or the zenith distance of the meridian point of the equator (the complement of its altitude). The method most usual with navigators and travellers is, by means of a sextant, to observe the meridian altitude of a star whose declination or distance from the equator is known; or of the sun, whose declination at the time may be found from the *Nautical Almanac*; the sum or difference (according to the direction of the declination) of the altitude and declination gives the meridian altitude of the equator, which is the co-latitude, i.e. when subtracted from 90° leaves the latitude.

The determination of the longitude is less easy, and long presented insuperable practical difficulties. All methods depend on measuring the difference between local time and the time of the first meridian, which, reduced to degrees (at the rate of 360° per day, or 15° for every hour, or 1° for 4 minutes), gives the longitude. Eclipses of the sun, moon, or Jupiter's satellites, occultations of fixed stars by the moon, the time occupied in the moon's transit over the meridian, &c. are occurrences the exact period of which are calculated in advance in Greenwich time. When one of these phenomena is observed the true Greenwich time can at once be obtained from the *Nautical Almanac*, and the local time from direct observation is the only other datum required. The longitude of stations on land connected by telegraph with an observatory

is most readily and accurately determined by an exchange of time signals; the exact position of every observatory is always ascertained to a high degree of accuracy by repeated observations of celestial phenomena. The two methods in use among travellers and on board ship are remarkable for their combination of simplicity with accuracy. The first and most common consists merely in determining at what hour on the chronometer (which is set to Greenwich time) the sun crosses the meridian. If, when the sun is on the meridian, at the place of observation, the chronometer points to 3 hours 52 minutes, the difference of longitude is 58', and the longitude will be W., as the sun has arrived over the place *later* than at Greenwich; similarly, if the sun be over the meridian of a place at 9 hours 40 minutes A.M., the longitude is 35° E. (by the chronometer). The accuracy of this method depends evidently upon the correctness of time-keepers (see HOROLOGY). The other method—that of 'lunar distances'—is much used at sea in order to check the results of chronometer measurements, and may be thus explained: The angular distance of the moon from certain fixed stars is calculated with great accuracy (about three years in advance) for every three hours of Greenwich time, and published in the *Nautical Almanac*. The moon's distance from some one star having been observed, and corrected for refraction and parallax, and the local time having also been noted, the difference between this local time and *that time in the table which corresponds to the same distance* gives the longitude. When applied to a heavenly body, the terms latitude and longitude have the same relations to the ecliptic and its poles, and to the point on the ecliptic called the Equinox (q.v.), that terrestrial latitude and longitude have to the equator and a first meridian. The positions of a heavenly body relatively to the equator are called its Declination (q.v.) and Right Ascension (q.v.). See also DEGREE.

Latitudinarians, a name applied by contemporaries to a school of theologians within the English Church in the latter half of the 17th century. It grew out of the earlier movement in favour of a more liberal constitution for the church, represented by the names of Falkland, Hales, Jeremy Taylor, and Chillingworth. This earlier movement was mainly ecclesiastical, aiming at a wider extension of the Anglican Church system; the later was mainly philosophical, and had still more directly in view the interests of rational religion. The school was represented by a succession of well-known Cambridge divines, of whom the chief were Whichcote, Smith, Cudworth, and More. Starting from the same ground as Hales and Chillingworth, in the disregard for authority and tradition in matters of faith, and the assertion of the supremacy of reason as the test of truth, their liberalism takes a higher flight, and brings us to the discussion of larger questions and principles of a more fundamental and far-reaching character. The Cambridge divines, nurtured on Plato and the later Platonists, sought to wed philosophy to religion, and to confirm the union on an indestructible basis of reason. This was the first attempt to link together philosophy and Christianity ever made by any Protestant school; and, indeed, the first true attempt since the days of the great Alexandrine teachers to construct a philosophy of religion at once free and conservative, in which the rights of faith and the claims of the speculative intellect should each have free scope and blend together for mutual elevation and strength.

See the articles on CHILLINGWORTH, FALKLAND, HALES, SMITH, &c.; and Principal Talbot's *Rational Theology as Englished in the Seventeenth Century* (2 vols. 1872).

Latium. See ROME.

Latona, or LETO. See APOLLO.

Latour d'Auvergne. THEOPHILE MALO CORRET DE, dubbed by Napoleon 'First Grenadier of the Armies of the Republic,' was born, 23d November 1743, at Calvaix in Finistère, of an illegitimate branch of the family of the Dukes of Latour d'Auvergne. He enlisted as a musketeer in 1767, and distinguished himself at the siege of Fort Mahon in 1782. But he steadily refused advancement in military rank, and was killed, a simple captain, on 28th June 1800 at Oberhausen, near Neuburg in Bavaria. His remains were carried to Paris and interred in the Panthéon on 4th August 1889. French biographies are full of instances of his daring valour, his Spartan simplicity of life, and his chivalrous affection for his friends. When he died the whole French army mourned for him three days; his sabre was placed in the church of the Invalides at Paris; and every morning, till the close of the empire, at the muster-roll of his regiment his name continued to be called, and the senior sergeant answered to the call: '*Mort au champ d'honneur*' (Dead on the field of honour). Latour d'Auvergne was also a respectable student of languages, and wrote *Recherches sur la Langue, l'Origine, et les Antiquités des Bretons* (1792). See Lives by Buhot de Kersers (1874) and Simond (1895).

La Trappe. See TRAPPISTS.

Latreille. PIERRE ANDRÉ, French naturalist, was born, 29th November 1762, at Brives, in the department of Corrèze. Though he completed his education for the church, he gave himself chiefly to entomological studies. In 1798 he was commissioned to arrange the entomological collections in the Museum of Natural History at Paris, and in 1830 was appointed to the chair of Natural History (along with De Blainville) in the same institution. He died at Paris on 6th February 1833. In 1796 he published his great work, *Précis des Caractères Génériques des Insectes*—an important step towards a truly natural system of entomology. The more important of his other works are the *Salicmoules* (1800), *Singes* (1801), *Crustacés et Insectes* (14 vols. 1802-5), *Reptiles* (1802), *Généra Crustacéorum et Insectorum* (4 vols. 1806-9), *Considérations sur l'Ordre Naturel des Animaux* (1810), *Familles Naturelles du Règne Animal* (1825), and *Cours d'Entomologie* (2 vols. 1831-33).

Latten (Fr. *laton*, 'brass'), a term specially applied to sheet-brass, but also used for sheet-tin and tinned iron-plate.

Latter-day Saints. See MORMONS.

Lattice Leaf, also called LACI LEAF, WATER-YAM, or OUYBRANDRANO (*Oucicandra fenestralis*), an aquatic plant belonging to the natural order Juncaginæ. It is best known as the lattice-leaf plant, from the singular resemblance of the leaves to open lattice-work. The plant is a native of Madagascar, and was introduced into England about 1850 by the Rev. W. Ellis. It grows on the margins of running streams in shallow water. The leaves grow in radiating clusters, and float immediately under the surface of the water; in outline they are oblong, rounded at base and point, from 9 to 12 inches long. Their peculiar structure is due to the absence of the cellular tissue which fills up the spaces between the nerves or veins of ordinary leaves, the veins, which in this instance are almost geometrically parallel longitudinally and transversely, being alone coated with cellular matter and parenchyma. The flower-stems rise to the surface of the water and there divide into two spikes of flowers, which are accompanied by conspicuous white bracts. The plant is not only curious but useful as an article of food to the

natives, who eat the yam-like roots. The native name of the plant is *Ouvirandra*, which means literally water-yam. There are several other species of *Ouvirandra*, but none so remarkable and interesting as the lattice-leaf plant, which is frequently to be seen growing in hothouses. See AQUATIC PLANTS for illustration.

Latude, HENRI MAZERS DE, prisoner in the Bastille, was born at Montagnac, in Languedoc, 23d March 1725. A young artillery officer, he sought to secure Madame de Pompadour's favour by revealing to her a plot to poison her. The plot was discovered to be of his own contriving, and he was sent to the Bastille in 1749. In spite of ingenious efforts to escape, he remained in prison till 1777, when he was released on condition of living in his native village. But having come to Paris again, he was imprisoned till 1784. At the Revolution he was treated as a victim of despotism; but he died forgotten, 1st January 1805. See the monograph by Thierry (1792; new ed. 1889).

Lauban, an ancient town of Prussian Silesia, on the Queiss, 15 miles by rail E. of Görlitz, carries on linen and cotton weaving, printing, bleaching, &c. Pop. (1895) 12,634. It was destroyed by the Hussites (1427 and 1431), and by the Swedes (1640).

Laud, WILLIAM, Archbishop of Canterbury, was born at Reading, a well-to-do clothier's son, on 7th October 1573. From Reading free-school, where he 'had the happiness to be educated under a very severe schoolmaster,' he passed at sixteen to St John's College, Oxford, of which four years later he was admitted a fellow. Ordained in 1601, he made himself obnoxious to the university authorities by his open antipathy to the dominant Puritanism; but his solid learning, his amazing industry, his administrative capacity, his sincere and unselfish churchmanship, soon won him both friends and patrons. One of these was Charles Blount, Earl of Devonshire, whom in 1605 Laud married to the divorced Lady Rich (an offence that ever weighed heavy on his conscience); another was Buckingham, to whom he became confessor in 1622, having a month previously disputed before him and the countess his mother with Fisher the Jesuit. Meanwhile he rose steadily from preferment to preferment—incumbent of five livings (1607-10), D.D. (1608), president of his old college and king's chaplain (1611), Prebendary of Lincoln (1614), Archdeacon of Huntingdon (1615), Dean of Gloucester (1616), Prebendary of Westminster and Bishop of St Davids (1621), Bishop of Bath and Wells, Dean of the Chapel Royal, and a privy-councillor (1626), Bishop of London (1628), Chancellor of Oxford (1630), and finally Archbishop of Canterbury (1633). That very week he received two orders of a cardinal's hat; but 'my answer,' he writes in his Diary, 'was that somewhat dwelt within me, which would not suffer that, till Rome were other than it is.'

Already, after Buckingham's assassination, he had virtually become the first minister of the crown, one with Strafford and Charles I. in the triumvirate whose aim was absolutism in church and state, and which thus stood opposed to Puritanism alike and democracy. Laud's task, a grateful one, was to raise the English Church to its rightful position of a branch, if a younger branch, of the Church Catholic, to root out Calvinism in England and Presbyterianism in Scotland. In the former country he drew up a list of 'Orthodox' and 'Puritan' ministers, whom, the wheat and the tares, he proceeded to separate by scolding, suspending, depriving. Freedom of worship was withdrawn from Wallon and French refugees; Englishmen abroad were forbidden to attend Calvinistic services; and

at home 'gospel preaching, justification by faith, and Sabbatarianism were to be superseded by an elaborate ritual, by the doctrine of the real presence, celibacy, and confession, and by the Book of Sports (q.v.)—changes rigorously enforced by the court of High Commission and the Star Chamber. Nor was a policy without result which checked the development of Puritanism within the Anglican communion; which raised up a school of such Laudian clergy as Cosin, Nicholas Ferrar, George Herbert, Juxon, Manwaring, Montague, and Wren; which has borne later fruit in the Nonjurors, the Tractarians, and the Ritualists; and which to-day has a standing memorial in every Anglican church throughout the world—the altar-wise position of the Holy Table. In Scotland it was otherwise. There the tentative effort made by James I. and Laud in 1617 to give back life to dead Episcopacy had merely failed. Laud's second attempt (1635-37), involving the thorough Anglicising of the Scottish Church, gave birth to the riot in St Giles', Edinburgh, that riot to the Covenant (q.v.), the Covenant to the 'Bishops' war,' and this in turn to the meeting of the Long Parliament, which on 18th December 1640 impeached the archbishop of treason, and ten weeks later sent him to the Tower. He would not escape (Grotius urged him to do so); and at last, after a tedious and complicated trial before a handful of peers, of whom never more than fourteen were present, and of whom the Speaker alone sat through the whole proceedings, after a defence that extorted praise even from Prynne, on 17th December 1644 he was voted 'guilty of endeavouring to subvert the laws, to overthrow the Protestant religion, and to act as an enemy to parliament.' The judges unanimously declared that this was not treason; but under an unconstitutional ordinance of attainder, and the gallows reluctantly commuted for the axe, he was beheaded on Tower Hill, 10th January 1645. He was buried first in the church of All-Hallows, Barking, and in 1663 translated to the chapel of St John's at Oxford.

To Heylin Laud is 'the holy martyr;' to Laud's accusers 'the great incendiary;' to Macaulay just 'a ridiculous old bigot.' To us he seems rather a typical college don, fussy, restless, high-handed, concerned about trifles, cold and unsympathetic, as little in mind as in person. Withal, he was childishly superstitious, his Diary teeming with omens and silly dreams, as 'Dreamed of the marriage of I know not whom,' and 'Dreamed of the burial of I know not whom, and waked sad.' Superstition, of course, was a failing of that age; so, too, was the chief sin of which Laud stands accused—intolerance. For if Laud cut off Puritans' ears, the Puritans cut off Laud's head. His great misfortune, indeed, was that he rose, like the parasite ivy, to eminence. Had he lived and died a college president, his waspishness would have long since lost its sting, and his memory survived only as that of the founder of the chair of Arabic, and a munificent benefactor of the Bodleian Library.

Of Laud's works, collected in the Anglo-Catholic Library (7 vols. Oxford, 1847-60), by far the most interesting is his Diary, which was published by Wharton in 1694. Peter Heylin, Laud's chaplain, first wrote his biography, *Cyprianus Anglicanus* (1668); and there are modern lives by Le Bas (1836), Mozley (1845; republished in *Essays*, 1878), Hook (*Lives of Archbishops*, 1875), A. C. Benson (1887), C. H. Simpson (1894), and R. H.utton (1895). See also the articles, with work there cited, on CHARLES I., STRAFFORD, CHILLINGWORTH, HALES, JEREMY TAYLOR, and PRYNNE.

Laudanum, or more correctly TINCTURE OF OPIUM, is the most generally used of all the preparations of opium. It is obtained by macerating the sliced or powdered drug in dilute spirit, and filtering.

It is of a deep brownish-red colour, and possesses the peculiar odour and smell of opium. One of the greatest objections to it is that it is liable to great variations of strength. When the tincture of opium is ordered a definite strength is always obtained, but under the name of *laudanum* various compounds are sold, and the former term should therefore alone be used. Laudanum is a powerful anodyne and soporific, but is more liable to cause headache than the solution of one of the salts of morphia. Its general action and its uses will be described in the article OPIUM. The dose for an adult varies from ten minims to a drachm. To children (as is the case with all opiates) it must be given with extreme caution. *Oscumium*, or about two drops, has been known to prove fatal to an infant. See POISON.

Lauder, a quaint little royal burgh of Berwickshire, on Leader Water, 25 miles S.E. of Edinburgh. Near it is Thirlestane Castle, the seat of the Earl of Lauderdale. Till 1885 it united with Haddington, &c. to return one member to parliament. Pop. 719. See JAMES III.; and for the town's immemorial tenure of Lauder Common, *Common's Village Communities* (1890).

Lauder, ROBERT SCOTT, subject and portrait painter, was born at Silvemills, near Edinburgh, in 1803, studied at the Trustees' Academy and in London, and in 1830 was elected a member of the recently founded Royal Scottish Academy. He lived in Italy and at Munich in 1833-38, and then chiefly in London till 1849, when he returned to Edinburgh. He died there, 21st April 1869. Among his best works are two portraits, 'Christ teaching Humility,' and 'Sentinels,' all in the National Gallery of Scotland; scenes from 'The Bride of Lammermoor,' 'The Trial of Eddie Deans,' and 'Meg Merrilies.' His brother, JAMES ECKFORD LAUDER, R.S.A. (1811-69), was also a subject-painter. His works include 'Hagar,' in the National Gallery of Scotland; 'The Unjust Steward,' and 'The Wise and Foolish Virgins.'

Lauder, SIR THOMAS DICK, Bart., was born in 1784, the eldest son of Sir Andrew Lauder of Fountainhall, Haddingtonshire. He served for a time in the 26th (Cameronian) regiment, succeeded to the baronetcy in 1820, and lived at the Grange, near Edinburgh, from 1831 until his death on 29th May 1848. For the last nine years of his life he was secretary to the Board of Manufactures and of Fisheries. Of Lauder's two romances, *The Wolfe of Badenoch* and *Lochavallon*, the former is still a popular book. His best works are not these, however, but his *Northshire Folds* (1830) and, especially, *Scottish Rivers*, which was appearing in *Tait's Magazine* when his death cut the series of papers short. His *Legendary Tales of the Highlands* (3 vols. 1841) may also be mentioned. In politics a Liberal, and of unwearied public spirit, Lauder was in private a lovable and accomplished gentleman. Lord Cockburn, who describes him as 'the greatest favourite with the mob that the Whigs have,' says: 'Lauder could make his way in the world as a player, or a ballad-singer, or a street fiddler, or a geologist, or a civil engineer, or a surveyor, and easily and eminently as an artist or a layer out of ground.' See Dr John Brown's preface to the reprint of *Scottish Rivers* (1874).

Lauderdale, JOHN MATTLAND, DUKE OF, who earned the detestation of his countrymen, was born at Leithington (now Lennoxlove), near Haddington, 24th May 1616, son of the first Earl of Lauderdale. In his youth he simulated ardent zeal for the Covenanting cause, and was actually one of the Scottish commissioners at the Westminster Assembly of Divines. He succeeded as second earl in 1645, was taken prisoner at Worcester in

1651, and confined nine years in the Tower. Before the Restoration he had gained the king's ear, and he now became Secretary of State in Scotland. He found the nobles impoverished and corrupt beyond all precedent, and for the first seven years he was engaged in an incessant struggle to maintain his place with rivals like Middleton as unscrupulous as himself, as well as with more open and honourable opposition from Clarendon and others in England. He made himself indispensable to Charles, who liked his clever and caustic wit, and felt no repugnance at his sensuality, his ribaldry and his drunken buffooneries; his slobbering mouth and heavy face brutalised by vice, as we see it still in Lely's portrait. His main object was to bring about the absolute power of the crown in church and state, and for this end he laboured with the most unceasing persistence, using patriotism, honour, and religion alike as mere pawns in his unscrupulous game. He was ever bold, full of resource, and quick to recognise the use to be made of such creatures as the brutal Rothies and the 'Andas' Sharp. His harsh measures gould the poor peasants of the west country into the rebellion of 1666, but the greater guilt of the Highland invasion during the winter of 1677 and the spring of 1678 lies on the shoulders of the bishops no less than of the ruthless Lauderdale. He formed a militia of 20,000 men ready to do the bidding of the king anywhere, and drilled the Episcopal Church into complete subservience. He was a member of the king's privy-council, had a seat in the famous Cabal ministry, and was created a duke in 1672. Fresh intrigues against him of the Scottish nobles, in concert with Shaftesbury in London, reached their height in 1674, but were foiled by his own ability in counter-plots and the king's personal regard for him. On the 7th May 1678 a vote was carried in the House of Commons for an address to the king praying for Lauderdale's removal from the royal presence for ever; but two days later, through lavish use of court intimidation and the Speaker's corrupt management of the forms of the House for procuring adjournments, the address when prepared was thrown out by a single vote. Another short struggle with Hamilton in the Convention of Estates left him again triumphant, and for two years more he held his power, until unable from infirmity to hold it longer, Lauderdale in his later life married the ambitious Lady Dysart, and it was alleged had cleared the way by hastening the death of his countess. He had but one daughter, and his dukedom died with him, while the earldom and family titles passed to his brother. He died, worn out by debaucheries and the anxieties of constant intrigue, at Tunbridge Wells, 20th August 1682, and eight months later was laid in the Abbey Church at Haddington, but not to rest, according to persistent popular tradition.

See two admirable articles together embracing his whole public career, by Osmond Ayr, in the *Quarterly Review* (vol. clvii. 1884) and the *English Historical Review* (vol. i. 1886), based on the 36 volumes of Lauderdale MSS. in the British Museum, each containing from 100 to 150 documents. A selection from these was edited by Mr Ayr for the Camden Society (3 vols. 1884-85).

Laudon. See LONDON.

Lauds. See BREVARY.

Lauenburg, of SAXE-LAUBENBURG, a German duchy, formerly united to the crown of Denmark, and lying on the right bank of the Elbe between Holstein and Mecklenburg. In the 12th century this district was conquered by the dukes of Saxony. In 1260 John I., son of Albert I. of Saxony, founded the ducal House of Saxe-Lauenburg. After the extinction of this line, it was inherited by the Duke of Brunswick-Celle in 1702,

and passed into the possession of the Hanoverian kings of Great Britain, was seized along with Hanover by the French in 1803, and afterwards, with some changes of boundary, was made over to Prussia, and by Prussia transferred to Denmark (1816), but with reservation of all rights and privileges. By the treaty of Gastein (1865) it came again into the possession of Prussia. It has an area of 457 sq. m., and (in 1885) 49,861 inhabitants, and is a well-cultivated and fertile country. In 1876 Lauenburg was finally incorporated with the province of Sleswick-Holstein, of which it is now a district. Prince Bismarck was offered, and accepted the title of Duke of Lauenburg on his retirement from office in 1890.—The town of Lauenburg, once capital of the duchy, stands on the Elbe, 25 miles SE. of Hamburg. It has a pop. of 4748. It contains the old ducal palace, dating from 1482.—LAVENBURG, in Pomerania, 38 miles NW. of Danzig, has flax and woollen spinning, iron-founding, and machine-making. Pop. 7214. It was originally a town of the Teutonic Knights (from 1322), then of Poland (1454-1657), and finally of Brandenburg.

Laughing Gas. See NITROGEN, and ANÆSTHESIA.

Laughing Jackass, or GREAT KINGFISHER (*Dacelo gigas*), a bird belonging to the Alcedinidae (see KINGFISHER), but in some respects an aberrant form. It has the general build of a kingfisher, but is not a fisher. It feeds upon insects, reptiles, and even small mammals. The peculiar hoot which it utters has, of course, given to it its name. It lays its pearl-white eggs in a hole in a gum-tree. There is another closely allied species (*D. leucii*), of identical habits: both birds inhabit Australia.

Launce. See EEL.

Launceston, till 1838 the county town of Cornwall, on the Kenesey, a tributary of the Tamar, 36 miles NW. of Plymouth and 50 W. of Exeter by branch-lines opened in 1865 and 1886. It has a handsome granite church (1511); the circular Norman keep of a castle which figured much in the Great Rebellion, and in which Fox the Quaker was imprisoned (1656); an old gateway; and a new town-hall (1887). A municipal borough since about 1227, Launceston returned two members till 1832, one till 1885. Pop. (1851) 3397; (1891) 4345. See A. F. Robbins, *Launceston, Past and Present* (Launceston, 1885).

Launceston, the second city of Tasmania, is to the north of the island what Hobart, the capital, is to the south—the chief port of entry and mart of trade. It stands in a valley enclosed by hills at the junction of the Esk with the Tamar, which, after a course of 40 miles, enters Bass Strait (q.v.) at Port Dalrymple. It is accessible to ships of considerable burden, and carries on a thriving commerce with the principal Australian ports, having steam communication twice a week with Melbourne, and with Sydney fortnightly. There is a railway (133 miles) to Hobart. The town is supplied with water from St Patrick's River, 15 miles E. The principal buildings are the government house, new post-office, convent, theatre, town-hall, and mechanics' institute with a library of 13,000 volumes. Launceston was incorporated in 1858, and raised to a city in 1889. Pop. (1881) 12,753; (1891) 17,208.

Launch, the largest boat belonging to a ship. For steam-launch, see BOAT; for the process of launching ships, see SHIPBUILDING.

Laura. See MONACHISM.

Lauraceæ, a natural order of exogenous plants, consisting of trees or shrubs which have leaves without stipules, and flowers in panicles or umbels. The perianth is 4-6-cleft; the stamens are

opposite to its segments, and twice as many. The fruit is a one-seeded berry or drupe; the fruit-stalk often enlarging and becoming fleshy. This order contains about 450 known species, mostly tropical. The Laurel (q.v.) is the only European species. An aromatic and fragrant character pervades the order, and amongst its products are cinnamon, cassia, and other aromatic barks, also a number of aromatic fruits somewhat resembling nutmeg (see NUTMEG). The timber of some species, as greenheart, is valuable; some are esteemed for their medicinal barks, as greenheart (bebeern) and sassafras; some for their secretions, of which camphor is the most important. *Oraculaphoe oqafira*, a South American tree, yields a camphoraceous volatile oil in great quantity if mere incisions are made in its bark. The fruit of some species is agreeable, as the Avocado Pear (q.v.). A very few remarkable species, forming the genus *Casyltha*, have been united with this order by many botanists, although others separate them as a distinct order. They are climbing parasites, like dodders, found in the woods of the hottest parts of the globe.

Laureate, POET, an official attached to the household of the English sovereigns. His early history is involved in some obscurity. In the *Domestic Book* we find one Berdie described as 'Joelaton Regis,' and a certain Roger or Raheus, king's minstrel, is said to have founded the monastery of St Bartholomew in Smithfield under Henry I. We read of Richard I. carrying William the Foreigner to Palestine to sing his exploits, and of Edward I. taking the Carmelite friar, Robert Baston, with him to Scotland in 1304. The latter apparently went also for the same purpose with Edward II. to Bannockburn, but was captured by the Scottish soldiers and forced to celebrate their prowess instead, as the price of his freedom. The badness of his verses (rhymed hexameters) was humorously ascribed by the next century Scottish writers to the unwillingness of his conscience. We read of one John Kaye attached to Edward IV. as versifier (*versificator*), and before this period we meet the term 'laureate' applied on the one hand to one who had earned the laurel wreath at one of the universities for rhetoric and versification in Latin, and on the other to any poet of surpassing merit. Skelton was one of the former, and proudly styled himself 'Poeta Skelton Laureatus' in the headings of his Latin poems; the term 'laureate poet' applied by Chaucer to Petrarch bears the latter sense. The first poet-laureate in the modern sense was Spenser, who was granted a pension of £50 by Queen Elizabeth in 1591; but the first who received the office by formal letters-patent was Ben Jonson. His salary was 100 marks, raised by Charles I. to the same number of pounds sterling, with the addition of a tierce of Canary. James II. was mean enough to discontinue the allowance of wine, but it was afterwards resumed, until commuted for £27 a year in the laureateship of Pye. It was long the duty of the poet-laureate to write an ode on the king's birthday—'his quit rent ode, his peppercorn of praise,' in Cowper's phrase; but this task fell into abeyance towards the end of the reign of George III. The list of poets-laureate preserves the memory of a few names else almost forgotten; but it contains Spenser, Ben Jonson, Dryden, Southey, Wordsworth, and Tennyson. The complete list, with the years of office, is as follows: Edmund Spenser (1591-99), Samuel Daniel (1599-1619), Ben Jonson (1619-37), followed by an interregnum until 1660; William Davenant, knight (1660-68), John Dryden (1670-89), Thomas Shadwell (1689-92), Nahum Tait (1692-1715), Nicholas Rowe (1715-18), Laurence Easden, clerk (1718-30), Colley Cibber (1730-57), William Whitehead (1757-85), Thomas Warton, clerk (1785-90), Henry James Pye (1790-

1813), Robert Southey (1813-43), William Wordsworth (1843-50), Alfred Tennyson (1850-92), Alfred Austin (appointed in 1896). See W. Hamilton, *The Poets Laureate of England* (1878); Kenyon West, *The Laureates of England* (1896).

Laurel (*Laurus*), a genus of Lauraceæ, restricted, containing only a single species, the Noble Laurel or Sweet Bay (*L. nobilis*), a native of Asia Minor, but now diffused over all the countries around the Mediterranean Sea. It is often a mere bush of 15 feet or less, but sometimes becomes a tree of 30 or even 60 feet high. It has rather large, lanceolate, leathery, shining leaves, reticulated with veins, and axillary clusters of yellowish-white flowers of no beauty. The fruit is oval, bluish black, and about half an inch long. Both the leaves and the fruit are bitter, astringent, and aromatic, and were formerly much used in medicine as a stomachic and stimulant. The leaves are still used in cookery for flavouring. They contain a volatile oil (*oil of sweet bay*), and a bitter, gummy extractive. See the article BAY, and the illustration there.

By the ancient Greeks the laurel was called *daphne*; it was sacred to Apollo. Berry-bearing twigs of it were wound round the forehead of victorious heroes and poets; and in later times the degree of Doctor was conferred with this ceremony—whence the term *laureation*; and, according to some, the term *Bachelor* (q.v.). And to this day a laurel-crown is the emblem of the honour to which poets, artists, and warriors aspire.

The Noble Laurel is common in shrubberies in Britain, but not nearly so common as the species of Cherry-laurel, which share with it the name Laurel, as do not a few other shrubs botanically very different, but somewhat similar in their evergreen foliage.

LAUREL-CHERRY, or CHERRY-LAUREL, is a name given to those species of *Prunus* (sub-genus *Cerasus*)



Common Cherry-Laurel
(*Prunus laurocerasus*).

(see CHERRY) which have evergreen leaves. They have small flowers in long racemes, and small fruit—the fruit of a nauseous taste—and most parts of the plant, but particularly the buds, leaves, and kernels, remarkably abounding in hydrocyanic (prussic) acid, and therefore very poisonous. The Common Cherry-Laurel (often spoken of simply as the Laurel or Common Laurel, or even more erroneously as the Bay Laurel), *Prunus (Cerasus) laurocerasus*, is a shrub, sometimes of the very largest size, with large ovate-lanceolate, convex, smooth, remotely serrated, shining, light-green leaves, and erect racemes of flowers. It was discovered towards the middle of the 16th century by Belon, at Trebizond, and thirty years later introduced by Chéris through the imperial ambassador at Constantinople, and planted at Vienna, whence he soon widely distributed it. Gerard thus mentions it as a choice garden shrub in

England before the end of the century. It is now naturalised throughout the south of Europe, and is one of the most common ornamental shrubs in Britain, where it suffers only from such severe frosts as are of rare occurrence. It is propagated by seeds, layers, and cuttings. Its leaves resemble bitter almonds in smell and taste, and have in great abundance the same essential oil (see ALMONDS, OIL OF), and hydrocyanic acid. From these leaves, by maceration in water for twenty-four hours, and subsequent distillation, is obtained the *Laurel-water*, or *Cherry-laurel water*, formerly employed in medicine as a substitute for hydrocyanic acid. The leaves are sometimes employed also for flavouring puddings, sauces, &c., and are safer for such purposes than oil of bitter almonds, but ought to be used with caution, fatal accidents being on record. A bottle of cherry-laurel leaves bruised and moistened is often carried by entomologists to kill their captured prey. Neither the essential oil nor the hydrocyanic acid seems normally present during the life of the leaf; both are believed to be produced by the decomposition of amygdalin, or by a ferment, but neither of these has been successfully isolated. Several varieties are in cultivation—notably, e.g., var. *latifolia*, large leaved; *colchica*, dwarf, with narrow, shapely serrate leaves; and *caucasica*, which is said to be the handsomest, hardiest, and most vigorous of all. Another species, also very common as an ornamental shrub in Britain, but not quite so hardy, is the Portugal Laurel (*Prunus or Cerasus lusitânica*), a large shrub—sometimes a tree—with smaller dark-green leaves and lateral racemes. It does not grow so well under the shade of trees as the common cherry-laurel. From the dissimilarity of form, size, and tint of their leaves, these species contrast well in the shrubbery. The variety *myrtifolia* is small and compact. The North American cherry-laurels are *Prunus caroliniana* of the southern states, and *P. ilicifolia* of California, both small and handsome evergreens.

Laurentian System, the name given to the lower division of the Archaean System (q.v.) in Canada. For the Laurentian Range of mountains (also named from the St Lawrence), see CANADA.

Lauriston, ALEXANDRE JACQUES BERNARD LAW, MARQUIS DE, marshal and peer of France, was a grand nephew of John Law, the financier, and was born at Pondicherry, 1st February 1768. He was Napoleon's comrade at the Artillery School, received rapid preferment in the army, and held diplomatic appointments at Copenhagen and London. After Austerlitz (1805) he took possession of Venice. He held high commands at Wagram (1809) and in the retreat from Moscow (1812). He fought at Bautzen (1813) and Katzbach, and was taken prisoner at Leipzig. Already emboldened, he was made a peer by Louis XVIII, as not having joined Napoleon during the Hundred Days, and became marquis in 1817 and marshal in 1821. He died 10th June 1828.

Laurium, a mountain (1171 feet) of Attica, NW. of Cape Colonna, and connected by a railway with Athens. It was famous in ancient times for its silver-mines, but these were already exhausted in Strabo's day. Since 1874, however, the great heaps of slag have been profitably worked, and fresh deposits of argentiferous lead and of zinc ore have also been found, so that the most important mining in the kingdom is carried on here. In 1887 nearly 60,000 tons of ores of every kind were exported, besides 2779 tons of pig lead. The mining town that has sprung up has a pop. of over 5000. See *National Review* for July 1888.

Laurustinus (*Viburnum Tinus*, see VIBURNUM), a beautiful evergreen shrub, a native of

south of Europe and North Africa, and belonging to the natural order Caprifoliaceæ. Its beauty is enhanced by its habit of flowering in winter. The flowers are white, in corymbs, and are succeeded by small black berries with a blue bloom, which inflame the mouth, if eaten, like those of Mezeron (q.v.), and are said to be violently purgative, yet are the favourite food of certain birds. *Laurus* suffers from severe winters in Britain, and will not endure the winters of northern Europe and the colder regions of America.

Laurvik, a seaport of Norway, at the head of a small fjord on the western side of Christiania Fjord, 98 miles by rail SSW. of Christiania. It has several sawmills, and exports timber and other products to the value of £155,000 annually; annual imports, £170,510. Pop. (1886) 11,196.

Lausanne, capital of the Swiss canton of Vaud, is picturesquely situated on the southern slope of the Jura Mountains, close to the northern shore of the Lake of Geneva, on which the village of Ouchy (where Byron wrote *The Prisoner of Chillon*) forms its harbour. Two principal parts of the city are separated by a valley, across which a fine bridge (617 feet long and 82 feet high) was thrown in 1844. Lausanne is famous for its educational institutions; amongst these institutions are the new cantonal university, opened in May 1891, and an industrial, music, and other schools. The cathedral, a beautiful Gothic building, begun in the 10th century and completed in the 13th, is the greatest ornament of the city; this church was the scene of the disputation between Calvin, Farel, and Viret in 1536, which led to the introduction of the Reformation in the city. Here are the cantonal museum of natural history and antiquities, and the Arland Museum (1846) of Art, &c. Since 1875 Lausanne has been the seat of the Federal Tribunal, which decides all questions pending between the several cantons, and between the cantons and the federal government. Lausanne is much frequented by visitors from all parts of the world. Here Gibbon resided for many years, and the house in which he wrote the greater part of the *Decline and Fall* is still shown. John Kemble, the actor, died and was buried here. The town has little industry, but considerable trade. Pop. (1888) 31,049, of whom 86 per cent. are Reformed, and 78 per cent. speak French. Benjamin Constant was a native of Lausanne.

Lausitz. See LUSATIA.

Lauterbrunnen, the name of an Alpine valley in the Swiss canton of Bern, through which flows the Weisse Lüt-schine, one of the principal feeders of the Aar. The valley is surrounded by perpendicular walls of sandstone from 1000 to 1600 feet in height, down which pour about a score of waterfalls. Of these the finest is the *Staubbach* ('dust-stream'), 866 feet in height.

Lautverschiebung. See GRIMM'S LAW.

Lautzen. See BIRON.

Lava, any rock ejected from a volcanic orifice in a state of fusion. Lavas differ much in liquidity at the time of eruption—the basic lavas being more fluid generally than those that contain a high percentage of silica. The surface of a lava stream, which speedily cools and hardens, is generally more or less porous and vesicular, from the escape of the confined gases; but, as rock is always a bad conductor of heat, the interior often remains long in a liquid condition, permitting the continued flow of the stream sometimes to a very great distance from the orifice from which it has been discharged, notwithstanding its indurated covering. The end of the stream is a slowly-moving mass of loose porous blocks, rolling and tumbling over

each other with a loud rattling noise, being pushed forward in fits and starts by the viscid lava, when it bursts the hardened crust and rushes on. The structure of the interior of a solid lava-stream shows a compact and homogeneous rock, assuming a more or less crystalline structure as the cooling has been the work of a longer or shorter period of time. Caverns are sometimes formed in lava-streams by the escape of the molten mass below, leaving the cooled crust standing like the roof of a tunnel.

Laval, capital of the department of Mayenne, and one of the most picturesque towns of France, is situated on the river Mayenne, 46 miles by rail E. of Rennes. Its chief buildings, both dating from the 12th century, are the cruciform cathedral and the old ducal castle of the Trémoilles (a prison now), in whose courtyard young Philip de la Trémoille, Prince de Talmont, was guillotined by the Republicans in 1794. Since the 13th century, when Flemish weavers settled here, the town has been the centre of a district noted for its linen-manufactures—linen, ticking, sacking, &c. In the vicinity the Vendéens defeated the Republicans in 1793. Pop. (1872) 24,255; (1891) 38,405.

La Valetta. See VALETTA.

Lavalette, FATHER. See JESUITS, p. 314.

La Vallière, LOUISE FRANÇOISE DE LAUREME LERLANC DE, a celebrated mistress of Louis XIV. of France, was born at Tours, in 1644, of an ancient and noble family. At an early age she lost her father, and was brought to court by her mother, who had married a second time. She was not a great beauty, and was slightly lame; but the winning charm of her manners, and the sweetness of her face, quickly took captive the affections of the king. She really loved Louis, and bore him four children, of whom two died in infancy; but, although she and they received wealth and titles of honour, she never lost her sensitiveness to the dishonour of their birth. When Madame de Montespan became the royal favourite she retired into a Carmelite nunnery in Paris, where she took the veil in 1674. She died 6th June 1710, after having spent more than thirty years in penances and religious austerities. Her *Reflexions sur la Miséricorde de Dieu par une dame pénitente* (1680) was re-edited in 1854. A collection of her letters was published in 1767.

There are Lives of the Duchesse La Vallière, by Quatremère de Roissy (1823), Capéguie (1859), Hous-saye (1860), and Duches (4th ed. 1890). See also Lair (1881), and Pauthé (1891).

Lavater, JOHANN KASPAR, writer on physiognomy, was born on 15th November 1741, at Zürich, studied there under Bodmer and Breitinger, and in 1769 received Protestant orders. He early gained a high reputation by a volume of poems, entitled *Schweizerlieder* (1767). His next publication was *Aussichten in die Ewigkeit* (4 vols. 1768-78), of which several editions were soon called for. The tone of this and similar works is one of high religious enthusiasm, mingled with asceticism and a considerable heaven of mysticism. From 1769 he officiated in the orphanage church in his native city, and from 1778 in the church of St Peter. He brought his keen powers of observation and his skill in judging character to bear upon physiognomy, which he attempted to elevate into a science, in his most celebrated work, *Physiognomische Fragmente zur Beförderung der Menschenkenntniss und Menschenliebe* (4 vols. 1775-78). This work, which Holcroft first translated into English (3 vols. 1793), is written in an extravagant and inflated style. It gave rise to much discussion, was bitterly attacked, as by Nicolai, although Goethe greeted it with praise, and occasioned not a little display of wit and humour from Lichtenberg and others.

Lavater was the chosen spiritual adviser of many persons in Switzerland and Germany, with whom he maintained an unwearied correspondence. On his tours in Germany he was received with extraordinary marks of popular esteem and honour. Whilst tending the wounded on the street at the capture of Zurich by Massena, 26th September 1799, he received a wound, of the effects of which he ultimately died on 2d January 1801. His *Verwünschte Schriften* appeared in 2 vols. (1771-81) and his *Sämmtliche Kleine prussische Schriften* in 3 vols. (1784-85). See Lives by Gessner (1802), Heisch (English, 1842), and Müncker (1883), and monographs by Steck (1884) and Von der Hellen (1888).

Lavaur, a town in the French department of Tarn, on the Agout, 25 miles ENE. of Toulouse. A bishop's see from 1317 to 1891, it was the strongest fortress of the Albigenes, but in 1211 was taken by Simon de Montfort. Pop. 4651.

Laveleye, EMILE LOUIS VICTOR DE, political economist, was born at Bruges on 5th April 1822, studied at Paris and Ghent, and was appointed to the chair of Political Economy at Liege in 1864. His works include *De la Propriété et de ses Formes Primitives* (1874; Eng. trans. 1878); *Lettres d'Italie* (1880-84); *Le Socialisme Contemporain* (1881; 3d ed. 1886; Eng. trans. 1885); *Éléments d'Économie Politique* (1882); *La Péninsule des Balkans* (1886; curtailed trans. 1887); and works on 'moral economy' in the Netherlands, and on current topics of the day, such as education, luxury, the gold question, and democracy. He contributed to the *Revue des Deux Mondes* and some of the English reviews. He was made a baron just before his death, 2d January 1892. See Life by Count Goblet d'Alviella (1892).

La Vendée. See VENDEE.

Lavender (*Lavandula*), a genus of labiate plants, having the stamens and style within the tube of the corolla, the upper lip of the corolla bilobed, the lower trifid. The Common or Narrow-leaved Lavender (*L. vera* or *L. angustifolia*), grows wild on stony mountains and hills in the south of Europe, and in more northern regions is very generally cultivated in gardens. It has a delightful aromatic fragrance, and an aromatic bitter taste, and contains a great quantity of a volatile oil, *oil of lavender*. The whole plant possesses stimulant properties, and is used in medicine, but particularly the spikes of the flowers, as a tonic, stomatic, nervous stimulant, &c. Lavender flowers are often put into wardrobes to keep away moths, and are much used in perfumery. *Oil of Lavender* is procured by distillation of lavender flowers with water, and is rather lighter than water, pale yellow, very fluid, and very fragrant; it requires 70 lb. of flowers to yield 1 lb. of oil. *Spirit of Lavender* is made by distilling lavender flowers with rectified spirit; *Lavender Water*, one of the most popular of all perfumes, by dissolving oil of lavender with smaller quantities of other volatile oils in rectified spirit. Lavender is extensively cultivated for its flowers at and near Mitcham in Surrey, and at Hitchin (q.v.) in Hertfordshire. Broad-leaved Lavender (*L. latifolia* or *L. spica*) is also a native of the south of Europe, but is more tender than common lavender. It is also less fragrant, and the oil which it yields is called *Oil of Spike*, and sometimes *Foreign Oil of Lavender*. This oil is used by painters on porcelain, and in the preparation of varnishes.

Laver, a name given to a number of kinds of seaweed, which are used as food, especially *Porphyra vulgaris* and *P. laciniata*, of the sub-group Florideae, or red seaweeds (Algae). These plants grow on rocks and stones in the sea, and are not

unfrequent on the British shores. They consist of a very thin, flat, purple frond, which is not gelatinous. The frond of *P. vulgaris* is wavy and undivided, that of *P. laciniata* (sometimes called Sloke) is deeply cleft, and has the segments lobed and cut at the edges. Laver is sometimes stewed and brought to table; also pickled and eaten with pepper, vinegar, and oil, or with lemon-juice. It is regarded as useful in serofulous affections and glandular tumours, a property which it probably owes to the iodine which it contains. Porphyra is the 'red laver' of commerce. The name of Green Laver is given to *Ulva latissima*, of the sub-group Chlorophyceae, or green algae. It is a common seaweed of the British shores, the frond of which is green, membranous, broad, flat, wavy, and sometimes inflated. It is bitterish, but is often used in the same way as the true laver, and possesses similar properties.

La Villemarqué, THÉODORE CLAUDE HENRI HERSART, VICOMTE DE, Celtic antiquary and scholar, was born of an ancient Breton family at Quimperle, 6th July 1815, and became in due time a member of the Institute, and a corresponding member of the Berlin Academy. His first important work was *Barzaz Breiz* (2 vols. 1839; Eng. trans. by Tom Taylor, 1865), a collection of popular Breton songs and melodies, with a French translation and notes. Unfortunately the scientific value of this work was seriously impaired by the embellishments added to the ballads by the editor, and the composite product of artificially made history and affected archaisms can be accepted neither as sound literature nor as safe philology. The author was inspired by glowing patriotism and a too facile imagination, but his conscience failed to teach him the respect that is due to the grave dignity of history. But Brittany is not the Scottish Highlands of Macpherson's day, and Breton scholars are too learned for such impositions. An admirable exposure of the defects of M. de la Villemarqué's work is Luzel's paper, *Les Chants du Barzaz-Breiz* (1872). He died 9th December 1895.

Later works are *Contes populaires des Anciens Bretons* (2 vols. 1842), *Poésies des Anciens Bretons* (1850), *Notices des Principaux Manuscrits des Anciens Bretons* (1856), *Le Grand Mystère de Jésus* (1865), *La Légende Celtique en Irlande, en Cambrie et en Bretagne* (1859), *Méredinn ou l'Enchantement Merlin* (1861), *Les Romains de la Table ronde* (3d ed. 1860), and *Poésies Bretons du Moyen-âge* (1879). He also edited *Le Guide des Dictionnaires Français-Breton* (Saint-Brieuc, 1857).

Lavoisier, ANTOINE LAURENT, the founder of the antiphlogistic or modern chemistry, was born in Paris, on 26th August 1743, and devoted himself to scientific studies, particularly to chemistry. In order to obtain means for more fully prosecuting his investigations he accepted, in 1769, the office of farmer-general. In 1768 he was made an academicien. As director of the government powder-mills, he discovered in 1776 a way of greatly improving the quality of gunpowder; and in 1791 he was appointed a commissioner of the treasury. He rendered great service in the application of chemistry to agriculture. A statement of his principal discoveries, and of the great part he played in the establishment of modern chemistry, will be found under CHEMISTRY; his discovery of oxygen was wholly independent of Priestley (see *Nature*, xxvii., also WATER). Lavoisier's services to science could not save him from the popular rage against farmers of the taxes during the Reign of Terror, and he died by the guillotine, 8th May 1794. His principal work is the *Traité Élémentaire de Chimie* (1789). His *Complete Works* were published in 4 vols. in 1861-68. See his Life by Grimaux (Paris, 1888); *Edinburgh Review*, July 1890; Berthelot, *La Révolution Chimique: Lavoisier* (1890).

Law is a term which must be variously defined, according to its application. The laws of nature, as expounded by men of science, are general propositions as to the order in which physical events have occurred, and will probably recur; the moral law, or the law of God, is a body of truth thrown into the form of rules for the guidance of human conduct. But when we speak of law we usually mean to indicate the law which is set and enforced by civilised states. Law, in this sense, derives its sanction, or binding force, from the penalties by which men are constrained to obey it or punished for breaking it. The earliest source of law is custom: the customary rules of a primitive community formed the basis of the Civil Law at Rome, as they form the basis of the Common Law (q.v.) in England. Customary law is rigid and formal; in a progressive society it is relaxed and improved by the use of legal fictions, by the influence of Equity (q.v.), and by legislation. At Rome, for example, the growing commerce of the city compelled the praetor to go beyond the civil law (which was a law for Romans only), and to devise a new law of nations, based on principles of equity, such as all civilised men could understand. When the Romans began to study Greek they identified this law of nations with the law of nature, as expounded by the Stoics. The civil law, amended and rationalised by successive praetors and emperors, has furnished most of the nations of modern Europe with the greater part of their legal rules and ideas; even England, while refusing to borrow directly from the *Corpus Juris Civilis*, has derived no small part of her law from that source. Scots law has largely drawn its principles and nomenclature from Roman law.

It is usual to distinguish public law (constitutional and criminal) from private law (which applies to personal status, family relations, property, and contract). Canon Law (q.v.) is not received, as an entire system, by any modern state; but its rules are followed in defining the powers and functions of ecclesiastical persons. The Law of Nations, or International Law (q.v.), is also divided into public and private.

See such works as Maine's *Ancient Law*, Colquhoun's *Civil Law*, Austin's *Jurisprudence*, and Pollock and Maitland's *History of English Law* (1895); also the articles CODE, CONGRESS, CRIMINAL LAW, JURI-SPRODENCE, JURY, JUSTINIAN, LAND LAWS, PARLIAMENT, &c.

Law, JOHN, originator of the *Mississippi Scheme*, and famous for his credit operations during the minority of Louis XV., was born at Edinburgh, 21st April 1671. His father was a goldsmith and banker, and proprietor of the estate of Lauriston, near Edinburgh. Law early showed a most remarkable talent for arithmetic, algebra, and kindred sciences. At twenty he removed to London, where he found admission into good society, but was soon compelled to flee, in consequence of a duel in which he killed his adversary. He went to Amsterdam, and spent his time in studying the credit operations of the bank. About the year 1700 he returned to Edinburgh, a zealous advocate of a paper currency; but his proposals to the Scottish parliament on this subject met with an unfavourable reception. He now visited different parts of the Continent, where he won and lost vast sums in gambling and speculation, but sought in vain to win the favour of governments for his financial schemes. At last he settled in Paris, and, in company with his brother William, set up in 1716 a private bank. This was soon so successful and prosperous that the Duke of Orleans, the regent, adopted in 1718 Law's plan of a national bank, and issued prodigious quantities of bank notes, which enjoyed perfect credit, whilst the ordinary national bonds remained, as they had

long been, at a price far below their nominal value. In 1719 Law originated his *Mississippi Scheme* (q.v.), and the following year was made a Councillor of State and Comptroller-general of Finances. When the bubbles burst he became an object of popular hatred, and found it best to quit France. After wandering here and there he finally settled in Venice, where he spent his last years poor and forgotten, yet to the very end occupied with plans for restoring himself to power and prosperity. He died 21st March 1729. See Wood's *Life of Law* (Edin. 1824), and Thiers, *Law et son Systeme des Finances*, of which there is an American translation (New York, 1859). An edition of his works was published at Paris, 1843.

Law, WILLIAM, one of the ablest controversialists of the 18th century, was born a grocer's son at Kingscliff, in Northamptonshire, in 1686, entered Emmanuel College, Cambridge, in 1705, and became a fellow in 1711. At the accession of George I. he found himself unable to subscribe the oath of allegiance, and consequently forfeited his fellowship. About 1727 he became tutor to the father of Edward Gibbon at Putney, and here, or at Cambridge with his pupil, he spent ten years 'the much honoured friend and spiritual director of the whole family.' Gibbon, in his autobiography, speaks of the unworldly thinker with unusual warmth as 'a worthy and pious man who believed all that he professed, and practised all that he enjoined.' The elder Gibbon died in 1737, and three years later Law retired to his native village, and there was soon joined by his disciples, Miss Bester Gibbon, sister of his pupil, and Mrs Hutcheson, a wealthy widow. The two ladies had a united income of about £3000 a year, and most of this they spent in those works of charity to which they devoted themselves in their seclusion, which lasted over twenty years. Law rose at five, and spent many hours of every day in silent meditation and in exercises of devotion. About the year 1733 he had begun to study the writings of Jacob Boehme, and most of his later books are more or less expositions of his mysticism. Law died in his retreat, April 9, 1761. William Law, however unworldly in his theology, was a strong thinker and a consummate dialectician. He won his first triumph against Bishop Hoadly, in the famous Bangorian controversy, with his *Three Letters* (1717). His *Remarks on Manderill's Fable of the Bees* (1723; republished by F. D. Maurice, 1844) is a masterpiece of incisive logic, caustic wit, and terse and vigorous English. Only less admirable is the *Case of Reason* (1732), in answer to Tindal's able book, *Christianity as old as the Creation*. But the most famous of his works remains the *Serious Call to a Devout and Holy Life* (1729), to which Dr Johnson ascribed his first religious convictions, and which profoundly influenced the Wesleys, and earned the praises of Gibbon. Of Law's mystical works may be named *The Way to Divine Knowledge*, and *The Spirit of Love* (1752).

There are two collected editions of his works, each in 9 vols.—that of 1762 and that of Morvion (1893 *et seq.*). See U. Walton's *Notes and Materials for a Complete Biography* (1848), Canon Ovierton's *William Law, Nonjuror and Mystic* (1881), and Dr Whyte's *Character and Characteristics of William Law* (1892). See also Lecky's *History of England in the 18th Century*; and Leslie Stephen's *English Thought in the 18th Century*.

Law Agent. See SOLICITOR, AGENT.

Lawhnrrows, LETTERS OF, in Scots law, a writ commanding a person to give security against offering violence against another. See PEACE.

Law Courts. See COURTS OF LAW.

Lawfeldt, or LAVELD, close to Maestricht in Belgium, was the scene of the defeat of the

combined Austrian, Dutch, and English forces under the Duke of Cumberland by the French, commanded by Marshal Saxe, on 2d July 1747.

Law-merchant, a name often used in law to denote the customs which have grown up among merchants in reference to mercantile documents and business, such as bills of exchange, bills of lading, &c. These customs become incorporated with, and form part of, the common law, and are binding as such.

Lawn, a fine kind of Linen (q.v.), from which bishops' sleeves are made. For grass-lawns, see GARDENING.

Lawn Tennis. See TENNIS.

Lawrence, (1) capital of Douglas county, Kansas, on the Kansas River, 34 miles SSW. of Leavenworth by rail. It is the seat of the state university (1864), and has manufactures of flour, castings, furniture, &c. Pork-packing is extensively carried on. Lawrence was founded in 1854 by Free-soil settlers, shared in the violent struggle against slavery (see KANSAS), and was partly burned by Quantrell's guerillas in 1863. Pop. (1885) 10,625.—(2) One of the capitals of Essex county, Massachusetts, and an important manufacturing city, on both sides of the Merrimack River, 26 miles N. of Boston, with which it is connected by two railways. The river, which here falls 28 feet in half a mile, is crossed by two railway and two other bridges, and by a dam of granite, 900 feet long and 40 high; and canals on either bank conduct the water to the mills. The mills, some of which are amongst the largest in the world, manufacture cotton and woollen goods, cloth, and paper; and engines, boilers, machinery, clothing, hats, &c. are also produced here. Pop. (1870) 28,921; (1880) 39,151; (1885) 38,845.

Lawrence, St. See ST LAWRENCE.

Lawrence, St. the Deacon, a martyr of the early church, the subject of an elaborate hymn by Prudentius. According to the legendary account, he was born at Huesea in Spain, and became a deacon of Rome in the pontificate of Sixtus I. (3d century). In the persecution of Valerian, being summoned before the praetor as a Christian, and being called on to deliver up the treasures of the church, he produced the poor and the sick, who were his special charge; and on his persisting in his refusal to sacrifice, he was condemned to be broiled on a gridiron. The martyrdom is unquestionably historical, its probable date 258. His day is the 10th August. The Escorial (q.v.) is dedicated to him.

Lawrence, GEORGE ALFRED, novelist, was born in 1827, and from Rugby passed to Balliol College, Oxford, where he graduated with a second in classics in 1850. He was called two years later to the bar, was also a militia officer, and died in Edinburgh, 23d September 1876. Of his nine or ten novels the best is *Guy Livingstone* (1857).

Lawrence, LORD. John Laird-Mair Lawrence was one of twelve children of Lieut. col. Alexander Lawrence, an Irish Protestant, who served in the Mysore campaign and at the storming of Seringapatam. Born at Richmond, York-shire, 4th March 1811, he obtained in 1827 a presentation to Haileybury College, where he carried off the chief prizes. His first years in the Indian civil service were spent in Delhi and the neighbourhood. On the annexation of the Punjab Lawrence was appointed commissioner, and afterwards lieutenant-governor. His administration of this once anarchic province made him deservedly popular with Europeans and natives alike. He used every effort to curb the oppression of the people by their chiefs, devised a rational system of land tenure, and devoted his whole time and energy to the work of restoring peace and

prosperity. It was through the influence which he then acquired over the native population that he was able to render such effective service during the Indian Mutiny. Indeed, it is no exaggeration to say that he then proved himself to be the mainstay of the British dominion in India. The once restless Sikhs had become so attached to his firm and beneficent rule that Lawrence was enabled to disarm the mutineers in the Punjab, to raise an army of 59,000 men, and to capture the city of Delhi from the rebels after an eventful siege of three months. So timely was this succour, and so great had been his foresight, that he was thereafter styled 'the saviour of India.' On his return to England he received the thanks of parliament, with the grant of a pension of £1000 a year. He was made a baronet in 1858, and a privy-councillor in 1859. In 1861 Lawrence was nominated one of the knights of the 'Star of India.' In 1863 he succeeded Lord Elgin as Governor-general of India; he was made a member of the Indian council, and the Court of Directors of the East India Company granted him a life pension of £2000 a year. His five years' administration of the Indian empire was marked by the same wisdom, foresight, and prudence as distinguished his career in the Punjab. His financial policy was based upon sound principles; he took a strong personal interest in the many social problems which Indian statesmen have to confront; and his foreign policy was generally approved of. He did not believe in British interference in Asia beyond the frontier of India, and was especially opposed to intriguing in Afghanistan. In 1869 he was raised to the House of Peers as Baron Lawrence. Lord Lawrence was chairman of the London School-board from 1870 till 1873. He devoted the last days of his life in parliament (1878) to an exposure of the policy which led up to the disastrous Afghan war, and which he had vainly striven to counteract in his retirement. He died 27th June 1879. See his *Life* by Bosworth Smith (1883). Sir Richard Temple (1889), and Sir C. Aitchison (1892).

His elder brother, SIR HENRY MONTGOMERY LAWRENCE, was born at Matua, Ceylon, 28th June 1806. In 1823 he joined the Bengal Artillery near Calcutta, where Havelock was stationed at the same time. He took part in the first Burmese war in 1828, in the first Afghan war in 1838, and in the Sikh wars of 1845 and 1848; and in 1848 he was made K.C.B. In 1856, while in charge of the Rajputana province, Lawrence published two articles pointing out the danger of reducing the strength of the British army of occupation in India, and the latent causes of mutiny, which might burst forth at any time. These warnings were more than justified by subsequent events. In March 1857 he was appointed to the charge of affairs in Lucknow, and did all that he could to restore contentment there. But the mutiny broke out in May, and Lawrence saw that it would inevitably spread throughout India. He made extensive preparations at Lucknow, and it was owing to his wonderful foresight that it was made possible for a mere handful of European soldiers to defend the Residency for about four months against an army of the rebels which was in possession of the town. Sir Henry Lawrence himself was injured by the explosion of a shell on 2d July 1857, and died two days afterwards from the effects of the wound. His death was a great blow to the little garrison, but they held out bravely till the end of September, when relief came from Cawnpore. In addition to his reputation as a statesman and soldier, Sir Henry Lawrence is known as a philanthropist, and was the founder of the Lawrence Military Asylums in the Punjab, Rajputana, and Madras. He devoted the most of his income to these and other deserving institutions. A marble statue has been erected to

his memory in St Paul's Cathedral. See his *Life* by Sir Herbert Edwards and Herman Merivale (1873), and that by M-Leod Innes (1898).

Lawrence, Sir THOMAS, portrait-painter and President of the Royal Academy, was born at Bristol, an innkeeper's son, on 4th May 1769, and at the early age of ten years began to draw portraits in crayons at Oxford, afterwards at Bath. At the age of eighteen he entered as a student of the Royal Academy, having a little while previously taken to painting in oil. In 1791 he was elected associate, and in 1798 full member. After Reynolds' death he was appointed limner to the king in 1792, and was knighted in 1815; and on Benjamin West's death in 1820 he succeeded him as President of the Royal Academy. He died in London, 7th January 1830. Lawrence was the favourite portrait painter of his time, had an immense practice, and obtained higher prices perhaps than were paid to any previous portrait-painter. His talent was overrated during his lifetime; his work, in spite of the elegance and taste that often distinguish it, scarcely rises above the conventional level. See *Life and Correspondence of Sir T. Lawrence*, by Williams (1831); and Lord R. Gower's *Romance and Lawrence* ('Great Artists' series, 1882) and *Sir Thomas Lawrence* (1900).

Lawrence, Sir WILLIAM, Bart., F.R.S., a distinguished surgeon (1783-1867), became in 1815 one of the professors of Anatomy to the Royal College of Surgeons, and in 1829 a lecturer on Surgery to St Bartholomew's. He wrote important works on *The Treatment of Hernia* (1807), *An Introduction to Comparative Anatomy and Physiology* (1819), and *A Treatise on the Venereal Diseases of the Eye* (1831).

Lawrenceburg, a city of Indiana, on the Ohio, 22 miles below Cincinnati. Pop. 4284.

Lawson, Cecil (1851-82), landscape-painter, exhibited at the Academy in 1870, but remained obscure, many of his pictures being rejected by the Academy, till 1878, when his 'Minister's Garden' and a 'Pastoral' at the Grosvenor made him famous. The short remainder of his life was a brilliant success. See his *Life* by Gosse (1883).

Lawsonia. See **HELINA**.

Law-terms. See **TERMS**.

Lawyer, in the United Kingdom, is not a technical term of law, but a popular name given to those who are either practitioners of the law or intimately connected with its administration. In Great Britain and Ireland lawyers are subdivided into two main classes (see **ATTORNEYS, SOLICITOR, BARRISTERS, ADVOCATES**). In the United States an attorney acts as counsel, and *vice versa*, there being no similar subdivision of the profession, and the expediency of the subdivision has often been canvassed in the United Kingdom of late years.

Layamon, the son of Leovenath, called in the later text of his poem *Lawman* the son of Leuca, was, as he himself tells us, a priest at Emsley (now Arley), on the banks of the Severn, near Bewdley, and appears to have flourished about the close of the 12th century. Nothing more is known concerning him. He produced an amplified imitation of Wace's *Brut d'Angleterre*, the value of which is not so much literary as linguistic, although it is the earliest existing poem of considerable length in the English tongue. It was confessedly a compilation from Bede, St Alban, and Austin, and more particularly Wace. Wace's *Brut* contains 15,300, and Layamon's 32,250 lines, the additions consisting of dramatic speeches put into the mouths of the figures and of an extension of the Arthurian romance with names of persons and places supplied. The author seems to have been a simple, pious, and patriotic priest—in his own words 'it came to him

in mind and in his chief thought that he would tell the noble deeds of the English.' The versification is very arbitrary and rude, exhibiting sometimes the alliteration of Anglo-Saxon, and sometimes the rhyme of French poetry. The language shows us the Anglo-Saxon changing or changed into Early English, and a study of its peculiarities of grammar and phraseology enables us to trace the process by which the Saxon of Alfred and the Chronicle became transformed into the English of Chaucer and Wyclif. Sir Frederick Madden pointed out that in the earlier of the two MSS. (13th century) of Layamon's *Brut*, there were less than fifty words derived from the Normans; while in the second (written about 1250) twenty of these are dropped and only about forty more added. There are thus but ninety words of French origin in the two texts, together more than 56,800 lines.

The work was edited, with a literal translation, notes, and a grammatical glossary, for the Society of Antiquaries of London by Sir Fred. Madden (3 vols. Lond. 1847). See vol. iii. chap. 6 (1888) of Morley's *English Writers*.

Layard, Sir AUSTEN HENRY, G.C.B., English traveller and diplomatist, was born in Paris, March 5, 1817, and passed his boyhood in Italy. At sixteen he was sent to London to study law. In 1839 he set out on an overland journey to Ceylon. Travelling along the banks of the Tigris in 1840, he was struck with the ruins at Nimrud, pointed out by tradition as the site of Nineveh (q.v.), and felt an irresistible desire to examine the remains. In 1842 Botta, consul at Mosul, conducted some extensive excavations at Khorsabad; and Layard, returning to the region, again directed his attention to Nimrud. It was 1845 before he could obtain the requisite means and facilities for his search, and he then, with the help of some Arabs, began secretly to dig in the mound supposed to contain the ruins. His excavations were resumed in 1846 and 1847, and his energy and perseverance were rewarded by the discovery of the ground remains of four distinct palatial edifices. The most remarkable discoveries were made in the North-west Palace, supposed to have been built by Sardanapalus. The walls had been lined with large slabs of gypsum or alabaster, covered with bas-reliefs and cuneiform inscriptions. Many of these were sent to England by Layard, together with gigantic winged human-headed bulls and lions, and eagle-headed deities. They were placed in the British Museum, of which they have since remained the chief attraction (see **ASSYRIA**). Layard at first conducted his search at his own expense; he was in 1845 liberally assisted by Lord Stratford de Redcliffe, then British ambassador in Constantinople; and eventually, as the value of these specimens of the Assyrian art began to be known, the House of Commons voted a sum of £3000, which was applied by the trustees of the British Museum in continuing the excavations under Layard's superintendence. On his return to England he published a narrative of his explorations under the title of *Nimrod and its Remains* (1849), and another work entitled *Monuments of Nimrod* (1853). He was presented with the freedom of the city of London, received the honour of D.C.L. from the university of Oxford, and was Lord Rector of Aberdeen University in 1855-56. In 1852 he became M.P. for Aylesbury, and in 1860 for Southwark; in 1861-66 he was Under-secretary of State for Foreign Affairs, and thereafter Chief Commissioner of Works. In 1869 he went as British ambassador to Spain; and in 1877-80 he was ambassador to Constantinople. His markedly philo-Turkish sympathies during and after the war with Russia provoked comment at home. In 1878 he received the Order of the Bath. In 1887 he published his *Early Adventures in Persia, Babylonia, and Susiana*. He died 5th July 1894.

Laying, or **LAYERING**, a mode of propagating trees, shrubs, and perennial herbaceous plants which is very frequently employed by gardeners and nurserymen. It consists in bending and fastening a branch, so that a portion of it is imbedded in earth, there to throw out roots, the extremity being made to grow erect in order to form a new plant. The separation from the parent plant is not effected till the layer is sufficiently provided with roots. Any injury which prevents the free return of the sap greatly promotes the formation of roots, and a notch is therefore usually made in the under side of the branch, at the place where the formation of roots is desired; it is also often a little split up from the notch; and sometimes a ring of bark is cut off, or a wire is twisted round it. The time which must elapse before the layer should be separated from the parent plant is very various; a few weeks being sufficient for some, and two years requisite for others. Many plants which cannot readily be propagated by cuttings are more easily and successfully propagated by layers.

Lay-reader, in the Anglican Church, is a layman who receives authority to read the lessons or a part of the service. The incumbent can permit any one to read the lessons, but for authority to read the morning or evening prayer a license from the bishop of the diocese is required. The absolution, of course, cannot be read by a lay-reader, nor any part of the communion service, but he may receive permission, especially in connection with missions, to preach, or to read the sermons of others. Readers (*lectores*, *amgüshai*) have existed as an order in the church from at least the 3d century; in the Greek Church they constitute the first, in the Latin Church the second of the minor orders that lead to the priesthood. (The office was anciently a favourite one with well-born youths; Julian, afterwards the Apostate, was in his younger years a reader in the church of Nicomedia.) Their duty at first was only to read (and perhaps to interpret) the lessons; afterwards they were often employed also as bishops' secretaries, and had some other functions assigned to them. The appointment of readers in the Anglican Church received the sanction of the bishops in 1866; but they were not to be ordained.

Lazarus, MORITZ (born 1824), Hebrew philosophical writer, is since 1873 professor at Berlin.

Lazareff, PORT, a fine natural harbour, 40 to 60 feet deep, and 8 sq. m. in extent, in Broughton Bay on the east side of Cora. It is 390 miles from Vladivostok to the north and 180 from Port Hamilton to the south, and is free from ice in winter.

Lazaretto. See LEPROSY, and QUARANTINE.

Lazarists. See VINCENT DE PAUL.

Lazistan, a coast strip at the south east corner of the Black Sea, partly Turkish, partly Russian, inhabited by the rough Lazs. See GEORGIA.

Lazulite, or **AZURITE**, a mineral long confounded with lapis lazuli (q.v.), but, although somewhat similar in colour, very different in composition; consisting chiefly of phosphoric acid and alumina, with magnesia and protoxide of iron. It occurs imbedded in quartz, or in fissures in clay-slate, in Styria, North Carolina, Brazil, &c.

Lazzaroni (Ital. *lazzaro*, 'leper;') probably from their being outcasts or separate from other citizens), until lately a special class of the inhabitants of Naples. They had no fixed habitations, regular occupation, or secure means of subsistence, but occasionally obtained employment as messengers, porters, boatmen, itinerant vendors of food, &c. They performed an important part in all the revolutions and movements in Naples, and

were wont annually to elect a chief (*Capo Lazzaro*), who was formally recognised by the government.

Le, or **LEH**, the walled capital of Ladakh (q.v.), stands 3 miles from the bank of the Indus, 11,538 feet above the sea. Pop. estimated at about 4000. Le is one of the chief markets of the trade between Tibet and Chinese Turkestan on the one hand and the Punjab on the other.

Lea, a tributary of the Thames, rises near Houghton Regis in Bedfordshire, flows south-east through Hertfordshire, then south between Middlesex and Essex, and joins the Thames near Blackwall, after a course of 46 miles.

Lead is one of the metals which have been known from early times. It is mentioned in Job, xix. 24, and articles made of it by the ancient Romans—some of them inscribed and dated—such as water-pipes, water-tanks, weights, rings, and small ornamental cylinders, are still preserved. As examples found in the grounds of some of the old abbeys and cathedrals show, the Roman method of making pipes from sheet-lead, which differs from the modern way, continued in use till late in the middle ages. Small lead weights of curious forms have been found among Viking remains dating as early as the 10th century. Of lead compounds, litharge and red lead were known to the ancients.

Lead (symbol Pb, atomic weight 207) is a soft metal of a bluish-white colour, tending to gray, and having also a bright metallic lustre when newly cut or melted. Its surface soon tarnishes, however, when exposed to the air, by taking on a thin film of what is supposed to be suboxide. But the oxidation increases so slowly that lead suffers less than most ordinary metals either by exposure to atmospheric agencies or by being placed in damp soils. Lead can be scratched with the nail, and easily cut with a knife, and it makes a streak upon paper. Its specific gravity varies from 11.352 in the ingot to 11.365 when rolled into sheets, and its melting point is 633° F. (334° C.). It is highly malleable and in a less degree ductile, but its tenacity is small—a wire $\frac{1}{16}$ th of an inch being unable to carry a load of 20 lb. Lead is not a good conductor of heat or electricity. When gently heated it can be forced by pressure through perforations, so that pipes and solid rods for rifle-bullets, &c. are in this way manufactured. It is well to bear in mind that pipes, gutters, and cisterns made of lead are injured by hot water. The two former are often twisted and rendered useless by the constant flow of hot liquids through them. Neither sulphuric nor hydrochloric acid in the dilute state has any action upon lead.

The Action of Lead upon Water is of great importance, because the metal is so much employed for pipes and cisterns, and because lead salts dissolved even in minute quantities in drinking-water act as cumulative poisons, and are therefore injurious when taken for some length of time into the system. Lead is rapidly acted upon by pure water to which air has access, such as rain; and it is also dissolved to an appreciable extent by the water of rivers or lakes which is practically free from lime. In these cases the water after passing through lead pipes has an alkaline reaction. The combined action of air (i.e. of its free oxygen) and water oxidises the lead. After a time this hydrated oxide which dissolves is converted by atmospheric carbonic acid into an insoluble basic carbonate of lead. The oxide is again formed and the corrosive action continues or may continue. Bicarbonate or sulphate of lime, which are common salts in potable waters, prevent water acting on lead. So do some other salts; but ammonium nitrate, on the other hand, assists the solution of the lead. Sir Robert Christison found that a very small amount of peat-

extract in solution prevents the action of an otherwise pure water upon lead. But in the case of even a soft and almost pure water, like that supplied to Glasgow from Loch Katrine, the action is so slow that short-service pipes of lead when constantly used are harmless.

Native lead is of rare occurrence, but it has been found very sparingly in a few places. The metal is obtained chiefly from galena or sulphide of lead, which forms veins in different geological formations. There are several oxides of lead, two of which, plumbic oxide and red oxide, are of importance in the arts.

Plumbic Oxide (monoxide of lead, massicot, litharge), PbO . Massicot, from which red lead is manufactured, is obtained in the form of a yellow powder by heating lead to dull redness. Litharge is produced when lead is oxidised, as in the cupellation furnace, at a high temperature in a current of air. The melted litharge flows from the cupel into iron pots, and after cooling breaks up into crystalline scales of a colour varying from a pale to a reddish yellow. This is called flake litharge, and when ground it is termed bull or levigated litharge. Both massicot and litharge enter into the composition of cements (q.v.). Litharge is used in the fabrication of oil-varnishes to increase their power of drying, in the preparation of lead-plaster, and for glazing earthenware. *Red Oxide of Lead* (red lead or minium), Pb_2O_3 , is occasionally found native. Its manufacture is referred to below. There is another kind of red lead, called orange lead, containing more oxygen than minium. *Plumbic Peroxide* (binoxide of lead, puceoxide), PbO_2 , is obtained by treating the red oxide with dilute nitric acid. This oxide, which is of a brown colour, is used mixed with sulphur along with other ingredients for tipping some kinds of matches, the mixture of puceoxide with sulphur being spontaneously inflammable when rubbed.

The most important lead salts are the following: *Plumbic Carbonate* (carbonate of lead, white lead), $PbCO_3$; the cerussite of mineralogists, and now largely mined in the United States as an ore of lead. White lead is manufactured on a large scale by the process described below. *Plumbic Chloride* (chloride of lead), $PbCl_2$. The minerals matlockite and mendipite are both oxychlorides of lead. By a process introduced by H. L. Pattinson, a basic chloride of lead is made for use as a white pigment, which is, however, not so serviceable as ordinary white lead. *Lead Acetate* (sugar of lead), $Pb(C_2H_3O_2)_2 \cdot 3H_2O$, is prepared by dissolving massicot in dilute acetic acid. It can be obtained in transparent crystals or in scales by evaporating the solution. It is soluble in 1½ part of cold water, and in eight parts of alcohol. Like litharge, it is used in the manufacture of oil-varnishes, and it is an important substance in medicine. For the chromate of lead, which is employed as a yellow pigment, see under CHROMIUM.

The following are some of the tests for lead compounds in solution: An addition of hydrochloric acid produces, unless in very dilute solutions, a white precipitate of lead chloride unaltered on adding ammonia. Sulphuretted hydrogen produces a black precipitate, and this precipitate when heated with strong nitric acid is converted into insoluble white sulphate of lead. Chromate of potash produces a yellow precipitate, which has the same appearance as the precipitate this chromate gives with baryta, but the chromate of lead is soluble in caustic potash, while chromate of baryta is insoluble. Lead compounds, when mixed with a little carbonate of soda, are easily reduced to the metallic state if heated on charcoal in the inner blowpipe flame.

Uses and Smelting.—Until recent years only a

small quantity of lead was obtained from any other ore than Galena (q.v.). This is a sulphide of lead (lead, 86·6; sulphur, 13·4), and is found extensively, more or less pure or associated with other ores, in Great Britain, Germany, Spain, and other European countries. About one-third of the British supply is obtained from the Crossfell district, where the counties of Cumberland, Durham, and Northumberland meet. A few other English counties, Wales, the Isle of Man, and Scotland, also yield lead. The total quantity of ore now annually raised in Great Britain is about 50,000 tons, yielding nearly 40,000 tons of lead—less than was formerly usual.

The United States is now a large producer of lead, the Colorado smelting-works alone, which first rose into importance in 1878, yielding as much as 70,000 tons in the year 1887. The works and mines of this state are chiefly at Leadville, where much of the ore obtained is cerussite or native carbonate of lead. The earlier discovered Nevada lead-veins produced 31,000 tons of lead in 1877, but only 3400 tons in 1887. Utah, Idaho, Montana, New Mexico, Missouri, and Kansas also produce lead. The total lead produce of the United States in 1896 was 187,000 short tons (of 2000 lb.).

Some of the rarer lead minerals, not already mentioned, are anglesite or sulphate of lead, lanarkite, which is a basic sulphate, pyromorphite or phosphato-chloride of lead, and bournonite, consisting of the sulphides of lead, copper, and antimony. All galena is more or less argentiferous.

Galena when taken from the mine is broken up into small pieces or reduced to powder, and the impurities, in so far as these can be removed mechanically, separated by machines noticed under METALLURGY. If the dressed galena is nearly pure, as it often is, the smelting operation is simple. A charge of ore amounting to at least 20 cwt. is first partially roasted or calcined for about two hours on the bed of a reverberatory furnace, such as is shown in fig. 1, which results in one portion

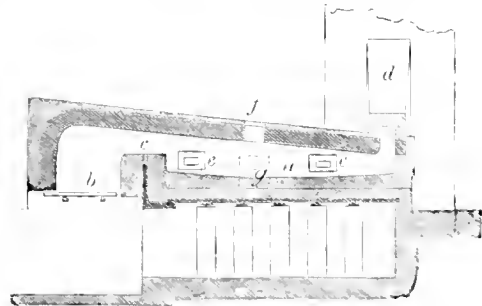
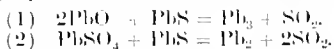

Fig. 1.—Section of a Reverberatory Lead furnace:

a, hearth on which ore is spread; *b*, the fire-place or grate; *c*, the fire-bridge; *d*, chimney; *e*, *f*, working doors; *f*, opening for supplying ore; *g*, tap-holes.

being converted into oxide and another into sulphate of lead, while some of the sulphur goes to form sulphurous acid, which escapes as gas. There remain on the hearth of the furnace oxide, sulphate, and some unaltered sulphide of lead. These, when the heat is raised and the furnace doors closed to practically stop the supply of air, react upon each other, forming sulphurous acid and metallic lead. Towards the end of the process some lime is thrown in to aid in the manipulation of the slag and uncombined ore; and when a further portion of metal is extracted from these the melted lead is run off into a vessel, and the slag removed from the furnace. The changes which take place in the later

or melting stage of the process are shown by the following equations:



In the northern lead districts of Great Britain the calcined ore is removed from the reverberatory furnace and smelted with the aid of a blast of air on a separate ore-hearth called the 'Scotch furnace.'

Owing to lead being to some extent volatile at a red heat, a considerable quantity of the metal would, if not prevented, pass from the smelting-furnaces into the atmosphere as smoke or fume, and cause a loss of, sometimes, 10 per cent. of what the ore should yield. Moreover, lead smoke destroys vegetation for some distance around the furnaces, and herbage on which the fume condenses is apt to poison animals feeding upon it. At Holywell in Flintshire, Alston Moor in Cumberland, and at other lead-works this smoke is conveyed through a system of flues whose combined length amounts in some cases to several miles. Sometimes it is one very long flue. The fume condenses on the sides of these flues, openings being left to collect it. Condensing chambers are also used, in one form of which the lead fume is precipitated by being forced through water. These condensers are constructed to save the expense of long flues, but sometimes both are employed. The lead is of course extracted from the collected fume. In the Harz Mountains, and in some other lead-mining and smelting districts lead is extracted from complex ores—that is to say, from argentiferous galena associated with comparatively small quantities of the sulphides of copper, iron, zinc, and antimony, together with a gangue of quartz (silica), alumina, calc-spar, heavy-spar, and brown-spar. For such ores what is called the *precipitation by iron* or the *iron-reduction process* is, in some cases at least, more suitable than the air-reduction process described above. A certain proportion of iron is added to the charge of ore in a blast-furnace, with charcoal or coke for fuel, because the sulphide of lead is completely reduced when heated with metallic iron, since this metal

As an example of a water-jacketed blast-furnace for lead-smelting we give in fig. 2 a vertical section of the cupola-shaped one called the Pilz furnace now in use at Freiberg, and which has also been adopted in the United States. It has eight tuyères, and varies in size from 4 feet in internal diameter, and 14 feet high from the hearth plates, up to 20 feet in height, with a proportional width across. In the United States, however, the Rchette or rectangular form of blast-furnace seems to be preferred, because its capacity can be increased by lengthening it on plan without also increasing the height, as must be done if a circular furnace is made larger in diameter. The pressure of the blast in these furnaces is from $\frac{1}{2}$ to 1 lb. per square inch. The ore smelted at Leadville, Colorado, is, as already stated, largely cerussite or carbonate of lead, and this is easily reduced in a blast-furnace by coke or charcoal.

Desilverising, &c.—Lead usually contains antimony, tin, zinc, and other metals as impurities. These are separated by fusing the metal in shallow pans, when the foreign metals form oxides, and as such are skimmed off. Lead reduced from galena always contains a little silver, of which 8 or 10 oz. to the ton of lead is a very common proportion, although it often exists in much larger quantity, and as little as 2 oz. to the ton can now

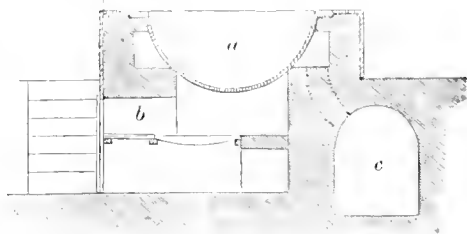

Fig. 3.—Desilverising Pot:
a, pot; b, fireplace; c, main flue.

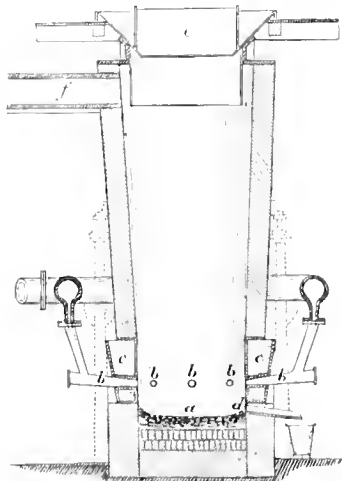

Fig. 2. Vertical Section of the Pilz Blast-furnace for melting lead:
a, hearth; b, tuyères, by which air-blast enters; c, water-jacket; d, tap-hole; e, cover; f, flue.

has a greater affinity for sulphur than lead. The reduction of these complex ores is, however, rather a combination of processes than a single one. Besides lead and silver, copper and sometimes other metals are obtained as accessory products.

be profitably extracted. The desilverising process patented by H. L. Pattinson of Newcastle-on-Tyne in 1853 is still much used. A series of cast-iron pots about 6 feet in diameter (see fig. 3) is used in the process. The argentiferous lead from the smelting furnace is melted in one of these and allowed to cool slowly, and at the same time it is briskly stirred. A portion of the lead is thus made to separate in small crystals, which, as pure lead solidifies at a higher temperature than when it is alloyed with silver, leaves the fluid portion richer in silver. Suppose that the lead to begin with contains 10 oz. of silver to the ton; then if two-thirds of the charge of this pot, which is usually the centre one of several, is transferred as crystals to another pot it will contain only about 5 oz. of silver to the ton. The one-third remaining in the liquid state will contain 20 oz. of silver to the ton. With both portions this process is repeated several times, the one becoming poorer, and the other richer in silver after each crystallisation. When the lead is enriched to the extent of from 250 to 300 oz. of silver to the ton the concentration is usually stopped, although it is sometimes carried a good deal further. The silver is then obtained from this rich lead by melting it on a flat bone ash cupel, placed in a reverberatory furnace, and exposing it to a current of air which reduces the lead to the oxide, or *litharge* of commerce, leaving the silver on the cupel. Fully 320,000 oz. of silver are in this way annually separated from British lead, the latter at the same time being improved in quality.

The Rozan process for desilverising lead is the same in principle as Pattinson's, except that steam is used instead of manual labour, the result being that there is a considerable saving in the cost.

Another method of desilverising lead, known as Parkes' process, was patented in 1850. By this method the silver is separated by adding to the melted lead from 1 to 2 per cent. of zinc, which has a greater affinity for silver than lead. The zinc carrying the silver with it forms, on cooling, crusts on the surface. From these crusts the zinc is afterwards distilled, leaving silver mixed with some lead as a residue. A modification of Parkes' method was patented in France by Conduric in 1866. He uses superheated steam for the separation of the zinc from the crust or scum, and for getting rid of any foreign metals remaining in the desilverised lead. It is said that a very pure commercial lead is obtained by Conduric's process.

Rolled out into sheets, lead is largely used for roofing houses and for water-cisterns; and water-pipes are now made from it without soldering, as already stated. It is also of great service in the construction of large chambers for the manufacture of sulphuric acid. Its value for the manufacture of shot is well known. Alloyed with antimony, &c., it is largely consumed for type-metal, and with tin for solder. Much lead is also required for the manufacture of pewter, Britannia metal, &c. See ALLOY.

White Lead or Carbonate of Lead is a substance very extensively used as a white pigment, as a cement, and for pottery glazes. White lead is still largely made by the old Dutch process. Metallic lead is cast into the form of stars, gratings, or thin perforated slabs in such a way as to facilitate its conversion into the carbonate. These pieces of lead placed in earthenware vessels, like flower-pots, containing a little weak acetic acid, are built up in tiers in the form of a stack, and surrounded with spent tan or horse-dung. The heat given out from the dung volatilises the acid, which along with the air changes the surface of the lead into the basic acetate, and this is, in turn, converted into the carbonate by the carbonic acid given off from the hotbed. Metallic lead requires from four to eight weeks for conversion into white lead, during which a repetition of these reactions goes on. In 1890 a company was formed in London to work R. Macdyvor's process, which consists in acting upon oxide of lead (litharge) by a solution of acetate of ammonia, and then precipitating carbonate of lead from the solution by injecting carbonic acid. By this process white lead is very quickly made. The acetate of ammonia is recovered and used again.

Minium, Red Lead, or Red Oxide of Lead, is much consumed in the manufacture of flint glass, as a cement, and as a pigment. For glass-making it requires to be made of very pure lead, as a slight trace of copper would impart a colour to the glass. Minium is prepared by heating *massicot* or monoxide of lead to a temperature of 600° F. in iron trays, in an oven, carefully avoiding fusion. More oxygen is thus gradually absorbed; and a bright-red compound is formed which is the red lead of commerce. Orange lead, made from white lead instead of from *massicot*, is a very pure kind of red lead.

Yellow Lead.—This name is sometimes given by manufacturers to a mixture of the oxides of lead and antimony, which is to some extent used to give a yellow colour to earthenware and as a pigment. The so-called *Black Lead* (q.v.), of which pencils, &c. are made, contains no lead.

LEAD-POISONING, or PLUMBI-SM. —Minute doses of lead introduced into the system for some time bring on peculiar and distinctive symptoms. In the 18th century, before its cause was ascertained, the

disease was well known in Poitou (hence called '*colica pictorum*'), in Devonshire, and in the West Indies. It was proved by Sir George Baker in 1767 that it was due in each case to the presence of lead in the prevalent alcoholic drink of these regions—wine, cider, rum respectively, owing to its introduction during the process of manufacture. It is occasionally met with in consequence of the action of water, generally very soft water, on the lead pipes through which it passes to the consumers. But it most often attacks persons brought much into contact with lead compounds, such as makers of white lead, workers in the glaze of potteries, painters, and plumbers. The intestinal canal and the nervous system are affected; gout also occurs. See W. D. Prendergast's monograph on lead-poisoning (1898).

(1) Lead or painter's colic is much the most common form of the disease. It consists in more or less severe attacks of pain in the abdomen (see COLIC), not differing much except in their persistency and frequent recurrence from pains otherwise produced, attended by obstinate constipation and frequently by vomiting. They may be so slight for some time that they do not interfere with the sufferer's continuing his work. Lead-colic is rarely fatal; but may be so if the cause of the affection is not recognised.

(2) The commonest affection of the nervous system is paralysis of some of the voluntary muscles; usually those first and most affected are the extensor and supinator muscles of the forearm, and the muscles of the ball of the thumb; and from the characteristic deformity thus arising the condition is termed *wrist-drop*. Other muscles may be first or alone affected; but in almost all cases the muscles of the upper limbs are those where the disease manifests itself. It is not certain whether the nerve-trunks or the centres in the spinal cord are the primary seat of morbid change. Atrophy of the brain-substance, or of the optic nerves, epileptic attacks, and coma occasionally occur as results of lead-poisoning. All the nervous disorders are generally preceded by lead-colic.

(3) The association of gout with lead-poisoning is frequent; and the former is certainly sometimes produced by the latter. But it is probable that gouty subjects are specially sensitive to the action of lead. Cirrhosis of the kidneys (see KIDNEYS, DISEASES OF) occurs in some cases; but whether it is ever a primary effect of lead-poisoning, and not due to induced gout, is not quite certain.

Besides the more obvious effects of the poison above described, there are others of great importance, as they aid in the discovery of the cause of the disease. The most distinctive is the formation of a dark line along the edges of the gums close to the teeth, due to precipitation of lead in the form of sulphide in the tissues. The general health usually suffers, the complexion is sallow and the skin dry and harsh.

Prevention. The most important point to be attended to is that those exposed to the cause of the disease should pay scrupulous attention to cleanliness; should never eat in their workrooms, or without washing their hands; and where dust containing lead is present should wear respirators during their work. Lemonade or some other drink slightly acidulated with sulphuric acid should be used as a beverage, for it forms the insoluble and inert sulphate of lead with any other lead compound which has obtained access to the stomach. Where the water supply is at fault lead pipes must be discarded, or means must be taken to render the water hard before it is admitted to the pipes.

Treatment. When lead is present in the system and causing any of the symptoms above described, its removal can be effected by the administration of

iodide of potassium (see IODINE). Sulphuretted baths, formerly recommended, are of doubtful efficacy. Lead-colic requires the free administration of castor-oil or other purgatives; and lead-paralysis is often benefited by stimulation of the affected muscles by electricity.

Lead, on shipboard. See SOUNDING.

Leadhills, a village of Lanarkshire, the highest in Scotland, being about 1300 feet above sea-level, on Glengonner Water, 45 miles SSW. of Edinburgh. Allan Ramsay was a native. Lead has been mined here for at least six hundred years, the annual output ranging between 700 and 1800 tons of lead. Pop. 998. See Irving's *Lanarkshire* (1864).

Leading Question is a technical expression in law to denote a question so put to a witness as to suggest the answer that is desired or expected. Thus, if a witness is asked: 'Was he dressed in a black coat?' it is supposed the witness will answer, 'Yes;' whereas the proper way of putting the question is: 'How was he dressed?' or, 'What kind of coat?' &c.

Leadville, a mining-town of Colorado, capital of Lake county, stands in a valley 10,200 feet above the sea, 70 miles (151 by rail) SW. of Denver. Its mines produce gold, silver, and lead (see page 544). The town, which was incorporated in 1878, contains numerous smelting-furnaces and stamp-mills. Pop. (1880) 14,820; (1890) 10,384.

Leaf. Leaves are lateral organs developed from the stem or Axis (q.v.) of the plant below its growing point. They never bear flowers, and after reaching their full development they retain their form and size unchanged until death, after which they are removed from the stem either by gradual decay (most monocotyledons) or by breaking off at a distinct articulation (most dicotyledons). They normally consist of two main parts, a stalk or *petiole*, and a blade or *lamina*, the latter being usually flattened and expanded. They may also possess lateral appendages or *stipules* at the base of the petiole. Physiologically considered, they are of the highest importance, as can best be understood after examination of their minute anatomy. The petiole resembles a stem in structure; the blade, however, is distinguished by the great development of cellular tissue, through which the fibro-vascular bundles pursue a course usually similar to that which they possess in the stem, thus exhibiting the parallel and reticulated venation so characteristic of Monocotyledons (q.v.) and Dicotyledons (q.v.) respectively. Taking

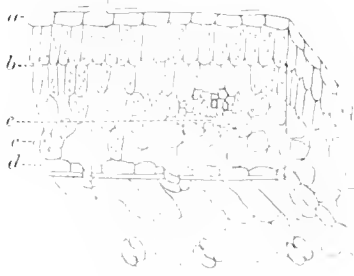

Fig. 1.—Transverse Microscopic Section of a Leaf:

a, upper epidermic layer with cuticle; *b*, palisade parenchyma; *c*, spongy parenchyma; *d*, lower epidermic layer with stomata; *e*, fibro-vascular bundle.

common examples of such leaves, it is easy to make out all the principal tissues (see BARK): (1) thus, by tearing the leaf obliquely, we can remove shreds of dry, colourless, transparent *epi-*

dermis, which exposes the subjacent (2) cellular ground tissue or parenchyma, which is dark green on the upper, and paler because of looser texture on the lower side, while (3) the fibro-vascular bundles can readily be prepared as a skeleton by scraping, or better by maceration. A thin transverse section placed under the microscope shows, proceeding from above downwards, (1) the upper epidermis, a continuous layer of empty cells, with walls often considerably thickened, especially on the upper surface, to form the so-called cuticle; (2) the parenchyma, which contains the fibro-vascular bundles, and which is readily distinguishable into two chief layers. Above is the so-called 'palisade parenchyma,' in which the cells are elongated vertically and placed close together like the posts of a palisade, and below this lies the loose parenchyma of the middle and lower surface of the leaf, in which the cells are polyhedral and loosely arranged, leaving irregular air-passages. Finally we have the lower epidermis, in which numerous openings, the *Stomata* (q.v.), place the spaces in the parenchyma in continuity with the external atmosphere.

The essential function of leaves resides in their chlorophyll-containing parenchyma, in which, in presence of light, carbonic acid (CO_2) is decomposed with evolution of oxygen into the atmosphere and formation of starch (see CHLOROPHYLL, VEGETABLE PHYSIOLOGY). This process has, of course, nothing to do with the function of *Respiration* (q.v.)—oxidation of protoplasm with formation of carbonic acid which is going on constantly during life in all the tissues of plants as well as of animals; it is a compensatory process whereby the green plant is enabled to repair its respiratory losses of matter and energy, and provide for its continued growth by the fixing of new matter from the atmosphere and new energy from the sun. The newly-formed starch is first distinguishable in the form of granules, which are visible in the substance of the chlorophyll grains, is then digested into a soluble body, probably glucose, and carried off by the descending Sap (q.v.), to be either directly assimilated to form new protoplasm, or to be reconverted into starch and stored for future use.

The functions of the blade of the leaf are shared to some extent by the petiole, by the green cellular envelope of the stem and branches (which thus not infrequently come to replace the leaves altogether, good respective instances being furnished by cactuses and acacias), and often by the calyx and ovaries; in short, every part of the plant exposed to light tends to utilise it by producing chlorophyll, excepting only those parts of the flower where, in current phrase, more conspicuous colouring matters are required for the attraction of insects.

The forms of leaves are greatly varied, often obviously in adaptation to the habit of the plant, large and free-growing plants which obtain unobstructed light most frequently bearing simple or slightly lobed leaves, while the smaller vegetation generally produces leaves either long, simple, and narrow (e.g. grasses), or highly compound, with small leaflets (e.g. ferns), so as to seize as many as possible of the broken sunbeams which have not been intercepted by the loftier plants, while casting as little shadow as possible upon each other. Again, the leaves of aquatic plants, if floating, are simple and largely expanded, so as to maintain their position and obtain the maximum of light (e.g. water-lily and pond-weed), but if submerged are usually dissected into filiform segments (water-pinrose), so as to allow the water to flow unobstructed, and thus constantly renew the supplies of carbonic acid. Again, where in one and the same plant the leaves on the lower and upper

portion of the axis are in different circumstances, their form is also varied, and we have the *heterophyllous* condition, which can be seen in many land-plants, but perhaps most conveniently in the water-butternut (*Ranunculus aquatilis*), which possesses both floating leaves which are simple, and submerged leaves which are highly dissected. So, too, plants which grow in dry and sandy situations, and obtain scanty supplies of water, either owing to drought or to too pervious soil, very frequently store their water in their leaves, which thus become succulent, and preserve it from the evaporative action of the sun by the aid of a thickened epidermis containing unusually few stomata.

Again, leaves may acquire entirely new functions, and have their form altered in correspondence with these. Where the plant is a climber the whole or part of the leaf may be modified into a tendril; where it is insectivorous it may be converted into a fly-trap (see INSECTIVOROUS PLANTS); or, as in the very highly specialised *Nepenthes*, we may have the base of the leaf of ordinary form and function, the middle twining as a tendril, and the tip hollowed and enlarged into a complicated pitcher.

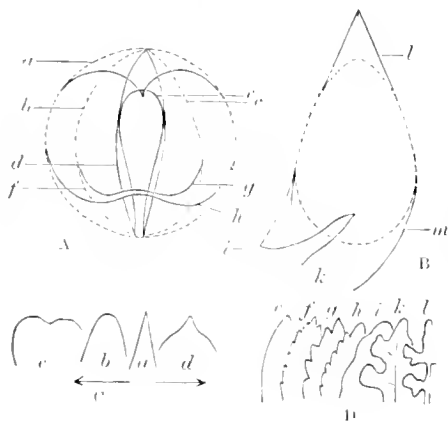

Fig. 2.

A, B, forms of leaves—1, circular; 2, elliptical; 3, oval; 4, linear; 5, spatulate; 6, ovate; 7, hastate; 8, sagittate; 9, pointed ovate; 10, ovate-lanceolate. C, Leaf-tips—*a*, acute; *b*, obtuse; *c*, retuse; *d*, acuminate. D, Leaf-margins—*e*, entire; *f*, serrate; *g*, dentate; *h*, crenate; *i*, undulate; *k*, lobulate; *l*, divided.

Where protection is required, new modifications present themselves; if herbivorous mammals threaten the existence of the plant, the leaves or leaf-tips may become converted bodily into thorns, or covered with epidermic prickles. Bitter or acrid secretions, too, may develop, or stinging hairs be produced; while, if ants are to be guarded against, a hairy or glandular epidermis is the surest protection. Such at least are the interpretations commonly current (see DARWINIAN THEORY).

Such physiological considerations being grasped, comparatively little stress need be laid (save for purposes of specific description) upon the elaborate nomenclature of leaf forms with which botanical text-books are apt to be overburdened.

The parenchyma of the blade may be either in one continuous piece, when the leaf is said to be *simple*, or cut up into separate leaflets, when it is termed *compound*. Simple leaves may be conveniently reduced to three main forms, the *circular*, the *elliptical*, or the *oval*, according to the respective length and position of the longitudinal and the transverse diameter; the *linear* leaf being thus regarded as an elongated variety of the ellipti-

cal, and so on. Innumerable variations in detail arise, however, according to the shape assumed by the apex, the margin, or the base of the leaf. The apex may be *obtuse* or *acute*, *retuse* or *acuminate*;

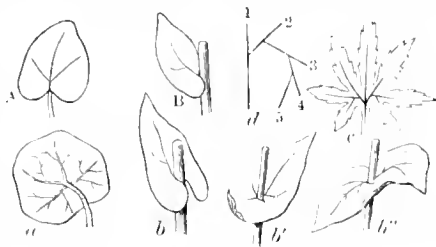

Fig. 3.

a, petiolate leaf derived from A by backward prolongation of the lobes; *b*, amplexicaul leaf; *b'*, perfoliate; *b''*, connate; all derived from B; *c*, petiolate leaf, its branching represented diagrammatically in *d*.

the margin may be *serrate* or *wavy*, or *puckered* into lobes so deep as to furnish transitions to the compound leaf; the base may be *hastate* or *reniform*, and so on. If the leaf base be prolonged beyond the insertion of the petiole and its lobes unite, we obtain the *petiolate* condition familiar in the common Indian Cress (*Tropaeolum*). If the petiole be absent, the leaf becomes *sessile* upon the axis; if its lobes are produced downwards, as in the reniform leaf, they clasp the axis, and the leaf is termed *amplexicaul*; if the lobes coalesce on the other side of the axis, it becomes *perfoliate*; and if they unite with those of a similar leaf arising on the opposite side, the pair are said to be *connate*.

In compound leaves the leaflets may arise one from another on each side of a median lobe, as in the *pedate* leaf of Hellebore, or may radiate in *palmate* fashion from a common point—the end of the petiole, as in horse-chestnut; or, as is most frequent, they may be placed at intervals along the midrib, like the ribs of a feather, when we have the *pinnate* arrangement, of which the ash furnishes a familiar example. The simplest case of pinnate structure is where the lateral lobes or *pinnae* are only two, as in the *ternate* leaf of clover; complex cases also are frequent, termed *bipinnate*, *tripinnate*, or *decompound*, according as secondary, tertiary, or even quaternary series of leaflets are developed.

How little morphological importance can be attached to these countless variations of form is well illustrated by the study of the development of the apparently similar 'pinnate' leaves of palms, dicotyledons, and ferns. In the palm the pinnate character is seen to be due to a mere tearing of a primarily simple leaf, by the midrib continuing to elongate after the parenchyma is developed; in dicotyledons the lobes develop separately, but sometimes from above downwards, and sometimes from below upwards; while in ferns the leaf is produced by a series of regular bifurcations of the growing point alternately to right and left, the first pinna being thus equivalent to all the rest of the leaf, and the apparent midrib a false axis, resulting from numerous separate dichotomies.

The *comparative morphology of leaves* is of the greatest interest. The essential conception, which floated before the eyes of Wolf and of Linnaeus, was renewed by Goethe, and systematised by De Candolle, is that of a fundamental correspondence or *serial homology* among all the outgrowths from the sides of the axis—from the lowest and earliest, the seed leaves or cotyledons, upwards through the leaves proper to the bracts, and even thence through the parts arranged upon the floral axis—the *sepals*, composing the *calyx*, and the

petals, forming the inner floral envelope or *corolla*, being still modifications of the leaf type, which we finally find most highly metamorphosed in the stamens and pistils (see FLOWER).

The transition from leaf to bract can be seen in any flowering plant, that from bracts to calyx may be conveniently studied in the mallow, that from sepals to petals in the cactus, that from petals to stamens in almost any garden rose (which indeed appears to have suggested the whole theory), and that from leaves to carpels in many monstrous flowers, especially the double cherry. Our consideration of the pinnate type of leaf-formation having shown that such apparent resemblances in adult anatomy are not necessarily real, it becomes necessary to test our theory by actual observation of the development of flowers. Embryology here furnishes an absolute confirmation—leaves and sepals, petals, stamens, and carpels, are all seen to develop as precisely similar processes of cellular tissue from

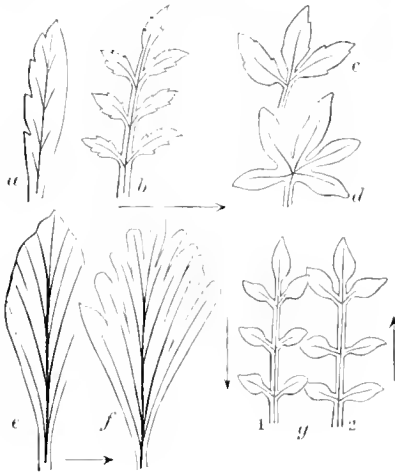

Fig. 4.

a, development of compound from simple leaf; b, imparipinnate leaf; c, trifidate leaf; d, palmate leaf; e, development of pinnate leaves; f, of palm by tearing; g, of dicotyledons by development either (1) basifolial, or (2) basipetal.

the sides of the axis; and when the forms of leaves are fairly borne in mind, the apparent anomalies of flower structure become clear. Thus, the outer calyx (*epicalyx*) of a strawberry is readily seen to be composed of the united stipules of the sepaline leaves, the numerous stamens in five bunches of the St John's wort become resolved into a whorl of compound staminal leaves, and so on. While petals are obviously modified leaves, there is ground both developmental and analogical for regarding them, in some if not all cases, as barren stamens specialised to the attraction of insects; their relation to the leaf type becoming more remote (see STAMEN; and Grant Allen in *Nature*, July 1882).

The arrangement of leaves upon the axis (termed *phyllotaxis*) is always definite, and possesses a high degree of interest, although perhaps rather mathematical than morphological. An ascending spiral line may in all cases be traced round the axis through successive leaf bases, and these are found to occur at fixed distances, including a certain fraction of the circumference, most commonly $\frac{1}{2}$, $\frac{1}{3}$, $\frac{2}{5}$, or $\frac{1}{5}$, although higher fractions of the same 'convergent series'—viz. $\frac{2}{7}$, $\frac{3}{8}$, &c.—or fractions of different series, and even transitions from one system to another, also not unfrequently occur, especially in such complex arrangements as the scales of fir cones. When leaves are opposite there are two

primary generating spirals; when whorled there are three or more. The mode in which leaves are folded in the bud, termed *profoliation* or *vernation* is of interest, since it is definite for each species. See Van Tieghem's, Sachs's, Vines's, and other text-books; also Lubbock's *Flowers, Fruits, and Leaves* ('Nature' series).

Leaf-insect, or WALKING-LEAF (*Phyllium*), a very remarkable genus of orthopteron insects, of the family Phasmoda (q.v.), natives of the East

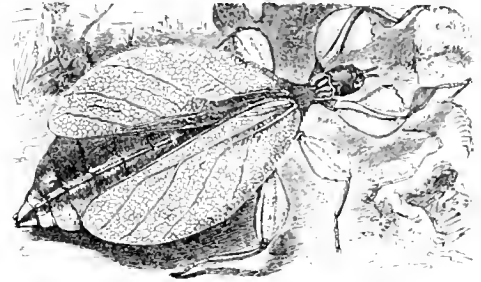

Leaf-insect (*Phyllium sicifolium*).

Indian region. The abdomen is flattened out, and covered in the wingless females by a pair of wing-covers which together look exactly like a leaf. The colour is green, and the suggestion of midrib and netted veins is marvellously mimetic. The legs are also flattened, green, and leaf-like. The male has functional wings, but is also remarkably mimetic. As the insects live among leaves, and are sluggish, their detailed resemblance to the surroundings cannot but be usefully protective. The name of the commonest species (*P. sicifolium*) refers to the fact that when the insects die the green colour changes into that of a withered leaf. See MIMICRY.

League (Lat. *leua*, 'a Gallic mile,' a word of Celtic origin), a measure of length of great antiquity. The Romans estimated it as equivalent to 1500 Roman paces, or 1376 modern English miles. The league was introduced into England by the Normans, probably before the battle of Hastings, and had been by then lengthened to two English miles of that time, or 2½ modern English miles. At the present day the league is a nautical measure, and signifies the 20th part of a degree—i.e. 3 geographical miles, or 3.456 statute miles. The French and other nations use the same nautical league, but the former nation had (until the introduction of the metrical system) two land-measures of the same name, the legal posting-league = 2.42 English miles, and the league of 25 to the degree = 2.76 statute English miles. For the German league or *Mile*, see MILE.

League, a term employed to designate a political alliance or coalition. The most famous leagues were the Ætolian and Achaian Leagues, the Lombard League, the Hanseatic League (q.v.), the leagues of Cumbray ('Holy League'), Schmalkald, Nuremberg ('Catholic League'), and Würzburg in the Thirty Years' War (q.v.); also the Solemn League and Covenant, the Anti-corn-law League, the Land League. But the name has a peculiar importance in the history of France, as applied to the opposition organised by the Duke of Guise (q.v.) to the granting of the free exercise of their religion and political rights to the Huguenots. This league, known as the Holy League (*Sainte Ligue*), was formed at Peronne, in 1576, to maintain the predominance of the Roman Catholic religion; but the object of the Guises was rather to exclude the Protestant princes of the

blood from the succession to the throne. For an account of the civil war that ensued, see HENRY III., HENRY IV., and GRISE; and for its full history, see Mignet's *Histoire de la Ligue* (5 vols. 1829).

Leake, WILLIAM MARTIN, topographer of Greece, was born in London on 14th January 1777, and, having in 1794 obtained a commission in the artillery, was sent out five years later to instruct the Turks. He was employed on various other missions in the Levantine countries, till in 1823 he retired a lieutenant colonel from the army; in 1838 he married the widow of Marsden, the orientalist; and he died at Brighton on 6th January 1860. With critical acuteness and soundness of judgment he combined great learning and an admirable power of clear statement. His principal works are *Researches in Greece* (1814); *The Topography of Athens* (1821); *Journal of a Tour in Asia Minor* (1824); *Travels in the Morea* (1830); *Travels in Northern Greece* (1835); *Greece at the End of Twenty-three Years' Protection* (1851); and *Nannismaticu Hellenica* (1854). See *Memoir* by the Rev. J. H. Marsden (1864).

Leamington, a fashionable watering-place of Warwickshire, is beautifully situated on the Leam, a tributary of the Avon, 2 miles N.E. of Warwick. It is wholly of modern growth, having become important only since the rediscovery of its mineral waters in 1784. They are saline, sulphureous, and chalybeate; and the watering-season lasts from October till May. The town, too, stands in the centre of a good hunting country. Among its buildings are the Pump-room (1868), the Warneford Hospital (1832), assembly-rooms (1813), music-hall (1821), the tennis court (1847), the college (1814), the new municipal offices, and the fine old parish church. The manufacture of cooking-ranges is an important industry. Visited by the Duchess of Kent and the Princess Victoria in 1830, Leamington eight years later received the name of 'Royal Leamington Spa.' It was incorporated in 1875, and since 1885 has united with Warwick to return one member to parliament. Pop. (1811) 543; (1851) 15,692; (1891) 26,930. See F. W. Smith's *Leamington Waters* (1884).

Leander. See HERO.

Leap-year. See CALENDAR.

Lear, EDWARD, author of the inimitable *Book of Nonsense*, was born at Holloway, London, 12th May 1812. From his boyhood he had a passion for painting, and from the age of fifteen he had to make his own living. Later he was sent by the Earl of Derby to Italy and Greece, where he painted many landscapes in Albania, Athos, the Morea, and the islands of the Egean. He exhibited at the Royal Academy from 1850 until 1873. His later years were spent in Italy, and at San Remo he died, January 30, 1888. Lear made himself better known by his illustrated books of travels than by his paintings. Of these the most important were his *Sketches of Rome and its Environs* (1842); *Illustrated Excursions in Italy* (1846); *Journal in Greece and Albania* (1851), which called forth the praises of Tennyson in a well-known poem—'I read and felt that I was there'; *Journal of a Landscape Painter in Calabria* (1852); *In Corsica* (1869). The *Book of Nonsense* (1846; 25th ed. 1888) went at once to the heart of all English children. The extraordinary facility and felicity of the rhymes, and the high level of humour, wit, and good sense, maintained throughout, have kept for it its place in popular favour. *More Nonsense Rhymes* followed in 1870; *Nonsense Songs, Stories, and Botany* in 1879; *Laughable Lyrics* in 1876.

Lease, the contract establishing the relation between landlord and tenant. The granting of

leases, commonly for a term of nineteen years, has become common in Scotland since 1312, and to this system is largely to be ascribed the rapid improvement in agriculture in Scotland during the past century. Every lease has its own peculiarities as drainage, to houses, cropping, &c. See BUILDING LEASE, LANDLORD and TENANT, LAND LAWS; and, as to the compensation for unexhausted improvements, AGRICULTURAL HOLDINGS ACT.

LEASEHOLD is a dependent tenure derived either from a freehold or a copyhold, and held by lease. Schemes for the enfranchisement of leaseholds (allowing persons having long leases of small portions of land a right to purchase the fee simple) concern mainly Building Leases (q.v.). See also GROUND-RENT.

Leasing-making, in Scotch law, means seditionous words, which constituted an offence punishable with death by statutes of 1584 and 1585. The punishment was afterwards mitigated to fine and imprisonment, or both, at the discretion of the court.

Leather consists of the skins of animals chemically modified by tanning and otherwise, so as to arrest that proneness to decomposition which characterises unprepared skins, and to give to the substance greatly increased strength, toughness, and pliancy, with insolubility and inalterability in water. Some method of preparing skins so as to make them wearable must have been known from the very earliest times, and there yet exist remains of tanned leather made in Egypt not less than 900 years B.C. In modern times the methods and principles of leather-making have come to be well understood; but the processes employed in the manufacture have not been seriously modified; the attempts made to hasten the essentially slow processes having met with but limited success. There are three methods by which leather is prepared—first, and by far the most important, with tan barks and other vegetable substances containing tannin; second, by tawing with alum, bichromate of potash, and other mineral salts; and third, by shamoying or impregnating the raw skin with oil.

The skins of all animals used for leather-making consist chiefly of a fibrous gelatigenous substance called collagen, which on being boiled forms the ordinary gelatin of commerce, with an interfibrous compound called corium, insoluble in water, but which in common with collagen unites with tannin to form the insoluble and unalterable compound tanno-gelatin, the chemical basis of tanned leather. The compounds are similarly acted on by bichromate of potash and other mineral salts in tawing, whereby insoluble combinations are formed.

The skins of all animals may be made into leather; but in practice the raw materials of the manufacturer consist of the skins of certain animals which are reared and slaughtered primarily for other purposes, and of which the supply is sufficiently large to form the basis of a great industry. Large skins, it may be remarked, such as those of oxen and horses, are in trade termed hides; those of calves, sheep, goats, and other smaller creatures are called skins. Of all leather-making hides the most important are those of oxen, which are primarily distinguished as ox, cow, and bull hides, and calf skins. To the tanner they come in several forms and from many quarters. The first source of supply is the local slaughter-house, from which the newly-flayed skins called market hides are obtained. From abroad ox-hides come either as wet or dry salted hides, or as simply dried hides, the great sources of supply being Australia, the Cape of Good Hope, the River Plate and South America generally, and China and Japan. From the East Indies there come vast quantities of small hides termed kips, both salted and tanned. Buffalo hides are

imported in large quantities from Singapore, Batavia, Bombay, Kurrahee, and Calcutta. Horse-hides are brought in considerable quantities from South America, and the knacker's yards at home supply fresh hides, which, however, are generally in bad condition. Sheep-skins, from the vast quantities yearly available in nearly all parts of the world, are a most important source of leather. Besides native supplies the British market chiefly obtains them from Australia and New Zealand, the Cape, and Buenos Ayres. Goat skins and kid skins come from the Cape, the East Indies, Asia Minor, and Switzerland; but many of the East Indian and Asiatic skins are when imported already tanned, and require only dressing. A now important source of leather is from seal-skins, the supply of which is derived from the Greenland and Newfoundland fisheries. Other skins which have only a local or a limited market are the walrus, rhinoceros, and elephant, from which leather of great thickness, suitable for polishing-wheels and other mechanical purposes is obtained; and hog or pig skin is an important source of leather for saddle-making and other purposes. The skins of various species of deer and antelope, porpoise and kangaroo, are also sources of leather; and from the Cape there are occasionally sent to the London market skins of the gnu and zebra. As sources of leather for fancy articles there may be mentioned the alligator (a leather now extensively imitated), and certain snakes' and sharks' skins.

Tanning.—The operations of tanning and the duration of the process vary very widely according to the nature of the tanning materials employed, the nature and thickness of the hides and skins under treatment, and the class of leather being produced. The sources of Tannin (q.v.; and see BARK) are exceedingly numerous, but oak-bark is the most important, and that which produces the most valuable and substantial of all leathers. Oak tannage is, however, a very tedious process, and the common practice is now to hasten the completion of the operation by mixed tannage, in which more rapidly acting agents play a part. In America hemlock-bark from *Abies canadensis* is the most important tanning material; and the mimosa or wattle barks of Australia are very largely used in the colonies as well as in Britain. Standard extracts containing a fixed percentage of tannin have also come into favour for rapid tannage. But, with all the devices which have been suggested, tanning is essentially a slow operation, and it cannot be forced through without injury to the resulting leather, any more than can the operations of roasting beef or toasting bread be hastened unduly. The many processes which have been suggested, involving chiefly the use of strong tan liquors, or ooze as it is technically called, and the transfusion of these liquors through the hides, have resulted generally in the production of hard and intractable leather, or of a superficial tanning only. Such imperfectly made leather gets an appearance of uniformity and finish by being impregnated with grape-sugar, or with sulphate of magnesia, chloride of barium and other salts, which add weight, but which otherwise are the most rank and deleterious adulterants.

In the treatment of ox hides for the production of, say, sole-leather, the first object of the tanner is to clean and soften the hide. This is done by washing with water, and if necessary working the hide under stocks till the whole is uniformly soft and pliant. The unhairing and removal of the scarf skin is the next operation, for which in English tanneries the hides are steeped in pits containing lime-water, while in America the plan adopted consists of sweating the hides, or artificially heating them till incipient

putrefactive fermentation is set up. The hides are afterwards stretched over a tanner's beam, and the hair and scarf skin are removed by shaving with a fleshing-knife. At the same time the flesh side is gone over, and any fragments of fibre or fat adhering to it are pared away. All traces of lime in the hides must be got rid of, and that sometimes is effected in the first tan-pit, containing acid liquors weak in tannin, and sometimes by 'bating' in 'pure'—which is a warm decoction of pigeons' or other fowls' dung. The *modus operandi* of actual tanning varies endlessly, but in general it may be said to consist in suspending or depositing in layers the hides in a successive series of pits containing tan liquor or ooze which is weak at first, but which as the tanning proceeds is made increasingly rich in tannin. In the early stages of the tanning the hides are frequently handled or turned over in the tan-pits, as often as two or three times daily at first; but as the tanning progresses this handling becomes less and less frequent, till in the final pits, in which strong liquor is used, and where, moreover, the hides are interstratified with raw bark, they may rest for six weeks without being disturbed. When finally taken from the tan-pit the hides are carefully drained in a heap covered over from the light, after which they are suspended in the loft for drying, in which condition they form rough leather, hard, uneven, and refractory. To finish the hides they are damped and softened in water, scoured to remove the bloom from their surface, then liberally oiled and the whole surface worked over by pressure with a three-sided steel implement called a striking-pin. This operation removes all creases and smooths out and solidifies the leather—an operation carried further and finished after renewed oiling, by rolling the hide on a smooth floor under a heavy hand-roller. For both these operations very efficient machinery is now generally substituted for the old method of hand labour. The different portions of an ox-hide, and of all hides in some degree, possess distinct qualities which render them available for special applications; hence in the trade they receive distinctive names, and frequently are separately dealt in. An entire hide is termed a *crop* (see fig.); one-half the crop cut longitudinally forms a *side*; the pieces around the margins are designated as on the diagram, and collectively form the *offal*; the neck and shoulders are sometimes de-

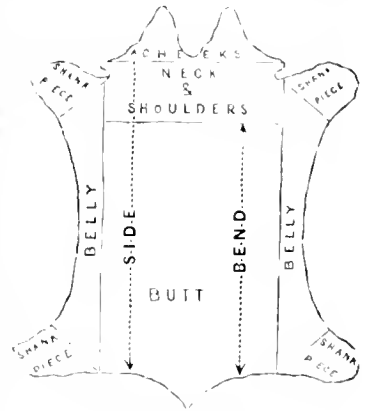

Ox-hide or Crop.

tached from the *butt*, which forms the hide minus the *offal*, and half a butt cut lengthways makes a *bend*.

Dressed Leather.—Under this head there is embraced a great range of leathers which after tanning undergo a varied series of finishing operations at the hands of the currier and leather-dresser, to fit them for the diverse uses to which dressed leather is applied. The currier has to do with the paring down of the flesh side of the leather, to smooth its surface, and to equalise its thickness;

and he also, when desirable, splits hides by means of a machine into two or more useful layers or splits. His further and principal operations have for their objects the rendering of the leather soft, flexible, and waterproof, and giving it the finished surface, grained or smooth, waxed or blackened, glazed or enamelled, dyed, &c. For stuffing the leather, which is the most essential operation of the currier, it is first softened in water, then the surface is gone over with a scraping tool or slicker, and while still wet it is liberally covered with a dubbing composed of mixed tallow and cod-oil. As the moisture evaporates from the leather the grease penetrates and thoroughly permeates the whole texture. For the numerous operations of currying and finishing leather elaborate machinery is now employed, which has almost entirely superseded hand work.

Morocco leather is a term which now applies rather to the finish of a certain class of goods than to the source of the skin of which it is formed. It is a richly grained and dyed leather, originally and properly made from goat-skins tanned in sumach; but now sumach-tanned split calf-skins and sheep-skins are the source of much so-called morocco. Sheep-skins roughly tanned and undressed are termed basils; dressed and dyed as for morocco, but finished smooth, they form roans; and split sheep-skins (the flesh sides of which go to be shamoied to form wash-leather) tanned and dressed are known as skivers. Russia leather is now any smooth finished thin leather, impregnated with the empyrenumatic oil of birch-bark, which gives the substance its peculiar odour and insect-resisting qualities. Originally it was made in Russia of dressed calf-skins.

Tawing consists in dressing skins with certain mineral salts, and is useful principally for glove leathers and the so-called kid-leather employed for the uppers of ladies' boots. It is also by tawing that curriers' skins are prepared, and hides and skins in the hair generally preserved. The process of tawing a lamb-skin may be taken as a typical example of the process, which, however, is much varied, as experience suggests. The skins are generally limed on the flesh side with cream of lime to detach the wool, which is removed as in ordinary hide-tanning. After thorough cleansing, the pelts are steeped for two or three weeks in a pit filled with water and lime, being taken out from time to time, and drained on sloping benches. When removed finally from the lime-pit, the skins are worked with the knife, to render them still more supple, and they are then put into the branning mixture. This consists of bran and water, in the proportion of two pounds of bran to a gallon of water. From this mixture, in about two days, they are transferred to another bath, consisting of water, alum, and salt. After the proper amount of working in this mixture, they undergo what is called the pasting, if intended to form white leather. The paste is a mixture of wheaten-bran and sometimes flour and the yolks of eggs. They are usually worked in a rotating cylinder with this paste and water, and are found in time to have absorbed the paste, leaving little more than the water. If the skins are not intended to be white, other materials are often used, and much pigeons' and dogs' dung is employed. Lastly, the skins are dried and examined, and, if necessary, the pasting is repeated; if not, they are dipped into pure water and worked or staked by pulling them backwards and forwards on what is called a stretching or softening iron, and smoothed with a hot smoothing-iron. Numerous other tawing processes are in use and have been suggested, one of the most promising of which was the chrome tanning of Dr. Heinzerling, introduced about 1876. In

this the active agent is bichromate of potash; after treatment with which the leather is stuffed with paraffin; but the expectations of the promoters of this method of treating leather have not been fulfilled, the demand for chrome-tanned leather appearing to have quite fallen away.

Shamoying consists simply in impregnating and saturating skins with oil. The name is derived from the fact that the process was originally applied for the preparation of the skins of the Alpine chamois, and as it was also used for other deer-skins the name buck-leather or buck-skin was also given to the preparation. Shamoyleather now consists principally of the flesh splits of sheep-skins. The oil is worked by means of stocks slowly into the interstices of the skin and there becomes oxidised, forming a kind of combination with the gelatinous constituents, and yielding a peculiarly soft and spongy texture. A good deal of the buff-leather of commerce is prepared by a process which partakes of the features of both tawing and shamoying.

Owing to the fact that tanners derive a large proportion of their hides and skins from local sources, and dispose of most of their leather in the home-markets, it is not possible to gauge the extent of the trade by published returns. That the international movements of the trade are on a great scale is, however, made plain by the following figures. Into the United Kingdom in 1889 the imports were: dry hides, 575,158 cwt.; salted hides, 647,250 cwt.; leather, 104,916,924 lb., of a value of £6,667,265; boots and shoes, 100,487 dozen pairs. The exports were: dry hides, 365,701 cwt.; salted hides, 52,768 cwt.; foreign leather unwrought, 19,214,996 lb.; British leather, 143,140 cwt.; and wrought leather, value £413,600; boots and shoes, 11,127 dozen pairs; saddlery and harness, value £574,401. The imports into the United States in 1887 were: hides and skins (other than furs) \$24,219,101; leather and leather manufactures, \$10,933,570. Exports: hides and skins, \$765,655; leather, \$10,436,138. See separate articles on PARCHMENT, VELLUM, FURS; works by Collins (1876), Hunter (1885), and Watts (1885); and C. T. Davis's *Manufacture of Leather* (Phila. and Lond. 1885).

Leather-cloth, sometimes called American leather-cloth, or more briefly American cloth, is a textile fabric coated on one face with certain mixtures of a flexible nature when dry so as to resemble leather. Unbleached calico is the most common ground or backing employed, and this is coated with boiled oil, dark pigments, driers, and sometimes other ingredients, made up to such a consistency that the mixture can be uniformly spread on the cloth by rollers. Another method of making leather-cloth is by coating calico with 'linoleum cement' (see FLOORCLOTH). A third and extensively used coating consists of gelatine rendered insoluble by some chemical agent, to which glycerine is sometimes added. But the different mixtures which are or have been employed in making leather-cloth are numerous, and many of them have been patented. A good quality of leather-cloth when employed for covering chairs and sofas has considerable durability. As a cover to writing-tables it is even more durable than morocco leather, and it is not one-fifth of its price. A thicker kind of leather-cloth than that manufactured for upholstery purposes is made of coated linen and used for covering coaches, and there are other applications of this substance. It is more durable when glazed with a varnish than when finished in imitation of morocco leather.

Leatherwood (*Dicella pulsteis*), a deciduous shrub of 3-6 feet high, with the habit of a miniature

tree, a native of North America. It belongs to the natural order Thymeleaceae. The bark and wood are exceedingly tough, and in Canada the bark is used for ropes, baskets, &c. The leaves are lanceolate-oblong; the flowers are yellow, and appear before the leaves.

Leathes, STANLEY, was born at Ellesborough, Bucks, where his father was rector, March 21, 1830. He was educated at Jesus College, Cambridge; graduated B.A. in 1852; took orders four years later; and, after serving several curacies, became in 1863 professor of Hebrew in King's College, London, and in 1869 minister of St Philip's, Regent Street. He was Boyle lecturer (1868-70), Hulsean lecturer at Cambridge in 1873, Rampton lecturer at Oxford in 1874, and Warburtonian lecturer at Lincoln's Inn (1876-80). Further preferments were a prebend in St Paul's (1876) and the rectory of Cliffe at Hoo, near Gravesend (1880). Leathes was made D.D. by Edinburgh in 1878, and sat on the Old Testament Revision Committee. His books include *The Witness of the Old Testament to Christ* (Boyle Lectures), *The Gospel its own Witness* (Hulsean), *Religion of the Christ* (Rampton), *Studies in Genesis* (1880), *The Foundations of Morality* (1882), *Christ and the Bible* (1885), and several volumes of sermons. He died in May 1900.

Leaven. See YEAST, BREAD.

Leavenworth, fourth largest city of Kansas, and capital of Leavenworth county, on the Missouri River, 25 miles NW. of Kansas City by rail. First settled in 1854, it is now a handsome town, of broad avenues, and contains a Soldiers' Home, the state normal school, and large factories and mills. Eight lines of railway centre here, and the river is crossed by a fine iron bridge. Adjoining the city is Fort Leavenworth (1827), an important depot for troops and supplies, with large barracks, &c. Pop. (1880) 16,550; (1890) 19,768.

Leaves. See LEAF.

Lebanon, a mountain-range in Syria, extending from the latitude of Homs in the north (31° 43' N.) to that of Mount Hermon (33° 24' N.) in the south. The word Lebanon is derived from a Semitic root meaning 'white;' and this name is given to the mountains, not because their peaks are covered with snow (as they are even in summer), but because of the whitish colour of their rocks. The mountains belong geologically to the Cretaceous system, and consist principally of limestones and chalks. They are divided into two parallel ranges, the Lebanon on the west and the Anti-Lebanon (or more correctly Anti Libanus) on the east. Between them lies the deep valley of the Beka'a (the ancient Cole Syria), which is from 4 to 6 miles wide, and is watered by the rivers Litany and El-Asi (the ancient Orontes). The former flows south-westwards, then, turning abruptly to the west, reaches the sea a little north of Tyre; whilst the latter flows in the opposite direction, and, after crossing the plains of Hamath, likewise turns to the west to the Mediterranean. The highest summits occur in the north in both ranges, but are higher in Lebanon than in Anti-Lebanon; in the former they vary from 10,018 (El-Kazib) to 7000 feet and less, and in the latter are about 8000 or 9000 feet. In both ranges the eastern versant is the steeper and sterner. The western slopes of Lebanon are broken by numerous deep transverse valleys, running between the spurs that the main chain sends down to the very edge of the sea, where they often terminate in bold headlands. The western slopes of Anti-Lebanon are not so much cut up by valleys as those of Lebanon, but are more barren and more broken by crags and bare rocks. The valleys and the lower slopes of

the hills are generally verdant with vegetation. The vine is extensively grown, and wine is made, but is all consumed at home. Mulberry-trees figure prominently; for the manufacture of silk is one of the most important industries of the mountaineers—it was introduced from China in Justinian's time. Olive-groves and orchards (nuts and figs) abound everywhere. The higher slopes are in many districts covered with forests of oak, cypress, pine, plane, &c. Contrary to the current belief, remains of the great cedar forest of Solomon's time exist in more places than the single grove of 377 trees at the head of Kedisha Valley (see CEDAR). Thickets of low scrubby bushes, generally thorny, and often aromatic, are found at nearly all altitudes. Tobacco, wheat, barley, and millet are the chief crops cultivated. Owing to the elevated situation, the climate is healthy and bracing. Streams of clear water are numerous. The inhabitants (estimated at 221,000 in all) are a hardy, ruddy race of people, of Syrian (Aramean) descent, who keep large herds of sheep and goats. The predominating element is the Maronites (q.v.), more than two-thirds the total; next come the Druses (q.v.). Besides these there are Mohammedans, members of the Greek Church, Metawilé (a sect of Shiite Moslems), and a few converts of the American Protestant and the Roman Catholic missionaries of Beyrout. After the bloody quarrels of the Druses and Maronites in 1860, the district of Lebanon was separated (1861) from the Turkish pashalik of Syria, and put under a Christian governor, the European powers constituting themselves the 'guardians' of the new province. See Conder's *Palestine* (1889) and Baedeker's *Palestine* by Dr A. Socin.

Lebedin, a town of Russia, 87 miles NW. of Kharkoff. Pop. 14,788.

Lebrija (anc. *Nebriſsa-Fenicia*), a town of Spain, 44 miles by rail S. by W. from Seville. Pop. 12,864.

Le Brun, CHARLES, French historical painter, born in Paris, 24th February 1619. He was patronised in his youth by Nicolas Poussin, who took him to Rome, where he was kindly treated by the Barberini, and studied for four years. He then returned to Paris, and was employed by Fouquet on his château of Vaux, and afterwards by Cardinal Mazarin, Anne of Austria, and Louis XIV. He was the first director of the Gobelins Tapestry Works on its foundation by Colbert in 1662. For nearly forty years (1647-83) Le Brun exercised an immense and despotic influence over French art and artists, and is usually considered the founder of the French school of painting, Poussin being rather an Italian than a French artist. From 1668 to 1683 Le Brun was employed by Louis XIV., and given an absolutely free hand in the direction and management of the decoration of the palace of Versailles; but Mignard being favoured by Louvois on his accession to power, and the younger artist consulted by the king as to the completion of the work, Le Brun, who could brook no rival, retired, sickened, and died, 12th February 1690. See works by Genevay (1885) and Jouin (1889).

Le Brun, MARIE, born in Paris, 16th April 1755, was a daughter of one Vigée, a painter of little note, and in 1776 married J. B. P. Le Brun, a picture-dealer and grand-nephew of Charles Le Brun. Her great beauty, as well as the charm of her painting, speedily made her the fashion in Paris and at Versailles. 'Le Brun de la beauté le peintre et le modèle' was the friend of La Harpe and D'Alembert, copied Greuze, and painted all the fine ladies and gentlemen of the day. Her first portrait of Marie Antoinette (in 1779) led to a

lasting friendship with the queen of France. She subsequently painted numerous portraits of various members of the royal family, and in 1783 was admitted, on the proposition of Joseph Vernet—though after much opposition on account of her sex—a member of the Royal Academy of Painting. She became more than ever the fashion, but left Paris for Italy at the outbreak of the Revolution in 1789, and after a species of triumphal progress through Europe, being admitted a member of the principal academies of painting, including that of St Petersburg, she arrived in London in 1802. There she painted portraits of the Prince of Wales, Lord Byron, and other celebrities. In 1805 she returned to Paris, where she lived until her death (30th March 1842), and where her *salon* was ever the resort of artists, amateurs, and people of fashion. Of unblemished character, of great industry, and of immense charm both of manner and of personal appearance, Madame Vigée Le Brun enjoyed a life-long popularity. Her drawing is correct, her imagination moderate, her colouring delicate, graceful, and pleasing. Her delightful portrait of herself, gay and smiling, now in the Uffizi gallery at Florence, is well known. Many of her best works are in the Louvre gallery in Paris. See her *Souvenirs* (3 vols. 1837), a work illustrated with 662 portraits and 200 landscapes, chiefly taken in England and Switzerland.

Lecece (formerly called TERRA DI OTRANTO), a town of Southern Italy, 7 miles from the Adriatic and 24 by rail SSE. of Brindisi. As Lycia (hence Lecece) it was the seat of a countship in Norman times. Here tobacco, cotton, woollens, and linen are manufactured, and there is a large trade in olive-oil and wine. Lecece has a cathedral and numerous churches, one—St Nicholas—dating from the 12th century. Pop. 22,051.

Lech, a right-hand tributary of the Danube, rises in the Alps in Vorarlberg, flows northward past Augsburg, and after a course of 177 miles joins the Danube a few miles east of Donauwörth. It is a mountain-stream and not navigable. Near Rain, not far from its mouth, the imperialist general Tilly was defeated and killed on 5th April 1632 by the Swedes under Gustavus Adolphus.

Lechler, GOTTFHARD VICTOR, theologian, was born at Kloster Reichenbach in Würtemberg, 18th April 1811, and after various preferments came to Leipzig in 1858 as professor of Theology. There he died 26th December 1888. His first book was a history of English Deism (1841). *The Apostolate and Post-apostolic Times* (1851; 3d ed. 1885) was translated into English in 1886, and *John Wesley and his English Precursors* (1873), by Lorimer, in 1878. He also wrote a history of presbyterian and synodal church organisation (1854), and, with Gerok, a Commentary on Acts (Eng. trans. 1879).

Lecky, WILLIAM EDWARD HARTPOLE, a historian and philosopher, was born near Dublin, March 26, 1838, and educated there at Trinity College, where he graduated B.A. in 1859 and M.A. in 1863. Already in 1861 he had published anonymously *The Leaders of Public Opinion in Ireland*, four brilliant essays on Swift, Flood, Grattan, and O'Connell. Later works were his learned, luminous, and dispassionate *History of the Rise and Influence of the Spirit of Rationalism in Europe* (2 vols. 1865), *History of European Morals from Augustus to Charlemagne* (2 vols. 1869), and *History of England in the Eighteenth Century* (8 vols. 1878-90). The last is not a history in strict chronological form, but rather a philosophical study of events and their causes, relieved by an admirable series of finished historical portraits. Perhaps the ablest and most original portion of the work is the treatment of the American war of independence;

the pages on Ireland are very valuable. A volume of poems (1891) hardly raised his reputation. *Democracy and Liberty* (1896) is anti-Radical in tone. Lecky, who throughout the Home-Rule controversy was a decided Unionist, was elected M.P. for Dublin University in 1895.

Leclair, EDMÉ JEAN, was born at Aisy-sur-Armançon, 100 miles S.E. of Paris, 14th May 1801. First engaged in farm work, and afterwards as a mason's apprentice, he started for Paris, where he arrived friendless and penniless, and apprenticed himself to a house-painter. He proved a capable and industrious workman, and in his twenty-sixth year began business on his own account. By energy and by doing good work he soon secured a large business and took the front rank in the trade. His desire to benefit his workmen and do away with the existing antagonism between employer and employed led him to take M. Frégier's advice, and allow the workmen to participate in the profits of the master. Besides, he compelled people to be honest by issuing pamphlets exposing the tricks of the painting trade by means of which bad and scamped work was passed off for good. He also discovered a method of utilising white of zinc, instead of white of lead, much to the benefit of the workmen's health. His system of Profit-sharing (q.v.), which worked most successfully, was begun in 1842. He died 13th July 1872.

Le Clerc, JOHN, better known as JOHANNES CLERICUS, a Reformed theologian of somewhat free opinions, was born at Geneva, 19th March 1657, made his studies there in philosophy and theology, next repaired to Grenoble, Saumur, Paris, and London, gradually adopted the Remonstrant theology, and became in 1684 professor of Philosophy in the Remonstrant seminary at Amsterdam. In 1728 a stroke of apoplexy robbed him of speech; he died on 8th January 1736. His works were over seventy in number, many of a polemical character. In his controversy with Richard Simon he revealed opinions which were startling then, however innocent now, on the composition and Mosaic authorship of the Pentateuch, and on inspiration generally, and especially as applied to Job, Proverbs, Ecclesiastes, and Canticles. His commentaries on the Bible began with Genesis in 1693, and were not completed till 1731. Another important contribution to its subject was his edition of the Apostolic Fathers of Cotelerius (1698). No less valuable were his serial publications—*Bibliothèque Universelle et Historique* (25 vols. 1686-93), *Bibliothèque Choisie* (28 vols. 1703-13), and *Bibliothèque Ancienne et Moderne* (29 vols. 1714-26).

Lecluse. See CLUSIA.

Lecoq, ALEXANDRE CHARLES, composer of comic operas, was born at Paris, 3d June 1832, and trained at the Conservatoire. From his first successful opera, *Le Docteur Miracle* (1857), he shows Offenbach's influence and tendency. His best known works are *La Fille de Madame Angot* (1872), *Giocofa-Giocofa* (1874), *Le Petit Duc* (1877).

Leconte de Lisle, CHARLES MARIE, a great French poet, was born on the island of Réunion, October 23, 1818. He was carefully educated, and after some years of travel settled to a literary life in Paris. His early enthusiasm for Fourier's dreams soon disappeared before the wisdom learned of experience, but his ardent temperament found a more lasting poetic impulse in Greek ideals and in the sympathetic study of oriental pantheism. He succeeded to Victor Hugo's chair at the Academy in 1886. Besides his original poems he translated Theocritus, Anacreon, the *Iliad* and *Odyssey*, Hesiod, the *Orphic Hymns*, Æschylus, Horace, Sophocles, and Euripides. His *Poèmes*

Antiques (1852) and *Poésies Nouvelles* (1854) he collected as *Poésies Complètes* (1858). Other volumes are *Poésies Barbares* (1862), *Poésies Teu-tyques* (1884), *Derniers Poésies* (1895). He died 17th July 1894. He exercised a profound influence on all the younger poets of his time, and was head of a school called, from their organ, 'Les Parnassiens.' He has a great power of sympathy with the dumb emotion in the life of nature, the vaster aspects of which—the virgin forest, the immense sea, the profound sky—the reader ever feels the presence of, like the ground-plan on which his poetic phantasies are built. He stands aloof from, yet comprehends, the hot emotions that perplex the heart of man, and surveys the drama of the ages not with the eye of a Michelet or a Hugo, but with the calm, unimpassioned intuition of pure intellect. His versification is marked by classic regularity and by serene faultlessness of form.

See the admirable essays by Paul Bourget in *Nouveaux Essais de Psychologie Contemporaine*, and Jules Lenaitre in the first series of *Les Contemporains*.

Lecouvreur, ADELIENNE, actress, was born near Chalons, 5th April 1692, made her debut at the Comédie Française in 1717, and soon became famous for her power as an actress, her fascinations, and the number and eminence of her admirers, amongst whom were Marshal Saxe, Voltaire, and Lord Peterborough. Her death, 20th March 1730, was ascribed to poison administered by a rival, the Duchess Bonillon. This is the plot of the play by Scille and Legouvé, in which Rachel, Sarah Bernhardt, and others have won distinction. See her *Lectures*, edited by Monval (1892).

Lectern (Lat. *lectorium* or *lectricium*), a reading-desk or stand, properly movable, from which the Scripture lessons (*lectiones*), which form portion of the various church-services, are chanted or read. The lectern is of very ancient use, of various forms, and of different materials. The most ancient lecterns are of wood, a beautiful example of which is that of Ramsay Church, Huntingdonshire (about 1450), represented in the woodcut; but they were frequently also made of brass, and often in the form of an eagle (the symbol of St. John the Evangelist), the outspread wings of which form the frame supporting the volume. Sometimes a pelican in her piety takes the place of an eagle.



Lectern.

Lectinary. See LESSONS.

Lectures. At most British universities, lectureships have been endowed for the perpetual dissemination of opinions favoured by the founder; and to these, which were originally almost always of a theological or religious kind, have lately been added some of a wider interest, embracing science, philosophy, archaeology, history, and the like. Among theological lectureships in England of greater or less antiquity are the Bampton, delivered at Oxford; the Hulsean, at Cambridge; the Boyle, at London; the Warburtonian, at Lincoln's Inn;

the Congregational Union lectures, instituted in 1873 in continuation of the former Congregational lectures; and the Hibbert (in comparative religion), at Oxford and London. The Donnellan lectures are given at Dublin; the Baird, Croall, and Cunningham lectures, at Edinburgh. The Fernley lecturers follow the place of meeting of the Wesleyan Methodist Conference. Courses of Gifford lectures on natural religion are delivered at all the Scotch universities, while the Barnett lectures—hardly now to be recognised as identical with the original foundation—are connected with Aberdeen. At Cambridge are the Rede lecture and the Clark lectures in English literature; at Edinburgh, the Rhind in archaeology; while the chief towns in Scotland are visited by the Combe lecturers on physiology, and peripatetic Unitarians of the McQuaker foundation. Distinct from these are such professorships for a fixed period as those of poetry and art at Oxford; the endowed readerships, as in ancient history and the like, at the universities; the courses of lectures given at the Royal Institution or the Edinburgh Philosophical Institution; or endowments for special purposes, as the Harvey, Croonian, and Plumian orations. The Lowell Institute at Boston provides annual courses of free public lectures on religion, science, and the arts, and since its foundation (1839-40) has found audience for many distinguished English as well as American lecturers. See separate articles on the more important of the above lectures.

Lecythidaceæ, a natural order of exogenous plants, or sub-order of Myrtaceæ, the distinguishing characteristic being that the fruit is a large woody capsule, with a number of cells, which in some species remains closed, and in some opens with a lid. All the known species, about forty, are natives of the hottest parts of South America. Brazil Nuts (q.v.) and Sapucaia Nuts (q.v.) are the seeds of trees of this order. The Cannon-ball Tree (q.v.) belongs to it.

Leda, in Greek Mythology, the wife of the Spartan king Tyndareus, whom Jupiter visited in the disguise of a swan. The commonest legend makes her the mother of both Castor and Pollux (q.v.) by the god. The story has supplied a theme for many works of art.

Ledbury, a pleasant, old-fashioned market-town of Herefordshire, 13 miles ESE. of Hereford. It has an interesting church, Romanesque to Perpendicular in style, St. Catharine's Hospital (1232; rebuilt 1822), and a clock-tower (1890) to the memory of Mrs. Browning (q.v.). Pop. of parish (1851) 4264; (1891) 4303.

Ledru-Rollin, ALEXANDRE AUGUSTE, 'the tribune of the revolution of February (1848), as Louis Blanc was its apostle and Lamartine its orator' (Victor Hugo), was born in the house of Scarron at Fontenay, near Paris, 2d February 1807. Admitted to the bar in 1830, he made a name as defender of Republican journalists and men of like views during the reign of Louis-Philippe, and subsequently obtained a great reputation as a democratic agitator and leader of the working-men's party. He was elected in 1841 deputy for Le Mans, and sat of course on the extreme Left. Visiting Ireland at the height of O'Connell's agitation for repeal of the Union, he was present at several of the Liberator's monster meetings, and at Tara was hailed as a delegate from France. In 1846 he published an *Appel aux Travailleurs*, in which he declared 'universal suffrage' to be the only panacea for the miseries of the working-classes. He was an active promoter of the reform-meetings that preceded the commotions of 1848. On the outbreak of the revolution he became a member of the Provisional Government, as minister

of the Interior, and in May was elected one of the five in whose hands the Constituent Assembly placed the interim government. But he offended his supporters, his colleagues, and the moderates by his arbitrary and injudicious conduct, and resigned his portfolio on 28th June. He next ventured on a candidature for the presidency against Louis Napoleon in December, but was ignominiously beaten. An unsuccessful attempt to provoke an insurrection against his fortunate rival, on 13th June 1849, put an end to his political activity and his influence. He fled to England, where he became one of the leaders of the party who sought to control from one centre the democratic agitations throughout Europe, and so give unity and consistency of purpose to their efforts; and he signed the manifestoes of the revolutionary committee along with Kossuth, Mazzini, and Ruge. But in less than a year he published a passionate invective against the land which had given him an asylum. *De la Décadence de l'Angleterre*. For the next twenty years he lived alternately in London and Brussels, being only amnestied in 1870. After his return to France he was elected to the Assembly in 1871, and again in 1874. He died on 31st December 1874, at Fontenay. His *Discours Politiques et Ecrits Divers* appeared in 2 vols. 1879.

Leduc. See VIOLLET-LE-DUC.

Ledum, a genus of plants of the order Ericaceæ, sub-order Rhodoreæ, consisting of small evergreen shrubs, with comparatively large flowers, of which the corolla is cut into five deep petal-like segments. The species are natives of Europe and North America; some of them are common to both. The leaves of *L. latifolium* are said to be used in Labrador as a substitute for tea, whence it is sometimes called Labrador Tea. Sir John Franklin and his party, in the arctic expedition of 1819-22, used in the same way the *Ledum palustre*, which produced a beverage with a smell resembling rhubarb, yet they found it refreshing. The leaves of both these shrubs possess narcotic properties, and render beer heady. They are regarded as useful in agues, dysentery, and diarrhoea.

Lee, ANN. See SHAKERS.

Lee, FREDERIC RICHARD, an English landscape-painter, was born at Barnstaple, Devonshire, in June 1798, and chose the army for his profession. But being obliged by ill-health to quit it, he turned his attention to painting (1818) and was a constant exhibitor at the Royal Academy from 1824 till 1870. He was elected an A.R.A. in 1834 and R.A. in 1838, retiring in 1871. Lee was one of the most thoroughly national painters of his day, the river scenery, parks, leafy lanes, and picturesque villages of his native country forming the favourite subjects of his pencil. He died in Cape Colony, 4th June 1879.

Lee, ROBERT, D.D., was born at Tweedmouth, 11th November 1804, and educated at Berwick (where he was also for a time a boat-builder) and St Andrews. In 1833 he became minister of a chapel of ease at Arbroath; in 1836 he was transferred to Campsie, and in 1843, after the Disruption, to the vacant charge of Old Greyfriars, Edinburgh. In 1846 he was appointed also professor of Biblical Criticism in Edinburgh University, dean of the Chapel Royal, and one of the Queen's chaplains. In 1844 he received his doctorate from St Andrews. In 1857 he began his reform of the Presbyterian church-service. He restored the reading of prayers, as well as the custom of kneeling at prayer and standing during the singing; and in 1863 he introduced a harmonium, in 1865 an organ, into his church. These 'innovations' brought down upon him bitter and harassing attacks, extending over many years; and 'the

Greyfriars case' was still pending before the General Assembly when, on 22d May 1867, Lee fell from his horse in Princes Street, struck with paralysis. He died at Torquay, 14th March 1868.

His works include a *Handbook of Devotion, Prayers for Public Worship* (3d ed. 1863), a *Reference Bible* (1854), *The Family and its Duties* (1863), and *The Reform of the Church* (1864). See *Life* by R. H. Story (2 vols. 1870).

Lee, ROBERT EDWARD, was fifth in descent from Richard Lee of Shropshire, England, who emigrated to Virginia in the reign of Charles I. The ancestor of the Lee family in Virginia received large grants of land located between the Potomac and Rappahannock rivers, known as the Northern Neck, and here he built the original Stratford House, which was burned some years after. In the later edifice, erected by his grandson, Thomas Lee of Stratford, were born the distinguished brothers, Richard Henry Lee (1732-94), mover of the resolution in favour of American Independence and a signer of the Declaration; Francis Lightfoot Lee (1734-97), a signer of the Declaration; and William (1737-95) and Arthur Lee (1740-92), diplomatists. There also, on 19th January 1807, was born the subject of this sketch, the son of General Henry Lee, a cousin of the preceding. At the age of eleven he lost his father, and at eighteen he entered the Military Academy at West Point. He graduated second in his class in 1829, and received a second-lieutenant's commission in the engineers. In 1832 he married Mary Custis, daughter of George Washington Parke Custis, adopted son of George Washington, and grandson of his wife by her first marriage. He became first-lieutenant in 1836, and captain in 1838. At the beginning of the Mexican war in 1846 he was appointed chief-engineer of the central army in Mexico. General Winfield Scott praised him highly in official reports for his services at the siege of Vera Cruz. At the storming of Chapultepec he was severely wounded, and for meritorious services received his third brevet promotion in rank. In 1852 Colonel Lee was in command of the United States Military Academy, and in the three years of his administration greatly improved its efficiency as a training school for officers. His next service was as an officer of cavalry on the Texan border in 1855-59. When on a furlough in October 1859, the time of the John Brown raid, he was put in command of a small force and ordered to Harper's Ferry to capture the insurgents. Colonel Lee was in command of the department of Texas in 1860, but was recalled to Washington early in 1861 when the 'irrepressible conflict' between the free and the slave states seemed imminent. When Lee reached the capital in March 1861, seven states had passed ordinances of secession from the Union, and had formed the Southern Confederacy. Virginia seceded from the Union on April 17, and Colonel Lee, believing that his supreme political allegiance was due to his state rather than to the Union, felt compelled to send his resignation to General Scott, which he did on the 20th of April. The bitter struggle between his personal preferences and his high sense of duty is shown in the words of his wife, written to a friend at the time. 'My husband has wept tears of blood over this terrible war; but he must as a man and a Virginian share the destiny of his state, which has solemnly pronounced for independence.' Within two days after his resignation from the United States army he was made commander-in-chief of the military and naval forces of Virginia.

General Lee was devoutly religious, and a life-

long member of the Protestant Episcopal Church. His purpose to draw his sword only in defence of his native state was modified by its joining the Southern Confederacy, and the change of the capital from Montgomery, Alabama, to Richmond, Virginia. When the Confederate Congress met in Richmond, with representatives from eleven states, in May 1861, five brigadier-generals were appointed, of whom Lee ranked third. He had at first no active command, but remained at Richmond to superintend the defences of the city till the autumn, when he was sent to oppose General Rosecrans in West Virginia. In the spring of 1862 he was sent to supervise the coast defences of Georgia and South Carolina; but when McClellan's 'on to Richmond' advance with 100,000 men was assured, Lee was summoned to the capital. General Joseph E. Johnston, chief in command, was disabled by a wound at the battle of Seven Pines, May 31, 1862, and Lee was put in command of the army around Richmond. The masterly strategy displayed by Lee, and the desperate fighting of his army in the famous seven days' battles around Richmond, defeated the purposes of McClellan's Peninsular campaign, and belong rather to the history of the war than to personal biography. The same may be said of his battles and strategy in opposing General Pope's movements, his invasion of Maryland and Pennsylvania, and other prominent events of the war. The increasing resources of the North and the decreasing resources of the South could only result in the final success of the former. It was no news to Lee to be told of 'the hopelessness of further resistance' by General Grant in his note of April 7, 1865, and the common desire of both commanders 'to avoid useless effusion of blood' was creditable to both. On April 9, 1865, Lee surrendered his army of about 27,805 men to General Grant at Appomattox Courthouse, Virginia, and the four years' war was practically ended. That General Lee undertook ill-judged movements, as his advance into Pennsylvania, and that he trusted too much to his lieutenants in matters of importance, has been the opinion of some critics; and probably his unwillingness to throw blame on government officials who planned, and on subordinates to whom he entrusted the execution of the plans or parts of them, has given more apparent than deserved grounds for such criticisms. After the close of the war he frankly accepted the result, and although deprived of his former property at Arlington on the Potomac, and the White House on the Pamunkey, he declined proffered offers of pecuniary aid, and accepted the presidency of Washington College, since called the Washington and Lee University, at Lexington, Virginia. Here he devoted himself assiduously to the proper duties of a college president, gaining the affectionate esteem of the faculty and students as he had of the officers and soldiers of two armies in former years.

Exposure in the field in 1863 had resulted in rheumatic inflammation of the pericardium, which became more painful and frequent from exposure to cold or violent exercise, till a severe attack in 1869 greatly impaired his heart's action. From a second attack, in September 1870, he did not recover, but grew weaker till his death, October 12, 1870. His widow died in Lexington, Virginia, November 6, 1873. General Lee had three sons and four daughters. The eldest son, George Washington Custis Lee, graduated at the head of his class at West Point in 1851, resigned as first-lieutenant in the United States army in 1861, was an aide-de-camp to Jefferson Davis, 1861-63, major-general of a division of the army of northern Virginia in 1864, and successor of his father as president of the Washington and Lee University in 1871. William Henry Fitzhugh Lee, the second

son, was an officer in the United States army, and major-general of cavalry in the Confederate army. He was elected to the 50th and 51st congresses. Captain Robert E. Lee of the Confederate cavalry was the third son.

A bronze equestrian statue of General Lee, by Mercie of Paris, erected mainly by the women of the South, was unveiled in Richmond, Virginia, in 1890. The height of the whole structure, including an elaborate monumental pedestal, is 61 feet 2 inches, the equestrian figure being 22 feet 2 inches. See the *Life* by J. E. Cooke (1871), that by Long (1887), and that by his nephew, Fitzhugh Lee (1894).

Lee, SAMUEL, an English orientalist, was born, 14th May 1783, at Longnor, in Shropshire, studied at Queen's College, Cambridge, in 1819 was chosen professor of Arabic, and in 1831 regius professor of Hebrew, and died rector of Barley, in Hertfordshire, 16th December 1852. His reputation rests upon a *Grammar of the Hebrew Language* (1827); *Book of Job, translated from the Original Hebrew* (3 vols. 1837); *Hebrew, Chaldee, and English Lexicon* (1840); a translation from the Arabic of the *Travels of Ibn-Batuta* (1833) and from the Syriac of the *Theophrastus* of Eusebius (1843). He also wrote *Sermons on the Study of the Holy Scriptures* (1830), *Events and Times of the Visions of Daniel and St John* (1851), and an *Inquiry into Prophecy* (1849). He took charge, for the British and Foreign Bible Society, of editions of the Syriac Old Testament, the Syriac New Testament or Peshito, the Malay, Persian, and Hindustani Bibles, and the Psalms in Coptic and Arabic.

Leech, JOHN, humorous draughtsman, was born, of Irish descent, in London, 29th August 1817, his father, a cultured and excellent man, being landlord of the London Coffee House, Ludgate Hill. He was educated at the Charterhouse, where he was a fellow-pupil of Thackeray's, his friend throughout life, who at school was deemed the better caricaturist of the two, and who afterwards published an admirable estimate of Leech's art (*Quarterly Review*, December 1854). He next studied medicine and surgery, and during his attendance at St Bartholomew's Hospital his artistic skill found exercise in the production of anatomical drawings. Before long he adopted art as a profession, and at the age of eighteen published *Etchings and Sketchings, by A. Pen, Esq.* About 1838 he was contributing to *Bell's Life*; and in the fourth number of *Punch*, 7th August 1841, we find his first contribution to the journal with which his name is most closely associated, and with which he was connected till the time of his death. The cartoons which he designed for *Punch*, especially those dealing with incidents in the political life of Lord Brougham, Lord Palmerston, and Lord John Russell, and the powerful and terrible 'General Février turned Traitor,' are full of high qualities, and have been published separately. But even more delightful are the smaller woodcuts, drawn easily and freely, and dealing in gently humorous fashion with subjects of everyday life. In these, as it has been truly said, 'he has entered with genial sympathy into every phase of the many-sided English life of the hunting-field, the seaside, the ballroom, the drawing-room, and the nursery,' 'he has turned caricature into character, and left behind him not a little of the history of his time and its follies sketched with inimitable grace.' Various series of these designs have been collected in volumes entitled *Pictures of Life and Character from the Collection of Mr Punch*; and in 1862 a collection of them, enlarged by a mechanical process, and coloured by the artist himself in a combination of oil- and water-colours, was brought

together in the Egyptian Hall, London, and formed an exceptionally popular exhibition. In the intervals of work for *Punch* Leech contributed much to other journals and publications, including woodcuts in *Once a Week* (1859-62) and *The Illustrated London News* (1856), in *The Comic English and Latin Grammars* (1840), *Hood's Comic Annual* (1842), *Smith's Nassau Boat* (1843), *A Little Tour in Ireland* (1859); etchings in *Bentley's Miscellany* and *Terrill's Shilling Magazine*, in the Christmas books of Dickens, the *Comic History of England* (1847-48), the *Comic History of Rome* (1852), and the *Handley Cross* sporting novels; and also drew several lithographed series, of which *Portraits of the Children of the Mobility* (1841) is the most important. At length the artist's health began to suffer from incessant overproduction, he fell into a state of nervous irritability and prostration, and died at Kensington, 29th October 1864. See Dr John Brown's *John Leech* (1882), F. G. Kitton's *Biographical Sketch* (1883), and the *Life* by W. P. Frith, R.A. (1891).

Lee-Chee. See LITCHI.

Leeches (A.S. *læc*, 'a physician'; *Hirudina* or *Discophora*), a class of worm-like animals, usually suctional parasites, sometimes genuinely carnivorous. They are widely distributed in fresh and salt water, and occasionally on land. The body is extensible and ringed, but the superficial rings do not correspond to the true segments; no appendages are present, but there is a posterior attaching sucker, and the mouth is powerfully suctional; the body-cavity is almost obliterated by a spongy growth of connective tissue; the animals are hermaphrodite.

The Medicinal Leech (*Hirudo medicinalis*), formerly much used in blood-letting, has a slightly flattened body 2 or 3 inches in length, greenish black in colour, mottled on the under side, and with six rows of reddish and yellowish spots along the back. The skin is slimy and frequently casts its cuticle; there are 102 superficial skin-rings, with sense-spots on every fifth, while ten distinct eye-spots are borne on the head.

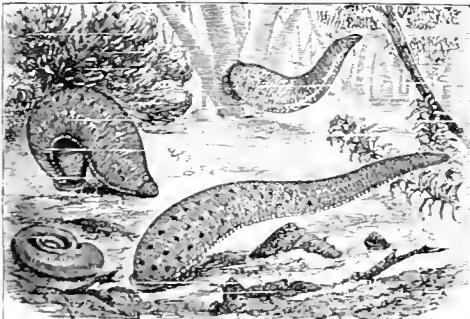

The Medicinal Leech (*Hirudo medicinalis*).

The animal is very muscular, moves rapidly by alternately fixing its oral and posterior suckers, and swims with graceful undulations. The mouth contains three semicircular 'saws,' each with eighty to ninety minute teeth of lime and chitine, by the saw-like action of which the leech gives its characteristic triadate bite. From animals thus bitten the leech sucks blood, and falls off when its many-pouches gut is gorged. A secretion from the pharynx seems to keep the blood from coagulating, and after a heavy meal the leech can fast and digest for a year. Its opportunities are in many circumstances few and far between, but it certainly makes the most of them. About the

leech's own blood, it is worth noting that it is coloured red with hæmoglobin. Leeches are at home in slow streams and in marshes, sometimes venturing ashore in search of victims higher than the insect larvae, fishes, and amphibians which they may hit upon in the water. The eggs are laid about June in the moist ground by the side of the water, and are enclosed in cocoons which are secreted from the skin. The growth of the young leech is slow, may continue in fact for four or five years, while the total length of life sometimes reaches a score. The medicinal species occurs in Britain, but is much commoner on the Continent. When the medical use of leeches, which is of ancient origin, was a constant practice, the swamps of western France were very important sources of supply. There the vampires were sometimes fed by driving old horses or cattle into the enclosures, and the primitive custom of wading in the water till the leeches fix on the bare legs is still practised by collectors. It is calculated that thirty millions used to be employed annually for medical purposes in France and England, but nowadays they have gone much out of fashion; yet a hatchery near Hildesheim still raises some 3½ millions annually. When kept by apothecaries they ought to be allowed free play in a closed glass aquarium with water-plants, instead of being huddled together in a dark vessel.

Leeching, or the application of leeches for the purpose of abstracting blood, is sometimes used instead of venesection, where general depletion is indicated, particularly in children; but much more often for the purpose of local depletion in localised inflammations. In the diseases of infants and young children, leeches must be applied with caution. In applying leeches the part should be thoroughly cleaned, and the leeches, after being dried by rubbing them in a clean linen cloth, should be placed in an open pill-box, or in a wine-glass, and applied to the spot at which it is desired that they should attach themselves. When it is wished to affix a leech to the inside of the mouth, it is placed in a narrow tube called a leech-glass. When the animals will not attach themselves readily they may sometimes be induced to bite by moistening the part with milk or blood. They usually drop off when filled; if they do not, they may be induced to do so by sprinkling them with common salt; they must never be pulled away. The quantity of blood which a leech is capable of drawing may be estimated on an average at about a drachm and a half, besides what flows from the wound after it has fallen off. It is usually desirable to promote to some extent this flow, which is readily done by the application of warm fomentations or poultices. The bleeding generally stops spontaneously after a short time; if it goes on longer than is desirable, the application of the fluff of a hat, or of a bit of cobweb, will usually check it. If these means fail, a little cone of lint should be inserted into the bite, over which a compress should be laid and a bandage applied; or the bite should be touched with a stick of nitrate of silver (lunar caustic) scraped to a point. Leeches, when applied to the mouth or interior of the nose, have been occasionally swallowed, and have given rise to very unpleasant symptoms. A moderately strong solution of common salt readily dislodges them. The 'artificial leech,' sometimes used, is a mechanical arrangement for producing a small freely-bleeding wound in the skin.

The Horse-leech (*Hirunopus sanguisuga*), whose 'daughters' (whether of this precise species or not) 'cry Give, give,' is common in Britain and elsewhere. It is about 4½ inches in length, feeds largely on earthworms, but has blunt teeth, and is not used medicinally. Another horse-leech is the

voracious *Anastoma*, which is carnivorous rather than parasitic. Among the numerous land-leeches which attack horses, cattle, and men, one of the most troublesome is *Hermodipsa erylonica*, graphically described by Sir James S. Tennent. It is only about an inch long and as thin as a knitting-needle, but it pursues its desired victims with considerable rapidity, and makes itself most irksome both to man and beast. So abundant are land-leeches in some warm and moist parts of the East



Horse Leech.

that soldiers and workmen are sometimes fatally weakened by the minute but persistent blood-letting. All the above and some other genera, such as the eight-eyed *Nepheleis* of our ponds, are called Gnathobdellidae, being usually provided with three tooth-plates, but without a 'proboscis.' In another set, Rhynchobdellidae, the forepart of the body is retractile and forms a proboscis. Here are included many interesting forms: the little fresh-water *Clepsine*, sometimes found with the young attached to the parent; the large, warty, marine *Pontobdella*, which fastens on rays; *Piscicola* on fresh-water fishes, such as perch and carp; and *Branchellion*, with numerous lateral leaflets of skin. The largest leech known is the South American *Macrobdella valdiviana*, a carnivorous form living in moist earth, and sometimes said to measure two feet and a half.

See C. O. Whitman in *Quart. Jour. Micr. Sci.* for 1886; Moquin-Tandon, *Monographie de la Famille des Hirudinées*, with Atlas (21 ed. 1846); Verill, *Fresh-water Leeches* (Washington, 1875).

Leeds, the first town in Yorkshire, and fifth in England in point of population, is a parliamentary and municipal borough, returning since 1885 five members to the House of Commons. By rail it is 25½ miles SW. of York, 196 N.W. of London, and 112 S.E. of Carlisle. It is situated in the north-west of the West Riding of Yorkshire, in the valley of the Aire, and is the seat of important manufactures, especially of clothing in all its branches. The ready-made clothing industry, especially, gives employment to more hands than anything else. The woollen trade carried on here, and in the surrounding towns and villages, exceeds in extent that of any other part of England. It has been estimated that general goods to the annual value of £11,000,000 pass through the warehouses in Leeds. The iron industries, which have been largely developed, employ about 30,000 persons, and are now as important as the woollen manufactures. The manufacture of leather is carried on in some of the largest tanneries in the kingdom, and about 100 firms are engaged in making boots and shoes. The other chief manufactures are those of loco-motives (both for rail and tramway), agricultural machines, glass, paper, tobacco, oil, chemicals, earthenware, worsted, and silk. Formerly flax-spinning was extensively carried on, but it is now fast dying out. It will thus be seen that Leeds depends for its prosperity not upon any one staple industry, but upon the great variety of its manufactured products. The goods traffic by rail, canal, and river is immense.

There are thirty-four churches in Leeds, eight Roman Catholic and about eighty dissenting places of worship. The chief church is St Peter's, which is in Kirkgate, and was rebuilt in 1838 at a cost of £29,770. It is 180 feet long by

86 wide; the tower is 139 feet high, and contains a peal of thirteen bells. The church also contains some fine monuments, one of which was erected in memory of those natives of Leeds who fell in the Crimea. The most interesting church in the town is St John's, New Briggate, consecrated by Archbishop Neile in 1634, an almost unique example of a 'Laudian' church, and still retaining the original fittings. The other principal buildings are chiefly of recent erection. The town-hall, completed in 1858, is 250 feet long, 200 feet broad, and the tower is 225 feet high. It covers 5600 square yards. The great hall is 161 feet long, 72 feet wide, and 75 feet high. It is richly decorated, and contains one of the largest and most powerful organs in Europe, besides statues of Edward Baines and Robert Hall, formerly members for the borough. There are also colossal statues of Queen Victoria and the Prince Consort in the vestibule, and of Wellington in the front of the building. Contiguous to the town-hall are the municipal buildings (comprising, besides the various corporate offices, reading-room, free library, and fine art gallery), and the school-board offices, the whole forming two handsome and substantial blocks of buildings.

The General Infirmary was erected in 1868 from designs by Sir G. G. Scott, at a cost of £120,000, and contains accommodation for 300 in-patients. The mechanics' institute, erected in 1867 at a cost of £25,000, contains a lecture-hall accommodating 1700 persons. The grammar-school, built in 1859, at a cost of £13,000, from designs by Barry, is a cruciform Decorated structure. Other buildings are the Coin Exchange, a handsome structure of an oval form; the new post-office (fronting the handsome City Square); the Yorkshire Penny Bank; Brown's Bank; the Coliseum, the most convenient public hall in the town; the Philosophical Hall, with a fine museum; the Wesleyan training-college, erected in 1868; Turkish Baths (cost £14,000); Beckett's Bank, a fine work by Sir G. G. Scott. There is also a library of 80,000 volumes, founded by Priestley in 1768. Among charitable institutions may be mentioned the Dispensary; Hospital for Women and Children; Tradesman's Benevolent Society; Industrial Schools; Convalescent Home; a handsome work-house; the Reformatory at Adel, where about sixty juvenile criminals are usefully employed in agricultural and other occupations. Leeds has also a Royal Exchange, which was opened in 1875, a Stock Exchange, two general markets—one of which is a handsome structure of iron and glass—a new cattle-market, white cloth hall, three terminal railway stations giving access to seven railway companies, eleven banks, and four theatres. The old coloured cloth hall was pulled down in 1889. The Yorkshire College, an important centre of higher education established in 1874, has now nearly forty professors and instructors in its two departments of science, technology, and arts and of medicine; it is affiliated to the Victoria University. A large and imposing pile of Gothic buildings was devoted to its use in 1885; the new School of Medicine, opened in 1891, cost £40,000. Some sixty Board schools, accommodating 65,000 children, have been erected since 1870, including the Central Higher Grade School for 2000 scholars, opened in 1889, and the Southern Higher Grade School. A complete system of tram lines radiates from the centre of the town to all the outlying suburbs, electricity (on the trolley system) being the motive-power. Kirkstall Abbey (q.v.) is about 3 miles from Leeds. Roundhay Park, 3 miles from Leeds, was bought by the corporation in 1872 at a cost of £140,000, and converted into a recreation ground for the

use of the public. Adel Church, about 4 miles from Leeds, was erected 1140. Near it have been found remains of a Roman station. Pop. (1851) 172,270; (1881) 309,112; (1891) pop. of borough—since 1888 a county borough—367,505. Since 1893 the mayor is styled Lord Mayor.

Amongst Leeds worthies are Dean Hook (q.v.), who was vicar of Leeds; Priestley, theologian and chemist; Cope and Rhodes, the artists; the Teales, physicians, &c.; besides the Becketts, the Baines's, the Gotts, the Fairbairns, the Denisons, the Kitsons, and other prominent families, which have been closely identified with the interests of the town, and whose members have been noted for their public spirit and philanthropy. Among the books on Leeds may be mentioned Ralph Thoresby's *Ducessus Leodienis*, or *Topography of Old Leeds* (1715); Baines's *Historic Sketch of Leeds* (1822); and Jackson's *Guide to Leeds* (1889).

Leeds. THOMAS OSBORNE, DUKE OF, better known in history as Earl of Danby, English statesman, was the son of a Yorkshire baronet, and was born in 1631. He entered parliament for York in 1661 as a warm supporter of the king and of the Established Church. He first held office in 1667 as an auditor of the Treasury; after that his promotion was rapid: in 1671 he was appointed Treasurer of the Navy, in 1673 Viscount Latimer and Baron Danby, and in 1674 Lord High Treasurer and Earl of Danby. He endeavoured to enforce the laws against Roman Catholics and Dissenters; and, though he disliked French aggression, and so far favoured the Dutch party that he effectively used his influence to get Princess Mary married to William of Orange in 1677, he lent himself to be the agent of Charles, and on his behalf negotiated with Louis XIV. for bribes to the English king. Louis, however, intrigued successfully for Danby's downfall: the Commons impeached him in 1678 on six different counts, the chief of which were treating traitorously with foreign powers without the consent of council, aiming at the introduction of arbitrary power, and squandering public money. He was not brought to trial, but kept in the Tower until 1683, although Charles gave him at once a full pardon. This the Commons refused to recognise, and, in spite of a dissolution, still persisted in the impeachment. Danby is chiefly remembered in history for the part he played at the revolution of 1688. When James began to threaten the Established Church Danby returned to active political life. He signed the invitation to William of Orange and secured York for him. His reward was a rise in rank from earl to marquis (of Carmarthen) and the presidency of the council, virtually the chief place in the government. But he again bribed as he had done during his first administration, and practised the same unscrupulous methods of government. He was created Duke of Leeds in 1694. But in 1695 he was impeached a second time, for having himself accepted 5000 guineas from the East India Company as the price of his influence in securing an extension of their chartered privileges. He again managed to stave off condemnation; but his power was now virtually gone, and in May 1699 he finally retired. After that his principal public appearance was to speak in defence of Sacheverell in 1710, when he stultified himself by condemning the principle of the revolution. He died at Easton, in Northamptonshire, on 26th July 1712. See *Life* by T. P. Courtenay (1838).

Leek (*Allium Porrum* of some; see ALLIUM), a biennial plant, believed now by many of the best authorities to be a cultivated variety of the British species *Allium Ampeloprasum*, a well-known biennial species of the Onion family, much esteemed

for culinary purposes. In gardens much attention is given to its cultivation. The more liberal the culture the more delicate and tender is the produce; therefore it is generally grown in trenches, which have a liberal supply of manure dug into them in the same way as celery. The stems are blanched by earthing up, which increases their delicacy. Scotland is famous for the splendid quality of its leeks, and Musselburgh is the centre in which the most approved kinds are grown for seed-saving. Seeds grown there have a special commercial value, which is due entirely to care, year after year, in selecting only the best types for the purpose of seed-saving. St David, patron saint of Wales, is credited with having advised the Britons, on the eve of a battle with the Saxons, to wear leeks in their caps, so as easily to distinguish friends from foes, and thus to have helped to secure a great victory. Hence the Welsh custom of wearing leeks in their hats on St David's Day. See Shakespeare's *Henry V.*

Leek, a manufacturing and market town of Staffordshire, on the Churnet, 13½ miles SSE. of Macclesfield, and 24 NNE. of Stafford. The parish church, dating from 1180, but mainly decorated in style, was restored by Street in 1867-75. There are also a grammar-school (1723), a cottage-hospital (1870), and, 1½ mile distant, the ruined Cistercian abbey (1214) of Dieulaeres (De la Croix). Leek manufactures sewing and embroidery silks, and is the chief English centre for dyeing silk (see SILK). The Nicholson Institute comprises a Free Library, and Art School, &c. Pop. (1851) 1877; (1891) 12,760. See Sleight's *History of Leek* (2d ed. 1884), M. H. Miller, *Old Leek* (Leek, 1891).

Leer, a commercial town and port on the Leda near where it enters the Ems, in the Prussian province of East Friesland, 32 miles NW. of Oldenburg. Pop. 10,399.

Leet. The court leet, in England, was a court of a manor, township, &c. for election of certain officers and trial of minor offences. The importance of these courts is now very small, but there are manors, &c. where they are regularly held.

Leeuwarden, capital of the Dutch province of Friesland, stands on the Harlingen and Groningen Canal, 113 miles by rail NNE. of Utrecht. It contains handsome law-courts and town-hall, has an ancient palace of the Princes of Orange, a library with valuable archives, and a dozen churches. Linen fabrics, mirrors, pianofortes, and wagons are manufactured. Leeuwarden is one of the largest fruit and cattle markets in Holland, and does considerable trade in agricultural produce, groceries, wine, and brandy. Pop. (1873) 27,108; (1896) 31,598. In the 13th century it was situated on an arm of the sea, which subsequently sanded up. See Havard, *Dead Cities of the Zuider Zee* (1876).

Leeuwenhoek, ANTON VAN, one of the most successful pioneer microscopists, was born at Delft on 24th October 1632, enthusiastically pursued microscopic work with self-made instruments in 1654, made many important discoveries, and died at Delft on 27th August 1723. He supplemented Harvey's discovery of the circulation of the blood by tracing the capillaries in the frog's foot, defined the red blood-corpuscles of Vertebrates, was the first to notice definitely what are now called unicellular organisms, and corroborated, though with erroneous interpretation, the discovery of male elements or spermatozoa by his student Ludwig Hamm. His investigations of minute structure led him to detect the fibres of the lens, the fibrils and striping of muscle, the structure of ivory and hair, the scales of the epidermis, the distinctive characters of Rotifers, and many interesting histo-

logical facts in regard to insects. Much of his time and attention was given to a long series of investigations into spontaneous generation, of which theory he was a decided opponent. In the course of these studies he ascertained and proved, amongst other results, that oak-galls are primarily caused by the development of an insect's egg deposited in the bark; that weevils are hatched, not *from* wheat, but from an insect's eggs deposited in wheat; that the flea is propagated in a similar manner to other insects, not originated from dust, or sand, or the dung of pigeons, as was commonly believed; that Aphides are viviparous; that oels, instead of being produced from dew, are likewise viviparous; and that muscels are not generated from mud or sand, but from spawn. He also extended his inquiries to the growth of trees, and showed the differences that exist in the structure of the stem of monocotyledons and dicotyledons. The greater part of his discoveries and investigations were described in papers (112) contributed to the *Philosophical Transactions* of the Royal Society and papers (26) printed in the *Memoirs of the Paris Academy of Sciences*, of both which bodies Leewenhook was a member. The most complete collection of his *Works* appeared at Leyden in 4 vols. in 1719-22. A selection of these was translated into English by S. Hoole (2 vols. Lond. 1798-1801). See the *Life in Dutch* by Haaxman (Leyden, 1875).

Leewin, CAPE, the south-west corner of Australia, notable on account of the tempestuous weather usually encountered there.

Leeward Islands. See ANTIGUA, WEST INDIES.

Lefebvre, FRANCOIS JOSEPH, Duke of Danzig and Marshal of France, was born at Ruffach, in Alsace, 25th October 1755. He entered the army at the age of eighteen, and was a sergeant in the French Guards when the Revolution broke out. He was engaged for some time on the Moselle and Rhine, fought at Flenrus, Altenkirchen, and Stockach, and rose in rank with wonderful rapidity. In 1799 he took part with Bonaparte in the overthrow of the Directory, and in 1804 was made a Marshal of the Empire. He also conducted the siege of Danzig, and after its capture was created Duke of Danzig. He distinguished himself in the early part of the Peninsular war, and suppressed the usurpation in the Tyrol. During the Russian campaign he had the command of the Imperial Guard, and in 1814 of the left wing of the army which resisted the advance of the allies in France. Submitting to the Bourbons after Napoleon's abdication, he was made a peer, a dignity restored to him in 1819, though he had sided with his old master during the Hundred Days. He died in Paris, 11th September 1820.

Lefkolia. See NICOSIA.

Lefort, FRANCOIS JACOB, favourite of Peter the Great, was born at Geneva in 1653, being descended from a family of Scottish extraction which had settled in Piedmont, afterwards (1585) in Switzerland. He served for a time with the Swiss Guard at Paris; but went to Russia in 1675, and attracted the notice of Prince Galizin, who made him a commander of the new troops raised to counteract the influence of the 'strelitzes' or old militia. Having taken a leading part in the intrigues which made Peter sole ruler after the death of his brother Ivan, Lefort was advanced to be first favourite of the czar, and next to him the most important personage in Russia. A man of great ability, Lefort backed up Peter in his projects of reform, remodelled the army and laid the foundation of the navy, and in 1694 was made admiral and generalissimo. When Peter undertook his visit to foreign countries in 1697 Lefort

was made chief of the embassy in the train of which the czar travelled *incognito*. He died 12th March 1699. See LIVES (in German) by Posselt (1866) and Blum (1867).

Left-handed. See RIGHT-HANDEDNESS; BRAIN, Vol. II, pp. 391, 392.

Leg, the lower limb, or, in the usage of anatomists, that part of the lower extremity which lies between the knee and the ankle. It consists of two bones, the Tibia and Fibula (see SKELETON, FOOT), and of masses of muscles (together with nerves and vessels) which are held in position by coverings of fascia, and are enveloped in the general integument. The shaft of the tibia is of a triangular prismoid form, and presents three surfaces and three borders. The internal surface is smooth, convex, and broader above than below; except at its upper third, it lies directly under the skin, and may be readily traced by the hand. The external and the posterior surfaces are covered by numerous muscles. The muscular mass forming the calf (formed by the *gastrocnemius*, *soleus*, and *plantaris* muscles) is peculiar to man, and is directly connected with his erect attitude and his ordinary mode of progression. The anterior border of the tibia, the most prominent of the three, is popularly known as the *shin*, and may be traced down to the inner ankle. The fibula, or small bone of the leg, lies on the outer surface of the tibia, and articulates with its upper and lower extremities, and with the astragalus inferiorly. It affords attachments to many of the muscles of this region.

This region is nourished by the anterior and posterior tibial arteries into which the popliteal artery divides. Both these arteries occasionally require to be tied by the surgeon in cases of wounds or aneurism. The blood is returned towards the heart by two sets of veins—the deep, which accompany the arteries, and the superficial, which are known as the internal or long saphenous, and the external or short saphenous veins. These superficial veins are very liable to become permanently dilated or varicose (see VARICOSE VEINS), if there is any impediment to the free transmission of the blood, or even from the mere weight of the ascending column of blood, in persons whose occupation requires continuous standing. The nerves of the leg, both sensory and motor, are derived from the great sciatic nerve and from its terminal branches, the internal popliteal and the external popliteal or peroneal nerve.

In cases of fracture or *broken leg* the two bones are more frequently broken together than singly, and the most common situation is at the lower third. What is known as Pott's fracture consists of fracture through the lower third of the fibula, with fracture of the projecting lower end of the tibia.

Ulceration of the leg is a frequent consequence of varicose veins, and the very condition which causes the veins to dilate (continuous standing) is an effectual preventative of the healing process, to ensure which complete rest, with the leg raised so as to assist the return of the blood, is necessary.

Bandy, or bow, leg is a condition which may appear as the result of muscular contraction before a child has been placed on its feet. In such a case the natural curve of the tibia is merely exaggerated. It is associated with Rickets (i.e. a deficiency of lime salts), in which the child has the habit of sitting tailor-wise, and thus bending the tibia forwards and outwards in its lower third. Sometimes one leg is bandy and the other is kneed. This is produced in a soft-boned child by the mother or nurse always carrying the child upon the same arm and using the other arm to clasp the child's legs across the front of her body. See FOOT, KNEE,

HIP-JOINT, CLUB-FOOT, ACHILLES TENDON, &c.; also AMPUTATION, ARTIFICIAL LIMBS.

Legacy is a bequest or gift of personal property by will. In England it is provided by the Will-Act of 1837 that if a legacy is given to the witness of a will, or to his or her wife or husband, the legacy is void; also bequests to superstitious uses are void, as, for example, to maintain a priest, or an anniversary or obit, or a lamp in a church, or to say masses for the testator's soul, or to circulate pamphlets inculcating the pope's supremacy. Legacies of money for charitable purposes, as for the use of schools, churches, &c., are valid, but if the money is directed to be laid out in the purchase of land for such purposes the legacy is void by what is called the Mortmain Acts (amended and consolidated by the Mortmain and Charitable Uses Act, 1888). Certain favoured institutions and charities are exempted from the operation of these acts.

Legacies are divided into *specific*, *general*, *demonstrative*, and *cumulative*. A *specific* legacy means a legacy of a definite thing, as a particular horse, picture, silver-plate, &c., or a sum of stock in the funds. A *general* legacy means a sum of money, without it being stated out of what fund it is to come, and it is payable out of the assets generally. The important difference between these two kinds of legacy is this, that if the subject-matter of the specific legacy fail, as if the horse die or be previously sold, &c. (ademption), the legacy is gone, and no compensation is given for it after payment of the testator's debts. But legacies given for valuable consideration do not suffer abatement; while, on the other hand, if there is not enough to pay all the general legacies, then they must abate—i.e. share the loss—whereas the specific legacy, if it exist, must still be paid in full. A *demonstrative* is something like a general legacy, but a particular fund is named from which it is to be satisfied. It is not liable to ademption by any act of the testator, nor is it liable to abatement with general legacies as long as it does not exceed the fund from which it is to be paid. A *cumulative* or *substitutional* is a second legacy given to the same person, and the question for settlement in that case is whether the later gift is in addition to or in place of the first. A legacy is not payable by the executor till a year has elapsed after the testator's death, for it is presumed he requires this time to inquire into the state of the property; and this is true even though the testator has ordered the legacy to be paid within six months after the death. If a legacy is left to an infant under twenty-one it cannot be paid to the father or any other relative without the sanction of the Court of Chancery. Formerly, if a legacy was left to a married woman the husband was entitled to claim it, unless it was left to her separate use, or unless she was unprovided for by the husband; but now in all cases the wife gets for her separate use all property coming to her. Interest is due on legacies from the time when the principal sum is payable—i.e. one year after the death unless otherwise specified. If the legatee die before the testator the legacy lapses—i.e. becomes void; but there are some exceptions, as where the legatee is a child or grandchild of the testator. A legacy to a creditor, if equal to or greater than the debt, is presumed to be in satisfaction thereof. If the estate from which a legacy is claimed do not exceed £500, an action to compel payment may be brought in the county court. The person to whom the remainder of the property is left after all claims are discharged is called the residuary legatee. In Scotland the rules as to legacies are mainly the same, but a verbal legacy up to £100 Scots (£8, 6s. 8d.) is valid. In Scotland a legacy can be enforced in six months

after the testator's death, and bears interest at 5 per cent. from such death. If a legacy is left to a married woman, the property in it vests in her; she can enjoy the income, but cannot dispose of the corpus without the concurrence of her husband.

In the United Kingdom, where the whole personal estate is under £100 there is no legacy duty, and for under £300 the fixed inventory duty of 30s. 'is deemed to be a full satisfaction of any claim to legacy duty.' In other cases the rate is inversely as the degree of relationship. The husband or wife of the testator pays no duty; the child or lineal descendant, a parent or lineal ancestor, pays 1 per cent.; a brother or sister, or their descendants, 3 per cent.; others, in proportion to their remoteness, 5 and 6 and 10 per cent. The last is in all cases the maximum rate. The royal family are exempt from legacy duty. See Jarman on *Wills*, and Williams on *Executors*.

Legal Fiction. See FICTION.

Legal Tender. See TENDER.

Legate, the name of the ambassador or representative, whether temporary or permanent, sent by the pope to a particular church. In the later constitution of the church three classes of legates are distinguished: (1) *Legati a latere*, 'legates despatched from the side' of the pontiff, who are commonly cardinals; (2) *Legati missi*, called also 'apostolic nuncios,' and including a lower grade called 'internuncios;'; (3) *Legati nati*, 'legates born,' whose office is not personal, but is attached by ancient institution or usage to the see or other ecclesiastical dignity which they hold. Of the last class there were examples in most national churches; thus, the Bishop of Thessalonica was legate born for Illyrium, the Bishop of Arles for Gaul, the Bishop of Mainz for Germany, the Bishop of Toledo (though his claim was often disputed) for Spain, the Archbishop of Canterbury for England, &c. This institution, however, has gone entirely into abeyance; and, indeed, the authority of legates is much modified in the modern church. In the medieval times the legate claimed full papal jurisdiction in the country assigned to him, even overruling the local jurisdiction of the bi-shops of the national church. This led to many disputes; to refusals to receive legates, as in France, where the legate was obliged to wait at Lyons till his credentials should have been examined and approved at court; and to counter legislation, as in England to the statute of 16 Richard II., commonly known as the Statute of Premunire. The Council of Trent removed the ground of contention by abolishing all such claims to local jurisdiction as trench upon the authority of the bishops. The legate, in the modern church, is little other than the ambassador, mainly for spiritual purposes, of the pope. He is held as belonging to the diplomatic body, and by the usage of Catholic courts enjoys precedence of all other ambassadors. The legates at the more important courts have the title of *nuncio*, at minor courts of *internuncio*. In 1890 there were apostolic nuncios at Vienna, Munich, Madrid, Paris, Lisbon; internuncios at the Hague and Rio Janeiro, and an apostolic delegate at Quito. In the States of the Church (q.v.) the governors of the Legations were called *legates*.

Legato (Ital., 'tied'), in Music, means that the passage is to be performed in a smooth manner, the notes being played as if bound or tied together, or in such a manner that the one note is as it were rounded off, or flows into the following one.

Legend, a name somewhat loosely applied on the one hand to the creations of mythology, and on the other to the more or less historical accretions that ever tend to grow around the names of heroes

who impress the popular imagination. Interesting examples of entirely baseless legends in their turn becoming historical may be seen under the names Pope Joan and William Tell. It is ever the fate of a great name to be enshrined in fable, and this fact afforded a basis for Strauss in his famous attempt to reconstruct the history of Christianity. The term legend was early applied to those religious traditions which, in the early days of Christianity, clustered round the gospel history; this tendency to mythic embellishment having further showed itself in connection with the later saints and martyrs. This curious practice of interweaving truth with fable no doubt arose from a credulous love of the wonderful, an exaggeration of fancy, and an ecclesiastical enthusiasm, at times even pious fraud helping to disseminate such embellished and unreliable narratives. But, intermixed with falsehood as these so-called legendary tales were, they gradually crept into the Eastern and Western Churches, and in the course of centuries gained an entrance into the national literature of Christian nations. Already the same process had made the *Talantol* the strange medley of sense and nonsense that it is. It should be added that, in the Roman Catholic Church, the lives of saints and martyrs were commonly known as *legends*, because chapters were to be read (*legenda*) out of them at matins and in the refectories of the religious houses. One of the best-known medieval collections is that known as the Golden Legend (q.v.). Capgrave's *Legenda Anglorum*, printed by Caxton in the 15th century, was a kind of precursor of the monumental *Acta Sanctorum* of the Bollandists (q.v.).

See the articles FOLKLORE and MYTHOLOGY. An admirable discussion of the ancient Greek heroic legends and their relation to mythology will be found in the first volume of Grote's history.

Legendre, ADRIEN MARIE, a very distinguished mathematician, was born at Toulouse in 1752. After studying at the Collège Mazarin in Paris he gained the attention of D'Alembert, and through him was appointed professor of Mathematics at the Military School. After several proofs that he had mastered the modern analysis, and especially on account of his memoir on the attraction of spheroids of revolution, Legendre was in 1783 chosen member of the Academy of Sciences. Appointed in 1787 one of the commissioners to connect Greenwich and Paris by triangulation, he was chosen member of the Royal Society of London. In his report Legendre gave the first enunciation of the 'proposition of spherical excess,' now considered an essential theorem of trigonometry, just as in 1806 he gave out the first proposal to use the 'method of least squares' in his *Nouvelles Méthodes pour la Détermination des Orbites des Comètes*. Under the empire Legendre was appointed honorary member of council for life, and member of the Commission of Public Instruction, having already been appointed to the Bureau des Longitudes and examiner at the Polytechnic. In 1827 appeared his *Traité des Fonctions Elliptiques*, a subject with which his name must remain permanently associated. He wrote several other mathematical treatises, some of the highest importance. His *Théorie des Nombres* (1830) is still a classical work and evinces much original power. His best known book is his *Éléments de Géométrie* (1794), which has been translated into many languages by Thomas Carlyle into English (1824). It is probably due to an attempt to supersede Euclid as a text book; and if so it is one of the most successful. Legendre died in Paris on 10th January 1833.

Legge, JAMES, an eminent Chinese scholar, was born at Huntly in Aberdeenshire in 1815, and was educated at King's College, Aberdeen, where he

graduated in 1835. He passed afterwards to High-bury Theological College, London, and went out to Malacca, arriving in December 1839, as a missionary to the Chinese in connection with the London Missionary Society. For some time he took charge of Dr R. Morrison's Anglo-Chinese college there; next laboured for thirty years at Hong-kong; and was appointed in 1876 to the newly-founded chair of the Chinese Language and Literature at Oxford with a Corpus Christi fellowship. His greatest works have been his editions of *Chinese Classics* and books about Confucius and Mencius (1862-93). The Confucian texts and Taoist texts form six vols. in the *Sacred Books of the East*. A Life of Confucius, the works of Mencius, and the *Shu-King* are separate publications. He published also a series of lectures on *The Religions of China* (1880), and wrote many important articles on Chinese matters, including the articles on China, Confucius, Lao-Tsze, Mencius, the Taipings, &c. in this work. He received the degree of D.D. from New York (1841), and of LL.D. from Aberdeen (1870) and Edinburgh (1884). Of the *Chinese Classics* (arranged in 7 vols.), a second ed. of vol. I. appeared in 1893. He died 29th November 1897.

Leghorn (Ital. *Livorno*) runs Naples very close for the rank of second busiest seaport of Italy (Genoa being the first); it is situated on the west coast, by rail 13 miles SW. of Pisa and 62 W. by S. of Florence. Its importance as a commercial emporium dates from the decline of Pisa; its growth was especially rapid after it fell into the hands of Florence in 1421, for the Medici princes encouraged its prosperity in every way. Cosimo I. declared it a free port, the first in the Mediterranean, and invited foreign traders to settle there, and there is still a large foreign element amongst its merchants. Early in the 19th century it was a great depot for the British trade with the Levant, but slowly lost this position after the 3d decade, because the British merchants began to send their goods to their destinations direct. Leghorn ceased to be a free port in 1868. At the present moment its foreign commerce, which is carried on chiefly with Britain (Newcastle and Cardiff), France (Marseilles), and the United States, is less in both bulk and value than its coasting trade, and since 1873 the former has been decreasing, whilst the latter has been increasing. The foreign commerce was carried on in 1885 '95 by a total of about 1000 vessels per annum, entered and cleared, of near 500,000 tons, whereas the home trade engaged 6000 vessels of 2,000,000 tons. The imports, principally spirits, sugar, dyeing materials, woven goods, corn and flour, and machinery, may have an annual value of over £2,000,000; the exports, embracing wine, silk, marble, olive-oil, boracic acid, hemp, iron, preserved fruits, leather, coral, and straw-hats ('Leghorn hats'; see STRAW), average £1,500,000 annually. The harbour (improved in 1854-63) is an enclosed basin, on which stand arsenals and shipbuilding yards. One yard employs 1200 men, and builds the great Italian ironclads. The roadstead is protected by an artificial breakwater, built in 1883, which shelters vessels against all winds except the southerly. There is a lighthouse (since 1303) between the harbour basin and this outer breakwater; and on the shore, outside the harbour, stands a lazaretto. Besides shipbuilding, the most important industry is the manufacture of coral ornaments, by some 6000 women who work in their own homes. The value of the coral ornaments exported has sunk, however, from upwards of £300,000 per annum to less than half that value, in consequence of the fall in the price of coral. The houses of Leghorn are for the most part modern and well built, lofty, and roomy; the streets are broad and clean; and there are some

fine squares adorned with statues of the grand-dukes of Tuscany. The north-western portion of the city is intersected by numerous canals; hence it is called 'New Venice.' The most interesting of the public buildings are the cathedral (17th century), its facade designed by Inigo Jones, the Jewish synagogue (ranking for size next in Europe to that of Amsterdam), the former grand-ducal palace (1695), &c. The Academy of Sciences, with a library of 40,000 volumes, and the naval academy deserve mention. The sulphur-springs and sea-bathing attract a large concourse of visitors in the season. Leghorn is defended both landwards and seawards by forts, bastions, and other fortifications, constructed for the most part in 1835-37. Smollett and Francis Homer lie buried in the cemetery of the English church. Pop. of the city (1861) 83,543; (1871) 80,948; (1881) 78,988; of the commune (1871) 97,096; (1881) 97,615; (1895) 104,500.

Legion, in the Roman military system, corresponded in force and organisation to what in modern times we should call a *corps d'armée*. It differed in constitution at different periods of Roman history. In the time of the republic a legion comprised 4500 men, thus divided: 1200 *hastati*, or inexperienced troops; 1200 *principes*, or well-trained soldiers; 1200 *velites*, or skirmishers; 600 *triarii*, or *pilani*, veterans forming a reserve; and 300 *equites*, knights who acted as cavalry, and belonged to families of rank. During this period the legions were formed only for the season; standing armies being of later growth. The *hastati*, *principes*, and *triarii* formed three separate lines, each divided into 10 *maniples* or companies, of 120 men each in the case of the two front lines, and of 60 men in the *triarii*. A *maniple* was commanded by a centurion or captain, who had a second-centurion, or lieutenant, and two sub-officers, or sergeants, under him; as non-commissioned officer there was a *decurion*, or corporal, to every squad or tent of ten men. The *principilus*, or senior centurion of the *triarii*, was the most important regimental officer, and commanded the legion in the absence of the tribunes. The 300 cavalry formed a regiment of ten *turme*, or troops of 30 horsemen, each under three *decurions*, of whom the senior had the command. The staff of the legion consisted of six tribunes, who managed the paying, quartering, provisioning, &c. of the troops, and who commanded the legion in turns for a period each of two months. This changing command, although inconvenient, lasted till the times of the civil wars, when a *legatus*, or lieutenant-general, was appointed as permanent commandant of the legion. In the time of Marius the manipular formation was abolished, the three lines were assimilated, and the legion was divided into 10 cohorts, each of 3 maniples. Soon the cohorts were raised to 600 men, making the legion 6000 infantry, besides cavalry and velites. It was ranged in 2 lines of 5 cohorts each; but Cæsar altered the formation to 3 lines, of respectively 4, 3, and 3 cohorts. During the later empire the legion became complex and unmanageable; many sorts of arms being thrown together, and balistic, catapults, and onagers added by way of artillery.

Legion of Honour, an order of merit instituted by Napoleon in 1802 as a recompense for military and civil services. It was ostensibly founded for the protection of republican principles and the laws of equality, every social grade being equally eligible. The constitution and incidents of the order have been repeatedly changed by the successive executive powers of France during the course of the 19th century. At its first institution the order embraced four classes; to these a fifth

was added in 1852. At the same time the original star was changed into a cross. At the present time there are five classes—grand crosses, of whom there are 70; grand officers, fixed at 200 members; 1000 commanders; 4000 officers; and 25,000 chevaliers or knights. Foreigners are eligible as members, but they are not counted in their respective classes. In each class three-fifths of the members must be soldiers or sailors. On the obverse of the five-rayed white enamelled cross is a female head representing the republic, surrounded by the words *Republique Française, 1870*; on the reverse are two crossed flags and the motto *Honneur et Patrie*. The cross is suspended by a wreath half of oak, half of laurel, leaves. The ribbon is watered scarlet silk. The military members receive each a pension; those of the first class get 3000 francs a year, those of the second 2000, of the third 1000, of the fourth 500, and of the fifth 250 francs. Candidates in time of peace must have served in some military or civil capacity for twenty-five years; exploits in the field or severe wounds constitute a claim in time of war. Two distributions take place in the year. The nomination of military persons takes place on parade, and of civil in the supreme courts of justice. No ignoble punishment can be inflicted on a member of the order so long as he belongs to it. To rise to a superior rank it is indispensable, at least for natives of France, to have passed through the inferior grades. In addition to the order 40,000 medals are distributed amongst the rank and file of the army. Each medal entitles its bearer to a pension of 100 francs annually. The total annual expenditure of the order amounts to seven million francs. The vast numbers holding this order, and the insignificance of many of the persons on whom it has been conferred, have detracted much from its value. At the date of the battle of Waterloo there were 48,000 members, of whom only 1400 were civilians. In the reign of Napoleon III. the order embraced 64,800, and in 1872, 69,179 persons; but a law was passed in that year that only one new member should be added for every two vacancies in the civilian ranks and one for every three or four in the military. This reduced the membership to 53,848 by 1890. The order gives free education to 400 of the daughters, sisters, and nieces of its members.

Leg-irons. See HANDCUFFS.

Legitim, or **BAIRN'S PART**, in the Scotch law, is the legal provision which a child is entitled to out of the movable or personal estate of the deceased father. The extent of the provision varies according as the wife of the father of the child survives or not. If a wife survive, and also children survive, the movable estate is divided into three equal parts. One is the widow's *Ans Relictæ* (see HUSBAND AND WIFE), another is the children's legitim, the other third is the Dead's Part (*q.v.*), which the father may bequeath by will if he pleases; but if he make no will, then it goes to the children as next of kin. If the wife is dead, then half is legitim, and the other half is dead's part. Moreover, a father, though in his lifetime he may, without any check from his children, squander his property, still is not allowed on his death bed to make gifts so as to lessen the fund which will supply legitim. The children's claim to legitim may be qualified by an antenuptial contract of marriage, which provides some other provision to the children in lieu of legitim; but, as a general rule, the children's claim cannot be defeated by anything the father can do by means of a will or what is equivalent to a will. The legitim is claimable by all the children who survive the father, but not by the

issue of those children who have predeceased. It is immaterial what the age of the child may be, and whether married or not. Children claiming legitimation must, however, give credit for any provision or advance made by the father out of his movable estate in his lifetime. All the children, though of different marriages, share in the legitimation. In England and Ireland there is no similar right to legitimation, for the father can bequeath all his property to strangers if he please; but a similar custom, now abolished, once existed in the city of London and York. By the Married Women's Property Act, 1881, the children of any woman who dies domiciled in Scotland has the same right of legitimation in regard to her movable estate as they have in the movable estate of their father.

Legitimation, in Law, is the act by which children born Bastards (q.v.) are made lawful children. By the common law of England bastardy is admissible. The maxim is 'Once a bastard, always a bastard.' By the civil and canon law, on the other hand, the subsequent marriage of parents who have children begotten and born out of lawful wedlock legitimates the children. This principle of legitimation by subsequent marriage prevails, with modifications, in the law of France, of Germany, of Holland, and of Scotland. It also prevails in most of the states of the American Union; in some it has been adopted by statute. In the reign of Henry III. the bishops of England sought to introduce the rule of the canon law into the law of England, and petitioned the lords to consent that persons born before wedlock should be legitimate so far as regarded inheritance. The earls and barons returned the famous answer of the Statute of Merton, 1235: 'We will not change the laws of England, which up to now have been used and approved.' The Legitimacy Declaration Act of 1858 provided that any native-born British subject, domiciled in England or Ireland, or claiming any estate in England or Ireland, may apply to the High Court of Justice for a decree declaring that the petitioner is the legitimate child of his parents. In the United States cases have occurred in which bastards were legitimated by special acts of the legislature.—There is another kind of legitimation, known as legitimation by royal letters. This does not confer upon bastards the full rights of lawful children, but only gives up such rights to the property of bastards as the law confers upon the crown.

Legitimists, the followers of the elder Bourbon line, as opposed to the Orleansists. See BOURBON, FRANCE.

Legnago, one of the four fortified towns of Northern Italy known as the Quadrilateral (q.v.), is situated on the Adige, 33 miles by rail S.E. from Verona. It has a considerable trade in rice, corn, and silk. Pop. 3514. The fortifications were razed by Napoleon in 1801, but rebuilt fourteen years later.

Legros, ALPHONSE, painter and etcher, was born at Dijon in 1837 of poor parents, who apprenticed him to a house-painter. He first attracted attention by pictures exhibited in the Paris Salon between 1859 and 1863. But three years later he settled in London, and becoming a naturalised Englishman was in 1876 appointed Slade Professor of Fine Arts in University College, London. The subjects he paints best are the rural scenes, and the peasants and humble priests, of France. His admirable artistic method and the austere simplicity and reserve of his style, though they secure him warm admirers amongst artists, have not made him popular. See *Dublin University Magazine* (1880) and *Art Journal* (1881).

Legume (*Legumen*), in Botany, a fruit consisting of a single carpel, two-valved, and with the seeds—one or many—attached to the ventral suture only. It is commonly called a *pod*, and occurs in most of the species of the great natural order Leguminosae (q.v.), of which the bean and pea are familiar examples.

Legumin. See CASLIN.

Leguminosae (*Fabacea* of Lindley), a great natural order of exogenous plants, containing herbaceous plants, shrubs, and trees, many of the latter of the greatest magnitude. The leaves are alternate, usually compound, and have two stipules at the base of the leaf-stalk, which often soon fall off. The inflorescence is various. The calyx is inferior, five-parted, toothed or cleft, the segments often unequal. The petals are five, or, by abortion, fewer, inserted into the base of the calyx, usually unequal, often Papilionaceous (q.v.). The stamens are few or many, distinct or variously united. The ovary is one-celled, generally of a single carpel; the style simple, the stigma simple. The fruit is a legume, which is simply a pod composed of two valves, as in the pea and the bean. The seeds are generally numerous, rarely solitary, occasionally with an aril, often curved; the cotyledons very large.—There are three sub-orders: (1) Papilionaceae, with papilionaceous flowers; (2) Casalpinea, with irregular flowers and spreading petals; (3) Mimosae, with small regular flowers.—This natural order contains almost 7000 known species, of which about 5000 belong to the sub-order Papilionaceae; it is therefore, after the great order Compositae, the most extensive of all the natural orders of flowering plants. They are spread over all parts of the world, from the equator to the poles, but their number is greatest in tropical and subtropical regions. They are applied to a great variety of purposes, and some of them are of great importance in domestic economy, the arts, medicine, &c. To this order belong the Bean, Pea, Kidney-bean, and all kinds of *pulse*: Clover, Liquorice, Broom, Laburnum, Lupine, Sema, and many other medicinal plants, Tamarind, Logwood, Indigo, and many others which afford dyes, &c.; the Acacias, Mimosas, &c. Many species are interesting on account of their beauty of form, foliage, or flowers. In the seeds of many is found a nitrogenous substance called *Legumine* (q.v.) or *Vegetable Casein*.

Le'high, a river which flows 120 miles through eastern Pennsylvania to the Delaware River. Some of its scenery is very picturesque, but the valley is more famous for its rich mines of anthracite coal.

Leibnitz (more accurately but less commonly LEIBNIZ), GOTTFRIED WILHELM, distinguished for almost universal scholarship, especially in philosophy and mathematics, was born on 1st July 1646 at Leipzig, where his father (died 1652) was professor of Moral Philosophy. He attended the Nicolai school in Leipzig, but learned much more from independent study—he taught himself to read Livy whilst still a boy of eight—and at fifteen entered the university of Leipzig to study law. He spent some time also at Jena working at mathematics. Being refused his doctor's degree at Leipzig on account of his youth in 1666, he graduated at Altdorf, the university town of Nuremberg. In the following year he gained a warm and admiring patron in Baron von Boineburg, formerly chief minister to the archbishop-elect of Mainz. At Boineburg's suggestion he presented to the elector his *Nova Methodus Docendi Discendique Juris*, containing a proposed reform of the *Corpus Juris* and of the teaching of jurisprudence; and the elector took the young scholar into his service. Amongst

other duties in which Leibnitz employed his pen was to advocate, in 1669, the claims of the count palatine of Neuburg to the crown of Poland. Three years later he was summoned to Paris to explain at greater length the views he had laid down in an essay entitled *Consilium Ægyptiacum*, which elaborated a plan for the conquest of Egypt; though the real object of the work was to divert the attention of Louis from projects in and upon the German states. This plan of Leibnitz is believed to have suggested the invasion of Egypt which Napoleon attempted in 1798. The tour was extended to London, where Leibnitz became acquainted with Oldenburg, Boyle, and Newton; in Paris he had already learned to know Arnauld, Malebranche, and Huygens. His intercourse with Huygens and Newton stimulated his interest in mechanical and mathematical questions; he invented a calculating machine and devised what was in many respects a novel method of the Calculus (q. v.; and see NEWTON, FLUXIONS). This gave rise to a controversy with Newton as to which of them first invented this valuable mathematical method. In 1676 Leibnitz quitted the service of Mainz, and entered that of Hanover. The duke appointed him custodian of the library at Hanover; and this city was henceforth Leibnitz's headquarters. But his energies found scope outside the library; he effected improvements in the drainage of the mines in the Harz and in the coinage, arranged the library at Wolfenbützel (where Lessing afterwards laboured), and in 1687 visited various cities in Germany, Austria, and Italy to gather materials for an exhaustive history of the Brunswick ducal house. The pope offered him the headship of the Vatican Library; but Leibnitz declined the offer, since the acceptance of it would have compelled him to become a Roman Catholic. The task of working up his materials into connected history employed a good deal of his time in subsequent years. Philosophy, too, absorbed a large proportion of his most serious thought. And in the discussions that were carried on with a view to the reconciliation of the Protestant and Roman Catholic churches Leibnitz took a prominent part, his principal correspondent being Bossuet. In 1686 there was published from his pen the *Systema Theologicum*, composed as a response—conciliatory—from the Protestant side to Bossuet's *Exposition de la Foi*. Subsequently, on the failure of these negotiations, Leibnitz endeavoured, but with the same want of success, to reconcile the Lutheran and the Reformed churches of Prussia. He was more successful in enlisting the interests of reigning princes in scientific societies. He induced Frederick I. of Prussia to found (in 1700) the Society of Sciences at Berlin, and was himself made first president; and he suggested the establishment of similar societies in St Petersburg, Dresden, and Vienna, which were afterwards instituted in each of those capitals. Whilst on a visit to Vienna in 1712-14 he was created a privy-councillor of the empire; he was also made a baron (Freiherr) of the empire. When George of Hanover ascended the throne of England Leibnitz, who some years before had vigorously supported his father's claims to the elector's hat, was disappointed at not being invited to accompany him. But shortly afterwards he died, on 14th November 1716, at Hanover.

The philosophy of Leibnitz holds an intermediate place between the dualism of Descartes and the monism of Spinoza (whom he visited at Amsterdam in 1676). His system is individualistic and dogmatic. He taught that the primary and essential quality of all substance is active force. Substance exists only in the form of atoms or monads, which are simple and similar in constitution, but differ qualitatively; each is a self-

contained individuality. All monads possess two intrinsic properties—perception, or the capacity to mirror the universe, and appetite or striving. The degree of perfection with which each monad reflects the universe depends upon its individual character—i.e. upon the peculiar consensus or balance of relations that exist between the active and the passive elements in its nature. And the entire series of monads, from the very highest (God) to the very lowest, were so constituted, and so arranged from the first, that, whilst each obeys the laws of its own self-determined development independently of all others, it is at every moment in complete accord and harmony with all the rest. The body of man is a complex of separate monads; his soul is a single monad, the substantial centre of his being. Yet no monad can act upon another monad; the active force of each cannot pass out of itself. But the doctrine of general 'pre-established harmony' explains how and what relations do subsist between them, and so between body and soul. He compares body and soul to two clocks which have been constructed in the beginning in such a way, and so perfectly, that both can be depended upon to keep exact time with each other without any bond of connection or any interference from without. God is the primary, supreme, perfect monad; from Him all others proceed as 'influxions' or radiations. Plants and stones are likewise monads; but in their case the perceptive capacity is more or less blurred or slumbering—an adumbration of the modern doctrine of unconscious perception. Since God is the contriver of the universal harmony that prevails amongst all created things, this world must be the best of all possible worlds (see OPTIMISM). The real cogency of Leibnitz's argument depends upon his great logical instrument, the principle of sufficient reason: there *is* a sufficient reason why this world should be the best of all possible worlds, and there is *no* sufficient reason why it should be otherwise. His theory allowed him to demonstrate that there is a substantial agreement between faith and the deliverances of reason. The Leibnitzian ethics are deduced from the property of striving inherent in every monad—the final aim being perfection, reached through individual freedom.

Leibnitz was also a pioneer in the science of comparative philology. He took steps to collect specimens of various distant languages, in Asia and elsewhere, and studied them in a scientific manner. He recognised two great divisions of speech, the Aryan, which included Arabic and Hebrew, and the Japhetic or Celto-Scythian, which coincided pretty nearly with what was subsequently called the Indo-Germanic or Aryan family of speech. Cf. Max Müller, *Science of Language*.

Leibnitz left no complete systematic account of his philosophical views. They have to be gathered from several collections of letters, essays contributed to the journals *Acta Eruditorum*, *Journal des Sçavants*, &c., and a few treatises, such as *De Principio Individui* (1663); *Essai de Théodicée sur la Bonté de Dieu, la Liberté de l'Homme, et l'Origine du Mal* (1710); *Principes de la Nature et de la Grèce* (1718); *Monadologie* (1714), and *Nouveaux Essais sur l'Entendement* (1765). In this last work he closely criticises Locke's celebrated *Essay on the Human Understanding*; and supplements the English philosopher's maxim of *Nihil est in intellectu quod non fuerit in sensu*, by adding *nisi ipse intellectus*. Editions of Leibnitz's writings have been published, though none is complete, by Dutens (6 vols. Geneva, 1768), by Fetz and Gerhardt (19 vols. 1843-50), and by O. Klopp (11 vols. 1862-84). The best *Life* is Gultzner's (2 vols. 182-46). See also biographical works by Kirchner (1877) and E. Pfeleiderer (1870), and Bodenmann on his Correspondence (1889). Feuerbach (1837), Zimmermann (1847, &c.), and K. Fischer (1867) have written on his philosophy.

Leicester, the county town of Leicestershire, a municipal, parliamentary, and county borough, is situated on the Soar, a tributary of the Trent, 22 miles S. of Nottingham, 38 ENE. of Birmingham, 20 NNE. of Rugby, and 97 NNW. of London. Traditionally founded by the British king Lear, it occupies the site of the Roman *Raba*; and pavements, urns, and other Roman relics have been found, while the 'Jewry Wall,' 20 feet high and 75 long, which got its name from the mediæval ghetto, is composed of rubble and Roman bricks. Its present name comes from the Anglo-Saxon *Leocæstre*, or 'fortress of the Leire,' as the river was called of old. The Norman castle, dismantled by Charles I. in 1645, is represented chiefly by the modernised assize hall, and by an artificial earthwork, the Mound or Castle View, on which stood the donjon-keep; the Abbey of Black Canons (1143), where Wolsey died in 1530, is an insignificant if picturesque ruin. In the Blue Boar Inn, demolished about 1829, Richard III. slept the night before Bosworth (1485); and his corpse was brought back hither for burial. A handsome memorial cross or clock tower (1868) bears the effigies of Simon de Montfort, Earl of Leicester, Sir Thomas White, Alderman Newton, and William of Wyggeston. There is a statue also of Robert Hall; and among the other edifices are the old town-hall, with good carving and stained glass of Henry VII.'s time; the new municipal buildings (1876), Queen Anne in style, with a clock-tower 134 feet high; the post-office (1887), public baths (1879), free library (1879), school of art (1876), opera-house (1877), poor-law offices (1883), corn exchange (1852), lunatic asylum (1836), the museum (1848), rich in local antiquities; the Wyggeston Hospital Schools (1513; rebuilt 1877-78); and five interesting old churches—St Nicholas', St Mary's, All Saints', St Margaret's, and St Martin's, the last with a spire 218 feet high. The New Walk is a pleasant tree-shaded promenade; the racecourse of 1806 is now a recreation ground, known as the Victoria Park, its successor being at Oadby, 3½ miles distant; the Abbey public park was opened by the Prince of Wales in 1882; and there is a third public park called the Spinney Hill Park. The abnormally rapid growth of Leicester has been due to its central position, to its transit facilities by three railway companies and by water, and to the great extension of its industries. The manufacture of plain and fancy hosiery, introduced in 1680, is equalled only by Nottingham; in that of pegged and riveted boots and shoes Leicester vies with Northampton. Iron-founding is also carried on, with manufactures of elastic webbing, sewing-cotton, lace, lamb's-wool, &c. There is coal in the neighbourhood, and a large sewage-farm. First chartered by King John, Leicester has returned two members to parliament from Edward I.'s time. It has figured prominently in the anti-vaccination contest. Pop. (1801) 17,005; (1861) 68,056; (1871) 95,084; (1881) 122,351; (1891) 174,624.

See local histories by Throsby (1777-91), T. Robinson (1793), James Thompson (1839-71), Hollings (1855), Robert Road (1881), and Mrs T. Fiddling-Johnstone (1892).

Leicester, ROBERT DUDLEY, EARL OF, born about 1532, was the fifth son of John Dudley, Duke of Northumberland, and grandson of the notorious Edmund Dudley, who was beheaded for treason by Henry VIII. His father was executed for the part which he took in the cause of Lady Jane Grey (q.v.), and he was himself sentenced to death. He was liberated in 1554; and in 1558, on the accession of Elizabeth, a great career opened before him. He was made Master of the Horse, Knight of the Garter, a Privy-councillor, High Steward of the university of Cambridge, Baron

Dudley, and finally in 1564 Earl of Leicester. For these high honours he seems to have been indebted mainly to a handsome person and a courtly manner. In 1550 he had married Amy, daughter of Sir John Robsart. She lived in the country, and early in 1560 removed to Cumnor Place, Berkshire, the house of Anthony Forster, a creature of her husband's, where, on 8th September, she was found lying dead, with her neck broken, at the foot of a staircase. It was generally believed at the time that she was murdered, and that Dudley, if not Elizabeth herself, was an accessory to the crime. This belief receives some support from certain discoveries made in the archives at Simancas, which indicate that a plot to poison her was actually entered into before her death. Elizabeth continued to favour Leicester in spite of his unpopularity in the country and of his secret marriage in 1573 to the Dowager Lady Sheffield. In 1563 she had suggested him as a husband for Mary, Queen of Scots, and in 1575 she consented to be magnificently entertained by him at his castle of Kenilworth (q.v.). In 1578 he bigamously married the widow of Walter, Earl of Essex, and when the fact was revealed to Elizabeth, she was greatly, but only temporarily, offended. In 1583 he commanded an expedition to the Low Countries, of which next year he was appointed governor—an expedition that is notable chiefly for the unsuccessful siege of Zutphen, in the course of which Sir Philip Sidney, his nephew, met with his death. In 1587 he again showed his military incapacity in the same field, and had to be recalled. Yet in 1588 he was appointed to command the forces assembled at Tilbury, to defend England against the Spanish Armada. He died suddenly on 4th September of the same year at Cornbury, in Oxfordshire, of poison, said rumour, intended for his wife. See ELIZABETH, with works there cited; and the article 'Robert Dudley' by Mr S. L. Lee in vol. xvi. of the *Dictionary of National Biography* (1888).

Leicester of Holkham, THOMAS WILLIAM COKE, EARL OF, was born on 4th May 1752, a descendant of the famous lawyer Coke. He was one of the first agriculturists of England; by his efforts for the improvement of farming north-west Norfolk was converted from a rice-growing into a wheat-growing district, its system of cultivation was entirely revolutionised for the better, and more stock and of better breeds was kept on the farms. When in 1776 he succeeded to his estates they yielded an annual rental of £2200; at his death they brought in £20,000 and more. The sheep-shearing festivals at Holkham were celebrated the country over. Coke represented Norfolk in the House of Commons during the greater part of the period from 1776 to 1833. He was a staunch Whig, and a strong supporter of Fox. In 1837 he was created Earl of Leicester of Holkham, to distinguish the title from the Earldom of Leicester, already held by the Townshend family. Coke refused every other title except that of Earl of Leicester, because that title had been borne by his great-uncle, but on his death in 1759 had become extinct. He died at Longford Hall, Derbyshire, 30th June 1842.

Leicestershire, a midland county of England, surrounded by Nottingham, Lincoln, Rutland, Northampton, Warwick, and Derby shires. It has a maximum length and breadth of 44 miles by 40, and contains 863 sq. m., or 514,164 acres. Pop. (1801) 131,081; (1841) 215,867; (1881) 321,258; (1891) 373,984. Its surface is mainly undulating tableland, the highest ground being at Charnwood Forest in the north-west, where Bardou Hill rises to a height of 853 feet above sea-level. The Soar, itself an affluent of the Trent, which for a

short distance borders the county on the north, is, with its tributary the Wreak, the principal river. The soil, varying in fertility, is generally loamy; in the north-west are valuable coal-mines, also granite, slate, and limestone quarries, but the greater part of the county being under pasture, the quantity of corn grown is comparatively small. According to the agricultural returns for 1889 the area under corn crops was only 73,582 acres, and under green crops 20,935 acres, whilst 341,905 acres were laid down as permanent pasture or grass. Hence the principal objects of agriculture practised in the county are grazing and sheep and cattle breeding, Leicestershire being especially noted for its breed of the former. Of manufactures the principal are those of hosiery and boots and shoes; basket-making is carried on at Castle Donnington; and Stilton cheeses are for the most part made in this county. Leicestershire comprises six hundreds, the parliamentary and municipal borough of Leicester, and 332 parishes, almost entirely in the diocese of Peterborough, and, for judicial purposes, in the Midland Circuit. Leicester is the assize town, and other towns are Ashby-de-la-Zouch, Hinckley, Loughborough, Lutterworth, Market Harborough, and Melton Mowbray, the last two being great hunting centres. Six members are returned to parliament, and the county council consists of fifty-one members. In historical annals the principal event associated with the county is the battle of Bosworth Field (1485), in which Richard III. lost his life. Amongst persons of note identified with Leicestershire may be mentioned Wyclif, Cardinal Wolsey, Lady Jane Grey, Mary Queen of Scots, Beaumont the dramatist, George Villiers, Duke of Buckingham, Cleveland the poet, George Fox, Simpson the mathematician, Dr Johnson, Lord Macaulay, Hobart Pasha, Colonel Burnaby, and last, but not least, Daniel Lambert. See the histories of the county by Burton (1622; 2d ed. 1777), Nichols (4 vols. 1795-1815), and Curtis (1831).

Leichhardt, FRIEDRICH WILHELM LUDWIG, explorer in Australia, was born at Treborsch, south-east of Berlin, on 23d October 1813, and studied philology at Göttingen and natural science at Berlin. In 1841 he proceeded to Australia. There he conducted an expedition (1843-48) from Moreton Bay, in Queensland, north-westwards to the Gulf of Carpentaria, and then, skirting its south and west shores, finally reached Port Essington. In the end of 1846 he made an unsuccessful attempt to cross the base of Cape York Peninsula. In November 1847 he again started from Moreton Bay with the intention of crossing the entire continent from east to west, but he was lost in the interior. Nothing authentic has been heard of him since April 3, 1848. The *Journal* of his first journey was published in London in 1847, and his *Letters* in German in 1881.

Leigh, a town of Lancashire, 21 miles NE. of Liverpool and 16 W. of Manchester. Silks and cotton goods are extensively manufactured; iron-foundries, breweries, malt kilns, and glass-works count amongst the principal industrial establishments. In the vicinity are productive coal-mines. Pop. (1861) 10,621; (1881) 21,734; (1891) 28,702. See Worsley's *History of Leigh* (1870).

Leighton, FREDERICK, LORD, P.R.A., was born at Scarborough 3d December 1830. His father was a doctor, but he early recognised his son's bias towards painting, and gave him what he deemed the best training for his profession. Frederick's early years were spent in a series of grand tours. He visited Rome, Florence, Frankfurt, Berlin, Paris, and Brussels, and everywhere he received instruction from the most distinguished

masters. At fourteen he was already a promising student at the Accademia di Belle Arti at Florence. At Frankfurt he came under the influence of Steinfel, a rigid Teuton, the friend and disciple of Overbeck; and there remained a certain coldness in his colour which proved that he never quite lived down the results of Steinfel's tuition. He made his first appearance at the Royal Academy in 1855 with his famous picture 'Cinabine's Madonna' carried in Procession through the Streets of Florence.' This work was an immediate success and was purchased by the Queen. Of his later works may be mentioned 'The Triumph of Music' (1856), 'Paolo and Francesca' (1861), 'The Odalisque' (1862), 'Atiadne' (1868), 'Hercules wrestling with Death' (1871), 'The Harvest Moon' (1872), 'The Daphnephoria' (1876), 'Wedded' (1882), 'Cymon and Iphigenia' (1884), 'Andromache' (1888), 'The Bath of Psyche' (1890). He also won considerable distinction as a sculptor, and in 1877 his 'Athlete struggling with a Python' was purchased out of the funds of the Chantrey Bequest. In 1864 he was elected Associate of the Royal Academy. Five years later he took his place among the forty. On the death of Sir Francis Grant in 1878 he was elected President and was knighted. He was created a baronet in 1886. He received a grand medal of honour for sculpture at the Paris Exhibition of 1889, and the universities of Cambridge, Oxford, and Edinburgh conferred upon him their honorary degrees. He was created Lord Leighton of Stretton on 1st January 1896, died, unmarried, on the 25th of the same month, and was buried in St Paul's. Lord Leighton was a scholar and a man of the world as well as a painter, and discharged the duties of his onerous position with marvellous tact and success. Under his presidency the Academy enjoyed a material prosperity and social influence which it attained under no one of his predecessors. As an artist he was always inspired by the loftiest ideals, and assiduously cultivated the 'grand style.' Neither realism nor archaeology ever availed to turn him aside from the straight path; but it may be objected that his temperament was rather that of the scholar than of the artist. Of his Daphnephoria (sold in 1893 for £3700) Holman Hunt said, 'It is the very noblest painting produced in modern, if it does not excel all of ancient, times.' See Mrs Andrew Lang in the *Art Annual*, 1885, and a monograph by Ernest Rhys (1909).

Leighton, ROBERT, perhaps the rarest flower that has grown out of Scotch theology, was born in 1611, but where is as yet quite uncertain. He was the second son of Dr Alexander Leighton (1568-c. 1649), Presbyterian minister in London and Utrecht, the author of *An Appeal to the Parliament: or Simon's Plea against the Prelate* (1628), which earned him from the tender mercies of Laud the cruel punishment of scourging, the pillory, branding and mutilation, heavy fine, and close imprisonment. At sixteen the boy went to the university of Edinburgh, where he graduated M.A. in 1631. The only record of his college days is a sarcastic and obvious epigram on Aikenhead, the provost of Edinburgh. He next spent some years in France, and widened his spiritual sympathies by living some time with Roman Catholic relatives at Douay. He was ordained Presbyterian minister of Newbattle in 1640, signed the Covenant along with his parishioners two years later, and, in spite of Burnet's account of his lack of sympathy with his brethren, appears to have taken his part in all the Presbyterian policy of the time, and even to have represented the Synod of Lothian in a mission to London. The famous story of his being questioned 'whether he preached to the times' and of his retort that surely they might 'permit a poor brother to preach Jesus Christ and eternity' is

unauthenticated. At this period he was a frequent visitor to London, and after 1646 he went thither once a year. About the close of 1652 he applied for leave to resign his charge, on the plea of inability to perform its duties from ill health and weakness of voice, and early next year he was allowed to do so on being appointed Principal of the university of Edinburgh.

Here he remained nine years, and Burnet testifies to his remarkable influence over the students. Elsewhere he tells us of the wonderful effect of his preaching, which yet displeased Presbyterian zealots from its haranguing method, without heads. Leighton's *Prælectiones Theologicae* are extant to show the kind of Latin orations which he delivered weekly. Most of the *Sermons* and the *Commentary on the First Epistle of Peter* were the work of the Newbattle period. The Restoration placed on the throne an absolute king with a rooted determination to force Episcopacy on Scotland. Leighton after much reluctance was forced by the king himself to become one of the bishops of the new ecclesiastical regime, but with characteristic modesty chose for himself Dunblane, the poorest of the new dioceses, although the elevation was to him 'a mortification greater than a cell and hair-cloth.' The worldly-minded Sharp at first had his scruples about receiving new ordination; to the saintly Leighton, indifferent to the mere externals of religion, this was a detail of no great moment. On the northward journey he discovered the true motives of Sharp and his brother bishops, and left them at Morpeth to avoid their hateful triumphal entry into Edinburgh. For the next ten years the beautiful little town of Dunblane was his home, and here he laboured with a sinking heart to build up the shattered walls of the church, although he soon lost all hope of success, while his work 'seemed to him a fighting against God.' It was characteristic of the man that he never would permit himself to be addressed as 'my lord,' and that he only appeared in parliament when church matters were in dispute. His conception of Episcopacy was similar to that suggested by Archbishop Ussher, and his aim was to preserve what was best in the two systems as a basis for comprehensive union, 'reconciling the devout on different sides.' But nowhere among his unworthy associates did he find any 'such appearance of seriousness or piety as became the new-modelling of a church,' and he only succeeded in being misunderstood by both sides, his moderation being misread by the fiercer Presbyterians as 'pretended holiness, humility, and crucifixion to the world,' assumed as 'a cloak under which to creep toward promotion'—'a mere betrayal of religion with a kiss.' The severity of his life, his unworldliness, and even his celibacy, were thought to savour of Romanism, and already his recommendation of his favourite book, *The Imitation*, to the Edinburgh students, had given offence to rigid Presbyterian-like Dickson, who refused it because 'self and merits run through it.' Row characterises him as 'carrying like a pawky prelate,' and says that his condescensions made the Dunblane clergy think 'he was but *stoking* cream in their mouths at first.' The continued persecutions of the government, bent on playing out 'a forlorn after-game,' drove him to London in 1665 to resign his see. He told the king he 'could not concur in the planting the Christian religion itself in such a manner, much less a form of government.' Charles apparently listened with respect, and the good bishop was persuaded to return. Again in 1669 he went to London to advocate his scheme of Accommodation, and after his return voted in favour of the unjustifiable Assentory Act—a weak piece of compliance

which he repented all his life. Immediately after he assumed the duties of commendator of the archdiocese of Glasgow, while still continuing for some time Bishop of Dunblane. Next followed his fruitless conferences at Edinburgh in 1670 and 1671 with leading Presbyterians on behalf of Accommodation, and his sending through the western counties itinerant advocates of the cause. In despair of success he begged for permission to retire, and at length about the close of 1674 was permitted to lay down his archbishopric. His letter to Lauderdale (December 17, 1674) describes his sickness and sense of his own unworthiness, and his desire to spend the remainder of his life in quiet retirement, as well as 'pity to see a poor church doing its utmost to destroy both itself and religion in furious zeal and endless debates about the empty name and shadow of a difference in government, and in the meanwhile not having of solemn and orderly public worship so much as a shadow.' His last ten years he spent in calm preparation for his end, in the house of his widowed sister, Mrs Lightmaker, at Broadhurst Manor in Sussex, frequently preaching in the church of Horsted Keynes, in the south transept of which he lies. His death, which was the result of an attack of pleurisy, came suddenly, 25th June 1684, in an inn—as he often said he wished it should—in Warwick Lane, London, whither he had been summoned by Burnet to an interview with Lord Perth, just appointed Lord Chancellor of Scotland.

No man ever lived more intensely absorbed in the love of God than Leighton; no saint was ever filled with a greater measure of the spirit of Christ. It was characteristic of him that he never thought his writings of any value, that he printed nothing himself, and that he left orders for his MSS. to be destroyed; yet no religious books reveal a deeper spirituality, a more heavenly exaltation and devotion. And no less wonderful is their sweetness and beauty, wedded to sincerity and intellectual strength, as well as their broad catholicity of spirit—the direct outcome of a large mind moulded in Christian charity. He saw the good that underlay all ecclesiastical systems, and yet recognised how profitless all might become if allowed to interpose between the human soul and God. Love of peace was with him a passion, though unhappily he fell on evil days and unhappy methods of conciliation. The best tribute to his memory is from the pen of Burnet, who says at the conclusion of his *Pastoral Care*, 'in a free and frequent conversation with him for above two and twenty years, I never knew him say an idle word that had not a direct tendency to edification; and I never once saw him in any other temper but that which I wished to be in in the last moments of my life.' And again in the *History of His Own Time* he says: 'I bear still the greatest veneration for the memory of that man that I do for any person; and reckon my early knowledge of him, which happened the year after this [Leighton's promotion to a bishopric], and my long and intimate conversation with him, that continued to his death, for twenty-three years, among the greatest blessings of my life; and for which I know I must give account to God, in the great day, in a most particular manner.' Of great modern Englishmen none has esteemed Leighton more highly than Coleridge, whose *Aids to Reflection* indeed is based on aphorisms culled from his writings.

Leighton left his library to Dunblane, which has another memorial of its great bishop in the 'Bishop's Walk' along the banks of the Allan Water. In the *Bibliotheca Leightoniana* there were originally more than 1500 volumes, and upwards of 1200 still remain, more than 200 of which have interesting marginalia. His first editor was his friend Dr Fall, who printed most of the works from 1692

to 1708. The chief later editions are those of Doddridge (1748), Jerment (1805-8), Pearson (1825), and Aikman (1831). The last three editions have lives of the author, of which Pearson's is full and good. The best and most complete edition is that of the Rev. William West, although the method of editing is not entirely to be commended, and the anti-Presbyterian prejudice ill befits the subject. The work was the labour of a quarter of a century, and vols. ii.-vi. were issued 1869-70; vol. vii., 'Remains,' in 1875. Vol. i., to include the Life and Letters, is not yet published. There is an admirable volume of *Selections from the Writings*, with a brief Memoir (1883), by the Rev. Dr Blair of Dunblane. See also the last scholar's 'Bibliography of Archbishop Leighton' in the *British and Foreign Evangelical Review* for July 1883.

Leighton-Buzzard, a market town of Bedfordshire, on the Ouse, 41 miles by rail N.W. of London. Its fine cruciform church, mainly Early English, has a spire of 193 feet, and was restored in 1886; in the market-place is a pentagonal cross; the corn exchange was built in 1862. Straw-plait is the staple industry. The suffix *Buzzard* is a corruption of Beaudesert or Bosard, a great family here in the 14th century. Pop. (1851) 4465; (1881) 5991.

Leiningen, a mediatised princely House of Germany, dating back to 1096. In 1779 the head of one of the branches into which it had become divided, the Count of Leiningen-Dachsburg-Hardenburg, was raised to the rank of a prince of the empire; but the peace of Lunéville deprived him of his ancient possessions, about 252 square miles in extent, on the left bank of the Rhine. Though no longer an independent prince, the head of the House retains his rank and wealth, and owns extensive possessions in Bavaria and Hesse. The mother of Queen Victoria had for her first husband the Prince of Leiningen.

Leinster, one of the four provinces of Ireland, occupies the south-east portion of the country. See IRELAND.

Leipa, a town of Bohemia, 40 miles N. by E. of Prague. It has some manufactures of woollens, cotton, glass, and steel. Pop. 9090.

Leipzig (Fr. *Leipsic*), the third commercial city of Germany, is situated in a large and fertile plain in the kingdom of Saxony, 80 miles by rail W.N.W. of Dresden, and 101 S.S.W. of Berlin, within 6½ miles of the Prussian border, and 3 miles above the junction of the three small streams, Elster, Pleisse, and Parthe. The inner or ancient town, the centre of the business activity, with narrow and crooked streets and quaint houses, is separated by a broad, tree-shaded promenade (laid out since 1781 on the site of the old walls) from the much more extensive modern suburbs, bounded in their turn by a girdle of busy manufacturing 'villages.' Of these last, Renditz, Entritzsch, Gohlis, and others were incorporated with the city in 1889 and 1890. The pop. within the official city limits was in 1800, 32,146; in 1860, 85,394; in 1880, 149,981; and in 1885, 170,312, including a garrison of 3373; in 1895, including all the villages incorporated in the preceding years, the population was 399,963. Many handsome edifices have been erected, numerous fine streets laid out and built, and great civic improvements effected at Leipzig in the last quarter of the 19th century; but few of the public buildings are specially remarkable. The two principal city churches, the Thomaskirche and the Nicolai kirche, date respectively from 1496 and 1525; the quaint old Rathhaus, or town-hall, from 1556. The old Pleissenburg (built in 1213, rebuilt 1551) was repeatedly besieged (in the Thirty Years' War) and taken; all but the tower was demolished since 1895. Amongst the modern buildings are the Municipal Theatre (1868), one of the largest and handsomest in Germany; the Museum (1856-58; enlarged in

1883-86); the new Exchange (1884-86); the Observatory (1861); the Booksellers' Exchange (1888), with an interesting museum; St Peter's Church (1885), a fine specimen of modern German Gothic; and the magnificent Imperial Law-courts, opened in 1895. The noble New Gewandhaus has since 1884 superseded the old Gewandhaus (so called because originally a drapers' hall), in which, since 1781, some of the best concerts in Europe were given. Leipzig contains numerous squares and open spaces, affording ample room for the stalls and booths of the retail dealers at the fairs. The largest is the Augustus-Platz; the quaintest the Market-place, in which a large war monument for 1870-71 was unveiled in 1888. The Rosenthal and the Johanna-Park are fine parks on the outskirts; while farther out are fine oak and beech woods.

Leipzig resembles Edinburgh in being an important legal, educational, and book-publishing centre, though in its other commercial interests it far outdistances the Scottish capital. It has been the seat of the supreme court of the German empire since 1879. The foundation-stone of a new building for this tribunal was laid here in 1888. The university, founded in 1408 by a secession from Prague, has 182 professors and lecturers, and more students (averaging over 3000) than any other German university except Vienna, Berlin, and Munich. The Augusteum, or main building, is in the old town; but it is supplemented by spacious medical and physical laboratories and other 'institutes' (forty-eight in number) in other parts of the town, including a new library-building containing 350,000 vols. and 4000 MSS. The City Library has 100,000 vols. and 1500 MSS. Among the numerous other educational establishments are two gymnasias, a justly famous School of Commerce, a conservatory of music (400 pupils), reckoned amongst the first in Europe, and many literary, artistic, and scientific institutions. The hospital system of Leipzig is one of the best developed in Europe, and has largely benefited the medical faculty of the university. As a seat of trade Leipzig is inferior only to Hamburg and Berlin among the towns of Germany. The chief articles of commerce are furs and skins, cloth, leather, and books. The famous Leipzig fairs are held at Easter, Michaelmas, and the New Year, and last from three to five weeks. Their origin is traced as far back as 1180; their importance dates from about 1500, and they reached their greatest prosperity at the end of the 17th and the end of the 18th centuries. The accession of Saxony in 1833 to the German Customs Union (Zollverein) gave another lullip to the business of these fairs; but since 1865 the growth of railways and telegraphs, and the greater numbers of commercial travellers have gradually reduced their importance, though they are still attended by about 30,000 strangers, including Jews, Turks, Greeks, Armenians, Persians, and even (of late) Chinese. Transactions to the extent of over £10,000,000 sterling are said to take place at the Easter fair. Leipzig ranks next to London and Paris as a seat of the bookselling and publishing trade. Nearly 500 houses are engaged in the book-trade, and there are also about eighty printing establishments; while type-founding has here its chief centre in Germany. The German booksellers have established a common exchange and clearing-house at Leipzig; and at the annual settlements of accounts at the Easter or Jubilate fair six thousand principals are said to be here represented by their commissioners. The wool-market, in June, is still much frequented, though the amount of wool offered for sale in 1888 (about 218,000 lbs.) was less than half that offered in 1878.

Among the chief manufactures (carried on mainly in the 'villages') are pianofortes, paper, chemicals, oils, scientific instruments, spirits, beer, tobacco, and some textiles. Iron-founding is also carried on. The wax-cloth industry is declining.

Leipzig, formerly Libzk or Lipzk (from the Slavic *Lip* or *Lipa*, a 'lime-tree'), originally a Wendish settlement, is first mentioned as a town in 1015. In the latter part of the 12th century it had from 5000 to 6000 inhabitants, and it rapidly grew in importance and prosperity under the fostering care of the margraves of Meissen, who granted it numerous commercial privileges. Leipzig suffered greatly in the Thirty Years' War, in which it was five times besieged and taken, and again in the Seven Years' War; and although the commercial changes connected with the French Revolution at first affected it very favourably, yet it suffered not a little amidst the terrible struggles of the years 1812 and 1813, when it was alternately in possession of the French and of the allies. In 1866 it was occupied for some months by Prussian troops. In recent years Leipzig has been noted as the headquarters of the Socialistic party in Germany. The famous Leipzig Conference between Luther, Eck, and Carlstadt, which took place in the Pleissenburg in 1519, and the Leipzig Interim (see INTERIM) of 1548 are important in the history of the Reformation. Leipzig was the birthplace of Leibnitz and of Wagner; J. S. Bach was director of music in the two chief churches, and 'cantor' in the Thomasschule from 1724 till 1750; and Mendelssohn was director of the Gewandhaus Concerts from 1835 till 1841. In literary history Leipzig is famous as the seat of the Saxon or Leipzig school of criticism, headed by Gottschel (q.v.). One of the scenes in Goethe's *Faust* is placed in Auerbach's Keller, in Leipzig, still shown, with old frescoes illustrating the legend used by the poet.

The immediate neighbourhood of Leipzig has been the scene of two battles of great importance in the history of Germany and of Europe—the battle of Leipzig, or of Breitenfeld (q.v.), on September 7, 1631; and the great battle of Leipzig—called the *Battle of Nations*—from the 16th to the 18th of October 1813. The latter was one of the most bloody and decisive of those which effected the deliverance of Europe from French domination. The troops under Napoleon in this battle amounted to about 180,000 men, and those of the allies, commanded by Prince Schwarzenberg, Marshal Blücher, and Bernadotte, Crown prince of Sweden, to almost 300,000. The loss of the French was reckoned at about 30,000 killed and wounded, and 38,000 prisoners; that of the allies at about 52,000. The victory of the allies was complete, and the French had to evacuate Leipzig.

See works on Leipzig by Grosse (1837-42), Sparfeld (1851), Kneschke (1870), Wurtke (1873), Hasse (1878), Hirschfeld (1887), Moser, Bönndorf, &c.

Leith, the fifth largest town in Scotland, an important seaport, and a municipal and parliamentary burgh, stands on the southern shore of the Firth of Forth, at the mouth of the Water of Leith, 2 miles N. of Edinburgh (q.v.), with which it is now connected by a continuous line of street. It is even less attractive than most seaport towns; still, great improvements have been effected since 1877, and some of the public buildings are not bad. Among them are the court-house or town hall (1827), custom-house (1812), exchange, corn exchange (1862), Trinity House (1816), hospital (1850), Sailors' Home (1883-84), and St James's Episcopal Church (1862-69), by Sir G. G. Scott, with a spire 180 feet high. Leith Fort (1779) is now the artillery headquarters in Scotland. The harbour-works have cost upwards of a

million sterling. They comprise five docks, constructed between 1801 and 1881, with an area of 43 acres, besides a sixth (1892-1901), with an area of 60 acres; seven graving-docks; and two piers, 1177 and 1041 yards long. The foreign, colonial, and coasting trade of the port is great and increasing. In 1896, 4282 ships with an aggregate tonnage of 1,556,917 tons entered, and 4038 ships of 1,544,050 tons cleared. The imports (corn, chemicals, sugar, woollen and linen yarn, timber, fruits, &c.) have an annual value of more than £8,000,000; the exports (coal, iron, cotton goods, &c.) of about £3,000,000. There is regular steamboat communication with London, the north of Scotland, several continental ports, and New York. Shipbuilding has of recent years become a large and important industry; and extensive employment is also afforded by large flour-mills, sugar-refineries, distilleries, breweries, engineering-works, sawmills, rope-works, chemical works, &c. Leith was constituted a parliamentary burgh in 1833, and with Portobello and Musselburgh returns one member. Its nine months' siege by the Protestants (1559-60), the surprise of its citadel by the Jacobites (1715), and royal visits, innumerable are the chief events in its history. Home, the author of *Douglas*, was a native; John Logan was a minister; and Robert Nicoll is buried here. Pop. (1841) 26,026; (1881) 59,485; (1891) 68,707. See works by A. Campbell (1827), D. H. Robertson (1851), J. Martine (1888), and J. C. Irons (1898); see also EDINBURGH.

Leitha, an Austrian stream rising in Lower Austria, and flowing NE. to join the Danube nearly along the frontier of Lower Austria and Hungary. Since the reorganisation of the empire in 1867, it has become usual to speak of Hungary and the lands belonging to the Hungarian crown as *Trans-leithan*, and the rest of the empire as *Cis-leithan*—thus giving the stream a factitious importance.

Leitmeritz, an old town, partly walled, of Bohemia, at the head of steamboat navigation on the Elbe, here crossed by a bridge 1805 feet wide, 34 miles W. by N. of Prague. Here are a cathedral (1671) and a bishop's palace; and in the town-house (1535) valuable archives are preserved. Brewing is the staple industry. Fruit, wine, and hops are extensively grown. Pop. 10,854.

Leitmotiv. See MOTIF, WAGNER.

Leitomischl, an old town of Bohemia, 85 miles ESE. of Prague, with a fine castle, a Piarist college, and manufactures of linens, woollens, jute, &c. Pop. 5258.

Leitrim, a county in the north-east of the province of Connaught, in Ireland. Its greatest length, north east to south-west, 51 miles; greatest width, 21 miles. Area, 376,242 acres, or 588 sq. m., of which 282,400 are arable, 11 per cent. barren, and 7 per cent. bog. The county touches the ocean on the north, and is divided into two parts by Lough Allen (q.v.), from which the Shannon forms the south-west boundary of the county. The southern division contains numerous small lakes. The northern division is intersected by several ridges. To the north of Lough Allen the soil, except at rare intervals, is unfavourable for agriculture, and the climate damp and ungenial. Leitrim is more a grazing than a tillage district, 53 per cent. of its area being grass-land. Potatoes and oats are the only crops of consequence. Coal is found in the Lough Allen basin; and iron and lead ores are abundant, although mining operations are very sparingly carried on. Linens and coarse woollens are manufactured for domestic use. The county town is Carriek-on-Shannon. Leitrim returns two members. Pop.

(1841) 155,297; (1861) 104,744; (1881) 90,372; (1891) 78,618. Leitrim was reduced by the English in the reign of Elizabeth, but revolted in 1588, submitting once more in 1603. The confiscations which followed the Civil War practically extinguished the native proprietary and the family of O'Rourke to whom it had once belonged.

Lekin (*Li-kin*), the transit-dues of China (q.v.).

Leland, CHARLES GODFREY, an American author, was born in Philadelphia, 15th August 1824, graduated at Princeton in 1846, and afterwards studied at Heidelberg, Munich, and Paris. He was admitted to the Philadelphia bar in 1851, but turned from law to journalism. From 1869 he resided chiefly in England, and investigated the language and customs of the Gypsies, a subject on which between 1873 and 1890 he published four valuable works. Leland is most widely known, however, for his dialect poems in 'Pennsylvania Dutch,' the famous *Hans Breitmann Ballads* (1871). Other works are *The Poetry and Mystery of Dreams* (1855), *Meister Karl's Sketch-book* (1855), *Legends of Birds* (1864), *Fu-Siang* (1875), *Algonquin Legends* (1884), *Etruscan Remains and Popular Tradition* (1892), *Hans Breitmann in Tyrol* (1895), besides a translation of Heine. See his autobiographical *Memoirs* (1893).

Leland, JOHN, born in London about 1506, was educated at St Paul's, then at Christ's, Cambridge, and All Souls', Oxford. He became chaplain to Henry VIII., who in 1533 commissioned him as 'king's antiquary,' with power to search for records of antiquity in the cathedrals, colleges, abbeys, and priories of England. The next six years he devoted to his tour with unresting diligence, and collected 'a whole world of things very memorable,' to the arrangement of which he gave the remainder of his life. His church preferences were the rectories of Pöfeling, in the marches of Calais, and Haseley in Oxfordshire, a canonry of King's College (now Christ Church), Oxford, and a prebend of Salisbury. His last five years were darkened by insanity, from which he found relief in death, April 18, 1552. He had laboured in vain with gigantic industry to arrange and digest his vast collection of materials, into which harrowed his successors, Stow, Camden, William Burton, and Dugdale.

Most of his papers are now in the Bodleian and British Museum. Besides his *Comментарii de Scripioribus Britannicis* (ed. by Anthony Hall, 2 vols. 1709), his chief remaining works are *The Itinerary* (ed. by Thomas Hearne, 9 vols. 1710-12) and *De Rebus Britannicis Collectanea* (ed. by Hearne, 6 vols. 1715). For his life, see the *Life of Leland, Hearne, and Wood*, edited by W. Huddesford (2 vols. 1772).

Leland, JOHN, an eminent 18th-century English apologist for Christianity, was born at Wigan, in Lancashire, in 1691, and educated at Dublin, where he was a Presbyterian minister from 1716 till his death in 1766. His first publication was *A Defence of Christianity* (1733), in answer to Tindal's deistical work, *Christianity as Old as the Creation*. This was followed by *The Divine Authority of the Old and New Testaments*, in answer to Morgan's *Moral Philosopher*. His most important work is *A View of the Principal Deistical Writers that have appeared in England* (1754-56). Leland was, in Leslie Stephen's phrase, the 'most worthy, painstaking, and commonplace of divines,' and many more than the few that read it still regard his work as a satisfactory demolition of deism. To his *Discourses on Various Subjects* (1 vols. 1768-89) was prefixed a Life.

Lely, SIR PETER, painter, was the son of Captain Van der Faes, nicknamed Du Lys, or Lely, from having been born in a house the front of which was

decorated with a fleur-de-lis. The future painter was born at Soest, in Westphalia, in 1618. He settled in London in 1641 and took to portrait-painting, having hitherto essayed landscapes and historical subjects. He was employed successively by Charles I., Cromwell, and Charles II., the last of whom nominated him court-painter and conferred on him the honour of knighthood. From the death of Vandyck he was the first painter of the day in England down to the arrival of Kneller. Lely, 'a mighty proud man, and full of state' (Pepys), had great skill in execution, especially in painting female portraits, though he failed to master the secrets of individuality. His best-known pieces, apart from portraits of his royal patrons, are the Beauties of the court of Charles II. at Hampton Court. He died in London in 1680.

Leman, LAKE. See GENEVA (LAKE OF).

Le Mans. See MANS.

Lemberg (formerly *Lowenberg*; Polish name 'Lwow'), the capital of the Austrian kingdom of Galicia and Lodomeria, is situated on a small tributary of the Bug, in a narrow basin among hills, 212 miles E. of Cracow. It is defended by a citadel, around which the modern town has grown up. Pop. (1869) 87,109; (1890) 128,419, or whom about 40,000 are Jews, whilst nearly 100,000 speak Polish. Lemberg is the seat of a Roman Catholic, a Greek United, and an Armenian archbishop, and has nearly thirty churches and several monasteries; in the 17th century and earlier it was called the 'town of the monks.' Several of the churches are fine buildings, as the Dominican, which contains a greatly venerated image of the Virgin; the Greek cathedral, built in the Italian style in 1740-79; the Gothic Roman Catholic cathedral (1350-1460); and the Armenian cathedral, dating from the 14th century. The university, founded in 1784 and reorganised in 1817, has more than 900 students. Its library contains 86,000 volumes and 470 MSS. Here also is the seat of the national institute founded (1817) by Ossolin-ski, with a library of 81,000 volumes and 3000 MSS., chiefly of Polish literature, and large collections of medals, coins, antiquities, paintings, engravings, &c. There is a considerable trade in flax, hemp, cloth, leather, and agricultural products. The manufactures embrace machinery, earthenware, oil, beer, &c. Founded in 1259, Lemberg was an important city of Poland from 1340. It has been several times besieged, on the last occasion in 1848. It fell to Austria at the first partition of Poland.

Lemming (*Myodes*), a genus of rodents, nearly allied to voles, but with much shorter ears and tail, larger and stronger claws, and a heavier body. The most noted species is *M. lemmings*, an animal about the size of a rat, with variegated black and tawny fur, an inhabitant of the northern Scandinavian mountains, where it ordinarily feeds on reindeer-moss and other lichens, grass, catkins of birch, &c. Breeding several times in the course of a year, and producing four or five at a birth, it multiplies so much that, periodically, vast troops migrate from their native mountains. They proceed persistently in a straight line according to some always westwards, swimming rivers, crossing mountains, entering towns, devouring, breeding, and dying as they hurry on. They move chiefly in the night or early morning. Bears, wolves, foxes, lynxes, hawks, and owls follow and prey upon them, and most of the survivors finally drown themselves in the sea, thus pitifully readjusting the balance between population and subsistence. For ingenious theories and curious details about the migration, see Romanes, *Mental*

Evolution in Animals (1883). In times of prevalent superstition lemmings were often exorcised by the priests, and the peasantry of Norway supposed them to fall from the clouds. During



Lemming (*Myodes lemmings*).

the Ice Age the lemming extended as far south as the Alps, but it now is distinctly arctic. An allied species (*M. obensis*) occurs in Siberia and North America. Another quite distinct 'lemming' (*Cuniculus torquatus*), inhabiting the arctic regions of both hemispheres, turns white in winter.

Lemnos, a Turkish island in the northern part of the Aegean Sea, is situated 40 miles SE. of Mount Athos and about the same distance SW. of the Dardanelles. It is nearly split in two by a large bay on the south coast and another on the north coast. The interior consists of an undulating plateau. None of the hills exceed 1400 feet in height. Area, 180 sq. m.; pop. about 39,000, all Greeks, except 5000 Turks. The principal products are corn, wine, and tobacco. In antiquity and all through the middle ages the most notable product of the island was the 'Lemnian earth' or 'sealed earth,' which was in general request as an antidote against snake-bites, also as a remedy in cases of plague, dysentery, &c. It was extracted only on one day in the year, August 6, with an accompaniment of religious ceremonies, from a spot near the ruined site of the ancient city Hephæstia, in the north-east of the island. It has now gone out of repute, and very little is extracted every year. It consisted of siliceous to the extent of two parts in three, with some alumina, oxide of iron, water, and natron. In ancient times the island is stated to have possessed an active volcano; at the present date there exist no traces of volcanic action. Lesbos was regarded by the Greeks as sacred to Hephæstus. It was conquered by the Persians in the reign of Darius Hystaspes; but Miltiades wrested it from them for the Athenians. In 1657 it passed into the hands of the Turks, from the Venetians. The chief town is Kastro (the ancient Myrina), a fortified place on the west coast, with 3000 inhabitants. Lemnos is a place of banishment for Turkish political offenders. See *Tozer's Islands of the Aegean* (1890).

Le Moine, JAMES MACPHERSON, Canadian author, was born in Quebec, 24th January 1825, and practised as a successful barrister there for some years, but quitted the active work of his profession in 1858, on being appointed superintendent of Inland Revenue at Quebec. He writes with equal facility in English or French, and is the most prolific author that Canada has produced. He has made special studies of ornithology, archaeology, and other branches of science; and his works

—over thirty in number—include some valuable sketches of Canadian history.

Lemoine, JOHN ÉMILE, French journalist, was born in London on 17th October 1815 of French parents, and joined the staff of the *Journal des Débats* as English correspondent in 1840. Subsequently he was appointed editor of that newspaper, and guided it skilfully and successfully through all the vicissitudes of political strife. In 1876 he was elected a member of the Academy, and in 1888 a life senator. He died 14th December 1892. His *Études Critiques* (1852) and *Nouvelles Études* (1862) contain specimens of his best style.

Lemon, the fruit of a small tree (*Citrus Limonium*) belonging to the same natural order as the Orange (*Aurantaceæ*). The general character of the leaves and flowers and fruit of the lemon-tree is so well illustrated in the accompanying cut that description may be dispensed with. There are many varieties of the lemon, but they may all be included under the following four distinct types: (1) The Common or Genoa Lemon, which is the most plentiful in the shops, (2) The Thin-skinned Lemon, which is of large size, having a thin smooth shining fragrant rind, with an almost entire absence of white spongy matter beneath it. The pulp is very delicate and juicy, with a delicious aroma. (3) The Sweet Lemon, which, while having the external appearance of the lemon, has the pulp sweet like that of the orange. (4) The Citron Lemon, or the Ligurian Lemon of commerce. It is a large



Lemon (*Citrus Limonium*).

oblong fruit, with a thick rough warted rind, which is eatable. The pulp, however, is the least delicate of all lemons.

The peculiar and grateful flavour of the juice of the lemon is mainly due to citric acid. It forms, when properly diluted, an agreeable and refreshing drink (see LEMONADE), and is useful in febrile and inflammatory diseases. The most valuable of its properties, however, is the prevention and cure of scurvy; hence it or the very similar lime juice (see LIME) is an important article in sea stores. The well-known uses of the rind, either fresh or preserved, in the cook's and the confectioner's arts for flavouring and ornamenting dishes, cakes, and candies need only be alluded to, to show the importance of the lemon to civilised man. The essential oil (see below) is obtained from the rind. The lemon is largely cultivated in all the warmer countries of the south of Europe and those bordering on the Mediterranean, and it is naturalised in some parts of South America and in the East and

West Indies, and in parts of Australia. See Bonavia, *The Cultivated Oranges and Lemons of India and Ceylon* (1890).

The *Oil* or *Essence of Lemons* is extracted from the fresh lemon peel either by pressure or by distillation. The former is the usual method. The peel, removed from the fruit, is bent so as to rupture the oil vesicles, and the oil is collected in sponges, or the peel is sometimes rasped with short needles, and the exuding oil collected. The yield is variable, amounting on the average to 10 oz. of oil from 400 fruits. The oil has the same composition as that of turpentine—viz. $C_{10}H_{16}$, but it contains a small quantity of cymene and other oils. While it is often adulterated with turpentine, there is no doubt that the fragrant portion, even in genuine oil, can be removed, leaving about 90 per cent. of liquid having a decided turpentine odour. This fragrant portion, according to some authorities, is an oxygenated substance, and therefore differs distinctly from the bulk of the oil, which has the composition previously stated. Its chief use is as a flavouring agent, the ordinary essence of lemon of the shops consisting of a solution of the oil in alcohol. It also enters into most perfumes, such as *eau de Cologne*, &c.

The so-called *Salt of Lemons*, or *Salt of Sorrel*, is the binoxalate of potash. See OXALIC ACID.

Lemon. MARK, born in London, 30th November 1809, was educated at Chesham near Epsom, and in 1835 wrote a farce, the first of a long series of melodramas, operettas, &c. He produced, moreover, several novels (the best, perhaps, *Falkner Lytle*, 1866), children's stories, and essays, and appeared as a lecturer and public reader. In 1841 he helped to establish *Punch* (q.v.), of which for the first two years he was joint-editor with Henry Mayhew, and thereafter sole editor till his death, which took place at Crawley, Sussex, 23d May 1870. See Joseph Hatton's *Reminiscences of Mark Lemon* (1871).

Lemonade is formed by adding two lemons sliced, and two ounces of white sugar, to a quart of boiling water, and digesting till cold. It is a useful drink for allaying thirst, and as a refrigerant in febrile and inflammatory complaints, and in hæmorrhage, in which cases it should be given iced. Aerated Water (q.v.) flavoured with sugar and essence of lemons is also called lemonade.

Lemon-grass (*Andropogon schouranthus*), a perennial grass, a native of India, Arabia, &c., three to four feet high, and possessing a strong lemon-like fragrance. An essential oil is obtained from it which is used in perfumery. See GRASS-OIL.

Le Moyne, CHARLES, French pioneer, was born in Normandy in 1626, and, proceeding to Canada in 1641, lived among the Huron tribe of Indians, and fought with the Iroquois. In 1668 Louis XIV. made him Seigneur de Longueuil, and afterwards also de Chateauguay. He was for some years captain of Montreal, and died in 1683. Of his eleven sons, nearly all became distinguished. The eldest, Charles, Baron de Longueuil, was born in 1656, and in his youth served in the French army. He was made governor of Montreal and baron in 1700, and became commandant general of the colony. He died at Montreal in 1729. His descendant, Charles Colmar Grant, had his Canadian title of seventh Baron de Longueuil officially recognised by the Queen in 1880. Another son, Joseph, became an officer in the French navy, and in 1694-97 brought vessels to Hudson Bay to co-operate with land forces under his brother Iberville. He subsequently conveyed colonists to Louisiana, surveyed its coast, and aided in capturing Pensacola.

Lemprière, JOHN, was born in Jersey about 1763, and educated at Winchester and Pembroke College, Oxford. He was in turn head-master of Abingdon and Exeter grammar-schools, rector of Meeth in Devonshire and of Newton-Petrock, and died February 1, 1824. His famous *Classical Dictionary* (1792) remained for many years the standard work of reference in England on ancient mythology, biography, and geography. Another work of Lemprière's was *Universal Biography* (1808).

Lemur (Lat. *lemur*, 'a ghost'), a genus which has given its name to a large group of mammals, the lemurs. These animals appear to stand between the Insectivora and the monkeys. The hand with an opposable thumb is fashioned after that of the monkeys, but in most structural features they either show affinities to lower groups or are peculiar. The German name, 'Halb-Affen' ('Half-Apes'),



Ring-tailed Lemur (*Lemur catta*).

as also the term 'Prosimii,' which has been applied to the group, indicates its position at the base of the Primates. The Lemurs are forest-dwellers, and mainly nocturnal in their habits. They can be for the most part readily tamed. One of the chief points of interest attaching to the group is its peculiar geographical distribution. By far the majority of the genera are confined to the island of Madagascar; a few forms are found in the Orient, and on the African continent. Their range from Malaya to Madagascar has been accounted for by the supposed former existence of a continent (for which the name 'Lemuria' was proposed by Mr Selater) connecting these now widely-separated regions. Undoubted remains of these animals have, however, been found in Europe and in America; this of course indicates their wider range in ancient times; the isolation of genera at the present day is therefore probably due to the disappearance of forms occupying the intermediate tracts of country, and no Lemuria is necessary. Besides Lemur, the genera *Indris*, *Propithecus*, *Haplolemur*, *Sepllemur*, *Cheirogaleus*, and the curious and aberrant *Chiromys* (see AYE-AYE) are confined to Madagascar. The *Angwantilo* (*Aictocæbus*) and *Perodicticus* and *Galago* (q.v.) are African. The *Tausier* and *Nycticebus* are found in Malaya, and the *Loris* in Ceylon. Some of the fossil forms show affinities with the Insectivora, others with the Ungulata.

Lemures, the general designation given by the Romans to all spirits of departed persons, of whom the good were honoured as *Lares* (q.v.), and the bad (*Larva*) were feared as capable in their night

journeys of exerting a malignant influence upon mortals. The festival called *Leauria* was held on the 9th, 11th, and 13th of May, and was accompanied with ceremonies of washing hands, throwing black beans over the head, &c., and the pronunciation nine times of these words: 'Begone, you spectres of the house!' which deprived the lemures of their power to harm. Ovid describes the *Leauria* in the fifth book of his *Fasts*.

Leauria. See LEMUR.

Lena, a river of eastern Siberia, rises amid the mountains on the north-west shore of Lake Baikal, in the government of Irkutsk, flows first north-east to the town of Yakutsk, where it is 6½ miles wide, then north to the Arctic Ocean, into which it falls by several mouths, forming a delta 250 miles wide. Its course is 3000 miles in length, the area of its basin 772,000 sq. m. Its chief affluents are the Vilui (1300 miles) on the left, and the Vitim (1400), the Olekma (800), and the Aldan (1300) on the right. Navigation on the Lena is open from Yakutsk upwards from May till October. During spring the waters of the river regularly overflow their banks. The Lena is a principal artery of the trade of eastern Siberia. The riverine sand of the Vitim and Olekma yields richly in gold; salt, coal, iron, copper, and argentiferous lead exist. Large quantities of mammoth ivory have been found in the delta. See G. W. Melville's *In the Lena Delta* (1885).

Lenau, NICOLAUS, the pen-name of NICOLAUS NIEMESCH VON STREHLENAU, German poet, who was born at Czajad, near Temesvar in Hungary, 13th August 1802, and studied law, then medicine, at Vienna. But his was a melancholy nature; the compass of his soul ever trembled back to the pain of life. Although a man of deep feeling, and with a good deal of the true lyric inspiration, his life was rendered unhappy by his morbid poetic discontent. In 1832 he travelled to the United States, hoping to find there the peace and satisfaction which he could not get in Europe; but he returned in the following year a still further disappointed man. From this time he lived alternately in Vienna and in Stuttgart, in the latter city in close intimacy with the writers of the Swabian school (Schwab, Kerner, Mayer). On the eve of his marriage in 1844, he was suddenly struck down by insanity; he lived in an asylum at Oberdöbling near Vienna until his death, on 22d August 1850. Lenau's poetic power is shown to best advantage in his short lyric effusions, especially those (e.g. *Schilflieder*) associated with the land of his birth. His best longer pieces, as *Faust* (1836), *Sarastrofa* (1837), *Die Abtissin* (1842), cannot claim the merits of artistic completeness and unity, in spite of the rich fancy and feeling, and the fiery temper of the poet, displayed in individual passages. His *Sämmtliche Werke* appeared in 4 vols. in 1855, with a biography by Anastasius Grün. See Lives by Schurz (1855) and Frankl (1885).

Lenctos, NIXON DE, one of those characters that could have appeared only in the French society of the 17th century, was born of good family at Paris, 15th May 1616. Even as a child she was remarkable for her beauty and grace. She was carefully educated, spoke several foreign languages, excelled in music and dancing, and had a great fund of sharp and lively wit. At the age of ten she read Montaigne's *Essays*. Six years later she commenced her long career of licentious gallantry by an amour with the Comte de Chatillon to whom succeeded innumerable favourites, but never more than one at a time. Among her lovers we may mention the Marquis de Villareaux, the Marquis de Sevigné, the great Conde, the Duc de Lamoignon, Marshal d'Albret, Marshal

d'Estrees, the Abbé d'Elliat, and La Châtre. She had two sons, but never showed in regard to them the slightest instinct of maternity. The fate of one was horrible. Brought up in ignorance of his mother, he followed the rest of the world, and conceived a passion for her. When she informed him of the relation that subsisted between them, the unhappy youth was seized with horror, and blew out his brains in a frenzy of remorse—a calamity which did not seriously affect Ninon. She was nearly as celebrated for her manners as for her beauty. The most respectable women sent their children to her house to acquire taste, style, politeness. So great was her reputation that, when Queen Christina of Sweden came to Paris, she said she wished particularly to visit the French Academy and Ninon de Lenctos. We may gather some idea of her wit and sense from the fact that Laroche-foucauld consulted her upon his maxims, Molière upon his comedies, and Scarron upon his romances. She died 17th October 1706, at the age of ninety, having preserved some remains of her beauty almost to the last. Mirecourt's *Memoires* is a romance; the letters attributed to her are mostly spurious, but there is a notice of her letters to St Evremont in Sainte-Beuve's *Causeries du Lundi*. See also Capetigue's *Ninon de Lenctos* (Paris, 1864).

Lenecoran, a Russian seaport on the Caspian Sea, 130 miles S. of Baku. In the vicinity are celebrated sulphur-springs. Pop. 5540. It was surrendered to Russia by Persia in 1813. Excavations carried on here in 1890 yielded important prehistoric remains.

Lenecziza, an ancient Polish town, 80 miles WSW. of Warsaw. Pop. 15,546.

Lending. See LOAN.

Lenep, a town of Rhenish Prussia, 18 miles E. of Dusseldorf and 9 S. of Barnem, with manufactures of cloth, iron, &c. Pop. 8844.

Lenep, JACOB VAN, born at Amsterdam, 25th March 1802, is proudly called by his countrymen the 'Walter Scott of Holland.' The son of a professor of rhetoric who was distinguished as a Latinist and as a poet, he was educated for the bar, passed as a barrister, and soon achieved a great reputation for legal knowledge. Yet without neglecting his extensive practice he for more than thirty years cultivated literature with assiduity and success. Lenep first appeared as an author shortly before 1830 in a work on national legends, immediately followed by his comedies. His most popular works have been comedies, *Het Dorp aan die Grenzen* and *Het Dorp over die Grenzen*. Of his numerous novels several (including *The Rose of Dekema* and *The Adopted Son*) have been translated into English, French, and German. He wrote much for the stage, translated from Byron and other English poets, and published a Dutch history for the young. He died August 25, 1868.

Lennox (*Leenachs*, 'fields of the Leven'), an ancient Scottish territory, comprising the basin of the Leven and Loch Lomond—the whole of Dumbartonshire, great part of Stirlingshire, and portions of Perth and Renfrew shires. It gave name to an earldom (1174–1581), and then to a dukedom, conferred by Charles II. (q.v.) in 1680 on one of his illegitimate sons, Charles, Duke of Richmond and Lennox, who in 1702 sold the Lennox estates to the Marquis of Montrose. See GORDON; and *The Lennox*, by Sir W. Fraser (3 vols. 1874).

Lennoxtown, a village of Stirlingshire, 11 miles N. by E. of Glasgow by rail, with bleach works, print-works, and alum-works. Pop. 2838.

Lenormant, FRANÇOIS, an archaeologist and scholar of altogether exceptional genius, was born in Paris, 17th January 1817, the son of Charles

Lenormant (1802-59), himself profoundly learned in Egyptology, numismatics, and archaeology generally, moreover, a fearless defender of the faith. The boy was early initiated into the studies of his life, at twenty carrying off the prize in numismatics of the Academie des Inscriptions with his *Essai sur la Classification des Monnaies des Lagides* (1856). At twenty-three he was digging at Eleusis, and his explorations he continued, in the intervals of his work as sub-librarian at the Institute (1862-72), and professor of Archaeology at the Bibliothèque Nationale (1874-83), until his robust health finally broke down in Calabria from sheer over-work, together with the effects of a wound received when serving as a volunteer during the siege of Paris. He returned to Paris to die—a true martyr to science—December 9, 1883. Perhaps there was never a scholar who gained laurels from so many fields as Lenormant, and certainly no man ever brought to the study of the past a greater combination of exhaustive learning, wide grasp of detail, and brilliant intuition, with unwearied enthusiasm and luminous power of exposition. From numismatics and archaeology proper he passed perhaps too easily to Assyriology, comparative philology, ancient history, and biblical antiquities; still, he has left behind works of the greatest interest and value in these widely different fields. His divination rather than discovery of the existence of a non-Semitic element in the language of the cuneiform inscriptions—the Accadian—was perhaps his greatest contribution to science, but it was difficult to overpraise his essay on the propagation of the Phœnician alphabet, and his great and brilliant constructive work—one of the best attempts ever made to buttress the historical value of the early books of the Bible—*Les Origines de l'Histoire d'après la Bible* (3 vols. 1880-84).

Other works are *Manuel d'Histoire Ancienne de l'Orient* (3 vols. 1868-69; 9th ed. 1881, with a 4th vol. by Babalon, 1885); *Lettres Assyriologiques* (5 vols. 1871-79); *Les Premières Civilisations* (2 vols. 1874); *Les Sciences Occultes en Asie* (2 vols. 1874-75); *La Monnaie dans l'Antiquité* (3 vols. 1878-79); *Monnaies et Médailles* (1883); and *La Grande Grèce* (3 vols. 1881-84) and *A travers l'Apulie et la Lucanie* (2 vols. 1883).

Lens. A town of France, in the department of Pas-de-Calais, 17 miles by rail SW. from Lille. Here are coal-mines, sugar factories, sail-works, &c. Pop. (1891) 13,862. At Lens Condé defeated the Archduke Leopold on 20th August 1648.

Lenxes. A lens is a piece of glass so shaped as to refract rays of light really or apparently radiating from a point, and make them deviate so as to pass, or to travel on as if they had passed, through another point. Every system of lenses, however complicated and whatever be the mutual distances of the lenses, will, if the whole be centred on a common axis, produce a real image somewhere in front of, or else will appear to produce a virtual image somewhere behind, the last refracting surface. The rays on being traced through the complex combination—e.g. a telescope—undergo numerous deviations; ultimately there is a deviation which might have been equally produced by an *equivalent lens*; equivalent, however, in no other sense than as producing an equal ultimate deviation, for the image is not formed in the same place as the single 'equivalent lens' would have formed it in. The system of lenses is approximately equivalent in its action to a simple lens plus a determinate shifting of the focus. Hence a simple lens diagram, modified so as to represent this shifting, will represent the aggregate effect of the most complex system of lenses. When the subject was looked at from this point of view it was found by Gauss, followed up by Listing, that the whole theory of lenses can be treated generally; the most complex system of

lenses can be replaced in every case by a region of space traversed by the common axis of the lenses, at right angles to which axis there are six characteristic planes, the relative positions of which to some extent depend upon the refracting media and their forms and mutual distances, but which also present certain invariable properties and mutual relations. These six planes are (1) the incidental focal plane, F, (fig. 1); (2) the incidental principal plane, P, and (3) the incidental nodal plane, N; (4, 5, and 6) the refractive principal, nodal, and focal planes, P', N', and F'. The principal properties of these planes are: all pencils of rays

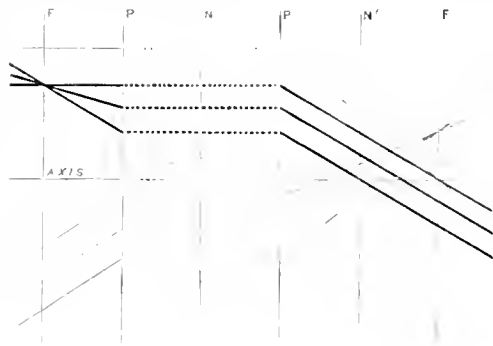

Fig. 1.

converging from any point on the incidental focal plane F (provided in this as in all other cases that no ray is so far from the axis as to give rise to spherical aberration) emerge parallel to one another; conversely, all rays incident parallel to one another come to a focus at a point in the second focal plane F'. An object on one principal plane, P, has an equal-sized image on the other, P'. Any ray appearing on incidence to make for the point where one nodal plane, N, cuts the axis, emerges parallel to its former course, but apparently coming from the corresponding point in the second nodal plane, N'. Rays arriving parallel to the axis pass on emergence through the axial point of the focal plane F'; rays passing through the corresponding point in plane F emerge parallel to the axis. These axial points are the Foci of the lens-system. These properties are diagrammatically shown, with exaggeration of the distances of the rays from the axis, in fig. 1.

In this diagram the six planes are represented as equidistant; they are generally not so; their

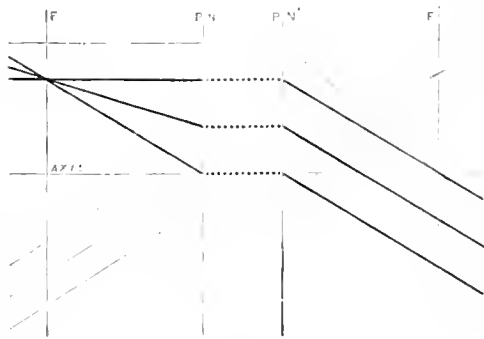

Fig. 2.

position has to be calculated. The calculation (see Pendlebury, *Lenses and Systems of Lenses*) necessitates the use of standard formulae involving

continued fractions; the physical principle underlying these is that the image (real or virtual) produced by one refracting surface is taken as the object of the next, and so on in succession until the position and deviation of the emergent rays is established. The fixed relations between the mutual distances of these planes are: $FN = PF'$; $F'N' = PF$; and $PF = F'P'/\mu$, where μ is the ratio between the refractive index of the final and that of the original medium. The matter is greatly simplified when, as in the ordinary case, the final and the original media are the same (lens or telescope in air); then $\mu = 1$, each nodal plane coincides with the corresponding principal plane, and $FP = F'P'$. The diagram takes the form indicated by fig. 2. If we come now to the simplest case, that of a single thick lens in air (fig. 3), the standard formulae, according to this method, are $AF = -\mu rr' / (\mu - 1) - tr / \Delta(\mu - 1)$; $AF' = \mu rr' / (\mu - 1) - tr' / \Delta(\mu - 1)$; $AP = -tr / \Delta$; $AP' = -tr' / \Delta$; and $PF = -PF' = -\mu rr' / \Delta(\mu - 1)$; where Δ stands for $\frac{1}{2}\mu(r' - r) + (\mu - 1)t$. In these formulae r is the radius of the A surface, measured towards the centre and towards the right; r' that

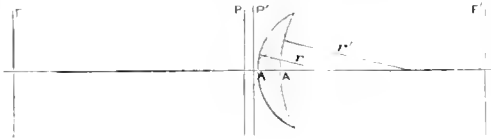

Fig. 3.

of the A' surface, measured in the same way; t is AA' , the thickness of the lens; μ is its refractive index as compared with that of the surrounding medium (air) = 1. As an example, let us apply these formulae to a biconvex lens of crown-glass, $\mu = 1.500$; let the radii be $r = +4$ inches at A and $r' = -6$ (negative because measured to the left) at A'; and let the thickness be 1 inch. Putting these numerical values instead of the letters in the formulae, we get $AF = -4.69$ inches; F is 4.69 inches from (to the left of) the A surface. $AF' = +4.55$ inches; F' is 4.55 inches from A'. $AP = -0.28$; the principal plane is to the right of A, inside the lens. $AP' = -0.41$; the second principal plane is to the left of A', inside the lens. The two principal planes are therefore both inside the lens, 0.31 inch apart, and are nearer the more curved face of the lens. The distance $FP = F'P'$, between either focus and the corresponding principal plane, is 4.96 inches, and this is the focal distance or the focal length of the lens; this, not the distance between the focus and the centre or the surface of the lens. The two focal distances are equal; hence if we could by reversing the lens make the principal planes exchange places, the action of the lens would be the same in both positions; but this cannot be done with an unsymmetrical thick lens by simply reversing it in its setting, on account of the unsymmetrical position of the planes within the lens. If we take the ten



Fig. 4.

cases in which the lenses are respectively: (1) biconvex (r positive, r' negative; equiconvex if $r = r'$); (2) planoconvex ($r = \infty$ and $r' < 0$); r'

(negative); (3) convexo-plane ($r +, r' = \infty$, $r' = 0$); (4) biconcave ($r -, r' +$); (5) planoconcave ($r = \infty, r' +$); (6) concavo-plane ($r -, r' \infty$); (7) convex meniscus ($r +, r' +, r'$ greater than r); (8) concave meniscus ($r -, r' -, r$ numerically greater than r'); (9) convexo-concave ($r +, r' -, r$ greater than r'); (10) concavo-convex ($r -, r' -, r'$ numerically greater than r)—we find, on giving the proper signs to the respective terms in the standard formulae above, that in lenses with a flat face one of the principal planes coincides with the vertex of the curved surface; that in all double concave and practically in all double convex lenses the principal planes are within the lens itself; that in lenses 7 and 8 the planes lie outside the convex face until the concave face is flattened so far as to draw one of them upon the lens; and that in lenses 9 and 10 the planes lie outside the concave surface until its curvature increases so far as to draw the nearer plane into the lens. We also find that in all simple lenses whose edges are thinner than their centres PF is negative (i.e. F is to the left of P), and the lens makes parallel rays incident upon it to converge upon some point in the opposite focal plane; while in thick-edged lenses PF is positive and P'F' negative, and the planes lie in the order F'P'PF, those rays which were parallel before incidence being divergent on emergence, and holding a course as if they had come from some point on that focal plane which lies on the same side of the lens as the source itself. When the incident rays are parallel to the axis and to each other, on emergence they converge really upon the opposite focus of a thin-edged lens or appear to diverge from the virtual focus of a thick-edged lens.

When the incident rays diverge from a point not on the focal plane they come to a focus at a definite point elsewhere than on the second focal plane.

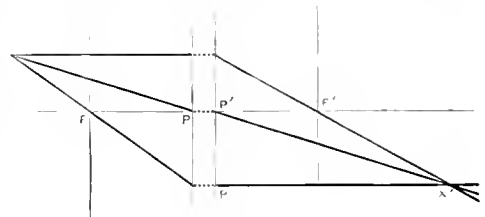

Fig. 5.

Fig. 5 diagrammatically illustrates this for a convergent lens. A pencil from X converges on X'; the geometry of the figure shows (by similar triangles) that $FP/XP + P'P'/X'P' = 1$. Hence, if PF or $P'F'$, the focal length, be written f , and the distances XP and $X'P'$ be written d and d' , then, numerically, $f(1/d + 1/d') = 1$. Fig. 6 illustrates

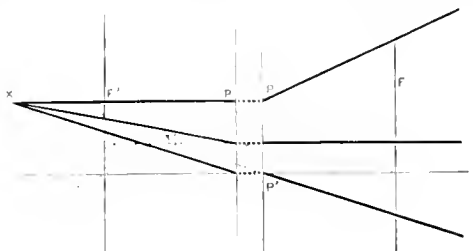

Fig. 6.

the same thing for a divergent lens: $FP/XP - P'P'/X'P' = -1$, or, numerically, $f/d - f/d' = -1$.

These equations give, numerically, the relations between d and d' , the distances of the object X and the image X' respectively from the corresponding principal planes P and P'. The general numerical formula which covers these relations is that if $d = XP$ and $d' = X'P'$ and $PF = P'F' = f$, f being taken as numerically negative in convergent and positive in divergent lenses, then

$$f \left(\frac{1}{d} + \frac{1}{d'} \right) = -1.$$

If an object occupy a plane passing through X at right angles to the axis, the corresponding image will (aberration apart) be in a similar plane passing through X'. Fig. 7 shows rays from three points of an object passing through the nodal points P and P' and emerging parallel to their former courses.

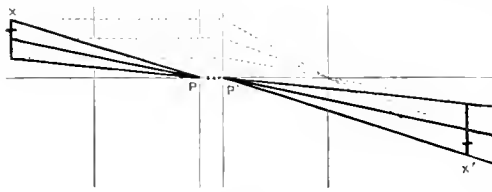

Fig. 7.

The size of the image is easily seen to be to that of the object as d' is to d . In a convergent lens the image of a distant object is inverted and *real*: there is a real crossing of rays in the image, and the real image is formed suspended, as it were, in space, invisible from points not in the path of the rays; a screen of card, of ground glass, or of tissue paper may be placed so as to coincide with the real image, which then becomes visible on the screen: if the eye be removed to a sufficient distance in the path of the rays the inverted real image in space itself becomes visible as an object in space between the lens and the observer, an inverted reproduction of the original object; and this inverted copy is, for all distances between the object and the lens exceeding twice the focal length, smaller than the original object, and for all such distances between twice and once the focal length it is greater than it. When the object is placed within the focal distance d is less than f , and d' is therefore numerically negative; the image is *virtual*; no screen will at any place receive an image; but the rays come to the eye *as if* they had proceeded from a larger object more remote from the lens on the original side of it; whence such lenses are commonly employed as magnifying glasses. Whenever the image formed is a real one the object and the image are interchangeable; an object placed in the position of the real image will produce a real image on a screen placed in the position of the original object. A comparison of fig. 6 with figs. 5 and 7 will show that the virtual image formed by a divergent lens is smaller than the object and is not inverted.

In all these cases the lenses are supposed to have an appreciable thickness. If, however, we assume that the thickness is negligible, the formulae given above are modified by suppression of all terms containing t ; they become simply $PF = AF = f = -r'r' / (\mu - 1)(r' - r)$, or $1/f = -(\mu - 1)(1/r - 1/r')$; and $AP = 0$. Whence the principal planes coalesce and blend with the surfaces; and the ordinary lens-formulae are obtained, in which f , the focal distance, means half the distance between the two focal points. The result is only approximate, as the numerical example already discussed will show when treated in this way. There $r = +4$; $r' = -6$; $\mu = 1.500$; whence $f = -\frac{1}{2} \left\{ \left(\frac{1}{4} + \frac{1}{6} \right) \right\}^{-1} =$

-4.8 inches, and the distance between the two foci is inferred to be 9.6 inches; whereas we have previously seen this distance (including PP') to be 10.24 inches. On the assumption now made, a lens is reversible; for in the formula we find that when the radii exchange places both change their signs, the result being the same. On giving the proper signs and numerical values to r and r' in the simplified formula, it is easy to arrive at the numerical value of f for a lens of any form: if f be negative, the lens is convergent (thin-edged); if positive, it is divergent. Then, f having been found, the relation between f , d , and d' can be found by giving d and f their proper signs and numerical values in the general equation $f/d + f/d' = -1$. If we find d' negative we infer a virtual, if positive a real image. For example, a crown-glass lens ($\mu = 1.500$), biconcave; $r = -4$ inches;

$$r' = +4; 1/f = -(1.5 - 1) \left(-\frac{1}{4} - \frac{1}{4} \right) = +\frac{1}{4}; f =$$

$+4$, a divergent lens. Object at distance, say, $d = 196$ inches; $\therefore d' = -196.50 = -3.92$ inches; a virtual image, smaller than the object in the ratio of 3.92 to 196, or one to fifty. Again, a similar lens, but biconvex; $r = 4$; $r' = -4$; $\therefore f = -4$ inches, a convergent lens. Let the object be at 204 inches; $d = 204$; $f = -4$; $\therefore d' = 4.08$ inches—a real image, smaller in the ratio of 4.08 to 204, or one to fifty. Let the object be at $d = 31$ inches; $\therefore d' = -28$ and the image is virtual, enlarged in the ratio of $28/31$, or eightfold, by the use of the lens as a magnifying glass. The nearer the object to the focus the greater the enlargement. To make the image equal in size to the object, d must be equal to d' ; then $-f/d + -f/d = -1 = -2f/d$; and $d' = d = 2f$. With a convergent lens adjust the positions so that the object and its image on a screen are of the same size; then they are at a distance of four times the focal length from each other. In this way, neglecting the thickness, the focal length of a convergent lens may be ascertained. It may also be ascertained by means of an object (spider-threads or a piece of muslin), and a telescope focussed for a very distant object; direct the telescope towards the spider-threads; interpose the lens to be examined; shift it until the spider-threads are distinctly seen in the telescope; the spider-threads are then in the focus of the lens, which causes the rays from them to pass parallel into the telescope. A divergent lens has its focal length measured by conjoining it with a convergent one, which neutralises or overbalances its effect; if $-F$ be the focal length of the convergent combination, $-f$ that of the convergent lens, and f' (unknown) that

of the divergent lens, $-\frac{1}{f} + \frac{1}{f'} = -\frac{1}{F}$; the deviation produced by a lens is inversely proportional to its focal length, and the equation states the proposition that the convergence produced by the one, together with the divergence produced by the other, is equal to the convergence produced by the combination.

When the light from an object is mixed the refractive index μ differs for each colour; the distance of the image is different for each spectral colour; thus a series of images are formed behind one another, the violet in front and the red behind; those behind are larger and overlap, and therefore the image appears to have a spectral fringe of colour, red outside. To prevent this chromatic aberration images of two or more colours, say the blue and orange, should be brought to the same plane and be of the same size; this is done for two colours or wave-lengths by combining a crown-glass convergent of excessive power with a flint-glass divergent lens; the curvatures are so chosen that the spectral dispersion produced by the one

is compensated by the re-combination produced by the other; but, since in the two materials the refractions and dispersions are not proportional to one another, there remains a balance of deviation accomplished without chromatic dispersion. Newton thought dispersion and deviation to be always proportional to one another, and achromatism therefore impossible; Dr Hall in 1733 found this not to be so, and made achromatic lenses, but did not publish his discovery. Dollond in 1757 first introduced achromatic lenses. When two colours are achromatised there is still some chromatic aberration as regards the rest; to bring a greater number of colours to the same focus requires a greater number of refracting surfaces.

In all the preceding it has been assumed that the lenses are narrow, or that the pencils of rays fall on the centre of the face, and that the objects are small. When the object is viewed by the lens under a wide angle a plane object gives an ellipsoidal, paraboloidal, or hyperboloidal image, which, when real, cannot be wholly received in focus upon a plane screen; and oblique rays fail to converge upon precise points, and hence, even on a screen so curved as to receive the oblique pencils of rays when at their greatest concentration, the image will not be equally distinct all over. Further (spherical aberration), if the lens be too wide, or its curvature too considerable, the rays falling on different zones of the lens are, as it were, received by prisms of different angle; those incident on exterior zones are more sharply refracted than those nearer the axis, and their focus lies at a point some distance nearer the lens than the geometrical focus (longitudinal aberration), and the image is thus distorted, so that the image of a square object formed by a single convex lens appears to be drawn out at the corners, and that formed by a concave lens appears to have its corners squeezed in; besides which there is blurring, for pencils incident near the edge have their foci not even on the axis, but short of it. To remedy these defects, which cannot all be thoroughly dealt with at the same time, various 'aplanatic' combinations of lenses of different curvatures have to be employed to build up a compound 'equivalent lens'; and these combinations have to be adapted to the particular purpose for which the lens-system is to be used (see Parkinson's and Coddington's *Optics*). The property of refracting light-rays possessed by lenses necessarily applies also to heat and actinic rays; whence the use of lenses as burning-glasses (in which parallel heat-rays from the sun are brought to a focus at the principal heat-focus of the lens) and photographic lenses. The heat-focus is somewhat farther, the actinic focus somewhat nearer to the lens than the light-focus is; but, by the application of the principles of correction for chromatic aberration, the visual and the actinic foci are, in the last case, made to coincide.

Lent (A.S. *Leuten* = Ger. *Lenz*, 'the spring'; Gr. *Tessaraktoste*; Lat. *Quadragesima*—hence Ital. *Quaresima*, Sp. *Cuaremas*, Fr. *Carême*), the period of fasting before Easter. Such an observance was old even in the days of Irenæus, but without any uniformity—some fasted one day, others two; but the period was gradually extended by the 4th century to about forty days. The Greeks from the 6th century have commenced their abstinence from meat on the Monday in Sexagesima week, and from cheese, &c. on the Monday in Quinquagesima week; Sundays and Saturdays and the Feast of the Annunciation being deducted. In the West only Sundays were excepted from the fast, which sometimes began with Sexagesima or Quinquagesima, until, in the 8th or 9th century, it was finally fixed to commence with Ash Wednesday (q.v.), between which day and Easter Sunday (omitting the Sun-

days, on which the fast is not observed) forty clear days intervene. The rigour of the ancient observance, which excluded all flesh, and even the so-called 'white meats,' is now much relaxed; but the principle of permitting but one meal, with a slight refectory or collation, is everywhere retained. In the Anglican Church Lent is retained as a church season of the calendar, with special services, and proper collects and prayers; but the observance of the fast is left to the discretion of each individual. See **FAST**; also **HOLY WEEK**.

Lenthall, WILLIAM (1591-1662), barrister, was born in Henley, entered St Alban Hall, Oxford, and was Speaker of the Long Parliament (1640-53). He was again made Speaker in 1654, and in 1656 became one of Cromwell's peers.

Lentibulariaceæ, a natural order of exogenous plants, allied to Primulaceæ. It has also intimate relations with Scrophulariaceæ. It contains nearly 200 known species, all herbaceous, and all living in water or marshes. They abound chiefly in the tropics. A few species of Bladderwort (see **INSECTIVOROUS PLANTS**) and Butterwort (q.v.) are its only representatives in Britain.

Lenticels. See **BARK**.

Lentil (*Ervum lens*), an annual plant belonging to the natural order Leguminosæ. It is a native of the countries bordering on the Mediterranean, and has been cultivated from the very earliest times. In Egypt and Syria it is still made into pottage, and another favourite mode of cooking it in those countries is by parching it in a frying-pan. The lentil is extensively cultivated in the warmer parts of Germany, France, and the south of Europe generally. It is also cultivated to some extent in Asia. The Hindus, in common with the Egyptians, regard it as the best food on which to undertake long journeys or laborious work. Flour of lentils is highly nutritious and contains, according to Playfair, more nitrogenous matter than any other edible leguminous plant. Einhoff found in 3840 parts of lentils 1260 parts starch and 1433 parts analogous to animal matter. The foods known as *Revalenta arabica* and *Erculenta arabica* (words compounded of the botanical name of lentil) are simply specially prepared forms of the flour of lentils, in no way superior to the ordinary flour which can be purchased at greatly less prices. Mixed with peas in the making of pea-soup, lentils diminish the tendency to flatulence, and lentil soup is much esteemed by vegetarians and others in Britain. By Roman Catholics lentils are eaten during Lent, both in soups and in the form of haricot, as a substitute for flesh-food. The lentil is a weak, straggling plant, rarely exceeding 18 inches high, often much more dwarfed, having pinnate leaves terminating in tendrils. The flowers are white, lilac, or pale blue, small, and formed like those of a pea. There are three varieties of lentil recognised in the countries in which it is cultivated: the small brown, which is



Lentil.

the lightest flavoured and the best esteemed for soups and haricots; the yellow variety, which is slightly larger; and the lentil of Provence, which has seeds as large as a small pea, but is better appreciated as fodder for cattle than for the grain as food for man. It has been frequently suggested that lentil might be grown as an agricultural crop in Britain, and its cultivation has been attempted, but without success, not so much from deficiency of warmth as from excess of atmospheric moisture. It is sown at the rate of about 1½ bushel per acre, and its cultivation and harvesting are similar to those of the Tare (q.v.), to which it is related. The produce in grain is fully a fourth less than that of the tare, and in respect of straw it does not yield a third of the weight of that crop. The grain, however, on the Continent sells at twice the price of peas.

Lentini, a town of Sicily, stands east of Lake Lentini, near the site of the ancient Leontini, 17 miles by rail S. by W. of Catania. Pop. 12,740.

Leo, the fifth sign of the Zodiac (q.v.).

Leo, the name of thirteen among the popes of the Roman Catholic Church, of whom the following call for particular notice.—**LEO I.**, surnamed 'the Great,' who is held a saint of the Roman Catholic Church, and is one of the most eminent of the Latin Fathers, was born of a distinguished family at Rome about the end of the 4th century. On the death of Sixtus III. in 440 Leo was chosen as his successor. It is in his pontificate that the regular series of papal letters and decretals may be said to commence. Leo's letters, addressed to all parts of the church, exhibit prodigious activity and zeal, and are used by Roman controversialists as an evidence of the extent of the jurisdiction of the Roman see. In a council held at Rome in 449 he set aside the proceedings of the Council of Ephesus, which had pronounced in favour of Eutyches (q.v.), summoned a new council at Chalcedon, in which his legates presided, and in which Leo's celebrated 'Dogmatical Letter' was accepted 'as the voice of Peter.' He interposed with Attila (q.v.) in defence of the Roman city and people, and subsequently with Genseric (q.v.). Leo died at Rome in 461. His works, the most important of which are his Letters and Sermons, were first printed in 1479, and afterwards by Quesnel (2 vols. Paris, 1675); but much better editions are those of Cacciani (1733-55) and Ballerini (1757). See books by Arendt (1835), Perthel (1843), Saint-Geron (1846), Gore (1889), and Felton (*Lib. Fathers*, xii., 1896).

The pontificate of **LEO III.** is chiefly noticeable as the epoch of the formal establishment of the Empire of the West. He was a native of Rome, and succeeded Hadrian I. in 795. During the greater part of the 8th century the popes, through the practical withdrawal of the Eastern emperors, had exercised a temporal supremacy in Rome, which was fully recognised by the gift of Pepin, and placed under the protectorate of the Frank sovereigns, who received the title of Patrician. The pontificate of Leo, however, was a troubled one, and in 799 he was treated with much violence, and obliged to flee to Spoleto, whence he afterwards repaired to Paderborn, in order to hold a conference with Charlemagne. On his return to Rome he was received with much honour by the Romans, and the chiefs of the conspiracy against him were sentenced to banishment. In the following year (800) Charlemagne, having come to Rome, was solemnly crowned and saluted emperor by the pope, and the temporal sovereignty of the pope over the Roman city and state was formally established, under the suzerainty, however, of the emperor. In 804 Leo visited Charlemagne at his court at Aix-la-Chapelle. With Charlemagne's

successor, Louis le Debonnaire, Leo was embroiled in a dispute about the right of sovereign jurisdiction in Rome, which had not been brought to a conclusion when Leo died in 816.

LEO X., Giovanni de' Medici, the second son of Lorenzo the Magnificent, was born at Florence in December 1475. From his cradle he was destined to the ecclesiastical career. His education was entrusted to the ablest scholars of the age; and through the influence of his father with Pope Innocent VIII. he was created cardinal at the unprecedented age of thirteen years, in 1488. In the expulsion of the Medici from Florence, after the death of Lorenzo, the young cardinal was included, and he used the occasion as an opportunity for foreign travel. He was employed as legate by Julius II.; and during the war with the French he was taken prisoner in the battle of Ravenna, but soon afterwards effected his escape. On the death of Julius II., in 1513, Cardinal de' Medici was chosen pope at the early age of thirty-seven, under the name of Leo X. His first appointment of the two great scholars Bembo and Sadoleto as his secretaries was a pledge of the favour towards learning which was the characteristic of his pontificate; but he did not neglect the more material interests of the church and the Roman see. He brought to a successful conclusion the fifth Council of the Lateran (see COUNCIL) and the schism which was threatened by the rival Council of Pisa. He concluded a concordat with Francis I. of France, which continued to regulate the French church till the Revolution. In the political relations of the Roman see he consolidated and, in some degree, extended the re-conquests of his warlike predecessor, Julius II., although he also used his position and his influence for the aggrandisement of his family. His desertion of the alliance of Francis I. for that of his rival, Charles V., although the subject of much criticism, was dictated by a sound consideration of the interests of Italy. But it is most of all as a patron of learning and art that the reputation of Leo has lived with posterity. Himself a scholar, he loved learning for its own sake; and his court was the meeting-point of all the scholars of Italy and the world. He founded a Greek college in Rome, and established a Greek press, which he endowed munificently (see RENAISSANCE). In the encouragement of art he was no less munificent. Painting, sculpture, architecture were equally favoured; and it is to his vast project for the rebuilding of St Peter's, and to the step to which he had recourse for procuring the necessary funds—his permitting the preaching of an indulgence, one of the conditions of obtaining which was the contribution to this work—that the first rise of the Reformation in Germany is ascribed. He himself seems to have regarded the movement as of little importance, describing it as 'a squabble among the friars;' and though he condemned the propositions of Luther, and issued a commission to inquire into his doctrines, his measures on the whole were not marked by much severity. His personal habits were in keeping with his taste—splendid and magnificent in the highest degree; but in his moral conduct he maintained a strict propriety, and his character, although not free from the stain of nepotism, the vice of that age, and more modelled on the ideal of an enlightened prince than on that of a zealous and ascetic churchman, was beyond all imputation of unworthiness or irregularity. His death, which occurred rather suddenly on 1st December 1521, during the public rejoicings in Rome for the taking of Milan, was by some ascribed to poison; but there seems no solid reason for the suspicion.

See Roscoe, *Life and Pontificate of Leo X.* (1805); Audin, *Histoire de Léon X.* (6th ed. 1886); Herzog-voth,

Leo's X. Regesta (1884 *et seq.*); Ranke, *History of the Popes*; Symonds, *Renaissance in Italy* (1875-86); M. Creighton, *History of the Papacy during the Period of the Reformation* (vols. iii, iv, 1887-91).

LEO XIII., the 258th Roman pontiff, was born at Carpineto, the son of Count Ludovico Pecci, 21 March 1810. Educated first at the Jesuit College of Viterbo and the schools of the Collegio Romano, he proceeded to the College of Noble Ecclesiastics. He greatly signalised himself in mathematics, physics, and philosophy. In 1830 he sustained a public disputation in the last-named branch of learning, and carried off the first prize. He also frequented the schools of the Roman University to learn canon and civil law. Having become Doctor of Laws, he was appointed by Pope Gregory XVI. a domestic prelate and Referendary of the Segnatura in 1837. He then took holy orders, received from the pope the title of protonotary apostolic, and was appointed in succession apostolic delegate at Benevento, Perugia, and Spoleto. He was a vigorous administrator, and while at Benevento put a stop to brigandage. Sent to Belgium as nuncio in 1843, he was created archbishop of Damietta to qualify him for the office. Three years later he was nominated archbishop of Perugia, and in the consistory of December 19, 1853, he was created a cardinal by Pius IX. He was a member of several of the congregations of cardinals—including those of the Council of Rites and of Bishops and Regulars—and in September 1877 he was selected by the pope to fill the office of Cardinal Camerlengo of the Holy Roman Church. In that important capacity he had control of all business except foreign affairs. Upon the death of Pius IX. in 1878 Cardinal Pecci was elected as the representative of the Moderates. He assumed the title of Leo XIII., and adopted an opposite policy to that of his predecessor. He restored the hierarchy in Scotland, and composed the religious difficulty with Germany, so that when a dispute arose in 1885 between Germany and Spain as to the ownership of the Caroline Islands he was requested by Prince Bismarck to act as arbitrator. In political matters Leo has permitted the Irish bishops to indulge their own views. In May 1888 the pope issued a decree denouncing the methods adopted in the Irish Plan of Campaign. He has manifested enlightened views in many directions, but on questions affecting the church and his own status as pontiff he has held staunchly to his rights. He regards himself as the deposed sovereign of Rome, and as a prisoner at the Vatican; has refused the income voted him by the Italian parliament; and persistently declines to recognise the law of guarantees. He has protested against heresy and 'godless' schools, and in his encyclicals has affirmed that the only solution of the socialistic problem is the influence of the papacy. He constrained the French clergy and the French monarchists to accept the republic, but encouraged the Hungarian Catholics to oppose the civil marriage law (1894). In 1883 he opened the archives of the Vatican for historical investigations, and he has made himself personally known as a poet, chiefly in the Latin tongue. The jubilee of his episcopate in 1893 was celebrated with even greater pilgrimages to Rome, congratulatory addresses, &c., than that of his priesthood in 1887. In 1896 he issued an encyclical pronouncing Anglican orders null and void.

See *Leo's XIII. Pont. Max. Carmina* (1883), and the *Lives* by De Waal (Munster, 1878), Vidien (Paris, 1879), O'Rilly (Cologne, 1887), Screlacs (Paris, 1894), Jeyes (1896), McCarthy (1896), Narfon (trans. 1899); see also his *Addresses*, &c., in *The Pope and the People* (1895).

Leo III., 'the Isaurian,' ruler (718-41) of the Byzantine Empire (q.v.).

Leo Africanus (properly ALHASSAN IBN MOHAMMED ALWAZZAN), a Cordovan Moor, who at the close of the 15th century made extensive travels in northern Africa and Asia Minor. Falling into the hands of pirates, he was sent to Rome, and accepted Christianity; but afterwards he returned to his old faith. He left an account of his African travels in Italian, which, first printed by Ramusio in 1559, was for long the chief source of information as to the Soudan.

Leobschütz, a town in Prussian Silesia, 24 miles by rail NW. of Ratibor, has large corn-markets. Pop. (1875) 11,425; (1895) 12,604.

Leochares, one of the most distinguished sculptors of the Attic school of the 4th century B.C., was a pupil of Scopas, and Pliny ascribes to him the sculptures on the west side of the Mausoleum (q.v.). He was one of the privileged artists who were permitted to make portraits of Alexander the Great. Three statues of Zeus are known to have been executed by him. His 'Ganymede carried off by an Eagle' was famous throughout the ancient world. In collaboration with Lysippos he produced a colossal group in bronze, which represented Alexander at a lion-hunt, while he himself was responsible for chryselephantine statues of Alexander and his family. The works of Leochares are all lost, but there is a copy of the Ganymede in the Vatican; and a bust of Alexander may be a copy of one of his.

Leo Hebraeus. See ABARBANEL.

Leominster (pronounced *Lemster*), a market-town of Herefordshire, on the Lug, 13 miles N. of Hereford. A monastery was founded here in 658; and the fine church of a later priory presents every style from Norman to Perpendicular. It was restored by Sir G. G. Scott in 1866, and enlarged in 1879. The quaint old timber Butter Cross (1633) was in 1855 transferred to a new site to make room for an Italian town-hall; there is also a coin exchange (1859). Leather gloves are the staple manufacture, and there is a great trade in hops and cider. Incorporated as a municipal borough by Queen Mary, Leominster till 1868 returned two members, and till 1885 one. Pop. (1851) 5214; (1881) 6044; (1891) 5675. See histories by Price (1795) and Townsend (1863).

Leon, an ancient kingdom of Spain, equivalent generally to the modern provinces of Leon, Palencia, Valladolid, Zamora, and Salamanca. It was the earliest Christian kingdom, next after Asturias, to be formed in Spain, after the Moorish wave of conquest began to recede. It dates from the 10th century, and was united with Castile first by Ferdinand the Great in 1037, and finally in 1230. The modern *province* has an area of 6165 sq. m. and (1887) a pop. of 380,229. The country, which is intersected by the Douro and the Minho, is mountainous, being invaded on the north by the Cantabrian Mountains. The soil is generally fertile. The inhabitants are for the most part uneducated and lazy, but honourable, hospitable, and good-natured; they have many peculiar customs, and all the pride of pure Spanish descent. In the high districts south of Salamanca there are remnants, as is believed, of the old Gothic tribes, and at Astorga the *Maragatos* are variously supposed to be descendants of the Celtiberi, the Visigoths, or the Moors.—Leon is also the name of a part of BRITANNY.

Leon (the *Legio septima gemina* of the Romans), capital of the former kingdom and of the modern province of the same name, but now a sleepy agricultural town, is situated in a plain, 256 miles

by rail NW. of Madrid. The beautiful cathedral (c. 1195-1512), a specimen of the purest Early Pointed, is French in character and probably in origin, but was so much 'restored' during 1855-86 that it is hard to say what is old and what modern; it contains the tombs of many sovereigns of Leon, saints, and martyrs. Leon is the centre of the Spanish linen-manufacture, and has a celebrated horse-fair; it was formerly the chief seat of the Spanish wool-trade. Pop. 13,446.

Leon, a city of Nicaragua, on an extensive plain, 32 miles by rail (1882) SE. of its port, Corindo. Once the boast of Spanish America, founded at the head of Lake Managua in 1523, removed hither in 1610, and sacked by Dampier in 1685, it is now partly in ruins, and of its noble buildings only the churches remain. The massive cathedral has been several times employed as a citadel during the civil wars, but has suffered very little. Pop., including the contiguous Indian pueblo of Subitaba, about 25,000.

Leon, PONCE DE. See PONCE DE LEON.

Leonardo da Vinci, painter, sculptor, architect, and engineer, was born in 1452, at Vinci, a village in the Val d'Arno, between Pisa and Florence, the natural son of Ser Piero Antonio da Vinci, notary to the Signoria of Florence. His mother, named Caterina, afterwards married a villager of Vinci. He was educated in his father's house, and soon began to show signs of that bright and versatile genius which distinguished him through life. As a child he was especially remarkable for his aptitude for arithmetic, and for his skill in music and drawing. About 1470 he was placed by his father in the studio of Andrea del Verrocchio, by whom he was instructed in painting and modelling, and where he had Perugino and Lorenzo di Credi as fellow-pupils. So rapid was his progress that before long he began to take part in the production of his master's pictures, and his hand can still be traced in Verrocchio's 'Baptism of our Lord,' in the Academy at Florence. In 1472 his name appears in the books of the guild of painters as an independent artist, and he was patronised by Lorenzo de' Medici. His cartoon of 'The Fall,' mentioned by Vasari as designed for tapestry, has disappeared; indeed of his work of this period, which included various marble figures and terra-cotta heads, all that now remains is an unfinished canvas of 'The Adoration of the Kings,' in the Uffizi, and a kneeling figure of 'St Jerome,' in the Vatican.

He would appear to have been about twenty-eight when he visited the East, serving as engineer to the sultan of 'Babylon' or Cairo, and visiting Cyprus, Constantinople, and Armenia; and in 1482 he settled in Milan, and attached himself to Lodovico Sforza, then guardian of his nephew the Duke Gian Galeazzo, whom he afterwards supplanted. An autograph memorandum, intended for presentation to his patron, still exists, in which, after stating his various qualifications as an architect and engineer, he concludes, 'I can execute sculpture, whether in marble, bronze, or terra-cotta; also in painting I can do as much as any other, be he who he may,' and particularly specifies his readiness to undertake the execution of a bronze equestrian statue of Lodovico's father, Francesco Sforza, the celebrated condottiere. Drawings for the general design and various details of this statue exist in the royal collection at Windsor. The model was exhibited in 1493; but the statue was destined never to be completed in metal, for the 100,000 pounds of bronze which Leonardo required for its casting were never forthcoming. The model still existed in 1501, but since then all trace of the work has been lost.

During the progress of this statue Leonardo was also engaged upon a picture which, even in its present faded and dilapidated condition, remains the best monument of his genius and one of the masterpieces of the world. This is the famous 'Last Supper,' commissioned jointly by the Duke and the monks of Santa Maria delle Grazie, to be painted on a wall of the refectory of the convent. It was completed in 1498, but its execution probably extended over several previous years. Baudello, in one of his novels, has given us a vivid glimpse of Leonardo at work upon this great subject; of the hushed voices of the monks and their visitors as they watched the busy figure painting there from early dawn, wholly absorbed in his pursuit, and forgetting even to eat; and of how the artist would sometimes leave the mounted figure of Francesco which he was modelling in the citadel and return to the convent by the shortest way, merely that he might add to his picture a single touch or two. The moment of his chosen scene upon which the painter has seized is that when Christ has just pronounced the words 'One of you shall betray me,' and their effect upon the disciples is portrayed with the most delicate and subtle truth. There is an elaborate description and criticism of the work from the pen of Goethe. The after-history of the 'Last Supper' is a sad one. Owing to the dampness of the wall, and to the method of oil-painting—not fresco upon plaster that had been adopted, it soon showed signs of deterioration, and it has repeatedly been found necessary to repaint it; yet still, through all the retouching of others, the profound feeling and dignified composition of the master do not fail to assert themselves. His sketches for various of its parts still exist at Windsor, in the Brera Gallery at Milan, and in the Louvre. It has been very frequently copied, and it was chiefly from a drawing made by Matteini from the copy by Marco d'Oggionno that Raphael Morghen executed his celebrated line-engraving, published in 1800.

Among other paintings done in Milan were portraits of Lucrezia Crivelli and Cecilia Gallerani, mistresses of the duke, works that cannot now be identified, though 'La Belle Ferronnière' of the Louvre has been regarded by some as the former likeness. The influence of Leonardo upon art in Milan was clearly marked and lasting, for he founded an academy there in which Beltrallio and Andrea Salai, his favourite pupil, received instruction; and the great Bernardino Luini, whether or not he actually studied under the master, certainly imbibed and turned to his own uses many of the characteristics of his method. Leonardo was also much employed by his patron as an engineer. He devised a system of hydraulic irrigation of the plains of Lombardy, and acted as director of the court festivities and pageants.

After the fall and imprisonment of the Duke Lodovico in 1500 Leonardo retired to Florence, and by 1502 he had entered the service of Cesar Borgia, then Duke of Romagna, as architect and engineer, in which capacity he was entrusted with the most ample authority. Records of his work during this period appear in the note-books and maps preserved at Windsor. In the following year he returned to Florence, when he commenced a Madonna and Child with St Anne for the Servite monks, a subject, however, of which only the noble cartoon now in the Diploma Gallery of the Royal Academy, London, was completed.

We now reach the period of Leonardo's famous contest with Michael Angelo, an artist who appears always to have regarded his elder rival with dislike and jealousy. Both painters received commissions to decorate the Sala del Consiglio in the Palazzo della Signoria with important historical composi-

tions. Michael Angelo chose a subject of 'Soldiers surprised while Bathing,' an incident from the Florentine wars with the Pisans. Leonardo dealt with 'The Battle of Anghiari,' 1440, in which the Florentines vanquished the armies of Milan. Two years were spent in the preparation of his cartoon; but, having employed a method of painting upon the plaster—probably with wax—which proved a failure, he in 1506 abandoned the work. The cartoon is now lost, but its general composition may be gathered from Lucensi's engraving (1558), and from 'The Battle of the Standard,' engraved by Edelinck from a free copy by Rubens of its principal group. About 1504 was completed the most celebrated of Leonardo's easel-pictures, the half-length of Mona Lisa, third wife of Zanobi del Giocondo, upon which he had been engaged at intervals during four years—a work purchased by Francis I. for 4000 gold florins, and now one of the chief treasures of the Louvre. The colour here, as not seldom in the artist's work, has darkened with time, but still the picture remains a triumph of subtle and refined portraiture. Another work, now lost, portrayed the celebrated beauty Ginevra Benet; and Pacioli's *De divina Proportione*, published in 1509, contained sixty geometrical figures from Leonardo's hand. As had been the case in Milan, so here in Florence he powerfully influenced contemporary artists. Fra Bartolommeo, Jacopo da Pontorno, Ghirlandajo, and the sculptor Bandinelli all profited by his example.

The final period of Leonardo's life was spent in the service of France. In 1506 he visited Milan; and in the same year he was employed by Louis XII., who died in 1515, when Leonardo was in Rome, competing with Michael Angelo for the execution of the facade of San Lorenzo in Florence. The young French king, Francis I., bestowed on him, in 1516, a yearly allowance of seven hundred scudi, and assigned to his use the Château Cloux, near Amboise; and it was here that the great artist expired, 21 May 1519. The well-known story that he died in the royal arms is untrue. Among his later works is 'The Virgin of the Rocks,' now in the National Gallery, London, of which a varying version is preserved in the Louvre, where also is another of his works of the time, a figure of 'St John the Baptist,' and a 'Saint Anne,' somewhat similar in design to the Royal Academy cartoon.

In his art Leonardo was hardly at all influenced by the antique; his practice was founded upon the most patient and searching study of nature. He occupies a supreme place as an artist in virtue of his unrivalled power of delicate draughtsmanship, of his nobility of style and command over the subtleties of expression, of his skill in chiaroscuro and easy mastery of the complexities of light and shade, of modelling and relief, and of aerial perspective. So few in number are the authentic, completed, and well-preserved works by his hand that have reached us that he may be most fully studied in his drawings. Rich collections of these are preserved in the Ambrosian Library, Milan; the Louvre, Paris; the Royal Gallery, Florence; the Albertina Gallery, Vienna; the Academy, Venice; the British Museum; and the Royal Library, Windsor. His celebrated 'Trattato della Pittura,' dealing with all departments of the painter's art, was published in Italian in 1651, translated into French in the same year, and into English in 1721; but a more complete manuscript was discovered by Manzi in the Vatican, and by him published in 1817. His contemporaries bear witness to the splendid personal appearance of Leonardo; but the only undoubted portrait of him that survives is the noble bearded head in the Royal Library, Turin, a red chalk drawing by his own hand.

The voluminous manuscripts of Leonardo, written from right to left—for the painter was left-handed—and evincing his profound research in almost every branch of science, are preserved at Paris, Milan, Windsor, in the British Museum, in the South Kensington Museum, and at Holkham. See Richter's *Literary Works of Leonardo da Vinci* (1883), and his *Leonardo* (Lond. 1880); Mrs Heaton's *Leonardo da Vinci and his Works* (1874); the fac-simile reproduction of his manuscripts by Ravaisson-Mollien (Paris, 1881-90) and by the Italians (1894 *et seq.*); and books by Uzielli (1872-85), Scailles (1892), and Eugène Muntz (trans. 1898).

Leonforte, a walled Sicilian town, 49 miles by rail W. by N. of Catania. Pop. 15,645.

Leoni, LEONE (1509-90), goldsmith, medallist, and sculptor, worked at Milan, Genoa, Brussels, and Madrid, and was the rival of Benvenuto Cellini in talent, in vice, and in violence. See the monograph by Plon (Paris, 1886).

Leonidas I., son of Anaxandrides, king of Sparta, succeeded his half-brother, Cleomenes I., about 491 B.C. When the Persian monarch Xerxes approached with an immense army Leonidas opposed him at the narrow pass of Thermopylæ (480 B.C.) with a force of 300 Spartans, and rather more than 5000 auxiliaries. The Persians attempted in vain to win over Leonidas by the promise of making him ruler of the whole of Greece; and when Xerxes sent a herald calling the Greeks to lay down their arms, the Spartan answered: 'Let him come and take them.' The treachery of one Ephialtes having made it impossible to bar any longer the progress of the foe, Leonidas and his little band, having sent away the auxiliary force, threw themselves on the swarming myriads, and found a heroic death.

Leonine City. See ITALY, p. 247.

Leonine Verses, irregular forms of Latin verse which arose in the middle ages under the influence of the minstrels, who applied the accentual system of verse to Latin in defiance of quantity. They were used for epigrams, satires, and also for the hymns of the church, and were fairly naturalised in Europe by the end of the 11th century. The name specially applies to verses rhymed as well as accentual, and more especially to groups of alternate hexameter and pentameter verses, rhymed at the middle and end. They owe their name to Leoninus, a canon of the church of St Victor, in Paris, about the middle of the 12th century, or, as others say, to Pope Leo II., who was a lover and improver of music. The finest poem in this form is the famous *De Contemptu Mundi* of Bernard of Morlais. A familiar example is the couplet:

De domo linguabat, monachus tunc esse volebat,
Ast ubi convaleuit, mansit ut ante fuit.

Another is the famous epitaph of Bede in the Galilee Chapel of Durham Cathedral:

Hic sunt in fossi Bede venerabilis ossa.

Traces of this kind of versification appear here and there in the Roman poets, especially in Ovid, in some of whose Epistles, indeed, they are as common on an average as once in every eight lines. An example from Ovid is

Quot eodem stellis, tot habet tua Roma puellas.

Camden gives some curious specimens from Walter de Mares, Michael, the Cornish poet, and Dan Elingham, a monk of Linton. The story of the Jew who, having fallen into a refuse-pit on Saturday, would not be helped out, because it was *his* Sabbath, while the Christian, who offered him assistance, refused to do so *next* day, because it was *his*, runs thus in Leonine verse:

Tende manus, Salomon, ego te de stercore tollam;
Sabbata nostra ubi, de stercore surgere nolo;
Sabbata nostra quidem, Salomon, celebrabis ibidem.

We find the same metrical device employed in many English poems, as in Shelley's *Cloud*.

Leontius of Byzantium, a monk who wrote against various heresies in the 6th century. There is a monograph on him (in German) by Loofs (1887).

Leopard (*Felis pardus*), one of the larger Felidae (q.v.), now generally supposed to be identical with the panther. Great confusion has prevailed in the nomenclature: the *panther* and *pardalis* of the ancients are not certainly known; the jaguar was erroneously described as the panther by Bullion; the puma is often called panther in America; the leopard is known by the name of

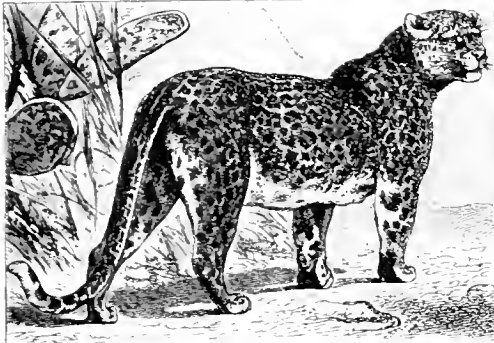

Leopard (*Felis pardus*).

tiger in Africa; and, as Sir J. E. Tennent tells us, it is by mistake often called cheetah in Ceylon. The leopard is at home in Africa, from Algeria to Cape Colony; it is also found in Asia, from Palestine through central Asia to Manchuria. The ancients, distinguishing the leopard by non-existent attributes from the panther, gave it the name on the supposition that it was a hybrid between the lion (*leo*) and the pard or panther (*pardus*); as the giraffe or camelopard was thought to be a hybrid of the camel and the pard.

Supposing the leopard and panther to be one species, we may describe it as characterised by a peculiar gracefulness, slenderness and flexibility of form, with a very long tail, and spotted fur, the spots being arranged in numerous rows along the sides, and each spot composed of five or six small spots arranged in a circle or rosette. The general colour is yellowish; the lower parts lighter; the spots darker than the general colour of the fur. A black variety is known which is not a distinct species. The leopard is extremely agile, and possesses the power of leaping and also that of climbing trees in great perfection. It haunts wooded places, and is seldom to be found in open regions of long grass, like the tiger. Deer and antelopes are its habitual prey; but it is equally ready to feed on pigs, poultry, or whatever animals may be found in the vicinity of a farm or village. The size and strength of the leopard render it as dangerous to man as any of the Felidae; but it generally seems to dread and flee from man, unless assailed. It is very capable of domestication.

Leopardi, GIACOMO, the most distinguished poet of modern Italy, was born at Recanati, in the March of Ancona, 29th June 1798. Both his parents were noble; but both were poor. The conditions of Leopardi's early life were certainly un congenial, though his inherited temper disposed him to exaggerate everything distasteful to his own instincts. His father had the predilections of a scholar; but in religion and politics he was a reactionary, and in the management of his family unsympathetic and arbitrary. From the first there

was no real bond of sympathy between father and son, and the mother, though kindly and conscientious in the discharge of her duties, does not seem to have touched her son's heart. All through his boyhood Leopardi was an omnivorous reader; and his faculty of acquisition can be compared only to that of the younger Scaliger. By the age of sixteen he had read through all the Latin and Greek classics, and could write with accuracy French, Spanish, English, and Hebrew. That he also read with insight is proved by the fact that at sixteen he wrote a commentary on Plotinus, of which Sainte-Beuve could say that 'one who had studied Plotinus all his life could find something useful in this work of a boy.'

Leopardi was unhappy at home; and, conscious of his own extraordinary gifts, he eagerly desired to visit Rome, where he hoped to find the ideal world of the scholar and man of letters. From conscientious though petty scruples, his father long opposed this wish; but at length, in the strangely mistaken hope that Giacomo might at Rome be led to enter the church (for which he had been originally intended), he gave his permission (1822). A year's residence in Rome wrought in Leopardi a disillusion, which gave the final bent to his fundamental views of life. It was the time, it is to be remembered, when Italy was demoralised by the French domination; and in Rome itself the tone even of the best society was despicable. An acquaintance with Niebuhr and Bunsen, both of whom spoke of him as a prodigy, was almost the sole redeeming experience in the capital of Italy. It was with feelings of relief, therefore, that in 1823 he returned to Recanati. For the next ten years, partly of choice, but also largely of necessity, he devoted himself to literature. From his earliest days he had been of feeble and sickly constitution, and as he grew older his ill-health became more frequent and overmastering. As a confirmed invalid, he lived successively in Bologna, Florence, Milan, and Pisa, and finally quitted Recanati in 1830. In 1833 he accompanied his devoted friend Ranieri to his house in Naples, and there in constant bodily anguish and hopeless despondency he lived till 1837. He died on the 14th of June in that year.

Leopardi claims recognition at once as a scholar, a poet, and a thinker. Had his health permitted, and had he so chosen to devote his powers, there can be no question that he would have taken his place in the front rank of the students of antiquity. Immediately subsequent to his death the original productions of Leopardi were classed with the highest creative efforts the world has seen. His *Operette Morali*, consisting mainly of dialogues in which he expounds his peculiar philosophy, were compared for originality and power with the writings of Pascal, the writer whom he at least most closely resembles in tone of mind as well as in physical constitution. As a poet it was asserted that Dante alone of all the Italians was his equal in expressiveness of character and genius. Of late years, however, a more sober estimate has been formed of Leopardi's claims both as a poet and thinker. It is now generally recognised that his narrow range of sympathy and the essentially feeble spring of his nature debared him from the highest creative effort. The pessimism of which he is the recognised exponent in poetry, and which is equally the burden of his prose, was unquestionably the genuine expression of Leopardi's deepest nature as well as of his reasoned conviction. The note of pessimism has often been sounded by other poets besides Leopardi; but it remained for him to extract its full poetic context from a philosophy, the first and last word of which is the 'void and nothingness' of all human life and effort.

The works of Leopardi were edited in 1845 at Florence by Rameri in six volumes. The most noteworthy of his writings are, in poetry, his *Canto* and *Canzoni*, and a piece entitled 'Continuation of the Battle of the Frogs and Mice'; and, in prose, the Dialogues and Essays classed under the title *Operette Morali*. His Essays and Dialogues were translated into English by Charles Edwardes in 1882, his Poems by Frederick Townsend in 1888. See Gladstone's *Gleanings*, vol. ii.; Sainte-Beuve, *Portraits Contemporains*, tom. iii.; and Antona-Traversi, *Studi su Giacomo Leopardi* (Naples, 1888).

Leopold I., king of the Belgians, son of Francis, Duke of Saxe-Coburg, and uncle of Queen Victoria, was born at Coburg on 16th December 1790. After receiving an excellent literary and scientific education, he became a general in the Russian army, and was present at the battles of Lützen, Bautzen, and Leipzig. Whilst on a visit to England after the peace of 1815 he won the affections of the Princess Charlotte (q.v.), the heiress of the throne, married her, and was naturalised by act of parliament in 1816. The princess died in 1817; and Leopold twelve years later marriedmorganatically Caroline Bauer (q.v.). He received in February 1830 the offer of the crown of Greece, accepted it under conditions, but abdicated in May. In June 1831 he was elected king of the Belgians, and crowned at Brussels 21st July. As a monarch he conducted himself with great prudence, firmness, and moderation, with constant regard to the principles of the Belgian constitution. He died 10th December 1865, and was succeeded by his son, Leopold II. See BELGIUM, CONGO.

Leopold, PRINCE. See ALBANY.

Lepage. See BASTIEN-LEPAGE.

Lepanto (anc. *Naupactus*), now called by the Greeks Epakto, a small town of Greece, and the seat of a bishop, is situated on the north side of the entrance to the Gulf of Corinth. During the Peloponnesian war it was one of the chief naval stations of the Athenians. In the middle ages it was given by the Byzantine emperor to the Venetians, who fortified it so strongly that in 1477 it stood a siege of four months by 30,000 Turks, and in 1499 was only taken by Bajazet II. at the head of 150,000 men. Near Lepanto took place the celebrated naval battle between the Turks on the one side and the Papal galleys, and those of the Venetians and the Spaniards, on the other, on 7th October 1571, in which the Christians, commanded by Don John of Austria (q.v.), achieved a decisive victory. Of the Turks 30,000 fell or were taken prisoners, whilst 130 Turkish vessels were captured, and 12,000 Christian slaves liberated; the Christians lost 8000 men and 15 galleys. In this battle Cervantes lost an arm. The town became Greek in 1829.

L'Épée. See ÉPÉE.

Lepidodendron, a genus of fossil plants which occurs in Carboniferous and Upper Devonian strata. Several species are recognised, most of which attained a large size—40 or 50 feet long and more than 4 feet in diameter. They were tree-like lycopods, their living representatives being the low-growing club-mosses of our mountains. The stem tapered upwards and branched dichotomously, and was either covered with linear one-nerved leaves, or where these had fallen was marked with more or less prominent ovate or lozenge-shaped leaf scars, arranged in a spiral manner. The fruits, which were either terminal or lateral, were elongated, cylindrical bodies, composed of a conical axis, around which a great quantity of scales were compactly imbricated. The fossils described under the name *Kuorria* are now known to be the decorticated stems of *Lepidodendron*. So again the fruiting branches were formerly included under the genus

Halonia, while the cones were named *Lepidostrobus*. Some of the roots (*Stigmaria*) met with in the underclays of the coal-measures also appear to belong to *Lepidodendron*.

Lepidoptera (Gr. 'scaly-winged'), an order of Insects (q.v.). See also BUTTERFLY, CATERPILLAR, MOTH.

Lepidosiren (Gr. 'scaly siren'; *L. paradoxo*), one of the mud-fishes or Dipnoi, a native of Brazil, Paraguay, &c., but rather rare. It measures about 4 feet in length, and is probably carnivorous. Its general characters, along with those of the two other genera, *Ceratodus* (q.v.) and *Protopterus*, will be described under MUD-FISHES.

Lepidosteus. See BONY PIKE.

Lepidus, an illustrious Roman family of the ancient Æmilian gens. MARCUS ÆMILIUS LEPIDUS, when war broke out (49 B.C.) between Cæsar and Pompey, declared for Cæsar. During his own absence in Spain, Cæsar made Lepidus dictator of Rome and his colleague in the consulate (46 B.C.). He afterwards supported Antony, and became one of the trimvirate with Octavianus and Antony; but his weakness of character made him inferior to the other two, who assigned him Africa as his province (40-39 B.C.). Ultimately his legions deserted to Octavian, who allowed him to retain his wealth and the dignity of pontifex maximus. He died 13 B.C.

Le Play, FREDÉRIC (1806-82), engineer and economist, was professor in the School of Mines at Paris, and a senator. He was a commissioner at several exhibitions, and wrote *Les Ouvriers Européens* (1855), *La Reforme Sociale* (1864; 7th ed. 1887), *L'Organisation du Travail* (1870; 5th ed. 1888), on the family, on the English constitution, *La Constitution essentielle de l'Humanité* (1881), &c.

Leprosy. The terminology of this disease is somewhat confused; it was called by the ancients *elephantiasis* and *lepra*, but the latter term at least was also used of other forms of disease (of psoriasis, for example). In modern times, too, both these names have been applied to other diseases as well; *Elephantiasis Arabum* (q.v.) is distinct from leprosy, which is distinguished as *Elephantiasis Græcorum*, or *Lepra Arabum*. It is also sometimes called *Leontiasis*.

History and Distribution.—It is highly probable that what is now known as leprosy was one of the diseases, though certainly not the only one, spoken of by that name in the English Bible; Leviticus xiii. deals specially with the rules for the detection and isolation of cases of leprosy. It is not mentioned there prior to the sojourn of the Israelites in Egypt. It is worthy of note that it was regarded by the earlier Greek and Roman writers as an Egyptian disease. But it certainly existed in India and China at very early periods. Regarding its first appearance in Europe nothing is known. It has been supposed that it was brought from the East by the Crusaders; but there is evidence that it was prevalent long before the first crusade. During the middle ages it was extremely common; leprosy-houses, dedicated to St Lazarus (from whom lepers were called also lazars), existed throughout Europe, including the British Islands, for the reception of lepers, though in all likelihood not for them exclusively. Efforts were made to secure stringent isolation. The old Jewish leper with his rent garments and melancholy cry, 'Unclean! unclean!' was reproduced in the medieval leper, with a gray gown and a clapper to announce his approach. Since about the 14th century leprosy has been steadily declining in Europe. From Shetland where (as also in Cornwall) it lingered long, :

leper, of a leprous stock, was sent to Edinburgh Infirmary in 1798, and a few cases occurred in the beginning of the 19th century. Liberton, near Edinburgh, is believed to take its name from the leper-house established there.

At the present day the only part of Europe where it is common is Norway; but it also occurs in Iceland, on the Russian coasts of the Baltic and Gulf of Finland, in south Russia, in Portugal, Spain, Italy, Turkey, Greece, and many of the Mediterranean islands. Everywhere in Europe, however, it is found only in limited districts. In Africa it is met with almost all round the coast and in the adjacent islands. In Asia it occurs in all the countries and most of the islands on the south, from Arabia and Persia to China and Japan. In America it occurs in New Brunswick, in Central America, the West Indies, and the northern and eastern parts of South America. In the United States and in Australia cases have occurred, but almost all among the Chinese immigrants; in New Zealand it is much more common among the natives. In the Sandwich Islands it seems to have first appeared about 1850, but has spread with alarming rapidity; it is also met with in some others of the Pacific islands (for the leper island of Molokai and its institution, see HAWAII). The exclusion of lepers is in most places carefully aimed at. Larger or smaller leper-hospitals are found in all countries where lepers are numerous; notable ones being at Bergen, Tracadie (in New Brunswick; administered by devoted religious sisters), Robben Island (near Cape Town); there are upwards of a dozen in India.

Course and Mode of Spreading.—The above list of localities is enough to show that the disease is not dependent upon climate. There has been a general belief from time immemorial in countries where it occurs that it is contagious; but, though numerous cases are met with of persons temporarily residing in districts where the disease is prevalent who have become affected by it, instances are extremely rare in which they have communicated the disease to others in countries where it is not endemic; and if it is contagious, it must be under very rare and exceptional conditions. Almost all qualified observers, however, believe that the disease, or a constitutional tendency to it, is strongly hereditary. Evidence has recently been adduced which seems to show that it may be communicated by vaccination from a leprous child. Insanitary conditions, filthy habits, and unwholesome food are generally believed to favour its occurrence; though persons in comfortable circumstances are by no means exempt. Some authorities, among whom Mr Jonathan Hutchinson is prominent, think that 'in some way fish-food, and especially when either salted or decomposed,' is the main cause of its origin. In 1874 Hansen of Bergen found a bacillus, extremely like the bacillus of tubercle, afterwards discovered, in the affected tissues; and his observations have been confirmed by many other observers, so that there is no doubt that this organism is a constant feature of the disease.

Symptoms and Course.—The disease is usually very slow and insidious in its appearance and progress. The earliest symptoms are debility, depression, loss of appetite, and general constitutional disturbance. Two forms of the disease are recognised, *tubercular* and *anæsthetic* leprosy, according to the tissues first and chiefly involved. In the tubercular form the earliest recognisable change consists in the appearance of reddish-brown spots on the skin, usually of the limbs, tender to the touch, and somewhat swollen. They may disappear, leaving the skin only slightly thickened; but repeated attacks occur and affect wider areas; ultimately the skin of the face becomes thickened,

puckered, and nodulated, giving a peculiar, heavy, morose expression; the hands and feet become similarly affected; some of the nodulated spots form into deep intractable ulcers; owing to changes in the cornea the sight is dimmed or lost; the mucous membrane of the mouth and throat becomes thickened, and the voice reduced to a hoarse whisper. In the anæsthetic form certain of the nerves are chiefly affected, and before any visible changes occur sensation is lost in the areas of skin supplied by them. Mutilation of the fingers and toes often occurs, the bones being destroyed, or the whole parts dropping off, often without pain. This form is generally slower in its progress than the tubercular form, but frequently leads to the development of the latter. In whatever way the disease begins, the constitution is slowly enfeebled, and the sufferer falls a ready victim to some intercurrent malady; for leprosy is seldom itself the direct cause of death.

Treatment.—The disease may under favourable conditions remain quiescent for long periods. In the Tracadie lazaretto there have been patients who have suffered from leprosy for fifty years. Cases have even been reported of complete recovery. Improvement has sometimes followed the use of Gajjun (q.v.) and Chaulmoogra oils. But in the vast majority of cases no treatment has proved of any use in arresting the progress of the disease.

See a monograph on True Leprosy by Liveing (1873); and the works on Skin Diseases by Wilson, Hutchinson, and others. For mediæval leprosy, see Sir J. Y. Simpson in *Edin. Med. and Surg. Jour.* (1846-47); for leprosy in India (where in 1888 there were 135,000 lepers, or, according to other estimates, 250,000), see Vandyke Carter's work (1873); for leprosy on Robben Island, see *Blackwood's Magazine* for 1889.

Lepsius, KARL RICHARD, Egyptologist, was born at Naumburg, 23d December 1810. His father, Karl Peter Lepsius (1775-1853), a magistrate there, was himself a zealous antiquary, and published learned treatises on the local antiquities. The younger Lepsius studied at Leipzig, Göttingen, Berlin, and Paris. His first work was *Die Palæographie als Mittel der Sprachforschung* (1834), for which he obtained the Volney prize of the French Institute. This was followed by works on the most ancient alphabets and other kindred subjects. In 1836 he associated himself intimately with Bunsen at Rome, and eagerly prosecuted his favourite studies there. Between 1834 and 1842 he published his *Lettre à M. Rosellini sur l'Alphabet hiéroglyphique*, and, in the *Transactions* of the Archaeological Institute, a number of dissertations on the monuments of Egyptian art and their general architectural style. He also applied himself to the study of the ancient Etruscan and Oscan languages, the remains of which he published in his *Inscriptions Umbricæ et Oscæ* (1841) and other works. In 1842 he was placed at the head of an antiquarian expedition sent to Egypt by the King of Prussia, and on his return three years later was appointed ordinary professor in Berlin. His *Denkmäler aus Aegypten und Aethiopien* (12 vols. folio, with 963 plates, 1849-60) was published at the expense of the King of Prussia, and remains a masterpiece of patient genius and erudition. His *Chronologie der Aegypter* and *Ueber den ersten Aegypt. Gotterkreis* laid the foundation for a scientific treatment of the earlier parts of Egyptian history. To the study of Egyptian archaeology he joined the investigation of the languages, history, and monuments of the regions farther up the Nile. Other works are his letters from Egypt, Ethiopia, and Sinai (1852); a communication on the Egyptian monuments (1853); the work in which he expounds the *Standard Alphabet*, a modified Roman alphabet for hitherto unwritten languages, now used in many cases

(1855; in its second edition, published in English in 1863, adapted to 120 languages); a work on the Egyptian ell and other measures; the *Königsbuch*, a list of kings (1858); the *Todtenbuch* (1867), the Egyptian Book of the Dead (q.v.). He wrote also on Chinese, Arabic, and Assyrian philology; was editor of the Berlin *Zeitschrift* of Egyptology, member of the Royal Academy, director of the Egyptian section of the Royal Museum, and chief-librarian of the Royal Library at Berlin. He was a creator of Egyptology as a scientific study, and a devoted and single-minded scholar of the best type. He died 10th July 1884. See Ebers, *Richard Lepsius, ein Lebensbild* (1885; Eng. trans. New York, 1887).

Leptospermum, a genus of trees and shrubs, natives of Australia, New Zealand, &c., of the natural order Myrtaceae, sub-order Leptospermeae. They are evergreen, with leaves somewhat resembling those of myrtles. Some bear the name of Tea-tree, as *L. lenigerum*, *L. barbatum*, *L. fluosum*, and *L. grandiflorum*, because the leaves have been used as a substitute for tea. *L. scoparium* is sometimes called the *New Zealand Tea-plant*, sometimes the *Brown tree* or *Doopwood-tree*. It is common both in New Zealand and Australia.

Lerida, a town of Spain, capital of the province of Lerida (area, 4762 sq. m.; pop. 285,417 in 1887, having decreased from 314,530 in 1860), on a tributary of the Ebro, 114 miles by rail W. by N. of Barcelona. The second city of Catalonia, Lerida has a castle and two cathedral churches, one an ancient Byzantine-Moorish edifice, now used as a barracks, the other a modern Græco-Roman building. It carries on manufactures of woollens, cottons, leather, paper, and glass. Pop. (1877) 203,369; (1884) 17,672. Near Lerida, the Celtiberian *Herda*, Scipio Africanus defeated Hanno (216 B.C.) and Cesar, the lieutenants of Pompey (49 B.C.). The Goths made it a bishop's see and held here a council of the church in the 6th century. In 1300 a university was founded here; it is now extinct. The town has been several times besieged, on the last occasion by the French in 1810.

Lérins, a small group of French islands in the Mediterranean, 2½ miles SE. of Cannes. On Sainte-Marguerite (the ancient *Lerina*), 4 miles in circumference, stands a fortress in which the Man with the Iron Mask and Marshal Bazaine were at different times confined, and from which Bazaine escaped in 1874. On Saint-Honorat (anciently *Lerina*), 2 miles in circuit, are the ruins of the once famous monastic school. Vincent Lérinensis, a monk here (died 450), was the author of the famous definition of Catholicism (see CATHOLIC CHURCH).

Lermontoff, MIKHAIL YUREVITCH, one of Russia's greatest poets, called the 'poet of the Caucasus,' was born, of Scotch extraction (Learmont; probably traceable back to Thomas the Rhymer), in Moscow on 15th October 1814. He was educated at Moscow and in the school of pages at St Petersburg, and, entering the army, was sent on active service in the Caucasus. There he was shot dead in a duel on 15th July 1841. The death of Pushkin gave him his first poetic inspiration, which took shape in an impassioned appeal for vengeance on Pushkin's slayer. But it was the sublime scenery of the Caucasus that inspired his best poetic pieces, such as *The Novgorod*, *The Demon*, *Ismaïl Beg*, *Valerik*, &c. One poem from his pen, *The Song of the Captive Anna Vasilievitch*, is highly praised as a successful attempt to reproduce the spirit of the Little Russian popular poetry. A Byronic note runs through most of Lermontoff's poetic work. In 1839 he published a good novel, *A Hero of Our Time*; this is said to have occasioned the duel that cost him his life. See Turner, *Studies in Russian Literature* (1883);

Blackwood's Magazine (1884); and George Brandes, *Impressions of Russia* (1890).

Lernaïda, a family of Copepod crustaceans, of which the females are parasitic on fishes and grotesquely degenerate, the adults showing hardly a trace of crustacean structure. See FISH-LOUSE.

Leroy de St Arnaud. See ST ARNAUD.

Lerwick, (the county town of Shetland, on the east coast of Mainland and on Bressay Sound, 116 miles NE. of Kirkwall. Demolished and refounded in the 17th century, it has been greatly improved since 1850, and has a town-hall (1883), county buildings (1872), water and drainage works (1871); whilst, to meet the rapid growth of its shipping and fisheries, extensive harbour-works (pier, wharves, &c.) were carried out during 1883-86. Pop. (1831) 2750; (1881) 4045; (1891) 3930.

Le Sage, ALAIN-RENE, was born in 1668 at Sarzeau in Brittany. His father died in 1682, leaving him to the care of an uncle, who so mismanaged his affairs that he began life with little more capital than genius and an education received at the Jesuit school at Vannes. In 1692 he went to Paris to study law, but an early marriage drove him to seek a less tardy livelihood in literature. His first work was a translation of the letters of Aristænetus in 1695, and about the same time he made the friendship of the Abbé de Lionne, who was owner of a good Spanish library collected by his father the ambassador, of which he made Le Sage free, with a pension of 600 livres to enable him to profit by it. The first fruit was the project of a *Théâtre Espagnol*; but all that came of it was one volume in 1700 containing two plays, the *Traître puni* and *Don Felix de Mendore*, imitated from Rojas and Lope de Vega. In 1702 *Le point d'honneur*, from *No hay amigo para amigo* of Rojas, failed on the stage. His next venture (1704) was a rifacimento of Avellaneda's *Don Quixote*. The year 1707 was the turning-point in his fortunes. *Don Cesar Ursin*, from Calderon's *Peer esta que estaba*, was played with success at court, and *Crispin rival de son maître* in the city; and more successful than either was the *Diable Boiteux*, the framework, title, and first chapter of which he took from the *Diablo Cojuelo* of Guevara. In 1708 he offered the Théâtre Français two plays; *La Tontine* was accepted, but shelved, and not produced until 1732; *Les Etrangers* was rejected, as rules did not allow one-act pieces before Easter. Le Sage took it back, and altered and expanded it into *Turcaret*; but the financiers it satirised, after an attempt to buy him off with 100,000 livres, organised such an opposition against it that it was saved only by an order from the Dauphin. Le Sage was not a man to submit to caprice. It is told of him that when the Duchesse de Bouillon, at whose house he was to have read *Turcaret*, received him with a haughty reprimand for keeping her waiting, he replied, 'Very well, madame, if I have made you lose an hour I will make you gain two,' and with a bow walked out; and it was no doubt the same spirit of independence that made him go over in 1709 from the Théâtre Français to the opposition Théâtre de la Foire. Unless the *Amants Jaloux* of 1736 be his, he made no attempt after this to return to the regular drama, but continued to supply the Foire stage with slight pieces of the kind it was restricted to, which he published from time to time in the volumes composing the *Théâtre de la Foire*. For these the Persian tales which he helped his friend Pétis de la Croix to put into shape in the *Mille et un Jours* were of great service to him. But the success of the *Diable Boiteux* was too encouraging to allow him to neglect the Spanish. In 1715 *Gil Blas* (vols. I. and II.) came out, followed in 1717-21 by an attempt at an Orlando. In 1724

came the third and, as it seemed, last vol. of *Gil Blas*, and in 1726 a new edition of the *Diable Boiteux*, doubled in bulk by additions of his own and from Santos. In 1732 he gave his *Guzman de Alfarache*, 'purged of superfluous moralities,' and *Robert Chevalier de Beauchêne*, the life of a buccaneer whose widow, he says, furnished the memoirs. In 1734 he took the title of *Estebanillo Gonzalez*, but very little else, from the original Spanish. In 1735 the fourth vol. of *Gil Blas* appeared, and also the *Journée des Parques*; in 1736-38 the *Bachelier de Salamance*, the 'remainder biscuit' of *Gil Blas*; in 1739 his plays, in two vols.; in 1740 *La Valise trouvée*, a volume of letters; and in 1743 the *Mélange Amusant*, a collection of facetiae from his memory or his notebook. That year brought his first sorrow, the death of his eldest son René, otherwise Montménil the comedian. Le Sage had a contempt for actors and their calling, and when his son adopted it he disowned him. But in time, brought round to see him in *Tararac*, he was conquered by his own creation alive in the genius of his son, and the estrangement ended in their being drawn together more closely than ever. The death of his son and his own increasing infirmities, particularly his deafness, made him abandon Paris and literary life, and retreat with his wife and daughter to Boulogne, where his second son, Julien, held a canonry in the cathedral; and there, in the Rue du Château, he died in 1747, in his eightieth year. Of himself, personally, there is very little on record. He was withdrawn from society by his deafness, from which he was a sufferer as early as 1709, and lived a quiet, retired, industrious life, surrounded by his family; and perhaps their devotion and the loving care with which they tended him in his last days are more eloquent than any eulogy of his character and virtues that preacher could pronounce.

Le Sage's reputation as a dramatist and as a novelist rests in each case on one work. The author of *Tararac* might, under favouring circumstances, have done anything in comedy short of dethroning Molière, but as it is he has no claim to a place in the first order of dramatists. But whatever severe critics may say, the author of *Gil Blas* stands in the front rank of the novelists by the common consent of the great mass of readers of all nations. On the other hand there are some who deny originality to one who borrowed ideas, incidents, and tales from others—Espinel, Rojas, Mendoza, Quevedo—as Le Sage did; and some who go still further, and deny that the author of *Gil Blas* was anything more than a translator. The question of what constitutes originality would be out of place here, but the other is simply a question of evidence which may be briefly summed up. It was primarily Voltaire who raised the issue. Le Sage had put him into *Gil Blas* as Don Gabriel Triaquero, and he in return said in his *Sacré de Louis XIV.* that *Gil Blas* was 'entirely taken from *La Vida de lo Escondido Don Marcos d'Obregón*,' showing that he had never seen the book he quoted, and could not read it if he had. Backed by his name, the fignment had a wide circulation, especially in Spain, and the Padre Isla was set on to develop it, which he did in his own peculiar fashion (see *ISLA*). The Comte de Neufchâteau having taken up *Isla* seriously, was replied to by Llorente, who maintained that though *Isla* was in just he had truth on his side. His own theory was that in the Lionne library Le Sage found a MS. novel, called the *Bachelor of Salamance*, written, probably by Solís the historian, in 1655, and that out of this he carved *Gil Blas*, serving up the remainder afterwards under the original title. The argument, in brief, is that

Gil Blas is crowded with details of a kind that Le Sage, who never was in Spain, could have had no knowledge of, and could not have got from books. Of these details, however, a good many need not have had any more recondite source than *Don Quixote*; and for the rest Le Sage would have said that he only wondered at his own moderation, for he could have taken ten times as many from the plays and picaresque novels in the abbé's library, and from books of travellers like Aarssen van Sommelsdyck, Bertaut, and Mme D'Aulnoy. But Llorente points out that over a hundred places, often obscure hamlets that few Spaniards even ever heard of, are named, in general correctly, which is a proof of some exceptional source of information; but sometimes incorrectly, a proof that the source was a MS. not a printed one. But a plain tale will put him down; the names are in old French maps. Of a score picked out as manifest mis-readings from a MS.—Grajal, Rodillas, Luceno, Castil Blazo, &c., all but one are in the map of Spain printed in Paris by Jaillot *circa* 1695, and all the notable ones in that of 1713, just two years before *Gil Blas* appeared. From maps, too, come Le Sage's blunders in topography—e.g. putting Peñador on the road to Salamancea, Alcalá between Madrid and Segovia, Peñafiel between Segovia and Valladolid, Liria 'sur les bords du Guadalaviar.' Finally he urges Le Sage's familiarity with secret history and the private affairs of Olivares, his daughter's marriage (xi. 9), and his adoption of Margarita Spinola's son (xii. 4); and asks how could he have known matters and names not to be found in print, save from a contemporary MS.; which, as before, his mis-readings, Niebles for Niebla, Abiados for Abiados, Valeasar for Valareal, bear witness to? But again the answer is simple. He found 'Niebles' and 'Abiados,' as well as the marriage story in the translated *Anecdotes du ministère d'Olivares* (Paris, 1722), and put the very words of the book into the mouth of Olivares, whose portrait (xi. 2) is word for word from the *Anecdotes*. 'Valeasar' he found in the *Relation de ce qui s'est passé à la disgrâce d'Olivares* (Paris, 1650), from which he took the Count Duke's curious 'confidence' to *Gil Blas*, and, also, sundry names cited by Llorente. One by one, in short, the supports give way, and the MS. theory falls to the ground. Nevertheless, in the absence of rebutting evidence, its plausibility imposed upon some good critics, the author of 'Who Wrote *Gil Blas*?' in *Blackwood* (1844), A. H. Everett, and Ford, among others. All admit, however, that the translator has left the stamp of his nationality indelibly impressed upon the work; the mystery lies in its wealth of detail. Llorente puts the matter in a nutshell when he asks why did Le Sage, if he was the original author, give himself so much needless trouble? Why so particular to name 'Torvalva,' when it would have done just as well to say 'a village near Cuenca?' The answer is that Le Sage was before all things an artist, and knew the value of details in producing the verisimilitude he aimed at. In this respect and many others he was like his great contemporary Defoe. He spared no pains to make his conception a reality to his reader. When he sent *Gil Blas* on a journey he was not content to generalise his road, but looked up the villages he had to pass through on the best map he could find. When he brought him to an inn, he went to the novels and plays for inn furniture and company and conversation. This is the rationale of his borrowings, and it is this, as much as his delightful style, that makes him the prince of raconteurs. He was the first to perceive the capabilities of the picaresque novel, and with the

culinary genius of his nation (by no means confined to artists like him who could make a savoury ragout out of an old boot) he got rid of its crudities, brought out its flavour, and served it up with a *sauce piquante* of his own. In so doing he advanced the novel of real life an important stage, and, to his honour be it said, no abuse of realism can be laid to his charge. In the words of Scott, 'His muse moved with an unpolluted step, even where the path was somewhat miry.'

Lesbos, or MYTILENE, a Turkish island in the Ægean Sea, lies 10 miles from the coast of Asia Minor, north of the Gulf of Smyrna. It is triangular in shape, with two deep inlets on the south-east and south-west, and is for the most part mountainous, reaching 3079 feet in Hagios Elias (Olympus). The soil is fertile and yields good crops of olives, the oil being the chief export. In ancient times wine was a speciality. The climate is delightful. The chief drawback of the island is the earthquakes, which occur pretty frequently. Area, 676 sq. m.; pop. 36,000, mostly Greeks. The ancient capital was Mitylene (on coins Mytilene); the existing town, called Castro, 'a straggling dirty village,' has a population of about 12,000. It stands on a peninsula on the east coast, is defended by a medieval castle, and has a shallow harbour. Other ancient cities were Methymna, Pyrrha, Antissa, and Eresus. The modern town of Agiasso has 7000 to 8000 inhabitants. The island was early colonised by Æolian immigrants. Between 700 and 500 B.C. it was the flourishing home of poets and literary men, as the names of Alceus, Sappho, Terpander, Pittacus, Theophrastus, Theophanes, and others will attest. The Lesbians made themselves masters of considerable territory on the opposite mainland of Asia Minor. But in the 6th century B.C. it was for about sixty years subject to Persia. In 476 it joined the Athenian league, but, revolting in 429, was promptly reduced to obedience again. Then it belonged successively to Macedonia, Pontus, Rome, and Byzantium. From 1355 to 1462 it was owned by a Genoese merchant family, who lost it to Sultan Mohammed II. Of its shores the Turks were defeated by the Venetians in 1690 and 1698, and by the Greeks in 1821. The island has been called Mytilene from the middle ages down to the present time.

See Couze, *Reise auf Lesbos* (1865); C. T. Newton, *Travels and Discoveries in the Levant* (2 vols. 1865); Koldewey, *Die antiken Baureste der Insel Lesbos* (1890); and Tozer, *Islands of the Ægean* (1890).

Lesczynski. See POLAND, LOUIS XV.

Lesghians. See CAVCASUS.

Leslie, a town of Fife, 12 miles SW. of Cupar, and 3 W. of Markinch by a branch-line (1861). It has flax-spinning, bleaching, and paper works. Pop. 3421.

Leslie, Lesly, or LESLEY, THE FAMILY OF, is first found between 1171 and 1199, when Malcolm, son of Bartholf, obtained Lesslyn or Leslie, a wild pastoral parish in Aberdeenshire. His descendants took their surname from their lands.

Earls and Duke of Rothes.—The family was embled in 1457, when George Leslie of Rothes was made Earl of Rothes and Lord Leslie. The fourth earl was father of Norman Leslie, Master of Rothes, the chief actor in the murder of Cardinal Beaton. John, the sixth earl, who died in 1641, distinguished himself as one of the ablest of the Covenanting leaders. His son became Lord Chancellor of Scotland in 1667, and in 1680 was created Duke of Rothes, Marquis of Ballinbreich, Earl of Leslie, &c. These honours became extinct upon his death without male issue in 1681. The earldom

of Rothes went to his elder daughter, in whose family the title has continued.

Earls of Leven.—Before the family left Aberdeenshire it had thrown off branches, some of which still flourish there. The chief, that of Balquhain, gave birth to several men of mark, such as the learned John Leslie, Bishop of Ross (1527-96), the devoted champion of Mary Queen of Scots; Sir Alexander Leslie of Auchintoul, a general in the Muscovite service, who died governor of Smolensko in 1663; and Charles Leslie (q.v.). A still more distinguished man was Alexander Leslie, who rose to be a field-marshal of Sweden under Gustavus Adolphus. Recalled to Scotland in 1639, he took command of the Covenanting army, and in 1641 was made Earl of Leven and Lord Balgony. He died in 1661, and his honours and lands eventually passed to his great-grandson, David Melville, third Earl of Leven and second Earl of Melville. His descendant succeeded as eleventh Earl of Leven and tenth Earl of Melville in 1889.

Lords Lindores.—The second son of the fifth Earl of Rothes was created Lord Lindores in 1600. The title has been dormant since the death of the seventh lord in 1775.

Lords Newark.—David Leslie, fifth son of the first Lord Lindores, served with distinction under Gustavus Adolphus, and, returning to Scotland in 1640, acted as lieutenant-general to the Earl of Leven. He was present at Marston Moor, and surprised and routed Montrose at Philiphaugh. Taken prisoner by Cromwell at Worcester in 1651, he suffered imprisonment in the Tower till the Restoration. He was made Lord Newark in 1661, and died in 1682. The title has been dormant since the death of his great-grandson, the fourth lord, in 1791.

Counts Leslie.—Walter Leslie, a younger son of the House of Balquhain, distinguished himself in the Austrian army, and in 1637 was created a count of the empire, as a reward for his services in the murder of Wallenstein. He died without issue in 1667, when he was succeeded by his nephew, James, a field-marshal in the Austrian service, who died in 1694. The title became extinct in 1844.

Leslie, CHARLES, nonjuring divine, was born at Dublin on the 17th July 1650, studied at Trinity College, Dublin, and, having taken orders in 1680, became chancellor of the cathedral of Connor in 1687. Deprived at the Revolution for declining the oath of allegiance, he retired to England and wrote against Papists, Deists, Socinians, Jews, and Quakers, as well as in support of the nonjuring interests. He went with the Pretender to Italy after 1715, but returned to Ireland in 1721, and died 13th April 1722. His *Short and Easy Method with the Jews* appeared in 1684; his *Short and Easy Method with the Deists* in 1694; he issued a collected edition of his *Theological Works* in two folio volumes in 1721 (new ed. 7 vols. 1832). See a Life by R. J. Leslie (1885).

Leslie, CHARLES ROBERT, genre-painter, was born in London on 19th October 1791, his parents being Americans. He was educated at Philadelphia, to which city his parents took him in 1809. In 1811 he returned to England, and entered as a student in the Royal Academy, West, Fuseli, and Allston exercising the earliest influence over him. The first picture that brought him into notice was 'Sir Roger de Coverley going to Church' (1819). In 1821 'May-day in the Reign of Queen Elizabeth' secured his election as an Associate of the Academy; and 'Sancho Panza and the Duchess,' exhibited in 1824, obtained for him the rank of Academician. Leslie's principal pictures are scenes from the works of Shakespeare,

Cervantes, Le Sage, Moliere, Addison, Swift, Sterne, Fielding, and Smollett. Great power of expression, and a delicate perception of character and of female beauty, are his strongest points. In 1833 he accepted the appointment of professor of Drawing at the military academy of West Point, New York; but gave up the post early in the following year, and returned to England. From 1848 to 1852 he was professor of Painting at the Royal Academy. He died in London on 5th May 1859. His lectures were published in 1855 in the useful *Handbook for Young Painters*; he also wrote an able *Life of Constable* (1843), and began the *Life and Times of Sir Joshua Reynolds*, completed by Tom Taylor. The *Autobiographical Recollections* of Leslie were edited by Tom Taylor (1869).—His son, GEORGE DUNLOP LESLIE, born in London in 1835, whose aim has been 'to paint pictures from the sunny side of English domestic life,' was elected A.R.A. in 1868 and R.A. in 1876. See his *Letters to Marco* (1893) and *River-side Letters* (1896).

Leslie, FRANK, publisher, was born at Ipswich in 1821, his proper name being Henry Carter, and at seventeen was placed in a mercantile house in London. 'Frank Leslie' was the name he adopted in sending in sketches to the *Illustrated London News*, and the success of these determined him to join the staff of that paper. In 1848 he proceeded to the United States, where he assumed the name of Frank Leslie by a legal process, and in 1854 founded the *Gazette of Fashion* and the *New York Journal*. *Frank Leslie's Illustrated Newspaper* was commenced in 1855 (German and Spanish editions later), the *Chimney Corner* in 1865; and afterwards the *Boys' and Girls' Weekly*, the *Lady's Journal*, and a number of other periodicals were published by him. He died 10th January 1880; his widow then assumed his name and carried on his business.

Leslie, SIR JOHN, a celebrated natural philosopher, was born at Largo, Fife, 16th April 1766. He studied at St Andrews and Edinburgh universities, and in 1788 became tutor to two young Americans, with whom he proceeded to Virginia and other parts of America, returning to London in 1790. During the next fifteen years he was variously employed in scientific writing or travelling on the continent with pupils, but all the while engaged in experimental research. The fruits of his labours during this period of his career were a translation of Buffon's *Natural History of Birds* (1793), the invention of a differential thermometer, a hygrometer, and a photometer, and the publication of his important *Experimental Inquiry into the Nature and Propagation of Heat* (1804). For this latter work the Royal Society awarded Leslie the Rumford medal for scientific research. In 1805 he obtained the chair of Mathematics at Edinburgh, in spite of a good deal of opposition from the clergy, who objected to his approval of Hume's theory of causation. He occupied it for fourteen years, but most of his leisure time was occupied in scientific experiments. In 1810 he invented the process of artificial refrigeration, which has since been put to so many practical uses. In 1819 he was transferred to the chair of Natural Philosophy, where his peculiar talents found their proper sphere. During the next few years he wrote numerous articles and published several works on natural philosophy and mathematics; but his chief claim to the gratitude of the scientific world lies in his useful inventions, such as the pyroscope, atmometer, athriroscope, and the prominence which he gave to experimental illustration in his university lectures. In 1832 he was created a Knight of the Guelphic Order; on 2d November of the same year he died, at his

estate of Coates, in Fife, near his birthplace. See *Memoir* by Macvey Napier (1838).

Leslie, THOMAS EDWARD CLIFFE, political economist, was born in County Down, Ireland, in 1827, and educated at Trinity College, Dublin. He qualified for the bar, but in 1853 was appointed to the chair of Economics and Jurisprudence at Belfast. In that city he died on 27th January 1882. His writings, mostly fragmentary in character, were collected in two books entitled *The Land Systems* (1870), containing studies on the land question in Ireland, Belgium, and France, and *Essays in Political and Moral Philosophy* (1879), which treat principally of the gold question and economic method. Leslie was a strenuous advocate for the study of economic problems in the light of the historic method, instead of the purely analytic method of Ricardo. He introduced the works of continental economists, such as Roscher and Laveleye, to the notice of English students.

Lespinasse, CLAIRE FRANCOISE, OF JULIE JEANNE ELEONORE, was born 9th Nov. 1732, at Lyons, an illegitimate daughter of the Countess d'Albon. At first a teacher, she became in 1754 a companion to Madame du Deffand, whose friends, especially D'Alembert, she quickly attached to herself. After the inevitable rupture that followed, she was enabled by the bounty of her friends to maintain a modest salon of her own. The charm she exercised was in no wise due to beauty, for she was plain in face, and, moreover, disfigured by smallpox; yet conversation was brighter and more harmonious, and wit more brilliant in her circle than anywhere else in Paris. Unfortunately for her peace she had a heart sensitive to love, and the passion she was capable of at forty for the young Spaniard, the Marquis de Mora, and two years later for M. de Guilbert, cost her the deepest pangs, when the first died and the second was separated by marriage. The famous D'Alembert had long admired and loved her, but her affection for the philosopher never cost her tears. She died at Paris, 23d May 1776. Many of her letters to her two lovers have been published, and these are aglow with fire and passion. Indeed, in their first editor's metaphor, her phrases burn the paper on which they are written.

The famous *Letters* were published in two volumes in 1809. Later editions are by J. Janin (1847) and Sambert (1877). M. Charles Henry's *Letters inédites* (1887) were mostly addressed to Condorcet. The editor's introduction is much too high-pitched. A juster judgment will be found in vol. ii. of Sainte-Beuve's *Causeries de Launois*.

Lesseps, FERDINAND, VICOMTE DE, engineer, was born at Versailles, November 19, 1805. Educated for the diplomatic profession, he filled successive appointments at Lisbon, Cairo, Barcelona, and Madrid. In 1854 he conceived his great scheme for cutting the Suez Canal, and in January 1856 he received a letter of concession from the Viceroy of Egypt. Robert Stephenson and other English engineers questioned the practicability of the scheme, but De Lesseps overcame all obstacles. A company was formed, and the works were begun in 1860. The great undertaking was completed (see CANAL, and SUEZ) in August 1869, the canal being formally opened on 17th November following. The successful engineer was created K.C.S.I. by Queen Victoria, and received the honorary freedom of the city of London in 1870. The Paris Societe de Géographie awarded him 10,000 francs; he was appointed a Grand Cross of the Legion of Honour; and after the publication of his *History of the Canal* he was awarded 5000 francs by the French Academy. In 1873 the Paris Academy of Sciences elected him a free member, and in 1881 he was elected president of the French Geographical Society. In 1883 he sought to conclude an

arrangement with the British government for a second Suez Canal. Meanwhile, work had begun on his stupendous scheme for a Panama Canal (see CANAL, and PANAMA), a scheme destined to issue in disaster and disgrace. For in 1892-93 the management was charged with breach of trust, and five directors were condemned—Lesseps, now a broken old man, to five years' imprisonment and a fine, as was also his son Charles. The sentence was ultimately quashed; but he fell into dotage, and died 7th December 1894. He wrote *Documents pour servir à l'histoire du Canal de Suez* (4 vols. 1875-79; trans. 1876), and *Souvenirs de Quarante Ans* (1887; trans. 1887). See books by Ferrier (1887), G. B. Smith (2d. ed. 1895), Bridier (1899).

Lessing, GOTTHOLD EPHRAIM, reformer of German literature, was born, the son of the pastor of Kamenz, in Saxony, on 22d January 1729. From the school of St Afra, at Meissen, where he had spent five years, he entered in 1746 as a theological student at Leipzig. But, instead of studying theology, he made haste to acquire a knowledge of men and of the world, to polish his manners, to learn bodily and social accomplishments, and to improve his taste, and developed that strong, manly independence which was always one of the most striking traits in his character. Moreover, he cultivated a love for the stage, and began to write plays, mostly comedies, in the French style. All this sorely grieved his strictly orthodox parents. And yet, both at Meissen and at Leipzig, Lessing manifested an ardent thirst for knowledge and truth; he had great intellectual parts, and read hard. But his mode of life at the university ran him into debt—a state that was more or less chronic to him throughout his life; then in 1748 the theatre was closed; and he suffered from an innate restlessness that never let him abide long in one place. Accordingly, braving his father's serious displeasure, he quitted Leipzig, having resolved to earn a living by his pen, notwithstanding that the calling of author was held in little or no repute. After a few months' stay in Wittenberg, he travelled to Berlin to join Mylius, a clever man, but branded as a freethinker by the orthodox. Along with him Lessing published *Beitrag zur Historie des Theaters* (1750), and independently wrote plays, translated, did literary hack-work; but his chief stay was the *Vossische Zeitung*, to which he contributed criticisms. He soon felt, however, that he himself stood in need of greater culture, and in the end of 1751 he withdrew to Wittenberg to study at leisure; at the same time he pleased his father by taking his master's degree. The result of his toil in the Wittenberg library was a series of *Vindications* (1751) of unjustly maligned or forgotten writers, such as Cardan, Lemnius, &c., in which he gave bold utterance to his strong love of justice and his scorn of narrow intolerance. Later, in *Ein Vademecum für Herrn S. G. Lange* (1754) he displayed as unrelenting an hostility to pretensions and self-satisfied ignorance. Returning to Berlin after a year's absence, he resumed his former occupations. At this time too he became intimate with Moses Mendelssohn, Nicolai, and Ramler. He also published four volumes of his collected writings, and, along with Mendelssohn, an essay on *Pope, ein Metaphysiker* (1755). But he still strove to make the theatre an engine of popular culture: he wrote the tragedy *Miss Sara Sampson* (1755), in which he revolted against French theatrical traditions in favour of English models. For *dramatis personæ* he took people of middle-class life, and so carried on the movement begun by Lillo, the dramatist, and Richardson, the novelist, in England, and by Diderot in France. The success of this work tempted Lessing back to the theatre, reopened, at Leipzig; but he only stayed

there a short time. In May 1756 he set off, as companion to a young gentleman (Winkler) of that city, on an extended tour; but they had only reached Holland when they were hastily summoned home by the outbreak of the Seven Years' War. Lessing then remained some time in Leipzig, to be near his friend the poet Ewald von Kleist.

In 1758 he was once more in Berlin, assisting Mendelssohn and Nicolai to bring out a new critical journal, *Litteraturbriefe*. In the work he did for this publication Lessing takes a distinctively higher place: he refuses any longer to submit to the degrading dictatorship of French literary taste, combats the inflated pedantry of the Gottsched school, and extols Shakespeare above Corneille as the highest type of dramatic writer. In these letters he displays most of the admirable qualities of his mature style: his insight is penetrating and sure; his manner vivacious, often ironical or satirical; his intellect is strong and logical, yet supple, and works easily; and his language is clear, forcible, and elegant. He always possessed the power of making dry subjects interesting. From November 1760 to the spring of 1765 Lessing enlarged his knowledge of men by acting as secretary to General von Tauentzien, governor of Breslau. During these years he wrote two of his greatest works, *Laocoon* (1766) and *Minna von Barnhelm* (1767). The former is a critical treatise defining the limits of poetry and the plastic arts. It affords an admirable illustration of Lessing's critical procedure. He plunges at once into the midst of the argument, takes up various views one after another, examines them, contrasts them, searches and sifts them from all sides, and exhausts upon them the resources of the dialectical method; then out of what survives this intellectual conflict he constructs his final conclusions. Yet the movement of thought is simple, natural, and logical; we are led to discover the truth by the same paths by which the author arrived at it originally. His essays on the *Fable* (1759) and the *Epigram* (1771) are both admirable instances of the same method. The comely *Minna von Barnhelm* shows no trace of imitation of foreign models: it is the first national comedy of the Germans on the grand scale, and is a great advance on Lessing's early dramatic efforts. After Frederick the Great had refused to nominate him keeper of the Royal Library at Berlin, Lessing was glad to accept the post of critic to the new national theatre at Hamburg in 1767. Out of these new duties grew the celebrated *Hamburgische Dramaturgie* (1769), in which he overthrew finally the dictatorship of the French drama and worked out the thoughts that had for many years been ripening in his mind. This theatre too soon failed, and Lessing was again left without fixed occupation. Yet he was never long idle, especially so long as there was error to combat, and ignorance and pedantic vanity to expose. For, though a scholar himself, he always regarded learning not as an end in itself, but as a means; he always accounted truth superior to mere knowledge. He was naturally fond of disputation, and so we soon find him in the thick of another controversy, this time with Klotz, a young Halle professor. On this occasion he had a double purpose to serve—to defend his *Laocoon* and to expose the pretensions of the men who set themselves up as leaders of German scholarship. The chief fruits of this controversy from Lessing's pen were *Brüder antiquarischen Inhalts* (1769) and *Wie die Alten den Tod gebildet* (1769).

In October 1769 the Duke of Brunswick offered Lessing the librarianship of the Wolfenbüttel library; he accepted it and entered upon his duties in the following May. Here at last he settled for good, and in 1776 married Eva König, the widow of

a Hamburg merchant, but lost her after little more than a year of happy married life. He at once began to publish some of the less-known treasures of the library in a series of volumes entitled *Zur Geschichte und Literatur* (6 vols. 1773-81). But in 1772 he wrote the tragedy *Emilia Galotti*, which in spite of grave faults, notably the absence of dramatic necessity for the catastrophe, is one of the greatest tragedies in German literature, certainly the greatest Lessing wrote. Shortly before his marriage he carried out a long-cherished desire, by spending eight months in Italy, though as companion to the hereditary Duke of Brunswick. His last years were occupied with theological controversies. In 1777 he published the famous *Wolfenbüttelsche Fragmente*, a rationalist attack on Christianity from the pen of Reimarus (q.v.). This book, which was almost universally attributed to Lessing, provoked a storm of replies from orthodox Lutherans. The best of Lessing's counter-attacks were the polemical *Anti-Görze* (1778), directed against his chief assailant, and the fine dramatic poem, *Nathan der Weise* (1779), one of the noblest pleas for tolerant humanity ever penned. This last was supplemented by *Die Erziehung des Menschengeschlechts* (1780), which is extremely rich in suggestive thought. Lessing's last work was *Ernst und Falk* (1778-80), five dialogues on freemasonry. He died 15th February 1781. The best edition of his *Sammeltliche Schriften* is Lachmann's, reissued by München in 1886 *seq.* His chief works have been often translated into English. See Kunt's *Lessing et l'Antiquité* (1899); Lives by Danzel and Gubrauer (2d ed. 1889), Erich Schmidt (2d ed. 1889), Sime (1877), Helen Zimmern (1878), and Rolleston (1889)—the last three in English.

Lesson (Lat. *lectio*), a reading, especially a portion of Scripture appointed to be read, as in the Common Prayer-book. The oldest Latin lectionary—a service-book, either containing the lessons for the year in full, or noting their beginning and end—was called the *Comes* ('companion'), and dates from the 5th century. The Roman Lectionary was remodelled in the 8th century. The changes in the Anglican calendar of lessons were sanctioned by act of parliament in 1871. Formerly the lessons consisted invariably of full chapters—a rule that was sometimes embarrassing, as in the case of Acts xxi.—but in the revised lectionary they are frequently shortened and differently arranged; also, nearly all the lessons from the Apocrypha have been left out.

L'Étrange, SIR ROGER, a busy royalist pamphleteer under Charles II., was born at Hunstanton in Norfolk in 1616. He narrowly escaped hanging as a spy for a plot to seize Lynn in 1644, and was instead imprisoned in Newgate, whence he escaped after four years. Pardonned by Cromwell in 1653 through personal entreaty, he lived quietly till the Restoration made him licensor of the press. He carried out his functions rigorously, but it should be remembered that such were his instructions. He fought in all the quarrels of the time with a shower of pamphlets, vigorous, and at least not coarser than those of his antagonists; and he holds a place in the history of journalism by his successive papers, *The Public Intelligencer*, *The London Gazette*, and *The Observer*. In the intervals of controversy he showed that he was not without a taste for better things by translating *Æsop's Fables*, *Seneca's Morals*, *Cicero's Offices*, the *Colloquies* of Erasmus, *Quevedo's Visions*, and *Josephus*. He died in 1704.

Le Sueur, EUSTACHE, painter, was born in Paris in 1617, and died there in 1655. The Louvre possesses 36 religious pictures by him, and 13 mythological, the former including his great series

of 20 paintings illustrating the life of St Bruno (1645-48), and his 'Preaching of St Paul' (1649).

Lethe, in Greek mythology, the stream of forgetfulness in the lower world, from which souls drank before passing into the Elysian Fields, that they might lose all recollection of earthly sorrows.

Lethington. See MAITLAND.

Leto. See APOLLO.

Letter of Marque (Fr. *lettre de marque*, 'a commission to plunder'; cf. Littré, iii. 456), the commission authorising a privateer to make war upon, or seize the property of, another nation. Letters of marque were abolished among European nations at the treaty of Paris in 1856. See PRIVATEER.

Letters are conventional marks or visible signs of the elemental sounds of spoken language. The earliest symbols of sounds represented syllables rather than simple sounds, and it was only gradually that syllables were reduced to their ultimate elements, all alphabets yet bearing marks of the syllabary origin and displaying various imperfections of excess and defect. The distinction between vowels (*φωνήεντα* and *φωνήεντα*) and consonants (*ἄφωνα ᾠσώμενα*) is as old as Plato's *Cratylus*, but the earlier methods of classification, which offered no definite line of demarcation, have given place to a more scientific method and more precise terminology. A consonant is the sound or noise resulting when the breath is closely squeezed or stopped at some part of the mouth or breath passage. This passage has two outlets; one at the lips, the other at the nose. In the case of some consonants the passage is closed at a given point—e.g. at the lips in *p, b*; at the teeth in *t, d*; at the palate in *k, g*; while the nose-passage is closed by the bottom (*uvula*) of the soft palate. In the case of other consonants the passage is not closed but only narrowed, and the breath sounds against the narrow walls, as in *f, s, ch*, &c. The nose channel is left open in pronouncing *n, m*. In the case of vowels the breath is not checked or closely narrowed at a given point, but passes freely through the mouth-passage, and they may be classified according to the place of their articulation in this passage owing to the horizontal or vertical movements of the tongue. They may also be distinguished as open (or wide) and shut (or narrow); in the latter there is more convexity of the tongue and a sense of effort in pronunciation. Consonants, again, are classified according to the point in the mouth-passage at which they are articulated. Furthest back we have the *guttural* sounds, with articulation of the tongue and the soft palate (*velum*), hence called the Velar Gutturals, as the sounds of *k* and *g* before the vowel sounds *a* and *o, ch* in German *wah*, and *ng* in *sing*. Further forward we have the Palatals, which result from the contact of the tongue and hard palate, as *k* and *g* before *e* and *i*. Next come the Dentals, where the tongue, teeth, and front of the palate are the instruments of articulation—e.g. *t, th, d, sh, c*. The Labials, or lip-sounds, are those which are formed either by both the lips or by the under lip and upper teeth, *p, b, m, f, v*.

Again, consonants may also be classified according to the form of their articulation. When there is a complete check or closure of the mouth passage at the point of articulation, consonants are called Mutes or Stopped or Explosives, as *k, g, t, d, p, b*. The ancient grammarians divided mutes into *Tenuis* and *Medar*, the former including *k, t, p*, the latter *g, d, b*. When the mouth-passage is narrowed but not completely closed at the point of articulation, we have the Open or Fricative consonants, such as *r, s, f, z, c*, the last four of which are also called Spirants. When the passage is stopped in the

middle but kept open at the sides, we have a *Divided* sound, such as *l*. When the nose-passage is left open we have the *Nasals* *m* and *n*. *N* takes its character from the nature of the neighbouring sounds—e.g. it is guttural in *sink*, but dental in *let*.

Again, consonants may be divided into Voiced and Voiceless. The voiced or soft consonants are pronounced with a vibration of the vocal chords. To this class belong the Nasals *n, m*; the Liquids *l* and *r*; the Media *g, d, b*; the Aspirated Media *gh, dh, bh*; and the Spirants *z, j, v*. The Voiceless or Sord consonants are the Tenues *p, t, k, q*, the Aspirated tenues *kh, th, ph*, and the Spirants *s, f*.

There are some sounds which can play the part of either consonants or vowels, as the Semi-vowels *i* and *u*. In the same way, *m, n, r, l* between vowels are purely consonantal, but before or after consonants they can be vocalised or made *sonant*. Besides all these different sounds we have the introductory *glides*, represented by the smooth and rough breathings.

Such is the variety and complexity of the different sounds which are attempted to be represented in the letters of alphabets. These, however, merely satisfy roughly practical needs, and in no case represent all the sounds actually employed in any language. Accentuation, which is an important element of speech, is rarely denoted, and still more rarely is quantity. The alphabetic symbols remain comparatively unchanged, while the sounds they represent are constantly changing. Hence the literary spelling often corresponds but indifferently with the actual sounds of the words, and in English especially this has grown into so heavy an additional burden on the memories of learners that many scholars have been led to advocate the adoption of a scientific *phonetic* system of spelling. Thus, in English there are at least forty-three easily distinguished sounds, while the written alphabet has only twenty-six letters or symbols to represent these. Again, our alphabet is redundant, containing three superfluous letters, *c, y, x*, so that there are actually but twenty-three letters wherewith to represent forty-three sounds!

Many persons amongst ourselves are unable to pronounce certain letters, as *l* and *r*; others change *r* or *l* to *d*, and we observe that children for some time habitually substitute dentals for gutturals, as *bat* for *cat*, *tess* for *kess*. This is quite distinct from phonetic diversification which follows certain definite laws, the observation of which formed the basis of scientific etymology. We find that some languages lack certain sounds which to us seem indispensable. Thus, the Mohawks and Hurons employ no labials; the Society Islanders are destitute of gutturals (the name of Captain Cook became *Tate*), and the Australian dialects of *s*, as are also several of the Polynesian languages, where its place is taken by *h* (cf. Lat. *sal* and Gr. *hals*). Again, *d* is never used in Chinese, Mexican, or Peruvian; *u* is absent in the language of the Hurons; and even in so perfect a language as Sanskrit we have no *f*, no soft sibilants, no short *e* and *o*. Greek has no *y*, no *w*, no soft sibilants; Latin has no soft sibilants, no native *θ, φ, χ*; English is deficient in guttural breathings like the German *ach* and *ich*, although these are plentiful enough in Scotland. High German has no *w* like the English *w* in wind, no *th, dh, ch, j*. While Sanskrit has no *f*, Arabic has no *p*. The letter *f* is absent in Finnish (despite the name—given it by its neighbours), Lithuanian, Tamil, Mongolian, and Burmese. No Chinaman ever pronounces *r*, Christ being rendered *Ki li xse tu*. It is also absent in the language of the Hurons, Mexicans, and Kaffirs. Max Müller gives the following enumeration of the consonants in a few alphabets: Hindustani has 48 consonants, of which

13 are classical Sanskrit aspirates, nasals, and sibilants, and 14 Arabic letters. Sanskrit has 37 consonants (or with the Vedic *l* and *lh*, 39); Turkish, 32 (of which only 25 are really Turkish); and Persian, 31 (of which 22 are really Persian, the rest Arabic). Arabic has 28; the Kafir (*Zulu*), 26, besides the clicks. Hebrew has 23; English, 20; Greek, 17 (3 compound); Latin, 17 (1 compound); Mongolian, 17 or 18; Finnish, 11; Polynesian, 10 native consonantal sounds; some Australian languages, 8; of the Melanesian languages the poorest, the Dnauru, has 12, others 13, 14, and more. Again, some races find exceeding difficulty in distinguishing some of our sounds. Thus, the Sandwich Islanders habitually confuse *k* and *t*, and we find the same word written by Protestant missionaries with *k*, by French missionaries with *t*. Even in Canada the lower classes say *netkier* and *moikie* for *netier* and *moitie*. And even so respected a lexicographer as Noah Webster actually says in the Introduction to his Dictionary that in English the letters *cl* are pronounced as if written *tl*, and *gl* as if *dl*.

The foregoing is mainly taken from the following: J. E. King and C. Cookson's admirable *Principles of Sound and Inflection* (1888), their *Introduction to the Comparative Grammar of Greek and Latin* (1890), and Max Müller's *Lectures on the Science of Language* (2d series, lect. iv, 1864). See also the articles in the present work on ALPHABET, GRAMMAR, GRIMM'S LAW, PHONETICS, SPELLING, and on each of the letters of the alphabet.

Letters forms one of the most delightful branches of literature, and one moreover in which English possesses abundance of the finest examples. Most biographies that are now written contain the letters of the hero, and these usually open up his heart to the reader far better than pages of description of his qualities; while they also supply, by conscious or unconscious self-revelation, something of the peculiar interest that belongs to autobiography. But here may be remembered the warning words of Dr Johnson written *a propos* of Pope: 'There is no transaction which offers stronger temptations to fallacy and sophistication than epistolary intercourse. In the eagerness of conversation the first emotions of the mind often burst out before they are considered; in the tumult of business interest and passion have their genuine effect; but a friendly letter is a calm and deliberate performance in the cool of leisure, in the stillness of solitude, and surely no man sits down to depreciate by design his own character.' It is unhappily the fact that the conditions of modern life are generally unfavourable to the production of letters of the best class, which are the fruit of calm and ample leisure no less than of sympathy. The railway, the penny post, the telegram, and the postcard have combined to destroy letter-writing as a pursuit and an art. There is nowadays scarcely such a thing as *correspondence* in its good old sense—what Southey calls 'perhaps the greatest gratification which the progress of civilisation has given us'; letters are only written when necessary, and consequently are too often completely impersonal and entirely uninteresting. Hence familiar letters, intimate and easy in tone, fluent and seemingly careless in style, have almost disappeared, and in their stead we have only the ephemeral, bald, disjointed, essentially unliterary, and it may even be ungrammatical productions, which, the moment their immediate purpose is served, are straightway consigned to the extinction for which they are fitted, and to which end indeed they were designed.

Of letters Bacon says 'such as are written from wise men are of all the words of man, in my judgment, the best; for they are more natural than orations and public speeches, and more advised than conferences or present speeches. So again letters of state from such as manage them, or are

privity to them, are of all others the best instructions for history, and to a diligent reader the best histories in themselves.' Undoubtedly this is true, and the letters of such men as Cassiodorus, Cromwell, Marlborough, Nelson, Washington, and Wellington, as well as such vast collections as the Cecil Correspondence, and the like, will remain documents of the first importance to the historian; while the theologian will never cease to count the epistles of Gregory Nazianzen, Basil, Chrysostom, Ambrose, Augustine, and Jerome among the richest sources available for a close study of the development of dogma and the movement of ecclesiastical history. Again, such collections as Pascal's *Provincial Letters*, Swift's *Draper's Letters*, and the *Letters of Junius* only belong in a secondary sense to this department of literature, and lack the peculiar personal charm that belongs to such letters as those of Cicero, Horace Walpole, or Madame de Sevigne.

Of all the favourite letter-writers of the world Cicero is both the earliest and remains almost the greatest. More than 800 of his letters are extant; and all are natural, sincere, outspoken. The very frankness of his vanity and an almost feminine desire to please give a singular pleasure to his reader; and his own phrase in one of his letters—'fit enim nescio quid ut quasi coram adesse videar cum scribo aliquid ad te'—reveals in a single sentence the secret of his perennial charm. And he was singularly happy in a correspondent so sympathetic and intelligent as Atticus, to whom alone he sent as many as 400 letters, for Montaigne tells us how the want of such a judicious and indulgent friend to whom to address kept him from adopting the epistolary method for publishing his whimsies which otherwise he would have preferred. The only other important Latin letter-writers are Seneca and Pliny, but the one offends by prosy and tedious moralising, the other by a prolix and grandiose manner that soon proves tiresome.

The Paston letters, over 1000 in number, are lucid and unaltered and give us our best insight into the inner domestic life of the 15th century; but the earliest English letter-writer of high rank is James Howell, whose *Familiar Letters* shared with Montaigne the honour of being one of Thackeray's two 'bed-side books.' Howell says 'familiar letters may be called the *larum bells of love*,' and elsewhere admirably describes his own compositions in the sentence—'that's a true familiar letter which expresseth one's mind, as if he were discoursing with the party to whom he writes, in succinct and short terms.' Nowhere can we find more shrewdness, wit, wisdom, and keenness of observation, all combined with heartiness and sincerity; none knows better how to brighten his page with a merry quip or a lively story.

But our greatest letter-writers remain but three, or at most four; Gray, Horace Walpole, Cowper, and Charles Lamb. Gray's work is fastidious, precise perfect, but never laboured, and always completely sincere. It suggests the finished scholar unbending to please a friend, and the perfection is a consummation that came of itself, unstudied and unsought. Pope and Bolingbroke wrote for fame—their writing ever suggests an intellectual exercise, and even the letters between Pope and Swift are never entirely free from consciousness; but Gray wrote for love, and his letters, with those of Cowper and Charles Lamb, stand by themselves. Horace Walpole said of himself that he lived 'a life of letter-writing,' and he remains pre-eminent alike in the number and the remarkable felicity of his letters. He is by turns gay, good-humoured, piquant, keen, sarcastic, but is always clever and often even genial, although not seldom the reader detects the presence of effort and affectation. Still, all defects apart, judged in respect of both quantity and quality, and

of the extraordinary range of subjects handled, he remains without a rival the prince of English letter-writers.

Lady Mary Wortley Montagu's letters are unusually lively, clever, and amusing, but are marred by a constitutional indelicacy of tone as well as a vanity and a consciousness of skill that will not hide. Chesterfield's letters to his natural son show great shrewdness and powers of observation in a finished if over-elaborated style, but reveal a moral meanness of view that stamps the finished man of the world as but a sorry gentleman. The letters to his godson, written in later life, and first published by the late Lord Carnarvon in 1889, show a higher tone, but are poor performances if judged from the point of view of letters written to a child. The letters of Dorothy Osborne to Sir William Temple are delightful beyond most; those of Sir William himself, so long admired as models of serene and stately English, have ceased to interest the modern reader. But Lady Rachel Russell's letters, the apologetic scraps written by Steele to his wife Prue, and Swift's letters to Stella preserve a charm that defies the touch of time. Other 18th-century letters of interest are those of Mrs Delaney, covering half a century, Fanny Burney, Miss Berry, one of Walpole's later correspondents, and Hannah More. Dr Johnson's letters are always admirably vigorous and direct, and one at least is among the most memorable things in English literature; but he never put his strength into this form, and indeed disliked to write freely in letters from the after-use that might be made of them. Jane Austen's letters are not characteristic of her unique genius; Burns's are artificial and disappointing; Sterne's mawkish and unreal; Goldsmith's good, but few and unimportant. But the century closes well with the inimitable masterpieces of Cowper, throughout full of tenderness, grace, vivacity, wit, and sense.

Of 19th-century letters the characteristic examples of Charles Lamb stand first. Even the slightest show the peculiar charm of his touch, and all are stamped with the sign-manual of genius. Scott's letters are hearty, genial, and honest; Byron's clever, trenchant, and somewhat unreal. There are many good letters of Southey, Crabbe, Sydney Smith, Leigh Hunt, De Quincey, Lockhart, Macaulay, Dr Arnold, Hood, Washington Irving, Emerson, Carlyle, Lady Duff Gordon, and Ruskin. Thirlwall's *Letters to a Friend*, and Thackeray's *Letters*, published in 1887, are unusually good collections. Shelley is an author not yet judged sensibly by either set of readers, but it is enough to say of his letters that they are neither so much above his poetry as Matthew Arnold would place them nor as far below it as they appear to Mr Swinburne. The letters of Mary Godwin to Inlay, written towards the close of the 18th century, are deeply interesting; those of Keats to Fanny Brawne do injustice to the memory of a sovereign poet, and should never have been printed. But indeed the love-letter is almost always a flower that will not bear being plucked from the stalk on which it grew, and those that are nowadays too often read aloud in breach-of-promise cases are almost always as unreal as the short-lived passion that inspired them. Of later 19th-century English letters none stand out greater than those of Mrs Carlyle and Edward Fitzgerald, which have indeed already been lifted into the rank of the English classics in this kind.

Of German letter-writers it may be enough to name Schiller, Goethe, and Humboldt; of French, Voiture, Madame de Maintenon, Madame du Defand, Sainte Beuve, George Sand, Merimee, and the unapproachable name of Madame de Sevigne. The sovereign quality of this great letter-writer is her naturalness and goodness of heart, combined with

an unmatched facility of sympathetically realising the emotional experiences of others, and of adding reality and life to everything she touched. None ever possessed in richer measure the woman's gift of that warmer interest in the smaller commerce of life, and that aptitude for treating social or public matters from the private and personal point of view which give half their charm to the letters of women. She tells her daughter, to whom she wrote with overflowing affection for twenty-five years, that she lets her pen 'run on and take its own way. . . . I commence always without knowing how far I shall go; I know not whether my letter will be long or short.' Horace Walpole says of her, 'She has the art of making you acquainted with all her acquaintance, and attaches you even to the spots she inhabited.' There is no writer whose inherent goodness has been repaid with a warmer love than Madame de Sévigné, or whose supremacy upon an intellectual throne is less likely ever to be shaken.

The English reader will find the form of the ancient Roman letter in the example preserved in Acts xxiii. The modern English letter differs from the older only in being somewhat less ceremonious and less varied in form. Thus, 'sir' alone was once nearly universal as the form of address, but is now considered cold. Again, 'honoured sir' and 'respected sir' have almost disappeared, and unhappily also such beautiful forms as 'heart' and 'sweet-heart.' Howell often ends with 'yours inviolably,' 'yours entirely,' 'yours in no vulgar way of friendship,' Horace Walpole says 'yours very much,' 'yours most cordially,' and once, to Hannah More in 1789, 'yours more and more.' Puritan writers often used forms strange to modern ears, such as 'yours in the bowels of Christ.' Baxter in his *certain epistolare* with Peter Heylin delightfully subscribes himself 'yours in so far as you are for the truth.' In earlier times it was customary to add on the outside directions to the bearer, as 'Haste, ha-te,' and in official letters even such pointed provocatives of speed as 'Ride, ride, for your life.' Underlining is a detestable practice, equivalent to a confession of weakness in being forced to borrow strength from adventitious aid, and crossing is a device happily practised by but few men at least, although it had its use in days of dear postage. Many, however, indulge in a *postscript*, without which it is said no lady's letter is complete.

The earliest guide to letter-writing extant is Angel Day's *English Secretary* (1599). Another, by Gervase Markham, is entitled *Concited Letters; or a most Excellent Bundle of New Wit* (1618). Forms of letters, with much else, were also given in the popular *Academy of Compliments* (1671). Of such books there is now great abundance; but, while occasionally helpful, they are by no means an unmixt blessing, being no doubt responsible for many ridiculous phrases that are in too common use. But to them the world owes the masterpieces of Richardson, who, in his labours upon a guide to correspondence, discovered that he could write novels that could melt the hearts of the women.

See William Roberts, *History of Letter-writing, from the Earliest Period to the Fifth Century* (1843); Charles Knight, *Half-hours with the best Letter-writers and Autobiographers* (two series, 1867-68); George Seton, *Gossip about Letters and Letter-writers* (1870); W. Baptiste Seaman, *Four Centuries of English Letters* (1880); and Robert Cochrane, *The British Letter-writers* (1882). The two last books are excellent collections, full, yet admirably selected. There is a collection of *Love Letters of Famous Men and Women of Past and Present Centuries* (2 vols., 1888) by Mr. Merydew. The copyright of letters remains with the writer (see COPYRIGHT).

Letters. For Letters Patent, see PATENTS; for Letter of Attorney, see ATTORNEY.

Letter-wood. See BREAD-NUT.

Lettres de Cachet, the name given to the famous warrants of imprisonment issued by the kings of France before the Revolution. All royal letters (*lettres royales*) were either *lettres patentes* or *lettres de cachet*. The former were open, signed by the king, and countersigned by a minister, and had the great seal of state appended. Of

this kind were all ordinances, grants of privilege, &c. But these checks on arbitrary power did not exist with regard to *lettres de cachet*, also called *lettres closes*, or sealed letters, which were folded up and sealed with the king's little seal (*cachet*), and by which the royal pleasure was made known to individuals or to corporations, and the administration of justice was often interfered with. The use of *lettres de cachet* became much more frequent after the accession of Louis XIV. than it had been before, and it was very common for persons to be arrested upon such warrant, and clapped into the Bastille (q.v.) or some other state-prison; where some of them remained for a very long time, and some for life, either because it was so intended, or, in other cases, because they were forgotten. It was not always for political reasons that *lettres de cachet* were obtained: sometimes private persons got troublesome members of their families brought to reason in this way. The lieutenant general of the police kept forms of *lettres de cachet* ready, in which it was only necessary to insert the name of the individual to be arrested. Sometimes an arrestment on *lettres de cachet* was a resource to shield criminals from justice.

Letts, a branch of the Lithuanian race, who in manners, customs, and mode of living do not differ much from the Lithuanians proper. They live in south Livonia, in Courland, and Vitelsk, and in the north of Kovno in Russia, and number about 1,200,000 persons. Early converted to Christianity by the Teutonic Knights, they are now mostly Lutherans, though some 50,000 have been won over to the Greek Church. All are peasant agriculturists: since the abolition of serfdom they have made remarkable progress, both socially and intellectually. Their language is not so archaic as Lithuanian; but they possess valuable treasures of popular poetry, proverbs, riddles, &c. See Umann, *Lettsche Volkslieder* (1874), and Bielenstein, *Ein Tausend Lettsche Rätsel* (1881); also Von Darneth, *Die Letten unter den Deutschen* (2d ed., 1887), and C. F. Watson, *Ueber den Lettschen Volksstamm* (1822).

Lettuces (*Lactuca*), a genus of plants belonging to the natural order Compositae, sub-order Cichoraceae. The Garden Lettuce (*L. sativa*) is supposed to be a native of the East Indies, but is not known to exist anywhere in a wild state, and from remote antiquity has been cultivated in Europe as an esculent, and particularly as a salad. It has a leafy stem, oblong leaves, a spreading, flat-topped panicle, somewhat resembling a corymb, with yellow flowers, and a fruit without margin. It is now generally cultivated in all parts of the world where the climate admits of it; and there are many varieties, all of which may, however, be regarded as sub-varieties of the Cos Lettuce and the Cabbage Lettuce, the former having the leaves more oblong and upright, requiring to be tied together for blanching the latter with rounder leaves, which spread out nearer the ground, and afterwards *ball* or roll together into a head like a small cabbage. The lettuce is easy of digestion, gently laxative, and moderately nutritious. The white and somewhat narcotic milky juice of this plant is inspissated, and used under the name of *Lactucarium* or *Thalassar* as an anodyne, sedative, opiate medicine. The best and most useful kind of this juice is obtained by making incisions in the flowering stems, and allowing the juice which flows to dry upon them. In mild winters they may be kept ready for planting out in spring. The other species of this genus exhibit nothing of the bland quality of the garden lettuce. The Strong-seeded Lettuce (*L. virosa*) is distinguished by the prickly keel of the leaves, and

by a black, smooth seed, with a rather broad margin. It is found in some parts of Britain. *Lactucarium* is prepared from its fresh gathered leaves in the flowering season. The leaves have a strong and nauseous, narcotic and opium-like smell. *L. perennis* adorns with beautiful blue flowers the stony declivities of mountains and clefts of rocks in some parts of Germany, as in the Harz, &c., but is not a native of Britain, which, however, possesses one or two other species in qualities resembling *L. virosa*.

Leucadia. See LEUKAS.

Leuchtenberg. See BEAUFARNAIS.

Leucine, or AMIDO-CAPROIC ACID, a product of the decomposition of albuminous materials occurring in many of the juices of the animal body; formula $C_8H_{11}O_2NH_2$. A substance isomeric, but not identical, with natural leucine can be prepared artificially.

Leucippus, the founder of the Atomic School of Greek philosophy, and forerunner of Democritus (q.v.), was born in Abdera, and flourished in the beginning of the 6th century B.C.

Leuciscus, a genus of fresh-water fishes, of the family Cyprinidae, containing a great number of species, among which are the Roach, Dace, Chub, Minnow, &c.

Leucite (Gr. *leukos*, 'white'), a rock-forming mineral which occurs in the form of icositetrahedra belonging to the cubical system. It has a hardness = 5.5 - 6, and a specific gravity = 2.45 - 2.50. The colour is white, ash-gray, or smoke-gray. It usually contains many inclusions, such as olivine, argite, and other minerals, together with glass enclosures, gas-bubbles, and occasionally fluid lacuna. Unlike cubical minerals, it exhibits a certain degree of double refraction, believed to be due to conditions of unequal tension existing within the crystals. When exposed to a temperature of 500° C. the crystals become perfectly isotropic. Leucite occurs only in volcanic rocks, and those in which it occurs have a restricted distribution.

Leuckart. RUDOLF, zoologist, was born 7th October 1822 at Helmstadt, and studied at Göttingen. In 1850 he became professor of Zoology at Giessen, and in 1869 at Leipzig; he specially distinguished himself by his study of the Entozoa. His great work is *The Parasites of Man* (Eng. trans. by Hoyle, 1886). He died 6th February 1898.

Leucocythemia (Gr. *leukos*, 'white,' *cythos*, 'a cell,' and *haima*, 'blood') is a disease in which the number of white corpuscles in the blood is greatly increased, while there is a simultaneous diminution of the red corpuscles. The disease was noticed almost at the same time (in 1845) by John Hughes Bennett of Edinburgh and Virchow of Würzburg; the former giving in 1852 the name *Leucocythæmia*, while the latter gave it in 1847 the less expressive name of *Leukæmia* or *White Blood*. The increase of the white or colourless corpuscles seems to be always accompanied, and probably caused, by changes in some of the lymphatic tissues of the body. Of these by far the most common is enlargement of the spleen, which sometimes attains an enormous size. In many cases this is associated with enlargement of lymphatic glands, and less commonly with a peculiar change in the marrow of the bones; and occasionally one or both of these conditions may be present without enlargement of the spleen.

The first symptom usually noticed by the patient is enlargement of the abdomen, in consequence of the increase in size of the spleen. Weakness, breathlessness, hæmorrhages in various situations, and often enlargement of the liver succeed; and the disease almost always proves fatal in two or

three years at most. It may occur at any age; but is most common between twenty and fifty, and in the male sex. Nothing is known as to its cause, except that a considerable proportion (one-fifth or more) of those affected have at some previous time suffered from ague. Treatment seems sometimes to have proved effectual in the early stages; cases have been recorded where quinine, phosphorus, cod-liver oil, iodide of iron have arrested what appeared to be commencing leucocythemia. But after the disease is fully established all treatment has as yet proved unavailing.

Leucol. C_8H_7N , is an organic base obtained by the distillation of coal-tar, and is isomeric with quinoline.

Leucoma is the term applied to a white opacity of the cornea (see EYE). It is the result of acute inflammation, giving rise to the formation of cicatricial tissue on the ulcerated surface, or between the layers of the cornea. It is sometimes re-absorbed on the cessation of the inflammation, and the cornea recovers its transparency; but in many cases it is persistent and incurable.

Leucorrhœa (Gr. *leukos*, 'white,' and *rhœ*, 'I flow'), popularly called *whites*, is the name applied to an abnormal mucous or mucopurulent discharge from the female generative organs. It is a prominent symptom in many forms of female disease; and the treatment must be directed to the morbid condition on which it depends. Antiseptic or astringent vaginal douches are generally of use in diminishing the excessive secretion and the annoyance caused by it.

Leuctra, a village of Boötia, in ancient Greece, famous for the great victory which the Thebans under Epaminondas (q.v.) here won over the Spartan King Cleombrotus (371 B.C.).

Leuk (Fr. *Loèche*), a town (pop. 1411) in the Swiss canton of Valais, on the right bank of the Rhone, 15 miles above Sion. It is the railway station, on the Simplon railway, for the *Baths of Leuk* (4643 feet above sea-level), situated 5 miles northward at the head of the Dala gorge and the foot of the ascent over the Gemmi pass. At this hamlet of 650 inhabitants there are lodging-houses and hotels for the accommodation of patients and travellers. The springs have a high temperature (124-199° F.), are saline, chalybeate, and sulphureous, and are used both for drinking and bathing, chiefly in skin and stomacheal diseases. The patients (mostly French, Swiss, and Italians) remain many hours in the water, talking, reading, &c. See guide-books by Brunner (5th ed. 1887), Wolf (1886), and Von Werra (1886).

Leukas, LEUCADIA, or SANTA MAIRA, one of the Ionian Islands, lies close to the west coast of Greece; about 660 B.C. the Corinthians cut through the peninsula that joined it to the mainland. It resembles the Isle of Man in shape, and is 20 miles long by 8 wide, with an area of 110 sq. m. The backbone of the island is a ridge of white lime stone; hence the name (*leukos*, 'white'). Wine, olive-oil, and currants are the principal products. The island is much subject to earthquakes. Pop. 25,000, chiefly Greeks. The west coast is bold and precipitous, and terminates south in the abrupt headland (200 feet) known to the ancients as the Leucadian rock, on which stood a temple to Apollo, and from which once a year a criminal was hurled into the sea by way of sacrifice. It was from the same point that Sappho, the poetess, and Artemisia of Halicarnassus threw themselves into the waves.

The capital, Amaxioli or Lenkas, on the east coast, is the seat of an archbishop, and has a population of 3800. It was nearly destroyed by an earthquake in 1825. Venice was mostly mistress

of this island from 1684 to 1800; it was occupied by Britain in 1810. See IONIAN ISLANDS; also an account of the island by Partsch in *Ergänzungsheft*, 95, to *Petermann's Mittheilungen* (1889).

Leuthen, a village of Prussia, in Lower Silesia, 10 miles W. of Breslau, celebrated for the victory won there, 5th December 1757, by Frederick the Great, with 34,000 men, over the Austrians under Prince Charles of Lorraine at the head of 90,000. The Austrians lost 10,000 killed and wounded, 12,000 prisoners, and 116 pieces of artillery; the Prussians, 6,500 killed and wounded. The result was the reconquest of the greater part of Silesia by the Prussians.

Leutze, EMANUEL, painter, was born at Gmünd, in Wurtemberg, in 1816, was brought up by his parents in America (at Philadelphia and at Fredericksburg, Virginia), and afterwards studied and painted in Europe from 1841 to 1859, his home for fourteen years being at Düsseldorf. He settled in New York city in 1859, and died at Washington, 18th July 1868. His works include three scenes from the life of Columbus, several from English history, and a number depicting events in the war of the Revolution, including 'Washington crossing the Delaware.' One of his last works was the 'Westward Ho' mural picture for the staircase of the capitol at Washington.

Leuwenhoek. See LEEUWENHOEK.

Levaillant, FRANÇOIS, traveller and ornithologist, was born in 1753 of French parents living at Paramaribo, in Dutch Guiana. In 1777-80 he studied natural history in Paris, and then spent more than two years in exploring the southern parts of South Africa (1781-84). His death occurred at Sézanne, south of Epernay, on 22d November 1824. He published accounts of two of these expeditions, not altogether free from imaginative details and exaggerations, under the title *Voyages dans l'Intérieur de l'Afrique* (1790-96). Several books by him on birds are marred by the same faulty tendencies; those on African birds, on the new and rare birds of America and India, and on paroquets are the most valuable.

Levant (from the Ital. *Levante*, the 'Orient,' or 'Rising'—i.e. the East), a name employed to designate the eastern parts of the Mediterranean Sea and the coast regions of Syria, Asia Minor, and Egypt. In a wider sense, it is applied to all the regions eastward from Italy, as far as the Euphrates and the Nile.—*Levantine* is a name given to persons mainly of Frank extraction born in Turkey and the towns of the Levant.—*Levanter* is a stormy wind blowing up the Mediterranean from the Levant.

Levéé, the French name, used also on the Lower Mississippi (q.v.), for an embankment.

Levéé, originally a reception held in the monarch's bedchamber at the hour of rising (Fr. *lever*). See COURT, PRESENTATION AT.

Levellers, an ultra-republican sect or party which became noticeable in the parliamentary army in 1647, and two years later produced a formidable mutinous outbreak. The chief leader was John Lilburne (1618-57), who, whipped and imprisoned by the Star Chamber in 1638, had risen in the army to be lieutenant-colonel. He became an indefatigable agitator; thought Cromwell's republic too aristocratic, and demanded greater liberty of conscience and numerous parliamentary reforms; and was repeatedly imprisoned for the treason in his pamphlets. A part of the army mutinied in April 1649 in support of like views, and soon there were a thousand insurgents, who were speedily surrounded near London and forced by Cromwell into surrender.

Similar risings elsewhere were also swiftly dealt with.

Levelling. Level is a term applied to surfaces that are parallel to that of still water, or perpendicular to the direction of the plumb-line; it is also applied to the instrument employed in determining the amount of variation from perfect levelness. The instrument is a cylindrical glass tube very slightly convex on one side, and so nearly filled with water, or, what is better, with alcohol, that only a small bubble of air remains inside. The level is then mounted on a three or four legged stand, with its convex side upwards, and by means of a pivot and elevating screws is made capable of assuming any required position. If the level be properly constructed the bubble should lie *exactly* in the middle of the tube when the instrument is properly adjusted, and at the same time the line of sight of the telescope attached to the level should be accurately parallel to the surface of still water. In ordinary levels this first condition is seldom seen, and, instead, two notches are made on the glass to mark the position

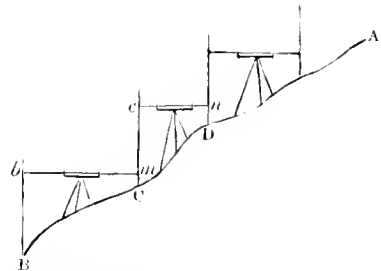

of the two extremities of the bubble when the instrument is level. The tube and bubble should be of considerable length to ensure accuracy. The leveller requires two assistants, each furnished with a pole from 10 to 14 feet high, and graduated to feet and inches, or feet and tenths of feet. If he wishes to measure the height of A above B, he may do this by beginning either at A or B. Let the latter be the case: then one assistant is placed at B, holding his pole upright; the other is sent forward to C (which must be below the level of the top of the pole at B); the surveyor, who places himself between them, reads off the height Bb, which he puts down in the back-sight column of his book, and then turns the level to C, reading off Cm, which is entered in the front-sight column. The surveyor and his assistant at B then take up new positions, the latter at D; the back-sight Cc and the front-sight Dd are read off, and the process is repeated till one of the assistants reaches A. The excess of the sum of the back-sights over that of the front-sights gives the height of A above B. A little consideration shows that this method only holds true when practised on a small scale, and consequently in extensive surveys the level (as found by the above method) must be reduced by an allowance for the earth's curvature. See works by F. W. Stumms (1884) and T. Holloway (1887).

Leven, a small seaport and police-burgh (1867) of Fife, on the Firth of Forth, at the mouth of the river Leven, 11 miles by rail N.E. of Kirkealdy. Pop. (1841) 1827; (1881) 3568; (1891) 4577. A good golf-links adjoins the town.

Leven, LOCH, a salt-water loch, between Argyll and Inverness shires, extending 11½ miles westward to a junction with Loch Linne, near Ballachulish, and broadening to 2½ miles. Its scenery is savage, and the flow and ebb of the tide very strong. See also LOCHLEVEN.

Lever. an inflexible rod—straight or bent, as the case may be—supported at some point of its length on a prop which is called the *fulcrum*, and having a *resistance* to be overcome and *power* to overcome it applied at other two points. The general principle governing levers of all sorts is

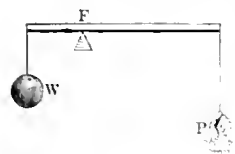

Fig. 1.

that the power and the resistance must tend to produce opposite rotations round the fulcrum, and that their moments—the product of either of them into the shortest distance between the line of the direction of its application and the fulcrum—must be numerically equal; or, in other words, the power and the resistance are in the inverse ratio of their respective

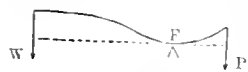

Fig. 2.

shortest distances from the fulcrum. When this is the case there is equilibrium; when either 'moment' predominates there will be rotation. These conditions may be fulfilled whether the power P, the fulcrum F, and the resistance W stand in the order PFW, PWF, or WPF; and hence levers are popularly divided into three classes. In the first class (PFW)—fig. 1 for a straight lever, fig. 2 for a bent one, equivalent to a straight lever since P and W are parallel—we have the Balance (q.v.), the spade (when used for raising earth), the seesaw; or, as double levers, scissors and pincers. In the second class (PWF, fig. 3) we have crowbars (P the hand, W the resistance of the body pushed, F the ground), boat-oars (P the hands, W at the rowlock, the resistance of the boat, F the comparatively fixed position of the oar-tip in the water), wheelbarrows; and, as double levers, nutcrackers (P the hand, W the nut, F the hinge).

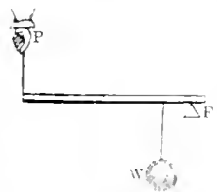

Fig. 3.

In the third class (WPF, fig. 4) we have fishing-rods, whips, umbrellas, and most instruments used with the hand alone, and coal- and sugar-tongs; and many instances in the muscular system—e.g. the biceps muscle and forearm of man (fig. 5), his deltoid muscle and shoulder, the pectoral muscle and wing of birds. Levers of the third class always work at a mechanical disadvantage as regards power; but what is lost in power is gained in speed and range of movement—e.g. the biceps muscle, since CA, fig. 5, is about one-sixth of the distance between the elbow-joint and the palm of the hand, must exert a 6 lb. pull on A in order to raise a 1 lb. mass in the hand (setting aside the weight of the forearm itself). Levers of the second order always act at a mechanical advantage as regards power; and in those of the first order a given pressure may overcome a greater, an equal, or a less resistance, according to the ratio of the arms. A subsidiary advantage of levers of the second order is that when a man lifts weight by one of the first order his power is limited to his own weight hung on the lever, whereas with one of the second order his push or pull is upward,

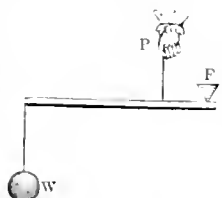

Fig. 4.

and he is thus able to exert his full muscular strength.



Fig. 5.

When a large mechanical advantage is required this may be obtained, without using bars inordinately long, by means of a combination of them (as in fig. 6). Here the levers have their arms in the ratio of 3 to 1, and a little consideration will make it plain that a power, P, of 1 lb. will balance the weight of 27 lb. But in this instance the particular defect of the lever as a mechanical power shows itself prominently; for if the 27 lb.



Fig. 6.

mass has to be lifted two inches, the power requires to act downwards through (2 x 27 or) 54 inches; and, as the extent of sweep of the power cannot be largely increased without inconvenience, the advantages of this contrivance are confined within narrow limits.

Lever. CHARLES, a popular novelist, chiefly remembered for the rollicking fun of his Irish stories, was born in Dublin, 31st August 1806. He graduated at Trinity College, Dublin, in 1827, and then removed to Gottingen, where he studied medicine, and subsequently returned to Dublin to complete his academic career. His most popular work, *Charles O'Malley*, is a reflex of his own college life in Dublin, and many of the incidents in the novel, as in many of his late productions, are drawn from his own experiences of the world. Probably in 1824, and certainly at some time between 1827 and 1832, he spent a considerable time in the backwoods of Canada and North America, and subsequently embodied his experiences in *Con O'gregan* and *Arthur O'Leary*. Returned to Ireland, he practised medicine first at Kilmish in County Galway, and afterwards at various other country towns, collecting material for his stories of Irish country life. Having married a Miss Baker, he went in 1837 to practise medicine at Brussels, and while there wrote *Harvey Lorrequer*, and afterwards *Charles O'Malley* for the *Dublin University Magazine*, then recently started. Returning to Dublin, he published *Jack Hutton* in 1841, and from 1842 to 1845 acted as editor of the *Dublin University Magazine*, and wrote *Nuts and Nutcrackers*, *Arthur O'Leary*, *Tom Burke of Ours*, and *The O'Donoghue*. In 1845 he again went off to the Continent, going first to Brussels, then to Bonn and Carlsruhe, where he lived for some time, and published the *Knight of Guyenne*. He then moved on to Florence, and wrote *Roband Cashel*, and thence to Spezzia, where *Luttrell of Arran*, *Con O'gregan*, *Sir Jasper*

Carver, and *The Dodd Family Abroad* were produced in rapid succession. Then, suddenly and completely changing his style, he wrote the *Fortunes of Glenore*, followed by a truly Irish story, *The Martins of Cro-Martin*, and *The Doltons*, the hero of which is an Englishman travelling on the Continent. Lever was then, in 1852, appointed by Lord Derby to be British vice-consul at Spezzia, and continued to write, publishing *Davenport Dunn, One of Them, Gerald Fitzgerald, Sir Brooke Fushbrooke, That Boy of Norcotts*, and contributing some racy papers to *Blackwood's Magazine* under the sobriquet of 'Cornelius O'Dowd.' On May 2, 1867, he was promoted by his old patron Lord Derby to the consulship at Trieste, where he died 1st June 1872. Lever's later books, though marked by greater care and more thought than those of the *Lorrequer* school, and even that strange and brilliant composition entitled *A Day's Ride*, are already dead; and it is only by his brilliant and racy sketches of a phase of Irish life which was passing away even as the sympathetic young chronicler caught its features that Lever still lives, and may continue to live when Ireland is as dull as Lincolnshire and as orderly as Clapham. Lever's wandering life on the continent of Europe, and especially in Belgium, where he fell in with a great number of Peninsular and Waterloo officers, and collected a vast store of traditions of the great battles and of those who fought them, gives an additional zest to many of his books. They are all something more than mere sketches of rollicking in Ireland, and their boisterous fun is relieved, and even refined, by constant changes of scene, the reflex of Lever's own wandering and wayward life, and of his own restless genius.

One unfortunate result of Lever's novels has been to create a false idea of Irish society, and still more of the Irish character. The Irish of to day at least are singularly unlike those portrayed in the novels of the *O'Malley* type, and, much as the social conditions of the country have altered in the last sixty years, a great deal of what was carelessly dashed off by Lever, and which at any time was but brilliant caricature, has been curiously enough accepted by most of his readers as an accurate representation of life in Ireland. Apart from his powers as a writer, Lever was one of the most brilliant conversationalists and one of the most agreeable companions of his time; a striking personality, he was at home everywhere, knowing everybody, a welcome guest in all societies and in all countries. The only published authority for Lever's life is a poor memoir by Fitzpatrick (1879; new ed. 1896). See also *Saturday Review*, vol. lxxix, p. 743.

Leveret, the young of the hare during the first year of its age.

Leverrier, URBAIN JEAN JOSEPH, a great French astronomer, was born at St Lo, in Normandy, 11th March 1811. He was admitted into the Ecole Polytechnique in 1831, was subsequently employed for some time under the board for the administration of tobacco, and as early as 1836 distinguished himself by his papers on the combinations of phosphorus with hydrogen and oxygen. Next year the place of teacher of astronomy at the Polytechnique was offered him, and in this way Leverrier was led to become an astronomer. His *Tables de Mercure*, and several memoirs on 'the secular inequalities,' opened to him the door of the Academy in 1846. At the instigation of Arago he applied himself to the examination of the disturbances in the motions of the planets, from which the existence of an undiscovered planet could be inferred; and, as the result of his laborious calcula-

tions, directed the attention of astronomers to the point in the heavens where, a few days afterwards, the planet Neptune was actually discovered by Galle at Berlin (see also ADAMS, J. C.). For this Leverrier was rewarded with the Grand Cross of the Legion of Honour, a professorship of astronomy in the Faculty of Sciences at Paris, and various lesser honours. When the revolution of 1848 broke out Leverrier sought distinction as a democratic politician; the department of La Manche chose him in May 1849 to be a member of the Legislative Assembly, where he at once became counter-revolutionary; and in 1852 Louis Napoleon made him a senator. In 1854 Leverrier succeeded Arago as director of the Observatory of Paris, an office which, save during an interval of three years (1870-73), he held till his death, 23d September 1877. See Bertrand's *Eloge* in the *Mém. de l'Acad. des Sciences*.

Levi, the third son of Jacob and Leah (Gen. xxix. 34). He is conspicuous through the part he took with his brother Simeon in the slaughter of the inhabitants of Shechem (Gen. xxxiv.). Jacob pronounced this curse on them both, that they should be scattered among Israel (Gen. xlix. 7). In Egypt the House of Levi had divided itself into three families, those of Gershon, Kohath, and Merari. At the distribution of Palestine no tribal territory was allotted to them, but only forty-eight scattered cities. In the Pentateuch they are set apart as the servants of the sanctuary, but they might not perform any priestly function, the priesthood being reserved for one Levitical family, that of Aaron. The history of the Levites has been matter of controversy. Some have assumed that Levi is simply the eponymous ancestor of the Levitical caste, and unsuccessful efforts have been made to deny that Levi was originally a tribe at all. See Wellhausen's *History of Israel* (1885).

Levi, LEONE, born 6th July 1821 at Ancona, settled in Liverpool in 1844, and in 1852 became professor of the Principles and Practice of Commerce in King's College, London. He died 7th May 1888. Among his works were *Commercial Law of the World* (1850; republished as *International Commercial Law*, 1873); *On Taxation* (1870); *History of British Commerce* (1872); *War and Its Consequences* (1881); *Wages of the Working Classes* (1885); *International Law* (1887).

Leviathan, a term that occurs five times in Scripture, in every case but one (Ps. civ. 26) denoting the crocodile. Some think that in Isa. xxvii. 1 it represents the great python which appears in Egyptian monuments.

Levita, ELIAS, a Jewish grammarian and exegete, was born at Neustadt on the Aisch, near Nuremberg, in 1465. One of the then frequent expulsions of the Jews forced him to seek refuge in Italy, where he held a high position as teacher of Hebrew, first in Venice, next in Padua, finally in Rome (1514). Cardinal Egidio here became his patron and pupil, but even he could not prevent Levita's again being expelled this city, together with his Jewish brethren, in 1527. He then returned to Venice, where he lived for the most part until his death, 1549. His principal exegetical works are on Job, the Psalms, Proverbs, and Amos. Other important works are his *Massoreth Hammassoreth*, a treatise on the vowel-points; a Hebrew grammar; and a Talmudic and Targumic Dictionary. Most of his works have been repeatedly edited and partly translated by Buxtorf, Munster, Fagnus, and others, who owed most of their Hebrew knowledge to Levita exclusively. He is called not only *Halevi*, but *Ashkvausi* ('the German'), *Habachur* ('the master'), &c.

Levites. See LEVI.

Leviticus. See PENTATEUCH.

Levkosia. See NICOSIA.

Levuka, till 1882 the capital of Fiji (q.v.).

Levnose. See SUGAR.

Levy (Fr. *levée*) is the compulsory raising of a body of troops from any specified class in the community for purposes of general defence or offence when the existing military forces are insufficient to meet the necessities of the case. When a country is in danger of instant invasion a *levée en masse* is sometimes made—i.e. every man capable of bearing arms is required to contribute in person towards the common defence. On less urgent occasions the levy may be restricted to a class, as to men between eighteen and forty years of age.

Lewald, FANNY, German novelist, was born of Jewish parents at Königsberg, on 24th March 1811, but professed Christianity in her seventeenth year. She began to write when about thirty, and from 1840 lived in Berlin; in 1855 she married Adolf Stahr (1805-76), the literary critic. She died at Dresden on 5th August 1889. Fanny Lewald was perhaps the most important woman novelist in Germany during the middle of the 19th century. She was possessed of keen powers of observation, and wrote in a sober, matter-of-fact style, which, however, was not incompatible with a strong undercurrent of restrained feeling. She was an especially enthusiastic champion of the emancipation of her sex. Her realistic tendencies brought her into conflict with the Countess von Hahn-Hahn, whose unreal sentimentalism she successfully parodied in *Diogenes* (1847). Her best book is perhaps *Von Geschlecht zu Geschlecht* (1863-65). An English translation of *Stella* (1884) appeared in the same year. At different times she visited many parts of Europe with her father and her husband; her books on Italy (1847) and Great Britain (1852) were the most valuable outcome of these journeys. See her *Meine Lebensgeschichte* (6 vols., 1861-63).

Lewes, the county town of Sussex, 50 miles S. of London, is picturesquely situated on the eastern declivity of one of the South Downs, at the foot of which flows the navigable river Ouse on its course to the sea at Newhaven, 7 miles distant. Pop. (1801) 4909; (1881) 11,199; (1891) 10,997. The chief objects of interest are the ruins of a priory and castle which once stood here, the former built (1072-78) by William de Warenne, Earl of Surrey, who with his wife Gundreda, a daughter of William the Conqueror, was buried within its precincts. Of the castle which stood on high ground in the centre of the town, the keep and gateway, the only portions now remaining, are occupied by the Sussex Archaeological Society as a museum. Lewes has seven churches, mostly Perpendicular in style, a county hall (1812), free library (1862), school of science and art (1868), and a town hall (1872). The chief trade is in corn, malt, coals, and lime, whilst newspaper printing and tanning are extensively carried on. Till 1867 the town returned two members to parliament, till 1885 one. A charter of incorporation was granted in 1881. Race meetings are held three times a year near Mount Haury on the Downs, where, on the 14th May 1264, a great battle was fought between Henry III. and the insurgent barons under Simon de Montfort. See works by Horsfield (2 vols., 1821-27), Mantell (1846), and Lower (3d ed., 1880).

Lewes, GEORGE HENRY, littérateur, was born in London, a popular comedian's grandson, 18th April 1817. Educated partly at Greenwich under Dr Burney, and partly in Jersey and Brittany, he

left school early to enter first a notary's office, and then the house of a Russian merchant. He next tried walking the hospitals, but could not stand the horrors of the operating-room; so in 1838 he proceeded to Germany, and remained there nearly two years, studying the life, language, and literature of the country. On his return to London he fell to work writing about anything and everything as a Penny Encyclopædist and Morning Chronicle, as a contributor afterwards to a dozen more journals, reviews, and magazines, and as editor of the *Leader* (1851-54), and of the *Fortnightly* (1865-66), which he himself had founded. He 'began life,' says Mr Frederic Harrison, 'as a journalist, a critic, a novelist, a dramatist, a biographer, and an essayist; he closed it as a mathematician, a physicist, a chemist, a biologist, a psychologist, and the author of a system of abstract general philosophy.' The change was rendered possible, Mr Leslie Stephen points out, by George Eliot's literary successes. Lewes was married unhappily and had children, when his connection with her began in July 1854; it ended only with his death at their house in Regent's Park, 30th November 1878. An intellect clear and sharp, if not remarkably strong, a wit lively and piquant, if not very rich, sympathies warm, if not wide, and a style as firm as it is graceful, made Lewes one of the best of critics and biographers; as a populariser of philosophy he was inferior to none, as a populariser of science inferior to very few.

His works, besides a tragedy and a couple of novels (1841-48), include the *Biographical History of Philosophy* (1843; recast in the 3d edition of 1867 as *The History of Philosophy from Thales to Comte*); *The Spanish Drama, Lope de Vega and Calderon* (1846); a *Life of Robespierre* (1848); *Comte's Philosophy of the Sciences* (1853), which is much more than a mere translation; the admirable *Life and Works of Goethe* (1855); *Seaside Studies at Ultramarine* (1858); *Philosophy of Common Life* (1859-60); *Studies in Animal Life* (1862); *Aristotle* (1864); *On Actors and the Art of Acting* (1875); and *Problems of Life and Mind* (1874-79), its five volumes dealing with 'The Foundations of a Creed,' 'The Physical Basis of Mind,' 'The Study of Psychology,' and 'Mind as a Function of the Organism.' See ELIOT (GEORGE), with works there cited, and an article by Anthony Trollope in the *Fortnightly* for January 1879.

Lewis, or SNAKE RIVER, the great southern branch of the Columbia (q.v.). See IDAHO.

Lewis. See LOUIS, and LEWIS-WITH-HARRIS.

Lewis, SIR GEORGE CORNEWALL, statesman and author, was born in London, 21st October 1806, son of Sir T. F. Lewis, Bart., of Harpton Court, Radnorshire, and was educated at Eton and Christ Church, Oxford, where in 1828 he took a first class in classics and a second class in mathematics. A pupil of Austin's, he was called to the bar of the Middle Temple in 1831, and succeeded his father as Poor-law Commissioner in 1839. He sat for Herefordshire from 1847 to 1852, and for the Radnor Boroughs from 1855. After holding minor government offices, he rose rapidly to be financial secretary to the Treasury, Chancellor of the Exchequer under Palmerston (1855-58), Home Secretary (1859-61), and Secretary at War. He succeeded his father as second baronet in 1855, and died 13th April 1863. He was an earnest and sincere politician, and his business capacity, sound sense, varied knowledge, and moral and intellectual qualities made him a notable figure in the public and political life in England.

His extraordinary versatility may be gathered from a list of his works, which include a treatise on the *Origin and Formation of the Romance Language* (1835), *The Fables of Bæmus, The Use and Abuse of Political Terms, The Influence of Authority in Matters of Opinion* (1850),

his famous *Inquiry into the Credibility of Ancient Roman History* (1855—against Niebuhr), *The Method of Observation and Reasoning in Politics, Local Disturbances and the Irish Church Question* (1836), *The Government of Dependencees, Herefordshire Glossary, The Astrology of the Ancients* (1859), and *Dialogue on the Best Form of Government* (1859). He was editor of the *Edinburgh Review* from 1852 to 1855. See his *Letters* (1870), and *Bagehot's Literary Studies* (1879).

Lewis, MATTHIAS GREGORY ('Monk Lewis'), was born in London, 9th July 1775, and educated at Westminster, at Christ Church College, Oxford, and at Weimar, where he was introduced to Goethe. In 1794 he went as an attaché to the Hague, and there, inspired by Glanvill (his mother's favourite author) and the *Mysteries of Udolpho*, wrote at nineteen *Ambrosia, or the Monk* (1795), the gruesome, unclean romance which made him so famous that in 1798 his invitation to dine at an Edinburgh hotel could elate Scott as nothing before or afterwards. A musical drama, *The Castle Spectre* (1796), *The Bravo of Venice* (1804), and a host more of blood-and-thunder plays, novels, and tales are happily forgotten; but two lines at least survive of one of his ballads, *Alonso the Brave*. In 1796 he entered parliament as a silent member, and in 1812 he inherited from his father two large estates in Jamaica. So to better the condition of his slaves there, good-hearted, lachrymose, clever little 'Mat' forsook the society of the Prince Regent, Byron, and all his other great friends, and made the two voyages, in 1815 and 1817, which furnished materials for his one really valuable work, the posthumous *Journal of a West India Proprietor* (1834). On his way home, in the Gulf of Florida, he died of yellow fever, 13th May 1818, and was buried at sea. See his *Life and Correspondence* (2 vols, 1839).

Lewisham, in Kent, 6 miles SSE. of Charing Cross, since 1885 a parliamentary borough, with 67,500 inhabitants.

Lewisia, a genus of plants, of the natural order Portulacaceae (see PURSLANE), named in honour of the American traveller, Meriwether Lewis (1774-1809). *L. rediviva* is found in the regions of his explorations, on the west side of the Rocky Mountains. Its thick, branching roots are gathered and are highly valued by the Indians as nutritive, and also as restorative. It has a showy rose-coloured flower. Another species, *L. brachycalyx*, is found in Utah.

Lewiston, a city of Maine, on the Androscoggin River, 35 miles N. of Portland. The river, which is crossed by several bridges, has here a fall of 50 feet, and the water-power is distributed by a dam and canal to numerous mills and factories. The principal manufactures are woollens and cottons, and these are produced in very large quantities. Lewiston contains a Baptist college. Pop. (1880) 49,983; (1890) 21,701.

Lewis-with-Harris, an island of Scotland, the largest and most northerly of the Outer Hebrides, separated from the mainland by the Minch, and containing the town of Stornoway (q.v.), 43 miles NW. of Poolewe and 180 N. by W. of Oban. Its length is 60 miles; its greatest breadth is 28 miles; and its area is 859 miles, of which 683 belong to Lewis, the Ross-shire portion, in the north, and 176 to Harris, the Inverness-shire portion, in the south. The coasts are wild and rugged, the chief indentations being Broad Bay and Lochs Erisort, Seaforth, Resort, and Roag. The Butt of Lewis, a promontory at the extreme north, rises sheer from the sea to a height of 442 feet. Gneiss is the predominant rock; and the surface, attaining 2662 feet in Harris and 1750 in Lewis, consists mainly of hill, moor, and moss,

treeless and almost shrubless, with much peat and fresh-water lakes innumerable. Less than 4 per cent. of the entire area is in cultivation. In 1844 'the Leys' was purchased for £190,000 from the Mackenzies of Seaforth by Sir James Matheson (1796-1878), who expended £330,000 on improvements. Pop. (1801) 12,164; (1831) 18,410; (1891) 30,726, mostly Gaelic-speaking. See CALLERISH, CROFTERS, HERRIDES; and W. A. Smith's *Louisiana* (1875).

Lexicon. See DICTIONARY.

Lexington. (1) capital of Fayette county, Kentucky, stands in the fertile blue-grass region, at the junction of four railways, 77 miles S. of Cincinnati. It is a handsome city, its principal edifices the court-house, the state university, and the state lunatic asylum. The fine Henry Clay monument also is noteworthy. There are manufactures of spirits, hemp, and, especially, of tobacco. Pop. (1880) 16,656.—(2) A village of Massachusetts, 11 miles WNW. of Boston, where the first blood of the Revolution was shed, April 19, 1775. A monument has been erected in memory of the eight minute-men who fell in this first conflict.—(3) Capital of Lafayette county, Missouri, on the Missouri River, 42 miles by rail (84 by water) E. of Kansas City. It contains Baptist and Methodist ladies' colleges, and has manufactures of hemp and woollen goods. Pop. 3996.—(4) A pretty village of Virginia, on the North River, 32 miles NNW. of Lynchburg, is the terminus of the James River and Kanawha Canal, and contains the Washington and Lee University and the Virginia Military Institute. Here Robert E. Lee and 'Stonewall' Jackson are buried. Pop. 2771.

Lex Talionis, the law of retaliation, common among all ancient and barbarous nations, by which an eye for an eye and a tooth for a tooth was considered the appropriate punishment.

Leyden, or LEIDEN, a town of Holland, stands on the Old Rhine, 5 miles from the North Sea, and by rail 9 miles N. by W. of the Hague and 31 W. of Utrecht. It is a typical Dutch town, spotlessly clean, with canals bordered by avenues of trees, and sleepy squares and streets. Its predominant characteristic is an air of academic repose; and the town is the seat of a celebrated university, which formerly attracted students from all parts of Europe, including Sir Thomas Browne, Evelyn, Boswell, Goldsmith, John Wilkes, Alexander Carlyle, Alexander Monro, and several other distinguished Scottish surgeons, and numbered amongst its professors some of the greatest names in the world of learning: Grotius, Descartes, Salmasius, Scaliger, Boerhaave, Hemsterhuis, Ruinken, Valekenae, &c., besides Arminius and Gomarus, have all either studied or taught at Leyden. It was founded in 1575 by William of Orange as a reward to the citizens (they themselves selecting this boon in preference to a remission of taxes) for their heroic defence against the Spaniards from October 1573 to October 1574. At the present time it is frequented by about 800 students, and has some fifty professors and teachers. Its collateral institutions include a library of 160,000 volumes and 5000 MSS., many of them valuable oriental and Greek MSS.; a botanic garden, which has counted Linnaeus and Boerhaave amongst its directors; a museum of natural history, one of the finest and best arranged in Europe; a museum of antiquities, with especially valuable Egyptian monuments; an ethnographical museum, the nucleus of which was Siebold's Japanese collection; and an observatory. The senate-hall is hung with the portraits of more than a hundred celebrated Leyden professors. The town-art museum contains pictures by Rembrandt, Jan Steen, Gerard Douw,

Lucas of Leyden, the family Mieris—all natives of the town, and others. Here too were born some of the Elzevirs, the celebrated printers, who carried on a branch of their business in Leyden, and John of Leyden, the Anabaptist. The quaint and picturesque town-hall dates from 1574-98. There are nearly a score of churches, the most notable among them being St Peter's, with monuments to Boerhaave, Scaliger, Camper, Arminius, &c., and St Paneras, with a monument to Van der Werf, the hero of the siege. In the centre of the town stands an old round tower, which is said to date from the Roman occupation. Leyden was in the 15th century famous all over Europe for its manufactured cloth, baize, and camlet. The same industries, but to a much less extent, together with the manufacture of cotton, twine, and yarn, the dyeing of cloth and leather, &c., are still carried on. Leyden is the seat of a school of navigation. In 1650 the population numbered 100,000; but a century later it had fallen to three-quarters of that number, and by the beginning of the 19th century to 30,000. In 1876 it was 40,724, and 46,379 in 1889. In 1807 a portion of Leyden was destroyed by the explosion of a barge laden with gunpowder on one of the canals.

Leyden, JOHN, poet and oriental scholar, was born, the son of a shepherd, at the village of Denholm, Roxburghshire, 8th September 1775. In 1790 he entered Edinburgh University, and was licensed as a preacher or 'probationer' of the Church of Scotland in 1798. He proved an ardent and enthusiastic student, with a hunger for knowledge, which led him into studies out of the routine, including many European and oriental languages. His strong native talent and varied gifts and attainments, in spite of his uncouth manners, secured him the attention of some of the most eminent persons of the day, including Constable, Henry Maekenzie, Ritson, the Duchess of Gordon, Lady Charlotte Campbell, and Richard Heber, by whom he was introduced to Scott. He aided the latter in gathering materials for his *Border Minstrelsy*, contributing an article on fairy superstitions, and on one occasion he walked between 40 and 50 miles to procure the words of a ballad which were wanting. He was also a contributor to Lewis's *Tales of Wonder*. His first prose work was *Discoveries and Settlements of Europeans in Northern and Western Africa* (1799). Meanwhile his translations and original poetical contributions to the *Edinburgh Magazine* had attracted attention. For a period of six months (1802) he edited the *Scots Magazine*. Before leaving his native country he had completed his *Scenes of Infancy, descriptive of Terribilitate* (1803). In 1803 he sailed for India as assistant-surgeon on the Madras establishment. After four months' service in Madras general hospital he was appointed surgeon and naturalist to the commission for the survey of Mysore and Travancore (1804). His health gave way, he was five times given up by the physician, but sick or well he continued his acquisition of languages. He resided for a time at Penang; came back to Calcutta (1806); wrote an essay on Hindustani dialects; was appointed professor in the Bengal College, and afterwards judge at Calcutta. Through the influence of Lord Minto he was appointed commissioner of the Court of Requests, then assay master of the mint. Meanwhile he translated the Gospels into five different languages. When the expedition against Java was undertaken Leyden accompanied Lord Minto thither as interpreter; and at Batavia, in the exploration of a musty, unventilated library, which contained many Indian manuscripts, he contracted a fever, of which he died, August 27, 1811.

Leyden's versification is soft and musical, but his ballads with their marvellous melody have

taken a higher place than his longer poems. Next after Scott and Hogg, says Principal Shairp, he has done most to illustrate his native region. His attainments as an orientalist were extraordinary; he had a greater or less acquaintance with at least thirty-four languages or dialects. Lord Cockburn speaks of him as ever in a state of excitement, and ever panting for things unattainable by ordinary mortals. A monument to Leyden has been erected at Denholm (1861). Scott describes him as of middle stature, of athletic build, features well proportioned, lively dark eyes, a clear, somewhat ruddy complexion, and light-brown hair. Leyden's chief literary remains are a preliminary dissertation to an edition of the *Complaynt of Scotland* (1801); an essay on the 'Languages and Literature of the Indo-Chinese Nations,' printed in *Asiatic Researches*, vol. xix.; his *Memoirs of Baber* (q.v.), partly by Erskine (1826); *Malay Annals* (1821). See his *Poetical Remains*, by Morton (1819); *Poems and Ballads*, with reprint of memoir by Scott (1875); and *Poetical Works*, with memoir by T. Brown (1875). See also *J. Constable and his Literary Correspondents* (3 vols. 1873); and *Calcutta Review*, No. 61.

Leyden, LUCAS VAN. See LUCAS.

Leydenburg, or Lydenburg, a town in the Transvaal (pop. 2000), on an elevated plateau, about 180 miles NW. of Delagoa Bay. The district is rich in minerals, and gold has been worked since 1873.

Leyden Jar. See ELECTRICITY.

Leys, HENRI JEAN AUGUSTE, Belgian painter, was born on 18th February 1815 at Antwerp, in which city most of his life was spent, and where he died on 26th August 1869. He was created baron by Leopold I. in 1862. Leys is one of the best modern artists in the style of the old Flemish masters. His most valuable and most characteristic pictures are inspired by the private life and stirring history of his native land—Rembrandt's Studio (1837), 'A Flemish Wedding' (1839), 'Public Worship in Antwerp Cathedral,' 'A Village Fête,' 'A Musical Party' (1846), 'Rubens Feasted by the Gunsmiths of Antwerp' (1851), 'New-year's Day in Flanders,' 'Luther Singing in the Streets of Eisenach' (1862), 'Erasmus in his Study,' 'Institution of the Golden Fleece,' and a series of frescoes in his own dining-room representing the history of a 'Flemish Festival.' The last years of his life were occupied in painting six scenes from the history of Antwerp in the 16th century on the walls of the great hall in the town-house of Antwerp. Alma Tadema studied under Baron Leys. See Sulzberger's *Henri Leys* (Brus. 1885).

Leze Majesty (Norman Fr.; Lat. *lesa majestas*), an offence against sovereign power. See TREASON.

Lhassa ('the Seat of the Gods'), the capital of Tibet and sacred city of the Lamaist Buddhists, is situated in a fertile plain, 11,910 feet above the sea, and surrounded by mountains ranging from 2000 to 1000 above that altitude. The city stands in 29° 30' N. lat. and 90° 57' E. long., about 45 miles NE. of the junction of the Ki-chu with the Yaro San-po; the former river flows past the city westwards about a mile to the south. The city proper is surrounded with a wall, and consists of a closely packed assemblage of good stone and brick houses and shops, with ecclesiastical buildings, chiefly temples, sandwiched in between. Outside this central city lie extensive suburbs, the houses standing in gardens, ranged on each side of broad, tree-shaded streets. The monasteries, some fifteen in number, are scattered over the plain and in the suburbs. Just outside the central city on the northwest stands a conical hill, Potala, which is thickly encrusted with palaces and temples,

their roofs all gilded: this is the abode of the Grand Lama (see LAMAISM). If Potala is the Vatican of the Buddhists, they have their St Peter's in the temple of Labrang or Cho-khang, which overlooks the great square in the very heart of the city. The most sacred of its shrines contains a life-size image of Buddha and images of several other notabilities of the Buddhist faith. Near the north end of the city stand two famous temples, known as Ramo-Chih and Morn, the monks of which practise sorcery and magic, and grant degrees in the same. The most celebrated of the monasteries are perhaps those known as the Four Ling, from the heads of which the regent of Tibet is always chosen: Chiakpori, the medical university; Dai-pung, the school of Buddhist philosophy; and the Galdan Lamaserai (25 miles N.E. of the city), the abbot of which is one of the highest dignitaries in the Buddhist church. But Lhasa is something more than the ecclesiastical and religious centre of the Buddhist faith; it is an important trading centre, a terminus for caravans to and from India, Cashmere, Burma, China, Mongolia, and Turkestan. The principal article of commerce is tea; next to this come silks, carpets, rice, tobacco, horses, sheep, mink, European and Indian manufactured goods, &c. There is an important colony of Kashmiris, who, though Mohammedans, are tolerated because of their usefulness as traders. The resident population, exclusive of the garrison and the monks, is about 15,000. The number of inmates in the individual monasteries ranges from 3000 to 7000, or even more. The Chinese maintain a small garrison (some 500 men); and the Chinese emperor is represented by two resident officials, who, though they do not sit on the supreme council of the Grand Lama (who is also the civil ruler of Tibet), exercise considerable influence on the government indirectly. The resident population is, however, generally augmented by a floating population of pilgrims and traders, in numbers varying from 40,000 to 80,000. The women of Lhasa go about with perfect freedom; they stain their faces with black spots. Tibet became tributary to China about 1720, and has never since shaken off the yoke. Owing to the jealous exclusiveness of the Tibetan and Chinese authorities, and the close watch they keep all along the frontiers, it is believed that only three Europeans have entered Lhasa during the 19th century, namely the Englishman Manning (in 1811-12) and the Frenchmen Huc and Gabet (1846), though several Europeans reached the city in previous centuries. But since about 1866 specially trained Indian explorers have from time to time been sent into Tibet by the Calcutta authorities; to them we owe most of our newer information about that strange country.

See Huc's *Travels in Tartary, Tibet, &c.* (2 vols. 1844); *Narrative of the Mission of G. Beale and of the Journey of T. Manning to Lhasa*, edited by C. Markham (1876); 'Explorations by A — k in Tibet,' in *Proc. Roy. Geog. Soc.* (1885); and papers by G. Sandberg, in *Nineteenth Century* (October 1889) and *Contemp. Review* (July 1890).

Lherzolite, an igneous rock consisting of a granular or fine-grained aggregate of olivine, pyroxene, enstatite, and peridot. It derives its name from Lake Lherz in the Pyrenees.

L'Hôpital, MICHEL DE, French statesman, was born at Aigueperse in Auvergne in 1504, studied law at Toulouse and Padua, and settled as an advocate in Paris when about thirty years of age. In 1547-48 he represented Henry II. at the Council of Trent; then for some years he held high office in the household of Margaret of Valois, Duchess of Berry. His appointment in 1554 as superintendent of finances was but the preliminary to his nomination as chancellor of France six years later. His

policy was one of moderation; especially did he endeavour to assuage the fierce rancour of the religious quarrel by staying the hand of the Catholic persecutors, by resisting the introduction of the Inquisition, and by promoting such conferences, &c. as that of Poissy. But after the peace of Amboise (1563) he lost ground with Catharine de' Medici, and in 1568 he resigned the chancellorship. He spent the rest of his life in retirement on his estate of Vignay near Etampes, and died there (or at Belesbat) on 13th March 1573. His Latin poems, speeches, memoirs, &c. were published in 5 vols. in 1824-25. See *Life by Villemain* (new ed. 1874) and monographs by Taillandier (1861) and Dupré-Lasale (1875).

Liability (Limited) Acts. See COMPANY.

Liability of Employers. An employer is in law responsible for reparation of wrongs or injuries done to strangers by his servants while they are acting within the course and scope of their service. But where a master has forbidden the doing of the thing from which damage arises, or where a servant wilfully or maliciously does an injurious act to serve his own private ends, the master will not be liable. The Employer's Liability Act of 1880 so far extended the favour of the law to workmen as to make employers answerable to their servants for the negligence of those to whom they have delegated their authority. It gave, in certain cases of injury specified in the act, the same right of reparation to workmen against their employers as is enjoyed by strangers. But it was limited in its scope, and did not apply to servants not engaged in manual labour; nor was any provision made against employers and workmen contracting themselves out of the act. The Workmen's Compensation Act of 1897 still further extended the liability of employers by making them liable to their workmen for all injuries arising out of their employment from whatever cause, except their own wilful misconduct. 'Negligence' is not necessary to create liability, and even where the greatest care is taken the employer is still liable, as he is also to workmen employed by a sub-contractor. Any scheme of 'contracting out' of the act must be certified by the Registrar of Friendly Societies to be as favourable to the workmen as the act itself. The act was originally limited to certain specified industries, but practically included all workmen except agricultural labourers, seamen, and domestic servants; and the amending act of 1900 extended its application to agricultural labourers in the widest sense of the term. The amount of compensation is as follows: when a workman is killed, leaving dependents, a sum from £150 to £300; when no dependents are left, a sum not exceeding £10 for medical and funeral expenses; when total or partial disablement results, a weekly payment not exceeding £1. The liability thus imposed has been met by various forms of insurance, mainly supplied by accident insurance companies. See DAMAGES; and MASTER AND SERVANT.

Lia Fail. See CORONATION.

Liakhov Islands. See NEW SIBERIA.

Lianas, a term first used in the French colonies, in the form *lianes* (from *lier*, to bind), for the woody, climbing, and twining plants which abound in tropical forests. Such plants are comparatively rare in colder climates, although the honeysuckles and some species of Clematis afford familiar examples of them; but the lianas of tropical countries overtop the tallest trees, descend again to the ground in vast festoons, pass from one tree to another, and bind the whole forest together in a maze of living network, and often by cables as thick as those of a man-of-war. Many parts of the forest, as in the alluvial regions of the Amazons

and Orinoco, thus become impenetrable without the aid of the hatchet, and the beasts which inhabit them either pass through narrow covered paths, kept open by continual use, or from bough to bough far above the ground. Many lianas—as some of the species of *Wrightia*—become tree-like in the thickness of their stems, and often kill by constriction the trees which originally supported them; and when these have decayed the convolutions of the lianas exhibit a wonderful mass of confusion magnificent in the luxuriance of foliage and flowers. No tropical flowers excel in splendour those of some lianas. Among them are found also some valuable medicinal plants, as sarsaparilla (*Smilax*, order Liliaceæ). The rattans (*Calamus*, order Palmaceæ) and vanilla (order Orchidaceæ) are lianas. Botanically considered, lianas belong to orders which are often quite different. Tropical plants of this description are seldom seen in our hot-houses owing to the difficulty of their cultivation.

Lias. The lias is the lowest division of the Jurassic System (q.v.). The beds composing it may be considered as the argillaceous basis of that series of rocks, consisting of more than a thousand feet of alternations of clay and limestone, with but a few unimportant deposits of sand. It consists of the following groups: Upper Lias (400 feet), Marlstone (200), Lower Lias (900).

The Upper Lias consists of thin limestone beds scattered through a great thickness of blue clay, more or less indurated, and so aluminous that it has been wrought for alum at Whitby. Above this clay come sandy deposits. The Marlstone is an arenaceous deposit, bound together either by a calcareous or ferruginous cement, in the one case passing into a coarse shelly limestone, and in the other into an ironstone, which has been extensively wrought both in the north and south of England. The Lower Lias beds consist of an extensive thickness of blue clays, intermingled with layers of argillaceous limestone. In weathering, the thin beds of blue or gray limestone become light brown; while the inter-stratified shales retain their dark colour, giving the quarries of this rock at a distance a striped or ribbon-like appearance, whence it is supposed the miner's name lias or layers is derived.

The Lias is highly fossiliferous, the contained organisms being well preserved; the fishes are often so perfect as to exhibit the complete form of the animal, with the fins and scales in their natural position. Numerous remains of plants occur in the lignite and in the shales. The name Gryphite Limestone has been given to the Lias, from the great quantities of *Gryphaa uncinata*, a kind of oyster, found in it. Fish remains are frequently met with; the reptiles, however, are the most striking forms. They are remarkable for the great numbers in which they occur, for the size which many of the species attain, and for the adaptations in their structure which fitted them to live in water. The most noteworthy are species of *Ichthyosaurus* and *Plesiosaurus* (q.v.).

The Liassic rocks extend in a belt of varying breadth across England, from Whitby, on the coast of Yorkshire, south to Leicester, then south-west by Gloucester to Lyme Regis in Dorsetshire.

Libanius, a Greek sophist or rhetorician, was born at Antioch, in Syria, about 314 A.D. He studied at Athens, and began to teach there so successfully that he soon moved to Constantinople. There his lectures were so attractive that he emptied the benches of the other teachers of rhetoric, who had him expelled from the city on a charge of 'magic.' He then proceeded to Nicomedia; but after five years returned to Constan-

tinople. Ultimately, in 354, he settled down in his native city, where he died about 393. Libanius was the instructor of St Chrysostom and St Basil, who always remained his friends, though Libanius was himself a pagan, and a great friend of the Emperor Julian. His works, which are mostly extant, consist of orations, declamations, letters, &c. The most complete edition of the orations and declamations is that by Reiske (4 vols. 1791-97), and of the letters that by J. C. Wolf (1738). See Lives by Petit (Paris, 1866) and Sievers (Berlin, 1868).

Libanon. See LEBANON.

Libation (Lat. *libare*, 'to pour out'), literally, anything poured out before the gods as an act of homage or worship; a drink-offering. The term was often extended in signification, however, to the whole offering of which this formed a part, and in which not only a little wine was poured upon the altar, but a small cake was laid upon it. This custom prevailed even in the houses of the Romans, who at their meals made an offering to the Lares in the fire which burned upon the hearth. The libation was thus a sort of heathen 'grace before meat.' Even so late as the last quarter of the 19th century Mr Bent found at Samos the *spondi* or libation poured out on the floor before drinking.

Libau, a seaport of Comland, Russia, on the Baltic, by rail 146 miles W. by S. of Riga. It possesses a fine harbour, admitting vessels that draw 17 and 18 feet, and free from ice except for less than a fortnight in the year. Its importance as a point of export has greatly increased of late years. Its exports, consisting of grain, linseed and linseed oil-cake, petroleum, eggs, spirits, flax, hemp, &c., have an annual value of £3,000,000 or more (British trade constituting a fourth); its imports, chiefly coals, herrings, artificial manures, cotton, dyewood, and iron, under £2,000,000 (British trade nearly half of that). In 1890-95 the Russian government spent £2,500,000 on constructing a first class naval and commercial harbour. There already existed shipbuilding-yards and a school of navigation. The industries include iron-founding, brewing, oil-pressing, &c. Libau is much frequented as a seaside resort. One of the churches contains an organ (1886), one of the largest in the world. Pop. (1874) 10,767; (1880) 27,418; (1895) 39,000, mostly of German nationality.

Libel is any publication by printing, writing, painting, or the like signs, tending to injure the reputation of any one or expose him to hatred or contempt. A blasphemous, treasonable, or seditious publication is also termed a libel. Slander (q.v.), on the other hand, is defamatory spoken matter. An action for libel will lie though it cannot be shown that any appreciable pecuniary loss or damage has resulted from the publication; such loss or damage is an inference of law when the writing, &c. either is obviously defamatory or was so in the circumstances. Any definite loss is called special damage, and if properly brought before the court is taken into account when compensation is awarded.

In England the libelled party may seek redress civilly or criminally. If civilly he must prove that the matter was published of him falsely and maliciously, for the truth of the alleged libel (*justification*) is an absolute defence to a civil action. The defendant, besides repelling these pleas, may also bring forward some special defences. Thus, he may allege privilege, which is either *qualified* or *absolute*. Qualified privilege arises where matters of private interest are concerned. So a communication between employers as to the character of a servant is, if made in good faith and without express malice, protected. Absolute privilege arises where

the administration of justice or affairs relating to the public service are involved. Thus, statements in a judicial affidavit, or in a report properly made by an officer to his superior cannot afford a cause of action (see CONFIDENTIALITY). The Statute of Limitations also provides that actions for libel must be commenced within six years of the occurrence of the act complained of. Criminally, the remedy for a libel is by indictment (usually after proceedings before a magistrate), or (though more rarely) by criminal information. This last is either filed by the Attorney-general himself, in which case it is called an *ex officio* information, or by the queen's coroner and attorney by the direction of the Queen's Bench Division on the application of some private individual. An *ex officio* information is usually for a libel that seems to threaten some danger to the state; in the other kind of criminal information, as the alleged offence is against a private person, it must be shown that the ordinary remedy is inapplicable.

The net, so to speak, of the criminal law is much more comprehensive than that of the civil law. Thus, a prisoner may be prosecuted for libelling a dead person, if an attempt to bring contempt and scandal on the deceased's relatives can be proved; the libel need not have been published to a third party; it may have been directed against a company or sect, and not against any particular individual; it may be quite true, but unless its publication was for the public advantage (even this limited defence was only introduced by Lord Campbell's Act of 1843) this is no answer. In all these cases the civil law affords no remedy. Previous to 1792 the judges took upon themselves to decide whether the matter was libellous or no, leaving merely to the jury the question of publication; but in that year Fox's Act declared and enacted that the jury should have power to 'give a general verdict of guilty or not guilty upon the whole matter put in issue upon the indictment or information.' Besides the common law various statutes make libels against private persons, and also seditious and blasphemous libels, punishable by fine or imprisonment. But prosecutions for the last kind, except under very special circumstances, are not at the present day of probable occurrence. 'If,' said Lord Coleridge, in the modern case (1883) of the Queen *v.* Ramsay and Foote, 'the decencies of controversy are observed, even the fundamentals of religion may be attacked without a person being guilty of blasphemous libel.' Though this dictum has been questioned, it may safely be taken as a correct exposition of the present state of the matter. See BLASPHEMY, SEDITION.

The law of libel as it affects newspapers requires some special notice. Under Lord Campbell's Libel Act of 1843 the defendant in any action for libel contained in a public newspaper may plead absence of gross negligence and malice, and that he published an apology at the earliest moment possible. He is also at liberty, on filing such plea, to pay into court a sum of money by way of amends. The Newspaper Libel and Registration Act, 1881, as amended by the Law of Libel Amendment Act, 1888, provides that fair reports of proceedings at public meetings and in the law-courts shall be privileged; that actions against various defendants for libels practically the same may be consolidated; that before criminal proceedings are taken against persons connected with a newspaper for a libel therein the leave of a judge at chambers must be obtained; that defendants in libel actions and their wives are competent, though not compellable, witnesses; that in proceedings before magistrates matters of justification may be gone into, and that there may be a summary conviction followed by a fine not exceeding £50 for libels of a trivial char-

acter. In Scotland the law of libel is different in some important respects from that of England. The chief points are: (1) there is no radical distinction between libel and slander, both are equally defamatory; (2) damages are awarded as a solatium for wounded feelings; (3) libel and slander are actionable, though not what is technically termed in England *published* i.e. communicated to a third person; (4) reports of public meetings are more protected by the common law of Scotland than by the common law of England, though the exact limit has not been judicially settled; (5) the Scotch system of public prosecution renders criminal charges for libels on individuals extremely rare.

In the United States the law of libel follows the common law of England, except that the so-called Seditious Law (1798) expired in 1801, and has never been renewed, and that, generally speaking, it is a valid defence, whether in civil or criminal prosecutions, to show that the matter complained of was true and was published for justifiable ends. Privilege, however, is much further extended than in England.

Libel has several special legal meanings. In the English spiritual courts it is 'a declaration or charge drawn up in writing on the part of the plaintiff which the defendant is obliged to answer.' In the civil and criminal courts of Scotland it is the form into which the complaint against the defender or panel is put. It is also the name for the written charge against an accused person in a church court in Scotland.

The leading English text-book on libel is Odgers (2d ed. 1887; supplement, 1890). Earlier treatises by Starkie and Folkard are now out of date. Fraser's *Law of Libel in its relation to the Press* (1889), and Shortt's *Law relating to works of Literature and Art* (2d ed. 1884) are useful for reference. In Scotland the special treatise by Borthwick (1826) is antiquated; the last editions of Erskine & Bell supply the best information. Guthrie Smith's *Law of Damages* (2d ed. 1889) may also be consulted.

Libellula. See DRAGON-FLY.

Libel. See BAST.

Liberals. See WHIGS.

Liberia, a Negro republic on the Pepper Coast (Guinea) of West Africa, extending north and east of Cape Palmas. The coast-line measures about 500 miles. The boundaries in the interior are not determined, but the republic is considered to extend inland for a distance of 200 miles. The coast-region consists of mangrove swamps, lying behind a belt of sand dunes, is traversed by numerous rivers, and interrupted by projecting headlands of rock. About 20 miles or so inland the surface begins to rise into undulating uplands. The climate and vegetation are tropical. The temperature is pretty even, scarcely ever less than 75° F. or more than 88° F. The rainy season lasts about seven and the dry season five months. The soil is well adapted for the cultivation of coffee, the principal crop grown after the food-plants rice and manioc. The more important articles of export are coffee, sugar, palm-oil and palm-kernels, cocoa, arrowroot, caoutchouc, ivory, kola nuts, &c. The total value of the trade does not probably much exceed half a million sterling. The population amounts to 1,068,000, of whom 18,000 are liberated American slaves and their descendants, the remainder indigenous Negroes, including the Kroomen (q.v.). Capital, Monrovia (pop. 3000), now greatly decayed. Liberia owes its origin to the American Colonising Society, which in 1821 bought land on this coast and settled a small body of freed African slaves. The colony grew and prospered; new-comers arrived in large numbers from the United States, and fresh lands

continued to be bought. In 1847 the free and independent republic of Liberia was constituted; and it has enlarged its boundaries at least four times since then, being joined ten years later by the Negro republic Maryland (founded as a colony in 1821, as a republic in 1854), to the east of Cape Palmas. The constitution of Liberia is modelled on that of the United States: there are a president and House of Representatives (13 members), elected for two years, and a Senate (8 members), elected for four years. No white man is allowed to acquire citizen's rights or to hold property. There is no standing army, but all citizens capable of bearing arms are enrolled in the militia. Slavery is declared illegal. Complete religious toleration exists, the Methodist forms prevailing. The state debt amounts to £100,000, but no interest has ever been paid since the loan was made in 1871. English money is current, though accounts are kept in dollars and cents; and English weights and measures prevail. The republic does not enjoy much favour in the eyes of the native Negroes, nor yet of those in the United States, although a few immigrants still continue to arrive from year to year. Not only have the Liberians failed to make any impression on the aboriginal inhabitants, the people they were sent to civilise, but they themselves are relapsing in many respects towards barbarism: they are lazy and quarrelsome, and ape the worse manners of the whites, though there are some honourable exceptions.

See Buttikofer, *Reisbilder aus Liberia* (2 vols. Leyden, 1890); Bourzeix, *La République de Libéria* (Paris, 1887); and Wauwermans, *Libéria* (Brussels, 1885).

Liberius, a native of Rome, succeeded to the see of his native city in 352, on the death of Pope Julius I. For refusing to confirm the decree which condemned Athanasius he was in 355 banished to Thrace by the Emperor Constantius. But three years later he returned to Rome, expelled his rival, Felix II., and re-seated himself on the papal throne. He died on 24th September 366. See **ARIUS**, and **ATHANASIUS**.

Liberty, Equality, Fraternity (*Liberté, Égalité, Fraternité*), the motto of the French Republic, dates from the time of the first revolution. Equality, it should be noted, merely means equality before the law and the absence of class privileges. The motto gives title to a work by Sir J. F. Stephen (1873). For the Cap of Liberty, see **BONNET**. The custom of planting trees of liberty, crowned with a *bonnet rouge*, became common during the Revolution.

Liberty of the Press. See **PRESS**.

Libidibi. See **DIVIDIBI**.

Libourne, a town in the French department of Gironde, at the confluence of the Isle with the tidal Dordogne, 22 miles by rail N.E. of Bordeaux. It is one of the ancient free towns founded by the English, about 1269. Woollens and military clothing are manufactured. Pop. (1872) 12,713; (1891) 14,215.

Libra, the seventh sign of the Zodiac (q.v.).

Library. As soon as men were so far advanced in civilisation as to commit their thoughts to writing in any portable form, whether on papyrus, bricks, parchment, or paper, there were books and consequently libraries. The first of such libraries would probably be the collection of sacred books belonging to the temples of the gods, and under the care of priests. The archives of the state would also be gathered together in the palaces of princes accessible only to a privileged few. But public libraries in the modern sense of the term instituted for the purposes of research in all branches of knowledge—have existed in the most remote

antiquity. As early as 3800 years B.C., according to Professor Sayce, Sargon I., the Semitic ruler of Accad, founded such a library in that city. Here was deposited the great work of Babylonian astronomy, *The Observations of Bel*, which in later acrostichs has come down to our day. The name of the keeper of Sargon's library, Duni sarru, the most ancient librarian on record, is preserved to us on his seal, which is still extant. Libraries of a similar kind were formed in all the chief cities of Babylonia. Their contents, or copies and translations made from them, were finally gathered together to enrich the more famous Assyrian library established in the palace of Koyunjik at Nineveh by Assurbanipal. This great library was rich in history, astronomy, grammar, sacred hymns, and legends, and the science of divination and demonology. The books were on brick tablets, papyrus, and leather. The number of tablets is estimated by M. Menant at about 10,000, making some 500 of our modern volumes of 500 pages in 4to. The greater portion of these tablets, as is well known, have been recovered and deposited in the British Museum. The library of Assurbanipal was intended for the public good. In a note appended to a grammatical treatise the king says: 'I have written it upon tablets . . . I have placed it in my palace for the instruction of my subjects.' The books were methodically arranged and numbered, and the reader requiring a volume handed to the librarian a ticket inscribed with the requisite number.

In ancient Egypt there was an immense literature, and Diodorus Siculus describes the library of King Osymandyas, identified with Rameses I., as having over its door the inscription, 'Dispensary of the Soul.' At a later period the Ptolemies of Egypt vied with the kings of Pergamus in forming magnificent collections. An account of those established in Alexandria has already been given (see **ALEXANDRIAN LIBRARY**). Of the libraries in Greece we know very little. Pisistratus is the most ancient collector named by Greek historians, and Aristotle, who left behind him a large library, is said to have inspired the sovereigns of Egypt with the taste for collecting.

It is characteristic of ancient Rome that the first great libraries of the city should have been formed of the spoils of war. Æmilius Paulus brought to Rome about 168 B.C. the library of the king of Macedonia. Lucullus formed a large collection of books which he liberally threw open to all scholars; but the first public library, properly so called, appears to have been that established by Asinius Pollio, 39 B.C., which he appropriately placed in the temple of Liberty. Julius Caesar intended to erect a public library, but left his design to be carried out by Augustus, who founded two, the Octavian and the Palatine. Other emperors were zealous in adding to the number. The chief of these was the Ulpian Library, instituted by Trajan. At Byzantium Constantine began to collect the Christian books which had escaped the destructive inquisition of Diocletian.

After the irruption of the barbarians the work of building up libraries had to be begun *de novo*. The ravages of fire and war had substantially destroyed the ancient collections. The classical literature was naturally neglected by the Christians, whose own literature had suffered largely from the hostility of the pagans. But the germs of our modern libraries were laid in the cloister. The monks of the order of St Benedict especially were the collectors, translators, and bookmakers of the early middle ages. England may be said in this matter to have led the way. The monasteries of Canterbury, York, Croyland, Whitby, and Durham were at an early date possessed of good libraries. Alenin, when at

Tours, urged Charlemagne, who was zealous in the restoration of learning, to send into Britain for books. Among the more famous libraries abroad may be mentioned those of the monastic communities at Fulda, Corvei, and St Gall in Germany, Monte Cassino in Italy, Fleury and Clugny in France. The books here stored were naturally in large part theological, though the Latin classics were not neglected. A good idea of the contents of such libraries may be gathered from the catalogue of Christ Church, Canterbury, and some other similar lists printed by Edwards in his *Memoirs of Libraries*. It is said that no less than 600 catalogues of monastic collections are preserved in the library of Munich.

The period of decline in monastic learning in Europe generally coincided with the revival of classical studies and of secular literature; and the collecting of books once more became the honourable ambition of princes and private persons. Italy was in this respect especially distinguished. Coluccio, chancellor of Florence, himself a great collector, wrote a treatise urging the establishment of public libraries. Niccolo Nicoli at his death in 1436 bequeathed his library for public use. Following these examples Lorenzo de' Medici formed a magnificent library. Frederick, Duke of Urbino, did the same; and Corvinus, king of Hungary, left at his death in 1490 a collection of 50,000 volumes. Among private collectors, at an earlier date in Great Britain, Richard Aungerville (q.v.), Bishop of Durham, must not be omitted, nor Guy de Beauchamp, Earl of Warwick, who in 1315 bequeathed a collection, chiefly of romances, to Bodlesly Abbey, Worcestershire.

Britain was, however, but slightly touched with the spirit of the literary revival which elsewhere led to the zealous gathering together of the relics of antiquity. The destruction of monasteries and the prejudices of the Reformers led rather to a reckless destruction of books, and the 16th century was a dark age in the library history of the nation. Henry VII. had possessed a collection of three or four hundred choice volumes. Henry VIII., while he was disbursing nearly £11,000 on jewellery, was content to spend £124 on books and binding. Edward VI. did something, Mary and Elizabeth very little, towards increasing the royal library. Archbishop Parker and others made a great effort to induce Queen Elizabeth to form a public library after the pattern 'set us by the more civilised nations, as Germany, Italy, and France,' but without success. The want of a national library continued to be felt for another century and a half. In the reign of William III. the writer of a pamphlet, said to be Richard Bentley, then keeper of the royal library, describes it as having been in a flourishing condition in the time of James I., and since 'fallen into decay to the great dishonour of the crown and the whole nation.' He proposes that there should be a new royal library erected and supported by a yearly revenue settled on it by parliament. The proposal was not carried out, but in 1759 George II. incorporated the library, then containing about 12,000 volumes, with the recently-founded collection of the British Museum (q.v.).

Meanwhile, during the 17th century, many important collegiate and local libraries were founded throughout the kingdom. Sir Thomas Bodley founded the great library which bears his name at the Oxford University in 1602; and while he was ransacking the London bookstalls for his purpose he encountered Archbishop Ussher, who was bent on the same errand on behalf of the newly-established library of Trinity College, Dublin (1601). The Bodleian Library contains over 400,000 printed volumes and 30,000 MSS. The university of Edinburgh, a little later (1627), received a

valuable accession to its collection from Drummond of Hawthornden, and at the close of the century (1682) the Faculty of Advocates entrusted to Sir George Mackenzie the task of building up their library. The university library of Cambridge had been founded in the 15th century, but received a considerable addition by a benefaction of George I. It is now estimated to contain more than 200,000 volumes. In London Archbishop Bameroft founded the Lambeth Library in 1610; and Sion College, a guild of the clergy of London and its suburbs, founded a library in 1629. Good libraries were also established in some of the English towns—Leicester, Norwich, Bristol, and notably Manchester, where Humphrey Chetham in 1653 founded for public use a library which at one time was larger than any out of London and the two university cities. The minor libraries of the several colleges of the universities, and of the Inns of Court, also deserve mention, for, though not always large in number of volumes, they often contain valuable collections on special subjects, manuscripts, rare printed books, and incunabula.

All these libraries, as a rule, possessed little or no endowments, and depended largely for their growth upon private donations. Bodley, however, obtained from the Stationers' Hall in 1610 a grant of all books there entered. By an act of parliament, 14 Chas. II. chap. 33 (1662), printers were ordered to present copies of such books to both universities and the royal library. The Copyright Act of 8 Anne, chap. 20 (1710) required nine copies to be provided for the royal library, then at St James's, the two English universities, the four Scottish universities, the Faculty of Advocates, Edinburgh, and Sion College, London. The privilege attached to the royal library passed with the gift of its books to the British Museum. After the legislative union with Ireland it was extended (41 Geo. III. chap. 107) to the libraries of Trinity College, and the King's Inn, Dublin—thus making in all a tax upon publishers of eleven copies. The number was, however, in 1835 reduced to five; and a yearly grant in compensation was made to the other six libraries, based on a calculation of the average value of the books received by them through the copyright tax during the three preceding years. From this grant Edinburgh University receives £575; Glasgow, £707; St Andrews, £630; Aberdeen, £320; King's Inn, Dublin, £435; and Sion College, £363.

About the middle of the 18th century we hear of the first circulating library established in London. One was opened in Birmingham by Hutton in 1757. About the same time a proprietary library made its appearance in Liverpool. The Leeds library, in the establishment of which Dr Priestley took a prominent part, dates from 1768. It now contains about 80,000 volumes. Great Britain still remained in the early years of the 19th century far behind the rest of Europe in the number and value as well as the accessibility of its libraries. More than three hundred years ago Bishop Bale lamented that there was not in each county at least one library 'for the preservation of noble works, and preferment of good learning.' In the next century John Evelyn declared that Paris alone was able to show more libraries than all the three nations of Great Britain; and, even after the foundation of the British Museum, Gibbon was so little contented with its abundance that he recorded his opinion that 'the greatest city in the world is still destitute of a public library.' But in the middle of the 19th century interest in the subject was awakened, and a great movement took place in the direction of extending and popularising libraries. While a royal commission was enquiring into the management of the British Museum, in 1849 a select committee, on the

motion of William Ewart, M.P. for Dumfries, was appointed by the House of Commons to report on the best means of 'extending the establishment of libraries freely open to the public, especially in large towns in Great Britain and Ireland.' Before this committee was laid a map of Europe (printed in the report) exhibiting by various shades the relative provision of books, in libraries publicly accessible, as compared with the population of the several countries. On this map the smaller German states are represented by the lightest lines, indicating the richest supply, and Great Britain with the darkest shade or poorest provision. The statistics furnished in illustration showed that in Saxony for every hundred inhabitants there were 47 books; in Denmark, 412; in Bavaria, 359; in Tuscany, 261; in Prussia, 200; in Austria, 167; in France, 129; in Belgium, 95; while in Great Britain there were only 53 books to every hundred inhabitants. It may be remarked that in 1850 the British Museum in point of magnitude stood fourth in the list of European libraries. It now holds the second place. The following table shows the increase of the European libraries at that time containing over 400,000 volumes in the course of the next thirty-one years:

	1850.	1881.
Paris, National Library.....	524,000	1,257,000
Munich, Royal Library.....	600,000	1,026,000
St. Petersburg, Imperial Library.....	446,000	1,026,000
London, British Museum.....	435,000	1,550,000
Copenhagen, Royal Library.....	412,000	490,000
Berlin, Royal Library.....	410,000	766,000

Mr Ewart's bill, giving power to certain districts to establish free libraries and to tax the inhabitants for that purpose, passed into law in 1850, and has since been supplemented, amended, and extended to Ireland and Scotland by the acts of 1855, 1866, 1871, 1877, 1884, 1887, and 1889. It is applicable to any borough, district, or parish, whatever the amount of population; a meeting of the rate-payers may be obtained by the requisition of ten of their number addressed to the town-council or other local board, and the adoption of the act is decided by a majority of those present at the meeting, or, if the local authorities prefer it, the will of the majority may be obtained by the issue of voting papers, instead of the convening of a public meeting. All such libraries are to be open to the public free of charge. Some of the larger towns at once took advantage of the act. Manchester led the way in 1852. The libraries of Liverpool and Birmingham were opened in 1860. Each of these libraries now contains more than 100,000 volumes. Yet the movement did not become general for many years. In 1868 there were only fourteen libraries established under the acts. Ten years later the number had increased to eighty-one. A complete list of places where the acts have been adopted, with the dates of their adoption, furnished by Mr Greenwood in his 'Public Libraries,' brings the number in June 1890 up to 208. Before 1886 there were only two parishes in London provided with free libraries. In 1890 there were twenty-one established within the boundaries of the metropolis.

The English act was extended to Scotland in 1854, and the first town to profit by it was Airdrie. The free library of Dundee was founded in 1866, and has 70,000 volumes, spending annually £1000. Edinburgh was comparatively rich in libraries belonging to professional bodies and learned societies, and was slow to adopt the acts. There is in Edinburgh or elsewhere in Scotland no national library supported by the exchequer as in Ireland; but the Advocates' Library, now counting 320,000 volumes, being liberally thrown open to all students, served many of the purposes of such a library; and the Signet Library, a general collec-

tion as well as a legal library (82,000 vols. in all), founded and maintained by the Society of Writers to H.M. Signet, was easy of access to strangers. The university library contains 180,000 volumes. In 1886, however, the city was persuaded by the munificent donation of Mr Andrew Carnegie to establish the Free Public Library, which was opened with 50,000 volumes in June 1890. Glasgow is still without a library under the acts, but the deficiency is in small part supplied by the Mitchell Library, founded by a bequest of the late Stephen Mitchell, and opened in 1877. This library, which has rapidly grown and is specially rich in local literature and Scottish poetry, now contains over 80,000 volumes. It is open to all persons over fourteen years of age.

In Dublin the library of Trinity College retains the copyright privilege, and has 223,000 volumes. The King's Inn library, founded in 1787, which, as has been said, had the copyright tax commuted for an annual sum, is comparatively small (60,000), and restricted to members of the legal profession. The National Library of Ireland, established in Dublin in 1877, and transferred to a new building in 1890, was formed in part by the collection of the Royal Dublin Society, and now numbers 100,000 volumes. It was placed under the Science and Art Department of South Kensington, and is in receipt of an annual grant of £1000 for the purchase of books.

France is remarkable for the number and excellence of its provincial libraries open to the public, while its capital is better provided than any other city in Europe. The Bibliothèque Nationale, which is the largest in the world, is of ancient origin, and contains the collections of many French kings. Its modern history may be said to date from the librarianship of De Thou. In 1617 it obtained the right of two copies of every book published in the kingdom, and at the end of the century it was thrown open to the public. At the beginning of the 19th century it contained 250,000 printed books, 83,000 MSS., and 1,500,000 engravings. The Revolution enriched it with many forfeited collections of private persons and religious communities; and Napoleon augmented the government grant for purchases. The number of its volumes is now well over three million. Fourteen other libraries, most of which are open to the public, and to all of which access can be obtained without difficulty, add about 1,200,000 to the number of volumes available to the Parisian reader. There are, moreover, a number of municipal libraries in the city. The most notable provincial libraries, from many of which books are lent out, are—taking them in the order of magnitude—those of Bourdeaux, Grenoble, Aix, Nantes, Besançon, Rouen, Troyes, and Douai; the first numbering 300,000 volumes, and the last over 100,000. An important feature of the bibliothecal system of France is the school library. In 1862 it was ordered that to every primary school in the country there should be attached a library, under the care of the schoolmaster, for the use of the children, their parents, and others. They are supported partly by the department and partly by a government grant. In 1882 there were already established under this system 20,000 of these school libraries.

Throughout the German empire the several state libraries and the universities are well provided with books, which in many cases can be borrowed for use outside the libraries. Berlin has over seventy libraries. The royal library, founded in 1659, was opened to the public in 1661. A few years later it became entitled to a copy of every book published within the royal dominion, and it spends £4800 a year on purchases. It now contains about 800,000 volumes. The royal library at Munich owes its origin to Albert V., Duke of Bavaria, in

the middle of the 16th century. It is the largest collection in Germany, and is particularly rich in incunabula. The number of printed volumes contained in it is estimated to exceed a million, and it possesses some 26,000 MSS. In Dresden there are forty-nine libraries. The royal library, founded in the 16th century, now contains 500,000 volumes. About 10,000 volumes are annually lent out to 500 borrowers. The royal library of Stuttgart is an example of rapid growth. It was established in 1765, and in 1880 boasted of possessing about 425,000 printed books and 3800 MSS. It enjoys the copy privilege of Württemberg. The annual number of borrowers is about 1800, and the books lent out 17,000. In the Darmstadt library there are half-a-million volumes, and as many in the university of Leipzig. The universities of Bonn, Berlin, Breslau, Göttingen, Halle, Heidelberg, Munich, Tübingen, and Würzburg contain from 200,000 to 400,000 volumes each; while Strasburg University library, burned in 1870, in twenty years' time counted 640,000.

In Austria-Hungary the universities of Cracow and Gratz, both open to the public, contain over 100,000 volumes, and that of Budapest nearly half-a-million. In Vienna the imperial library, founded by the Emperor Frederick III. in 1449, acquired a large portion of the famous library of Corvinus, and since 1808 has been entitled to the copy privilege of all books published within the empire. It is estimated to contain about 500,000 volumes, of which 20,000 are MSS. The university in the same city is also in possession of the copy privilege, and has about 300,000 volumes, which are freely lent out. Altogether there are in Vienna more than a hundred libraries.

Italy, as might be expected, is rich in old libraries, in incunabula, and manuscripts. The national library of Florence has over 400,000 volumes, the national library of Milan has 300,000, and that of Venice has the same. The royal library of Parma has nearly 200,000, and Milan possesses two libraries with as many. The universities of Bologna, Genoa, Naples, Pisa, and Turin have libraries of the first class. But all these yield in interest to the Vatican Library at Rome, which is probably the oldest in Europe. In mere number of books it is exceeded by many, but its 220,000 printed volumes are of the greatest value, and its 25,000 MSS. include some of the most precious in the world. The Vatican is the private library of the pope, but scholars can gain access to it by permission. As yet, unfortunately, the want of catalogues is a drawback to its usefulness. In Rome, also, the public library, Vittorio Emanuele, to which has been joined the Bibliotheca Casanatense, founded by Cardinal Casanata in 1700, was made up in great part from the old Jesuit library of the Collegio Romano and other suppressed religious institutions, and now contains about half-a-million printed volumes and 7500 MSS. The confiscated monastic libraries helped largely to swell the aggregate number of volumes available for public use. In 1875 it appears that 650 of these collections were added to the contents of public libraries already in existence, while as many as 1050 were used for the formation of more than 400 new communal libraries. In Italy all the public libraries, thirty-two in number, including the national libraries, the university libraries, and the collections of certain academies, are under the authority of the minister of Public Instruction, and their internal management, even to the compilation of their catalogues, the keeping of registers, and the purchase of books, is regulated by a code of rules emanating from the state.

In Spain the national library at Madrid is of the

largest class, with 10,000 MSS. and more than 400,000 printed volumes. It enjoys the copyright privilege for all books published in the kingdom. The Escorial, though much smaller, is valuable, and the same may be said of the university library of Salamanca. The national library of Lisbon has as many MSS. as that of Madrid, and half as many printed books. The large municipal library of Oporto, founded in 1833, was enriched by the collections of suppressed religious houses. Both these libraries claim copies of all books published in Portugal.

In Belgium there are ten large libraries open to the public. The Bibliothèque Royale at Brussels (with which were incorporated the ancient library of the dukes of Burgundy and a large part of the Bollandists' collection) contains more than 350,000 volumes, 30,000 MSS., and 100,000 prints. The privilege of copyright is accorded to publishers only on the condition of their presenting copies of their publication to this library. The university libraries of Ghent and Louvain contain over 250,000 volumes, and that of Liège more than 100,000.

In Holland there are libraries, open to all inquirers, containing from 100,000 to more than double that number in Amsterdam, the Hague (royal library), Leyden, and Utrecht.

In Denmark the royal library of Copenhagen, begun in the middle of the 16th century, has more than half-a-million of volumes, including a rich collection of incunabula and 18,000 MSS. It was opened to the public in 1793, and exacts two copies of all books published in the kingdom. The university library in the same city has about 250,000 printed volumes and 4000 MSS., and also enjoys the privilege of the national copy tax.

The largest collection in Sweden is the royal library of Stockholm, with about 270,000 volumes. The university library of Upsala is not far behind. The university library of Christiania, in Norway, contains about 250,000 volumes.

In Russia the universities of Dorpat, Helsingfors, Kiell, Moscow, and St Petersburg have libraries of more than 100,000 volumes each, but they are not generally open to other than members of the several bodies. The imperial library at St Petersburg, founded at the beginning of the 18th century, is, however, open to all persons over twelve years of age, and in the number of its printed books as well as manuscripts it surpasses the royal library of Munich, possessing as it does about 1,152,000 printed volumes and about 26,000 MSS., some of which are of the highest value. Here is preserved the famous Codex Sinaiticus. This library has grown largely since the beginning of the 19th century. It has more than doubled since 1850. In 1810 the law required two copies of every publication in the empire to be deposited here.

The United States of America have not had the opportunities of Europe in the gradual accumulation of princely collections in the course of centuries, or the advantages possessed by France or Italy in the more recent appropriation of the books and treasures of monastic houses. Moreover, the States, until 1850, showed comparatively little interest in the institution of public libraries outside the universities. In that year the total number of libraries containing 5000 volumes or upwards which could be said to be accessible to the public was estimated at eighty-one, containing among them an aggregate of 980,413 volumes—considerably less than the total number of volumes to be found in the single city of Paris. The movement in favour of free public libraries took place in America about the same time as in England, and since that date nowhere has the accumulation of books been so rapid as in the States, and nowhere has the economy and management of free public libraries

been carried to greater perfection. In 1876 the number of public libraries registered was 3842, containing upwards of 12,569,000 volumes. In the middle of the century there was no library in the States with as many as 75,000 volumes. In 1890 there were at least a dozen with over 100,000. Among the older collections the most notable is that of Harvard University, established in 1638. In 1850 it was estimated to contain in all 72,000 volumes. The number has now risen to more than 250,000, and it increases at the rate of 7000 volumes annually. Yale College, New Haven, which had in 1850 some 21,000 volumes, now has about 180,000. Official libraries have been formed in connection with every state, to which admission is free. The largest of these is the library of the state of New York at Albany, numbering about 140,000 volumes. The library of congress at Washington, which includes the scientific collection of the Smithsonian Institution, is the national library of the United States. It claims, under the copyright laws, two copies of every publication, and has in addition an annual grant from congress of nearly \$60,000. The building now in course of erection will when completed be the largest national library in any country. Of the free town libraries the most important is that of Boston, founded in 1852. In 1881 it had 395,000 volumes, and now has 620,000. In Pennsylvania there are 433 libraries, with a gross total of about two million volumes. Other great libraries have been established and endowed for public use by the munificence of private individuals. The Astor Library at New York, founded by Jacob Astor and augmented by his son and grandson, was opened in 1854, and was able to spend on books \$18,000 a year. The Lenox Library, also at New York, was established in 1870 by Mr James Lenox, who left an endowment of over a million dollars. The Astor, Lenox, and Tilden Libraries were incorporated by a law of 1895 into one having 4,000,000 volumes and an endowment of \$8,000,000. Another notable donation was the Newberry bequest, which became available in 1885, of more than two million dollars for the establishment of a free public library in the north division of Chicago.

In Canada, as yet, there are but few public libraries. That of Toronto, established in 1883, has, however, been a marked success. It now contains about 58,000 volumes. The library of parliament at Ottawa, founded in 1815, has over 100,000 volumes. In Australasia the library movement is striking deeper root. It was calculated in 1887 that there was a public library in Victoria for every 4800 of the inhabitants, as against one for every 277,000 in the United Kingdom. There are in Victoria 425 libraries. The Melbourne public library, founded in 1853, has by the Copyright Act of Victoria privileges like those possessed by the British Museum, and contains 430,000 volumes, pamphlets, and parts. In South Australia there are 140 public libraries, and in New South Wales 160. In 1896 there were in New Zealand 304, and in Tasmania 40 libraries.

The literature of the subject is a large one. Monographs have been written on the principal libraries, ancient and modern; and reports on the national libraries have been issued from time to time by the governments of France, Italy, United States, &c. The most complete general history will be found in the valuable series of works by Mr Edwards, already referred to, *Memoirs of Libraries* (2 vols. 8vo, 1859), *Libraries and Founders of Libraries* (1865), *Free Town Libraries* (1869); and *Free Public Libraries*, by T. Greenwood (3d ed. Lond. 1890). See also the Report from the Select Committee on Public Libraries (1849, 357 pp. fol.); an international list of libraries (Leip. 1890), by P. E. Richter; *How to Form a Library*, by H. B. Wheatley (1886); *The Library*, by A. Lang (1888); G. F. Chambers, *Digest of*

the Laws of Public Libraries (1889); the little treatise of Mr J. D. Mullins on *Free Libraries and News Rooms*. On the subject of library management and cognate subjects much practical information will be found in the volumes of *The Library Journal* (1876 to the present time), New York; the *Transactions and Proceedings of the Library Association of the United Kingdom*, and in *The Librarian*, the present organ of the association, edited by Mr M'Alister. Petzholdt's *Katechismus der Bibliothekentehrer* will be found a useful hand-book. Compare also the articles BIBLIOGRAPHY, BOOKS, BOOK-BINDING, INDEXING, &c.

Libration (from Lat. *libra*, 'a balance,' meaning an oscillating motion), a term denoting certain movements of the moon, chiefly *apparent*, which have an important effect on the apparent position of the lunar formations. A short study of these reveals puzzling changes in their place from night to night. Those near the edge of the disc disappear and reappear in a seemingly irregular way, while central formations approach or leave the centre in harmony with this motion. These appearances are due to an apparent motion of the moon by which its globe seems to turn slightly round to each side alternately, so that we see a little farther round her globe on all sides in turn than we would do if she kept absolutely the same face towards us. This motion, as it refers to the north and south edges of the moon's disc, is called *libration in latitude*; as it refers to the east and west edges, it is called *libration in longitude*. The libration in latitude arises from the inclination of both the lunar equator and orbit to the ecliptic. From the relation between these two factors their effects always reinforce each other, so that when the moon rises above the ecliptic in her orbit she also inclines her under side to us, and when below the ecliptic, her upper side. The libration in longitude arises from the unequal speed of the moon in her orbit (see MOON) combined with her sensibly uniform rotation. She is thus sometimes before or behind her mean place, and we can see a little round her west or east edge respectively. An observer at the north or south pole of the earth will also from his position see a little round the north or south edge of the moon's disc, and for intermediate positions the effect has intermediate values. In the same way an observer in the tropics will see further round the west or east edges of the moon, as he is carried from west to east by the earth's rotation. These effects are known as the *diurnal* or *parallaxic* libration. The maximum libration in longitude is nearly 6° 50'. That in latitude equals 7° 53'. The diurnal libration may rise to 1° 2'. These numbers refer to the apparent displacement of lunar markings in lunar latitude and longitude.

Libretto (Ital. 'little book'), the book of an opera. In too many cases it is deplorable, from the absence of any literary quality, plot, or consistency; and this largely because, almost from the beginning, any poetic or dramatic powers were forced into the Procrustes' bed formed by the requirements of the musician's art. The Italian librettos are especially poor, but many of their English and German rivals run them hard in this respect. Among the most noteworthy librettists have been Metastasio, Calzabigi, and Felice Romano in Italy; Quinault, Marmontel, Scribe, Barbier, Méilhac and Halevy, as well as Sardou, in France; the poet Göbel (who wrote *Lorchy* for Mendelssohn) and Schikaneder (who wrote the *Zauberflöte*, &c. for Mozart) in Germany; and Gay, Alfred Bunn, Edward Fitzball, Theodore Hook, Planché, and Gilbert in England. Wagner stands alone, in that, after the *Flying Dutchman*, he himself wrote the librettos of his great music-dramas, becoming, to use his own words, 'first of all a poet.' Dryden, Addison, Fielding, Chat-

terton, 'Monk' Lewis, Voltaire, and Rousseau, besides Sheridan, Dickens, and Mark Lemon, have attempted libretto-writing; while numerous subjects for operas have been taken from the works of Shakespeare, Goldsmith, Goethe, Scott, Hugo, &c.

Libri-Carrucci. GUILLAUME BRUTTI'S ILLIUS TIMOLLO, COUNT, mathematician and bibliographer, was born at Florence, 2d January 1803. When only twenty years of age he was appointed professor of Mathematics in the university of Pisa. But in 1830, being compromised in the Liberal political movement, he fled to France as a refugee, and there found a patron in Arago (whom he afterwards attacked in a most spiteful manner). He was naturalised, and in 1833 elected member of the Academy of Sciences, professor at the Sorbonne, Chief Inspector of Public Instruction, and Superintendent of the State Libraries. He was, moreover, decorated with the Legion of Honour, and appointed editor of the *Journal des Savants*, &c. An enthusiastic bibliomaniac, he found means to collect a magnificent library for himself; but, being accused of abstracting books and valuable MSS. from the public libraries, he fled to England. In his absence he was tried, and condemned, in June 1850, to ten years' imprisonment. Libri-Carrucci was the author of a learned *Histoire des Sciences Mathématiques en Italie* (4 vols, 1838-41), of *Mémoires de Mathématiques et de Physique* (1829), and other works. He died on 28th September 1869 at Fiesole in Italy.

Libris. EX. See BOOKPLATES.

Libya, the name given by the ancient geographers to that portion of Africa (q.v.) between Egypt, Ethiopia, and the Atlantic.

Lice (*Pediculidae*), a family of small, wingless, parasitic insects, included beside bugs, aphides, Coccidae, &c. in the order Hemiptera or Rhynchota. The body is flat, the legs are short and furnished with firmly-grasping claws, the mouth is suctorial, the eyes are simple. They live on or partly in the skin of vertebrates, usually mammals, and suck the blood of their hosts. The pear-shaped eggs or 'nits' are attached to hairs, feathers, and the like; the young have no metamorphosis, though they may moult as usual. Three species occur on man. The head-louse (*Pediculus capitis*) occurs on the scalp; the body-louse (*P. vestimenti*) lays its eggs in clothes, and is the *P. tuberculatum* of the 'lousy disease' in regard to which many fabulous reports are on record. Both multiply rapidly and give



Pediculus capitis, magnified.

great annoyance, usually preventable by cleanliness, and removable by various (e.g. white precipitate) ointments in the first case, by destroying the clothes, in the second. The 'crab louse' (*Phthirus pubis* or *inguinalis*) is fortunately rarer; it occurs on various parts of the body—pubic regions, axilla, eyebrows, &c. The true lice harboured by dogs, horses, cattle, swine, &c. are referred to the genus *Hemantropinus*. The 'bird lice' (Mallophaga) have mouths adapted for biting, and are not included in the above family or even order, being more nearly allied to the termites than to the bugs. A common and large genus infesting birds is *Phleboterus*; species of *Trichodectes* occur on dogs and sheep.

License. See GAME, DOG, MARRIAGE, EXCISE, &c.

Licensing Laws. From an early period the English parliament devoted special attention to the trade in intoxicating liquors. That trade was

always the chief source of the revenue derived from excise duties and licenses. A general scheme of excise formed part of Pitt's budget of 1784, and was embodied in the Consolidation Act of 1826, which is the basis of the existing law. In 1880 the malt duty was abolished; but brewers and distillers are still required to take out an excise license and to pay duty according to the quantity manufactured. Wholesale or retail dealers in beer, spirits, or wine must also take out a license. The duties on retailers' licenses were transferred to the county councils by the Local Government Act of 1888.

In the case of the manufacturer and the wholesale dealer only the excise license is required; but the retail trade in liquor has been placed, for more than three centuries, under the supervision of the justices of the peace. Every person who keeps or intends to keep a public-house must obtain a license from the magistrates before taking out his excise license. An act of 1830 permitted beer licenses to be taken out without applying to the magistrates; but later acts have brought all beer-houses and refreshment-houses under their control. Under the general Licensing Act of 1828 special sessions are held once a year for the grant and renewal of licenses, and at intervals throughout the year to hear applications for transfer. In counties new licenses are granted by the special sessions, but they must be confirmed by a committee of the county justices. In boroughs having ten or more acting justices, new licenses are granted by a committee and confirmed by the whole body of justices. The license thus granted and confirmed is in force for a year. On applying for a renewal the applicant need not attend in person unless required by the justices to do so; objectors are not heard unless due notice has been given to the applicant, and evidence must be given on oath. Magistrates in licensing sessions are deemed to be acting judicially; they must hear the parties fairly; but they have discretion to grant or refuse any application, and there is no appeal from their decision on the application for a new license. Even a license-holder cannot claim renewal as a right; he has no vested interest. But renewal is, in fact, very seldom refused to persons of decent character, occupying suitable premises; and the practice of the magistrates has made license-holders so far secure that a license is treated, for certain purposes, as if it were a vested interest. Probate duty is paid on the value of a license held by a deceased person; but his representatives may obtain a return of the duty if the magistrates refuse to renew. Licenses for the sale of drink to be consumed off the premises are subject to rules less strict than those which apply to the publican's license. The 'off license' requires no confirmation; and the grounds on which it may be refused are limited and defined by the Wine and Beerhouse Act of 1869. For the detailed provisions of the acts relating to this subject, see Stone's *Justices' Manual*.

The English licensing acts are complicated and confused; but parliament is unable to deal with the subject as a whole, by reason of the controversies which have been raised on particular points. There are now very few advocates of 'free trade in liquor'; nor is there any strong body of opinion in favour of the American high-license system, or of the 'Gothenburg system,' under which the municipalities would take over the liquor shops and manage them in the interest of the community. In England all parties seem to admit that the trade must be restricted as far as possible. Mr Bruce's Act of 1872 (modified in some of its details by the Act of 1874) restricted the issue of new licenses, subjected the publican's trade to stricter supervision, increased the penalties for misconduct,

and shortened the hours within which liquor may be sold. Since the passing of the Act of 1872 no very important change has been made in the law; but the temperance party has put forward various schemes of local option, by which it is proposed to enable a majority of the ratepayers in a district to reduce the number of licensed houses, or even to prohibit the sale of liquor altogether. In 1890 the government proposed to arm the county councils with powers which might have enabled them to reduce the number of public-houses. But the scheme of compensation put forward by the government was so ill received that they were compelled to drop their proposals.

In Scotland the licensing arrangements introduced by the Home Drummmond Act of 1828 bear a general resemblance to those which were established by the English act of the same year. The Forbes Mackenzie Act of 1853 introduced a new form of magistrates' certificate (since amended by acts of 1862 and 1887), the effect of which is to prohibit the sale of liquor between the hours of 11 P.M. in large towns, or 10 P.M. in the country, and 8 A.M., and during the whole of Sunday. The question of grocers' licenses has been much discussed in Scotland, and in 1878 a Royal Commission reported on the subject. See Dewar's *Liquor Laws for Scotland*.

In Ireland licensing authority is exercised, as a general rule, by justices of the peace, and the law is similar to that of England; it is, however, in some points more favourable to the publican. The defects of the law and the laxity with which it is administered have led to the multiplication of licensed houses of an inferior character. 'Six-day licenses' were introduced by an act of 1874; and in 1878 total closing on Sunday was made part of the law for all Ireland, except in the five largest towns in the island. See EXCISE, INN, TEMPERANCE; and for restrictive legislation with regard to the sale of intoxicating drinks in the British colonies and in portions of the United States, see LIQUOR LAWS.

Licentiate, one of the old university Degrees (q.v.). Among Presbyterians a licentiate is a person licensed or authorised by a presbytery to preach, and who thus becomes eligible to a pastoral charge.

Lichen, the name of a group of skin diseases, very variously employed by different writers, but now generally restricted to cases characterised by 'the development of solid persistent papules which undergo but little change till they gradually disappear.' The commoner skin eruptions formerly called lichen, *L. simplex* and *L. tropicus* (or 'prickly-heat'), are abortive forms of eczema. None of those retained under this name is common. *L. circumscriptus* occurs in bright red patches on the back or front of the chest in adults, apparently from the irritation of thick woollen garments worn next the skin. *L. scrofulosorum* is a pale, very chronic papular eruption, sometimes seen in delicate children. *L. planus* or *ruber* is the most characteristic and important of the group; it manifests itself in raised flat patches, of a dull-red colour, usually very chronic in their course, often somewhat itchy. It does not usually interfere much with the health; occurs generally in adults, never in young children; and commonly yields to treatment by arsenic.

Lichenin is a starch-like body found in Iceland moss and other lichens, from which it is extracted by digesting the moss in a cold, weak solution of carbonate of soda for some time, and then boiling. In most of its relations it corresponds with ordinary starch.

Lichens, familiar plants which form encrusting growths on rocks and stones, on the stems and branches of trees, on walls and fences, and on the

earth itself. They are common in every zone, and at all levels from the seashore to the mountain summit. Usually the first plants to settle on a bare, stony surface, they slowly hide the nakedness of the rock with their flat incrustations or shaggy tufts, generally gray or greenish, yellow or red in colour. Especially familiar are the yellow patches which beautify old walls, the hoary tufts which grace decaying trees, and the gray clumps which raise their cup-like fructifications on damp rocks. They are hardy, long-lived plants, able to survive prolonged desiccation.

In 1866 De Bary hinted that lichens were not single plants in a class by themselves, but that they were double plants, each made up of an intimate combination of an alga and a fungus.

Two years later Schwendener virtually established this so-called 'dual hypothesis.' 'As the result of my researches,' he says, 'all these growths (lichens) are not simple plants, not individuals in the ordinary sense of the word; they are rather colonies, consisting of hundreds and thousands of individuals, among which, however, one dominates, while the rest in perpetual captivity prepare the nutriment for them-

selves and their master. This master is a fungus, a parasite which is accustomed to live upon others' work; its slaves are green algae, which it has sought out, or indeed caught hold of and compelled into its service. It surrounds them, as a spider its prey, with a fibrous net of narrow meshes, which is gradually converted into an impenetrable covering; but, while the spider sucks its prey and leaves it dead, the fungus incites the algae found in its net to more rapid activity, indeed to more vigorous increase.' This view has been corroborated by many botanists, especially by

Bornet, Treub, Rees, and Stahl, and is accepted by most, though it is only fair to say that it is still denied and resented by some distinguished lichenologists.

The proof of the theory is twofold; the two component sets of cells have

been studied apart and referred to their position among Algae and Fungi; while, on the other hand, it is possible to manufacture lichens by bringing together the respective algae and fungi which in



Fig. 1.—*Usnea barbata*, a fruticose lichen, natural size: *a*, fructifications; *f*, disc by which it is attached to the bark of the tree.

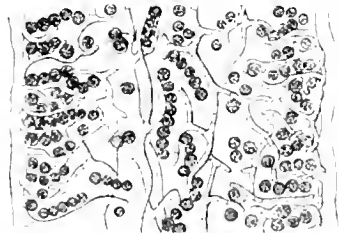

Fig. 2.—Section through *Caloboma polyporum*, magnified 350 diameters: The threads are the fungus; the round cells the alga.

nature are wont to grow in partnership. For these reasons lichens are regarded not as single, but as double organisms—as an intimate union of algal and fungal cells, living in mutual helpfulness or *symbiosis*. Some at least of the algal cells can live apart, and some become associated with several fungi to form different lichens; but it must be clearly recognised that the customary combinations are of long standing, since the partner fungi do not and cannot live independently. As to the physiological conditions of the partnership, it is enough here to notice that root-like filaments from the fungal cells absorb water and salts from the rain and the substratum, and pass this inorganic material to the algae; that the latter, like all green plants, are able in sunlight to split up the carbonic acid absorbed from the air, and to build up organic compounds like starch; that these organic products pass by osmosis from the algal-cells to the fungus, while it is likely enough that the waste products of the fungus are in turn utilised by the alga. (It is, however, quite probable that the fungi of some lichens in favourable situations among decomposing vegetable matter absorb this in the usual fungal fashion.) To the curious complementary association of fungi and algae to form lichens, a parallel has been demonstrated by Geddes, Brandt, and others, in regard to Radiolarians and some other animals, with which 'yellow cells,' or 'symbiotic algae,' live in habitual partnership (see SYMBIOSIS). Lichens propagate by spores developed in various ways from the component fungus, but with these the partner algae must be speedily associated. In some cases, indeed, fungal-spores and algal-cells are liberated together. Another frequent mode of multiplication is by means of brood-buds, which consist of a few algal-cells plus a separated portion of the fungus.

Most of the lichen-forming fungi are Discomycetes or Pyrenomycetes; the associated algae are very varied—e.g. Palmellaceae, Charolepideae, Nostocaceae, Confervaceae, &c. There are about 6000 species of lichens; for the classification of which reference must be made to the cited literature.

Lichens assist in weathering the surfaces of rocks, into the substance of which the fungi sometimes send numerous filaments, and they are thus the preparers of soil and the forerunners of higher vegetation. 'Iceland Moss' (*Cetraria islandica*) is used for food and medicine; 'Reindeer Moss' (*Cladonia rangiferina*) is the fodder of the reindeer, and is also utilised in Scandinavia for the manufacture of a sort of brandy; pigments known as Litmus, Orseille, &c. are procured from *Roccella tinctoria* and *R. furiformis*, both marine.

See ALGAE, FUNGI, SYMBIOSIS. See also De Bary, *Comparative Morphology of Fungi*, &c. (trans. 1887); A. W. Bennett and G. Murray, *Handbook of Cryptogamic Botany* (1889); Bornet, *Recherches sur les Groupes des Lichens* (Ann. Sc. Nat. xvii. and xix. 1873-75); K. Goebel, *Outlines of Classif. and Morph.* (trans. 1887); Ch. Luerssen, *Met. Phara. Botanik* (1878); Schwendener, *Die Algenwelt u. Flechtengruppe* (1869); Sachs, *Textbook of Botany* (trans. 1882); Stahl, *Betr. z. Entwicklung d. Flechten* (1877-78); W. A. Leighton, *Lichen-flora of Great Britain and Ireland* (3d ed. 1884). For the works of Johow, Rees, Treub, Takasue, and for the systematic works on lichenology, see references in the above. For a protest against the 'dual hypothesis,' see M. C. Cooke, *British Fresh-water Algae* (Inter. Sc. Series, 1890).

Lichfield, a municipal (and till 1885 parliamentary) borough of Staffordshire, and the seat of a bishopric, is pleasantly situated in a valley watered by an affluent of the Trent, 15 miles S.E. of Stafford and 118 N.W. of London. Population (1801) 4712; (1881) 8349. Its cathedral—a noble pile, measuring 411 feet by 66 (or 149 across the transepts), and surmounted by three towers with

spires, the central 258 feet high—dates from the 13th century, when the Mercian see, founded in 656, and constituted an archbishopric 786-800, was after its translation to Chester in 1075, and subsequently thence to Coventry, re-established here at its original seat. Despoiled, and with its central tower beaten down during the siege of Lichfield by the parliamentarians (1643), the cathedral was subsequently (1661-70) effectively repaired, and of late years (1860-84) both the exterior and interior have been most ably restored at a cost exceeding £40,000, whilst in 1885 a statue of Queen Victoria by the Princess Louise was placed in a niche of the building. At the north-east angle of the Close, adjoining the cathedral, is the Bishop's Palace (1687), and hard by once stood the castle (of which no traces now remain) in which Richard II. held high revelry at Christmas 1397, and where two years later, after his deposition from the throne, he was confined a prisoner. Amongst other edifices may be noted the grammar-school, at which Addison, Dr Johnson, and Garrick were educated; two hospitals founded 1495 and 1504; the theological college (1857); and a concert hall occupying the site of the theatre at which Mrs Siddons made her first appearance after her marriage. In the history of the town the principal incidents, other than those noticed above, have been its partial destruction by fire (1291); five visitations of the plague, which in 1594 claimed 1100 victims, and 821 in 1645-46; a great storm (1593) which blew down the steeples of two of its churches; and seven royal visits. Its 87 bishops include St Chad, De Clinton (who commenced the cathedral), De Langton (who added the Lady Chapel, now thrown into the choir, and rich in stained glass brought in 1802 from the dissolved monastery of Herkenrode in Belgium), Abbot, afterwards Archbishop of Canterbury; Hacket (who carried out the restorations of 1661-70), Hurd (the tutor of George IV.), and George Augustus Selwyn. A statue of Dr Johnson was erected in 1838 in the market-place, opposite the house in which he was born, and which was bought by a Mr Johnson in 1887 'to save it from the hands of spoilers' (*Notes and Queries*, November 19, 1887). Among residents or natives have been Ashmole (founder of the Ashmolean Museum at Oxford), Bishop Newton, Dr Darwin, and his biographer Miss Seward, and Honora Sneyd, afterwards Mrs Edgeworth. Lichfield gives the title of Earl to the family of Anson. See Harwood's *Lichfield* (1806), Erleswick's *Staffordshire* (revised ed. 1844), and Beresford's *Lichfield* ('Diocesan Histories' series, 1883).

Lichtenberg, GEORG CHRISTOPH, physicist and satirist, was born on 1st July 1742, at Oberramstadt near Darmstadt, and educated at Göttingen, where he held the chair of Mathematics from 1770 till within a few years of his death, on 24th February 1799. Two visits to England (1769 and 1774) inspired him with a love for things English; he had a great admiration for Garrick, and wrote a witty commentary on Hogarth's copperplates, *Ausführliche Erklärung der Hogarth'schen Kupferstiche* (1791 et seq.). In Germany he enjoys a high reputation as a satirist, Lavater being an especial sufferer at his hands. All his writings were desultory and occasional, and mostly semi-philosophical in spirit; they show a keen insight into human nature. The best collected edition is that by his sons, 14 vols. 1841-53. See Grisebach's *Gedanken und Maximen aus Lichtenbergs Schriften* (with biography, 1871), and Meyer's comparative study of Swift and Lichtenberg (1886).

Lichtenstein, a town of Saxony, on the Röd-litz, 45 miles S.E. of Leipzig. Pop. 5395. See also LICHTENSTEIN.

Lick Observatory is built on the lowest (4227 feet) of the three summits of Mount Hamilton, 26 miles by a fine mountain-road E. of San Jose, California. For its erection and equipment \$700,000 were left by James Lick (1796-1876), an American millionaire, whose remains are interred in a vault within the foundations of the pier that supports the great telescope. This instrument has an object-glass of 36 inches in aperture, the founder requiring it to be 'superior to and more powerful than any telescope ever yet made;' and it is provided with a photographic attachment which enables it to be used as a gigantic camera in the photography of stars. When completed the observatory was made over to the University of California. See Professor Holden's *Handbook of the Lick Observatory* (San Francisco, 1888).

Lictors. See CONSUL, FASCES.

Liddell, HENRY GEORGE, joint author of *Liddell and Scott's Greek Lexicon*, was born in 1811, and educated at Charterhouse and Christ Church, Oxford, where he took a double first in 1833. He was made tutor of his college, and in 1845 professor of Moral Philosophy in his university. After acting for nine years (1846-55) as head-master of Westminster School, he returned to Christ Church as dean. From 1870 to 1874 he was vice-chancellor of the university. The *Lexicon* (1843; 7th and definitive ed. 1883) was based on the German one of Passow. It soon became indispensable to students of Greek, and a smaller edition was issued for the use of school-boys, an intermediate one in 1890. Dr Liddell's fellow-worker was Robert Scott, D.D. (1811-87), master of Balliol (1854-70), and Dean of Rochester. Dr Liddell wrote a useful *History of Rome* (1855; abridged as *The Student's Rome*). He resigned the deanship in 1891, and died 18th January 1898. See Life by Thompson (1899).

Liddesdale, Roxburghshire, the valley of the Liddel, which flows 27 miles SSW, near or along the Border (q.v.) to the Esk 12 miles N. of Carlisle.

Liddon, HENRY PARRY, D.D., was born at North Stoneham, Hampshire, 20th August 1829, the son of a naval captain, and at the age of seventeen went up from King's College School, London, to Christ Church, Oxford, where in 1850 he graduated B.A. with a second-class in classics, and in 1851 obtained the coveted Johnson theological scholarship. Ordained in 1852 as senior student or fellow of Christ Church, from 1854 to 1859 he was vice-principal of Cuddesdon Theological College. He was appointed prebendary of Salisbury Cathedral in 1864, and was select preacher at Oxford in 1863-65, 1870-72, 1877-79, and 1884. Dr Liddon was a member of the Hebdomadal Council at Oxford from 1866 to 1875. In the former year he delivered his famous Bampton Lectures on the *Dignity of Our Lord* (1867; 13th ed. 1889). In 1870 Dr Liddon was created Canon Residentiary of St Paul's Cathedral, and in the same year was appointed Ireland professor of the Exegesis of the Holy Scripture in Oxford University, when he was created D.D. and honorary D.C.L. He resigned the Ireland professorship in October 1882 in consequence of ill-health, and owing to the same cause it is understood that he more than once afterwards declined a bishopric. In 1869 he republished from the *Guardian* a sketch of 'Walter Kerr Hamilton, Bishop of Salisbury.' He edited in 1874 *Bishop Andrews' Manual for the Sick*, Dr Pusey's *Prayers for a School Boy* in 1883; issued a selection of *Private Prayers* in 1884; and in conjunction with Dr William Bright wrote the *English Church Defence Tracts*. Canon Liddon's sermons have exercised a profound influence upon the thought of the

time, and many of them have been published, including those upon his friends Pusey and Bishop Wilberforce, the sermons preached before the university of Oxford, Lent lectures, and discourses on church troubles. Dr Liddon strongly opposed the Church Discipline Act of 1874, and as warmly supported (by letters in the *Times*) Mr Gladstone's crusade against the Bulgarian atrocities in 1876. He took a great interest in the Conference for the Reunion of the Churches held at Bonn in 1875, and translated Professor Rensch's account of the conference, writing also a preface for the same work. Canon Liddon was the most able and eloquent exponent of Liberal High Church principles. He had long been engaged on the *Life of Dr Pusey*, when he died suddenly at Weston-super-Mare, 9th September 1890.

Lie, JONAS, the most popular novelist of Norway, was born at Eker, near Drammen, on 6th November 1833. He studied law at Christiania, and practised as an advocate for a few years at Kongsvinger; but at length he abandoned his profession for literature. His novels give admirable realistic pictures of life in Norway, especially of the fisher-folk of the west coast. His popularity is due to the sunshine of kindness and delicate poetry that lights up his books, to the healthy tone of his writing, his fidelity to nature, and his genial humour. His best novels include *The Visionary* (1870, trans. 1894), which rapidly ran through half-a-dozen editions; *The Three-master 'Future'* (1872); *The Pilot and his Wife* (1874; Eng. trans. 1877), of which five editions were exhausted in the first year; *Go on* (1882); *A Prisoner for Life* (1883); *The Family at Gilje* (1883), his best novel; *A Whirlpool* (1884); *The Commander's Daughters* (1886); the excellent *Married Life* (1887); and *Maisa Jons* (1889), the life of a Christiania seamstress. Jonas Lie, moreover, has published two collections of *Short Stories* (3d ed. 1880, and 1885), a volume of popular *Poems* (1866), and a successful comedy, *Grabow's Cat* (1880).

Liebig, JUSTUS, FREIHERR VON, chemist, was born at Darmstadt on 12th May 1803. The bent of his mind showed itself early. He studied chemistry at Bonn and Erlangen, and in 1822 went to Paris to perfect his studies. There he was introduced by A. von Humboldt to Gay-Lussac, who took him into his private laboratory, and along with him proved that the fulminates are identical in composition with the cyanates. Humboldt two years later secured for Liebig the appointment of professor of Chemistry at the university of Giessen. This chair he exchanged in 1852 for the corresponding one at Munich. He died on 18th April 1873. In 1845 he had been created Baron (*Freiherr*). Liebig was one of the most illustrious and fruitful chemists of his age, not less renowned for his investigations and discoveries in pure chemistry than for his researches in applied chemistry, and not less honoured for the reformation he effected in chemical method than for his highly important applications of chemical knowledge to the furtherance of the arts of life. As the inventor of the extract of beef and the prepared infant food, his name is known almost everywhere throughout the civilised world. He was the founder of agricultural chemistry, and thus the greatest reformer of practical agriculture in the 19th century. Closely connected with his work in this department were his researches into the nutrition of plants. He taught that each of the non-volatile saline ingredients found in the ash is essential to the life and growth of the plant, and that the plant gets them from the soil; this in course of time exhausts the soil and makes it barren, unless the elements which go to nourish the plant be resupplied to it, whether by means of manure or through the chemical action of the

weather. Thus he directed attention to the cycle of transmutation between the mineral, the vegetable, and the animal kingdoms. In the department of animal physiology he made notable contributions to chemical science, demonstrating, amongst other things, that the heat of the animal body is wholly produced by the processes of internal combustion attendant upon the disintegration of nutritive matters; that different kinds of food serve different purposes in the body, and so admit of classification; that animal fat is produced within the animal organism from sugar and starch; and that spontaneous combustion in the human body is an impossibility. The phenomena of fermentation he explained as being purely chemical. He also investigated the constituents of the juices of flesh, and (along with Wohler, q.v.) of uric acid, with most important results. This brings us to the region of pure organic chemistry. One of the most brilliant instances of the application of the methods of organic analysis in chemistry was Liebig's and Wohler's discovery of the compound radicle benzoyl from the study of oil of bitter almonds and its derivatives. His investigations into the constituents of alcohol and its derivatives led him to oppose the existing view, that of the French chemists, Dumas and Boullay, who regarded alcohol and ether as hydrates of olefiant gas; whereas Liebig denied the existence of the olefiant gas, and believed these compounds to be derivatives of a radicle ethyl, consisting of carbon and hydrogen. In the course of this inquiry he elicited for the first time chloroform and chloral; and it was whilst investigating the conversion of alcohol into acetic acid that he discovered the compound aldehyde. Then, by the clever use of the idea of the polybasic properties of certain acids, he succeeded in determining the constitution of organic acids. Among the practical discoveries and applications of Liebig may be mentioned the invention of silver-coated mirrors, an easy method for the preparation of potassic cyanide, now so largely used in electroplating, his plan for making unfermented bread, and his methods for analysing mineral waters.

When Liebig began to teach there were no public chemical laboratories in Germany. By his initiative one was established at Giessen; and from that have grown the admirably-equipped physical laboratories of the German and other universities. Besides stimulating the study of chemistry in this way, he vastly extended the use of the method of organic analysis, and invented such useful chemical apparatus as the appliances for analysis by combustion, the tube for determining molecular weight, and Liebig's condenser. His most important treatises, all translated into English, were *Arbeitung zur Analyse organischer Körper* (1837); *Die Chemie in ihrer Anwendung auf Agricultur und Physiologie* (1840); *Die Thierchemie* (1842); *Handbuch der organischen Chemie* (1843); *Chemische Untersuchungen über das Fleisch und seine Zubereitung zum Nahrungsmittel* (1847); *Die Grundsätze der Agri-chemie* (1855); *Chemische Briefe* (1844); besides numerous papers in scientific journals (317 in the *Rep. Soc. Trans.*). See works by A. W. Hofmann (1876) and W. A. Shenstone (1895).

Liebrecht, FELIX, a learned linguist and folklorist, was born at Namslau, in Silesia, 13th March 1812; studied at Breslau, Munich, and Berlin; and became in 1849 professor of the German Language at the Athenee Royal in Liège, from which he retired in 1867. Liebrecht early made his name known by a series of admirable articles in various learned journals on the origin and diffusion of popular stories, and by translations enriched with ample annotations no less valuable than the original works themselves. Among these are *Basil's Pentameron, oder das Märchen aller*

Märchen, with a preface by Jakob Grimm (2 vols. 1846); the *Barbaram und Josephat* of Joannes Damascenus (1847); Dunlop's *Geschichte der Prosalichtungen*, with large additions (1851); and an edition of the non-historical mythological portions of Gervase of Tilbury's *Otia Imperialis* (1856). Professor Liebrecht collected his scattered papers in *Zur Volkskunde* (1879), a work which has a place on the shelves of all scientific students of comparative folklore. He died at St Hubart, in Belgium, in August 1890.

Liechtenstein, an independent principality of Europe, separated from Switzerland on the west by the Rhine; on the east it is bounded by Vorarlberg. Area, 61 sq. m.; pop. 9124. It is a mountainous district made up of the lordship of Vaduz and the township of Schellenberg. The chief town, Liechtenstein, formerly called Vaduz (pop. 1018), lies 28 miles SSW. of Bregenz on Lake Constance. The inhabitants carry on agriculture, rear cattle, and cultivate the vine. They are exempt from military duty. Liechtenstein, with several other small states, formed the fifteenth member of the German Confederation until its dissolution in 1866; but in the *Pleuum*, or full Council of the Diet, it had a separate vote. The Prince of Liechtenstein, whose family is one of the most ancient in central Europe, possesses extensive estates in Austria, Prussia, and Saxony. The little state is a constitutional sovereignty, and is ruled by the prince and a legislative assembly of fifteen members, twelve elected by the people and three by the prince. Liechtenstein belongs to the Austrian customs, postal, legal, coinage, judicial, and taxation systems. See works by Falke (3 vols. Vienna, 1868-83) and Krätzl (4th ed. Brunn, 1884).

Liège (Ger. *Lüttich*, Flemish *Luik*), a city of Belgium, occupies a picturesque site at the confluence of the Ourthe with the Meuse, by rail 62 miles S. by E. of Brussels and 47 SW. of Aix-la-Chapelle in Germany. It consists of the old town, built on the hills that overlook the Meuse on the left, the new town, down below on the right bank, and several suburbs. Notwithstanding its great manufacturing industry, it is a beautiful city, with elegant bridges, handsome squares and gardens, and fine churches and private houses. Its defences consist of a ring of modern forts and the old citadel, built in 1650, on the high ground on the left bank of the Meuse. The cathedral church was originally St Lambert's, founded in 712, destroyed by the French republicans in 1794, and wholly removed in 1802. Since that date St Paul's, founded in 968 and completed about 1528, with a good carved pulpit by Geefs, has been the church of the see. Amongst the remaining churches are two (St Denis and Holy Cross) which date from the 10th century, and three (St James', 1016-1528; St Bartholomew's, 11th and 12th centuries, with a beautiful brass font of 1112; and St Martin's, 16th century) with some architectural pretensions. The most notable amongst the secular buildings are the former bishop's palace, built in the Late Gothic style in 1508-40, and now converted into law-courts and administrative offices, and the university. This last was founded in 1817, and has about 70 teachers and 1210 students. The usual adjuncts are attached, including a museum with valuable cave remains, a library of 110,000 vols., a school of mining, and a polytechnic school. Situated in the centre of the east Belgian coal-mining district, Liège is one of the first manufacturing cities in Belgium. Its great staple is the making of firearms, of which it turns out annually (an average of nearly 900,000) more than twice the number of Birmingham and St Etienne together. But manufactories of wool, leather, and

iron-plates, together with, in a secondary degree, iron and other metal works, breweries, and distilleries, give employment to large numbers of men. The government have here a cannon-foundry and a small-arms factory. At Seraing (q.v.), 3 miles distant, are the manufacturing establishments founded by the Englishman Cockerill (q.v.). Pop. (1876) 115,851; (1891) 160,848, mostly Walloons. The Bishop of Maestricht transferred the see to Liège in 720; his successors afterwards attained to the dignity of princes of the empire and bore the title of Duke of Bouillon. The history of Liège is a long struggle between the bishop-princes and the liberty-loving burghers of the city. The latter rose in open revolt in 1407 and 1464, and on subsequent occasions; and it frequently happened that a new bishop could only gain entry into the city when he came with a foreign army at his back, as in 1648 and 1684. The city was seized by Charles the Bold of Burgundy in 1467; but he had to do his work over again, and did it with ruthless severity, in the following year. Liège was again conquered in 1691 by the French, in 1702 by Marlborough, and once more by the French in 1792. The Congress of Vienna assigned the city and the episcopal territories to the Netherlands; but in 1831 they were incorporated in the new kingdom of Belgium. See Histories by Gerlache (3d ed. 1875); Henaux (3d ed. 1876); and Hoek (1885); and compare Scott's *Quentin Durward*.

The *province* of Liège, with an area of 1117 sq. m. and a pop. (1888) of 738,694, lies between the Belgian provinces of Limburg on the north and Luxemburg on the south. In industry it ranks second among the provinces of Belgium, with one-fifth of the total output of the kingdom. Amongst the industries must be mentioned the woollen, iron, coal, steel, zinc, lead, silver, cotton, cloth, machinery, firearms, straw-hats, &c. Cheese (Limburg) and butter are the most valuable of the agricultural products. Very large numbers of pigeons are reared every year as messenger birds—in 1886 nearly a million.

Liegnitz, a town of Prussian Silesia, on the Katzbach, 38 miles W. by N. of Breslau. The town dates from the end of the 10th century. In 1163 it was chosen by the Dukes of Lower Silesia as their place of residence, and from 1241 to 1675 it was the capital of the principality of Liegnitz. In the neighbourhood (Wahlstadt) the Mongols in 1241 defeated the Poles, and filled nine sacks with the ears of their slaughtered foes. Liegnitz came into the hands of Prussia in 1742. Here in 1760 Frederick the Great routed the Austrians under London, and in 1813 Blücher defeated the French (Katzbach). It is now a place of great and varied industrial activity: iron-foundries, machine-shops, pianoforte-factories, and manufactures of woollens, cloth, hats, and gloves, with turnery, brick-making, and pottery, indicate the chief branches. Pop. (1875) 31,442; (1890) 46,874.

Lien (the *tacita hypotheca* of the civil law), in English, Irish, and American law, means the security or hold over goods or land for a debt which is due from the owner of the goods, &c. to the person in whose possession they are for the time. Possession is in general essential to constitute a lien, for the moment the goods are voluntarily parted with the lien is gone. There is an exception, however, in the case of traders like factors, and a lien, though lost, may revive if the property comes again into the possession of the creditor. Liens are general or particular. Thus, a solicitor has a general lien over his client's money, papers, and title deeds till the amount of his bill of costs is paid. So have bankers, dyers, calico-printers, factors. A particular

lien is a lien over goods, for a debt contracted in respect of such goods, as for the price of them, or some labour expended on them. Thus, a miller has a lien on the flour he has ground, a trainer on the horse he has trained, &c. A general lien is favoured by law; a particular lien is construed strictly, for it acts in favour of one creditor as against the others. There are also maritime liens and equitable liens, which do not require possession to constitute the right. The Statute of Limitations does not affect a lien, since it does not take away the right, but only bars its ordinary enforcement by action. In Scotland lien is generally called either Retention or Hypothec (see HYPOTHEC). See works by D. Y. Overton (New York, 1883) and L. A. Jones (2 vols. Boston, 1888).

Lierre, a town of Belgium, 11 miles by rail S.E. of Antwerp, has manufactures of silk, lace, shoes, beet-root sugar, with salt-works and breweries. The Gothic church of St Gummarr (1425-1557) has a fine roof-loft and a picture by Memling. Pop. (1896) 19,300.

Lieutenant (Fr., from Lat. *locum-tenens*, 'holding the place of another'), a term applied to a variety of offices of a representative kind. Thus, in military matters, a *lieutenant-general* is next in rank to a general, a *lieutenant-colonel* next to a colonel. But the title lieutenant, without qualification, denotes the second officer and deputy, or *locum-tenens*, of the troop, battery, or company commander. In the horse and field artillery he has a distinct command—viz. one section of the battery, consisting of two guns with the men, horses, and wagons belonging to them.—*Captain-lieutenant*, an obsolete rank, was the subaltern who commanded the 'colonel's company' in each regiment. The pay of a lieutenant varies from 6s. 6d. a day in the line to 10s. 4d. in the Life Guards. *Second-lieutenant* is the rank given to officers on first joining, corresponding to that of *Cornet* (q.v.) and *Ensign* (q.v.) which formerly existed.

In the British navy lieutenant is a misnomer, and conveys no adequate idea of the rank of the officer bearing that title. His functions from the time of his promotion, and for some eight years afterwards, correspond generally to those of a captain in the army, with whom he ranks, and his ordinary pay is 10s. a day. On attaining, however, eight years' seniority he ranks with a major in the army, and wears an additional stripe of gold lace on his sleeve and a star on his epaulettes as the distinguishing marks of his increased rank, and he now also receives pay at the rate of 12s. a day, which is further increased to 14s. after twelve years' service. The anomaly of the title now comes in, for, although holding field officer's rank, he is still only styled lieutenant. In foreign navies the difficulty is met by there being an intermediate rank between lieutenant and commander. In the German and Austrian navies these officers are styled 'captain-lieutenant,' in the American 'lieutenant-commander,' and in the French 'lieutenant de vaisseau.' Half-pay ranges from 4s. to 8s. 6d. a day. Six years' service afloat as naval cadet and midshipman are requisite to qualify an officer for the rank of lieutenant, and the candidate for that rank has also to pass a satisfactory examination in seamanship and general professional knowledge, which in these days includes navigation and pilotage, gunnery in all its branches, including battalion and field gun drill, electricity and torpedo work, including laying down submarine mines, and also a fair general knowledge of steam. As leaders in all minor enterprises, such as boat expeditions, cutting out, &c., lieutenants in wartime carry off most of the laurels awarded to actions of singular personal daring.

Sub-lieutenant—formerly mate or passed midshipman—is the intermediate rank in the navy between midshipman and lieutenant. When a midshipman has completed the necessary sea-service, he passes his examination in seamanship for the rank of lieutenant; if successful, he becomes an acting-sub-lieutenant, and is sent home to join the Naval College at Greenwich, where he studies for nine months previous to passing his final examination in navigation, mathematics, &c.; he then has to pass through the gunnery and torpedo schools, and also an examination in pilotage. Should he succeed in obtaining a first-class in all the subjects for examination, he is promoted at once to lieutenant, otherwise he is confirmed in the rank of sub-lieutenant, and has to serve at sea in that rank until his turn for promotion comes round. Unless specially promoted, sub-lieutenants have to serve about four years before obtaining their promotion. The obtaining of a first-class in all subjects is therefore an object of considerable importance.

Lieutenant, LORD. See LORD-LIEUTENANT.

Lieutenant-colonel. In the British army, is nominally the second officer of a regiment; but virtually a lieutenant-colonel commands every battalion of infantry and regiment of cavalry, the post of colonel being merely an honourable sinecure, with usually £1000 a year attached, awarded to a general officer. The lieutenant-colonel is responsible for the discipline of his battalion, the comfort of his men, and ultimately for every detail connected with their organisation. In this he is aided by two majors, an adjutant, and a quartermaster. In the artillery and engineers, where the rank of colonel is a substantive rank, with tangible regimental duties, the functions of lieutenant-colonel are more limited, one having charge of every two or three batteries of artillery, or two companies of engineers. The pay of a lieutenant-colonel varies from 17s. per diem in the infantry of the line to £1, 9s. 2d. in the Household Cavalry.

Lieutenant-general. See GENERAL.

Lieutenant-governor. See INDIA.

Life, in Biology, is a general term for the external and internal activities of an organism in relation to its environment. These relations may be referred to the organism as a unity, or they may be expressed more fundamentally, though incompletely, in terms of the physical and chemical changes in the living matter. Between the habits of an organism and the changes in the protoplasm there are, for higher plants and animals, three intermediate grades of interpretations—in terms of the functions of organs, the properties of tissues, and the phases of cell life. But, beyond the higher and lower limits of observable organism on the one hand and of analysable protoplasmic changes on the other, the biologist can speak with no special authority, whatever his opinions may be as to the common denominator—matter and energy, or about the transcendental interpretation of an intelligent organism (see BIOLOGY, CELL, PROTOPLASM).

Characteristics of Organisms.—The boundary between living and not-living matter is much less distinct than rough inspection suggests, but it is quite possible to point out certain characteristics which distinguish living organisms from other objects of our experience which are not-living. Some of the most striking of these characteristics may be summed up in the three words—Continuity, Rhythm, and Freedom. (*a*) So far as our experience goes, all organisms originate from other organisms, and in normal conditions become themselves parents. This fact of continuity is real and literal enough to lend a certain attribute of immortality to life, as may be gathered from the articles

HEREDITY, EMBRYOLOGY, EVOLUTION. (*b*) Organisms take in matter and energy as they live and grow, while on the other hand they also expend energy and are subject to material waste; they feed and work, rest and act, grow and reproduce, in fact pass through a rhythmic cycle of changes such that waste and repair are for variable periods kept in approximate equilibrium. From what we know of the living-matter or 'physical basis of life,' it seems that two vital processes of upbuilding and down-breaking, of composition and decomposition, of synthesis and analysis, of anabolism and katabolism, sum up the changes in the protoplasm (see ANABOLISM, FUNCTION, PROTOPLASM). (*c*) As to freedom, while organisms are much more dependent upon their environment than are inorganic bodies, it is equally true that they attain more apparent freedom. The sustained equilibrium of an organism is unified and dynamical; it admits of direct action upon surroundings, of active thrust as well as more passive parry, of activity which is sometimes called 'automatic' or 'spontaneous,' because it does not occur in direct or traceable response to stimulus from without (see ENVIRONMENT).

Definitions.—Life, like other fundamental facts, eludes definition. Bichat described it as 'the sum of the functions which resist death,' a definition superficially contradictory to Claude Bernard's epigram, 'La vie, c'est la mort.' According to De Blainville, 'life is the twofold internal movement of composition and decomposition, at once general and continuous,' while Spencer's often-quoted definition describes it as 'the definite combination of heterogeneous changes, both simultaneous and successive, in correspondence with external co-existences and sequences.' Lewes defines life as 'a series of definite and successive changes, both of structure and composition, which take place within an individual without destroying its identity,' while Joseph Cook as a transcendentalist calls life 'the invisible, individual, co-ordinating cause directing the forces involved in the production and activity of any organism possessing individuality.' Finally, Latitte, as an expositor of Comte, regards life as 'a general, internal, and continuous phenomenon of composition and decomposition, occurring in a definite organism, placed in a fit medium.' For practical purposes, life is the internal and external activity of an organism in relation to its environment.

The conditions of life vary enormously, for organisms are able to adapt themselves to most diverse environment, including under that term conditions of space and pressure, moisture and oxygen, food, heat, and light, &c. The animal life of the deep-sea illustrates interesting adaptations to great though doubtless unfelt pressure, to darkness, and other peculiar conditions; the minimum life of dried-up spores, Protozoa, ova, small animals, and seeds shows the possibility of persistence for prolonged periods without water; the fauna and flora of arctic snows and seas on the one hand, and of hot springs on the other, illustrate extreme adaptations to diverse temperature conditions; and there are abundant illustrations, from fasting men upwards, of the length of time during which life may continue without food. A few facts may be cited: small nematodes will survive desiccation for fourteen years, and, though the tales of germinating mummy wheat are highly unsatisfactory, it is certain that cereal grains may germinate after ten years' desiccation, and seeds of Leguminosae after several decennia. Seeds rich in ferments and oils have much less power of surviving than those in which starch predominates. As to temperature, dry yeast will live after exposure to 70° C., and a portion survives even at 100° C.; Pasteur heated dry fungoid spores without fatal results to 120° C.,

but the same when moist were killed at the boiling-point. Some bacteria are said to resist boiling, but the reverse is usually true. Kühne killed marine *Amoeba* at 35° C., while fresh-water forms stood 10 more. Even seeds have been known to withstand 100° C., but it is familiar that a longer exposure to much lower temperature is usually fatal. Higher plants have been known to survive burial under a glacier for four years; and fishes, frogs, &c. have often revived after being frozen hard in ice. Dry yeast, according to Cagniard de la Tour (quoted by Huxley), survived - 60° C., but when moist was killed at - 5° C.; yet Cohn cooled bacteria to - 18° C. without death, and seeds have survived such an extreme as - 120° C. To illustrate the diverse sensitiveness of animals, Semper notes that a temperature about the freezing-point of fresh water kills Infusoria but not pond-snails, that the minimum of vital activity in the former was seen at 4° C., in the latter at 12° C., yet the optimum for both is the same—viz. about 25° C. No better instance of experimental work can be referred to than Dr Dallinger's researches, in which he was able slowly to educate Monads, which normally lived at a temperature of 18° C. to thrive at over 70° C. Of the internal conditions of chill-coma, and of the *vita minima* under extremes of heat, desiccation, &c., we know almost nothing.

See DESICCATION, ENVIRONMENT, HIBERNATION; also Huxley's *Anat. of Invert. Animals* (Lond. 1871), Semper's *Animal Life* (Inter. Sc. Series, Lond. 1881), and Wiener's *Biologie der Pflanzen* (Vienna, 1889).

Origin of Life.—It is not a dogma, not yet a 'law of Biogenesis,' but a fact of experience that all living organisms arise from other living organisms—*omne vivum ex vivo*. See ABIIOGENESIS, BATHYBIUS, HEREDITY, SPONTANEOUS GENERATION.

But those who advance beyond an agnostic position as to this problem, and speculate beyond the limits of our experience, give the following four answers to the question of the historical origin of living organisms: (1) Life originated under conditions beyond the sphere of scientific inquiry. Thus, Alfred Russel Wallace postulates a 'spiritual influx' at the origin of life, while theologians are usually more explicit (see CREATION). (2) Organisms or germs of organisms were brought to the earth by meteorites from elsewhere. This hypothesis, supported by Sir William Thomson, shifts the responsibility of the problem off the shoulders of our planet, and leaves the problem of origin—elsewhere. (3) 'The question as to the origin of life,' Professor W. Preyer says, 'is not less transcendental than that as to the origin of matter and energy.' In regard to the latter, it is axiomatic that they had no origin, but are eternal, otherwise matter and energy have arisen out of nothing.' So in regard to life, he argues that it had no thinkable beginning, and that it is as legitimate to suppose that the inorganic originated from organisms as to suppose the converse. In regard to this suggestion it may be noted that while it is quite true that much of the inorganic on the earth has arisen from the work and waste, remains and decomposition of organisms, the forms of life supposed to have persisted in the ancient 'tracts of fluent heat' must have been extraordinarily different from any which we now observe. (4) Living matter evolved of itself from matter which was not living, as the outcome of unexplained processes of chemical upbuilding or synthesis. Professor Ray Lankester suggests further that the first protoplasm fed upon 'the antecedent steps in its own evolution,' 'upon the albuminoids and such other compounds that had been brought into existence by those processes, which culminated in the development of the first protoplasm.' This hypothesis is most in harmony

with the general theory of evolution, of which however it forms no integral part. It has against it the constant fact of experience and result of experiment that all life springs from life, besides serious difficulties in connection with that chemical upbuilding or synthesis, which it is so easy to postulate and so difficult to understand. See also LONGEVITY, IMMORTALITY, TRANSMIGRATION, PRE-EXISTENCE; and for Life Assurance, see INSURANCE.

Lifeboat, a boat adapted to live in a stormy sea with a view to the saving of life from shipwreck. Its qualities must be buoyancy, to avoid foundering when a sea is shipped; strength, to escape destruction from the violence of waves, from a rocky beach, or from a collision with the wreck; great lateral stability, or resistance to upsetting; speed against a heavy sea; facility for launching and taking the shore; immediate self-discharge of any water breaking into her; the important advantage of self-righting if upset; and stowage room for a large number of passengers. Although Henry Greathead (1757-1816), a boat-builder at South Shields, has very generally been credited with designing and building the first lifeboat about the year 1789, yet it is certain that Lionel Lukin, a coach-builder in Long Acre, who was not a resident at a seaport but a native of an inland town, Dummow, in Essex, designed and fitted a boat which he called an 'unimmurable' boat, for saving life in cases of shipwreck, some four or five years before Greathead brought forward his plan for a lifeboat. Lukin took out a patent for his boat in November 1785, and a Bamborough coble which he fitted up was reported to have saved several lives in the course of the first year of its use. Nothing effectual, however, was done for the shipwrecked mariner until the year 1789, when a terrible wreck took place at the mouth of the Tyne, all hands being lost at a short distance from the shore, in the presence of thousands of spectators who were powerless to render any assistance. As the result of the strong feelings which this disaster aroused, a committee was formed at South Shields, and premiums offered for the best model of a lifeboat. From the plans sent in two were selected, one by William Wouldhave, a painter, and the other by Henry Greathead; the latter eventually received the premium, and Greathead, being a boat-builder, was employed to construct a boat on his own plan with some of Wouldhave's ideas introduced. This boat was 30 feet long by 10 feet wide, and rowed ten oars double-banked; it was of the form of a steamer's paddle-box boat, with stem and stern alike, and had a curved keel, which was entirely Greathead's invention. It had, however, no means of freeing itself of water or of self-righting in the event of being upset. Lifeboats on this plan were promptly placed on different parts of the coast, and were the means of saving altogether some hundreds of lives, and even now a few boats of this type are to be found on the north-east coast.

In the year 1823 Sir William Hillary published a powerful appeal to the nation on the subject of the great loss of life from shipwrecks on our coast, and in the following year he induced Thomas Wilson, M.P. for the city of London, to take steps to convene a meeting at the London Tavern, which resulted in the establishment of the Royal National Institution for the Preservation of Life from Shipwreck (now known as the Royal National Lifeboat Institution), under the patronage of George IV. and other members of the royal family, the two archbishops, the principal bishops, and many noblemen and gentlemen. For many years the society did good work on the coast in providing and maintaining lifeboats, and rewarding their crews, &c., but after a time its work

languished. In December 1849, however, another deplorable accident took place at the mouth of the Tyne, when the South Shields lifeboat, on the Greathead plan, which went out, manned by twenty-four pilots, to the assistance of a shipwrecked crew, was upset, and drifted ashore bottom up, no less than twenty of her brave crew being drowned under the boat. This lamentable disaster once again called public attention to the lifeboat work, and in 1850 Admiral the Duke of Northumberland offered the sum of a hundred guineas for the best model of a lifeboat. In response 280 models and plans were sent in, a selection of which was afterwards shown in the Great Exhibition of 1851. James Beeching of Great Yarmouth proved to be the successful candidate for the offered premium, and he constructed a twelve-oared boat on his plan; it was 36 feet long, and was the first self-righting lifeboat ever constructed. Others followed; but, this type of boat not proving altogether satisfactory, the Lifeboat Committee requested one of their number, James Peake, Assistant-master Shipwright in

keel, B, represents the ballast, composed of iron. The festooned lines are the life-lines outside the boat, for men to catch hold of when overboard.

In fig. 2 the unshaded space, A, represents the uncovered part of the deck; B, the relieving-tubes; C, the side air-cases above the deck; D, the end air-cases; E, the ventilating scuttles; F, the water-ballast tanks; G, the plugs; and H, the pumps of the ballast-tanks. Fig. 3 represents the body plan or cross-sections at various distances from stem to stern. Fig. 4 gives the midship section.

The lifeboat transporting-carriage is a very important auxiliary to the boat. Nearly every lifeboat, except a few of the larger size, is provided with a carriage, on which she is kept in the boat-house ready for immediate transportation to the most favourable position for launching to a wreck. A lifeboat is thus made available for a greater extent of coast than she otherwise would be; and even when launched from abreast of the boat-house she can generally be much quicker conveyed to the water's edge than without a carriage. In addition

to this ordinary use, a carriage is of immense service in launching a boat from a beach; indeed, to such an extent is this the case that a boat can be readily launched from a carriage in a high surf, when without one it would often be very difficult to do so. The carriage consists of a fore and main body. The latter is formed of a keelway, and of bilge-ways attached to it, and resting on the main axle, the boat's weight being entirely on the rollers of the keelway. Its leading characteristics are that while for launching it forms an inclined plane, down which the boat can be launched off the rear end with considerable impetus; it can also be used for replacing the boat, the incline plane being reversed by removing the fore-carriage. A very full equipment of stores is

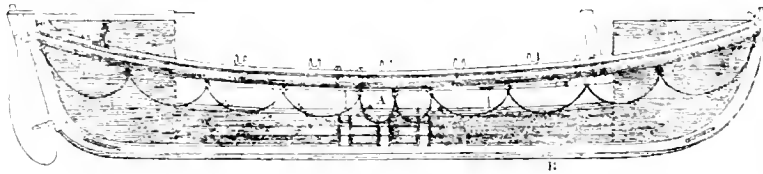

Fig. 1.—Profile.

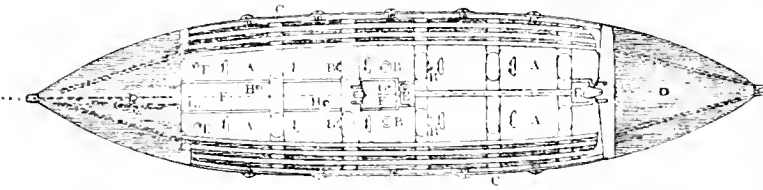

Fig 2—Deck Plan.

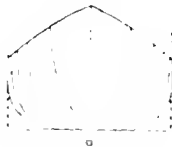

Fig. 3.—Body Plan.

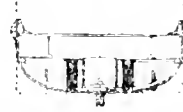

Fig 4.—Midship Section.

Woolwich Dockyard, to embody as many as possible of the good qualities of the best plans into a new design. This was accordingly done, and such a lifeboat was built in Woolwich Dockyard, at the expense of the government. Many modifications and alterations were afterwards made in the boat, and this design of lifeboat has been greatly improved of late years by the officers of the Royal National Lifeboat Institution, so that the self-righting lifeboat can truly be designated an *omnium gatherum*, and cannot be looked upon as any one man's design or invention.

The following drawings show the general outline and principal fittings of a 34 feet by 7½ feet self-righting boat. Fig. 1 gives the profile or broad-side view, the shaded part showing that devoted to the air-cases, which give extra buoyancy. The letter A shows the deck, and the unshaded parts the relieving-tubes, by which any water that breaks on board escapes. The shaded part of the

supplied to the lifeboats of the Institution, such as cork life-belts, anchors and cables, grapnels and lines, life-buoys, lanterns, rockets, and many other articles, together with portable or launching skids.

The boats of the National Lifeboat Institution, and all belonging to them, are kept in roony and substantial boat-houses, under lock and key, in charge of paid coxswains, under the general superintendence of local honorary committees of residents in the several localities. Each boat has its appointed coxswain at a salary of £8, and an assistant at £2 a year, with further allowances under special circumstances. The crew consists, in addition, of a bowman, and as many boatmen as the boat pulls oars. The members of the volunteer crews are registered, and, wherever practicable, at least double the number of men required are entered on the register. Such men are mostly resident boatmen, fishermen, or coastguardmen. On every occasion of going afloat to save life the

coxswain and each of the crew receive alike from the funds of the Institution (whether successful or not) 10s. if by day, and £1 if by night; and usually 4s. each for every time of going aloft for exercise. A reward of 7s. is given to the man who first brings intelligence of a wreck at such a distance along the coast as not to be in sight of the coast-guard station or other lookout. A flag hoisted by day, and the firing of a cannonade (or other alarm signal) by night, are the well-known signals for calling the crew together. On boarding wrecks, the preservation of life is the sole consideration. Should any goods or merchandise be brought into the lifeboat, contrary to the coxswain's remonstrance, he is authorised to throw them overboard.

The average cost of a lifeboat station is £1050, and is made up as follows: Lifeboat and her equipment, £700; boat-house, £350. The average annual expense of maintaining a lifeboat station is £70. The Royal National Lifeboat Institution in 1890 had 297 lifeboats under its management on various parts of the coasts of the United Kingdom. They were instrumental during 1889 in saving 420 lives from different wrecks, besides preserving a vast amount of property, and assisting to save or absolutely saving 17 vessels from partial or total destruction. Besides the laurels resulting in the saving of life or property, the lifeboats went out 141 times in response to signals of distress or what were supposed to be such, only to find either that the vessels were out of danger or that incorrect signals had been made. During the year the Institution also granted rewards for the saving of 207 lives by means of shore-boats, fishing-boats, or by other means, so that the committee bestowed rewards, in the year 1889, for the saving of 627 lives, making a grand total of 34,670 lives, for the saving of which the society has granted rewards since its establishment in 1824. Every effort is made by the committee to place and maintain the lifeboat service in the highest state of efficiency, but this cannot possibly be done without a very large annual outlay. In 1890 the Institution produced the latest novelty in shipbuilding in the shape of a steam lifeboat, which was named the 'Duke of Northumberland,' and stationed at Harwich for trial. The Institution had for several years been earnestly endeavouring, by the offer of gold and silver medals and in other ways, to find a means of propelling lifeboats mechanically. A steel steam lifeboat of 1890 was propelled by a turbine wheel. To the end of 1896 the total number of lives saved was 49,544; in 1896 alone, 461 lives and 29 vessels. The expenditure for the year was £75,417.

Lifeboat societies have been successfully organised on the principles of the Royal National Lifeboat Institution in France, Germany, Spain, Russia, Austria, Italy, Turkey, Holland, and Denmark. In the United States the life-saving service is a government organisation, under the Treasury Department at Washington, and extends to both the sea and lake coasts. There are three classes of stations: (1) complete life-saving stations, with resident crews; (2) lifeboat stations, with a resident keeper only and volunteer crews; and (3) provisioned houses of refuge, in charge of a keeper, for the desolate eastern coast of Florida. At many of the stations the English lifeboat is used, but its weight and draught are too great for use along the flat Atlantic sand-beaches, and there it has been superseded by the light American surf-boat of cedar, fitted with air-cases at the ends and cork fenders. The first lifeboat station was built at Cohasset, Massachusetts, in 1807; the first stations erected by the government were eight, placed on the New Jersey coast, between Sandy Hook and Little Egg Harbor, in 1848. The whole coast is now divided into 12 districts, and the splendid conception of a

girdle of stations round all the sea and lake shores promises to be fulfilled. On the Atlantic coast they are placed 5 miles apart, on an average, and a system of patrol is carefully maintained. The cost of a fully equipped station is about \$6000, and of a house of refuge about half that amount. The keepers receive \$700 a year, the crew each \$50 a month.

Life Guards. See **GUARDS.**

Liferent. in Scotch law, means a right to use a heritable estate for life, the person enjoying it being called a liferenter. For life-estate, in English law, see **ESTATE.**

Life-saving Apparatus. *Life-boats* and *life-belts* and other life-saving appliances are inventions for the preservation of life in cases of shipwreck. In the mercantile marine and passenger ships there are now life-belts for every man and to spare. Buoys are carried on the bridge and at the stern of most ships in the mercantile marine. The danger to ships' ordinary lifeboats is that, from being so long out of the water, unless attended to they get so dry that when floated they fill. Although against regulations, these boats have been known to be filled with cargo. Sometimes the handiest life-buoy is an empty water-cask, well bunged up, and with ropes around it to hold on by. There are various kinds of buoyant pillows, life-jackets of india-rubber cloth, and mattresses. The cork-mattress of Admiral Sir A. P. Ryder can float three men in an upright position.

The life-belt of the Royal National Lifeboat Institution, designed by Admiral Ward in 1854, is

made of cork covered with canvas, and is both strong and buoyant. It has four separate compartments, so that if one should be punctured and burst the belt's buoyant power is not entirely destroyed. It is represented in the fig. Each lifeboatman's life-belt must have sufficient extra buoyancy to support a man heavily clothed, with his head and shoulders above the water, and to enable him to support another person besides himself. It must be flexible in order to fit tightly into the shape of the wearer. There is a division between the upper and lower parts so that it can be securely fastened round the waist, and not impede breathing or the muscular action of the chest or arms.



Life-belt.

The Merchant Shipping Life-saving Appliances Act, 1888, stipulates that the owner and master of every British ship must see that it is provided with such boats, life jackets, and other appliances for saving life at sea as are best adapted for securing the safety of the crew and passengers. The penalty to the owner if in fault in proceeding on a voyage without the necessary life-saving appliances, or if these have been lost or destroyed, is £100; to the master £50, if in fault. The rules which came into force on 1st November 1890 were drawn up by a committee appointed by the President of the Board of Trade, and may be made, rescinded, and varied by the Board. The rules under this act give the number of boats for steamships carrying emigrants, the boats under davits being sufficient to accommodate all persons on board. If the boats under davits do not furnish sufficient accommodation, then additional wood, metal, collapsible, or other boats of approved description, or approved life-rats shall be

carried. Ships of this class must also carry not less than one approved life-buoy for every boat placed under davits, and life-belts sufficient for each person on board ship.

The same regulation as to boats and life-belts and buoys applies to sailing-ships, to steamships carrying passengers between places in the United Kingdom and ports in Europe between the Elbe and Brest, except that a deficiency of boats or life-rafts may be made up by an equivalent number of approved buoyant deck seats or deck fittings. Not fewer than six approved life-buoys must also be carried, and life-belts sufficient for every one on board. The same applies to other steamships carrying passengers within certain specified limits of the home trade; there are also rules for steamers going short excursions, and for those plying on rivers and lakes. The boats must be of lifeboat construction, with approved appliances for lowering them. A life-raft must for every person carried have 3 cubic feet of strong and serviceable enclosed air-tight compartments. Approved buoyant apparatus shall be deemed sufficient for a number of persons to be ascertained by dividing the number of pounds of iron which it is capable of supporting by thirty-two. An approved life-belt shall mean a belt which does not require to be inflated before use, and which is capable of floating in the water for twenty-four hours with 15 lb. of iron suspended from it. An approved life-buoy shall be built of solid cork, and fitted with life-lines and loops, and capable of floating in the water for at least twenty-four hours with 32 lb. of iron suspended from it. All life-belts and life-buoys must be so placed on board ship as to be readily accessible to passengers.

Mortars and Rockets.—When a lifeboat is not at hand, or a raging sea and shoal coast render its use impracticable, a distressed ship may often receive help from shore by means of the mortar or rocket-apparatus. Captain Manby in 1807 invented his *life-mortar*, to discharge a shot with curved barbs that would lay hold of the rigging or bulwarks of the ship; the rocket-apparatus is based upon this. Sergeant Bell of the Royal Artillery had previously (1791) devised a method of firing a shot and line from a distressed ship. Colonel Boxer, Trengrouse, Dennett, Carte, and others made variations and improvements in line-throwing apparatus. (The Lyle gun, the invention of Captain D. A. Lyle, United States army, weighs only 185 lb., has a much longer range than the epouvrette mortar, and combines the other advantages of great strength and simplicity, requiring only the insertion of a cartridge with a line attached to the shot.) The usual method of procedure is to fire a rocket over the wreck; by the light line attached the wrecked crew haul out the whip or double or endless line rove through a tail-block. A thicker rope is pulled over to the ship by means of the line, and a hawser by means of the rope, on which articles can be slung and drawn to and fro. The life-buoy being run out along the rope, the crew can be saved one by one; or, by the life-car, introduced in America about 1848, seven or eight can be drawn ashore at a time. The Life-rocket Department is under the Board of Trade. There were 292 rocket-stations in Great Britain in 1889, 7 chill ladder stations, and 4 heaving-line and life-buoy stations; and 226 lives were saved by means of the rocket apparatus in 1888-89. In 1881 657 lives were saved. The coasts of the United Kingdom are classified into coastguard divisions or wreck-registrars' districts, and the coastguard-inspector has control over all the rockets, mortars, buoys, belts, and lines kept at the various sea-side stations in his district. At each station is kept a cart, expressly made to contain all the requisites for

the rocket-apparatus, ready packed. The Board of Trade now gives a sum of money for every life saved, besides medals for special acts of bravery.

Liffey, a river of Ireland, winding 50 miles westward and east-north-eastward through Wicklow, Kildare, and Dublin counties, to Dublin Bay.

Lifts. Under this term are included numerous contrivances for raising weights. Such machines have various names: hoists—usually hand-worked and for lifting light goods in warehouses; elevators—chiefly used for taking passengers or their luggage, &c. to the upper floors of large hotels, business premises, &c.—and so on. There are also special Elevators (q.v.) for grain. Lifts are often on a large scale, such, for example, as occur on certain canals in place of locks at changes of level—where practically a section of the canal is alternately raised and lowered; and again on underground railways to bring passengers to the surface level (there are notable examples at the Mersey Tunnel).

Lifts consist primarily of a cage for the people or goods raised, a shaft in which this cage works, and the necessary machinery for raising or lowering the cage. There are two chief methods in use for this latter purpose; in the one the cage has attached to its top ropes or chains which are wound up on a barrel or drum; in the other the cage is lifted by hydraulic pressure applied directly, or through the intervention of chains and ropes.

The ropes in use are, for light work, hempen; for heavy work, steel-wire ropes or chains. It is usual to counterbalance the dead-weight—i.e. the weight of the cage; in this case the rope attached to the top of the cage is generally not the lifting rope. The cage-rope is simply carried up to the top of the shaft, over a pulley there, and has suspended at its other end the counterbalance; the working rope operates the shaft of this pulley, and so lifts the cage. This saves a good deal of waste work, since the load lifted each time is only the net load, passengers and goods.

Hoists all require to be provided with some automatic clutch arrangements in case the chains or ropes break, water leaks off, the rams or pistons fracture, &c., otherwise the cages would run down with destructive velocity. These clutches are usually some form of catch kept clear of the side guides in ordinary working, but set in action by compressed springs when an accident happens. They should always be regularly tested to see if they are in working order.

Ligaments are cords, bands, or membranous expansions of white fibrous tissue, which play an extremely important part in the mechanism of joints, seeing that they pass in fixed directions from one bone to another, and serve to limit some movement of a joint, while they freely allow others. Ligaments have been arranged in three classes: (1) *Funicular*, rounded cords, such as the external lateral ligament of the knee-joint, the perpendicular ligament of the ankle-joint, &c.; (2) *Fascicular*, flattened bands, more or less expanded, such as the lateral ligaments of the elbow-joint, and the great majority of ligaments in the body; (3) *Capsular*, which are barrel-shaped expansions attached by their two ends to the two bones entering into the formation of the joint, which they completely but loosely invest; they constitute one of the chief characters of the ball-and-socket joint, and occur in the shoulder and hip joints. See JOINTS.

Ligan. See FLOTSAM.

Ligature, in Surgery. See BLEEDING.

Light. The general doctrine of Light is now only a part of the general theory of Radiation,

which comprises Radiant Heat and Actinic and Electric Radiation as well as Light; but, since the battle as to the nature of radiation in general was first waged round light itself, it is convenient to consider light as representing all the forms of radiation. By elementary observation it is found that light travels (within a uniform medium) in straight lines in all directions; that it accordingly, when proceeding from a point or a very small source, covers areas which vary as the squares of the distance; that shadows obey a similar law; that it is seen some time before the corresponding sound is heard; all which points to a quick propagation of something in straight lines. What is this which is propagated—matter, motion, or condition? The simplest explanation was that luminous bodies emitted something material whose impact affected the sensitive eye; that the reflection of light at surfaces was due to elastic rebound of this quick-travelling material. These phenomena might be equally well explained by waves travelling and being reflected; but Sir Isaac Newton could not reconcile himself to the notion of waves travelling in straight lines and not spreading. This difficulty, which we now know not to be a real one, inasmuch as it is only a question of proportion between the breadth of the wave-front and the distance between successive waves whether a wave-motion shall or shall not travel in straight lines, led him to adopt and develop the corpuscular or emission theory of light. According to this all luminous bodies emit with equal velocities (a troublesome postulate, since the retarding attraction of the sun is so much greater than that of a candle-flame) a number of elastic corpuscles (whose mass must be extremely small, otherwise, with the velocity of more than 186,000 miles per second, their momentum would be destructive), which travel in straight lines, are reflected, and are refracted (provided that they travel *more* rapidly in the denser medium than in air or *in vacuo*, in a direction at right angles to the bounding surface between the rarer and the denser medium). But here begin the difficulties: refraction is always accompanied by reflection, whence some corpuscles enter the denser medium, some rebound; hence a theory of easy fits of reflection and transmission had to be developed, and this involved as its explanation a theory of vibration of a general medium some way in advance of the travelling corpuscles, so as to aid or check their entrance into the denser medium. Newton discovered that the different colours of the spectrum were unequally refracted in glass; from this he had to infer that there were as many different kinds of molecules emitted as there were colours in the spectrum. Then, again, shadows are not absolute; the shadow of a hair produced by sunlight passing through a minute pinhole in which stands a droplet of water is bright in the centre; hence explanations had to be provided to account for the bending of rays round an object; then these explanations failed to account for similar phenomena observed when light was reflected from two mirrors. The theory became loaded with a mass of hypotheses devised to explain each particular phenomenon; but the great authority of Newton maintained its vitality down to the time and person of Sir David Brewster.

The wave-theory of light was suggested by Grimaldi, Hooke, and others; was formed by Huygens (1678), who explained double refraction; lay in abeyance until Young revived it at the beginning of the 19th century; was developed by Fresnel (1815 onwards); and has now definitely displaced the emission-theory. According to it light consists of vibrations in an all-pervading elastic jelly-like ether; the vibrations are, unlike those of sound, in directions at right angles to the direc-

tions of propagation; and 'rays of light' are mere lines showing the direction of propagation of (and in isotropic media at right angles to) the corresponding portions of the wave-front. This theory involves the admission of a vibrating ether; so, indeed, did Newton's. The transmission in straight lines is easily explained; points lying to one side are not affected, because different parts of the wave-front neutralise one another's effects, if the wave-length be relatively small; even sound travelling through large apertures travels in straight lines. The wave-theory readily explains reflection; in refraction it assumes that the waves travel *less* rapidly in the denser medium (which is found to be true, and therefore disposes crucially of the emission-theory), and it explains the accompanying reflected wave; it explains double refraction, polarisation, interference, colour (different wave-lengths), diffraction, &c. Dispersion is not yet completely explained, because data are wanting, though Cauchy's ideas, as developed by Sir William Thomson, have shown that this is a phenomenon of waves of different lengths passing through finely non-homogeneous matter. The wave-theory has also proved the means of forecasting most recondite and unexpected phenomena.

But, then, what is a 'wave?' It is not necessarily a wave of motion. All the phenomena are explicable as phenomena of rhythmical disturbance of some kind, and the 'wave-theory' really goes no further than to state this. The rhythmical disturbance may be one of position (wave-motion), of stress, of electrical condition, possibly of twist in the ether. According to Clerk-Maxwell's theory every portion of the ether in the path of a beam of light is subject to rapidly-alternating stresses transverse to the ray, and is therefore in a rapidly-alternating electric and also in a rapidly-alternating magnetic condition; and the curious relations now known to exist between beams of light and the field of force of a magnet lend the greatest probability to this theory. Besides, Hertz's discoveries (see MAGNETISM) have shown that phenomena of exactly the same character as those of light, and differing only in wave-length, exist in the magnetic field while induction is going on; and all the phenomena of light, radiant heat, and actinic radiation are reduced to phenomena of electromagnetic radiation between certain limits of wave-length.

The velocity of light is found by timing the eclipses of Jupiter's satellites when they are at the greatest and the least distance from the earth, by astronomical aberration-observations, by finding (Fizeau) what speed must be given to a cog-wheel to make it rotate one tooth's-breadth while light is going to a given distant mirror and returning, by finding (Foucault) what position is ultimately assumed by a ray which travels from a source to a rotating mirror, thence to a distant mirror, and thence back to the original mirror, which by this time has been rotated somewhat. In the last method it is found that the interposition of optically denser or more refractive media *retards* the light. The mean of all observations is that light of all wave-lengths travels *in vacuo* with a velocity of 30,057,400,000 centimetres or 186,772 miles per second; in air with a velocity less than this in the ratio of 10,000 to 10,003. The length of waves can be ascertained from measurement, at a sufficient distance, of the fringes produced by interference (q.v.), or by the use of diffraction-gratings ruled with n lines to the centimetre, in which case the wave-length for any particular colour is in centimetres the n th part of the sine of the angle of deflection of that colour in the first 'diffraction-spectrum,' a result easily reached through the general theory of waves. The wave-lengths of

radiant heat, light, and actinic radiations range from $\frac{1}{250}$ cm. or $\frac{1}{10000}$ inch (the longest invisible heat-rays, Langley) to $\frac{1}{3200000}$ cm. or $\frac{1}{129870000}$ inch (invisible actinic rays); the visible limits are $\frac{1}{1000000}$ and $\frac{1}{2500000}$ cm. The frequencies or number of waves per second accordingly range from 20 millions of millions to 40,000 millions of millions per second, the extreme visible limits being 392 and 757 millions of millions per second.

See ABBERRATION, DIFFRACTION, DISPERSION, ETHER, INTERFERENCE, OPTICS, PHOTOGRAPHY, POLARISATION, RADIATION, REFLECTION, REFRACTION, SHADOWS, SPECTRUM; and Fair's *Light*, Glazebrook's *Physical Optics*, Stokes's *Burton Lectures on Light*.

Light and Air, RIGHTS TO. An owner of land has a right to the light and air which pass over it; he has also the right to obstruct the light and air by erecting walls and buildings. If my neighbour builds a house on the edge of my land, he does not thereby acquire any right against me; I may build on my land so as to darken his windows. But I may, by express or implied grant, vest in him the right which is called a Servitude or an Easement—the right to forbid the erection, on my land, of any building which obstructs his lights. Up to this point the Roman, Scotch, and English law are alike in principle. The English law (as amended by the Prescription Act of 1832) allows an easement of light to be acquired against a neighbour by twenty years' enjoyment, without any grant. In Scotland such rights are not acquired by lapse of time; unless a servitude has been created, an owner may at any time build so as to darken his neighbour's windows, provided he does not act wantonly, emulously, or so as to cause a nuisance. Rights to air generally go along with rights to light; and the right is confined to air coming through windows, &c. The English law does not recognise any general right to air, such, e.g., as the right to forbid buildings which prevent air from reaching a windmill. Roman law permitted an owner to acquire a servitude of prospect—i.e. the right to forbid buildings which shut out a fine view; but the English law regards this as a fanciful and inadmissible right. In the United States rights of view—i.e. rights to open windows and to forbid buildings which obstruct them—may be acquired by one owner against another; and in some states they may be acquired by uninterrupted enjoyment for twenty or fifteen years. See Roscoe's *Digest of the Law of Light* (Lond. 1881), and Stimson's *American Statute Law*.

Lighter. See BARGE.

Lightfoot, JOHN, one of the earlier Hebrew scholars of England, was born in 1602 at Stoke-upon-Trent, in Staffordshire, son of the vicar of Uttoxeter. He had his education at Christ's College, Cambridge, and, after taking orders, became chaplain to Sir Rowland Cotton, himself a fair Hebraist. In 1629 appeared his *Erethim, or Miscellaneous Christian and Judaical*, dedicated to Sir R. Cotton, who in 1630 presented him to the rectory of Ashley in Staffordshire, where he laboured with incessant zeal for twelve years. He next removed to London, and was chosen minister of St Bartholomew's, to the parishioners of which he dedicated his *Handful of Glanings out of the Book of Exodus* (1643). Lightfoot was one of the most influential members of the Westminster Assembly in 1643, but often stood alone, as in the Erastian controversy. In the same year he was chosen Master of Catharine Hall, Cambridge, and rector of Much Munden in Hertfordshire, and in 1655 vice-chancellor of the university. At the Restoration he complied with the terms of the Act of Uniformity. He died at Ely, December 6, 1675.

The chief works of this great Rabbinical scholar were

the unfinished *Harmony of the Four Evangelists among themselves* (1644-50); *Commentary upon the Acts of the Apostles* (1645); *The Harmony, Chronicle, and Order of the Old Testament* (1647); of the New (1655); and the *Horn Hebraica et Talmudica* (1658-74; last part posthumously), the great labour of his life. The best edition of his whole works is that edited by the Rev. J. R. Pitman, with a Life (13 vols. 1822-25).

Lightfoot. JOSEPH BARBER, D.D., Bishop of Durham, was born at Liverpool in 1828, and was educated at Trinity College, Cambridge, where he graduated B.A. in 1851 as a wrangler, senior classic, and Chancellor's medallist. He was elected a Fellow of his college in 1852, and gained the Norris University prize in 1853. Ordained in 1854, he became tutor of Trinity College in 1857, Hulsean professor of Divinity at Cambridge in 1861, canon of St Paul's Cathedral in 1871, and Lady Margaret professor of Divinity at Cambridge in 1875. He received his doctor's degree in 1864, was Whitehall preacher in 1866, was appointed examining chaplain to the Archbishop of Canterbury in 1868, honorary Fellow of Trinity College, Cambridge, in 1872, select preacher at Oxford, 1874-75, and one of the Deputy-clerks of the Closet to Her Majesty, February 1875. In 1879 Dr Lightfoot accepted with great reluctance the bishopric of Durham, in succession to Dr Baring. Although confessedly the most learned New Testament scholar in the church, his powers of administration had not been tested; but in the end his appointment was not only justified so far as the diocese of Durham was concerned, but in the wider interests of the Church of England at large. While pursuing in private his own studies, he made Bishop Auckland a centre of learning and teaching for his clergy. He likewise devoted himself with untiring energy to the practical work of his see, and speedily gained the affection and confidence of all with whom he came into contact. The work of the Church Temperance Society and the White Cross Army was specially furthered by his exertions. His munificence was unbounded, and one of his last acts was to build a church at Sunderland as a thank offering for what seemed to be his recovery from a serious illness in 1888. Dr Lightfoot's influence at Cambridge as a great Christian teacher was of incalculable importance, his high personal character as well as his learning having immense weight and influence. A supreme grammarian and painstaking textual critic, he gave the world admirable commentaries on the epistles of Paul to the *Galatians* (1865), *Philippians* (1868), *Colossians* and *Philemon* (1875), to each of which were appended interesting dissertations. Unhappily he was unable to complete the Pauline Epistles, and his exhaustive work on the Apostolic Fathers remains also a splendid fragment, embracing only the two epistles ascribed to *Clement of Rome* (1869; Appendix, 1877; new ed. 1890), and *Ignatius and Polycarp* (1885; 2d ed. 3 vols. 1889). Other works were *On a Fresh Revision of the English New Testament* (1871), an edition of Dean Mansel's treatise on *The Gnostic Heresies of the First and Second Centuries* (1875), and four volumes of sermons published posthumously in 1890. He contributed to the *Journal of Philology*, Dr Smith's *Dictionary of the Bible*, of *Christian Antiquities*, and *Christian Biography*, and published in successive numbers of the *Contemporary Review* a crushing and detailed answer to the anonymous writer of *Supernatural Religion* (collected 1889). Dr Lightfoot, who was never married, died at Bournemouth on December 21, 1889, and was buried at Durham.

Lighthouse, a building erected on some conspicuous part of the coast from which a light is shown at night to guide mariners, and which serves as a landmark by day. Aids to navigation comprise

lighthouses, lightships, beacons, buoys, fog-signals, and landmarks. Lighthouses are generally placed on salient points of the coast-line, islands, isolated or sunken rocks, low promontories, and sandbanks, each requiring structures specially designed to meet the exigencies of such varied sites. When placed on headlands or large islands lighthouses are very much alike in general features, the differences being mainly in the height of the towers, depending on the distance at which the light requires to be seen, and the lighting apparatus. Towers erected on isolated wave-swept rocks in the open sea, such as Smeaton's Eddystone (now superseded by Sir James Douglass's tower), Stevenson's Bell Rock, Walker's Bishop and Wolf Rocks, Alan Stevenson's Skerryvore, David Stevenson's North Unst, and Messrs Stevenson's Dhuheartach and Chickens Rock lighthouses, Alexander's Minot's Ledge and Spectacle Reef in America, and Brehat in France, are triumphs of engineering.

The history of lighthouse construction and illumination may be said to extend over a period of more than two thousand years; but the regularly-organised life-preserving system of modern lighthouse engineering goes back very little further than the beginning of the 19th century. None of the early lighthouse buildings now exist. The Pharos of Alexandria (331 B.C.) gave its name to its successors. The Romans built lighthouses at Ostia, Ravenna, Puteoli, and other ports. The Phœnician Pharos at Coruña was repaired during the reign of the Emperor Trajan, was re-established as a lighthouse about 1634, and in 1847 had a dioptric apparatus placed in it. On the cliff at Boulogne there are the remains of a lighthouse ascribed to Caligula (40 A.D.), and at Dover there are remains of another Roman pharos. Corhan, at the mouth of the Garonne, has seen all the improvements, from the open chautler, in which billets of wood were burned, to the dioptric light combined with a four-wick lamp. Until the end of the 18th century the lighthouses of Britain and America were few in number, and of an inferior description in the great essential of a lighthouse—viz. sending the greatest number of rays of light towards the horizon. Many of the public lights in England were private property, as was also the case with the Isle of May in Scotland, the patent for which was ratified in 1641. There were only twenty-five lighthouse stations and six floating lights in England at the beginning of the 19th century. In 1786 the Northern Lighthouse Board was constituted by act of parliament, but such was the then state of commerce that the act provided for only four lighthouses; now there are no fewer than sixty-seven lighthouses under the Board's jurisdiction. The Irish Lighthouse Board was constituted about the same period. The coast and harbour lights in Great Britain and Ireland are now upwards of 880 in number. In the United States of America the first act of congress relating to lighthouses was passed in 1789, and there are now in American waters 2375 lights and light-ships and 246 fog-signals.

The early lighthouse towers had on their summits grates or chautlers, in which billets of wood or coal were burned, but though expensive to maintain—some of them using 400 tons of coal yearly—were uncertain in their appearance, varying with the ever-changing character of the atmosphere. Such coal-lights survived in Scotland till 1816, in England till 1822, and on the Baltic till 1846. As an example of a modern lighthouse tower we may take Skerryvore, which is 139 feet in height and 42 feet in diameter at the base, containing a mass of 58,580 cubic feet of granite. The foundations of all the towers exposed to the sea are quarried out of the solid rock, and all the courses are dovetailed or joggled together into each other by various devices, and

they are made solid for about 20 or 30 feet above the foundation, where they become divided off into rooms, one above another, access to which is obtained by means of ladders. The difficulties of building are very great, as may be judged from the following facts: Winstanley's Eddystone took four seasons to erect, and was finally swept away, Rudeyard's and also Smeaton's Eddystones took each three years, the Bell Rock took four years, the Skerryvore five, and Dhuheartach three and a half, the great difficulty being to effect a landing of men and materials. At Minot's Ledge, off the Massachusetts coast, General Alexander got only 30 hours of work in the first year and 157 in the second, and the histories of the Bell Rock, Skerryvore, Dhuheartach, Chickens, Eddystone, and some others tell the same tale. The cost of lighthouses may vary much; for instance, the Bell Rock cost £61,000, Skerryvore £86,000, Spectacle Reef, on Lake Huron, £60,000, Bishop £35,000, Dhuheartach £80,000, and North Unst £32,000; and it will be easily seen that an ordinary land-station, fully equipped, will cost much less—as a matter of fact, about £5000 to £10,000. Light-vessels cost about £9000.

Oil-lamps were used in lighthouses at the end of the 16th century; but liquid fuel often gave way to candles of tallow or wax. Smeaton's famous Eddystone was lighted with twenty-four candles, five of which weighed 2 lb. The use of lamps led to reflectors. The early ones were about 18 inches in diameter, and made of small squares of mirror glass, set in plaster of Paris, the lamps having torch-like wicks, the fuel ordinary whale-oil. These lamps did not give good results, and the flat wick, though an improvement, was still unsatisfactory. It was reserved for Argand (q.v.) to devise the cylindrical wick-burner. The height of the flame in the argand lamp varied with the level of the oil in the fountain, and Carcel devised the arrangements for supplying a superabundance of oil to keep the burner cool. Argand's invention is said to have been also discovered by Fenlère, who combined his lamp with the use of reflectors.

By placing a parabolic mirror behind a flame (fig. 1) all the rays of light proceeding from the focus and falling upon its surface are reflected parallel to the axis, and emerge in a beam of light. Such reflectors are generally 21 inches in diameter for fixed and 25 inches for revolving lights, their power being equal to 350 to 450 times the unassisted flame. By arranging a number of reflectors on a frame there can be sent, all round the horizon, a number of beams of light of practically equal intensity, thus producing a *flood* light; and by assembling them on a frame having three or more faces, and making this frame revolve, a *revolving* light results, the rotation of the frame thus producing a succession of light and dark intervals. These reflectors are used in some of the most characteristic lighthouses in Britain. By arranging reflectors in a certain manner on a frame, and causing it to revolve, a group-flashing light can be produced—i.e. one giving two or three flashes in

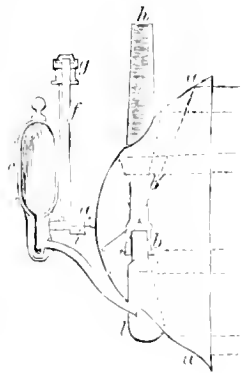

Fig. 1.

quick succession, followed by a long interval of darkness.

The ordinary parabolic reflector allows about one-third of the rays to escape past the lips by natural divergence. To prevent this waste Mr Thomas Stevenson, in 1849, devised the holophotal

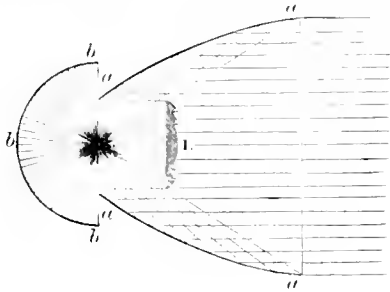

Fig. 2.

reflector (fig. 2), which consists of a lens, *L*, with a parabolic mirror, *a*, and a hemispherical mirror, *bb*, which returns all the rays falling upon it back to the flame.

To Augustin Fresnel (q.v.) belongs the honour of inventing and first employing, in 1822, the dioptric system for lighthouse purposes in combination with a central lamp having four concentric wicks. He was apparently ignorant of what had been done by Buffon and Condorcet in proposing, for burning purposes, to build up lenses in separate pieces with the view of reducing the thickness of glass and correcting to a large extent spherical aberration. So he devised the lighthouse lens, which is plano-convex, 3 feet 3 inches in height by 2 feet 6 inches in breadth, composed of a central disc, surrounded by annular rings gradually decreasing in breadth as they recede from the centre. If these lenses be assembled on a frame with eight or more sides, having a lamp in their common focus, and be made to revolve, a dioptric revolving light is produced. The lens implied a central lamp and a flame of great intensity, which

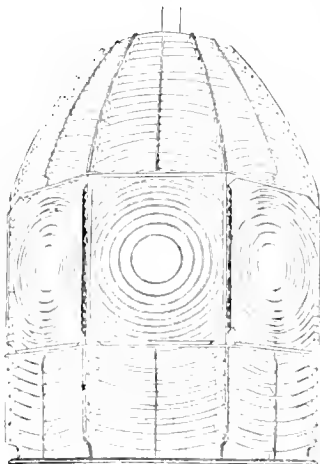

Fig. 3.—Stevenson's Holophotal Revolving Light of the first order.

this defect. When designing the revolving apparatus for Skerryvore, Mr Alan Stevenson substituted prisms for the mirrors below the lens, and also introduced totally reflecting prisms for first order lights, and, in 1849, Mr

T. Stevenson dispensed with the double agents above and below the lens, and substituted holophotal prisms which parallelise the rays in every plane (fig. 3). The holophotal apparatus is now universally adopted for revolving lights. Fresnel devised the fixed light varied by flashes by placing straight refracting prisms on a revolving frame outside a fixed apparatus. An extension of this is the condensing revolving apparatus which has been carried to such perfection in Scotland, whereby straight refracting or reflecting prisms revolve, and intercept the rays from a central fixed apparatus, so as to produce darkness over the sections they subtend, while they spread the rays which they intercept

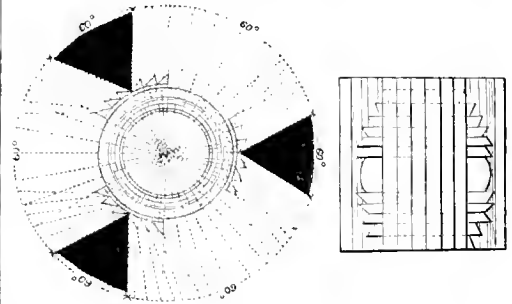

Fig. 4.

uniformly over, and thus strengthen, the intermediate sections (fig. 4). The power is increased in proportion to the duration of the intervening periods of darkness. There have been devised by Dr Hopkinson group-flashing lights by splitting up the lens into two or three portions so as to give two or more flashes (fig. 5).

The most notable improvement of recent times in revolving apparatus is what Messrs Stevenson

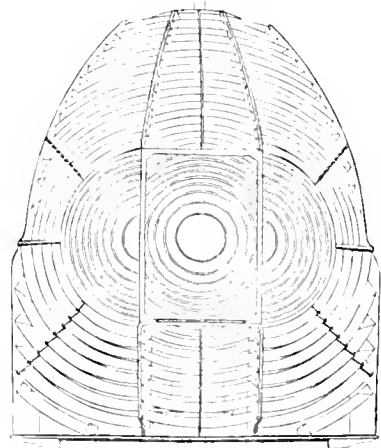

Fig. 5.—Holophotal Triple-flashing Light, first order.

suggested in 1869, and to which they have given the name *hyper-caboul*. The radius which they adopted was 1330 mm., that of Fresnel being 920 mm. The first lens of this size was made to Messrs Stevenson's design by Messrs Barbier and Fenestre, Paris. When combined with the large flames developed by the increased size of burners now used, this apparatus, when completed with the enlarged prisms above and below the lenses (fig 6), leaves

little to be desired, as all the rays of light are acted on, excessive heat is avoided, and bifurcated and trifurcated arrangements are rendered unnecessary, as one central flame is alone required. It is optically the most efficient apparatus yet made.

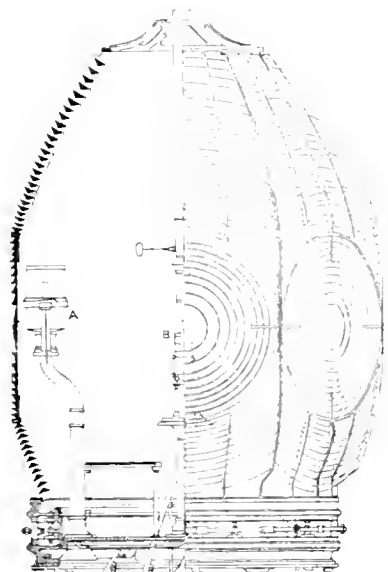

Fig. 6. Stevenson's Hyper-radiant Light.

Fresnel not only gave us the dioptric revolving light, but also the fixed dioptric apparatus, showing all round the horizon a vertical strip of light, depending on the diameter of the central flame.

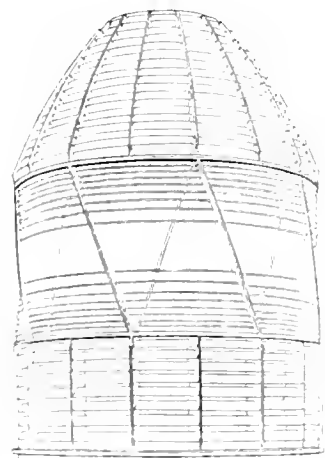

Fig. 7. Fixed Light, first order.

It is said that owing to difficulties of construction Fresnel adopted a polygonal form of thirty-two narrow lenses for the refracting hoop; but Mr Alan Stevenson, when introducing the dioptric light into Britain, designed a truly cylindrical belt, to the different sections of which he gave a rhomboidal form with oblique joints (fig. 7). He also had executed on the large scale totally reflecting prismatic rings.

Fig. 8 is a dioptric spherical mirror, which shows a dioptric holo-
photo, and fig. 9 the dioptric mirror as improved by Mr J. T. Chance, which is largely used in lighthouses, as is also the azimuthal condensing light, introduced by Messrs Stevenson in 1857, to suit the requirements of narrow sounds on the west coast of Scotland, where the light did not require to be of equal power in all directions. As shown by the chart (fig. 10), it is obvious that on the side next the shore no light is required, across the sound a noble light is all that is necessary, while up and

down the sound the sea to be illuminated is of greater or less extent, requiring corresponding intensity. Various applications of Stevenson's condensing principle are now extensively used in lighthouses. The apparent light is another of Mr T. Stevenson's devices for indicating, by means of a beam of parallel rays thrown from the shore, the position of a rock lying at some distance off. By means of apparatus placed on a beacon on the rock, the rays of light from the shore are reflected seawards so

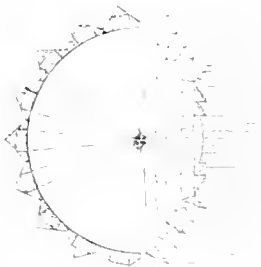

Fig. 8. Dioptric Spherical Mirror.

as to give the appearance of a light on the beacon (fig. 11). Dioptric apparatus were divided into six orders until Messrs Stevenson designed the hyper-radiant apparatus; the following table gives the internal diameter and height of the optical-glass of each:

	Internal Diameter.		Height of Glass-work.	
Hyper-radiant.	8 feet	8.72 inches	11 feet	10.28 inches.
1st Order.	6 "	0.44 "	5 "	8.7 "
2d "	4 "	7.12 "	2 "	0 "
3d "	3 "	3.37 "	5 "	1.5 "
4th "	1 "	7.68 "	2 "	8.06 "
5th "	1 "	2.77 "	1 "	10 "
6th "	0 "	11.81 "	1 "	5.5 "

Lanterns.—The lantern, or framework of glass and metal which contains the lighting apparatus, is an important part of lighthouse economy. The early lanterns had vertical and horizontal sash-bars, but in 1835 Mr Alan Stevenson, when he introduced diagonal framework for the dioptric light, extended it to the lantern.

The diagonal astragals do not intercept light in any azimuth throughout their whole height, and this trigonal arrangement secures a structure of great rigidity and strength. The astragals are of gun-metal, 1 inch section, glazed with plate-glass $\frac{1}{4}$ inch in thickness, unless in peculiarly exposed situations, where it is used $\frac{1}{2}$ inch thick. The first order lantern is 12 feet in

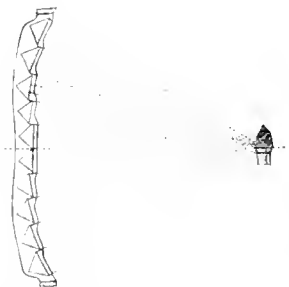

Fig. 9. Chance's Improvement on Fig. 8.



Fig. 10.

diameter, and 10 feet in height of daylight, with an outer and inner dome of copper. Mr Alan Stevenson designed a helical lantern in 1846, but it was not executed. Sir James Douglass, however, recently designed a lantern with helical astragals

14 feet in diameter, glazed with glass $\frac{1}{2}$ inch in thickness, bent to the proper curve. In the Scottish lighthouses 'storm-panes,' which are glazed copper frames, are always in readiness in case of breakage of a pane. They are fixed to the astragals by screws. There is no instance in the Northern Lighthouse service of a lantern-pane being broken by the force of the wind, but they are occasionally broken by birds or by stones being driven against them during strong gales.

Lamps.—The earliest lighthouses had lamps with two or more spouts each with a skein of cotton, until Argand and Teulere gave us the cylindrical burner, Carcel the arrangement for causing a flow of oil over the burner, Rumford the idea of concentric wicks, and Arago and Fresnel the four-wick lamp. Mr Alan Stevenson added a fifth wick, and other lighthouse engineers have

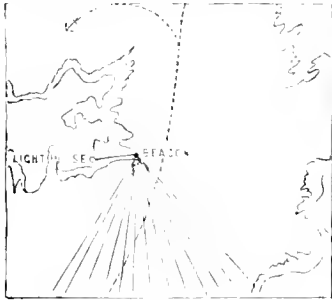

Fig. 11.

develop a flame of great purity and intensity in concentric wick lamps. Single-wick burners draw their supply by the capillary action of the wick, but with multiple-wick burners the oil is supplied by cisterns placed above the level of the burner, or from below by pumps worked by clockwork, or by pressure exerted by a weighted piston. When vegetable or animal oils are employed with multiple-wick lamps the burner requires to be kept cool and the wicks prevented from charring by causing a superabundant supply of oil—nearly three times greater than is consumed—to flow over the wicks, the overflow running back to the cistern. When paraffin is used, however, the fluid is not allowed to rise beyond a certain height in the wick-chambers, the overflow being returned by a tube to the fountain. The satisfactory results in increased photogenic power and economy arising from the use of paraffin have led to the diameters of the burners being much increased. Sir James Douglass has devised burners having seven, eight, and nine concentric wicks, which, of course, greatly increase the candle-power. Messrs Stevenson pointed out, in 1869, that much of the light from burners of greatly increased diameter, when used with revolving apparatus, was not condensed by the lenses, and not properly utilised, and that special apparatus was necessary, and hence their proposal of the hyper radiant apparatus already referred to.

Illuminants.—Almost every kind of oil, animal and vegetable, has been used in lighthouses—whale, sperm, seal, lard, olive, cocoa-nut, hempseed, colza—but these have been superseded by paraffin, not only on financial but on photogenic grounds. Sperm oil was long the illuminant used in British lights, but it gave way, in 1845, to colza at a saving of one-half the cost, while it has been succeeded by paraffin, which has raised the power of the lamps from 10 per cent. in the four-wick burner to over 100 per cent. in the one-wick lamp. Messrs Stevenson, in 1870, set at rest the comparative merits of colza and paraffin, and, when the isolated

rock station of Dhuheartach came to be lighted in 1872, they introduced paraffin as the illuminant. It may be stated that in the Scottish lighthouses alone a sum of between £4000 and £5000 is annually saved by the use of paraffin, while the power of the lights has been exalted; and most lighthouse authorities have followed their example. Paraffin can be readily obtained with a specific gravity of 0.82, and a flashing-point, close test, of 125 to 150 F., and even as high as 250 F. The following is the consumption in gallons per hour of the Doty paraffin burners: 1 wick, 0.15; 2 wicks, 0.55; 3 wicks, 1.26; 4 wicks, 2.05; 5 wicks, 3.73; 6 wicks, 4.99. The use of gas was suggested when gas-lighting was in its infancy, and the experiments did not succeed. Wherever gas can be had, and proper precautions are taken, there can be no doubt of its utility for lighthouse purposes; but when it requires to be specially made at a lighthouse station, either from coal or paraffin, it is expensive. For harbour-lights, where the supply can be readily had, it has long been used with satisfactory results. In 1827 Mr Wilson erected a very simple piece of machinery at Troon for producing an intermittent light from gas, whereby the alternations of light and darkness were got by shutting off the gas so as to extinguish the light, and again as suddenly letting on the full supply, the gas being re-ignited by a separate small burner supplied by a 'by-pass valve.' Mr T. Stevenson proposed to make intermittent gas-lights by causing the flow of gas to produce intermittent action by means of a dry meter. The meter is so made as to pass gas sufficient to keep a small jet constantly burning. The full flame of the large jet continues to burn until the action of the meter cuts off the supply, and the small jet is again kept burning alone until the full supply flows to the larger jet. Mr Wigham of Dublin has devised a system of gas-burners, having five rings of 28, 48, 68, 88, and 108 jets, the diameter of the rings varying from 4 to 11 $\frac{1}{2}$ inches, the power being 250, 680, 990, 1400, and 2300 standard candles respectively. These burners require no glass chimney, and all or any of the rings can be used to suit the state of the atmosphere. He has also strongly advocated, and has introduced at some lighthouses in Ireland, a system of superposed lenses, which have been styled biform, triform, and quadriform lights, each tier of lenses having an independent burner. Sir James Douglass has devised six and ten ring gas-burners, the gas issuing from surface holes, as in the ordinary argand, the power being 850 and 2500 candles respectively. These burners require a glass-chimney. The result of the South Foreland experiments is that, for ordinary lighthouse purposes, paraffin is the most suitable and economical illuminant, and this agrees with the conclusions arrived at by Messrs Stevenson in 1870.

Electric Light.—The electric light was first shown to the mariner in 1838 from the Foreland lighthouse, the generating machine being that of Professor Holmes; but since that date more powerful machines have been devised. The alternate current machines of Baron de Meritens have been used with good results at the Isle of May and other lighthouses. The Isle of May machines are of the L type, of the largest size hitherto constructed, and weigh about 4 $\frac{1}{2}$ tons each. The induction arrangement of each of the two machines consists of 5 sets of 12 permanent magnets, each magnet being made up of 8 plates. The armature, which makes 600 revolutions per minute, is driven by a belt from the engine—16 horse power—is two feet six inches in diameter, and is composed of 5 rings with 24 hobbins on each, arranged in groups of 4 in tension and 6 in quantity. With the circuit open each machine develops an electromotive force

of 80 volts, measured at the distributor; and with the circuit closed through an arc, 40 volts. An average current of 220 amperes is developed, thus yielding an electrical energy of 8800 watts, or 11·8 horse-power in the external circuit. The five rings are so arranged that $\frac{1}{2}$, $\frac{2}{3}$, $\frac{3}{4}$, or the whole of the current of a machine can, at pleasure, be sent to the distributor for transmission to the lantern, and the two machines can be coupled and the full current from both be employed during hazy weather. The current is conveyed to the lighthouse—a distance of 880 feet—by solid copper conductors 1 inch in diameter, with scarphed joints bolted and soldered together. The lamps are of the Serrin-Berjot type, with some modifications—notably the shunt or by-pass, whereby a large percentage of the current goes direct to the lower carbon. The carbons, which are 1·6 inch in diameter, have a core of pure graphite, and burn with great steadiness at the rate of 2 inches per hour.

The dioptric apparatus, originally used with the electric arc, was too small, and Messrs Stevenson in 1865 suggested that it should be third order, and this was generally adopted; but at the Isle of May it was made second order condensing, so as to give a group of four flashes in quick succession, with intervals of darkness of thirty seconds, the whole light being condensed into three degrees, the resulting beams being equal to three million candles with single power, and six million with double power. It is seen thirty per cent. oftener than a first-class revolving dioptric light. At Souther Point, the Forclands, Lizard, the apparatus is third order. At St Catherine's and Tino it is second order, while at Macquarie it is first order.

Characteristics.—The following are the main distinctions in use: (1) fixed lights; (2) the revolving light, which at equal periods comes into view and gradually attains its full power and then gradually disappears; (3) revolving red and white, showing alternately flashes of red and white light; (4) flashing, showing flashes at short intervals; (5) intermittent, which bursts instantaneously into full power, and, after remaining as a fixed light for a certain period, is suddenly eclipsed; and (6) group flashing, consisting of two or more flashes separated by short eclipses, the groups being separated by a longer eclipse. The use of colour is resorted to for danger arcs, or when another characteristic is not available. The two colours employed are *red* and *green*, generally produced by coloured chimneys over the lamps. Experiments made at Edinburgh show that light, in passing through red glass, should be $4\frac{1}{2}$ times stronger than for a light of the natural colour—a loss slightly redeemed in thick weather owing to the red rays not being so much absorbed.

Machines.—If the apparatus revolves, motion is generally produced by clockwork and by the fall of a weight. In the case of small apparatus, Messrs Stevenson produced motion by means of the heat from the burner causing a fan to revolve, which has since been adopted in the Trotter-Linberg system.

Distribution. The coasts of all countries have three lines of defence. There are first great sea lights which indicate important 'landfalls,' and require the most powerful apparatus; secondary lights which, though not requiring to be so powerful as those of the first order, are of great importance, as indicating turning-points in the navigation; and, lastly, harbour lights to guide ships into havens of safety. It has been laid down as an axiom by lighthouse engineers that over-sea lights of similar character should not be placed nearer each other than 100 miles, and that if possible lights near coast-lines much frequented by shipping should be designed to overlap each other.

Lightships. Light-vessels are moored in situations where it would be impossible to erect a lighthouse. They are generally wooden ships, 103 feet in length between perpendiculars, and 23½ feet beam, strongly built, copper fastened, and sheathed with muntz metal. The North Carr Light-ship, at the entrance of the Forth, is moored by a 12-inch studded chain cable and 3-ton anchor, as it is in a very exposed situation, and the engines for the fog-signal are driven by steam. The lantern is 8 feet in diameter, of steel, carried on a steel mast. The apparatus consists of eight fixed dioptric apparatus, each of 180, fitted with spherical mirrors and argand lamps. Each apparatus, with its fountain and lamp, is hung on gimbals, so balanced as to hang vertically in any position of the mast within 30 degrees of the vertical.

Early light-vessels had small lanterns suspended from the yard-arms. Mr R. Stevenson, in 1807, introduced a lantern which surrounded the mast, and all subsequent lightship lanterns have been made on his plan. All floating lights had catoptric apparatus until Messrs Stevenson, when designing the Hooghly lightships, employed dioptric apparatus. Sir James Douglass has done much to improve the lanterns of light-vessels, and introduced two-wick lamps instead of single argands.

Fog signals.—The average duration of fog on the whole coast of England is only slightly over 400 hours yearly, though in some parts it reaches 1080 hours. In Scotland the average is under 400 hours yearly, while at some parts of the coast of the United States the average is 2226 hours yearly, the highest being 2454 hours. There are few coast lighthouse stations where a phonic signal would not be a useful auxiliary, as there are times when the most powerful lights, even the electric, are obscured by dense fog, when the sailor must be guided by signals addressed to the ear. Various instruments have been used, such as bells, gongs, steam-whistles, guns, sound-rockets, tonite charges, reed trumpets, and sirens sounded by compressed air or steam. The Daboll fog-horn and siren are of American origin, the siren being the most powerful in use; but, though it has been heard at distances of upwards of 20 nautical miles, there are certain conditions of the atmosphere when its effective range is limited to 2 or 3 miles. Though bells are not effective signals, no fewer than 55 of them are used in British and 158 in American waters; and since 1811, when Stevenson introduced fog bells at the Bell Rock Tower, all subsequent rock lighthouses, owing to the want of space for other signals, have been supplied with them. Such rock tower bells vary from 3 cwt. to 2 tons. It has been found that when struck by a hammer outside, instead of by a clapper, the sound is heard at a greater distance, and when the blows are struck in rapid succession for a short time the sound is more penetrative. For the sake of distinction two bells of different tone, struck after each other, are sometimes used. Gongs, struck by hand, are still employed on board some lightships; but though the sound is distinctive it is not heard at any great distance. Steam-whistles are largely used in the United States, and guns are still employed at a few stations. Sound-rockets are charged with the ordinary composition to carry the rocket up to a height of 600 feet, when a charge of cotton powder is exploded with a report like the discharge of a piece of ordnance. The charges of cotton powder are generally 4 ounces, but 12 ounce charges are sometimes used when there is wind along with the fog. Tonite signals are used at eleven stations in Britain. The charges consist of small cylindrical discs of dry cotton powder (tonite), 4 ounces in weight, each having a hole up the centre for receiving the detonator, which is a copper tube

containing fulminate composition. The charge is fired by connecting it with an electric cable attached to a small electro-magnetic machine standing in the light-room. A light framework or jib is fixed outside the lantern, counterbalanced and raised by means of wheel-work to about 12 feet above the lantern. When the charge and detonator are attached to the ends of an electric cable, the jib is hoisted, the firing handle of the electric machine is raised and smartly pushed down, when the fuse and detonator fires the charge, which gives a loud report. An arrangement is made so that the circuit cannot be closed until the jib and charge are raised to the full height above the lantern. The Babbell horn is a metal trumpet in which a metallic reed or tongue 18 inches long, 2½ inches broad, and varying from ¼ to ½ inch in thickness at the free end, is made to vibrate by compressed air or steam being blown through it. This signal is effective, though not so powerful as that of the siren. The siren consists of a trumpet having two discs, 12-inch diameter, one of which is fixed, and one rotating with radial slits cut in them. The rotation is from 1500 to 2000 times a minute, with air at 20 lb. pressure per square inch. Holmes' siren is automatic, consisting of two cylinders having angular slots, one being fixed and the other free to rotate within the fixed cylinder; the compressed air impinging against the inclined sides of the slots causes the inner cylinder to revolve, the rapid passage of one row of slots over the other produces a series of vibrations which give the note desired, and notes of different pitch can also be produced. Sirens are used at 41 stations in British waters. At Ailsa Craig, Messrs Stevenson adopted a central station, the compressed air, at 75 lb. per square inch, being conveyed to distances of ¾ and ½ mile respectively. The south signal gives 3 blasts in quick succession every 3 minutes, the first a high note, the second a low note, the third a high note; while the north gives one blast of 5 seconds duration every 3 minutes. These signals are so arranged as to begin to sound about 1½ minute before each other, and never together. The motive power is five gas-engines, one being spare, the gas being made from the paraffin used in the lighthouse lamps. As regards the distance to which the compressed air is carried, this was a new departure in fog signalling. These signals are actuated by compressed air, the motive power being hot air, steam or gas engines, or, as at Corsewall in Scotland, by Priestman's oil-engines, with ordinary lighthouse paraffin oil as the explosive.

Administration.—British lighthouses are managed by three boards—the Trinity House for England, the Commissioners of Northern Lights for Scotland and the Isle of Man, and the Ballast Board, Dublin, for Ireland; the Board of Trade, by the Mercantile Marine Act of 1854, having control over the three boards in finance and other matters. Some colonial lights are also under the control of the Board of Trade. For the United States of America a Lighthouse Board was constituted in 1852, the Treasury defraying the cost of erecting and maintaining lighthouses and other aids to navigation. In France the lighthouse service is under the minister of Public Works and a special 'Commission des Phares.' In Sweden, Norway, Holland, Denmark, Russia, and Austria the lighthouse administration is under the Admiralty or minister of Marine. In Spain the system of administration is similar to that of France.

Lightkeepers. At lighthouse stations on shore there are two keepers, while at rock stations there are generally four, one being always on shore by rotation. Where there is a fog-signal at any station there are generally three keepers, and at electric light stations there are five, one

of them being a mechanical engineer. The crews of light-ships are eleven in number, three of the crew and the master or mate getting on shore by rotation.

See J. Smeaton, *Eddystone Lighthouse* (1791); R. Stevenson, *Bell Rock Lighthouse* (1821); Alan Stevenson, *Skerryvore Lighthouse, with Notes on Lighthouse Illumination* (1848), and *Treatise on the History, Construction, and Illumination of Lighthouses* (1850); David Stevenson, *Lighthouses* (1864); M. L. Reynaud, *Mémoire sur l'Éclairage et le Balisage des Côtes de France* (1864); L. Renard, *Les Phares* (1867); G. H. Elliott, *European Lighthouse Systems* (1875); M. E. Allard, *Mémoire sur l'Intensité et la Portée des Phares* (1876); Thomas Stevenson, *Lighthouse Construction and Illumination* (1881); M. L. Reynaud, *Phares et Balises* (1883); Sir James Douglass's Opening Address to the British Association (1886); E. P. Edwards, *Our Seamarks* (1886); P. P. Heap, *Ancient and Modern Lighthouses* (1889); and *Minutes of Proceedings of the Institution of Civil Engineers*.

Lightning (Fr. *éclair*, Ger. *Blitz*), the name given to the visible discharge of electricity between one group of clouds and another, or between the clouds and the ground. Thunder-clouds, well known by their dark and heavy look, belong usually to the cumulus type (see CLOUDS), and are found at all heights from close to or almost touching the ground up to about 6000 feet. But most of the summer thunder-clouds in Great Britain float at an altitude of from 1000 to 3000 feet. On elevated mountain-tops, 12,000 feet high or more, lightning and hail showers accompany the passage of cirrus clouds over them. Lightning occurs in three distinct forms, commonly called forked-lightning, sheet-lightning, and ball-lightning, the last class serving also as a convenient term for unexplained phenomena.

Forked-lightning appears as long flashes passing from cloud to cloud or between clouds and the ground. It gets its name from the apparently sharp bends it makes, but most photographs of lightning show it in a wavy or ribbon-like form. Occasionally it splits into several branches at one or both ends.

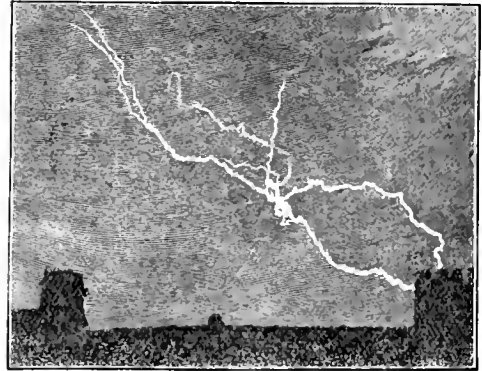

Photograph of Lightning (from *Knowledge*, June 1889).

These flashes frequently pass between clouds several miles apart, lengths of 6, 8, and even 10 miles having been observed. The thunder which accompanies this form of lightning is due to the intense and sudden heat developed in the path of the discharge expanding the air with explosive rapidity. As sound travels slowly compared with electricity and light, the noise from different parts of the flash reaches the ear in succession, and aided by echoes from the clouds, produces the prolonged rolling of the thunder-peal. The distance away of the flash can be estimated by the time between the flash and the beginning of the thunder, every 5 seconds being equivalent to 1 mile; 50 seconds or 10 miles is the

greatest observed interval at which thunder has been heard.

Sheet-lightning, sometimes called summer-lightning, is a frequent accompaniment of warm weather in temperate climates and an almost daily phenomenon in most tropical regions. It appears as a diffuse glare lighting up a whole cloud, is often of a reddish colour, and is believed to be due to discharges of feebleness than those causing forked-lightning. It may occasionally be merely the reflection on the cloud of a distant thunderstorm invisible to the spectator.

Ball-lightning is an as yet unexplained phenomenon; forked and sheet lightning are the gigantic analogues of the spark and glow from an electric machine, but nothing resembling the slow-moving, luminous globe described by those who have seen ball-lightning has ever been produced artificially. The ball has been estimated at from a few inches to over a yard in diameter; and, while not affecting anything that it does not directly touch, acts like an explosive shell on any solid body in its track, throwing down walls, making holes several feet deep in the ground, or plunging long trenches; sometimes disappearing with a loud report, at others gradually getting smaller till it vanishes. This destructive and dangerous form of lightning is happily very rare. Allied to lightning is St Elmo's Fire (q.v.). See Arthur Parnell, *The Action of Lightning* (1882).

Death by Lightning is always instantaneous, and is probably always caused by the shock to the brain and nervous system. The post-mortem appearances are extremely variable. Sometimes no marks of injury are found; but more often lacerations, bruises, burns, and occasionally even fractures of bones are present. The clothes may be burnt or torn, even when the surface of the body is not injured; metallic substances on the person may be fused, and steel magnetised. When the accident is not immediately fatal, the consequences are still more variable; insensibility, paralysis, burns, wounds, loss of hair, eruptions on the skin, hemorrhages, loss of speech or of one or more of the special senses, may all occur. The treatment must be directed to the special symptoms, which are liable to great variations. Sir B. Brodie's advice is as follows: 'Expose the body to a moderate warmth, so as to prevent the loss of animal heat, to which it is always liable when the functions of the brain are suspended or impaired, and inflate the lungs, so as to imitate natural respiration as nearly as possible.' These means should be fully tried, as respiratory action has been restored after more than an hour's suspension.

LIGHTNING-CONDUCTOR (Fr. *paratonnerre*, Ger. *Blitzableiter*). The object of a lightning-conductor is twofold: first, and most important, to drain away the electricity from passing clouds and thus prevent the occurrence of lightning in its neighbourhood; and secondly, when unable to do this, to receive and convey to earth the lightning-flash without damage to the building to which it is attached. The first object is best secured by the lightning-conductor being a sharp-pointed metallic rod standing clear above all surrounding buildings, trees, &c.; while the second necessitates its having considerable diameter to carry the short-lived but intense current produced by the flash; both require that it should be in thorough metallic connection with the earth. The action of the lightning-conductor may be illustrated by an electric machine. When the machine is in action the prime conductor, which corresponds to the thunder-cloud, discharges a rapid succession of flashes or sparks; but if a pointed metallic rod is held near it all sparking ceases, the electricity is drawn off silently as fast as it is generated by the

machine, while if a ball or blunt rod is placed near the conductor in thorough connection with the ground the sparks will pass to it as the easiest passage to earth. Good copper is almost six times better a conductor of electricity than iron, and therefore lightning-conductors are usually made of copper; but they may be equally well constructed of iron if made $2\frac{1}{2}$ times the diameter, so as to equalise their conducting power. For ordinary buildings the diameter of the rod should be at least $\frac{1}{2}$ inch for copper or $\frac{1}{4}$ inch for iron; lighthouses and similar exposed buildings are usually fitted with copper conductors $\frac{1}{2}$ inch in diameter. Instead of a solid rod, wire-rope of equivalent size is frequently used for convenience of adjustment to the buildings. The top of the conductor, always a solid rod, ends in a blunt point surrounded a few inches down by three or four sharp points projecting obliquely upwards, but not rising as high as the top; these points ought to be platinised or gilded to prevent oxidation. The rod must project higher than any other part of the building. It has been found that, roughly speaking, a lightning-conductor protects from direct flashes a conical space equal to its height with a radius at the base of double its height. Thus, a rod standing 6 feet above the gable end of an ordinary house will protect the roof ridge for 12 feet along, but if the house is more than 12 feet broad will not protect the other gable. All large masses of metal in a building, more especially the roof-gutters, should be connected with the lightning-conductor, as they may otherwise form a broken connection to earth and conduct the lightning with dangerous sparking at the breaks. Sharp bends must be avoided in the conductor, and any joints in it should be braced, or embedded in a large mass of solder, so as to avoid any risk of heating at the junction by imperfect contact. Perhaps the most important part of the lightning-conductor, and certainly the part in which it is most difficult to ensure satisfactory arrangement and workmanship, is the connection to earth. Dry earth is practically a non-conductor of electricity; damp earth is a moderately good conductor, and, being of infinite area compared with any lightning-conductor, can safely receive any discharge. The problem therefore is to make a satisfactory junction with a sufficiently large area of damp soil. This is usually done by attaching to the lower end of the lightning-conductor a brass plate about a yard square, and burying it in a damp spot surrounded by gas-coke. Sometimes the lightning-conductor is connected to an iron water or drain pipe, but not a gas-pipe, as the risk of setting fire to the gas from a spark at a break must not be incurred. A faulty earth connection makes a lightning-conductor worse than useless. Every large building requires more than one conductor, and perfect safety can only be ensured by a town or district having a sufficient number of conductors to drain passing thunder-clouds of their electricity and prevent flashes from ever occurring. The first lightning-conductor was erected by Benjamin Franklin on his own house in Philadelphia in 1752. See *Edinburgh Review* for July 1884; and O. J. Lodge, *Lightning Conductors* (1892).

LIGHTNING PRINTS are appearances, sometimes found on the skin or clothing of men or animals that either have been struck by lightning or have been in the vicinity of the stroke, and are currently believed to be pictorial representations of surrounding objects or scenery. The existence of such prints appears, from a theoretical point of view, highly improbable, as the essential conditions of forming a photographic image are wanting; still, several apparently well-authenticated instances have been recorded, one or two of which may serve to give a general idea of what are meant by lightning prints. On the 14th of November 1830

lightning struck the Chateau of Benatonière, in La Vendée; at the time a lady happened to be seated on a chair in the salon, and on the back of her dress were printed minutely the ornaments on the back of the chair. In September 1857 a peasant-girl, while herding a cow in the department of Seine-et-Marne, was overtaken by a thunderstorm. She took refuge under a tree; and the tree, the cow, and herself were struck with lightning. The cow was killed, but she recovered, and, on loosening her dress for the sake of respiring freely, she saw a picture of the cow upon her breast. These anecdotes are typical of a great mass of others. They tell of metallic objects printed on the skin, of clothes while being worn receiving impressions of neighbouring objects, or of the skin being pictured with surrounding scenery or objects during thunderstorms. One object very generally spoken of as being printed is a neighbouring tree. This may be accounted for by supposing that the lightning-discharge has taken place on the skin in the form of the electric brush (see ELECTRICITY), which has the strongest possible resemblance to a tree, and that this being imprinted on the skin by a slight charring of the tissues in its track has led observers to confound it with a neighbouring tree. Of other prints it would be difficult to give a satisfactory account, though observers have done something in imitation of them. When a coin is placed on glass and a stream of sparks poured on it from a powerful electrical machine, on the glass being breathed upon after its removal a distinct image of the coin is traced out by the dew of the breath. The parts of the glass surface in contact with the metal having received a different charge from the rest, a selective action by the glass on the dew of the breath takes place; but this is very different from the permanent image of the anecdote. With all due allowance for the possible printing-power of lightning, the accounts given of it in most cases bear the stamp of exaggeration.

Lights, USE OF, IN PUBLIC WORSHIP, a practice which prevailed in the Jewish (Exod. xxv. 31-39) and in most of the ancient religions, and which is retained both in the Roman and in the Oriental churches. The use of lights in the night-services, and in subterranean churches, such as those of the early Christians in the catacombs, is of course easily intelligible; but the practice, as bearing also a symbolical allusion to the 'Light of the World' and to the 'Light of Faith,' was not confined to occasions of necessity, but appears to have been from an early time an accompaniment of Christian worship, especially in connection with the sacraments of baptism and the eucharist. The time of the service in which lights are used has varied very much in different ages; but eventually it was extended to the entire time of the mass. In other services, also, lights have been used from an early period; e.g. lighted tapers were placed in the hand of the newly baptised, a usage still retained in the Roman Catholic Church. Two candles are *de rigueur* at mass, and four at high mass; but the most profuse use of lights is reserved for Benediction, and other services connected with the Exposition of the Host. The usage of blessing the Paschal Light is described at HOLY WEEK. The material used for lights in churches is either oil or wax; the latter in penitential seasons, and in services for the dead, being of a yellow colour. An oil lamp always burns in a Roman Catholic church to indicate the presence of the Host in the tabernacle on the altar. In the Anglican Church candle-sticks, and in some instances candles themselves, are retained in many churches, on the communion table, but in the majority of instances they are not lighted. The use of lights, except where required for giving light, has been declared illegal more than once since 1855. In the Presbyterian

and Independent churches the symbolical use of lights is rejected as superstitious.

Ligne, CHARLES JOSEPH, PRINCE DE, son of an imperial field-marshal whose seat was at Ligne, near Tournai, was born at Brussels, 23d May 1735, and as an Austrian soldier served at Kolin, Leuthen, Hochkirch, &c., in the war of the Bavarian succession, and under London at the siege of Belgrade (1789). Meanwhile he had undertaken various diplomatic missions and received numerous distinctions. A Belgian by birth, an Austrian subject, the favourite of Maria Theresa and Catharine of Russia, the friend of Frederick the Great, Voltaire, Rousseau, he was always a most welcome guest at the court of Versailles and in the Paris salons. He died 13th December 1814. Of his literary remains there were published *Mélanges* (34 vols. 1795-1811), *Œuvres Posthumes* (6 vols. 1817), a life of Prince Eugene (1809), and a collection by Madame de Staël of his *Lettres et Pensées* (1809). A new edition of his works in 4 vols. was published at Brussels in 1860. See a monograph by Thürheim (Vienna, 1876), and the *Edinburgh Review* for July 1890.

Lignin. See CELLULOSE.

Lignite, or BROWN COAL, a mineral substance of vegetable origin, like common coal, but differing from it in its more distinctly fibrous or woody formation, which is sometimes so perfect that the original structure of the wood can be discerned with the microscope, whilst its external form is also not infrequently preserved. In this state it is often called *Wood Coal*; and it sometimes occurs so little mineralised that it may be used for the purposes of wood, as at Vitry on the banks of the Seine, where the woodwork of a house has been made of it. From this to the most perfectly mineralised state it occurs in all different stages. It is often brown or brownish black, more rarely gray. It burns without swelling or running, with a weaker flame than coal; emits in burning a smell like that of peat, and leaves an ash more resembling that of wood than of coal. Wherever it occurs in sufficient abundance it is used for fuel, although as a rule very inferior to common coal. Lignite occurs sparingly in Britain—the chief locality being Govey Tracey in Devonshire, where it has long been worked. The principal repository of lignite in Europe is the Oligocene System (q.v.) of Germany, in which some of the beds attain a great thickness. Over the eastern slopes of the Rocky Mountains lignite is widely distributed, but the beds are rarely thick enough to be of economic importance. Thin beds of lignite are associated with the oligocene basalt rocks of Iceland (where it is known as 'Surtur-brand') and the Faroë Islands, just as is the case with the similar formations in Antrim and Mull.

Unlike wood, it is soluble in nitric acid and in alkaline hypochlorites, and refractory to caustic potash solution; in the latter respect it resembles coal, which is, however, not soluble in hypochlorites.

Lignum Rhodii. See CONVULVULUS.

Lignum Vitæ. See GUAIACUM.

Ligny, a Belgian village, 13 miles by rail N.E. of Charleroi, famous for the defeat of the Prussians under Blucher by the French under Napoleon, 16th June 1815, the same day on which Ney's command was engaged with the British under Wellington at Quatre-Bras. The Prussians lost 12,000 men and 21 cannon; the French, 7,000 men. See Gardner's *Quatre Bras, Ligny, and Waterloo* (1882).

Ligonyi, or ELGON, a mountain, 14,000 feet high, situated to the west of Lake Baringo in East

Equatorial Africa, with extensive artificial caves, some inhabited.

Ligulate, in Botany. See COMPOSITE.

Liguori, St ALFONSO MARIA DE, founder of the order of Liguorians or Redemptorists, was born of a noble family at Naples, 27th September 1696, and embraced the profession of the law, which, however, he suddenly relinquished to devote himself entirely to a religious life. He received priest's orders in 1725, and in 1732, with twelve companions, founded the association now called by his name. In 1762 he was appointed Bishop of Sant' Agata dei Goti, in the kingdom of Naples, and his life as a bishop was a model of the pastoral character; but shrinking from the responsibilities of such an office he resigned his see in 1775, after which date he returned to his order and continued to live in the same simple austerity as had characterised his early life. He died at Nocera dei Pagani, August 1, 1787, and was canonised in 1839. Liguori is one of the most voluminous and most popular of Catholic theological writers. His works embrace almost every department of theological learning—divinity, casuistry, exegesis, history, canon law, hagiography, asceticism, and even poetry. His correspondence also is voluminous, but is almost entirely on spiritual subjects. The principles of casuistry explained by Liguori have been received with much favour in the modern Roman schools; and in that church his moral theology, which is a modification of the so-called 'probabilistic system' of the age immediately before his own, is largely used in the direction of consciences (see CASUISTRY). Liguori's *Theologia Moralis* (8 vols.) has been reprinted numberless times, as also most of his ascetic works. The most complete edition of his works (in Italian and Latin) is that of Monza (70 vols.). They have been translated entire into French and German, and in great part into English, Spanish, Polish, &c.

The LIGURIANS, called also REDEMPTORISTS, are a congregation of missionary priests founded by Liguori in 1732, and approved by Pope Benedict XIV. in 1759. Their object is the religious instruction of the people and the reform of public morality by periodically visiting, preaching, and hearing confessions, with the consent and under the direction of the parish clergy. Their instructions are ordered to be of the plainest and most simple character, and their ministrations are entirely without pomp or ceremonial. The congregation was founded originally in Naples, but it afterwards extended to Germany, Switzerland, and Austria. In France, England, Ireland, and America, though houses of the congregation have been founded, their place is in great measure occupied by the more active congregation of the Lazarist or Vincentian Fathers (see VINCENT DE PAUL).

See Faber, *Life of St. Alphonso de Liguori* (4 vols. 1819); Meyrick, *Moral and Devotional Theology* (1857); and a short Life published by Sampkin in 1880.

Liguria. See GENOA, ROME.

Li Hung Chang, Chinese statesman, was born 26th January 1823, rose to be governor of Kiangsu (1861), and with 'Chinese' Gordon (q.v.) drove out the Taipings. He founded the Chinese navy, promoted the mercantile marine, and at the disastrous war with Japan (1894) was chief minister. He was dismissed and restored, negotiated peace, and visited Europe in 1896. He intimated with Russia, and in 1900 left his post at Canton to take a conspicuous (but suspected) part in the negotiations after the relief of the Legations. See Life by R. K. Douglas (1895).

Lilac (*Syringa*), a genus of Oleaceæ (q.v.). Busbeck (q.v.) it was who introduced the Common Lilac (*S. vulgaris*) from Persia as well as

the tulip into European gardens. From Vienna it soon spread, so that it is now to be found half wild in the hedges of some parts of Europe. There are many varieties. The flowers grow in large conical panicles; are of a bluish 'lilac' colour, purple or white, and have a very delicious odour. The leaves are a favourite food of cantharides. The bitter extract of the unripe capsules has very marked tonic and febrifugal properties. The wood is fine-grained and is used for inlaying, turning, and the making of small articles. A fragrant oil can be obtained from it by distillation. The Chinese Lilac (*S. chinensis*) has larger flowers, but with less powerful odour, and the Persian Lilac (*S. persica*) has narrower leaves. Both are often planted in gardens and pleasure-grounds. There are several other species.

Lilburne, John. See LEVELLETS.

Liliaceæ, a natural order of endogenous plants, containing about 1200 known species. They are most numerous in the warmer parts of the temperate zones. They are mostly herbaceous plants, with bulbous or tuberous, sometimes fibrous roots; rarely shrubs or trees. The shrubby and arborescent species are mostly tropical. The stem is simple, or branching towards the top, leafless or leafy. The leaves are simple, generally narrow, sometimes cylindrical, sometimes fistular. The flowers are generally large, with six-cleft or six-toothed perianth, and grow singly or in spikes, racemes, umbels, heads, or panicles. The stamens are six, opposite to the segments of the perianth; the pistil has a superior three-celled, many-seeded ovary, and a single style. The fruit is succulent or capsular; the seeds packed one upon another in two rows. This order contains many of our finest garden, greenhouse, and hothouse flowers, as lilies, tulips, dog's-tooth violet, Lily of the valley, tuberose, crown imperial and other fritillaries, hyacinths, *Gloriosa superba*; many species useful for food, as garlic, onion, leek, and other species of *Allium*, asparagus, the Quamash or Biscuit Root (*Camassia esculenta*) of North America, the Ti (*Draecena terminalis* or *Cordylone Ti*) of the South Seas, &c.; many species valuable in medicine, as squill, aloes, &c.; and some valuable for the fibre which their leaves yield, as New Zealand Flax, and the species of Bow-string Hemp, or *Sauvicularia*.—This natural order has been the subject of a number of splendid works, such as Redouté's *Les Liliacées* (8 vols. Paris, 1802–16).

Lilith. See ADAM.

Lille (Flemish *Rijssele*), a manufacturing town and first-class fortress of France, chief town of the department of Nord, is situated on a sub-tributary of the Scheldt, in a fertile district, 66 miles by rail SE. of Calais. Lille derives its name from the castle around which it originally arose, and which from its position in the midst of marshes was called L'Isle. It was founded early in the 11th century by the counts of Flanders. From 1305 it was mortgaged to France, but passed to Burgundy in 1365. Louis XIV. conquered the town in 1667, and, though it was recaptured by Marlborough and Prince Eugene in 1708, the Austrians restored it in 1713. In 1792 it successfully resisted the determined attacks of the Austrians. Its present defences consist of a pentagonal citadel, the work of Vauban, and a series of seven forts encircling the town. The old fortifications were for the most part levelled from 1858 onwards. The town is modern built and possesses few notable buildings except the church of Notre Dame (1855), and the town-hall with the museum, the famous Weier collection of drawings by the Old Masters, and a library of 41,000 volumes. The principal institutions are a Catholic free university, independent faculties of medicine and science, technical schools, a music

school, and an academy of art. Lille is a great centre of textile industries: the spinning of linen and cotton, the manufacture of thread, damask, cloth, tulle, tickings, &c.—these textile industries give employment to nearly 20,000 workpeople of tobacco, beer, paper, and sugar, dye-works, bleach ing fields, the fabrication of machinery, and oil-works indicate the chief industries. Pop. (1872) 152,775; (1886) 151,397; (1891) 160,966. See Van Hende, *Histoire de Lille* (2d ed. 1875).

Lillebonne, a town of Normandy, on the Bolbec, 28 miles WNW. of Rouen by rail. The *Julia Bana* of the Romans, it has very interesting remains of a Roman theatre, laid open in 1812; a 15th-century church; and a ruined castle of William the Conqueror. Pop. 5852.

Lillibullero, the famous political ballad that 'sung James H. out of three kingdoms.' A scurrilous attack on the Irish recruits, it is said to have been written by Lord Wharton in 1686, and the setting is ascribed to Henry Purcell.

Lilliput, the name of a fabulous kingdom described by Swift in *Gulliver's Travels*, of which the inhabitants are not greater in size than an ordinary man's finger.

Lillo, GEORGE, English dramatist, was born in London on 4th February 1693, and died on 3d September 1739. Whilst carrying on the business of a jeweller in London he wrote seven plays, two of which are frequently printed in collections of acting-plays. These are *Fatal Curiosity* (1736) and *George Barnwell* (1732), both admirably constructed and with truly tragic conclusions, though the language is inflated and conventional. His *Arden of Feversham* (written in 1736, not published till 1762) is a very good version of an old anonymous play bearing the same title, written in 1592 and reprinted by A. B. Bullen in 1888. Apart from the tragic quality of his plays, Lillo deserves mention as being almost the first English playwright to take his characters from middle-class life. For long it was an old custom to act *George Barnwell* in certain London theatres on the night after Christmas and on Easter Monday. See Lillo's *Dramatic Works, with Life* (2 vols. 1772).

Lilly, WILLIAM, astrologer, was born at Diseworth, Leicestershire, 1st May 1602. He was educated at Ashby-de-la-Zouche, and in 1620 found his way to London, where for seven years he served an ancient citizen, married his widow, and on her death in 1633 obtained a fortune of £1000. He now turned to astrology, soon acquiring a considerable fame and large profits as a caster of nativities and a predictor of future events. In 1634 he obtained permission from the Dean of Westminster to search for hidden treasure in the cloister of Westminster Abbey, but was driven from his midnight work by a storm, which he ascribes to demons. From 1644 till his death he annually issued his *Martianus Anglicus, Junior*, containing vaticinations, to which no small importance was attached by many. In the Civil War he attached himself to the parliamentary party as soon as it promised to be successful, and was rewarded with a pension, but it is highly unlikely that his own accounts of his intimacy with Lenthall, Whitelocke, Ashmole, and others are true. After the Restoration he was for some time imprisoned, on the supposition that he was acquainted with the secrets of the Republicans; but being set free, he retired to the country. He was again apprehended on suspicion of knowing something of the causes of the great fire of London in 1666. He died, 9th June 1681, at his estate at Hersham in Surrey. Lilly wrote nearly a score of works on his favourite subject, which are of no value whatever, except to illustrate the knavery

of their author and the credulity of his countrymen. Dr Nash's judgment of him as 'a time-serving rascal' may be allowed to stand—he was gibbeted by Butler under the name of Sidrophel. See his *History of his Life and Times* (1715).

Lily (*Lilium*), a genus of plants of the natural order Liliaceæ, containing a number of species much prized for the size and beauty of their flowers. The perianth is bell-shaped, and its segments are often bent back at the extremity. The root is a scaly bulb, the stem herbaceous and simple, often several feet high, bearing the flowers near its summit. The White Lily (*L. candidum*), a native of the Levant, has been long cultivated in gardens, and much sung by poets. It has large, pure white flowers, as much prized for their fragrance as for their beauty. The Orange Lily (*L. bulbiferum*), a native of the south of Europe, with large, erect, orange-coloured flowers, is a well-known and very showy ornament of the flower-garden. The Martagon or Turk's Cap Lily (*L. Martagon*), a

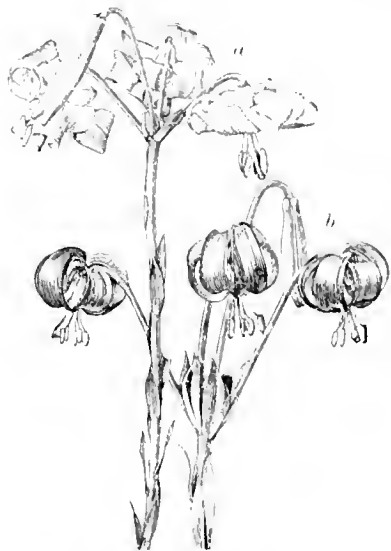

a, *Lilium testaceum*; b, *Lilium chalcedonicum*, Scarlet Turk's Cap.

native of the south of Europe, and allied species with verticillate leaves and drooping flowers, are also common in gardens. *L. chalcedonicum*, a native of the Levant, is a very brilliant species, and has been in cultivation about 300 years. The Tiger Lily (*L. tigrinum*) is a native of China, remarkable for the axillary buds on the stem; and some very fine species are natives of North America, as *L. superbum*, which grows in marshes in the United States, has a stem 6 to 8 feet high, and reflexed orange flowers, spotted with black; *L. canadense*, &c. Several very fine species have been introduced from Japan, as *L. japonicum*, *L. speciosum*, and *L. lancifolium*. The bulbs of *L. pauciflorum*, *L. Martagon*, and *L. kamschatcense* are roasted and eaten in Siberia. That of *L. candidum* loses its acridity by drying, roasting, or boiling; when cooked it is viscid, pulpy, and sugary, and is eaten in some parts of the East. Lilies are generally propagated by offset bulbs. A single scale of the bulb will, however, suffice to produce a new plant, or even part of a scale, of which skilful gardeners avail themselves.—The name lily is often popularly extended to flowers of other genera of the same order, and even of allied orders. For Lily of the Nile, see ARUM. See also FLEUR-DE-LIS.

Lily, GIGANTIC (*Dorogathes eccelsa*), of Australia, a plant of the natural order Amaryllidaceæ, with flowering stem 10 or 14, sometimes 20 feet high, bearing at top a cluster of large crimson blossoms. The stem is leafy, but the largest leaves are near the root. This plant is found on both the mountains and the sea-coast of New South Wales, and is of splendid beauty. The fibre of its leaves has been found excellent for ropes and for textile fabrics.

Lily of the Valley (*Convallaria*), a genus of plants of the natural order Liliaceæ, having terminal racemes of flowers; a white, bell-shaped, or tubular 6-cleft or 6-toothed perianth; a 3-celled germen, with two ovules in each cell, and a succulent fruit. The species commonly known as the Lily of the Valley (*C. majalis*), the *Maiden* or

Mayflower of the Germans, grows in bushy places and woods in Europe, the North of Asia, and North America, and has a leafless scape, with a raceme of small flowers turned to one side. It is a universal favourite, on account of its pleasing appearance, the fragrance of its flowers, and the early season at which



Lily of the Valley (*Convallaria majalis*).

they appear. It is therefore very often cultivated in gardens, and forced to earlier flowering in hot-houses. Varieties are in cultivation with red, variegated, and double flowers. The berries, the root, and the flowers have a nauseous, bitter, and somewhat acrid taste and purgative and diuretic effects. The smell of the flowers when in large quantity, and in a close apartment, is narcotic. Dried and powdered, they become a stimulant. The esteemed *Eau d'or* of the French is a water distilled from the flowers.—Allied to Lily of the Valley is Solomon's Seal (q.v.).

Lily, John, euphuist. See LILY.

Lilybæum. See MARSALA.

Lilye, or LILY, WILLIAM, classical grammarian, was born at Odiham, in Hampshire, about 1466, and graduated at Oxford, being elected deny of Magdalen in 1486. Having taken his B.A. degree, he travelled to the East; and at Rhodes, then the home of the Knights Hospitallers, he learned Greek from refugees from Constantinople. He afterwards spent some time studying Greek and Latin in Rome and Venice, and returned home about 1509. After teaching for a while privately in London he was appointed (1512) by Dean Colet the first head-master of the new St Paul's school; this post he held till he was carried off by the plague towards the end of 1522. Lilye, who has good claims to be considered the first who taught Greek in London, had a hand in Colet's *Bevisian Institution*, which, as corrected by Lilye's friend Erasmus, and redacted by Lilye himself, was known as the *Eton Latin Grammar*. Lilye's share embraced the lines on the genders of nouns, beginning 'Propria que maribus,' and those on the conjugation of verbs, 'As in presenti,' if no more. Besides this he wrote Latin poems, printed along with those of another great friend, Sir Thomas More, at Basel in 1518,

and a volume of Latin verse against a rival school-master, entitled *Autoboscon ad Gulielmum Horumannum* (1521).

Lima, the capital of Peru, lies in a broad valley 6 miles E. of Callao, its port, with which it is connected by two railways (9 miles). A small stream, the Rimac, flows through the city, which is laid out in regular lines, with wide, straight streets, thirty-three *plazas*, and houses mostly of one story. The seat of an archbishop, it contains not less than seventy-two sacred buildings, and the cathedral (rebuilt 1746) is, after that of Mexico, the most noteworthy in Spanish America. Among other buildings that call for mention are the Franciscan and Dominican monasteries, the latter possessing the loftiest tower in the city; and the houses of congress, formerly the headquarters of the Inquisition and of the university. The university (1551) is now housed in the old Jesuits' college; and there are also a theological seminary and several special schools, besides a botanical garden and a national library. The last institution was looted during the Chilian occupation (1881-83), and numerous statues and works of art found their way at the same time to Santiago. This disaster, added to earthquakes and revolutions, has wrought sad havoc in Lima, which remains still picturesque and beautiful, but somewhat shabby and very dirty. The trade is left almost entirely in the hands of foreigners. The manufactures are not of importance, but include the casting of iron, copper-smelting, and the preparation of furniture, silver-ware, gold-lace, and stamped leather. There is a railway to Oroya (128 miles). Lima was founded as *Ciudad de los Reyes* (the monarchs of Spain and the Three Magi), on 18th January 1535, by Pizarro, who was murdered here in 1511, and sleeps in the crypt below the cathedral. The name was afterwards changed back to that of the Indian village that had occupied the site. Earthquakes have been numerous, the most disastrous, that of 1746, destroying 5000 out of the 60,000 inhabitants. The climate of Lima is agreeable and on the whole healthy, although consumption and fevers are common. Pop. (1876) 101,488; (1895) 100,191.

Lima, capital of Allen county, Ohio, 71 miles N. of Dayton, on the Ottawa River, where several railways cross. It has steam-mills and manufactures of engines, furniture, &c. Pop. 7567.

Limasol, or LIMASSOL (Gr. *Levasson*), the chief seaport of Cyprus. It has no harbour, but the water is not so shallow as at Larnaka; and there is a large trade, chiefly with France, in wine and carobs. Limasol is the only place in Cyprus where English troops are permanently quartered—some in the town and 300 three miles inland. Pop. (1878) 6000; (1890) nearly 10,000.

Lima-wood, a name of the dye-wood also called Pernambuco-wood and Nicaragua-wood. See BRAZIL-WOOD.

Limbach, a Saxon town, 10 miles WNW. of Chemnitz, with hosiery manufactures. Pop. 10,494.

Limber is half the field equipage of a Cannon (q.v.).

Limborch, PHILIP VAN, Remonstrant theologian, was born at Amsterdam in 1633, studied there and at Utrecht, and afterwards served as a preacher at Gouda and Amsterdam, and became in 1668 professor in the Remonstrant college at Amsterdam, where he died in 1712. Of his numerous and learned works most valuable for the fullness and clearness of its exposition is his *Institutiones Theologicæ Christianæ* (1686; 5th ed. 1735). An English translation of this, by W. Jones, was

printed in 1702; and of his *History of the Inquisition*, by S. Chandler, in 1731.

Limburg, a territory on the Meuse, lying between the provinces of Liège and Brabant, was created a countship soon after its annexation by the German king (870). Shortly after 1151 it was made a duchy. The battle of Woeringen (1288) gave it to the Dukes of Brabant, after which it shared the fortunes of that state. At the peace of Münster (1648) it was divided between the United Provinces and Spain, but was again united under French rule from 1794 to 1830, and from 1830 to 1839 under the Belgian king. In 1839 it was once more divided, the lands to the west of the Meuse remaining with Belgium, whilst a long narrow strip on the east side of the river was constituted the Dutch province of Limburg. The soil of both provinces is in parts fertile, though large portions of the area are covered with moors. The marshy district of the Peel intrudes into the north of Dutch Limburg. The Belgian province has an area of 931 sq. m. and a pop. (1891) of 223,531. Capital, Hasselt. The area of the Dutch province is 930 sq. m.; pop. (1891) 259,593. Capital, Maestricht.—The well-known *Limburg cheese* is made at the little town of Limburg (pop. 4768), the former capital of the duchy, which is now in the province of Liège, 19 miles E. of the city of Liège. The old castle was destroyed by the French in 1675.—LIMBURG-AN-DER-LAHN, a town of Hesse-Nassau, 32 miles E. of Coblenz by rail, has a fine Catholic cathedral (1243). Pop. 6485.

Limbus, the name assigned by Roman Catholic theologians to that place on the fringe of hell (*Limbus patrum*) in which the just who died before Christ were detained till His resurrection, and also where infants are kept who die in original sin without baptism (*Limbus infantium*). Limbus is not a place of torture, but of a joy imperfect, and therein unlike the joy of heaven. Infants suffer only the 'pain of loss,' and in no respect the 'pain of sense,' the most aggravated of the tortures of Hell (q.v.).

Lime is the monoxide of the metal Calcium (q.v.), and is known in chemistry as one of the alkaline earths. Its symbol is CaO, its equivalent is 56, and its specific gravity is 3.08. In a state of purity it is a white caustic powder, with an alkaline reaction, and so non-fusible as to resist even the heat of the oxyhydrogen flame (see LIME-LIGHT). It is obtained by heating pure carbonate of lime (as, for instance, white Carrara marble or Iceland spar) to full redness, when the carbonic acid is expelled and lime is left. This compound, CaO, is known as *quicklime*, or, from the ordinary method of obtaining it, as *burned lime*, to distinguish it from the *hydrate of lime*, or *slaked lime*, which is represented by the formula CaO, H₂O. On pouring water on quicklime there is an augmentation of bulk, and the two enter energetically into combination; and, if the proportion of water be not too great, a light, white, dry powder is formed, and a great heat is evolved. On exposing the hydrate to a red heat the water is expelled and quicklime is left.

If quicklime, instead of being treated with water, is simply exposed to the air, it slowly attracts both aqueous vapour and carbonic acid, and becomes what is termed *air-slaked*, the resulting compound in this case being a powder which is a mixture of carbonate and hydrate of lime. Owing to this property quicklime is employed to prevent instruments and other objects from being rusted or otherwise injured by damp. A jar is partly filled with lime and placed beside the articles in a glass case or box.

Lime is about twice as soluble in cold as in boiling water, but even cold water only takes up about

$\frac{1}{35}$ of its weight of lime. This solution is known as *lime-water*, and is much employed both as a medicine and as a test for carbonic acid, which instantly renders it turbid, in consequence of the carbonate of lime that is formed being insoluble. It must, of course, be kept carefully guarded from the atmosphere, the carbonic acid of which would rapidly affect it. If in the preparation of slaked lime considerably more water is used than is necessary to form the hydrate, a white semi-fluid is produced, which is termed *milk of lime*. On allowing it to stand there is a deposition of hydrate of lime, above which is lime-water. Milk of lime is much used as a whitewash.

Lime prepared for building and other purposes by burning limestones in kilns often contains a considerable amount of impurity. But certain kinds of slightly impure are better than pure lime for making mortar. On the other hand, the lime which enters into the composition of plate and sheet glass, and which is used in some chemical industries, requires to be obtained from a nearly pure limestone. Chalk and white marble consist of almost pure carbonate of lime, but many of even the dark coloured limestones from different geological formations do not contain more than from 2 to 5 per cent. of foreign bodies, and these when burned generally yield a lime sufficiently pure for most purposes. Some limestones, again, contain from 20 to 30 per cent. of impurities, which commonly consist of silica, clay, magnesia, oxide of iron, and other bodies. These impure kinds often yield excellent hydraulic lime, which is very generally made by burning a limestone containing from 12 to 20 per cent. of silica, or of clay in which silica predominates. A less valuable hydraulic lime is prepared from a limestone containing a considerable amount of magnesia as well as clay. According to the absence or presence of foreign bodies, their nature and extent, limes are classed as (1) rich, fat, or pure lime; (2) impure or poor lime; and (3) hydraulic lime (see CEMENTS). When the percentage of magnesium carbonate in a limestone is high it is called a magnesian limestone, and this requires less fuel to burn it than a pure or nearly pure limestone. See DOLOMITE.

Besides the uses of lime noticed above, it is employed in the purification of coal-gas, in the unhairing of hides for tanning, in the preparation of stearic acid for candlemaking, for causticising alkalis, in the smelting of some metals, &c. Lime precipitates organic impurities from vegetable solutions containing sugar.

The following are the most important of the salts of lime. *Sulphate of lime* (calcium sulphate) is found native free from water, CaSO₄, as the mineral *Anhydrite* (q.v.), but more abundantly in the hydrated form, CaSO₄.2H₂O, as *Gypsum*. Sulphate of lime is a constituent of sea-water, and is also frequently present in drinking-water. For laboratory use a solution of sulphate of lime is made by shaking up the powder of burnt gypsum in water. See CALCIUM, and GYPSUM.

Carbonate of lime (calcium carbonate, CaCO₃) is abundantly present in both the inorganic and organic kingdoms. In the inorganic kingdom it occurs in a crystalline form in Iceland spar, Aragonite, and marble; while in the amorphous condition it forms the different varieties of common limestone, chalk, &c. It is always present in the ashes of plants, and it is the main constituent of the shells of crustaceans and molluscs, and occurs in considerable quantity in the bones of man and other vertebrates. See LIMESTONE; and BUILDING STONE, MARBLE.

Chloride of Calcium, CaCl₂, is a remarkably deliquescent substance and one of the most soluble

of salts on account of its great attraction for moisture. In the solid state it is much used for drying gases, and the pipes of freezing machines are filled with a solution of it to convey the low temperature produced to the cooling vessels.

There is a combination of lime with an organic acid—viz. oxalate of lime—which is of great importance in pathology as a frequent constituent of urinary calculi and sediments; for a description of it, see OXALIC ACID.

There are several compounds of phosphoric acid and lime, of which the most important is the *tribasic phosphate of lime* (tricalcium orthophosphate), sometimes termed *bone phosphate*, from its being the chief ingredient of bones. This phosphate is represented by the formula $\text{Ca}_3\text{P}_2\text{O}_8$, and occurs not only in bones, but also in the minerals apatite and phosphorite, and in the rounded nodules termed Coprolites (q.v.). It forms four-fifths of the ash of well-burned bone, the remaining fifth being chiefly carbonate of lime. This ash is known as *bone-earth*, and is employed as a manure and in the preparation of phosphorus, &c.

The soluble salts of lime give no precipitate with caustic alkalis, but yield a white precipitate with their carbonates. These reactions are also common to the salts of barium and strontium. Solution of sulphate of lime gives a white precipitate with the salts of barium and strontium. The most delicate test for lime is oxalate of ammonia, which, even in very dilute solutions, throws down a white precipitate of oxalate of lime. This precipitate is insoluble, except in mineral acids.

For the substance commonly designated as *chloride of lime*, see BLEACHING POWDER. For *lime as manure*, see MANURES.

Lime-compounds in Materia Medica.—*Quicklime*, in association with potash, either as the *Potassa cum calce*, or as *Vicenna Paste*, is occasionally used as a caustic. *Lime-water*, mixed with an equal quantity or an excess of milk, is one of our best remedies for the vomiting dependent on irritability of the stomach. From half an ounce to two or three ounces may be thus taken three or four times a day. Its use as a constituent of Carron oil in burns is noticed in the article LINIMENTS. *Chalk*, or *carbonate of lime*, when freed from the impurities with which it is often associated, is used as a dusting-powder in moist excoriations, ulcers, &c.; and, in the form of *chalk mixture* and *compound powder of chalk*, is a popular remedy in various forms of diarrhoea. A mixture of an ounce of precipitated carbonate of lime and a quarter of an ounce of finely-powdered camphor is sold as *Camphorated Crataegus Tooth-powder*.

Lime, or LINDEN (*Tilia*), a genus of trees of the natural order Tiliaceae, natives of Europe, the north of Asia, and North America. The species are very similar; graceful umbrageous trees, with deciduous, heart-shaped, serrated leaves, and cymes or panicles of rather small yellowish-green flowers; each cyme or panicle accompanied with a large, oblong, yellowish membranous bractea, with netted veins, the lower part of which adheres to the flower-stalk. The wood is light and soft, but tough, durable, and particularly suitable for carved work. It is much used by turners, and for making pill-boxes. The charcoal made of it is often used for tooth-powder. It is regarded by the makers of gunpowder as being superior to every other for their purpose; it is used also for medicinal purposes and for crayons. The use of the fibrous inner bark for making ropes, mats, and other plaited work is noticed in the article BAST. It is also used as a healing application to wounds and sores, being very mucilaginous, and abounding in a bland sap. The leaves are in some countries used as food for cattle, but cows fed on them

produce bad butter. The flowers have an agreeable odour, and abound in honey, much sought after by bees. The celebrated *Kovno Honey*, much valued for medicinal use and for making liqueurs, is the produce of great lime forests near Kovno, in Lithuania. The infusion and distilled water of the dried flowers are gently sudorific and antispasmodic. The former is in France a popular



Lime-tree (*Tilia europaea*):
a, a flower

remedy for catarrhs. The seeds abound in a fixed sweet oil. The European Lime, or Linden (*T. europaea*), often attains a large size, particularly in rich alluvial soils. Some botanists distinguish a small-leaved kind (*T. parvifolia* or *microphylla*) and a large-leaved (*T. grandifolia*) as different species; others regard them as mere varieties. The Hooded or Capuchin Lime is an interesting monstrous variety. The lime-tree is often planted for shade in towns; and the principal street of Berlin is called *Unter den Linden*, from the rows of lime-trees which line it. The lime is a very doubtful native of Britain, although indigenous on the Continent from Scandinavia to the Mediterranean. In Britain the lime-tree is generally propagated by layers. The American Lime (*T. americana*, or *T. glabra*), commonly called Basswood in America, has larger leaves than the European species. It abounds on the shores of Lakes Erie and Ontario. Other species take its place in more western and more southern regions.

Lime, the fruit of *Citrus Limetta*, similar to the Lemon (q.v.), but usually globular, with a nipple-like protuberance at the apex. It is regarded by many botanists as a hybrid between the orange and the lemon. There are many varieties, varying more or less in shape and size, and in the more essential characteristics of relative thickness, flavour, acidity, and juiciness of the rind and pulp. The tree varies as much in dimensions as the fruit, according to kind. It appears to have originated in the East, but in some of the varieties, such as the *Bergamotte lime* and *Adam's Apple*—which is often but erroneously confounded with the Shaddock (q.v.)—and others, it has been cultivated from the remotest times in Italy, the south of France, and the Mediterranean region generally. The uses of the fruit are the same practically as those of the lemon, the juice being equally efficacious as an antiscorbutic (see SCURVY).

Lime-light, light produced by a blowpipe-flame directed against a block of pure, compressed quicklime. The lime, which ought to be warmed beforehand, becomes brilliantly incandescent. The blowpipe-flame may be produced in various ways: (1) blowing oxygen through a spirit flame—light

obtained, about 150 candles; (2) oxygen under pressure, and coal-gas from the mains, brought in concentric tubes to a nozzle, where the mixture is burned in a fine jet-light, about 200 candles; (3) oxygen and coal-gas, both under pressure—light, about 400 candles; (4) the same, the coal-gas or the oxygen saturated with benzoline or ether or both benzoline and ether—light, up to 800 candles when both are employed; (5) warm oxygen, saturated with benzoline, gives light up to 1350 candles; (6) oxygen and hydrogen, up to about 800 candles. The mixed gases at the nozzle are explosive, and the greatest care must be taken to see that the flame is not allowed to run back or the mixture to take place elsewhere than at the nozzle. In the case where oxygen is saturated with combustible material the apparatus is so stuffed as not to allow an explosion to travel backwards in it. Lime-light was used on the stage as far back as 1837-38, but was improved in 1851-52. Thomas Drummond (q.v.) gave his name to an improved type.

Limerick, a county of the province of Munster, in Ireland, separated by the Shannon on the N. from Clare, and bounded E. by Tipperary, S. by Cork, and W. by Kerry. Its extreme length is 35 miles, its extreme breadth 54 miles; area, 680,842 acres, or 1063 sq. m. Pop. (1841) 330,029; (1861) 217,223; (1881) 180,632; (1891) 158,912, seven-eighths Catholics. It is an undulating plain, except on its extremities, north and south. The soil in general is fertile, especially the district called the Golden Vale, which comprises upwards of 150,000 acres, and a portion beside the Shannon below Limerick. Of the entire area 578,240 acres are in cultivation; 61 per cent. is grass-land, whilst barren soil and bogs cover only 6 per cent. Potatoes and oats are the principal crops, wheat and clover occupying the second place. Dairy-farming flourishes; woollens, flour, and paper are manufactured. The county returns two members to the House of Commons. Limerick is the only town of any size. The county formed part of the territory of Thomond, the principality of the O'Briens. After the English invasion it fell, after many vicissitudes, in great part to the Desmond Fitzgeralds—the confiscated estates of the last earl (1586) in Limerick containing 96,465 acres. Limerick is more than usually rich in antiquities, both ecclesiastical and civil, of the Celtic as well as the Anglo-Norman period. There are a great number of monastic ruins at Adare, Askeaton, &c. See the county history by Fitzgerald and McGregor (2 vols. Dublin, 1826-27).

Limerick, capital of Limerick county, Ireland, stands at the head of the estuary of the Shannon, 120 miles by rail WSW. of Dublin. It constitutes both a county of a city and a parliamentary borough, returning one member to parliament; previous to 1885 it returned two. The town consists of English Town, the original English settlement made in the reign of King John, on King's Island; Irish Town, which lies immediately to the south, on the left bank of the river; and Newtown-Pery, to the south of Irish Town, the newest and handsomest part of the city, dating from 1769. There are few objects of interest except the Protestant cathedral of St Mary, founded in 1180, and rebuilt in 1490; the Roman Catholic cathedral, a Gothic structure erected in 1860; and the fine bridges across the Shannon. Limerick manufactures a little lace, grinds flour, and cures bacon. Fourth among Irish seaports, it has a graving and a floating dock, and extensive quays; imports grain, petroleum, wine and spirits, and timber to the annual value of £683,000; the exports thence amount from £18,000 to *nil*. Pop. (1851) 53,448; (1881) 38,555; (1891) 37,155.

In the 9th century Limerick was an important Danish settlement, and remained so for two centuries longer; but the Danes were then expelled by the Irish. In 1174 the town fell into English hands. Breton made himself master of it in 1651. At the Revolution Limerick was the last stronghold of James II. in Ireland. William III. himself unsuccessfully assaulted it in 1690; but in the following year his general Ginkel had better fortune; the place was compelled to capitulate on 3d October. By the terms of the treaty of Limerick the bulk of the Irish army was permitted to enter the military service of France, and the Roman Catholics were guaranteed full religious and political liberty. The violation of the civil part of this treaty by the dominant Protestant party during the reigns of William III. and Anne, down to the 19th century, has given to Limerick the title of the 'City of the Violated Treaty.' See IRELAND, p. 205; and Linnæus's history of the town (1866).

Limestone, the popular as well as technical name for all rocks which are composed in whole, or to a large extent, of carbonate of lime. Few minerals are so extensively distributed in nature as this, and, in some form or other, limestone rocks occur in every geological system. Carbonate of lime is nearly insoluble in pure water, but it is rendered easily soluble by the presence of carbonic acid gas, which occurs in a variable quantity in all natural waters, for it is absorbed by water in its passage through the air as well as through the earth. Carbonate of lime in solution is consequently found in all rivers, lakes, and seas. In evaporation water and carbonic acid gas are given off, but the carbonate of lime remains uninfluenced, becoming gradually concentrated, until it has supersaturated the water, when a precipitation takes place. In this way are formed the stalactites which hang icicle-like from the roofs of limestone caverns, and the stalagmites which rise as columns from their floors. Travertine (Tiber-stone), or Calcareous Tufa (q.v.), is similarly formed in running streams, lakes, and springs, by the deposition of the carbonate of lime on the beds or sides, where it encrusts and binds together shells, fragments of wood, leaves, stones, &c. So also birds' nests, twigs, and other objects become coated with lime in the so-called petrifying wells, as that at Knarsborough. From the same cause pipes conveying water from boilers and mines often become choked up, and the tea-kettle gets lined with 'fur.'

While water is thus the great storehouse of carbonate of lime, very little of it, however, is fixed by precipitation, for in the ocean evaporation does not take place to such an extent as to permit it to deposit; besides, there is five times the quantity of free carbonic acid gas in the water of the sea that is required to keep the carbonate of lime in it in solution. Immense quantities of lime are nevertheless being abstracted from the sea, to form the hard portions of the numerous animals which inhabit it. Crustacea, mollusca, zoophytes, and foraminifera are ever busy separating the little particles of carbonate of lime from the water, and solidifying them, and so supply the materials for forming solid rock. It has been found that a large portion of the bed of the Atlantic between Europe and North America is covered with a light-coloured ooze, composed chiefly of the perfect or broken skeletons of foraminifera, forming a substance, when dried, which in appearance and structure closely resembles chalk. In tropical regions corals are building reefs of enormous magnitude, corresponding in structure to many of the limestones met with in various geological systems.

The chief varieties of limestone are *Chalk* (q.v.); *Oolite* (q.v.); *Compact Limestone*, a hard, smooth,

fine-grained rock, generally of a bluish-gray colour; *Crystalline Limestone*, a rock which, from metamorphic action, has become granular; fine-grained white varieties, resembling loaf sugar in texture, called *Saccharine* or *Statuary Marble*. Particular names are given to some limestones from the kind of fossils that abound in them, as Nummulite, Hippurite, and Crinoidal limestones; or the presence of impurities or admixtures of other mineral matter may give rise to varieties, as argillaceous, ferruginous, siliceous, carbonaceous, and magnesian limestones. Hydraulic limestones contain a certain proportion of silica and alumina which forms a mortar that sets in water. Many limestones, again, derive their name from the system to which they belong, as Silurian, Devonian, Carboniferous, Jurassic, &c.

Lime-tree. See LIME.

Limfjord. See DENMARK.

Limitation is a term used, in English law, in two senses: (1) A *limitation of property* is a form of words used in a deed or will to mark out the extent of the interests given. Thus, if land be granted to A and his heirs, the words 'and his heirs' are words of limitation; they indicate that an estate of inheritance is given to A.

(2) *Limitation of Actions*.—To protect persons in possession of property, and to prevent the raking up of old disputes, a time is fixed within which actions must be brought. An action to recover land must be brought within twelve years; if the owner allows that time to elapse without asserting his right his title is taken away. Actions to recover debt or damages must be brought within six years; for assault, within four years; for slander, within two years. In Scotland actions to recover land must be brought within forty years; for ordinary debts, within three years; and for bills of exchange, within six years. See PRESCRIPTON; and Boswell's *Statute of Limitations, with English Acts* (Boston, 1889).

Limited Liability. See COMPANY.

Limits, METHOD OF. See CALCULUS.

Limma, an interval which, on account of its exceeding smallness, does not appear in the practice of modern music, but which, in the mathematical calculation of the proportions of different intervals, is of the greatest importance. The limma makes its appearance in three different magnitudes—viz. the great limma, which is the difference between the large whole tone and the small semitone, being in the proportion of 27 to 25; the small limma, which is the difference between the great whole tone and the great semitone, being in the proportion of 135 to 138; and the Pythagorean limma, which is the difference between the great third of the ancients (which consisted of two whole tones) and the perfect fourth, the proportion of which is as 256 to 243.

Limnaeus (Gr. *limne*, 'a swamp'), a genus of pulmonate Gasteropods, living in fresh water in all parts of the world, and feeding on vegetable matter. The shell is thin and pale, capable of containing the whole animal when retracted in danger or buried in the mud during drought. It is a somewhat elongated spire in Limnaeus, coiled in one plane in the allied genus Planorbis, and limpet-like in Ancyclus. An anatomical peculiarity of interest in the adult animal is the persistence on the head region of a structure directly derived from the embryonic 'velum' (see GASTEROPDS). Limnaeus and other fresh-water snails often float and glide shell downwards at the surface with the foot expanded like a boat, the lung sac being partly used as a hydrostatic apparatus. Semper has made numerous experiments on Limnaeus, showing how

they vary in relation to their surroundings. Thus, he was able to rear a dwarf brood by keeping them in confined vessels. Most fresh-water snails come to the surface periodically to breathe the air directly, and then return to their grazing-grounds beneath; some are said to utilise the air-bubbles on water-plants; while others have become adapted to deep water, remain at the bottom, and use skin and lung-chamber as substitutes for gills. More over, in the young forms the lung sac at first contains water. The eggs, enveloped in a glairy substance, are laid on stones or aquatic plants, and afford convenient opportunities for the study of development. Limnaeus is a useful inmate of a fresh water aquarium, keeping the water clean and unchoked by algae. The numerous and prolific species perform a similar function in ponds and streams, and furnish food for fishes and birds. They are often infested by parasites, of which many complete their life-history in higher hosts. Thus, *Limnaeus stagnalis* lodges for a while the Liver-fluke (q.v.) of the sheep.

Limnoria. See BORING-ANIMALS.

Limoges, capital of the French department of Haute-Vienne, and of the former province of Limousin, is picturesquely situated on the Vienne, by rail 248 miles S. by W. of Paris and 218 N. of Toulouse. Its most imposing building is the Gothic cathedral, begun in the 13th century and completed in 1851. The staple industry is the manufacture of porcelain, which employs more than 5000 people. One-half of this product is exported annually to America. The enamel-work, for which Limoges was formerly celebrated, is now no longer carried on. There is a fine ceramic museum (1867). The manufacture of flannel, cotton, paper, &c. are the chief secondary industries. Pop. (1826) 48,862; (1891) 67,817. Limoges was the birthplace of D'Aguesseau, Vergniaud, and Marshals Jourdan and Bugeaud. It was an important town under the Romans, and in spite of plagues, fires, and sieges (the worst that by the Black Prince in 1370), from all of which it has suffered severely, it is still a place of note. It had its own mint from the 4th century down to 1837.

See an article in *Harper's Monthly* for October 1888; the article EXAMEL; and Rupin's *L'Œuvre de Limoges* (1890).

Limon, a port of Costa Rica, founded in 1861, on the Caribbean Sea. The railway begins here, and the place has a landing-pier. There are considerable exports from this place of coffee, caoutchouc, cocoa-nuts, sarsaparilla, vegetables, wood, and hats. Pop. 1400.

Limonite, or BROWN IRON ORE, hydrous ferric oxide. This mineral occurs most frequently in the form of fibrous aggregates, or earthy and amorphous masses, and never in that of definite crystals. It has a hardness of 5.5, a specific gravity of 3.3-3.9, and a yellowish-brown streak. It is the yellow colouring matter of chalybeate springs. Rocks containing iron are often stained brown or yellow from the conversion of the iron into limonite.

Limousin, or LIMOSIN, LEONARD, painter in enamel, was born *cæca* 1505, and flourished from 1532 to 1571 at the French court. He was one of the Limousin school of enamellers. See EXAMEL.

Limpet (*Patella*), a genus of Gasteropod Molluscs, in the Zygobranch section. The animals are most familiar objects between tide marks on rocky coasts, are covered by a conical shell, with the apex directed slightly forward, and remain firmly fixed when the tide is out, adhering by the large oval or circular 'foot,' which acts like a vacuum-sucker on the rock. How firmly they adhere, unless

taken by surprise, every wanderer on the shore has tested, yet the 'oyster-catcher' (*Haematopus*) manages with adroitness to detach them. They move slowly about under water, browsing on crustacean seaweeds with the help of a peculiarly long 'radula' or rasping ribbon, which in the common limpet (*P. calyparus*) is much longer than the body, and bears 160 rows of teeth, 12 in each row, 1920 in all. It is noteworthy that the limpets show a certain local memory, for they return after a short journey to their old resting-places, which, after prolonged usage, may be marked by distinct depressions, especially if the rock be calcareous. The gills form a circle of leaflets between the foot and the edge of the mantle; the internal structure is complex after the fashion of gasteropods; the sexes are distinct, and breed in spring. Limpets are occasionally used for food, but oftener for bait. A species found on the western coast of South America has a shell a foot wide, which is often used as a basin. There are numerous species of *Patella*, and many allied genera, though it is not yet demonstrated that all the forms usually associ-

ated with *Patella* deserve the place which their shells and rasps suggest. The key-hole limpets (*Fissurellidae*) form an adjacent family, marked externally by a hole at or near the apex of the shell, or by a notch on the anterior margin. Another externally similar but more remote set of 'limpets' are united in the family *Acanthidae*, of which *Acanthia testudinaria* is very common on the northern coasts of North America. They are often called 'slipper-limpets,' from the presence of an internal flange on the incipiently spiral shell, and are generally attached, sometimes as commensals, to other molluscs. The genera *Calyptrea* and *Crucibulum*, nearly related to the above, are known as 'cup and-saucer limpets.' For anatomy, see R. J. Harvey Gibson, *Transactions Royal Society, Edin.*, 1884-85.

Limpopo. See OORI.

Limulus. See KING-CRAB.

Linaere. OF LYNAKER.

THOMAS, physician and scholar, was born at Canterbury about 1160, studied at Oxford, and was elected Fellow of All-Souls' College in 1484. Shortly afterwards he went to Italy, where he learned Greek from Chalcondylas and studied under Politian; he graduated in medicine at Padua. About 1501 Henry VII. made him tutor to Prince Arthur and king's physician. This latter office he continued to fill during the reign of Henry VIII. At the same time he practised in London; he also founded the Royal College of Physicians. Late in life he entered the church and held several benefices. He died 20th October 1524. Linaere was one of the earliest champions in England of the New Learning. He translated several of the works of Galen into Latin that was praised for its elegance and purity, and wrote some grammatical treatises the most important, *De Emendata Structura Latini Sermonis* (1524). See Life by Dr Noble Johnson (1835).

Linares. a town of southern Spain, 90 miles by rail ENE. of Cordova, is celebrated for its mines of lead and copper, which yield 40,000 to 50,000 tons of argentiferous ore annually. There are in the town lead and iron foundries, and gunpowder and dynamite factories. Pop. 31,000.

Lincluden. a ruined abbey, $\frac{1}{2}$ mile NNW. of Dumfries, at the Cluden's influx to the Nith. It was founded about 1164 for Benedictine nuns. See McDowall's *Chronicles of Lincluden* (1886).

Lincoln. a city of England, the capital of Lincolnshire, and a parliamentary county, and municipal borough, is situated on the Witham, 42 miles S. of Hull, 33 NE. of Nottingham, and 130 N. by W. of London. Built on the slope of a hill, which rises 210 feet above the river, and is crowned by the cathedral, the city is imposing in effect, and can be seen from afar in the flat fen-country. It is very ancient, is irregularly laid out, and contains many interesting specimens of early architecture—notably the castle, commenced in 1086 by William I.; the Newport Gate, or Roman arch, on the north side of the city; the Exchequer and Stonebow gateways, the latter supporting a guildhall of medieval architecture; the Jew's House (Norman), associated with the legend of Hugh of Lincoln (q.v.); St Mary's Guild (Norman); and the middle grammar-school (to which additions have recently been made), founded in 1567 in the Grey Friars. But

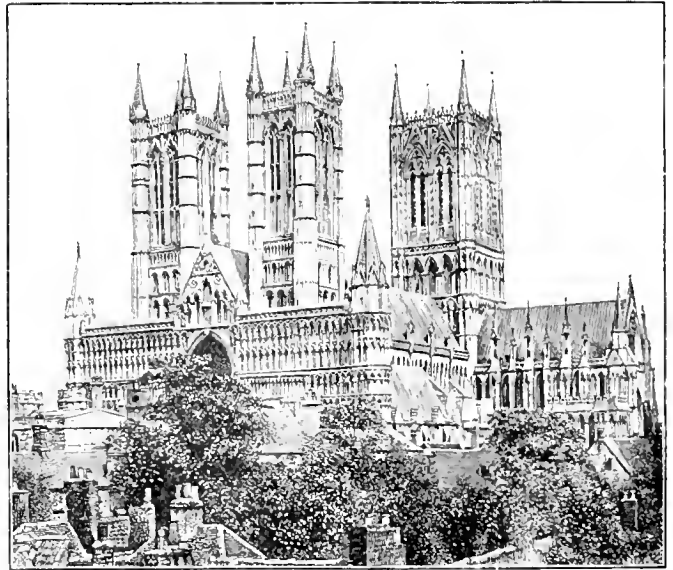

Lincoln Cathedral.

the chief glory of Lincoln is its cathedral, admittedly one of the finest in England. Erected between 1075 and 1501, it measures 524 feet by 82 (or 250 across the transepts), and in style is mainly Early English. Its matchless central tower (1235-1311, and 265 feet high) was previous to 1547 surmounted by a spire, as till 1808 were the two western towers (completed 1150). Other noticeable features are the west front (partly Norman), with its three doorways (1123); the Galilee or south porch (*circa* 1210); the Decorated choir (1254), with its rich sculpturing; the decagonal chapter-house (restored since 1888); Norman font (1075-93); and Great Tom of Lincoln (see article BELL), hung in the central tower, which also contains a mellow-chiming clock (1880). Besides the cathedral, there are fourteen churches of various dates, a county hall (1823-26), theological college, school of science, and bishop's palace (1886-87) embodied with a former palace of 1119. Several iron-foundries and important manufactories of agricultural machinery are in operation here, and an active trade is done in flour. The horse-fair, held annually in the spring, is one of the largest in the world,

and the race-meetings, which take place on the Carholme, date back to at least the reign of James I. One member is returned to parliament for the city, which, moreover, is the depot of the Lincolnshire regiment, and gives the inferior title of earl to the Duke of Newcastle. In the history of Lincoln the most noteworthy incidents have been frequent invasions by the Danes (786-875); great fires (1110 and 1124); a battle (1141) between the adherents of Stephen and the Empress Matilda during their struggle for the English crown; the second coronation of Henry II. (1155-58); an earthquake (1185), which did much damage, especially to the cathedral; the battle of Lincoln, or Lewis Fair, fought 4th June 1218; five parliaments held here between 1301 and 1386; six royal visits; and lastly, the siege of the town, and desecration of the cathedral, by the parliamentarians under the Earl of Manchester (1644). Among the sixty-four bishops of Lincoln were Remigius, who in 1073 transferred the see hither from Dorchester in Oxfordshire; St Hugh of Avalon; Robert Grosseteste; Cardinal Beaufort; Fleming and Smith, the respective founders of Lincoln and Brasenose colleges at Oxford; Cardinal Wolsey; Tenison and Wake, afterwards archbishops of Canterbury; Thurlow, a brother of the Lord Chancellor; and Christopher Wordsworth, the founder of the theological college. Pop. (1801) 7,398; (1831) 11,873; (1881) 37,313; (1891) 43,983. See the works cited at the article LINCOLNSHIRE.

Lincoln. (1) capital of Nebraska, stands in a fertile prairie country, on Salt Creek, 66 miles by rail SW. of Omaha. Laid out in 1867, it is a handsome and thriving city. The public buildings include the state capitol, university, prison, and insane asylum, and the United States court-house. There are numerous manufactories; limestone is largely quarried, and there are great salt works near. Pop. (1880) 13,003; (1890) 55,154.—(2) A town of Rhode Island, 6 miles N. of Providence, comprising several cotton manufacturing villages. Pop. (1890) 20,355.—(3) Capital of Logan county, Illinois, 28 miles NNE. of Springfield, manufactures farm-implements, and is the seat of Lincoln University (Cumberland Presbyterian) and of an imbecile asylum. Pop. 6725.

Lincoln, Mount, a peak of the Rocky Mountains, in Colorado, about 8 miles NE. of Leadville, reaching a height of 14,297 feet. A railway has been constructed to the silver-mining works at the summit, and here is a meteorological station conducted by Harvard College, another station being placed at a lower level (13,500 feet).

Lincoln, ABRAHAM, sixteenth president of the United States, was born in Hardin county, Kentucky, 12th February 1809. He was descended in the sixth generation from Samuel Lincoln, who emigrated from Norwich in England to Massachusetts about 1638. Samuel's grandson removed to Berks county, Pennsylvania, and died there in 1735. The family history henceforward marks the advancing wave of settlements, first south-westward, skirting the eastern slope of the Alleghanies, then surmounting these mountains and spreading over the Ohio valley. Samuel's great-grandson rested in Virginia; his son, Abraham, followed the pioneer Daniel Boone to Kentucky, and while clearing a farm in the forest was killed by Indians in 1784. Abraham's son, Thomas, then but six years old, grew up without education, and in 1806 married Nancy Hanks of the same pioneer stock. Abraham, the future president, was their second child, but lost his mother before he was ten years old. His restless father had crossed the Ohio in 1816, and made a new home in the forests of

Indiana, just before its admission as a state. In 1819 he brought from Kentucky a second wife, Sarah (Bush) Johnston, a worthy woman, who trained her step-children as faithfully as her own. Abraham learned the little that was taught in the backwoods schools, and was employed in rough farm-work until at the age of nineteen he took on a flat-boat a cargo to New Orleans. His first close view of slavery made a lasting impression on his mind.

When Lincoln was twenty-one his father removed to central Illinois, where the son assisted in felling trees, building another log-cabin, and splitting rails for fences. After a second trading voyage to New Orleans he returned to be a clerk in a country store at New Salem, Illinois. When the Indian chief Black Hawk disturbed the northern part of that state in 1832 Lincoln served a few weeks as captain in an uneventful campaign. Being defeated as a candidate for the legislature, he purchased a small store, but its failure left him burdened with debt. However, he was made village postmaster, and also deputy to the county surveyor, and the light duties allowed him time to study law and grammar. Elected to the legislature in 1834, he served until 1842, when he declined further nomination. He had become leader of the Whigs, and was influential in having the state capital removed in 1839 from Vandalia to Springfield, where he had fixed his residence. Thither, too, came Mary Todd (1818-82), the daughter of Robert Todd of Lexington, Kentucky, and in November 1842 she was married to the rising lawyer. In 1846 Lincoln was elected to congress, but his service was limited to a single term. Professional work was steadily drawing him from interest in politics when in 1854 Stephen A. Douglas, by his Kansas-Nebraska bill, repealed the Missouri Compromise of 1820, and reopened the question of slavery in the territories. The bill roused intense feeling throughout the North, and Douglas resolved to defend his position in a speech at the state fair at Springfield in October. Lincoln, invited by his Whig friends to reply, delivered on the same day a speech which first fully revealed his power as a political debater. Against his wish 'Honest Abe' was then elected to the legislature, and the Whigs of that body endeavoured to send him to the United States senate, but finally at his request joined in electing Lyman Trumbull, an anti-Douglas Democrat. When the Republican party was organised in 1856 to oppose the extension of slavery Lincoln was its most prominent leader in Illinois. At its first national convention in the same year the delegates of his state presented him as a nominee for the vice-presidency. But he did not attain a national reputation until 1858. Then Douglas, seeking re-election to the United States senate, began a canvass of Illinois in advocacy of his views of 'popular sovereignty.' Lincoln, as candidate for the same position, arranged with Douglas for a series of debates. The contest attracted the attention of the whole country; but though the general verdict was in favour of Lincoln and his cause, the peculiar arrangement of the legislative districts gave Douglas the immediate advantage, and secured his election.

In another memorable oration in the Cooper Union, New York, in February 1860, Lincoln proved that the founders of the republic had desired the restriction of slavery. In May of that year the Republican convention was held in Chicago, and on the third ballot nominated him for the presidency. The Democratic party held its convention in Charleston, but was unable to agree on a candidate. Douglas was nominated by one wing, Breckinridge by the other. After an intensely exciting campaign Lincoln received a

popular vote of 1,866,462; Douglas, 1,375,157; Breckinridge, 847,953; and Bell, 590,631. Of the electors Lincoln had 180; Breckinridge, 72; Bell, 39; and Douglas, 12.

The pro-slavery leaders forthwith put in execution their plans for the secession of their states. South Carolina moved first, and with the six Gulf states formed, in February 1861, the Confederate States of America. Lincoln, leaving Springfield on 1st February, passed through the principal northern cities, making brief addresses at various points, and reaching Washington on the 24th. His inaugural address on 4th March declared the Union perpetual, argued the futility of secession, expressed his determination that the laws should be faithfully executed in all the states, deprecated the impending evils, and made a touching appeal to all friends of the Union. Of the seven members of Lincoln's cabinet four had been Democrats, three Whigs; two were from border slave-states. The chief places were given to W. H. Seward of New York (secretary of state), and Salmon P. Chase of Ohio (secretary of the treasury). Edwin M. Stanton was made secretary of war in 1862.

On April 12, 1861, the Confederate general Beauregard attacked Fort Sumter in Charleston harbour. The civil war being thus commenced, Lincoln called a special session of congress, summoned 75,000 militia for three months, and ordered the enlistment of 65,000 regulars for three years. He proclaimed a blockade of the southern ports, and endeavoured to make it effective. The Southern Confederacy soon had control of eleven states, and put in the field 100,000 men. The first important battle was fought at Bull Run, Virginia, July 21, 1861, and resulted in a disgraceful rout of the Union army. Further account of the military and naval events of the war belongs to general history. The struggle which sanguine statesmen predicted could be ended in a few months was prolonged over four years, with dreadful sacrifices of men and means. Foreign intervention, which seemed imminent at the outset, was with difficulty averted. After sixteen months, in which the disasters to the Union army had outnumbered the victories, Lincoln declared to Horace Greeley the line of his conduct: 'My paramount object is to save the Union, and not either to save or destroy slavery. If I could save the Union without freeing any slave, I would do it; if I could save it by freeing all the slaves, I would do it; and if I could do it by freeing some and leaving others alone, I would also do that.' One month later the time had come for decision, and on September 22, 1862, just after McClellan's victory at Antietam, Lincoln proclaimed that on and after January 1, 1863, all slaves in states or parts of states then in rebellion should be free. On the following New-year's Day the final proclamation of emancipation was made. This greatest achievement of his administration, wrung from him by the exigencies of civil war, was completed and made immutable by the passage of the Thirteenth Amendment of the Constitution, which he planned and urged, though it was not fully ratified until December 1865.

In July 1863 Grant's capture of Vicksburg restored to the Union full control of the Mississippi River, while Meade's defeat of Lee at Gettysburg destroyed the last hope of the Confederates to transfer the seat of war north of the Potomac. In November of that year, at the dedication of the National Cemetery at Gettysburg, Lincoln delivered a brief address, closing with these words: 'We here highly resolve that these dead shall not have died in vain that this nation, under God, shall have a new birth of freedom and that government of the people, by the people, for the people, shall not perish from the earth.'

General Grant was called to the chief command of the Union army in March 1864, and entered upon that policy of persistent attrition of the Confederate forces which finally brought peace. In the Republican Convention at Baltimore in June Lincoln was unanimously nominated for a second term. The Democrats at Chicago in August declared the war a failure, yet nominated General McClellan. In November Lincoln received of the popular vote 2,216,000, and McClellan 1,800,000; of the electoral votes Lincoln had 212, McClellan 21. In his second inaugural address, in March 1865, Lincoln rose above the ordinary range of such occasions, and like an inspired prophet set forth the profound moral significance of the tremendous war which he saw drawing to a close. A month later he had entered Richmond, from which Grant had driven Davis and Lee. Lincoln returned to Washington to consider the new problems presented by the overthrow of the Confederacy. But his work was already finished. While seeking relaxation with his family at Ford's Theatre he was assassinated by J. Wilkes Booth, an actor, and died on the next morning, April 15, 1865. The national rejoicing over the return of peace was turned into grief for the martyred president. The whole civilised world joined in expression of sorrow for his fate.

Lincoln was 6 feet 4 inches in height, with long limbs and large hands and feet, dark complexion, broad, high forehead, deep-set gray eyes, and coarse black hair. He was slender, wiry and strong, mild and patient, fair and direct in speech and action, scorning all tricks and subterfuges, steadfast in principle, sympathetic and charitable. He was a man of strict morality, abstemious, and familiar with the Bible, though not a professed member of any church. His public life was devoted to the good of his fellow-men, and his fame is established as the saviour of his country and the liberator of a race.

Of his four sons, Robert Todd Lincoln, born August 1, 1843, was the only one to reach manhood. He was secretary of war in the years 1881-85, and was United States minister to England in the years 1889-93.

See Arnold, *The Life of Abraham Lincoln* (1885); Herndon and Weik, *The History and Personal Recollections of Abraham Lincoln* (3 vols. 1889); Nicolay and Hay, *Abraham Lincoln: A History* (10 vols. 1891); J. T. Morse, *Abraham Lincoln* (2 vols. 1893).

Lincoln, BENJAMIN, an American general, was born at Bingham, Massachusetts, 24th January 1733; in 1776 reinforced Washington after the defeat on Long Island, and served with him that year; in 1777 was appointed major-general, was wounded in October, and disabled until the following August; then received command of the southern department, and in 1780 was besieged by Clinton in Charleston, and compelled to capitulate. He was exchanged a year later, took part in the siege of Yorktown, and was deputed to receive Cornwallis' sword. He was secretary of war from 1781 to 1784, and died 9th May 1810.

Lincolnshire, a maritime county of England, and, after Yorkshire, the largest in the country, is bounded on the N. by the estuary of the Humber; E. by the North Sea, the Wash, and Norfolk; S. by Cambridge, Northampton, and Rutland shires; and W. by Leicester, Nottingham, and York shires. Measuring 75 miles from north to south and 48 miles from east to west, it has a seaboard of about 90 miles, and contains 2672 sq. m., or 1,767,879 acres. Pop. (1801) 208,557; (1881) 469,919; (1891) 472,878. The surface is comparatively flat; along the coast stretches a line of low-lying marshes, varying in breadth, from which in places the sea is

only kept out by means of earthen embankments. To the west of these marshes lie the Wolds, a range of chalk downs, which, commencing near Barton-on-Humber in the north, extend thence in a south-easterly direction for about 40 miles to the neighbourhood of Spilsby and Horncastle. The western side of the county, from the Humber in the north through Lincoln to Grantham in the south, consists principally of light uplands, whilst in the south-east are fens forming part of the Bedford Level (q.v.). The efforts to drain the Fens and the Isle of Axholme encountered great opposition from the 'stilt-walkers,' from the reign of Charles I. down to the first quarter of the 18th century. The chief rivers of Lincolnshire, besides that which forms its northern boundary, are the Trent, Witham, and Welland; and a noticeable feature of the county are the numerous canals which intersect it—Car-dyke and Foss-dyke, the two largest, being probably the work of the Romans. Clay, sand, loam, chalk, or peat, varying with the locality, are the prevailing soils. Near Ancaster limestone is extensively quarried, and in the western districts ironstone abounds. The chief crops are corn and turnips, and in places flax is cultivated; but from an agricultural point of view the county is best known for its rich 'warp-lands' along the banks of the Trent, and for the immense flocks of sheep grazed on its pastures. Horse-breeding, too, is extensively prosecuted, the horse-fairs at Horncastle and Lincoln attracting many foreign and London dealers; and amongst other industries may be noted the manufacture of agricultural implements and machinery, and the great shipping trade and fisheries connected with the port of Grimsby.

Lincolnshire is divided into three districts or 'Parts,' as they are called—viz. the Parts of Holland in the south-east, comprising the greater part of the Fens, the Parts of Kesteven in the south-west, and the Parts of Lindsey, which is by far the largest, occupying the remainder of the county. These Parts, each of which has its own county council, are subdivided into thirty-one wapentakes or hundreds, the city of Lincoln and the municipal boroughs of Boston, Grantham, Great Grimsby, and Louth, with part of that of Stamford (the remainder being in Northamptonshire), and contain in all 757 parishes, almost entirely situate in the diocese of Lincoln and midland circuit, the assizes being held at Lincoln. For parliamentary purposes the county is divided into seven divisions, and the boroughs of Boston, Grantham, Grimsby, and Lincoln, each of which returns one member. Other towns are Cleethorpes (practically a suburb of Grimsby), Gainsborough, Sleaford, Spalding, and Sutton.

The history of the county apart from Lincoln is soon told. It was here that in 1536 first broke out the insurrection known as the 'Pilgrimage of Grace,' which had for its object the restoration of popery and re-establishment of dissolved monasteries; and in 1643, during the Civil War, Ancaster, Gainsborough, Grantham, and Winceby were the scene of contests between the rival forces. To the antiquary Lincolnshire is of special interest on account of the beauty of its many churches—Boston, Crowle, Grantham, Heckington, Louth, Long Sutton and Tattershall amongst them; whilst of other places of interest it will suffice to mention here the ruined abbey of Crowland, and Bolingbroke Castle (of which but little remains), the home of John of Gaunt and of his son Henry IV., who was born there. Other eminent persons associated with the county include John Foxe, the martyrologist; William Cecil, Lord Burghley; Captain John Smith; Archedbishop Whitgift; Heywood, the dramatist; Sir Isaac

Newton; Thomas Sutton, founder of the Charterhouse; Dr Busby, head-master of Westminster; John Wesley; Scott, the commentator; Sir John Franklin; Dr Dodd, the forger; Dr Lingard; Lord Tennyson; and Professor Conington. See works by Allen (2 vols. 1834) and Sir Charles Anderson (1880), and Murray's *Handbook to Lincolnshire* (1890).

Lincoln's Inn. See INNS OF COURT.

Lincrusta, a decorative material invented by Walton (see FLOORCLOTH), is a compressed sheet of cellulose, paper, cork, &c., impregnated with linseed oil and resin, and while still plastic, impressed with moulds so as to make raised patterns. It is tough, leathery, impervious to water, and much cheaper than embossed leather.

Lind. JENNY. See GOLDSCHMIDT, MADAME.

Lindau. PAUL, man of letters, was born on 3d June 1839 at Magdeburg. He trained himself for journalistic work in Paris, returned to Germany in 1863, and has since edited various journals, including *Die Gegenwart* and *Noch und Noch*, both of which he founded. He has laboured in three or four other fields of literary activity. Amongst the earliest fruits of his industry were the pleasantly-written books of travel, *Aus Frankfurt* (1864) and *Aus Paris* (1865), and later *Aus der Neuen Welt* (1884). His skill as a writer of critical sketches (in a satirical and humorous manner) is shown in *Humoreske Briefe eines deutschen Kleinwüchters* (1870) and *Literarische Rücksichtslosigkeiten* (1871), and his calibre as a literary critic in studies on *Molière* (1871) and *Alfred de Musset* (1877), and in *Dramaturgische Blätter* (1875-78), *Nächterliche Briefe aus Baiern* (1st and 7th ed. 1876), *Bauernliche Briefe* (5th ed. 1883), and *Anfänge* (1875). But he is perhaps better known as a writer of plays and novels, the subjects of which are taken almost exclusively from modern life. The former possess the merits of lively dialogue and a fair degree of dramatic power; the most successful was perhaps *Maria und Magdalena*. A collection of his theatrical pieces was published in three volumes as *Theater* (1873-81). The novels include *Herr und Frau Bauer* (7th ed. 1882), *Tuppelburg* (3d ed. 1883), *Maja* (5th ed. 1884), a romance cycle, *Berlin* (1886-90), and *Der Bräuer* (1894). He has written works of travel, and in 1895 became manager of the court theatre at Meiningen.

Linden. See LIME.

Lindisfarne. See HOLY ISLAND.

Lindley. JOHN, botanist, was born on 5th February 1799 at Catton, near Norwich. His father, the author of *A Guide to Orchard and Kitchen Gardens*, owned a nursery garden. Botany attracted young Lindley's attention at an early date. When little more than twenty he went to London, and wrote for the *Encyclopædia of Plants*. In 1822 he was appointed assistant-secretary to the Horticultural Society, and in 1829 professor of Botany in University College, London. He retired from this chair in 1860, and died at Turnham Green on 1st November 1865. His works include the *Synopsis of British Flora* (1820); *Introduction to the Natural System of Botany* (1830); *Outline of the Structure and Physiology of Plants* (2 vols. 1832); *Flora Medica* (1838); *The Vegetable Kingdom* (1846), a standard work on the subject of classification; and *Theory and Practice of Horticulture* (2d ed. 1855). Along with W. Hutton he published *The Vessel Flora of Great Britain* (3 vols. 1831-37).

Lindsay, a Scottish historical house of Norman extraction. Sir Walter de Lindsay, settling in Scotland under David I., acquired Errolton in

Berwickshire, and Luffness in East Lothian. His descendant, William Lindsay, Justiciary of Lothian in the 12th century, acquired Crawford in Clydesdale, married Princess Marjory, sister of King William the Lion, and had three sons. The two elder lines of these ended in heiresses, and Crawford eventually came to the descendants of William of Luffness, the third son.

Earls of Crawford and Duke of Montrose.—Sir Alexander Lindsay, younger brother of Sir James of Crawford, the hero of Otterburn, acquired Glenesk and Edzell, and his son David married the sister of Robert III., and was created in 1398 Earl of Crawford. Their chief seat was Finhaven, in Angus. The family attained its climax of power under David, fifth earl, who was made Duke of Montrose in 1488. The grand-nephew of the duke was known as 'The Wicked Master;' and his conduct led his father to transfer the earldom to David Lindsay of Edzell, the next heir. He, however, left it at his death to the son of the 'Wicked Master.' This line ended in the sixteenth earl, and by arrangement, Lord Lindsay of the Byres succeeded to the earldom of Crawford in preference to the descendants of the uncle of the sixteenth earl, who had been created Lord Spynie, and the intermediate cadets of Edzell and Balarres.

Lord Lindsay of the Byres, Viscount Garnock.—Sir William Lindsay, younger brother of the first Earl of Crawford, acquired extensive estates with his wife, a daughter of Sir William Muir of Abercorn. His grandson was made Lord Lindsay of the Byres, county Haddington, in 1445, but their principal residence was Struthers Castle in Fife. The tenth lord was in 1644 created Earl of Lindsay; and, as stated above, under a new patent of Charles I. he became seventeenth Earl of Crawford. He was High Treasurer of Scotland. His grandson by a younger son was created Viscount Garnock in 1703. The fourth Viscount Garnock succeeded as twenty-first Earl of Crawford; and his son, the twenty-second Earl, dying in 1808, was the last of the direct line of the Byres.

Earls of Balarres and Crawford.—The Lindsays of Balarres, in Fife, were a branch, and eventually the representatives, of the Lindsays of Edzell. The first was Lord Menmuir, Secretary of State to James VI. His son David was created Lord Lindsay of Balarres in 1633, and his grandson, Alexander, Earl of Balarres in 1651. On the death of the twenty-second Earl of Crawford, James, seventh Earl of Balarres, became twenty-third Earl of Crawford. A further claim was preferred without success to the dukedom of Montrose, conferred by James III., by the late Earl of Crawford (q.v.). See his *Lives of the Lindsays* (1849), and Jervise's *Land of the Lindsays* (2d ed. 1882).

Lindsay, SIR DAVID. See LINDSAY.

Lindsay OF PITSCOTTIE. See PITSCOTTIE.

Lindsey, PARTS OF. See LINCOLNSHIRE.

Lindsey, THEOPHILUS (1723-1808), one of the first English Unitarians (q.v.), was a native of Middlewich, Cheshire, a Fellow of St John's College, Cambridge, an Anglican clergyman till 1773, and author of several works. See his *Memoirs* by Belsham (1812).

Line, BREAKING THE. See CLERK, JOHN; and TACTICS, NAVAL.

Linens. Flax, like wool, has been used as a material for woven fabrics from a very remote period. Not only are there frequent references to linen in the Bible and other ancient records, but, owing to the wonderful durability of the fibre, many linen mummy-cloths of great age and some of extremely fine texture have been found in Egypt. That country must have been long celebrated for

its linens, because it is known that some of the finest sorts used by the ancient Greeks and Romans were woven on Egyptian looms. Just before the Christian era the cultivation of flax was extensive in Italy, and it was probably by the Romans that the growth of flax for textile purposes was introduced into Britain. Since that time the art of spinning and weaving this fibre by primitive methods has no doubt been continuously practised in countries that were occupied by the Romans, and at all events it can be traced over the greater part of Europe from the 6th or 7th century, till in comparatively recent times it almost entirely ceased to be a domestic industry, and became located in certain centres as an important textile manufacture. Interesting specimens of figured stuffs, such as Damask (q.v.), composed entirely of linen and also of silk and linen, and made in Italy and Spain as early as the 14th century, may be seen in one or two industrial art museums in England and on the Continent. The ground of the celebrated Bayeux Tapestry (q.v.), made in the 11th century, is of linen, which, by means of careful cleaning, is now of an almost snow-white colour.

Flanders seems to have acquired some celebrity for the weaving of table-linen as early as the 11th century, and from that time till long afterwards Flemish weavers were occasionally settling in England. Among the Huguenots, who in the 17th century sought refuge in England and other countries, were many workmen skilled in the making of linen fabrics, and these artisans did much to help this and other industries wherever they settled. A government board of manufactures was established in Ireland in 1711, and another in Scotland in 1727, both of which, by a system of bounties, encouraged the linen trade in several ways. In England the linen manufacture was also assisted by bounties, which did not finally cease till 1832. The year 1787 marks the first introduction of a mill for spinning linen-yarn by machinery in the United Kingdom. It was built at Darlington, and the patentees of the machines were J. Kendrew and T. Porthouse. In Scotland the first flax spinning-mill was erected near Glamis in 1790, and one or two others were set agoing in Fife very soon afterwards. Although the power-loom of Cartwright was applied to the weaving of cotton in 1785, it was not till 1812 that the first factory, which had any real success, for weaving linen by power, was established by C. Turner & Co. of Limehouse, London. Speaking generally, the improvements in the machines for spinning and weaving cotton have been more rapid than in those employed for the manufacture of linen.

Heckling.—The preparation of the fibre of the flax plant into the state in which it is sent to spinning-mills is described under the heading FLAX. At the mill it gets a rough sorting, and is then heckled, a process which has been in use for centuries. A hand heckle is an oblong stock of wood studded with strong steel teeth about 7 inches long in the case of the first or 'ruffer' heckle. The heckler takes a handful or strick of flax by the middle and draws the root end several times through the teeth. He then turns the strick, and in the same way heckles the opposite end. The flax is next similarly treated on a heckle with finer teeth, and if it is to be spun into fine yarn it is further combed on still finer heckles. The object of the process is to separate the flax into two portions, viz. 'line,' which is the long and best portion, and 'tow,' which is the short and ravelled portion. What are called vertical sheet-heckling machines are now extensively employed. This kind of machine consists of endless leather sheets moving over rollers placed at some distance apart with proper driving-gear. A number of

heckle-stocks, placed at regular intervals, are fixed on the surface of these sheets or bands, two of which are placed opposite to, and so near each other that their respective heckle-pins intersect where the actual heckling takes place. At this part of their course the sheets move in a nearly vertical direction downwards, and heckle the flax, which is fixed in a holder and hangs down between the sheets. There are other kinds of heckling-machines.

Preparing.—After the heckling, the flax 'line' is carefully sorted into qualities, and then undergoes a treatment on certain machines called 'preparing.' These are of the same nature as the machines used in the corresponding stages of the spinning of jute, under which head they are briefly noticed; but they will be more fully described under SPINNING. They are (1) the *spreading-frame*, where the flax is first formed into a continuous ribbon or sliver. (2) The *drawing-frames*, on each of which this sliver is 'doubled' and drawn out by rollers through travelling gills with steel teeth, a similar arrangement forming part of the spreading-frame. There are generally three, and occasionally four, drawing-frames, each successive frame having finer gill teeth than the one before it, and from eight to fifteen slivers delivered by one of these machines are drawn out into one sliver by the next. The object of so much doubling and drawing is to produce a sliver of very uniform size throughout, and with the fibres all parallel. (3) The *roving-frame* through which the sliver is passed singly: it is so far similar to the drawing-frame in construction, but with a flyer and bobbin for the now greatly attenuated sliver, which is slightly twisted by the former and wound upon the latter. Flax-tow is carded in the same way as Jute (q.v.), and then goes through the preparing processes just described.

Spinning.—The 'rove' or 'rovings' are spun into yarn on the 'throstle' invented by Arkwright. This machine is also used in spinning cotton, and it does not differ in principle for either fibre (see SPINNING). A peculiarity in flax-spinning is that for all fine yarns the fibre is spun wet—the temperature of the water used being 120° F. By this treatment a given weight of flax can be spun into a much greater length than formerly, and a better yarn is produced. Dry spinning is, however, adopted for coarse and heavy yarns.

Weaving.—The hand-loom is still applied, to some extent, to the weaving of fine linens, but for linen fabrics generally the power loom is in almost universal use. It was found to be a much more difficult task to adapt the power-loom to linen than to cotton owing to the want of elasticity in flax-yarn. The construction of looms is explained under WEAVING, and the bleaching and calendering of linen and other fabrics are described under these several heads.

Linen is manufactured in most European countries, but on the Continent the industry attains much importance only in France, Belgium, and Germany. The neighbourhood of Courtrai in Belgium, and Westphalia in Germany, have long had a reputation for producing yarns of extreme fineness for costly lace. France is celebrated for her cambrics and beautiful damasks. In the United Kingdom the finest linens are made at Belfast and other places in Ulster, the classes of goods made being lawn and cambric handkerchiefs, supple linens, printed linens for dresses, damask table-linen, shirtings, sheetings, and towellings. At Dumfries and several other places in Fife, Scotland, linen damasks, diaper towelling, and plainer fabrics of medium weight are largely manufactured, upholstery linen being chiefly made at Kirkcaldy. Linen goods of similar character are

extensively woven at Bunsley, in Yorkshire. Heavy fabrics, such as sailcloth, canvas, and sacking, are made at Dundee, Arbroath, and a few more Forfarshire towns.

Of our great textile manufactures the making of linen fabrics is the only one that shows signs of becoming a contracting industry. For several kinds of heavy goods it has to compete with jute, and for certain medium and fine fabrics with cotton. Compared with these, linen is a costly textile, and its advantages of strength, glossiness, and, in the fine qualities, of not being easily soiled seem insufficient to keep up the former demand for it for some purposes. The great fault of flax is that the steeping process does not remove all the natural gum in the fibre. It has been stated by experts of high standing that, if the gum could be completely taken out by some inexpensive process, there is no reason why flax should not be spun as easily as cotton. For some fabrics, such as sheetings, which not many years ago were most largely made of linen, cotton, owing to its greater warmth and cheapness, is now preferred; and for others, such as damasks, the two materials are of late years often used together.

The total annual value of the linen manufactures exported from the United Kingdom has for some years past averaged between five and six million pounds sterling.

The manufacture of linen in the United States has never been extensive, the limited quantity of flax grown there being raised more for the seed than the fibre.

Line Spectrum. See SPECTRUM.

Lines of Force. See MAGNETISM.

Ling (*Molva vulgaris*), a fish of the family Gadidae, abundant on most parts of the British coasts, and elsewhere throughout the northern seas, and in value almost rivalling the cod. In form it is much more elongated than the cod, and even more than the hake, with which it agrees in having two dorsal fins and one anal fin, the anal and second dorsal long; but it differs from the hake in having a barbel below the chin, and teeth of unequal size on the jaws and vomer. The ling is generally three or four feet long, sometimes more, and has been known to weigh seventy pounds. The colour is gray, inclining to olive, the belly silvery, the fins edged with white. The tail-fin is rounded. The gape is large, and the mouth well furnished with teeth. The ling is a very voracious fish, feeding chiefly on smaller fishes. It is also very prolific, and deposits its spawn in June; the ova, as usual in the Gadidae, are pelagic. It is found chiefly where the bottom of the sea is rocky. Great numbers are caught in the same manner as cod, by hand-lines and long lines, on the coasts of England, Scotland, the Orkney and Shetland Islands, &c.; considerable numbers are also taken by the trawl. Most of them are split from head to tail, cleaned, salted in brine, washed, dried in the sun, and sent to the market in the form of *Stock-fish*. They are largely exported to Spain and other countries. The air bladders or *souffles* are pickled like those of cod. The liver also yields an oil similar to cod liver oil, which is used for the supply of lamps in Shetland and elsewhere. Two other species of *Molva* from the coasts of Europe have been described.

Ling. PLUR. HENRIK. See GYMNASIUM.

Linga (a Sanskrit word which literally means a sign or symbol) denotes, in the sectarian worship of the Hindus, the Phallus (q.v.), as emblem of the male or generative power of nature. The Linga worship prevails with the Sivaites (see INDIA, p. 106). Originally of an ideal and mystical nature, it has degenerated into practices

of the grossest description; thus taking the same course as the similar worship of the Chaldeans, Greeks, and other nations of the east and west. The manner in which the Linga is represented is generally indolentive—a pillar of stone or other cylindrical objects being held as appropriate symbols of the generative power of Siva. Its counterpart is *Yoni*, or the symbol of female nature as productive. See Muir's *Sanskrit Texts* (vol. iv.), and Kittel's monograph (Basel, 1876).

Lingard, JOHN, historian, was born at Winchester, 5th February 1771. Both his parents were Lincolnshire Catholics, his father a carpenter, his mother the daughter of a respectable farmer who had been ruined by the penal laws. A promising boy, he was sent in 1782 by Bishop Talbot to the English College of Douay (q.v.), where he remained till in 1793 it was broken up by the Revolution. The Catholic Relief Act enabling Catholics to open schools in England, the Douay community was transferred first to Crook Hall, near Durham, and in 1808 to Ushaw. Lingard, who had accepted the office of tutor in Lord Stourton's family, in 1794 resumed his theological studies, and, next year receiving priest's orders, became vice-president of the college, prefect of the studies, and professor of Philosophy. In 1811 he accepted the secluded mission of Hornby, near Lancaster, declining the offer of the presidency of Maynooth, as fourteen years later of a cardinal's hat; and here he 'grew old in illustrious obscurity.' He twice visited Rome, in 1817 and 1825; in 1821 obtained his doctorate from Pius VII.; and in 1830 received a crown pension of £300. He died at Hornby, 17th July 1851, and was buried in the cloister at Ushaw. His first important work, the *Antiquity of the Anglo-Saxon Church* (2 vols. 1806; 5d and much enlarged ed. 1845), was but the pioneer of what eventually became the labour of his life—a *History of England to 1688* (8 vols. 1819-30; 6th ed. 10 vols. 1854-55). This from the outset attracted much attention; and the first two editions brought its author £4133. It was fiercely assailed in the *Edinburgh Review*; but Dr Lingard in his reply displayed so much erudition, and so careful a regard for original authorities, that the result was to add materially to his reputation as a scholar and a critic. The chief mark of its Catholic origin is not seldom the absence of Protestant bias and prejudice; still, it is as declaring the views of a candid and judicious Catholic that the later volumes retain a permanent value. The earlier volumes have been largely superseded. For Lingard's minor writings, which were numerous, see the Memoir by Canon Tierney, prefixed to vol. x. of the 6th ed. of the *History*.

Lingua-Franca, the corrupt Italian which has been employed, since the period of the Genoese and Venetian supremacy, as the language of commercial intercourse in the Mediterranean, especially the Levant. Any language which serves a similar purpose, as, for instance, Swahili and Hausa in Africa, and the Chinook jargon in the north-west of the United States, is called generally a *Lingua-franca*. Compare 'pigeon English,' under CHINA.

Lingula, a genus of Brachiopoda (q.v.).

Lingula Flags. See CAMBRIAN SYSTEM.

Liniments (from the Latin word *linire*, 'to besmear') may be regarded, in so far as their physical properties are concerned, as ointments having the consistence of oil, while, chemically, most of them are *soaps*: that is to say, compounds of oils and alkalies. In consequence of their slighter consistence, they are rubbed into the skin more readily than ointments. Among the most important of them are: *Liniment of Ammonia*, popularly known

as *Hartshorn and Oil*, which is prepared by mixing and shaking together solution of ammonia and olive-oil, and is employed as an external stimulant and rubefacient to relieve neuralgic and rheumatic pains, sore throat, &c.; *Soap Liniment*, or *Opodeldoc*, the constituents of which are soap, camphor, and spirits of rosemary, and which is used in sprains, bruises, rheumatism, &c.; *Liniment of Lime*, or *Carron Oil*, which is prepared by mixing and shaking together equal measures of olive or linseed oil and lime water; it is an excellent application to burns and scalds, and from its general employment for this purpose at the Carron iron-works has derived its popular name: *Camphor Liniment*, consisting of camphor dissolved in olive-oil, which is used in sprains, bruises, and glandular enlargements, and which must not be confounded with *Compound Camphor Liniment*, which contains a considerable quantity of ammonia, and is a powerful stimulant and rubefacient; and the *Opium Liniment*, which consists of soap liniment and tincture of opium, and is much employed as an anodyne in neuralgia, rheumatism, &c. These are the chief liniments according to the old definition, but the term has gradually come to be applied to tinctures intended for external use. Such are the liniments of aconite, belladonna, cantharides, iodine, &c., which are made by treating the drugs with alcohol, and thus obtaining a concentrated tincture.

Linköping, one of the oldest towns in Sweden, capital of East Gothland and the seat of its bishop, stands $3\frac{1}{2}$ miles S. of Lake Roxen and 142 miles by rail SW. of Stockholm. The Romanesque cathedral, which dates from the 12th century, is one of the finest churches in Sweden. Since 1887 Linköping has had direct communication for vessels with the Baltic, and now exports timber and gilded mouldings. Pop. (1875) 8112; (1890) 12,649.

Links. See GOLF.

Linley, THOMAS, English musical composer, was born at Wells in 1732. He first gained a reputation at Bath as teacher of singing and conductor of the concerts in the Assembly Rooms. But in 1775 his son-in-law Sheridan induced him to compose great part of the music for his opera *The Duenna*, and persuaded him to go to London to superintend its performance. In the following year the two, in conjunction with R. Ford, bought Garrick's share of Drury Lane Theatre. During the next fifteen years Linley was musical director of this theatre, composing numerous occasional pieces and the music of the operas *Gentle Shepherd* (1781), *Carnival of Venice* (1781), *Selima and Azor* (1784), *Strangers at Home* (1786), *Love in the East* (1788), &c. Linley's name stands highest, however, as a composer of music for songs and elegies—it is simple, sweet, melodious, and yet lively. He died in London on 19th November 1795. —Two of his sons inherited his musical talent, THOMAS (1756-78), who possessed real genius and was a friend of Mozart in Italy, and WILLIAM (1767-1835), who composed a number of glees, songs, &c.

Linlithgow, an ancient royal burgh, the county town of Linlithgowshire, lies 16 miles W. of Edinburgh, near the southern shore of Linlithgow Loch, which, 150 feet above sea-level, covers 102 acres, and deepens westward from 10 to 50 feet. On a promontory, 66 feet high, stands the stately ruin of Linlithgow Palace, mostly rebuilt between 1425 and 1628, and fired by Hawley's dragoons in 1746. It was the birthplace of James V. and Mary Stuart. The neighbouring parish church of St Michael's is a very good Decorated structure of mainly the 15th and 16th centuries; within its south transept James IV. received the Flodden

warning. Another event in Linlithgow's history was the murder of the Regent Moray. The Cross Well (rebuilt in 1807) and the new town-hall (1889) are also noteworthy. With Falkirk, &c., Linlithgow returns a member. Pop. (1881) 3187; (1891) 4155. See Wadlie's *History of Linlithgow* (3d ed. 1879).

Linlithgowshire, or WEST LOTHIAN, a Scottish county, washed on the north for 17 miles by the Firth of Forth, and elsewhere bounded by Edinburgh, Lanark, and Stirling shires. Its length south-westward is 22 miles, its average breadth 7 miles, and its area 127 sq. m. The only large streams are the Almond on the south-eastern, and the Avon on the western boundary; and the principal eminences are Cairnmaple (1016 feet), Cocklerue (912), Deilmont Law (686), and Glower-o'er-em (559), the last with a monument to General Adrian Hope, who fell in the Indian Mutiny. The rocks are carboniferous, with igneous intrusions; and coal has been largely mined since the 12th century, as also are ironstone, fireclay, and shale. Excellent sandstone is quarried at Binny. The soil is generally fertile, except to the south and south-west, where it is moorish or rocky; and as much as 73 per cent. of the whole area is in cultivation, whilst woods cover 4982 acres. Towns, noticed separately, are Linlithgow, South Queensferry, Bathgate, Boness, and Broxburn; among the mansions are Hopetoun, Dalmeny, Dundas, and Kinneil; and the antiquities include prehistoric and Roman remains, the Romanesque church of Dalmeny, the castles of Barnbougle, Blackness, Niddry, &c., and the preceptory at Torphichen of the Knights of St. John. The county returns one member to parliament. Pop. (1801) 17,844; (1841) 26,872; (1891) 52,808. See Sibbald's *History of Linlithgowshire* (1710), and Small's *Castles and Mansions of the Lothians* (1883).

Linnaea. See CAPRIFOLIACEÆ.

Linnaeus, CARL, ennobled in 1757 as CARL VON LINNÉ, the founder of modern botany, was born at Råshult, in the Swedish province of Småland, on 23d May 1707. His father, the rector of the parish, destined him for his own profession, the church. But whilst still a child Carl showed a passion for flowers. He was sent to school at Wexjö, then passed on to Lund (1727) and Upsala universities to study medicine; but his real study was botany. In 1730 he was appointed assistant to the professor of botany in Upsala. The greater part of 1732 was occupied in executing a commission from the Upsala Academy of Sciences—an exploring trip through Swedish Lapland, the botanical results of which were published as *Flora Laponica* in 1737. His diary of this journey was translated into English and published by Sir J. E. Smith in 1811 as *Luchesis Laponica*. Then followed a journey of scientific exploration and survey through the province of Dalecarlia. In 1735 he went abroad to take his doctor's degree at Harderwijk in Holland. Passing on to Leyden and Amsterdam, he found encouragement in Gronovius, to whom he showed the MS. of the *Systema Naturæ*, and helpful patronage in Boerhaave, who introduced him to the wealthy Dutch banker, Clifford. Clifford, who had a magnificent garden and greenhouses and botanical collections, employed the young Swede to arrange them for him. It was the autumn of 1737 before he was done with the work. But in the meantime he had paid a visit to England, and published some of his most famous books, such as the *Systema Naturæ*, *Fundamenta Botanica*, *Genera Plantarum*, *Critica Botanica*, in which he expounded his celebrated system of classification, based on differences in sexual characteristics. This system of Linnaeus, although intentionally an artificial

one, was predominant for a long time in the botanical schools of Europe (see BOTANY). On his way home he was tempted to stay nearly a year at Leyden to help to arrange the botanical garden belonging to the university. Then he paid a flying visit to Paris, where he became acquainted with Bernard and Joseph de Jussieu. On reaching home he practised as a physician in Stockholm for three years with brilliant success. In 1741 he was appointed professor of Physics and Anatomy at Upsala, but exchanged this chair for that of Botany in the following year. With this post was combined the directorship of the botanical gardens. During the many years that Linnaeus taught botany his fame and his lectures increased the number of pupils attending the university from five to fifteen hundred. The years 1745-46 were marked by the publication of the *Flora Suecica* and *Fauna Suecica*, the latter embodying the results of fifteen years' labour; 1751 by the *Philosophia Botanica*; and 1753 by the appearance of *Species Plantarum*, in which he first fully established the custom of using a second or trivial name in addition to the generic name, by which to identify a plant. Just previous to his appointment as professor he conducted a scientific journey through the islands of Öland and Gotland, in 1746 a similar journey through the province of West Gothland, and in 1749 another in the province of Skåne, of all of which he wrote descriptive accounts in Swedish. Linnaeus died on 10th January 1778. See *Through the Fields with Linnaeus*, by Mrs Florence Caddy (2 vols. 1887), which supersedes the *Life* (Eng. trans. 1794) by Stoeber.

The LINNEAN SOCIETY was formed in London in 1788, and obtained a royal charter in 1802. Its founder and first president was Sir J. E. Smith, who purchased the books and MSS. and botanical collections of Linnaeus after the death in 1783 of the great botanist's son, and from whom they passed into the hands of the society in 1828.

Linnell, JOHN, artist, was born in London in 1792, in 1805 entered as a student at the Royal Academy, and distinguished himself greatly during his course, not only in painting, but in sculpture and engraving. He was a pupil of Benjamin West and Varley, and himself taught drawing to Mary Wollstonecraft Shelley. He painted many portraits of eminent men, as his friend Blake, Malthus, Whately, Peel, and Carlyle. His landscapes were mostly painted from the sweet scenery of Surrey. Of these need only be named 'Harvest Showers,' 'A coming Storm,' 'Autumn,' and 'The Heath.' Linnell died at Redhill, January 20, 1882. See his *Life* by A. T. Story (1892).

Linnet (*Acanthis*), a genus of Passerine birds in

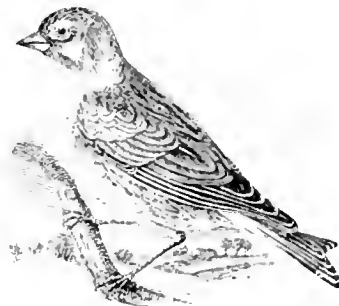

Linnet (*Acanthis cannabina*).

the finch family Fringillidae, familiarly represented by the Grey, Red, or Rose Linnet (*Acanthis*

cannabina). This bird is common in Britain, and widely distributed in Europe and in north-west Africa. It is rather under 6 inches in length, and exhibits, as its common names suggest, a marked seasonal change of plumage. It feeds on soft seeds, and breeds in spring. The nest, made of soft stems and moss, lined with wool and down, is especially common in furze and other low bushes. The eggs (4 to 6) have a bluish-white ground, speckled with reddish brown or purplish red; two broods may be reared in the season. The linnet or 'lutic' sings well, is amenable to education, and is but too often caged. In the mountain-regions of Scotland it is represented by the *Turd* or Mountain-linnet (*A. flavirostris*), while other British species are the Mealy Redpole (*A. linaria*) and the Lesser Redpole (*A. rufescens*), the smallest of British finches. The Green Linnet is the Greenfinch (*Ligurianus chloris*).

Linoleum. See FLOORCLOTH.

Linseed, the seed of flax, largely imported from the Continent and India, for making *linseed-oil* and *oil-cake*. In making these the seeds are first bruised or crushed, then ground, and afterwards subjected to pressure in a hydraulic or screw press, sometimes without heat, and sometimes with the aid of a steam heat of about 200° (93·4 C.). *Linseed-oil* is usually amber-coloured, but when perfectly pure it is colourless. It has a peculiar and rather disagreeable odour and taste. It is chiefly used for making varnishes, paints, &c. That made without heat (*cold-drawn linseed-oil*) is purer, and less apt to become rancid, than that in making which heat is applied. By cold expression the seed yields from 18 to 20 per cent., and with heat from 22 to 27 per cent. of oil. *Linseed-oil* boiled, either alone or with litharge, white lead, or sulphate of zinc, dries much more rapidly on exposure to the air than the unboiled oil; and *boiled* or *drying oil* is particularly adapted for many uses.—The Oil-cake (q.v.) made in expressing linseed-oil is very useful for feeding cattle. *Linseed* itself is excellent food for cattle and for poultry. The seed coats abound in mucilage, which forms a thick jelly with hot water, and is very useful for fattening cattle.—*Linseed-meal*, much used for poultices, is generally made by grinding fresh oil-cake, but it is better if made by grinding the seed itself.

Lint was the name given to linen cloth or rags when shredded or scraped down so as to form a soft material, suitable for dressing wounds and soaking up discharges. This is now superseded by a cotton cloth specially woven for the purpose, with one side soft and fluffy. See also FLAX.

Linton, SIR JAMES DRUMGOLE, water-colour and oil painter, was born in London, 26th December 1810. He laboured with success to elevate the status of his favourite branch of art, painting in water-colours; and in 1883 the Institute of Water-colour Painters, of which he had been elected a member in 1867, was reorganised, its title being henceforth the Royal Institute of Painters in Water-colours, and its exhibitions being thrown open to everybody, not confined, as hitherto, to members. Linton himself was chosen president in 1881, and in the following year was knighted. His most successful pictures are those of single figures. As a painter in oil his most notable productions are the 'Marriage of the Duke of Albany,' painted by royal command in 1885, and a series illustrative of the 16th century for a private house at Nottingham.

Linton, WILLIAM JAMES, wood-engraver and author, was born in London in 1812. As a wood-engraver he may be said to be the most artistic who ever lived. Some of his finest work may be

found in the pages of the *Illustrated London News*, to which he frequently contributed, from its commencement till he finally went to the United States in 1867. As an author, the zealous chartism of his youth tinged much of his work. Among his various works may be mentioned *The Plain of Freedom* (1852), *Charibel and other Poems* (1865), several volumes of *The English Republic*, *Some Practical Hints on Wood-engraving* (1879), *Life of Thomas Paine* (1879), *A Manual of Wood-engraving* (1884), *Poems and Translations* (1889), and *The Masters of Wood-engraving* (1890). He died 29th Dec. 1897. See his *Memoirs* (1895).—His wife, ELIZA LYNN, born at Keswick, 10th Feb. 1822, had published her first novel a dozen years before their marriage in 1858. Together they prepared a volume on *The Lake Country* (1861), he furnishing the illustrations and she the letterpress; in 1867 they separated. Mrs Lynn Linton was an indefatigable worker, and her novels were many: *The True History of Joshua Davidson* (1872) and *The Autobiography of Christopher Kirkland* (1885) are of heavier calibre than the rest. She did a great deal of magazine work, and her 'Girl of the Period' articles in the *Saturday Review* appeared in a collected form in 1883. She died in London 14th July 1898.

Linz, capital of the crown-land of Upper Austria, is situated on the right bank of the Danube, which is here crossed by an iron bridge 780 feet long, 117 miles by rail W. of Vienna. Pop. (1890) 47,685. It has a splendid new Gothic cathedral (1862-90), the old cathedral church (1670), the bishop's palace, the national museum, a library of 33,000 vols., a bishop's seminary, a commercial school, &c. Owing to its situation on the Danube and to its being an important railway centre, Linz is a busy commercial place; its industries include the manufacture of woollen goods, tobacco, linen, leather, machinery, &c. Shipbuilding is likewise carried on. As a place of some strategic importance Linz has been besieged on several occasions, notably by the peasants in 1626, and during the war of the Austrian succession in 1741 and again in 1742. Here peace was signed between the Emperor Ferdinand III. and George Rakoczy of Transylvania in 1645, and in the vicinity Bernadotte defeated the Austrians in 1809. See works by Krackowizer (1875) and Hiptmair (1885).

Lion (*Felis leo*), the largest and most majestic of the Felidae. It is, when mature, of a nearly uniform tawny or yellowish colour, paler on the under parts; the young alone exhibiting spots like those common in the Felidae. The male has usually a great shaggy and flowing mane; and the tail, which is pretty long, terminates in a tuft of hair. The whole frame is extremely muscular, giving, with the large head, bright flashing eye, and copious mane, a noble appearance to the animal, which, with its strength, has led to its being called the 'king of beasts,' and given rise to fancies of its noble and generous disposition, having no foundation in reality. A lion of the largest size measures about 8 feet from the nose to the tail, and the tail about 4 feet. The lioness is smaller, has no mane, and is of a lighter colour on the under parts. The strength of the lion is such that he can carry off a heifer as a cat carries a rat.

The lion is an inhabitant of the tropical and subtropical regions of Africa and Asia. It was anciently much more common in Asia, and was found in some parts of Europe, particularly in Macedonia and Thrace, according to Herodotus and other authors. The Cave Lion (*Felis spelæa*), whose bones are met with in cave-deposits of England and the Continent, hardly differs from *Felis leo*. The lion is not in general an inhabitant of deep forests,

but rather of open plains, in which the shelter of occasional bushes or thickets may be found. The breeding-place is always in some much secluded retreat, in which the young—two, three, or four in a litter—are watched over with great assiduity by



Lion (*Felis leo*)

both parents, and, if necessary, are defended with great courage—although, in other circumstances, the lion is more disposed to retire from man than to assail him or contend with him. When met in an open country the lion retires at first slowly, as if ready for battle, but not desirous of it; then more swiftly; and finally by rapid bounds. If compelled to defend himself he manifests great courage. The lion often springs upon his prey by a sudden bound, accompanied with a roar; and it is said that if he fails in seizing it he does not usually pursue, but retires as if ashamed; it is certain, however, that the lion also often takes his prey by pursuing it, and with great perseverance. The animal singled out for pursuit, as a zebra, may be swifter of foot than the lion, but greater power of endurance enables him to make it his victim. Deer and antelopes are perhaps the most common food of lions. The lion, like the rest of the Felidae, is pretty much a nocturnal animal; its eyes are adapted for the night or twilight rather than for the day. It has a horror of fires and torch-lights; of which travellers in Africa avail themselves, when surrounded by prowling lions in the wilderness by night, and sleep in safety. Lions rapidly disappear before the advance of civilisation. In India they are now confined to a few wild districts; and in South Africa their nearest haunts are far from Capetown and from all the long and fully settled regions.

The mane of the lion, and the tuft at the end of the tail, are not fully developed till he is six or seven years old. The tail terminates in a small prickle, the existence of which was known to the ancients, having been discovered by Diodorus Alexandrinus, one of the earliest commentators on the *Iliad*; it was supposed by them to be a kind of goad to the animal when lashing himself with his tail in rage. The prickle has no connection with the caudal vertebrae, but is merely a little nail or horny cone, about two lines in length, adhering to the skin at the tip of the tail. It has been stated to occur also in the leopard.

There are several varieties of the lion, slightly differing from each other in form and colour, but particularly in the development of the mane. The largest lions of the south of Africa are remarkable for the large size of the head and the great and black mane. The Persian and other Asiatic lions are generally of a lighter colour, and inferior in size, strength, and ferocity to the African lion. Guzerat and the south of Persia produce a some-

what smaller variety, remarkable as being almost destitute of mane.

The lion is easily tamed, at least when taken young, and when abundantly supplied with food is very docile, learning to perform feats which excite the admiration of the crowds that visit menageries. The greatest of lion-tamers, Van Amburgh, died in his bed at Philadelphia, 29th November 1865; still, exhibitions of this kind are not unattended with danger, as too many instances have proved. Lions were made to contribute to the barbarous sports of the ancient Romans; a combat of lions was an attractive spectacle, and vast numbers were imported into Rome, chiefly from Africa, for the supply of the amphitheatre. Pompey exhibited 600 at once. Lions were kept in the Tower of London from the 13th century till 1834; and one died here in 1770 after seventy years' confinement. They have not unfrequently bred in the menageries of Europe (with particularly good results in the Dublin Zoological Gardens), and a hybrid between the lion and the tiger has occasionally been produced. For the lion in herakdry, see ILLUSTRATION.

Leonardo da Vinci. See LEONARDO.

Lions, GULF OF (*Golfe du Lion*), the large gulf of the Mediterranean on the south of France, extends from the frontier with Spain eastwards to the Hyères Islands.

Lipari Islands, known also as the **ÆOLIAN ISLANDS**, a volcanic group in the Mediterranean, consisting of half-a-dozen larger and numerous smaller islands, with an aggregate area of 116 sq. m., and situated off the north coast of Sicily, north-west of Messina. They rise to 3170 feet above the level of the sea; many of the smaller islands form part of the rim of a gigantic crater. The ancient classical poets localised in these islands the abode of the fiery god Vulcan—hence their ancient name, *Vulcani Insulae*. Their collective population is 18,000, of whom nearly 8000 belong to the island of Lipari (area, 32 sq. m.), the most important of the group. The next in size are Vulcano, Stromboli, Salina, Filicudi, Alicudi, and Panaria. The principal products of the islands are grapes, figs, olives, wine (Malmsay), borax, pumice-stone, and sulphur. The warm springs are much resorted to, and the climate is delightful. Lipari, the chief town, is a bishop's see and a seaport, and has 4968 inhabitants. Stromboli (3022 feet) is almost constantly active; Vulcano (1017 feet) is so intermittently; the rest are extinct.

Liparite, an igneous rock, so called from its occurrence in the island of Lipari. It has a wide geographical distribution, and is also known as Rhyolite and Quartz-trachyte. It is a highly acid rock, and has a glassy base, often more or less devitrified. Throughout this base are scattered quartz, sanidine, plagioclase, and biotite; and other minerals may also be present. The more compact varieties often exhibit sphenoidal and fluxion structures, which occasionally impart a kind of laminated or banded aspect to the rock. Other varieties of texture range from compact up to coarse-grained and granitoid.

Lipetzki, a town in the Russian government of Tamboff, on the right bank of the Voronezh, a tributary of the Don, and 300 miles by rail SSE. from Moscow, was founded in 1700 by Peter the Great, but only began to flourish at the commencement of the 19th century, when the admirable qualities of its chalybeate springs became known. It has a large annual influx of visitors during summer. Pop. (1894) 15,860.

Lipogram (Gr. *λίπος*, 'I leave out,' and *γράμμα*, 'a letter') is a species of verse charac-

terised by the exclusion of a certain letter, either vowel or consonant. The earliest known author of lipogrammatic verse was the Greek poet Lasus (born 538 B.C.); and it is recorded of one Tryphiodorus, a Græco-Egyptian writer of the same period, that he composed an *Odyssey* in 24 books, from each of which, in succession, one of the letters of the Greek alphabet was excluded. Fabius Claudius Gordianus Fulgentius, a Christian monk of the 6th century, performed a similar feat in Latin. In modern times the Spaniards have been most addicted to this laborious frivolity. Lope de Vega wrote five novels, from each of which one of the vowels is excluded; and several French poets have also practised the trick. See Henry B. Wheatley's book on *Anagrams* (1862).

Lippe, or, as it is generally called, but incorrectly, LIPPE-DETMOLD, a small principality of northern Germany, lying between Westphalia on the W. and Hanover on the E. The Weser touches it on the N. and the Tentoburger Wood crosses it in the S. Area, 475 sq. m.; pop. (1875) 112,442; (1890) 128,495, of whom only 4332 were Catholics. The present constitution of Lippe dates from 1853; capital, Detmold (q.v.); other towns, Lemgo and Horn. The surface is hilly; woods cover 28 per cent., and are well cared for. The principal occupation is agriculture, with the rearing of cattle and swine. The products of these callings, with timber, salt, meerschaum pipes, tobacco, and starch, are the chief results of the industrial activity exported. Every spring some 12,000 of the inhabitants spread themselves over central Europe, as far as south Russia, to burn bricks, and return home in the autumn. The little country is governed by an administrative college, and a House of (twenty-one) Representatives, elected directly by the people, who are for that purpose divided into three classes. The princes of Lippe belong to one of the oldest sovereign families of Germany, and can be traced back to the 10th century. The first who took the name of count of Lippe was Bernhard in 1129. The family split into three branches in 1613—Lippe, Brake, and Schaumburg. The second of these became extinct in 1799. For the third, see SCHAUMBURG-LIPPE. See historical works (1847-87) by Falkmann.

Lippi, FRA FILIPPO, commonly known as LIPPO LIPPI, a Florentine painter, was born in 1412; but, losing his parents whilst still an infant, he was entrusted to the Carmelite friars of Florence when only eight years of age. In the story of his life as told by Vasari there are several romantic incidents; but most of them are now discredited, except that he abducted Lucrezia Buti, a ward or novice of the convent of St Margaret at Prato, and afterwards married her. Lippo Lippi, who studied principally Masaccio, painted religious subjects, which he conceived and designed from a human standpoint. His greatest work was done on the choir walls of the cathedral of Prato—illustrations of the lives of John the Baptist and St Stephen. He was busy executing a series of incidents from the life of the Virgin in the cathedral apse at Spoleto, when death arrested his hand for ever, about 8th October 1469. Besides these works he painted several Madonnas and altarpieces, amongst these last one for the nursery chapel of S. Ambrogio, Florence, the subject of Browning's poem. Lippo Lippi had a staunch patron in Cosimo de' Medici. See Crowe in *Nineteenth Century*, 1896.

His son, FILIPPINO LIPPI, was born at Florence in 1460, and educated at Prato. His artistic style has a strong element of originality, but also shows the influence of his father and Botticelli. His most celebrated frescoes are scenes from the lives of St Peter and St Paul in the Brancacci chapel at

Florence (cf. MASACCIO), incidents illustrating the character of St Thomas Aquinas in the Minerva church at Rome, and subjects from the legends of St John and St Philip in Sta Maria Novella at Florence. His best easel-pictures include 'The Virgin and Saints' (in the Uffizi at Florence), 'The Adoration of the Magi,' 'The Vision of St Francis.' Filippino died in April 1504 at Florence.

Lippincott, JOSHUA BALLINGER, an American publisher, was born of Quaker parents in Burlington, New Jersey, in 1816, had charge of a bookseller's business in Philadelphia from 1834 to 1836, when he founded the house of J. B. Lippincott & Co., and by 1850 was at the head of the book-trade in Philadelphia. He died January 5, 1886, and the firm was converted into the J. B. Lippincott Company, the authorised American publishers of the present edition of this work. *Lippincott's Magazine* was established in 1868.

Lippstadt, a town of Prussia, on the river Lippe, 30 miles E. by N. from Dortmund. It has manufactures of spirits, beer, cigars, brushes, ropes, iron, &c. Founded in 1168, it was captured by the Spaniards in 1620, and by the French in 1757. Pop. 11,504.

Lipsius, RICHARD ADELBERT, a great German theologian, was born at Gera, February 14, 1830, studied theology at Leipzig, and, after serving there as *privat-docent* and professor extra-ordinary, was called to fill a chair at Vienna in 1861, at Kiel in 1865, and at Jena in 1871. He died 19th August 1892. Lipsius made contributions of the greatest importance to theological science in the fields of dogmatics and the history of dogma, the philosophy of religion, and New Testament exegesis and criticism. In 1875 he founded the *Jahrbücher für Protest. Theologie*. Among his books are *Glaube und Lehre* (1871), *Die Quellen der Rom. Petrusfrage* (1872), *Lehrbuch der Evangelisch-Protest. Dogmatik* (1876), *Die apokryphen Apostelgeschichten und Apostellegenden* (1883-87), and *Philosophie und Religion* (1885).—Of his brothers, JUSTUS HERMANN (born at Leipzig, 9th May 1834) is eminent as a philologist. After teaching at Leipzig, Meissen, Grimma, he became in 1869 extra-ordinary professor of Classical Philology at the university of Leipzig, and in 1877 ordinary professor of the same, and director of the Russian philological seminary. His books are an edition of the *In Corona* of Demosthenes (1876), and of Meier and Schömann's work, *Der Attische Prozess* (1883-85). He also collaborated with Curtius, Lange, and Ribbeck in the well-known *Leipziger Studien*, established in 1878. Their sister MARIE (born at Leipzig, 30th December 1837) has made valuable contributions to music and its history, under the pseudonym of La Mara, the most important being *Musikl. Studienkopfe* (5 vols. 1868-82), *Gedanken bewahrter Musiker über ihre Kunst* (1873), and a German translation of F. Liszt's *Chopin* (1880).

Liqueur. This name is given to the very numerous alcoholic preparations which are flavoured or perfumed and sweetened to be more agreeable to the taste. *Anisced Cordial* is prepared by flavouring weak spirit with aniseed, coriander, and sweet fennel seed, and sweetening with finely-clarified syrup of refined sugar. *Chore Cordial* is flavoured with cloves, bruised, and coloured with burnt sugar. *Kummel* (a Russian and German liqueur, named from the German name of the herb cummin) is made with sweetened spirit, flavoured with cummin and caraway seeds, the latter usually so strong as to conceal any other flavour. It is chiefly made at Riga. *Maraschino* is distilled from cherries bruised, but, instead of the wild kind, a fine delicately-flavoured variety called *Marasques* are used in Dalmatia. *Noyau*, or *Crème de Noyau*, is a sweet

cordial flavoured with bruised bitter-almonds. *Pep-permint* is usually sweetened gin, flavoured with essential oil of peppermint. *Chartrons*, *Cacagna*, and *Kirschwasser* have separate articles. *Benedictine* is made at Fécamp. *Absinthe* (q.v.) is not a liqueur; *Vermouth* is alcoholised white wine, aromatised with wormwood, gentian, angelica, germander, and oranges. Cherry Brandy and Sloe Gin are sweetened spirits flavoured with cherries and sloes.

Liquidambar, a genus—the only genus—of the order Altingiaceæ. They are tall trees, remarkable for their fragrant balsamic products. *L. styraciflua*, the American Liquidambar, or Sweet Gum tree, is a beautiful tree with palmate leaves, a native of Mexico and the United States. It grows well in the milder parts of Britain. Its wood is of a hard texture and fine grain, and makes good furniture. From cracks or incisions in the bark a transparent, yellowish balsamic fluid exudes, called *Liquid Liquidambar*, *Oil of Liquidambar*, *American Storax*, *Copalin Balsam*, and sometimes, but erroneously, *White Balsam of Peru*. It gradually becomes concrete and darker coloured. Its properties are similar to those of storax. That of commerce is mostly brought from Mexico and New Orleans.—*L. orientalis*, a smaller tree with palmate leaves, is a native of the Levant and of more eastern regions, and yields abundantly a balsamic fluid, which has been supposed to be the *Liquid Storax* imported from the Levant; but on this point there is a diversity of opinion.

Liquidation, the winding-up of any business, but applied more particularly to joint-stock companies. The liquidation of insolvent firms is treated under BANKRUPTCY; that of registered companies is regulated by the Companies Acts, which provide three modes of liquidation: (1) by the court, (2) voluntary, and (3) subject to the court's supervision. Compulsory liquidation may be ordered on petition by a creditor or contributory; voluntary liquidation may be resolved upon by an extraordinary or a special resolution of the shareholders; and a supervision order may on petition and cause shown be pronounced in a voluntary liquidation.

In any case the liquidation is conducted by a *liquidator*, who in court liquidations is appointed by the court and called 'official liquidator,' but in voluntary liquidation is chosen by the shareholders. The liquidator's duty is to wind up as speedily as possible, but he may carry on the business temporarily should that appear necessary for a favourable realisation. He must also prepare a list of contributories, if the capital is not fully paid up or the company is unlimited. This list, which is made up from the register of shareholders, consists of members in their own right and those liable as representatives of others. In addition to these, there is a list (B) of those who have been members within a year of the winding-up and who are liable, if the existing members are unable to satisfy the necessary contribution. They can only, however, be called upon to contribute in respect of unpaid debts incurred before they ceased to be members. A contributory cannot set off a debt due to him by the company against calls by the liquidator so long as any creditors remain unpaid. The claims are ranked and adjudicated upon very much as in bankruptcy, and the surplus, if any, is divided among the shareholders. Unregistered companies, except railway companies incorporated by act of parliament, may be wound up under the provisions of the Companies Acts.

Liquids. See articles on Boiling, Capillarity, Cohesion, Diffusion, Evaporation, Heat, Hydrodynamics, Hydrostatics, Matter, Melting point, Osmosis, Solution, Spheroidal Condition, Surface-tension, and Viscosity.

Liquorice (*Glycyrrhiza*), a genus of perennial herbaceous plants of the natural order Leguminosæ, sub-order Papilionaceæ, having long, pinnate, sweet roots, and generally creeping root-stocks; pinnate leaves of many leaflets, and terminating in an odd one; flowers in spikes, racemes, or heads; a 5-cleft, 2-lipped calyx, and a 2-leaved keel. The ancient Greek name, now the botanical name, signifies *sweet root*, and from it, by corruption, liquorice and other modern names are derived. The roots of liquorice depend for their valuable properties on a substance called *Glycyrrhizine*, allied to sugar, yellow, transparent, uncrystallisable, soluble in both water and alcohol, and forming compounds both with acids and with bases.

They are a well-known article of materia medica, and were used by the ancients as in modern times, being emollient, demulcent, very useful in catarrh and irritations of the mucous membrane.—The roots of the Common Liquorice (*G. glabra*) are chiefly in use in Europe.

The plant has stems 3 to 4 feet high, and racemes of whitish violet-coloured flowers. It is a native of the south of Europe and of many parts of Asia, as far as



Liquorice (*Glycyrrhiza glabra*):
a, 1000.

China. It is cultivated in many countries of Europe, chiefly in Spain, and to some extent at Mitcham in Surrey and at Pontefract in Yorkshire. The roots are extensively employed by porters and brewers. They are not imported into Britain in considerable quantity, but the black inspissated extract of them (*Black Sugar* or *Stalk Liquorice*) is largely imported from the south of Europe, in rolls or *stocks*, packed in bay-leaves, or in boxes of about 2 cwt., into which it has been run. Liquorice is sometimes used in the manufacture of sweet tobacco. Liquorice is propagated by slips; and after a plantation has been made almost three years must elapse before the roots can be dugged up for use. The whole roots are then taken up. Liquorice requires a deep, rich, loose soil, well trenched and manured; the roots penetrating to the depth of more than a yard, and straight taproots being most esteemed. The old stems are cleared off at the end of each season, and the root-stocks so cut away as to prevent overgrowth above ground next year. The plant is propagated by cuttings of the root-stocks. The roots of the Prickly Liquorice (*G. echinata*) are used in the same way, chiefly in Italy and Sicily, Russia, and the East. The only American species is *G. lepalota*, which grows in the plains of the Missouri.

Liquor Laws. Restrictive legislation with regard to the sale of intoxicating drink is almost confined to the English-speaking peoples, and has been carried further in some of the British colonies and in portions of the United States than it has gone as yet in the United Kingdom. Sunday closing, for example, which is partial in the mother-country, is very general in the daughter-lands, and the principle of local option with regard to liquor licensing is widely spread in the colonies, while

total prohibition exists in the state of Kansas and in some other American communities.

In those of the United States in which there is not a local majority in favour of prohibitive legislation, the High License system is being gradually adopted, with the effect of destroying disreputable saloons.

The Dominion of Canada has a local option law, under which the localities have power by a bare majority of votes to close without compensation all places for the sale of drink. The act provides for a reversal of the operation upon a change of local opinion, and while the act has been largely put in force it has been subsequently suspended in many districts. In addition to this law, which is known as the Scott Act (1878), and applies to the whole Dominion, there are restrictive laws in several of the provinces. In some, as in Ontario, the maximum number of licenses that can be granted is regulated according to population, and sale of drink is forbidden on Saturday evenings as well as on Sundays. Generally speaking, it may be said that in all the provinces of the Dominion, except Quebec and British Columbia, there is a good deal of restriction, and in the North-west Territories there is total prohibition of the sale of alcoholic drink—a prohibition which, however, was originally imposed by the Dominion government for the purpose of preventing sale of drink to Indians, but which has been continued in spite of the present existence of a very large white majority. Throughout the greater part of Canada two provisions prevail, which exist also in many states of the American Union and in some of the Australasian colonies. The one is that known as the Civil Damages clause, which provides that wherever any person comes to his death by suicide or otherwise during intoxication the seller of the liquor that caused the intoxication is liable to an action for damages. The other is a provision that the relatives of intemperate persons may notify sellers of drink not to sell it to such persons, and that magistrates may put such persons under notice as habitual drunkards, to whom also drink cannot be sold. This last law, with regard to putting persons under special prohibition, is being gradually adopted in all new liquor acts passed by British colonies and by American states, but there are considerable variations in the mode of application. In some cases the law is so severe that both the publican and the habitual drunkard are subject to punishment if the drunkard is found in the neighbourhood of the licensed house. In certain colonies and provinces, in addition to relatives and magistrates, ministers of religion may put the law in force; and there is a general tendency to strengthen clauses sharply restricting the liberty allowed in the United Kingdom for the consumption of drink by persons who are given to the immoderate use of liquor, and who, owing to such use, waste their property, endanger their health, and diminish the comfort of those about them.

Turning to the Australasian colonies, Victoria possesses, along among English-speaking countries, the principle of local option accompanied by compensation. New Zealand and Queensland possessed in 1890, when South Australia and Tasmania were entering upon, legislation more similar to that of Canada. The New Zealand act creates elective licensing committees, but no new licenses can be granted until the ratepayers have determined on a poll, by a bare majority, that the number of licenses may be increased. In Queensland two thirds of the ratepayers in any locality have power to close all houses, and a bare majority power to reduce the number of licenses or to put a stop to the issue of fresh licenses. In New South Wales there exists a mild form of local option as to new licenses or the increase of licenses, which, however, can scarcely

be said to exceed an expression of local opinion for consideration by the licensing magistrates.

The South African colonies have stringent legislation, not very well enforced in practice, against the sale of drink to the aborigines, but interfere less than does the Dominion of Canada or than do the Australasian colonies with the drinking habits of the white population.

In the crown colonies there is an extraordinary variety of legislation upon the licensing of houses for the sale of intoxicating liquors. In many there is Sunday closing, some imitate the self-governing colonies in forbidding the sale of drink to minors, but few of them possess any form of local option, although that system exists in some, as, for example, the Bahamas.

Throughout Canada and Australia, as in the United States, there is a large party in favour of total prohibition; and the example of the state of Kansas is pointed to as showing the advantages of the system. On the other hand, in Canada, Australia, and some of the United States there is much evasion of the present laws; and this evasion has been in the Dominion one of the chief causes which have led to the abandonment of the prohibitive provisions of the Scott Act in districts where it had previously been put in force. Generally speaking, however, it must be noted that the tendency of legislation and of opinion in the English speaking countries is towards an extension of the principles either of local option or of prohibition.

Much attention has been called in parliament to the liquor question in India and Ceylon, and it has been asserted (and the House of Commons, to judge by a vote in which the government was defeated in 1889, seems to have credited the assertion) that the Indian government has tried to stimulate the sale of drink among natives with a view to the improvement of the revenue; while a similar attack has been made upon the colonial government of Ceylon. The Indian government stoutly denies the charge, and maintains not only that it has had no such intention, but that the measures which have been taken of recent years are rather calculated to decrease than to stimulate the sale of drink. On the other hand, there can be little doubt that the sale of drink in India has increased, the government maintaining, however, that this has been only a consequence of a change in the habits of the people and of the increase in the rate of wages. All organs of native opinion appear, nevertheless, to support the view taken by the majority of the House of Commons. Some official writers, and others friendly to the government of India, have argued that there has in fact been no increase in the consumption in India of intoxicating liquors, and that the increase shown by statistics is only the result of the suppression of illicit distillation. It is, however, obvious that, in face of the strong opinion which exists upon the subject in India and in the House of Commons, government will have to take steps to check that consumption of strong drink which is obnoxious to the religious views of most of the Indian people. See LICENSING LAWS, GOTTENBURG, TEMPERANCE.

Lira (Lat. *libra*). See FRANC.

Liria, a town of Spain, stands on a fertile plain 14 miles NW. of Valencia. Pop. 9445.

Liriodendron. See TULIP-TREE.

Lisbon (Port. *Lisboa*), capital of Portugal, stands on the northern shore of the Tagus (*Tago*), at the shoulder of its bottle-shaped bay—an expansion of the river and 9 miles from the river's mouth; it is 412 miles by rail WSW. of Madrid. The city extends for some 7 miles along the shore, and climbs up the slopes of a low range of hills, occupying a site which for imposing beauty is

surpassed by only two other cities in Europe—Constantinople and Naples. The oldest part of Lisbon is that which escaped the earthquake of 1755; it lies on the east, round the citadel, and consists of narrow, intricate streets, not over clean. It is still known by its Moorish name of Alfama. The western portions were built after the earthquake, with wide and regular streets, fine squares, and good houses. The summits are mostly crowned with what were formerly large monasteries, now dissolved. The cathedral of the 'patriarch,' built in 1147, restored after 1755, has a Gothic façade and choir; its interior is gloomy. The large church of St Vincent contains the tombs of the royal (Braganza) family. The church of Estrella has a dome of white marble, and is a reduced copy of St Peter's at Rome. In San Roque is a chapel thickly encrusted with mosaics and costly marbles; it was first erected in Rome, and consecrated by the pope saying mass in it, before it was set up in Lisbon. But the finest structure in the city is the monastery and church of Belem, a monument to the great seamen of Portugal; it was begun in 1500 on the spot from which Vasco da Gama embarked (1497) on his momentous voyage. It is constructed for the most part in the Gothic style, with an abundance—a superabundance—of decorative ornament, and has magnificent cloisters. Inside the church are new tombs (1880) to Camoens and Vasco da Gama, and the grave of Catharine, wife of Charles II. of England. The monastery is now used as an orphanage and foundling hospital. Neither of the royal palaces, that of the Necessities, or that of Ajuda at Belem, possesses features of great interest. A line square facing the bay is surrounded with government offices, the handsome custom-house, and the marine arsenal. The arts and sciences are not in a flourishing condition, notwithstanding the existence of an academy of sciences (1779), with a library of 60,000 vols., an academy of arts, a polytechnic school (chiefly for the technical branches of the army), a medical school, a conservatory of music, a public library of 200,000 vols. and 9500 MSS., natural history and other museums, two observatories, &c. There are also a military arsenal, a mint, a large lazaretto, a military and a naval school, &c. A magnificent aqueduct, completed in 1738, brings water to the city from springs 14 miles to the north-west. It withstood the shock of the great earthquake, although it crosses a valley 263 feet above its lowest point, and on thirty-five arches, the longest 110 feet. In the cemetery of the English church Fielding was buried in 1754. The population of the city was 246,343 in 1878; but the municipal boundaries were enlarged in 1885 so as to include Belem and other suburbs, and in 1891 the population was 308,700. The figures quoted include 35,000 Gallegos or natives of Galicia, who serve as water-carriers, porters, &c. A series of forts protect the seaward approaches to the city. The harbour is one of the finest in the world, deep, well sheltered, and large enough to hold all the navies of Europe. Nevertheless, in 1899-1900, the government were spending £2,400,000 in improving the port, which is entered annually by 2500 to 3000 vessels of about 2,000,000 tons burden (of which 50 per cent. is British), importing principally corn, cotton goods, sugar, fish, coal, timber, tobacco, coffee, and petroleum to a value of between £5,000,000 and £6,000,000 a year. The exports, whose annual value may be £4,000,000, embrace wine, cork, fish, cattle, oil, salt, and fruits. Much of the total trade is from and with the Portuguese colonies, such imports as cocoa, coffee, and india rubber coming thence. But the trade of Lisbon is small compared with what it was in Portugal's palmy days. The share

of the Portuguese in this trade is exceeded not only by the share of Great Britain, but by that of France and that of Germany. The most important industries of the city are in gold and silver wares and in jewellery; next come cotton-spinning and weaving, the manufacture of silk, hamp, chemicals, hats, boots, tobacco, soap, cutlery, and stoneware, and iron founding.

Lisbon is a contraction of Olisipo, the name by which the place was known when it was the capital of the Lusitanians; it was also sometimes called Ulyssippo, to connect it with a myth about Ulysses. From the Romans it passed to the Goths, and from them was wrested by the Moors in 716. They called it El-Oshbama, and kept their hold of it down to 1147, when Alphonso I. of Portugal seized it with the help of English, German, and Flemish crusaders. In 1373 the city was captured and in great part burned by the Castilians, who again laid siege to it eleven years later, but without success. It was made the capital of the kingdom by John I. in 1422. In 1580 it was seized by Alva for Philip II. of Spain; and it was from this port that the 'invincible' Armada set sail. When the Duke of Braganza roused his countrymen to shake off the Spanish yoke (1640), he recaptured Lisbon, and once more it was made the capital. But the city was doomed to misfortune; it had been three times taken from the Moors by the Christians previous to 1147, it had suffered from a severe earthquake in 1344, and had been visited by the plague in 1348; but the greatest disaster overtook it on 1st November 1755, when, in less than ten minutes, the greater part of the city was made a heap of ruins, from 30,000 to 40,000 persons were killed, and damage done to the extent of nearly 20 millions sterling—one of the greatest earthquake convulsions on record, the shock being perceptible in one direction as far as Scotland, in another at Mitylene in Asia Minor, and in a third at Fez in Morocco. The French were in possession of the city for ten months during 1807-8. The tale of Lisbon's misfortunes was completed by a series of military revolts during the second quarter of the 19th century, especially in 1831, and by a bad attack of yellow fever in 1859. St Antony of Padua, Camoens, and Pope John XXI, were natives of Lisbon. See Macedo, *Guide to Lisbon* (1875).

Lisburn, a market-town, partly in Antrim, partly in Down, on the Lagan, 93 miles by rail N. by E. of Dublin and 8 SW. of Belfast. The importance of the place is due to the Conway family, who built a castle here in the time of Charles I. and introduced the existing industries. It is a clean and well-ordered town, and manufactures linens, damasks, muslins, &c., and has flax-spinning and bleaching. Its parish church is the cathedral of Down, Connor, and Dromore, and contains a monument to Bishop Jeremy Taylor, who died here in 1667. Till 1885 Lisburn returned one member to parliament. Pop. (1851) 6569; (1881) 10,755; (1891) 12,250.

Lisieux (ancient *Nortiomagus Leuciorum*), a town in the French department of Calvados, 30 miles by rail E. by S. of Caen. In the church of St Pierre (1045-1233; a cathedral down to 1801), Henry II. of England married (1152) Eleanor of Guienne. Lisieux is the centre of an extensive manufacture of coarse linens (*cratons*, from the original maker), woollens, flannels, cottons, &c. Pop. (1872) 12,520; (1891) 16,260. Four miles distant is Val Richer, where stood the abbey of which Thomas Becket was first abbot, and the ruins of which were made into a summer residence for Guizot.

Liskeard, a municipal borough in Cornwall, stands on steep hills overlooking the Looe, 18 miles

WNW. of Plymouth. It has manufactures of leather and iron, and a lively trade with the neighbouring mines. St Martin's church, Perpendicular in style, and restored in 1879, is one of the largest in Cornwall, and has a tower of the 14th century. The town-hall (1859) is a good Italian building. A stannary or coinage town, Liskeard was made a free borough in 1250 by Richard, king of the Romans, who built a castle here. Till 1832 it returned two members (Coke and Gibbon the most illustrious), and then till 1885 one member. Pop. (1851) 4386; (1881) 4536; (1891) 3984. Two miles south is the spring of St Keyne (q.v.). See Allen's *History of Liskeard* (1856).

Lisle, ALICIA, the aged widow of one of Cromwell's lords, was beheaded at Winchester on 2d September 1685 for having sheltered one Nelthrop, a rebel fugitive from Sedgemoor. Thirty-six years before, at Charles I.'s execution, she had said that her blood leaped within her to see the tyrant fall.

Lisle. See ROUGET DE LISLE.

Lismore, a town on the Blackwater, in Ireland, in the two counties of Cork and Waterford, and 43 miles SW. of Waterford city. The cathedral, the parish church since the see was united to Cashel, was rebuilt in 1663, on the site of a monastery founded before 549, and a celebrated school of learning from 635 till its destruction by the Danes in 833. The castle, originally founded by John Lackland in 1185, was the residence of the bishops till the 16th century. In 1587 it was given to Sir W. Raleigh, who sold it to the 'great' Earl of Cork, and in it his son, Robert Boyle (q.v.), was born. It was twice besieged during the Great Rebellion, and on the second occasion (1645) it yielded to the parliamentary forces. In 1753 it passed to the Duke of Devonshire. Lismore returned two members from Charles I.'s reign to the Union. Pop. 1660.

Lismore (Gael. 'great garden'), an island of Lorn, Argyllshire, in Loch Linnhe, 1 furlong from the mainland, and 8 miles N. of Oban. It rises to 417 feet, and is 10½ miles long, 1½ mile broad, and 604 acres in area. Besides a lighthouse (1833), it contains several interesting remains—the choir of the cathedral (1236) of the pre-Reformation diocese of Lismore or Argyll (since 1749 used as the parish church); Achanduin Castle, the residence of the bishops; and Castle-Rachal, a Scandinavian fort. Pop. (1831) 1790; (1891) 561, mostly Gaelic speaking. See also GAELIC LANGUAGE.

Lissa (Pol. *Leszno*), a town of Prussia, 40 miles S. by W. of Posen, was during the 16th and 17th centuries the headquarters of the Bohemian Brethren in Poland; here were their most celebrated school, a seminary, a printing-office, and their archives. The town grew up round a colony of that sect, to whom the Leszczynski family afforded an asylum early in the 16th century. It was burned by the Poles in 1656, and again by the Russians in 1707; but is now a place of (1890) 13,116 inhabitants.

Lissa, an island of Dalmatia, in the Adriatic Sea, 32 miles SW. of Spalato. It has an area of 40 sq. m., is mountainous, grows good wine and olive-oil, and has 7871 inhabitants—4317 at the capital, Lissa. The island was held by Great Britain from 1810 to 1815. Off it the Italian fleet was defeated by the Austrians under Tegetthoff on 20th July 1866. See TACTICS (NAVAL).

Lissajous' Figures. See SOUND.

Lister, JOSEPH, LORD (cre. 1897), P.R.S. (from 1895), knight of the Prussian order *Pour le Mérite* and of other foreign orders, was born at Upton, Essex, 5th April 1827, the son of the microscopist Joseph J. Lister, F.R.S. (1786-1869). He graduated at London University in arts (1847)

and medicine (1852), and became a Fellow of the Royal College of Surgeons, England, in 1852, and of the Royal College of Surgeons, Edinburgh, in 1855. He was successively assistant-surgeon and lecturer on surgery, Edinburgh; regius professor of Surgery, Glasgow; professor of Clinical Surgery, Edinburgh; professor of Clinical Surgery, King's College Hospital, London (1877); and was made surgeon extra-ordinary to the Queen. In addition to important observations on the coagulation of the blood, the early stages of inflammation, and other matters, his great work has been the introduction of what is known as the Antiseptic (q.v.) system of surgery. This system and the theory upon which it is based are now almost universally accepted; and their acceptance has in great measure revolutionised modern surgery, removing some of its most serious dangers, and thus greatly widening its field of usefulness. Lister has been awarded many foreign honours, and received the medal of the Royal Society in 1880, the prize of the Academy of Paris in 1881. He is LL.D. of Edinburgh, Glasgow, and Cambridge, and D.C.L. of Oxford; and has written various papers and lectures. He was made a baronet in 1883.

Liston, JOHN (1776-1846), low comedian, played from 1805 to 1837 at the Haymarket, Drury Lane, and the Olympic. 'Paul Pry' (1825) was his most popular creation. See H. B. Baker, *Our Old Actors* (new ed. 1881).

Liston, ROBERT, a celebrated surgeon, was born at Ecclesmachan manse, near Linlithgow, in 1794. He studied at Edinburgh and London, and settled in Edinburgh in 1818 as lecturer on surgery and anatomy. His surgical skill, and the rapidity with which his operations were performed, soon acquired for him a European reputation; and in 1835 he accepted the invitation of the council of University College, London, to fill the chair of Clinical Surgery. He soon acquired a large London practice; in 1840 he was elected a member of the council of the College of Surgeons; and in 1846 he became one of the Board of Examiners. In the very climax of his fame, he died 7th December 1847. His most important works are *Elements of Surgery* (1831) and *Practical Surgery* (1837). His uncontrollable temper and strong language involved him in various quarrels with his professional brethren, yet he always succeeded in obtaining the regard and esteem of his pupils.

Liszt, FRANZ, pianist and composer, was born at Raiding, in a German-speaking district of Hungary, on October 22, 1811. His father, Adam Liszt, steward of Prince Esterhazy's estates, had himself musical gifts, and guided the precocious talents of his son with great judgment. At the age of nine Franz played in public at Odenburg, and afterwards at Presburg, when several Hungarian noblemen offered the means for his education, and he was taken to Vienna, where he studied under Czerny and Salieri. On December 1, 1822, he appeared at a concert there, and the audience were in raptures with his playing; April 13, 1823, was the date of a memorable concert, after which Beethoven ascended the platform and kissed the boy—a reminiscence to which he always alluded with veneration. He proceeded to Paris, and, though admittance to the Conservatoire was denied by the inflexible Cherubini, he continued his studies under Paer and Reicha. He soon became a favourite in Paris salons, and made a tour to Vienna, Munich, Stuttgart, and Strasburg, with unmistakable success. He visited England thrice in 1824-27, but met with scarcely so much appreciation. In 1827 his father died, and he entered on a great mental struggle. He was repelled by the

then low estate of musical art and artists, and his strong religious feelings drew him towards the church. He was also fascinated by Saint Simonianism, and at intervals the attractions of the world influenced him strongly. In 1831 he heard Paganini, and was fired by the resolve, which he carried to triumphant issue, to become the Paganini of the pianoforte. He became intimate with most of the great *littérateurs* then in Paris, more especially with Lamennais, Lamartine, Victor Hugo, and George Sand, who exercised a marked influence upon him, as did also Chopin. From 1835 to 1845 dates his relationship with the Comtesse d'Agoult (q.v.), known in literature as Daniel Stern, who bore him three children, one of whom, Cosima, became the wife of Von Bülow, and subsequently of Richard Wagner. The enthusiasm which his playing excited in Paris, as elsewhere, has been graphically depicted by Heine. In 1849, at the height of popularity, he retired to Weimar to direct the opera and concerts, and to devote his time largely to composition and teaching. Here he brought out remarkable works denied a hearing elsewhere—e.g. Wagner's *Lohengrin* and Berlioz's *Bevernato Cellini*; and the little town became the centre of musical life in Germany. Here, too, commenced the close relationship with, and incalculable services rendered to, Wagner. In 1861 he resigned his appointment, and his life was subsequently divided mainly between Weimar, Rome, and Budapest, in which latter city he was in 1870 appointed president of the Academy of Music. In 1865 he received minor orders in the Church of Rome, and was afterwards known as Abbé. The record of his visit to London in 1886 is that of a triumphal progress. His influence was irresistible. Passing through Paris, he travelled to Baireuth, where, after attending several of the festival performances, he was attacked by hopeless illness, and breathed his last on July 31, 1886.

All things considered, he may be regarded as at the time the foremost figure in the musical world. As a pianist he was simply unapproachable; he exercised a charm bordering on the fabulous. His supreme command of technique was forgotten by hearers in admiration of the poetic qualities of his playing. That he was equally unique as a teacher is amply evident from the enthusiastic veneration of his pupils, among whom are many of the greatest living masters of the pianoforte. His literary works on music, though rather rhapsodical, are of real value; they include monographs on Chopin and Franz, and a volume on the music of the Gypsies. His influence in bringing to a hearing some of the greatest works of other musicians was invaluable. As a composer there is some difficulty as yet in properly estimating his work. His transcriptions for the piano, at least the later ones, are universally considered the finest ever made; his Hungarian rhapsodies may be deemed the highest reach of this form of composition. His pianoforte works are of enormous number, and not yet completely known. All his original works have a very distinct, sometimes a very strange individuality. He has the merit of creating, in his twelve symphonic poems, a new form of orchestral music. Their most distinctive features are the carrying out of a definite 'programme,' and the Wagnerian use of the *leit-motif*, by which unity is given to the whole piece. One or two masses, the 'Legend of St Elizabeth,' and a few other works, embody his religious aspirations, with reverence for old forms. His songs have a peculiar charm. As a man he possessed a most striking personality, and exercised a powerful fascination on all who came in contact with him. To call his generosity merely is to do honour to the title. The whole proceeds

of every one of his concerts subsequent to 1847, which must have amounted to an enormous sum, were devoted to the benefit of others.

See his *Letters* (trans. 1894); the *Lives* by Miss Bammann (2 vols. Leip. 1880-93, trans. 1882), Nohl (trans. Chicago, 1884), Martin (1886), De Beaufort (1886), and A. Gollerich (Leip. 1888); the *Recollections* (1888) of Miss Janka Wohl; and the *Correspondence, 1841-61, between Wagner and Liszt* (Eng. trans. by F. Huefner, 2 vols. 1888).

Litany (Gr. *litania*, 'supplication'), a form of prayer in which the same thing is repeated several times at no long intervals. Hence in Latin the word is always used in the plural, *litanæ*. The common formula, *Kyrie eleison, Christe eleison, Kyrie eleison*—Lord, have mercy upon us—Christ, have mercy upon us—Lord, have mercy upon us—is the simplest ('lesser') litany. The word may be properly applied to the forms common among the Eastern Christians at different points during the celebration of the eucharist (see LITURGY) and other services, in which the deacon recites a number of short supplications, and the people reply after each '*Kyrie eleison*.' This practice formerly existed in the West at the commencement of the liturgy: it is still preserved in the Ambrosian rite during Lent; and the ninefold *Kyrie* of the Roman rite is merely a surviving remnant of the same thing, the responses having been preserved, although the prayers have been dropped. Owing to the litany being a form of public prayer specially adapted for and used in public processions, the word *litania* has now obtained among the Greeks the secondary and technical meaning of a *procession*, and the word regularly applied by them to the forms of united prayer conducted by the deacon is *ektonê*.

In the Latin churches the word litany is now used to indicate a special service or form of supplication of medieval origin, in which, after the simple *Kyrie* and the invocation of Christ and of the Holy Trinity, follows a very long string of saints' names, each followed by the response 'Pray for us;' then a series of clauses naming different evils, and a series of adjurations based on events in the life of Christ, both followed in every instance by the response 'Deliver us, O Lord;' and next a series of supplications, beginning 'That it may please Thee, to all of which the response is 'We beseech Thee, hear us.' After this comes the triple invocation of Christ as the Lamb of God, the simple *Kyrie* again, the Lord's Prayer, Psalm lxx., a series of pieces of an intercessory character, and a very large number of prayers or collects. It may be observed that in the medieval editions the names of local saints are generally found mingled with the others. According to the present Roman rule the use of the litany is only absolutely commanded upon the Monday, Tuesday, and Wednesday before Ascension Day, when a procession is made to implore a blessing upon the fruits of the earth, and which are thence called Rogation (or 'asking') Days, and upon St Mark's Day (April 25), when a procession is made to pray for public health during what is in the south an unhealthy part of the year. The litany is, however, ordered upon nearly every occasion of public supplication, such as war, famine, pestilence, &c., and is subject to great alterations, especially after the Lord's Prayer, to meet the special occasions. It is also used on all special occasions, such as ordinations, consecrations, &c., with special alterations, and, in an abridged form, before the Mass on the eves of Easter and Pentecost.

The form of the litany used by Anglicans is a translation of the pre-Reformation one, but extremely free. The invocations of saints and the psalm are entirely omitted. Its use is prescribed

upon all Sundays, Wednesdays, and Fridays, when it is used either as a special service or appended to morning prayer. It is also used at ordinations. It does not possess the same elasticity as the Roman for adaptation to different occasions.

It may be worth adding that in the Latin churches there are also two other litanies, the use of which is permitted in public worship, but which do not form any part of the church service. Both begin like the litany proper. The first is called that of the Holy Name (or sometimes 'of Jesus'). In this the invocation of the Trinity is immediately succeeded by a long series of invocations of Christ under different titles (such as 'Jesus, Good Shepherd,' 'Jesus, King of all the Saints'), with the constant response 'Have mercy upon us.' The other litany is called that of the Blessed Virgin (or sometimes 'of Loretto'). In it the invocation of the Trinity is succeeded by a series of titles addressed to the Blessed Virgin.

There are also a vast variety of other so-called litanies, mostly of French origin, and generally designed to invoke some particular saint under a string of complimentary epithets, on the model of the litany of the Blessed Virgin. Their public use is prohibited, and there is no more guarantee of their doctrinal soundness than may attach to the approval of any bishop given to the book of prayers for personal use in which they may happen to be found.

Litchi, or LEE-CHEE (*Nephelium Litchi*), one of the most delicious fruits of China, Cochin-China, and the Malay Archipelago. The tree which produces it belongs to the natural order Sapindaceæ, and has pinnate leaves. The fruit is of the size of a small walnut, and grows in racemes. It is a red or green berry, with a thin, tough, leathery, scaly rind, and a colourless, semi-transparent pulp, in the centre of which is one large dark-brown seed. The pulp is slightly sweet, subæcid, and very grateful. The Chinese preserve the fruit by drying, and in the dried state it is imported into Britain.

Literary Fund. ROYAL, was founded in 1790 by David Williams, an ex-dissenting minister, the friend of Franklin, Mackintosh, &c., and was incorporated in 1818, its object being to relieve literary men of all nations. In 1889 grants to the amount of £2095 were made to forty authors. From 1790 till 1889 a sum of £109,000 has been thus distributed. The expenditure is met by the subscriptions at the anniversary dinner, and investments: the income was £3850 in 1889.

Litharge. See LEAD.

Lithgow, WILLIAM, Scottish traveller, was born at Lanark in 1582. He had already visited the Shetlands, Bohemia, Switzerland, &c., when, in 1610, he set out from Paris, by way of Italy and Greece, to Palestine and Egypt, performing most of this and his subsequent journeys on foot. His second tramp led him through North Africa from Tunis to Fez and back, and home by way of Hungary and Poland. In his third and last journey (1619-21) to Spain *via* Ireland, he was seized as a spy at Malaga, tortured both by his jailers and by inquisitors, and only released through the agency of the English consul. After he returned to London he became an object of commiseration to the king and his court. Gondomar, the Spanish ambassador, promised him reparation, but contented himself with promising. So Lithgow assaulted, or by another account was assaulted by, him in the king's ante-room, for which he was clapt into the Marshalsea. He died at Lanark, perhaps in 1645. His enthusiastic but most interesting *Rare Adventures and Painful Persecutions* was published in a complete form in 1632 (2th ed. 1814), though an incomplete version came out in 1614. Besides this he wrote accounts of *The Siege of Breda* (1637) and

the *Siege of Newcastle* (1645; new ed. 1820), *Poems* (ed. by James Maidment, 1863), and other works.

Lithic Acid. See URIC ACID.—*Lithic Acid Diathesis* is the term employed in medicine to designate the condition in which there is an excess of lithic (or uric) acid, either free or in combination, or both, in the Urine (q.v.).

Lithium (sym. Li; equiv. 7.0; sp. gr. 0.5936) is the metallic base of the alkali *lithia*, and derives its name from the Greek word *lithos*, 'a stone.' It was discovered by Arfvedson in 1817 in some Swedish minerals; but since the introduction of spectroscopic research it has been found to be widely present in many mineral waters, in the ash of plants, &c. The metal is of a white, silvery appearance, and is much harder than sodium or potassium, but softer than lead. It admits of being welded at ordinary temperatures, and of being drawn out into wire, which, however, is inferior in tenacity to leaden wire. It fuses at 356° (180° C.). It is the lightest of all known solids, its specific gravity being little more than half that of water; it decomposes water at ordinary temperatures. It burns with a brilliant light in oxygen, chlorine, and the vapours of iodine and bromine. It is easily reduced from its chloride by means of a galvanic battery. When lithium is burned in air it forms an oxide, lithia, Li₂O, along with a trace of a higher oxide. This oxide, when treated with water, yields a hydrate, LiOH, having alkaline properties and resembling soda and potash. Lithia forms a series of salts (carbonate, chloride, citrate, &c.) analogous to the potash and soda salts, and all of these, when placed in the flame of a Bunsen burner and examined with the spectroscope, show characteristic red bands by which their presence can always be ascertained.

In medicine the salts of lithia hold a high place as solvents of uric acid. The carbonate and citrate are used for this purpose, and are said to be much more efficient in cases of gout and gravel than the potash salts.

Lithography (Gr. *lithos*, 'a stone,' and *graphein*, 'to write'), the art of printing from stone, and one of the most important of the reproductive arts, was invented in 1796 by Aloys Senefelder (1771-1834). In that year a piece of music—Senefelder's first work—was printed from the stone, and in 1800 he patented his invention in Bavaria, most of the German states, and Austria. Afterwards he opened establishments in London and Paris, but did not succeed very well. The great secrecy and jealousy with which the new art was guarded by its patentees prevented progress being made, and it was not till many years afterwards that their complicated manipulation became sufficiently simplified for the rapid advance which then became possible. Senefelder, on whom the king of Bavaria settled a pension, lived to see his invention brought to complete perfection.

The principles on which lithography is founded are (1) the strong adhesion of greasy substances to calcareous stone; (2) the affinity of one greasy body for another, and their antipathy to water; (3) the facility with which calcareous stone imbibes water. It follows that, if a greasy line be drawn on a prepared stone, its adhesion is such that it can only be erased by entirely removing the surface of the stone so far as the grease has penetrated. If water be put on the surface of the stone it remains on those parts not covered with grease; a roller charged with greasy ink may then be passed over the stone, the ink adhering to the greased portions, while the parts wet with water will repel the ink and remain clean. A piece of paper put on the stone, if pressure be applied, will receive an impression in ink of the greasy line. The covering

of the stone with a solution of gum-arabic (to be afterwards described) is an almost indispensable aid to the water in resisting the ink.

There are various methods employed in lithography: drawing on stone with pen or brush with liquid ink; drawing on paper, and transferring to stone; engraving on stone; drawing on stone with crayons or solid ink, transferring from engraved plates or woodcuts, &c. These differ only in the manner of applying the greased drawings to the surface of the stone. The printing from them is in nearly all cases identical.

The Stones.—The immense quarries of Solenhofen in Bavaria furnish the best stones; others of inferior quality are obtained in France and Italy. The stones are composed of lime, clay, and siliceous earth, and are of various hues, from a pale yellowish-white to a light buff, reddish, pearl-gray, blue, and greenish colour. Those of a uniform gray colour are the best. They are found in beds, commencing with layers of the thickness of paper; the thickness required for printing-stones being from about 2 to 4 or 5 inches. When in the quarry they are soft and easily cut to any required size. They are afterwards ground face to face with sand and water, and when quite level polished with pumice-stone, and finally with smooth polishing stone. Sheets of zinc faced with thin coatings of artificial stone have been introduced, but not as yet with much success.

The writing and drawing inks and crayons are composed of lard, hard soap, white wax, shell-lac, Venetian turpentine, carbonate of soda, and Paris black. The proportions used and the methods of manufacture vary considerably. All descriptions can be purchased ready prepared. The greasy ingredients are the important parts; the black is only added to enable the artist to see the effect he is producing as he goes on.

Writing or drawing on stone is performed with a fine pen or brush, or a ruling pen for straight lines. The ink is rubbed down with a little water and under gentle heat, in the same manner as China ink, and the subject may be traced as for a drawing on paper. Great care is necessary in handling the stone, as its affinity for grease is so keen that a finger-mark would develop into a black blot in printing. When the drawing is finished it is covered over with a solution of gum-arabic in water. This gumming fills up the pores of the stone on the undrawn parts, and prevents the greasy lines of the drawing from spreading. The stone is then removed to the printing-press and prepared for printing. The gum is first washed off with clean water, enough remaining in the pores of the stone, however, to assist the water to resist the ink in the subsequent printing. The stone is then damped with a canvas cloth, and a roller (made of wood or iron, covered with one or two thicknesses of flannel and an outer covering of fine leather) charged with printing-ink is passed over the stone till every part of the drawing is thoroughly inked. Any accidental grease or finger-marks will now become visible, and must be removed with acid, scraping with a knife, or polishing with polishing stone. When the drawing is made satisfactory the stone is washed over with a weak solution of nitric acid in gum-water. This *etching*, as it is called, is a very important operation. If applied too strong the acid would remove the drawing completely from the stone; but when diluted to the proper strength it gently eats away the surface of the bare parts of the stone, opening up the pores for the better reception of the gum to be afterwards applied, thoroughly cleans it from grease soils, and sharpens the lines of the drawing. When the stone is sufficiently etched the acid is washed off and another coating of gum applied; when this is

dry it is again washed off, and, usually, to clean the stone from the drawing-ink, the surface is washed with turpentine. For all that can be now seen on the stone the work is quite lost; but it is only the black ink that is washed off; the *grease* lines are *in* the stone, which is all that is necessary. The stone is now damped with a cloth and inked with a roller till all the drawing is black again; a piece of paper is placed on the top, passed through the press, and when taken off has received an impression of the drawing. The damping and inking is repeated for every impression, and when the stone is put away or left for a time it is, for preservation, covered with the indispensable gum, which is again washed off when printing is resumed. The ink for black printing is composed of Paris black, ground up with varnish made from boiled linseed-oil.

Writings and drawings made on prepared paper and transferred to stone for printing are, perhaps, the most important items in general lithographic work. The transfer paper is prepared on one side with a coating of isinglass, flake-white, and gamboge, and afterwards smoothed by passing several times through a press over a heated stone. The writing or drawing is made on this preparation with a pen or fine brush with the lithographic transfer ink, and when finished is transferred to the stone in the following manner. The paper is put for a few minutes between damped blotting-paper. A *warmed* polished stone is put in the press, the paper is placed with the coated side upon it, and passed several times through the press, after which the paper is damped with water and gently rubbed with the fingers till it comes easily off, leaving the drawing adhering to the stone. The stone is gummed over and proceeded with as already described. After the first inking-up, and before etching, any defects in the transfer can be touched up with a pen or brush. In France and some other countries this class of work, however, is generally either directly drawn or engraved on the stone.

Fresh impressions of lithographs, of engravings on wood, steel, or copper, and of letterpress may be transferred to and printed from the stone by the above process, the paper used being prepared with a special composition, and the ink a mixture of the writing and printing inks. Many subjects, such as music titles, &c., are engraved cheaply on zinc, expressly to be transferred to stone. When the design is small and required in large numbers, it may be transferred many times on one stone, and many printed on one sheet of paper at every impression.

Engraving on stone, so called, is another method of putting a drawing on stone, and is as follows. A polished stone is covered with a coating of gum slightly coloured; this is afterwards roughly washed off, leaving only a very thin film of the gum, which can be easily cut through. On this ground the drawing is executed with etching-points of diamond and steel of various breadths, exactly as in etching, the surface of the stone being cut through the gum in making the lines. When the drawing is finished any greasy matter is rubbed into the lines and allowed to remain an hour or two till the stone has imbibed enough at the lines. The gum is then washed off, and the stone damped and inked and proceeded with as above, except that engraved stones are generally inked with a dauber, i.e. a piece of wood covered with one or two pieces of flannel, with which the ink is rubbed into the lines.

The following modification of this process is very useful when a photograph or drawing has to be copied in line on the stone. A thin sheet of gelatine is placed over the subject to be copied, and, it being transparent, a careful drawing may

be made on it with etching-points. When finished, lithographic ink is rubbed into the lines and the gelatine placed on the stone and the drawing transferred by passing through the press. The weak point of this process is that the gelatine is apt to warp on the stone and spoil the transfer; in which case the drawing is lost.

Chalk-drawings were, before the invention of the steam lithographic press, and still on rare occasions are, drawn on grained stones. The grain, coarse or fine as required, is imparted to the stone by grinding with sand of varying degrees of fineness. The drawing is made on the stone with lithographic crayons in the same manner as the ordinary drawing chalks on ordinary crayon-paper; when finished it is proceeded with as before. Very beautiful work can be produced in this way; but as, owing to various causes which are too technical for our space, the grained stone cannot be printed at the steam-machine, and hand-press printing is too expensive for modern requirements, such work is now almost invariably executed by the *grained-paper process*. A sheet of copper or other metal is grained on the surface by aquatint, stipple, or ruling-machine; paper, coated with a white transferring ground, is passed through a press on the face of the prepared plate, becomes impressed with the grain, and may be drawn on with lithographic chalks in the same way as a grained stone. This drawing is transferred to a *flat* or polished stone in the same manner as writing or pen drawing, and printed in any lithographic press. Very good work is produced by this process, but the result of the somewhat artificial grain of the copper-plate is inferior to the beautiful grain of the ground stone. In the United States drawings are made on grained stones and impressions transferred to flat stones for printing; but this process has not found much favour in Great Britain.

Photo-lithography is a very useful method of reproducing in any size, for stone printing, existing drawings, such as architects' plans, maps, &c. A photo-negative of the required size is taken from the drawing to be reproduced, and is exposed to light over a thin film of bichromatised gelatine on paper. The paper, after being soaked in water, which takes out the bichromate unaltered by the light, is stretched on a sheet of glass and carefully inked with a velvet roller. The ink only adheres to the parts rendered insoluble by the light, and which have remained dry during the soaking, and leaves the soluble parts, which are wet, quite clean. This is transferred to stone in the ordinary manner.

Chromo-lithography is the most beautiful of all the methods of printing from stone. The object being to produce, as nearly as possible, fac-similes of pictures in colour, it is necessary to employ a number of stones, in some cases as many as twenty or thirty, each printing a separate tint, to produce the infinite variety of colour in a finished colour-drawing. The usual method of procedure is as follows. A careful outline of the entire design is drawn on, or transferred to, a stone; from this, called the *key*, as many copies are printed as there are colour-stones required. These impressions are dusted with dry black or rubble, and, being set off on the colour-stones, form guides to the artist in drawing in the various colours; after which the key lines can be washed away with water. On one of these stones the general effect of the picture is sometimes drawn, and this, printed in a neutral gray, forms the basis of the finished print. The other stones are drawn separately to correspond with the different colours required to produce the necessary effect. It will be easily understood that in arranging the various colours with their varying degrees of depth on the different stones, the proper amount of force to be given to each, and the effect

likely to be produced by printing one tint over another, have to be considered, and give scope for a great deal of professional skill. There are many different methods of drawing the tints on the stone which are too technical for our limits. The finest work is done by stipple, drawn by hand with a fine brush, a method in which French and German artists on stone are very skilful. The colour stones are printed in the manner already described, except that coloured inks are used instead of black. The different colours, varying in number from four or five to twenty or thirty, being printed by separate impressions on the same paper, it is obvious that great care is necessary to see that every impression is exactly fitted to the others, or exactly *registered*, as it is called. Several mechanical appliances are used to secure this exactness. When the necessary number of impressions have been printed and the stone has to be cleaned for another subject, the surface must be laboriously polished down till every vestige of grease is removed.

Such is a brief outline of the different methods employed in lithography, but each method is capable of infinite number of variations in the hands of different operators.

Lithographic presses vary as much in construction as those for the letterpress. The hand-press is very simple. The stone is placed on a movable table, and a *typoan*, an iron frame covered with leather, folds down over the paper when placed on the stone. It is then rolled under the *scraper*, generally a piece of boxwood fixed in an upright, which applies the pressure. The damping and inking are done by hand.

The first self-acting lithographic machine, introduced into Britain by Siehel of Berlin and Vienna, failed from the fact that it was constructed, like the hand-press, with a scraper arrangement for the impression. This produced too much friction, rendering speed dangerous, and work difficult to keep on the stone; and it was not till about 1860 that the machine as at present in use, with a cylinder for the pressure, was introduced from France. It is somewhat an adaptation of the letterpress single-cylinder machine (see *PRINTING*), and a very brief description will suffice. The stone is placed on a movable bed, which can be raised or lowered according to the thickness of the stone. The sheet is fed in at the top of the cylinder, whence a gripper arrangement leads it over the stone. At one end are the damping-rollers, which are covered with some soft absorbent fabric; and at the other the inking-rollers, covered with the finest French leather, with inking-table, duct, and distributors. The stone passes first under the dampers, then to the inking-rollers, thence back to the cylinder to print the impression, and so on *ad infinitum*.

Zincography, the invention of Eberhard of Bavaria, is an application of lithography to zinc plates instead of stones, with some necessary modification of the etching and printing. Its only advantage is in connection with very large subjects, as the zinc is more portable and less liable to breakage than stone.

See G. A. Audsley, *Chromo-lithography*, a popular treatise (44 plates), and W. D. Richmond, *The Grammar of Lithography and Colour and Colour Printing as applied to Lithography* (6th ed. 1887), both in Wyman's Techn. Series.

Lithology (*lithos*, 'a stone') is a name sometimes used for that division of geology which considers the constitution and structure of rocks, apart from their relations in time or position to each other. See *GEOLOGY*.

Lithomarge, an earthy or clay-like mineral substance, sometimes called *Mountain Marrow*

(Ger. *Steinmark*), consisting chiefly of silica and alumina, with oxide of iron and various colouring substances, derived from the decomposition of various minerals. It is soft, greasy to the touch, and adheres strongly to the tongue. It is generally white, yellow, or red, often exhibiting very beautiful colours. It is found in Germany, Russia, &c., also in the tin-mines of Redruth in Cornwall.

Lithophagida (Gr., 'stone-eaters'), a term sometimes applied to the molluscs which bore holes for their own residence in rocks. See BORING-ANIMALS.

Lithotomy (Gr. *lithos*, 'a stone;' *tomē*, 'the act of cutting'), the technical name for the surgical operation popularly called *cutting for the stone*. As most of the symptoms of stone in the bladder (which are noticed in the article CALCULUS) may be simulated by other diseases of the bladder and adjacent parts, it is necessary to have additional evidence regarding the true nature of the case before resorting to so serious an operation as lithotomy. This evidence is afforded by *sounding* the patient—a simple preliminary operation, which consists in introducing into the bladder, through the natural urinary passage (the urethra), a metallic instrument, by means of which the stone can be plainly felt and heard.

Lithotomy has been performed in various ways at different times, both in the perineum and above the pubes. The earliest form of lithotomy is known as *cutting on the gripes*, or *Celsus's method*. It received the former name from the stone, after being fixed by the pressure of the fingers in the anus, being directly cut upon and extracted. The *Morison method*, founded on the erroneous idea that membranous parts would not heal after incision, while their dilatation was comparatively harmless, was the operation mainly in vogue for nearly 200 years, till Frere Jacques introduced what is essentially the method now in use. Cheselden (1727) and Liston in the first half of the 19th century perhaps most deserve mention among the many surgeons who have subsequently improved upon the original operation.

The *lateral operation*, so called from the lateral direction in which the incision is made into the skin of the perineum and the neck of the bladder, in order to avoid wounding the rectum, is that which, with various minor modifications, is generally employed at the present day. Frere Jacques seems to have devised the method and to have practised it with much success; and in 1702 he published a description of it. The advantage of this operation, by which a free opening, sufficiently large for the extraction of all but very large stones, can be made into the bladder without laceration of the parts or injury to the rectum, was immediately recognised by the leading surgeons of the time, and the Marian process was at once universally given up. Other varieties of the perineal operation are termed median, bilateral, &c.

The *suprapubic* or *high* operation was first performed by Pierre Franco in 1561, and has occasionally been employed ever since. It has recently been proposed by some surgeons to use it in preference to perineal lithotomy in the majority of cases; but it is generally reserved for stones of large size which cannot be crushed and are difficult to remove through the outlet of the pelvis.

From the shortness of the female urethra and the extent to which it can be dilated, and, additionally, from the comparative rarity of calculous affections in women, the operation of lithotomy is seldom required in the female sex.

The danger of the operation increases with the age of the patient. Statistics of 1827 cases of lateral lithotomy in England, collected by Sir

Henry Thomson, show a mortality gradually rising from 5·7 per cent. in the patients under twelve years of age to more than 31 per cent. in those over seventy. The more general adoption of lithotomy has greatly diminished the number of cases in which lithotomy has to be resorted to.

Lithotrity (Gr., 'stone-crushing'), the surgical operation of breaking up a stone in the bladder into such small fragments that they may readily be expelled by the urethra. Although the importance of such an operation has been recognised from the earliest time, a French surgeon, Civiale, who commenced his researches in 1817, but did not perform his first operation till 1824, may be regarded as the discoverer of lithotrity. The instrument by which the disintegration of the stone is effected is introduced in the same manner as a catheter or sound into the bladder, and, after catching the stone, either bores, hammers, or crushes it to pieces. The stone is grasped by the blades of such an instrument as that shown in the figure, and the blades are then forcibly approximated to each other by means of a screw. The various fragments are gradually broken down in the same way till they are small enough to be discharged through a catheter introduced for the purpose.

Since the operation was first introduced, the instruments employed both for crushing the stone and for evacuating its fragments have gradually been improved; and experience has shown that this method is capable of superseding lithotomy in the adult in the vast majority of cases where an operation for stone is necessary.

It used to be considered advisable in the case of all but very small stones to crush and remove only a portion of the calculus at one time. To Bigelow of New York belongs the credit of recommending (in 1878) the method now adopted by almost all surgeons. He gave it the name of *litholapaxy* ('stone-evacuation'), but it only differs from lithotrity in that the procedure is completed at one sitting. This improvement was an outcome of the teaching of Otis of New York, who found it possible to introduce instruments of larger size, and therefore more effective than had been previously considered safe.

In adults the only conditions which generally make lithotrity inadvisable are 'extreme size, with hardness of structure in the calculus itself, and continued narrowness or other obstruction in the urinary passages, rendering the employment of adequate instruments impossible' (Sir H. Thomson). In children the risk attending lithotomy is much less than in adults; but the difficulties of lithotrity, in consequence of the small size of the urethra, are much greater; in boys, therefore, the former operation is still generally preferred, except in the case of very small stones.

Lithuania, a former grand-duchy of Europe, composed of three groups of territory: (1) Lithuania proper, or Litva, corresponding to the modern Russian government of Vilna, with Troki; (2) the duchy of Samogitia; (3) Russian Lithuania, comprising Polesia, Black Russia or Novogodok, White Russia or Minsk, Meislav, Vitebsk, Smolensk, Plotzk, and Polish Livonia. But in the 15th century Lithuania extended as far south as Odessa and the Sea of Azov, and as far east as the river Moskva. The Lithuanians, a race to whom belong the Letts (q.v.) of Livonia, the Courrs of Courland, and the Bessarabians or ancient inhabitants of East Prussia, constitute one of the main divisions of the Indo-



European stock; to them are sometimes added the Yatvyags or Yadvings, who dwelt on the upper tributaries of the Bug and Niemen, thus making about 3½ millions in all. The Jmuds, 700,000 in number, are a branch of the Lithuanians proper. The Lithuanian tongue is spoken by about 1½ million; in some respects it comes nearer Sanskrit than any other Aryan language, though it contains a strong admixture of Slavonic words. Along with Lettish and the extinct Old Prussian it constitutes the Baltic family of the Aryan branch of languages. Owing to its many archaic forms and the early stage of its development, it possesses great value for students of comparative philology. The literature is exceptionally rich in poetry, popular tales, &c. The poetry is frequently full of the very breath of nature. See works by Schleichler (1854 to 1876) and Bozzenberger (1877 and 1882), and collections of songs by Rhesa and Kirschat (1843), Nesselmann (1855), Brugmann and Leskien (1882); Veckenstedt's *Mythen, Sagen*, &c. (1883); Ch. Bartsch, *Litauische Melodien* (2 parts, 1887-90). A Lithuanian literary society was formed in Tilsit in 1879.

As a race the Lithuanians are fair and well built, with fine features and blue eyes. They have strong religious temperaments, and, though they belong to the Roman Catholic and Greek Catholic churches, they cling tenaciously to heathen reminiscences and customs. They have been kept in a state little superior to serfdom by German and Polish land-owners, but since 1863 the Russians have allowed them to become, to some extent, owners of the soil. Agriculture, cattle-breeding, and bee-keeping are the principal occupations. The country they inhabit is covered with vast primeval forests and with numerous marshes and lakes. These circumstances have impressed traits of peacefulness, melancholy, and loneliness, but at the same time of sweetness, upon both the national character and the national songs. For many centuries worship was performed in the forests, and great oaks are still objects of religious veneration. They have never had any towns, only villages, and have always relied for protection upon the dense forests and the extensive marshes. Nothing authentic is known as to the history of this people prior to the 13th century. The first prince to gather the scattered tribal chiefs around him was Ringold (1230-35); his policy of centralisation was continued by his son Mindovg (died 1263), who even consented to be baptised, but afterwards apostatised. During these reigns the Lithuanians waged almost incessant war against the Livonian order and the Teutonic Knights (see LIVONIA). Olگرد (1315-77), after reviving (along with his brother Keistut, the legendary national hero of the Lithuanians) the principality of Lithuania, extended his conquests into southern Russia. His son Jagiello (1377-1434) married the heiress of Poland (q.v.), thus forming the first link of connection between these two states; the last link was welded in 1569 by their complete political unity. In the interval Lithuania had been governed by grand-dukes appointed by the king of Poland. By the three partitions of Poland Russia acquired the bulk of the grand-duchy (Polotsk, Troki, Brest, Novogorod Syversk, and the governments of Grodno, Kovno, Vilna, Moghileff, Vitobsk, Minsk); the rest fell to Prussia, but passed in 1814 to Russia. See *Histories* by Schlozer and Gebhardt (Berlin, 1785) and Ledewit (Paris, 1861).

Litmus is a well-known colouring matter, which is obtained from several lichens, but chiefly from *Lecanium tataricum*. The lichens are powdered and digested with ammoniacal fluids (urine, for example) till they undergo decomposition. Alum, potash, and lime are then added, and the mixture is allowed to stand till the maximum degree of colour

is observed. Sand and chalk are added to give a due degree of solidity, and the mass is then dried in cubes, and is ready for the market. The exact nature of the changes which ensue is not altogether known; it is, however, certain that the pigment is originally red, and that it only becomes blue on the addition of alkalis or of lime. This blue colour is again changed into a red on the addition of a free acid. The use of litmus-paper and tincture of litmus for the purpose of detecting the acidity of fluids, &c. is known to every student of chemistry. See TEST-PAPERS.

Litre, the unit of the French measures of capacity, both dry and liquid. It is the volume of a cubic decimetre (see METRE), and contains a kilogramme of water at 39.2 (4 C.) in a vacuum; it is equal to 0.2200967 British imperial gallon, and is therefore less than a quart. 4½ litres being roughly equal to a gallon. The litre is subdivided decimally into the *decilitre*, *centilitre*, and *millilitre* (respectively $\frac{1}{10}$ th, $\frac{1}{100}$ th, and $\frac{1}{1000}$ th of a litre). Ten litres make a *decalitre*: 100, a *hectolitre*: 1000, a *kilolitre*. The hectolitre is the common measure for grain, and is equal to 0.3439009 British imperial quarter, or nearly 2½ imperial bushels.

Little, THOMAS. See MOORE.

Littleborough, a town of Lancashire, 3½ miles NE. of Rochdale, of which it is virtually a suburb, and in the manufacturing industries of which it shares. Pop. of parish, 10,496.

Little Falls, a post-village of New York, on the Mohawk River, 73 miles WNW. of Albany, on the line of the Erie Canal and of two railways. The Mohawk here passes through a narrow rocky gorge, with falls of 44 feet, giving water-power to several mills and factories. Pop. 8910.

Littlehampton, a seaport and watering-place on the coast of Sussex, 18 miles W. of Brighton and 63 SW. of London. It is the port for Arundel. Pop. 3926.

Littlemore, a hamlet 2½ miles SSE. of Oxford, famous for its associations (1828-43) with Newman.

Little Rock, the capital of Arkansas, is situated on the south bank of the Arkansas River, 280 miles from its mouth, and 345 miles by rail SSW. of St. Louis. It contains the state capitol, prison, and asylum for the blind and deaf mutes, a United States arsenal, a Roman Catholic cathedral, court-houses, a university, a medical school, &c. Pop. (1880) 13,138; (1890) 25,874.

Littleton, or LITTLETON, SIR THOMAS, English jurist, was born in 1402 at Frankley House, near Bromsgrove, Worcestershire, his mother being the heiress of Thomas de Littleton, lord of the manor of Frankley. He was recorder of Coventry in 1450, king's sergeant in 1455, in 1466 judge of common pleas, and in 1475 a knight of the Bath. He died on 23d August 1481. Littleton's 'authentic reputation' (Fuller's phrase) rests on his work on *Tenures*, which was originally written in Norman-French, or rather law French. It treats of the English law relating to rights over land, and was the first scientific attempt to classify the subject. It seems to have been first printed in the year of its author's death, if not before, and passed through numerous editions. The first translation into English was made probably as early as 1500. It was the original text that Coke commented upon in his famous *Coke upon Littleton* (see COKE). The changes in the laws relative to property have greatly diminished its value, and it is now little studied by lawyers; yet it is considered a model from the clear and logical manner in which the subject is handled.

Littoral Deposits, accumulations formed in shallow water along a shore line. They are

generally gravelly and arenaceous in character, and exhibit rapid alternations of finer and coarser grained materials.

Littré, MAXIMILIEN PAUL EMILE, an eminent French philologist and philosopher, was born in Paris, 1st February 1801. He first studied medicine, but ere long gave himself to philology, mastering Sanskrit, Arabic, Greek, and the chief modern languages. One of his first tasks was a translation of the works of Hippocrates (10 vols. 1839-61), which at once opened for him the door of the Academy of Inscriptions. Littré held democratic opinions, distinguished himself on the barricades in 1830, and was one of the principal editors of the *National* down to 1851. He embraced Comte's Positivism with great ardour, and defended it ably in pamphlets and in journal articles, but he did not share the disciples' indiscriminating enthusiasm for the Master's later works. Disappointed at the results of 1848, he retired from active politics, resigning even his office of municipal councillor of the city of Paris. Returning to a life of study, Littré continued his researches in the history of medicine, at the same time working ardently at the history of the French language. His article, *La Poésie Homérique et l'Antique Poésie Française* (1847), attracted great attention. It was an attempt at the translation of the first book of the *Iliad* in the style of the Trouvères. The Academy of Inscriptions chose Littré, in place of Faurlé, in 1844, to be one of the commission charged with continuing *L'Histoire Littéraire de France*, and he is one of the authors of vols. xxi.-xxiii. In 1854 he was appointed editor of the *Journal des Savants*. Littré's principal work is his *Dictionnaire de la Langue Française* (4 vols. 1863-72; supplement, 1878), a monument of patience and erudition. This splendid work—the real *thesaurus* of the French language—did not prevent the French Academy in 1863 from rejecting its author, whom Bishop Dupanloup denounced publicly as holding immoral and impious doctrines. Just before the siege of Paris Littré's friends compelled him to quit the capital. In January 1871 Gambetta appointed him professor of History and Geography at the École Polytechnique. Next month he was chosen representative of the Seine department in the National Assembly, where he sat with the party of the Left. On the 30th December 1871 the French Academy at last admitted him to membership; whereupon Bishop Dupanloup resigned his seat. Littré published *Médecine et Médecins* in 1872. In 1875 he received honours from Leyden and from the Austrian Academy. He died at Paris, 2d June 1881.

Other works of Littré's were: French translations of Strauss's *Life of Jesus* (1839-40) and of Pliny's *Natural History*; *Histoire de la Langue Française* (2 vols. 1862); *Parole de Philosophie Positive* (1859); *Auguste Comte et la Philosophie Positive* (1863); *Auguste Comte et Stuart Mill* (1865); *La Science au Point de Vue Philosophique* (1873); *Littérature et Histoire* (1875); *Éléments de Philosophie Positive et de Sociologie Contemporaine* (1876); and *Œuvres Complètes d'Arnould Carrel* (1857). His *Études et Mémoires pour servir à l'Histoire de la Langue Française* (1880) contains an interesting account of the origin of his great Dictionary. See also Sainte-Beuve's *Notice sur M. Littré* (1863); the *Edinburgh Review* (1882); and the *Century* (1884).

Liturgy, a word derived from the Greek *leitourgia*, signifying originally a 'service,' such as those rendered by citizens to the state. By the translators of the Septuagint it was applied to public worship, and among the Greeks the sense is now limited to the celebration of the eucharist. The word at one time enjoyed a wider signification, and in English the term liturgy is still sometimes loosely used to indicate a general body of forms

for public worship prevailing in a particular community; but by the more correct writers it is used in the same exclusive sense as is the original by the Greeks. The present article is designed briefly to sketch the history and development of the forms used in the celebration of the eucharist or Lord's Supper, exclusive of those employed only by Protestants.

With regard to the form used by Christ Himself (Matt. xxvi. 26-28; Mark. xiv. 22-24; Luke. xxii. 19, 20; 1 Cor. xi. 23-25) only three features are recorded, besides the taking hold of the bread and the cup. These are that He (1) gave thanks (*eucharistias*) and blessed, that (2) He brake, and that (3) He administered. To these we must necessarily prefix, on any subsequent occasion, the laying of the table and the placing upon it of bread and wine. It appears from Acts, xx. 7, 12, that the ceremony was preceded by a sermon or discourse, and from 1 Cor. xiv. 16 that the blessing was regarded as identical with or part of the thanksgiving (*eucharistia*), which was the name given to the whole of the principal formula; while we learn from Tim. ii. 1, 2, that the thanksgiving contained a prayer for all men, and from 1 Cor. xiv. 16 that at the conclusion of the thanksgiving the word 'Amen' was answered. The New Testament also contains no less than five directions (Rom. xvi. 16, 1 Cor. xvi. 20, 2 Cor. xiii. 12, 1 Thess. v. 26, 1 Pet. v. 14) with regard to the giving of a religious kiss, and it is hard to escape the conclusion that this ceremony must have been associated with the principal act of worship, the eucharistic celebration.

Whether any such thing as a liturgy had yet been committed to writing in the time of the apostles is unknown. At any rate it is evident from 1 Cor. xiv. 16 that the use of a fixed form was not obligatory. Moreover, there are certain passages that occur both in the writings of St Paul and in the so-called Clementine liturgy, which, in the judgment of some of the most eminent critics (notably Dr Neale), appear from the context in each case to be quoted in the epistles from the liturgy, and not in the liturgy from the epistles. It is a plausible conjecture that a form or forms may have been drawn up as models, without the celebrant being tied to their strict use.

The martyr Justin in his first defence of Christianity gives a scanty and confused account of the liturgy, from which, however, it is possible to gather the six points above mentioned, with three additional facts—viz. that portions of the Old and New Testaments were read before the sermon, that after the sermon there were prayers of an intercessory character, and that the kiss was given after these prayers and before the bread and wine were placed upon the table. Justin also mentions that the thanksgiving was very long.

Some words used by Justin may mean that in his day a custom already prevailed which in any case was certainly in force very soon after. This was the rule of secrecy (*Disciplina Arcaica*, q.v.) by which all unbaptised persons, including those who were actually under preparation for baptism (*catechumens*), were dismissed from the assembly as soon as the sermon was over, and which was later extended so as to conceal from them as far as possible the knowledge of what afterwards took place. This rule has caused Western writers to divide the liturgy into two parts, the first, up to the sermon inclusive, being termed the Mass of the Catechumens (*Missæ Catechumensium*), and the rest the Mass of the Faithful (*Missæ Fidelium*). Other persons unfit to be present at the celebration were dismissed at the same point. This twofold division made by western writers must not be confused with a twofold division made by the Easterns, who call all the portion which follows the commencement of the

thanksgiving by the distinctive name of the *Anaphora* ('offering'), whence the terms Pro-Anaphora and Anaphora to distinguish the two portions.

The Clementine liturgy is found embedded in the compilation called the Apostolic Constitutions (q.v.). It is not known where it was used, but as it is in striking harmony with the account given by Justin, who was writing at Rome, it seems probable that it is the form once used at any rate in that city.

The rule of secrecy is probably the main reason for the extraordinary scantiness of allusions to the eucharist among early Christian writers. Into these it is needless to enter here. It suffices to say that all known liturgies later than the so-called Clementine are divisible into five distinct schools, called respectively the Roman and the Ephesian, which are Western, and the Hierosolymitan, the Babylonian, and the Alexandrian, which are Eastern. All these, however, show their common origin by consisting of certain main parts, although all do not contain all these parts, and the parts themselves are not always arranged in the same order. These parts are of course called by different names in different countries; those used by English scholars, which are mostly derived from those of the Roman liturgy, will be here given in brackets, and generally employed. The ceremony ordinarily begins with some opening hymn (introit), and there is often a short litany, always with the Greek response of *Kyrie eleison*. There is often, also some confession or acknowledgment of sin and prayer for pardon. There is then a prayer or prayers, and some portions of the Scriptures are read, interspersed with psalms or hymns, and ending with a reading from the Gospels, after which is usually preached the sermon, if there be one. The next stage (offertory) is the spreading upon the altar of a piece of linen or silk (corporal), and the placing of the bread (host) and wine upon it, except in the case of the pure Alexandrian form, where this is done first of all. Except among the Armenians, a few drops of water are added to the wine. There are in any case some prayers. After this, except in the Roman school, the kiss (Pax, 'kiss of peace') is given. The thanksgiving is then introduced with some form of the words, 'Lift up your hearts' (*Suscina corda*)—Answer, 'We lift them up unto the Lord;' 'Let us give thanks unto our Lord God'—Answer, 'It is meet and right.' The first part (preface) of the thanksgiving always closes with some reference to the angels who never cease to cry aloud, and here the people join in singing some short hymn, beginning 'Holy, holy, holy, Lord God of Sabaoth' (*Sanctus* or Triumphant Hymn). The continuation (canon) of the thanksgiving then comes to a rehearsal of the circumstances of the institution of the eucharist, reciting the words of Christ (consecration), and this again is followed by a brief remembrance of His life, and by a particular prayer, which will be spoken of hereafter. The thanksgiving closes with a short doxology, and 'Amen' is answered. The Lord's Prayer is then said, either before or after which the Sacrament is broken, and a portion put into the chalice. About this point the sacrament in both kinds is often lifted up (a ceremony properly termed the Elevation, but now often the Little Elevation), as though to invite the communicants to approach, and the words 'the holy to the holy' are usually uttered. In the Roman school the kiss is given now. Next comes the administration of the communion, preceded by some prayers of preparation, and accompanied or followed by a psalm or hymn. The whole service ends with prayers of thanksgiving for the communion received (post-communion), and a benediction. It will be remarked that in the above sketch

one important feature is not mentioned—viz. the prayer for all men (the Great Intercession). It occurs in all the liturgies, but it is placed at different points, and it is in the particular point at which this prayer occurs that the difference between them mainly consists. All the liturgies also have adopted the use of the Nicene Creed, though they differ as to the point at which they interpolate it; but, as the creed itself dates only from the 4th century, and forms no integral part of the ceremony, this is a matter of little moment. It is to be remarked that in all the rites some portions of the service (even such as are not personal to himself) are said by the priest inaudibly (*secretis*), a singular custom which may perhaps have arisen after the introduction of congregational singing, and owe its origin to the desire, on the one hand, not unduly to protract the service, and, on the other, not to omit either the singing or the prayers.

In the West the use of the word liturgy has been almost entirely superseded, except in the disquisitions of the learned, by some form of the word which appears in Latin as *missa* and in English as *mass*. The derivation of this word has been disputed, but it is admitted that it is connected with the proclamation, *He: missa est*, often made at the end of the Roman mass, and it may now be regarded as certain that it is a mere corruption of *missio*, and means simply a dismissal. In the Western rites the bread is always unleavened. The language is normally Latin, which was the common literary tongue when these rites were composed, and has never been changed. They have a custom, introduced about 1100 A.D., that, immediately after the utterance of Christ's words of institution, in each case the celebrant should lift the sacrament above his head, and this is now commonly called by Westerns the elevation, while the true elevation, or lifting of the sacrament, as though to intimate that the moment of communion is at hand, is by them called the Little Elevation. By a custom sanctioned in the 15th century, the celebrant only (with the exception of the kings of France at their coronation, and a few of the assistants at a papal high mass) communicates from the chalice. The manner of conducting the service is divided into High, Sung, and Low Mass. A High Mass is sung, with a deacon, sub-deacon, and other assistants, and the use of incense. A Sung Mass is sung by the priest and choir or congregation, but there is only one clerk and usually no incense. A Low Mass is read by the priest with one clerk, and without either music or incense. A Low Mass occupies about half an hour, the others (with simple music) about three-quarters of an hour. Very many priests celebrate it every day, so that it sometimes takes place scores of times in the same church on the same day.

(A) The Roman liturgical family is often called the Petrine, and is traditionally ascribed to the apostle Peter. It is certain, however, that the early Roman Church was a Greek church. When its liturgy became Latin is unknown; possibly the Latin liturgy is of African origin. There is no trace of the change before the 4th century. The distinctive features of the Roman family are the peculiar position of the Pax, and that the great intercession (except the prayer for the dead, which has perhaps, however, been misplaced) occurs between the Sanctus and the Consecration. It is represented by two main rites.

(a) The Roman. This is the common Roman mass familiar in most parts of the world. The Roman liturgy has several varying forms, such as that used by the Dominicans (who, as in the Alexandrian school, place the bread and wine on the altar at the beginning) and the Carthusians. These preserve the usages of particular times and places in the middle ages, as was also the case with

the Sarum, the Aberdeen, and other medieval rites. There are also some French variations, especially that of the church of Lyons, but their peculiarities may have to do with survivals from the Gallican (see below). It has also been translated into Slavonic, into Armenian by the Dominicans, and into Chinese by the Jesuits, but of these the Chinese has never come into use, and the Armenian is extinct.

(b) The Ambrosian liturgy is that of the ecclesiastical province of Milan. Its main interest for scholars lies in the fact that it is a development, parallel to, but independent of, the present Roman liturgy, from some earlier form of the latter, which has been the common parent of both, and that it preserves some features of this parent which have been lost or much obscured in the Roman use.

(B) The origin of the Ephesian or Ephesine family of liturgies is traditionally ascribed to St John. Its distinctive feature is that the great intercession does not form part of the thanksgiving, as directed by the apostle Paul, but is placed after the close of the offertory, and immediately followed by the Pax, before the thanksgiving begins. It is almost extinct, but was once represented by at least three branches, of which one only survives. (a) The Mozarabic liturgy is the ancient liturgy of Spain, and owes its present name to the fact that those who continued to practise it had lived mixed with the Arab population. It would have died out altogether had not the celebrated Cardinal Ximenes established a special chapter to celebrate it in the cathedral of Toledo, and sanctioned it for the holders of a few isolated benefices, so that the practice of this liturgy is now confined to a side-chapel in the cathedral of Toledo, and the use of a few individuals. It is written in a very peculiar dialect of degraded Latin, and the existing texts are corrupt, some portions having been avowedly added by Cardinal Ximenes, under whose care all the service-books of this rite were edited.

(b) The Gallican or ancient liturgy of Gaul is totally extinct. No copy of it is known to exist, and the attempt to reconstruct it from fragments and incidental notices has largely exercised the industry and ingenuity of the learned. (c) The Celtic liturgy, as imported by Patrick into Ireland and by Columba into Scotland, was undoubtedly Gallican in form. Gillis the Wise introduced the Roman liturgy in the 7th century, and it gradually took the place of the other, which was finally stamped out in Scotland by St Margaret, and soon afterwards in Ireland, where it lingered a little longer. Its remains are more scanty than those of the Gallican. What liturgy was used by the early British (i.e. Cymric) Christians is unknown. It may have been either Roman, Gallican, or both. There is even a mention of a Greek liturgy in Wales. In the three Eastern families the bread (except among the Armenians) is always leavened. They are celebrated as a rule in the classical literary tongue of their respective countries. With regard to them it has to be observed that, while the majority of the Christians who use them belong to the Orthodox (vulgarly called the Greek), the Nestorian, or the Monophysite communions, there is everywhere a minority who adhere to the communion of Rome, and that, while employing, with only very slight differences, the same liturgies, there is between them a very grave doctrinal difference as to the consecration which cannot be ignored by the liturgical scholar. In each of these families the place of the prayer which follows the remembrance of the life of Christ in the Roman liturgy is occupied by a form invoking the Holy Ghost to descend upon the elements that they may be the body and blood of Christ. The Catholics maintain that the consecration is effected solely by the words of Christ, and that this prayer is therefore to be understood in

the same sense as in the corresponding one in the Roman liturgy—viz. as merely asking that the sacrament may be blessed to the receivers, and that the Holy Ghost is invoked to descend upon it in order to enable the communicants to 'discern the Lord's body' (1 Cor. xi. 29), in a manner somewhat similar to that in which He descended upon Christ's natural body at the time of His baptism, in preparation for the work of His ministry. On the contrary, the bulk at least of the Easterns outside the communion of Rome maintain that this invocation is essential (if not indeed the sole essential) to the consecration, which is not effected, or at least completed, until it has been uttered. It may be added that the Eastern Catholic clergy are in the habit of saying low masses without music and generally without incense, and that their celebrations are as frequent as those of Latins; while among the Orthodox and Monophysites there is a daily celebration in monasteries and cathedrals, but in ordinary churches only on Sundays, holy days, and special occasions; and among the Nestorians, although the celebration is nominally prescribed for all Sundays, Fridays, and holy days, it is not uncommon to find only a sort of Mass of the Catechumens performed even upon many Sundays.

(C) The origin of the Hierosolymitan or Jerusalem family of liturgies is ascribed to the apostle James. Its distinctive feature is that the great intercession occurs just before the closing doxology of the thanksgiving. (a) The earliest existing form is a liturgy in Greek, called by the name of the apostle, which is now obsolete everywhere, though it is said to have long lingered on in some of the Greek islands, for St James's Day only. However ancient may be some portions of it, especially in the thanksgiving, it contains in its present form comparatively recent features, the dates of which are known. (b) The Constantinopolitan. There is a liturgy (originating from the Church of Caesarea) called by the name of St Basil, abridged from that of St James, and of which the inaudible parts of the anaphora have again been abridged, under the name of St John Chrysostom, although it is very uncertain how far Basil and Chrysostom are really to be credited with the work. These liturgies, or rather this liturgy (since the differences are only in the inaudible part), is the only one in use in the Orthodox communion, and is celebrated in Greek, Arabic, Slavonic, and Georgian. A stranger entering a Greek church is liable to be struck, if not confused, by the way in which the actual liturgy, mostly inaudible, is overlaid with litanies and hymns of varying length, and still more by the almost entire concealment of the altar behind the screen called the *ikonostasion* ('image-stand'). (c) The Greek rite in Italy. A good many Italians, especially in the south, belong to the Greek rite. They now use the Constantinopolitan liturgy. There was once, however, a native Sicilian Greek liturgy, of which a text has been published by Assemani, and of which certain peculiar local practices are probably survivals. The members of the Basilian order in Italy had also a peculiar form of Greek liturgy, which may now be regarded as extinct, as the present government has suppressed all their monasteries, and the surviving members have mostly if not universally adopted the pure Constantinopolitan. Their liturgy was generally regarded as the Constantinopolitan affected by Westernisms, but this point has not been sufficiently investigated. (d) The Armenian liturgy is an adapted translation of the Greek St Basil. The language is Armenian. There is no *ikonostasion*, but a veil is sometimes drawn round the altar. The celebration of this rite is far more pompous and spectacular than that of any other used among Christians. (e) The Syriac liturgy of St James appears to be a free translation from an

early form of the Greek. Devout Syrian ecclesiastics seem to have had a sort of passion for composing paraphrases of the inaudible parts of the anaphora, and there exist at least some forty such compositions, sometimes dignified by the name of liturgies. This liturgy of St James is that used by the section of the native Christians of India ('Christians of St Thomas') who have abandoned the communion of Rome and their own ancient Babylonian rite, and embraced Monophysitism.

(f) The Constantinopolitan rite has had a great effect upon the forms of the Alexandrian or Egyptian liturgy, which is treated below under E.

(D) The origin of the Babylonian school of the liturgy, otherwise called the Assyrian or Chaldean, is ascribed to the apostle Thaddæus. The language is Syriac. The distinctive feature is that the great intercession occurs after the remembrance of the life of Christ and before the invocation, which immediately precedes the closing doxology of the thanksgiving. The oldest existing form is that of the liturgy called 'of the Apostles,' and is certainly of profound antiquity. There are two paraphrases of the anaphora of this liturgy, one of which is called the liturgy of Theodore of Mopsuestia; the other is named by the Nestorians in honour of the founder of their sect, but they appear to be as a whole older than the time of these persons. In the churches of this rite the sanctuary is a separate room, somewhat after the manner of the Holy of Holies of the Jewish temple, and the whole ceremony is of severe simplicity. The liturgy of Malabar, or original liturgy of the native Christians of India ('Christians of St Thomas'), is a form of the Babylonian liturgy of the Apostles, but is said to have suffered much ignorant meddling, under the influence of the Portuguese, at the synod of Diamper (1599).

(E) The Alexandrian liturgical family represents the form of the liturgy belonging to the Church of Egypt, and its origin is ascribed to the evangelist Mark. The properly distinctive feature is that the great intercession occurs between the *Sacrum corda* and the *Sanctus*—viz. in that part of the thanksgiving called the preface. Its existing monuments have all been corrupted by divers external influences, and their history is very obscure. (a) The normal or original form is called the liturgy of St Mark, and is in Greek. Like that of St James, it contains passages, especially in the thanksgiving, of which it would be rash to measure the antiquity, but, as we now have it, it has undoubtedly been modified under Constantinopolitan influences, and probably since the triumph of Monophysitism in Egypt. It continued to be used for many centuries by the Orthodox, but is now extinct, as they have adopted the full rites of Constantinople. (b) Renaudot has published what he believed to be an Alexandrian edition of the Constantinopolitan liturgy of St Basil. (c) At what period the Coptic or native language was substituted for the Greek is uncertain, and the present writer is inclined to the belief that it was a device of the Monophysites to popularise their heresy and emphasise their separation from the Orthodox. But whoever the translators may have been, they were confronted by the fact that the population were to a great extent bilingual; many formulae were familiar in Greek, and the theological terminology was mostly Greek. Accordingly the liturgy was translated into a sort of jargon of Coptic mixed with Greek words, many formulae were left in Greek, and the deacon was provided with a set of biddings in Greek so ample as nearly to amount to a translation of the prayers. The liturgy so produced was that which bears the name of St Cyril. It is a free translation and adaptation from that of St Mark, but from a recension earlier than that of which we possess any Greek text. It

is now almost extinct. (d) A fresh anaphora was composed, called by the name of St Basil, and in which the great intercession is transferred to the latter part of the thanksgiving, as in the Hierosolymitan family. It is now used only on some rare occasions. (e) A third anaphora was composed, called by the name of St Gregory, and this, joined to the pro-anaphora of St Cyril, constitutes the ordinary Coptic liturgy. A fresh linguistic difficulty has however arisen. Coptic is totally dead, and Arabic has become the language of Egypt. Hence the sermon is of course in Arabic, some parts of the liturgy are always, and the Creed and Lord's Prayer often, said in Arabic; each portion of Scripture is read in Arabic as well as Coptic, and Arabic hymns are introduced. The service is, in fact, trilingual. Coptic churches are generally very plain, the altar is surrounded by a wooden partition, and the ceremony is not showy. Incense is burned almost without ceasing from the beginning until the consecration. (f) The Abyssinian liturgy is in Ethiopic, and is called that of the Apostles. It is an adapted translation of the Coptic St Cyril. Here also there has been a considerable tendency to compose paraphrases of the anaphora, of which as many as ten are known to Western scholars.

It remains to mention a few externals which are common to all these families. All light wax tapers during the celebration, however bright may be the natural light (see LIGHTS), and incense (q.v.) is universally burned. Fans (q.v.) came into use in the southern countries where flies are troublesome, but as a rule they have now become mere ornaments carried in processions. As to vestments, the Chasuble (q.v.) is universally worn by the celebrant; nor is there any trace of a time when it was not. As, however, it is originally a mere round piece of stuff with a hole in the middle for the head, the hands can only be used while wearing it by raising it at the sides or in front. Hence in the Roman, Ephesian, and Babylonian families it is cut up at the sides and hangs down before and behind; among the Orthodox the front part below the breast is cut away; in the Alexandrian rite, and by the Armenians and some of the Syrians, it is entirely split up the front, and becomes a mere cloak. In all the families is also worn a long gown down to the feet, which is in English called an *Alb* (q.v.). This, with its accompanying girdle, of course represents the long tunic worn by orientals. The *stole* is a strip of stuff worn by the priest round his neck, and by the deacon over his left shoulder. It seems to be the *tallith* or religious garment of the Jews, which must of course have been worn in prayer by Christ and His earliest disciples, and which, as usually arranged, exactly resembles a stole. The *maniples* (in Greek, *epimanikia*) are cuffs seemingly used simply to confine the sleeves of the alb; the corresponding object worn by Latins, however, is put on the left arm only, and has a long flap; and some have maintained that it was originally a pocket-handkerchief. The *amice* is really a veil or covering for the head, and by the Copts it is so worn until the thanksgiving. In the other families it is generally pushed down upon the neck, and the Armenians, by embroidering it, have made it into a sort of ornamental collar.

The liturgies used by Protestants are either, as among Anglicans, adaptations of the Roman rite, or, as among Presbyterians, forms altogether newly invented, based upon Scripture and convenience only. The latter process has resulted in some interesting coincidences, such as the general introduction among Presbyterians of the ceremonial in bringing of the bread and wine at the offertory, called by the Greeks 'the Great Entrance;' while one school gained the popular name of 'Lifters,' from practising the Elevation. It may, however,

be remarked that Spanish Protestants have always shown a great leaning to the Mozarabic liturgy, the reason for which is plain enough, since it is not Roman, and is undoubtedly ancient and intensely national; and it is not improbably owing to the influence of Spanish refugees in London that in the second (and present) Anglican liturgy the great intercession (the 'Prayer for the Church Militant') has been placed in the offertory. The liturgy used by the body commonly known as Irvingites is remarkable for its literary merit.

Liturgical literature is exceedingly voluminous. For a single volume the reader may be referred to the Rev. C. E. Hammond's *Liturgies Eastern and Western* (Oxf. Clai. Press, 1878). Much matter will be found in the late Dr Neale's *Introduction to the History of the Holy Eastern Church*. As regards the Roman and Constantinopolitan rites, books are plentiful; as to the Armenians, the *Armenian Church*, by the Rev. E. F. K. Fortescue; for the Indian Monophysites, *The Christians of St Thomas and their Liturgies*, by the Rev. G. B. Howard; for the Nestorians and Chaldeans, *The Nestorians and their Rituals*, by the late Dr Badger; and for the Copts, *The Coptic Sunday Morning Service*, by the present writer, will supply information of a practical kind; while for other or more recent studies recourse may be had to the authors cited by Mr Hammond. The doctrine of the eucharist, and its history before and after the Reformation, is treated in the articles LORD'S SUPPER, PRAYER-BOOK; see also SACRAMENT, TRANSUBSTANTIATION.

Liutprand, or LUTFRAND, an author to whom we owe much of our knowledge of the history of the 10th century, was born of a distinguished Lombard family in Italy about the year 922. He entered the service of Berengar, king of Italy; but, having fallen into disgrace, he repaired to Germany, and served the Emperor Otto I., with whom he returned to Italy in 961. Otto made him Bishop of Cremona, and afterwards sent him on an embassy to Constantinople. He died about 972. His *Antipapalis* treats of the period from 886 to 959. He wrote also *De Rebus Gestis Ottobonis Imperatoris*, covering the years 960 to 964, and *De Legatione Constantinopolitana*, a satire on the Greek court. The best edition of his works is printed in *Bertz's Monumenta Germaniæ*, vol. iii. See Köpke, *De Vita Liutprandi* (1842).

Livadia (anc. *Isobadina*), a town of Greece, 60 miles NW. of Athens, destroyed by earthquake in 1894. Pop. 5000. From it the northern part of modern Greece used to be called Livadia.

Livadia, the name of an estate, with a couple of palaces and magnificent gardens and vineyards, belonging to the empress of Russia, situated on the south coast of the Crimea, 30 miles SE. from Sebastopol. The entire neighbourhood is sprinkled with the castles and villas of Russian nobilities, who come here for sea-bathing in the autumn.

Liver. The liver is the largest gland in the body. It weighs from 3 to 4 lb., and measures about 12 inches from side to side, and 6 or 7 inches from its anterior to its posterior border. It is situated in the right hypochondriac region, and reaches over to the left; being thick behind, convex on its upper surface, where it lies in the concavity of the diaphragm, and concave below, where it rests against the stomach, colon, and right kidney. This lower surface presents a fissure dividing the organ into a right and a left lobe. The liver is retained in its position by five ligaments. Besides the right and left lobes, there are three smaller lobes. The great bulk of the organ is, however, made up of the right lobe, which is six times as large as the left. The vessels of the liver are the hepatic artery, which comes off from the cardiac axis, and supplies the organ with nutrient blood; the portal vein, which conveys to the liver the venous blood of the intestines, spleen, and stomach,

and from which (after the vessel has ramified like an artery) the hepatic veins arise and convey the blood from the liver into the inferior vena cava.

In fact, the liver is a great glandular mass placed in the path of the veins passing from the stomach

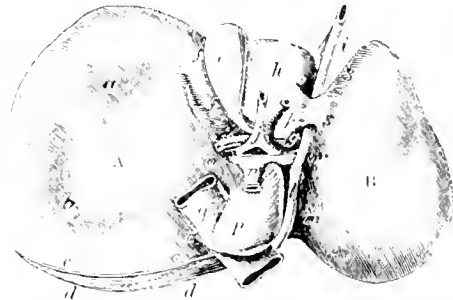

FIG. 1.—The Liver:

A, right lobe; B, left lobe; a, depression for colon; b, depression for right kidney and capsule; cc, coronary ligament, inferior layer; dd, surface uncovered by peritoneum; e, gall-bladder; ff, fissure for gall-bladder; gg, transverse fissure; h, lobulus quadratus; i, umbilical vein; j, hepatic duct; k, hepatic artery; l, ductus venosus; mm, fissure for ductus venosus; n, vena porta; o, lobulus caudatus; p, lobulus Spigelii; q, inferior vena cava; r, fissure for inferior vena cava; ss, longitudinal fissure.

and intestines towards the heart. The blood, laden with nutritious matter, has to pass through the liver before it can get into the general circulation; in its passage it comes into intimate relationship with the minute hepatic cells, which alter its constitution, abstracting or adding various constituents. The bile is one of the products of the liver cells, which, obtaining their raw material from the blood, secrete this fluid into tiny ducts (drains). These join with other vessels to form larger and larger ducts (just as veins join with other veins to form larger vessels), which finally leave the liver and pass towards the gall-bladder. Here the Bile (q.v.), which is constantly secreted, is stored up ready to be discharged into the intestine during digestion. The bile, which is of a brown, or in some animals, of a green colour, is coloured by pigments (bilirubin, biliverdin), which are undoubtedly decomposition products of hæmoglobin, the colouring matter of the blood. It appears, therefore, that the red corpuscles of the blood which contain this pigment are continually suffering dissolution, probably the old and useless cells being destroyed within the body by the agency of other cells. Whether their destruction actually takes place within the liver is not yet absolutely certain, but it is certain that the liver removes their colouring matter from the system. Occasionally it happens that the liver may have a heavier task thrown upon it than it can undertake. Thus, a rapid dissolution of corpuscles may take place from various conditions; for instance, there may be an excess of blood after a bloodless amputation, where the blood of a limb before the operation has been driven into the rest of the body; or, again, when the blood from the after birth has been allowed to flow into the body of a baby. In these cases the liver may be unable to excrete all the pigment and



Fig. 2. Diagram of Liver:

c, intestines; p, portal vein breaking up into capillaries among liver cells (c); blood subsequently passes to heart (h).

jaundice will arise. A similar condition will follow any obstruction to the outflow of bile from the liver (gall-stone, inflammation of ducts, &c.). The already secreted bile will in that case pass back into the system through the absorbent lymphatics. In the bile are certain organic salts, taurocholate and glycocholate of sodium. It is probable that these result from the destruction of albumen, perhaps that of the red blood-corpuscles. Of these salts and their rôle in the economy there is much to be learned; they are probably in part reabsorbed from the intestine into the blood.

These functions of the liver commence at an early period of intra-uterine life, the excreted bile accumulating in the intestine, and forming the greenish substance, meconium. After birth the bile may be looked upon not only as an excretion from the body, but as performing in its outward passage through the intestine the part of an aid to digestion and absorption (see BILE, DIGESTION).

But the liver has other and perhaps equally important functions to perform. It is a great store-house of food material. When the body is well nourished the liver cells store a certain quantity of fat, which they can part with during starvation. In stall-fed animals, beer-drinkers, &c. the liver is loaded with fat, while the liver (*pâté de foie gras*) of the Strasburg goose is a mass of fat, with hardly any vestige of the original tissue left.

Claude Bernard was the discoverer of one of the greatest functions of the liver. It appears that carbohydrates and proteids absorbed in a soluble form into the blood are, for the most part, seized by the liver and prevented from entering the general circulation. The liver retains them chiefly in the form of glycogen or animal starch, $C_{12}H_{20}O_{10}H_2O$; and after a good meal as much as 5 per cent. of the organ may consist of it alone. This glycogen is then discharged from the liver, probably in the form of a soluble sugar, as the economy is in need of it. We have here a wonderful provision for regulating the food supply to the tissues, for it would be of obvious disadvantage to them were they inundated with pabulum directly after each meal, and then left without any at all. Many parts of the body, the muscles for instance, are capable of storing glycogen on their own account; but this power is limited, and the great glycogen storehouse is the liver.

We have already seen that there is evidence that proteid substances are broken down in the liver. The greater part of the nitrogen of the proteid is excreted by the kidneys in the form of urea, which substance, as has experimentally been shown, has its primary origin in the liver itself. If carbonate of ammonia be injected through the organ it is converted into urea, which appears in increased quantity in the blood, and is excreted by the kidneys. After a highly nitrogenous diet urea in like manner appears in the blood, the nitrogen having separated from the proteid molecule. In birds and reptiles, where the nitrogen waste of the body is uric acid, not urea, the former substance is also formed by the liver, extirpation of the organ causing a marked diminution in the uric acid formation.

DISEASES OF THE LIVER.—The liver, like other organs of the body, is subject to disorder and disease. It is subject to congestion from exposure to cold, and it is certain to suffer from any prolonged violation of the laws of dietetics. The European living in India who persists in the food habits of a cold climate, although he lives in a warm one, is certain to develop a 'liver.' The beer drinker acquires a fatty liver, and the drunkard an organ in which the cellular elements have greatly diminished, the mass of the organ becoming mere fibrous tissue. The most important,

because the commonest, malady connected with disorder of the liver is that known as *biliousness*. The acute form, or 'bilious attack,' has been shortly noticed under Bile (q.v.); but many persons suffer habitually or for long periods from an allied condition. The symptoms are very various; but the most common are dull pain with a feeling of weight in the region of the liver, and pain in the right shoulder, usually worst after meals; a bitter taste in the mouth, with coated, yellowish tongue, dull headache, giddiness; sometimes drowsiness, sometimes sleeplessness; and generally more or less depression of spirits. The condition is most apt to occur in those who take too much or too rich food or drink, with too little exercise. It is probably caused not merely by deficient secretion of bile, but by imperfect performance of the other functions of the liver, especially the disintegration of albuminoid bodies. For the removal of the condition the most important measure is proper regulation of the patient's habits. Great care in diet must be enjoined, particularly as regards alcoholic drinks. Of these malt liquors and sweet or strong wines are the most injurious; but it is generally best to abstain from them altogether. Rich dishes must be avoided, and sugar and meat be taken in moderate amount. Exercise in the open air is very important; riding is the most, walking probably about the least, useful form. With regard to drugs, mercurials (e.g. blue pill) often give great relief; but their habitual use is dangerous. A daily draught in the morning of some saline aperient is generally desirable; and nitro-hydrochloric acid in small doses, with some bitter tonic, is often very useful. Biliousness seldom seriously shortens life, but it often grievously interferes with its enjoyment, and with the power of doing work with any vigour or satisfaction.

Congestion of the liver occurs in at least some cases of biliousness, and in inflammation of the organ; but also in consequence of disease of the heart or lungs causing interference with the return of blood through it. In long-standing cases of this disease the substance of the liver presents a peculiar mottled appearance, whence it is called *nutmeg liver*.—*Gall-stones* (see CALCULUS) and *Jaundice* (q.v.) have already been considered.

Acute inflammation (hepatitis) and *abscess* may occur in the course of other diseases, especially pyæmia; but in their most characteristic form they are much more common in hot countries, and in a large proportion of the cases accompany or follow dysentery. The symptoms are extremely variable; there may be fever, pain, or weight in the liver and right shoulder, and disturbance of digestion; but in some cases all these are absent. If the abscess be in the anterior part of the liver, its presence may be indicated by bulging, or enlargement with alteration of shape of the organ; but if deeply seated no indication of its presence may be found.

Treatment.—In the early stages the disease sometimes seems to be checked by the administration of large doses of ipecacuanha and the application of poultices or hot fomentations; and even when an abscess is present it may subside spontaneously, or may discharge through lung, stomach, bowels, or skin with a favourable result. Such cases, however, are exceptional; and the introduction of the aspirator and of antiseptic methods has shown that surgical interference in such cases need not be dreaded as it once was. Evacuation and opening of liver abscesses have in fact in recent years saved many lives that would otherwise in all probability have been sacrificed.

Acute yellow atrophy of the liver is a curious and happily rare disease, chiefly affecting young women, in which rapid and intense jaundice, attended by

severe nervous symptoms (headache, delirium, coma, &c.), but without fever, almost invariably leads to a fatal issue in a few days. After death the liver is found much diminished in size; and its secreting cells are reduced to a mass of oily debris. The symptoms much resemble those of phosphorus poisoning; but the causes of the disease are as yet obscure.

Cirrhosis of the liver, or interstitial hepatitis (Gr. *kirrhos*, 'yellowish'), begins as an inflammatory affection, in which lymph (see INFLAMMATION) is effused in the areolar tissue surrounding the branches of the portal vein. The smaller branches become obliterated by the pressure, and, as the lymph subsequently contracts, larger branches of the veins and ducts become strangulated, and the surface of the organ assumes the uneven or bossed appearance known as *lobulated*. In this affection the liver is probably at first somewhat enlarged, and occasionally remains so, but in general as the contraction of the effusion goes on it at length becomes considerably smaller than the natural size. The ordinary cause of this disease is spirit-drinking, and it is popularly known as the *gin-drinker's liver*. The obstruction to the portal circulation occasions the effusion of serum into the peritoneal cavity; and this effusion often goes on so rapidly as soon to force up the diaphragm and impede respiration. The lower extremities may become anasarous, but the arms and face are never affected. The portal obstruction often also gives rise to hemorrhage from the bowels or stomach. In a fully developed case of cirrhosis the liver is so altered in structure that palliative treatment is all that can be attempted. This must be directed to the relief of the dropsy, and, if medicines fail to remove or diminish it, temporary relief may be obtained by tapping; but the disease is a very hopeless one.

Amongst the other affections of this organ are the *fatty liver*. The liver in this case is much enlarged, of a pale colour, and rounded at the edges; the disease is most commonly found associated with phthisis and in cases of general obesity. Closely allied to this is the *lardaceous* or *waxy liver* (see WAXY DISEASE). Tubercle, syphilitic disease, and different forms of cancer, generally secondary to cancer elsewhere, are not unfrequently found in this organ. It is also much the most frequent seat of Hydatids (q.v.).

Liverpool, situated on the north bank of the Mersey, in Lancashire, is—if we include Birkenhead, on the opposite side of the river—the second largest town in the United Kingdom. A port not only for the adjacent manufacturing districts, but for the commerce with America, it ranks in maritime importance before the metropolis itself—a circumstance due to its position on the west coast of England. It is situated at three-quarters of an hour's distance by railway from Manchester (31 miles), four and a quarter hours from London (291 miles), six hours from Edinburgh (220 miles), and seven hours by rail and steamer from Dublin. The rise of Liverpool is remarkable. In the middle of the 14th century it contained only 840 inhabitants and 168 cottages; whilst in 1561 its population was only 690. This decadence accounts for the circumstance that though the town was represented in parliament in 1296 and 1306, there were no members summoned between the last named date and 1547. It is interesting to note here that Francis Bacon (afterwards Lord Chancellor) was M.P. for Liverpool in the years 1588-92. It was not until 1647 that Liverpool was made a free port (having been subject down to that date to the Chester officers); and it was not erected into a separate parish until 1697, when its population numbered about 5000 souls, and its shipping about 80 vessels. Between

1710 and 1760 its population increased from 8160 to 25,780, and its commercial navy from 84 vessels to 1245. In 1700 its first regular dock was built on the site where the custom-house stands at the present day. From 1760 to 1800 the population advanced from 25,700 to 77,700 inhabitants, the shipping from 1200 vessels to 5000, and the amount of dock-dues collected from £2300 to £28,300, nearly two-thirds of the increase taking place during the last fifteen years of the period. The chief cause of this extraordinary progress was the rapid growth of the cotton industry; the consumption of raw cotton having risen from 5,000,000 lb. in 1781 to 48,000,000 lb. in 1801; while the official value of cotton products exported had, in the meantime, increased from £355,000 to £7,051,000. Simultaneously with the mechanical revolution brought about by Hargreaves, Arkwright, Crompton, and others, there came an increased foreign trade, and an augmented inland business, owing to the opening of the Bridgewater (q.v.) Canal in 1771. About the same period, too, a great start was given to the shipbuilding trade of the port by several extensive orders received from government; some 15 vessels of war being launched between 1777 and 1782, of very considerable tonnage, and ranging between 16 and 50 guns. Liverpool as the leading port connected with the African trade, almost monopolised the traffic in slaves between Africa and the West Indies, &c. As late as 1807 her shipowners had 185 vessels engaged in the business, capable of carrying about 44,000 slaves. By the close of the last century Liverpool had far outstripped Bristol in commercial importance.

But great as was the progress made during the closing twenty years of the 18th century, it was far exceeded in the 19th; in 1881 the population within the municipal boundary was 552,508, and within the parliamentary boundary 601,950. In the next decade there was however an apparent decrease, the population of the city at the census of 1891, after some readjustment of areas, was 517,951, and of the parliamentary borough, 584,471. Adding to this the population of Birkenhead (q.v.), on the opposite side of the river, we get 684,328; so that, with other adjoining places, the total population of what may be termed the port of Liverpool is about 700,000. A very large number of merchants, brokers, tradesmen, clerks, and working-men, whose daily occupations are in Liverpool, have their residences on the Cheshire side of the river. The passenger traffic between the two sides of the river averages 60,000 per day, of which 44,000 are by the various ferries and 25,000 through the Mersey railway tunnel. The progress in population and tonnage compares as follows:

	Population			Shipping, Tons.	Dock Dues, £.
	Liverpool, No.	Birkenhead, No.	Total		
1781	30,000	1,500	40,500	200,000	5,000
1801	85,500	3,100	88,600	450,700	28,200
1821	144,700	4,700	149,400	830,800	94,500
1841	311,700	21,000	332,700	2,425,100	175,500
1861	477,000	73,000	550,000	4,897,200	144,400
1881	686,400	103,100	789,500	7,893,000	705,000
1891	517,951	170,000	687,951	9,775,500	1,117,900

The figures include the suburbs of both places. Of the entire population it is estimated that 150,000 are Irish and about the same number Welsh.

The effect of the Manchester Ship Canal on the trade of Liverpool has not been so injurious as was at one time expected. It does not follow that what Manchester secures Liverpool loses; and the more economical management of the Dock Estate, and the reduced railway charges which the competition of the canal enforces, may in the long run actually bring more business to Liverpool.

In 1891 the total tonnage of ships that entered and cleared at Liverpool (excluding coastwise sail

ings) was 10,489,578, as compared with 14,433,580 at London, and 10,478,391 at Cardiff. The imports of colonial and foreign merchandise at Liverpool show a value of £95,630,489; the exports of home produce to foreign ports, £78,089,359, and of foreign and colonial produce, £1,254,037. The whole foreign trade of Liverpool in 1895 was £186,259,875, as compared with a total at London of £224,718,326; all other ports dividing amongst them the remaining 40 per cent. of the trade of the whole country. Liverpool accounts for about one-fifth of the British tonnage, one-tenth of the foreign, and one-sixth of the total, and only falls behind London in respect of the foreign. Liverpool figures for one-fourth of the imports, more than two-fifths of the exports, and nearly one-third of the entire foreign trade of the United Kingdom. Of 115 million cwt. of bread-stuffs imported, 28 million came through Liverpool; as did also 3½ million out of 6 million cwt. of bacon, hams, beef, pork, and lard; 3 million out of 6 million cwt. of rice; 6½ million out of 17½ million cwt. of unrefined sugar; and 23 million out of 46 million lb. tobacco. Liverpool shipped £46,342,000 out of £71,986,000 worth of cotton products exported; £9,232,000 out of £25,006,000 worth of woollens; £2,942,000 out of £5,552,000 worth of linens; £11,705,000 out of £30,866,000 worth of metals; £4,502,000 out of £12,939,000 worth of machinery; and £1,489,000 out of £3,168,000 worth of hardware and cutlery.

This gigantic trade has given rise to the magnificent system of docks extending along the margin of the river for a distance of nearly 6½ miles, containing 25 miles of quay-space and 380 acres of water-space, besides 9 miles of quay-space and 164 acres of water-space at Birkenhead, making a total of 34 miles and 544 acres respectively. There are also 17 acres of water-space in the docks worked by the various canal companies, and there are besides 14,920 feet of graving-docks, of which 2430 feet are in Birkenhead. The total area of the Dock Estate is 1083 acres in Liverpool and 506 acres in Birkenhead. The whole of the docks (except the Salthouse, King's, and part of the George's and Queen's) have been built since 1812, and are regarded as amongst the greatest engineering triumphs of the 19th century. Several of the docks are enclosed with large warehouses: the erection of those round the Albert Dock cost £358,000. The dock itself cost £141,000. The warehouses round the Waterloo Dock contain large grain-elevators, which are a wonder in themselves. For the accommodation of the river traffic (passenger, goods, and mails) there is a floating landing stage, 2063 feet long and 80 feet wide, with seven large bridges connecting it with the shore; also a floating bridge, 550 feet long and 35 feet wide, by means of which an easy incline for carriage traffic is maintained at all stages of the tide. The steamer traffic, conducted by regular liners with every port of importance in the world, draws large numbers of emigrant and other passengers to the town. The total amount of capital invested in the Dock Estate is £17,088,683. See the article Dock.

Of the seven railways in direct connection with the city, the North Western, Lancashire and Yorkshire, and Midland have handsome passenger stations, and numerous goods stations are spread over the town and on the line of docks. There are five tunnels under the town. The Mersey railway tunnel, 1230 yards long, connecting Liverpool with Birkenhead, was begun in 1881, and opened by the Prince of Wales in 1886. The capital invested in the Mersey Railway amounts to £2,224,000. Number of passengers in 1890, 9,318,235. Prior to 1857 the water-supply of the town was derived

chiefly from the works at Bootle and Harrington. In 1850 steps were taken to erect the works at Revington (near Bolton), which were opened in 1857. In 1881 the foundation of new water-works was laid at Lake Vyrnwy, about 25 miles from Oswestry and 45 miles in a straight line from Liverpool. Liverpool has several extensive ship-building yards, iron and brass foundries, chain-cable and anchor smithies, engine works, tar and turpentine distilleries, rice and flour mills, tobacco, cigar, and soap manufactories, breweries, sugar-refineries, roperies, glass-works, chronometer and watch manufactories.

The architecture of the town has been greatly improved in the latter half of the 19th century, and it now possesses many fine thoroughfares, thronged with numerous splendid edifices. The domed Town-hall, in the Corinthian style, was originally built in 1754, but has since been considerably enlarged. St George's Hall is a grand building in the Greco-Roman style, nearly 500 feet long, built between 1838 and 1854. It comprises the assize court, a great hall 169 feet in length, 87 feet in width, and 74 to 82 feet high; and a smaller concert-room. The organ in the great hall cost £10,000, and the entire building £330,000. Municipal Offices, Custom-house, Sailors' Home, Police-courts, Workhouses, Baths and Wash-houses, Water-works, and Gas-offices are also noteworthy. The Free Library and Museum, opened in 1860, and presented to the town by Sir William Brown, cost £40,000; with it are incorporated the Museum of Natural History presented by the thirteenth Earl of Derby, and the Museum of Antiquities presented by Mr Mayer. Other institutions are the Walker Art Gallery, presented by Sir A. B. Walker, Bart., at a cost of £35,000; the Pieton Reading-room, erected by the corporation at a cost of £25,000; the Botanic Gardens, Observatory, the Liverpool College, Liverpool Institute, Queen's College, Medical Institute, Royal Institution, the various schools attached to the national and other churches, Academy of Fine Arts, the Exchange, Lyceum, and Athenæum, news rooms and libraries, and numerous associations devoted to commercial, political, philosophical, scientific, and religious affairs. University College, on the model of Owens College, was inaugurated in 1882; the endowment is over £125,000. The college, affiliated to the Victoria University, Manchester (see OWENS COLLEGE), had, in 1890, sixteen professors and lecturers in the literature and science department, and fourteen chairs in the medical department. There are about one hundred charitable institutions in the city. There are some 270 churches and chapels, of which 92 belong to the Established Church, 29 to Roman Catholics, 25 to Welsh Nonconformists, 24 to Presbyterians, 21 to Wesleyans, 18 to Methodists, 17 to Baptists, 14 to Independents, and 30 to various bodies, including 6 Unitarian chapels, 3 synagogues, a Friends' meeting-house, and a Greek church. The see of Liverpool was created in 1880, with an endowment of £100,000, raised by public subscription. There are seven cemeteries, only one of which is situated within the city.

The buildings devoted to commercial pursuits are also very fine and numerous. Amongst them are the Exchange, Liverpool and London Insurance Chambers, Royal Insurance, and Queen Insurance buildings (all local companies), and many others. The Exchange was originally built in 1803 S, but was rebuilt and enlarged in 1864-67. The cost of the new building, which stands upon about two acres of ground, was about £600,000. The general merchants and brokers, shipowners and brokers, metal merchants and brokers, wool brokers, leather brokers, &c. meet daily in the

news-room—175 feet long, 90 feet wide, and 50 feet high. The cotton merchants and brokers meet (according to the custom of nearly a century) in the open air, in the spacious area or 'flags.' The style of the building is French Renaissance. Of clubs there are the Reform, Junior Reform, Conservative, Palatine, Exchange, &c. There are fourteen banks in the town, and several of them are possessed of very large and handsome business premises. Amongst these may be named the branch of the Bank of England, and the Liverpool, Union, North-Western, Parr's, District, Commercial, National Provincial, and North and South Wales banks. Of monuments the chief are those of the Queen, Prince Albert, William IV., Nelson, Wellington, Huskisson, and Beaconsfield, besides several in the Town-hall, St George's Hall, Free Library, and parks. The parks are eight in number—the Stanley, Sefton, Prince's, Botanic, Kensington, Newsham, Sheil, and Wavertree.

The market-days are Wednesday and Saturday, for general agricultural produce, and Tuesday and Friday for corn. The fairs for horses and cattle are held July 25th and November 11th. The corn trade transacts its business in the Corn Exchange, Brunswick Street, and there is an extensive market for the cattle-dealers in Kensington. For agricultural produce there is the Northern Hay Market. For edibles of all kinds there are St John's, and St James's, Gill Street, and St Martin's markets. There are six daily (four morning and two evening) and four weekly newspapers, besides the *Daily Telegraph* and *Bill of Entry*, exclusively devoted to shipping matters, three weekly literary periodicals, and one scientific monthly magazine. Since 1885 Liverpool returns nine members to parliament.

The name *Liverpool* first occurs in a deed of 1190: the etymology is not improbably the *Cymric Llyrpool*, 'the expanse at the pool,' or 'the pool at the confluence.' The Derby (Stanley) and Sefton (Molynex) families, whose mansions are only a short distance from the town, have from the earliest times been intimately connected with the borough and city. Several members of both families served the office of mayor in the 16th, 17th, and 18th centuries. Amongst other worthies, natives of the town, may be mentioned Jeremiah Horrocks, the eminent astronomer; George Stubbs, eminent as an animal painter; John Deare, sculptor; John Sadler, inventor of painting on pottery; Peter Letherland, inventor of the patent lever watch; Mis Hemans, the poetess; Benjamin Spence, sculptor; and William Roscoe, poet, historian, and banker. Other 'Liverpudlians' of eminence in various departments of life were Viscount Cardwell, Bishop Lightfoot, General Earle, Mr Gladstone, Sir James Pictou, A. H. Clough, Meadows Taylor, the actor Sothorn, Ansdell, Gunter, Waterhouse, A. W. Hunt, Walter Crane, W. S. Jevons, and the new 'Liverpool school'—a term held to comprise J. A. Noble, William Watson, Hall Caine, R. Le Gallienne, and others.

See Baines, *History of the Commerce and Town of Liverpool* (1852); Pictou, *Memorial of Liverpool* (2 vols. 1874; 2d ed. 1876); and *The Cotton Trade of Great Britain, with a History of the Liverpool Cotton Market*, by the writer of the present article (1886).

Liverpool. ROBERT BANKS JENKINSON, EARL OF, statesman, was born 7th June 1770, the son of the first Earl (1727-1808). He was educated at the Charterhouse and Christ Church, Oxford, and entered parliament in 1791 as member for Rye. Like his father he was a Tory, but with Liberal ideas on trade and finance. In 1794 he became a member of the India Board, and in 1801 foreign secretary in the Addington ministry, when he

negotiated the unpopular treaty of Amiens. In 1803 he was created Lord Hawkesbury, and on Pitt's return to power he went to the Home Office, as it was thought desirable he should continue to lead the House of Lords. On the death of Pitt he was invited to form an administration, but declined in consequence of the schism in the Tory party. In 1807, however, he again took the Home Office, under the Duke of Portland, and next year succeeded his father as Earl of Liverpool. In Perceval's ministry of 1809 he was Secretary for War and the Colonies, and in this capacity was charged with pusillanimity in connection with the Peninsular war. After the assassination of Perceval in 1812 Lord Liverpool formed an administration which it was predicted would not last for six months, but which in fact existed for nearly fifteen years, and then fell only through the illness of the premier himself. The first ten years of the Liverpool ministry (1812-22) have been severely criticised. The partition of Saxony, the abandonment of Poland, the union of Holland and Belgium, the Austrian establishment in Italy, the alleged connivance of England in the suppression of the revolutionary agitation in Naples, the mismanagement of the finances, the increase in the duty on foreign corn, the coercive measures adopted for dealing with discontent in England, are all pointed to as so many proofs of the incapacity or despotic sympathies of the English government of this period. Lord Liverpool himself was a Free Trader, and regarded the Corn Law of 1815 as merely an experiment; and when he was joined by Huskisson and Canning he began to liberalise the tariff. He also desired to retain a portion of the property tax, which would have obviated the necessity for fresh taxes; and, as it only affected men with incomes of upwards of £200 per annum, its retention would have been a distinct boon to the working-classes. But Whigs and Tories alike opposed it. Notwithstanding the blunder of the sinking fund, Lord Liverpool's financial policy generally was of a sound and enlightened character; and his administration was an economical one. As a statesman, his chief title to remembrance lies in the fact that he united the old and the new Tories at a critical period, and in a manner which neither Canning nor Wellington could accomplish. On February 17, 1827, he was stricken with apoplexy, but he remained nominally prime-minister until April, when Canning formed a new government. He died 4th December 1828. See the Life by C. D. Yonge (3 vols. 1868).

Liver-rot. See FLUKE.

Liverworts (*Hepatica*) are green flowerless plants closely allied to mosses. They grow profusely on damp rocks, not infrequently on leaves and stems in moist tropical regions, and sometimes even in the water. The majority are prostrate creepers, but others raise themselves in upright leafy growths, intermediate between the wholly leaf-like Thallophytes (e.g. seaweeds) and the higher Cormophytes (e.g. fern) in which distinct stem structures are developed. There is a marked difference in structure between the upper and lower surfaces; thus, the former turned towards the light bears chimney-like openings (*stomatia*), while the under side next the substratum gives off attaching and absorbing micellular outgrowths (*rhizoids*) which are physiologically comparable to the roots of higher plants. If a young plant floating in water be illumined wholly from beneath, the rhizoids will develop on the upper surface, i.e. away from the light as usual. The growth is usually forked or dichotomous, and is often remarkably profuse by the moist river side or in the damp greenhouse. The plants die away behind

as they push ahead with fresh growth, and apart from this they multiply asexually by means of detachable clumps of cells (or *gemmae*), which are often formed in special cups on the upper surface.



Life-history of Livery (1. *Marchantia polymorpha*): 1 and 2, developing thallus; 2 shows the cup with gemmae; 3, section of a cross thallus, showing chimney-shaped stomata and reproductive cells under, and nomenclature cell on left; 4, male hats; 5, development of antheridia; 6, antheridium nearly ripe; 7, antheridium; 8, female hat; 9, 10, archegonia before fertilisation; 11, 12, 13, fertilised egg dividing; 14, immature sporogonium, containing spores and elaters.

Like the Hydra among animals, liverworts may be artificially propagated by being cut into fragments, and they have remarkable powers of surviving prolonged desiccation.

On the vegetative thallus male and female hats or reproductive organs are borne, on the same or on different plants, often with a quaint umbrella-like or mushroom-like form. From a female cell fertilised by an actively motile male element there arises a new spore-bearing generation, but this, as in mosses, remains connected with the sexual plant. Within the spore-cases of the spore-producing generation there are long spring-like cells (*elaters*), which twist and untwist as moisture is absorbed or given off, and in so doing help to scatter the ripe spores. From the latter the new liverworts are established, the life-history thus illustrating the usual alternation of generations between oophyte and sporophyte. The class Hepaticae includes five orders: (1) Jungermanniaceae—e.g. *Jungermannia* and *Pellia*; (2) Monocleaceae—e.g. *Monoclea*; (3) Anthocerotaceae—e.g. *Anthoceros*; (4) Ricciaceae—e.g. *Riccia* and *Riccia*—the latter remarkable for its submerged bat-crest thallus, which forms a continuous spiral round a central axis; (5) *Marchantia*—e.g. *Marchantia*, *Lunularia*, and *Fegatella*. The abundant *Marchantia polymorpha* is a convenient type for the practical study of the class. See Bennett and Murray, *Handbook of Cryptogamic Botany* (Lond., 1889).

Livery (through the French from Lat. *liberari*, 'to deliver'), a word derived from the custom which prevailed under the Merovingian and Carolingian kings of *delivering* splendid habits to the members of their households on great festivals. In the days of chivalry the wearing of livery was not as now confined to domestic servants. The duke's son, as page to the prince, wore the prince's livery, the earl's son bore the duke's colours and badge, the son of the esquire wore the livery of the knight, and the son of the gentleman that of the esquire. Cavaliers wore the livery of their mistresses. There was also a large class of armed retainers in livery attached to many of the more powerful nobles. The livery colours of a family are taken from their armorial bearings, being generally the tincture of the field and that of the principal charge, or the two tinctures of the field are taken instead where it has two. They are taken from the first quarter in case of a quartered

shield. These same colours are alternated in the 'wreath' on which the crest stands. The royal family of England have sometimes adopted colours varying from the tinctures of the arms. The Plantagenets had scarlet and white; the House of York, murrey and blue; white and blue were adopted by the House of Lancaster; white and green by the Tudors; yellow and red by the Stuarts, and by William III.; and scarlet and blue by the House of Hanover. An indispensable part of the livery in former times was the Badge (q.v.).

The freemen of the 75 city guilds or corporations which embrace the different trades of London are called liverymen, because entitled to wear the livery of their respective companies. In former times the wardens of the companies used yearly to deliver to the Lord Mayor certain sums, twenty shillings of which was given to individuals who petitioned for the money to enable them to procure sufficient cloth for a suit, and the companies prided themselves on the splendid appearance which their liveries made in the civic train. Till the Reform Bill in 1832, the liverymen had the exclusive privilege of voting for members of parliament for the City. The twelve chief corporations are the Mercers, Grocers, Drapers, Fishmongers, Goldsmiths, Skinners, Merchant Tailors, Haberdashers, Salters, Ironmongers, Vintners, and Clothworkers. A royal commission was appointed to inquire into the City companies in 1880, when their charitable or trust income was returned at £200,000 a year, their corporate income at upwards of £550,000, and the capital value of their property (in the City, in the funds, in estates all over England and in Ulster) at £15,000,000. The annual cost of the hospitality exercised by the companies was estimated at £100,000; and of the 20,000 hereditary members about 12,000 were said to belong to the working-classes. The commission's gigantic Report was issued in 1884.

Livingston. See GUATEMALA.

Livingston, an eminent American family, descended lineally from the fifth Lord Livingston, the guardian of Mary Queen of Scots, and from his grandson, the Rev. John Livingston (1603-72), minister of Anerum in Teviotdale, who was banished for refusal to take the oath of allegiance to Charles II., and from 1663 was pastor of the Scots kirk at Rotterdam. His son Robert was born at Anerum in 1654, went to America in 1673, settled at Albany, and received a grant of a vast tract of land, which he had erected into the manor and lordship of Livingston. He died in 1725. One of his grandsons was Philip Livingston (1716-78), who sat in the first Continental congress, and was one of the signers of the Declaration of Independence. Another was William Livingston (1723-90), the 'Don Quixote of the Jerseys,' who was the first governor of New Jersey (1776-90), and conspicuous for the energy and ability of his administration. The most distinguished of the family, however, were the brothers Robert R. and Edward Livingston, great grandsons of the first Robert.

ROBERT R. LIVINGSTON was born in New York city, 27th November 1746, graduated at King's (now Columbia) College in 1765, and was admitted to the bar in 1773. Sent to congress in 1775, he was one of the five members of the committee charged with drawing up the Declaration of Independence. When the constitution of the state of New York was settled he was appointed chancellor, a dignity he retained till 1801. He was then sent to Paris as minister plenipotentiary, and successfully negotiated the cession of Louisiana to the United States. He enabled Fulton to construct his first steamer, and introduced in America the

use of sulphate of lime as a manure, and the merino sheep, and in many other ways distinguished himself as a national benefactor. He died on 26th February 1813. There is a biography by F. De Peyster (New York, 1876).

EDWARD LIVINGSTON, jurist and statesman, was born at Clermont, New York, 26th May 1761, and graduated at Princeton in 1781. He was called to the bar in 1785, and soon obtained an extensive practice. He had spent his youth among the founders of American independence, all of whom he had known as visitors of his father—a justice of the New York Supreme Court—and he at once attained a prominent position. He sat in congress from 1795 to 1801, when he became U.S. district attorney for New York, and mayor of New York city; but in 1803, owing to the misappropriations of a subordinate, he found himself considerably in debt to the federal government. He at once handed over his whole property to his creditors, threw up both his appointments, and resolved to quit New York. Louisiana had just been annexed to the United States through his brother's negotiations; and in 1804 he settled in New Orleans, where he at once obtained lucrative practice at the bar. During the second war with England he was aide-de-camp and secretary to General Jackson; and from 1822 to 1829 he represented New Orleans in congress. In 1823-24 Livingston was employed in reducing to system the civil code of Louisiana—for which task his wide acquaintance with jurisprudence rendered him peculiarly fitted. He was also commissioned to prepare a new criminal code, and in a preliminary treatise he laid down the principles on which he was to proceed. He proposed the abolition of the punishment of death, and a penitentiary system, which at once drew general attention to his labours. His book was reprinted in London, translated into French, and was very favourably received in England, France, and Germany. His code of crimes and punishments was completed, but not directly adopted. Livingston was elected in 1829 to the United States senate, and in 1831 appointed secretary of state. Two years later he went to France as minister plenipotentiary, and succeeded in securing payment of the indemnity on account of French spoliations. He died on 23d May 1836. See the Life by C. H. Hunt (New York, 1864).

Livingstone, DAVID, missionary and traveller, was born at Blantyre in Lanarkshire, 19th March 1813. His parents, who were in humble life, were of devout and exemplary character; his father in particular being a great reader, especially of travels and missionary intelligence, and much interested in the enterprise of the 19th century. At the age of ten David became a worker in a cotton-factory at Blantyre, and continued in that laborious occupation for fourteen years. His thirst for knowledge led him to read all that he could lay his hands on; he used also to attend a night class, after the long hours of the factory, for the study of Latin. The reading of Dick's *Philosophy of a Future State* was not only the means of a profound impression on his own mind, but kindled the desire to devote his life as a missionary to the service of Christ. Deeply impressed with the advantages of medical training to a missionary, he resolved to qualify himself in medicine, as well as the other attainments looked for in a missionary. The London Missionary Society having accepted the offer of his services, he went to London to complete his studies. His first desire was to labour in China, but, war having broken out between that country and Great Britain, this wish could not be fulfilled. The Rev. Robert Moffat's visit at this time to England turned many hearts to Africa—Livingstone's among the rest; ultimately he was

appointed to that field, and, having been ordained on 20th November 1819, he set sail for Africa, reaching Lattakoo or Kuruman, Moffat's settlement, on 31st July 1841.

For several years Livingstone laboured as a missionary in the Bechmana country, at Mabotse, Chomana, and Kolobong, places that were chosen by him just because they were in the heart of heathenism. The conversion of Sechele, chief of the Bakwains, and several of his tribe was a great encouragement. Repulsed by the Boers in an effort to plant native missionaries in the Transvaal, he directed his steps northward, discovered Lake Ngami, and found the country there traversed by fine rivers and inhabited by a dense population. His anxiety to benefit this region led finally to his undertaking to explore the whole country westwards to the Atlantic at St Paul de Loanda and eastward to the Indian Ocean at Quilimane. Livingstone had married at Mabotse Mary, eldest daughter of the Rev. R. Moffat, and now he found it necessary to send her, with their children, to England, that he might be free for this vast and perilous undertaking. To accomplish it occupied from 8th June 1852, when he left Capetown, to 26th May 1856, when he arrived at Quilimane. This journey was accomplished with a mere handful of followers, and a mere pittance of stores, amid sicknesses and other bodily troubles, perils, and difficulties without number. But a vast amount of valuable information was gathered respecting the country and its products, its geography and natural history, the native tribes, the regions that were favourable to health, and some great natural wonders, such as the Zambesi Falls. Livingstone, however, found that the London Missionary Society were not willing that he should be to so large an extent an explorer, and some time after returning to Britain he resigned his office as one of their missionaries.

At home Livingstone was welcomed with extraordinary enthusiasm, receiving the acknowledgments and honours of scientific societies, universities, town-councils, and other public bodies in every quarter of the country. In addition to these tokens of honour the fifteen months spent at home were signalised by three things: the writing of his book, *Missionary Travels* (1857), which was received with the liveliest interest; his visit to Cambridge, awakening the enthusiasm of many of the students, and leading to the formation afterwards of the 'Universities Mission'; and his appointment by Her Majesty's government as chief of an expedition for exploring the Zambesi and its tributaries and the regions adjacent.

On this expedition Livingstone set out on 10th March 1858. While successful in many ways, it led to not a little disappointment. Livingstone explored the Zambesi, the Shire, and the Rovuma; discovered lakes Shirwa and Nyassa, and came to a decided conclusion that Lake Nyassa and its neighbourhood was the best field for both commercial and missionary operations. His disappointments arose from the grievous defects of a steamer sent out to him by government; from the death of comrades and helpers, including his wife and Bishop Mackenzie; from the abandonment of the Universities Mission; from the opposition of the Portuguese authorities; but mainly from the distressing discovery that, encouraged by Portuguese traders, the slave-trade was extending in the district, and the slave-traders using his very discoveries to facilitate their infamous traffic. At length a despatch recalling the expedition was received, 2d July 1863. Livingstone at his own cost had brought out a new steamer, but she could not be put on the lake. Depressed though he was, he explored the northern banks of Lake

Nyassa on foot; then in his own vessel and under his own seamanship crossed the Indian Ocean to Bombay; and after a brief stay there, returned to Britain, reaching London on 23d July 1864.

At home Livingstone had two objects—to expose the atrocious deeds of the Portuguese slave-traders, and to find means of establishing a settlement for missions and commerce somewhere near the head of the Rovuma, or wherever a suitable locality could be found. His second book, *The Zambesi and its Tributaries* (1865), was designed to further these objects. He was again received with every demonstration of honour and regard. A proposal was made to him on the part of the Royal Geographical Society to return to Africa and settle a disputed question regarding the watershed of central Africa and the sources of the Nile. He said he would go only as a missionary, but was willing to help to solve the geographical problem. He set out in August 1865, *via* Bombay and Zanzibar. On 19th March 1866 he started from the latter place, first of all trying to find a suitable settlement, then striking westward in order to solve the geographical problem. Through the ill-behaviour of some of his attendants a report of his death was circulated, but an expedition headed by Mr E. D. Young, R.N., ascertained that the report was false. Livingstone pressed westward amid innumerable hardships, and in 1869 discovered Lakes Mooro and Bangweolo. All the while he was doing what he could for the religious enlightenment of the natives. Obligated to return for rest to Ujiji, where he found his goods squandered, he struck westward again as far as the river Luabala, thinking it might possibly be the Nile, but far from certain that it was not what it proved afterwards to be, the Congo. Returning after severe illness once more to Ujiji, Livingstone found Mr H. M. Stanley there, who had been sent to look for him by the proprietor of the *New York Herald*. But no consideration would induce him to return home till he had made one more effort to solve the geographical problem. He returned to Lake Bangweolo, but fell into wretched health. His sufferings always increasing, when he reached Chitambo's village in Ilala he was obliged to give in. On the morning of 1st May 1873 he was found by his attendants on his knees, dead. His faithful people embalmed his body as best they could, carried it amidst the greatest perils to the shore, where it was put on board a British cruiser, and on 18th April 1874 it was buried in Westminster Abbey. Among the remains brought home were his *Last Journals*, brought down to within a few days of his death; these were published in 1874. Stanley suggested the name of Livingstone for the main stream of the Congo (hence the Baptist Mission on the Lower Congo was called the 'Livingstone Inland Mission'), and Mr H. H. Johnston proposed that part of the East African territory acquired by Britain in 1890—the lower drainage area of the Zambesi—should be called Livingstone Land.

See Professor Blakie's *Personal Life of David Livingstone* (1880); the short *Life* by Thomas Hughes (1889); and Sir H. H. Johnston, *Livingstone and the Exploration of Central Africa* (1891).

Livingstonia Mission was based on a suggestion made by Dr Livingstone that Lake Nyassa (q.v.) was the best position for the establishment of a mission with a view to the annihilation of the Portuguese and Arab slave trade on the east of Africa. Its first settlement was at Cape Maclear at the south end of the lake; but this was abandoned in 1883 for a healthier site at Bandawe, half-way up the west shore. An expedition, costing about £6000, was equipped in 1875 by the Free Church of Scotland for establishing the

mission here; and another station, called Blantyre, after Livingstone's birthplace, was planted in 1876 by the Established Church of Scotland in the Shire Highlands, within easy distance of the lake. As yet the chief industries are iron manufacture, basket-making, and cloth manufacture from the bark of trees and cotton. With the exception of the 70 miles of the Murchison Falls, there exists unbroken water-communication between the head of Nyassa and the Indian Ocean. The African Lakes Company has done much to promote missions, civilisation, and commerce. It blasted a road from the north end of Nyassa up the heights to the plateau between it and Tanganyika, at a cost of £4000, supplied by Mr Stevenson, after whom the road is named. It launched steamers, educated the natives in handicrafts, and had to stand the brunt of attacks from savage neighbours, Arab slave traders, and Portuguese hostility. But since 1890 the country is under the British flag, and is part of Nyassaland (see NYASSA) or British Central Africa.

Livius. See LIVY.

Livius Andronicus, the father of Roman dramatic and epic poetry, was a Greek by birth, probably a native of Tarentum, and was carried a slave to Rome in 272 B.C., but afterwards liberated by his master. He translated the *Odyssey* into Latin Saturnian verse, and wrote tragedies, comedies, and hymns after Greek models. Mere fragments are extant, collected in L. Müller's *Livii Andronicæ et Cæ. Nævi Fabularum Reliquiæ* (1885). See LATIN.

Livonia (Ger. *Litland*), one of the three Baltic provinces of Russia, to which belong also the islands of Oesel, Mohl, and Kuno, contains an area of 18,153 sq. m. It forms the eastern side of the Gulf of Riga, and lies between Esthonia on the north and Courland on the south, being separated from this latter by the river Dwina. The country is mostly flat, and nearly one-fourth of it is covered with forests. Lakes and streams and marshes are common. The soil is only of moderate fertility; nevertheless agriculture, the chief occupation, is carried on in a skilful manner, rye, barley, oats, flax, and potatoes being the principal crops. Distilling, brewing, iron-founding, oil-pressing, and cork, wool, and paper manufacture are the more important industries. Sawmills are active. The fisheries are valuable. Pop. (1870) 1,000,876; (1893) 1,270,530, of whom 43 per cent. are Letts, 41½ per cent. Esthonians, 8 per cent. Germans, and 5 per cent. Russians. The Livonians proper, a Finnic race akin to the Esthonians, have dwindled down to about 2400. Capital, Riga; other towns, Dorpat, Pernau, Wenden. In the first decade of the 13th century the principality was given to the Knights of the Order of the Sword, who in 1237 were merged in the order of the Teutonic Knights, and maintained their sovereignty against the Archbishop of Riga, and against Sweden, Poland, Lithuania, and Russia down to past the middle of the 16th century. From that time Livonia was a bone of contention between Poland, Sweden, and Russia, until its incorporation with the last-named country in 1721. Since the middle of the 19th century, and especially since 1881, the Russians have made determined efforts to 'russify' the province.

Livorno. See LEGHORN.

Livre, the name of an ancient French coin, derived from the Roman *Libra*. There were livres of different values, the most important being the *Livre Tournois* (of Tours), which was considered the standard, and the *Livre Parisis* (of Paris), which was equal to five-fourths of a livre Tournois. It was divided into 20 sous, each of 12 deniers. In

1795 the livre was superseded by the franc (80 francs = 81 livres Tournois). LIVRE was also the ancient French unit of weight, and was equal to about 1 lb. avoirdupois; the kilogramme (see GRAMME) has taken its place.

Livy. TITUS LIVIUS (59 B.C. 17 A.D.), Rome's greatest historian, was born, according to St. Jerome, at Patavium (now Padua) in the Venetian province, in Julius Caesar's first consulship. Of a noble and wealthy family, he received the usual education in rhetoric and philosophy, and on coming to Rome was admitted to the court of Augustus. Independent in character and means, he never flattered the emperor like Virgil and Horace, but, avowing his preference for the republic over the monarchy, he foresaw in the growth of luxury the fall of the empire, and in the loss of freedom the end of Rome. He praised Brutus and Cassius and sympathised with Pompey, at the same time stigmatising Cicero, an accessory to the murder of Caesar, as having got from Antony's bravo's only his deserts. Of the great Caesar himself he doubted whether he was more of a curse or a blessing to the commonwealth; and throughout his history he seems to have mentioned Augustus but twice, and that incidentally—though in reply to the Greek Timagenes, the detractor while the guest of Augustus, he says that by restoring peace and allaying civil strife the emperor had reinvigorated Rome to overcome a thousand armies more formidable than the Macedonian Alexander's. Such friendship as they had for each other Livy and Augustus never lost—Augustus taking a lively interest in the progress of Livy's work, while Livy seems to have been still intimate enough at court to exhort the future Emperor Claudius (born 10 B.C.) to the study of history. Livy had a son, also, it is believed, a man of letters, and a daughter married to Magnus the rhetorician. He visited various parts of Italy—among them Campania and the Neapolitan seaboard, and, probably in disgust at the abasement of the senate and the cruelties of Tiberius, he returned to his native Patavium to die.

Livy's work, recording the history of Rome from her foundation to the death of Drusus, 9 B.C., was published in instalments, and comprised 142 books, of which those from the 11th to the 20th, and from the 46th to the 142d, have been lost. Of the 35 that remain the 41st and 43d are imperfect. The last writer to notice the history as still entire is Priscian the grammarian (5th century). Its voluminousness, the labour and cost of transcription, and possibly the vindictive hatred of emperors, like Caligula, to its republican spirit, combined, it is supposed, to lessen the number of copies, till those that survived must have perished in whole or in part, with such pagan libraries as Gregory the Great is known to have burned. The hope, renewed at intervals, of recovering the lost books has never been realised; the 'periœche,' or summaries of the contents of each book, composed in the wane of Roman literature, to catalogue names and events for rhetorical purposes, have all, however, come down to us, except those of books 136 and 137. But what has been spared is more than enough to confirm in modern days the judgment of antiquity which places Livy in the forefront of Latin writers. His impartiality, subject always to a conviction just escaping Chauvinism that Rome morally and materially was the greatest 'birth of time,' is not less a note of his work than his veneration for the good, the generous, the heroic in man. His style, save where the text still defies the commentator, is as nearly perfect as is compatible with his ideal of the historian. The narrative flows deep and full, never straying beyond its banks nor growing turbid within them, picturesque on all due occasions,

interesting and animated through historic traits often dreary in themselves. Niebuhr found in his rich, at times sombre, glow of colour another proof of his Venetian origin; certainly for portraiture of character he is the Titan of historians. The fastidious, possibly jealous, Asinius Pollio detected in his Latinity a provincialism odious to Patavium, but latter-day scholars seek for this 'Patavinitas' in vain—find, in fact, nothing more than the first faint streaks of the silver age revealed in an occasional preference for poetic diction. His defects in the 'fierce light' of modern research are more apparent to us than even to his contemporaries. For investigation of facts he did not go far afield; our own Hume is not more of an arm-chair historian. He declined even at the instance of Augustus to verify an important inscription in the temple of Jupiter Feretrius, and he omitted to consult the epigraphs inscribed in the temple of Diana on the Aventine, the treaties concluded by Rome with Gabii and Aiden, even the Julian law which Dionysius examined with such pains. Accepting history as fine art rather than as science, he was content to take his authorities as he found them, and where they differed to act the eclectic, guided by taste or predilection. Yet his work remains monumental, in spite of all the streaks in the marble, and the modern reader never fails to appreciate that impulse of the Spaniard from Gades who made a pilgrimage to Rome just to see Livy, and having done so returned satisfied.

The bibliography accumulated round Livy is a library in itself. Gronovius, Drakenborch, Rudiman, and, in our own day, Matvig, Alsheiski, Weissenborn, and Cocchia have contributed much to purify his text and illustrate his meaning. He has yet to find an adequate translator in English, though meritorious versions of parts of his history (that of Church and Brodribb for example, Books XXI.—XXV.) have been published, and there is a translation of the whole, in fine Elizabethan English, by Philemon Holland (1600). See the book by the Rev. W. W. Capes in 'Classical Writers' 1879; J. H. Taine's *Essai sur Titus Live* (1860); and Prof. Seeley's introduction to his edition of Book i. (1871).

Lixiviation (Lat. *lix*, 'ashes'), a term employed in chemistry to denote the process of washing or steeping certain substances in a fluid, for the purpose of dissolving a portion of their ingredients, and so separating them from the insoluble residue. Thus, wood-ash is lixiviated with water to dissolve out the carbonates of soda and potash from the insoluble parts. The solution thus obtained is called a *lixivium*, or *lyx*.

Lixouri, a thriving town in Cephalonia, on the west side of the Gulf of Argostoli. It lies opposite the capital, Argostoli (q.v.), at a distance of less than 3 miles, though the road round the gulf is nearly 20 miles long. Pop. 8000.

Lizard Point. See CORNWALL.

Lizards (*Lacertilia*), an order of reptiles occupying a somewhat central position in that class. The body is usually well covered with scales, reaching a climax in the tubercles and spines covering the Australian molech, but very much reduced in the geckos and amphibienas. There are generally fore and hind limbs, but either pair may be lost, or both in such serpent-like forms as the slow worm (*Anguis fragilis*) and the amphibienas. Shoulder and hip girdles are always present, in rudiment at least. Unlike snakes, lizards have non-expandible mouths, and almost always movable eyelids and external ear-openings. The teeth are fixed to the jaws, not planted in sockets; the protrusible tongue, broad and short in geckos, agamas, and iguanas, long and terminally clubbed in chameleons, is in most lizards a narrow, worm-like, bifid organ of touch. There is a transverse cloacal aperture, a urinary bladder, and a double copulatory organ.

Most are oviparous, but a few—e.g. the slow-worm and our British *Lacerta vivipara*—bring forth their young living. Lizards, though most abundant in the tropics, and absent from very cold countries, are virtually world wide in distribution. There is one marine form, *Oroscoptes*; *Anolis* (class *opisthopterus*), from the Galapagos; most of the rest are terrestrial. Yet the geckos climb on rocks and trees, the giant Varanids are semi-aquatic, the amphibiaenas are subterranean, and the arboreal dragons (*Draco*) take long swoops through the air from branch to branch. The food generally consists of insects, worms, and similar small animals, but some prey upon larger animals, and others are vegetarian. Lizards are usually active, agile animals, beautifully and often protectively coloured. They are noteworthy for brittleness in the caudal region, and for their power of reproducing lost tails or even legs. Among the most remarkable forms may be noted the Geckos (q.v.); the large monitors (*Varanus*), which attain a length of six feet, and prey upon small mammals, birds, frogs, fishes, and eggs; the poisonous Mexican lizard, *Holbrookia horvathi*, with large poison-gland and fang-like teeth; the worm-like Amphibiaenas; the Slow worm, which illustrates so well the tendency lizards have to break in the spasms of capture; the large Iguanas, which frequent tropical American forests, and feed on leaves and fruit; the sluggish spiny 'Horned Toads' (*Phrynosoma*); the Agamas, taking the place of the Iguanas in the Old World; the Flying Dragon (q.v.); the Australian frilled lizard (*Chlamydosaurus*), with a peculiar collar of skin; the repulsive molech; and the divergent Chamaeleons (q.v.). The unique New Zealand lizard, *Sphenodon* or *Hatteria*, with its remarkable persistent pineal

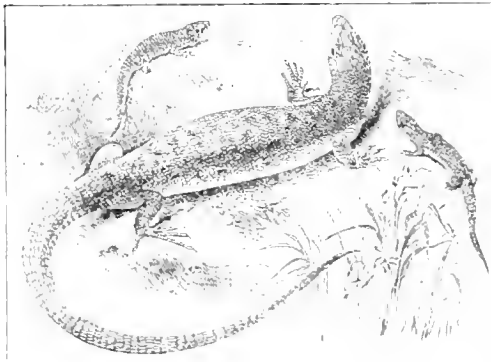

Common Lizard (*Lacerta vivipara*).

eye, is to be regarded as the sole survivor of a distinct order, *Rhynchocephalia* (see SPHENODON). There are four British lizards, the commonest being *Lacerta vivipara* and the Slow-worm. Two other species of *Lacerta*—*L. agilis* and the green *L. viridis*—have a local distribution in the south of England and the Channel Islands. The modern forms are classified in twenty-one families, including over 1600 species. Though *Lacertilla* probably began about the Permian times, their remains are not numerous before Tertiary strata. See G. A. Boulenger, Catalogue of the Lizards in the British Museum (3 vols. 1885-87).

Llama, or LAMA (*Lachania lama*), a most useful South American ruminant of the camel family. It is probably a domesticated variety of the guanaco (*Lachania guanaco*), whose herds roam with the rheas on the plains of Patagonia, or climb on the Cordilleras. As a beast of burden the llama was in general use at the time of the Spanish conquest, and its sure-footedness and power

of foraging for itself make it most valuable for transport in the rough and steep mining regions of the Andes. In many places, however, mules have to some extent replaced the llamas. The males carry a hundredweight about twelve miles in a day. The females, which are kept for breeding,

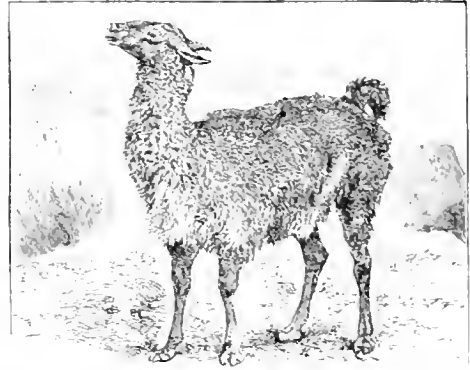

Llama (*Lachania lama*).

are smaller and less strong than the males. The animal is larger and stouter than the allied species the Alpaca (q.v.), stands about three feet high at the shoulders, and keeps its head raised. It is gentle and docile, but is likely enough to squirt its yellow spittle in the face of tormentors. The hair, which may be black or white, reddish or yellowish, is too rough to be much used except for coarse materials and string; the flesh of the young animal is good to eat.

Llanberis, the 'Chamonix of Wales,' 9 miles ESE. of Carnarvon, lies at the north-west base of Snowdon, and near the foot of the wild Pass of Llanberis. The two lakes of Llanberis, 2 and 14 miles long, are sadly disfigured by slate-quarries. Pop. of parish (1861) 1364; (1881) 3033; (1891) 2818.

Llandaff, a small town of Glamorganshire, on the right bank of the Taf, 2 miles NW. of Cardiff (q.v.). It is the seat of a very ancient bishopric, said to have been founded by St. Dubricius, who died in 612, and among whose successors have been St. Teilo and Bishops Godwin, Shute Barrington, Richard Watson, Sumner, and Copleston. The cathedral church, in virtue of which Llandaff is a 'city,' one of the smallest in Britain—was built between 1120 and the first half of the 15th century, and is mainly Early English in style. It had fallen into utter ruin in 1575, but in 1735-52 was barbarously patched up into an 'Italian temple.' In 1833-69 it was thoroughly restored. Pop. 2747. See works by E. A. Freeman (1850), Bishop Ollivant (1860), and R. J. King (1873).

Llandilo, a town of South Wales, on the Towy, 14 miles ENE. of Carmarthen. It gives name to a group of Silurian strata. Pop. 1533.

Llandovery, a municipal borough (1841) of South Wales, on the Bran, 25 miles ENE. of Carmarthen. It gives name to a group of Silurian strata. Pop. 1728.

Llandudno, a fashionable watering place in Carnarvonshire, North Wales, is situated on the level neck of a promontory between the Great and Little Orme's Heads, 48 miles by rail WNW. of Chester. Its bracing and delightful climate, its good sea-bathing, and its picturesque surroundings—the Great Orme's Head (700 feet) commanding views of Snowdon and Anglesey, and even of Man and the Cumber-land mountains—have combined to raise Llandudno since 1841 from a small fishing-village to a yearly resort of some 20,000 visitors,

with many hotels and boarding-houses, hydro-paths, a fine promenade, a pier (1250 feet), a 'marine drive' (5½ miles), &c. Resident pop. (1851) 1131; (1881) 4839; (1891) 6065.

Llanelli, a manufacturing town and seaport of Carmarthenshire, South Wales, 11 miles WNW. of Swansea. The mineral wealth of the vicinity, and the easy access to the sea, have raised it from a mere village in 1813 to a town of considerable commercial importance. The Cambrian copper-works employ a great number of the inhabitants; there are also silver, lead, iron, and tin works, potteries, chemical works, &c. Large docks have been constructed, and coal is largely exported. With Carmarthen it returns one member to parliament. Pop. (1851) 8710; (1881) 19,655; (1891) 24,307.

Llanfairfechan, a pleasant little watering-place of Carnarvonshire, North Wales, at the base of Penmaenmawr, 7 miles WSW. of Conway. Pop. of parish (1851) 809; (1891) 2407.

Llangollen, a town of Denbighshire, North Wales, picturesquely situated on the Dee, 22 miles SW. of Chester and 26 NW. of Shrewsbury. It has a town hall (1866) and flannel manufactures, and is visited by tourists on account of the beauty of the famous Vale of Llangollen, and for its antiquities, among which are Dinas Bran or Crow Castle, Valle Crucis Abbey (1200), and Elise's Pillar (8th or 9th century). Plas Newydd, ½ mile S. of the bridge, was for half a century the residence of the two Irish recluses, the 'Ladies of the Vale,' or 'Maids of Llangollen,' Lady Eleanor Butler (1745-1829) and Miss Sarah Ponsonby (1755-1831), who were visited here by Madame de Genlis, Miss Seward, De Quincey, and many other celebrities. Pop. 5546. See Simpson's *History of Llangollen* (3d ed. 1852).

Llanidloes, a municipal and parliamentary borough of Montgomeryshire, North Wales, on the Severn, 56½ miles NW. of Hereford by rail and 56 SW. of Shrewsbury. Its interesting church, built partly with materials from Cwmhir Abbey, was restored in 1882. Considerable manufactures of flannel and other woollen fabrics are carried on; and in the neighbourhood are extensive lead-mines. With Montgomery, &c., Llanidloes returns a member. Pop. (1851) 3045; (1881) 3421; (1891) 2574.

Llanos (Spain), 'plains,' from Lat. *platus*, 'level'; pron. *lga'nos*) are vast plains in the northern portion of South America, in some parts barren and sandy, in others covered with luxuriant grass and stocked with innumerable herds of cattle. Over great portions, however, there is a heavy growth of timber. The Baneros resemble the Gauchos (q.v.) farther south.

Llanthony, on the Honddu, in Monmouthshire, 20 miles N. of Abergavenny, a Cistercian abbey, founded in 1108. Its church and chapter-house form a fine ruin in the Transition Norman style. In the Prior's Lodge, now an inn, Walter Savage Landor lived for three years after his marriage, until driven away by worries that harassed all his life. He had spent much toil and money on attempts to improve the natural sterility of the soil. Four miles up the valley is Llanthony 'Monastery,' founded by 'Father Ignatius.'

Llerena, a town of Spain, 83 miles by rail N. of Seville. Near here the British cavalry routed the French cavalry on April 11, 1812. Pop. 5592.

Llewellyn. See BRICKNOCKSHIRE.

Llorente, JUAN ANTONIO, the historian of the Spanish Inquisition, was born at Rincón del Soto, near Calahorra, in 1756. He was trained for the priesthood and took orders early, but his studies were chiefly secular—history, archeology, and jurisprudence—and in his memoirs he confesses an

inclination to the French philosophy of the day. His advancement, however, was rapid. He became vicar-general of the diocese in 1782, agent of the Inquisition at Logroño in 1785, and canon of Calahorra and secretary to the Inquisition in 1789. The projected reforms in the procedure of the Holy Office brought him into close connection with Jovellanos, and the imprisonment of the minister drove him into retirement for a time; but in 1805 he found favour with Godoy, whom he served by justifying on historical grounds his attack on the fueros of the Basque Provinces. In 1806 he was made canon of Toledo, and was on the high road to a bishopric when Napoleon put a stop to his promotion. He was, however, included among the Notables assembled at Bayonne to ratify the French usurpation. King Joseph, who stood in need of adaptable Spaniards, gave him a seat in his council of state, and appointed him to sundry posts more or less connected with confiscation; and in 1809, when the Inquisition was suppressed, placed all its archives in his hands that he might write its history. But the times afforded little leisure for the task. The ebb and flow of war kept Joseph always on the move, and Llorente followed his fortunes with a fidelity that would be admirable but for the fact that his life was not safe among his own countrymen. After the battle of Vitoria he effected his retreat to Paris, and there, translated into French under his own eyes by Alexis Pellié, the work came out at last in 1817-18. The Spanish edition did not appear till 1822, as the Inquisition, restored by Ferdinand, survived till 1820. The value and importance of the book, notwithstanding its want of method, were recognised at once. There was a 2d edition in 1818, and translations in German, English, and Italian followed speedily; but it provoked bitter feeling, to which Llorente added in 1822 by his *Portrait Politique des Papes*, and at the instance of the clerical party he was ordered to quit France forthwith. He set out for Madrid, and a few days after his arrival died (February 5, 1823), broken down by the fatigues of a hasty journey in severe winter weather. Llorente's time-serving character, his animus against the Inquisition, the Church, and the pope, and his admission of having burned documents have been urged as reasons against his trustworthiness. But the most learned of his opponents, Hefele, can bring no graver charge against him than that the number he gives for the victims at Seville in one year should have been distributed over several years and among several cities. His account of the burning of some of the papers is perfectly straightforward, and his sentiments as to the Inquisition are always frankly declared. It is open, of course, to its apologists to say that he may have kept back facts in its favour, but critics of unimpeachable impartiality and competence, Prescott, Ticknor, and Buckle, to name no others, testify to the accuracy and honesty of his work. His minor works, some twenty or thirty in number, include an account of the origin of the fueros of the Basque Provinces; the Annals of the Inquisition as far as the year 1530; a short autobiography, in which he defends his French partisanship as prudent patriotism; and his *Critical Observations on Gil Blas* (1822). See ISLA and LE SAGE.

Lloyd's is in the first place an association of underwriters, each of whom conducts his business according to his own views. For those views, or for the business transacted by individual underwriters, Lloyd's as a corporation is in no way responsible, except that the committee of Lloyd's before the election of any underwriting member requires that the candidate shall place in the hands of the committee security to meet his underwriting liabilities. For many years this custom has prevailed,

and the total securities thus placed at the disposal of the committee of Lloyd's amount to about £4,000,000. It is difficult to estimate the value of property annually insured at Lloyd's, but it probably amounts to about £400,000,000. Lloyd's as a corporation, and the committee as its executive, have little to do with marine insurance. Their business is to conduct the affairs of Lloyd's in its corporate capacity, to carry out the supply and distribution of shipping intelligence, and to guard as trustees the corporate funds and corporate property.

The name of Lloyd's is derived from a coffee-house kept by Mr Edward Lloyd in the 17th century. In 1692 Lloyd's coffee-house moved from Tower Street to Lombard Street, where it became the centre of shipping and underwriting business; and in 1774 Lloyd's moved from the coffee-house in Lombard Street to the north-eastern premises of the Royal Exchange, where it occupied, on the first floor, the rooms hitherto held by the East India Company. The wars, which lasted from 1775 with but short pauses till 1815, raised Lloyd's to the high position which it now holds, bringing home to merchants the necessity of covering their risks as effectually as possible. High premiums adequate to high risks were offered. Merchants of wealth became insurers of property afloat, and tens of thousands were written in the names of single underwriters at Lloyd's. The wars had the effect of bringing foreign marine insurance from all parts of the world to Great Britain, since the security of Lloyd's then, as now, was unequalled in the world. The membership of Lloyd's has greatly increased: in 1850 there were 210 underwriting members; in 1890, 592.

In the second place, Lloyd's is an enormous organisation for the collection and distribution of marine intelligence. The intelligence department of Lloyd's was originally established at Lloyd's coffee-house to meet the public desire for information with regard to vessels at sea. *Lloyd's News* was established in 1696, and reconstituted in 1726 under the name of *Lloyd's List*, which is thus the oldest newspaper existing in Europe at the present time, with the exception of the *London Gazette*. The intelligence department at Lloyd's has continually developed. During the Napoleonic wars the government was often indebted to the committee of Lloyd's for the earliest information of transactions all over the world.

The great wealth of Lloyd's, and the fortunes made there, attracted general attention, and in 1810 parliament appointed a committee to inquire into the affairs of the institution. From this inquiry Lloyd's emerged victoriously, and since that time has continued to assist in the promotion of every measure which might aid in the preservation of life at sea, the prevention of fraud in connection with marine insurance, and the rapid collection and distribution of maritime intelligence to all interested. The corporation has its agents in every port, and there is no line of sea-coast in the whole world which is not watched by some representative of Lloyd's. In 1871 Lloyd's was incorporated by act of parliament. The general introduction of telegraphy has caused an enormous development of the information received at and distributed from Lloyd's. Various works are published by the corporation for the benefit of the mercantile community, such as *Lloyd's List*, *Lloyd's Weekly Shipping Index*, and *Lloyd's Confidential Index*, *The Mercantile Navy List*, *International Code List*, and *British Code List* are edited by the Registrar general of Seamen, and published by Lloyd's. At Lloyd's is also maintained a *Captains' Register*, showing the services of every master in the mercantile marine; and much confidential information of great value to

underwriters is collected in the secretary's office for the benefit of members and subscribers to the corporation.

The value of signal-stations as a means of providing early shipping information is great, not only to underwriters, but to owners of vessels and cargoes, as it is frequently of advantage that a vessel making for some particular port should be intercepted and ordered to some other port. Vessels arriving off outlying signal-stations bring important intelligence as to derelicts and wrecks passed on their voyages; as also information of vessels in distress and requiring assistance. Vessels arriving from long voyages overboard are also reported at these stations. Not one vessel in ten bound to ports in the United Kingdom from distant ports arrives at her terminal port without first being reported from one of Lloyd's signal-stations. The corporation of Lloyd's now holds a similar position with regard to signal stations to that occupied by the corporation of the Trinity House with regard to lighthouses. These valuable aids in the preservation of life and property are one of the latest developments of this great corporation. Lloyd's also maintains an 'Inquiry Office,' where the relations of the crew or passengers in any vessel may obtain information without cost concerning the movements of that vessel or any other matter of interest to them.

LLOYD'S REGISTER is a society voluntarily maintained by the shipping community with the primary object of classifying vessels according to their strength and efficiency for the safe carriage of cargoes. It is the recognised authority on such matters in the United Kingdom, and also to a very considerable extent in foreign countries. The society's affairs are managed by a committee of fifty members, composed of merchants, shipowners, and underwriters, elected to represent the important shipping centres of the country. The numerous duties of the society are executed under the control of the committee by a staff of 134 ship and engineer surveyors in the United Kingdom, and of 121 appointed at the principal foreign ports. Rules are published annually by the society, embodying the best current practice in the construction of ships and engines. Both new and old vessels can be classed under these rules. In the case of a new vessel the plans for construction are in the first instance submitted to the committee, by whom they are examined and returned with such modifications as are considered requisite. The building of the vessel then proceeds under the supervision of the local surveyor, and when she is completed the surveyor forwards a detailed report for the consideration of the committee by whom the character is assigned.

Wood ships are assigned the character A1 as a first class for a term of years varying according to the materials and fastenings used in their construction. Lower grades of character are expressed by the symbols A1 in red and E. Iron and steel vessels are classed for an indefinite period under a system of frequent surveys, the varying degrees of strength being indicated by the characters 100A1, 90A1, and 80A1. Nearly 90 per cent. of the tonnage constructed in the United Kingdom is built under the supervision of the society's surveyors and classed in the register book. Altogether, over 8000 vessels of nine and a quarter million tons hold a classification assigned by Lloyd's Register, subject to periodical inspection by the society's officers.

The inspection of the machinery and boilers of steam-vessels during and after construction comes also within the scope of the society's functions. Under the authority of government it controls the testing of anchors and chains at eight out of the nine proving houses in the country, in accordance

with the provisions of the Chain and Anchor Act of 1871. It tests the steel intended for use in constructing ships and boilers, and inspects large forgings and castings; it provides for the survey and classification of yachts; and it has been entrusted by government with the fixing of maximum load-lines to merchant-vessels.

Lloyd's Register issues annually to its subscribers a register containing particulars of the classification of vessels to which characters have been assigned, together with many other details, constituting a very full record of their construction, history, &c. All other sea-going vessels of the world of 100 tons and upwards are included in the work, which contains particulars of the age, build, tonnage, dimensions, ownership, &c. of some 32,000 vessels. The society has existed in its present form since 1834, when it superseded two rival institutions having a similar object. The offices of the society are situated in White Lion Court, Cornhill, London.

Amongst several marine institutions bearing the name of Lloyd in different parts of the world, the most important are the Austrian and the North-German Lloyd. The former has its seat at Trieste, it was organised as a marine insurance society in 1833, but three years later enlarged the sphere of its activity by founding also a share company for steam-navigation to the Levant and Black Sea. Its vessels also traverse the Red Sea and the Indian Ocean, going as far as Hong-kong. The North-German Lloyd is primarily a shipping company, whose headquarters are at Bremen. It was founded in 1857, and maintains communication by means of large, swift, and excellently equipped ocean steamships with New York and Baltimore, Brazil and the River Plate, and (since 1885) with eastern Asia and Australia. See F. Martin's *History of Lloyd's* (1875), *Annals of Lloyd's Register* (1884), and *Chambers's Journal* (1886).

Lloyd's Bonds are obligations by railway companies under their seal, purporting to be for work done, or for materials supplied for the purposes of an undertaking, and covenanting to pay the debt and interest thereon. They were devised by the eminent English counsel, John Horatio Lloyd, to enable railway companies to exceed the powers of borrowing money granted to them by parliament. The issue of these bonds has sometimes been abused, being made without consent of the shareholders or of the statutory debenture holders of the company; but they are valid only when granted in *bona fide* to contractors and others, for work actually done, or materials supplied. They cannot be given for a mere loan of money to the company; and a company issuing them otherwise than authorised by statute forfeits to the crown the amount of the bond.

Llywarch Hen. See WALLS (LITERATURE).

Loach, a name applied to the members of a group of fresh-water fishes in the carp family (Cyprinidae). The mouth bears six or more barbels; the scales are small or absent; the air-bladder is more or less enclosed in bone. Most belong to the genus *Nemachilus*, which includes numerous carnivorous and edible forms frequenting rapid streams, and represented in Britain by *N. barbatus*, called in Scotland the *Baracha*. It is a small fish, about 4 inches long, of a yellowish white colour, with brown spots. The largest European form, *Mesogobius fossilis*, not uncommon in Germany, approaches a foot in length. A rare British species is *Cobitis loachi*. See Günther's *Introduction to the Study of Fishes* (Edin. 1880).

Load-line. See PLIMSOLL.

Loadstone, or MAGNETIC IRON ORE, a mineral consisting of a mixture of the ferric and ferrous oxides, $FeO \cdot Fe_2O_3$, or Fe_3O_4 , remarkable for

its highly magnetic quality. The name loadstone or lodestone ('leading stone') is derived from its power of drawing or leading bits of iron; the earliest magnets were pieces of loadstone, and the value of the ore for making a mariner's compass (see COMPASS) was early known; 'the lodestarr [polestar] draweth the lodestone as the lodestone the steel.' Loadstone is black, and has a metallic lustre; its hardness = 5.5 to 6.5, and its specific gravity = 4.9 to 5.2. It is one of the most common constituents of eruptive rocks, occurring in these generally in the form of small octahedra or irregular grains. Some rocks, such as certain basalts, contain so much magnetite as strongly to affect the compass. Larger and well defined crystals are met with in the crystalline schists, more especially in chlorite schist. Magnetite also occurs massive, associated with other iron ores, forming in some places irregular bedded sheets amongst the crystalline schists, and in other places entering largely into the composition of mountains, as in Sweden one of the richest iron-bearing regions in the world. The iron sands which occur here and there in river-beds and along certain sea coasts consist of magnetite which has been derived from the degradation of eruptive rocks.

Many strange beliefs have been held about the properties of the loadstone, and an interesting account of the true and untrue among these is given by Sir Thomas Browne in his *Polygraph Errors* (book ii, chaps. 2, 3). Thus, one species was said to attract flesh; again, its operation was hindered by garlic, by the diamond, by quicksilver. Heavy bodies such as chariots of iron could be suspended in the air by systems of magnets arranged. Again, it possessed valuable medicinal properties in cases of dropsy, ruptures, and gout; and had, moreover, magical efficacy to detect incontinence and theft, to divine, and to afford means of communication with absent friends.

Loan. See SOILS.

Loan, an express or implied contract whereby the property of one person is transferred into the possession of another, the borrower undertaking to return the thing or money lent to the owner. The delivery of chattels (movable property) by way of loan or deposit is in English law called a bailment. When goods are thus delivered merely for the convenience of the owner, as in the case of goods kept by a friend without charge, the depositary is liable only for gross negligence. If they are delivered merely for the advantage of the bailee, as in the case of a gratuitous loan, the depositary is bound to use the strictest diligence. Where the arrangement is for the advantage of both parties, as in the case of furniture hired from a shop, ordinary diligence will suffice.

A loan of money is usually made on an undertaking by the borrower to repay the money lent, and to pay interest thereon. The rate of interest was formerly restricted by the laws against Usury (q.v.), but there is now no law in the United Kingdom to prevent a lender from stipulating for any interest, however exorbitant. A lender has, of course, a right of action against the borrower; but he generally endeavours to secure himself by obtaining some special and easily enforced right against the debtor and his property. He may, for example, take a bill of exchange or promissory note for the amount, so as to acquire the special rights which the law confers on the holder of a negotiable instrument. Or he may secure himself by obtaining specific rights over some part of the debtor's property. Thus, the debtor may give him possession of some part of his property by way of Pawn (q.v.); or, if he retains possession of his property, he may make a

formal conveyance of it to the creditor by way of Mortgage (q.v.).

Loans are contracted not only by individuals, but by governments and public bodies. The aggregate debts of municipal corporations in the United Kingdom is very large, and the National Debt (q.v.) amounts to nearly 700 millions sterling. Loans of this class consist of capital sums, advanced for the most part by private persons, in consideration of payment of principal and interest or in consideration of annuities paid to the lender. When the subjects of one state lend money to the government of another, as, for example, when English investors buy Turkish bonds, international questions may arise in regard to payment. But it is now an accepted maxim that investors as such have no claim to the assistance of their government. When people lend money to Turkey they do so to obtain a high rate of interest; and they know, or ought to know, that 'high interest means bad security.' See C. Cotton's *Loans Manual* (1891).

Loanda, SAINT PAUL DE, chief town of the Portuguese possessions on the West Coast of Africa, lies on a small bay, some 210 miles S. of the mouth of the Congo. It has broad, tree-shaded but dirty streets, several churches, forts (1578), and the residences of the governor and bishop. The harbour is gradually sanding up, so that vessels lie $1\frac{1}{2}$ mile from shore. In 1888-92 a railway was made to Ambaca, 140 miles inland; gas was introduced in 1893. Pop. 50,000, of whom about 15,000 are Europeans.

Loango, a coast district of West Africa, stretching northwards from the mouth of the Congo to about 4 S. lat. By the Berlin conference of 1885 it was divided between the Congo Free State, Portugal, and France. The natural features and productions do not differ from those of the adjacent parts of Africa (see CONGO, GABON). The inhabitants, who call themselves Batiotes, are fetish-worshippers. The town Loango, formerly a place of 15,000 people, consists now of only a few mercantile establishments.

Loasaceæ, a natural order of calycifloral exogens, natives of America, and chiefly from the temperate and warmer parts of it. There are about seventy known species, herbaceous plants, hispid with stinging hairs. The genus *Loasa* sometimes receives the popular name of *Chili Nettle*.

Löban, a town of east Saxony, 12 miles SE. of Bautzen, has mineral springs and manufactures of linens, cottons, woollens, &c. Pop. 6977.

Lobelia, a genus of corollifloral exogens of the natural order Lobeliaceæ, named after the French botanist Matthias de Lobel (1538-1616). This order is nearly allied to Campanulaceæ, one of the most conspicuous differences being the irregular corolla. It contains almost 100 known species, natives of tropical and temperate climates, abounding chiefly in damp woods in America and the north of India. They are generally herbaceous or half-shrubby, and have a milky juice which often contains much esautheone. A poisonous character belongs to the order, and some are excessively acrid, as *Tupa foetida*, a Chilean and Peruvian plant, of which the very smell excites vomiting; yet the succulent fruit of one species, *Centropogon surinamensis*, is eatable. The genus *Lobelia* is the only one of this order of which any species are British. The Water Lobelia (*L. Dortmannii*) is frequent in lakes with gravelly bottom, often forming a green carpet underneath the water with its densely matted sub-cylindrical leaves. The flowers are blue, the flowering stems rising above the water. To this genus belong many favourite garden-flowers, as the beautiful Cardinal Flowers (*L. cardinalis*, *L. fulgens*, and *L. splendens*) and the Blue Cardinal (*L. siphilitica*), natives of the warmer

parts of North America, perennials, which it is usual to protect during winter in Britain. To this genus belongs also the Indian Tobacco of North America (*L. inflata*), an annual, with an erect stem, a foot high or more, with blue flowers, which has been used as a medicine from time immemorial by the aborigines of North America; both the flowering-herb and the seeds are imported into Britain. It is the former, compressed in oblong cakes, which is



Lobelia crinita (garden variety).

chiefly employed. A liquid alkaloid, *Lobeline*, and a peculiar acid, *Lobelic acid*, have been obtained from it. In small doses it acts as diaphoretic and expectorant; in full doses, as a powerful nauseating emetic; while in excessive doses, or in full doses too often repeated, it is a powerful acro-narcotic poison. It is the favourite remedy of a special class of empirics, and consequently deaths from its administration are by no means rare. Physicians seldom prescribe it now, except in cases of asthma.

Lob Nor, a dried-up lake of central Asia, in the desert of Gobi. Pejevalski in 1885 found 400 persons, mixed Turks and Mongols, settled on its confines. See ASIA, Vol. I, p. 486.

Lobo, JERONIMO, a Jesuit missionary, born at Lisbon in 1593, went out to India in 1621, but travelled back to Abyssinia in 1625, and was for nearly ten years superintendent of missions in Tigre. He died at Lisbon in 1678. From Lobo's Portuguese MS. account of his travels in Abyssinia the Abbé Legrand published a French translation in 1728, and of this again Dr Johnson produced an abridged English version in 1735—his first work. Sir Peter Wyche also translated into English parts of Lobo's MS. in 1669.

Lobos Islands, two small groups of rocky islands, about 12 miles off the coast of Peru, famous for the great quantity of guano which they produced.

Lobster (*Homarus vulgaris*), a species of Crustacean, of the order Decapoda, sub-order Macrura (see CRAYFISH). It differs from the crayfish principally in the following characters: the last ring of the thorax is not movable, but continuous with the rest; the scale of the antenna is small; there are twenty branchie on each side, and the claws are very powerful and unequal. One claw, usually the left, is thicker, more globose and heavier than the other, the biting edges being furnished with blunt tubercles of different sizes; the other claw is more slender and elongated, and its biting-edges are furnished with numerous small teeth. As an exception two claws, both of one kind or the other, may occur in the same individual. The colour during life is a beautifully clouded and varied bluish black, which changes to a nearly uniform red on boiling. It sometimes attains to the weight of 12 or 14 lb. when loaded

with spawn, although a lobster of 1 lb. weight or even less is deemed very fit for the market. The eggs (2000 to 12,000, of which perhaps 1000 are hatched) are deposited from the oviducts in autumn, and then become attached by adhesive threads to the swimmerets or abdominal appendages of the female. They are carried by the parent in this manner for several months, finally hatching about June and July of the following summer. When hatched the young swim about actively in the water, not at first crawling or walking like the adults. They differ from the adults in structure, chiefly in having outer appendages to the thoracic limbs; when first hatched they are about half an inch in length. Lobsters are exclusively carnivorous and very voracious. They are also very pugnacious, and in their combats often lose their limbs. But they exhibit in a remarkable degree the phenomenon of reescence, limbs rapidly growing again of the same form and structure as

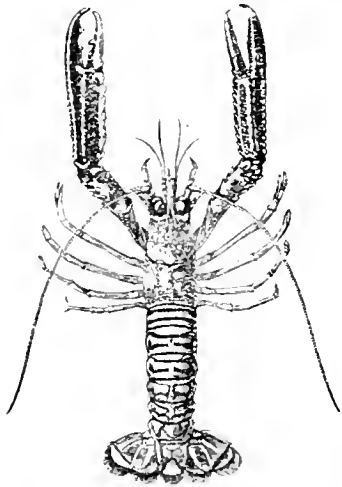

Norway Lobster (*Nephrops norvegicus*).

those that have been removed, though several moults are required before the full size of the new member is attained. Moulting, or the casting of the shell, occurs in adult lobsters once a year, in the young much oftener, in very old individuals not so often. The creatures are fairly abundant on the coasts of the British Islands and other parts of Europe. They are caught for the market in traps made either of basket-work or of netting stretched on wooden frames, each trap having one or more re-entrant orifices for the entrance of the lobsters. The traps are baited with dead fish. In 1885-95 the number of lobsters landed annually on the coasts of England and Wales varied between 500,000 and 700,000. The landing price is from £1. 5s. to £1. 10s. per 100. In 1890 a lobster-pond was undertaken at Lochbuie in Mull. The American Lobster (*H. americanus*) and the Cape Lobster (*H. capensis*) are the only other species known of the genus Homarus. The former is as valuable as the European species; its claws are much larger than those of the latter. Great quantities are canned and exported from Nova Scotia and New Brunswick, and from Portland, Maine, &c. The Norway Lobster (*Nephrops norvegicus*) is frequently taken on the British coasts, and appears in the markets. The eyes are kidney-shaped, and not round, as in the common lobster. The claws have also a more slender and prismatic form, and the colour is a pale flesh colour. It is said by some to be the most delicate of all the crustaceans; by others, to be inferior to the common lobster. The

Spiny Lobster, or Sea Crayfish (*Palinurus vulgaris*), is not uncommon on the rocky coasts of Britain, particularly in the south. It is believed to be the *Karabos* of the Greeks, and the *Loenusta* of the Romans. It attains a length of about 18 inches. The shell is very hard, and the whole body is rough with short spines. The antennae are very long, much longer than those of the common lobster. There are no claws or pincers, the first pair of feet being very similar to the others. The Spiny lobster is brought to market in London and elsewhere, but is inferior to the common lobster. Other species of these genera are found in other parts of the world. For anatomy, &c., see Huxley, *The Crayfish* (1880).

Lobworm, or LUGWORM (*Arenicola piscatorum*), one of the more sedentary Chaetopods, extremely abundant on the British shores, and very valuable as bait. It lives head downwards in a hole in the sand, which is partly lined by a yellowish-green agglutinating secretion from the skin of the worm. The hole is made as the animal cuts its way in earthworm-like fashion, and the devoured material, from which small organisms and organic debris are extracted, is passed out on the surface as spiral coils or 'casts,' familiar to every one who has walked over a low-tide stretch of sand. The animal is larger than the earthworm, sometimes a foot in length, and greenish brown in colour. The body is divided into a thickened anterior region, a median part with thirteen pairs of gill-tufts brightly coloured by the red blood, and a thinner posterior portion. The appendages are degenerate, but are represented by two rows of weak bristles on to the end of the gill-bearing region.



Lobworm (*Arenicola piscatorum*).

Local Government is a term used, in the United Kingdom, to express the control and administration of the local affairs of separate divisions and districts of the country by subordinate authorities. It is thus contrasted with imperial government, or the control and administration of affairs for the whole country by the supreme legislative and executive authority. Prior to the Reform Act of 1832 local government in the United Kingdom was of a very rudimentary character. The management of local affairs was almost entirely in the hands of the propertied and privileged classes; the great mass of the people had little or no participation in it. As regards the counties and rural districts, the justices of the peace in England, the commissioners of supply and justices in Scotland, and the grand jury and justices in Ireland were the exclusive governing authorities; while burghal affairs were practically in the hands of close corporations, either self-elected or chosen by privileged classes of burghesses. The first step towards realising local self-government was the reform of the municipal corporations in 1832-35, whereby the town-councils were made elective. Since then the course of legislation in this direction has been one of steady progress. Thus, in settling the government of urban communities, such as the local board districts of England and the police burghs of Scotland—the legislature has given them as full control of their affairs as the returned municipal boroughs. So the establishment of the poor law systems for each of the three Kingdoms between 1835 and 1845, and the creation of poor law unions in England and Ireland, first introduced life and activity into the rural districts. The great area of local administration is, especially since the Local Government Act

of 1888, the county, and is fully treated under that head. Other important areas, separately treated, are the parish and borough, for both England and Scotland. In Ireland, besides the county and town, the union had exceptional importance; and till the Irish Local Government Act of 1898 superseded it by County Councils, the grand-jury (see JURY) had wide administrative powers. The (optional) transfer of most of the proceedings in Scottish private bill legislation to Scotland (by act of 1899) increases the autonomy of the northern kingdom.

The Local Government Board, to which in 1871 the powers of the English Poor law Board (1834) were transferred, is, in form, a committee of the Privy-council, but the work is done by the political heads of the department (the president and parliamentary secretary, both usually members of the House of Commons) and a staff of clerks. Among the matters placed under the supervision of the Board may be mentioned the areas of parishes, &c., local taxation returns, the administration of the poor-law, sanitary improvements, baths and wash-houses, vaccination, and the prevention of disease. The Local Government Board of Scotland is provided over by the Secretary for Scotland. From the nature of the case, the multiplicity of subjects included in Local Government are best treated in a large number of separate articles, some of which are noted below.

See Probyn, *Local Government and Taxation* (1882); Gouly and Smith, *Local Government in Scotland* (1880); Mackenzie Chalmers, *Local Government* ('Citizen Series,' 1874-83); *Local Government and Taxation*, by various authors, in 'Imperial Parliament Series' (1885); E. Odgers, *Local Government* (1899); also the several articles:

Advocate (Local).	Government.	Poor-laws.
Appeal.	Hygiene.	Prisons.
Borough.	Ireland.	Privy-council.
Burial.	Jury.	Prosecutor-fiscal.
Channel Islands.	Justice of the Peace.	Prosecutor.
City.	Licensing Acts.	Roads.
Coroner.	Lord-lieutenant.	Scotland.
County.	M in (Ireland).	Sherrif.
County Courts.	Nuisance.	Socialism.
Criminal Law.	Pa. sh.	Tax.
Education.	Police.	Warrant.

Local Option is a term for the power which temperance reformers have of late sought to secure for the ratepaying inhabitants of any community, enabling them to regulate the liquor traffic within their bounds as to a certain majority of them shall seem best, either by maintaining unchanged, increasing, diminishing, or wholly suppressing the houses for the sale of intoxicating liquors. See LICENSING, LIQUOR LAWS, and TEMPERANCE.

Lochaber, a district in southern Inverness-shire. The Lochaber Axe is a variety of the Halbert (q.v.), with a long handle and a bill-like blade, behind which, on the other side of the shaft, is a formidable hook. This weapon was formerly used by the Highlanders of Scotland and by the native Irish, and is believed to have been introduced into both countries from Scandinavia (see Scott's *Waverley*). It was carried by the old city guard of Edinburgh. The song 'Farewell to Lochaber' is by Allan Ramsay.

Lochleven, a beautiful oval lake of Kinross-shire, 23 miles NNW. of Edinburgh. Lying 353 feet above sea-level, and eight by Benarty (1467 feet), the West Loamond (1743), and other hills, it measures 3½ miles by 2; discharges by the Leven, flowing 16 miles eastward to the Firth of Forth; is 10 to 90 feet deep; and has an area of 3496 acres, drainage operations having reduced its size by one-fourth in 1826-36. Of seven islands, the largest are sandy, treeless St Serf's Inch, an early seat of the Culdees (q.v.), and Castle Island, with the 14th-century keep of a castle which in 1567-68 was

for ten months the prison of Mary Queen of Scots. Since 1633 and earlier the loch has been famous for its delicate pink-fleshed trout, and since 1856 for its fly-fishing, there now being twenty boats on it, and some fifty annual angling competitions, whilst the yearly take has varied from 6092 trout of 5385 lb. in 1877 to 23,516 of 21,074 lb. in 1888, and 10,933 of 9201 lb. in 1890. See Robert Burns-Begg's *History of Lochleven Castle* (2d ed. Kinross, 1877). See also LIVEN (LOCH); and for Lochs Loamond, Long, &c., see LOMOND, &c.

Lochmaben, a market-town of Annandale, Dumfriesshire, 10 miles by rail NE. of Dumfries. It stands amid seven lochs, two of which contain the rare vendace, and has a town-hall (1878), with a statue in front of it of Robert Bruce, and the ruined castle of the Bruces. A royal burgh, it unites with Dumfries, &c. to return one member. Pop. 1039. See W. Graham's *Lochmaben* (1865).

Lock, an arrangement for fastening doors, drawers, &c., and requiring a key or other similar contrivance to open it. The early Egyptians used locks of rude construction, generally made of wood; and locks and keys of bronze and iron have been found in large numbers in Pompeii and Herculaneum. Fig. 1 represents the ancient Egyptian lock in section: *a* is the case, fastened to the door; *b*, the bolt; in the upper part of the case are three openings, *c*, each containing a pin with a head to prevent its falling too far down. When the bolt is pushed home towards *b*, the pins fall into the corresponding three holes, *d*, preventing its being withdrawn. The key is a piece of wood, *e*, which is pushed into the opening, *f*, in the bolt, and by means of its three pins the pins in the case are pushed up while the bolt is withdrawn. An exactly similar lock is still used in the Faroe Islands, and one very like it in St Kilda. The Chinese for many hundred years have had a much superior wooden lock with tumblers.

During the 15th, 16th, and 17th centuries very ingenious and complicated locks, richly ornamented with hammered iron work, were made, especially in Germany, and in every collection may be seen more or less fine specimens. These, however, were necessarily very expensive, and could only be used by the wealthy, and the lock in ordinary use up to the beginning of the 19th century was the common

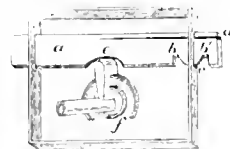

FIG. 2.



FIG. 3.

spring-lock shown in fig. 2, and which is still used for ordinary purposes. The bolt, *a*, passes through an opening in each side of the case, and is held in position by the two notches, *bb*, which are pressed against the bottom of the opening, *c*, by the spring, *d*, as the bolt is locked or unlocked. The key, acting in the semi-circular notch, *e*, in the bolt, pushes it either to one side or the other as required; the fig. represents the bolt midway between open and locked. Certain notches in the key fitting into corresponding wards, *f*, fastened to the plate of the lock, are supposed to prevent any other

instrument but its own key from opening the lock. The first improvement on this was the common tumbler-lock (fig. 3), which represents the simplest form of it: *a* is the bolt; *b*, the tumbler, with a projection, *c*, which is pressed by the spring, *d*, into the notches, *e*, *e*, according as the lock is open or shut. The key, by the one movement, raises the tumbler and moves the bolt.

Barron's lock, patented in 1778, was a development of the tumbler principle. By putting the notches in the centre of the bolt instead of on the top edge, the pin in the tumbler had to be fitted to an exact height to pass the bolt, rendering it much more difficult to pick. Barron subsequently added a second tumbler which had also to be passed by the bolt. Barron's form of construction is still in use, and it may be considered the parent of the modern many tumbler or lever lock, of which Moses Bird's (1780) was the first.

The lock patented by Joseph Bramah in 1788, and still one of the recognised best locks for certain purposes, is of a different construction.

An inner barrel turning inside a fixed cylinder has a central pin on which the key works. The key (fig. 4) is a simple pipe with generally four slits, *a*, *a*, and a pin, *b*; when it is inserted and pressed down, the slits press on corresponding slides working in the inner barrel, till, arriving at a certain point, the barrel is released and can be turned round by the pin, *b*; another pin on the barrel moves the bolt. A spiral spring on the central pin keeps the slides in their original position till pressed down by the key. The varying depths of the slits in the key agree with the distance which the different slides have to be pressed down; and, as no two locks are alike in this respect, each key can only open its own lock. So much confidence had the Messrs Bramah in this lock that during the Great Exhibition of 1851 they offered a prize of two hundred guineas to any one picking it, which prize was gained by Mr Hobbs, an American, who occupied fourteen days in devising and making tools, and fifty-one hours not idly at work on the lock.

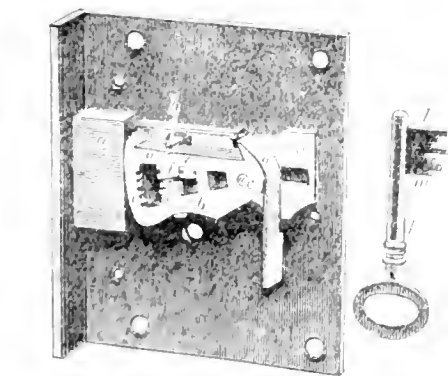

Fig. 5.

Chubb's lock, originally patented in 1818, is a further development of the many tumbler principle. It is shown in fig. 5, which represents it unlocked, and with the inner plate removed the better to show the movement: *a* is the bolt; *b*, the tumblers, six in this instance, which move independently on the common pin, *c*, each having one of the six springs, *d*, to keep it in position. The stump, *e*, riveted to the bolt, must

pass through the *gate*, *f*, in all the tumblers before the bolt can be shot. As this gate is in a different position in every tumbler, they must be raised to correspondingly different heights before they coincide for the stump to pass. For this purpose the key, *L*, has different steps so arranged that, when it is turned in the lock, each step raises its own tumbler to the proper height, and the step nearest the end of the key, *L*, shoots the bolt; the stump passing through the coinciding gatings and slipping into the space, *g*, as the tumblers, released by the key, resume their original position. In opening the lock the reverse of this movement takes place. A pin, *h*, fixed on the backmost tumbler and reaching over the tops of the others is called the detector. Should any false key be tried in the lock when locked, or any other means used which should raise either of the tumblers too high, an ingenious arrangement fixes it so that the lock is obstructed and cannot be opened, even with its own key, till the fixed tumbler is released. This is done by making an extra forward movement of the key, when the tumbler will resume its normal position. This detector movement is intended as a precaution against burglars, and also to record any attempt to pick the lock. False notches, *i*, *i*, are made in the tumblers to defeat attempts to pick the lock by feeling for the different gatings by backward pressure of the bolt applied by ingenious instruments—a method, difficult as it may seem, which has been successfully used against all tumbler-locks, unless specially safeguarded. A movable circular curtain attached to the keyhole in the inner plate is moved by the aftermost step of the key, *m*, as it is turned round. This prevents an inspection of the tumblers for picking purposes by means of a reflector introduced into the keyhole, while they are moved by any instrument, as nothing can be turned round in the lock without also turning the curtain.

Hobbs's protector lock has a series of tumblers as in Bird's and Chubb's locks, but, in addition, has what is termed a *protector*, shown in fig. 6. It consists of a shaped lever,

a, *b*, working on the pin, *c*, which is riveted into the bolt, *A*, and it is kept in position by the friction spring, *e*. The stump, *b*, is fixed to the protector, and, passing through a hole in the bolt, acts on the tumblers (not seen in the fig.) at the other side

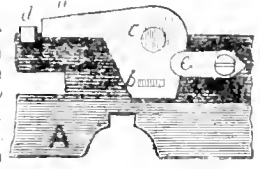

Fig. 6.

of the bolt. This arrangement entirely prevents feeling for the gatings of the tumblers by pressing back the bolt. If any attempt is made to push back the bolt when locked, it only moves the protector enough to bring down the long arm, *a*, in front of the pin, *d* (fixed in the back plate of the lock), as shown in the fig. This prevents any further movement of the bolt till the protector is set free by a slight turn of the proper key. This lock, when in combination with another ingenious arrangement called the *preventing notch*, which prevents tampering with false keys, has successfully resisted all attempts to pick it.

Lord Grimthorpe (formerly Beckett Denison) invented a modification of the tumbler lock which locks with a handle, only requiring a small key to open it. The keyhole is so narrow that no instrument strong enough to impair the lock can be introduced. It has other advantages, and its inventor claims that it is unpickable. It has not been patented. He is also the inventor of a dust-excluder for the key-holes of locks, operated by a spiral spring.

Many other varieties of the tumbler or lever

lock have been invented which we have not space to describe.

Combination locks are sometimes used for burglar-proof safes. In these locks the tumblers are represented by wheels, generally four in number, which can be turned independently in connection with an index on the outside of the safe. The lock can only be opened by making certain movements of the handle on the index, which cause the gatings in the wheels to coincide. The combination of numbers on the index with the different wheels can be altered at pleasure, and, of course, the lock can only be opened by those knowing this combination. The weak point of this lock is that the combination may be forgotten. The Yale time-lock is an improvement, by Mr Yale of Philadelphia, on the time-lock invented by Rutherford of Jedburgh, Scotland, in 1831. A watch in combination with the lock may be set so that the lock can only be opened at a particular hour even by the owner.

Changeable key locks were first introduced into England by Mr Hobbs, who brought Day and Newell's *parantoptic* lock to London in 1851. After many improvements, Mr Hobbs perfected this lock in 1862, and in 1865 the firm of Hobbs, Hart, & Co. introduced a simpler and cheaper form of it. By an ingenious modification of the tumblers, which we have not space to describe, the lock may be locked by any one of a great number of keys, but can only be opened by means of the one which locked it. Some of these locks afford a possible choice from about 60,000,000 keys, any one of which will lock it, and which must be used to open it again. To avoid the necessity of having a number of keys, different webs are supplied which fit on the key pipe to form the key. The webs may be kept in the safe, one taken out at random to lock up with; the web removed from the key carried away in the waist-coat pocket, and the key hung up anywhere, useless till the web is brought back.

In the ordinary safe locks the bolts are necessarily on a large scale, and, to prevent the carrying about of a key of corresponding magnitude, the bolts are usually shut by means of a handle, and a small lock with a small key locks one of them and fastens them all.

Latch locks used on street doors which shut of themselves, and are opened by means of a handle

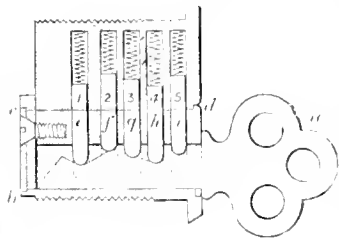

Fig. 7.

d is a movable barrel turning inside the lock; 1, 2, 3, 4, 5 are five pins pressed down by spiral springs working in holes in the fixed part; *e, f, g, h, i* are five corresponding pins, moving in holes in the inside barrel; they are of irregular lengths, and when the key is out, *e, f, g, h, i* drop down, as shown by the dotted lines, allowing 1, 2, 3, 4, 5 to drop into the holes in the barrel, fixing the lock. As the key, which has indentations exactly corresponding with the varying lengths of *e, f, g, h, i*, is pushed in, it raises those pins till they and 1, 2, 3, 4, 5 coincide at the junction of the barrel and the fixed part of the lock. The barrel may then be turned and a pin on

it shoots the bolt, not shown in the fig. The key is a thin piece of tempered steel weighing only a small fraction of an ounce, and the keyhole correspondingly narrow.

Locks made for various purposes, such as doors, drawers, writing-desks, portfolios, enboards, &c., however differing in arrangement, are all constructed on the same principle. The *pulllock*, in which the lock is a separate arrangement, is precisely similar to other locks except in shape. It has also a movable bow which is hooked into a staple or other fastening and then locked.

Locks for drawers, enboards, and the like, which only require to be opened on one side, are generally made with a central pin on which the key, with a pipe, works; but in locks which must be opened from both sides this arrangement is impossible, and the key is solid, working through a hole in the lock. It must, however, be symmetrical, so as to exactly reach the turning place of the lock from either side. Locks which are mortised into the thickness of the door are called mortise locks.

Many ingenious automatic latches have been invented for cabinets and the like, which shut of themselves when the door is closed, and can be pulled open without a key or turning a handle; they are used when security is not required, only a means of keeping the door closed.

See Price's *Treatise on Locks and Keys* (1856); Sir E. Beckett (Denison), *Treatise on Locks*; Hobbs and Tomlinson, *Treatise on the Construction of Locks* (new ed. 1868); and G. H. Chubb, *Protection from Fire and Theft* (1878).

Lock, on a river or canal, is an arrangement of two parallel floodgates, by which communication is secured between two reaches of different levels. Without locks, canals are an impossibility in any but exceptionally level country. The principle of locks is explained in the article CANAL, Vol. II. p. 697. The invention of the lock has been claimed for the great Leonardo da Vinci or other Italian engineer of the 15th century; but there seems ground for affirming that the principle was known and used in Holland a hundred years earlier.

Lock of a gun. See GUN, FIREARMS, and BREACH-LOADING.

Locke, JOHN, one of the most conspicuous figures in the intellectual history of modern Europe, in whom, directly or indirectly, the course of opinion, especially in the 18th century, is probably more represented than by any other man. Locke was a native of Somerset; Belton, the rural home of his youth, is 6 miles from Bristol. It was at Wrington, 10 miles from Belton, that he was born, on the 29th of August 1632. Our picture of his boyhood is faint. He lost his pious mother when he was a child. His father, a country attorney, was a considerable factor in the formation of his mind, during fourteen years of home-training in the small Puritan household, which consisted of the father and an only brother, who died young. In Locke's tenth year the Civil War broke out. He was at Westminster School in the years in which the assembly of Puritan divines was discussing Calvinistic theology, and in one of which he may have seen the tragedy at Whitehall in which the Puritan revolution culminated. In 1652 we find Locke at Oxford, after which the picture becomes more distinct. Christ Church was then ruled by John Owen, the Puritan divine, and Cromwell was chancellor of the university. The Aristotle of the schoolmen still determined the course of study, much to the dissatisfaction of young Locke, who preferred facts to words, and persons to books. But free experiential inquiry

was finding its way into Oxford, though not into college lectures, and Locke afterwards confessed the early influence of the spirit of Descartes upon himself. The Restoration found him in 1660 a senior student in Christ Church. For a time he lectured as a college tutor, till the little property of Belton became his by inheritance after the death of his father in 1661. He had now to determine his career. Notwithstanding an inclination to theology, his growing sympathy with free inquiry, in reaction against scholasticism, and against the intolerance and fanaticism of which he complained among the Puritans, discouraged an ecclesiastical career. 'I found,' he says sarcastically, 'that a general freedom is but a general bondage, and that the popular assertions of liberty are the greatest engrossers of it too, and not unjustly called its keepers.' Experiments in medicine, which much engaged him in these years, show his bent to the inductive interpretation of external nature, and aversion to the 'vermicate' questions of the schools. Before 1666 he was in a sort of amateur practice in Oxford, and, although he never took this degree, he was in after-life familiarly known among his friends as 'Doctor Locke.' The philosophic temperament is apt to make a merely professional career irksome; and, besides, he inherited a delicacy unfavourable to medical practice, which ended in the chronic consumption and asthma against which he bravely struggled in later years. Thus medicine did not absorb his attention. Problems of society, the relations of church and state, and above all the right and duty of religious toleration, as his commonplace books prove, were revolved in his thoughts in those Oxford years, always in sympathy with individual freedom and in a spirit of prudential utilitarianism.

It was in the summer after his return from Germany, where he had spent the winter of 1665, that an incident occurred which finally determined this last disposition, for thenceforward he was 'often a man of business, and always a man of the world, without much undisturbed leisure.' Medical practice accidentally brought him into connection with Lord Ashley, soon after first Earl of Shaftesbury, who was visiting Oxford for his health. The meeting ended in a lasting friendship, sustained by common interest in liberty; and in the following year Locke, at Exeter House, became Lord Ashley's confidential secretary. The change did not check his scientific experiments, in which he was encouraged by Sydenham and other savants with whom life in London opened intercourse, while the political experience of Exeter House was in the line of previous interests. It was not long after he entered it that the turning point in his intellectual career was reached. A remission of friends, meeting in the winter of 1670-71 for the discussion of problems social and theological, perplexed in certain inquiries, welcomed Locke's suggestion, that before pursuing them they should face a previous investigation—as to what questions the human understanding was or was not fitted to deal with. This problem, then undertaken by Locke himself, proved unexpectedly large. His best energies, given to it during the seventeen following years, issued in 1690 in the famous *Essay Concerning Human Understanding*.

Those seventeen years were spent partly in England, amidst the tumult of public affairs, partly on the Continent in comparative retirement. In 1672, when Shaftesbury became chancellor, Locke was made Secretary to the Board of Trade. The fall of Shaftesbury three years later enabled his secretary to retire to France, where he lived till 1679, for health and study, chiefly at Montpellier and at Paris. In France he

formed friendships with physicians, naturalists, and travellers more than with metaphysicians; although it was the brilliant era when French metaphysic was represented by Arnauld and Malebranche, whilst Spinoza was (till 1677) in Holland and Leibnitz in Germany. In 1679 Locke returned to London and to Shaftesbury, who was restored to power for a short time, and lived with him in the years of plots and counterplots which preceded the earl's flight to Holland in November 1682. Locke, under suspicion in England, as the confidant of Shaftesbury, became before the end of 1683 an exile in Holland, then the European home of religious and civil liberty. There, during five years of exile, he resumed the studies which affairs in England had often interrupted, and matured voluminous writings for the press. At Amsterdam Limborch, the leader of liberal theology in Holland, and Le Clerc, its most eminent man of letters, became his intimate friends. The intercourse strengthened Locke's theological liberalism, and soothed the pains of exile, aggravated by the withdrawal of his senior studentship in Christ Church, of which he was suddenly deprived in 1684 by the king's command. His first home in Holland was at Amsterdam—his last was at Rotterdam, where the *Essay* was finished.

The political struggle which had been going on for half a century in England was consummated by the Revolution of 1688-89, of which, then unknown to fame, he was to be the philosophical defender. This opened the way for his return, to play his part in authorship, with London at first as the stage of operations. Immediately afterwards, in February 1689, he declined, for health's sake, the post of ambassador at Brandenburg, contented with a modest Commissionership of Appeals as official recognition by the new government. The course of affairs after the Revolution fell short of his hopes. The Toleration Act of 1690 was inadequate, and the withdrawal of the Comprehension Bill, for uniting England in a liberal national church, was another disappointment. Locke made his first appearance as an author late in life. He turned to authorship in the public interest of individual freedom—religious, political, and intellectual. An *Epistola de Tolerantia* was his first contribution, written in 1685, addressed to his Dutch friend Limborch, published anonymously at Gonda in Holland in 1689, a few weeks after his return to England, and translated into English in the following summer by William Popple. A treatise on *Civil Government*, ready for publication when he came home, followed early in 1690; this was also anonymous, and, like the *Epistola*, a defence of individual liberty in another relation. Its economical principles anticipate Hume and Adam Smith, and its principles of jurisprudence are in advance of Grotius and Puffendorf. The *Essay Concerning Human Understanding* appeared in March 1690, unfolding the philosophy of which the treatises on Toleration and on Government were special applications. The *Essay* was Locke's first public acknowledgment of authorship. His philosophy is embodied in these three works.

His ailments had increased in London. It was then, in 1691, that the home of his old age, the brightest of all his homes, opened to receive him. This was the manor house of Oates in Essex, near Epping, the country seat of Sir Francis Masham. Lady Masham was the accomplished daughter of Cudworth (q.v.), the philosophical theologian; Locke had known her family before he went to Holland. Here, for the fourteen remaining years of his life, he enjoyed as much domestic peace, literary leisure, and social intercourse as was consistent with broken health and occasional public

service in London, and his work in the study was resumed with characteristic industry and method. The abundant authorship of the two preceding years now involved him in controversies which lasted to the end of his life. The *Answer* of a certain Jonas Proast of Queen's College, Oxford, to the *Epistola de Tolerantia* had led to Locke's *Second Letter* in 1690. A rejoinder in 1691 was followed by an elaborate *Third Letter* in 1692. Questions of economics and the currency were subjects of other tracts in 1691 and 1695. When he was in Holland he had corresponded with his friend Edward Clarke of Chipley in Somerset about the education of his son, and those letters made the substance of the *Thoughts on Education* in 1693, a characteristic work which still holds its place among educational classics. Proposals for ecclesiastical comprehension, and his own desire for union among Christians, made him anxious to show how few and simple the essential facts of Christianity were, and to bring men to agree to differ about all beyond. One result was the anonymous volume, in 1695, on the *Reasonableness of Christianity*, in which he tried, in the spirit of the *Essay*, to recall Christianity from the verbal reasonings of dogmatic divines, which had disturbed the unity of the church, to its original simplicity in Scripture. This theological departure, followed by excursions in criticism in the last years of his life, which appeared as posthumous *Commentaries on St Paul's Epistles*, was a distinctive feature of the literary life at Oates. In 1696, as a Commissioner of the Board of Trade, with an income of £1000 a year, he was again involved for the four following years in official cares. But they were not years of literary idleness. Successive editions of the *Essay*, in 1694, 1695, and 1700, with important additional chapters in the first and last; defence of its philosophy against the adverse criticism of Norris, Stillingfleet, Sergeant, Burnet, Lee, and Leibnitz; an *Examination* of Malebranche, and *Remarks* on Norris, published posthumously; vindications of the *Reasonableness of Christianity* against theological critics; and the well-known tractate on the *Conduct of the Understanding*, kept him busy in the study at Oates. The *Essay*, translated into Latin and French, was spreading over Europe. But he was now gathering himself for the end. In 1700 he ceased to publish. One attack only moved him in the four years which followed. In 1704 his old adversary Proast renewed the contest, and the fragment of a *Fourth Letter on Toleration*, published in the posthumous volume, exhausted Locke's remaining strength upon the theme that had engaged him at Oxford forty years before, and had been the ruling idea ever since. All that summer he declined, nursed by Lady Masham and her step-daughter Esther. On the 28th October 1704 he passed away, as he said, 'in perfect charity with all men, and in sincere communion with the church of Christ by whatever names Christ's followers call themselves.' His tomb may be seen on the south side of the parish church of High Laver, a mile from Oates, bearing a Latin inscription prepared by his own hand.

Locke's *Essay* presents the philosophical foundation of the right of the individual thinker to follow freely the findings of experience; and, partly even by its metaphysical defects, it has suggested the chief problems which have occupied modern thinkers since it appeared. Its 'design,' according to its own words, was, 'to inquire into the original, certainty, and extent of human knowledge, together with the grounds and degrees of belief, opinion, and assent;—and this as a means to correct the chief cause of human error, which its author found in men's proneness to ex-

tend their inquiries to matters beyond their reach, and then to cover their ignorance by empty phrases, or by dogmas which they assumed to be 'innate,' and therefore out of the reach of criticism. He wanted to make a faithful report, founded simply upon mental facts, as to how far a merely human understanding can go, in the way either of certain knowledge or of more or less probable presumption; and in what man must be contented with ignorance. Although a true report might show that human knowledge must for ever 'fall far short of perfect comprehension of whatsoever is,' it might be 'sufficient for our state;' and at anyrate we cannot overcome facts.

The *Essay* is divided into four books. Only the fourth deals directly with its 'design.' The first book is a preliminary argument against the innateness of any part of our knowledge, meant to open the way for the statement of Locke's main position—that whatever any man can know, or reasonably believe in, or even conceive, is dependent on human experience. The essence of the *Essay* is in its proof that knowledge cannot in any degree have been consciously innate in each man; for it must be in all cases a gradual growth, dependent upon experience, in which we are liable to error. The argument might be thus put: All truths and all errors are expressed in propositions, and every proposition contains two terms, which, if the proposition is intelligible, must each contain an 'idea' or meaning. We may have ideas without having knowledge, but we cannot have knowledge, or even opinion, without having ideas; for 'having ideas, Locke tells us, means 'speaking intelligibly.' Propositions which contain *ideal* terms cannot express truth, or even error, and only connect empty sounds. Now, how do the ideas or meanings which *can* form the subjects and predicates of our propositions enter into human consciousness? All our ideas, the most complex and abstract, as well as the simplest, Locke undertakes to show, are ideas which refer either to data that happen to have been presented through our five senses, or to operations of mind which have been made objects of reflection. If we pretend in words to extend our range further, 'we shall succeed no better than if we went about to clear the darkness in the mind of one born blind, talking into him the ideas of light and colours.' Words which do not mean either what is sensuous or what is mental must be empty words. The proof of this fundamental thesis is offered throughout the second and third books, which thus prepare for the settlement of the proper problems of the *Essay* in the fourth. Much of the proof consists of logical and psychological analysis of the metaphysical ideas of space, duration, infinity, substance, personality, causality, and power, which are taken as 'crucial instances.' If even those ideas must depend upon experience in order to become ideas, *a fortiori* none others can have been consciously born with us before we had experience. The proof is that, if all elements due to experience are left out, the ideas now mentioned must disappear. In the 13th and most of the remaining chapters of the second book this argument is worked out. But here Locke seems too ready to take for granted that, if those crucial ideas are unrealisable without data of experience, it necessarily follows that they involve nothing else than accidents of external or spiritual experience. He was led to interpret 'innateness' as he did partly by his assumption that nothing can be '*in* a mind' of which the mind is not at the moment conscious. He thus overlooks the fact that we are conscious at each moment only of a small part of what—because potentially involved in, and presupposed by, our spiritual experience of the

universe—responds consciously in each man's mind on an adequate appeal.

After this analysis of the possible range of man's ideas, Locke passes to the intuitive and demonstrable, the probable, and the erroneous judgments into which ideas enter. We are thus led into the fourth book, which reports upon the intuitive facts and principles which constitute knowledge. Locke's refusal of immateness (in his meaning of 'innate') to ideas, and *a priori* to knowledge which depends upon ideas, does not imply that he ignores intuition. On the contrary, after arguing strenuously against the immateness of our ideas of morality and of God, he is not less strenuous in arguing for our having an intuitive certainty of the truths of pure mathematics and abstract ethics, and for our being intuitively certain of the individual fact of our own existence as self-conscious, as well as of the existence of external things, as far as they are actually felt, and above all for our having a demonstrable knowledge of the existence of God or Eternal Mind 'as certain as any conclusion in pure mathematics.' Indeed, in his 'demonstration' of God's existence he presupposes in our idea of causality transcendental elements with which his description of that idea in the second book can hardly be reconciled. On the whole, we have intuitive knowledge (so Locke reports) in abstract logic, in abstract mathematics, and in abstract ethics; and we have also an intuitive knowledge of the facts of our own existence, of the existence of actually felt things of sense, and of the existence of an Eternal Spirit: it is on the light of intuition, he says, 'that all the certainty of this knowledge depends.' But all else upon which human understanding can be exercised is referred by the *Essay* to the spheres either of more or less probable presumption or of ignorance. All judgments about absent things of sense; about the relations among the qualities of matter, primary and secondary, or about its laws; and about the attributes of spirits human or divine, can at the most be probable presumptions. Hence probability is virtually the guide of human life. Science of absent facts of sense (if science means intuitively demonstrated truths) is beyond man's reach. The chief exercise of a human understanding must be balancing of probabilities and comparing the relative weight of objections, alike in the so-called physical sciences and in common life. Whether physical science, or even the probable propositions of ordinary life, could be formed without the latent presence in experience of universal and necessary judgments, presupposed in, while incapable of being referred to, its contingencies, Locke does not inquire. His aversion to presuppositions and maxims, to which he traced the empty verbalism and dogma against which he constantly warned, seems here to influence him. He sometimes wrote as if he failed to see that, without presuppositions and principles of some sort, intellectual and moral, being ready to spring out of their latency into experience, there could be neither reasoned scepticism nor reasonable faith. The most significant philosophical discussions of the last two centuries have been about the presence or absence of transcendental presuppositions and principles in our experience; and about man's consequent relation to the infinite and the eternal. Berkeley's *Principles of Human Knowledge*, Hume's *Inquiry* into the understanding, Reid's *Inquiry* into the principles of common sense, Kant's *Kritik of Pure Reason*, Hegel's ontological dialectic, Comte's positivism, and Herbert Spencer's generalisations of universal evolution and involution, are all in their respective ways concerned with questions about the roots of experience which Locke left indeterminate. Locke's teaching in his other works is influ-

enced by what is taught in his *Essay*. Thus, his favourite idea of free toleration for the individual expression of religious belief—then a paradox, now a commonplace—is founded on the dependence of man's knowledge on experience and on the unfitness of persecution as a means of introducing truth to a human mind; while his refusal of toleration to atheists is in harmony with that 'mathematical certainty of God's existence' which he reports to be attainable by every man who uses his faculties enough. The same intellectual individualism pervades what he wrote about government, the education of the young, and the reasonableness of Christianity.

Locke's character is reflected in his works. In all that he wrote and did he is pre-eminently himself, in his caution and calculation with an approach to timidity, steady adherence to the concrete of experience, indifference to abstract speculation, suspicion of mystical enthusiasm, calm reasonableness, love for truth, and ready submission to facts even when they could not be reduced to system in a human understanding. His temperate aim was not to explain the universe, but to adapt his own intellectual life and that of others to the actual conditions. He sought to awaken the intellectual spirit, and to bring about an amendment of the operations of the understanding, more than to solve the enigmas of existence. Hence the lasting educational value of his authorship.

Numerous editions of Locke's works, individually and collectively, have appeared, about 40 of the *Essay* alone, besides translations into Latin, French, and German. Of the collected editions none are adequate, but the best is probably that of Bishop Law in 4 quartos (1777). Among criticisms of the *Essay*, the *Nouvaine Essais de Leibnitz* (1765) still takes the foremost place. Cousin's *Lectures on Locke* (1829), Webb's *Intellectualism of Locke* (1857), and Green's criticism in his Introduction to Hume (1874) are noteworthy. See also Fowler's *Locke* ('English Men of Letters,' 1880), and the present writer's *Locke* (1890), and his critical edition of the *Essay* (2 vols. 1894).

Lockerbie, a market town, with a great August lamb-fair, in Annandale, Dumfriesshire, 15 miles ENE. of Dumfries and 26 NW. of Carlisle. Pop. 2391.

Locker-Lampson, FREDERICK, son of a naval officer, was born in 1821, served some years as précis writer in the Admiralty office, and made his name widely known as a writer of unusually bright and clever *vers de société*, by his *London Lucies* (1857), collected from the various papers in which they had appeared. Later books are *Late Elizabethan* (1867) and *Parliament* (1879). In 1859 he married a daughter of the seventh Earl of Elgin, who died in 1872; and in 1874 the daughter of Sir Curtis Lampson, when Locker added the name of Lampson to his own. In 1878 his daughter was married to Lionel Tennyson. He died 30th May 1895. See *My Confessions* (1896), which is an autobiography.

Lockhart, JOHN GIBSON, was born in Cambusnethan manse, near Wishaw, 14th July 1794. All his boyhood was spent in Glasgow, where at eleven he passed from the high school to the college, and whence at thirteen, with a Balliol Snell exhibition, he went up to Oxford. In 1813 he took a first class in classics; then, after a visit to the Continent (to Goethe at Weimar), studied law at Edinburgh, and in 1816 was called to the Scottish bar. But he was no speaker; and having while still at Oxford written the article 'Heraldry' for the *Edinburgh Encyclopædia*, and soon after translated Schlegel's *Lectures on the History of Literature*, from 1817 he took more and more to literature, and with Wilson became the chief mainstay of *Baldwin's Magazine*. In its pages he first exhibited the sharp and caustic

wit, his most salient characteristic, that made him the terror of his Whig opponents. *Peter's Letters to his Kinsfolk* (2d ed., 1819), a clever skit on Scottish society, was followed by four novels - *Valerius* (1821), a romance of the times of Trajan; *Adam Blair* (1822); *Reginald Dalton* (1823), a tale of university life; and *Matthew Wald* (1824). Of these *Adam Blair* alone retains its vitality - the strong, sad story of a good man's fall and repentance; Henry James has likened it to Hawthorne's *Scarlet Letter*. The spirited *Ancient Spanish Ballads* appeared in 1823; *Lives of Burns and Napoleon* in 1828 and 1829; and the *Life of Scott*, Lockhart's masterpiece, in 1837-38. He had met Scott first in May 1818, in April 1820 had married his eldest daughter, Sophia, and for five and a half years had divided his time pretty equally between Edinburgh and Chiefswold, near Abbot-ford. In 1825 he removed to London to assume the editorship of the *Quarterly Review*, at a salary of £1 00 per annum; and this post he retained till 1833, in 1843 becoming also auditor of the duchy of Cornwall, a sinecure worth £400 a year. But his closing years were clouded by illness and deep depression; by the secession to Rome of his only daughter, with her husband, Mr Hope-Scott (q.v.); and by the loss of his wife in 1837, of his two boys in 1831 and 1833. The elder of them was the 'Hugh Littlejohn' of Scott's *Tales of a Grandfather*; the younger, Walter, was a scapegrace in the army. Like Scott, Lockhart visited Italy in search of health; like Scott, he came back to Abbot-ford to die - 25th November 1854. He is buried in Dryburgh at Sir Walter's feet. See his *Life and Letters*, by Andrew Lang (1896).

Lock Haven, capital of Clinton county, Pennsylvania, is situated in a beautiful mountain valley, on the south bank of the West Branch of the Susquehanna River (here crossed by a bridge), and on the West Branch Canal, 69 miles N.E. of Altoona by rail. It contains a state normal school, large foundries and tanneries, machine-shops and mills, and has an active trade in lumber. Pop. 7345.

Lock Hospital, in London, for female contagious diseases, was founded in 1746, the chapel in 1764, and the asylum in 1787. The Loke or Lock, in Southwark, from which it derives its name, was an ancient leazar-house, and was itself perhaps so-called from Fr. *loquet*, 'rags' or 'lint.'

Lock-jaw. See TETANUS.

Lockport, capital of Niagara county, New York, on the Erie Canal, 25 miles N.N.E. of Buffalo by rail. The canal here passes through a deep channel, several miles long, cut in the solid limestone, and falls 66 feet, by ten combined double-locks. Its surplus water drives a number of lumber, flour, and woollen and cotton mills, besides other factories, foundries, machine-shops, &c. Pop. (1880) 13,522; (1890) 16,038.

Lockyer, SIR JOSEPH NORMAN, K.C.B. (since 1897), was born at Rugby on 17th May 1836, and in 1857 became a clerk in the War Office, being subsequently transferred to the Science and Art Department. In 1869 he was elected an F.R.S., and in 1870 was appointed secretary to the Royal Commission on Scientific Instruction, made lecturer on Astronomy at the Normal School of Science at South Kensington, and sent out to Sicily as head of the eclipse-expedition. In the following year he headed a similar expedition to India and was elected Rede lecturer at Cambridge. He had already in 1866 discovered a new method of observing the sun; and in 1874 he gained the Rumford medal of the Royal Society, and was appointed editor of *Nature*. He is an able popular lecturer on astronomical physics, and has written *Elementary Lessons in*

Astronomy (1868), *Studies in Spectrum Analysis* (1878), *Contributions to Solar Physics* (1873), *The Spectroscope and its Applications* (1873), a primer on *Astronomy* (1875), *Star-Gazing* (1878), and *Chemistry of the Sun* (1887). In 1888 he was Bakerian lecturer.

Loche, a Swiss town, 10 miles N.W. of Neuchâtel, is one of the chief seats of the Swiss watch-making industry. Pop. 10,464.

Locomotion. See FLYING, HORSE, &c.

Locomotives. See STEAM ENGINE and RAILWAY.

Locomotor Ataxia, or TABES DORSALIS, is a remarkable disease of the nervous system, the most characteristic symptom of which is a want of power of co-ordinating the muscles. The lower limbs are almost always first and most severely affected, and the patient walks with a peculiar gait; he lifts the feet high and brings them down with a stamp; he has difficulty in balancing himself; and though he may be able to walk pretty well in a straight line on level ground, any more complicated movement (turning round, surmounting or avoiding obstacles, &c.) much increases his unsteadiness. When deprived of the aid of sight (in the dark, or on closing the eyes) these difficulties are much aggravated. In the great majority of cases sensation is early affected; and he may complain that he always feels as if he were walking upon a thick carpet. The power of the muscles is in many cases quite unimpaired.

Besides the symptoms of incoordination, and often long preceding them, are others, some of which are so characteristic that they may lead to the recognition of the disease. Severe shooting pains, especially in the lower limbs (called *lightning pains*), are frequent. Similar pains in the region of the stomach, associated with vomiting, faintness, &c. (*gastric crises*); paralysis, often transient, of one of the eye-muscles; extreme contraction of the pupil; atrophy of the optic nerve; a peculiar form of inflammation of one or more joints, are all met with in a certain proportion of cases.

The progress of the disease is always slow and uncertain; it may generally be measured by years, often by decades; but, although in some cases the condition of the patient may remain stationary for years, it generally becomes gradually worse. Death usually results from some intercurrent disease. Locomotor ataxia generally begins between the ages of thirty and fifty, and is much more common in the male sex. It seems sometimes traceable to severe acute illness, to chill, over-fatigue, injury, &c., and many of those who suffer from it have previously had syphilis; but in a large number of cases no cause is discoverable.

After death a fibrous degeneration (sclerosis) of the whole or part of the posterior columns of the spinal cord is found. The extremely uncertain course of the disease renders it very difficult to be certain of the effect of treatment, though many different methods have been advocated, and asserted to produce amendment if not cure. The most hopeful cases are those which follow syphilis; for in them a prolonged anti-syphilitic treatment not unfrequently seems to lead to great improvement or even disappearance of the symptoms.

Locri, a people of ancient Greece, divided into two distinct tribes, differing in customs and civilisation. The one, known as Locri Epicnemidii and Opuntii, dwelt on the mainland over against the island of Eubœa, whilst the other, called Locri Ozolæ, lived on the northern shore of the Gulf of Corinth. The chief town of the eastern Locri was Opus, of the western Amphissa. A colony from one or the other of these tribes founded *circa* 710 B.C. in South Italy the celebrated city of Locri,

which stood near the southern extremity of the Britian peninsula. Loeri was generally in opposition to Rome, first as the ally of the Syracusans, then of the Carthaginians. Excavations were carried out here in 1889-90.

Locus, in Geometry, denotes the line or surface traversed by a point which is constrained to move in accordance with certain determinate conditions. Thus, the locus of a point which must always preserve the same uniform distance from a fixed point is the surface of a sphere; but if the motion be at the same time confined to a plane, the locus then will be a circle; this is an illustration of the division into *solid* and *plane* loci which prevailed among the ancients. In modern Geometry plane loci are treated under the name of Curves (q.v.).

Locust, a name applied to the members of a family (Acrididae) of orthopteron insects nearly related to grasshoppers. It is unfortunate that the family Locustidae and the genus *Locusta* do not include what are usually called locusts, but the related grasshoppers, katydids, &c. Locusts in the popular sense, members of the family Acrididae, are large, ground-loving insects, of world-wide distribution, famous for their voracious vegetarian appetite. In size they vary from $\frac{1}{4}$ inch to 5 inches in length. They have strong hind-legs with great leaping powers, large heads with formidable mouth-organs, shorter antennae and robuster bodies than grasshoppers. Both winged and wingless forms occur, the former with strong powers of flight, though they are doubtless aided in traversing seas and continents by the prevailing winds. The females have strong ovipositors by which they bore holes for their eggs; the males are without the grasshoppers' stridulating organ at the base of the wings, but rub their thighs against the edges of the wing covers. The numerous eggs are hid in holes drilled in the ground; the young develop with incomplete metamorphosis, and when hatched generally resemble the parents except in the absence of wings. From the first they are gregarious, and excessively voracious except during their repeated moults; they devour all green things, and even one another, and are often forced by stress of hunger and excessive multiplication to migrate in great swarms, 'which have been traced over a stretch of country many hundreds of miles in length.' They periodically appear in destructive hordes, 'thick as snow-flakes,' darkening the sky in 'myriads numberless, the rushing of whose wings is as the sound of a broad river.' Their ceaselessly moving jaws make a noise comparable to a spreading flame or to 'chaufours in battle;' in a few hours cornfields are reduced to bare stalks or stubble; 'the land is as the garden of Eden before them, and behind them a desolate wilderness.' The prophet Joel's description is at once vivid and accurate. Their ravages sometimes cause widespread famine and ruin; their rotting corpses produce pestilential effluvia. In many countries they are eaten, roasted or fried in butter, preserved in brine, plain boiled, or dried in the sun. 'In taste the red locust, which is the female, resembles green wheat, having a very delicate vegetable flavour.' One of the most famous and destructive forms is the Rocky Mountain Locust, *Calyptenus spectus*; the most abundant migratory species of the East, so often mentioned in the Scriptures, is *Pachytelus maculicornis*, Acridium, Oedipoda, Stenobothrus are among the

numerous other genera of importance. See GRASS-HOPPLER; and for a complete account of the Rocky Mountain Locust, see C. V. RILEY in Reports of United States Entomological Commission (Washington, 1877-87). For the 'seventeen years' locust or harvest fly of North America, see CICADA.

Locust Destruction. Numerous systems both in the Old and the New World have been adopted for destroying these terrible swarms. They were beaten down as they flew; they were pushed into bags as they crawled, and their eggs were collected and burned on a very large scale before the young were hatched. A bounty has been offered for their destruction, in Minnesota, for instance, so much a bushel being paid, and thousands of bushels brought in. But no method was of any practical avail, until in Cyprus, under British administration, a system was perfected which has been so completely successful that it may be said to be the only one worthy of notice or consideration. It was suggested as early as 1870 by an enterprising land owner in Cyprus, Mr Richard Mattei, and was modified and perfected by Mr Samuel Brown,

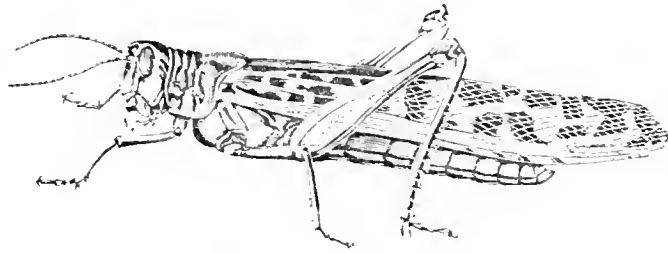

Locust *Pachytelus maculicornis*

government engineer-in-chief in the island in 1881. Mr Mattei was created a C.M.G. in 1886.

By his system, based upon a close observation of the nature and habits of the insects during many years, the locusts are caught while they are 'on the march'—that is to say, while (some ten days after they are hatched) they march across the country in countless hosts or 'armies.' Mr Mattei, having observed that no obstacle causes them to turn back in their onward progress, but that they climb and crawl over everything that bars their direct course, and that furthermore they are unable to obtain foothold on any perfectly smooth or polished surface, hit upon the ingenious expedient of barring their progress by means of long canvas screens put up on stakes and furnished at the top with a band of varnished leather or what is called American cloth. Deep pits are dug at intervals of some few yards on the side of these screens facing the advancing hosts, and the locusts, reaching the obstacle and being unable to surmount it owing to the polished surface on the upper edge, fall down and are caught in the pits, which are themselves edged and lined to a depth of a few inches with polished zinc. Finally, the locusts as they fall into the pits are rendered ineffectual by crawling out, not only by the smooth surface of the zinc, but by the superincumbent weight of the tens of thousands of fresh victims that are perpetually piling in upon them. By this system the locusts in Cyprus were in five years entirely destroyed, and at a cost, though large for Cyprus, certainly not excessive, amounting to less than £13,000 a year. But the magnitude of the operations conducted for this comparatively moderate sum of money may be gathered from the statement that there were employed over half a million yards of canvas-screen, and thirteen thousand zinc traps, with stakes, tools, and tents for the men engaged,

in proportion. Locusts were trapped (in 1883) in about 26,000 pits, and a far larger number of holes were actually dug; while a special staff of no less than 2621 persons was employed during the campaign. Nor was the destruction on a scale incommensurate with these immense preparations. The number of the slain in 1883 is estimated, after careful calculation by Mr. Brown, as being nearly 200,000,000,000, with an expenditure of only £12,300. And in the following year the enemy still remained sufficiently numerous to supply a list of casualties numbering over 56,000,000,000 locusts. Taking these numbers together at, say, 250,000,000,000 for the two years 1883 and 1884, and the expenditure during the same period at £27,500, we find the cost of slaying locusts has been 2s. a million, which is perhaps as economical a slaughter of living creatures as is recorded in the history of nature or art. Locust destruction on this system was only commenced in 1881, and in 1886 there were few if any locusts in Cyprus left to be destroyed. See the *National Review* for March 1888.

Locust-tree, a name given in different parts of the world to different trees of the natural order Leguminosæ. The Carob tree (*Ceratonia siliqua*) is often so called in the countries bordering on the Mediterranean, and its pods are the locust-beans of our shops (see CAROB). The Locust tree of America (*Robinia pseudo-acacia*), also called the False Acacia, or Thorn-acacia, and on the continent of Europe and in Britain very generally the Acacia, is a valuable and extremely beautiful tree (see ROBINIA). The wood, known as *Locust-wood*, is useful for all purposes in which great strength, and especially toughness, is required; 'locust,' indeed, is the slang term in the United States for a policeman's baton. The Honey Locust-tree (q.v.) of America is a *Gleditsia*. The Locust-tree of the West Indies is *Hymenocaulis caribæol*, a gigantic tree whose pods also supply a nutritious matter, a mealy substance in which the pods are embedded. The bark of the tree is antiseptic; it yields a kind of resin called Anime (q.v.), and it is valuable as a timber tree, the timber (also known as *Locust-wood*) being close-grained and tough.

Lode, a miner's term for Veins (q.v.) in which minerals occur. See ORE-DEPOSITS.

Lodestar (lit. 'way-star,' or star that shows the course), an old name for the Pole-star (q.v.).

Lodestone. See LOADSTONE, MAGNETISM.

Lodève (anc. *Lutecæ*), a town in the French department of Hérault, at the foot of the Cevennes, 43 miles by rail N.W. of Montpellier. A bishop's see till 1790, it has a cathedral, founded in 950, but rebuilt in the 14th century. Cardinal Fleury was a native. Pop. 9225.

Lodge, EDMUND (1756-1839), successively Lancaster, Norwy, and Clarenceux herald, published *Illustrations of British History* (3 vols. 1791), a *Life of Julius Cæsar* (1810), and an annual *Portrait*; but is best known as author of the *Portraits of Illustrious Personages of Great Britain* (4 vols. fol. 1821-34), the cost of engraving and printing which exceeded £10,000.

Lodge, THOMAS, English dramatist, romance-writer, and poet, was born at West Ham about 1556. After studying at Trinity College, Oxford, he entered at Lincoln's Inn, but seems to have led a wild and rollicking life, using his pen occasionally, as in a duel with Gosson, against whom he defended stage plays in a couple of pamphlets (edited by D. Lang for the Shakespeare Society in 1853). In 1589-91 he varied his life by taking part in two sea-expeditions against the Spaniards, in the neighbourhood of the Azores and Canary Islands. On

the first of these voyages he wrote an eulphastic romance, *Rosalynde* (1590; reprinted in Hazlitt's *Shakespeare's Library*, vol. ii., and again, separately, in 1887), which supplied England's great dramatist with the chief incidents, and even more than the chief incidents, of *As You Like It*. Lodge himself wrote two second-rate dramas, *The Wounds of Civil War* (1594; reprinted in Hazlitt's Dodsley's *Select Collection of Old Plays*, vol. vii.), and *A Looking-glass for London and England* (1594), written in collaboration with Robert Greene (q.v.), another dissipated author. He was generally stated to have been a player, until the point was effectively disproved by C. M. Ingleby in 1868. But he is believed to have taken a medical degree at Avignon, and to have written a *History of the Plague* (1603). He died himself of the plague in 1625. Of his remaining writings we may mention *A Fig for Moanus* (1595; reprinted in Sir A. Boswell's *Frondeur's Calendar*, 1817); translations of Seneca (1614) and Josephus (1602); *Life of William Longshard* (1593); *History of Robin the Drevell, Wals Miseric, and Glanous and Salla* (poems, one of which suggested the plan of Shakespeare's *Veins and Adonis*, 1589). See the *Works*, edited by Gosse (4 vols. 4to, 1884).

Lodgings in another person's house constitute the relation of landlord and tenant. It is not necessary that the contract should be in writing, though it is highly expedient. In England, unless there has been part performance, a verbal contract to let lodgings cannot be enforced, since it is an agreement relating to land, and so void by the Statute of Frauds. But where a furnished house is let, and a written agreement or lease is used, it is absolutely necessary that there should be a stamp on such writing, which, if adhesive, must be cancelled by the parties under a penalty of £10. One of the risks which the lodger in England ran was that if his landlord, L, were himself a tenant to A, then, if L's rent were in arrear, the lodger's goods might be taken by A to pay this, for the rule was that all goods found on the premises (with certain definite exceptions, of which this was not one) could be taken under a distress for rent; but by the 31 and 35 Viet. chap. 79, 1871, it was provided that, if the lodger has paid the mesne (or intermediate) landlord, the superior landlord must leave his goods alone; if he has not paid the mesne landlord, then he may pay the superior landlord in lieu of the mesne landlord, and again obtain protection for his goods. The statute 2 and 3 Viet. chap. 71, sect. 38, provides that a police-magistrate may award compensation up to £15 for wilful damage done by lodgers. The Larceny Act, 1861, makes the stealing of chattels or fixtures by lodgers a felony punishable by imprisonment for two years or penal servitude for seven years, according to the value of the thing stolen.

A lodger is entitled to the use of the door-bell and knocker, and the landlord impliedly promises that the rooms are fit for occupation. In letting an unfurnished house there is no such implication. A lodging-house keeper, even where he keeps a boarding-house, which nearly resembles an Inn (q.v.), is not liable for the safe custody of the lodger's goods. He is merely liable for ordinary care; but he does not warrant at all hazards that the goods will not be stolen. Even if the lodger's goods are stolen by a servant of the house, the lodging-house keeper is not liable. The notice to quit depends on how the lodgings were taken. If they were taken by the week, a week's notice is sufficient; if by the month, a month's; and if by the quarter, a quarter's notice, unless some other agreement was made. Hence, if the lodger quits without notice, he is liable for one week's, or month's, &c. rent, even

though the landlord put a notice in the window. The lodging-house keeper may distrain the lodger's goods for unpaid rent. When a lodger refuses to quit the lodgings after a notice has expired he cannot be put out by force, but in many cases a summary remedy is given for recovering possession. Since 1868 a lodger is entitled to vote for members of parliament in boroughs, if he pays rent of the clear annual value of £10, provided also that he has resided twelve months in the district, and put in his claim to be registered. The lodger-franchise was extended to counties by the Representation of the People Act of 1884. In Scotland the lodger's goods cannot be taken by the landlord of the lodging-house keeper for rent, nor is it yet decided whether the householder's liability in case of loss of the lodger's goods is equal to or less than that of an innkeeper.

Continental Lodging-houses, where poor people lodge by the night, are subject to police supervision. The Public Health Act, 1875, provides (in continuation of earlier statutes) for their registration and inspection, and enacts that they are only to be kept by registered keepers. Before being licensed they are inspected by the medical officer of health, every room being measured and restricted to a specified number of lodgers. Every room has this number painted on the door, and a copy of the police regulations is posted up in a conspicuous part of it. The keepers are bound to thoroughly cleanse all the rooms, stairs, &c., as often as by laws shall direct, and to keep a proper supply of water. If fever break out notice must be given to the local authority. These duties are enforced by means of penalties. The same act directs that, if any person suffering from any dangerous infectious disorder has lodged in any rooms, such rooms must be disinfected to the satisfaction of a legally qualified medical practitioner, as testified by a certificate signed by him, before they are again let. Similar provisions are in force in Scotland and Ireland. Of recent years very great improvements have been effected in common lodging-houses. In most large towns in Great Britain 'model lodging-houses' have been erected on approved plans, wherein greater privacy is ensured in the sleeping quarters, and a complete system of ventilation secured. The latest inventions in cooking apparatus, washing-houses, &c. have been introduced; while reading, recreation, and bath rooms form indispensable parts of these establishments. See VAGRANTS.

Lodi, a town of North Italy, stands on the Adda, 18 miles by rail SE. of Milan. It has a Romano Gothic cathedral dating from the 12th century; manufactures of linens, silks, and Majolica porcelain; and a great trade in Parmesan and Stracchino cheese and wine. Pop. 18,689. -- **Lodi Vecchio**, a ruined village, 4 miles W., was destroyed by the Milanese in 1111-58. Here Bonaparte, on 10th May 1796, forced the long and narrow bridge in the face of a tremendous fire from the Austrian batteries.

Lodomeria (Lat. for Vladimir), formerly an independent principality in Volhynia, has, since the division of Poland in 1772, constituted an integral part of the Austrian 'kingdom of Galicia and Lodomeria.' See GALICIA.

Lodz, sometimes called 'the Manchester of Poland,' lies 76 miles SW. of Warsaw on a branch railway. It consists chiefly of one main street, 6 miles or more long, and has more than 120 manufactories making cotton and woollen stuffs. Pop. (1879) 39,978; (1881) 49,332; (1895) with enlarged boundaries, 119,309, nearly half Germans.

Loess. See BOSS.

Loewe, JOHANN CARL GOTTFRIED, composer, was born 30th November 1796, between Kothen

and Halle, the twelfth son of a schoolmaster. He became a choir-boy at Kothen, later studied music and theology at Halle, and in 1821 settled at Stettin, where he became successively professor in the gymnasium, musical director to the city, and organist. He made visits to Norway, Sweden, and France, and in 1847 sang and played before the English court in London. He died 20th April 1869. He composed five operas (of which only one, *The Three Wishes*, was performed), sixteen oratorios (several of them for voices only, without accompaniment), and numerous symphonies, concertos, duets, and other works for the pianoforte. But his ballads are his most notable bequest to posterity: they are, many of them, remarkable dramatic poems, and in some respects Loewe may claim to have done for the ballad what Wagner did for opera. Gehring, in Grove's *Dictionary* (1880), said that Loewe's 'music has gone for ever,' but more recently a good deal of attention has been called to the ballads. See *The Art Ballad, Loewe and Schubert*, by A. Bach (Edin. 1890).

Lofft, CAPLE, described by Byron in *English Bards* as 'the Mæcenas of shoemakers and preface-writer-general to distressed versemen; a kind of gratis acconcheur to those who wish to be delivered of rhyme, but do not know how to bring forth.' This description, though not the ill-nature of it, was so far just that Lofft was the patron of Bloomfield, and stood sponsor to his *Farmers' Poem*. Lofft himself was a London barrister of the Whig persuasion, with a taste for letters, especially poetry: he wrote some legal treatises and magazine articles, and books on theological, astronomical, political, and poetical subjects. All are now forgotten. He was born in London on 11th November 1751, and died at Moncalieri, near Turin, on 26th May 1824. See *Gentleman's Magazine* (1824).

Lofoden, or LOFOFEN, a chain of islands on the north-west coast of Norway, between 67° and 69° 15' N. lat., and stretching south-west and north-east for 150 miles. They include the Lofoten proper and the Vesterdaalen, lying farther north. The largest islands are Hind, And, and Lang in the Vesterdaalen group, and East Vaag, West Vaag, Flakstad, and Moskenas in the Lofoten proper. Total area, 2247 sq. m. All of them are rugged and mountainous, many of the summits being crater-shaped. In several places they present walls of bare rock rising sheer from the ocean. The highest point is 3090 feet above sea-level. The waters on the east side of these islands are visited in January to March every year by vast shoals of cod fish, which attract a large fleet of fishermen. The average number of boats is 5000 to 6000, manned by 28,000 to 30,000 men; and the produce of the fishery is about 30,000,000 fish, 24,000 barrels of cod-liver oil, and 25,000 to 26,000 barrels of roe. The fishing is attended with considerable danger, on account of the sudden and violent storms from the west, and of the strong currents which set in between the islands (see MAELSTRÖM). Besides fishing, sheep-farming is also carried on, as, owing to the influence of the Gulf Stream, the winters are mild and grass grows abundantly. The permanent population number about 20,000.

Log is the instrument by which a ship's rate of motion through the water is measured. In its oldest and simplest form it is a quadrantal piece of teak wood called a log-ship, loaded in the air so as to float vertically, point upwards. Every hour or two hours it is hove overboard for twenty-eight seconds, or, if the ship is going very fast, for fourteen seconds. It is attached to a line called the log-line. The supposition is that when hove into the sea it will remain stationary in the water while

The log-line is freely paid out from a reel held by hand on board. In actual practice a conical canvas bag, called a log bag, with its open mouth facing the vessel, is often used instead of the log-ship. The log-line, which is attached to the log-ship or to the log bag, is divided into equal sections by pieces of marline which are tucked through its strands, each section being that part of a geographical mile which twenty-eight seconds is of an hour, so that the number of sections of the log-line which run out during twenty-eight seconds is the same as the number of geographical miles which the ship is going per hour at the time of testing the speed. To facilitate counting the number of sections of the log-line which have been paid out, one, two, three, &c. *Knots* (q.v.) are tied on the

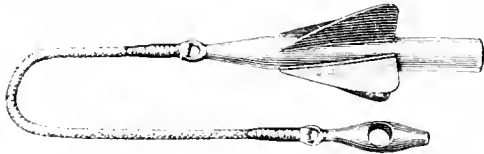

Fig. 1.—Rotator with four vanes.

tails of the pieces of marline. In practice, each section is made 46 feet 8 inches long, which is designedly rather shorter than the theoretical length.

A ship's progress through the water is, however, much more generally obtained, especially near land, by towing continuously a small cylindrical tube to which are attached oblique vanes, usually four in number. This rotator, as it is called, revolves as it is towed with a speed which is proportional to the speed of the vessel. This proportion is ascertained by experiment by the makers, and a registering apparatus, consisting of the usual cog-wheels and pinions, records the revolutions of the rotator, and so records the progress of the ship. In the older form of this log the registering gear is

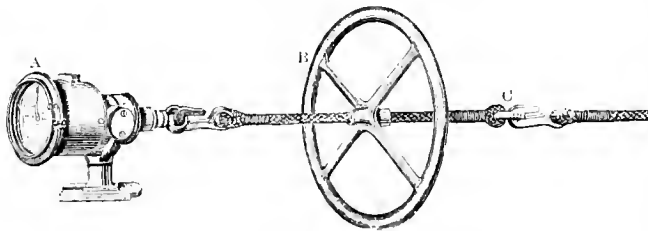

Fig. 2.—Log Register (A), with governing fly-wheel (B) attached, the tow-line being hooked on at C.

attached directly to the rotator, and is towed with it through the water. The progress of the ship can in this case only be ascertained by hauling the log on board. In the newest forms the rotator alone is in the water. The registering gear is contained in a small case which is secured to the taffrail of the ship, or to an outrigger, so that it can be conveniently read at any moment, the revolutions of the submerged rotator being transmitted to the taffrail register by the tow-line which also rotates. A fly wheel or rotating triangle or dumb-bells are placed on the tow-line between the rotator and the register, but close to the register, to secure greater smoothness in the working of the latter. The registering dial is usually graduated to knots (nautical miles) up to 100, and a smaller dial gives subdivisions of a quarter of a nautical mile. An automatic bell rings at every mile. But even under the most favourable circumstances a navigator is

not justified in regarding any form of log as an instrument of precision.

Log-book.—The courses steered, distances run, wind, state of the weather and sea, leeway, daily employment of the crew, and other incidents, which in the first instance are noted at the moment in the bridge-book or deck-book, are daily entered in the log-book, which thus becomes the diary of the ship.

Official Log-book.—The official log-book is a book issued by the Board of Trade at the beginning and returned to that department at the end of each voyage. It contains a record of the crew and their characters, ship's draught of water, offences committed, desertions, sickness, deaths, medical treatment, collisions, &c., and is thus a sort of civil or police record of the voyage.

Logan, JOHN, poet and sermon-writer, was born at Sontra, in Midlothian, in 1748. His father was a small farmer, but was able to send his son to college. In 1773 he was licensed as a preacher, and from his eloquence and fervour in the pulpit soon became so popular that he was chosen minister of the second charge of South Leith parish that same year. In 1786, however, owing to intemperate habits, and for kindred reasons, he was constrained to resign his charge, after which he proceeded to London, and there engaged in literary work. He died there, December 28, 1788. Besides two volumes of sermons and lectures which were published after his death, he was the author of a tragedy called *Kennilode*, but this, after a single performance at the Edinburgh Theatre, was withdrawn from the stage. In 1781 he published a volume of poems, which, though coldly received in critical circles, speedily reached a second edition. His name is best known now in connection with that of Michael Bruce and the controverted authorship of the 'Ode to the Cuckoo' and certain of the Paraphrases. The most effective statement in behalf of Logan's claims which has yet appeared will be found in two papers by the Rev. Robert Small, Edinburgh, which were published in the *British and Foreign Evangelical Review* for 1879. That Logan is entitled to a place among the minor poets of Scotland is sufficiently attested, though there were nothing more, by his exquisite lyric, 'The Braes of Yarrow.'

Logan, JOHN ALEXANDER, an American statesman, was born in Illinois, the son of an Irish doctor there, in 1826. He served in the Mexican war, was admitted to the bar in 1852, and was elected to congress as a Democrat in 1858. He raised an Illinois regiment at the beginning of the civil war, and served with credit to the last battle, retiring with the rank of major-general. In 1866 he was returned to congress as a Republican, and was one of the managers of the impeachment of President Johnston. He was chosen a United States senator in 1871, and was returned to the senate in 1879 and in 1885. In 1881 he was nominated by the Republicans for the vice-presidency of the United States, but was defeated along with James G. Blaine (q.v.). He died in Washington, 26th December 1886. There is a Life by G. F. Dawson (Chicago, 1887).

Logan, SIR WILLIAM EDMOND, geologist, was born, a Scotch baker's son, at Montreal, in Canada, on 20th April 1798, and in 1814 was sent over to Edinburgh High School. For ten years he worked in a commercial counting-house in London, and was then, about 1828, sent to Swansea to take charge of the finances of a copper-smelting

company. Whilst living in South Wales he prepared geological maps of the coal basins in that part of the country, and his work was so well done that it was incorporated in the 1-inch maps of the Geological Survey. In 1842-71 Logan was director of the Canadian Geological Survey. He was the discoverer of the Stigmairia underclays and of the *Eozoon Canadense* (q.v.). He was knighted in 1856, and died in Wales, 22d June 1875. See the *Life* by Harrington (1883).

Logan. See ROCKING-STONE.

Loganiaceæ, a natural order of corollifloral exogens, consisting of trees, shrubs, and herbaceous plants, with opposite entire leaves, and usually with stipules, which adhere to the footstalks, or form sheaths. A few species of this order occur in Australia and in the temperate parts of North America; the rest are all tropical or subtropical. No natural order of plants is more strongly characterised by poisonous properties. It includes the genus *Strychnos* (q.v.; and see *NUX VOMICA*) and the Curai Poison (q.v.). See also SPIGELIA.

Logansport, capital of Cass county, Indiana, is 75 miles N. by W. of Indianapolis, at the crossing of three railroads, where the Eel River joins the Wabash. There are extensive railway-shops, besides flour and lumber mills and foundries; and the town has a large shipping trade in grain, pork, &c. Pop. (1880) 11,198; (1890) 13,328.

Logarithms, a series of numbers having a certain relation to the series of natural numbers, by means of which many arithmetical operations are made comparatively easy. The nature of the relation will be understood by considering two simple series such as the following, one proceeding from unity in geometrical progression, the other from 0 in arithmetical progression:

Geom. series, 1, 2, 4, 8, 16, 32, 64, 128, 256, 512, &c.

Arith. series, 0, 1, 2, 3, 4, 5, 6, 7, 8, 9, &c.

Here the ratio of the geometrical series is 2, and any term in the arithmetical series expresses how often 2 has been multiplied into 1 to produce the corresponding term of the geometrical series; thus, in proceeding from 1 to 32, there have been 5 steps or multiplications by the ratio 2; in other words, the ratio of 32 to 1 is compounded five times of the ratio of 2 to 1. It was this conception of the relation that led to giving the name of *Logarithms* to the terms of the arithmetical series, the word *logarithm* (Gr. *logon arithmos*) meaning 'the number of the ratios.' As to the use that may be made of such series, it will be observed that the sum of any two logarithms (as we shall now call the terms of the lower series) is the logarithm of their product—e.g. 9 (= 3 + 6) is the logarithm of 512 (= 8 × 64). Similarly, the difference of any two logarithms is the logarithm of the quotient of the numbers; a multiple of any logarithm is the logarithm of the corresponding number raised to the power of the multiple—e.g. 8 (= 4 × 2) is the logarithm of 256 (= 16²), and a submultiple of a logarithm is the logarithm of the corresponding root of its number. In this way, with complete tables of numbers, and their corresponding logarithms, addition is made to take the place of multiplication, subtraction of division, multiplication of involution, and division of evolution.

In order to make the series above given of practical use, it would be necessary to complete them by interpolating a set of means between the several terms, as will be explained below. We have chosen 2 as the fundamental ratio, or base, as being most convenient for illustration; but any other number (integral or fractional) might be taken; and every different base, or *radix*, gives a different system of logarithms. The system now in use has 10 for its

base; in other words, 10 is the number whose logarithm is 1.

The idea of making use of series in this way would seem to have been known to Archimedes and Euclid, without, however, resulting in any practical scheme; but by the end of the 16th century trigonometrical operations had become so complicated that the wits of several mathematicians were at work to devise means of shortening them. The real invention of logarithms is now universally ascribed to John Napier (q.v.), Baron of Merchiston, who in 1614 printed his *Canon Mirabilis Logarithmorum*. His tables only give logarithms of sines, cosines, and the other functions of angles; they also labour under the three defects of being sometimes + and sometimes -, of decreasing as the corresponding natural numbers increase, and of having for their *radix* (the number of which the logarithm is 1) the number which is the sum of $1 + 1 + \frac{1}{1.2} + \frac{1}{1.2.3} + \dots$, &c. In many calculations, however, the latter is an advantage rather than a defect. These defects were, however, soon remedied; John Speidell in 1619 amended the tables in such a manner that the logarithms became all positive, and increased along with their corresponding natural numbers. He also, in the sixth edition of his work (1624), constructed a table of Napier's logarithms for the integer numbers, 1, 2, 3, &c., up to 1000, with their differences and arithmetical complements, besides other improvements. Speidell's tables are now known as *hyperbolic logarithms*. But the greatest improvement was made in 1615, by Professor Henry Briggs (q.v.), of London, who substituted for Napier's inconvenient 'radix' the number 10, and succeeded before his death in calculating the logarithms of 30,000 natural numbers to the new radix. Briggs's exertions were ably seconded; and before 1628 the logarithms of all the natural numbers up to 100,000 had been computed. Computers have since chiefly occupied themselves rather in repeatedly revising the tables already calculated than in extending them.

Construction of Tables.—The following is the simplest method of constructing a table of logarithms on Briggs's system. The log. of 10 = 1; the log. of 100 (which is twice compounded of 10) = 2; the log. of 1000 = 3, &c.; and the logarithms of all powers of 10 can be found in the same manner. The intermediate logarithms are found by continually computing geometric means between two numbers, one greater and the other less than the number required. Thus, to find the log. of 5, take the geometric mean between 1 and 10, or 3.162..., the corresponding arithmetic mean (the log. of 1 being 0, and that of 10 being 1) being 0.5; the geometric mean between 3.162... and 10, or 5.623..., corresponds to the arithmetic mean between 0.5 and 1 or 0.75; the geometric mean between 3.162... and 5.623..., or 4.216..., has its logarithm = $\frac{1}{2}(0.75 + 0.5)$ or 0.625; this operation is continued till the result is obtained to the necessary degree of accuracy. In this example the twenty-first result gives the geometric mean = 5.000,003, and the corresponding arithmetic mean = 0.698,970, which is in ordinary calculations used as the logarithm of 5. Since division of numbers corresponds to subtraction of logarithms, and since $2 = \frac{10}{5}$, the log. of 2 = log. 10 - log. 5 = 1 - 0.698970 = 0.301030. The logarithms of all prime numbers are found in the same way as that of 5; those of composite numbers are obtained by the addition of the logarithms of their factors; thus the log. of 6 = log. 2 + log. 3 = 0.301030 + 0.477121 = 0.778151. This method, though simple in principle, involves an enormous amount of calculation; and the following method, which depends on the modern algebraic analysis, is much to be

preferred. According to this method, logarithms are considered as indices or powers of the radix; thus, $10^0 = 1$, $10^0 \cdot 301030 = 2$, $10^0 \cdot 477121 = 3$, $10^2 = 100$, &c.; and the laws of logarithms then become the same as those of indices. Let r represent the radix, y the natural number, x its logarithm; then $y = r^x$, or, putting $1 + a$ for r , $y = (1 + a)^x$; and it is shown by the binomial and exponential theorems (see the ordinary works on Algebra) that $y = 1 + \mu x + \frac{\mu^2 x^2}{1 \cdot 2} + \frac{\mu^3 x^3}{1 \cdot 2 \cdot 3} + \&c.$, where $\mu = r - 1 - \frac{1}{2}(r - 1)^2 + \frac{1}{6}(r - 1)^3 - \&c.$, the former equation expressing a number as the sum of different multiples of its logarithm and the radix. If $1/\mu$ be substituted for x , then $y = 1 + \frac{1}{1 \cdot 2} + \frac{1}{1 \cdot 2 \cdot 3} + \&c. = 2.71828182$, which, as before mentioned, is Napier's radix, and is generally called e . Hence $r = e^{\mu}$, or μ is the logarithm of r to the base or radix e . Then, referring to the above-mentioned value of μ , we have $\log_e r$ (i.e. log. of r to the base e) $= r - 1 - \frac{1}{2}(r - 1)^2 + \frac{1}{6}(r - 1)^3 - \&c.$, or, as before, putting $1 + a$ for r , $\log_e (1 + a) = a - a^2/2 + a^3/3 - \&c.$; a series from which $\log_e (1 + a)$ cannot be found, unless a be a proper fraction. But if we put $-a$ for a , $\log_e (1 - a) = -a - a^2/2 - a^3/3 - \&c.$; and, subtracting this expression from the former, $\log_e (1 + a) - \log_e (1 - a)$ or $\log_e \frac{1 + a}{1 - a} = 2a + a^3/3 + a^5/5 + \&c.$; and, for the sake of convenience, putting $(a + 1)/a$ for $(1 + a)/(1 - a)$, in which case $a = 1/(2a + 1)$, we finally obtain $\log_e \frac{a + 1}{a} = 2 \frac{1}{2a + 1} + \frac{1}{3} \frac{1}{(2a + 1)^3} + \frac{1}{5} \frac{1}{(2a + 1)^5} + \&c.$; or $\log_e \frac{a + 1}{a} = \log_e a + 2 \frac{1}{2a + 1} + \frac{1}{3} \frac{1}{(2a + 1)^3} + \frac{1}{5} \frac{1}{(2a + 1)^5} + \&c.$. If 1 be put for a in this formula, the Napierian logarithm of 2 is at once obtained to any degree of accuracy required; if 2 be put for a , the Napierian logarithm of 3 can be calculated, &c. Now, as logarithms of any system have always the same ratio to one another as the corresponding logarithms of any other system, no matter what its base, if a number can be found, which, when multiplied into the logarithm of a certain number to one base, gives the logarithm of the same number to another base, this multiplier will, when multiplied into any logarithm to the first base, produce the corresponding logarithm to the other base. The multiplier is called the modulus, and, for the conversion of Napierian into common or Briggs's logarithms, is equal to 0.4342944...; so that, to find the common logarithm of any number, first find the Napierian logarithm, and multiply it by 0.4342944.

As in Briggs's system the logarithm of 10 is 1, and that of 100 is 2, it follows that all numbers between 10 and 100 have for their logarithms unity + a proper fraction; in other words, the integer portion of the logarithms of all numbers of two figures is unity; similarly, the integer portion of the logarithms of numbers between 100 and 1000 is 2, and, in general, the integer portion of the logarithm of any number expresses a number less by unity than the number of figures in that number. This integer is called the *characteristic*, the decimal portion being the *mantissa*.

As the logarithm of 1 = 0, the logarithms of quantities less than unity would naturally be negative; thus, the logarithm of $\frac{1}{2}$ would be -0.30103. But, for convenience in working, the mantissa is kept always positive, and the negative sign only affects the characteristic; the logarithm of $\frac{1}{2}$ or 0.5 would thus be 4.69897, the characteristic in this and similar cases expressing, when the fraction is reduced to a decimal, the number of places the first figure is removed from the decimal point; thus, the logarithm of 0.0005 is 4.69897.

Directions for the use of logarithms in calculation will be found prefixed to any set of mathematical tables.

The tables most distinguished for accuracy are the French ones of Callet, Lalande, Bagays; Hutton's, those which Babbage produced with the aid of his calculating machine, Shortrede's, and Sang's; and the German ones of Gauss, Schron, Bruhns, Von Vega, Bremker. A serviceable handbook is *Chambers's Mathematical Tables*, edited by Pryde.

Loggia, an Italian word signifying an open arcade, enclosing a passage or open apartment. It is a favourite class of building in Italy and other warm countries. The Loggiade' Lanzi at Florence is one of the finest examples extant; and the Loggie of the Vatican, which are arcaded passages round the interior of the cortile of the palace, ornamented with beautiful paintings and arabesques by Raphael and his pupils, are well-known specimens.

Logic may be most briefly defined, in accordance with the etymology of the word, as the science of reasoning or 'the art of thinking.' It is a scientific account of the laws which regulate the passage in thought from one statement to another, and which must be observed if the thinking process is to be valid. The theory of every operation is later than its performance, and men were accustomed to think correctly long before they began to reflect upon their thinking faculties and the processes by which their results were reached. The attention which Socrates devoted to the meaning and justification of general names is signalled by Aristotle as the beginning of logical theory. It was Aristotle himself, however, who first elaborated the idea of the science, and defined its sphere by separating it from the metaphysical questions with which logical discussions are always associated in his predecessors. The six treatises afterwards collected under the name of the *Organon* contain the gist of what is still taught as formal logic; but the term logic was probably first used by the Stoics in the wide sense with which we are familiar. Aristotle himself possessed no single name for the science of which he was the founder.

The independence which Aristotle conferred upon the new science has enabled it to survive to the present day almost without change, and with very few additions of importance. But, while the edifice of Aristotle remains architectonically complete upon its own basis, it has become customary to add to this science of logic proper a second part, called Mixed, Material, or Inductive Logic, embracing an account of the methods of science and the conditions of scientific proof. The modern version of the Aristotelian Logic is then called, by way of distinction, Pure or Formal Logic. The meaning of this designation is that logic, as such, takes no account of the *matter* of our reasonings—i.e. of the things reasoned about; it deals solely with the *form* or skeleton of the reasoning process itself. Thus, if we say, 'Englishmen are white-skinned,' logic has no occasion to consider the truth of this statement as a matter of fact or science; it deals only with the form of the proposition or judgment as a general logical mould into which any pair of notions may be fitted. It treats the proposition, in short, only so far as it is expressible in the form, 'X is Y.' To this abstraction from all questions regarding the adequacy of our notions, and the material truth of our assertions, formal logic owes its completeness as a science. It looks upon thought, not as the expression of the truth of things, but as a series of mechanical operations, and its aim is to lay down the general or symbolic forms which these operations must assume in order to insure that the end shall be consistent with the beginning. It is apparent, then, that in any reasoning process formal logic only guarantees that the conclusion

is true *if* the premises from which we started were true. It has accordingly been called the logic of consistency, as opposed to induction, which seeks to be a logic of truth. Pure logic takes its material, as it were, ready-made from the hands of observation, and merely watches over its correct manipulation. Reasoning in the strict logical sense is, in fact, merely analytic; the conclusion only brings to explicit consciousness what was implied or involved in the premises. Formal logic is thus, in its most general aspect, an application, by means of many subordinate rules, of the laws of identity and non-contradiction. Practically, however, it is of great service in clarifying the thought of the individual, though, in a sense, merely teaching him what he knows already.

Formal logic is usually treated under the three heads of Notions, Judgments, and Reasonings; or, if regard be had to the verbal expression of thought, the Notion, Judgment, and Reasoning appear respectively as Term, Proposition, and Syllogism. Though pure logic has strictly nothing to say about the formation of general names or the adequacy of our notions, it is customary for logical writers to expound under the first head the nature of generalisation and definition—the processes by which our notions are formed and tested. The Judgment, however, may be taken as the unit in logic, for it is only in their relation as subject and predicate of a judgment that notions become susceptible of logical treatment. The combination of two judgments (involving three notions), in such a form that a third judgment is deduced from them, constitutes a Syllogism—e.g. 'All fishes are cold-blooded. The whale is not cold-blooded. Therefore the whale is not a fish.' The variations of this fundamental type of reasoning constitute the scholastic doctrine of the moods and figures of the Syllogism. As an appendix to this exposition of the normal forms of inference there follows a discussion of the different classes of fallacies to which any deviation from them may give rise. It is in this aspect that logic vindicates its claim to be 'a cathartic of the human mind.' For, like ethics, logic is a normative science; that is to say, it does not, like the physical sciences, or like psychology, simply generalise facts. Its laws are not statements of what always happens, but rules of what ought to be done. This distinction contains the answer to the question, once much debated, whether logic is a science or an art. The question is essentially a dispute about words.

The perception that pure logic treats thought simply as a process of comparison and classification has induced a number of recent logicians (chiefly English) to attempt an extension of Aristotle's scheme by a thorough-going application of the notion of logical quantity. Thus, Sir W. Hamilton maintained that the relation between subject and predicate in a proposition is that of logical equation. The proposition, 'All men are mortal,' means, when fully expressed, 'All men are some mortals.' If the predicate be thus explicitly quantified, it is evident that we may substitute for the copula the algebraical symbol of equation. This doctrine, which is known as the Quantification of the Predicate, was expounded by Archbishop Thomson, Spencer Baynes, and others. It leads to a multiplication of the old propositional and syllogistic forms, but in its Hamiltonian form it has been shown by Venn to rest on a confusion of views. A similar line of thought has been worked out by Jevons, who defines inference as 'the substitution of similars.' He would make the proposition run 'All men are mortal men' (*All a is ab*). De Morgan's formula for the proposition resembles this; but his innovations, as well as Boole's development of logic into a branch of

mathematics, are rather specimens of the ingenuity of their authors than transcripts of actual thought processes. They show no signs of taking their place as a permanent addition to logical doctrine. The same may be said of Jevons' Method of Indirect Inference, by which he claims to have reached the same results as Boole without the use of mathematics. The Method consists in 'developing' all the possible combinations of the terms mentioned in the premises, and then proceeding, by elimination of those which violate the conditions there laid down, to reach those combinations which are consistent with our data. Jevons applied his principle in the invention of a logical machine which effects this process of counting out with unerring accuracy; but where the terms are multiplied to any extent the operation is, of course, cumbrous in the extreme.

Bacon is commonly regarded as the founder of Inductive Logic. In his *Novum Organum* he put himself at the head of the revolt against the scholastic logic which marked the men of the Renaissance, and, though his own apprehension of scientific method was gravely defective, his eloquence and his position made him the most influential prophet of the scientific movement which Galileo and others had initiated. In point of fact he came to supplement the old, not to supersede it; but he allowed his dislike of the abuses of the Aristotelian logic to carry him away into indiscriminate denunciation. Bacon's animus is perhaps excusable as the zeal of the reformer; and it may be granted that in the Aristotelian logic, as in Greek philosophy generally, there is a tendency to let the study of words usurp the place of the investigation of facts. The middle ages had exaggerated this tendency by habitually assuming the distinctions existing among things to be correctly and adequately rendered by traditional names. Beyond this, Bacon's diatribes against 'syllogism' betray a misapprehension of the real function of formal logic, which, as has been seen, makes no pretensions to be an instrument of scientific discovery. Inductive theory has received many developments since the time of Bacon, notably at the hands of J. S. Mill. The progress of science has made it easier to formulate its methods and to determine the conditions of valid scientific proof. It is sufficient here to point out that, whereas in formal or deductive logic, reasoning proceeds from a whole to the particulars included under that whole, we seem in inductive logic to rise, in reliance on the uniformity of nature, from observation of particulars to the enunciation of a universal proposition. The nature of the certainty which belongs to such scientific generalisations is one of the subjects which the philosophy of induction has to deal with. The profound interest and value of these investigations, when compared with the rigid framework of symbols with which pure logic presents us, may well lead men to overestimate the former at the expense of the latter. But the two disciplines are essentially distinct; and the exactness and scientific completeness of pure or formal logic will always constitute it a valuable educational instrument.

BIBLIOGRAPHY.—The handiest elementary manuals of logic are those by Jevons and Fowler—Jevons' *Elementary Lessons in Logic*, Fowler's *Deductives and Inductive Logic*—to which may be added Whatly's *Logic*, an older book, and Keynes's *Formal Logic*, which is somewhat more advanced. Among larger treatises in English of comparatively recent date may be mentioned Mill's *Logic*, Hamilton's *Lectures on Logic*, Ueberweg's *Logic* (translated), Bradley's *Principles of Logic*, Bosanquet's *Logic*, Venn's *Empirical Logic*, Jevons' *Principles of Science*, Lotze's *Logic* (translated). The German works of Sigwart and Wundt should also be named. Thomson's *Out-*

lines of the *Laws of Thought*, Baynes's *New Analytic of Logical Forms*, Jevons' *Pure Logic and Other Papers*, Venn's *Symbolic Logic*, and the works of De Morgan and Boole deal with proposed developments of logic on algebraic lines. There is an elaborate history of logic by Fraulit in German; and the works of Trendelenburg in German and of Hamilton and Mansel in English are also valuable in this connection.

Logogram (Gr. *logos*, 'a word,' and *gramma*, 'a letter') is simply a complicated or multiplied form of the Anagram (q.v.), where the puzzlemonger, instead of contenting himself with the formation of a single new word or sentence out of the old by the transposition of the letters, racks his brain to discover all the words that may be extracted from the whole or from any portion of the letters, and throws the whole into a series of verses in which synonymic expressions for these words must be used. The puzzle lies in ascertaining what the concealed words are, and, through them, what is the primary word out of which they have all been extracted. A specimen is given in Henry B. Wheatley's book on *Anagrams* (1862), in which, out of the word 'curtains,' no less than ninety-three smaller ones are framed.

Logos (Gr., 'word,' and also 'reason,' corresponding in Latin to both *oratio* and *ratio*) is a term that has played an important part in philosophical and theological speculation, long ere the 'Word of God' came, through the fourth gospel, to be identified with the second person of the Christian Trinity. The notion of a certain self-manifestation or revelation of the Godhead, standing in some way between the infinite and the finite, has from time immemorial been the property of the whole East. With the Stoics the Logos is the active principle living in and determining the world (see *Stoics*). The apocryphal writers of the Old Testament personify the 'Wisdom' spoken of in Prov. viii. 22, and give it the functions of a Logos. In the Targum *Metura*, 'Word,' is constantly used instead of God or Jehovah. In the Jewish-Alexandrine philosophy (see *PHILO*) the Logos is the Divine Reason, the Power of all Powers, the Spirit of God. The doctrine of the Logos reaches its fullest development in St John's Gospel, where it is the Word of God incarnate. See *JOHN (GOSPEL OF)*, *CHRIST*, *TRINITY*.

Logroño (Lat. *Julia Briga*), the capital of a Spanish province, on the Ebro, 65 miles E. by N. of Burgos. It has manufactures of woollens, machinery, and leather goods. Pop. 13,393.

Logwood, the dark red heart-wood of *Hæmatoxylon campechiannum*, a tree of the natural order Leguminosæ. This tree, which is a native of Mexico and Central America, and has been naturalised in some of the West India Islands, grows to a height of 20 to 50 feet. The tree is generally felled when about ten years old, and the sapwood being worthless is hewed off with the bark. The heart-wood is slightly heavier than water, hard, and close-grained. It has a slight smell resembling that of violets, is astringent, and has a sweetish taste. The source of the colouring properties of logwood is a crystalline substance called hæmatoxylin, $C_{16}H_{14}O_6$, itself colourless when pure, but in an alkaline solution in the presence of oxygen (air) it becomes converted into hæmatein, $C_{16}H_{12}O_6$, which is of a purple-red colour. For dyes use ground or rasped logwood is moistened and made up into heaps or layers in a moderately warm place, where, turned over at intervals, it undergoes fermentation, ammonia being one of the products of the process. The result is that hæmatoxylin is first formed and afterwards hæmatein, crystals of which, of a reddish brown colour and greenish lustre, coat the particles of wood. The hæmatein or colouring matter is easily dissolved by placing the rasped wood, so treated, in hot water. Extracts

of logwood also are made for dyeing purposes. Logwood, although itself dark red, does not produce red colours either alone or with any of the ordinary mordants in use for it. Shades of purple, blue, lavender, drab, and gray are obtained from it with suitable mordants, but none of these are permanent. Its most important application is for dyeing black colours (see *DYEING*). It is also used in the manufacture of writing ink (q.v.). As a medicine logwood is sometimes given in cases of chronic diarrhœa. The introduction of coal-tar colours has not as yet materially diminished the use of logwood as a dyeing substance, as the quantity sent to Great Britain in 1888 (62,306 tons, valued at £366,131) rather exceeded the annual average imports twenty years earlier.

Lohengrin, the hero of an old High German poem, written in the end of the 13th century. He was the son of Parzival, and a knight of the Grail. At King Arthur's command he was taken by a swan through the air to Mainz, where he fought for Elsa, daughter of the Duke of Brabant, overthrew her persecutor, and married the lady. Then he accompanied the emperor to fight against the Hungarians, and subsequently warred against the Saracens. On his return home to Cologne, Elsa, contrary to his prohibition, persisted in asking him about his origin. After being asked a third time he told her, but was at the same time carried away by the swan back to the Grail. Rieckert's edition (1857) of the poem is the best. The poem is a continuation of Wolfram (q.v.) von Eschenbach's *Parzival*. Wagner made it the subject of his great opera, *Lohengrin* (1848).

Loir. See *DORMOUSE*.

Loire (anc. *Liger*), the longest river in France, has its source in the Cévennes, in the department of Ardèche, at an elevation of 4511 feet, flows in a north and north-western direction through the centre of France as far as Orleans, where it bends round to the south-west and continues on to Tours; thence it follows, in general, a western course to its embouchure in the Bay of Biscay. It is tidal to Nantes (q.v.), 35 miles from its mouth. Entire length, 620 miles. It becomes navigable a little above Roanne, 550 miles from the sea. At one time the depth of the water at its mouth was 19½ feet at ebb-tide; now it is only about 6½ feet. This is due to the vast quantity of sedimentary matter the river brings down with it. To the same cause are due the numerous islands that obstruct its lower course and the sandbanks that lie athwart its mouth. The Loire is notorious for the destructive inundations it causes, although the lower part of its course is protected by large dykes or *levées*, 20 feet high. The principal tributaries are the Nièvre and the Maine (which is formed by the Sarthe, its affluent the Loir, and the Mayenne) on the right; and the Allier, Cher, Indre, and Vienne, on the left. The Loire is canalised along considerable stretches of its course, and is connected with the Seine, the Saône, and the harbour of Brest by canals. Its valley is extremely fertile. Area of drainage basin, 44,450 sq. m. See *The Seine and the Loire*, with sixty-one illustrations by Turner (new ed. 1886).

Loire, a department in the south-east of France, formerly part of the province of Lyonnais and the county of Forez, comprises the arrondissements of Montbrison, Roanne, and St Etienne, with St Etienne for its capital. Area, 1838 sq. m.; pop. (1872) 550,611; (1891) 616,227. The basin of the Loire in this department is a rather unfruitful valley, but the mountains yield iron and lead, and the coalfields are the richest in France. Some 17,000 miners are employed in the extraction of nearly 3,000,000 tons of coal annually, 25,000 in the iron industries, 12,000 in the silk, and 5500

in the cotton industries. Woollens, linen, glass, paper, leather, &c. are likewise manufactured. Wine, fruit, fodder, and potatoes are the principal agricultural products. Timber and turpentine are yielded by the pine woods. Mineral springs abound, as at St. Galmier, St. Alban, &c.

Loire, HAUTE, a department of central France, formed out of the former province of Languedoc, the duchy of Auvergne, and the district of Forez, and bounded on the south by Lozère and Ardèche. The Loire crosses it going northwards, the Allier going north-westwards. Area, 1915 sq. m.; pop. (1872) 308,732; (1891) 316,735. The surface forms a plateau, deeply trenched by river-courses; it ranges in elevation from 2000 to 3000 feet, and rises in peaks and domes up to 5755 feet above sea-level (Mount Mézenc). In spite of the ungenerous nature of the soil, agriculture is the chief calling of the inhabitants. But about 120,000 persons find employment at home in making lace from wool, cotton, flax, silk, gold, and silver. Some thousands of the inhabitants leave their houses for a time every year, to work in other parts of France. Coal and building-stone are worked. The arrondissements are Le Puy, Yssingeaux, and Brioude; the capital, Le Puy.

Loire-Inférieure, a maritime department in the west of France, formed out of the southern portion of the old province of Brittany, and comprising the arrondissements of Nantes, Ancenis, Paimbœuf, Châteaubriant, and St. Nazaire, with Nantes for its capital. Area, 2654 sq. m.; pop. (1872) 602,206; (1891) 645,263. It has a coast-line of 78 miles. The Loire, flowing westwards, intersects it and forms a wide estuary; the Vilaine skirts its north-west boundary. In the south of the department lies the lake of Grand-Lieu, 26 sq. m. in extent. The interior is on the whole flat, and the soil fertile, producing cereals, potatoes, beet-root, hemp, and fodder. Bees are kept. There are fine oak and pine forests. Salt marshes are numerous along the shore. The vineyards yield annually about 30 million gallons of wine, and the orchards some 4½ million gallons of cider. Granite, slate, and limestone are quarried. The industrial establishments include ironworks, sugar-refineries, glass-works, factories for tinning fruits and sardines, &c. St. Nazaire has grown into an important seaport, having taken the place formerly occupied by Nantes. Shipbuilding is carried on at Nantes. The coast-fisheries and general export trade are extensive.

Loiret, a department of central France, formed out of the old provinces of Orléanais and Berri, and comprising the arrondissements of Orleans, Montargis, Gien, and Pithiviers, lies on the northern loop of the Loire. Area, 2614 sq. m.; pop. (1872) 355,921; (1891) 377,718. The county is for the most part an elevated, fertile plain, producing corn and wine in abundance, except in the sandy district of Sologne, lying south of Orleans, the chief town. Loiret contains several large forests. Cattle, sheep, and bees are extensively reared. Pottery and porcelain, sugar, vinegar, and soap are the principal industrial products.

Loiret-et-Cher, a department of France, formed out of the old province of Orléanais, comprises the arrondissements of Blois, Vendôme, and Romorantin. The Loire flows through it south-westwards, almost bisecting it. The south-eastern portion belongs to the infertile district of Sologne. The Loire crosses it parallel to the Loire farther to the north-west. Area, 2452 sq. m.; pop. (1872) 268,891; (1891) 280,958. The department is almost a uniform plain. The chief products are corn, fruits, wine, beetroot, and timber. Fish, poultry, and bees abound. Principal town, Blois.

Loja, a decayed town of Spain, on the Genil, 32 miles by rail W. of Granada. It suffered severely from earthquake in 1885. Pop. 18,249.

Lokeren, a town of Belgium, 11 miles by rail N.E. of Ghent, with manufactures of linen, cotton, and woollen goods, lace, chemicals, and tobacco, and large bleach fields. Pop. (1890) 19,667.

Loki, a demigod in the Scandinavian mythology. He did not belong to the race of the Æsir, but to an older dynasty. His appearance is beautiful, and he is possessed of great knowledge and cunning. He often brings the new gods into difficulties, from which, however, he again extricates them. Hence he is to be regarded as the principle of strife and disturbance in the Scandinavian mythology; the 'Spirit of Evil,' as it were, mingling freely with, yet essentially opposed to, the other inhabitants of the Norse heaven, very much like the Satan of the Book of Job. By his artful malice he caused the death of Balder (q.v.). See SCANDINAVIAN MYTHOLOGY.

Lokmán, the reputed author of a certain number of Arabic fables, who gives a title to a *Sura* of the Koran. He is variously said to have been a Nubian slave contemporary with David, and the son of Job's sister or daughter; but others again follow M. Derenbourg (*Fables de Lokmán le Sage*, 1850) in identifying him with Balaam, both names signifying 'devourer.' It is now generally admitted that the fables attributed to his name are late and of Greek origin. See *The Thousand Nights and a Night*, Lady Burton's edition, vi. p. 260.

Lolium. See DARNEL, and RYE-GRASS.

Lollards, a name given to the followers of Wyclif. *Lollardus* was a Latinised form of the old Dutch *lollaerd*, literally 'a singer of psalms,' a term which had been applied to a sect in Brabant akin to the Fratitelli and Beghards; but in English usage it was confounded with the native word *loller*, 'a lazy fellow.' Wyclif's Bible had supplied England with the phraseology and the seminal ideas of a popular theology, and his peripatetic 'poor priests' preached evangelical religion fearlessly throughout the land. Oxford University was a stronghold of the new doctrines, which were most widely spread in the district between the Thames and the Trent. The Lollards' petition to parliament in 1395 contained the famous twelve *Conclusions* against temporal possessions of the church; the ordination of unfit priests; the celibacy of the clergy, and all vows of chastity; exorcism, and blessing of inanimate objects; transubstantiation, the holding of secular offices by priests, prayers for the dead, pilgrimages, image-worship, compulsory auricular confession, war, capital punishment, and such trades as fostered luxury, like those of the goldsmith and the armourer. Many also objected to oaths, denied the necessity of baptism for salvation, and held marriage a mere civil contract. The corruptness and ignorance of the preaching friars made the progress of the new doctrines the easier, and ere long they had obtained enormous influence. There is no doubt that Lollardism prepared the soil for the Peasant revolt of 1381. Its popularity was imperilled by the extravagance of its devotees, and its adherents fell off rapidly under Henry IV., being vigorously persecuted by Archbishop Arundel. The statute, *De Heretico Comburendo*, was passed, and William Sawtre, a Norfolk priest, was burned in 1401, John Budby in 1410. Yet the Lollards remained numerous enough to be formidable at the accession of Henry V. Its most prominent supporter at that period was the martyr Sir John Oldcastle (q.v.), of Cobham, on whom many mocking ballads were written, and whose name was travestied for nearly two centuries after as a fat, dissolute old

knight, his mouth full of Scripture phrases: he was the prototype of Falstaff. Early in 1414 occurred the obscene attempted rising near London, which sent forty Lollards to their doom and proved the death-blow of the cause, but it was not till four years later that Oblecastle himself was captured and put to death. During the early years of Henry VI. the Lollards were sharply persecuted in London and the eastern counties, and some individuals were burned at London and Norwich. But ere long the government ceased to be strong enough for anything beyond self preservation, though it need not be supposed, because the persecution ceased, that the opinions had died out. After the accession of Henry VII. the persecution was renewed, and henceforward the Lollards appear as a secret brotherhood, called the 'known-men' or 'just-fast' men, marrying only among themselves, and instructed by itinerant readers in conventicles. Amersham, Colchester, and Newbury are noted as strongholds. From the time of Henry VIII. Lollardy becomes merged in the rising Protestantism, but it is worth noting that most of the Marian martyrs came from Lollard districts, and that much of their spirit and teaching reappears strongly in Puritanism. Lollardism made its way into Scotland in the 15th century, and became especially strong in the south-western counties, in later times the stronghold of the Covenant. In 1494 thirty persons belonging to the district of Kyle in Ayrshire were tried before James IV. in person, and dismissed with a caution to adhere to the doctrines of the church. *Piers Plowman* reflects closely the religious unrest of its time; but the same is by no means true of Chaucer, whose Parson, when he objects to profane swearing, is denounced as a Lollard.

An interesting account of Lollard principles may be gathered from Reginald Pecock's *Repressor of Over-much Blaming of the Clergy* (ed. by Churchill Babington, Rolls series, 1869), written about 1450. Here the writer assails the three erroneous 'trowings' maintained by Lollardists, or Biblemen, as he styles them. These were (1) that Christian men owe allegiance to nothing but the law of God as stated in Holy Scripture; (2) that any Christian is capable of grasping its plain meaning, if meek and willing to understand; (3) that no one who has so grasped the meaning of Scripture need listen to any clerk's interpretation from Scripture or reason, especially the latter. In the Lollardist assertion that there was no need of human learning to open up Scripture, they but anticipated a delusion not unknown among 19th-century evangelicals. Their claim that none but those enlightened by grace could understand Scripture opened a wider door for self-delusion and error.

See Shirley's *Pasciculus Zaccariarum* (Rolls series, 1858); two papers by James Gardner in *Studies in English History* (1881); and the article WYCLIFFE.

Lolos, a fair complexioned aboriginal people on the frontiers of China and Tibet, mainly in Szechwan and Yun nan.

Lombard, PETER, one of the most famous of the Schoolmen, was born about the beginning of the 12th century, at a village near Novara, in Lombardy. He was educated at Bologna, and came to France with recommendations to Bernard of Clairvaux. His uncommon talents soon procured him a chair of theology in Paris. In 1159 he was appointed Bishop of Paris, but he died in the following year. He was very generally styled *Magister Sententiarum*, or the 'Master of Sentences,' from his work *Sententiarum Libri IV.*, an arranged collection of sentences from Augustine and other Fathers, on points of Christian doctrine, with objections and replies, also collected from other authors of repute. The first book treats of God; the second of the

creature; the third of the incarnation, redemption, and the virtues; the fourth of the seven sacraments and eschatology. A subtle heresy, *Nihilianism*, was detected by some in Peter's teaching, and the theological doctors of Paris in 1300 denounced it in sixteen propositions culled from his writings. Peter Lombard's work was the subject of many commentaries down to the time of the Reformation. His writings were edited by Aleaume (Louvain, 1546).

Lombard Architecture is the style which was invented and used by the Gothic invaders and colonists of the north of Italy, from about the age of Charlemagne till it was superseded by the importation of the Pointed style from France in the beginning of the 13th century. The architecture of the Lombards was derived from the debased Roman style which they found in the country—the general plan of the churches, and the general form of the pillars, arches, &c., being almost identical with those of the Roman Basilicas (q.v.). But in

detail, Roman traditions are almost entirely abandoned, and instead of the debased acanthus leaves and fragments of entablatures the Lombards adopted a freer imitation of natural forms in their foliage, and covered their buildings with representations of the fights and hunting-expeditions

in which they delighted. The north of Italy belonged at the time of Charlemagne to the great German empire, and thus we find nearly the same style of architecture in Lombardy and in Germany as far north as the Baltic (see RHEINISCH ARCHITECTURE). Few early examples of Lombard architecture exist. In the unruly times when the style originated, the buildings were no doubt frequently destroyed by fire; this seems to have led to the desire to erect fireproof structures, and thus the earlier as well as almost all the later examples are vaulted with stone. The earliest example is a small chapel at Frinli, built probably during the 8th century, and it is covered with an intersecting vault. Examples of this date are rare in Italy; but in Switzerland, where the style is almost identical, several interesting specimens of early architecture remain, such as the churches of Romain-Motier, Gramon, Payeme, &c. We there find the peculiar arch ornament so characteristic of Lombardy and the Rhine (Fig. 1), and we can trace the timid steps by which the Goths advanced in the art of vaulting.

The vaulting is the leading feature of Lombard architecture, and from it spring the other distinguish-



Fig. 1.

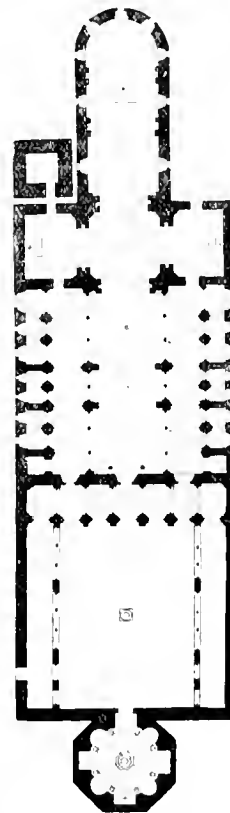

Fig. 2.
Plan of the Cathedral of
Novara.

Scale 1 inch = 100 feet.

ing forms of the style. Thus, the plain, round pillars, with a simple base and capital, which served to support the side-walls and roof of a basilica, are changed for a compound pier, made up of several shafts, each resting on its own base, and each provided with a capital to carry the particular part of the vaulting assigned to it. This change is deserving of particular notice as the first germ of that principle which was afterwards developed in the Gothic (q.v.) styles. Buttresses are also introduced for the first time, although with small projection.

The cathedral of Novara is one of the most striking examples of Lombard architecture. It belongs to the 11th century. The plan (fig. 2) is derived from the old basilican type, having at the west end an open atrium, with arcade around, from which the church is entered by a central door. The interior is divided into central and side aisles, with vaulted roof, and terminated with an apsidal choir. At the end of the atrium opposite the

church is situated the baptistery. The same general arrangement of plan was common in the German churches, where the atrium was sometimes at a later period roofed over and included in the nave, and the baptistery changed into the western apse of the double-apsed churches.

San Michele at Pavia and San Ambrogio at Milan are also good early examples of this style. In both the grouping of the piers into vaulting shafts, wall-arch shafts, &c. is complete, and that beautiful feature of

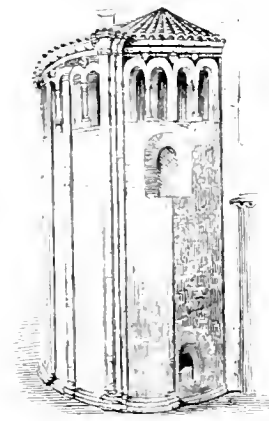

Fig. 3.

the style, the arcade round the apse (fig. 3), is fully developed. The atrium and west front of San Ambrogio form one of the finest groups of Lombard architecture.

Lombards, a people of Germanic descent, who were called by the Latin writers *Longobardi* or, more correctly, *Langobardi*, a name which is differently derived by different authorities. 'Long beard,' *Longe Borde* = 'a long fertile plain beside a river,' *borde* being used in that signification in the Lower Elbe district, and *longa paxa* or *harte* = 'a long battle-axe,' have all been suggested as original forms of the name. The people so designated first appear in history as settled about the Lower Elbe, in Hanover and western Prussia, at the dawn of the Christian era. In the two centuries that followed they came more than once into conflict with the Romans; and then till the end of the 5th century nothing more is known about them. When next mentioned (*circa* 455) the *Longobardi* were settled in Moravia, and were tributary to the Herulians. The oppression of these masters stung them into revolt: they subdued the Herulians, and after them the Gepidae, and established themselves as the ruling race in Pannonia. Under Alboin, their king, they invaded Italy in 568, and at the end of three years had possessed themselves of the greater part of Northern and Central Italy, Pavia being the last city to submit. They subsequently extended their power as far south as Spoleto and Benevento, both of which duchies were held by Lombard dukes. His second successor, Authari, assumed the Roman

title of Flavius, and under the influence of his queen, Theodelinda, a Frankish princess, the nation began to change its Arian faith for the Catholic. The *Longobardi*, though never a numerous race, were distinguished above most of their Germanic brethren for their fierce love of war and their rude manners. But in Italy they soon fell under the influence of the existing civilisation: they adopted the Latin language, began to build churches and found monasteries, and gradually became assimilated with the Italians. King Rothari in 643, and his successors, embodied the legal customs of the Lombards in a code, written, however, in Latin—*Leyes Longobardorum*. Liutprand, king from 712 to 744, made an unsuccessful attempt to subdue all Italy. His strongest opponent was the pope, who summoned the Franks to his assistance. Charlemagne in 774 overthrew the Lombard dynasty, and had himself crowned king of the Franks and the Lombards; and thenceforward the Lombards were entirely merged in the Italians. The only traces extant of the Longobard language are a few names. Their earliest historian whose works survive, Paul the Deacon, wrote in Latin. See **LOMBARDY**.

The 'Lombards' in England.—In the 13th century Italian merchants from Lucca (even as early as the 9th century), Florence, and Piacenza, and at a later date from Venice and Genoa also, visited England for purposes of trade. They came originally to collect the taxes and dues payable to the pope, which they transmitted in large part in the shape of wool. They also traded on their own account, and in course of time, settling in the country, were granted special privileges, such as the right to farm the customs and to conduct the transactions on exchange. The merchants of Florence, for instance, had branches at Boston, Lynn, and Northampton, as well as at London, and regularly bought the wool of some 200 monasteries in England and Scotland. On occasion they lent large sums on loan, and gradually took up the business of banking, as it was understood in those days: Edward III. owed the Florentine house of Bardi the sum of 900,000 gold ducats, and another house of the same city, that of Peruzzi, 600,000 ducats. The Jews even took advantage of the favourable position of these Italians: many of them braved Edward I.'s edict of expulsion (1290), and stayed behind under the character of Lombard merchants, the name by which these Italians were generally known to the English. In London the Lombards dwelt principally in the street now called Lombard Street, still the chief centre of the banking interest. They eventually incurred as much odium as the Jews, not only because they exacted interest for their loans, but also because the commercial privileges accorded to them were believed to injuriously affect the native English merchants.

Lombardy, that part of Upper Italy which lies between the Alps and the Po, having the territory of Venice on the east, and Piedmont on the west. Its geographical characteristics are discussed under **ITALY**. Its history begins with the conquest by the Romans in 222, who called it *Gallia Cisalpina*. After the break up of the Roman empire it was successively in the hands of Odoacer, the Ostrogoths, the Byzantine emperors, and the Lombards (q.v.). Charlemagne incorporated it in his empire, but from 843 it was ruled by a separate line of kings, though before the kingdom ended (961) it had broken up into a number of independent duchies and civic republics. The Lombard cities, like those of Flanders at a later epoch, grew wealthy by industry and trade, and nurtured a vigorous love of freedom and independence. They resisted sturdily and successfully the attempts of the emperors Frederick I. and II. (q.v.) to curtail their

liberties, forming themselves into strong leagues, which were powerful enough to rout the emperors in pitched battles. But, freed from threatening danger, they began to quarrel amongst themselves, and the country was for many years more or less distracted by internal dissensions. After the death (1447) of the last duke of Milan, whose ancestor, Count Azzo, had acquired the sovereignty over nearly all Lombardy in 1337, the country was made an object of contention between the king of France and the emperor. The last named having got the better in the contest, Lombardy passed through Charles V. to Spain, which held possession of it till 1713, when the duchies of Milan and Mantua came into the hands of Austria. Napoleon made it part of the Cisalpine republic, the Transpadane republic, and the kingdom of Italy successively. But in 1815 it was restored to Austria, and associated with the newly-acquired Venetian territory. In 1859 Lombardy was given up to Italy, and divided into the provinces of Bergamo, Brescia, Como, Cremona, Mantua, Milan, Pavia, and Sondrio. See Hodgkins, *Italy and her Invaders* (vols. v. and vi.); W. K. Williams, *The Communes of Lombardy* (1891).

Lombok. See SUNDA ISLANDS.

Lombroso. See CRIMINOLOGY.

Lomond, Loch, the 'queen of Scottish lakes,' in Dumbarton and Stirling shires. Lies 23 feet above sea-level, and is 22 miles long, $\frac{3}{4}$ mile to 5 miles wide, 6 to 630 feet deep, and 27 sq. m. in area. It is studded with thirty wooded islands; receives the Endrick and six other principal streams; sends off the Leven 7 miles southward to the Clyde; contains trout, pike, and perch; is sometimes frozen over as far northward as Luss; and is enlivened by hills and, towards its head, Highland mountains, the highest of which, Ben Lomond (q.v.), attains 3192 feet. In 1263 Norsemen launched their galleys on Loch Lomond, having drawn them across the narrow isthmus of Tarbet; on Incheilloch stood of old a nunnery; and a cave is associated with both Bruce and Rob Roy.

Louza, the capital of a government in Poland, 80 miles N.E. of Warsaw, was formerly one of the most important cities of the country, but is now of secondary rank only. Pop. 15,000.

London is situated on the north or left bank of the Thames, about 60 miles from the sea, in 51° 30' 48" N. lat. and 5° 48" W. long. It may be reckoned the capital of the British empire, but the Houses of Parliament and the offices of government are in the adjoining city of Westminster. The Thames at London Bridge is about 900 feet wide, being much wider both above and below. This fact probably accounts for the original foundation of the city, which, according to many authorities, took place in 43 A.D., when Aulus Plautius was the Roman governor of Britain. The name is Celtic, and would appear to signify a fort on a lake or lagoon, the Thames being here a tidal estuary which covered all the low-lying land on which Rotherhithe, Newington, Southwark, and Lambeth are now situated. It seems likely that the easiest ford across the river was at Westminster, where it was widest (more than 1200 feet), and that by the building of London Bridge at the narrowest place the old Watling Street from Dover toward Chester was diverted. The old line led from Edgware through Tottil Fields to Westminster, where Stone Gate still marks the place of crossing. The newer road turned eastward at what we call the Marble Arch, and, passing diagonally from Newgate through the city, crossed by the bridge, and was carried on towards Dover on embankments among the shallows, the sites of which are still marked by such local names as Stone Street and Newington Causeway. The course of Watling Street in the

city was again diverted, probably in the 13th century, to make way for the extension of St Paul's Cathedral, and now no longer leads in the direction of Newgate.

During the greater part of the Roman occupation of Britain London consisted of two forts, one at either end of the bridge; and Ptolemy, the geographer, puts London in Cantium, where, and not on the left bank, it is very possible the largest of these forts may have stood. The unwall'd suburbs seem to have been populous and wealthy from an early period; and, when abandoned by Suetonius, they were burned by Boadicea in 61 A.D. They were still undefended in 286 and the subsequent years, when the rebel emperors, Carausius and Allectus, held both sides of the channel, making Clansentum (Bitterne, near Southampton) their headquarters in Britain. Asclepiodotus, the general of Constantius, defeated Allectus in the neighbourhood of London, and under one of the Constantines the place began to be looked upon with favour and to be extensively fortified. The wall which for so many centuries was destined to defend the boundaries of the city was built between 350 and 369, and enclosed a space which has been computed at 380 acres. In this Roman wall there was a gate due north of the bridge in what is now Canonile Street, and another at the spot at which the Watling Street, crossing the Fleet or Holborn, took its course towards Tyburn. The new city was defended on the east by the Lea and its extensive marshes, and on the west by the Fleet, whose waters were tidal as far up as what we call King's Cross. Traversing the middle of the city was the narrow stream of the Wallbrook, with the harbour of Dowgate at its confluence with the Thames, and from the remains which have been discovered it is probable that the chief Roman fort, before the building of the outer wall, was on the east or left bank of the Wallbrook, and extended far enough eastward to cover the approaches to the bridge. Some bastions of peculiar strength where the wall reached the Thames on the site of the Tower gave rise to the medieval tradition that the Tower of London was built by Julius Caesar. From 369 till 412 London was reckoned the capital of Britain, and enjoyed the title of *Augusta*. After the Roman departure London disappears from history until 457, when the Britons, fleeing before the victorious Hengest, took refuge behind the Roman wall. How far it availed them for defence we know not. London does not again emerge from complete obscurity for about a century and a half, but in 604 we find it named as the 'Metropolis' - i.e. the ecclesiastical capital - of the East Saxons. Mellitus was appointed first bishop, but the Saxons soon expelled him, and Christianity did not make much way with them until Ethelbert, king of Kent, the over-lord of the East Saxon king, took the matter in hand. A little later we hear for the first time of a tribe of Middle Saxons, but London was evidently a place of but small importance, apart from its bridge, as the Saxons preferred to fight without walls, and as no doubt the Roman defences had become greatly dilapidated. At length during the Danish wars they became completely ruinous, and London was abandoned and lay desolate during the long period of thirty years, the lifetime of a whole generation.

To King Alfred we must look as the real founder of modern London. He saw the possibilities of the place as a bulwark against the Danes, and, repairing the wall and gates, made the place again habitable. There is a tradition that he specially rebuilt and strengthened a work on the site of the Tower. During the long period of disaster which followed his reign, the kingdom of some of his

successors consisted of little else but London, which the Danes were never able to take, even though they made a canal round Southwark, and half rowed, half dragged their ships to Westminster. Undoubtedly the settlement made in London, whether by Alfred or by one of his immediate successors, formed the germ of the subsequent municipal government. Athelstan is often pointed to as the king who chiefly restored London, and, as we have nothing else, tradition must be received with some respect. The Roman lines of road and the gates were abandoned. New gates at Aldersgate, Newgate, and Bishopsgate were constructed, and posterns seem to have been opened at Landgate (A.S. *Ludgat*, 'a postern'), Cripplegate (A.S. *Crepulgat*, 'a covered way'), and possibly at what was afterwards Moorgate. There were two great market-places, one near the western gate, in which the folk-mote was held, and where stood the church of St Paul; and the other in East Cheap, of which the only modern remains are Leadenhall Market and the fish-market at Billingsgate. The West Cheap was bordered by the highway still called Cheapside, which led from Cornhill, the northern extremity of the East Cheap, by a bridge over the Wallbrook to the Westgate, now Newgate. There were many empty spaces within the circuit of the walls, and, if we may judge by the comparative size of the local divisions, the first settlers chose the shores of the Thames and the lines of the two great roads for their habitations. It is very probable that ecclesiastically the city was divided into three great parishes; one, of which St Paul's was the church, to the westward; a second, of which St Mary Aldermary was the church, in the centre; and a third, possibly dedicated to All Saints, or All Hallows, in the east.

The municipal government before the Norman conquest was not very complicated in form, and may be compared to that of a county elsewhere in England. The lords of manors in the city were represented by aldermen of wards, and the ward division is the oldest with which we are acquainted. Every magnate had his ward; and the government was carried on by the bishop who was alderman of the ward about St Paul's, and the portreeve who had the Portsoken outside the city to the east. It is not easy to unravel the knot presented to us by the names we meet with in old records of city officials in and before the 11th century. A guild, composed chiefly or wholly of aldermen, was perhaps, under the name of *Knigheten Guild*, the governing body; but this is by no means certain, nor is the tradition that King Edgar was their first founder. Some such body existed; its members transmitted their rights to their sons, and they may or may not have become the governing guild of the city. The king's reeve, or port-reeve—*port* probably denotes a market—answered to the sheriff or shire-reeve of a county; and the aldermen of wards had many and extensive powers on their respective estates, answering to those exercised in a county by the lords of manors. The reeve united in his own person many offices afterwards separated. He was chamberlain or treasurer; he was 'vicecomes,' and accounted to the king's exchequer for the farm of the city; he was coroner; he was escheator; he often bore office as a royal minister, like Ansgar, 'the staller,' who fought and was wounded at Hastings. William recognised the great position and ancient rights of London in a special charter by which the privileges enjoyed by the citizens under Edward the Confessor were confirmed to them; but the most important grant from the crown was that of Henry I., who, in 1101, in recognition no doubt of the assistance London had given him in his successful attempt to seize the crown, allowed them,

among other things, (1) the right to elect their own chief-magistrate, and (2) the farm of Middlesex at an annual rent, with power to appoint a sheriff of that county. These extraordinary grants, with that of leave to hunt in the neighbourhood of London, are so unlike what we should expect from a Norman king, that some have been tempted to suppose that they were all renewals of privileges enjoyed under the Saxon kings, and there is much plausibility in this view, but their recognition led eventually to the establishment of the mayor. The sheriffs of London and sheriff of Middlesex were no longer 'high' sheriffs; they were the nominees and deputies of the whole body of the citizens. As at Winchester, and some other places, the mayor does not seem to have received any royal acknowledgment during his first years of office; but the date 1189 is generally assigned as that of the first year of Henry, the son of Ailwin, an alderman of old family. There seems to be a question whether this Ailwin is to be identified with a citizen of that name who in 1125, with all his brethren of the Knighten Guild, became canons of the priory of Holy Trinity at the newly-opened Algate (now corruptly called Aldgate), and conferred, with the king's leave, the title of an alderman (of the ward of Portsoken) on their prior, Norman. Be this as it may, the necessities of the kingdom, and the difficulties consequent on the payment of the ransom of Richard I., must be taken as causes for the recognition of the new chief-magistrate; and down to our own day, when (Local Government Act, 1888) this ancient custom was abolished, the citizens elected annually, on Midsummer Day, two sheriffs for the city, one of whom was sheriff also of Middlesex on alternate days. They are now elected for the city only. They enter on their office on Michaelmas Day, and the citizens then proceed to choose the Lord Mayor. Legally any citizen is eligible for the mayoralty, but for many generations the senior alderman who has not passed the chair is chosen.

This may be the most convenient place in which to name the chief municipal officers. The mayor, who has been called 'Lord Mayor' from time immemorial, is held to rank as an earl, but within the city boundaries next to the sovereign. In commissions of Oyer and Terminer his name precedes even that of the Lord Chancellor, and since the reign of Edward III. he has sat as a judge. At first the Lord Mayor was a representative of the city in the House of Commons, and he still takes a seat at the opening of parliament on the ministerial bench. He attends at the Law Courts to be sworn in on the 9th November, and holds office for a year. He is in the city in the position of the Lord-lieutenant of a county, and a commission of lieutenancy is issued to him and the magistrates he may nominate. The Chamberlain is the city treasurer. The office was separated from that of mayor when the mayoralty was temporarily superseded in the reign of Edward I. He is the official guardian of the orphans of citizens, and has special charge of apprentices. He is annually re-elected during good conduct. The Recorder is the legal adviser of the Court of Aldermen. Geoffrey Hartpole, elected in 1304, was the first Recorder. The Common Serjeant stands in the same position toward the Common Council, who have also their Common Clerk, now called town clerk. The first Common Serjeant was Thomas Juvenal, elected in 1290. The Court of Aldermen now consists of twenty-six members, of whom the senior sits for the ward of Bridge without, or the borough of Southwark. The others are elected by the city wards.

The Common Council was first elected in 1200, when twenty-five citizens were chosen by the

wards to take council with the aldermen. There are now 206 common councillors.

The Common Hall consists only of members of the Livery Companies, and has obtained or usurped many of the rights of the whole body of citizens. An act passed in 1725 regulates admission to the franchise of the city through the livery, but seems to have been founded on a misapprehension, as the Act of 1475 which it was supposed to confirm does not seem to have ever existed. Admission to the citizenship could be obtained by application to the Hustings Court, as well as by joining a company, but the latter course, being the easiest, became usual, and so was supposed necessary.

The hustings, a meeting of the whole body of the citizens, was called in other cities Portmannimote, and was an assembly under cover, as distinguished from the folkmote, held at first in the open space between St Paul's and West Cheap, and afterwards in Smithfield.

The growth of this municipality was slow. At first the rights of the aldermen possessed of hereditary jurisdiction interfered with its progress; but by degrees all the wards were able to elect their aldermen. The interference of the crown also greatly retarded the prosperity of the city. Nevertheless, commerce increased, and the settlement of such foreign merchants as those of the so-called Steelyard, and of the Lombard and other Italian bankers, raised London by the time of Edward III. to a wealthy and prosperous condition. In reading a detailed history it is observed that weak sovereigns caused a depression of trade, while under a strong government confidence was restored and capital was safe. Henry III. was constantly at feud with the citizens, whom he greatly oppressed, leaving to his successor the task of dealing with the disorder he had created. Edward I., to use the language of contemporary chroniclers, 'took the city into his own hands,' and his ministers, Sandwich and Breton, governing like mayors, with the help of the aldermen and the common council, brought everything into order. In 1290 they expelled the Jews. After twelve years the mayoralty was restored. Under Edward II., again, there was disorder and discontent in the city, the great body of the citizens adhering to the party of the queen. Under Edward III. London prospered, new privileges were granted to the mayor, and the French wars were extremely popular. In the end, however, a reaction ensued, and under the weak government of Richard II. things did not improve. The usurpation, as many deemed it, of Henry IV., could hardly have succeeded had it not been for the support of the city; and Henry V., whose French victories inflated trade, was most popular with the citizens. Henry VI. was unable to grapple with the inevitable period of depression which naturally followed; and his queen, Margaret of Anjou, failing to gain the confidence of London, whose importance to the Lancastrian cause she did not know, contrived to divert the weight of the city influence into the opposite scale. The reign of Edward IV., with his strong commercial instinct, by reviving and creating outlets for foreign trade, restored the prosperity of the city. Under the Tudors there were great fluctuations. Although the settled government of Henry VII. tended on the whole to the satisfaction of the city, his continual exactions and the heavy fines he imposed for trivial offences, alienated its loyalty. The accession of Henry VIII. was an occasion of rejoicing. The tenets of the Reformation were warmly welcomed in London, where the priests, monks, and friars had become a heavy burden; and at first the high handed proceedings

of the king in the suppression of the religious houses and the confiscation of their endowments was a popular measure. The further suppression of guilds under his successor led to a considerable change in the feeling of the citizens, many of whom, but for the religious persecution under Queen Mary, would have been very willing to return to the old faith.

The guilds had for centuries been an integral part of the social life of the citizens. The municipal guild, or what we know of it, has already been mentioned. At an early period after the Conquest we hear of 'trade guilds,' that is, of combinations of men of one calling for religious and other purposes. The many attempts made of late to distinguish between trade guilds and religious guilds have ended in failure, for all guilds were religious, and most religious guilds were trade guilds as well. As time went on the governing body occasionally found it convenient to consult a trade guild on the regulation of their particular business. This was especially the case under such mayors as Walter Harvey (1271-72), who, indeed, made an endeavour to enrol every citizen under the banner of a guild of his trade, and to formulate rules for each. Though he failed, his ideas took root; and in a few years many of the guilds obtained royal charters forming them into companies, able to hold lands, and in some cases, as that of the goldsmiths and that of the fishmongers, to regulate the conduct of their respective trades. The old guilds were thus generally merged in the companies whose governing bodies acted as trustees of the funds of the guilds. There was probably a good deal of confusion between the guild property and the companies property, but for the most part that of the guild could be distinguished, because it was applied to religious purposes. The act which confiscated these funds made, of course, a profound impression on the city. Some companies were wholly ruined, having perhaps no funds but those which might be applied to a 'guildable use;' and others, more prosperous, found it expedient, and even necessary, to sell their company estates in order to buy the guild estate which they had administered. The companies which recovered from this heavy blow prospered for the most part eventually, and those now extant deal with large charitable funds and hold large estates, to the great benefit of their tenants and their pensioners.

Under Queen Elizabeth the work of the Reformation was continued and completed. The history of the church in London was greatly complicated with that of the municipality. We have seen that the bishop was an alderman; but at a very early period, a period in fact so early that no record of its date survives, the ecclesiastical and lay administrations drifted apart, and the church had less and less concern in the affairs not strictly religious. There are historical reasons for believing that St Paul's was at first a parish church, but before the end of the 12th century, perhaps as a consequence of the great fire of 1136, the parochial arrangements of the whole city were readjusted, new parishes were formed and their boundaries marked, and a great number of new churches were built. The dean and the lordly canons of St Paul's no longer cared to have the common people worshipping in their church, and built St Peter-le-Queene, at the corner of Cheap, with St Gregory and St Faith closely adjoining St Paul's, the one at the east end, the other at the west. The canons of St Martin's built St Vedast's, and the friars of Newgate Street St Ewen's; and private individuals or wealthy aldermen increased the number of churches as long as they could obtain parishes to attach to them.

When land failed for this purpose, they founded chantries, some in St Paul's, some in other monastic and parochial churches. No doubt the act *Quia Emptores*, which in 1290 practically forbade the subdivision of manors, had its influence in restricting the multiplication of churches, but the number of city parishes (114) was out of all proportion to the population, great comparatively as that must have been; and, since churches were built rather as chapels where mass might be celebrated than for any other purpose, the later Puritan and Protestant idea, that they should be places where a large number of people could listen to sermons, had no influence on their dimensions. Although there was no abbey in the city, if we except St Mary's in East Smithfield, a Cistercian house founded by Edward III., and sometimes called Eastminster, which never flourished, the number of priories, colleges, and hospitals was immense. The Whitefriars had a large house on the south side of Fleet Street in the western suburb. The Blackfriars occupied the south-western corner of the city, and had leave to divert the course of the wall between Ludgate and the Thames. The Greyfriars were within Newgate, on the site now occupied by Christ's Hospital. Close to them was St Martin-le-Grand, a very ancient foundation for canons, which, in the later years of monasticism, having fallen into decay, was attached to Westminster Abbey. Close to the Franciscans on the north, but without the wall, was the Austin Canons' house in Smithfield. Elsing Spital was within Cripplegate. The Austin Friars had great buildings near Moorgate, and St Helen's Priory, for nuns, occupied the eastern side of Bishopsgate Street. The canons of the Holy Trinity held Aldgate, and south of their priory was that of the Crutched Friars. The suburbs teemed equally with religious houses, and there were several minor foundations within the city. The number of mass priests attending altars in St Paul's alone was reckoned at over one hundred; and the great pestilence of 1348 added largely to the chantries and chapels. In the 15th century this state of things became an intolerable burden, and contemporary literature is full of complaints. Unfortunately, in abolishing monasticism the beautiful churches of the monks and friars were not respected, and although one or two were named as worthy of preservation as preaching-houses, all perished except a portion of Austin Friars and the nuns' aisle of St Helen's. The Austin Friars' church, wholly disguised under a mistaken idea of 'restoration,' still remains as a Dutch church. Even St Paul's was mutilated: the campanile and the cloisters known as Pardon Churchyard were ruined; and after the destruction of the lofty spire, 520 feet high, by fire in 1561, the whole church fell into a very dilapidated condition.

The influence of the church told also upon London in another way. The addition of suburbs to the city as 'wards without' was prevented by the ring of ecclesiastical estates which gradually closed round it. On the east was Stepney, a manor belonging to the bishop. The mayor and corporation obtained a lease of the manor of Finsbury from a prebendary of St Paul's in 1315, and held it till 1867, when it was taken up by the Ecclesiastical Commission. To the westward there were several prebendal manors, and outside Temple Bar was the great parish and manor of St Margaret, Westminster, which belonged to the abbey. Southwark was annexed to the city in 1327, and was made a 'ward without' in 1550. But in addition to Portpool (now Gray's Inn), St Pancras, Ruggmere (now St Giles's), and Bloomsbury, the Moor (or Mora), at Cripplegate, Isling-

ton, Hoxton, and Eald Street (now Old Street), St Luke's, all of which were manors belonging to canons of St Paul's, the Knights of St John had Clerkenwell; the canons of St Bartholomew, Canonbury; the abbey of Barking had Tyburn, or the eastern half of the parish of St Marylebone; the Knights of St John had the western half, or Lylloston; the abbey of Westminster owned Paddington and Westbourne; and the abbey of Abingdon, Kensington. Finally, the abbey of Westminster held Chelsea for a time. It will be seen that every extension of the city jurisdiction was effected with great difficulty, and the effects of the division of the monastic estates by the Tudor dynasty did not greatly benefit the city, which in fact only obtained St Bartholomew's Hospital and the Grey Friars' from Henry VIII., and Bridewell from Edward VI.

The accession of Queen Elizabeth gave a considerable impetus to London trade. Her reformation of the coinage was only one item of a settled policy; and the Merchant Adventurers, chartered by her father, now stepped into the place previously occupied by the Germans of the Steelyard, which was abolished at the instance of the famous Gresham. The last charter of Queen Elizabeth was granted to the East India Company. The silk manufacture, driven out of Flanders by the cruelties of the Spaniards, was naturalised in England; and even the short-sighted policy of the first Stuart could not repress the rapidly-growing enterprise of the Londoners, whom the discovery of America and of a sea-passage to India stimulated to greater and greater exertions.

While the wealth and population of London thus increased during the 16th and part of the 17th century, the city itself became less and less fit for habitation. Its unhealthiness was partly caused by the deficiency of the water-supply, partly by overcrowding. The plague scarcely ever left its narrow streets and filthy alleys. The sanitary arrangements of the time of Edward I. were scarcely suited to the needs of the time of James and Charles. But, known only to a few Londoners, Sir Hugh Myddelton, by bringing clean water to the city in abundant quantity, bestowed upon it the greatest possible boon. This was in 1620; but some forty or fifty years elapsed before the New River was made generally available. In the meantime the citizens were overwhelmed with one great misfortune after another. James I. had reverted as far as he could to the mistaken policy of such kings as Henry III. and Richard II.; but it was reserved for Charles I., after a long series of high-handed proceedings, to seize the money of the city goldsmiths deposited in the Tower. His downfall was certain when the city turned against him; but, except for a very brief period, the Commonwealth found little favour in London, and Cromwell imposed one humiliation after another upon the citizens. Charles II. was warmly welcomed, and it was mainly owing to the co-operation of the wealthy merchants with Monk that his return was possible. But Charles followed in the footsteps of his father. Extortion and oppression were the instruments of his policy, and in 1672 he closed the Exchequer, and ruined nearly all the London bankers at a blow. He never afterwards was able to win the confidence of the citizens, on whom two other disasters of even greater vehemence had already come, the Great Plague of 1665 and the Great Fire of 1666.

There had been many previous visitations of the plague, and to that of 1625, long known as the Great Plague, 35,000 deaths were attributed. But the epidemic of 1665 threw all others into the shade. It commenced at St Giles's, in the suburbs, and the official statements enumerated the deaths

during the year at 97,306. As the population was reckoned at about 500,000, it will be seen that nearly a fifth perished.

There had also been many great fires, but that of 1666 exceeded them all. It commenced on the 2d September, at 1 o'clock A.M., in Pudding Lane, and raged for five days. It was estimated that 396 acres of houses were destroyed, fifteen city wards were consumed utterly, and eight others damaged, comprising 400 streets, 13,200 private houses, 88 churches and St Paul's Cathedral, and 4 city gates. The loss in mere money was estimated at about 4 million. It took London many years to recover from this terrible misfortune. Sir Christopher Wren built a new St Paul's, and also gave us St Stephen's, Wallbrook (until 1888, when it was in great part ruined by the parochial authorities), the chief monument of his powers after the cathedral, the spire of St Mary-le-Bow in Cheapside, and many other beautiful buildings, including the Monument, set up near where the fire began. This is a Tuscan Doric fluted column 202 feet high. St Paul's has a dome 404 feet high and 145 feet in external diameter; the length of the building east and west is 500 feet. Street, commenting on the superiority of St Paul's to St Peter's as an architectural composition, says: 'The great magnitude of the latter may strike the vulgar eye with admiration in the contrast; but the rudest taste must appreciate the surpassing merit of the former in the form and arrangement of the cupola and the noble peristyle' (see WREN). It contains many memorials, the best of which are Wellington's, in the Consistorial Court, on the south side of the nave, by Stevens; Lord Melbourne's, by Marochetti; and a recumbent figure of General Gordon, by Boehm. In the crypt are buried Lord Nelson (1805), Reynolds (1792), Turner (1851), Wellington (1852), Landseer (1873), and Wren himself (1723). The Exchange (q.v.) of Sir Thomas Gresham was burned, rebuilt, and then burned again, and finally rebuilt in 1844 by Sir William Tite. The Guildhall, partly of the 13th century, partly of the 15th, which had been the scene of so many historical events, was damaged in 1666, but not destroyed, and was handsomely restored first by Jarman, an eminent contemporary of Wren, and more recently by Sir Horace Jones. Among the churches spared by the fire is St Bartholomew's, in part, a fine Norman structure; St Giles's, Cripplegate, built 1545, in which John Milton (born in Bread Street, 1608) was buried, 1674; St Helen's, Bishopsgate, full of fine monuments; St Katharine Cree, said to have been designed by Inigo Jones, 1631; and St Andrew Undershaft, in which is Stow's monument.

During the rest of the reign of Charles II. and the whole of that of his successor, the city and the court were more or less at variance; and in 1683 Charles took London, to use the old phrase, into his own hands. The Lord Mayor was deposed, the charter was seized, and both aldermen, and also a so-called Lord Mayor, in reality a warden, were appointed by the king. At first James II. carried on his brother's policy towards the city. At the news of the landing of the Prince of Orange the charter was sent back, but the concession came too late, and the judicial murder of Alderman Cornish was too fresh in the minds of the citizens. In December 1688 they formally petitioned William to assume the crown, and in a few hours found ample funds for his use. Subsequent events were largely influenced by the city, and it has often been observed that the opposition of London, in old times fatal to a king or his family, has of late equally affected the fortunes of a ministry. King George III. was galled by the supremacy of the citizens as Henry III. had been before him; but

he made no way against them. The last events that need be noticed here are the establishment of the Bank of England in 1694; the removal of the old wall and its gates in 1760; the clearing of the houses from London Bridge about the same time, and its complete rebuilding in 1831, when it was only one of a large number of bridges. A great number have been built since then; the latest addition, a bridge below the Tower, is an engineering work of great importance, which will add greatly to the picturesque aspect of the east of London. See BRIDGE, Vol. II. p. 416.

The population of the city has dwindled year by year, and especially since the multiplication of railways. Few tradesmen now live in their place of business, and the difference between the number of people who actually reside within the ancient boundaries and of those who only come in to business is immense. In 1881 there were 6493 inhabited houses and a population of 50,526; but 25,143 houses were used during the day, when the population rose to 261,061. The rateable value of property was, in 1887, no less than £3,767,000. Meanwhile the suburbs have spread in all directions, and the houses of Londoners are found in Berkshire, Buckinghamshire, Hertfordshire, and Sussex, as well as in Kent, Surrey, Essex, and Middlesex.

The city has its own police force, in six divisions, with seven stations and two courts—one at the Mansion House, the official residence of the Lord Mayor, and one at the Guildhall. Several railway stations have been made within the precincts of the city, as the Temple, Blackfriars, the Mansion House, the Monument, and Mincing Lane on the Metropolitan Railway, with Cannon Street Terminus, which stands exactly on the site usually claimed for the Roman pretorium. The diocese of London has varied very frequently in extent, having at one time comprised Middlesex, Essex, and Hertfordshire, besides the city. It now consists of the city with Middlesex, and that part of the new county of London which was formerly reckoned in Middlesex. The bishop resides in Westminster, and at an ancient manor house of the see at Fulham. There is a dean of St Paul's who resides close to his church, on the site of the old brewhouse of the chapter. He is assisted by four residentiary or stagiarj canons, and by a precentor, a chancellor, and two archdeacons, and there are thirty canons of the old foundation, now usually called prebendaries, and a college, incorporated by Richard II., of minor canons.

London formerly returned as many as six members to parliament, of whom two were supposed to be on duty at a time. From about 1357 the number was usually four. Under the Reform Act of 1885 it was reduced to two.

Like other ancient towns the city of London had its own customs, some of which still have the force of law. Thus, by the custom of London, every shop is deemed an 'open market' for the goods usually sold there. There were also special rules as to the prosecution of certain classes of offenders, &c. The London custom which governed the succession to personal property was taken away in 1856. There is a customary right of foreign Attachment (q.v.).

THE COUNTY OF LONDON. Under the Local Government Act of 1888 a new county was defined, to consist of the suburban parishes of Middlesex, Surrey, and Kent. These parishes, or a great part of them, had previously been described in certain acts as 'the Metropolitan Area,' a term quite inappropriate. By the Act of 1888 a county council was provided for this district, and the jurisdictions formerly existing of the city of London, and the authorities of the three counties were abolished. Before describing the new county we may point

out that under this act the county of Middlesex (q.v.) was removed from the sheriffship of the citizens, and divided, one part forming a new county of Middlesex, and the other, united with parts of Surrey and Kent, forming the new county of London. The work of the County Council has been multifarious and far-reaching, and has evoked a corresponding amount of criticism. By the London Government Act of 1899 the administrative county of London, with the exception of the City, which had heretofore been under the authority of more than a hundred and twenty local authorities (vestries, district boards,

burial boards, &c.), was reorganised into twenty-eight municipal boroughs, each under a municipal council. These boroughs are: Battersea, Bermondsey, Bethnal Green, Camberwell, Chelsea, Deptford, Finsbury, Fulham, Greenwich, Hackney, Hammersmith, Hampstead, Holborn, Islington, Kensington, Lambeth, Lewisham, Paddington, Poplar, St Marylebone, St Pancras, Shoreditch, Southwark, Stepney, Stoke Newington, Wandsworth, Westminster, Woolwich. The councils have all the power and duties of the old vestries and district boards and some of those of the London County Council. The suburbs form a ring round the city, and the

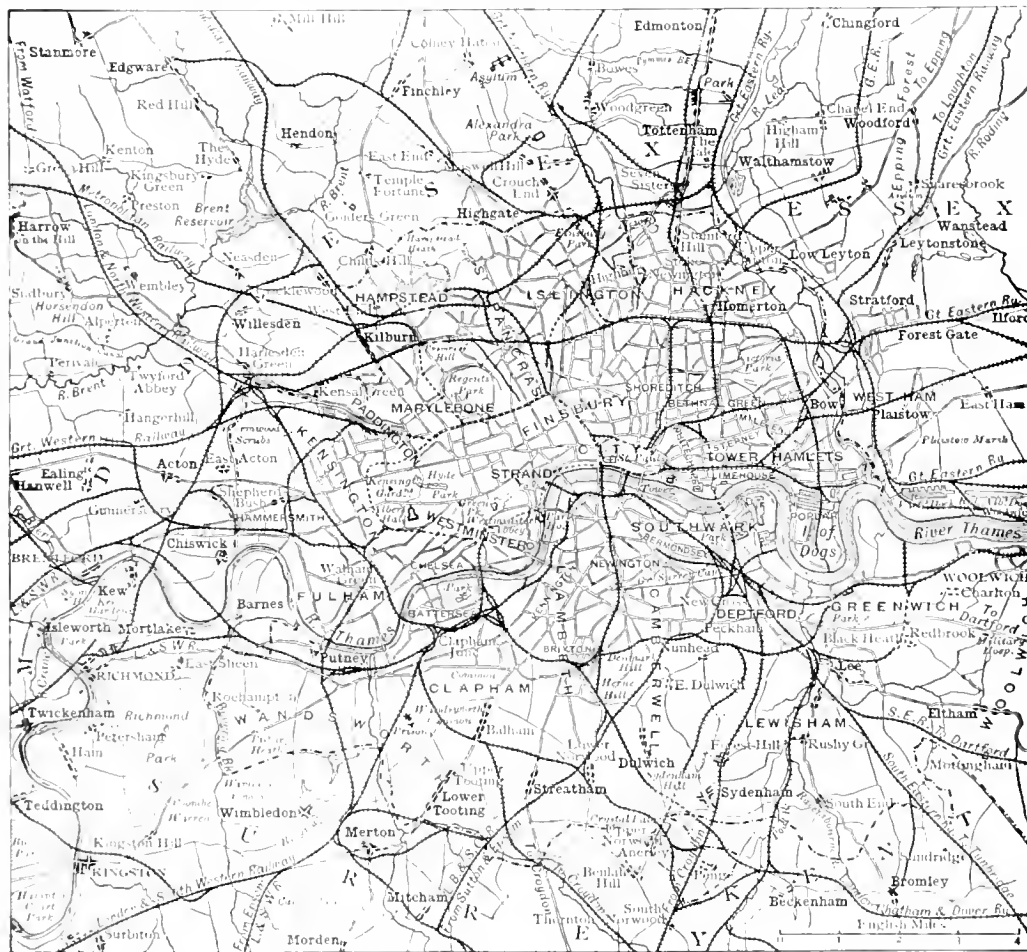

efforts of the medieval rulers were directed—first, to restricting as much as possible their growth; and secondly, to bringing them, when they were settled, under the control of the city. In this policy the Londoners were unsuccessful. The suburbs grew in spite of city and parliament; and by 1222 a continuous street united Westminster with London; another stretched beyond the Tower to Stepney; and a third, flowing out of Bishopsgate, reached northward to Islington. In the same 13th century the city made its final attempt to keep the suburbs under control. A great 'ward without' was formed westward, extending to the Temple and Holborn Bars; and, on the north, part of Moorfields was made a 'ward without' in the jurisdiction of the alderman of Bishopsgate. But, except for the formal addition of Southwark in Surrey, made

in 1327, confirmed and defined in 1550, no further extension of the city liberties took place. The estates of the church stopped the way. London was surrounded by manors, of which ecclesiastical dignitaries and monastic bodies were the lords. Foremost among these were the canons of St Paul's and the Bishop of London. Stepney, an immense parish to the eastward, belonged to the bishop, all that is, except such parts of the precinct of the Tower as were taken out of it. On the west the Abbot of Westminster had the parish of St Margaret, which at first came up to the Fleet, at what we know as Ludgate Circus, and was with difficulty pressed back beyond Temple Bar. The abbot continued to hold the churches in the new ward, and the dean and chapter still present to St Bride's, Fleet Street. On the north, the canons

of St Paul's held Cantler's, now Kentish Town, Eald Street, Hoxton, Islington, and St Pancras, while Mora and Wenlocksborn were parts of the parish of St Giles, Cripplegate. Other canons, monks, and friars, and the Knights of St John and of the Temple had holdings in Smithfield and Canonbury, at Clerkenwell and in St John's Wood, and in the Temple. All these church estates were in hands which bitterly resented any interference on the part of the city; and when the monastic orders were abolished, their estates were for the most part granted to individuals at least as tenacious of their independence. The canons of St Paul's had already for the most part ceased, owing to the prevalence of a corrupt system of leasing, to own except in name the manors of which they had been the lords. In the more distant parishes similar influences were at work, and except in Westminster, where the abbot and his successor, the dean, held the reins of local government, the parishes of the so-called Metropolitan Area were governed by elected vestries and other such institutions, and the lands were divided and parcelled out in freeholds, some large and a few small, among owners who had little general control or influence.

The precinct of the Tower, eastward of the city wall, was formed partly by aggressions on the

Lady Jane (Grey) Dudley lived, is in good preservation, but is now, for some unknown reason, called the Queen's House. The Beauchamp and Devereux towers seem to have held the most illustrious prisoners; they, with the Bell Tower, in which Fisher, Bishop of Rochester (1534), and Mary, Countess of Lennox (1565), were confined, form the western side of the inner ward, being united by a curtain wall, on which the prisoners walked. Unfortunately, the inscriptions from many different chambers have been brought together in the principal room of the Beauchamp Tower, by which their historical significance has been in some cases wholly lost. Here we see, among others, memorials of the incarceration of the six sons of John Dudley, Duke of Northumberland (beheaded 1553). Of them, John, the eldest, was released and died; Ambrose, the second, became Earl of Warwick, and lived till 1599; Guildford, the third, was beheaded on the same day as his wife, 12th February 1554; Robert, the fourth, is best known as Queen Elizabeth's Earl of Leicester, and died in 1588; and Henry, the youngest, was killed in the French wars in 1558. Other illustrious prisoners were Edward, Earl of Warwick, called the last of the Plantagenets, beheaded 1499, and his sister Margaret, Countess of Salisbury, beheaded 1541; Edward Seymour, Duke of Somerset, beheaded 1552; Sir Thomas More, 1535; Thomas Cromwell, Earl of Essex, 1540; Queen Catharine Howard, 1541; Henry Howard, Earl of Surrey, 1547; Henry Grey, Duke of Suffolk, 1554; Sir Walter Raleigh, beheaded at Westminster in 1618; Thomas Wentworth, Earl of Strafford, 1641; William Laud, Archbishop of Canterbury, 1645; James Scott, Duke of Monmouth and Buccleuch, 1685; James Rueliffe, Earl of Derwentwater, 1716; and the Scots lords implicated in the risings of 1715 and 1745—Kennure, 1716; Kilmarnock and Babmerino, 1746; and Lovat, 1747. Many of these prisoners were buried in St Peter's Church, which having been burned in 1512 was rebuilt in time to receive the bodies of Queen Anne Boleyn and other victims of the Tudor times. It was 'restored' some years ago in a very thorough manner, every vestige, except some



The Tower of London from the River.

citizens, partly by acquisitions from the lord of Stepney, and partly by reclamations from the Thames. Two bastions of the old wall, generally called Roman, and certainly dating back to the reign of Alfred (see above, p. 696), were removed, and the White and Wakefield towers were built on them. They were fenced round by a palisade at first, but by the end of the 12th century the precincts comprised 26 acres, about 12 being covered with buildings. Gundulf, a monk of Bee, designed the White Tower, begun in 1078. The works went on steadily, the chapel of St John in the White Tower being supplemented by the parish or precinct church of St Peter 'ad Vincula' on the Green in the reign of Henry II. The keep is approximately in the centre, and is surrounded by walls and towers forming the inner and outer wards. The towers of the inner ward were those chiefly used for prisoners' lodgings, but a complete royal palace was in the south eastern corner. Of this palace, from which Queen Anne Boleyn went to her death on the adjoining green, scarcely a vestige remains. The lieutenant's lodgings, where, or in the chief warder's house next door,

monuments, of the period which witnessed these sad scenes being carefully obliterated. The crown jewels were long kept in the Brick Tower, at the north-eastern corner, but in 1867 were removed to a chamber in the Wakefield Tower. This chamber, in which they are now exhibited, has shared the fate of the chapel, every vestige of its occupation by Henry VI, probably at the very time of his death, having been carefully 'restored' away. The great collection of armour, founded by Henry VIII, in his palace at Greenwich, is on the upper floor of the White Tower. Two or three pieces date from before the time of the Tudors. The ticket-office, by which the visitor enters the fortress, is on the site of a menagerie which dates back to the time of Henry I, whence the saying 'to see the lions,' meaning to visit the Tower. The principal feature of the outer ward is St Thomas's Tower, or the Traitor's Gate, facing the Bloody or Garden Tower, the entrance of the inner ward. The view of the Tower from the westward is much interfered with by the new bridge, but, except for some ugly barracks and the demolition of the palace, has still very much the aspect it bore in the 17th century.

The new bridge just mentioned starts from the boundary between the precincts of the Tower and that of St Katharine's Hospital, an institution founded by Matilda, the queen of Stephen, and refounded in 1273 by Eleanor, queen of Henry III. It still subsists, having been spared at the Reformation, but was removed in 1827 to the Regent's Park, and St Katharine's Dock made on the old site. A little farther east, still on the Thames bank, we come to one of the numerous divisions, known as the Tower Hamlets, into which the original parish of Stepney has been parcelled. This used to be Ratchiff and Wapping, but has long been known as St George's in the East. Next to it is Limehouse, a name whose original form, Limehurst, sufficiently denotes the old character of the region. Next to Limehouse is Poplar, which includes the Isle of Dogs, a kind of delta formed by the river Lea, which derives its name from its docks. Farther inland are Bethnal Green, a vast district, chiefly covered with factories and with the houses of the lower class of artisans and labourers. Mile End, Old and New Towns, whose names show their situation on the great eastern road made through Aldgate (see above) in the 12th century, which led to an arched bridge, locally known as the Bow, where there had previously been only the dangerous Stratford over the Lea. These parishes, with Whitechapel north of the Tower, form a complete ring round Stepney, where an ancient church, dedicated to St Dunstan, still stands among surroundings very different from those which marked the district when the bishops of London had a palace here, with wide parks, and the noble hunting grounds of Hackney and Hornsey on the hills beyond; when Edward I. held a parliament in 1299 at the house, near the church, of the mayor, Henry le Waleys; when the good Dean Colet had a country house here, where he was visited by More and Erasmus; and when Bishop Ridley, the martyr, surrendered the manor to Lord Wentworth, the same whose loss of Calais is said to have been the proximate cause of the death of Queen Mary I. Since Wentworth's death the estate has been divided among many owners, and there are few traces of antiquity anywhere. The Bethnal Green Museum of the Science and Art Department is in a style not likely to improve the architectural taste of the neighbourhood, but has housed and exhibited various fine collections of pictures and works of art. Much of Hackney, which adjoins Stepney on the north, has been kept open; an old park of the bishops being now laid out as Finsbury Park, and the commons and fields eastward to the Lea having been rescued from the builder. South of this district, which stands high, are Haggerston and Hoxton, densely populated parishes, comprising the ancient Shore-ditch, and reaching to the city wall. Westward are the two divisions of Finsbury, St Luke's and Clerkenwell. In St Luke's was the 'Artillery Ground,' or place of exercise for volunteer bowmen, from which the modern Artillery Company took its rise. In Clerkenwell, but not strictly speaking of it, is the Carthusian monastery, now a kind of refuge for decayed gentlemen, known as the Charterhouse. Here was formerly a school, in which John Leech was educated as well as Thackeray, who describes the place under the name of the Slaughterhouse. In the Liberty of Saffron Hill was a palace of the bishops of Ely, and their chapel, a beautiful building sold to the Roman Catholics in 1874, still exists in Ely Place. Clerkenwell, the site of the house of the Hospitalers, has still its St John's Gate, with memories of Dr Johnson. Northward and westward, we come to a group of old prebendal manors. Islington has a very ancient history

extending back to the time of the Conquest; Stoke Newington with a curious old church and a new one; St Andrew's, Holborn, in which Lord Beaconsfield was baptised, and in the cemetery of which, in Shoe Lane, Chatterton was buried in 1770; Portpool, the original name of the ground now covered by Gray's Inn, whose great ornament was Lord Bacon; and Rugmere, now known as St Giles's and Bloomsbury. The last named district, in which the British Museum is situated, was brought by the good Lady Rachel Wriothesley to her second husband, William, Lord Russell (beheaded in Lincoln's Inn Fields in 1683), and still belongs to her descendants, the dukes of Bedford. The celebrities of Bloomsbury have been too numerous to mention; but we cannot forget Richard Baxter, who lived in Southampton, now Bloomsbury Square; Charles Dickens, who lived long in Gower Street and in Tavistock Square; and Charles Lamb, who lived in Little Queen Street.

In St George the Martyr, a small parish taken out of Holborn, is Queen Square, called after Queen Anne. Macaulay lived at 50 Great Ormond Street while he was a boy. St Giles's, long a rookery of wretched tenements, has been greatly cleansed and improved of late, but the too famous Seven Dials continue to deserve an evil reputation. Some of the streets and squares of the district were places of repute two centuries ago. Nell Gwynn lived in Wardour Street, the Duke of Monmouth in Soho Square, Dryden in Long Acre and in Gerard Street. The small parish of St Paul, Covent Garden, boasts of a church designed by Inigo Jones, of the greatest vegetable and flower market in London, and of innumerable literary associations. In Bow Street was Wilks's Coffee-house, where Pepys met Dryden; Turner, the landscape-painter, was born in Maiden Lane; Charles Lamb lived in Russell Court; and Pope, Sheridan, Butler, and Prior are among the names we meet with in the history of the locality.

We now reach the Strand. Beginning at its eastern end, next to Temple Bar, we have the colossal buildings of the New Law Courts (1874-82), of which George E. Street was the original designer; but so thwarted by meddling authorities, that only the best features, such as the noble hall (238 feet long) and the tower, can be considered his. North of the courts is Lincoln's Inn Fields, the largest square in London. Here is situated the College of Surgeons, with its museum, and the museum of Sir John Soane. Close to the Law Courts is the church of St Clement Danes, by Wren, in which a brass tablet marks the seat habitually occupied by Dr Johnson. On the south side are Arundel and Norfolk streets on the old site of Arundel House. Essex Street commemorates the residence of Queen Elizabeth's unfortunate favourite in the Outer Temple. A brook ran through Milford Lane, and in Strand Lane is a bath of Roman origin. Next, to the westward, we come to the charming little church of St Mary, by Gibbs, and to Somerset House, now full of government offices, built by Chambers (1786), after a design of Inigo Jones. Here Anne, queen of James I., resided. The name is derived from the Duke of Somerset (beheaded 1552), who built a house here. The streets on the north side compete with Fleet Street as the headquarters of periodical literature. Before we reach Waterloo Bridge (see *BRIDGE*) we are in the precinct of the Savoy, continuous with a manor granted by Henry III. to Peter of Savoy, uncle of Queen Eleanor. Here John of Gaunt resided till the palace was burned by the rioters of 1381. Chaucer, who married a sister of the duke's third wife, was much here. It afterwards became a hospital, of which the chapel,

dedicated to St John the Baptist, only remains. In it Gavin Douglas, Bishop of Dunkeld (died 1522), lies buried. Fuller officiated here during the reign of Charles I. The hospital was suppressed in 1703, and the chapel made 'royal' in 1773.

The Thames Embankment (1864-70) borders the Strand from the city round a great bend of the Thames at Charing Cross to Westminster. When we pass the city boundary near the Temple, we are abreast of the building of the London School Board, by Mr Norman Shaw, R.A., next to which, with a short interval, is the river-front of Somerset House, by Chambers, one of the best elevations in London. Gardens beautifully laid out conduct us past the Savoy, the Adelphi Terrace, an Egyptian obelisk bearing the names of Thothmes III. (18th dynasty) and Rameses II. (19th dynasty), and the old gateway which marks the site of Buckingham or York House, where Bacon was born in 1561. Charing Cross station occupies the site of Hungerford Market. The cross in the court toward the Strand is believed to be a copy of the Eleanor Cross erected by Edward I. The statue of Charles I. stands on its exact site. Northumberland Avenue was made in 1874 over the site of the last of the great riverside palaces with which the Strand was formerly lined on the south. Trafalgar Square is on the site of the old King's Mews. Its chief ornament is the church of St Martin 'in the Fields,' by Gibbs (1726). The National Gallery is a poor building (by Wilkins, 1838). The National Portrait Gallery behind it was opened in 1895.

The monumental Corinthian column to Nelson is very conspicuous, with four lions by Landseer at its base. Behind it is a statue of General Gordon by Thornycroft. There are other statues, all poor. For Whitehall, see WESTMINSTER. A statue of George III., by Wyatt, is in Cockspur Street, which leads us past the Haymarket and its great opera-house to Waterloo Place, where is Bell's Guards' Memorial, a very poor figure of Victory in bronze, the Duke of York's (Tuscan red granite) column with statue by Westmacott; and monuments, mostly very bad, to Franklin, Lord Clyde, Lord Lawrence, &c. The clubs in Pall Mall are in many cases justly admired, and, except those most recently built, are in good proportion, especially the Reform, designed by Barry, and the Carlton, by Smirke, and give a stateliness to the street, sadly wanting as a rule in London. At the War Office is part of Schomberg House, occupied by Gainsborough, the painter. When we reach St James's Palace (in Westminster) we turn up St James's Street, noting at the corner a beautiful insurance-office by Mr Norman Shaw. Opposite, on the west side, are several well-proportioned clubs, but some new buildings, covered with ornament, intended apparently to conceal weak designs, go far to spoil the view. Near the top of the ascent are White's, Boodle's, Brooke's, and Arthur's clubs, all celebrated in the social annals of the century, and on the site of Crockford's, the Devonshire. In Bennett and Arlington streets we are reminded of one of the members of the Cabal. Lord Salisbury's obtrusively ugly house looks on the Green Park. In Arlington Street resided another prime-minister, Walpole, and afterwards his son, Horace Walpole.

Piccadilly begins a little to the eastward of Waterloo Place (see above) and its continuation Regent Street, and is called from a kind of teagarden, Piccadillo Hall, which stood where the Criterion is now. The formation of Regent Street, which was to lead from Carlton House (where the York column now stands) to the Regent's Park, which was beautifully laid out on the old Marylebone common, must be ascribed to Nash, to whom must also be assigned the street fronts, often very beautiful, although executed only in

stucco. In the Regent's Park are situated the Zoological and Botanic Gardens. In Piccadilly there are still some fine palaces, as Devonshire House, Northampton House, the residence of Lord Rothschild, and Apsley House, but the finest of all, Burlington House, has been altered and added to in a wretched style, and the architect-earl's design can hardly be made out. Here are lodged the Royal Academy, the Royal, the Antiquarian, the Linnean, and several other learned societies. The gardens are covered by the exhibition rooms of the academy, and by the offices and theatre of the university of London, in a very debased style, overloaded with ornament. The only church in Piccadilly is St James's, the parish having been taken out of Westminster in 1684. It was built by Wren, at the expense of Jermyn, Earl of St Albans, who is generally believed to have been the second husband of Queen Henrietta Maria, and who is commemorated in the adjoining Jermyn Street. The exterior is plain, but the interior is the model and criterion of what a Protestant church should be.

Northward and westward is the great parish of St George, Hanover Square, separated from Westminster in 1724, which comprises Mayfair, Grosvenor Square, and Belgrave, extending from Oxford Street on the north to the Thames on the south. It contains many churches, more or less dependent on St George's, but though some of them are very costly, not one calls for separate mention. The mother-church is heavy in design, except the portico. It is by John James. The parish nearly all belongs to the Duke of Westminster, whose ancestor, Sir Richard Grosvenor, married in 1676, Mary Davies, the heiress of two city families, by which these then open fields had been acquired, not without litigation, in the reign of Queen Elizabeth. The whole estate consists of an almost circular portion around Grosvenor Square, extending along Oxford Street from Davies Street to Park Lane, and bounded on the east by the water-course of the Tyburn; and a southern portion, bounded on the west by the Westbourne, which divides it from Chelsea, and on the east by Grosvenor Place, Vauxhall Bridge Road, and some irregular streets down to St George's Square, which is on a site named in a map of 1723, as 'Mr Weston's garden.' The new churches on this magnificent estate are typical of the other buildings. There is not one which can be named as of good, or even tolerable, design. Belgrave Square and Eaton Place, and the adjacent region are all in stucco. Grosvenor Place is in a French style, very debased. Dorchester House, not on, but bordering the estate in Park Lane, is handsome, having been designed by its owner with the assistance of Vulliamy. In Stanhope Street is Chesterfield House, much pulled about, but still fine, and worthy of its designer, Ware. Grosvenor House has few architectural features, but the picture-gallery in Park Lane is in a fair classical style, and the screen in Grosvenor Street has been admired.

Of St Pancras, large as the parish is, there is very little to be told. It contained, apparently, several of the manors of the canons of St Paul's, and a curious little church, much injured by modern, and indeed recent, restorations, shows Norman features. It is close to the St Pancras terminus of the Midland Railway, and is well worth a visit for the sake of the graveyard adjoining, which, though much curtailed by the railway, still comprises some interesting monuments, those, for example, of the Greys, lords of Portpool, now Gray's Inn; of Walker, the lexicographer; and of Sir John Soane. Many refugees during French and Italian troubles were buried here. In the parish is Kentish Town, the old prebendal manor of 'Cantler's' or Cantelupe's, called after an

ancient canon, and now the estate of Lord Camden. Somers Town used to belong to the family of Somers Coorks. The new parish church of St. Pancras is a very conspicuous object in the Euston Road. It was built in what was thought to be a Grecian style in 1822, by the Inwoods. Another remarkable building is the Midland terminus with a hotel, by Sir G. G. Scott, one of the largest buildings of the kind.

Tyburn was anciently the name of the parish which we know as St. Marylebone. It presents some curious and interesting features. Unlike most parishes it seems never to have been contained in a single manor, but was divided before the dawn of history into two at least, if not three. This division, or inclusion, may have been caused by its remote and lonely situation. A brook ran through it, 'the bourne from which no traveller returns,' its source hidden among the wooded hills of Middlesex; and the little church of St. John was in 1400 pulled down because it had been so often broken into and robbed. A new church was built higher up the brook, where there were a few houses, and the place is still known from its new dedication, *St. Mary-le-Bourne*. The brook was known as the Tyburn, the earlier form of which points to a double stream, and the original church probably stood on a kind of island, a site now covered by the bookseller's shop of Mr. Bumpus. The eastern part of the parish formed the manor of Tyburn, and belonged to the abbey of Barking. It was leased out to various people, and in the 15th century was held by Thomas Hobson. Henry VIII. held the manor, and Queen Elizabeth granted it on lease to Forest, who in the succeeding reign bought it. His descendants sold it to John Holles, Duke of Newcastle, for £17,500, and it has ever since descended in his family, Lady Ossington being the present owner. The western part of the parish was the manor of Lilleston, now commemorated in Lisson Grove, and descended much like the eastern half, through lease-holders, who held from the Knights of St. John (whence St. John's Wood), down to Sir William Portman, whose descendants now own the greater part of it. The western boundary is the Edgware Road. The place of execution for the city of London and the county of Middlesex was at first by the burnside, where in 1330 Roger Mortimer, Earl of March, was hanged. As the suburbs increased and crept towards St. Marylebone, the gallows were removed farther west. In 1512 they stood in the adjoining manor of Lilleston, close to the modern Marble Arch, and eventually they were set up for each execution at the foot of Edgware Road. A house, recently rebuilt, the New Inn, is pointed out as the place where the stout beams of the triangular gibbet were kept. At one or other of the places thus indicated, the Holy Maid of Kent (1534), many priests in the reign of Elizabeth, Felton, the assassin of Buckingham (1628), Jack Sheppard (1724), Jonathan Wild (1725), Lord Ferrers (1760), Mrs. Brownrigg (1767), and the Rev. W. Dodd (1777) were hanged, with an innumerable company of less notable criminals. The last execution here was that of John Austen (1783). It may be worth while here to note that Tyburnia is not in Tyburn, nor yet in Lilleston, but in Paddington. The number of eminent inhabitants and natives of St. Marylebone is very great. Hogarth represented the church, now a parish chapel, in his *Rake's Progress*. Gibbs, the architect, Gibbon, the historian, Hoyle, who wrote on games, and Charles Wesley, the hymn-writer, may be mentioned as having lived or died in the parish. Besides these, we must not omit the Harley family and their famous collection of MSS. now in the British Museum; Oxford Street is called after Edward Harley, second Earl

of Oxford and Mortimer, who married the Holles heiress.

North of St. Marylebone is Hampstead (q.v.), with its splendid open heath, some parts of which are as much as 450 feet above the sea. Paddington lies wholly westward of the Edgware Road. It was early divided into two manors, Paddington and Westbourne, the latter named after a little stream the original source of the Serpentine. Both belonged to Westminster Abbey, but the eastern manor having been appropriated to the bishopric of Westminster, with most of the other estates of that short-lived see, went to the see of London, while Westbourne is still the property of the abbey. There is little of interest in either division. The Great Western Railway and its terminus cover a large part of both, obliterating Westbourne Green where Mrs. Siddons once lived. A small part of Kensington Gardens is in Westbourne, and in the adjoining manor is a cemetery which belongs to St. George's, Hanover Square, and contains the grave of Lawrence Sterne.

Westward of Kensington (q.v.) is Hammersmith, a populous suburb, taken out of Fulham, which reaches down to the Thames, and forms the western extremity of the county. A very interesting church, St. Paul's, built here in 1631 by Sir Nicholas Crispe, has recently been pulled down, and a new church of great size, but otherwise unworthy of the site, has been built in its place. It is designed in a mock-Gothic style. In a better style are some nunneries and other institutions of the Roman Catholics.

Fulham boasts of an ancient church and of the so-called 'palace' of the bishops of London. The manor which is, or was, contemporaneous with the parish, has been the property of the see from time immemorial, and remains the one residential estate of the bishop. The house, which has sometimes been described as the oldest inhabited house in England, surrounds a courtyard. A chapel, consecrated by Bishop (afterward Archbishop) Tait in 1867, is adjoining the house in the grounds. The exterior is unnecessarily plain, but the interior is handsome. The house contains a hall built by Bishop Fletcher (1595), and the arms of Bishop Fitzjames (died 1522) are in the courtyard and in the garden, which lies very low but contains many fine trees and shrubs. The church of Fulham is very plain but contains a few fine monuments. In the churchyard are the graves of eight bishops. Close to them is a tomb which bears the name of Theodore Hook (died 1841), who had a house, now removed, in the village. Of late years the numerous pleasure-grounds and open spaces of Fulham have been covered with second-class houses, and we have but scanty remains of Parson's Green, North End, and other classical localities. Chelsea (q.v.) adjoins Fulham.

Crossing the Thames, we reach that part of Surrey which has been included in the new county. Battersea is chiefly remarkable now for the beautiful park, opened in 1852, close to which was the residence of Henry St. John, Viscount Bolingbroke (died 1751). Westward of Battersea is Wandsworth, south of it is Clapham, and beyond that Penge, in which is the Crystal Palace, usually called from the neighbouring Sydenham. All these are covered with streets, interspersed here and there with villas. Kewington, the site of a manor-house of the princes of Wales, Brixton a little farther south, and Norwood, on the summit of the southern line of hills which enclose what is called the London Basin, come next, and the manor of Lambeth faces Westminster. The archbishops at first rented the house from the see of Rochester, on account, no doubt, of its convenient situation. They finally acquired it by exchange in 1196. The

domestic parts of the house are modern, but the chapel was built about 1250, the 'Lollards' Tower,' 1440, the gateway, 1490, and the hall, now the library, in 1663. There are many beautiful MSS. and rare printed books in the library. The associations of Lambeth with the greatest men in England are too numerous to be detailed here, but we may remember that Bishop Parker (died 1575) is buried in the chapel, and that this was the scene of More's refusal to accept the king's supremacy. St Mary's parish church is close to the gate and contains monuments of archbishops Bancroft, Tenison, and Secker. Two modern buildings are very conspicuous at Lambeth—Doulton's terracotta factory, south of the palace, and St Thomas's Hospital, which unfortunately faces the Houses of Parliament, having been removed to this site in 1871 to make way for London Bridge station. The architecture is unusually ugly, even in London.

From this point eastward to Southwark (see above) the low peninsula, formerly submerged at every high tide, is occupied with mean streets and lanes, and with great warehouses, stores, and wharves; the only point of interest being that on which Shakespeare's Bank-side Theatre the Globe stood. The approaches to Waterloo Bridge probably cover the site. Eastward of Southwark are Bermondsey, where a fine and famous abbey flourished before the Reformation, of which nothing remains, and Rotherhithe, at an abrupt bend of the Thames. Both districts are densely covered with factories and labourers' dwellings. Farther inland and to the southward are Newington, Walworth, the immense parish of Camberwell, with Dulwich College and picture-gallery, and Peckham. All are densely populated, but present few objects of antiquarian or picturesque interest.

Eastward of Camberwell we enter those parishes which are taken from Kent. They comprise Lewisham, a good part of which is still open; Deptford, Greenwich, and Woolwich, which includes some fields on the north side of the Thames. There are many interesting sites in this district. At Deptford was Sayes Court, which John Evelyn lent to Czar Peter; Eltham Palace, with its ancient hall, built by Edward IV.; the Woolwich Academy, for Royal Engineers and Artillery; and Greenwich (q.v.), with its magnificent hospital and its park, and the observatory from which we and most civilised nations reckon longitude.

The commerce of the vast area thus briefly described is in great part carried on in the City; but the best retail shops are in the Strand, Regent Street, and Bond Street. The statistics of the cattle-markets are published at intervals, and show a constantly increasing demand and supply. The tonnage of the port now exceeds 6 millions, and the total trade exceeds 226 millions sterling. The rateable value of the whole county, including the city, amounts to over 30 millions sterling. The annual consumption of food includes 2 million quarters of wheat, 400,000 oxen, 1,500,000 sheep, 8 million head of poultry, 400 million pounds of fish, 500 million oysters, 180 million quarts of beer, 8 million quarts of spirits, and 30 million quarts of wine, besides coal to the amount of 6 million tons.

The following tables show some London statistics:

POP. IN VARIOUS AREAS IN 1891.

	Acres.	Pop.
City of London	608	37,694
County of London (with City)	75,412	222,118
London School Board District	"	"
Registrar-general's Tables of Mortality	75,331	4,211,056
Metropolitan and City Police Districts, 441,539		5,633,352

London within the Registrar general's district: (1800) 958,863; (1811) 1,918,417; (1861) 2,083,989; (1871) 3,254,260; (1881) 3,816,483; (1891) 4,211,056. Rateable value within Metropolis Management

Act: (1859) £12,045,476; (1869) £16,257,643; (1879) £23,960,109; (1889) £31,592,387. Miles of streets: (1801) 470; (1821) 610; (1841) 905; (1861) 1290; (1881) 1740. Houses: (1801) 130,000; (1881) 520,000.

	Imports of Foreign and Colonial Merchandise.	Produce of United Kingdom exported.	Foreign and Colonial Produce exported.
1855	£132,699,036	£50,517,252	£34,845,773
1886	128,008,767	46,125,495	34,455,430
1887	129,430,751	46,023,152	35,339,715
1888	138,183,465	50,211,258	37,572,768
1895	145,937,445	44,613,355	35,977,526

The customs revenue was: (1865) £10,942,913; (1885) £10,584,956; (1895) £9,479,788 (as against £3,030,405 at Liverpool). The total foreign trade of London is over a fourth of that of the United Kingdom, and is to that of Liverpool as £225,000,000 is to £187,000,000. For some industries London is more important than any other town in the kingdom. In 1891 there were 83,448 dressmakers, milliners, &c., in London, 52,346 tailors, 35,069 printers, and 31,867 cabinetmakers.

The death rate of London in 1855 was 24.3 per 1000; in 1881.90 it was 21.4; it is now little over 17. In London in 1891, 65 per cent. of the population were London born, and there were 59,390 persons of Scottish birth, and 66,465 of Irish birth. Of 95,653 foreigners, 26,920 were German, 12,034 Russian, 14,708 Polish, 10,366 French, 5138 Italian, 4903 American (U.S.), 4289 Dutch, 3041 Austrian, 2244 Spanish, 2044 Belgian, 1432 Swedish, 1011 Norwegian, 827 Danish.

See Stow's *Survey* (1599); Maitland's *History* (1756); Newcourt's *Repertorium* (2 vols. 1708); Cunningham's *Handbook* (1849; new ed. by Wheatley, 3 vols. 1891); Sharpe's *London and the Kingdom* (1894); Paul's *Vanishing London* (1896); Thorne's *Environ* (2 vols. 1877); Walford's *Greater London* (2 vols. 1885); Baedeker's *Handbook* (1889); Hutton's *Literary Landmarks* (4th ed. 1888); Cassell's *Old and New London* (6 vols. 1887); Loftie's *London* (1892); the larger (1892) and smaller (1893) works by W. Hoesant; and many local histories. See also the following articles in this work:

Banking.	Greenwich	Obelisk.
Bridge.	Grill.	Parliament.
British Museum.	Hampstead.	Police.
Charterhouse.	Hospitals.	Royal Academy.
Chelsea.	Immigration.	Royal Society.
Christ's Hospital.	Kennington.	Sydenham.
Club.	Kew.	Temple Bar.
Covent Garden.	King's College.	Thames.
Deptford.	Mint.	Theatre.
Dock.	National Gallery.	Water-supply.
Fire.	Newgate.	Westminster.
Fleet Prison.	Newspapers.	Woolwich.

London. UNIVERSITY OF. This title was originally assumed by the non-sectarian institution afterwards known as University College, London, the fine building of which, situated in Gower Street, W.C., was opened in the autumn of 1828. The functions of the college were confined to teaching; but in 1834 its promoters applied to the government of the day for power to grant degrees. Meanwhile, King's College (q.v.) had been founded by adherents of the Church of England; and it seemed not improbable that other colleges of similar character would be (as indeed they were) established. If, therefore, the degree-giving power had been accorded to University College, there would have been no excuse for refusing it to King's and other colleges. Hence, to avoid the multiplication of little universities, the government resolved to institute a body which should examine, but not teach, leaving the colleges to teach, but not examine—at least, not for degrees. A charter constituting such a body (the University of London) was issued by the crown on November 28, 1836, and this charter was up to that of 1863 (valid till 1900) followed by four others, as well as by two or three supplemental charters, varying the constitution or extending the powers of the university.

For the first twenty-two years of its existence the university comprised (a) the governing body, or senate, made up of a Chancellor, a Vice-chancellor, and thirty-six 'Fellows'; and (b) the affiliated colleges and medical schools. At first University and King's were the only affiliated colleges; but in twenty years the number of the arts colleges had grown to about fifty, and of the medical schools to nearly twice as many; and of each class only a small minority were in London. Almost a revolution in the university was effected by the charter of 1858 (of which the charter, dated 1863, and in force till 1900, was an amended form). Previously candidates for degrees in arts, although they might matriculate from anywhere, had been required to produce a certificate of two years' study at an affiliated college; but now this requirement was abolished, and candidates might acquire their knowledge when, where, and as they chose. The requirements from medical candidates, however, were not relaxed, and indeed were subsequently made more stringent. The same charter also introduced the graduate body, under the title of 'convocation,' into the constitution; and all masters of arts, all doctors, and all bachelors of a certain standing, upon payment of a trifling fee, became members of convocation. This body became the parliamentary constituency. Again, this charter instituted the Science faculty; and it took away from the fellows the power (which some of them had exercised) of acting as examiners. The chief organic changes between 1858 and 1899 were the institution of degrees in music and the opening of the university to women. The latter change was a gradual process; at first women were admitted to a series of special examinations under a supplemental charter of 1867; but under a later supplemental charter (1878) all the examinations and degrees, and all the exhibitions, scholarships, prizes, and medals were thrown open to them upon precisely the same conditions as to men. The field covered by the operations of the university may be described as imperial rather than local. Its charter declares it to have been founded for the benefit of all classes and denominations of Her Majesty's faithful subjects, without any distinction whatsoever, both in the United Kingdom and elsewhere. In conformity with the character thus professed, certain examinations were to be held at numerous provincial centres in Great Britain and at a few colonial centres. But the university itself originated none of these; they were instituted only upon the application of recognised authorities at the several centres.

This very feature, however, and the detachment of the university from the once affiliated colleges, were the immediate cause of a lively agitation for a 'Teaching University' for London, which sprang up in 1884, and led to negotiations which in 1900 issued in the reconstitution of the university. The senate in 1887 made some concessions, but rejected the claim of the colleges to be represented at its own board. University and King's Colleges, in combination, thereupon petitioned the Privy-council for a university charter of their own; while the Royal Colleges of Physicians and Surgeons, also in combination, petitioned for the power of granting degrees in medicine only. To investigate the merits of the points at issue, a Royal Commission was appointed in the spring of 1888. The report of the commission, issued in May 1889, propounded a scheme for the reorganisation of the university which offered harsher terms to the senate than those that were rejected in 1887, without, however, satisfying the two great London colleges. The senate therefore reopened negotiations with these colleges, and offered still more extensive concessions than those prescribed by the commission. The University of London Act of 1898 made pro-

vision for its reconstitution as a teaching body, and for the appointment of a commission, whose statutes for the reorganisation and regulation of the university received the royal sanction in 1900. The senate now consists of a chancellor, a chairman of convocation, and fifty-four persons nominated by the crown, by convocation, by University College, King's College, the Royal Colleges of Physicians and Surgeons, Lincoln's and Gray's Inns, and the Inner and Middle Temples, by the Incorporated Law Society, and the Guilds Institute. Convocation consists of the chancellor, the vice-chancellor, all members of the three standing committees of the senate not already on convocation, and the registered graduates. Members of convocation, not being women or otherwise disqualified, constitute the parliamentary constituency (4000 in number). Instead of four there are now eight faculties—Theology, Arts, Laws, Music, Medicine, Science, Engineering, and Economics and Political Science. The faculties consist of university teachers, nominated by the Royal Commission, appointed by the university, and admitted by the senate. The schools of the university in 1900 were in the several faculties, or in one or more faculties: University College and King's College, in London, for all the faculties; Hackney College, New College (Hampstead), Regent's Park College, Cheshunt College, the Richmond Wesleyan College, and the London College of Divinity in theology; Holloway College and Bedford College in arts and science; the Royal College of Science in its one faculty; the South-eastern College of Agriculture at Wye; the medical schools of St Bartholomew's, the London, Guy's, St Thomas's, St George's, the Middlesex, St Mary's, Charing Cross, and Westminster Hospitals, and the London School of Medicine, for women; the Central Technical College of the City and Guilds of London Institute in engineering; the London School of Economics and Political Science in that faculty. The Royal College of Music and the Royal Academy of Music were not willing to become a school of the university save on inadmissible conditions; the commissioners therefore excluded also Trinity College and the Guild Hall School of Music, but recognised teachers of the three first-mentioned institutes as teachers of the university. They regretted that, guided by the Gresham Commission, they felt precluded from recognising the training colleges of London and its neighbourhood, as giving too much prominence to elementary teaching and to training for elementary teaching. Boards of studies consisting of teachers of the university and others are appointed by the senate to deal with groups of subjects. Thirty-two boards were provided for. The series of examinations for both sexes begins with matriculation, from which there is no exemption. Numerous exhibitions and other prizes are open to competition among honours candidates at many of the examinations. The regulations for these examinations and all bylaws are laid down by the senate, often upon the recommendation of colleges, examiners, or convocation; but no such rules are valid until they have been approved by the Home Secretary.

The growth of the university, at least in point of numbers, was rapid, especially after 1858. In 1838 there were 23 candidates for matriculation, of whom 22 passed; in 1858 there were 299 candidates, of whom 249 passed; in 1895 there were 3120 candidates, of whom 1710 passed; and the increase in the higher examinations has been on a similar scale. For the first thirty years the university had no fixed abode; but in 1868 the government ordered the erection of a new building, specially for it, in Burlington Gardens, W.; this was completed, opened by the Queen, and occupied in 1870. In 1900 arrangements were made and sanctioned by

the Treasury for housing the newly reorganised university in parts of the buildings of the Imperial Institute at South Kensington. As the university was the child of the government of 1836, both that and succeeding governments recognised the duty of supporting it; and year by year an estimate of expenses has been laid before parliament, and covered by a vote. On the other hand, all the receipts from fees have been claimed by the Exchequer; but up to the year 1876 these scarcely equalled a third of the total cost of the university. Owing, however, to the increase in the number of candidates, the fees received in 1889 (nearly £15,000) more than covered the whole vote for working expenses, leaving the Treasury chargeable with the costs of the building, stationery, &c., altogether equal to perhaps another £8000. The grant in 1890-1900 was £18,840.

UNIVERSITY COLLEGE, at the time of the re-constitution of the university, had in its faculties of arts and laws, and of science, forty-four professorships, and in that of medicine twenty more. Its governing bodies, under president and vice-president, are a council and a senate; the latter comprising all the professors. King's College (q.v.) is the subject of a separate article.

On the re-constituted university see besides the Calendar the reports of the Commission, and the statutes, Professor Karl Pearson's *The New University of London* (1893), discussing the various schemes till then proposed.

London, a city and port of entry, capital of Middlesex county, Ontario, is situated at the junction of the two branches of the Thames, 116 miles by rail SW. of Toronto. It is a handsome city, regularly built, and contains many fine buildings; and the aim of its founders is visible in the names of the principal streets—Pall Mall, Oxford Street, Piccadilly, Cheapside, &c.—as well as of the river, which is crossed by a Westminster and a Blackfriars Bridge, and of the Covent Garden Market, Hyde Park, and St Paul's Cathedral. The centre of a rich agricultural district, and connected by railway with all parts of Canada, London carries on an extensive trade in the produce of the country; while it has also large petroleum refineries, and many foundries, mills, tanneries, and other manufactories. It has several colleges (including the Western University) of good standing, lunatic and orphan asylums, a convent, and a hospital; and its white sulphur-springs attract many invalids. London is the seat of Anglican and Roman Catholic bishops, and returns one member to parliament and one to the provincial legislature. Pop. (1881) 49,746; (1891) 31,997.

London Clay. See Eocene SYSTEM.

Londonderry, a maritime county of the province of Ulster, in Ireland, 40 miles long by 34 broad, is bounded N. by the Atlantic, and elsewhere by Antrim, Lough Neagh, Tyrone, and Donegal. Area, 816 sq. m. Pop. (1831) 222,174; (1861) 181,296; (1881) 164,991; (1891) 152,009, of whom 67,748 are Catholics, 48,936 Presbyterians, and 27,730 are Protestant Episcopalians. The surface rises the farther one travels inland, Mount Sawell, on the southern border, being 2236 feet high. The coast line (30 miles long) is generally bold and precipitous; but the shore of Lough Foyle is in most places an unvarying plain, large tracts having been reclaimed. The river Bann from Lough Neagh forms part of the eastern border of the county. The river Foyle intersects its western extremity. The principal crops are oats, potatoes, flax, and turnips. Thirty-seven per cent. of the area is permanent grass, and a large proportion of the cultivated soil is meadow land and clover. Linen (shirt-making) is the staple industry. The fisheries, both off the coast and in the

lakes, are valuable. The county returns two members to parliament, and the county town, Londonderry (q.v.), returns one. The other towns are Coleraine and Limavady. The county owned in ancient times the sovereignty of the O'Neil sept. It was subjected to English authority in the end of Elizabeth's reign. In 1609 the confiscated estates of the native Irish chieftains were granted by the crown to the corporation of London, the management being vested in the Irish Society, a body twenty-six in number, elected by the common council, one-half retiring each year. Portions of the county were assigned to twelve of the livery companies. At the present time the Irish Society and half a dozen of the London companies own more than one-fourth of the entire county; but several of these last, notably the Drapers' Company, have sold their estates to the occupying tenants under the Ashbourne Act.

Londonderry, or DERRY, a city, seaport, and parliamentary borough in the north of Ireland, is situated on an eminence overlooking the river Foyle, 3 miles from its mouth and 18 miles from the entrance to Lough Foyle, by rail 163 miles NNW. of Dublin and 95 NW. of Belfast. Pop. (1851) 49,888; (1871) 24,242; (1881) 29,162; (1891) 33,200. Londonderry grew up round a monastery founded here in 546 by St Columba. It was frequently held by the Danes from the 9th to the 11th century. The town formed part of the escheated territory granted to the London companies, and under their management rose to some importance, and was strongly fortified. In the Irish war of the Revolution thirteen Londonderry apprentices closed its gates against James II.; and the townsfolk, shouting 'No surrender,' manned the walls. The 105 days' siege that then ensued, from April to August 1689, is one of the most celebrated events in Irish history, and its memories are among the most stirring causes of party animosity. The walls still surround a part of the town one mile in circumference, but now the greater part of the city lies outside them. The four main streets diverge from a square in the centre of the city called the Diamond. The left bank of the river is connected by an iron bridge, 1200 feet in length, with an extensive suburb called Waterside. The Protestant cathedral dates from 1633; it was restored in 1886. A handsome Roman Catholic cathedral, the courthouse, guildhall (erected in 1890 at a cost of £20,000), harbour-offices, post-office, custom-house, and banks are the other chief buildings of note. The historical events of the siege are commemorated by a triumphal arch—one of the gates of the city—erected in 1789 and a column in honour of the Rev. George Walker, who was governor of the city and the soul of the defence. The Presbyterian theological Magee College was founded in 1865. The industrial establishments include linen (shirt-making) factories, distilleries, iron-foundries, flour-mills, and shipbuilding-yards. There are valuable salmon-fisheries in Lough Foyle. The harbour is deep, extensive, and safe. The great Atlantic liners (Allan, Anchor, and State) stop at the entrance to Lough Foyle both in going to and coming from America. The imports (which include grain, flour, timber, and spirits) reach an annual average value of £76,480; the exports, chiefly agricultural produce, vary in value from £6000 to £350,000 annually. This is exclusive of an extensive coasting trade. Londonderry returns one member to the House of Commons. See John Hempton's *Saga and History of Londonderry* (1861).

Londonderry, MARQUIS OF. See CASTLE-REGUL.

London Pride. See SAXIFRAGE.

Long. Loch, a beautiful Scottish sea-loch, striking off from the Firth of Clyde, 17 miles north-north-eastward between the counties of Argyll and Pembrokeshire, and 3 furlongs to 2 miles broad. It sends off Loch Gail (q.v.); is flanked by steep and fantastic mountains, 2000 feet high; and at Arrochar, near its head, approaches to within $\frac{1}{4}$ mile of Tarbet on Loch Lomond. A railway from Helensburgh to Fort William, commenced in 1889, skirts its eastern shore. Since 1862 the loch has been deified with the dredgings from the Clyde at the rate of 1,250,000 tons a year.

Long. George, scholar, was born at Poulton, Lancashire, 4th November 1800, and from Macclesfield went up in 1818 to Trinity College, Cambridge. In 1821 he was bracketed with Malden and Macanlay for the Craven scholarship; in 1822 graduated as a wrangler and senior Chancellor's medalist, and in 1823 was made Fellow of his college. In 1824 he accepted the chair of Ancient Languages in the university of Virginia, United States; but he returned to England in 1828 to become Greek professor in London University. Subsequently, at different periods of his life, he taught as professor of Latin at University College, London (1842-46), reader in jurisprudence and civil law to the Middle Temple (1846-49), and classical lecturer at Brighton College (1849-71). He had a share in founding the Royal Geographical Society (1830), and from 1831 took an active interest in the Society for the Diffusion of Useful Knowledge, writing books for its library and editing its *Journal of Education*. But the *magnum opus* of his life was the editing (1833-46) of the *Penny Cyclopædia*, to which he was one of the most valuable contributors. Besides this he edited the *Biographical Dictionary* (1842-44), Knight's *Political Dictionary* (1845-46), the excellent *Bibliotheca Classica* series, and many admirable versions of classic authors. He also translated *Selections from Plutarch's Lives*, *Thoughts of M. Aurelius* (1862), and *Discourses of Epictetus* (1877), contributed extensively to Smith's Classical Dictionary, and wrote *Decline of the Roman Republic* in 5 vols. He died 10th August 1879.

Longan (*Nephelium Longan*), one of the finest of fruits, of the same genus with the Litchi (q.v.), but reckoned superior to it.

Long Branch, a fashionable bathing-place of New Jersey, on the Atlantic Ocean, some 30 miles S. of New York city and 13 S. of Sandy Hook. Here are many costly cottages, occupied only in summer. Pop. 7231.

Longchamp, the racecourse, lying on the south-west side of the Bois du Boulogne, on the west of Paris, where the race for the *Grand Prix* is run. It was formerly the custom for the great folk of Paris to drive out in this direction, as far as the old nursery of Longchamp (founded in 1260), during the week preceding Easter.

Longchamp, WILLIAM DE, a Norman of low birth, and a favourite of King Richard I. The latter, on his accession, made Longchamp Bishop of Ely, and in 1190 joint justiciar of England with Hugh de Puisey; in 1191 he was likewise made papal legate. But his ambition, his arrogance, and his unpopular manners, combined with his oppressive taxation, made him greatly disliked, and Richard was obliged to send him back to Normandy. He regained the royal favour by his energy in raising the king's ransom; his reward came in the appointment of chancellor. He died in 1197, having been overthrown by the parties of John, Godfrey Plantagenet, the Barons, and Walter de Coutances, some time before. He disliked the English, and displayed his contempt for them in the coarsest way, declaring that he did not

understand their language and would not speak it. Nevertheless he was a clever and energetic ruler, administered strict justice, and was faithful to his prince. See the French monograph by L. Boivin-Champeaux (Eyreux, 1886).

Longevity. A term which in popular usage has come to mean great length of life instead of merely length of life; therefore, after a discussion of centenarianism, will follow a short account of the general theory.

The wide-spread belief that there are cases on record of persons living to the age of 150 or even 200 years, and that centenarians are numerous, is owing to a general love of the marvellous backed by superstition, and also to the fact that noted writers, such as Haller the physiologist, accepted and reasoned upon many such stories. But in 1862 Sir G. C. Lewis wrote in *Notes and Queries* an article in which he professed disbelief in any case of a life exceeding 100 years; he pointed out that neither the peerage and baronetage nor the books of insurance companies contained any evidence of such, and further that the current stories were nearly all of persons of humble rank, careless of registration, so that their statements could not be verified. This led to great correspondence in *Notes and Queries* and elsewhere; the editor, Mr Thoms, took the matter up, went into it with great care, and compiled his work on longevity which is authoritative. He examined many stories of very ancient persons, showing them to be baseless; while as to stock historical cases of Thomas Parr, Henry Jenkins, and the Countess of Desmond, reputed to be 152, 169, and 140 respectively, he found that there was no satisfactory evidence. For Jenkins there was none save his own assertion. Parr was before his death a celebrity, the poet Taylor wrote his life with numerous dates of various events, and Harvey in his post-mortem report repeats the popular hearsay—this is all the evidence to be found. As to the Countess of Desmond, Mr Thoms gives conclusive reasons for believing that the stories from which her age is deduced really relate to two, if not three, ladies of that title.

The evidence which is often said to exist in the registers has been proved in many cases to refer to two persons of the same name; and in one noted case, Carr of Shoreditch, said to be 207, the 2 was found to have been written upon the top of L. As to tombstones, the age 309 in one case being certainly some village chiseller's manner of writing 39, will serve as an example. In fact, a review of the evidence shows that while Lewis was right in renouncing his contention that no certain instances of a greater age than 100 existed, a belief in lives of 150 years is no longer possible. It remains to add that there is no scientific evidence to support the belief that the length of human life was once much greater than it is in modern times, nor the converse opinion that the length of life has been increasing since the Psalmist cited it at three score and ten. All that we certainly know is that in civilised countries the average length of life has been for many obvious reasons emphatically on the increase for several centuries.

There is another question of common interest: How shall we live to attain great age? There have been many teachers with many tads; but from the varied modes of life of those who have lived long it is probable that as no amount of feeding will make a man tall who is destined to be short, so no amount of care will prolong the life of one destined to die young. St Antony lives a life of excessive austerity and he dies at 105. Titian is all his life about a court and he paints a fine picture at ninety-six.

Statistics have been accumulated, and such general facts as that married people live longer

than unmarried, that women live longer than men, and that the clergy have longer lives than other professional men have been established; but deductions from facts such as these are unsafe in the present state of science—the whole subject is too complex.

Turning now to the general question of the length of life of plants and animals, we may notice at the outset that the unicellular organisms cannot and do not die after the fashion of those in which death seems to be the necessary price paid for a 'body'; that increase of intelligence naturally tends to lengthen life; that perfecting of the reproductive processes has the same result; that many males live much longer than their mates, and so on. More than one popular adage makes size the criterion of longevity, but it is at most a partial factor; for while an elephant lives 200 years and a mouse only 6, carp and pike may attain the age of the former, and one of Sir John Lubbock's queen ants surpassed the mouse by almost 9 years. A horse often lives 40 years, but the donkey may exceed this, while both are outstripped by the golden eagle (60), by an almost centenarian captive raven, by a toad, or even by Sir John Dalyell's sea-anemone 'Grannie,' which, after its removal from the Firth of Forth, lived in an aquarium for 59 years—from 1828 till 4th August 1887. Florens supposed that the length of life was five times the period of growth, but this does not hold even approximately for the majority of animals. Rapidity of life is another factor; thus the sluggish amphibian is long-lived, and trees may survive over 2000 years, in contrast to the transient life of many of our rapidly growing, brightly flowering annuals, or the yet more ephemeral existence of many intensely active insects. But on the other hand ants and bees often live for many years, and some of the most active birds attain a great age. According to Weismann, 'Duration of life is really dependent upon adaptation to external conditions; its length, whether longer or shorter, is governed by the needs of the species, and is determined by precisely the same mechanical process of regulation as that by which the structure and functions of an organism are adapted to their environment.' In other words, he maintains that the duration of life is fixed by natural selection; that, given the rate of reproduction and the average mortality, the length of life characteristic of any species is such that the numbers under fixed conditions will remain constant. His essay is suggestive, but natural selection is at present called upon to explain too much; for instance, he believes that that principle has determined that no creature shall long survive the period at which its reproductive activity ceases; but he does not seem to observe that a creature may not have sufficient energy for reproduction and yet quite enough to maintain life in an ordinary way for many years, as is notably the case with women. It may be noted that the unicellular animals in natural conditions probably never or hardly ever die a natural death; they may be eaten up, but, violence apart, they are virtually immortal; they divide, but in this there is no death. In fact, death probably began with the multicellular organisms, as the price paid for a body.

For general aspects of human longevity, see W. J. Thoms, *Longevity of Man*; G. M. Humphrey, *Old Age*; Barn Bailey, *Modern Methuselahs*. For general theory, see E. Ray Lankester, *Comparative Longevity*; and August Weismann, *Essays upon Heredity* (trans. by Foulton, &c.), which contain abundant references to other literature on the subject. See also INFUSORIA, PROTOZOA, REMIOPROCTERA, INSECTS; F. Hillebrand, *Die Lebensdauer, etc. der Pflanzen*, in Engler's *Botan. Jahrbuch*, Bd. ii. (Leip. 1881); and, for further literature, Giddes and Thomson, *Evolution of Sex* (1889).

Longfellow, HENRY WADSWORTH, born in Portland, Maine, U.S.A., February 27, 1807, and died in Cambridge, Massachusetts, Copyright 1800 in U.S. March 24, 1882. He inherited the best blood of the two Massa- By J. B. Lippincott Company.

chusetts colonies—Pilgrim and Puritan. His parents were in easy circumstances, and gave him the best education which the schools of the time afforded. At the early age of eighteen he graduated from Bowdoin College in Brunswick, Maine, in the class with Hawthorne, his life-long friend. His rank in college was high, especially in languages, ancient and modern. His translations then and afterward were noted for a felicity and point quite beyond the reach of ordinary scholars. In 1826 the trustees of the college sent him to Europe to qualify for the chair of Foreign Languages and Literatures; and he spent a year and three-quarters with this end in view in France, Spain, Italy, and Germany.

After his return home he married in 1831 Miss Potter of Portland, who died in Rotterdam in 1835, while they were making a tour in Europe; she is commemorated in the touching poem, *The Footsteps of Angels*. He had written poems while at college, and published them in magazines, chiefly in the *United States Literary Gazette*. His first book, omitting his numerous linguistic works, was a version of *The Captivity of Don Jorge Manrique*, a grave and stately poem, in itself probably inferior to Longfellow's fortunate translation, *Outre Mer*, an account of his first tour, appeared in 1835; and *Hyperion*, which is a journal of a later trip, in 1839. Both are interspersed with translations of German poems, and both have a permanent value as indicating the development of the poet's mind and art.

In November 1836 he became professor of Modern Languages and Literature in Harvard College, and held the chair nearly eighteen years, being succeeded by Mr Lowell. *Voices of the Night*, his first book of original verse, appeared in 1839. This gave to the world a distinctly new impression of tenderness, manly sentiment, and melody, and to the author an assured place among poets. The impression was deepened by the *Ballads* (1841), including 'The Skeleton in Armour,' 'The Wreck of the Hesperus,' 'The Village Blacksmith,' 'Excelsior,' and others. *Poems on Slavery* appeared in 1842. By this he gave evidence of his moral convictions and courage, for at that time anti-slavery poets and orators were unpopular to the last degree. In 1843 was published *The Spanish Student*, a drama slight in substance, but full of movement and gaiety, and brilliant in local colour.

He made a third visit to Europe in 1842, and on his return the following year was married to Miss Frances Appleton of Boston, a beautiful and accomplished woman, the mother of his five children. He made collections of poems, including some of his own translations: *The Wulf* (1845), *The Estuary* (1847)—both now very scarce—and *The Poets and Poetry of Europe* (1845). This last is a large and important work, in which he was aided by his friend C. C. Felton. *The Belfry of Bruges and other Poems* appeared in 1846. In the following year he gave to the world what is probably his most popular poem, *Evangeline*, a tale of the French exiles of Acadia, known and admired by readers of every degree, and translated into most modern tongues. Opinions may differ as to the use of the hexameter measure; but, while critics debate, the vital interest of the pathetic story seizes upon all hearts. *Korranough*, a prose tale, appeared in 1849. *The Seaside and the Fireside* (1850) contains 'The Building of the Ship,' one of the finest of his poems, which has a great hold upon the people of the United States on account of the

grand patriotic invocation with which it closes. *The Golden Legend* (1851), based upon an ancient German ballad, *Der Arme Heinrich*, by Hartmann von Aue, is a striking poem, medieval in tone and well sustained, though not a masterpiece. His genius is shown at its best in *Hiawatha* (1855), founded upon traditions and legends of the North American Indians. The light and tripping measure, the simplicity of phrase, and the well-calculated repetitions at first give an impression of artlessness, almost of baldness; but whoever reads the poem with enlightened eyes finds, under this easy flow of words, a series of poetic conceptions, the suggestion of noble and enduring images, and the mastery of just expression. *The Courtship of Miles Standish* (1858) is a story in hexameters of the early days of the Plymouth colony in Massachusetts. To the people of New England this poem has an inexpressible charm on account of its historical associations: it is a mirror of the life of the Pilgrims. The story is interesting in itself, and is told with easy grace. The poet was descended from the Priscilla of this poem, whose well-known question, "Why don't you speak for yourself, John?" is the keynote of the book. *Tales of a Wayside Inn* is a poem which appeared in parts, in different volumes (1863, 1872, 1874)—its plan suggested evidently by the *Canterbury Tales*. The Inn was in Sudbury, Massachusetts, famous a century ago, and the poet has gathered there a company of well-known men whom he portrays, and who in turn tell stories, some of which are from Boccaccio and other early writers, and some original. *Flower-de-Luce* (1867), though not so famous as other collections, shows in its twelve short poems some of the poet's most exquisite workmanship. *The New England Tragedies* (1868), in blank verse, treats mainly of the Salem witchcraft in the latter part of the 17th century. The next work was a complete and faithful translation of the three parts of Dante's *Divine Comedy* (1867-70). *Christos, a Masque*, being the gospel story in blank verse, appeared in 1872. This was afterwards printed with *The Golden Legend* and *The New England Tragedies* consecutively. *Three Books of Song*, containing the conclusion of *Tales of a Wayside Inn*, *Ambar Macabarius*, &c., was published in 1872; *Aftermath*, in 1874; *The Masque of Pausanias*, in 1875. This last volume contains a poem, "Morituri Salutamus," written for the fiftieth anniversary of the poet's graduation from college. The occasion, which was noticed throughout the United States, was most impressive and affecting. *Keramos* (1878) and *Ultima Thule* (1880) were the last of the long series. No mention is made of his many contributions to magazines and reviews, *Poems of Places*, a collection undertaken by the poet without too much thought of the magnitude of the task, reached 31 volumes.

He paid a last visit to Europe in 1868-69, and was received in England with honour and love. The greater and most fruitful part of Longfellow's life was passed at Cambridge, Massachusetts, where he lived in a stately colonial house which had been the headquarters of Washington during the siege of Boston, and which remains as he left it. His striking features, his full beard, and his massive head, crowned with abundant silvery hair, gave him a singularly noble look. He was free from the faults of many literary men never exhibiting envy or jealousy, and preserving always a serenity and amiability that won the hearts of all who met him. His relations with his contemporaries—Emerson, Hawthorne, Holmes, Lowell, and Agassiz—were intimate and hearty, and the literary society in which he moved was simple and charming.

He began as a translator, and in many respects his translations were his best work. He was

not a minute or methodical observer, but was open to all the impressions of nature, and his verse has a general rather than a particular truth in regard to the external world. He was not a profound student of human nature, and seldom throws any startling light into its secret rifts and contradictions; but he knew mankind in general, especially in their tender fibres, their interior life of alternate hope and depression, and in all that makes the delight of home. Of modern poets he is the one who has best expressed the feelings of natural men in regard to love and maternity, peace and goodwill, death and the future life. The wide gamut and perfect accord of his sympathies have made him the poet of the people without losing the regard and the respect of the cultivated few. How large a place he fills can best be estimated by considering the void that would be left if the *Voices of the Night*, *Evangelium*, and *Hiawatha*, and the long succession of poems could be blotted out from the memories of men. He did not consider himself one of the grand old masters, nor one of

the birds sublime,
Whose distant footsteps echo
In the corridors of Time.

If he was not great among the half dozen great poets, he was among those who have made the best use of their talents. The faculty of full and just, as well as of delicate and suggestive expression, developed by patient study, gave to his thoughts and sentiments a value and currency for which greater men have sought in vain. After all deductions there remains a great and almost incomparable treasure in his varied and beautiful works.

See his Life by his brother, the Rev. Samuel Longfellow (3 vols. 1886-87); and the memorial volume published shortly after his death by the present writer.

Long Firm. See FRAUD.

Longford, an inland county of Leinster, Ireland, bounded on the W. by the Shannon and on the SW. by Lough Ree. Its maximum length is 29 miles, its maximum breadth 20. Area, 421 sq. m. Pop. (1841) 115,491; (1861) 71,694; (1881) 61,009; (1891) 52,647. 91 per cent. Roman Catholics. The surface is for the most part flat, and the soil on the whole fertile, though extensive tracts of bog exist. Oats and potatoes are the principal crops; 51 per cent. of the area is permanent grass. The county is studded with numerous small lakes, and is crossed by the Royal Canal. Marble of good quality is found. Linen and coarse woollens are manufactured, and large quantities of butter are made. The county returns two members to parliament. Longford anciently formed part of the kingdom of Meath, and was included in Henry II.'s grant to Hugh de Lacy. It was erected into a county in 1564. The antiquities are of much interest, the islands of Lough Ree being especially rich in monastic remains.—**LONGFORD**, the county town, on the river Canlin and a branch of the Royal Canal, 76 miles NW. of Dublin by rail. Its best building is the new Roman Catholic cathedral (1840-93). Pop. 3827.

Longinus, DIONYSIUS CASSIUS, a famous Platonic philosopher and rhetorician of the 3d century, born at Emesa or at Athens, about 213 A.D. He studied at Alexandria, under Ammonius, and he himself taught rhetoric in Athens, where the famous Porphyry was a pupil. Later he settled at Palmyra, and became chief counsellor to the celebrated Queen Zenobia, whom he abetted in her determination to shake off the Roman yoke. For this he was beheaded as a traitor, by command of the Emperor Aurelian, 273 A.D. The only work of his that remains is the famous treatise *Peri Hypsion*

(*On the Sublime*), the authenticity of which has been impugned. There are editions by Egger (1837) and Otto Jahn (1867). See Vaucher's *Études critiques sur le Poète du Sublime* (Geneva, 1854).

Long Island, an island which forms three counties of the state of New York, bounded N. by Long Island Sound, E. and S. by the Atlantic Ocean, and W. by the East River (spanned by the Brooklyn suspension bridge). It is 115 miles long, and from 12 to 24 in width, with an area of 1682 sq. m. On its south shore is a series of lagoons, the largest 40 miles long and 5 or 6 wide. A line of low hills rises in the interior to 384 feet. There are numerous small lakes and watercourses, and market-gardening especially is carried on with success for the most part by Germans. But much of the island is waste land or forest, and such popular watering places as Coney Island (q.v.) are planted among deserts of sand. There is still a good deal of game, and the fisheries and oyster-beds are very valuable. The island has nearly 100 miles of railway. The principal towns are Brooklyn, Long Island City, and Flushing. Creedmoor (q.v.) is the principal American rifle-range. Long Island was the scene of a campaign in 1776, in which Sir Henry Clinton finally compelled Washington to evacuate the island. Pop. (1870) 540,648; (1890) 1,029,097. See NEW YORK.

LONG ISLAND SOUND, lying between Long Island and the mainland of New York and Connecticut, is from 2 to 20 miles wide, and from 75 to about 200 feet in depth. It is navigated by an immense number of coasting-vessels and steamers, and receives the Thames, Connecticut, Housatonic, and other rivers on its northern shore.

Long Island City, on Long Island, separated from New York city by the East River and from Brooklyn by the navigable Newtown Creek, was formed in 1870 from five villages. It is a railway terminus, and has some extensive manufactories, including oil-refineries, and carpet and piano works. Pop. (1880) 17,129; (1890) 30,396.

Longitude. See LATITUDE.

Longland, WILLIAM. See LANGLAND.

Longmans, a well-known firm of London publishers, whose name has been associated with high class literature for five generations. Thomas Longman (1699-1755), descended from a line of Bristol merchants, was bound apprentice to John Osborne, bookseller, Lombard Street, whose daughter he married. The earliest title page bearing the imprint of T. Longman is the Countess of Moreton's *Daily Exercise* (1665). The name of T. Osborne also appears on the title. Longman bought the business of William Taylor, publisher of *Robinson Crusoe*, conducted in Paternoster Row, and in 1726 moved there, the present site of the firm. As was the custom at that time, the first Longman held shares in many important publications, such as Boyle's *Works*, Ainsworth's *Latin Dictionary*, the *Cyclopaedia* of Ephraim Chambers, and Johnson's *Dictionary*. His nephew and successor Thomas Longman (1731-97) brought out a new edition of Chambers's *Cyclopaedia*. Under Thomas Norton Longman (1771-1842) the firm reached a high point of literary and commercial success, and from time to time fresh blood was introduced in the partners, Messrs Hurst, Rees, Orme, Brown, Green, and Roberts. When the government was about to impose an additional duty on paper, subsequent to that of 1791, the Longman firm used such arguments as averted that calamity. At that time the house had nearly £100,000 sunk in various schemes. Lindley Murray's *Grammar* was a good property, while the firm had a literary connection with Wordsworth, Southey, Coleridge, Scott, Moore (who received £3000 for *Lalla Rookh*),

Sydney Smith, and others. Byron's *English Bards* was rejected because of its severe handling of the Lake poets, whose works were issued by Longman. After Constable's (q.v.) failure in 1826 the *Edinburgh Review* became the property of the firm. Some of the foremost authors of the day were contributors to Lardner's *Cabinet Cyclopaedia* (1829-46) in 132 volumes. The next guiding spirits of the firm were Thomas Longman (1804-79), eldest son of T. N. Longman, who issued under his special care a beautifully-illustrated New Testament, and William Longman (1813-77), the third son. The latter figured as an author and historian, and printed privately a *See Works' Tour in Switzerland*, contributed to the *Alpine Journal*, was a president of the Alpine Club, and wrote *Lectures on the History of England* (1859), *History of the Life and Times of Edward III.* (1869), and *History of the Three Cathedrals of St Paul* (1873). The event of this generation was the publication in succession of Macaulay's *Lays* (1842) and *Essays* (1843), and *History*. The famous cheque for £20,000 paid to Macaulay 'on account' of his share of the profits of the third and fourth volumes for the first few months (1855) is still preserved. The absorption of the stock-in-trade and business connection of the Parkers in 1863 introduced the works of J. S. Mill, Froude, and Sir Comewall Lewis. The *Traveller's Library* was an excellent cheap series. The partners of the fifth generation are now Thomas Norton Longman and George Henry Longman, sons of Thomas Longman, and Charles James Longman and H. H. Longman, sons of William Longman. One of the earliest ventures of this generation was Lord Beaconsfield's *Endymion*, for which they gave the author £10,000. Lord Beaconsfield's other works had come into possession of the firm in 1870, when they published *Lathair*. Since the stoppage of *Fraser's Magazine* a sixpenny magazine has been published by the house *Longmans*. A partner, Thomas Brown, left in 1869 £10,000 each to the Booksellers' Provident Retreat and Institution, in which the firm has since been much interested. In 1890 Rivington's business and stock was bought by the Longmans. Rivington's was the only business which exceeded that of the Longmans in antiquity, and by this purchase a friendly rivalry of over 150 years came to an end.

Long Parliament, the name by which the fifth parliament summoned by Charles I. is known. It succeeded the Short Parliament, dissolved after three weeks, and met November 3, 1640. It began its work by reversing all the tyrannical and illegal acts of the past eleven years, with the abolition of the Star Chamber and High Commission, and the impeachment of Strafford; while it secured itself by an act that it could not be dissolved without its own consent. Just before Charles I.'s trial it was 'purged' by Colonel Pride of 96 members displeasing to the army, and the remnant the 'Rump'—continued to sit until its members were turned out by the Lord General Cromwell, April 20, 1653. The 'Rump' was recalled by the officers on the failure of Richard Cromwell to maintain his authority, and of the 160 members who had continued to sit after the king's death about 90 returned to their seats. Proving once more displeasing to the army, they were again turned out by General Lambert. They were restored amid the dissensions of the officers, as the only body in the country having any kind of legal authority, and, on the motion of Ashley Cooper, the members ejected by 'Pride's Purge' returned to their seats. After issuing the writs for a new election it dissolved itself, March 16, 1660. Thus ended the Long Parliament, which, twice expelled and twice restored, had lasted for twenty years.

Longridge, a small manufacturing town of Lancashire, 6½ miles by rail N.E. of Preston, on the side of the Longridge Fell, which extends 5½ miles N.E. to the boundary of Yorkshire. Here are Preston reservoirs, and manufactures of cotton goods, nails, &c. Pop. 4191. See Tom C. Smith, *History of Longridge* (1889).

Longships. See SCILLY ISLANDS.

Longstreet, JAMES, an American general, born in South Carolina in 1821, graduated at West Point in 1842, fought in the Mexican war, and in 1861 entered the Confederate service. He took part in both battles of Bull Run, that of Williamsburg, those around Richmond, and at Fredericksburg, Gettysburg, Chickamauga, and the Wilderness. Known to the soldiers as 'Old Pete,' he was considered the hardest fighter in the Confederate service. He was minister to Turkey in 1880-81.

Longton, a municipal borough of Staffordshire, is situated at the southern extremity of the Potteries, 2½ miles S.E. of Stoke-upon-Trent, and included within its parliamentary boundary. It was incorporated as a municipal borough in 1865, and its municipal boundaries were extended in 1883. The prosperity of the town is due to the manufacture of china and earthenware, though potting, brewing, and brick-making are also carried on. Close by are ironworks and collieries. Pop. (1851) 15,149; (1881) 18,620; (1891) 34,327.

Longneuil, BARONY OF. See LE MOYNE.

Longueville, DUCHESS OF (1619-79), the soul of the Fronde (q.v.).

Longwood. See ST HELENA.

Longwy, a small town and fortress in the extreme north of the French department of Meurthe-et-Moselle, 18 miles W.S.W. of Luxemburg. The fortress capitulated to the Prussians in 1792, 1815, and 1871. Pop. 5605.

Lönnrot, ELIAS, a great Finnish scholar and folklorist, was born at Sammatti in Nyland, 9th April 1802. He studied medicine, and practised for twenty years in Kajana, but in 1853 on Castrén's death succeeded to the chair of Finnish at Helsingfors, from the duties of which he retired in 1862. He helped to found the Finnish Literary Society at Helsingfors in 1831, and made throughout his life journeys through the whole of Finland, as well as the neighbouring parts of Lapland, Russia, and Sweden, in order to collect the remains of poetry and tradition lingering among the people. The first fruit of these inquiries was a collection of more or less ancient Finnish folk songs, *Kantelet* (1829-31), after which followed in 1835 the great epic of the *Kalevala*. His *Kanteletar* (1840) was a collection of lyrical folk-poetry; *Saamelaskuja* (1842), of proverbs; *Aseautuksien* (1844; 2d ed., much enlarged, 1861), of riddles. No less important were the contributions to Finnish philology which his profound knowledge of the popular dialects enabled him to make. His latest work was the great Finnish Dictionary (2 vols. 1866-80). He died at his native place, 19th March 1884.

Lons-le-Saunier, capital of the French department of the Jura, stands in a basin of the Jura Mountains, surrounded with vine-clad hills, 42 miles by rail E. by S. of Châlon-sur-Saône. It was founded in the 4th century, when its salt-springs were discovered; these are still in use for bathing, and salt is manufactured from them. Melons, white wine, and mathematical instruments are produced. Pop. (1872) 10,628; (1891) 12,427. Rouget de Lisle, the author of the *Marseillaise*, was born here.

Loo, a round game at cards, formerly called *hundred*. About five players make the best game. Each puts down a stake to form a *pool*.

The dealer stakes double. Three cards are dealt to each player as at whist, and an extra hand, called *miss*. The top card of the stock is then turned up for trumps. Each player in rotation looks at his hand, and *declares* whether he will play, resign, or take *miss*. If he takes *miss* he must play it. The declared players play one card each in rotation, the cards thus played forming a *trick*. The highest whist card wins, or if trumped, the highest trump. The winner of a trick leads to the next. The cards played remain face upwards before the players. If the leader holds ace of trumps (or king when ace is turned up), he must lead it; if he has two trumps, he must lead one. He is not obliged to lead the highest, unless (a) it is the ace (or king, ace being turned); or (b) there are only two declared players. Subsequent players must follow suit, and must head the trick if able. If not able to follow suit, and holding a trump, they must head the trick by trumping. The winner of the first trick must lead a trump if able. In other respects the play is as at whist. The winners of the tricks divide the pool, one-third for each trick. If only one declares to play, the dealer plays *miss* for the pool; tricks won by *miss* remaining in to augment the next pool. If only the dealer declares to play, he takes the pool. If each declared player wins a trick it is a *single*, and a fresh pool is staked as before, the deal passing to the left of the previous dealer. If any declared player fails to win a trick, he is *looted* the amount in the pool; the player who now deals puts in a single stake, no one else contributing. It is advisable to fix a limit beyond which a player cannot be looted. If there is more in the pool, the player is only looted up to the limit. There are no recognised laws of *loo*. The Bleenheim Club, for many years the best authority on *loo*, issued laws for the use of the members. These laws are republished in *Round Games at Cards* (De La Rue & Co.).

Loo, THE. See APPLDORF.

Loochoo (otherwise *Liukiu* or *Loo Kin*), a group of thirty-seven islands, of which the most considerable are Oshima and Okinawa. The islands extend at irregular intervals in a south-westerly direction from Kyūshū in Japan, and form the prefecture of Okinawa in that empire. Their aggregate area is 1863 sq. m., and the population amounts to only 160,000. Linguistically and ethnically the Loochooans are almost identical with other Japanese, and their manners, customs, and religious observances (Shintoist) bear a close affinity. They were formerly subject to the lord of Satsuma, and paid an annual tribute, having been completely subjected in 1609. China has made a claim upon the islands, which she still holds in reserve, but they are essentially Japanese soil. The men do not shave the hair like the Japanese; they pin it on the crown of the head, with a star in front. The women tattoo their hands. The streets are paved with stone, and stone walls ten or twelve feet high, giving the streets a desolate appearance, enclose the houses, which are similar in structure and arrangements to Japanese houses; the tiles used for roofing, however, are not black, but red in colour. There are no shops in Loochoo, only a market place in each town. The food of the people consists principally of sweet potatoes, pork, and fish, a pig being usually kept by each family. Oshima possesses a good harbour, but Naha, the port of Shima, capital of Okinawa, is an unsafe anchorage. Sugar is largely raised, also the sago palm, and an aromatic variety of orange; the cocoa nut palms do not seem to yield fruit. A small breed of ponies is found on the islands.

Loofah, EGYPTIAN. Under this name the fibrous portion of the fruit of one or two species of *Luffa* (nat. ord. Cucurbitaceæ) is sold in England for use as a bath-sponge or flesh-rubber. There are about ten species of the genus known, but the 'towel gourd,' as this bath-sponge is sometimes called, appears to be obtained chiefly from *L. aegyptiaca*. In the West Indies the fruit of *L. acutangula* yields a similar network of fibres, and it is there used as a sponge or dishcloth. The fibrous portion of these gourds is also worked up into baskets and small ornamental articles.

Looking-glass. See MIRROR.

Lookout Mountain, a ridge extending from near Chattanooga, in Tennessee, across the north-west corner of Georgia, and into Alabama, and rising to 1600 feet above the Tennessee River. It was carried by General Hooker in the battle of 24th November 1863.

Loom. See WEAVING.

Loomis, ELIAS, an American physicist, was born at Willington, Connecticut, 7th August 1811, graduated at Yale in 1830, and was tutor there in 1833-36. After a year's study in Paris he was professor (1837-44) of Mathematics in Western Reserve College, Ohio, of Natural Philosophy (1844-60) in the University of New York, and of Natural Philosophy and Astronomy (from 1860) at Yale. He died 15th August 1889. Professor Loomis devoted much of his time to original research, and was the author of over a hundred scientific treatises, and published a series of text-books on mathematics, natural philosophy, astronomy, and meteorology, of which more than 500,000 copies were sold.

Loon, or LOOM. See DIVER.

Loosestrife. See LYTHRACEÆ.

Lopez de Vega. See VEGA.

Loom. See PARAGUAY.

Lophobranchii. See BONY FISHES.

Loquat (*Eriobotrya Japonica*), an esteemed Chinese and Japanese fruit, of the natural order Rosaceæ, sub-order Roseæ, and of a genus closely allied to *Mespilus* (Medlar). It has been introduced into Australia and is now abundant there. The tree or shrub which produces it attains a height of 20 or 30 feet, but in cultivation is seldom allowed to exceed 12 feet. It is a beautiful ever-green, with large oblong wrinkled leaves, and white flowers in terminal woolly panicles, having a fragrance like that of hawthorn-blossom; the fruit is downy, oval, or pear-shaped, yellow, and about the size of a large gooseberry. The seeds have an agreeable flavour which they impart to tarts. The loquat lives in the open air in the south of England, and produces fruit; but a warmer climate is required for fruit of fine quality. It is hardy about London and southward in England. It may be grafted on any species of *Mespilus*.

Loranthaceæ. See MISTLETOE.

Lorca, a town of Spain, 36 miles SW. of Murcia. The gloomy and decayed Moorish part of the town is picturesquely situated on an eminence crowned by a fortified castle, whilst the modern town spreads out on the fertile plain at its foot. Here are saltpetre, gunpowder, and lead-smelting works, and manufactures of cloth, and in the neighbourhood silver and sulphur mines, &c. Pop. (1884) 28,422.

Lord (A.S. *hlaford*: from *hlaf*, 'loaf,' and, probably, *weard*, 'keeper,' 'master' i.e. master of the house), a title given in Great Britain to persons noble by birth or by creation. Peers of the realm are so styled, including such archbishops or bishops as are members of the House of Lords, who are Lords Spiritual. By courtesy, the title Lord

is given to the eldest sons of dukes, marquises, and earls, prefixed to an inferior title of the peerage, and to the younger sons of dukes and marquises, prefixed to their Christian name and surname (see COURTESY TITLES). The following persons, amongst others, bear the title Lord in virtue of their employments—the Lord-lieutenant of Ireland and Lord-lieutenant of counties, the Lord Chancellor, Lord Privy Seal, Lords of the Treasury and of the Admiralty, the Lord High Admiral, Lord Great Chamberlain and Lord Chamberlain, Lord High Constable, Lord High Almoner, Lord High Steward, Lord Steward of the Household, Lords in Waiting, Lords of the Bedchamber, Lords Justices, the Lord Chief Justice, the Lord Mayors of London, York, and Dublin, and the Lord Provosts of Edinburgh, Glasgow, Aberdeen, and Perth, and the Lord Advocate of Scotland (see special articles on TREASURY, JUSTICE, MAYOR, &c.). The judges of the Courts of Session and Justiciary in Scotland have the title 'Lord' prefixed to their surname or some territorial designation assumed by them; and throughout the three kingdoms judges are addressed as 'My Lord' when presiding in court. See ADDRESS (FORMS OF), NOBILITY, and PARLIAMENT.

Lord Howe Islands, a main island, 5 sq. m. in extent, with some small islets, lying in the Pacific in 31° 33' S. lat. and 159° 5' E. long., 300 miles E. of Port Macquarie in New South Wales. It was discovered by Lieutenant Ball in 1788, colonised in 1840, and is attached administratively to New South Wales. The flora is very rich, baobab-trees being particularly conspicuous. The surrounding waters are full of fish. The island consists of three volcanic ridges, rising to 2840 feet, and is crescentic in shape. Pop. (1859) 300; (1895) 60. A group of the Solomon Islands bears the same name; and a Lord Howe's Island is one of the Society Isles.

Lord-lieutenant OF A COUNTY, a permanent provincial governor appointed by the sovereign by patent under the Great Seal. The office in England arose from the occasional commissions of array issued by the crown in times of danger or disturbance, requiring experienced persons to muster the inhabitants of the counties to which the commissioners were sent, and set them in military order. The right of the crown to issue such commissions was denied by the Long Parliament, this question proving the immediate cause of the breach between Charles I. and his subjects. Their legality was established at the Restoration by a declaratory act. The lord-lieutenant, who is usually a peer or other large land-owner, as a rule is also the *Custos Rotularum* (q.v.). He is at the head of the magistracy, and is the chief executive authority. Under him, and of his appointing, are permanent deputy-lieutenants. He recommends qualified persons for the office of justice of the peace. Militia jurisdiction formerly belonged to him, but is now re-invested in the crown in 1871 (see COUNTY).

Lord-lieutenant OF IRELAND, the viceroy or deputy of the sovereign to whom the government of Ireland is nominally committed. The office has existed from a remote period, the appointment having been made under different designations. The powers of the lord-deputy, as the viceroy was frequently called, were in early times very extensive, almost regal. In the latter part of the 18th century the lord-lieutenant resided little in Ireland, visiting it only once in two years, to hold the session of parliament. Some lords-lieutenant never went to Ireland at all, and occasionally, instead of a viceroy, lords justices (see JUSTICES, LORDS) were appointed. Since the Union the lord-lieutenant has constantly resided in Dublin.

The lord-lieutenant is appointed under the Great

Seal of the United Kingdom, and bears the sword of state as the symbol of his viceregal office. He has the assistance of a privy-council, at present consisting of fifty-five members, appointed by the sovereign, and of officers of state. He is commissioned to keep the peace and the laws and customs of Ireland, and to see that justice is impartially administered. He has the control of the police, and may issue orders to the general commanding the troops for the support of the civil authority, the protection of the public, the defence of the kingdom, and the suppression of insurrection. He is the Grand Master of the Order of St Patrick, and may himself confer simple knighthood; and, previous to the disestablishment of the Church of Ireland, had the disposal of such preferment, as well as all the other patronage of the country. The granting of money, lands, and pensions, of all titles of honour except simple knighthood, the appointment of privy-councillors, judges, law-officers, and governors of forts, and the appointment to military commissions are reserved to the sovereign, acting, however, on the lord-lieutenant's advice and recommendation. In recent years, more especially since his chief-secretary has been a member of the cabinet, the position of the lord-lieutenant has become little more than an 'ornamental' one; and the abolition of the office is now contemplated. A memorial signed by almost all the Irish peers was presented to Lord Salisbury in 1889 praying for such abolition, which had been actually arranged for, as long ago as 1848, by Lord John Russell. Lord Clarendon having accepted office in that year on the understanding that he was to be the last lord-lieutenant of Ireland. On the occasional or temporary absence from Ireland of the lord-lieutenant, lords justices are appointed, who are usually the Lord Chancellor, the Vice-chancellor, and the Commander of the Forces. The salary is £20,000, with a residence in Dublin Castle, as well as one in the Phoenix Park. His tenure of office depends on that of the ministry of which he is a member. By Act 10 Geo. IV. chap. 7, a Roman Catholic is ineligible for the lord-lieutenancy of Ireland. There have been over thirty-five lord-lieutenants since the Union.

Lord of the Isles, a title borne by a race of chiefs who ruled the Western Islands of Scotland with almost regal authority. They were descended from Somerled the Lord of Argyll, on whom David I. having in 1135 expelled the Norwegians from Arran and Bute, conferred these islands. Afterwards, however, he quarrelled with Malcolm IV., and with a powerful force sailed up the Clyde, and, near Renfrew, encountering the royal army under the High Steward of Scotland, was defeated and killed, 1164. His three sons, Dugal, Angus, and Reginald, by his marriage with the daughter of Olaf the Red, the Norwegian king of the Isles, inherited the south isles along with a share of his mainland possessions. One of his grandsons left a daughter and heiress, married to Alexander, son and heir of Walter, High Steward of Scotland, who in her right obtained the isle of Bute. Somerled's sons alternately sided with the Norwegians and the Scots in their contests for the sovereignty of the Western Isles, which repeatedly changed masters. But after the defeat of Haec, his successor in 1266 ceded all the Western Islands to Scotland, on condition that a certain annual sum should be paid to Norway. Henceforward the descendants of Somerled held their possessions as vassals of the Scottish crown. They were represented at this time by three great nobles—the Lord of Lorn, who in the war of independence took part with Comyn and Baliol, Angus of Isla, and Allan of the North Isles, who supported the claims

of Bruce. Angus fought at Bannockburn, and it is said that Bruce, when he was about to bring up the reserve, addressed him in words adopted as a motto by some of his descendants, 'My trust is constant in thee.' John, his son and heir, joined the party of Edward Baliol, but he was ultimately pardoned by David II. and confirmed in his possessions. By his first marriage he obtained the isles of Eist, Barra, Bigg, and Ruin, and assumed henceforth the title of Lord of the Isles. He married, secondly, Margaret, daughter of Robert, High Steward of Scotland (afterwards Robert II.), who bore him three sons. Donald the eldest, second Lord of the Isles, in right of his wife claimed the earldom of Ross in opposition to the Regent Albany, and in attempting to make good that claim he fought in 1411 the celebrated battle of Harlaw. His son Alexander, third Lord of the Isles, was allowed by James I. to inherit the earldom of Ross from his mother; but notwithstanding he took up arms against the king, wasted the crown-lands near Inverness, and burned that town. James promptly attacked and routed the rebels, and their leader was fain to throw himself on the mercy of his sovereign. He presented himself before the king in the church of Holyrood, clothed only in his shirt and drawers, and holding his unsheathed sword by the point, and falling upon his knees, surrendered his sword and implored the royal clemency. His life was spared, but he was imprisoned for two years at Tantallon. During the minority of James II. he held the important office of Justiciar of Scotland north of the Forth. In 1445 he entered into a secret and treasonable league with the Earls of Douglas and Crawford, but died at his castle of Dingwall before any overt acts of rebellion had been committed. His eldest son John succeeded to his titles and estates, and carried on similar insurrectionary proceedings. But after the murder of the Earl of Douglas by James II. he took fright, and entreated the forgiveness of the king, which with some hesitation was granted to him, and he was made one of the wardens of the Marches. After the death of James II., the earl, along with the exiled Douglasses, entered into a treasonable league with Edward IV. of England for the conquest and partition of Scotland, and raised the standard of rebellion. His estates were in consequence forfeited, but on his submission he was restored to the lordship of the Isles; the earldom of Ross was annexed to the crown. In his old age his nephew and heir, apparently with his approbation, at the head of his vassals endeavoured to recover possession of that earldom. James IV., who at this time filled the throne, availed himself of the opportunity to break up that confederacy of the islanders, which had proved so troublesome to the peace of the country; and in the parliament of May 1493 John, fourth and last Lord of the Isles, was forfeited and deprived of title and estates. He retired to the monastery of Paisley, and dying about 1498, was buried beside his ancestor Robert II. In 1540 the Lordship of the Isles was annexed to the Scottish crown, and from it the Prince of Wales derives one of his titles. See A. Mackenzie's *History of the Macdonalds and Lords of the Isles* (Iny. 1882).

Lords-and-Ladies, a popular name for the common Anna q.v.

Lord's Day. See SABBATH.

Lord's Supper, one of the sacraments of the Christian religion, so called from its being instituted at supper by the Lord Jesus Christ. It receives also the names of Eucharist and Communion. With the exception of the Quakers, all sects of Christians, however different their views as to its nature,

agree in celebrating it as one of the most sacred rites of religion. The present article is written from the point of view of those who admit more or less the idea of a historical development of the doctrines connected with the Lord's Supper; the views of Roman Catholics, who hold that the doctrines of their church on the subject were delivered by our Lord and His apostles, and have from the first centuries been taught in substance in the church, will be found under TRANSUBSTANTIATION.

The circumstances of sorrow amid which it was instituted, and its intimate relation to the crowning work of Jesus, His death, had, at the very outset, made a deep impression upon the early church. We have four accounts of the institution, one from each of three evangelists, and one from St Paul (1 Cor. x., xi.); and those who hold the doctrine of the Real Presence see in John vi. an allusion to the Eucharist. Not only was the solemnity, in conformity with the original institution, repeated daily in conjunction with the so-called 'Love feasts' (*Agape*, q.v.), and retained as a separate rite when these feasts were set aside, but at a very early period it was believed to possess a peculiar efficacy, and soon ideas of the wonderful and mystical became associated with it. The Lord's Supper was celebrated on every important occasion of life—as when entering on marriage or to commemorate departed friends and martyrs; to those that could not be present at the meeting of the congregation, such as prisoners and sick persons, the indispensable food of heaven was carried by the deacons, and in some churches the communicants took part of the materials of the feast home with them, that they might welcome the gift of a new day with consecrated food. Heathens and unworthy persons, and Catechumens (q.v.) also, were excluded from this holy mystery. As early as the 2d century, Ignatius, Justin Martyr, and Irenæus advance the opinion that the mere bread and wine become, in the Eucharist, something higher—the earthly, something heavenly without, however, ceasing to be bread and wine. Though these views were opposed by some eminent individual Christian teachers, such as Origen, who took a figurative conception of the sacrament, and depreciated its efficacy, yet both among the people and in the ritual of the church, more particularly after the 4th century, the miraculous or supernatural view of the Lord's Supper gained ground. After the 3d century the office of presenting the bread and wine came to be confined to the ministers or priests. This practice arose from, and in turn strengthened, the notion which was gaining ground, that in this act of presentation by the priest a sacrifice, similar to that once offered up in the death of Christ, though bloodless, was ever anew presented to God. This still deepened the feeling of mysterious significance and importance with which the rite of the Lord's Supper was viewed, and led to that gradually increasing splendour of celebration which under Gregory the Great took the form of the mass. See LITURGY.

For a long time there was no formal declaration of the mind of the church on the presence of Christ in the Eucharist. At length, in the first half of the 9th century, a discussion on the point was raised by the Abbot of Corvey, Paschasius Radbertus, and Ratramnus, a learned monk of the same convent; they exchanged several violent controversial writings, *De Sanguine et Corpore Domini*, and the most distinguished men of the time took part in the discussion. Paschasius maintained that the bread and wine are, in the act of consecration, transformed by the omnipotence of God into that very body of Christ which was once born of Mary, nailed to the cross, and raised from the dead,

According to this conception nothing remains of the bread and wine but the outward form, the taste, and the smell; while Ratramnus would not allow that there is any change in the bread and wine themselves, but granted that an actual transformation of their power and efficacy takes place. The greater accordance of the first view with the credulity of the age, its love of the wonderful and magical, as well as with the natural desire for the utmost possible nearness to Christ, in order to be untailedly saved by Him, and the apparently logical character of the inference that, where the power, according to universal admission, was changed, there must be a change also of the substance—all these concurring influences brought it about that, when the views of Ratramnus were in substance revived by Berengarius, Canon of Tours, in opposition to Lanfranc, Archbishop of Canterbury, and Cardinal Humbert, the doctrine of Transubstantiation, as it came to be called, triumphed, and was officially approved by the Council of Rome in 1079. In the fourth Lateran Council at Rome (1215), under Innocent III., Transubstantiation was declared to be an article of faith; and it has continued to be so held by the Roman Catholic Church to the present day. The Greek Catholic Church sanctioned the same view of Transubstantiation at the Synod of Jerusalem in 1672. For the Calixtines and Taborites, see HESS.

The Reformation of the 16th century again raised the question of the nature of the Eucharist. The Lutheran Church rejected from the first the Catholic doctrine of Transubstantiation, as well as of the mass—i.e. the constant renewal of the sacrifice of Christ—and merely taught that, through the power of God, and in a way not to be explained, the body and blood of Christ are present in, with, and under the unchanged bread and wine ('Consubstantiation'). In opposition to this doctrine, it was laid down by Zwingli that the Lord's Supper is a mere commemoration of the death of Christ, and a profession of belonging to His church, the bread and wine being only symbols; a view which is adopted in substance by Socinians and Arminians. Luther bitterly opposed the symbolical view, especially towards the latter part of his career; Zwingli's doctrine was more repugnant to him than the deeper and more mystic Catholic doctrine.

Calvin sought to strike a middle course, which has been substantially followed by the Reformed Churches. According to him, the body of Christ is not actually present in the bread and wine, which he also holds to be mere symbols. But the 'faithful' receiver is, at the moment of partaking, brought into union with Christ, through the medium of the Holy Spirit, and receives of that heavenly power (efficacy) which is always emanating from His glorified body in heaven. Melancthon, in this controversy, was inclined to the views of Calvin; but he thought a union might be effected by adopting the declaration that Christ in the Eucharist is 'truly and really' present (not merely in faith). The endeavours of Melancthon and his party, by arbitrary alterations of the Augsburg Confession and other means, to effect a public reconciliation only served to rouse among the partisans of Luther a furious theological storm, and the result was the establishment of the views of Luther, and the final separation of the Lutheran and Reformed Churches.

The whole controversy relates to the *mode* in which the body and blood of Christ are present in the Lord's Supper; for it was agreed on all hands that they are present in some way. The Reformed theologians argued that *presence* is a relative term, opposed not to distance, but to absence; and that presence, in this case, does not mean local nearness, but presence in efficacy. Here they parted

company both with the Roman Catholic Church and with the Lutherans. They were willing to call this presence 'real' (if they want words, as Zwingli said), meaning true and efficacious, but they would not admit corporal or essential presence. But while the Reformed Churches were at one in holding that by receiving the body and blood of Christ is meant receiving their virtue and efficacy, there is some difference in their way of expressing what that efficacy is. Some said it was their efficacy as broken and shed i.e. their sacrificial efficacy; others, in addition to this, speak of a mysterious supernatural efficacy flowing from the glorified body of Christ.

With regard to the Reformed Churches, it may be remarked that their Confessions on this point were mostly framed for the express purpose of compromise, to avoid a breach with the Lutherans. Hence the language of these Confessions contains more of the mystical element than the framers of them seem, in other parts of their writings, to favour. And it is remarkable that the Anglican Confessions, which were framed under different circumstances, lean more to the symbolical view of Zwingli than do those of most of the Reformed Churches. The Thirty-nine Articles, after laying down that, 'to such as with faith receive the same, it is a partaking of the body of Christ,' repudiate the notion of Transubstantiation, and add, 'The body of Christ is given, taken, and eaten in the Supper only after an heavenly and spiritual manner. And the mean whereby the body of Christ is received and eaten in the Supper is faith.' The Anglican Church is divided on this, as on several kindred topics, into two parties: with one the symbolical view of the rite is predominant; the other party reprobate this view as 'low,' and maintain an *objective* 'mystical presence' of the thing signified, along with the sign. The view of the latter party as to the sacrificial nature of the Sacrament approaches very closely that of the Church of Rome. For the various points of difference amongst Anglicans as to vestments, the eastward position, &c., reference must be made to the books cited below. In the Mackonochie case (1869) it was decided that the celebrant had no right to kneel during the prayer of consecration; in the Purchase case (1871), that he had no right to adopt the eastward position.

The Presbyterian Church adopted substantially the views of Calvin. The words of the Westminster Confession are: 'That doctrine which maintains a change of the substance of bread and wine into the substance of Christ's body and blood (commonly called Transubstantiation) by consecration of a priest, or by any other way, is repugnant not to Scripture alone, but even to common sense and reason. . . . Worthy receivers, outwardly partaking of the visible elements in this sacrament, do then also inwardly by faith, really and indeed, yet not carnally and corporally, but spiritually, receive and feed upon Christ crucified, and all benefits of His death: the body and blood of Christ being then not corporally or carnally in, with, or under the bread and wine; yet as really, but spiritually, present to the faith of believers in that ordinance as the elements themselves are to their outward senses.' But the tendency is nowa-days to regard the rite in its commemorative character, and the signs as means of working upon the mind and feelings subjectively, rather than as the vehicle of any objective, mystically operating *grace*.

This variety of dogmatical opinion as to the Eucharist naturally gave rise to variety in the ceremonial of its observance. The Catholic notion of a mysterious transformation produced the dread of allowing any of the bread and wine to drop, and

led to the substitution of wafers (*hostia, ablata*) to the breaking of bread. The doctrine of the 'real union,' which declares that in the bread as well as in the wine, in each singly and by itself, Christ entire is present and tasted—a doctrine which was attested by waters visibly bleeding—caused the cup to be gradually withdrawn from the laity and non-officiating priests (see LITURGY); this practice was first authoritatively sanctioned at the Council of Constance, 1415. All the Reformed Churches restored the cup; in the Greek Church it had never been given. From the same feeling of deep reverence for the Eucharist the communion of children gradually came, after the 12th century, to be discontinued; the Greek Church alone admits the practice. Grounded on the doctrine of Transubstantiation, the Greek and Roman Catholic Churches hold the 'elevation of the host' (*hostia, victim* or *sacrifice*) to be a symbol of the exaltation of Christ from the state of humiliation; connected with this is the 'adoration of the host,' and the carrying it about in solemn procession. The use of leavened bread in the Greek Church, and of unleavened in the Roman Catholic and Lutheran, of water mixed with wine in the Roman Catholic and Greek Churches, and of unmixed wine in the Protestant Churches, magnified into importance by symbolical explanations, have given occasion to the hottest controversies. The greater part of the Reformed Churches agree in breaking the bread and letting the communicants take it with the hand (not with the mouth); and this practice is owing to the original tendency of those Churches to the symbolical conception of the Eucharist, in which the breaking of the bread and the pouring out of the wine are essential elements.

It has been contended that the early Christians celebrated the Lord's Supper daily, but a weekly celebration—originally in the evening along with the agapee—is more probable. Abuses at the Agapee (q.v.) led to the separation from them of the Lord's Supper, which now took place in the morning. Early synods ordained that the faithful should receive the communion at all the higher festivals—Epiphany, Easter, Pentecost, Christmas. Early morning communion, received fasting, is the rule with Catholics and High Anglicans, mid-day communion being allowed to aged and invalid persons. The Moravians always celebrate the communion in the evening. In the Roman Catholic Church, it is usual to reserve portions of the Sacrament after celebration for the purpose of permitting the sick to communicate in their own houses. As to kneeling or sitting at communion, see KNEELING. In the English Church it was usual to exclude non-communicants from being present during the rite, as the ancient church excluded catechumens; but neither the modern Catholic Church, the High Anglican, nor the Presbyterian practise this exclusion. In the Highlands of Scotland, through a morbid awe of eating and drinking unworthily, it is customary for devout Christians to postpone communicating till late in life. Of late some teetotalers insist on the use of unfermented wine in the Lord's Supper.

But although the great divisions of the Christian world have continued as churches to adhere to those doctrines about the Lord's Supper which were fixed and stereotyped in Acts of Council and Articles and Confessions about the time of the Reformation, we are not to suppose that the opinions of individuals within those churches continue equally uniform and fixed. Even Roman Catholic theologians, like Bossuet, have sometimes endeavoured to understand the doctrine of the church in a philosophical sense; and in the Lutheran Church the greatest variety of opinion prevails. Some uphold unmodified the dogmas of Luther; others accept them with

explanation; Hegel even undertook to ground them on speculative reason. Others, as Schleiermacher, would have recourse to the views of Calvin as a means of reconciliation with the Reformed Churches. Even all 'supernatural' theologians do not adhere strictly to the formulas of the church; while rationalism in all its phases tends to the pure symbolism of Zwingli.

See the relevant works of Hooker, Barrow, Jeremy Taylor, Waterland, Burnet, Calym, Hodge, Oosterzee, Dörner, Schmid; and Hagenbach's *History of Doctrines*; Wilberforce, *Doctrine of the Holy Eucharist* (1845); Pusey, *Doctrine of the Real Presence* (1855); Scudamore, *Notitia Eucharistica* (1875); J. H. Blunt, *Dictionary of Doctrinal and Historical Theology* (1870); Ebrard, *Das Dogma vom Abendmahl* (1846); Kahnis, *Die Lehre vom Abendmahl* (1851); Ruckert, *Das Abendmahl* (1856); Howson, *Before the Table* (1875); Armstrong, *The Sacraments of the New Testament* (New York, 1880); Dean Stanley, *Christian Institutions* (1881); Bridgett, *History of the Holy Eucharist in Great Britain* (1881); and a *Clerical Symposium on the Lord's Supper*, by Luthardt, Pressense, Littledale, and others (1881).

Lorelei, or **LURLEI** (*lri* = slate-rock), a rock which rises perpendicularly from the Rhine, to the height of 427 feet, near St Goar. It used to be dangerous to boatmen, and has a celebrated echo. But the name is best known from Heine's song of the siren who sits on the rock combing her long tresses, and singing so ravishingly that the boatmen, enchanted by the music of her voice, forget their duty, and are drawn upon the rock and perish. The legend is not, however, 'a *utrochen* of olden days'; the first form of it was an invention of Clemens Brentano, published in his ballad 'Zu Bacharach am Rheine wohnt eine Zauberin' (1800). It soon passed into a popular legend, and has suggested several variants to modern German poets. See Leimbach, *Die Lorelei-Dichtung* (1879).

Lorenzo. See MEDICI.

Loreto, an interior department of Peru, watered for thousands of miles by the Marañon and its tributaries. Area, 33,000 sq. m.; pop. 61,125. The quickest route from the coast to this province, which is only some 700 miles distant in a direct line, is round the north coast of South America and up the Amazons, a journey of 6500 miles. The capital is Iquitos (q.v.).

Loretto (properly LORETO), a city of Italy, stands 3 miles from the Adriatic and 15 by rail SSE. from Ancona. It has a royal palace (designed by Bramante), and 4134 inhabitants; but is chiefly noticeable as the site of the sanctuary of the Blessed Virgin Mary called l. 'Santa Casa, or Holy House, which is reputed to be the house in which the Virgin lived in Nazareth. It was miraculously translated, first, in 1291, to the neighbourhood of Fiume in Dalmatia, thence in 1294 to a wood near Recanati in Italy, and was finally transferred to its present site in 1295. The church of the Santa Casa stands near the centre of the town, before it a colossal bronze statue of Pope Sixtus V. Its great central door is surmounted by a splendid bronze statue of the Madonna; and in the interior are three bronze doors with bas-reliefs, representing the principal events of scriptural and ecclesiastical history. The Holy House itself is a single apartment of no great size, originally of rude material and construction, but now cased with white marble, and exquisitely sculptured, after Bramante's designs, by Sansovino, Bandinelli, and other artists. The subjects of the bas-reliefs are taken from the history of the Virgin Mary, with the exception of three on the eastern side, which are devoted to the legends of the Holy House itself. The image of the Virgin which it contains is traditionally believed to have been carved by

St Luke. The rest of the interior of the church is rich with bas-reliefs, mosaics (by Domenichino and Guido Reni), frescoes, paintings, and carvings in bronze. This shrine is visited by about 50,000 pilgrims annually, though formerly the number averaged 200,000.

L'Orient, a seaport in the French department of Morbihan, situated on a good bay, 116 miles by rail NW. of Nantes, is a well-built town, with a deep and spacious harbour. It was founded in 1664 by the French East India Company; but, after the ruin of their trade by the English towards the close of the next century, their plant was acquired by the government, who since 1815 have made L'Orient the principal naval shipbuilding-yard in France. The dockyard and arsenal are consequently among the best and largest in the country, and the place ranks as a fortress of the second class. L'Orient has schools of navigation and marine artillery, and an observatory. The inhabitants are engaged chiefly in shipbuilding and its cognate trades, and in fishing (especially sardines). The trade does not exceed a total of 100,000 tons annually. Pop. (1872) 30,928; (1891) 41,065. Off this port the British fleet under Lord Bridport defeated the French under Villaret-Joyeuse on 23d June 1795.

Lorimer (Fr. *lormier*, from Lat. *lorum*, 'a thong'), a maker of bits, spurs, stirrup-irons, metal mountings for saddles and bridles, and generally of all articles of horse-furniture. In London the lorimers, who had previously formed part of another guild, were incorporated by letters-patent in 1712; in Scottish burghs they have been comprehended as a branch of the corporation of Hammermen.

Lorimer, JAMES, jurist, was born at Aberdalgie, in Perthshire, on 4th November 1818, studied at Edinburgh, Geneva, Bonn, and Berlin, was called to the Scottish bar in 1845, and in 1862 appointed professor of Public and International Law in the university of Edinburgh. In 1873 he took a principal share in founding the Institute of International Law. He died on 13th February 1890. Besides being a busy contributor to the first edition of this *Encyclopædia* and to the *Edinburgh* and *North British Reviews*, he wrote, from the standpoint of the historic-political school, *Handbook of the Law of Scotland* (1862; 5th ed. 1885); *Constitutionalism of the Future* (1865; 2d ed. 1867); *Reasons for the Study of Jurisprudence as a Science* (1868); *Institutes of Law* (1872; 2d ed. 1880); and *Institutes of the Law of Nations* (1883-84), besides *The Universities of Scotland* (1854); *Political Progress not necessarily Democratic* (1857); and *Studies, National and International* (1891).

Loris, a genus of Lemnidae, with rounded heads and pointed snouts, slender bodies, very large eyes, and rudimentary tail or none at all. The genus has two other names, *Stenops* and *Nycticelus*. The two species known are both natives of the East Indies. The largest species, *L. tardigradus*, is not so large as a cat; the other, *L. gracilis*, is much smaller. They spend the day asleep on a branch, the body rolled up, and the head hidden between the legs. Their fur is rich and soft. Their motions are slow, and they advance stealthily on the insects and birds on which they prey.

Lorne. See ARGYLL and ARGYLL (DUKES OF).

Lorraine was incorporated in the German empire in 855, when Lothair II., son of the Emperor Lothair I., obtained the lands between the Scheldt, Meuse, and Rhine, called Lotharingia, or Lorraine (*Ger. Lothringen*). It at first included Alsace and Friseland; but these provinces were separated from it in 870. About 911 the ruler was elevated from the dignity of count to that of duke. In 954 Lorraine was divided into two

duchies, Upper and Lower Lorraine. The latter came into the hands of the Dukes of Brabant in the beginning of the 13th century, and from that time was known as Brabant. It was incorporated in Burgundy (q.v.) by Philip the Good in 1429, and now forms part of the kingdom of Belgium, and the provinces of Brabant and Guelderland in Holland. Upper Lorraine continued to be governed by its own dukes till 1736, when it was given to Stanislas, ex-king of Poland, and on his death in 1766 was united to France. It was afterwards subdivided into the departments of Meuse, Moselle, Meurthe, and Vosges. The district lying between Metz and the Vosges, which is called German Lorraine, was ceded to Germany at the peace of 1871. See ALSACE-LORRAINE.

Lorraine, CLAUDE. See CLAUDE LORRAINE.

Lory, a common name for the members of a family of parrots, technically known as Trichoglossidae, rigidly confined to the Australian region. They are beautiful, gregarious, noisy, quick-flying birds, feeding on fruits, and gathering the nectar of flowers with their brush-like tongues. The two largest genera are Trichoglossus and Lorius; altogether there are about ninety species. The name lory is also extended to the genus Eclectus, in a different family of parrots.

Los Angeles, the most populous city of southern California and capital of Los Angeles county, is 483 miles S.E. of San Francisco by the Southern Pacific Railroad. It is one of the oldest towns in the western states of America, and was already a thriving place when the Franciscan fathers established a mission here in 1781; its full name being *Pueblo de la Reina de los Angeles*. In 1835-47 it was the capital of the state of California. To-day it possesses a handsome opera-house, the University of southern California, a magnificent observatory, a Roman Catholic cathedral, and over one hundred Protestant churches. There are magnificent botanic gardens, parks, many fine public buildings, and a crematory. The Spanish population is rapidly disappearing, and of the 50,935 inhabitants in 1891 they formed an insignificant minority. The pop. in 1870 was only 5728; in 1880, 11,183. Los Angeles is the centre of the orange-growing industry, and in the city alone are two reservoirs, with a capacity of 850,000 gallons, used solely for purposes of irrigation. The residents are principally occupied in the cultivation and export of oranges, grapes, and other fruits, as well as the manufacture of wine. A great number of invalids and others seeking a fine climate resort to Los Angeles in the winter. See *California of the South*, by Lindley and Widney (1888).

Löss, or LOESS, a loamy deposit of Pleistocene age, abundantly developed in the valleys of the Rhine, the Danube, the Rhone, and many of their tributaries. It is a pulverulent yellowish-gray or brownish loam, homogeneous and non-plastic, and consists principally of clay with small angular grains of quartz, and extremely minute scales of mica, together with a larger or smaller admixture of carbonate of lime and some iron oxide. It has a tendency to cleave in vertical planes, and thus forms cliffs where streams intersect it. The organic remains of the loess consist principally of land-shells of existing species, but now and again fresh-water shells are met with. Occasionally, also, the remains of man and the Pleistocene mammals are encountered, such as mammoth, woolly rhinoceros, reindeer, glutton, &c. In some places again are found relics of lemming, marmot, jerboa, &c., and other forms which are suggestive of steppe conditions. Geologists are still in some doubt as to the origin of the loess. The deposit is of such variable thickness (from a few feet up to 100 yards), and

occurs at such very different levels, that it seems probable that more than one agency was concerned in its formation. Much of the loess was probably deposited from the flood-waters that escaped from the great ice fields and melting snows of glacial times. Some of it again seems to have been the result of the weathering and disintegration of pre-existing accumulations, and the washing down of the disintegrated material by rain. And it seems likely enough that the superficial portions of fluvio-glacial loams may have been modified to some extent by the action of wind. Richthofen, indeed, has maintained that the loess is essentially a wind-blown accumulation—a conclusion he came to from a study of the loess of China (q.v., p. 184). This theory, however, does not explain many of the phenomena, and the general opinion of geologists is in favour of the aqueous origin of loess as a whole. The European loess is undoubtedly associated with the glacial deposits of the Continent, and in North America, where loess is strongly developed, the same relationship obtains. The geologists of the United States Geological Survey maintain that the loessic accumulations which cover enormous areas in the great basin traversed by the Mississippi and its affluents are essentially of fluvial origin.

For a general account of the European loess, see J. Geikie, *Prehistoric Europe* (1881), and *Address to Geol. Section, Brit. Assoc., Newcastle Meeting* (1880). For American loess, see *Sixth Annual Report, U.S. Geol. Survey* (1885). For Chinese loess, see Richthofen's great work on China; also *Geol. Magazine* (p. 293, 1882).

Lost Property. In point of law, the finder of lost property is entitled to keep it until the owner is found; but there are certain circumstances in which the keeping of it will amount to larceny. The rule in England is that, if the finder find the property in such circumstances that he either knows the owner, or has reasonable grounds for believing that he can be found, then the taking of the property with intent to keep it will be larceny. If, for example, a servant finds a sovereign in her master's house, and keeps it, that is larceny; so, too, where the prompter on the stage of a theatre picked up a £50 note which had been dropped by one of the actors. On the other hand, if at the time of finding there be no reasonable probability of ever discovering the true owner, then there is no larceny, even though the finder does afterwards acquire knowledge of or reasonable probability of discovering the true owner. Again, there cannot be a conviction if the finder did not when he took the goods intend to convert them, or if he was under the reasonable impression that the owner had abandoned his right of property therein. It has also been decided that the mere keeping of a lost article, in hopes of getting a reward for giving it up, though the owner be known, does not amount to larceny. There is also no obligation on the finder of lost property to incur expense in advertising for the owner; and it is to be borne in mind that the real owner is not divested of his property by the loss, but can demand it from whosoever is in possession of it. But lost bills of exchange and notes, if transferred for valuable consideration without notice, become the property of the transferee. Moreover, the loser of a bill or note payable to bearer could not at English common law sue the party liable either on the bill or note itself, or on the indorsement, but by sec. 69 of the Bills of Exchange Act, 1882, the court may order that the loss of the instrument shall be no defence to the action if a proper indemnity be given. In Scotland, also, the tenor of a lost bill may be established by a process for proving the tenor. The finder of lost property is not entitled to it, where the property consists of gold, silver, &c., hidden in the earth, in which case the treasure trove belongs

to the crown; and the finder is bound to give notice thereof, under a penalty, though he is not guilty of theft till 'office be found,' or till the coroner's jury have declared it crown property. It is not theft to convert unclaimed wreck.

Lost Tribes. See BABYLONISH CAPTIVITY, ANGLO-ISRAELITE THEORY.

Lot (anc. *Oltis*), one of the largest tributaries of the Garonne in France, rises in Mont Lozere, a section of the Cévennes, flows in a generally western direction, being known at first as the Olt, through the departments of Lozère, Aveyron, Lot, and Lot-et-Garonne, and joins the Garonne from the right at Aiguillon, after a course of nearly 300 miles, nearly two thirds being navigable.

Lot, a department in the south of France, formed out of the old province of Guienne, and comprising the arrondissements of Cahors, Gourdon, and Figeac, is watered by the Dordogne and the Lot. Area, 2012 sq. m.; pop. (1872) 281,404; (1891) 253,885. The eastern districts are invaded by the Causses plateaus of the Cévennes. The valleys are fertile. Wheat, maize, tobacco, fruits, chestnuts, and wine are the more important products. Sheep breeding is largely carried on. Milling, tanning, and the manufacture of woollens are the only branches of industry. Capital, Cahors.

Lot. See DIVINATION, SORTES VIRGILIANÆ.

Lot-et-Garonne, a department in the south-west of France, formed out of the old provinces of Guienne and Gascony. It comprises the arrondissements of Agen, Villeneuve, Marmande, and Nérac, and is watered by the Garonne and its tributaries, the Gers and Lot. Area, 2067 sq. m.; pop. (1841) 347,073; (1891) 295,560. The department is a rolling plain and extremely fertile, except in the south-west, where it is invaded by the Landes (q.v.). The principal products are wheat, maize, wine (20 million gallons annually), hemp, fruits (the plums of Agen are particularly celebrated), tobacco, potatoes, flax, and oil-plants. Pine, cork, and chestnut woods are numerous. Poultry are reared in great numbers for exportation. Manufacturing industry is exhibited chiefly in metal-works, paper-mills, woollen and cork factories, distilleries, and tanneries.

Lothian, the whole territory anciently between the Tweed and the Firth of Forth, which, from 547 a portion of Bernicia or Northumbria, was not finally annexed to Scotland till 1018. The name is now restricted to Haddington, Edinburgh, and Linlithgow shires, which are called respectively East, Mid, and West Lothian. From it the Kers (q.v.) take the titles of Earl and Marquis of Lothian. See SCOTLAND and BORDERS.

Loti, PILEEE. See VIACD.

Lotions, or WASHES, are remedies, usually dilute, of a liquid, but not of an oily nature, which are applied to circumscribed portions of the surface of the body. The only preparations described under this name in the British Pharmacopœia are the yellow and black mercurial lotions, used generally, particularly the latter, in cases of syphilitic origin. Innumerable lotions are used, however, for various conditions and different parts of the body. The most important groups are antiseptic, solutions of corrosive sublimate, carbolic acid, boracic acid, &c.; sedative, containing opium, belladonna, acetate of lead, &c.; stimulating, containing capsicum, sulphur, chloride or sulphate of zinc, &c.

Lotophagi (Gr., 'lotus eaters'), a name applied by the ancients to a peaceful and hospitable people inhabiting a district of Cyrenaica, on the north coast of Africa, and much depending for their subsistence on the fruit of the lotus tree, from which they also made wine. According to Homer, they

received Ulysses hospitably, when, in the course of his wanderings, he visited them along with his companions, on whom, however, the sweetness of the lotus-fruit exercised such an influence that they forgot all about their native country, and had no desire to return home. This feeling of happy languor has been expressed with marvellous felicity by Tennyson in his poem 'The Lotus-eaters.'

Lottery. See GAMBLING.

Lotus. The name *Lotus* (Lat. *Lotus*) was given by the Greeks to a number of different plants whose fruit was used for food. One of the most notable of these is the *Zizyphus Lotus* of the north of Africa and the south of Europe, a shrub belonging



Nymphaea Lotus.

to the natural order Rhamnaceæ (see JELFIRE).—The fruit of the *Diospyros Lotus*, or Date Plum (q.v.), is the European *Lotè*.—The name lotus was also given to several beautiful species of Water-lily (q.v.), especially to the Blue Water-lily (*Nymphaea caerulea*) and the Egyptian Water-lily (*N. lotus*), which grow in stagnant and slowly running water in the south of Asia and north of Africa. The *Nymphaea lotus* grows in the Nile and adjacent rivulets, and has a large white flower. The root is eaten by the people who live near the lake Manzaleh. The rivulets near Damietta abound with this flower, which rises 2 feet above the water. It was the rose of ancient Egypt, the favourite flower of the country, and was often made into wreaths or garlands, placed on the foreheads of women, or held in their hands, and smelt for its fragrance. It frequently appears in the hieroglyphs, where it represents the Upper Country or Southern Egypt, and capitals of columns, prows of boats, and heads of staves were often fashioned in its shape. In mythology it was the emblem of Neter-Tum; Harpocrates is seated upon it; and there was a mystical lotus of the sun. The lotus of Chinese and Hindu mythology is the Nelumbo (q.v.).

Lotto, LORENZO, painter, was born about 1480 in Venice, and died about 1556 in Loretto, where he was latterly supported by the Santa Casa, on which he had bestowed his property. He painted mainly religious and allegorical subjects. See monograph by Berenson (London, 1895).

Lotze, RUDOLF HERMANN, philosopher, was born at Bantzen in Saxony, on 21st May 1817, studied both medicine and philosophy at Leipzig, was appointed professor of the latter subject at the same university in 1842 and at Göttingen in 1844; in 1881 he moved to Berlin, but died on 1st July of that year. It was as a physiologist that he first attracted notice by his articles contributed to Wagner's *Handwörterbuch der Physiologie*. In these he combated the now exploded doctrine of vitalism or a specific 'Lebens-

kraft,' and argued for a thorough-going mechanical treatment of the phenomena of life. The same views were expressed in his *General Physiology of Bodily Life* (1851), and led many to rank him with the materialistic thinkers of the day, though his real philosophical position, to which he remained constant through life, had been already expressed in his *Metaphysik*, published in 1811. The most comprehensive statement of his views on nature and man is contained in his *Microcosmos*, published in 3 vols. in 1856-61 (4th ed. 1885; Eng. trans. 2 vols. 1886). By this book, which he calls 'an attempt at an anthropology,' and in which he invokes the example of Herder, he is most widely known. His attractive style and the semi-popular character of some of its disquisitions have contributed to make it read beyond the schools. A more systematic presentation of his thought on which he was at work towards the close of his life was cut short by death. Only two of the three promised volumes appeared, the first on *Logic* (1874; 2d ed. 1880; Eng. trans. 1884), and the second on *Metaphysics* (1879; 2d ed. 1884; Eng. trans. 1884). In addition to the works named, his *Medicinische Psychologie* (1852) and his *Geschichte der Esthetik in Deutschland* (1868) deserve mention. The paragraphic summaries of his lectures which he was wont to dictate to his students, published in a series of small volumes since his death, afford a useful conspectus of his views. Their publication and translation into English may be taken as a sign of the important influence which Lotze had of late come to exercise upon contemporary thought. Philosophically, Lotze comes of the lineage of Leibnitz and Herbart; he starts, that is to say, from the standpoint of individualism or monadism. But he has also been powerfully influenced by Hegel and the German idealists, and he rounds off his individualism with the doctrine of one infinite real Being, within which individuals act and live. He considers this the only supposition which can explain the action of individual things upon one another. Lotze carries on, however, a constant polemic against what he considers the exclusively intellectual and abstract character of Hegelianism, and his own philosophy may be treated as in great part a justification and reassertion of feeling—in other words, of the demands made by man's ethical, aesthetic, and religious instincts. His other polemic is against the so-called scientific philosophy of the age. While conceding to mechanism its fullest rights in the explanation of events, Lotze everywhere insists that mechanism gives only, as it were, the scaffolding of existence, and that the meaning of the universe can only be read in the light of the Highest Good. Mechanism must be regarded philosophically as the instrument of purpose. Lotze's doctrine is therefore a teleological idealism, largely based on ethical considerations. His distinction, however, is not that of a systematic thinker, and he combats the deductive tendency of his predecessors in German philosophy; his works offer us acute and suggestive reflections on the chief subjects of philosophical interest. See H. Jones, *The Philosophy of Lotze* (1895).

London. GIDEON ERNST, FREIHERR VON, Austrian generalissimo, was born on 2d February 1716, at Tootzen, in Livonia, whither his ancestor had migrated from Ayrshire in the 14th century. In 1732 he entered the Russian service, but ten years later exchanged into that of Austria, soon afterwards marrying and turning Catholic. In the Seven Years' War he won the title of Freiherr (Baron) at Hochkirch (1758); at Kunersdorf (1759) he turned defeat into victory; and his loss of the battle of Lignitz (1760) was due mainly to Lacy and Daun. As field-marshal he commanded in the war of the Bavarian succession (1778), and against

the Turks (1788-89), capturing Belgrade and Semendria. He died at Neutitschein, 14th July 1790. For an admirable estimate of his great military genius, see his *Life* by Colonel Mülleson (Lond. 1884).

London. JOHN CLAUDIUS, a distinguished botanist and horticulturist, born April 8, 1783, at Cambuslang, in Lanarkshire. He became a gardener, and in 1803 published *Observations on Laying out Public Squares*, and in 1805 a *Treatise on Hot-houses*; later he wrote, with an ardour that neither ill-health nor poor circumstances could abate, a long series of books on botany, mostly of a somewhat popular character, which have contributed much to extend a knowledge of that science and a taste for horticulture. Amongst these are the *Encyclopaedia of Gardening* (1822), and of *Agriculture* (1825); the *Greenhouse Companion* (1825); the *Encyclopaedia of Plants* (1829), and the *Arboretum et Fruticetum Britannicum* (8 vols. 1838), containing a very full account of the trees and shrubs, indigenous or introduced, growing in the open air in Britain. This last is his greatest work; but the expense attending the publication, owing chiefly to the number of plates, involved him in pecuniary difficulties. He died at Bayswater, December 14, 1843. London established four different magazines, which he edited simultaneously with his *Arboretum*. In his work he was greatly aided by his accomplished and devoted wife.

Loughborough, a municipal borough, incorporated in 1888, of Leicestershire, 11 miles NNW. of Leicester. The Decorated parish church dates from the 14th century, but has a Perpendicular tower. The grammar-school was founded in 1495, the girls' grammar-school in 1849, and a free library in 1885. Hosiery is the staple manufacture; and bell-founding was introduced in 1840, the great Bell (q.v.) of St Paul's being cast here in 1881. Other industries are dyeing, brick-making, and the manufacture of machinery. There is an active trade in coal. John Howe and Cleveland were natives, and Wedderburn took hence his title Lord Loughborough. Pop. (1851) 10,900; (1891) 18,196. See Dimock-Fletcher's two monographs (1883).

Loughrea, a market-town in County Galway, beautifully situated on a little fresh-water lake, 17 miles SW. of Ballinasloe. It has ruins of a castle and Carmelite monastery, both of about 1300. Pop. 3159.

Louis I. of Bavaria. See BAVARIA.

Louis IX. or ST LOUIS, king of France, born at Poissy, April 25, 1215, succeeded his father, Louis VIII., in 1226. His mother, Blanche of Castile, a woman of great talent and sincere piety, was regent during his minority, and bestowed on him a strictly religious education, which materially influenced his character and policy. When Louis attained his majority he became involved in a war with Henry III. of England, and by his victories compelled the English king to acknowledge French suzerainty in Guienne. During a dangerous illness he made a vow that, if he recovered, he would go in person as a crusader, and accordingly, having appointed his mother regent, he sailed in August 1248, with 40,000 men to Cyprus, whence, in the following spring, he proceeded to Egypt, thinking by the conquest of that country to open the way to Palestine. He took Damietta, but was afterwards defeated and taken prisoner by the Mohammedans. A ransom of 100,000 marks of silver procured his release on May 7, 1250, with the remnant (6000 men) of his army. He proceeded by sea to Acre, and remained in Palestine till the death of his mother (November 1252) compelled his return to France. Having a

large number of blood-relations among the dukes and counts of France, he used these to strengthen the 'legitimist' loyalty to his house, determined by the Pragmatic Sanction the relation of the French Church to the pope, founded the theological college in Paris famous under the name of 'La Sorbonne,' gave France a new judicial organisation by setting up in the provinces royal courts of justice or parliaments, which superseded the jurisdiction of the 'lord of the manor,' and gradually gave rise to the *noblesse de robe*, from amongst which the kings recruited their civil servants. A code of laws was brought into use, known as the *Etablissements de St Louis*. Louis embarked on a new crusade, July 1, 1270, and proceeded to Tunis; but a pestilence breaking out in the French camp carried off the greater part of the army and the king himself. He died August 25, 1270; and his son, Philip III., was glad to make peace and return to France. Pope Boniface VIII. canonised him in 1297. See the *Vie de St Louis* by Joinville (q.v.), Louis's friend, and Wallon's Life of him (2d ed. Paris, 1878).

Louis XI., king of France, the eldest son of Charles VII., born at Bourges, July 3, 1423, was from his boyhood eminently cruel, tyrannical, and perfidious. He made unsuccessful attempts against his father's throne, was compelled to flee to Brabant, and sought the protection of Philip the Good, Duke of Burgundy, with whom he remained till his father's death in 1461, when he succeeded to the crown. The severe measures which he immediately adopted against the great vassals led to a coalition against him, at the head of which were the great Houses of Burgundy and Brittany. Louis owed his success more to his artful policy than to arms; and, the war threatening to break out anew, he invited Charles the Bold, Duke of Burgundy, to a friendly conference at Péronne in October 1468. His agents meanwhile had stirred up the people of Liège to revolt against the duke, in return for which deed Charles made him a prisoner, and compelled him to associate in the punishment of Liège. Full of resentment, Louis then stirred up against Charles the Flemish towns and the Swiss republics. It became from that time a practice with French kings to have Swiss mercenaries in their pay. The Swiss defeated Charles twice, and killed him in a last battle (1477). Louis then claimed Burgundy as a vacant French fief, but was prevented from gaining possession of Charles's Flemish lands by the marriage of Mary, the rightful heir, to Maximilian of Austria. The troops of the latter defeated the French at Guinegate (1479), but the war was renewed on the death of Mary. A peace was concluded at Arras, December 25, 1482, by which the counties of Burgundy and Artois were handed over to France. Louis was also successful—after the use of means far from honourable—in annexing Provence to the crown as a lapsed fief. In order to weaken his feudal vassals he greatly increased the power and number of parliaments, an institution agreeable to the towns and to the middle class, and to which he began to grant a voice in matters of state. His favourite residence was the chateau of Plessis-les-Tours, close to Tours. His chief advisers and favourites were Olivier le Dain, originally a barber, but made a count; Tristan l'Hermite, and Cardinal Baluc. He spent the latter years of his reign in great misery, in excessive horror of death, which superstitions and ascetic practices failed to allay. He died at Plessis-les-Tours, August 30, 1483. He is said to have been the author of *Les veul Nouvelles nouvelles*, a sort of imitation of the *Decameron*, and of the *Rosier des Guercis*, a book of instruction for his son. He founded three universities.

See the contemporary *Mémoires* of Philippe de Comines (q.v.); works by Legeay (1874), Willert (in English, 1876), Buet (2d ed. 1886), and Vaesen and Charavay (1885 *et seq.*); and Scott's *Quentin Durward*. The well-known play *Louis XI.* is by Delavigne.

Louis XIII., king of France, son of Henry IV. and Marie de' Medici, born at Fontainebleau, 27th September 1601, succeeded to the throne on the assassination of his father, 14th May 1610, his mother being called to the regency by an edict of the parliament of Paris, which had acquired a right to speak in the name of all the others. She entered into close alliance with Spain and the pope, and betrothed the king to Anne of Austria, daughter of Philip III. of Spain, upon which the Huguenots took up arms; but peace was concluded at St Menchould on 5th May 1614. The king, who was now declared of age, confirmed the Edict of Nantes, and in the same year the French *États Généraux*—consisting of members of the clergy, the nobility, and the middle classes, a body more ancient than the parliaments, and in which the *bourgeoisie* sided with the kings—were summoned for the last time, as the events proved, till the reign of Louis XVI., for this constitutional chamber showed itself powerless to agree upon and follow out a policy. The restoration of Catholic church-rights in Bearn led to the religious war, in which the Protestants lost almost all their places of security, and which ended in 1622. After the death of De Luynes, in 1624, Richelieu, afterwards Cardinal and Duke, became the chief minister of Louis. His powerful mind obtained complete control over that of the weak king, and his policy effected that increase of monarchical power, at the expense of Protestants, nobles, and parliaments, which reached its consummation in the reign of Louis XIV. The overthrow of the Huguenots was completed by the capture of Rochelle, 20th October 1628, at the siege of which the king took part in person. Richelieu now led Louis to take part in the Thirty Years' War, openly supporting Gustavus Adolphus and the Dutch against the Spaniards and Austrians. The latter years of Louis's reign were signalised by the getting possession of Alsace and of Roussillon, acquisitions which were confirmed in the following reign. Louis died 14th May 1643. Under his reign was prepared the period of French ascendancy in Europe. His queen, after twenty-three years of married life, bore a son in 1638, who succeeded to the throne as Louis XIV.; and in 1640 a second son, Philip, Duke of Orleans, the ancestor of the present House of Orleans.

See MARIE DE' MEDICI, RICHELIEU; and French works by Bazin (new ed. 4 vols. 1846), Topin (1876), and Zeller (1879).

Louis XIV., king of France, born at St Germain-en-Laye, 16th September 1638, succeeded his father, Louis XIII., in 1643. His mother, Anne of Austria, became regent, and Mazarin (q.v.) her minister. During the king's minority the discontented nobles, encouraged by Spain, sought to shake off the authority of the crown, and the civil wars of the *Fronde* (q.v.) arose. Peace was concluded in 1659; and in the following year Louis married the Infanta Maria Theresa, a princess possessing neither beauty nor other attractive qualities. Little was expected from the young king; his education had been neglected, and his conduct was dissolute; but on Mazarin's death in 1661 he suddenly assumed the reins of government, and from that time forth carried into effect with rare energy a political theory of pure despotism. His famous saying, 'L'état c'est moi' ('I am the state'), expressed the principle to which everything was accommodated. He had a cool and clear head, with much dignity and amenity of manners,

great activity, and indomitable perseverance. The distress caused by the religious wars had created throughout France a longing for repose, which was favourable to his assumption of absolute power. He was ably supported by his ministers. Manufactures began to flourish under the royal protection. The fine cloths of Louviers, Abbeville, and Sedan, the tapestries of the Gobelins, the carpets of La Savonnerie, and the silks of Tours and Lyons acquired a wide celebrity. The wonderful talents of Colbert (q.v.) restored prosperity to the mined finances of the country, and provided the means for war; whilst Louvois (q.v.) applied these means in raising and sending to the field armies more thoroughly equipped and disciplined than any others of that age.

On the death of Philip IV. of Spain Louis, as his son-in-law, set up a claim to part of the Spanish Netherlands; and in 1667, accompanied by Turenne (q.v.), he crossed the frontier with a powerful army, took many places, and made himself master of that part of Flanders since known as French Flanders, and of the whole of Franche Comté. The *triple alliance*—between England, the States-general of Holland, and Sweden—arrested his career of conquest. The treaty of Aix-la-Chapelle (1668) forced him to surrender Franche Comté. He vowed revenge against the States-general, strengthened himself by German alliances, and purchased with money the friendship of Charles II. of England. He seized Lorraine in 1670; and in May 1672 again entered the Netherlands with Condé and Turenne, conquered half the country in six weeks, and left the Duke of Luxembourg to lay it waste. The States-general formed an alliance with Spain and with the emperor, but Louis made himself master of ten cities of the empire in Alsace, and in the spring of 1674 took the field with three great armies, of which he commanded one in person, Condé another, and Turenne a third. Victory attended his arms; and, notwithstanding the death of Turenne and the retirement of the Prince of Condé from active service, he continued in subsequent years, along with his brother, the Duke of Orleans, to extend his conquests in the Netherlands, where, by his orders, and according to the ruthless policy of Louvois, the country was fearfully desolated. The peace of Nimeguen in 1678 left him in possession of fortresses in the Spanish Netherlands and of Franche Comté. He now established *Chambres de Revision* in Metz, Breisach, and Besancon, packed courts of law, in which his own will was supreme, and which confiscated to him, as feudal superior in right of his conquests, territories which he wished to acquire, seignories belonging to the Elector Palatine, the Elector of Trèves, and others. He also, on 30th September 1681, made a sudden and successful attack on Strasburg, a free German city, the possession and fortification of which added greatly to his power on the Rhine. The acquisition thus made a treaty in 1684 confirmed to him.

Louis had now reached the zenith of his career. All Europe feared him; his own nation had been brought by tyranny, skilful management, and military glory to regard him with Asiatic humility, admiring and obeying; all remnants of political independence had been swept away; no Assemblies of the States or of the Notables were held; the nobles had lost both the desire and the ability to assert political power; the municipal corporations no longer exercised any right of election, but received appointments of officials from the court; the provinces were governed by *intendants*, who were immediately responsible to the ministers, and they to the king, who was his own prime-minister. Even the courts of justice yielded to the absolute sway of the monarch, who interfered at pleasure

with the ordinary course of law, by the appointment of commissions, or withdrew offenders from the jurisdiction of the courts by *Lettres de Cachet* (q.v.), of which he issued about 9000 in the course of his reign. He asserted a right to dispose at his pleasure of all properties within the boundaries of his realm, and took credit to himself for gracious moderation in exercising it sparingly. The court was the very heart of the political and national life of France, and there the utmost splendour was maintained; and a system of etiquette was established which was a sort of perpetual worship of the king.

It was a serious thing for France and the world when Louis fell under the control of his mistress, Madame de Maintenon (q.v.), whom he married in a half-private manner in 1685, and who was herself governed by the Jesuits. One of the first effects of this change was the adoption of severe measures against the Protestants. When it was falsely reported to Louis that his troops had dragooned all heretics into conversion, he revoked the Edict of Nantes in 1685, and then ensued a bloody persecution; whilst more than half a million of the best and most industrious of the inhabitants of France fled, carrying their skill and industry to other lands. Yet Louis was by no means willing to yield too much power to the pope; and, quarrelling with him concerning the revenues of vacant bishoprics, he convened a council of French clergy, which declared the papal power to extend only to matters of faith, and even in these to be dependent upon the decrees of councils.

The Elector of the Palatinate having died in May 1685, and left his sister, the Duchess of Orleans, heiress of his movable property, Louis claimed for her also all the allodial lands; and from this and other causes arose a new European war. A French army invaded the Palatinate, Baden, Würtemberg, and Trèves in 1688. In 1689 the Lower Palatinate and neighbouring regions were laid waste by fire and sword. This atrocious proceeding led to a new coalition against France. Success for a time attended the French arms, particularly in Savoy and at the battle of Steinkerk. Reverses, however, ensued; the war was waged for years on a great scale, and with various success; and after the French, under Luxembourg, had gained, in 1693, the battle of Neerwinden, it was found that the means of waging war were very much exhausted, and Louis concluded the peace of Ryswick on 20th September 1697. The navy destroyed, the finances grievously embarrassed, the people suffering from want of food, and discontent becoming deep and general, Louis placed the Count D'Argenson at the head of the police, and established an unparalleled system of espionage for the maintenance of his own despotism. The power of Madame de Maintenon and her clerical advisers became more and more absolute at the court, where scandals of every kind increased.

When the death of Charles II. of Spain took place, on 1st November 1700, it was found that Louis had obtained his signature to a will by which he left all his dominions to one of the grandsons of his sister, who had been Louis's queen. Louis supported to the utmost the claim of his grandson (Philip V.), whilst the Emperor Leopold supported that of his son, afterwards the Emperor Charles VI. But the power of France was now weakened, and the war had to be maintained both on the side of the Netherlands and of Italy. One bloody defeat followed another; Marlborough was victorious in the Low Countries, and Prince Eugene in Italy; whilst the forces of Louis were divided and weakened by the employment of large bodies of troops against the Camisards in the Cévennes, for the extinction of the last relics of Protestantism.

On the 11th April 1713 peace was concluded at Utrecht, the French prince obtaining the Spanish throne, but France sacrificing valuable colonies. A terrible fermentation now prevailed in France, and the country was almost completely ruined; but the monarch maintained to the last an unbending despotism. He died, after a short illness, 1st September 1715. He was succeeded by his great-grandson, Louis XV. His son, the dauphin, and his eldest grandson, the Duke of Brittany, had both died in 1711. Louis had a number of natural children, and he had legitimised those of whom Madame de Montespan was the mother; but the Paris parliament, which made no objection to recording the edict when required by him, made as little objection to annulling it when required by the next government. The 'works' of Louis XIV. (6 vols. Paris, 1806), containing his Instructions for his sons, and many letters, afford important information as to his character and the history of his reign. The reign of Louis XIV. is regarded as the Augustan age of French literature and art, and it can hardly be doubted that France has never since produced poets like Corneille and Racine in tragedy, or Moliere in comedy, satirists like Boileau, or church orators and divines like Bossuet, Fenelon, Bourdaloue, and Massillon.

See Voltaire's *Siècle de Louis XIV.* (1740), the *Mémoires* of Saint-Simon (1788; in English, abridged, 1876); and other works by Gaillardin (6 vols. 1871-76), Cosnac (8 vols. 1874-81), Chérel (4 vols. 1878-80), Michelet (3d ed. 1875), Michand (1882-83), Chotard (1890), Du Cause de Nazell (1899), Pardoe (1886), Hassall (1895); for 'le style Louis Quatorze' in art. Genevay (1887).

LOUIS XV., king of France, the great-grandson of Louis XIV., born at Versailles, 15th February 1710, succeeded to the throne 1st September 1715. The Duke of Orleans, as first prince of the blood, was regent during the minority of the king, whose education was entrusted to Marshal Villeroi and Cardinal Fleury. The regent and the country became incomprehensibly infatuated with the financial schemes of the Scotsman Law (q.v.). All available capital was drawn away from agriculture and trade, pocketed by the financial cliques, the court, and the state, whose debt was thereby substantially reduced, and worthless paper-money issued instead. Every kind of indulgence in luxury and vice accompanied in high places this financial insanity. When Louis was fifteen years of age he married Maria Leszcynski, daughter of Stanislas, the dethroned king of Poland. At the death of the regent and of his shameless prime-minister Cardinal Dubois, Louis reigned personally, and put at the head of affairs his old, wise, and prudent teacher Cardinal Fleury, who repaired somewhat the economic disasters of his predecessors, and set his face against a warlike policy.

Louis having become involved in the war of the Polish Succession through his father-in-law, the duchy of Lorraine was without much fighting obtained for the latter, and for the French crown after him. When the war of the Austrian succession broke out (1740) Cardinal Fleury was averse to burdening the state with fresh debt and new military charges in support of the claims of the prince-elector of Bavaria to the imperial crown. Louis was then falling under the influence of a number of voluptuous and immoral noblemen, who set up a barrier between him and his wife, and delivered him into the hands of vice. Fleury lost ground; the government became a toy for ambitious courtiers and dissolute women, in the satisfaction of whose vanity war was declared against Austria. After a course of easy conquest in 1741 the French were badly beaten in 1742; regret and worry brought Fleury to the grave in the next year. But in the following years France, in alli-

ance with Frederick the Great of Prussia, was repeatedly victorious on land, at Fontenoy (1745), for instance, where Louis delighted his latest mistress with the flight of English, Dutch, and Austrian troops, though on the sea the English put an end to the French navy and sea-faring trade. When peace was signed at Aix-la-Chapelle France had nothing to show save the ruinous disorganisation of her finances.

The king now sank completely under the control of Madame de Pompadour, who was both concubine and procuress, and to whom he gave notes on the treasury for enormous sums, amounting in all to hundreds of millions of livres. War broke out again with Britain concerning the boundaries of Acadia (Nova Scotia), and was for some time prosecuted with considerable vigour. In 1756 an extraordinary alliance was formed between France and Austria, contrary to the policy of ages, and chiefly through the influence of Madame de Pompadour. Directed against Prussia as a threatening Protestant power, this alliance had no other result than Frederick the Great's complete victory over the French at Rossbach. The state of the finances, the dispirited condition of the army, and the outcry of the distressed people were not sufficient to induce the king to make peace; but, governed by his mistress, he obstinately persevered in war, even after the terrible defeat of Minden in 1759; whilst the British conquered almost all the French colonies both in the East and West Indies, with Cape Breton and Canada. A peace most humiliating to France was at last concluded in 1763.

Louis, although indifferent to the ruin of his people, and to everything but his own vile pleasures, was reluctantly compelled to take part in the contest between the Paris parliament and the Jesuits (q.v.), the result of which was the suppression of the order in 1764. The parliament, emboldened by success in this contest, now attempted to limit the power of the crown by refusing to register edicts of taxation; but the king maintained his own absolute and supreme authority, thanks to the indifference with which the people and the middle class viewed the privileges of the *noblesse de robe*. The Duc de Choiseul was now displaced from office, a new mistress, Madame du Barry, having come into the place of Madame de Pompadour; and a ministry was formed under the Duke d'Aiguillon, every member of which was an enemy of the parliaments and abjectly immoral. The councillors of the parliament of Paris were removed from their offices, and banished with great indignity; an interim parliament was appointed (January 1771), which duly obeyed the court. The princes of the blood protested against this arbitrary act, which left them without any means of appeal against the royal will. The king, when told of the ruin of the country and the misery and discontent of the people, only remarked that the monarchy would last as long as his life, and continued his course of sensual pleasures and trifling amusements. He boasted of being the best cook in France, and was much gratified when the courtiers ate eagerly of the dishes which he had prepared. His gifts to Madame du Barry, notwithstanding the embarrassment of the finances, in five years amounted to 180 millions of livres. At last Louis, whose constitution was already shattered from the effects of a life of vice, was seized with smallpox, and on 10th May 1774 he died in abject misery, so far from being regretted that his funeral was a sort of popular festival, and was celebrated with pasquils and merry ballads. Such was the end of Louis 'le Bien aimé.'

See Voltaire's *Siècle de Louis XV.* (2 vols. 1768-70), and other works by Tocqueville (2d ed. 1847), Bonhomme

(1873), the Duke de Broglie (Eng. trans. 1879), Vandal (1882), Perkins (1897), and Waddington (1897).

Louis XVI., king of France, born 23d August 1754, was the third son of the dauphin, Louis, only son of Louis XV. He was styled Duc de Berry until, by the death of his father and his elder brothers, he became dauphin. He had a vigorous frame, was fond of hunting and manly exercises, took great pleasure in making locks and such mechanical labours, and showed an aptitude for geometry but none for political science. In the midst of the most corrupt of courts he grew up temperate, honest, and moral. He was married on 10th May 1770 to Marie Antoinette, the youngest daughter of the Empress Maria Theresa.

When Louis ascended the throne the public treasury was empty, the state burdened with a debt of 4000 millions of livres, all borrowing credit was exhausted, the people were crushed under the weight of taxes, and all respect had gone from king, court, church, and governing classes. Personally full of good-will, he failed to restrain the excesses of his brothers and to resist the influence of his proud and high-handed consort. He yielded unwisely to the advice of his first prime-minister, Maupeau, an incompetent and narrow-minded courtier, in restoring to the Paris and provincial parliaments their semi-political rights in the matter of public expenditure and local taxation. The accession of Malesherbes and Turgot to the ministry heralded thorough-going reforms, which Voltaire hailed as the 'dawn of the age of reason' in French politics. But these proposals, accepted by the king, were rejected by the court, the aristocracy, the parliaments, and the church. Turgot resigned his office. Yet Louis succeeded in the remission of some of the most odious taxes, the abolition of the last relics of serfdom, the abolition of torture in judicial investigations, a reduction of the expenditure of the court, and the foundation of institutions for the benefit of the working-classes. He was for a time extremely popular, though deeper reforms were rendered impossible by the opposition of the privileged classes and the obstinacy of the queen. In June 1777, when the state of the finances seemed nearly desperate, Necker was made Director-general, and succeeded in bringing them to a more tolerable condition, without any very radical change; but, from the interference of France in the American war of independence, he was obliged to propose the taxation of the privileged classes hitherto exempted. Their resistance compelled him to resign. The American war swallowed up the revenue of three years. The appointment in 1783 of Calonne (q.v.), a spendthrift, to the finances renewed for a while the splendour of the court. At his wits' end, he advised the calling together of an Assembly of Notables, such as the monarchy, especially under Richelieu's premiership, had occasionally summoned to its help. The noblemen, clergymen, state-officials, councillors of parliaments, and municipal officers thus collected showed him bitter hostility, and, when he revived Necker's proposals, compelled him to fly to London. His successor, Loménie de Brienne, obtained some concessions and some new taxes. But the parliament of Paris refused to register the edict of taxation, as oppressive to the people; for the extravagance of the court and the queen began to be freely spoken of in a nation now fully acquainted with the facts. The convening of the States-general was demanded from every corner of France. The king registered the edicts in a *Lettre de justice*, and banished the councillors of parliament to Troyes, but ere long found it necessary to recall them, and experienced from them even a stronger opposition than before. On 8th May 1788 he dissolved all the parliaments and established a new kind of court

(*Cour Phœnix*) instead; but this act of despotism set the whole country in flames. Matters became still worse when on 16th August appeared the famous edict, that the treasury should cease from all cash payments except to the troops. Brienne was compelled to resign, and Necker again became minister. An Assembly of the States of the kingdom, in abeyance since 1614, was resolved upon; and by the advice of Necker, who wished a counterpoise to the influence of the nobility, clergy, and court, the Third Estate was called in double number, while in other respects the precedent set in 1614 was adhered to.

The subsequent history of Louis is given under the head FRANCE. All readers of history are familiar with the melancholy incidents of his life, from the opening of the Assembly of the States (5th May 1789) down to his tragic execution. At ten o'clock in the morning of the 21st of January 1793 he died by the guillotine, in the Place de la Revolution. Great precautions were taken to prevent any rescue. As the executioner bound him Louis tore himself free and exclaimed: 'Frenchemen, I die innocent; I pray that my blood come not upon France.' The rolling of drums drowned his voice.

The share of the French in the American war of independence is a bright and almost romantic episode in the drama of this reign. Franklin kindled in excitable Paris such enthusiasm for liberty and democracy that the Marquis de Lafayette and some other ideal-loving gentlemen crossed the sea in defence of England's colonies. A formal alliance ensued, and assistance was given in men, money, and ships.

See MARIE ANTOINETTE, NECKER, TUEGOT, MIRABEAU; and works by Soulaye (1801), Bourmisseaux (1829), Droz (2d ed. 1858), Capefigue (1844), Tocqueville (2d ed. 1830), and Jobez (3 vols. 1877-93).

Louis XVII., CHARLES, second son of Louis XVI. of France, born at Versailles, 27th March 1785, received the title of Duke of Normandy, till, on the death of his brother in 1789, he became dauphin. He was a promising boy. In the earlier days of the Revolution he was sometimes dressed in the uniform of the National Guard and decorated with the tricolor to gratify the populace. After the death of his father he continued in prison—at first with his mother, but afterwards apart from her—in the Temple, under the charge of a brutal Jacobin shoemaker named Simon, who treated him with great cruelty and pushed him into vicious excesses, so that he became a mere wreck both in mind and body. After the overthrow of the Terrorists he was, perhaps intentionally, forgotten, and died 8th June 1795. A report spread that he was poisoned, but a commission of physicians examined the body and declared the report unfounded.

All the attempts made by Louis XVIII. in 1815 to find the remains of this most hapless victim of the Revolution proved fruitless, and this fact gave room for the appearance of a succession of false dauphins, whose claims deluded many honest royalists in France. Of these the first was Jean Marie Hervagault, the son of a St. Lo tailor, born in 1781, who ran away from home at fourteen, and soon found many supporters in Brittany, Normandy, Champagne, and Burgundy. In 1802 he was sentenced for his imposture to a four years' imprisonment, and later, under Napoleon's empire, was confined in the Bicêtre, where he died in 1812. Another false Louis, who attracted some attention under the name Charles of France, was Mathurin Bruneau, born in 1784 at Bezins, the son of a maker of wooden shoes. He early took to a roving life, was committed as a vagrant in 1803, next spent some years in North America, returned to push his claims in France, and was sent to prison

for seven years at Ronen. After the July revolution he disappeared. The third false Louis XVII., who attracted much attention in 1833 and 1834, was the so-called Duc de Richmont, whose proper name was François Henri Hébert, a native of the Rouen district. The idea that he was a son of Louis XVI. first possessed him about 1828. After the July revolution he protested in a series of writings against Louis-Philippe, and attempted to push his claim by *Mémoires*. In 1834 he was sent to jail for twelve years, but eight months later succeeded in making an escape to London, where he died in 1845. Perhaps the most remarkable claimant was the Potsdam watchmaker, Karl Wilhelm Naundorf, whose claim rested on a striking Bourbon resemblance. After many crosses in Berlin, Spandau, and Brandenburg, besides a three years' imprisonment, he found his way to France in 1833, but was expelled three years later. He made his way to England, and died in 1845. His children assumed the name of Bourbon, and in 1851 and 1874 raised fruitless actions before the Paris law-courts against the Comte de Chambord. See Elizabeth Evans's *Story of Louis XVII.* (1893).

LOUIS XVIII., STANISLAS XAVIER, the next younger brother of Louis XVI., born at Versailles, 17th November 1755, received the title of Comte de Provence. In 1771 he married Maria Josephine Louisa, daughter of Victor Amadeus III. of Sardinia. After the accession of Louis XVI. to the throne he assumed the designation of *Monsieur*, and became an opponent of every salutary measure of the government. He fled from Paris on the same night as the king, and was more fortunate, for, taking the road by Lille, he reached the Belgian frontier in safety. With his brother, the Comte d'Artois, he now issued declarations against the revolutionary cause in France, which had a very unfavourable effect on the situation of the king. The two brothers for some time held a sort of court at Coblenz. Louis joined the body of 6000 émigrés who accompanied the Prussians across the Rhine in July 1792, and issued a manifesto even more foolish and extravagant than that of the Duke of Brunswick. After the death of his brother, Louis XVI., he proclaimed the latter's son king of France, as Louis XVII., and in 1795 himself assumed the title of king. The victories of the republic and Napoleon's enmity to the Bourbon family compelled him frequently to change his place of abode, removing from one country of Europe to another, till at last, in 1807, he found a refuge in England, and purchased a residence, Hartwell, in Buckinghamshire, where his wife died in 1810, and where he remained till the fall of Napoleon opened the way for him to the French throne. On 26th April 1814 'le Desiré,' as the royalists style him, landed at Calais, after twenty-four years' exile. His return, under the protection of the allied armies, had been prepared for by Talleyrand. Then began the ascendancy of the legitimist party. The powerless empress regent was superseded by a provisional government, the Napoleonic constitution was set aside, and, in keeping with the doctrine of the 'divine right of kings,' all power was claimed by Louis XVIII. Using his discretionary rights, he granted to the nation a constitutional charter, establishing a House of Peers and a Chamber of Deputies, and vouchsafing a few elementary citizen rights, but in every essential respect he resumed the baneful traditions of the ancient monarchy. See FRANCE.

The nobles and priests exercised an influence over the weak king which led to severe treatment of the Imperialists, the Republicans, and the Protestants. This opened the way for Napoleon's return from Elba, when the king and his family fled from Paris, remained at Ghent till after the battle of

Waterloo, and returned to France under the protection of the Duke of Wellington. He issued from Cambrai a proclamation in which he acknowledged his former errors, and promised a general amnesty to all except traitors. But the Chamber of Deputies, cleft with many irregularities, was so fanatically royalist and reactionary that the king, by advice of the Emperor Alexander of Russia, dissolved it; whereupon arose royalist plots for his dethronement and the abolition of the charter. Bands of assassins were collected by nobles and priests in the provinces, who slew hundreds of adherents of the Revolution and of Protestants, and years elapsed ere peace and good order were in any measure restored. Driven by royalistic fanatics, the king dismissed his too moderate prime-minister Decazes, and could not prevent an army from passing into Spain to maintain there the right of absolute kingship. He died 16th September 1824. See Petit's *Louis XVIII.* (1885).

LOUISA, queen of Prussia, was born 10th March 1776, at Hanover, where her father, Duke Karl of Mecklenburg-Strelitz, was then commandant. She was married to the Crown-prince of Prussia, afterwards Frederick-William III., on 24th December 1793, and was the mother of Frederick-William IV. and William III., afterwards emperor. After her husband's accession to the throne she became exceedingly popular, her great beauty being united with dignity and grace of manners, and with much gentleness of character and active benevolence. This popularity was increased by her conduct during the period of national calamity that followed the battle of Jena, when she displayed not only a patriotic spirit, but no little energy and resolution. She especially endeared herself to her people by her bearing when compelled to endure insult at the hands of Napoleon. She died in Strelitz, 19th July 1810. The Prussian Order of Louisa, the Louisa School for girls, and the Louisa Governesses' Seminary were instituted in her honour. There is a beautiful monument and portrait-statue of her by Rauch in the mausoleum at Charlottenburg. See her *Life and Times*, by E. H. Hudson (1877), and German works by Horn (1883) and Martin (1887).

LOUISBURG, a port on the south-east coast of Cape Breton Island, Nova Scotia, 27 miles S.E. of Sydney. It is now inhabited only by a few fishermen; but there are the ruins of the old town, which under the French had a large export trade in coal, and was the strongest fortress in North America, until taken by the English in 1758. It had already been captured by the New England colonists and an English squadron in 1745, and restored in 1748; now its fortifications, which had been thirty years in building and cost over a million sterling, were demolished, and it gradually sank into ruin.

LOUIS-D'OR (i.e. 'Golden Louis'), a gold coin which was introduced into France in 1641, and continued to be coined till 1795. The louis-d'or ranged in value from about 16s. 7d. to 18s. 9½d. sterling.—In some parts of Germany, in the old coinage, were gold pieces of five thalers, often popularly called *louis-d'or*, and the name has been occasionally applied to the French *napoleon* or *20-franc piece*.

LOUISIADÉ ARCHIPELAGO, a group of islands belonging to British New Guinea, and forming an eastward extension of that island. It embraces Sudest (45 miles long by 4 to 10 miles wide), Rossel, St Aignan's (28 miles long by 8 to 9 miles wide), and a vast number of smaller islands. All are mountainous, rising to 3500 in St Aignan's, and covered with vegetation. The inhabitants are

numerous, but wild, and head-hunters; they seem to partake of both Malayan and Papuan characteristics.

Louisiana, one of the Gulf states of the American Union, extends about 200 miles from north to south and 200 from east to west. Its land area, including the marshes bordering on the Gulf, is 40,790 sq. m.; its inland waters cover 2328 sq. m.; total area, 43,118 sq. m. This area is divided nearly equally between alluvial lands and uplands. The mean elevation of the state above sea-level is 75 feet, its highest point 484 feet. For 25 miles inland from the Gulf, marshes subject to tidal flow cover one-eighth of the state's entire surface; low, sandy pine flats and prairie lands occupy about one-eighteenth each, arable lands one-eighth, the flood-plains near the rivers one-tenth, and bluff lands, pine hills, and uplands more than one-fifth each. Most of the large rivers flow above the level of the surrounding country on ridges formed by their own deposits, and the plains around, protected by dykes (called levees), slope away into dense, wooded swamps. The bottom-lands of the Mississippi are from 20 to 70 miles in breadth, those of the Red, Ouachita, and other streams range from 6 to 20 miles. But although the flood-plains lie below, there is a large area above the rivers' high-water mark. The uplands embrace all the northern and north-eastern parts of the state, inclining gently towards the south, and crossing these are bluff lands, extending through the alluvial lands to the Gulf, and forming wonderful 'islands' covered with vegetation. Nor is the immense plain surrounding these bluffs ever inundated, but elevated and fertile, traversed by deep bayous (as minor and tributary streams are called here). Even in the coast marshes occasionally an island-hill rises, with soil firm and fertile; and at other points cattle graze, whilst thousands of acres yearly are being drained and reclaimed and planted with rice. Besides the Mississippi the chief rivers are the Red, Sabine, Ouachita, and Pearl; the entire river navigation of the state reaches nearly 3800 miles, and there are also several considerable lakes.

The mean temperature of Louisiana is from 60 to 75 F., the climate being softened by the waters within and around the state, the profuse rainfall (47 to 73 in.), and the breezes from the Gulf. The vegetation in most parts is luxuriant. The forests are dense with trees—pine, cypress, oaks, cottonwood, magnolia, poplar, beech, &c. Fruits are abundant, oranges and figs the most important. The staple crops are cotton, sugar, rice, and maize. The Louisiana cotton crop is about a tenth of the whole crop of the Union; its rice crop is a half of the total produce of the States; and in some years the sugar crop of the state makes 95 per cent. of the produce of the Union. Wine is also made.

The principal manufactures are shingles and tanks, cotton-seed oil, machinery, tobacco, and clothing and boots and shoes (by machinery), besides the cleaning and polishing of rice and the refining of sugar and molasses. The only mineral of importance is rock-salt, which is found in inexhaustible quantity at Petit Anse on Avery's Island; but hematite iron ore and sulphur have also been discovered, besides lignite of little, if any, value.

Louisiana is divided, not into counties, but parishes to the number of 59. The other officials are elected in the usual manner, but the judges of the supreme court are appointed by the governor for a term of twelve years. Those of the courts of appeal are elected by the General Assembly for eight years, and in the country districts and in New Orleans the judges of the district courts are appointed by the governor, being elsewhere elected for four years. The civil law prevails in Louisiana,

a code based on the Code Napoleon having been adopted in 1825. The state returns six members to congress. Education is fairly well provided for, and increased attention is being devoted to the free schools. The State University and Agricultural and Mechanical College is at Baton Rouge, the State Normal School at Natchitoches; the Southern University, at New Orleans, is endowed by the state, and in the same city is the Tulane University, with departments for ladies and for training in the manual arts. See NEW ORLEANS.

The state forms part of the province of Louisiana, purchased from France in 1803, which occupied an enormously larger area than the state—namely, the whole western basin of the Mississippi from Mexico to the Canadian lakes. (See UNITED STATES, and the map there at p. 388.) In 1682 La Salle (q.v.) sailed down the river and claimed the country for France, naming it Louisiana in honour of Louis XIV., and planting a colony at a point 38 miles below the present site of New Orleans. After an unsuccessful attempt at colonisation by Iberville, the territory was handed over to the Mississippi Company, under John Law (see MISSISSIPPI SCHEME), and New Orleans was founded. The company collapsed in 1720, and Louisiana reverted to the crown in 1732. It was ceded to Spain in 1762, retroceded to France in 1800, and sold to the United States by Napoleon, for 60,000,000 francs, three years later, being admitted as a state in 1812, although the portion between the Mississippi and Pearl rivers was not actually acquired until the Florida purchase of 1819. The battle of New Orleans (8th January 1815) and several changes in the constitution are the only noteworthy events in its history until the civil war. Louisiana seceded in January 1861, and New Orleans was captured on 24th April 1862. More than a hundred battles were fought within the limits of the state, leaving ruin behind, whose effects are felt to this day. Prosperity, however, is returning, and is established on a basis more sound and satisfactory than of old. The finances of the state are in a healthy condition, her bonds nearly at par. Since 1877 political disturbances and outbreaks which had followed the period of reconstruction have ceased, railways have been extended, and the assessed valuation of property enormously increased; and Louisiana's chief troubles have been from the bursting of the levees, although none have proved so disastrous as the terrible flood of 1874, when one-sixth of the state was inundated. See C. Gayarre, *History of Louisiana* (3d ed. 4 vols. New Orleans, 1885).

Population.—The principal cities are New Orleans, Shreveport, Baton Rouge (the capital), and Monroe, all the subject of separate articles. The population is very mixed. The negroes in the country districts are somewhat in excess of the whites, of whom about one-sixth each are of French (some Acadian), German, or Irish descent. Those of French descent are called Creoles—a term which in Louisiana does not imply any admixture of African or Indian blood. There are also a number of Spanish and Italian descent. In most of the southern parishes French is habitually spoken by the people; and Spanish also is still retained. Pop. (1820) 153,407; (1860) 708,002, including 326,726 slaves and 18,527 free coloured people; (1880) 939,946; (1890) 1,118,587.

Louis Napoleon. See NAPOLEON.

Louis-Philippe, king of the French, born in Paris, 6th October 1773, was the eldest son of Louis-Philippe Joseph, Duke of Orleans. He received at his birth the title of Duke of Valois, and afterwards that of Duke of Chartres. His education was entrusted to the care of the cele-

brated Madame de Genlis. He entered the National Guard, and became a member of the Club of Friends of the Constitution, afterwards that of the Jacobins. Along with his father, he renounced his titles, and assumed the surname of Egalité. He showed both courage and capacity in the wars of the republic; but his situation became very dangerous after the unsuccessful battle of Neerwinden (1793), in which he commanded the centre. He was included in the order for arrest issued against his general-in-chief, Dumouriez, and on the 4th April escaped along with him into the Austrian territory. He sought in Switzerland a place of security for his sister Adelaide, wandered about amongst the mountains for four months, and accepted a situation as teacher of geography and mathematics in a school at Reichenau, near Chur, assuming the name of Chabaud-Latour. He afterwards wandered for some time in the north of Europe, and then went to the United States, where he spent three years. In 1800 he took up his abode at Twickenham, near London, with his two younger brothers, both of whom soon after died. In 1809 he married Marie Amelie, daughter of Ferdinand I. of the Two Sicilies. On the fall of Napoleon he hastened to Paris, where he was received with distrust by Louis XVIII. After the second Restoration he recovered his great estates, which the imperial government had sequestrated. Disliked by the court, he was very popular in Paris. The revolution of 1830—the 'July revolution'—having ended in a victory of the constitutional party over the republicans, he was appointed lieutenant-general, mainly on the proposal of the banker Lafitte and of General Lafayette. Throwing to the winds the divine right of the Bourbons, he accepted to reign as the elect of the sovereign people, under the tricolor flag of the republic and of Napoleon. He had against him the ultra-royalists and the republicans, and identified his rule with the *bourgeoisie*, who supplied him with a policy, ministers, and money, in return for their ascendancy. He was dubbed with the nickname of *roi-citoyen*, his system was called that of *Justice-milieu*, and his advisers were set down as *doctrinaires*. He reigned for the material interests of France, and for those of the House of Orleans; himself a most wealthy king, the country prospered under his rule, and the middle classes amassed considerable riches. Unfortunately, his kingship rested on a democratic basis, to which it grew more and more untrue. The revolution of 1830 had been an event of European importance, and rang in a revival of liberalism in many states where Louis-Philippe would have thought it quixotic to give it diplomatic or military assistance. Nor could he countenance the socialistic and communistic doctrines made popular among the republicans at home by Proudhon, Louis Blanc, and others. The parliamentary franchise rested on a franchise which limited the electors to the aristocracy of wealth and their hangers-on. The peasantry and working classes were ignored, and left a prey to political agitators. The political corruption of the *bourgeoisie*, and its wholesale bribery by the king, united all extremists in a cry for electoral reform. Louis-Philippe ran the gauntlet of eight attempts at murder, which all failed. A man of great ability, but of little character, he was by fear carried, with his ministers, into paths of reactionary violence. The royalistic statesman Royer-Collaud joined Odilon Barrot and the republican Left in resistance to the muzzling of newspapers. Trial by jury was tampered with. Prince Louis-Napoleon Bonaparte seized this opportunity of acting twice the part of a pretender (1836, 1840). The Duke of Orleans' death in 1812 left the throne without a direct heir apparent.

Republicans, socialists, communists became more and more threatening. In vain did Louis-Philippe provide, by campaigning in Algeria, an outlet for the military spirit of his subjects; in vain did he fix their attention on foreign affairs by supporting the kingship of Mehemet Ali in Egypt. A home-policy of reform banquets, hit upon by the republican leaders as their most suitable form of attack, and severely repressed on the part of the government by recourse to an obsolete law of the 'ancien régime,' led to violent debates in the Chamber, in which Thiers, then in the opposition, helped to weaken the position of the prime-minister Guizot. Yet parliamentary means were about to foil the republican deputies, when the Paris mob rose in arms on the 22d and 23d of February 1848, with the complicity of the regular troops, the national guards, and the municipal police. Louis-Philippe dismissed Guizot, and promised reforms; but it was too late. He was compelled to abdicate, and, amidst the indifference of almost every Frenchman to his fate, ended a reign remarkable for the wave of liberalism in which it took its rise and the whirlwind of democracy that swept it away. Deserted by his courtiers, he fled to the coast of Normandy along with his queen, concealed himself for some days, and at length escaped to Newhaven under the name of Mr Smith. He died at Claremont, 26th August 1850.

See the articles BOURBON, FRANCE, GUIZOT, ORLEANS (DUKE OF); works by the Marquis de Flers (1892) and Imbert St Amand (1893), Crétineau-Joly (2 vols. 1862), A. Dumas (2 vols. 1852), Nouvion (4 vols. 1861), Villault de Germainville (3 vols. 1870-76), Vantbault (1889), Villeneuve (1889), and Hamel (1890).

Louisville, the largest city of Kentucky, a port of entry and capital of Jefferson county, is situated on the Ohio, 130 miles below Cincinnati. The river here forms a series of rapids—the 'Falls of the Ohio'—descending 22 feet in 2 miles; except at high water steamboats pass these by a canal. The city, which covers about 20 sq. m., is handsomely built, with wide and regular streets, on a level plain, and sloping up from the river. It has a Roman Catholic cathedral and 150 other churches, a law school, four medical colleges, colleges of dentistry and of pharmacy, a school of pharmacy for women, and a good system of public schools. Here also is the State institution for the blind; altogether there are some forty public and private charitable institutions. Louisville is the greatest market for tobacco in the world, and has large pork-packing establishments, distilleries, and tanneries. Extensive manufactures of ploughs, furniture, castings, gas and water pipes, machinery, flour, and cement are also carried on. The city is the terminus of a number of railway lines; the Ohio is crossed here by two railway bridges, one of them nearly a mile long. Louisville was founded in 1778, and in 1780 named in honour of Louis XVI. of France, whose troops were then assisting the Americans in the war of independence. A great part of the town was destroyed by a cyclone in March 1890. Pop. (1880) 123,758; (1890) 161,165.

Loulé, a town in the extreme south of Portugal, 10 miles from the coast. Pop. 14,418.

Jumping-ill, or TREMBLING, a disease epidemic or endemic in sheep and lambs in cold spring weather, characterised by tremblings, loss of power, contraction of the gullet, and odd motions like involuntary 'jumping' (leaping). The brain is affected, and sometimes the lungs and heart.

Lourdes, a French place of pilgrimage in Hautes Pyrénées, 12 miles SSW. of Tarbes by rail. Pop. 6517. The town nestles at the foot of a high rock on a plain bounded to southward by the foot hills of the Pyrénées. The site was a Roman

military station, and was successively held by Vandals, Visigoths, Franks, Basques, Saracens, Albigenses, English (after 1360), and the lords of Be. en. Here, in a niche above one of the caves of the Massabielle rocks, the Blessed Virgin is said to have appeared at noon on the 11th February 1585 to a poor girl fourteen years of age, called Bernadette Soubirous; the apparition was seventeen times repeated during the succeeding six months. A spring rising from the spot, which was hitherto unknown to exist, was endowed with miraculous powers; and many miracles were reported. Crowds flocked to the place; and the barriers erected by the sceptical local authorities (1858) were soon afterwards removed by command of the emperor. The Bishop of Tarbes then appointed a commission of ecclesiastics and scientists to inquire into the extraordinary events that had occurred at Lourdes during the last six months. After investigations extending over three years, the commission decided in favour of the apparition of the Blessed Virgin Mary, the ecstasies of Bernadette, and the miracles wrought by the water of the spring. A great basilica (1876) now adorns the scene of the miracles, and on a level with its crypt has been added the church of the Rosary (1889) for the accommodation of the pilgrims who visit the spot. The most important pilgrimage is the National pilgrimage in August, numbering, in 1897, 60,000 persons. The miracles and other notable occurrences are duly recorded in the *Annales de Lourdes*, conducted by the Fathers of the Immaculate Conception, to whose care the grotto and its appurtenances have been confided.

See works on the subject by H. Lasserre; Colin (1889); Father Clarke, S.J. (1887); Barbe (trans. by Alice Meynell, 1894); and Zola's famous novel, *Lourdes* (1894).

Loourenço Marques, or LORENZO MARQUES, a Portuguese station on Delagoa Bay, east coast of Africa. Pop. (1896) 2692, of whom 1544 were Portuguese, English, Italians, &c. It is the terminus of the railway to Pretoria, which was open to the Transvaal frontier (52 miles) in 1887, and all completed in 1895. In the Boer war of 1899-1900 it was the scene of much intrigue, and hence Kruger sailed to Europe. See DELAGOA BAY.

Louse and **Lousewort**. See LICE, PEDI-CULARIS.

Louth (pron. soft *th*, as in *lath*), a maritime county of the province of Leinster, and the smallest county in Ireland, is washed for 49 miles on the east, from Carlingford Lough to the river Boyne, by the Irish Sea. The average width of the county is 10 miles. Pop. (1841) 128,240; (1881) 77,684; (1891) 71,638. Area, 202,123 acres—89,815 under tillage. Potatoes, oats, barley, and turnips are the principal crops; 40 per cent. of the total area is under grass. The surface is flat, with the exception of a range on the north, which culminates in Carlingford Mountain (1935 feet), overlooking the bay of that name. The soil of the level districts is fertile, and agriculture reaches a high state of efficiency. Coarse linens are manufactured. The fisheries are valuable, especially the oyster-fishing in Carlingford Lough. The chief towns are Drogheda, Dundalk, and Aubree. Louth, which anciently formed part of the territory of Orgial or Arghal, was occupied by De Courcy in 1183, and formed into a county by King John in 1210. It abounds with Celtic antiquities, some of great interest. There are two round-towers, at Monasterboice and at Dromiskin. At Mellifont are the remains of a beautiful abbey. In Drogheda several ruined abbeys are still visible, as also at Louth and Carlingford. But the most interesting of all the relics of antiquity are the sculptured crosses of Monasterboice, of which the larger is 18 feet in

height. The county returns two members to the imperial parliament.

Louth (hard *th*, as in *lath*), a municipal borough of Lincolnshire, on the rivulet Lual, at the foot of the Wolds, 27 miles E.N.E. of Lincoln, contains a beautiful parish church in the Perpendicular style, built in the 13th and rebuilt in the 15th century, with an octagonal spire (1501) 288 feet in height, 'one of the noblest in England,' and an Edward VI. grammar-school. Ruins of Louth Park Abbey, built by the Cistercians in 1139, exist $\frac{1}{2}$ mile E. of the town. Iron foundries, carpet-factories, breweries, and carriage-works are in operation. Louth is connected with the Humber by a canal (1761). Pop. (1851) 10,467; (1891) 10,040. See the corporation records, ed. by Goulding (1892).

Louvain (Ger. *Löwen*, Flemish *Leuven*), a city in the Belgian province of Brabant, 19 miles by rail E. of Brussels. In the 14th century the town was rich, prosperous, and large (200,000 inhabitants), due to its cloth manufactures and its position as the capital of Brabant (from 994). In 1382 the townsmen revolted against their rulers, and the harsh punishment meted out to them drove large numbers away to England. The town was the seat of a celebrated university, founded in 1426. In the next century it had 6000 students, but was suppressed in 1797. Reconstituted in 1817, it was in 1835 transferred to private hands, but is still a Catholic university, with about 1600 students. The library contains 250,000 vols. The old walls, forming a circuit of five miles, have been demolished. The modern town covers only part of the enceinte, the rest being occupied by gardens. A statue of Father Damien was erected in 1894. A severe blow was struck at Louvain's prosperity by a terrible visitation of the plague in the 16th century. The modern industry is confined chiefly to bell-founding, brewing, and the manufacture of leather, paper, lace, starch, and chemicals. The town-house is a richly-decorated Gothic building (1448-69); the church of St Peter has a beautiful flamboyant roof-loft, a wrought-iron chandelier by Quentin Matsys, and some good pictures; in St Gertrude's Church are fine carved oak stalls. The Weavers' Hall (1317) was appropriated by the university in 1679. Pop. (1877) 33,917; (1891) 40,698. In 891 King Arnulf gained here a great victory over the Northmen, and built a castle against them. It used to be known as Caesar's Castle; a few fragments of it still remain. See Histories by Pict (1839) and Molanus (1861).

Louviers, a town in the French department of Eure, 16 miles S. of Rouen, has a Gothic cathedral of the 13th to the 15th century, and celebrated cloth (since 1681) and ticking manufactures, besides spinning-mills, dye-works, &c. Pop. 9273.

Louvois, FRANÇOIS MICHEL LE TELLIER, MARQUIS DE, the war-minister of Louis XIV., was born in Paris, 18th January 1641. His father was Chancellor and Secretary of State in the war department; the son joined him as assistant-secretary in 1662, and became war-minister in 1668. The first great task he set himself was to organise the armies of France. He created a standing army, gave it a corps of officers recruited by compulsion from among the nobility, established commissariat and hospital services, and founded the *Hôtel des Invalides* and various orders of merit. In the drilling of the armies he had a ready agent in Martinet, whose name is not yet forgotten in military life. His labours bore their fruit in the great war that ended with the peace of Nimeguen (1678). During the following years Louvois took a leading part in the capture of Strasburg, in 1681, in time of profound peace, and in the persecution of the Protestants through the

dragonnades after the Revocation of the Edict of Nantes. Louvois, a man of strong will, was overbearing and autocratic, brutal and cynical, unscrupulous in his means, but consistent and single in his aims—the aggrandisement of France and the maintenance of his own position. He died suddenly on 16th July 1691. See Life by C. Rousset (6th ed. 4 vols. 1879); and Chotard's *Louis XIV., Louvois, Vauban* (1890).

Louvre (Fr. *Louvre*, 'the opening'), an ornamental opening of a turret shape, placed on the roof, to allow the smoke or foul air to escape from large apartments, such as halls, kitchens, &c. These were particularly required in ancient times, when the fire was placed in the centre of the room, and there was no chimney to carry off the smoke. They are frequently used as ornaments where not required for use, and are then glazed and made into lanterns (q.v.). The sides of the louvre were lined with horizontal overlapped boarding, with a space between the boards, which let out the smoke without

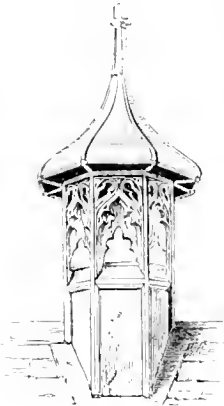

Louvre.

admitting the rain. Hence, this sort of boarding, frequently used for the windows of bell-towers, &c., acquired the name of *louvre-boarding*.—For the palace of the Louvre, see PARIS.

Lovage (*Ligusticum*), a genus of plants of the natural order Umbellifera, allied to Angelica; the fruit is elliptical; each carpel has five sharp somewhat winged ribs; and there are many vittæ in the interstices. Common Lovage (*L. officinale*, or *L. Levisticum*) is a native of the south of Europe, with ternate decomposed leaves, and obovate, wedge-shaped leaflets. It is sometimes cultivated in gardens, and, notwithstanding its strong and peculiar odour, is used as a salad plant. Its roots and seeds are aromatic, acrid, and stimulant, and are used to cure flatulency and to excite perspiration. A liquor called *lovage* is made from them.—Very similar in appearance and qualities is the only British species, Scottish Lovage (*L. scoticum*), a native of the sea-coasts. It is eaten, both raw and boiled, by the Shetlanders. The flavour is aromatic, but acrid and very nauseous to those unaccustomed to it.

Lovat, SIMON FRASER, LORD, was born about 1676 at Tanich in Ross-shire. About the beginning of the 14th century his ancestor and namesake, after whom the clan Fraser were called in Gaelic *MacShim*, 'sons of Simon,' had migrated from Tweeddale to Inverness-shire; and Hugh, his grandson, had been made Lord Lovat in 1131. Our Simon was educated at King's College, Aberdeen, took his M.A. in 1695, having the year before accepted a commission in a regiment raised for King William. In 1696 his father, on the death of his grand-nephew, Lord Lovat, assumed that title; and Simon next year attempted to abduct the late lord's daughter and heiress, a child only nine years of age. Failed in this, he seized and forcibly married her mother, a lady of the Athole family—a crime for which he was found guilty of high treason and outlawed. After four years of petty rebellion (during which, in 1699, he succeeded his father as twelfth Lord Lovat),

on Queen Anne's accession, in 1702, when the Athole family became all-powerful, he fled to France, but a twelvemonth later returned to Scotland as a Jacobite agent. He was at the bottom of the 'Queensberry plot,' in which he professed to reveal the policy of the exiled court and a plan for a Highland rising; but the discovery of his duplicity obliged him once more to escape to France. There, by one (the more probable) account, he was kept for some years a prisoner at Sammar; by another, turned Jesuit, and became a popular preacher. He was still the darling of his clan; and in 1714 they sent Major James Fraser as a sort of ambassador to bring him over. Next year his cousin's husband, the holder of the estates, having joined the rebellion, Simon found it his interest to take the government side; his clan at once left the insurgents; and for this good service he obtained a full pardon, with possession of the Lovat territory. His life for the next thirty years was active in intrigues for the consolidation of his influence; and the man who had heretofore had audience with Mary of Modena and the Grand Monarque now sought and obtained a sponsor for his first-born in George I. In the '45 Lovat tried to play a double game, sending forth the clan under his son to fight for the Pretender, whilst to his friend and neighbour, Duncan Forbes of Culloden, he made constant professions of loyalty. Culloden lost, and his castle fired by Cumberland's soldiery, he fled to an island on Loch Morar, where he was found hiding in a hollow tree. He was brought up to London, on the way being sketched at St Albans by his friend Hogarth, and, after trial by impeachment before the House of Lords, was beheaded on 9th April 1747. At his trial he defended himself with ability and dignity, and he met death gallantly, Horace's line on his lips, 'Dulce et decorum est pro patria mori.' He is buried in the Tower. A finished courtier, a good scholar, and a most elegant letter-writer, Lovat was also a ruffian, a liar, a traitor, and a hypocrite. A cultured savage, he stands as the incarnation of the clan system at its worst, the very opposite of Scott's 'Fergus MacIvor.' During the lifetime of the lady he had ravished he twice more married—in 1716 Margaret, daughter of the Laird of Grant, by whom he was father of Colonel Simon Fraser (1726-82) and three others; in 1733, Primrose Campbell, of the Argyll family, whom he had inveigled into a house of ill-fame in Edinburgh, and who also bore him a third son, Colonel Archibald Fraser (1736-1815).

See Hill Burton's *Life of Lovat* (1847), and works there cited; also the Autobiography of Dr Alexander Carlyle, Sir W. Fraser's *Chiefs of Grant* (1883), Mr Henderson's article in the *Dict. of Nat. Biography* (vol. xx. 1889), and *Major Fraser's Manuscript*, edited by Colonel A. Fergusson (2 vols. 1889).

Love, FAMILY OF. See FAMILY OF LOVE.

Love-apple. See TOMATO.

Love-bird, a name given to various small parrots, but especially to those included in the genus *Agapornis*. These are at home in the forests of the Ethiopian region, are predominantly green in plumage, and are very affectionate both in their native haunts and in captivity. The name is, however, extended to the species of other genera and from other regions.

Lovedale, an important educational and mission station in South Africa, 650 miles N.E. of Capetown, and about 40 miles W. of King William's Town. It was founded in 1841, and has been generously supported by the Free Church of Scotland. Besides giving a general education,

it aims specially at training teachers for native schools, and teaching such arts of civilised life as printing, bookbinding, telegraphy, smith and carpenter work, and the like. Its highest numbers—490 in 1876—have not since been equalled. There was printed at Lovedale in 1887 a brief individual record of over 2000 natives, as well as a few hundred Europeans, who had been educated here, and the result was creditable in a surprising degree to the institution. See KAFFERS.

Love-feasts. See AGAPE.

Lovelace, RICHARD, Cavalier lyricist, was born at Woolwich in 1618, the eldest son of a Kentish knight of old family. Wood tells us he had his education at the Charterhouse, and at Gloucester Hall, Oxford, where his uncommon beauty and graceful yet modest manners made him the darling of the fair. Naturally he found his way to court, and went on the Scotch expedition in 1639, after which he retired awhile to his estate. In April 1642 he was committed to the Gatehouse at Westminster for presenting to the House of Commons a petition from the royalists of Kent 'for the restoring the king to his rights, and for settling the government,' and was only released on bail of £40,000. In the *Journals* of parliament this large sum is put as *personal bail* to the extent of £10,000, with a *society* for £5000. Thus Lovelace throughout the struggle was confined to the mortifying part of a prisoner on parole, but he spent his estate in the king's cause by furnishing money to his brothers and friends. In 1646 he took part in the siege of Dunkirk, and was flung into prison on returning to England in 1648. During this imprisonment he revised his poems, and in 1649 published *Lucasta*, the name formed from *Luc casta*, his epithet for his love, Lucy Sacheverell, who married, says Wood, another on the stray report that Lovelace had died of his wounds at Dunkirk. After the king's execution he was set at liberty, but his estate was spent, and his last years were darkened by dejection and distress. He closed the tragedy of his life in a mean lodging in Gunpowder Alley, near Shoe Lane, in 1658. Next year his brother collected his poems as *Lucasta: Posthumous Poems* (1659). His tragedy, *The Soldier*, and his comedy, *The Scholar*, were never published, and are lost. Most of Lovelace's work is slovenly, obscure, and in-spid, but his name survives secure of its immortality from two of the most faultless lyrics in the language—'To Althea from Prison' and 'To Lucasta on going to the Wars.' The best edition of his poems is that edited by W. C. Hazlitt (1864).

Love-lies-bleeding. See AMARANTH.

Lover, SAMUEL, artist, novelist, song-writer, and dramatist, was born in Dublin, the son of a Protestant stockbroker, 24th February 1797. In 1818, after three years' study, he established himself there as a marine painter and miniaturist; and to about the same date belongs his debut in literature, though it was not till 1832 that his first book appeared, *Legends and Stories of Ireland*, illustrated, like many of its successors, with his own etchings. *Rory O'More* (1836) at once became popular, and, as dramatised by him, ran through 108 nights; still, its success has been quite eclipsed by *Heavenly Body* (1842), a rollicking story of Irish life. Meanwhile, in 1837, Lover settled in London, and wrote much for the periodicals, till, in 1841, his eyesight beginning to fail, he started an entertainment, called 'Irish Evenings,' which was a hit both at home and in America (1846-48). In 1856 he received a pension; and he died at St Helier, Jersey, 6th July 1868. Of his songs may be mentioned 'The Angel's Whisper,' 'Molly Brown,' 'The Low-backed Car,' and 'The Four-leaved Shamrock.' See LIVES by Bernard (1874) and Symington (1880).

Low Archipelago, the most easterly group of Polynesian islands, known also as Paumotu, Tuamotu, Pearl or Dangerous Islands. They are about eighty in number, very flat and thinly peopled (8000 in all), and surrounded by coral atolls. Since 1846 they are under a French protectorate. There are rich pearl-fisheries off these islands. See POLYNESIA.

Low Countries, the Netherlands. See HOLLAND, BELGIUM.

Lowe, SIR HUDSON, the custodian of Napoleon in St Helena, was born at Galway, 28th July 1769. Entering the army in 1787, he served in various parts of the Mediterranean, and in 1808 capitulated at Capri to the French. But in the following year he helped to conquer Zante and Cephalonia, and then for nearly two years acted as governor of Santa Maura, Ithaca, and Cephalonia. He was afterwards for some time attached to the Prussian army commanded by Blücher. On 14th April 1816 he reached St Helena as governor of the island. Napoleon had landed there on the 17th October of the previous year. The strictness of Lowe's watch upon the disturber of the peace of Europe brought down upon him much obloquy, and exposed him to bitter and rancorous attacks from Napoleon's friends and admirers, especially from O'Meara (*Napoleon in Exile*, 1822). He was even assaulted in London in 1822. His defence of his conduct and acts may be read in his *Memorial relatif à la Captivité de Napoléon à Ste-Hélène* (2 vols. Paris, 1830) and in W. Forsyth's *Captivity of Napoleon at St Helena* (3 vols. 1853). In 1825 Lowe became commander of the forces in Ceylon. He died 10th July 1844. See NAPOLEON; and R. C. Seaton, *Sir Hudson Lowe and Napoleon* (1898).

Lowe, ROBERT. See SHERRBOOKE.

Lowell, a manufacturing city of Massachusetts, the birthplace of Whistler, on the Merrimack River, and at the junction of several railways, 25 miles N. by W. of Boston. The site is uneven and hilly, and the river falls 33 feet, affording great hydraulic power, which is controlled by a chartered company. Steam-power, however, is now extensively used in the large mills and workshops. These, the principal of which are also in the hands of corporations, include a great number of cotton and woollen factories; 2,500,000 yards of cotton are produced here in a week. Among the other manufactures are leather, paper, and iron goods, chemicals, carriages, &c. Lowell was incorporated in 1826. The operatives were for years gathered from the rural districts fifty or a hundred miles round, and lived in boarding-houses built and owned by the corporations, and kept under strict management. Foreign emigration has brought a large resident manufacturing population. Evening and technical schools, reading-rooms, a free library, and lectureships are maintained, and unusual attention is paid to the well-being of the work-people. Pop. (1880) 59,485; (1890) 77,696.

Lowell, JAMES RUSSELL, poet, essayist, and diplomatist, was born in Cambridge, Massachusetts, February 22, 1819. His copyright acts came of a family distinguished in many ways. His father, a friend of Cooper at Channing's, was minister of the West Church in Boston. The future poet entered Harvard College in his sixteenth year and graduated in 1838, but without any special rank. His abilities, however, were early recognised; all his youthful contemporaries were sure of his coming fame. His father had an unusually large library, not restricted to theological subjects, and the son was left to browse in it. The variety and extent of his reading was the foundation of his future scholarship, and the source of those stores of allusion and anecdote for

which his writings and conversation are equally remarkable. The severe studies which made him a scholar came long after his university course.

In his twenty-second year he published *A Year's Life and other Poems*. He studied law, but never seriously sought to practise. In company with Robert Carter, in 1843, he edited *The Pioneer*, a monthly magazine, with Hawthorne, Poe, and Whittier for contrilators; but after three issues the publishers failed. In 1844 he published a second volume of poems, in which were seen growing power and greater promise. In the same year he married Maria White, a beautiful and intellectual woman, herself the author of some charming poems. In 1845 he published *Conversations on the Old Poets*, an original and suggestive book, but immature in style and treatment. In 1846, at the outbreak of the Mexican war, he published a satiric poem in the Yankee dialect, purporting to have been written by a rustic named Hosea Biglow, and edited by the Rev. Homer Wilbur, an amusing pedant, in which the policy of the pro-slavery party and the conduct of the United States government toward an unoffending neighbour were held up to scorn and ridicule. It was apparently a trifle, but it had immediate and universal success; and from this slight beginning came the *Biglow Papers*, perhaps the highest expression of the poet's genius, and beyond doubt the first of modern satires in English. It is the soul of New England character; racy with its droll humour, and sparkling with its unborrowed wit; but its rare qualities are fully appreciated only by those to whom the rustic life and the dialect are familiar.

The year 1848 was productive and memorable. It was the year of European revolutions and of boundless hopes among enthusiasts for the future of mankind. A great many serious poems were written at this time, and formed a third volume. He wrote *The Vision of Sir Launfal*, one of the best, as it is one of the most popular, of his poems; also *A Fable for Critics*, given to the world anonymously—a series of witty and dashing sketches of American authors. It is full of puns and grotesque rhymes, done in a 'happy-go-lucky' style, but is not ill-natured, and has a basis of good sense. After all these years it is seen that his judgments of men and tendencies were almost prophetic.

In 1851 he visited Europe with his wife, then in delicate health, and returned in 1852. Her death occurred early in 1853. In 1857 he was married in Portland, Maine, to Miss Frances Dunlap, who died in London in February 1885.

In 1855 he was appointed professor of Modern Languages and Literature in Harvard College, to succeed Longfellow, and thereupon went to Europe to prosecute his studies. While still holding this chair, and delivering lectures which were memorable, he edited the *Atlantic Monthly*, beginning in 1857, and afterwards, along with Charles E. Norton, the *North American Review*, from 1863 to 1867. *Commencement Ode*, a notable poem, was written in 1865 in honour of the alumni who had fallen in the war of the rebellion. *The Cathedral* (1870), a poem marked by profound thought, but lightened by some playful passages, was suggested by a visit to Chartres. Three patriotic odes were written (1875-76), one for the anniversary of the battle of Concord, one for the Washington Elm in Cambridge, the other for the centennial of the Fourth of July.

His prose writings—*My Study Windows* and *Among my Books*—have high qualities, and are likely to be enduring. Some of the essays, such as those upon Chaucer, Dante, Shakespeare, and Dryden, are masterpieces of literary art. The sentences are animated, not so much with crackling epigrams as with airiness; they are (perhaps

too frequently) studded with recondite allusions, and are often lustrous with poetic images. It is always evident that it is a poet who writes. To the author's friends the most delightful of his prose works is *Fireside Travels*, containing his recollections of *Cambridge Thirty Years Ago*.

The second series of *Biglow Papers* appeared during the civil war, in which the poet's three nephews and other near relatives gave their lives for the Union. This volume is naturally graver and upon a higher plane of thought and sentiment. Certain passages (probably the best he has written) show an intensity of feeling rare in human experience; in others the scenery and the seasons are painted with loving touches; and the rude dialect, so far from being a blemish, lends an indefinable charm to the tenderness and to the descriptive art.

Lowell was an ardent abolitionist, and from the first gave himself unreservedly to the cause of freedom. In this, as in all things, he showed himself an heir of Puritan blood, faithful to the right, without regard to popularity. In such poems as *The Present Crisis* he came to his countrymen with a 'burden' like a Hebrew prophet.

He was appointed in 1877 minister of the United States to the court of Madrid, and was transferred in 1880 to that of St James, where he remained until 1885. One of his volumes, *Democracy* (1886), contains some of the brilliant addresses he made while in England, and one volume, *Heartsease and Rue* (1888), embraces later poems, including a few written long before for the *Atlantic Monthly*.

The post of minister to Great Britain is the highest in the gift of an American president, and that Lowell should have been sent to represent his country in the old home of the race sufficiently shows the estimation in which he was held, for he had never been a politician. He wrote a life of Hawthorne in the 'American Men of Letters' series (1890); *The Old English Dramatists* appeared posthumously in 1893. He lived at Elmwood (in Cambridge), the house in which he was born; and there he died 12th August 1891. His *Collected Writings* were published in 10 volumes (1890-91). See *The Poet and the Man*, by the present writer (1893), and Dr E. E. Hale's *Lowell and his Friends* (1899).

Lowell Institute, at Boston, Mass., founded by John Lowell (1799-1836), a Boston merchant. See **LECTURES**.

Lower Empire. See **BYZANTINE EMPIRE**.

Lowestoft, a municipal borough and seaport on the Suffolk coast, 118 miles N.E. of London by rail, and 49 from Ipswich, has of late years rapidly grown in favour as a watering-place, its healthfulness and the picturesqueness of its neighbourhood, combined with its easy means of access to the Broads (q.v.), all tending to its popularity. The older part of the town, which lies to the north, is built on a cliff facing the sea, on its summit being a lighthouse (1874) 123 feet above the sea-level, whilst at its base, on the Ness—the most easterly point of land in England—stands another lighthouse (1806). The modern part of the town, which has a fine esplanade 800 yards long, extends southwards into the parish of Kirkley, and is separated from the old town by the harbour, formed partly by two piers extending seawards 1300 feet, and partly by Lake Lothing, a piece of water stretching inland two miles; adjoining the harbour is a dock (1883) with a depth of water at low tide of 13½ feet, and extensive fish markets (1865-83), the property of the Great Eastern Railway, who in 1887 conveyed inland from the port 26,935 tons of fish, principally herrings, mackerel, and soles. On the new South Pier is a splendid pavilion, opened in 1890. Other features of interest in the town include the parish church (of which Whiston, the mathe-

mation, and Potter, the translator of Greek plays, were former vicars), 183 feet in length, and surmounted by a tower and spire 120 feet high, dating from the first half of the 14th century; town hall (1857), noticeable for its stained-glass windows; hospital (1882), with accommodation for thirty in-patients; and Bellevue Park (1874), not far from which was found the clay formerly used in making Lowestoft china. The principal incidents in the history of the town have been visitations of the plague in 1349, 1547, 1579, and 1603, on the last occasion the disorder raging with such fury that 280 persons died within five months and 316 in the year; its occupation in 1613 by Cromwell, who entered the town at the head of 1000 troopers, and, seizing several royalists, sent them prisoners to Cambridge; its partial destruction by fire in 1644; a great naval engagement, which took place off the coast on the 3d June 1665, when the Dutch were defeated with loss of eighteen ships; and the landing of George II. on his return from Hanover, 14th June 1736. Pop., including that of Kirkley, (1801) 2509; (1841) 5304; (1891) 19,150. See works by Gillingwater (1790) and Nall (1866).

Low German. See GERMANY, Vol. V, p. 186.

Low Latin, a term often applied loosely to the Latin spoken and written after the fall of the Roman empire, as well as during the middle ages. The process of deterioration from classical models had already begun even in the time of Cicero, but it rapidly grew until were formed gradually in different divisions of the dismembered empire those distinct varieties out of which grew the modern Romance tongues. See ROMANCE LANGUAGES.

Lowndes, WILLIAM THOMAS, a London bookseller (died 1843) to whom we are indebted for *The Bibliographer's Manual of English Literature* (4 vols. 1834; see BIBLIOGRAPHY) and *The British Librarian* (1839).

Low Sunday, in the Roman Catholic Church, is the first Sunday after Easter. It is so called in contrast to the great festival whose octave it ends. In France and Germany it is usually called *Quasimodo*, from the first word of the introit (1 Peter, ii. 2) in the Mass.

Lowth, ROBERT, a learned English bishop, was born November 27, 1710, at Winchester; his father was rector of Buriton. He was educated at Winchester, whence, with a reputation both as a scholar and poet, he passed to New College, Oxford, in 1730. In 1741 he was appointed professor of Poetry, and hence arose his famous *De Sacra Poesi Hebræorum Prælectiones Academicæ*, published in 1753. In 1750 Bishop Hoadley conferred on him the archdeaconry of Winchester, and in 1753 the rectory of East Woodhay in Hampshire. Lowth became D.D. of Oxford in 1754, prebendary of Durham and rector of Sedgely in 1755, a Fellow of the Royal Societies of London and Gottingen in 1763, Bishop of St Davids in 1766, of Oxford a few months after, of London in 1777, and died November 3, 1787. Besides his lectures, his two principal works are *Life of William of Wykeham* (1758) and *Isaiah, a new Translation* (1778). Lowth's *Prælectiones* was one of the first books that treated the Bible poetry as literature, and though most of his criticism, save the doctrine of poetic parallelism, is long since obsolete, he gave a new direction to the biblical criticism of Herder and later critics.

Loyola, BENATUS DE, is the name by which history knows Miguel Lopez de Recalde, the youngest son of Bertram de Loyola and Marina Salez de Behi, who was born in the year 1491 at his ancestral castle of Loyola, in the Basque province of Guipuzcoa. After the scant training of that age in letters, he was received as a page in the court of Ferdinand; but the restraint and inactivity of

court-life were distasteful to his enthusiastic mind, and under the auspices of his relative, the Duke of Najara, he embraced the profession of arms. The details of his career as a soldier display both the excellency and the irregularities of his ardent temperament, thrown undirected among the temptations as well as the duties of a military life. Of his bravery and chivalrous spirit many remarkable instances are recorded, and one of these proved the turning-point of his career. In the defence of Pampeluna he was severely wounded in both legs, one being fractured by a cannon ball, and the other injured by a splinter; and having been taken prisoner by the French, he was by them conveyed to his paternal castle of Loyola, where he was doomed to a long confinement. After an operation, the results of which had well-nigh proved fatal, he eventually recovered; and with his returning strength he appears to have resumed his habitual levity. In order to remove a deformity which had resulted from the first setting of his wounded limb, he consented to the painful remedy of having it re-broken in order to be reset. After this operation his convalescence was even more slow; and, the stock of romances by which he was wont to relieve the tedium of confinement having been exhausted, he was thrown upon the only other available reading, that of the *Lives of the Saints*. The result was the creation of a spiritual enthusiasm equally intense in degree, although in kind very different from that by which he had hitherto been drawn to feats of chivalry. The spiritual glories of St Francis or St Dominic now took, in his aspirations, the place which had been before held by the knights of mediæval romance. With souls like his there is no middle course; he threw himself, with all the fire of his temperament, upon the new aspirations which these thoughts engendered.

Renouncing the pursuit of arms, and with it all other worldly plans, he tore himself from home and friends, and resolved to prepare himself for the new course which he contemplated by a pilgrimage to Jerusalem. With a view to his immediate preparation for this holy task, he retired in the garb of a beggar to the celebrated monastery of Montserrat, where, on the vigil of the Feast of the Annunciation, in 1522, he hung up his arms, as at once a votive offering significant of his renunciation of the works of the flesh, and an emblem of his entire devotion to the spiritual warfare to which he was from that moment vowed. From Montserrat he set out barefooted on his pilgrimage, the first step of which was a voluntary engagement which he undertook to serve the poor and sick in the hospital of the neighbouring town of Manresa. There his zeal and devotion attracted such notice that he withdrew to a solitary cavern in the vicinity, where he pursued alone his course of self-prescribed austerity, until he was carried back, utterly exhausted, to the hospital in which he had before served. To this physical exhaustion succeeded a state of mental depression, amounting almost to despair, from which, however, he arose with spiritual powers renewed and invigorated by the very struggle. From Manresa he repaired by Barcelona to Rome, whence, after receiving the papal benediction from Adrian VI., he proceeded on foot, and as a mendicant, to Venice, and there embarked for Cyprus and the Holy Land. He would gladly have remained at Jerusalem, and devoted himself to the propagation of the gospel among the infidels; but finding no encouragement, returned to Venice and Barcelona in 1524.

Taught by his first failure, he now resolved to prepare himself by study for the work of religious teaching, and with this view was not ashamed to return, at the age of thirty-three, to the study of

the very rudiments of grammar. He followed up these elementary studies by a further course, first at the new university of Alcalá, and afterwards at Salamanca. In both places he incurred the censure of the authorities by some unauthorised attempts at religious teaching in public, and eventually he was induced to repair to Paris for the completion of the studies thus repeatedly interrupted. Here, again, he continued persistently to struggle on without any resources but those which he drew from the charity of the faithful; and here, again, he returned to the same humble elementary studies. It was while engaged in these studies that he first formed the pious fraternity which resulted in that great organisation which has exercised such influence upon the religious, moral, and social condition of the modern world. From the close of his residence in Paris Loyola's history has been told in the history of his order (see JESUITS). From the date of his election as the first general of his society he continued to reside in Rome. To him are due, not alone in the general spirit, but even in most of their details, all its rules and constitutions; from him also originated several works of general charity and benevolence, the germs of great institutions still maintained in Rome. But the great source of his influence upon the spiritual interests of the world is his well-known *Ecclesiastical Spirituality*, of which an account has been already given. He died at Rome, prematurely, worn out by his long austerities, July 31, 1556. He was beatified in 1609, and canonised in 1622.

His life has been written in almost every European language. The biographies of Ribadaneira (1572), Maffei (1585), Bonhours (1679), Daurignac (1865), Denis (1885), are well known; and there are books by Stewart Rose (1891), Father Hughes (1892), Gothein (Halle, 1896), and H. Joly (trans. 1899).

Loyson. See HYACINTHE.

Lozère, a department in the south of France, derives its name from Mont Lozère, one of the summits of the Cévennes (q.v.). It comprises the arrondissements of Mende, Florac, and Marvejols. Area, 1996 sq. m.; pop. (1872) 135,190; (1891) 135,527. Capital, Mende. The department forms the south-east extremity of the central uplands of France, and embraces the highest peaks of the Cévennes (Pic de Finiels, 5584 feet). These mountains are the birthplace of numerous rivers, which go down to feed the Rhone, the Garonne, and the Loire. In the mountains the climate is severe, and little grain is produced. Potatoes, chestnuts, fruits, hemp, and flax are the more important products, and silkworms are bred. The department contains some of the grandest scenery of France in the eroded limestone districts of the 'Causse.'

See Martel's *Les Cévennes* (1890), and Betham-Edwards, *The Roof of France* (1889).

Luang Prabang, a Shan state on the Upper Mekhong, ceded to France by Siam, with other territory, in 1893. See SHANS.

Lubbock, SIR JOHN, BARON AVEBURY (erc. 1900), son of the astronomer and mathematician, Sir J. W. Lubbock (1803-65), was born in London, April 30, 1834, and educated at a private school and at Eton. At fourteen he entered his father's banking-house, and in 1856 became a partner. He was chosen honorary secretary to the Association of London Bankers, first president of the Institute of Bankers, and served in the International Coinage Commission, as a member of the Public School Commission, the Advancement of Science Commission, the Education Commission, and the Gold and Silver Commission. In 1865 and 1868 he contested West Kent unsuccessfully in the Liberal interest, but was returned for Maidstone in 1870; and on losing his seat in 1880 he was returned

for London University—since 1886 as a Liberal Unionist. As a politician he has devoted himself chiefly to financial and educational subjects, and has succeeded in passing more than a dozen important public measures, including the Bank Holidays Act (1871), the Bills of Exchange Bill, which regulates the whole law relating to cheques, bills, and promissory notes, the Ancient Monuments Bill (1882), and the Shop Hours Bill (1889). He is an honorary graduate of Oxford, Cambridge, Edinburgh, Dublin, and Würzburg; was vice-chancellor of the university of London from 1872 to 1880; is a trustee of the British Museum; and has acted as president of many of the scientific societies, being president of the British Association in 1881. President of the London Chamber of Commerce, and chairman of the London County Council, he is best known as a man of science for his researches on the ancient vestiges and remains of man, and on the habits of insects, especially bees and ants.

Besides more than a hundred memoirs to various societies, he has published *Prehistoric Times, as illustrated by Ancient Remains and the Manners and Customs of Modern Savages* (1865); *The Origin of Civilisation and the Primitive Condition of Man* (1870); *The Origin and Metamorphoses of Insects* (1874); *On British Wild-flowers, considered in Relation to Insects* (1875); *Addresses, Political and Educational* (1879); *Scientific Lectures* (1879); *Monograph of the Thysanura and Collembola: Fifty Years of Science*, an inaugural address to the British Association (1881); *Ants, Bees, and Wasps* (1882); *Flowers, Fruits, and Leaves: On Representation: The Senses and Instincts of Animals* (1888); and *The Pleasures of Life* (1887; 20th ed. 1890; 2d series, 1889); *The Beauties of Nature* (1892); *The Use of Life* (1894); and an interesting work on *The Scenery of Switzerland* (1896).

Lübeck, a free city of Germany, and great port on the river Trave, 12 miles from the Baltic, and 40 by rail N.E. of Hamburg. It was founded by Saxons in 1143, in place of a former Wendish town of the same name, lower down the Trave. The foundations of its prosperity were laid by Henry the Lion, Duke of Saxony, who gave it a charter, and took unusual pains to encourage its budding commerce. He also built a cathedral, and transferred the see of Oldenburg to Lübeck. Frederick Barbarossa not only confirmed, but greatly enlarged, its privileges, and Frederick II. made it a free city of the empire. From this time it made rapid progress as a trading centre: it was from the first one of the most influential members of the Hanseatic League (q.v.), and eventually its head. The city became in short the commercial metropolis of the Baltic and northern Europe. This proud position was due in some measure to the liberal encouragement of several successive emperors, but in still greater measure to the prudent guidance of the oligarchical council, composed of men elected from the families of the great merchants. The decay of Lübeck was necessarily involved in the decay of the Hanseatic cities generally. The eventful dictatorship of Wullenwever (1533-37) was the last dying effort of the League. Full administrative rights were not conferred upon the burghers or citizens until 1818. At the present time the constitution, embracing a senate (14 members) and a representative assembly (120 members), is thoroughly democratic in spirit. The French held Lübeck from 1806, when they captured it and plundered it—except for nine months in 1813—down to the treaty of Vienna, which made it a free town of the German Confederation. The traditional connection with Hamburg and Bremen, the last survivors of the Hanseatic League, was kept up till 1879. Nevertheless, in 1866 Lübeck joined the North German Confederation, and in 1868 the Customs Union (*Zollverein*).

The free city possesses 115 sq. m. of territory,

including the port of Travemünde, near the mouth of the river. The total population was 76,485 in 1890, of whom 63,590 were in the city of Lübeck (44,799 in 1875). The industries are more varied than important, the chief being the manufacture of cigars and vinegar, brewing, brandy distilling, soap-boiling, and iron-founding. Lübeck is the great centre for trade between Hamburg and the cities of Germany on the one side and the countries that border the Baltic on the other. The imports reach an annual value of about 93 millions, and the exports of 8 millions. This traffic is mostly transit business: for instance, corn, timber, spirits, linseed, paper, tar, and butter are brought from Russia; timber, iron, steel, and copper from Sweden; butter and corn from Denmark and Finland; wines and spirits from France; coals (45,000 tons), grinding and other stones, and iron wares from Great Britain; and petroleum from North America. The port is entered annually by an average of 2300 vessels of 443,000 tons. The Trave was deepened to 15 feet in 1878-82. A scheme for a canal to connect Lübeck with the Elbe has been postponed owing to the Kiel-Elbe Canal.

The streets of the city are mostly wide and pleasant. The city-wall was demolished in 1802 or converted into promenades. The churches include the handsome Gothic St Mary's, first erected in 1163-70, though the existing edifice dates from 1276-1310, with two towers 407 feet high, old sarcophagi, masterpieces of old German sculpture, and pictures by Overbeck and others; the cathedral, founded in 1173, and enlarged in the 14th century, with a tower 394 feet high, and an altarpiece by Menning; St James's, built before 1227, and St Peter's, before 1163, which contain fine old paintings and monuments; and St Egidius, which has an excellent organ. The town-house is the most notable amongst the secular buildings; it is built of red and black glazed bricks. The hospital of the Holy Spirit, dating from the 13th century, is adorned with admirable wood-carving. There are a school of navigation, a library of 98,000 vols., ethnographic, antiquarian, zoological, and art collections, &c. The state debt amounts to £692,380.

See Max Hofmann, *Geschichte der Freien- und Hanse-Stadt Lübeck* (1889-90); Pauli, *Lübeksche Zustände im Mittelalter* (1872); and Waitz, *Lübeck unter Wollentwürf* (3 vols. 1855-56).

Lübke, WILHELM (1826-93), author of a score of books on the history of art in Germany, France, Italy, &c., was born at Dortmund, studied at Bonn and Berlin, taught the history of art at Stuttgart and Karlsruhe, and was finally director of the art galleries of Baden.

Lublin, capital of a Polish government, stands on a sub-tributary of the Vistula, 96 miles by rail S.E. of Warsaw. It was once a great commercial city, has a 13th century cathedral, and was plundered by the Mongols. There are manufactures of tobacco, beer, candles, soap, &c., and a large trade in corn and wool. Pop. (1871) 24,456; (1891) 53,137. Here was signed in 1569 the treaty of union between Lithuania and Poland.—The *government* has an area of 6497 sq. m. and a pop. (1891) of 1,059,959.

Lubricants, unguents interposed between surfaces in machinery which work on one another, with the object of lessening the friction (q.v.), and thereby diminishing the wear and tear, and lessening the waste-power taken up in overcoming friction. Various unguents are in use: animal fats and oils, such as tallow, sperm-oil, lard, &c.; vegetable oils, as, for example, olive-oil and rape oil; and many mineral oils. The particular unguent best suited for any purpose is a matter of considerable importance. Where the pressure between the two surfaces is great it is necessary to

use oils with body or thickness, since the lighter oils are readily squeezed out from position. Sperm-oil, for instance, is a very good lubricant, but not so satisfactory for heavy loads and high temperatures. Many oils again, especially vegetable oils, deteriorate much faster in use than others by evaporation of their volatile constituents.

Luca della Robbia. See ROBBIA.

Lucan, GEORGE CHARLES BINGHAM, EARL OF, British general, was born on 16th April 1800, and succeeded his father, the second earl, in the title in 1839. He was put to school at Westminster, and on leaving entered the army. He accompanied the Russian troops under General Diebitsch as a volunteer against the Turks in 1828. As commander of a division of cavalry in the Crimea he fought at the Alma, Balaklava, and Inkermann (see CRIMEAN WAR). Appointed lieutenant-general in 1858 and G.C.B. in 1869, he became field-marshal in 1887. He died 10th November 1888.

Lucania, a province of ancient Italy, south-east of Calabria, and bordering on the Gulf of Tarentum. It was inhabited by an Oscan people, and corresponds nearly to the present province of Potenza and part of Salerno.

Lucanus, M. ANNEUS (39-65 A.D.), whose *Pharsalia* heads the epic poems of the silver age, was born at Corduba, capital of the province Bœtica, the centre of Roman influence in Spain, and of a literary school which lasted on into mediæval times. Among the leading Corduban families were the Annæi, of whom Annæus Seneca, the rhetorician, had three sons—M. Annæus Seneca, the Gallio of the Acts of the Apostles; L. Annæus Seneca, the philosopher; and M. Annæus Mela, who married Acilia, daughter of Acilius Lucanus, a noted orator of the place, and by her became father of M. Annæus, who received the cognomen Lucanus from his maternal grandsire. Rome's irresistible attraction for the outlying world had already drawn thither Seneca, the philosopher; and Mela, with his wife, followed, to place their son, an infant prodigy, under his uncle's eye for the usual training in rhetoric and moral science. Young Lucan took kindly to the hereditary culture, and under Palamon the grammarian, and Cornutus the Stoic, of whom Persius the satirist was also an admiring pupil, he became proficient in the merits which won the applause of the lecture-room. Indeed, his aptitude for prose and verse was ominous of the fatal fluency which evolved the first three books of the *Pharsalia* while yet in his teens. Hatred of tyranny was the prevailing note of the patricians, and Lucan shared the hopes of his order as to Nero's government, not inauspiciously begun. But the imperial pupil of Seneca ere long betrayed the lower side of his character; and a morbid vanity, courting the applause of the circus and the theatre, made him the rival of charioteers and poets, and, among these, of Lucan. At first the young emperor and the young poet were friends, and Nero's favour had conferred on the latter the quaestorship, with which he entered the curia as well as the augural priesthood. But imperial vanity 'bears no brother near the throne,' and Nero's self-love was mortally wounded when, in a great public contest, the palm went over his head to Lucan. The emperor's marked discourtesies were returned by his successful rival with satire and with redoubled efforts to outshine him, till Nero was stung into forbidding Lucan either to publish poems or to recite them. About that time the Pisonian conspiracy had been hatching, and the emperor's increasing follies and barbarities hastened its development. Lucan became one of its ringleaders, and with characteristic impetuosity was already discounting its success, when the news

came to him that it was discovered and he himself betrayed. At first his demeanour was worthy of a Stoic; then his courage declined, till it sank so low that—quite falsely, it is believed—he accused his own mother Aelia of being privy to the plot, in hopes that the matricidal emperor might be conciliated by a similar crime! But in vain. He was ordered to die, and, having had his veins opened, he bled to death in the bath, reciting an appropriate passage from one of his poems.

Except a few fragments, we now have nothing of Lucian's many writings but the *Pharsalia* in ten books, recounting the mighty duel of Pompey and Cæsar Julius for the empire of the world. Though always freely criticised, its acceptance in antiquity and in modern times has been great. From Tacitus to Sealiger and Macaulay it has found praise and censure in pretty even proportion. Its defects are mainly those of youth—inspired youth trained in a school where epigram and antithesis were sought after as the chief merit of style. It is frequently bombastic, sometimes obscure; so unsteady, moreover, in its delineation that it is open to doubt whether its hero is not Cæsar Julius after all, rather than the Pompey who is characterised as 'Magnus' throughout. When at its best its merits are those of eloquence rather than poetry; and for its many brilliant and apt 'sententia' it justly enjoys an 'immortality of quotation.' Its Roman patriotism strikes so true a note that with all pioneers of liberty it has been a favourite—particularly in the England of the 17th century. Indeed, the historian of the Long Parliament, Thomas May, not only wrote a respectable translation of it, but also a still more respectable continuation in the language and verse of the original. Rowe's translation, considered by Johnson to be one of the best in the English language.

There are other English translations in verse by Marlowe (Bk. i.), Sir Ferdinand Gorges, and E. Ridley (1897); and in prose by H. T. Riley (1853). There are editions by Oskindorp, Barnann, Haskins (1887), Hosius (Teubner, 1893), and Francken (1895-98).

Lucaris, CYRIL, a Greek theologian, was born in Crete in 1572, studied at Venice and Padua, and subsequently in Geneva, where he became imbued with the Calvinist doctrines. Taking holy orders, he rose by 1621 to the highest dignity in the Greek Church, Patriarch of Constantinople. An outline of his public career will be found under GREEK CHURCH (Vol. V. p. 397). In June 1637 he was seized in Constantinople, hurried on board a vessel, and it was never properly ascertained what became of him. According to some he was strangled in the ship which bore him off; according to others, he suffered this fate in a castle on the shores of the Black Sea. His doctrines have been repeatedly condemned by Greek synods.

Lucarne, a Dormer Window (q.v.), especially in a church spire.

Lucas van Leyden, whose proper name was Lucas JACOBSZ, Dutch painter and engraver, was born in Leyden in 1494. An extremely precocious artist, he painted a picture of St Hubert when only twelve, and the celebrated print, 'Mahomet and the Monk Sergius,' was engraved when he was only fourteen. But he was not enrolled in the guild of St Luke at Antwerp in 1522. He practised successfully almost every branch of painting, and as an engraver ranks as the equal of Albert Dürer in everything except fertility of design. His range of subjects was very wide, and embraced events in sacred history, incidents illustrative of the manners of his own period, and portraits. He was on terms of intimacy with Mabuse, and held friendly intercourse with Dürer, whose talents he admired without professional

jealousy. He died in 1533, having been confined to bed for six years. Amongst his most celebrated pieces are the 'Hill of Calvary,' by some regarded as his masterpiece, 'Adam and Eve expelled from Paradise,' 'Ecce Homo,' 'A Girl and a Dog,' the 'Card Party,' 'St Jerome,' and 'Christ healing a Blind Man.'

Lucca, chief town of an Italian province, is situated in a plain, bounded by picturesque hills and irrigated by the Serchio, 14 miles by rail N.E. of Pisa. Pop. (1894) 77,300. 'Lucca the Industrious' has a great trade in olive oil and silk, the latter manufacture introduced in the end of the 11th century. The cathedral of St Martin, begun in 1063, has a cedar crucifix reputed to have been brought to Lucca in 782; this Volto Santo ('Sacred Countenance') is mentioned by Dante. The church also contains several fine paintings, the tomb of Maria Guinigi (cf. Ruskin's *Modern Painters*, vol. ii.), and valuable archives. There are nearly forty other churches, some dating from the 7th and 8th centuries. A splendid aqueduct (1820) supplies the town with water from the Pisan hills. The municipal buildings (1578) contain a valuable collection of paintings. Lucca is exceptionally rich in artistic and scientific institutions. The city was a bishopric as early as 347, and in 1726 was made an archbishopric. The environs abound in delightful villas. In a charming valley, 16 miles N. of the town, are situated the mineral baths of Lucca, which have been famous since the 15th century. Their temperature varies from 96° to 136° F.—The province, which has an area of 558 sq. m. and a pop. (1895) of 289,890, is famed for the fertility of its soil and the superiority of its agriculture. The Lucchesi are a frugal, shrewd race; numbers leave home in search of employment, and they form a large proportion of the itinerant figure-vendors, organ-grinders, and stucco-workers of Europe.

Lucca (anc. *Luccæ*) was made a Roman colony in 177 B.C. It was erected into a duchy by the Lombards, and its merchants traded in English wool from the 9th, but more especially from the 12th century. The town had a most chequered history down to 1369, when it became an independent republic, which lasted till 1797. In 1805 it was erected into a principality by Napoleon for his sister Elisa Bacciochi, and in 1815 passed to Maria Louisa of Spain, queen of Etruria. Her son, Charles Louis, ceded it to Tuscany in 1847, on obtaining possession of Parma and Piacenza.

Lucena, a town of Spain, 36 miles S. by E. of Cordova, is famous for its wine and breed of horses. Pop. 21,271.

Lucera (the ancient *Luceria* of the Samnite war), a town of Southern Italy, 12 miles by rail N.W. of Foggia, has a cathedral dating from 1302, and a famous ruined castle of Frederick II., who died, however, at the neighbouring castle of Fiorentino. Pop. 14,067.

Lucerne (*Medicago sativa*), a species of Medick (q.v.), one of the most valuable of the leguminous plants grown for the supply of green food to cattle. It is a native of the south of Europe, and has been cultivated there from an unknown antiquity. It is not very largely grown in Britain, but in some places very successfully, chiefly in the drier parts of the south of England. The climate of many districts of Scotland is not too cold for it. It is largely cultivated in some parts of North and South America. It endures great droughts, its roots penetrating very deep into the ground. Sir John Bennet Lawes states that at Rothamsted he has found it the best of all forage-crops for a drought. It delights in a rich and calcareous soil, and never succeeds on damp soils or tenacious clays. It is a

perennial, and if kept free from weeds affords good crops for six, seven, or more years. It is sown in rows, at 10 or 14 inches apart, and may be mown several times in a year, growing very quickly after being mown. The quantity of produce is very great—sometimes from 20 to 30 tons per annum—and few other forage-plants are ready for use so early in spring. Lucerne has a rather erect stem, leaves with three obovate-oblong toothed leaflets; purplish-blue or sometimes yellow flowers in many-flowered racemes, and pods twisted two or three times round. It ought to be mown before it comes into flower, as it then becomes fibrous and less nutritious. In Spanish lands it is called *Alfalfa*.

Lucerne (Ger. *Lucern*), the capital of a Swiss canton, 59 miles SE. of Basel, 147 SSE. of Strasbourg, and 177 NNW. of Milan. It is very beautifully situated at the point where the Reuss issues from the north-west extremity of the Lake of Lucerne, and is partly surrounded (on the north) with medieval towers. Near the lake, rising from the middle of the Reuss, is an old tower, which is said to have been a lighthouse (*Lucerna*) in Roman times, whence the name of the town. Outside one of the gates is the Lion of Lucerne, hewn (1821) out of the solid rock after a model by Thorwaldsen, a monument to the Swiss guard who perished at the Tuileries in 1792. Near by is the Glacier Garden, with rocks illustrating the action of ice. The town is a busy centre for tourists and summer visitors to Switzerland. Pop. (1894) 21,778.—The canton has an area of 579 sq. m. and a pop. (1894) of 135,813. The soil is fruitful in the valleys; in the more mountainous parts the rearing of cattle is carried on to a great extent, large quantities of cheese being made. The highest elevation in this canton is 6998 feet, a peak of Mount Pilatus. The inhabitants are mostly of German race and language, and belong to the Roman Catholic Church, except about 5650 Protestants, to whom the free exercise of their religion was first accorded in 1828. The canton threw off the yoke of Austria in 1332, and, joining Schwyz, Uri, and Unterwalden, formed the nucleus of the future Swiss Confederation. The constitution of Lucerne is a representative democracy. The legislative body is the Great Council, one member being elected by every 1000 citizens; the executive is vested in seven members, who are not of the council. See SWITZERLAND.

THE LAKE OF LUCERNE, called also *Vierwaldstattersee* ('Lake of the Four Forest Cantons'—Uri, Unterwalden, Schwyz, and Lucerne), is one of the most beautiful sheets of water in Europe. In shape it resembles roughly a cross with a crumpled stem; its shores are mostly steep and rocky. Length from Lucerne to Flüelen, 23 miles; average breadth, about $\frac{1}{2}$ mile; area, 44 sq. m. The chief places on its banks are Lucerne, Küssnacht, and Alpnach at the north-west, and Flüelen near its south-west extremity. It forms part of the St Gothard route, and is navigated by steamboats, but is liable to sudden and violent storms. The lake is rich in associations of William Tell (q.v.) and his story.

Lucian, one of the most interesting, graceful, and amusing of Greek writers, was born in Samosata, the principal town of Commagene in Syria, probably about 125 A.D. Intended by his parents to be a sculptor, Lucian early asserted his own decided preference for letters. Having learned Greek and studied under some teacher of rhetoric, he practised as an advocate for a short time in Antioch. He then turned to the composition of show speeches (epideictic oratory) and to reciting them as a means of making a living. His professional career thus made him a travelling artist; and in the quest for suitable festivals at which to deliver his declamations he travelled through Asia

Minor, Greece, Macedonia, Italy, and Gaul. Having thus made a fortune and a name, he settled in Athens, still the intellectual capital of the world, and there devoted himself to the study of philosophy. There, too, he produced a form of literature hitherto, as he claims, unknown. This was humorous dialogue. In his old age he reverted to his first love, recitation. He accepted a good appointment in Egypt, where at an advanced age, eighty or ninety years, he died. A Semite by race but not by education, a subject of Rome but not a Roman, a writer of Greek but not a Greek by birth, Lucian was by circumstances singularly freed from every tie, prepossession, or prejudice which might have stood at all in the way of his deriving the largest possible amount of amusement out of the world. Nor was this all that fortune did for him; she brought him into the world at an age when the old faiths, the old philosophy, the old literature, were all rapidly dissolving in decay, and when what the new would be was an insoluble problem. For satire, whose nature is simply to deny, never was there a fairer field; and Lucian revelled in it. The old faith was gone, and the inherent absurdity of retaining the old deities without the old belief is brought out by Lucian in the *Dialogues of the Gods*, *Dialogues of the Dead*, *Prometheus*, *Chiron*, *Mentippus*, *Leucanippus*, and others. Whether the old philosophy was the more disgraced by the shallowness or the vices of those who professed it in Lucian's time it would be hard to tell from his *Symposium*, *Halius*, *Bion Praxias*, *Drupetr*, &c. The old literature had been displaced by novels or romances of adventure of the most fantastic kind, which Lucian parodies in his *True Histories*. In fine, there is no department of life with which he is unacquainted or from which he fails to raise a laugh. His extensive travels gave him abundant material, and his extensive reading gave him ancient instances to confirm and illustrate his own experiences. His Greek, though not absolutely pure Attic of the best times, is but little removed from it; and this is to be accounted for by the fact that he learned Greek as a foreign language, and consequently picked it up from Plato and not from the streets. Apart from the purity of his Greek, his style is perfectly delightful, simple, pellucid, and sparkling. The *editio princeps* is dated 1496, Florence. The editions by Hemsterhuis and Reitz (*eum versione Latina et notis rariorum*, 1730-45) and by Lehmann (1822-29, in 9 vols.) have not yet been superseded. See works by Croiset and Sommerbrodt (1888), and *Lucian, the Syrian Satirist*, by Lieut.-col. Hine (1900).

Lucifer (Lat., 'light-bringer'), the morning-star; see PLANETS. The church fathers attached this name to Satan in the belief that Isaiah, xiv. 12, which refers to the king of Babylon, contained a reference to the Prince of Darkness; cf. Luke, x. 18.

Lucifer Matches. See MATCHES.

Lucigen, one of the most powerful artificial lamps, and specially well adapted for lighting large spaces, whether open or covered. The light, which is produced by burning creosote oil, is brilliant and diffused, and does not cast black shadows like the electric light, as the flame gives a broad glow resembling very much the effect of the sun. The construction of the lamp is exceedingly simple. The tank or oil-reservoir is a plain circular drum, to the top of which the burner is fixed. The burner-tube, E, extends to the bottom of the drum, passing through an outer tube F, which is pierced with holes through which the oil is strained, and passes down into the small well, L, in the bottom of the tank. The compressed air enters the drum at H, and forces the oil up the tube, E, to the oil cone I.

The heated air from the coil, C, enters the annular space between the oil-cone and burner, where the air and oil become amalgamated and escape in the form of a spray or vapour which is immediately inflammable. There are various forms of the

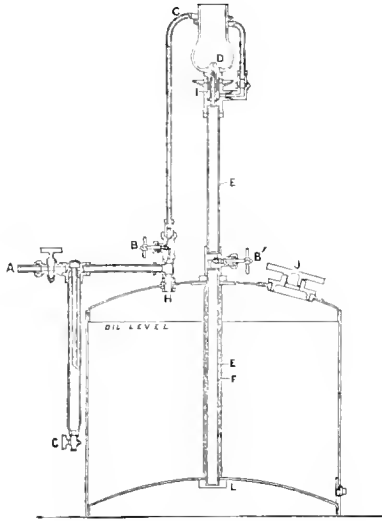

Section of a Lucigen Lamp:

A, air supply; B, stopcock for controlling supply of air to burner; B', stopcock for controlling oil-feed; C, coil for heating air; D, burner; E, burner-tube; F, strainer-tube; G, drip-cock for condensed moisture; H, air to drum; I, oil-cone; J, for oil supply; L, oil well.

Lucigen, which was first used in 1885; but for a universal lamp the vertical type worked by compressed air may be taken as the best, which, with about 18 lb. pressure at the burner, gives the most regular and effective light.

Lucilius, Roman poet, the creator of that form of poetic satire which was wielded so brilliantly by his successors, Horace, Persius, and Juvenal. He was born at Suessa Aurunca, in Campania, probably in 164 or 166 B.C. Other dates given or suggested are 148 and 180. He was on intimate terms with the Younger Scipio, under whom he is said to have served at Numantia, and of Lucilius. He was a thorough man of the world, and wrote in a bold, independent tone, choosing for his subjects contemporary events, persons, affectations, vices, &c. He enjoyed great popularity during his lifetime, so much so that at his death in 102, at Naples, he was honoured with a public funeral, although he had never held any public office. He wrote thirty books of *Satires*, of which nothing but fragments remain, preserved in great part by the grammarians. The best editions of these fragments are Lachmann's (Berlin, 1876) and L. Muller's (Leip. 1872), who also wrote *Leben und Werke des Lucilius* (1876).

Lucina ('the light-bringing'), a name applied both to Diana and to Juno; to the latter, Juno Lucina, as the especial divinity that presides over childbirth, corresponding to the Ilithyia of Greek mythology. See *JUNO*.

Lücke, GOTTFRIED CHRISTIAN FRIEDRICH, Protestant theologian, was born 21st August 1791, at Egeln, near Magdeburg, and was professor of Theology at Bonn (1818-29), and at Göttingen, where he died 14th February 1855. His great work is his commentary on John (1820-25; 3d ed. 1850-56); other works are on the Apocalypse (2d ed. 1818-52), and on New Testament Hermeneutics (1817).

Luckenwalde, a town of Prussia, 31 miles by rail SSW. of Berlin, has cloth and hat manufactures. Pop. 18,398.

Lucknow (*Laknau*), capital of the province of Oudh, and the fourth largest city in India, stands on the river Guntli, by rail 42 miles NE. of Cawnpore and 199 NW. of Benares. The city is interesting, not only as the capital of the former kingdom of Oudh, and for the memorable part it played in the Mutiny, but also as a centre of modern Indian life, a chief school of native music and poetry and of Mohammedan theology. The appearance of magnificence and splendour which the city presents when seen from the outside is not borne out by close internal inspection, though a vast improvement has been effected since the Mutiny. The chief architectural glory of the place is the Imambara or mausoleum of Asaf-ud-Daula, the fourth Nawab, who did so much to embellish Lucknow with magnificent buildings. This edifice, built in 1784, stands within the Machi Bhawan fort (built by Asaf's predecessor), and is now converted into a British arsenal. The Rumi Dorwaiza, a grand and massive gateway, leading out of the fort, the magnificent Residency palace, and the country palace of Bibiâpur, besides numerous minor buildings, were all erected by the same prince. The Jama Masjid or chief mosque, and the huge palaces of Chattar Manzil, Kaisar Bagh, Farhat Baksh, four royal tombs, and an observatory (head-quarters of the rebels during the Mutiny) are the most noteworthy amongst the remaining public buildings, though the palaces are remarkable for little else except their great size, debased style of architecture, and gaudy decorations. The educational establishments embrace Canning College, established in 1864, now with five departments; the Martinière College, where 120 soldiers' and civilians' sons are educated; and more than two dozen mission and other schools. The staple of the native industries is gold and silver brocade, besides which there are—muslins and other light fabrics, embroidery in gold thread and silk upon cotton and velvet, glass, clay-moulding, shawls, jewellery (but declining), and paper. There are here extensive railway workshops. Lucknow is a busy commercial town, trading chiefly in country products (grain, butter, sugar, molasses, spices, tobacco, oil-seeds), European piece-goods, salt, leather, &c. Pop. (1869) 284,779; (1881) 261,303; (1891) 273,028, of whom 20,000 were in the cantonments just outside the city; and in religion 160,000 were Shi'ite Mussulmans and the rest mainly Hindus.

The site of the present fort was originally occupied by a small village called Lakshmanpur, founded by a brother of Rama Chandra, the hero of the epic *Ramayana*. The city did not, however, rise into importance until it was made (1732) the capital of the independent state of Oudh (q.v.). Lucknow covered itself with glory by the stirring events of which it was the scene during the mutiny of 1857, and which have been enshrined in splendid verse by Tennyson. The insurrection broke out on the night of 30th May. Sir Henry Lawrence had already fortified the Residency and garrisoned it with 750 British troops. An attempt to check the advance of the enemy at a place 8 miles from the city was defeated on 29th June, and two days later the British were besieged. On 4th July Sir Henry Lawrence died, from a wound caused on the 2d by a bursting shell. Three times in succession the little garrison, commanded on the first occasion by Major Banks, on the last two by Brigadier Inglis, beat back the assaults of the enemy. On 22d September Havelock (q.v.) and Outram, with a relieving force, captured the Ahm-bagh (q.v.), and on the 26th reached the Residency. Again the siege was formed by the rebels, both of the

Residency and the Alma-bagh. The latter was succoured by Sir Colin Campbell on 10th November. Then, after driving the mutineers out of their two principal strongholds, Sir Colin reached the garrison in the city (16th November). Six days later the gallant Havelock died of dysentery. Sir Colin Campbell, leaving Ontram with 3500 men to hold the Alma-bagh till his return, escorted the civilians, and the ladies and children, to Cawnpore. In the first week of March 1858 he returned to the attack upon the rebels at Lucknow, who had meanwhile entrenched themselves in the city. It cost a week's hard fighting to subdue them (9-15th March): the issue ended the mutiny.

There are recent books on the mutiny and siege by Lady Inglis, *The Siege of Lucknow* (1892); Forbes Mitchell, *The Great Mutiny* (1895); and M'Leod Innes, *Lucknow and Oude in the Mutiny* (1895).

Luçon, an episcopal town of 6301 inhabitants in the south of La Vendée, on the railway from Nantes to Bordeaux, and on the canal of Luçon. Richelieu was Bishop of Luçon; and many battles were fought here in 1792-97.

Lucretia, the wife of L. Tarquinius Collatinus, famous for her heroic virtue. She was shamefully outraged by Sextus Tarquinius, whereupon she summoned her husband and a group of friends, and, after making them take a solemn oath to drive out the hated race of Tarquins from the city, plunged a knife into her heart. Of the poetic elaborations of the story the most famous is the long *Rape of Lucrece* of Shakespeare's youth. See BRUTUS.

Lucretius, TITUS CARRUS, Roman poet, lived in the first half of the 1st century B.C., but of the particulars of his life we really know nothing. A story was current some time after his death that he died raving mad from the effects of a love-potion administered to him by his wife Lucilia, and on this story Tennyson has founded a very striking and powerful poem; but it would seem to have been a malicious invention, started by some hostile critic, or possibly by an early Christian writer who took delight in assuming that a champion of unbelief and materialism must have come to a bad end. The great—indeed, the only—work of Lucretius is an essay in hexameter verse, 'On the Nature of Things' (*De Rerum Natura*), in six books, containing upwards of 7400 lines. The work was said, but on no good authority, to have been revised by Cicero. All we know is that Cicero once briefly alludes to it (*Epist. ad Quintum Fratrem*, ii. 9), observing that there are several flashes of genius in the poem, and that much skill is shown in the composition. This is a very fair criticism, and it has commended itself to general acceptance. The poem, we take it, was on the whole coldly received by Roman readers, and with the moderns Lucretius has never been a popular classic. The subject-matter of his work is not generally attractive, nor is the versification for the most part pleasing or harmonious. Lucretius aspired to popularise the philosophical theories of Democritus and Epicurus on the origin of the universe, with the special purpose of eradicating anything like religious belief, which he is always savagely denouncing as the one great source of man's wickedness and misery. In this he is terribly in earnest, and he is never so eloquent as when he is striking at this hated enemy. The often-quoted verse, 'Tantum religio potuit suadere malorum,' expresses his innermost conviction, and out of this springs his finest and most vigorous poetry. A calm and tranquil mind was his *summum bonum*, and the only way to it lay through a materialistic philosophy which teaches that immortality is an empty dream. To Lucretius this was a positively delightful thought; he hailed

it as a sure deliverance from the worst terrors which haunt men's minds. The universe, as it exists, was, he held, evolved out of ultimate elementary atoms, infinite in number, streaming downwards in void space, like a huge snowstorm; this, or something like it, was the theory of Democritus. Creation, as we understand it, is impossible; nothing can come out of nothing, neither can anything be destroyed; destruction is only a name for a change of substance. Life, mind, soul, &c. are simply parts of the man in the same sense as his limbs, and being in their nature corporeal, being, as we should say, functions of the body, they perish finally with the body, or at least so perish as to leave no survival of consciousness. All knowledge is derived from the senses, which are in fact our only test and criterion of truth. All phenomena can be explained by natural causes, and thus the door is closed against any belief in the divine or supernatural. Lucretius, in fact, is substantially in accord with modern materialism, and he often reminds us of some of the newest theories of modern science. For instance, he explains contagious diseases by the perpetual flying about in the air of minute particles, germs as we call them, injurious to life; and again, in his account of the various types of animal life as they successively appeared on the earth, we have something like anticipations of the 'survival of the fittest,' and of the Darwinian theory of evolution. Every now and then, indeed, there is quite a modern flavour about the doctrines of Lucretius. Still, it is as a poet that he has his chief interest for us, though the man himself, in his intense earnestness, no doubt put his philosophy before his poetry. A very readable book might be made up with the title 'The Beauties of Lucretius.' His poem abounds in strikingly picturesque phrases, such as only a great poet could have originated; scattered up and down in it are episodes of exquisite pathos and vivid description, perhaps hardly to be equalled in the whole range of Latin poetry. Now and then he allegorises some of the popular myths and legends, showing how they foreshadow moral truths, and in such passages he is one of the sublimest and most impressive of poets.

For a full discussion of Lucretius and his poetry, see Professor Sellar's *Roman Poets of the Republic* (1863); Professor Veitch's *Lucretius and the Atomic Theory* (1875); and *The Atomic Theory of Lucretius*, by John Masson (1884). The first edition of Lucretius was printed about 1473 at Brescia; this was followed in 1500 by the Aldine (published by Aldus), and in 1563 by the edition of Lambinus, which from that time held its place for upwards of three centuries as the standard text. In 1832 appeared the edition of the great German scholar Lachmann, in which the text was thoroughly revised, and on this in 1870 Munro greatly improved, adding a most valuable commentary and a close and vigorous prose translation. Creech's translation into English verse (1714) was the work of an enthusiastic admirer of the poet and his philosophy; it is on the whole a good piece of work, but is little known.

Lucullus, L. LICINIUS, a very distinguished Roman general, born about 110 B.C. In the first Mithridatic war he commanded the fleet as legate of Sulla. In 74 B.C., as consul, with Cilicia for his province, he defeated Mithridates (q.v.), and almost annihilated his army on its retreat. In 71 B.C. Pontus became subject to the Romans. The measures which Lucullus now introduced in the government of the province of Asia show that he was a just, wise, and humane administrator; but his troops grew disaffected on account of the strictness of his discipline. In the spring of 69 B.C. he marched into Armenia, and gained a complete victory over Tigranes. In the following year he gained another great victory at the river Arsianus over a new army led against him by Tigranes and

Mithridates; but the mutinous spirit of the legions daily increased, and soon he could do nothing. At last he was superseded by Pompey, and left Asia in 66 B.C. In conjunction with the aristocratic party, he attempted to check the increasing power of Pompey, and the attempt caused the coalition known as the first triumvirate. But he was ill fitted to act as leader against such unscrupulous men, and soon withdrew altogether from political affairs. During his public career he had acquired (but not unfairly) prodigious wealth; and he spent the remainder of his life surrounded by artists, poets, and philosophers, and exhibiting in his villas at Tusculum and Neapolis, and in his house and gardens at Rome, a luxury and splendour which became proverbial. He died about 57 B.C.

Lucy, St., a virgin who was martyred under Diocletian at Syracuse. She is the patron of the blind, and is commemorated on 13th December.

Luddites, bands of workmen who went about the midland counties of England between 1812 and 1818 destroying machinery, to the introduction of which they attributed the want of work consequent on the commercial depression. They took this name from one Ned Ludd, a Leicestershire idiot, who had in a passion destroyed some stocking-frames thirty years before, and their outrages commenced at Nottingham in November 1811, and extended during the following spring and summer through the counties of Derby and Leicester, and through Cheshire, Lancashire, and Yorkshire. In July 1816 they broke out with greater vigour, and destroyed every lace machine in Loughborough, while their leader openly declared his readiness to march 100 miles to destroy any machinery working under price. In October of the same year another party broke thirty machines in Leicester; but soon after, the riots of the Luddites are lost sight of in the wider and more formidable political riots which marked this period, and make the social history of 1816 little more than a long catalogue of disturbances. See *The Risings of the Luddites, Chartists, and Plug-drawers*, by Frank Peel (2d ed. 1888).

Lüdenscheid, a town of Westphalia, 19 miles ESE. from Elberfeld-Barmen, is the seat of numerous hardware manufactures, such as metal buttons, buckles, teaspoons and teapots, mountings for umbrellas and sticks, and musical instruments, besides iron-foundries and machine-shops. Pop. (1875) 8555; (1885) 15,067.

Luderitzland, a name sometimes given to Angra-Pequena (q.v.) and the adjoining territory, now part of German Namaqualand.

Ludhiana, capital of the Ludhiana district (area, 1375 sq. m.; pop. 618,835 in 1881), in Punjab, India, stands 8 miles from the south bank of the Sutlej, and on the Sind, Punjab, and Delhi Railway. It was founded in 1480 by the princes of Delhi, and is now a thriving corn-mart and has manufactures of Cashmere shawls, scarves, cottons, turbans, furniture, and carriages. Pop. 44,163. The shrine of a Mohammedan saint here attracts a large concourse of pilgrims every year.

Ludlow, a market-town and municipal borough of Shropshire, at the Corve's influx to the Teme, 28 miles S. of Shrewsbury. It is a very old and interesting place, with two noble monuments of antiquity. First, there is the massive Norman keep, 110 feet high, of the castle, where Prince Arthur wedded Catharine of Aragon, and died less than five months afterwards; where, in the banquetting-hall, Milton produced his *Comus*; and where, too, Butler wrote *Hudibras*. Captured by King Stephen, the Lancastrians, and the Round-heads, it was finally dismantled in 1689. Secondly, there is the cruciform collegiate church (restored

1863-91), Perpendicular in style, with a tower 130 feet high. The grammar-school, founded in 1282, and refounded in 1552, is almost the oldest in the kingdom; and one of seven gates still remains. From Edward IV.'s reign till 1867 Ludlow returned two members, then one till 1885. Stanley Weyman is a native. Pop. (1851) 4730; (1881) 5035; (1891) 4460. See works by Wright (1826-69) and Baker (2d ed. 1889); and for Ludlow formation, SILURIAN.

Ludlow, EDMUND, a sturdy English republican and regicide, was born of a good old family at Maiden Bradley, Wiltshire, in 1617; studied at Trinity College, Oxford; and at the outbreak of the Civil War was a student in the Temple. He volunteered into Essex's lifeguards, saw service under Waller and Fairfax, was returned in his father's room to parliament for Wiltshire in 1646, sat among the king's judges, and had a place in the council of state of the Commonwealth. In 1651 he was sent to Ireland as lieutenant-general of horse, and held the chief command for six months between the death of Ireton and the arrival of Fleetwood. He refused to recognise Cromwell's protectorate, and until his death took no further part in public affairs. Returned to parliament for Hindon in 1659, he urged the restoration of the Rump, held command again for a few months in Ireland, was nominated by Lambert to the committee of safety, and strove in vain to reunite the broken ranks of the old republican party. Four months after the Restoration he fled to France for safety, making his way to Vevey in Switzerland, where he lived in seclusion, troubled only by the dread of Cavalier assassins. After the Revolution he returned to England, but, the House of Commons presenting an address to William III, craving for his arrest, he returned to Vevey, and died there in 1692. Ludlow's *Memoirs* is one of the best contemporary sources of knowledge we possess, and its author was a man of solid, stubborn, and truthful temper. It covers the whole period from 1640 to 1688, and was first printed in three volumes in 1698-99; new ed. by Firth (1894).

Ludwigsburg, a town of Württemberg, 8 miles N. of Stuttgart. It grew up round a hunting castle founded in 1704 by Duke Eberhard Ludwig, is the second royal residence, and one of the principal garrison towns, of the kingdom; and has a military school and a royal castle, with picture-gallery and splendid gardens. Pop. (1885) 16,187. Ludwigsburg was the birthplace of D. F. Strauss, Justinus Kerner, Moricke, and Friedrich Vischer.

Ludwigscanal. See GERMANY, Vol. V. p. 172.

Ludwigshafen, a town of the Bavarian Palatinate, stands on the left bank of the Rhine, opposite Mannheim. It was granted town rights only in 1859, and has grown rapidly owing to its manufactures (soda, aniline dyes, wagons, &c.) and its trade in iron, timber, coal, and agricultural products. Pop. (1864) 3911; (1875) 42,093; (1885) 24,012; (1890) 33,216.

Luffa. See LOOFAL.

Lugano, a town in the Swiss canton of Ticino, stands on the north-west shore of the lake of the same name, 49 miles by rail N. by W. from Milan. In appearance the place is thoroughly Italian; villas stud the lower slopes of the hills embosomed in vineyards, olive and orange groves, chestnut and walnut woods. The church of Santa Maria degli Angioli has interesting works of art by Luini. An important cattle fair is held here in October. Mazzini and the Italian patriots made Lugano their headquarters for some time after 1848. From Monte Salvatore (2982 feet), in the vicinity, a magnificent view may be obtained. Pop. 6129.—The LAKE OF LUGANO, also called CERESIO, lies at

the southern foot of the Alps, 889 feet above sea-level. Its length is 14½ miles, its average breadth 1½ mile; area, 18½ sq. m. The depth varies very greatly, the maximum being 945 feet, whilst the average is only about 246 feet.

Lugdunum. See LYONS, LEYDEN.

Lugo (*Lucus Augusti* of the Romans), capital of a province in the north-west of Spain, is situated on the Minho, 72 miles by rail S.E. of Comma, and is still surrounded with old walls, high and thick, with towers. It has a cathedral built in 1129-77, and manufactures of linen and leather. It was celebrated as early as the time of the Romans for its warm sulphur baths. Pop. (1894) 19,701.—The *province*, a mountainous but agricultural region, drained by the Minho and its tributary the Sil, and rich in minerals that are but little extracted, has an area of 3787 sq. m., and a pop. (1887) 431,644.

Lugo, a town of Italy, 18 miles by rail W. of Ravenna, has a trade in corn, hemp, wine, and a celebrated fair (all September). Pop. 9189.

Lugsail. See SAIL.

Lugworm. See LOBWORM.

Luini, or LOVINO, BERNARDINO, a painter of the Lombard school, was born about 1470 at Luino, near the Lago Maggiore. He developed his skill in the school of Leonardo da Vinci; indeed many of his works used to be attributed to Leonardo. Luini's principal charms are a certain poetic grace and beauty. He died some time after 1530. He painted frescoes in the Ambrosian Library, in the Brera Gallery, and in the church of St Maurizio, all at Milan. Other works hang in the church at Lugano. His best-known easel-works include 'The Virgin Enthroned' (Brera), 'The Daughter of Herodias' (Louvre), 'Christ disputing with the Doctors' and 'Vanity and Modesty' (London), &c. Luini is one of the five great painters whose 'supremacy' Ruskin has affirmed. See G. C. Williamson's *Bernardino Luini* (1899).

Luke (*Loukas*—i.e. *Lucas*, perhaps shortened from *Lucanus*, as Silas from Silvanus), a companion of St Paul, mentioned in Col. iv. 14 as 'the beloved physician'; his absence from the list in Col. iv. 10-11 leads to the inference that he was a Gentile, and his name is suggestive of an Italian origin. Church tradition since Eusebius has made him a native of Antioch in Syria, and will have it that he was one of 'the seventy' mentioned in Luke, x. 1, 17, that after Pentecost he laboured in Bithynia, Greece, and Gaul, and that, after attaining a good old age, he died a martyr. The further tradition that he was a painter cannot be traced to an earlier date than the 8th century. He is named for the first time as author of the third canonical gospel in the Muratorian canon (2d century); and tradition has ever since been unvarying in ascribing to him both that work and its continuation, the Acts (q.v.) of the Apostles. With respect to the date and authorship of the last mentioned book, all that can be said here is that the majority of modern critics are of opinion that it cannot have been written by a companion of St Paul. When compared with the genuine epistles of that apostle, it exhibits many important discrepancies in detail; of these the most striking perhaps are those which are seen when Acts xv. and Gal. ii. are carefully read together. The author of the Acts, however, had access to a variety of written, as well as oral, sources of information, and to the former class belonged the document the presence of which can still be distinguished in his narrative by the use of the pronoun 'we.' There is good reason to believe that Luke is the companion of St Paul who here speaks in the first person, and, this being so, it is

not difficult to understand the process by which the authorship of the whole work ultimately came to be attributed to him. As regards the third gospel it is to be observed that its author in his preface expressly disclaims to have been an eye-witness of any of the events he records, and does not make the least pretension to any special apostolic sanction or authority. He is frankly a compiler, working after a considerable accumulation of literary material has taken place; who hopes to excel those who have gone before him in fullness of matter, accuracy of detail, comprehensiveness of scheme, and orderliness of method. That, if not himself a Gentile, he writes chiefly for Gentile readers is evident from such circumstances as the manner in which he habitually makes use of the Septuagint translation, his abstinence from Aramaisms, his referring to localities always by their Greek names, and the like. Amongst the documents employed by him the most important were the collection of 'logia,' or discourses and sayings of the Lord by Matthew, and some form of the gospel according to Mark (see GOSPELS). He must have had other sources for the details he has handed down regarding the nativity, and for the canticles which he alone has preserved. Working as he did, most probably in Rome, it was natural that he should reflect in his gospel much of the teaching of St Paul; the fact that he did so is indicated in the tradition (Eusebius) according to which that apostle alluded to the work of Luke in the expression, 'My gospel.' As regards date, the third gospel must be placed at least later than the destruction of Jerusalem (Luke, xxi. 20, 24; xix. 43, 44), and also in all probability some years later than the gospel according to Matthew.

See the commentaries of Lange, Meyer, Keil, P. Campbell (1892), and Plummer (1897); and GOSPELS.

Lukuga, an intermittent outflow from Lake Tanganyika (q.v.) into the Congo.

Lulea, the capital of the Swedish county of Norbotten, is situated at the mouth of the river Luleå, on the north-west coast of the Gulf of Bothnia. It exports timber, tar, salmon, reindeer-bides, and the produce of the Gellivara iron-mines (situated 126 miles N.W. from Lulea). In October 1888 a beginning was made with the construction of the northernmost railway in Europe (304 miles long), to run from Luleå north-westwards along the north of Sweden and Norway to Ofoten Fjord in the north of the latter country. Pop. 3392.

Lully, GIOVANNI BATTISTA, musical composer, was a Florentine by birth, born in 1633. Taken to Paris whilst still a boy, he attracted the attention of Louis XIV. by his violin-playing. The king made him director of the royal orchestra, and eventually (1672) director of operatic affairs in Paris. In collaboration with Quinault, Lully composed a great number of operas, some of which kept the stage until the time of Gluck (*circa* 1778). It was by making the ballet an essential part of the opera that Lully achieved this success. The favourites amongst his operas were *Thésée*, *Armide*, *Phaëton*, *Atys*, *Isis*, and *Acis et Galatée*. He died at Paris on 23d March 1687. A friend of Molière, he composed music for some of his comedies. See OPERA; and Rude's great monograph (1891).

Lully, RAYMOND, 'the enlightened doctor,' was born at Palma, in Majorca, in 1234. In his youth he led a dissolute life, and served for some time as a common soldier; but, a complete revulsion of feeling taking place, he withdrew to solitude, and gave himself up to ecstatic meditations and the study of the occult sciences. This sudden change of life produced in Lully a fervid and enthusiastic state of mind, under the influence of which he formed the project of a spiritual crusade

for the conversion of the Mussulmans, an idea he never afterwards abandoned. In pursuance of this project he commenced an earnest study of theology, philosophy, and the Arabic language, and after some years published his great work, *Ars Generalis sive Magna*, which has so severely tested the sagacity of commentators. This work is the development of the method of teaching known subsequently as the 'Lullian method': a mechanical aid to the mind in the acquisition of knowledge and the solution of all possible problems by a systematic manipulation of certain fundamental notions (the Aristotelian categories, &c.). He even invented a machine (of tin or pasteboard) to assist in this great task. Yet in this departure from scholastic logic, and his zeal for a true interpretation of nature, he was really a precursor of Bacon.

Lully subsequently published another remarkable work, *Libri XII. Principiorum Philosoph. contra Averroistas*, and, full of the principles which he had developed in this book, he went to Tunis in 1292 to argue with his Mohammedan opponents. Ere long he was thrown into prison and condemned to banishment. After lecturing at Naples for several years he proceeded to Rome, thence to his native island of Majorca, thence to Cyprus and Armenia. In 1306 he again sailed for Africa, entered the city of Bugia, now Bougie (q.v.), in Algeria, was again thrown into prison, and again banished. At Paris he lectured against the principles of Averroes. But his missionary zeal could only be satiated by martyrdom. Sailing once more for Africa, at Bugia he was stoned and ill-treated so that he expired a few days afterwards on board a Genoese vessel (1315). The Lullists combined a religious mysticism with a belief in alchemy.

See Helfferich, *Raymond Lull* (1858); Canalezas, *Las Doctrinas de R. Lullo* (Madrid, 1870); and the editions of his works by Salzing (Mainz, 1742) and Rossello (Palma, 1886 *et seq.*).

Lumbago is a rheumatic affection of the muscles or fibrous tissues in the lumbar region, or small of the back. It is often first recognised by the occurrence of a sharp stabbing pain in the loins upon attempting to rise from the recumbent or sitting position. It is sometimes so severe as to confine the patient to bed and in one position, from which he cannot move without intense suffering; but in milder cases he can walk, although stiffly and with pain, and usually with the body bent more or less forward. It may be distinguished from inflammation of the kidneys by the absence of the peculiar direction of the pain towards the groin, as also by the absence of the nausea and vomiting and other constitutional symptoms which usually accompany the disease of the kidney.

The causes of lumbago are the same as those of sub-acute rheumatism generally. The complaint may arise from partial exposure to cold, especially when the body is heated, and violent straining will sometimes induce it. In persons with a strong constitutional tendency to rheumatism the slightest exciting cause will bring on an attack of lumbago.

The treatment must vary with the intensity of the affection. In most cases a warm bath at bedtime, followed by ten grains of Dover's powder, or full doses of alkaline remedies, as citrate of potassium, will speedily remove it; and, as local remedies, a mustard poultice, a mixture of chloroform and soap-liniment, or the application of the heated hammer made for the purpose will be found serviceable. (See also the treatment for RHEUMATISM.) The disorder has been known to completely disappear after one application of the hammer, which should be heated in a spirit-lamp to somewhere about 200°, and then be rapidly brought in contact with points of the skin over the painful parts at intervals of about half an

inch. Each application leaves a red spot, but blisters seldom occur if the operation is properly performed. The application of a hot iron, used just as in ironing clothes, with two or three folds of blanket between it and the skin, frequently gives great relief.

Lumber. See TIMBER.

Luminosity. See LIGHT, PHOSPHORESCENCE, PHOTOMETRY.

Luminous Paint, a phosphorescent powder, such as sulphide or oxysulphide of calcium, ground up with a colourless varnish or other medium, and used as a paint. Even after daylight is over the Phosphorescence (q.v.) goes on, and the object painted remains visible in the dark. See Balmain's British patent, No. 4152 (1877).

Lumpsucker, or LUMFISH (*Cyclopterus*), a genus of fishes of the family Discoboli, having the head and body deep, thick, and short, the back with an elevated ridge, which contains within it the anterior dorsal fin, the skin without scales, but with rows of rough bony tubercles, the fins rather small, and the ventrals united by a membrane so as to form a sucking disc.—One species (*C. lumpus*) is common on the coasts of Britain, particularly in the northern parts, and is still more plentiful in the

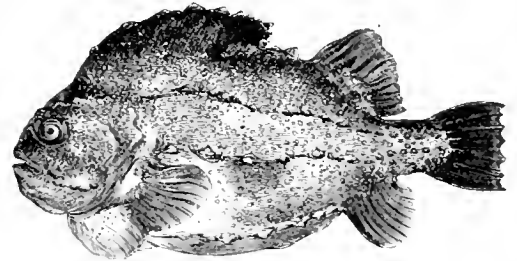

Lumpsucker (*Cyclopterus lumpus*).

seas of more northern regions. It is frequently, especially in spring, taken in large numbers in salmon stake-nets. It has a grotesque and clumsy form, but its colours are very fine, especially those of the male, combining various shades of blue, purple, and rich orange. It attains a pretty large size, sometimes weighing seven pounds. The lumpsucker preys on smaller fishes. Its sucker is so powerful that a pail containing some gallons of water has been lifted when a lumpsucker contained in it was taken by the tail. It deposits large adhesive ova which stick together in large masses attached to stones or piles near low-water mark; they are guarded during development by the male. The young are without the tubercles and resemble tadpoles; they have the ventral sucker even when first hatched. It breeds in spring. Its flesh is insipid at some seasons, but very fine at others, and is much used for food in northern regions. It is known in Scotland as the *Cock-paiddle*, probably from the resemblance of its dorsal ridge to a cock's comb; the female, which is larger than the male, is usually distinguished as the *hen-paiddle*.

Lunacy. See INSANITY.

Lunar Caustic. See CAUSTIC.

Lunar Theory, a term employed to denote the *a priori* deduction of the moon's motions from the principles of gravitation. See MOON.

Lunawara, a small state of India, under British protection, in the province of Gujarat, has an area of 388 sq. m. and a pop. of 75,450. The region is hilly, stony, and well wooded. The capital, from which the state derives its name, is

60 miles N. by W. from Baroda, near the Mahi River. Pop. 9059.

Lund (*Lundinum Gothorum*), a city of Gothland, in the extreme south of Sweden, by rail 374 miles SW. of Stockholm and 10 NE. of Malmo. In the 10th century it was a large and powerful city, was made a bishopric in 1048, and an archbishopric in 1104. The archbishop claimed ecclesiastical supremacy over the whole of Scandinavia. At the same period Lund was the chief seat of the Danish power in the Scandinavian peninsula, and for a long period the capital of the Danish kingdom; at the epoch of its greatest prosperity it is said to have had 200,000 inhabitants. But after the introduction of the Reformation by Christian III. in 1536, the city began to decay, and had sunk down to a mere village before the end of the 17th century. The principal building is the fine Romanesque cathedral, dating from the 11th century; it has an imposing crypt. Lund owes its revival to the founding there of a university in 1668 by Charles XI. It is now attended by about 800 students, and has a library of 120,000 volumes and 3000 MSS., an excellent zoological museum, and a botanic garden. Tegner was a professor from 1813 to 1826, and here he composed his masterpiece, *Erdljof*. Pop. (1885) 14,835.

Lundy (Scand., 'grove island'), a granitic island of Devonshire, in the mouth of the Bristol Channel, 11½ miles NNW. of Hartland Point, 17 NW. of Clovelly, 24 W. of Hiracombe, and 30 SSE. of St Gowan's Head in Wales. It measures 3½ miles by 1; has rocky and precipitous shores, with only one landing-place on the south side; and attains an altitude of 525 feet. Here, near the southern end of the island, is a lighthouse, built in 1820. The cliffs are the resort of multitudes of sea-fowl. The antiquities include prehistoric kists, remains of round towers and a chapel, and the ruined castle of the Mariscoes (11th to 14th centuries), from whose time on into the 17th century Lundy was a stronghold successively of pirates, buccaneers, privateers, and smugglers. It figures in Kingsley's *Westward Ho!*; was the death-place of 'Judas' Stukely; was garrisoned till 1647 for Charles I.; and in 1834 was purchased for £9870 by the Heaven family. Pop. (1851) 34; (1881) 177; (1891) 53. See Chanter's *Lundy Island* (1877).

Lüneburg, a town of Hanover, situated on the river Ilmenau, 31 miles by rail SE. of Hamburg. Its streets are narrow and its houses medieval, but its suburbs are modern. The 15th century church of St Michael contains the tombs of the Lüneburg princes. The five-aisled church of St John dates from the 14th century, is pure Gothic in style, and has a tower 371 feet high. The medieval town-house is adorned with old pictures and stained glass. A salt mine, discovered in 906, still has an annual yield of 21,250 tons. There are also a gypsum-mine, iron-works, chemical manufactories, &c. Lüneburg lampreys are well known in Germany. Pop. (1885) 19,336. Although existent in 795, the place only began to acquire importance after the founding of the Benedictine monastery in 994; it was greatly increased by the settlement here of large numbers of the people of Bardowick, destroyed in 1189. Lüneburg afterwards joined the Hanseatic League, and was the capital of an independent duchy. But it lost the greater part of its privileges in the 16th century, and in the 17th suffered much from the Swedes and their enemies. It began to revive again in the 19th century. Near by the Allies defeated the French on 21 April 1813.

The principality of Lüneburg, or rather Brunswick-Lüneburg, existed from 1235 to 1369, from 1373 to 1532, and from 1546 onwards. From the

princes of this house is descended the reigning house in Great Britain (see BRUNSWICK). South of Lüneburg stretches for 50 miles on end the Lüneburg Moor (*Heide*), a grazing-ground for sheep. It produces also honey, buckwheat, and numerous wild berries, and is largely clothed with fine heather. See History by Jürgens (1891).

Lunel, a town in the south of France, 14 miles by rail NE. of Montpellier, with a trade in Muscatel wine and brandy. Interesting human remains have been found in a cave at Pondres, 6 miles N. of Lunel. Pop. 6460.

Lunette. See FORTIFICATION.

Lunéville, a town in the French department of Meurthe-et-Moselle, at the confluence of the Meurthe and the Vezouse, and 20 miles by rail SE. of Nancy. It was formerly a residence of the Dukes of Lorraine; their palace, built by Duke Leopold, in which the Emperor Francis I. was born, is now used as a cavalry barrack, this town being one of the largest cavalry stations in France. Here was signed the peace of Lunéville, on February 9, 1801, between Germany and France, on the basis of the peace of Campo-Formio (q.v.). The industry embraces gloves, hosiery, cottons, &c. Pop. (1872) 12,251; (1886) 20,114.

Lungs. See RESPIRATION (ORGANS OF); and for diseases of the lungs, the articles on CONSUMPTION, PNEUMONIA, PLEURISY, &c.

Lungwort, or OAK-LUNGS (*Stictis pulmonaria*), a lichen with a foliaceous, leathery, spreading thallus, of an olive-green colour, pale brown when dry, pitted with numerous little cavities and netted, much lacinated; the shields (*apothecia*) marginal, reddish brown with a thick border. It grows on trunks of trees in mountainous regions, in Britain and other European countries, sometimes almost entirely covering them with its shaggy thallus. It has been used as a remedy for pulmonary diseases. It is nutritious, and, when properly prepared, affords a light diet, capable of being used as a substitute for Iceland moss; yet it is bitter enough to be used as a substitute for hops. It yields a good brown dye.—The name lungwort is also given to a genus of planerogamous plants (*Pulmonaria*) of the natural order Boraginæ. The common lungwort (*P. officinalis*) is a rare and rather doubtful native of Britain, although common in some parts of Europe. It has ovate leaves and purple flowers, and was formerly employed in diseases of the lungs, but seems to have been recommended chiefly by a fancied resemblance to the lungs in its spotted leaves. It is mucilaginous and contains nitre. It has been used as a pot-herb.

Lunkah, better LANKA, Sansk. 'island,' is specially used of Ceylon, and also of a great tobacco-growing district in the delta of the Godavari.

Lupercalia, a festival among the ancient Romans, held on the 15th of February, in honour of Lupercus, the god of fertility. When Rome began to seek a Grecian origin for its religious ceremonies Lupercus was identified with Lycean Pan, and his worship was said to have been introduced by Evander, the Arcadian. Modern scholars place no value on such statements. Lupercus is believed by them to have been one of the oldest pastoral deities of Italy, and everything that is known regarding him and his rites favours this view. These rites were of the rudest and most primitive character, and indicate a high antiquity. Goats and dogs were sacrificed; afterwards the priests (called *Luperci*) cut up the skins of the victims, and twisted them into thongs, with which they ran through the city striking every one they met, especially women, who put themselves in their

way hoping that the god of fertility would be propitious towards them. As the festival is believed to have been at first a shepherd one, this running about with thongs is understood to have been intended as a symbolical purification of the land. The place where the festival was held was called the Lupercal, and was situated on the Palatine Hill. It contained an image of Luperus, covered with a goat's skin. Lupercalia were also held in other cities of Italy.

Lupine (*Lupinus*), a genus of plants of the natural order Leguminosae, sub-order Papilionaceae, mostly annuals, but some of them perennial herbaceous plants, some half-shrubby; and generally having digitate leaves, with rather long stalks. The flowers are in racemes or spikes, the calyx two-lipped, the keel beaked, the filaments all united at the base. The species of lupine are numerous, and are chiefly natives of the countries near the Mediterranean Sea, and of the temperate parts of North and South America. The White Lupine (*L. albus*), a species with white flowers, has been cultivated from time immemorial in the south of Europe and in some parts of Asia, for the sake of the seeds, which are farinaceous and are used as food, although when raw they have a strong, disagreeable, bitter taste, which is removed by steeping in water and boiling. They were a favourite kind of pulse amongst the ancient Greeks and Romans, and still are so in some parts of the south of Europe, although generally disliked by those who have not been accustomed to them. The Yellow Lupine (*L. luteus*), so called from its yellow flowers, and the Egyptian White Lupine (*L. Theriacis*), which has white flowers tipped with blue, are also cultivated in the south of Europe, Egypt, &c. for their seeds, which are similar in their qualities to those of the white lupine. In many countries lupines, and particularly the white lupine, are cultivated to yield green food for cattle, and also to be ploughed down for manure. They grow well on poor and dry sandy soils, which by this process of *green-manuring* are fitted for other crops. Many species of lupine are cultivated in our flower-gardens, having beautiful white, yellow, pink, or blue flowers. The flowers of some species are fragrant. No lupine is a native of Britain. *L. perennis* adorns sandy places from Canada to Florida with its fine blue flowers.

Lupton, THOMAS G. (1791-1873). See ENGRAVING, Vol. IV, p. 381.

Lupuline. See HORS.

Lupus is a chronic disease of the skin, in which dull or livid tubercles are developed, having a tendency to destroy or so seriously to affect the adjacent tissues, with or without ulceration, as always to lead to indelible cicatrices. It was formerly known as *vulvæ lupus*. The disease usually attacks the face, especially the ale of the nose and the lips, but may occur on almost any part of the body. It usually begins in childhood or early adult life, but may recur at a later period. It more often affects the female sex, and is not contagious, nor usually hereditary. It is, in its severer forms, a terrible disease, but is happily of somewhat rare occurrence. It derives its name from the Latin *lupus*, 'wolf,' in consequence of its destructive nature. See TUBERCLE.

Lupus usually commences with the appearance of one or two circular or oval, dull-red, somewhat translucent tubercles, about two lines in diameter. After a time these tubercles increase in number and size, and take on new characters. They may ulcerate, constituting the variety known as *Lupus cecidens*, in which case the ulceration may pursue a superficial or a deep course. Scabs are formed over the ulcers; and as these scabs are thrown off

the ulcer beneath is found to have increased in extent, till great destruction of the soft parts and (in the case of the nose) of the cartilages is effected. The ulcer of lupus has thick red edges, and exudes a fetid, ichorous matter in considerable quantity. When they do not ulcerate, the tubercles are softer than in the previous variety, and form patches of considerable extent, the intervening skin and cellular tissue also swelling and exhibiting here and there dull-red points, which are the summits of the imbedded tubercles. The lips become much enlarged, the nostrils closed with the swelling, the eyelids everted, and the whole face hideous. This variety is known as *Lupus non cecidens*.

The progress of lupus is usually slow, and the sufferings of the patient less than might be expected, in consequence of the sensibility of the parts being diminished from the first. The complaint may continue for years, or even for life, but is seldom fatal. Its causes are not well known; it is thought that a scrofulous habit predisposes to the disease, but in many of those affected the health is otherwise excellent. A bacillus has been found in the diseased tissues, never abundantly, which is indistinguishable from the tubercle bacillus; but lupus is so rarely associated with tuberculous disease elsewhere that it is doubtful whether the two organisms are actually identical.

Treatment.—It is of course desirable that the patient's general health be brought into as vigorous a condition as possible; and for this purpose cod-liver oil, iodide of iron, and other tonics are often useful. But no internal remedy seems to have any reliable effect upon the disease. The local treatment has passed through many variations: the application of strong escharotics, repeated incisions, or scraping away of the diseased tissues, were often successful in modifying or arresting the disease. Less severe measures, however, first recommended in 1886 by Uma of Hamburg, have proved very efficacious. Chief among these is the constant application to the diseased parts of plasters made for the purpose, containing salicylic acid, which, while it has little effect upon the healthy skin, causes gradual breaking down and removal of the diseased tissues, and creasote, which greatly diminishes the pain caused by salicylic acid alone. Under any method of treatment, however, the disease is apt to be obstinate and troublesome.

Luray Cavern, a cave, not large, but remarkable for the vast number and extraordinary shapes of its stalactites, is close to Luray village, Virginia (90 miles NW. of Richmond). Many of these wonderful columns exceed 50 feet in length; numbers of them are hollow, giving out bell-like notes when struck; and the colours range from waxy white to yellow, brown, or rosy red. The cavern, which is lit with the electric light, attracts thousands of visitors every year.

Lurcher, a name applied to any dog with a distinct cross of greyhound. The commonest form of the lurcher is the first cross between the collie and the greyhound, though in some instances they have been bred for many generations without a fresh cross. As the lurcher combines to a great extent the speed of the greyhound and the sagacity of the collie, no hare is able to escape him. The owner of such an animal is an object of suspicion to every gamekeeper.

Lurgan, a thriving town of Ireland, in County Armagh, 20 miles SW. of Belfast by rail. It is but 3 miles south of the shores of Lough Neagh, and the country around is populous and fertile. It has thriving manufactures of cambrics, lawns, damasks, and diapers. Pop. (1891) 11,429.

Luristan, a mountainous province in the west of Persia. Area, 15,060 sq. m.; pop. about 300,000.

It corresponds roughly to the ancient Susiana, was the seat of the ancient Elamite empire, and is now occupied by numerous minor tribes.

Lurlei. See LORELEI.

Lusatia (*Lusitz*), a Wendish district now belonging in part to Saxony and in part to Prussia. It was formerly divided into Upper and Lower Lusatia, which constituted two independent margraviates, including an area of about 4400 sq. m. and a pop. of about half a million. Given in 1319 to Bohemia, and obtained by Matthias Corvinus in 1478, Lusatia was transferred to Saxony in 1635; but, by the Congress of Vienna, the whole of Lower Lusatia and the half of Upper Lusatia was ceded to Prussia. The portion left to Saxony now forms the circle of Bautzen.

Lushais, a wailike race occupying the little-known Lushai Hills in Cachar (Assam), Chittagong (Bengal), and the adjoining parts of Burma. To check their raids on British territory, expeditions have been required—in 1871-72, and again in 1889-90. Their country is now British.

Lusiads. See CAMOENS.

Lusignan, a picturesque town in the French department of Vienne, 17 miles SW. of Poitiers. It has a very fine church dating from the 11th century, but its castle, associated by legend with the fairy Melusine (q.v.), was razed by the Catholics in 1574. The House of Lusignan gave two titular kings to Jerusalem, and four kings to Cyprus. Pop. 1255.

Lusitania. See PORTUGAL.

Lustre, the characteristic appearance of a bright metallic surface, or of air within glass under water as seen under certain angles of total reflection (see REFLECTION). It is supposed to be due to the conflict between the images in the two eyes, which do not coincide in respect of brightness all over the field. A similar result may be obtained by looking with one eye at a white-and-black and with the other at a black-and-white object, the form, sizes, and positions of the objects being such as would otherwise have enabled the observer to blend them into a single stereoscopic image (see STEREOSCOPE); the opposition of brightness makes the stereoscopic binocular image assume a lustrous appearance.

Lustrum (from *laere*, 'to purify' or 'expiate'), the solemn offering made for expiation and purification by one of the censors in name of the Roman people at the conclusion of the census. The animals offered in sacrifice were a boar (*sus*), sheep (*ovis*), and bull (*taurus*), whence the offering was called *Suovetaurilia*. As the census was quinquennial, the word *lustrum* came to mean a period of five years.

Lute (Arab. *El Oul*), an obsolete stringed instrument, which three hundred years ago was as popular as is the piano to-day. It was introduced into Europe by the Arabians, from whose language it derives its name. The Arabian lute was made of twenty-one pieces of maple wood, with a flat face, a round back, and three rosettes in the face. The strings were eight in number, and were tuned in pairs. The date of its introduction and dissemination through Europe is shortly after the conquest of Spain by the Arabians. The European lute possessed originally eight strings. This number was not increased for many centuries. Three new strings were then added, bringing up the number to eleven; of these two were tuned alike, and the odd one, which was also the highest, was called chanterelle. The need of accommodating the lute to the chromatic scale procured the addition of thirteen new strings, until in the 17th century the total of twenty-four was reached, beyond which

number the augmentation did not continue. At that date the lute commonly in use in Europe consisted of a table of fir or pine; a body or belly, composed of convex ribs of pine; a neck, or finger-board, of hard wood, on which were frets, consisting of catgut strings fastened tightly round the neck; a head, on which were placed the pegs or screws that tightened or relaxed the strings in tuning; and a bridge, to which the strings were attached at one end, the other end being fastened to a piece of ivory, between the head and neck. Of the twenty-four strings twelve ran over the finger-board and twelve by the side of it. The performer used his left hand to press the frets, and struck the strings with his right. There were many varieties of the lute; the treble lute was the smallest, the bass lute the largest. The theorbo was a double-necked lute, of which the archlute and the chitarrone were two subordinate varieties. A peculiar description of notation, called *luthatur*, was employed in music written for the lute. The strings were represented by parallel lines, on which were placed letters of the alphabet, referring to the frets; thus, A marked that the string was to be struck open; B, that the first fret was to be pressed; C, the second, and so on. Over the lines were placed crotchets, quavers, &c., which denoted the lengths of the various notes. The Arabian lute is still extant in the East, of a form nearly identical with that described. The European lute survives only in the guitar and similar instruments. The lute is represented on the sculptures of the Egyptian tombs, so that the antiquity of the instrument is immense. For the European lute, see Becker's *Hausmusik in Deutschland* (1840); for the Arabian lute, Rowbotham's *History of Music*, vol. iii. (1887).

Lute (Lat. *lutum*, 'clay'), in Chemistry, denotes a substance employed for effectually closing the joints of apparatus, so as to prevent the escape of vapour or gases, or for coating glass vessels so as to render them more capable of sustaining a high temperature, or for repairing fractures.

Lutetia. See PARIS.

Luthardt, CHRISTOPH EUGST, Lutheran theologian, born at Maroldsweisach in Lower Franconia, 22d March 1823, studied at Erlangen, and became professor of Theology at Marburg in 1854, and in 1856 at Leipzig. His Commentary on John's Gospel (1852; 2d ed. 1875) has been translated into English, as has also *St John the Author of the Fourth Gospel*, and works on the saving, the fundamental, and the moral truths of Christianity (*Apokalyptische Vorlesung*). He is also author of a *Compendium der Dogmatik* (1865; 9th ed. 1893), *Die Ethik Luthers* (1867), and *Die Antike Ethik* (1887), besides collections of lectures and sermons. See his *Reminiscences* (2d ed., 1891).

Luther, MARTIN, the greatest of the Protestant Reformers of the 16th century, was born at Eisleben on the 10th November 1483. His father was a miner in humble circumstances; his mother, as Melancthon records, was a woman of exemplary virtue (*exemplar virtutum*), and peculiarly esteemed in her walk of life. Shortly after Martin's birth his parents removed to Mansfeld, where their circumstances ere long improved by industry and perseverance. Their son was sent to school; and both at home and in school his training was severe. His father sometimes whipped him, he says, 'for a mere trifle till the blood came,' and he was subjected to the scholastic rod fifteen times in one day! Luther's schooling was completed at Magdeburg and Eisenach, and at the latter place he attracted by his singing the notice of a good lady of the name of Cotta, who provided him with a comfortable home during his stay there. Here under Trebonius

he made good progress in Latin. In 1501, when he had reached his eighteenth year, he entered the university of Erfurt, with the view of qualifying himself for the legal profession. He went through the usual studies in the classics and the schoolmen, and took his degree of Doctor of Philosophy, or Master of Arts, in 1505, when he was twenty-one years of age. Ere this, however, the death of a friend, and the terror of a thunderstorm, had deeply impressed him; and he was led to the study of the Scriptures. Not content with the gospels and epistles in the lectionaries, and failing to find elsewhere a complete Bible (though the whole Vulgate had been translated into German before his time; see BIBLE, Vol. II, p. 127), he had recourse to the Vulgate in the university library. His heart was touched, and he resolved to devote himself to a spiritual life. He separated himself from his friends and fellow-students, and withdrew into the Augustinian convent at Erfurt. Here he spent the next three years of his life—years of peculiar interest and significance; for it was during this time that he laid, in the study of the Bible and of Augustine, and with the assistance of his life-long friend Staupitz, the foundation of those doctrinal convictions which were afterwards to rouse and strengthen him in his struggle against the papacy. He describes very vividly the spiritual crisis through which he passed, the burden of sin which so long lay upon him, 'too heavy to be borne,' and the relief that he at length found in the clear apprehension of the doctrine of the 'forgiveness of sins' through the grace of Christ.

In the year 1507 Luther was ordained a priest, and in the following year he removed to Wittenberg, destined to derive its chief celebrity from his name. He became a teacher in the new university founded there by the Elector Frederick of Saxony. At first he lectured on dialectics and physics, but his heart was already given to theology, and in 1509 he became a Bachelor of Theology, and commenced lecturing on the Holy Scriptures. His lectures made a great impression, and the novelty of his views already began to excite attention. 'This monk,' said the rector of the university, 'will puzzle our doctors, and bring in a new doctrine.' Besides lecturing, he began to preach, and his sermons reached a wider audience, and produced a still more powerful influence. They were printed and widely circulated in Germany, France, and England, so that the doctrines of salvation by free grace were diffused throughout Europe. His words, as Melancthon said, were 'born not on his lips, but in his soul,' and they moved profoundly the souls of all who heard them. In 1511 he was sent on a mission to Rome, and he has described very vividly what he saw and heard there. His devout and unquestioning reverence—for he was yet in his own subsequent view 'a most insane papist'—appears in strange conflict with his awakened thoughtfulness and the moral indignation at the abuses of the papacy beginning to stir in him. It was when climbing on his knees the steps of the so-called judgment-seat of Pilate that the words, 'the just shall live by faith,' flashed upon his soul and drove him to his feet.

On Luther's return from Rome he was made a Doctor of the Holy Scriptures, and his career as a Reformer may be said to have commenced. The system of indulgences had reached a scandalous height. The idea that it was in the power of the church to forgive sin had gradually grown into the notion that the pope could issue pardons of his own free will, which, being dispensed to the faithful, exonerated them from the consequences of their transgressions (see INDULGENCE). The sale of these pardons had become an organised part of the papal system. Money was largely

needed at Rome to feed the extravagances of the papal court; and its numerous emissaries sought everywhere to raise funds by the sale of 'indulgences'; the principal of these was John Tetzel, a Dominican friar, who had established himself at Jüterbog (1517). Luther's indignation at the shameless traffic which this man carried on finally became irrepressible: 'God willing,' he exclaimed, 'I will beat a hole in his drum.' He drew out ninety-five theses on the doctrine of indulgences, which on 31st October he nailed up on the door of the church at Wittenberg, and which he offered to maintain in the university against all impugners. The general purport of these theses was to deny to the pope all right to forgive sins. This sudden and bold step of Luther was all that was necessary to awaken a widespread excitement. Tetzel was forced to retreat from the borders of Saxony to Frankfort-on-the-Oder, where he drew out and published a set of counter-theses, and publicly committed those of Luther to the flames. The students at Wittenberg retaliated by burning Tetzel's theses. The elector refused to interfere, and the excitement increased as new combatants—Hochstratten, Prierias, and Eck—entered the field. Eck was an able man, and an old friend of Luther's, and the argument between him and the Reformer was especially vehement. In 1518 the latter was joined by Melancthon, who became one of his dearest and most trusted friends.

At first the pope, Leo X., took little heed of the disturbance; he is reported even to have said when he heard of it that 'Friar Martin was a man of genius, and that he did not wish to have him molested.' Some of the cardinals, however, saw the real character of the movement, which gradually assumed a seriousness evident even to the pope; and Luther received a summons to appear at Rome, and answer for his theses (1518). Once again in Rome it is unlikely he would ever have been allowed to return. His university and the elector interfered, and a legate was sent to Germany to hear and determine the case. Cardinal Cajetan was the legate, and he was but little fitted to deal with Luther. He would enter into no argument with him, but merely called upon him to retract. Luther refused, and fled from Augsburg, whither he had gone to meet the papal representative. The task of negotiation was then undertaken by Miltitz, a German, who was envoy of the pope to the Saxon court, and by his greater address a temporary peace was obtained. This did not last long. The Reformer was too deeply moved to keep silent. 'God hurries and drives me,' he said; 'I am not master of myself; I wish to be quiet, and am hurried into the midst of tumults.' Dr Eck and he held a memorable disputation at Leipzig (1519), in which the subject of argument was no longer merely the question of indulgences, but the general power of the pope. The disputation, of course, came to no practical result; each controversialist claimed the victory, and Luther in the meantime made progress in freedom of opinion, and attacked the papal system as a whole more boldly. Erasmus and Hutten joined in the conflict, which waxed more loud and threatening.

In 1520 the Reformer published his famous address to the 'Christian Nobles of Germany.' This was followed in the same year by a treatise *On the Babylonish Captivity of the Church*. In these works, both of which circulated widely, and powerfully influenced many minds, Luther took firmer and broader ground; he attacked not only the abuses of the papacy and its pretensions to supremacy, but also the doctrinal system of the Church of Rome. 'These works,' Ranke says, 'contain the kernel of the whole Reformation.' The papal bull containing forty-one theses was

issued against him; the dread document, with other papal books, was burned before an assembled multitude of doctors, students, and citizens at the Elster Gate of Wittenberg. Germany was convulsed with excitement. Eck (who had been the chief agent in obtaining the bull) fled from place to place, glad to escape with his life, and Luther was everywhere the hero of the hour. Charles V. had at this time succeeded to the empire, and he conveyed his first diet of the sovereigns and states at Worms. The diet met in the beginning of 1521; an order was issued for the destruction of Luther's books, and he himself was summoned to appear before the diet. This was above all what he desired—to confess the truth before the assembled powers of Germany. He resolved—having received a safe conduct—to obey the summons, come what would. All Germany was moved by his heroism; his journey resembled a triumph; the threats of enemies and the anxieties of friends alike failed to move him. 'I am resolved to enter Worms,' he said, 'although as many devils should set at me as there are tiles on the house-tops.' His appearance and demeanour before the diet, and the firmness with which he held his ground and refused to retract, all make a striking picture. He was not allowed to defend his opinions. 'Unless I be convinced,' he said, 'by Scripture and reason, I neither can nor dare retract anything, for my conscience is a captive to God's word, and it is neither safe nor right to go against conscience. There I take my stand, I can do no otherwise. So help me God. Amen.'

On his return from Worms he was seized, at the instigation of his friend, the Elector of Saxony, and safely lodged in the old castle of the Wartburg. The affair was made to assume an aspect of violence, but in reality it was designed to secure him from the destruction which his conduct at Worms would certainly have provoked, he having been placed under the ban of the empire. He remained in this shelter for about a year, concealed in the guise of a knight. His chief employment was his translation of the Scriptures into his native language. He composed various treatises besides, and injured his health by sedentary habits and hard study. His imagination became morbidly excited, and he thought he saw and heard the Evil One mocking him while engaged in his literary tasks: the blot from the inkstand that he hurled at him is still shown on the wall of his chamber. The subject of the personality and presence of Satan was a familiar one with Luther, and he has many things about it in his *Table-talk*.

The disorders which sprang up in the progress of the Reformation recalled Luther to Wittenberg. He felt that his presence was necessary to restrain Carlstadt and others, and, defying any danger to which he might still be exposed, he returned in 1522 to the old scene of his labours, rebuked the unruly spirits who had acquired power in his absence, and resumed with renewed energy his interrupted work. He strove to arrest the excesses of the Zwickian fanatics, and counselled peace and order to the inflamed peasants, while he warned the princes and nobles of the unchristian cruelty of many of their doings, which had driven the people to exasperation and frenzy. At no period of his life is he greater than now in the stand which he made against lawlessness on the one hand and tyranny on the other. He vindicated his claim to be a Reformer in the highest sense by the wise and manly part which he acted in this great social crisis in the history of Germany. In this year also he published his acrimonious reply to Henry VIII. on the seven sacraments. Although he had been at first united in a common cause with Erasmus, estrangement had gradually sprung up between the

scholar of Rotterdam and the enthusiastic Reformer of Wittenberg. This estrangement came to an open breach in the year 1525, when Erasmus published his treatise *De Libero Arbitrio*. Luther immediately followed with his counter-treatise, *De Servo Arbitrio*. The controversy raged loudly between them; and in the vehemence of his hostility to the doctrine of Erasmus Luther was led into various assertions of a very questionable kind, besides indulging in wild abuse of his opponent's character. The quarrel was an unhappy one on both sides; and it must be confessed there is especially a want of generosity in the manner in which Luther continued to cherish the dislike which sprang out of it. In the course of the same year Luther married Katharina von Bora, one of nine nuns who, under the influence of his teaching, had emancipated themselves from their religious vows. The step rejoiced his enemies, and even alarmed some of his friends like Melancthon. But it greatly contributed to his happiness, while it served to enrich and strengthen his character. All the most interesting and touching glimpses we get of him henceforth are in connection with his wife and children.

Two years after his marriage he fell into a dangerous sickness and depression of spirits, from which he was only aroused by the dangers besetting Christendom from the advance of the Turks. Two years later, in 1529, he engaged in his famous conference at Marburg with Zwingli and other Swiss divines. In this conference he obstinately maintained his peculiar views as to the sacrament of the Lord's Supper (q.v.), and, as in the controversy with Erasmus, distinguished himself more by the inflexible dogmatism of his opinions than by the candour and comprehensiveness of his arguments, or the fairness and generosity of his temper. Aggressive and reforming in the first stage of his life, and while he was dealing with practical abuses, he was yet in many respects essentially conservative in his intellectual character, and he shut his mind pertinaciously after middle life to any advance in doctrinal opinion. The following year finds him at Coburg, while the diet sat at Augsburg. It was deemed prudent to entrust the interests of the Protestant cause to Melancthon, who attended the diet, but Luther removed to Coburg, to be at hand for consultation. The drawing up of the Augsburg Confession (q.v.) marks the culmination of the German Reformation (1530); and the life of Luther from henceforth possesses comparatively little interest. He survived sixteen years longer, but they are years marked by few incidents of importance. He died at Eisleben on 18th February 1546, and was buried at Wittenberg.

Luther's character presents an imposing combination of great qualities. Endowed with broad human sympathies, massive energy, manly and affectionate simplicity, and rich, if sometimes coarse humour, he is at the same time a spiritual genius. His intuitions of divine truth were bold, vivid, and penetrating, if not comprehensive; and he possessed the art which God alone gives to the finer and abler spirits that He calls to do special work in this world, of kindling other souls with the fire of his own convictions, and awakening them to a higher consciousness of religion and duty. He was a leader of men, therefore, and a Reformer in the highest sense. His powers were fitted to his appointed task: it was a task of Titanic magnitude, and he was a Titan in intellectual robustness and moral strength and courage. It was only the divine energy which swayed him, and of which he recognised himself the organ, that could have accomplished what he did.

View him as a mere theologian, and there are

others who take higher rank. There is a lack of patient thoughtfulness and philosophical temper in his doctrinal discussions; but the absence of these very qualities gave vigour to his hold, if sometimes crude conceptions, and enabled him to triumph in the struggle for life or death in which he was engaged. To initiate the religious movement which was destined to renew the face of Europe, and give a nobler and more enduring life to the Teutonic nations, required a gigantic will, which, instead of being crushed by opposition, or frightened by hatred, should only gather strength from the fierceness of the conflict before it. To clear the air thoroughly, as he himself said, thunder and lightning are necessary. Upon the whole, it may be said that history presents few greater characters—few that excite at once more love and admiration, and in which we see tenderness, humour, and a certain picturesque grace and poetic sensibility more happily combined with a lofty and magnanimous, if sometimes rugged sublimity.

Luther's works are very voluminous, partly in Latin, and partly in German. Among those of more general interest are his *Table-talk*, his *Letters*, and *Sermons*. His Commentaries on Galatians and the Psalms are still read; and he was one of the great leaders of sacred song, his hymns, rugged, but intense and expressive, having an enduring power.

The most important complete editions of Luther's works are those of Wittenberg (12 vols. German; 8 vols. Latin, 1539-58); Halle, ed. by Walch (German, 24 vols. 1740-53); and Erlangen and Frankfurt (67 vols. German; 33 vols. Latin, 1826-73). A splendid new and complete edition was commenced at Weimar in the year of the fourth centenary of his birth (1883).

His *Briefe, Sendschreiben und Gedanken* were edited by De Wette and Seidenmann (6 vols. 1825-56); the *Briefwechsel*, by Burkhardt (1866); and by Enders (1884 *et seq.*); his *Politische Schriften*, by Mundt (1844); his *Kirchenpostille*, by Francke (1841); his *Tischreden*, by Forstmann and Bindsil (1846-48); his *Geistliche Lieder*, by Wackernagel (1856), Godeke (1883), and A. Fischer (1883). A good selection of the lesser writings is that entitled *Martin Luther als Deutscher Klassiker* (3 vols. Frank. 1871-83).

Of the many Lives the most important are those of Meurer (3d ed. 1870), Jurgens (3 vols. 1846-47), Kostlin (2 vols. 1875; 3d ed. 1883; also a popular ed. 1883), Plitt and Petersen (2d ed. 1883), and Kolbe (1884 *et seq.*). There is an English life of merit by Peter Bayne (1887), and well-known essays by Carlyle, Froude, Tulloch, and others. See also Dr Charles Beard's admirable book, *Martin Luther and his Reformation in Germany until the Close of the Diet of Worms* (1889).

On Luther's theology there are works by Th. Harnack (1862-86), Kostlin (1863), and Lommatsch (1879). The Catholic view is fairly given by Dollinger, and in Janssen's *Geschichte des Deutschen Volkes*.

Lutherans, a designation originally applied by their adversaries to the Reformers of the 16th century, and afterwards distinctively appropriated among Protestants themselves to those who took part with Martin Luther against the Swiss Reformers, particularly in the controversies regarding the Lord's Supper. It is so employed to this day as the designation of one of the two great sections into which the Protestant Church was soon unhappily divided, the other being known as the Reformed Church (q.v.). To the end of Luther's life perfect harmony subsisted between him and his friend Melancthon; but already there were some who stood forth as more Lutheran than Luther, and by whom Melancthon was denounced as a 'crypto Calvinist' and a traitor to evangelical truth. After Luther's death this party became more confident, and, holding by Luther's words, without having imbibed his spirit, changed his evangelical doctrine into a dry scholasticism and

lifeless orthodoxy, whilst extreme heat and violence against their opponents were substituted in the pulpit itself for the zealous preaching of the gospel. The principal seat of their strength was in the university of Jena, which was founded in 1557 for this very object, and maintained their cause against Wittenberg. Great intolerance was manifested by this party; and no controversy was ever conducted with more bitterness than the Sacramentarian Controversy.

Towards the end of the 17th century the Lutherans of Germany found a new object of hostility in the Pietists (q.v.); and in the 18th century they came into conflict with Rationalism (q.v.). When, after the wars of the French Revolution were over, the Prussian government formed and carried into execution a scheme for the union of the Lutheran and Reformed churches into one national church, leaving them free to use either the Lutheran or Heidelberg confession, an active opposition arose on the part of those who now began to be known as *Old Lutherans*. Separate congregations were formed, and an attitude of open hostility to the government was assumed by some; whilst others, more moderate, but holding the same theological opinions, continued to maintain these opinions within the *United Evangelical Church*. The separatists were for some time severely dealt with by the government, and about 1837 many left their native country to found Old Lutheran communities in America. After that time greater toleration was practised, and in 1841 the Old Lutherans became a legally-recognised ecclesiastical body in Prussia. A freer *New Lutheranism*, claiming to represent Luther's spirit rather than the dogmas of the old Lutheran systematists, has since 1848 become practically dominant in most parts of Protestant Germany, in Prussia as well as elsewhere, under the leadership of such men as Hengstenberg, Hofmann, Harless, Luthardt, Thomasius, and Kahnis.

Lutheranism is the prevailing form of Protestantism in Germany; it is the national religion of Denmark, Sweden, and Norway; and there are Lutheran churches in the Baltic provinces of Russia, in Holland, France, Poland, and the United States—in which latter country there were in 1890 as many as 7911 churches, with 1,086,048 members. In all there are some thirty millions of Lutherans. Amongst the Lutheran symbolical books the *Augsburg Confession* (q.v.), Luther's *Shorter Catechism*, and the *Formula Concordiæ* (see CONFESSIONS) hold the principal place. The chief difference between the Lutherans and the Reformed is as to the *real presence* of Christ in the sacrament of the Supper; the Lutherans holding the doctrine of *consubstantiation*—Christ's body present 'in, with, and under the unchanged bread and wine'—although rejecting *transubstantiation* (see LORD'S SUPPER; TRANSUBSTANTIATION; and ZWINGLI); whilst some of their more extreme theologians have asserted not only the presence of the human nature of Christ in the Lord's Supper, as Luther did, but the absolute omnipresence or ubiquity of his human nature. Other points of difference relate to the allowance in Christian worship of things *indifferent* (*adiaphora*); and many of those things at first retained as merely tolerable by Luther and his fellow-reformers have become favourite characteristics of some of the Lutheran churches—as crucifixes and pictures in places of worship, &c.

In its constitution the Lutheran Church is generally *episcopopal*, without being properly *presbyterian*. It is consistorial (see CONSISTORY), with the civil authorities so far in place of bishops. In Denmark, Sweden, and Norway there

are bishops, and in Sweden an archbishop (of Upsala), but their powers are very limited.

See the works of the old systematists Chemnitz, Johann Gerhard, Hutter, Quenstedt; Hase's *Hutterus Redivivus* (1828; 12th ed. 1883); the dogmatical works of Twisten, Nitzsch, and Martensen; and the church histories.

Luton, a market-town of Bedfordshire, on the little Lea, among the Chiltern Hills, 31 miles by rail NNW. of London. St Mary's Church, mixed Decorated and Perpendicular in style, is a noble structure, with a flint-work tower 90 feet high, a baptistery chapel, and many interesting monuments. It has been restored since 1865. Luton is the chief seat in England of the straw-plait (for hats, bonnets, &c.), an industry which dates from the reign of James I., and employs 20,000 persons here and in the neighbourhood. The Plait-hall (1869) is a fine building; and there are also a town-hall, corn exchange, people's park, &c. Luton was re-incorporated as a municipal borough in 1876. Pop. (1851) 10,648; (1891) 30,006. See F. Davis, *History of Luton* (1855).

Lutterworth, a small town of Leicestershire, on the Swift, 8 miles NNE. of Rugby. The fine old church, restored by Scott in 1867-69, contains the pulpit and other relics of Wyclif, who was rector from 1374 till his death on 28th December 1384. He was buried here, but in 1428 his remains were dug up and burned, and the ashes cast into the Swift. 'This brook conveyed his ashes into Avon, Avon into Severn, Severn into the narrow seas, they into the main ocean; and thus the ashes of Wickliffe are the emblem of his doctrine, which now is dispersed all the world over.' Pop. of parish 1800.

Lüttich. See LIÉGE.

Lüttringhausen, a manufacturing town of Rhenish Prussia, 5 miles SE. of Elberfeld. Cloth, calico, and silk, hardware, and brandy manufactures are carried on. Pop. 10,498.

Lützen, a small town of 3501 inhabitants, in the Prussian province of Saxony, famous for two great battles fought in its vicinity. The first, a brilliant victory of the Swedes in the Thirty Years' War, took place on 6th November 1632 (see GUSTAVUS ADOLPHUS). The battle on 2d May 1813 was fought somewhat farther to the south, at the village of Gros-görschen. It was the first great conflict of the united Russian and Prussian army with the army of Napoleon in that decisive campaign; and the French were left in possession of the field.

Lützw, LUDWIG ADOLF WILHELM, FREIHERR VON, born in Brandenburg on 18th May 1782, died at Berlin on 6th December 1834, gave his name to a celebrated corps of volunteers, raised in Silesia during the war of liberation in 1813. It included several celebrated men, as Jahn, Theodor Körner, &c., and was renowned for its ardent patriotism and magnificent courage. The men uniformed themselves, and are often spoken and sung of as the 'Black Rifles' (*Jäger*). Lützw's wife was the Countess of Ahlefeldt, the friend of Immermann.

Luxembourg, DUC DE. François Henri de Montmorency-Bouteville, one of Louis XIV.'s celebrated marshals, was born at Paris on 8th January 1628. A posthumous son, he was trained by his aunt, mother of the Great Condé, to whom he stuck faithfully all through the wars of the Fronde. After 1659 he was pardoned by Louis XIV., who created him Duc de Luxembourg (1661) — he had just married the heiress of the House of Luxembourg-Piney. He again took the field in 1667, serving under Condé in the invasion of Franche-Comté; but, receiving an independent command against the Netherlands in 1672, he successfully invaded the enemy's country, and when compelled to retreat in the winter of

1673 led back his men in such a masterly way as to win the reputation of being one of the greatest generals of the age. His chief exploits during the continuance of the war were to storm Valenciennes and to defeat the Prince of Orange at Mont-Cassel and St Denis. He had been made marshal in 1675. Soon after the conclusion of peace (1678) he quarrelled with the all-powerful minister Louvois, and was not employed again on active duty for twelve years. The story that Louvois implicated him in the affair of the poisoners of Paris is probably a myth, though Luxembourg seems certainly to have spent some part of 1680 in the Bastille. In 1690 he was sent to take command in Flanders, and defeated the allies at Fleurus, and in the following year he twice more routed his old opponent, William III. (formerly Prince of Orange) at Steinkirk and near Neerwinden. He died at Paris on 4th January 1695. Luxembourg had an unerring instinct of the right thing to do on the field of battle, and when to do it. In action he was prompt and bold; but often failed to reap the full advantages of victory owing to his indolence. He was a little man and hump-backed, and addicted to self-indulgence.

Luxemburg, an independent grand-duchy of Europe, wedged in between France, Prussia, and Belgium. It consists of a plateau, furrowed with valleys, and connecting together the uplands of Lorraine, the Forest of Ardennes, and the Eifel; nearly all its streams flow to the Moselle, which for some 20 miles forms its eastern border. The country is well wooded, yields wheat, flax, hemp, and rapeseed, grows wine (1½ million gallons in good years), and is rich in iron ore. The extraction and smelting of this mineral is, next to agriculture, the principal occupation. But leather, gloves, pottery, cloth, paper, sugar, beer, and spirits are manufactured. Area, 998 sq. m.; pop. (1871) 197,528; (1890) 211,088, nearly all Catholics, and of Low German stock, though French is the language of the educated classes. For commercial purposes Luxembourg is included in the German customs union. The dignity of grand-duke belongs to the head of the House of Orange-Nassau, and as such was held by the kings of Holland from 1815 to 1890, when, on the death of King William III. without male issue, it passed to Adolf, Duke of Nassau. The little state is ruled by a House of forty-five Representatives. The head of the government is the minister of state, with whom are associated directors of finance, justice, and internal affairs.—The *Belgian province* of Luxembourg, which down to 1839 formed part of the grand-duchy, lies contiguous to this last on the west; it constitutes the south-eastern extremity of the kingdom of Belgium. In its physical features and its main product it differs little from its neighbour-state, the grand-duchy. Area, 1706 sq. m.; pop. (1891) 212,041. Chief town, Arlon. The *history* of the grand-duchy of Luxembourg begins with the history of the city. On the site of this there stood in the 8th century a castle, which in 738 was given by Charles Martel to the abbey of Treves. The founder of the first line of counts was Siegfried, who in 963 acquired the castle of Lucilinburch or Lutzellurg (i.e. Luxembourg). In 1136 the countship passed to the Counts of Namur. The fourth Count Henry was elected emperor as Henry VII. in 1308, and his son John became king of Bohemia. In 1354 the title was raised from count to duke. In 1444 the duchy was united with Burgundy, and shared the history of that state down to 1659, but it was reckoned a member of the German empire. From 1659 to 1713 Luxembourg was held by the French king. It was again annexed by the French in 1795, and two years later made the department of Forêts. But in 1815 the Vienna Congress created

it a separate state, a member of the German Confederation, but gave it to William I. of Holland. And this position was again declared definitive of the eastern section in 1839. By the London treaty of 1867 it was made a completely independent state, and the Prussian garrison withdrew from the fortress of Luxemburg. **LUXEMBURG**, the capital of the grand-duchy, by rail is 42 miles N. of Metz and 32 SW. of Treves. Its situation has often been compared to that of Jerusalem: the city stands on a rocky platform, connected with the neighbouring country only on the west, and elsewhere engrift by a steep valley, 200 feet deep, in which nestle the industrial suburbs of Klausen, Pfaffenthal, and Grund. The intermediate gorges are crossed by fine viaducts. The Spaniards, Austrians, French, and Dutch, who successively held possession of the town, so increased and strengthened its fortifications, hewn, like those of Gibraltar, in great part out of the solid rock, that in the beginning of the 19th century it was considered to be, with the exception of Gibraltar, the strongest fortress in Europe. But they were demolished in accordance with the treaty of London of 1867, and the site of the walls has been laid out as beautiful gardens. There are in the town the ruins of Count Mansfeld's palace and the cathedral (built in 1613). Pop. (1875) 15,954; (1890) 18,187.

See works by Coster (1869), Schötter (1882), Werveke (1886), Eyschen (1889), and Philips (1894), all in German; and one in French by Glasener (1885).

Luxeuil, a French town in Haute-Saône (pop. 4550), 15 miles NW. of Belfort, with remains of the monastery founded by St Columbanus in 590.

Luxor. See THEBES.

Luynes, Duc DE (1578-1621), the unworthy favourite of Louis XIII. of France, was a page at the court of Henry IV., and became ultimately peer of France and chancellor.

Luzern. See LUCERNE.

Luzon, the largest of the Philippines (q.v.).

Luzula, a genus of plants of the natural order Junaceæ, differing from rushes in having a 3-seeded



Field-rush
(*Luzula campestris*).

instead of a many-seeded capsule, and in having soft plane leaves, which are generally covered with thinly-scattered longish hairs. They do not grow in wet places, like rushes, but in woods, pastures, and elevated mountainous situations (see RUSH). Perhaps there is no more common British plant than the Field-rush (*L. campestris*), a plant of very humble growth; its flowering spikes congregated into a close head, their dark colour relieved by the whitish yellow of the anthers, profusely adorn dry pastures in spring. It is of no agricultural value. The species which grow under the shade of trees preserve their verdure in winter, adding to the beauty of the scene, and improving the cover for game.

Lyall, EDNA, the pen name of Ada Ellen Bayly, author of several popular novels written with a purpose, was born and educated at Brighton, had vague ideas of becoming a novelist even in her tenth year, and at school wrote a good deal of

amateur fiction. Her first novel, *Won by Waiting* (1879), was followed by her most popular story, *Dunorran* (1882), written at Lincoln, with its sequel *We Two* (1884); these are a plea for that charity which takes no account of even the sharpest differences in creed and religion. Her other books are *In the Golden Days* (1885); *Knight Errant* (1887), partly written in Italy, where most of the ideas for this novel were derived; *Autobiography of a Slander* (1887); *Derrick Vaughan* and *A Hardy Norseman* (1889); and a child's book, *Their Happiest Christmases* (1889). Her novels are characterised by thought and quiet humour; her descriptions of both nature and human nature are usually vivid and graceful, and coloured by her own experience of travel. Most of her tales turn on self-sacrifice, while the *Autobiography of a Slander* is directed against the sins of the tongue. She conceives her characters first, then surrounds them with the chain of circumstance for the due development of the story. Like George Eliot with the Liggins imposture, the real 'Edna Lyall' has had to assert herself against an impostor in Ceylon who had adopted her name. Statistics of the books read at several libraries show Edna Lyall's novels to have been most in demand over a certain period.

Lycanthropy. See WERE-WOLF.

Lycæonia, in ancient geography, a country in Asia Minor, bounded E. by Cappadocia, N. by Galatia, W. by Pisidia, and S. by Isauria and Cilicia. Its capital was Ieonium (q.v.).

Lycæum (Gr. *Lukion*), originally the name of a place in the immediate neighbourhood of Athens, consecrated to *Apollon Lycæus*, and noted for its shady wood and beautiful gardens, but particularly for its gymnasium, in which Aristotle and the Peripatetics taught, and from which the Romans borrowed the same name for similar institutions. In more modern times the name lycæum was given in honour of Aristotle to the higher Latin schools in which the Aristotelian philosophy formed a principal branch of education; and at the present day the name is variously applied to educational and literary institutions, especially to the French schools called Lycées (see FRANCE). The term lycæum is frequently employed in America for what would be called in England an academy, association, or society. It may signify also the building in which the society meets.

Lych-gate (A.S. *lic* or *lice*, 'a body,' 'corpse'), or CORPSE-GATE, a churchyard gate covered with a roof. It is very common in many parts of England

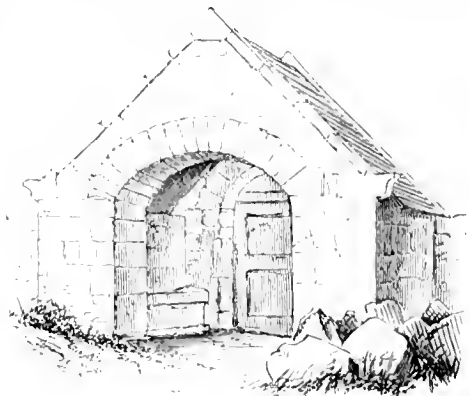

Lych-gate.

and Wales. The bodies of persons brought for burial are set down under the shelter of the roof while the opening words of the service are read.

Lych gates are very rare in Scotland; the illustration represents one at Blackford Church, in Perthshire.

Lychnis, a genus of plants of the natural order Caryophyllaceæ. They are herbaceous plants, generally perennial, and natives of temperate countries. Several are found in Britain. The Ragged Robin (*L. flos cuculi*) is one of the most frequent ornaments of meadows and moist pastures; the German Catchfly (*L. viscaria*) is very rare, and generally found growing on almost inaccessible precipices; the Red Campion (*L. diurna*) and the White Campion (*L. vespertina*) abound in fields, hedges, and the borders of woods. The last two are dioecious, and, strangely enough, the female of the first and the male of the second are very common, while the male of the first and female of the second are rather rare. The flowers of *L. vespertina* are usually fragrant in the evening. The Scarlet Lychnis (*L. Chalcedonica*), a native of Asia Minor, is a frequent and brilliant ornament of flower-borders. Some of the species have saponaceous properties.

Lycia, a country on the south coast of Asia Minor, bounded on the W. by Caria, on the N. by Phrygia and Pisidia, and on the E. by Pamphylia. It is a mountainous region, formed by lofty spurs of the Taurus, which reach 10,000 feet in height; the valleys are very fertile. The most ancient inhabitants are said to have been two races called Solymi and Termike. The Lycians are prominent in the Homeric legend of the Trojan war. Lycia maintained its independence against Croesus, king of Lydia, but was afterwards made subject to the Persians and Syrians, and then to Rome. During the time of its independence it consisted of twenty-three confederate cities, of which the principal were Xanthus (the capital), Patara, Pinara, Olympus, Myra, and Thos; and at the head of the whole confederation was a president or governor called the Lyciarch. Many monuments and ruined buildings (temples, tombs, theatres, &c.) and other antiquities testify to the attainments of the Lycians in civilisation and the arts, which they seem to have derived in large measure from Greek sources. Sir Charles Fellows, about 1840, was the first to discover and point out the interesting character of these Lycian remains. A beautiful collection is preserved in the British Museum. There exist also inscriptions in which a peculiar alphabet is used, closely modelled upon the Greek, the language of which appears to be inflected like the Indo-Germanic languages, and was probably akin to Zend.

See Fellows, *Discoveries in Lycia* (1841); Spratt and Forbes, *Travels in Lycia* (1847); M. Schmidt, *The Lycian Inscriptions* (1862); Sayer, *Principles of Comparative Philology* (3d ed. 1885); and Treuber, *Geschichte der Lyker* (1887).

Lycopodiaceæ form a class of isosporous vascular Cryptogams, containing two orders with four genera. Order I.: Lycopodiæ includes the genus *Lycopodium*, with about 100 species which are universally distributed; and the genus *Phylloglossum* with only one species (*P. Drummondii*), found in Australia and New Zealand. Order II.: Psilotæ includes the genus *Psilotum*, with two species which are found in the tropics of both hemispheres, and the genus *Tmesipteris*, with only one known species, which is epiphytic on tree ferns in the southern hemisphere.

Of the four genera the *Lycopodium* is best known under the name of 'Club-moss' or 'Stag's horn moss,' but there is no more than a superficial resemblance between it and the true mosses (Musci). The stem may be creeping as in

L. clavatum, the common club-moss of the British Isles, erect as in *L. Selago*, which is also a British species, or shrubby and stout as in some tropical species.

The Lycopodiaceæ have mostly a dichotomous form of branching. The stems, except in the shrubby forms, are slender, and never reach more than a few feet in length. The leaves are small and undivided, usually overlapping and completely protecting the stem. Special branches are spore-bearing, and one sporangium is borne in the axil of each leaf. Only in some fossil forms are there two kinds of spores (heterosporous). The spore develops a green prothallus, which sends root-hairs into the soil, or a colourless, tubercous subterranean prothallus; but both forms produce on the same individual antheridia and archegonia; the former produce spermatozoids, and the latter oospheres. Fertilisation occurs as in the Fern (q.v.). The sporophyte plant which results from the fertilisation of an oosphere by a spermatozoid is the conspicuous generation, while the oophyte or prothallus is the inconspicuous generation. The roots are simple, and may arise at any point of the stem near the ground. A number of flattened vascular bundles unite at intervals longitudinally in the centre of the stem to form a single axile cylinder, which is surrounded by a sheath, while the rest of the stem around

this is made up of thick or thin walled cells. The elements of the bundle resemble those of ferns. A simple strand passes from the axile cylinder to the midrib of each leaf. Alternation of generations is very strongly marked in *Lycopodium*, but vegetative reproduction of the sporophyte may occur by means of bulbils in the axils of the leaves or on the roots, or by means of adventitious buds on the stems.

The Lycopodiaceæ are very closely related to the higher forms, the Selaginellaceæ, which are heterosporous plants, and to the lower forms, the Ferns, which have simpler sporangia.

The spores of *Lycopodium* are used for coating pills, and the hands rubbed over with the spores may be dipped in water without being wet; they are also used for flash lights in pyrotechnic displays. Many species are medicinal. *L. clavatum* is emetic, and *L. Selago*, cathartic. The spores of many form a powder which is beneficial in ulcerations, &c., and *L. alpinum* is used as a dye. The Lycopodiaceæ may be regarded as the degraded survivors of tree-like forms that were very plentiful in the forests of the Carboniferous period.

Lycurgus, the lawgiver of Sparta, is usually dated about 820 B.C. He was uncle of the young king Charilaos, and governed the state wisely during his nephew's infancy, then travelled over Crete, Ionia, and Egypt, and on his return, finding his country in complete anarchy, made a new division of property, and remodelled the whole constitution, military and civil. Next he bound the citizens by oath not to change his laws until he came back, and then left Sparta to be no more seen. His



Club-moss (*Lycopodium clavatum*):
a, roots; b, creeping stem; c, upright stem; d, vegetative branches; e, stalk bearing the sporangiferous branches; f, f', g, spore-bearing leaf; g, same in section; h, h', sporangium; i, vein of spiral vessels.

memory was honoured as that of a god with a temple and yearly sacrifices.

Lycurgus, an Attic orator, born about 396 B.C., was a pupil of Plato and Isocrates, and warmly supported Demosthenes' policy. He was thrice appointed manager of the revenue. He died in 328. Of his fifteen speeches but one is extant.

Lyddite, a powerful explosive (like melinite), made from picrate of potash. It is made at Lydd, near New Romney, in Kent, where there is a Government artillery range. See **PICRIC ACID**.

Lydgate, JOHN, an admirer and imitator of Chaucer, was born at Lydgate, near Newmarket, in Suffolk, about 1370, and became a monk in the Benedictine monastery of Bury St Edmunds. He studied some time at Oxford, travelled into France and Italy, and returned a master of their poetry. In the monastery he appears to have taught the rhetoric and philosophy of his time, and he wrote poetry with equal ease upon the most widely different themes. His death probably occurred about 1450, and we have his own evidence that his last years were harassed by poverty. Until his old age he seems to have been more of the poet than the monk, but among his later works are a metrical *Life of St Edmund* and the *Legend of St Alban*. Ritson has enumerated in his *Bibliographia Poetica* no fewer than 251 pieces written by Lydgate, and most probably even this list is incomplete. A selection from the minor poems was edited by Mr Halliwell for the Percy Society in 1840. Lydgate's longer works are the *Storie of Thebes*, the *Troy Book*, and the *Falls of Princes*. The *Storie of Thebes* is represented as a new Canterbury tale, told by the author after joining the company of pilgrims at Canterbury. It is written in rhyming ten-syllable couplets, and contains about 4780 lines. Its sources are the *Thebaid* of Statius and the *Teseide* of Boccaccio. The versification is rough, and, indeed, it cannot be denied that the poem is dull and prolix to a degree, the prologue alone excepted. The *Troy Book* was undertaken about 1412, at the request of Prince Henry, afterwards Henry V., and was finished in 1420. It is written also in the ten syllable couplet, and is divided into five books, and founded on Guido di Colonna's Latin prose *Historia Trojana*. Its best-known passage is the long panegyric on his 'Maister Chaucer' in the third book. The *Falls of Princes*, divided into nine books, is written in Chaucer's seven-line stanza, and contains upwards of 7000 stanzas. It was written in 1430 by desire of Humphrey, Duke of Gloucester, and is founded on a French paraphrase by Lawrence de Premierfait of Boccaccio's Latin work, *De Casibus Virorum Illustrium*. Other works that may merely be mentioned here are the *Dance of Macchabe*, or Dance of Death, translated from the French; the *Court of Sapience*; and the *Temple of Glass*, a copy of Chaucer's *House of Fame*.

Lydia, anciently a country of Asia Minor, bounded on the W. by Ionia, on the S. by Caria, on the E. by Phrygia, and on the N. by Mysia. It is said to have been originally inhabited by a people called Meonians, though the Lydians, an allied tribe, probably occupied the plain of Sardis. The country was celebrated for its fruitful soil—except the barren *Katakakmaene* (burned up) volcanic region in the east—and its mineral wealth, particularly for the gold of the river Pactolus and of the neighbouring mines of Tmolus, but was in later ages infamous for the corruption of morals which prevailed amongst its inhabitants, and especially in Sardis (q.v.), its capital. The Lydians, shut out from the Aegean Sea by the Ionian Greeks, developed great commercial activity inland. They likewise distinguished themselves in the textile arts. They

were believed to have been the inventors of coined money, and of dice and other games. Many elements of their civilisation seem to have been derived from the Hittites; Hittite governors ruled for some time at Sardis. The sun-god Attys and Cybele, the mother of the gods, the Hittite-Babylonian Tammuz and Istar, were the deities principally worshipped. Three dynasties are recorded to have ruled over ancient Lydia: the first, wholly mythical, was founded by Attys; the second, usually called the Heraclid, from its founder being a reputed son of Hercules by Omphale, has been identified with the Hittites; the third was founded by Gyges about 690 B.C. This king created a powerful Lydian empire, which attained its greatest period of splendour under his descendant Croesus (q.v.) the rich, who was slain by Cyrus the Persian in 546. Sardis thereafter became the western capital of the Persian empire. Lydia was subsequently subject to Athens, Macedonia, and Rome one after the other. The merest fragments remain of the language, which was apparently Indo-European. For the Lydian mode, see **HARMONY**; and for Lydian stone, **TOUCH-STONE**.

Lye, a term sometimes used to denote all solutions of salts, but more generally appropriated to solutions of the fixed alkalis, potash and soda, in water. The solutions of caustic potash and soda are called caustic lyes; those of their carbonates, mild lyes. The fluid which remains after a substance has been separated from its solution by crystallisation is called the *mother lye*.

Lyell, SIR CHARLES, geologist, was the eldest son of Charles Lyell, Esq., of Kinnorly, Forfarshire, where he was born 14th November 1797. After receiving his early education at Midhurst, in Sussex, he entered Exeter College, Oxford, and graduated as B.A. in 1819. At Oxford he attended the lectures of Buckland, and thus acquired a taste for the science he afterwards did so much to promote. After leaving the university he studied law, and in due time was called to the bar; but his circumstances not rendering a profession necessary for a livelihood, he devoted himself to geology, and made tours in 1824, and again in 1828-30, over various parts of Europe, and published the results of his investigations in the *Transactions of the Geological Society* and elsewhere. His great work, *The Principles of Geology* (3 vols. 1830-33), may be ranked next after Darwin's *Origin of Species* among the books which have exercised the most powerful influence on the direction of scientific thought in the 19th century. It broke down the belief in the necessity of stupendous convulsions in past times; and taught, as had long before been maintained by Hutton and Playfair, that the greatest geological changes might be produced by the forces still at work on the earth. It was subsequently divided into two parts, published as two distinct works—viz. *The Principles of Geology; or the Modern Changes of the Earth and its Inhabitants* (12th ed. 1876); and *The Elements of Geology; or the Ancient Changes of the Earth and its Inhabitants. The Geological Evidences of the Antiquity of Man* (1863) startled the public by its unbiased attitude towards Darwin's *Origin of Species*. Lyell also published *Travels in North America* (1845) and *A Second Visit to the United States* (1849). During the second sojourn, when he also visited Nova Scotia, he estimated the recession of the rock at Niagara, and the amount of deposition of alluvium at the delta of the Mississippi. On the opening of King's College, London, in 1832 Lyell was appointed professor of Geology, an office which he soon resigned. In 1836, and again in 1850, he was elected president of the Geological Society,

and in 1864 president of the British Association. He was knighted in 1848, and created a baronet in 1864. He died 22d February 1875, and was buried in Westminster Abbey. See his *Life, Letters, and Journals* (2 vols. 1881); and the article GEOLOGY.

Lykewake. See WAKE.

Lyly, JOHN, romance-writer and dramatist, was born in the Weald of Kent about 1553. He became a student of Magdalen College, Oxford, in 1569; B.A., 27th April 1573; M.A., 1st June 1575. In Lansdowne MS. 19 is preserved a Latin letter (written in 1574) in which he begs Lord Burghley to help him towards procuring a fellowship at Magdalen College; but the application does not appear to have been successful. He afterwards studied at Cambridge, where he was incorporated M.A. in 1579. Failing to gain preferment at the universities, he followed the court. Among the Harleian MSS. are two undated petitions to Queen Elizabeth, begging that he might be appointed Master of the Revels. In the first he writes: 'I was enterteyned yo^r Ma^s s^vant by yo^r owne gracious fauour, strengthened with condicions, that I should ayme all my courses at the Reuells (I dare not saye with a promise, but a hopefull Item to the reu^econ) for w^{ch} these 10 yeres I have attended with an unwearyed patience, and nowe I knowe not what Crabb took me for an Oyster, that in the midst of yo^r sunshine of your most gracious aspect, hath thrust a stone betwene the shells to eate me alive that onely live on deal hopes.' The tone of the second letter is even more desponding: 'Thirteene yeres your highnes seruant, but yet nothing. . . . A thousand hopes, but all nothing: a hundred promises, but yet nothing.' He found a patron in Lord Burghley, who gave him some post of trust in his household. In 1589 he took part in the Martin Marprelate controversy, and incurred the enmity of Gabriel Harvey, who described him in *Pierce's Supercroption* (1593) as 'a mad lad as ever twanged, never troubled with any substance of witt or circumstance of honestie, sometime the fiddle-sticke of Oxford, now the very bable (hauble) of London.' The authors of *Athenæ Cantabrigienses* (ii. 326) state that he was returned for Aylesbury to the parliament of 19th February 1592-93; for Appleby, 24th October 1597; and again for Aylesbury, 7th October 1601. In December 1597 he addressed to Secretary Cecil a letter expressing disappointment at not obtaining advancement. From the register of St Bartholomew the Less, London, it appears that he was buried 30th November 1606. He was married, and had children, was short of stature, and very fond of tobacco.

Lyly's most famous work is his *Euphues*, a romance in two parts. The first part, *Euphues, the Anatomy of Wit* (4to), was published in the spring of 1579; the second part, *Euphues and his England*, followed in 1580. In court circles the romance was received with great applause. Edward Blount, the publisher, who collected Lyly's plays in 1632, declared: 'Our Nation are in his debt for a new English which hee taught them. . . . All our Ladies were then his Schollers; And that Beantie in Court which could not Parley Euphuesisme was as little regarded as shee which now there speaks not French.' In the *Monastery* Scott drew, in the person of Sir Piercy Shafton, the character of a euphuistic gallant; but the portrait is barely recognisable. One peculiarity of this 'new English' is the constant employment of similes drawn from fabulous stories (of classical and mediæval writers) concerning the properties of animals, plants, and minerals. Another is the excessive indulgence in antithesis. Lyly cannot relate the simplest incident without introducing antithetical flourishes and fetching illustrations from bestiaries and

herbals. This unnatural style of writing was not Lyly's invention, but was to a large extent modelled (as Professor Landmann has shown) on the example of the Spanish writer Guevara. Lord Berners and others had translated works of Guevara; but the Spaniard's claims were forgotten, and Lyly was regarded as the pattern of refinement. Greene, Lodge, and others set themselves to imitate *Euphues*, but their affectations were seldom so deliberately extravagant as Lyly's. Later the euphuistic style was held up to derision. Drayton speaks scornfully of

Lyly's writing then in use;
Talking of stones, stars, plants, of fishes, flies,
Playing with words and idle similes.

The matter of *Euphues* is more commendable than the manner. Sound advice is offered on the subject of friendship, love, travel, the nature and education of children, morality, and religion.

Lyly's comedies (which were performed before the queen by children's companies) are more readable than his romance. The earliest, as we learn from the prologue, was *The Woman in the Moone*, first printed in 1597, but produced in or before 1583. *Campaspe* and *Sappho and Phao* were published in 1584; *Endimion* in 1591; *Gallathea* and *Midas* in 1592; *Mother Bombe* in 1594; and *Love's Metamorphosis* in 1601. With the exception of *The Woman in the Moone*, these comedies (on pastoral and mythological subjects) were written in prose. Though they display little dramatic power, they are fanciful and attractive entertainments. Frequently the dialogue is pointed and sparkling. The delightful songs were first printed in the collective edition of 1632: 'Cupid and my Campaspe played' is in modern anthologies.

Lyly's plays were edited by Fairholt in 1858; *Euphues* by Arber (1868); the *Endimion* by Mr G. T. Baker (1895). See C. G. Child's *Lyly and Euphuism* (1894).

Lyme Regis, a seaport and watering-place of Dorsetshire, at the mouth of the Lyme rivulet, 5 miles SE. of Axminster and 23 W. of Dorchester. The Cobb breakwater, dating from the 14th century, was reconstructed by government in 1825-26. Chartered by Edward I., and incorporated by Elizabeth, Lyme returned two members till 1832, and then one till 1868. It beat off Prince Maurice (1644), and was Monmouth's landing-place (1685). Natives have been Sir George Somers, Captain Coram, and Miss Mary Anning, the discoverer of the Ichthyosaurus and Plesiosaurus in the Lias rocks here, which are largely quarried. Pop. (1851) 2361; (1881) 2047; (1891) 2365. See Roberts' *History of Lyme Regis* (1834).

Lymington, a municipal borough of Hampshire, at the mouth of the Lymington River in the Solent, 12 miles (by a branch-line 18) SW. of Southampton. The salt works belong to the past; and yacht-building is now the principal industry. Lymington is also of some importance as a watering-place. It commands fine prospects of the Isle of Wight, and its vicinity abounds in charming scenery. Till 1867 it returned two members to parliament, and then till 1885 one. Pop. (1851) 2651; (1881), with extended area, 4551. See works by Garrow (1825), Grove (1835), and King (1879).

Lymph (Gr. *lymphā*, 'water') is the term applied by physiologists to the fluid contained in the Lymphatics (q.v.). It is a colourless or faintly yellowish fluid, of a rather saltish taste, and with an alkaline reaction. It coagulates shortly after its removal from the living body, and forms a jelly like, semi solid mass, which continues for some time to contract, so that at last the clot is very small in proportion to the expressed serum. On microscopic examination the lymph is seen to contain corpuscles which do not in any respect

differ from the colourless blood-cells, molecular granules, fat-globules, and occasionally blood-corpuscles.

Lymphatics arise in the form of a network of lymph capillaries which lie in the minute inter-cellular spaces of the body, and in addition form



Diagram of Lymphatic System:

a, small artery or capillary from which lymph (blood-plasma) exudes; b, cell bathed by lymph; c, small lymphatic into which lymph collects; d, lymphatic gland; e, vein into which the lymph is returned.

large lymph cavities, such as the peritoneal, pleural, &c. The lymph is then conveyed by larger and larger vessels, to the venous system, on entering which it mixes with the blood. The lymph of the left side of the trunk, of both legs, of the left arm, and the whole of the chyle is conveyed into the blood by the thoracic duct; while the lymph of the right side of the head, neck, and trunk, and of the right arm, enters the circulation at the junction of the axillary and internal jugular veins on the right side by a short trunk, guarded at its opening by valves. On its way the lymph passes through small glands of the size of a pea or bean called lymphatic glands. Thus, those of the arm pass through the lymphatic glands of the axilla, those of the leg through the glands of the groin, and those of the head and face through the glands of the neck.

The lymph arises primarily from the fluid part of the blood which exudes from the capillaries, bathes the cells and tissues of the body, and then, after supplying them with food and receiving their excretions, passes on once more to enter the circulation, being carried there by the lymphatic vessels. The corpuscular elements are chiefly the products of the lymphatic glands. See CHYLE. CIRCULATION.

Lynchburg, a city of Virginia, lies in a picturesque mountain-region, on the James River, which is here spanned by several bridges, 124 miles by rail W. by S. of Richmond. It is a thriving place, with the electric light and electric trams, and has several foundries, a cotton-mill, a fruit-canning factory, and manufactories of nails, farming implements, fertilisers, and furniture, besides tobacco, which is the staple of the town's trade. There are twenty-four leaf-tobacco factories, and an even larger number of others. Pop. (1880) 15,959; (1890) 19,709.

Lynch Law, the summary trial and punishment of offenders by private and unauthorised persons. This mode of administering justice has been necessarily employed in countries newly settled, where the power of the civil government is not yet sufficiently established. The frequency with which it has been resorted to in the southern and western states of the American Union, however, as a punishment for serious criminal offences, is to be referred rather to a doubt on the part of the mob as to the adequacy of the ordinary legal machinery. In the six years 1884-89 the number of murders in the United States was reported as 14,770, of legal executions 558, and of lynchings 975. Of course, the infliction of any minor punishment without legal trial constitutes lynch law (see VIGILANCE SOCIETIES), but the simple term 'lynching' usually implies capital punishment. The phrase has been variously traced to a Virginia soldier and to a Virginia farmer of

that name, to one Lynch who was sent out from England about 1687 to suppress piracy, and to a mayor of Galway (q.v.) in Ireland; while yet another tradition refers it to Lynch Creek, in North Carolina, where the forms of a court-martial and execution were gone through over the lifeless body of a Tory, who had already been precipitately hanged to prevent a rescue.

Lyndhurst, a Hampshire village, the capital of the New Forest, 9 miles SW. of Southampton. Its church (1863) is a brick Early English-structure, with conspicuous spire, good stained glass, a monument by Flaxman, and a fresco by Leighton of the 'Ten Virgins.' Near it is the verderers' hall, with Rufus's stirrup. Pop. of parish, 1589.

Lyndhurst, JOHN SINGLETON COPLEY, BARON, thrice Lord Chancellor, was the son of J. S. Copley, R.A. (q.v.), and was born at Boston, Massachusetts, 21st May 1772. At three, with his mother, he followed the painter to London, where, from 1780 till his death, his home was at 25 George Street, Hanover Square; and, after a private education at Chiswick, in 1790 he entered Trinity College, Cambridge. In 1794 he came out second wrangler and second Smith's prizeman, next year got a fellowship, and in 1796 paid a six months' visit to the States, travelling through them with Volney. On his return to England he began to study for the bar, to which, however, he was not called till 1804, when he joined the Midland circuit. He worked assiduously, but success was 'very, very slow' till 1807, and not assured till 1812, when he made a real hit by his ingenious defence of a Luddite rioter. In 1817 he obtained the acquittal of Thistlewood and Dr Watson on their trial for high-treason; but for the next state prosecution, four months afterwards, the government secured him on their side, and in 1818 he entered parliament for a government borough. Henceforward, whatever his former politics, he continued a fairly consistent Tory, and as such his promotion was rapid. In 1819, as Sir John Copley, he became Solicitor-general, in 1824 Attorney-general, and in 1826 Master of the Rolls. When Canning was charged to form a ministry he offered the Great Seal to Copley, who was raised to the Upper House as Baron Lyndhurst; he remained Lord Chancellor under three administrations from 1827 to 1830. At the close of the latter year his Whig opponents made him Chief-baron of the Exchequer, which office he exchanged for the wool-sack during Peel's brief administration (1834-35). He next led the opposition in the Upper House to the Melbourne ministry, his annual reviews of the session doing much to reanimate his party and pave the way for its return to power in 1841. He then for the third time became Lord Chancellor, and held the Great Seal till the defeat of the Peel government in 1846. After that time he took little part in home politics, but his voice was often heard on matters of foreign policy. Threatened with blindness for the last fourteen years of his life, he died 12th October 1863, at the great age of ninety-one. Lyndhurst's attainments as a clear-headed lawyer have never been questioned; his judgments— that, for instance, in the great case of *Small v. Atwood* (1832)—have never been excelled for lucidity, method, and legal acumen. In the House of Peers he had not his equal as a debater. Still, he was not a great statesman, lawgiver, or orator, mainly perhaps through lack of earnestness. His character has been blackened by Lord Campbell (*Lives of the Chancellors*, vol. viii. 1869), and enlarged by Sir Theodore Martin (*Life of Lord Lyndhurst*, 1883). For the act that goes by his name, see DECEASED WIFE'S SISTER.

Lyndsay, or LINDSAY, SIR DAVID, OF THE MOUNT, one of the best, and long the most popular of the older Scottish poets, was the son of David Lyndsay of Garmilton (now Garleton), in East Lothian, whose grandfather was a son of Sir William Lyndsay of the Byres. The poet is said by Chalmers to have been born at the Mount about the year 1490, but Laing in his recent edition of Lyndsay (1879) notes the absence of evidence on this point, Chalmers having apparently assumed it as a consequence of his supposition that the poet's father was 'David Lyndsay of the Mount', while Laing has shown that this was the poet's grandfather. The name of 'Da. Lindsay' occurs in the list of 'incorporated' students in St Salvador's College, St Andrews, for the year 1508 or 1509. It may be that of the poet. We cannot tell when he entered the royal service, but in October 1511 he is found taking part in a play acted before the court of James IV. In the following spring he was appointed 'keeper' or 'usher' of the prince who, when little more than a twelvemonth old, became James V.; and his verses preserve some pleasing traces of the care and affection with which he tended the king's infant years. His wife, Janet Douglas, had long the charge of the royal apparel. In 1524 the court fell under the power of the queen-mother and the Douglasses, and Lyndsay lost his place; but four years afterwards, when the Douglasses were overthrown, Lyndsay was made Lyon King-of-arms, and at the same time received the honour of knighthood. In this capacity he accompanied embassies to the courts of England, France, Spain, and Denmark. He appears to have represented Cupar in the parliaments of 1542 and 1543; and he was present at St Andrews in 1547 when the followers of the reformed faith called Knox to take upon himself the office of a public preacher. He died childless before the summer of 1555.

Two editions of Lyndsay's poems were published in France in 1558; and these editions, with a few pieces added, were republished by Charteris, an Edinburgh bookseller, in 1568. Numerous editions appeared subsequently, indicating the great popularity which Lyndsay long enjoyed. For fully two centuries, indeed, he was what Burns has since become—the poet of the Scottish people. His works were in almost every house, his verses on almost every tongue. Like Burns, he owed part of his popularity no doubt to his complete mastery of the popular speech. But, like Burns, Lyndsay would have been read in whatever language he chose to write. His verses show few marks of the highest poetical power, but their merits otherwise are great. Their fancy is scarcely less genial than their humour, and they are full of good sense, varied learning, and knowledge of the world. They are valuable now, if for nothing else than their vivid pictures of manners and feelings. In the poet's own day they served a political purpose, by preparing the way for the great revolution of the 16th century. It has been said that the verses of Lyndsay did more for the Reformation in Scotland than all the sermons of Knox. Like Burns, Lyndsay shot some of his sharpest shafts at the clergy. The licentiousness that characterises his verse must be attributed in part to the age in which he lived. The earliest and most poetical of his writings is *The Dreme*; the most ambitious, *The Monarchie*; the most remarkable in his own day, perhaps, was *The Satyre of the Three Estaites*; but that which is now read with most pleasure, both for the charm of its subject and for its freedom from the allegorical fashion of the time, is *The Hystorie of Spenser Mallevan*. A good edition of Lyndsay's works is that of Chalmers (3 vols. Lond. 1806); but in points of detail it is less

accurate than that of David Laing (3 vols. 1879). A number of his poems have been edited by J. Small and F. Hall for the Early English Text Society (4 parts, 1865-71); and the Scottish Text Society have undertaken a new edition.

Lyndsay of Pitcottie. See PITSCOTTIE.

Lynedoch, THOMAS GRAHAM, LORD, British general, was the son of the laird of Balgowan in Perthshire, and was born on 19th October 1748. He raised in 1793 the 90th regiment of foot, and with it served at Quiberon and Isle Dieu. He distinguished himself at the capture of Minorca (1798), conducted the siege of Valletta (Malta), which capitulated (1800) just after he was superseded in the command, took part in the retreat to Corunna and in the Walcheren expedition (1809), at Barrosa, near Cadiz, gained a splendid victory over the French (1811), and then under Wellington distinguished himself at the siege of Ciudad Rodrigo (1812), was present at Badajoz and Salamanca, commanded the left wing at Vittoria (1813), captured Tolosa and St Sebastian, and, lastly, commanded a body of troops in Holland, with which he defeated the enemy at Merxem, but failed in an ill-advised attempt to storm Bergen-op-Zoom (1814). Three months later he was created Baron Lynedoch of Balgowan, and in 1821 was promoted to the rank of general. He was the founder of the Senior United Service Club in 1817. He died in London, 18th December 1843. See Lives by J. M. Graham (2d ed. 1877) and A. M. Delavoye (1880).

Lynn, or KING'S LYNN, a seaport, parliamentary and municipal borough of Norfolk, at the mouth of the Great Ouse, 48 miles WNW. from Norwich and 99 N. by E. from London. It still retains traces of the ramparts and a fosse, which once guarded it on the landward side, and abounds in picturesque old timbered houses, ornamented with carved work. Of its four churches the principal are cruciform St Margaret's, varying in style from Norman to Perpendicular, and 240 feet long, with two towers, one of which till 1741 was surmounted by a spire 258 feet high—and St Nicholas (1146-74), with a modern spire (1869), which replaced one blown down in the same hurricane as that of St Margaret's. Other features of interest include the Red Mount Chapel, octagonal, noticeable for its richly-ornamented roof; the hexagonal tower of the Grey Friars; a grammar-school, founded in or before the reign of Henry VIII, at which Eugene Aram was once usher; a guildhall, in which is preserved the Red Register of Lynn, one of the earliest paper books in existence; custom-house (1683); hospital (1834-47); museum (1854), with a good collection of British birds; library (1883); and two extensive docks (1869-84), admitting vessels drawing 22 feet at spring-tides. A considerable trade is carried on in corn, oil cake, coals, and timber, and large numbers of shrimps are caught and sent to London; but the imports of port wine, for which Lynn was formerly noted, have of late years much fallen off. In Edward I.'s reign it was one of the principal ports of the kingdom; in 1397 it ranked fifth amongst the towns contributing 'loans' to meet the royal necessities; in 1474 the Hanse merchants had a factory or 'steelyard' here; and in the first half of the 16th century it was a flourishing seat of cloth manufacture. In 1549, during Ket's (q.v.) rebellion, one body of the insurgents was encamped here, and in 1643, during the Civil War, the town capitulated to the parliamentary force after three weeks' resistance. King John (who in 1204 granted the town its first charter), the dowager queen Isabel (a resident for twenty-eight years at Castle Rising, a few miles distant), Edward III., Henry

VI., Edward IV., Henry VII., and Oliver Cromwell all visited Lynn, which was the birthplace of John Capgrave the chronicler and of Bishop Keene; and the residence of the physician Sir William Browne, and of Dr Charles Burney. Pop. (1801) 10,096; (1891) 18,360. At Sandringham, 7½ miles N. by E. of Lynn, is a residence of the Prince of Wales, the house, completed in 1870, being in the Elizabethan style of architecture. See Richards' *History of Lynn* (2 vols. 1812).

Lynn, a city and port of Massachusetts, on Massachusetts Bay, 10 miles NNE. of Boston, with which it is connected by train and tramway. Most of the houses are built of wood; among them are many handsome villas belonging to Boston merchants. The principal industry is the manufacture of ladies' and children's shoes—mainly for the West and South of which 10,000,000 pairs have been produced in one year. There are also large tanneries here. Though founded in 1629, Lynn became a city only in 1850. A great fire here in 1889 destroyed property worth \$5,000,000. Pop. (1880) 38,274; (1890) 55,727.

Lynton and Lynnmouth, two villages of North Devon, on the Bristol Channel, 18 miles NE. of Barnstaple by rail (1896), 17 E. of Ilfracombe, and 20 W. of Minehead. Lynnmouth stands close to the sea, and Lynton half-way up the cliff, 428 feet above. They were 'discovered' in 1883, and have since been developed, now possessing a cliff-railway 1000 feet in vertical ascent, electric light, nine hotels, &c. Shelley stayed at Lynnmouth in 1812; and Southey called it 'the finest spot, except Cintra and Arrabida [near Lisbon], that I ever saw.' Joint population (1881) 1212; (1890) 2300.

LYNX, a genus of Felidae, having a less elongated form than many others of that family, the body elevated at the haunches, long fur, a short tail, and the ears tipped with tufts or pencils of hairs.



The European Lynx (*Lynx virgatus*).

They are less courageous than other Felidae of similar size, and prey on small quadrupeds and birds. It has been said that they kill and devour the skunk. In pursuit of birds they climb trees. They are generally of a sullen and suspicious temper, and not easily tamed. The species are not numerous, but widely distributed; the distinctions of species and varieties are somewhat uncertain. The European Lynx (*L. virgatus*) is common in many parts of Europe and Asia, chiefly in mountainous and wooded districts. Its colour is variable, but generally of a dark reddish gray, spotted with reddish brown, the belly whitish. It is about three feet long, and proverbial for acuteness of sight. It is hunted in winter for its fur, which is always in demand in the market; but many of the lynx skins imported from the north of Asia

probably belong to other species. Those of North America, and probably also many of those of the north of Europe and of Asia, are the skins of the Canada Lynx (*L. canadensis* or *L. borealis*), which is generally of a hoary gray colour, a broad space along the back being blackish brown. It is rather larger than the European Lynx, and more clumsy in form. The Bay Lynx (*L. rufus*) is found in more southern parts of North America, both in mountainous and in swampy districts, and often makes great havoc among poultry; it is commonly called in America the wild cat. But as all these forms graduate into one another they should probably be referred to a single species. The Asiatic species are the Caracal and the Tibet Lynx.

Lyon Court, the court in Scotland which has jurisdiction in questions regarding coat-armour and precedence. It is presided over by the Lyon King-of-arms. See HERALD.

Lyonnesse. See CORNWALL.

Lyonnais, a former province of France, was bounded on the W. by Auvergne and on the S. by Languedoc. Its territory coincides nearly with the present departments of Rhone, Loire, Haute-Loire, and Puy-de-Dome.

Lyons (Fr. *Lyon*), the second city of France, stands at the confluence of the Rhone and the Saône, by rail 315 miles SSE. of Paris and 218 N. by W. of Marseilles. The commercial and fashionable quarters of the city lie on the long narrow tongue of land between the rivers, and are connected with the suburbs beyond by more than twenty bridges. This central part of Lyons contains many narrow streets, with tall gloomy houses; but much has been done to lighten it since 1852 by the making of long straight, wide streets, and the opening up of squares. In this district stand the museum (1667), with valuable Roman antiquities, a library of 120,000 vols. and 1500 MSS., pictures by the great masters, and other art collections; the church of St Martin d'Ainay, the oldest in Lyons, going back to the 10th century; St Nizier Church, at first the cathedral, a fine 15th-century Flamboyant building, with the crypt in which St Pothimus is said to have officiated; the graceful town-house, built in 1646 and restored in 1702; the museum of arts and industry; the academy, with five faculties; the hospital, founded in the 6th century, and perhaps the oldest in France, though the present building dates only from 1773; and the arsenal. To the north lies the suburb of La Croix Ronsee, where the silk weavers dwell. Across the Saône, and on its right bank, is the steep, high suburb of Fourvières, the ancient *Forum Vetus* of Trajan, whose summit (410 feet) is now crowned by the church of Notre Dame (the new church begun in 1872). Here is the miracle-working image of our Lady of Fourvières that is believed to have preserved the city from the cholera in 1832, 1835, and 1850; it is visited by thousands of pilgrims annually, whose offerings cover the walls of the church. From its tower, which is surmounted by a gilded statue of the Virgin, 48 feet high, a view can be had of the distant Alps. On this elevated site too stands the church of St Irenæus, in the crypt of which are preserved what purport to be the bones of 19,000 Christian martyrs who perished in the persecution by Severus. At the foot of the hill next the Saône is the archiepiscopal cathedral of St John, of the 13th and 14th centuries, with magnificent stained glass windows of the same date and a celebrated cloek of 1598; the palace of the archbishop, who ranks as primate of France; and the law-courts. On the left bank of the Rhone, which is so low that it has to be protected with embankments to prevent it from overflowing and flooding the city, is the handsome new suburb of Les Brotteaux, termin-

ated on the north by the park of the Tête d'Or, in which are an oriental museum, a zoological collection, and a fine botanical garden; while more to the south is the squalid suburb of La Guillotière. Lyons possesses also a Roman Catholic University with three faculties, a first-class veterinary school, a school of art with 1200 pupils, of great value for the silk manufactures, a school of the industrial arts, a municipal library of 66,000 vols., a natural history and other museums, and a silk-conditioning house. The city is a fortress of the first rank, being defended by a double ring of forts. Pop. (1872) 301,868; (1891) 398,927, or, of the commune, 438,977. The staple industry is the silk; it is computed that there are in all, within the city and its environs, from 75,000 to 85,000 hand-loom and 20,000 power-loom employed in this manufacture. Raw silk is imported, principally from China (28 per cent.), Japan (24 per cent.), Italy and the Levant, and France, to the annual value of £2,124,650, and manufactured silk goods exported to the yearly value of £9,510,960; the annual production reaches in value £43,936,000. The commodities specially characteristic of the Lyons manufacture used to be heavy figured stuffs, such as velvets, satins, watered silks, plushes, moirés, and so forth; but of late years, owing to a change in taste or fashion, there has been a growing demand for lighter stuffs dyed in the piece. Silk-dyeing and printing give employment to nearly 4000 workmen; 25,000 more are engaged in the various chemical industries (dyes, starch, candles, soap), machinery-making establishments, foundries, brass-works, fancy-ware manufactories, gold and silver goods, hats, paper, mathematical instruments, and numerous minor branches. The admirable position of Lyons makes it a great emporium of trade between central and southern Europe. Besides importing silk raw and exporting it manufactured, chiefly to Great Britain and the United States, cotton is imported from America and Egypt, and a large amount of business done in cloth and linen, chestnuts, coal, charcoal, cheese, and wine and spirits. The list of notable persons born in Lyons includes Germanicus and the Roman emperors Claudius, Marcus Aurelius, and Caracalla, Jules Favre, Roland, Say, Suchet, the De Jussieus, Ampère, Recamier, Bonnet, Delorme, Meissonier, and Jacquard.

The Romans settled a colony here in 43 B.C. and made it the starting-point for their great network of highways through Gaul. It soon became the ecclesiastical metropolis of that great province and its first commercial and manufacturing town, under the name of Lugdunum. But ill fortune attended it: it was burned to the ground in 59 A.D., and again in 197; it suffered severely during the barbarian invasions; and was conquered by the Saracens in 736. Yet it was visited by gleams of glory: in 478 it was made capital of the Burgundian kingdom, and, passing to the empire in 1032, was invested with self-government and the privileges of a free imperial town. But after the condemnation of the Emperor Frederick II. at the Council of Lyons in 1245 the city reverted to the French crown. The introduction of the silk industry must be set down to the credit of Francis I. The Reformation, entering from Geneva, had a short but violent reign; the emigration of the Huguenots struck a blow at the industrial prosperity of the town from which it did not recover for some time. In 1789 the city embraced the cause of the Revolution, though royalist feeling was also strong here. In 1792 it refused obedience to the National Convention; in revenge it was besieged, captured, its buildings destroyed, its name changed (till 1794) to Ville-Afranchie, and 6000 of its citizens slain under the direction of Collot d'Herbois,

Couthon, and Fouché. The 19th century was chiefly memorable for trade riots, which sometimes, as in 1831, 1834, and 1849, assumed very formidable dimensions. Since the war of 1870 it has been known as a focus of red republicanism.

See Histories by Clerjon (4 vols. 1829-35), Beaulieu (1838), Monfalcon (8 vols. 1806-70), Metzger (9 vols. 1881-85), the topographical account by Joanne (1885), and works by Josse (1892) and Steycers (1895).

Lyre, one of the oldest forms of stringed instrument. It was introduced into Egypt from Palestine during the 18th dynasty, and was common among the Greeks even in the heroic times. Most of the barbarians who invaded the Roman empire were acquainted with the lyre, and must have independently attained the knowledge of it. The common Greek lyre was made of a tortoise-shell, with blocks inside, similar to those used in a violin, to modify the strain of the strings. The shell was covered with bull's hide, and two horns were fastened to one side of it, one horn at each extremity of the side. A piece of wood served as a crosspiece, and was fastened from the tip of one horn to the tip of the other. Seven strings of gut were tied to the crosspiece, the other ends being secured at the bottom of the shell. Pegs for the strings were added to the crosspiece by the later Greeks, likewise a bridge to prevent the strings touching the shell, and two sound-holes cut in the shell in order to increase its resonance. The lyre, unlike the lute, cannot be stopped by the fingers and its sounds thereby multiplied. Its sounds can be no more in number than its strings. Consequently, since the rise of the modern scale, the lyre, whose strings were never more than seven or eight in number, has been unable to cope with the growing exigencies of an intricate music, and has fallen into complete desuetude.

Lyre-bird, or LYRE-TAIL (*Menura*), a genus of birds, of which the best-known species (*M. superba*) is a native of New South Wales, where it is generally called the Lyre Pheasant. The proper place of this genus has been much disputed by ornithologists, though it undoubtedly belongs to the Passeres. A bird about the size of a pheasant, it frequents the brush, or sparsely-wooded country, in the unsettled parts of New South Wales, but retreats from the more inhabited districts, being extremely shy and difficult to approach. It is by far the largest of all song birds, and possesses the power of imitating the song of other birds and the sounds of other animals, imitating even the bark of the dingo. The tail of the male is very remarkable and splendid, twelve feathers being very long, and having very fine and widely-separated barbs; whilst, besides these, there are two long middle feathers, each



Lyre-bird (*Menura superba*).

of which has a vane only on one side, and two exterior feathers, curved like the sides of an ancient lyre. The lyre-bird makes a domed nest. A second species (*M. alberti*), also Australian, has been named in honour of Prince Albert. The lyre-shaped feathers of its tail are comparatively short and destitute of bars.

Lyric, the name given to a certain species of poetry because originally accompanied by the music of the lyre. It is rapid in movement, as befitting the expression of the mind in its emotional and impassioned moments, and naturally its principal themes are love, devotion, patriotism, friendship, and the Bacchanalian spirit. It was a favourite form among the ancient Greeks and Romans, and here it may be enough to mention the names of such masters as Sappho, Pindar, Tyrtaeus, Simonides, of many unknown writers in the *Greek Anthology*, and of Catullus and Horace. The most important form of the modern lyric is the *song*, with its religious sister, the *hymn*, neither of which, as we might expect, extends usually to any great number of lines. Lyric poetry obviously concerns itself with the thoughts and emotions of the writer's own mind, and is thus *subjective* as opposed to the epic, for example, which is essentially *objective* in character; while from beginning to end it should express but one incident, situation, or spasm of emotion. Modern English literature is remarkably rich in poetry in lyric forms, although it would be difficult to bring together any three of their contemporaries to outweigh Goethe, Schiller, and Heine. As admirable examples of devotional lyrics may be named Milton's 'Christmas Ode,' Byron's *Hebrew Melodies*, Moore's *Sacred Melodies*, and our thousand hymns of greater or less poetic value; of love-songs, the masterpieces of Herrick and other Caroline lyricists, and of Burns, the best dozen of whose songs stand safely first in their order, as well as, in later times, the unmatched utterances in Tennyson's *Maud* of the love-passion in its swift progress from hope to despair; of loyal, and patriotic, and martial lyrics, the Royalist, and especially the Jacobite group, Campbell's 'Ye Mariners of England,' 'Hohenlinden,' and 'The Battle of the Baltic,' Burns's 'Scots wha hae,' Byron's 'Isles of Greece,' and Tennyson's 'Charge of the Light Brigade' and 'The Last Fight of the Revenge.' An admirable selection from the whole range of English poetry is Palgrave's *Golden Treasury* (1861, often reprinted). See **SONG**.

Lys, or **LEYE**, a tributary of the Scheldt, rises in France near the little town of Lysbourg, in the department of Pas-de-Calais, and flows in a north-eastern direction, joining the Scheldt at Ghent in Belgium after a course of 130 miles.

Lysander, a famous Spartan warrior and naval commander, of extraordinary energy and military skill, but not less remarkable for the cunning, revenge, and ambition by which he was characterised. He spent part of his youth at the court of Cyrus the Younger, and in 407 B.C. was appointed to the command of the Spartan fleet, from which time he constantly prosecuted the design of overthrowing the Athenian power, in order to exalt that of Sparta. He defeated the Athenian fleet at the promontory of Notium; and, being again entrusted with the management of the fleet after the defeat of his successor, Callieratidas (405 B.C.), he was again victorious. He swept the southern part of the Ægean, and made descents upon both the Greek and the Asiatic coasts. He then sailed north to the Hellespont, and anchored at Lampsaenus. An immense Athenian fleet soon made its appearance at Egospotami, on the opposite side of the straits, amounting to 180 ships. Of these, 171 were captured by Lysander a few

days after. The blow to Athens was tremendous. Everywhere her colonial garrisons had to surrender, and Spartan influence predominated. Finally, in 404 B.C., he took Athens itself. His popularity now became so great, especially in the cities of Asia Minor, that the Spartan ephors dreaded the consequences, especially as they knew how ambitious he was. Every means was taken to thwart his designs, until finally it would appear that he had resolved to attempt the overthrow of the Spartan constitution; but this scheme was prevented by his death at the battle of Haliartus in the Boeotian war (395 B.C.). His life was written by Plutarch and by Cornelius Nepos.

Lysias, the first Greek orator who attained perfection in his own line, was the son of Cephalus, who, foreigner though he was—he came from Syracuse—succeeded in making his house one of the centres of intellectual life in Athens. Lysias himself was born in Athens, probably about 432 B.C. (the date is very uncertain), was educated along with children of the best Athenian families, and at fifteen years of age joined the colony planted by Athens at Thurii, where his early manhood was spent. The failure of the Athenian expedition against Sicily made it advisable for Lysias, like other friends of Athens, to leave Thurii, and in 412 he returned to Athens and continued his rhetorical studies, not for professional purposes, for he and his brother Polemarchus were wealthy, but from choice. The choice proved in the event a wise one, for the Thirty Tyrants, in 404 B.C., stripped the brothers of all their wealth, killed Polemarchus, and only failed to kill Lysias because he fled to Megara. The first practical use to which Lysias put his eloquence was, on the fall of the Thirty (403), to avenge his brother's death by prosecuting Eratosthenes, the tyrant on whom the principal responsibility for the legal murder of Polemarchus rested. He then practised, until his death at the age of eighty, with singular success as a writer of speeches for persons engaged in litigation. According to Dionysius of Halicarnassus, he composed 233 such speeches, and only failed in two instances to secure a favourable verdict. From an examination of the thirty-four surviving speeches, we can see that Lysias is at all times and in all matters surprisingly and delightfully lucid in both thought and expression; he rarely indulges in a metaphor, he is always direct, and uses simple, commonplace language for his simple narrative and common-sense arguments. But though simple his narrative is never monotonous; it is lively, graceful, and entertaining. Another quality, which both contributed to his practical success and helps to place his speeches amongst the most entertaining of Greek literature, is his power of character drawing.

The first edition is Aldus' (1513); the best edition of the text, Teubner's; a school edition, Cobet's (Amst. 1863). Selections, with German notes by Frobergger and Rauchenstein. See Jebb's *Attic Orators*; and Blass, *Die Attische Beredsamkeit*.

Lyte, HENRY FRANCIS, hymn-writer, born at Ednam, near Kelso, 1st June 1793; in 1812 entered Trinity College, Dublin; took orders in 1815; and, his health having failed three years earlier, died at Nice, 20th Nov. 1847. His *Poems, chiefly Religious* (1833; reprinted as *Miscellaneous Poems*, 1868), *Memoir of Henry Vaughan* (1847), &c., are almost forgotten; but 'Abide with me,' 'Pleasant are thy courts,' and other hymns keep his memory green. See Life prefixed to his *Remains* (1850).

Lytham, a watering-place of Lancashire, on the north shore of the Ribbles estuary, 14 miles W. of Preston, and 7 S.S.E. of Blackpool. Pop. 4122.

Lythraceæ, a natural order of exogenous plants, chiefly herbs, and rarely shrubs or trees.

The order contains about 40 genera and upwards of 300 species, chiefly natives of the tropics; but a few are found in Europe and in North America. Astringent qualities are ascribed to some of the species. The order is well represented in Britain by the well-known Loosestrife (*Lythrum salicaria*), which grows abundantly on the margins of ponds and streams and in moist meadows, in some parts of the country imparting character to the landscape by its broad masses of purple flowers. The Henna (q.v.) of Egypt is produced by *Lawsonia inermis*, a plant of this order. The leaves of another (*Pemphis acida*) are said to be a common potherb on the coasts of the tropical parts of Asia. The leaves of *Annonia resinifera*, an East Indian aquatic plant, are very acrid, and are sometimes used as blisters. *Physalium floribunda*, a Brazilian tree of this order, growing about 30 feet high, furnishes the valuable rosewood (the American tulipwood) of commerce.

Lyttelton, GEORGE, LORD, son of Sir Thomas Lyttelton of Hagley, in Worcestershire, was born in 1709, and educated at Eton and Christ Church, Oxford. He entered parliament in 1730, where he soon acquired eminence as a speaker, held several high political offices, was raised to the peerage in 1759, and died 22d August 1773. Lyttelton had once a considerable reputation as an author, and his poetry gained him a place in Johnson's *Lives of the Poets*. His best-known prose works are *Observations on the Conversion and Apostleship of St Paul* (1747), *Dialogues of the Dead* (1760), and *History of Henry II.* (1764). See his *Memoirs and Correspondence* (2 vols. 1845).—His son, THOMAS, LORD LYTTELTON (1744–79), who was as conspicuous for profligacy as his father for virtue, died three days after a nocturnal warning by a dove and a white lily (Chambers's *Book of Days*, vol. ii. p. 625). The *Poems by a Young Nobleman* (1780) may partly at least have been his, but the *Letters of the late Lord Lyttelton* (2 vols. 1780–82) were probably by Combe ('Dr Syntax'). A *Quarterly* reviewer (1851) identified him with Junius.

Lyttelton, SIR THOMAS. See LITTLETON.

Lytton, EDWARD BULWER, LORD, novelist, playwright, essayist, poet, and politician, was born at 31 Baker Street, London, on 25th May 1803. He was the third and youngest son of General Earle Bulwer (1776–1807) of Heydon and Dalling in Norfolk, by Elizabeth Barbara Lytton (1773–1843), the heiress of Knebworth in Hertfordshire. As a child a devourer of books, his favourites *Annals de Gaul* and the *Fairy Queen*, he took early to rhyming, and went to school at nine, though not, it may be unluckily, to a public one, but to six private tutors in succession (1812–21). In 1820 he published *Essays and other Poems*, and about the same time was 'changed for life' by a hopeless, tragic first love. At Trinity Hall, Cambridge (1822–25), he read English history, political economy, metaphysics, and early English literature; spoke much at the Union; carried off the Chancellor's gold medal for a poem upon 'Sculpture,' but took only a pass degree. Meanwhile, in a long-vacation walking-tour (1824), he had visited the grave of his lost love in the Lake Country; and there, in Scotland, and in the north of England, had strange adventures with cut throats and most impossible Gypsies. Now, his college life ended, he alternated awhile between Paris and London; and in London, in December 1825, he met Rosina Wheeler (1802–82), a beautiful Irish girl, whom in August 1827, despite his mother, he married. It was a most unhappy marriage. She bore him a daughter, Emily (1828–48), and a son, the future Earl of Lytton; in 1836 they separated. But his marriage did this

for him: it called forth a marvellous literary activity, for the temporary estrangement from his mother threw him almost wholly on his own resources. He had only £200 a year, and he lived at the rate of £3000; the deficiency was supplied 'out of his well-stored portfolio, his teeming brain, and his indefatigable industry.' During the next ten years he produced twelve novels, two poems, one political pamphlet, one play, the whole of *England and the English*, three volumes of *Athena, its Rise and Fall*, of which only two ever were published, and all the essays and tales collected in the *Student*, to which must be added his untold contributions to the *Edinburgh*, the *Westminster*, the *New Monthly* (of which he became editor in 1831), the *Economist*, &c. His Wertherian *Falkland*, published anonymously in 1827, gave little promise of the brilliant success, both at home and abroad, of *Pelham* (1828), the clever persiflage of whose dandy hero is still delightful. No two readers agree on the relative merit of his books, but indeed this very divergency of opinion as to which is really his masterpiece only illustrates his amazing versatility. Certainly *Pelham* is better than *Paul Clifford* (1830), a marvellous idealisation of the highwayman, as *Eugene Aram* (1832) is of the murderer; but most will rank it as inferior to the exquisitely fanciful *Pilgrims of the Rhoe* (1834) or to one or another of his four splendid historical novels—*The Last Days of Pompeii* (1834), *Rienzi* (1835), *The Last of the Barons* (1843), and *Harold* (1843). Then, there is his domestic trilogy, *The Caxtons* (1850), *My Novel* (1853), and *What will he do with it?* (1859), Sterne-like, yet strangely un-Sterne-like, surpassing Thackeray for peasants and Dickens for gentlemen, and both in knowledge of the world of politics. Or there are *Zanoni* (1842), *A Strange Story* (1862), and, shorter but stronger than either, *The Haunted* and *The Hunters* (*Blackwood's Magazine*, 1859). No English story of the supernatural comes near to this, and why?—because he wrote here as a believer, as a serious student of astrology, chiromancy, occult lore generally. These books are triumphs in the art of fiction in its most widely differing divisions, and taken together, display an unexampled range of powers. Here the reader finds at once vast knowledge, rich suggestiveness welded to profundity of thought, fresh insight into perplexing psychological and social problems, breadth of view, wit in richer measure than humour, together with an unusual power of handling vivid incident and a rare mastery of plot-construction.

Of his plays it must suffice to say that the *Lady of Lyons* (1838), *Richelieu* (1838), and *Money* (1840), all three of which owed something to hints from Maeready, still hold the stage as firmly as the masterpieces of Goldsmith and Sheridan; of his poems that *King Arthur* (1848), and even *St Stephens* (1860) and the *Last Tab of Miltus* (1866), will all be forgotten when the *New Timon* (1846) is still kept in remembrance by the savage answer it provoked from Tennyson.

In 1831, at the age of twenty-eight, he had entered parliament as member for St Ives, and attached himself to the Reform party; but Lincoln next year returned him as a Protectionist Liberal, and that seat he held till 1841. In 1838 the Melbourne administration conferred on him a baronetcy for his brilliant services as a pamphleteer; in Dec. 1843 he succeeded, by his mother's death, to the Knebworth estate, and assumed the additional surname of Lytton. He now sought to re-enter parliament, in 1847 contesting Lincoln unsuccessfully; and in 1852 he was returned as Conservative member for Hertfordshire. Deafness hindered him from shining as a debater, but he made himself a successful orator. In the Derby

government (1858-59) he was Colonial Secretary, and signalised his brief tenure of office by calling into existence the two vast colonies of British Columbia and Queensland. In 1866 he was raised to the peerage as Baron Lytton. He died at Torquay on 18th January 1873, and was buried in Westminster Abbey.

Lord Lytton's works in all exceed sixty, and fill more than 110 volumes. To those already mentioned may be added *The Disowned* (1829), *Deveraux* (1829), *Godolphin* (1833), *Ernest Maltravers* (1837), *Alice* (1837), *Lilla and Calderon* (1838), *Night and Morning* (1841), *Poems and Ballads, chiefly from Schiller* (1844), *Lucretia* (1846), *Caetoniana* (1863), *The Coming Race* (anonymously, 1870), *Kentia Chillingly* (1873), *The Parisians* (1874), and *Pausanias the Spartan* (unfinished, 1876). The *Life, Letters, and Literary Remains of Lord Lytton* (vols. i. ii. 1883), by his son, comes down only to 1832, so must be supplemented by the political Memoir, also by the Earl of Lytton, prefixed to the *Speeches of Lord Lytton* (2 vols. 1874).

Lytton, EDWARD ROBERT, EARL OF, poet, diplomatist, and statesman, was born in Hertford Street, London, 8th November 1831, and was educated at Harrow and at Bonn. In 1849 he went to Washington as an attaché and private secretary to his uncle, Sir Henry Bulwer (q.v.); and subsequently he was appointed attaché, secretary of legation, consul or *chargé d'affaires* at Florence

(1852), Paris (1854), The Hague (1856), St Petersburg and Constantinople (1858), Vienna (1859), Belgrade (1860), Constantinople again (1863), Athens (1864), Lisbon (1865), Madrid (1868), Vienna again (1869), and Paris (1873). In that last year he succeeded his father as second Lord Lytton, and in 1874 became minister at Lisbon, in 1876 Viceroy of India, at the same time receiving the Grand Cross of the Bath. The chief events of his viceroyalty were the proclamation of the Queen as Empress of India at the grand Delhi durbār on 1st January 1877, and the outbreak in 1879 of the tedious and unpopular Afghan war. In 1880, on the fall of the Beaconsfield government, he resigned, and was made Earl of Lytton; in 1887 he was sent by Lord Salisbury as ambassador to Paris, and there he died 24th November 1891. His works, published mostly under the pseudonym of 'Owen Meredith,' include *Clytemnestra* (1855), a dramatic poem; *The Wanderer* (1859); *Lucile* (1860), a novel in verse; *Serbški pesme* (1861), translations from the Servian; *The Ring of Amasis* (1863), a prose romance; *Orral, or the Fool of Times* (1869); *Fables in Song* (1874); *Glenarvill* (2 vols. 1885), an epic of modern life; *After Paradise, or Legends of Esde* (1887); *Maanh* (1892); and *King Poppy* (1892). A selection from his Poems by Miss M. Betham-Edwards appeared in 1890.

M



the thirteenth letter in our alphabet, is ultimately derived from the hieroglyphic picture of an owl. In the capital letter M the two peaks are the lineal descendants of the two ears of the bird, retaining between them a not inapt representation of the beak, the first of the vertical strokes corresponding to the breast (see ALPHABET). In the script form *m* the central hanger represents the beak, on either side of which are two curves corresponding to the ears. When the symbol was taken over by the Phœnicians from the Egyptian hieratic the zigzags in the form *𐤎* were supposed to resemble ripples, and hence the letter received the name *mnm*, 'the waters,' and this name in the Greek alphabet became *mu*, owing probably to assonance with the name of the following letter *nu*. Our minuscule *m* is descended from the old Roman cursive, through the Irish semi-uncial and the Caroline minuscule.

The sound of *m* is defined as a labial of the nasal class; that is, if the vocal organs are placed in the position for pronouncing the labial *b*, and the breath is allowed to pass into the nose, the sound produced is that of *m*. Hence *a* has a great attraction for *b*, as in *lamb*, *nimble*, from A.S. *līm* and *nimol*, or in *umber*, from the Latin *numerus*. Sometimes *m* becomes *b*, as in *marble* from *marmor*. So also we find the two nasals, *m* and *n*, interchanging according to the nature of the contiguous consonants. Thus *n* changes to *m* before a labial, as in *imperator* for *inperator*, while *m* changes to *n* before gutturals and dentals, as in *conjure* and *concordia*, or in *ant* from O.E. *amete*, *ransom* from *reahmptionem*, and *count* from *computare*.

Maartens, MAARTEN, is the pen-name of J. M. M. van der Poorten-Schwarz, a Hollander, born in 1858, who, having spent part of his boyhood in England and been at school in Germany, was educated at a home university for law. He is known as the author of a series of powerful novels in nervous English, including *The Sin of Just Aveling* (1889), *A Question of Taste*, *God's Fool*, *The Greater Glory*, and *My Lady Nobody* (1895).

Maas. See MEUSE.

Maastricht. See MAESTRICHT.

Mab, 'the fairies' midwife,' who delivers men of dreams. Shelley in *Queen Mab* makes her queen of the fairies, a dignity really belonging to Titania, the wife of Oberon (q.v.). Mab's praises have been sung by Shakespeare, Ben Jonson, Herrick, Dryden, and other English poets.

Mabilion, JEAN, a learned Benedictine, born 23d November 1632, at St Pierre-mont, in Champagne. He studied at St Remy, in 1653 entered the Benedictine order, was placed in 1658 in the monastery at Corbie, in 1663 became keeper of the monuments at St Denis, and from 1664 worked, with stupendous erudition, in the abbey of St Germain des Prés at Paris. Here he died, 27th December 1707. He made many journeys into Germany and Italy for purposes of research. He aided

D'Achéry in the preparation of his vast historical collection, the *Spicilegium*; undertook an edition of the works of St Bernard (1667); and constructed a general history of his order, *Acta Sanctorum ordinis S. Benedicti in servitorum classis distributa* (9 vols. folio, 1668-1701). His classical work *De Re Diplomatica* appeared at Paris in 1681. Other works are *Œcœna Aulectæ* (1675-85), *Museum italicum* (1687-89), and *Annales ordinis S. Benedicti* (6 vols. folio, 1703-39). His posthumous works, including many letters, appeared at Paris (3 vols. 1724).

See Ruinart, *Vie de Jean Mabillon* (1709); Chavin de Malan, *Histoire de Dom Mabillon et de la Congrégation de Saint-Maur* (1843); Jadart, *Dom Jean Mabillon* (1879); and E. de Broglie, *Mabillon, 1664-1706* (1888).

Mabinogion. See HELGEST, and WALES.

Mablethorpe, a village on the coast of Lincolnshire, 13 miles by rail (1888) SE. of Louth, with hard and extensive sands, to which thousands of the working-classes of Leicestershire, Nottinghamshire, Derbyshire, Yorkshire, and Lancashire are carried every summer by cheap day-excursion trains. Close by is a submerged forest. Pop. 640.

Mably, GABRIEL BONNOT DE, elder brother of Condillæ (q.v.), born at Grenoble on 14th May 1709, studied at the Jesuit College in Lyons, and became secretary to the minister Cardinal Tencin, his uncle. But before many years had passed the two had quarrelled, and Mably gave himself up to a studious life. He died at Paris on 23d April 1785. He entertained a great admiration for the ancients, especially for the institutions of Sparta, and constantly illustrated his writings by the acts and lives of Solon, Phocion, Lycurgus, and Cato. In this department his chief books were *Entretiens de Phocion* (1763); *Parallèle des Romains et des François* (1740), in which the latter came off second best; and *Observations sur l'Histoire de la Grèce* (1766). His *De la Manière d'Ecrire l'Histoire* (1783) contains severe strictures on Hume, Robertson, Gibbon, Voltaire, and other historians. *Le Droit Public de l'Europe* (1748) was the outcome of his official life. See Guerrier, *L'Abbe de Mably* (1886).

Mabuse, JAN, whose real name was GOSSAERT, a Flemish painter, was born at Mauthouze (Mabuse) about 1470, and entered the painters' guild of St Luke at Antwerp in 1503. His life and work are divisible into two well marked sections. In the earlier portion, during which he dwelt mostly at Antwerp, his paintings—principally altarpieces—show that he studied Memling, Van der Weyden, and Quentin Matsys; their influence is especially apparent in an 'Adoration,' now at Castle Howard in Yorkshire, and in altarpieces at Seaway in England, and Tongerlo in Belgium. The most celebrated of his early pictures, a 'Descent from the Cross,' painted for the church of Middelburg in Holland, was burned in 1568. In 1508 Mabuse accompanied Philip of Burgundy to Italy, when he went to arrange the treaty of Cambrai. This set the fashion to subsequent Flemish painters of spending some time in the sunny, art-loving south. Mabuse returned home with his style greatly modified by the study of Leonardo, Michael Angelo, and Raphael; but the modification was

one that too often tended towards mannerisms, and to the introduction of contemporary portraits and details into religious pictures. After his return he resided chiefly at Wyck, Middelburg, and Antwerp, and died at the last named place on 1st October 1532. His later works embrace three classes—subjects from Greek mythology, as Neptune and Amphitrite, and Danae, characterised by strong traits of coarse realism; portraits, as of the children of King Christian II. of Denmark (about 1528), of a princess of Portugal, and of Jean Carondelet (1517); and religious subjects, including 'St Luke painting the Madonna,' 'Christ in Agony,' 'Adam and Eve,' and several Madonnas. Mabuse was a painstaking workman. Nearly all his pictures have rich architectural backgrounds, but the figures are stiff and stony; the colours are bright, sometimes gaudy.

Mac (contracted M'), a Gaelic prefix occurring frequently in Scottish names, as Macdonald, McLennan, and the like, meaning 'son.' It corresponds to the *son* in names of Teutonic origin, as Davidson; the *Fitz* in Norman names, as Fitzherbert; the Irish *O*, as in O'Connell; and the Welsh *Map*, shortened into 'ap' or 'p,' as Ap Richard, whence Prichard.

Macadam, JOHN LOUDON, inventor of the system of road-making known as 'macadamising,' the son of James MacAdam of Waterhead of Dugh, Kirkeudbright, was born at Ayr, 21st September 1756. He went to New York in 1770, entered his uncle's counting-house, became a successful merchant, and on his return to Scotland in 1783 bought the estate of Sauchie, Ayrshire. He began in 1810 to make experiments in the construction of roads, which became a passion with him, and in gaining experience he travelled 30,000 miles, and spent £3000. In 1816 he was appointed surveyor to the Bristol Turnpike Trust, and re-made the roads there cheaply and well. His advice and assistance were now sought in all directions, and his methods formed the subject of a select committee of the House of Commons in 1819. Instead of going deep for a 'bottoming,' he worked on the top; the road-metal, from 1 to 2 ounces in size, was scattered to a depth of from 6 to 10 inches, and when shaken and pressed together, made a top covering as close as a wall (see ROAD). Macadam, impoverished through his labours, petitioned parliament in 1820 for his expenses and some reward. His petition was repeated in 1823, and he was voted £10,000 and appointed Surveyor-general of Metropolitan Roads in 1827. He declined a knighthood. He died at Moffat, Dumfriesshire, 26th November 1836. He published *A Practical Essay on the Successful Repair and Preservation of Public Roads* (1819), *Remarks on the Present State of Road-making* (1820), and *Observations on Roads* (1822).

McAll Mission, the largest Protestant mission in France, was founded in 1871 by the Rev. Robert Whitaker McAll (born 1821, died 1893; see the *Life* published in 1896) and his wife. It now possesses more than 100 stations (some 40 in Paris), and is supported by Protestant Christians of all denominations in Britain and the British colonies, and the United States. Twelve years after its foundation, the mission held within the year 15,000 meetings, attended by close on a million of persons (mainly of the most neglected and irreligious classes), paid 20,000 house-to-house visits, and distributed more than 500,000 Bibles and tracts.

Macao, a Portuguese settlement on the south coast of China, on the west side of the estuary of the Canton River, Hong-kong being about 40 miles distant on the opposite side of the same estuary. The settlement occupies a small peninsula projecting from the south-eastern extremity of the island

of Hiang-shang, and is defended by forts built on the high ground overlooking the town. The islands Colovane and Taipa also belong to the settlement, whose total area is $4\frac{1}{2}$ sq. m. and pop. close upon 70,000, of whom less than 5000 are Portuguese, the rest being mostly Chinese. The principal public buildings are the cathedral and churches. Macao is one of the healthiest ports in China, though the heat is excessive during the south-west monsoon. The greater part of the revenue of the settlement is derived from licensed gambling-houses. The Portuguese obtained permission from the Chinese authorities to settle in Macao in 1557. The Chinese, however, until 1886 exacted from them an annual ground-rent, and retained jurisdiction over their own people. The anchorage of the port is defective; large vessels cannot approach nearer than six miles. Since the rise of Hong-kong the commerce of Macao has suffered severely. Shortly after it was declared a free port (1845) it became the headquarters of the coolie trade, especially with Peru and Cuba; but in consequence of fearful abuses the British and the Chinese constrained the Portuguese government to abolish the traffic in 1873 (see COOLIES). The trade of Macao (the name of which was for long a synonym for stagnation and decay) showed, in 1885-90, some signs of reviving. The import trade, mainly in the hands of Chinese and Parsees, had in 1889 a value of £755,057, the chief item being Patna opium; other imports are kerosene (formerly from America, now largely from Batavia), piece goods, yarn, and provisions. The exports, valued at £716,755 in 1889, comprise tea, oils, silk, and rice. The export of tea from Macao to London alone was 2,500,000 lb. British merchants have a share of the export trade, but not the Portuguese. Macao is the seat of a bishop and the headquarters of French missions in China. A grotto is shown here in which Camoens (q.v.) is traditionally believed to have written his *Lusiad* during his banishment.

Macaroni (originally lumps of paste and cheese squeezed up into balls; from Ital. *maciare*, 'to bruise or crush'), a peculiar manufacture of wheat which for a long time was confined to Italy, and, in fact, almost to Genoa; it is now, however, made all over Italy and at Marseilles and other places in the south of France. Strictly speaking, the name macaroni applies only to wheaten paste in the form of pipes, varying in diameter from an ordinary quill up to those now made of the diameter of an inch; but there is no real difference between it and the fine threadlike vermicelli, and the infinite variety of curious and elegant little forms which, under the name of *Italian pastes*, are used for soups. Only certain kinds of wheat are applicable to this manufacture, and these are the hard sorts which contain a large percentage of gluten. The wheat is first ground into a coarse meal, from which the bran is removed. This 'semola' is worked up into a dough with water; and for macaroni and vermicelli it is forced through gauges, with or without mandrels, as in wire and pipe drawing; or for *pastes* it is rolled out into very thin sheets, from which are stamped out the various forms of stars, rings, &c. Macaroni forms a large article of home consumption, and is exported to all parts of the world.

Macaronic Verse is properly a kind of humorous poetry, in which, along with Latin, words of other languages are introduced with Latin inflections and construction; though the name is sometimes applied to verses which are merely a mixture of Latin and the unadulterated vernacular of the author. Thus 'lassus kissare bonas' ('to kiss the bonnie lassies'), and 'burnantem extinguere thurstum,' are parts of macaronic hexameters.

Teofilo Folengo, called Merlinus Coccaius (1491-1554), a witty and graceless Benedictine, has been erroneously regarded as the inventor of macaronic poetry; but he was the first to employ the term in this sense. His *Macaronum* (1517) is a long satiric poem, in which Latin and Italian are mingled. A predecessor of his by half a century was Odassi or Odaxius of Padua. Good specimens are found in the *Mutule Imaginarie*, and in the *Epistole Obscurorum Virorum*. The *Polemio-Midlinia* (1683), ascribed to Drummond of Hawthornden, but rather by an obscure pamphleteer, Samuel Colvill (writing about 1680), is probably the best-known British example. Fortunately macaronic poetry has not been very extensively cultivated, although specimens of it may be found in the literature of almost all European countries.

See Genthe, *Geschichte der Macaronischen Poesie* (1829); Octave Délepière's *Macaroniana* (1852), and his *De la Littérature Macaronique* (1856); Morgan's *Macaronic Poetry* (New York, 1872); Brunet's *Littérature Macaronique* (1879); and Portior's *Opere Macaroniche di Merlino Coccaio* (3 vols. Mantua, 1882-89).

Macaroon (from the same root as Macaroni), a kind of biscuit made with the meal of sweet almonds instead of wheaten or other flour.

Macartney, GEORGE MACARTNEY, EARL, an administrator and diplomatist, was born of Scottish descent at Lissanore, near Belfast, Ireland, on 14th May 1737. On leaving Trinity College, Dublin, he entered (1759) the Inner Temple, London. As envoy-extraordinary to Russia, he concluded (1767) a commercial treaty; from 1769 to 1772 he was Chief-secretary of Ireland; and from 1775 to 1779 he was governor of Grenada, in the West Indies, but was compelled, after an honourable defence, to give up the island to Count D'Estaing, and was himself carried prisoner of war to France, though he soon contrived his exchange. The East India Company in December 1780 appointed him governor of Madras, and six years later promoted him to be governor-general; but his weak state of health obliged him to decline the honour. He had already had some experience as member of both the English and the Irish parliaments, and had been raised from a knight (created in 1764) to a baron in Ireland (1776). A duel with an officer named Stuart, whom he had expelled the service in India, brought him a severe wound shortly after his return home from India. The first diplomatic mission to China from Great Britain was headed by Macartney, now an Irish viscount, in 1792; before his return home he was made an Irish earl (1st March 1794). After undertaking a confidential mission to Italy (1795-96), he went out as governor of the new colony of the Cape of Good Hope (1796); but ill-health compelled him to return home in November 1798. Three years later he was offered a place in the Addington ministry, but he declined the honour. He died at Chiswick on 31st March 1806. In 1796 he was made Baron Macartney in the British peerage. See *Life*, prefixed to (Sir) J. Barrow's edition of his *Redeings* (1807).

Macassar, the most southern portion of Celebes, contains the chief town and port, Macassar, on the west coast of the southern peninsula, with a pop. of 20,000. See *CELLERES*.

Macaulay, THOMAS BABINGTON, LORD, one of the most popular and brilliant of British essayists and historians, was born at Rothley Temple, Leicestershire, 25th October 1800. He came of a Scottish Celtic family, several of whose representatives were ministers of the Church of Scotland. Two of them—Macaulay's grandfather, John Macaulay, who died minister of Cardross, and Kenneth, author of a history of St Kilda, came

into contact and collision with Samuel Johnson, when touring in the H-brides in the company of Boswell. Zachary Macaulay (1768-1838), the father of the future historian and politician, had a somewhat chequered career as an estate manager in Jamaica, but in the later years of his life was best known as an energetic and single-hearted member of the 'Clapham Sect' of philanthropists of which Wilberforce was the acknowledged head. He was married in Bristol in 1799 to Selina Mills, the daughter of a Bristol Quaker, and the pupil and friend of Hannah More. Macaulay was the first off-spring of this union, and was named after his father's brother-in-law. His earliest years were spent with his family in London. From infancy he showed that insatiable thirst for knowledge, that prodigious tenacity of memory, and that talent for phrase-making, which were subsequently to be the delight and the envy of his contemporaries. At the age of seven he wrote a compendium of Universal History and three cantos of the 'Battle of Cheviot' in imitation of Sir Walter Scott. His parents while noting marks of uncommon genius in their son, and encouraging him in every way, never flattered him or paraded him before others as a prodigy. Thus he grew up a simple child delighting in, but unconscious of his faculty, 'playful as a kitten,' and devoted to his brothers and sisters. In 1812 he was sent to a private school kept by the Rev. Mr Preston, a Low Church clergyman, at Little Shelford, near Cambridge. There, and at Aspenden Hall in Hertfordshire, to which Mr Preston removed in 1814, he remained till his time came to go to college. He studied hard and read omnivorously; the taste for novels and light literature generally which he now acquired and never lost, brought him more than one rebuke from his father.

In October 1818 Macaulay went into residence at Trinity College, Cambridge; but he detested mathematics, and cannot be said to have distinguished himself as a student. Yet he twice won the Chancellor's medal for English verse, and obtained a prize for Latin declamation. In 1821 he carried off a Craven university scholarship; took the degree of B.A. the following year; and in 1824 was elected to a Fellowship. He was one of the most brilliant disputants in the Union Debating Society, and made the friendship of the ablest of his contemporaries, including Praed, Romilly, Charles Villiers, Moultrie, and above all Charles Austin.

In 1826 Macaulay was called to the bar and joined the Northern Circuit. But he had no liking for his nominal profession, and made no attempt to secure a practice. Already, indeed, literature had irresistible attractions for him. In 1823 he became a contributor to *Knight's Quarterly Magazine*, along with Praed and others of his Cambridge friends. In it there first appeared some of his best verses—in particular *Lucy*, *The Spanish Armada*, and *Nashby*. Certain of his prose articles, such as *The Fragment of a Roman Tale*, and *Scenes from the Athenian Revolt*, 'show,' says Cotter Morison, 'such a natural turn for a dialogue and dramatic *mise en scene*, that it says a great deal for Macaulay's good sense and literary conscientiousness that he remained content with this first success, and did not continue to work a vein which would have brought him prompt, if ephemeral popularity.' In 1825 the year in which he took his degree of M.A.—he was discovered by Jeffrey, then on the outlook for 'some clever young man' to write for the *Edinburgh Review*. The famous article on Milton appeared in the August number, and the unequivocal success which it met with not only secured him a position in literature, but was the means of opening to him the doors of society

and politics. But Macaulay's first thoughts were for his family. It was now in straitened circumstances, owing chiefly to his father being too much absorbed by the agitation for the abolition of the slave trade to attend to his business. Macaulay ungrudgingly took upon himself the task of supporting his brothers and sisters by his pen. Fortunately it was now in great demand. For nearly twenty years he was one of the most prolific of the writers to the *Edinburgh Review*, and out of sight the most popular. Macaulay was, however, claimed by politics. Certain of his articles had attracted the attention of the chiefs of the Whig party to which he had attached himself. In 1830 he entered parliament, having been presented by Lord Lansdowne with the pocket-borough of Calne. He threw himself with his usual intensity into the work of the House of Commons, and in his first session made a speech in favour of the bill for the removal of Jewish disabilities. But it was in the debates that preceded the passing of the Reform Bill that his great powers as an orator were in reality first manifested. While devoting himself to parliament, rivalling Stanley in debate and Hume in the regularity of his attendance, he discharged the duties first of Commissioner, and then of Secretary, to the Board of Control. At the same time he wrote steadily for the *Edinburgh Review*, and made almost as great a reputation as a conversationalist in society as he had already acquired as a parliamentary debater.

On the passing of the Reform Bill of 1832, Macaulay had exchanged Calne for Leeds. Mainly for the sake of his family he accepted the office of legal adviser to the Supreme Council of India, with a salary of £10,000 a year attached to it. Accompanied by his favourite sister Hannah, who in Dec. 1834 married Mr (afterwards Sir) C. Trevelyan, he sailed for Calcutta (by Madras), Feb. 15, 1834. In India he worked as hard as he had done in England. Besides discharging his duties as member of the Supreme Council, he acted as chairman of two committees—the committee of Public Instruction, and the committee appointed to prepare a Penal Code and a Code of Criminal Procedure. In the former capacity he drew up an elaborate minute, in which he successfully counselled the teaching of European literature and science to the natives of India. To Macaulay also must be assigned the lion's share of the great work performed in connection with the Indian Penal Code, of which Sir James Fitzjames Stephen has said: 'It is to the French Code Penal, and I may add the North German Code of 1871, what a finished picture is to a sketch. It is far simpler and better expressed than Livingstone's Code of Louisiana, and its practical success has been complete.' For a time Macaulay was extremely unpopular with a section of the British population of Calcutta, owing to the active part he took in bringing about a judicial reform known as the Black Act, which withdrew from British subjects resident in the provinces of India the privilege of bringing civil appeals before the Supreme Court of Calcutta. During his stay in India he read enormously, and wrote for the *Edinburgh Review* his essays on Mackintosh and Bacon. In the beginning of 1838 he returned to England with the competence he had saved from his official salary.

After a pleasant tour in Italy, Macaulay returned to political life, though not without reluctance, as he was already laying the foundations of his great historical work. In 1839 he was elected member for Edinburgh, and the year following entered Lord Melbourne's cabinet as Secretary at War. His most important work at this time was the writing of *The Lays of Ancient Rome*, which had been partially inspired by his visit to Italy. Never has

purely civic patriotism received a more spirited poetic rendering than in this volume. It appeared in 1842, and won an immense popularity. Next year he published his collected *Essays* in three volumes. While his party were in opposition, he delivered a number of weighty speeches in the House of Commons on subjects which interested him. By one of these he converted Sir Robert Peel, and indeed the majority of the House, to his views of copyright; in another he declared, 'Of all the institutions of the civilised world, the Established Church of Ireland seems to me the most absurd.' His connection with the *Edinburgh Review* ceased in 1845; he had now commenced his *History of England from the Accession of James II.* When Sir Robert Peel's administration fell in 1846, Macaulay took the office of Paymaster-general of the Forces, and was re-elected triumphantly for Edinburgh. A variety of circumstances, however, of which probably the support he had given in parliament to the Maynooth Grant, was the chief—led to his defeat at the general election of the following year.

Macaulay regarded this defeat as a signal for his retirement into private life. In 1852 he was again returned for Edinburgh without any exertion on his own part; but he made few speeches after his reappearance in parliament, and gave himself up almost entirely to his *History*. The first two volumes appeared in 1848, and at once attained a greater amount of popularity than had ever before fallen to the lot of a purely historical work (see LONGMAN). Next year he was elected Lord Rector of the university of Glasgow. He had a severe illness in 1852, and from this he never completely recovered. In 1855 the third and fourth volumes of his great work were given to the public, and were as cordially received as their predecessors. The following year he retired from the representation of Edinburgh. In 1856, also, he left the bachelor chambers he had occupied for fifteen years in the Albany, and took up his residence in Holly Lodge, Campden Hill, Kensington, where he lived till his death. In 1857 he was raised to the peerage under the title of Baron Macaulay of Rothley. In the same year he was elected a foreign associate of the French Academy of Moral and Political Sciences. Among other honours which came to him in his last years, and which he especially prized, was his nomination to the Prussian Order of Merit, and his election to the High Stewardship of the borough of Cambridge. While working steadily at his *History*, he found time to write for the *Encyclopædia Britannica* articles on Atterbury, Bunyan, Goldsmith, Samuel Johnson, and William Pitt. Though conscious that the ailment from which he suffered—weakness of the heart, complicated with asthma—would prove fatal, he took as keen an interest as before in the well-being of his relatives and in the fortunes of his country. The end came on the 28th December 1859; he died as he had always wished to die—without pain, without any formal farewell; proceeding to the grave all whom he loved, and leaving behind him a great and honourable name, and the memory of a life, every action of which was as clear and transparent as one of his own sentences. He was buried in Poet's Corner, Westminster Abbey, on 9th January 1860. The fragmentary fifth volume of his *History* which he left behind him was published in 1861.

The reputation of Macaulay is certainly not what it was during his lifetime or immediately after his death. He has been convicted of historical inaccuracy, of sacrificing truth for the sake of epigram, of allowing personal dislike and party bias to distort his views of men and incidents. He looks too much at the mere material side of life. As a

thinker he is deficient in balance, repose, inwardness, and modesty. In his writing there is far too much light and far too little shade; he not infrequently confounds the foaming hurry of his own words with the march of events; the splendour of his style sometimes degenerates into garishness; occasionally when he plays the censor, he almost sinks into insolent brutality. It must be admitted also that he was too declamatory to be accorded a place in the front rank either of poets or of historians. But as a narrator of events he has no rival, and hardly even a second; he is lucidity itself. The intellectual solidity and energy of Macaulay, the breadth and variety of his knowledge, the fervour and dignity of his patriotism—these remain untouched by posthumous criticism. And in his nephew's biography he stands revealed as the most affectionate and unselfish of relatives, loyal in his friendships, pure-minded as a child, generous, upright, and courageous. Of no public man, of no man of letters, can the nation be more whole-heartedly proud than of Macaulay.

The authoritative work on the life of Lord Macaulay is the *Life and Letters*—a most admirable biography—by his nephew, Sir George Otto Trevelyan, the first edition of which was published in 1876. A Life of his father by Viscountess Kintford appeared in 1900. Of the innumerable estimates of Macaulay which have appeared since his death, Cotter Morison's Monograph in the 'English Men of Letters' series (1882), an essay by Mr John Morley (*Critical Miscellany*, 1886), and an elaborate study by M. Taine (*History of English Literature*, vol. ii, 1871) may be mentioned.

Macaw. See PARROT.

Macaw-tree, GREAT (*Acrocomia sclerocarpa*), a palm of the same tribe as the cocoa-nut, a native of the West Indies and of the warm parts of America. It is called *Macaoya* in Guiana and *Mucabuba* in Brazil. It is from 20 to 30 feet high, with pinnated leaves from 10 to 15 feet long. The fruit yields an oil of a yellow colour, of the consistency of butter, with a sweetish taste, and an odour of violets, used in the native regions of the tree as an emollient in painful affections of the joints, and extensively imported into Britain, where it is sometimes sold as *Palm Oil*, to be used in the manufacture of toilet-soaps.

Macbeth, hereditary *normann* or ruler of Moray, married Gruoch, granddaughter of Kenneth III, king of Alban. In 1040 he slew Duncan, king of Scotia, near Elgin, and succeeded him on the throne, though to Thorfinn, the Norwegian earl of Orkney, he had to yield the region north and east of the Tay, and Cumbria and Lothian seem to have remained faithful to Duncan's infant sons. His seventeen years' reign is commemorated in the chronicles as a time of plenty. He granted lands to the Culdees of Locheleven 'with the utmost veneration and devotion; and, alone of Scottish kings, he made a pilgrimage to Rome (1050), and there gave large alms to the poor. Malcolm Canmore, King Duncan's eldest son, had fled to England on his father's death; and in 1054 his uncle Siward, Earl of Northumbria, led an army into Scotland against Macbeth. A bloody but indecisive battle was fought near Scone; and it was not till three years later that Malcolm, making a fresh independent attempt, drove Macbeth into Aberdeenshire, and killed him at Lumphanan, 15th August 1057. Such practically is all that is known for certain of the 'liberal king,' as St Berchan styles Macbeth. The fables immortalised by Shakespeare's genius have for pedigree Raphael Holinshed, out of Hector Boece, out of Boece's fertile fancy and Wyntoun. See Skene's *Celtic Scotland* (1876).

Maccabees, a word of uncertain meaning and origin, but the name Makkabi, originally given to Judas Maccabeus, is possibly connected with

Mappab, 'hammer.' The founder of the Maccabean dynasty, Matithjahu, or Mattathias, a priest (not, as generally supposed, a high-priest, nor even of the family of high-priests), was the first who made a stand against the persecutions of the Jewish nation and creed by Antiochus Epiphanes. He and his family were called Hasmonæans (Gr. *Asamoniæi*). At the beginning of the troubles he had retired, together with his five sons, Jochanan, Simon, Jehmdah (Makkabi), Eleazar, and Jonathan, to Modiin, a small place between Jerusalem and Joppa, to mourn in solitude over the desolation of the holy city and the desecration of the Temple. But the Syrians pursued him thither. He being a person of importance, Apelles, a Syrian captain, endeavoured to induce him, by tempting promises, to relinquish his faith, and to embrace the Greek religion. He answered by slaying with his own hand the first renegade Jew who approached the altar of idolatry. This gave the sign for a sudden outbreak. His sons, together with a handful of faithful men, rose against the national foe, destroyed all traces of heathen worship, and fled into the wilderness of Judah. Their number soon increased; and not long after, they were able to make descents into the adjacent villages and cities, where they circumcised the children, and restored everywhere the ancient religion of Jehovah. At the death of Mattathias (166 B.C.), which took place a few years after, Judas Makkabi (166-161 B.C.) took the command of the patriots, and repulsed the enemy, notwithstanding his superior force, at Mizpah, Beth-sur, and other places, reconquered Jerusalem, purified the Temple, and re-inaugurated the holy service (164 B.C.). Having further concluded an alliance with the Romans, he fell in battle against Bacchides (161 B.C.). His brother Jonathan, who succeeded him in the leadership, renewed the Roman alliance, and taking advantage of certain disputes about the Syrian throne, rendered vacant by the death of Antiochus, acquired the dignity of high-priest. But Tryphon, the guardian of the young Prince Antiochus Theos, fearing his influence, invited him to Ptolemais, and had him there treacherously executed. Simon, the second brother, was elected by the Jewish commonwealth to assume the reins of the national government, and was formally recognised both by Demetrius, Tryphon's antagonist, and by the Romans as 'chief and ruler of the Jews.' He completely re-established the independence of the nation, and the year after his succession (141 B.C.) was made the starting-point of a new era. The almost absolute power in his hands he used with wise moderation; justice and righteousness flourished in his days, and 'Judah prospered as of old.' But not long (seven years) after his accession to the supremacy, he was foully murdered (136 B.C.) by his own son-in-law, Ptolemy, who vainly hoped to succeed him. For the subsequent history of this family, see JEWS, HYRCANUS, and HEROD. The Feast of the Maccabees—i.e. both of the sons of Mattathias, and of the seven martyr children (2 Macc. vii.)—is found in the Roman martyrology under the date of the first of August. See De Sauley, *Histoire des Maccabees* (1880); Ewald, and Schurer.

Maccabees, BOOKS OF. Two books of this name are recognised as canonical by the Church of Rome, and enumerated in the articles of the Church of England among those apocrypha which 'the church doth read for example of life and instruction of manners, yet doth not apply to establish any doctrine.'

1. *Maccabees*, by far the more important of the two, after a rapid account of the conquests of Alexander the Great and the distribution of his dominions among his successors (i. 1-9), goes on to describe

the Hellenising policy of Antiochus Epiphanes towards the Jews and its baneful effects (i. 10-61). Chapter ii. gives the genealogy of the Maccabean family and an account of the efforts of the aged Mattathias to rouse the spirit of active resistance among his countrymen (168 B.C.). The rest of the book falls into three main divisions, relating respectively to Judas (iii. 1 ix. 22), Jonathan (ix. 23 xii. 53), and Simon (xiii. 1 xvi. 18), the sons of Mattathias, and concludes with a brief mention of the accession of John Hyrcanus, referring for details to 'the chronicles of his priesthood' (xvi. 19-24). The work as we now possess it is the Greek translation of a Hebrew original, which was still extant in Jerome's time. According to Origen its Hebrew title was *Sepherth Sabaniel* (meaning, perhaps, 'the prince of the house which God built up'). The date of its original composition cannot have been much (if at all) earlier than 106 B.C. (the last year of Hyrcanus), nor later than 64 B.C., at which time the relations of the Jews with the Romans changed so greatly for the worse. The author was plainly a Hebrew-speaking Jew, well acquainted with the topography of Palestine, who, if he had not actually witnessed or taken part in some of the transactions he describes, had at least conversed with those who had, and been at pains to make himself acquainted with the authentic oral traditions regarding them. He also had access to written documents, some of them of a public and official character. In spite of some inaccuracies and exaggerations he is entitled to high rank as a sober, painstaking, and trustworthy historian. The date of the Greek translation cannot be determined, but it was probably made very soon after the appearance of the original. 1 Maccabees was translated by Luther, who speaks of it as almost on a level with the canonical books, and hardly unworthy to be reckoned among them.

2 Maccabees opens with two letters (i. 1-9 and i. 10-ii. 18), purporting to be addressed by the Jewish authorities in Jerusalem to their brethren in Egypt, urging them to the regular observance of the Feast of the Dedication. The second and longer of the two contains much legendary and fabulous matter about Jeremiah and Nehemiah, and on the internal evidence generally it seems certain that both must be regarded as spurious. The reference in these letters to the wars of liberation leads the author of the book to speak of Judas Maccabeus, and to introduce himself as the epitomator of the five books of Jason of Cyrene on this theme. Who Jason of Cyrene was, or at what date he lived, is not known; he wrote in Greek, at some distance, both in place and in time it would seem, from the events he describes. He does not appear to have been acquainted with 1 Maccabees. The date of his epitomator is also uncertain; all that can be said with certainty is that it must have been prior to the destruction of Jerusalem in 70 A.D. In numerous instances the statements of 2 Maccabees do not admit of reconciliation with those of 1 Maccabees, and the result of critical examination is in every case in favour of the latter. It is evident that the epitomator, at least, if not also Jason himself, was comparatively indifferent to rigid accuracy in historical detail; he writes mainly with a didactic purpose, and seeks at every point to give prominence to supernatural interventions on behalf of the chosen nation.

Besides the above comparatively well-known writings, there occur in certain MSS. of the Septuagint two other books known also by the name of Maccabees, though called so only in a loose sense.

3 Maccabees, in seven chapters, relates two occurrences in the reign (222-205 B.C.) of Ptolemy IV. Philopator: his attempt to desecrate the Temple,

which was miraculously defeated through the prayers of Simon the high-priest, and the frustration of his vindictive scheme to destroy all his Jewish subjects, whom he had caused to be gathered together in the circus at Alexandria. The narrative is in many parts obviously fabulous, and at every point is without historical confirmation.

4 Maccabees, as its original title, 'On the Sovereignty of Reason' implies, is a discourse on the sovereignty of pious reason over the passions (i. 1-iii. 18); to this are appended numerous illustrations from the time of the Maccabees (iii. 19-xviii. 23). The second and larger portion may possibly have been based on the work of Jason of Cyrene (see above); the work as a whole is of a hortatory character, and the suggestion has been made that it was originally a synagogue sermon. Of the author nothing is known except that he was a sincere Jew, well read in Greek philosophy, and especially in that of the Stoics.

A fifth book of Maccabees, in Arabic, is printed in the Paris and London polyglots. It gives a summary of Jewish history from 180 B.C. to the close of the reign of Herod the Great, but has no independent value.

The best edition of the text of the four books of Maccabees is that of Fritzsche (*Libri Apocryphi Veteris Testamenti Græci*, 1871), and the best commentary that of Grimm in the *Ecclésiastisches Handbuch* (1 Macc. 1853; 2-4 Macc. 1857). English translations are given in Cotton's *Five Books of Maccabees in English* (1832).

Maccaluba, a small mud volcano, 138 feet in height, situated 6 miles N. of Girgenti in Sicily. The sides are studded with numerous small cones, which usually emit hydrogen, and occasionally mud and stones, often sending them to a great height.

MacCarthy, DENIS FLORENCE, an Irish poet, was born in Dublin, 26th May 1817. He became known as one of the young poets of that famous newspaper, the *Nation*, founded by Charles Duffly in 1842, and his collected *Ballads, Poems, and Lyrics* appeared in 1850. His 'Bell-Founder,' 'Voyage of St. Brendan,' 'Foray of Con O'Donnell,' and the 'Pillar Towers of Ireland,' quickly carried his fame over the land as well as to Irishmen beyond the sea. Shelley's translations from Calderon attracted him to Spanish, and in 1853 he published six of Calderon's dramas translated in the metres of the original, and further instalments followed in 1861, 1867, 1870, and 1873, earning the praises of Ticknor and Longfellow, and in 1881 a medal from the Royal Academy of Spain. In 1872 appeared *Shelley's Early Life*, and in 1879 he wrote the ode for the Moore centenary. For some years MacCarthy suffered from heart disease, and he died at Blackrock, near Dublin, April 7, 1882. A collected edition of his poems appeared in 1884.

MacCarthy, JESSES, a brilliant journalist and novelist, born in Cork, 22d November 1830. He became attached to the staff of the *Northern Times*, Liverpool, in 1853, and in 1860 entered the reporters' gallery of the House of Commons for the *Morning Star*, becoming its foreign editor the following autumn and chief editor three years later. He resigned his post in 1868, and devoted the next three years to an unusually complete tour of the United States, in which he visited as many as thirty-five of the thirty-seven states. Soon after his return he became connected with the *Daily News*, but he has also contributed among other magazines to the *London*, the *Westminster*, and the *Fortnightly Review*. He entered the House of Commons in 1879 as member for Longford, and was leader of the main wing of the Irish Home-Rule party ('Anti-Parnellite') from the deposition of Mr. Parnell (q. v.) till 1896, when he resigned the post. Of his novels the best known are *Paul Massie*

(1866), *The Waterdale Neighbours* (1867), *My Ewan's Daughter* (1869), *Lady Judith* (1871), *A Fair Saxon* (1873), *Linley Rockford* (1874), *Dear Lady Disdain* (1875), *Miss Misanthropie* (1877), *Dunno Quicote* (1879), *The Comet of a Season* (1881), *Maid of Athens* (1883), *Camillo* (1885), and *The Right Honourable*, with Mrs Campbell Praed (1886). His other works are *Can Moore*, a collection of essays (1868); *Critical Notice of George Sand* (1870); *Prohibitory Legislation in the United States* (1872); *Modern Leaders*, biographical sketches (1872); and *A History of our Own Times, from the Accession of Queen Victoria* (4 vols. 1879-80; vol. v. 1897), an exceedingly readable work, clear and useful, though neither erudite nor exhaustive. Without professing to be impartial, the author is unprejudiced and is unexpectedly sane on Irish questions, which he expounds rather than discusses. His literary criticisms are not always happy. Later works are *The Epoch of Reform* (1882) and *History of the Four Georges* (4 vols. 1889 *et seq.*). See his *Reminiscences* (1899).

McHeyne, ROBERT MURRAY, who has been called 'the George Whitefield of Scotland,' was born at Edinburgh on 21st May 1813, educated at the High School and university of his native town, and licensed as assistant preacher in Larbert and Dunipace in 1835. The scene of his life-work was, however, Dundee; he was elected minister of the new church of St Peter's there in 1836, and laboured in the same parish until his death, on 25th March 1843. In 1839 he visited Palestine as one of a mission of four ministers sent out by the Church of Scotland to inquire into the condition of the Jews, and on his return published, in conjunction with A. A. Bonar, *Narrative of a Mission of Enquiry to the Jews* (1839). He died on the very eve of the Disruption; had he lived he would certainly have thrown in his lot with the party of his former tutors, Dr Chalmers and Dr Welsh. Besides being an eloquent preacher, a man of saintly piety, and a most exemplary parish minister, McHeyne wrote hymns and published sermons, both of considerable merit. See his *Remains* (*Letters, Sermons, &c.*), with a Memoir by A. A. Bonar (1848; 129th thousand, 1881). His *Complete Works* appeared at New York in 2 vols. in 1847.

Macchiavelli. See MACHIAVELLI.

McClellan, GEORGE BRINTON, an American general, was born at Philadelphia, 31 December 1826, graduated at West Point with 'Stonewall' Jackson and others in 1846, and served with the engineers through the Mexican war, where repeated gallantry in action gained him a captain's brevet. He was afterwards employed as an instructor at West Point and on engineer duty in Texas, Oregon, and Washington, and in 1855 was one of three American officers sent to observe the campaign in the Crimea. In 1857 he resigned his commission, and engaged in railroad business until the outbreak of the civil war in 1861. In April he was appointed major-general of Ohio volunteers, and in May a major-general in the United States Army. By the middle of July he had driven the enemy out of West Virginia, which entered the Union as a separate state the year after. McClellan was now called to Washington to reorganise the Army of the Potomac, which was made up of either raw recruits or regiments fresh from the defeat at Bull Run; of these he received the command in August, and in November he was made commander-in-chief. But the authorities at Washington were too nervous to rest content with so slow and careful an organiser as McClellan; and when, in April 1862, he landed at Old Point Comfort, for the invasion of Virginia by the peninsula of the James River, he had already

been deprived of the command-in-chief. His peninsular campaign lasted till July, and ended disastrously, partly from want of support, and partly from over-caution. He advanced near to Richmond, but was compelled to retreat, fighting the 'seven days' battles' (June 25 to July 1) as he did so, and finally to evacuate the peninsula. He was now relieved of his command; but after the disastrous second battle of Bull Run (August 29-30), which was followed by a Confederate invasion of Maryland, he reorganised the army at Washington, marched rapidly north, met the forces of General Lee at Antietam (q.v.), and compelled him to re-cross the Potomac. This short campaign was McClellan's most brilliant achievement, but he undoubtedly failed to pursue his advantage as rapidly as he should. He followed the Confederates into Virginia, but with too great deliberation for the taste of the impatient cabinet, and in November he was superseded by General Burnside (q.v.). Here his share in the war ended. In 1864 he resigned his commission, and unsuccessfully opposed Lincoln for the presidency (see p. 640). He was then in Europe till 1868, and in 1875 was elected governor of New Jersey. He died at Orange, New Jersey, 29th October 1885. McClellan was the idol of his soldiers, and deserved their love by his care for them; but his caution in the field was excessive, and he was slow in preparing fresh plans or in meeting unexpected combinations. See his *Report on the Organisation and Campaigns of the Army of the Potomac* (1864); and *McClellan's Own Story*, edited by W. C. Prime (1886).

Macclesfield, an ancient municipal borough and important manufacturing town in the Macclesfield parliamentary division of Cheshire, is situated on the river Bollin, and on the western declivity of a range of low hills, 15 miles SSE. of Manchester and 167 NW. of London. Among its buildings are the fine old church of St Michael, founded by Queen Eleanor in 1278, the town-hall (1823-70), the infirmary (1872), and King Edward's grammar-school (1553), rebuilt in 1866, and reorganised in 1880, with an endowment of £2000 a year, which also supports a modern free school. Macclesfield has a public park of 16 acres (1852), public baths, a free library, a technical school, a school of science and art, &c. The old button trade belongs to the past; and the silk manufacture, established in 1756, is now the staple industry; cotton goods and smallwares are manufactured, and there are dye-works and breweries. In the vicinity coal, slate, and stone are obtained. Macclesfield, which possesses nine charters (the first by Prince Edward, Earl of Chester, in 1261), and which returned two members to parliament from 1832 till 1880, was disfranchised in 1885. Pop. (1851) 29,048; (1881) 37,514; (1891) 36,009. See works by Cory (1817) and Earwaker (1877).

McClure, SIR ROBERT JOHN LI. MESURILL, the discoverer of the North-west Passage, was born at Wexford, 28th January 1807, and entered the navy in 1824, served in Back's Arctic Expedition in 1836, and Ross's Franklin Expedition in 1848. As commander of another Franklin Expedition (1850-54) he passed in a sledge from Barrow Strait, where his ship, the *Investigator*, lay, to Melville Sound, connecting with the Arctic Ocean to the west. McClure was rescued by another expedition, made K.C.B., and after serving in Chinese waters, an admiral. He died 17th October 1873. See POLAR EXPLORATION and works there cited.

McCosh, JAMES, one of the most voluminous defenders of the Scottish philosophy in recent times, was born at Carskeoch, Ayrshire, 1st April 1811. After studying at Glasgow and Edinburgh, he became a minister of the Church of Scotland,

and was settled at Arbroath in 1835. In 1839 he removed to Brechin, and four years later cast in his lot with the Free Church. In 1851 he was appointed professor of Logic and Metaphysics in Queen's College, Belfast, a position which he held till 1868, when he was called to the Presidency of the college of New Jersey, Princeton, U.S.A. After a very successful tenure, Dr M'Cosh resigned this office in 1888 in order to devote the close of his life more exclusively to philosophical production. Dr M'Cosh's first important work was *The Method of the Divine Government, Physical and Moral* (1850; 9th ed. 1867). It was followed in 1860 by *The Intuitions of the Mind inductively investigated*. When Mill published his *Examination of Sir W. Hamilton's Philosophy* in 1865, Dr M'Cosh was one of the numerous critics who broke a lance for Scottish philosophy and examined the examiner. His *Examination of Mr J. S. Mill's Philosophy* (1866) is entitled 'a defence of fundamental truth.' Dr M'Cosh, who died 16th November 1894, defended what he considers the Natural Realism of Reid against both the empirical school and the relativistic views of Kant, Hamilton, and Mansel; and maintained the older intuitional view against the associationists and evolutionists on the one hand and the transcendentalists on the other. In 1875 he published a useful history of *The Scottish Philosophy*. He has also published a series of philosophical tracts for the times, collected as *Realistic Philosophy* (2 vols. 1887), *Psychology* (1886), and *First and Fundamental Truths* (1889). *The Religious Aspect of Evolution* appeared in 1890.

M'Crìe, DR THOMAS, a learned Scottish historian and divine, was born at Duns in November 1772, studied at the university of Edinburgh, and was ordained in 1795 pastor of an Anti-burgher congregation in that city. Here he died, 5th August 1835. M'Crìe's works are in the highest degree valuable to the student of Scottish ecclesiastical history. They exhibit research at once vast and minute, and though they are essentially apologetic, yet their author is never consciously unfair, and does not misstate facts. He shows, however, such admirable skill in finding palliation even for the less defensible acts of the Reformers, and so warm a zeal for Presbyterianism, that the impartial Hallam described his spirit as 'Presbyterian Hildebrandism.' He attacked Sir Walter Scott's account of the Covenanters in *Old Mortality* in three trenchant papers in the *Edinburgh Christian Instructor*, and most unprejudiced readers were compelled to admit that he had the best of the controversy. Readers of *My Schools and Schoolmasters* will remember the admirable description of the militant-looking divine's person and preaching. His best-known works are *The Life of John Knox* (1812), *The Life of Andrew Melville* (1819), and the less satisfactory *History of the Progress and Suppression of the Reformation in Spain* (1829). His works were collected in 4 vols. (1855-56), and a Life was published in 1840 by his son, Thomas M'Crìe, D.D., LL.D. (1798-1875), professor in the Presbyterian college at London, and himself the author of *Sketches of Scottish Church History* (1841), and *Annals of English Presbyterianism* (1872).

M'ulloch, HORATIO, a Scottish landscape-painter, was born in Glasgow in 1805. He exhibited for the first time in 1829; in 1836 he was elected an A.R.S.A., and in 1838 an R.S.A., when he removed to Edinburgh. Here he lived till his death on 24th June 1867. He painted the Highland landscapes with unrivalled truth, breadth, and imagination, among his principal pictures being 'Highland Loch,' 'Loch-an-Eilan,' 'View in Cadzow Forest,' 'Dream of the Forest,' 'Misty Corries,' 'Deer Forest, Isle of Skye,' 'Loch

Achray,' 'Mist rising off the Mountains,' 'Kilchurn Castle, Loch Awe,' and 'Bothwell Castle, on the Clyde.'

MacCulloch, JOHN, geologist, born in Guernsey of a Scottish family on 6th October 1773, studied medicine at Edinburgh, and became assistant-surgeon to an artillery regiment. In 1811 he was employed by government in geological and mineralogical researches in Scotland; in 1820 he became physician to Prince Leopold of Saxe-Coburg, afterwards king of the Belgians; and in the later years of his life he was professor of Chemistry and Geology in the East India Company's military school at Addiscombe. He died at Penzance, Cornwall, 21st August 1835, in consequence of an amputation rendered necessary by a carriage accident. His most important works are a *Description of the Western Islands of Scotland* (1819); *A Geological Classification of Rocks, with Descriptive Synopses* (1821); *A System of Geology, with a Theory of the Earth* (1831); *Malaria* (1827); and *The Remittent and Intermittent Diseases* (2 vols. 1828).

M'ulloch, JOHN RAMSAY, political economist, was born at Whithorn, Wigtownshire, 1st March 1789. At first a clerk in a lawyer's office, he became known in connection with the *Scotsman* newspaper (of which he was editor in 1818-19) and the *Edinburgh Review*. He made his debut in the *Review* in 1818, with an article on Ricardo's *Principles of Political Economy*, and for twenty years contributed almost all the economical articles, with a few on other subjects. He lectured and taught in London on political economy; in 1828 was chosen professor of Political Economy in University College, London; in 1838 was appointed Comptroller of H.M. Stationery Office, a situation which he held till his death, 11th November 1864. His principal publications comprise: *The Principles of Political Economy* (1820); *The Literature of Political Economy* (1845); *On the Succession to Property vacant by Death* (1848); *On the Rate of Wages* (1826-51); *A Dictionary of Commerce* (1832; new ed. 1875-80); *Dictionary of the British Empire* (1837); *Geographical Dictionary; A Treatise on Taxation and the Funding System* (1845); *Dictionary, Geographical, Statistical, &c.* (1841-42); *Partnership, &c.* (1856). He also edited Smith's *Wealth of Nations* and Ricardo's works. M'ulloch was a Foreign Associate of the Institute of France; and Peel conferred on him a pension of £200 a year.

MacCunn, HAMISH, composer, was born in Greenock, 22d March 1868. After study under local teachers, in 1883 he won a scholarship at the Royal College of Music. His progress there was so rapid that in the following year he was able to resign it. In 1888 he was appointed a junior professor of Harmony at the Royal Academy. He is regarded as one of the most promising composers of the day, his works having already won high approbation. Beginning with the overture *Cior Mhor* produced at Glasgow, 22d Jan. 1887, they embrace two other overtures, *Land of the Mountain and the Flood* and *The Dowie Dens of Yarrow*; choral works, including *The Lay of the Last Minstrel*; some songs; and the operas *Jeanie Deans* (1894) and *Diocletian* (1897); libretto by present Duke of Argyll. Possessing fertility in melody and a remarkable mastery of the orchestra, he is a pronounced upholder of nationality in music, and his works are distinctly Scottish in character.

Macdonald, ETIENNE JACQUES JOSEPH ALEXANDRE, was born 17th November 1765 at Sedan, his father, a schoolmaster (born in South Uist, educated at Douai), who followed Prince Charlie to France, being of the stock to which Flora

Macdonald also belonged. He entered the army in 1781 and, embracing the cause of the Revolution, rapidly rose to high rank: he distinguished himself at Jemappes, and by the capture of the Dutch fleet (1795) after crossing the ice. In 1798 he was made governor of the Roman States, and, having routed the army of the king of Naples at Otricoli, he completed the subjugation of that kingdom. In the following year he marched to North Italy, to check the inroad of Suwaroff, who, however, defeated him after a three days' bloody contest on the Trebbia. In 1800 and 1801 he commanded the army of reserve in Switzerland and marched across the Splügen. But in 1805 he lost the favour of Bonaparte by his support of Moreau. Four years later the emperor, hard pressed, summoned Macdonald to command the right wing of the army of Italy. He took Laibach, and distinguished himself at Wagram, and was created marshal and Duke of Taranto. He held a command in Spain in 1810, and in the Russian campaign; and in 1813 he contributed to the successes of Lutzen and Bautzen, but was utterly routed by Blücher at the Kutzbach. After the battle of Leipzig he helped to cover the retreat of the French army. In the subsequent struggles on French ground Macdonald made desperate efforts to face the enemies of Napoleon; but, seeing that further resistance was hopeless, he advised the emperor to abdicate. The Bourbons made him a peer, and gave him the command of a military division; but he refused to serve during the Hundred Days. From 1816 he was Chancellor of the Legion of Honour, and took an active part in the discussions of the Chamber of Peers. He died at Courcelles, Loire, 25th September 1840. See his *Souvenirs* (1892; trans. 1892).

Macdonald, FLORA, 'a name,' said Dr Johnson, 'that will be mentioned in history, and, if courage and fidelity are virtues, mentioned with honour.' Born in 1722 at Milton in South Uist, she lost her father, a tacksman, at two; and her mother four years later was abducted to Skye by Hugh Macdonald of Armadale. Flora stayed behind in Uist with her only surviving brother, Angus, and at thirteen was practically adopted by Lady Clanranald, the wife of the chief of the clan. To this Flora owed her gentle upbringing, her three years' schooling at Edinburgh. She had not long returned to the Hebrides when the rebellion of the '45 broke out; and in June 1746, ten weeks after Culloden, she conducted Prince Charles Edward, disguised as 'Betty Burke, the Irishwoman,' from Ormicule in Benbecula to Monkstall in Skye, and thence by way of Kingsburgh to Portree. That she was in love with the 'young hero' is absolutely false—she was not even a Jacobite; but those three short perilous days endeared her to more than Jacobites, and she was much feted during her twelvemonth's captivity on the troopship in Leith Roads and at London. In 1750 she married the son of Macdonald of Kingsburgh, and at Kingsburgh in 1773 she entertained Dr Johnson, who describes her as 'of middle stature, soft features, gentle manners, and elegant presence.' In 1774 her husband emigrated to North Carolina, and in 1776, on the outbreak of the war of independence, he became a brigadier-general (his five sons, too, were all British officers). He himself was made prisoner; and Flora, returning to Scotland in 1779 with her younger daughter, got her arm broken during the voyage in a fight with a French privateer. After two years at Milton, she was rejoined by her husband, and they settled again at Kingsburgh; but it was at Peindinn, a neighbour's house, that she died on 5th March 1790. Shrouded in a sheet that had wrapped Prince Charles Edward, she was buried at Kilmuir, in a grave

now marked by an Iona cross (1880) of Aberdeen granite, 28½ feet high.

The so-called *Autobiography of Flora Macdonald* (2 vols. 1869) is a silly forgery; but reference may be made to *Flora Macdonald and Prince Charles*, by the Rev. Alexander MacGregor (1882), and to *Flora Macdonald in Uist*, by W. Jolly (1886).

Macdonald, GEORGE, a Scottish poet and novelist, born at Huntly, Aberdeenshire, in 1824, educated at Aberdeen University and the theological college of the Congregationalists at High-bury. He became minister at Arundel in Sussex, and afterwards at Manchester, but was compelled by the state of his health to give up preaching. A short residence in Algiers restored him to comparative vigour, and, returning to London, he took to literature as a profession. His first book, *Within and Without*, a poem, appeared in 1856, and was followed by *Poems* (1857), and *Phantastes, a Faerie Romance* (1858), a poem as irregular as *Kilnycny*, and almost as full of beauty and power. A long series of novels followed, including *David Elyngbrod* (1862); *The Portul* (1864); *Alice Forbes of Howglen* (1865); *Annals of a Quiet Neighbourhood* (1866); *Guild Court* (1867); *The Seaboard Parish* (1868); *Robert Falconer* (1868); *Wilfrid Cumbermole* (1871); *Malcolm* (1874); *St George and St Michael* (1875); *Thomas Wingfold, Curate* (1876); *The Marquis of Lossie* (1877); *Sir Gibbie* (1879); *What's Mine's Mine* (1886); *Lilith* (1895); and *Salted with Fire* (1897). Almost all these novels contain passages of singular beauty, and are lightened up by fine fancy and descriptive power, but they are badly constructed and defective in harmony as works of art. They reveal the deep spiritual instincts of their author in his reaction against Calvinism, as well as the nebulousness of his mental atmosphere and his inability for sustained thought. The dialect is that of Aberdeen and the north-eastern counties, and sounds feeble to the ear after the classic vigour of the language of Burns and Scott. He has also published books for the young: *Dealings with the Fairies* (1867), *Ronald Bannerman's Boyhood* (1869), *At the Back of the North Wind* (1870), and *The Princess and the Goblin* (1871); besides religious works: *Unspoken Sermons* (3 series, 1866-89), and *The Miracles of Our Lord* (1870). Macdonald is well known as a lecturer, and in 1872-73 he made a lecturing tour in the United States. In 1877 he received a Civil List pension of £100.

Macdonald, SIR JOHN ALEXANDER, Canadian statesman, was born in Glasgow, 11th January 1815, and with his parents emigrated five years later to Canada. He was educated at Kingston, called to the bar in 1836, and appointed a Q.C. in 1846. He represented Kingston in the Canada Assembly from 1844 till the union of the provinces in 1867, and in the Dominion parliament till 1878, when he was defeated; but he afterwards sat for Victoria, British Columbia, and for Carleton and Lennox, and was again returned by his old constituency in 1887. Before the union he had been Receiver-general in 1847, Commissioner of Crown Lands in 1847-48, Attorney general for Upper Canada in 1854-58, succeeding Sir Allan Macnab as leader of the Conservatives and premier in 1856, and again Attorney general in 1858-62 and 1864-67. On 1st July 1867, when the new constitution came into force, he was called upon to form the first government for the new Dominion, and was minister of Justice and Attorney general of Canada until he and his cabinet resigned in 1873. He was again returned to power in 1878, and was successful in the elections of 1882 and 1887. In 1878 his success was owing to the adoption of a policy of protection for native industries, which discriminates against the productions of all other

countries, not even excepting Great Britain. Sir John was mainly instrumental in bringing about the confederation of the British North American provinces, and in securing the construction of the Intercolonial and Pacific railways; and he was a pioneer of imperial unity. In 1871 he was appointed one of the British Commissioners for the settlement of the Alabama claims. He was made a privy-councillor in 1872, K.C.B. in 1867, and G.C.B. in 1881, and received honours from Oxford and the Canadian universities. He died 6th June 1891. His widow was made a peeress of the United Kingdom, and a bust of Sir John was erected in Westminster Abbey in 1892. See Life by Pope (1894).

Macduff. See BAXFF.

Mace, a thick, heavy club or staff, about 5 feet long, surmounted by a metal head, frequently spiked, which was used by knights and warlike churchmen in the middle ages. The ornamental maces of parliament, the universities, and city corporations, borne as an ensign of authority, may be traced to the 12th and 13th centuries, when princes armed their guards with spikeless maces as the handiest against the sudden attacks of the Assassins (q.v.). The need passed away, but the maces remained as symbols of rank. The House of Commons has possessed three maces. The first disappeared after the execution of Charles I. The second was the 'hauble' that Cromwell had removed; it has been claimed that a mace preserved in the museum at Kingston, Jamaica, is the same. The sergeant-at-arms at the close of the session hands over the mace to an official of the crown, getting a receipt for it; it is kept under lock and key till the House meets again. In the congress of the United States the sergeant-at-arms has a silver mace. The Lord Mayor's mace, of silver gilt, and weighing nearly a quarter of a hundred weight, dates from 1735.

Mace, the Aril (q.v.) or inner covering of the Nutmeg (q.v.). It is a lacerated membrane, blood-red when fresh, varying in length according to the variety. There are two varieties of nutmeg cultivated, one named 'Royal,' the other 'Green.' The former bears the longer and finer quality of mace. The mace is removed from the nutmeg and dried in the sun a few days, when it quickly loses its fine red colour and becomes light brown. It is then sprinkled with sea-water to preserve it and render it flexible, and is pressed flat, in which condition it is exported, chiefly from Penang and Singapore. Mace is the most aromatic part of the fruit, and yields both fixed and essential oils. The former, obtained by expression, is highly fragrant, of buttery consistence, and brown colour. It is powerfully stimulant, and in India is employed as a liniment and embrocation in rheumatism. The essential oil is extracted by distillation. It possesses the fragrance of mace, and is yellow in colour. Mace is a native of the Moluccas and neighbouring islands, but is cultivated in Java, Penang, Sumatra, Mauritius, and other parts of the East, and in Cayenne, Martinique, and some of the West India Islands. The aril of other species of Myristica (Nutmeg) of inferior quality occasionally appears in commerce.

Macedonia, anciently the name of a country lying N.W. of the Egean Sea. Originally of small extent, it stretched at the period of its greatest area from the Hæmus (mod. Balkan) range on the N. to Thessaly and the Egean on the S., and from Epirus and Illyria on the W. to Thrace on the E. The country is on the whole mountainous, especially in the south and west, but there are several large plains of great fertility. The principal rivers were the Strymon, Axius, and Haliacmon. Compare TURKEY. Macedonia was famous

for its gold and silver mines, and its oil and wine. It contained a number of flourishing cities, of which the names are well known in ancient history, particularly Egea (Edessa) and Pella, the capitals, Pydna, Thessalonica, Potidea, Olynthos, Philippi, and Amphipolis. Perdiccas I. (c. 700 B.C.) is reputed to have been the first king and founder of the Macedonian monarchy. In 490 B.C. and again ten years later Macedonia was compelled to take part with the Persians in their invasions of Greece. Under the wise and vigorous reign of Archelaus (413-399 B.C.), an admirer of Greek art and civilisation, Macedonia greatly increased in prosperity and power. But a period of civil wars and anarchy then ensued, and was only terminated by the accession of Philip II. (359 B.C.), who, having seated himself firmly on the throne, developed the resources of his kingdom, and laid the foundation of its future greatness (see GREECE). His son, Alexander III., surnamed the Great, brought half the then known world under his sway; but after his death the Macedonian empire was broken up, and, after twenty-two years of incessant warfare, was formed into four kingdoms under his principal generals (see PHILIP and ALEXANDER). Macedonia, with Greece, fell to Antipater's son Cassander. But in the wars against the Gauls, the civil strifes of the descendants of Alexander's generals, and in the ambitious designs of Pyrrhus, king of Epirus, Macedonia almost perished as a kingdom. It was, however, once more established securely by Antigonus Gonatas (277-239), the grandson of Alexander's general Antigonus, who had obtained part of Asia Minor. The kingdom preserved the limits set it by Antigonus down to its conquest by the Romans in 168 B.C. Twenty-five years later Macedonia was made a Roman province, in which Thessaly and part of Illyria were included. On the partition of the Roman world, it was incorporated in the eastern empire. In the end of the 6th century it was settled by Slavonic races, and subsequently formed part of the kingdoms of the Bulgarians (10th century), Salonica (ruled by Boniface, Marquis of Montferrat), Thessalonica (1224), the Servians (14th century), and finally the Turks, who still hold it. The population of the coast districts are Greeks, whilst in the interior Christian Bulgarians greatly preponderate.

Maccio, a part of Brazil, the capital of Alagoas state, lies on a peninsula that shuts in the Lagoa do Norte from the sea. Cotton and machinery are manufactured, and there is an active trade in maize, sugar, cotton, &c. Two railways run from here into the interior. Pop. 12,000.

Macerata, a walled town of Central Italy, picturesquely perched upon an eminence (1207 feet), 41 miles by rail S. of Ancona. It has a cathedral, a beautiful town-hall of the 13th century; university, and manufactures of glass and pottery. Pop. 10,063.

Macfarren, SIR GEORGE ALEXANDER, one of the most prominent composers and writers on musical theory during the 19th century in England, was born in London, March 2, 1813, and educated at the Royal Academy of Music, at which institution he became a professor in 1834. In 1875 he was appointed Principal of the Academy, and also professor of Music at Cambridge University. Later in life he became blind, and died 31st October 1887. He was knighted in 1883. As an operatic composer Macfarren is the most characteristic representative of the national English school—his aim being to revive the old English music in modern opera. His earliest dramatic work, *The Devil's Opera*, was produced in 1838; *Don Quixote* followed

in 1846, *King Charles II.* in 1849, *Robin Hood* in 1860, *Jessy Lea* in 1863, and *She Stoops to Conquer, The Soldier's Legacy, and Helvellyn* in 1864. His best cantatas were *Lenore* (1852), *May-day* (1853), *Christmas* (1860), and *The Lady of the Lake* (1877). He did not produce his first oratorio, *John the Baptist*, until 1873: it had for successors, *The Resurrection* (1876), *Joseph* (1877), and *David* (1883). Macfarren's works comprise numerous other small dramatic pieces, as well as chamber music, vocal and instrumental, and several symphonies and overtures. He stands higher, however, as a writer on the theory of music than as a composer. He was an enthusiastic advocate of the views of Alfred Day (1810-49) as laid down in that writer's *Treatise on Harmony* (1845), and for many years stood almost alone in his advocacy of it. As a decided conservative in music, Macfarren manifested little sympathy for such modern schools as Wagner's. He wrote *Rudiments of Harmony* (1860; 13th ed. 1885), *Lectures on Harmony* (1867; 3d ed. 1882), *Counterpoint* (6th ed. 1886), *A Musical History* (1885), and *Addresses and Lectures* (1888); besides editing *Old English Ditties* (1857-80), *Moor's Irish Melodies* (1859), *Scottish Ditties* (1861-80), and the second edition of Day's *Treatise* (1886). See the *Life and Works of Sir G. A. Macfarren* (1891).

M'Gill, James, philanthropist, was born in Glasgow, 6th October 1744, and died in Montreal, Canada, 19th December 1813. He emigrated to Canada before the American revolution, engaged for some time in the North-west fur trade, and, subsequently settling in Montreal, became a successful merchant there. He was for many years a member of the Lower Canada Assembly, and subsequently a member of the legislative and executive councils. He was noted for philanthropy. He bequeathed to the college in Montreal that bears his name property valued at £30,000 and £10,000 in money; but, in consequence of the increased value of land, these figures convey a very inadequate idea of the present value of his gift to McGill College.

Macgillyendy Reeks, a group of rugged mountains in Ireland, in County Kerry, rise from the western shores of the Lakes of Killarney, and cover an area of 28 sq. m. Carran-Tuad, the loftiest peak, not only of the Reeks but in all Ireland, is 3414 feet in height. Caher, the next in altitude, reaches 3200 feet, and there are several others which exceed 2500 feet.

MacGregor, John, canoeist and philanthropist, eldest son of General Sir Duncan MacGregor, was born at Gravesend, January 24, 1825, and a few weeks later was the first to be handed out of the burning *Kent*, East Indianman. He was educated at various private schools, at Dublin, and at Trinity College, Cambridge, where he graduated as a wrangler, and took his B.A. in 1847. In the same year he entered the Inner Temple, and was called to the bar in 1851. He did some writing and sketching for *Punch* in 1845. His desire to travel led him to make a tour of Europe, Egypt, and Palestine (1849-50); and a subsequent visit to the United States and Canada bore fruit in *Our Brothers and Cousins* (1859). The rise of British canoeing has been largely due to his example and influence since 1850. He published an account of a canoe journey in 1865, under the title of *A Thousand Miles in the Rob Roy Canoe* (1866). Other narratives of canoe voyages on the Baltic, Zuider Zee, and Jordan followed. He was captain of the Canoe Club (1866), and contributed papers on Marine Propulsion to the British Association. He was a member of the London School Board for Greenwich in 1870, and again in 1873; when chairman of the Industrial School Commission, he sug-

gested the founding of the London Shoebblack Brigade; and he gave the profits of his books and lectures—£10,000 to philanthropic schemes. He died 16th July 1892. See *Life* by Hodder (1894).

MacGregor, Robert. See *Rob Roy*.

Machair'odus, a gigantic sabre-toothed tiger of the Pleistocene period, with canine teeth 6 or 8 inches long, and jagged at their edges like a fine saw. Its remains were found in Kent's Cavern (q.v.).

Machiavelli, Niccolò di Bernardo del, born of an ancient burgher family at Florence, in 1469, and a pupil of the celebrated scholar, Marcello Virgilio, was employed in public affairs from a very early age, and may be regarded as the literary representative of the political life of the important period to which he belongs. The years of his early manhood were passed amid the political troubles occasioned by the French invasion under Charles VIII. (1493), when the Medici fled from Florence, and the republic was proclaimed, and a new constitution formed under the influence of the great reformer, Savonarola. Machiavelli's first appearance in public life was in the year of his famous contemporary's fall from power, and execution. He was elected in June 1498 to a subordinate secretaryship in the department of 'Il vece di Balìa'—i.e. the Ten chosen to direct the military and diplomatic affairs of the republican government. He was promoted in July of the same year to the chief-secretaryship under this same commission. This position, which, though honourable, was subordinate, he occupied until the fall of the republic in 1512. His immediate superior in office was Marcello Virgilio Adriani, a celebrated humanist, whose companionship is supposed to have stimulated in Machiavelli the enthusiasm for the study of the classics. It seems proved, however, that Machiavelli did not know Greek, and cannot be classed among the erudite of that cultured age. Machiavelli's duties were almost entirely diplomatic: he was employed in a great variety of missions, the instructions and correspondence connected with which may almost be said to contain the secret political history of Italy during his time. The culminating point of his reputation as a diplomatist was his mission to the great master of treachery and dissimulation, Cesar Borgia, Duke of Valentinois, commonly called 'Il Valentino,' in 1502, of which an account is preserved in fifty-two letters written during the course of the negotiation, unsurpassed in dramatic interest by any series of state papers. In the complicated external relations which Florence had now assumed, Machiavelli is found in communication with all the great foreign powers, as he had hitherto been with the Italian principalities. Between 1500-11 he formed part of important missions, once to the German emperor Maximilian, and four times to France. His despatches during these journeys, and his treatises on the 'Affairs of France and Germany,' are full of a far-reaching insight into the causes and effects of the various characteristics he had seen and studied. The most important part which Machiavelli took in public affairs was his spirited attempt to raise a trained body of citizens able, without the aid of treacherous mercenaries, to defend their liberty against foreign invasion.

The sincere patriotism which ennobles his writings and his life filled him with forebodings for the fate of his country, and especially of his beloved native town, and inspired him to teach with fervour the only mode of reviving her ancient dignity and independence. On the restoration of the Medici in 1512, Machiavelli was involved in the downfall of his patron, the Gonfaloniere Soderini. He was arrested on a charge of conspiracy in 1513.

On being put to the torture, he disclaimed all knowledge of the alleged conspiracy; but, although pardoned, in virtue of the amnesty ordered by Leo X., he was obliged for several years to withdraw from public life, during which period he devoted himself to literature. It was not till the death of the young Lorenzo de' Medici, in 1519, that Machiavelli began to recover favour. He was commissioned in that year by Leo X. to draw up his report on a reform of the state of Florence; and in 1521 and the following years he was officially employed in various diplomatic services and as historiographer. After the disastrous defeat of the French at Pavia (1525), Italy lay helpless before the advancing forces of the Emperor Charles V., whose ferocious soldiery, though nominally allies, sacked the rich and defenceless Italian towns in their power. Machiavelli used his failing energies, undermined by chronic disease, to rouse his fellow citizens in their own defence, and in negotiations to avert from Florence the invading army on its way to Rome. In May 1527, on receiving the news of the sack of Rome and imprisonment of Pope Clement VII. (Ginlio de' Medici), the Florentines again drove out the Medici rulers and proclaimed the republic. But Machiavelli found that he was to be allowed no part in the popular movement for liberty and for defence against the foreigner; his patriotism was doubted, and he was suspected of favouring the Medici. This bitter disappointment, added to his already feeble health, brought on an illness, of which he died on the 20th June of the same year. His death was accompanied by the usual ministrations of the church, for, though he had written much against clerical corruption and tyranny, he had never impugned, nor indeed even disowned, religious doctrine. He was interred in his family's burying-place in Santa Croce, but all exact record of the spot is lost, the family having become extinct as early as 1597.

Through misrepresentation and misunderstanding of his writings, his name became after his death hated, and his teachings were spoken of as almost diabolical, his earliest and most violent assailants being the clergy, and especially the Jesuits. Although his writings were several times partially published in a more or less garbled form, the first great edition was not issued until 1782; it was dedicated to Earl Cowper, who had had a leading part in encouraging the publication, as also in promoting a public subscription for a monument to Machiavelli in Santa Croce. From that period until our own day his fame has steadily increased, and his pre-eminent position as the founder of political science is now assured.

Machiavelli's writings fill 6 vols. 4to (Florence, 1782), or 10 vols. 8vo. Besides his letters and state-papers, his historical writings also comprise *Florentine Histories*, extending from 1215 to 1492, with a fragmentary continuation to 1499; *Discourses on the First Decade of Titus Livius*; a *Life of Casteruccio Casteruciani* (unfinished); a *History of the Affairs of Lucca*. His literary works comprise an imitation of the *Golden Ass* of Apuleius, an essay on the Italian language, and several minor compositions. He also wrote *Seven Books on the Art of War*, which has been much admired by the learned in military science. But the great source of his reputation, for good or for evil, is the celebrated book *De Principatibus*, or, as it has since been called, *Il Principe*. The main question discussed in this world-famed book is: How principalities may be governed and maintained. In resolving this question, various cases are supposed, for each of which appropriate rules, principles, and suggestions are laid down, and all are illustrated both by contemporary examples and by a wealth of historical learning which it is difficult

to overrate. The 7th chapter, in which he details with evident admiration the system of Caesar Borgia, and the 18th, in which he discusses 'the duty of princes as to the obligation of keeping faith,' are perhaps those which have most contributed to draw upon the author the odious reputation of which his very name has become the symbol; but, in truth, these chapters are only more precise and more formal than the rest, from their heaping together statements which are elsewhere insinuated or supposed. The broad scheme of the book is everywhere the same—viz. that for the establishment and maintenance of authority all means may be resorted to, and that the worst and most treacherous acts of the ruler, however unlawful in themselves, are justified by the wickedness and treachery of the governed. Such being the moral of the book, a question has arisen as to the intention of the writer, and a favourite theory for a time prevailed, that *The Prince* was but a satire upon absolutism, and was designed to serve the cause of liberty, of which Machiavelli was an ardent friend, by making arbitrary power odious and contemptible. This theory, however, besides being utterly irreconcilable with the tone of the work, is completely disproved by a letter of Machiavelli to his friend Vettori (1513), which was discovered only in 1810, and which shows that *The Prince* was written by Machiavelli in all seriousness, in order to recommend himself to the Medici (for whose private perusal it was designed, and not for publication) as a master in the art of government. In his ardour for the liberation of Italy from the rule of foreigners, Machiavelli had become convinced that strong native governments, even though absolute, must be endured; and, having accepted that of the Medici for Florence, he was content to use all means for its security and consolidation. *The Prince* was published, after Machiavelli's death, at Rome, in 1532; and, if any doubt should be entertained as to the seriousness of the author, the book need only be compared with the commentary which is furnished by every page of his *Legazioni*, or the reports of his diplomatic missions, which are also contained in his collected works. Of the many criticisms and rejoinders to which *The Prince* has given occasion, the most remarkable is that of Frederick the Great, *Anti-Machiavelli, ou Examen du Prince de Machiavelli* (1740); and *The Prince* was condemned by Pope Clement VIII.

The comedies of Machiavelli form an epoch in the history of the Italian theatre, as he and his great contemporary, Ariosto, were the first to represent actual life and dialogue in their plays. Machiavelli's famous comedy, *La Mandragola*, full of biting humour and shameless indecency, is a masterpiece of dramatic art.

Among the many noted historians who have discussed the work and morality of Machiavelli, we may note Macaulay's brilliant essay, and in the more modern style of historical criticism Leopold Ranke's study in *Zur Kritik neuerer Geschichtschreiber*. The most complete and remarkable work on Machiavelli is that by P. Villari, *Niccolò Machiavelli e i suoi tempi* (1877-82; Eng. trans. 1890). Tommasini's *Vita e Scritti di Machiavelli* (1883) is full of careful research. Mr John Morley's Romanes Lecture on *Machiavelli* was published in 1897.

Machine Gun may be defined as a weapon mechanically loaded with fixed ammunition from a hopper or frame, so as to fire a succession of projectiles from a rest or carriage, in contradistinction to hand weapons, such as Repeating (or magazine) Rifles (q.v.) and Revolvers (q.v.).

Machine guns may be divided into two classes—the mitrailleuse, which discharges a stream of bullets not much exceeding 1 inch in diameter, and the revolving cannon or quick-firing gun, which throws an explosive shell of several pounds

weight. The first class includes rifle-calibre guns for use against troops, and naval guns firing steel shot capable of piercing the sides of a torpedo boat. The second is an improvement on ordinary Cannon (q.v.), though perhaps sometimes considered less suited to all the contingencies of a campaign, in consequence of the comparatively delicate nature of the mechanism employed.

A breech-loading Requa battery (an improved Ribaudequin or organ gun), consisting of thirty-one rifle-barrels arranged in three parallel rows, loaded simultaneously by means of a set of chambers, and fired at once by a single cap, has been in the Rotunda Museum at Woolwich since before 1830. A Requa battery was used at the siege of Charleston in 1863, and seems to contain the germ of such inventions as the Gardner and Nordenfelt machine guns, while those like the Gatling and the Hotchkiss revolving cannon seem traceable to the early patterns of revolver-pistol. The first of such weapons to be used in field operations was the Gatling, which was tested in the American civil war, and exhibited in the Paris Exhibition of 1867. This weapon (fig. 1) usually has ten barrels and ten locks, revolved round a fixed axis by means of a handle or crank. In addition to revolving with the barrels, each lock is at the same time gradually pushed forward, so as to carry the cartridge into the barrel, close the breach, and fire the charge as soon as the barrel comes under the sights. It then commences to move backwards, drawing with it the empty cartridge-case, so that, when one revolution of the barrels is complete, the open breech is brought under the drum from which a second cartridge falls into it. Thus, when the ten-barrelled gun is in action, there are always five cartridges going through the loading process and five others being gradually extracted; and this goes on as long as the gun is fed with cartridges, which may be done either by hand, or, as is more usual, by means of a drum fixed above the barrels, as shown in fig. 1. This type of machine gun cannot fire a volley, but the rapidity of its fire is limited only by the movement of the handle,

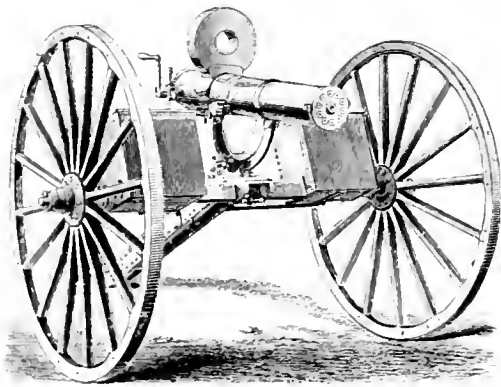

Fig. 1.

Medium size Gatling, mounted on Field Carriage.

It can also be worked with a slight swaying action, when firing rapidly, so as to spread the bullets over a certain amount of lateral space, like water from a fire-hose, and give much the same effect as a volley. The weapons first used fired one hundred bullets each minute, but improved mechanism enables the newer types to fire ten times that number, and to give good results at ranges of 3000 yards. The barrels are of various calibres up to 12 inches; and larger sizes could be made. A few Gatling guns were used in the Franco-German war

of 1870, the Russo-Turkish war of 1877-78, the Chilo-Pernuvian war of 1877, and the British campaigns in Ashantee, Zululand, Egypt, &c.

The Montigny mitrailleuse, adopted by the French army, and used by them in large numbers during the campaign of 1870, consists of thirty-seven rifle-barrels permanently enclosed in an iron cylinder. These are all loaded simultaneously at the breach by means of a metal frame, in which the cartridges are carried, and can be discharged independently or all at once by the action of a crank-handle. Reloading takes five seconds, and ten discharges can be fired per minute. The bullets have no lateral spread, and the effective range is not much over 1000 yards. Numbers of these weapons were secretly manufactured in France previous to 1870, and, on the outbreak of war in that year, were issued to the artillery in place of their field guns, without any instruction having been given to the men in working them. Formed into batteries of ten pieces, they were expected to beat off both artillery and infantry; but the concentrated shell fire of the

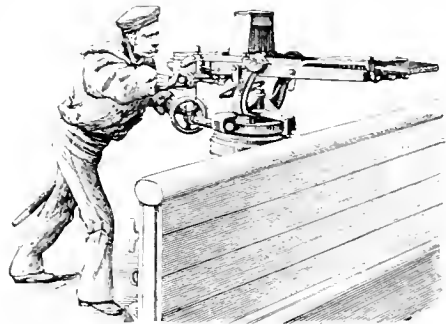

Fig. 2.

Nordenfelt-Palmerantz Gun, inside Bulwark Mounting.

former destroyed them at long ranges, and the rapid movements of the latter often enabled them to capture the mitrailleuses without serious loss. The failure of this weapon brought all machine guns into dis-favour; but when protected from artillery fire in savage warfare, their great value for certain purposes, such as flanking the ditches of fortresses, defending defiles, bridges, &c., and naval operations, has since been fully recognised, and very many improved types have appeared.

The Nordenfelt-Palmerantz system (fig. 2) is particularly useful in the tops of ships. The 4 inch calibre gun, firing steel bullets, is capable of piercing the sides and boilers of torpedo boats at 300 yards. It consists usually of four or more horizontally arranged

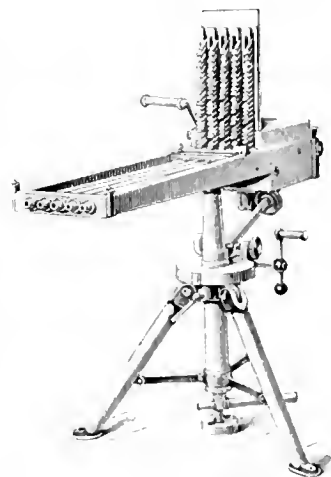

Fig. 3. Five-barrelled Gardner Gun on Tripod Stand.

barrels, and the firing handle on being moved forwards and backwards discharges them all, if moved rapidly, in a succession of volleys, if slowly, in a succession of single shots. The number of aimed shots per minute fired at sea varies from one hundred with the 1-inch to ten with the 3-inch gun.

Fig. 3 shows another form of rifle-calibre machine gun designed by Captain Gardner, late U.S.A., for use with a field army. The operations of loading, firing, and withdrawing the empty cartridge-cases are performed automatically by the breech mechanism, worked by a crank-handle. The cartridges are fed in from an upright frame or carrier.

The Maxim automatic machine gun has a single barrel surrounded by an outer case, the space between being filled with water to prevent heating. The breech end of the gun recoils after discharge (the first cartridge being fed in and fired by hand), causing the arm B (fig. 4) to strike the fixed point C, thus imparting to the crank-shaft E a rapidly accelerated rotation, and making the crank-handle F strike the buffer-spring D, which brings it to a state of rest. The rotation of the crank-shaft E also rotates the fusee (shown dotted round E) attached to the chain, and thereby winds it up, so that, when the crank-handle F rests on the buffer D, the spiral spring (dotted) is not only extended 1 inch (due to the recoil), but further elongated by the winding up of the chain on the fusee. After

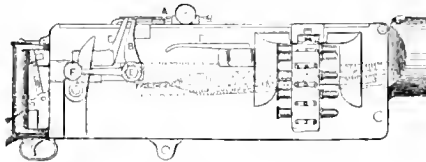

Fig. 4.—Breech Mechanism of Maxim Gun.

the crank-handle F has been brought to rest against the buffer D, the action of the spring is first to pull back the recoiling portion into the firing position, and then to unwind the chain from the fusee, thus rotating the crank-shaft back into its original position. The cartridges are carried on a broad linen belt, to which fresh lengths can be attached, and which is carried round by the mechanism. The accelerated motion of the crank draws back the lock sufficiently to allow the old cartridge to drop out, while the spiral spring causes the lock to come forward quicker than the recoiling portion of the barrel, so that at the same instant as the barrel resumes the firing position the lock closes the breech with a new cartridge and fires it, the recoil setting up the same action again. The gun may be arranged for firing single shots by hand on pressing a button, or to continue firing shots at any required interval of time. As many as 620 rounds per minute have been fired from this gun, and accurate shooting obtained up to 3000 yards. Fig. 5 shows a rifle-calibre Maxim gun, which, with its tripod, only weighs 70 lb. A 3-pounder gun has also been designed on the same principle. All the mechanism is carefully covered in to protect it from grit and dirt, but it can easily be taken to pieces and cleaned.

The Hotchkiss revolving cannon is similar to the Gatling gun, inasmuch as it consists of five barrels revolving round a central axis, but there is only one lock for all five, instead of one for each barrel, and the rotatory motion of the barrels is intermittent instead of continuous. Each turn of the crank-handle loads one barrel and fires another, while an empty cartridge case is being extracted from a third. The mechanism is in few parts, which are large, strong, and serviceable, with only one spring, and that a large flat one. The breech piece is solid.

The calibres of the revolving cannon vary from 1.5 inch to 2 inches, but the same inventor has made a 6-pounder quick-firing single-barrelled field-gun.

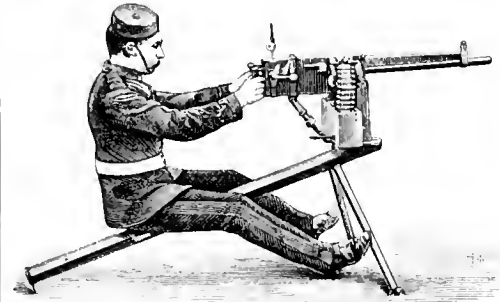

Fig. 5.—Rifle-calibre Maxim Gun.

The projectile is either a steel shot for naval purposes or an explosive shell. As many as eighty rounds per minute have been fired from the revolving cannon, the cartridges being fed in from a hopper frame, and good results obtained at a range of 5460 yards.

By an order of 1888, a detachment with two machine guns was made part of the war establishment of every brigade of infantry or cavalry in the British army. Each infantry detachment consists of an officer, two non-commissioned officers, and nine men, and is accompanied by a forage-cart and ammunition-cart carrying 6640 rounds for the guns, 1500 more being on each gun-carriage. Two men are sufficient to work each gun, the remainder are drivers and a servant. In the cavalry detachment there are fifteen men, of whom two are servants, seven drivers, and six for working the guns and to act as horse-holders. The ammunition-wagon carries 13,340 rounds of rifle-calibre cartridges.

The mitrailleuse form of machine gun thus takes a definite place in the armament of European troops, not as a substitute for field artillery, against which, if unprotected by cover, it can never stand, but as an auxiliary to infantry and to cavalry acting independently, in positions where rifle-fire is most efficacious. It will also be useful for long range rifle-fire, and perhaps in lieu of an infantry escort to guns when moving rapidly to the front, besides those purposes which have already been alluded to. The shell-firing machine gun and the quick-firing gun, on the other hand, will perhaps supersede the ordinary artillery pieces of similar calibre. The one-pounder-shell machine gun (called 'Pom-pom' by the soldiers, from its sound) proved of effectual service in the Transvaal war, 1899-1900.

Macintosh, CHARLES. See INDIA-RUBBER.

McIntyre, DUNCAN BAX. See GAFFLE, V. 52.

Mack, KARL, FRIEDRICH VON, Austrian general, was born at Neun-lingen, in Franconia, on 24th August 1752, entered the military service of Austria in 1770, and, after fighting in the Turkish war and against the French republican armies, was in 1797 created field-marshal. Having, after the peace of Campo Formio, been appointed by the king of Naples to the command of his troops, he took the field against the French, and occupied Rome; but he was unable to retain his hold of the city. A riot in the city of Naples, caused by his having concluded an armistice with the French, compelled him to seek safety in the enemy's camp. He was thereupon carried prisoner to Paris, but escaped in 1800. Five years later the emperor put him at the head of 80,000 men, and sent him to check the

French advance along the line of the Ille. But the enemy outmanœuvred him, and shut him up in Ulna, and on 17th October Mack capitulated with his army. He was tried by court-martial and condemned to death, but the sentence was commuted by the emperor to expulsion from the army and twenty years' imprisonment. In 1808 Mack was liberated, and in 1819 fully pardoned. He died 22d October 1822. His defence was published in Rammer's *Historisches Taschenbuch* (1873).

Mackay, CHARLES, LL.D., poet and journalist, the son of an officer in the Royal Artillery, was born in Perth in 1814. He was sent to school in London and Brussels, and showed an early fondness for verse-writing. In 1830 he became secretary to Cockerill (q.v.) at Seraing. The publication of a small volume of poems in 1834 led to his becoming assistant-editor of the *Morning Chronicle* (1835-44). From 1844-47 he was editor of the *Glasgow Argus*; he acted on the literary staff of the *Illustrated London News* (1848-59), and filled the post of New York correspondent of the *Times* during the civil war (1862-65). The *London Review*, a weekly journal which he established in 1860, was not a success. Down to the time of his death, December 24, 1889, he issued many volumes of poetry and prose, and was a contributor to *Blackwood's Magazine*, the *Nineteenth Century*, and other periodicals. Two of Mackay's songs, 'There's a Good Time Coming' and 'Cheer, Boys, Cheer,' had an extraordinary vogue, 400,000 of the first having been sold, without putting anything into his pocket. He published eleven volumes of poetry; *Gossamer and Snowdrift* (1890) was edited by his son Eric (1851-98); author of *Love-letters of a Violinist*, *Arrows of Song*, *Nero and Actea*, &c. His prose works included *Memoirs of Extraordinary Popular Delusions* (1841), a work on *Gaelic Etymology* (1878), and two works of literary autobiography, *Forty Years' Recollections* (2 vols. 1877) and *Through the Long Day* (2 vols. 1887).

M'Keesport, a borough of Pennsylvania, on the Monongahela River, at the mouth of the Youghiogheny, and on several railways, 15 miles S.E. of Pittsburg. It has flour, saw, and rolling mills, large manufactories of tubing, glass-works, a distillery, &c. Natural gas is used to some extent for fuel. Pop. 8212.

Mackenzie, ALEXANDER, Canadian statesman, was born in Logiehall, Perthshire, 28th January 1822, removed to Canada in 1842, and worked for some time as a mason, subsequently becoming a builder and contractor. In 1852 he became editor of a Reform newspaper. He represented Lambton in parliament from 1861 to 1867, and in the Dominion parliament till 1882; he was then elected for East York, and was re-elected in 1887. From 1867 he led the Reform opposition in parliament, and in 1873-80 was leader of the Liberal party in Canada. In 1873 he succeeded Macdonald, becoming the first Liberal premier, and remained at the head of the government till 1878. He thrice declined a knighthood, wrote the Life of his friend and ally, the Hon. George Brown (1882), and died 17th April 1892.

Mackenzie, SIR ALEXANDER CAMPBELL, composer, knighted in 1895, was born in Edinburgh in 1847. He studied music in Germany and at the Royal Academy, London. From 1865 to 1879 he was engaged in Edinburgh as teacher, violinist, conductor, and composer. Afterwards he resided in Italy, devoting his energy mainly to composition. In 1886 he had the degree of Mus. Doc. from St Andrews University; in February 1887 was appointed Principal of the Royal Academy of Music in London. His works embrace almost every form of music. His celebrity dates from the production

of his opera *Columba* in April 1883 at Drury Lane by the Carl Rosa Company. His subsequent opera, *The Troubadour*, had not the same success. His oratorio, *The Rose of Sharon*, produced at Norwich in 1884, is regarded as hitherto his best work. Another similar one, *The Lord of Life*, was composed for production in 1891 at Birmingham. Besides these, he has written several important cantatas; two Scotch rhapsodies, and other orchestral works, a concerto and a *piroch* for violin; chamber music, songs, pianoforte and organ pieces, &c. His compositions are distinguished by a manly solidity of workmanship, the result of a thorough mastery of all branches of his art, combined in many instances with a happy poetic inspiration. He is also eminent as a conductor.

Mackenzie, SIR GEORGE, a Scottish lawyer and statesman, nephew to the Earl of Seaforth, was born at Dundee in 1636. He studied at St Andrews, Aberdeen, and Bourges in France ('the Athens of Scottish lawyers'); in 1656 was called to the bar at Edinburgh; and in 1661 boldly defended the Marquis of Argyll on his trial for high-treason. About the same time he was made a justice-depute, and as such had to repair once a week at least to Musselburgh and Dalkeith, and to try and judge such persons as are there delated of witchcraft. He was soon after knighted, entered parliament as member for Ross-shire in 1669, and in 1677 was named king's advocate. Up to this point his career had been marked by a decidedly patriotic spirit, and he was even one of the most popular men in the country. In the midst of his professional labours he diligently cultivated literature, and was one of the first Scotchmen to write English with purity. 'That noble wit of Scotland,' Dryden terms him. Unhappily in the popular mind he is better known as criminal prosecutor in the days of the persecution, in which capacity he earned the title of 'Bloody Mackenzie'; nor can it be disproved, in spite of his liberal antecedents, that he became a willing instrument of despotism. In 1682 he founded the Advocates' Library (q.v.); at the Revolution, six years afterwards, he retired to Oxford. He died in London, 8th May 1691, and was buried at Edinburgh in Greyfriars-Churchyard.

His works, published between 1663 and 1686, and collected by Ruddiman (2 vols. folio, 1716-22), include *Religio Stoici*, *Moral Essay upon Solitude*, *Moral Gallantry*, *Vindication of the Government of Charles II.*, three treatises on the law of Scotland, and *Jus Regium*. See his *Memoirs of the Affairs of Scotland* (ed. 1821); and Taylor Innes, *Studies in Scottish History* (1892).

Mackenzie, HENRY, the 'Man of Feeling,' was born in Edinburgh, 26th August 1745. A physician's son, he passed from the High School to the university, in 1765 went up to London to pursue his law studies, and, returning to Scotland, became crown attorney in the Court of Exchequer, and in 1804 comptroller of taxes. For upwards of half a century he was one of the most illustrious names connected with polite literature in Edinburgh, where he died at the great age of eighty-five, on 14th January 1831. His *Man of Feeling* was published anonymously in 1771; *The Man of the World* followed in 1773, and *Julia de Rombou* in 1777. All three have something of Richardson, and more of Sterne, but nothing of their genius. The first, which alone is not wholly forgotten, which indeed was reprinted by Professor Henry Morley in 1886, is perhaps the most numby-pumby effusion that ever attained classical celebrity. His other writings include some Tory pamphlets, lives of Blacklock and Home, ninety-nine papers in the *Mirror* and *Lounger*, and four very weak plays. At least, he deserves recognition for his own

recognition of Burns, and as an early admirer of Lessing and of Schiller.

Mackenzie, WILLIAM LYON, Canadian agitator and journalist, was born in Dundee, 12th March 1795, emigrated to Canada in 1820, and in 1824 established the *Colonial Advocate*, first at Queenstown, then at Toronto. There his denunciations of the officials resulted in the partial destruction of his printing-office in 1826. In 1828 he was elected to the provincial parliament for York, but was expelled for libel on the Assembly, and was successively expelled and re-elected until finally the government refused to issue the writ. In 1832 he went to London with a petition of grievances from the Reformers of Canada, and while there secured the dismissal from office of the Attorney-general and Solicitor-general of Upper Canada. In 1834 he was elected the first mayor of Toronto, and in 1836 he started the *Constitution*, in which he attacked Sir Francis Head, the lieutenant-governor, for interference with the elections. In 1837 he published a virtual declaration of independence in his paper, headed a band of armed insurgents, and demanded of the lieutenant-governor a settlement of all provincial difficulties by a convention. This demand not having been granted, Mackenzie determined to arrest the lieutenant-governor and capture the military stores in Toronto; but being met by a superior force at Montgomery's Hill, 4 miles from the city, the insurgents were put to flight after a brief skirmish in which several were killed. Mackenzie and others effected their escape, and took possession of Navy Island in the Niagara River, where he established a provisional government. He was soon, however, compelled to break up his camp, and was afterwards sentenced by the United States authorities to twelve months' imprisonment in Rochester jail. On the proclamation of amnesty in 1849 he returned to Canada, and was a member of parliament from 1850 till 1858. Reforms more radical than those he contended for have since been granted. He died in Toronto, 28th August 1861. See the *Life* by his son-in-law, Charles Lindsay (2 vols. 1862).

Mackenzie River, in North America, has its origin, as the Athabasca (q.v.), in a Rocky Mountain lake in British Columbia, flows over 600 miles to Lake Athabasca, and 240 as the Slave River to Great Slave Lake (q.v.). It now assumes the name of Mackenzie River, and conveys the waters of the Great Slave Lake to the Arctic Ocean at Mackenzie Bay, after a final course which is reckoned at 1045 miles, making a total river-system of nearly 2590 miles. It drains an area of little less than 600,000 sq. m. The mouth of the river is closed from October to June by ice. The Mackenzie district itself is desolate and unfit for colonisation; but its great tributaries, the Liard and the Peace and Athabasca rivers, drain an immense fertile country, with abundance of petroleum (the fields have been reported the largest in the world), and some coal and lignite. The Mackenzie received its name from Sir Alexander Mackenzie (c. 1755-1820), by whom it was discovered in 1789. Sir John Franklin (q.v.) descended it in 1825. Since 1895 it gives name to a new north west territory of Canada.

Mackerel (*Scomber*), a genus of acanthopteran fishes of the family Scomberidae, which also includes the Tunny, Bonito, and Sucking Fishes. Members of the 'mackerel' family are pelagic forms of very extensive distribution. They are gregarious and predaceous, and are extremely active, the form of their bodies being eminently adapted for rapid gliding movements. Their muscles are richly supplied with blood and with nerves, and the temperature of their bodies is several degrees higher than in other fishes. The

genus *Scomber*, the mackerels proper, comprises seven species, distributed in almost all temperate and tropical seas, except off the American shores of the South Atlantic. The Common Mackerel (*S. Scomber*) is found as far south as the Canary Islands, and from Greenland to Cape Cod in Massachusetts. It is abundant off the British coast, is found in the Mediterranean, but is scarce in the Baltic. It is a very beautiful fish of elegant spindle-like shape. Its colour is a lustrous dark blue above, with wavy blackish transverse streaks and silvery below. The tail is crescent-shaped, and has a slight ridge or keel on each side. The snout is rather long, pointed, and compressed.

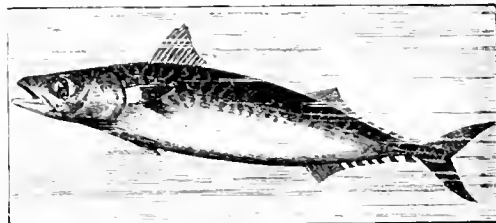

Common Mackerel (*Scomber Scomber*).

The mackerel is usually from 14 to 16 inches long, and about 2 lb. in weight, but it may attain a size of over 18 inches. Mackerels move about in shoals, approaching the coast at certain seasons either before or after spawning, or for purposes of feeding, following shoals of herrings, sprats, or pilchards, on which they prey. Their migrations are probably largely influenced by temperature. Early in the year they move from the deeper parts of the Atlantic towards the British coast. In May and June they are found off the Scilly Isles, whence some go up St George's Channel, but most proceed along the English Channel. They are very constant in the rate at which they travel during their migrations. The mode of capture varies with local circumstances. In spring and autumn drift-nets only are used; in summer, when the fish are near the shore, seine-nets are likewise employed. When the shoals are much broken up, hand-lines are used baited with various substances, such as a slip from another mackerel, a piece of a cuttle-fish, a thin rind of pork, worms, or indeed any glistening substance, such as a strip of coloured cloth moving quickly through the water. Hand-line fishing may be prosecuted at all hours of the day and night, but it is most successful in the morning and evening, and a smart breeze, termed a 'mackerel breeze,' is most favourable to its success. As food, the mackerel is very highly esteemed, but it taints very rapidly and loses flavour when kept. Owing to the rapidity of decomposition in hot weather, and the consequent injurious results to consumers, mackerel were allowed in 1698 to be sold in London either before or after divine service on Sundays, an enactment that appears not to have been repealed. The introduction of steamboats as 'carriers' instead of sailing-vessels has proved highly beneficial to the mackerel industry and to the general public. In the beginning of 1890 a first consignment of cured mackerel was sent from Cape Town to Princetown, Massachusetts. Off the south coast of England mackerel seem to spawn about May or June. Sars states that eggs are deposited some leagues from the shore and at the very surface of the waves, where large numbers of these fish may be met with engaged in spawning. The eggs float on the surface. In suitable circumstances the young grow rapidly.

Another species, the Spanish or Coly Mackerel (*S. colias*), is found in Europe in the Mediterranean,

rarely on the south coast of England, and occurs from Nova Scotia to Cape Hatteras. It attains a weight of 4 or 5 lb., and unlike the common mackerel possesses an air-bladder. The Seal (q.v.) is sometimes called Horse Mackerel; the Mackerel Midge is a small Rockling (q.v.).

Mackinaw. See MICHIGAN (LAKE).

McKinley, WILLIAM, twenty-fourth president of the United States, was born 29th Jan. 1843, at Niles in Ohio, and served in the Civil War, retiring in 1867 as major to Canton, where, after a period of study, he practised law. He was elected to congress in 1877, and repeatedly re-elected. In 1891 he was made governor of Ohio, his name having ere this been identified with the high protective tariff carried in the McKinley Bill of 1890, though subsequently modified by the Democrats in 1894. Chosen Republican candidate for the presidency in 1896, he conducted an exciting contest with W. J. Bryan, who advocated the cause of free silver, payment of debts in silver dollars, the repression of monopolies, and was understood to favour labour at the expense of capital. A large section of the Democrats, 'Gold Democrats' or 'Sound Money Democrats,' in spite of their dislike to McKinley's policy on many points (including his protective tariff), strongly supported him as against Bryan; and McKinley secured (November 1896) a majority of more than a hundred in the electoral college, being regarded as the representative of non-repudiation, a gold standard, and the interests of capital generally. For the war with Spain, see CUBA. In 1900 he again defeated Bryan by an even bigger majority.

Mackintosh. See INDIA-RUBBER.

Mackintosh, SIR JAMES, philosopher, was born at Aldourie in Inverness-shire, October 24, 1765. Having studied at King's College, Aberdeen, and then medicine at Edinburgh, he settled in London, for some time supporting himself and his young wife by writing for the newspapers. The first work that brought him into notice was his *Vindictive Gallia* (1791), in reply to Burke's *Reflections on the French Revolution*. Fox, Sheridan, and other leading Whigs sought the author's acquaintance; and when the association of the 'Friends of the People' (q.v.) was formed he was appointed secretary. He was called to the bar in 1795, and ere long attained high eminence as a forensic lawyer. In 1799 he delivered a brilliant series of lectures on the law of nature and of nations before the benchers of Lincoln's Inn; and his defence of Peltier (1803), charged with a libel on Bonaparte, was a splendid triumph. In 1804 he was knighted, and appointed recorder of Bombay, and in 1806 judge of the Admiralty Court; here he spent seven years, entering parliament on his return as Whig member for Nairn (1813). He was professor of Law in the college of Haileybury from 1818 to 1824, and in 1830 became a member of the Board of Control under the Grey ministry, and spoke in favour of the Reform Bill. He died not long after, on the 22d May 1832. His *Dissertation on the Progress of Ethical Philosophy* (1831), written for the *Encyclopædia Britannica*, although very incomplete, shows the admirable powers of the author. For Lardner's *Cyclopædia* he wrote a brief but excellent survey of the History of England. A mere fragment of a great projected work, entitled *A History of the Revolution in England in 1688*, appeared after his death.

A collection of Mackintosh's miscellaneous works was published in 3 vols. in 1854. See the *Memories* by his son (2 vols. 1835), and the essays of Macaulay and De Quincy.

Macklin, CHARLES, actor, was born 1st May 1690, according to his biographer (Macklin used to say in 1699), the son of an Irish gentleman name,

McLaughlin, who commanded a troop of horse for King James at the Boyne two months later, and lost his estates in consequence. After a wild, unsettled youth, in which he was by turns potboy, college servant, and stroller, he played for a number of years in Bristol and Bath, till his brogue was worn down, and in 1733 was engaged for small parts at Drury Lane. He steadily rose in the public favour, till in 1741 he appeared in his great character, Shylock: Pope said of it, 'This is the Jew that Shakespeare drew.' From this time he was accounted one of the best actors, appearing with nearly equal success in tragedy or comedy, in passion or buffoonery, for nearly half a century. His last performance was at Covent Garden in May 1789, when he broke down; but he survived, with an annuity of £200, till 11th July 1797. He was generous, high-spirited, and honourable, but somewhat irascible: in 1735 he killed a brother-actor in a quarrel over a wig, and was tried for murder; and frequently afterwards he was engaged in disputes and actions at law. He wrote a tragedy, and several farces and comedies: of these *Larcibus Mæde* (1759) and *The Man of the World* (1781) have been printed; in the latter his own part was Sir Pertinax MacSycophant. See his *Memoirs*, by J. T. Kirkman (2 vols. 1799), and the Life by E. A. Parry (1891).

Macknight, Dr JAMES, an eminent divine of the Church of Scotland, was born at Irvine, in Ayrshire, 17th September 1721; studied at Glasgow University, and afterwards at Leyden, in Holland; and in 1753 was ordained minister of the parish of Maybole. In 1769 he was translated to Jedburgh, and thence to Edinburgh in 1772, where he died, 13th January 1800. Macknight was a superior scholar, a liberal, wise, and prudent ecclesiastic, and a respectable writer on Scripture subjects. His principal works are *Harmony of the Four Gospels* (1756); *The Truth of the Gospel History* (1763); and *A New Translation of the Apostolical Epistles, with Commentary and Notes* (1795).

Mackonochie, ALEXANDER HERRIOT, priest, was born at Fareham in Hampshire, 11th August 1825, the son of a Scotch East Indian colonel. He was privately educated at Bath and Exeter, studied awhile at Edinburgh University, and in 1845 went up to Wadham College, Oxford. In 1848 he took a second-class in classics, and next year was ordained to a curacy at Westbury, removing in 1852 to Wantage, and in 1858 to St George's-in-the-East. In 1862 he became the first vicar of St Alban's, Holborn—the small but crowded slum where for twenty years he did a great work that lives after him. His prosecution (or persecution) by the Church Association for ritualistic practices commenced in 1867; and at last in 1882, in accordance with the dying wish of Archbishop Tait, he sought to withdraw from further conflict by resignation. He accepted the charge of St Peter's, London Docks; that, too, a twelvemonth later he had to resign. His health broke down; and on 15th December 1887, during a visit to the Bishop of Argyll at Ballachulish, he lost his way in the Mamore deer-forest, and was found two days later lying dead in the snow, a deerhound and a Skye terrier guarding him. He rests in the St Alban's burial-ground at Woking. See his Life by Mrs Towle (1890).

Maclaurin, COLIN, mathematician, was born at Kilmodan, Argyllshire, in 1698. He graduated M.A. at Glasgow in 1713, and four years later obtained the professorship of Mathematics in Marischal College, Aberdeen. In 1719 he visited London, and was admitted to the Royal Society. Here he published his *Geometria Organica* (1719), an elaborate treatise on the description of curves.

He afterwards visited France as tutor to Lord Polwarth's son, and while there wrote a dissertation on the percussion of bodies, which gained the prize of the Academy of Sciences in 1724; while sixteen years later he divided with Euler and Bernoulli its prize for an essay on the flux and reflux of the sea. The following year he was appointed, on the recommendation of Newton, assistant to James Gregory, professor of Mathematics in the university of Edinburgh, and soon after succeeded him in the chair. In the labour of preparing trenches and barricades to defend Edinburgh against Prince Charlie's army he took too active a share for his health, and died of dropsy June 14, 1746. Maclaurin's writings gave a strong impetus to the study of mathematical science in Scotland. His *Treatise on Fluxions* (1742), written in defence of Newton's discoveries against the attack of Berkeley, was the first work in which the principles of fluxions were logically arranged, and formed a contribution of the greatest importance to the theory of the tides and the figure of the earth. The *Treatise on Algebra* (1748) was left incomplete, as was also the *Account of Sir Isaac Newton's Philosophical Discoveries* (1748), containing explanations of all Newton's discoveries, the optical ones excepted. Many papers appeared in the *Philosophical Transactions*.

Maclé, a term employed in mineralogy to designate what are also called *twinned crystals*, which are crystals united according to some precise law, yet not having their faces and axes parallel, so as to render the one a mere continuation of the other. In some maclés the axes are parallel; in some, they are inclined at an angle. Crystallisation in maclés is very characteristic of some minerals.—*Maclé* is also the name of the variety of Andalusite (q.v.) called Chistolite, a silicate of alumina, containing a little magnesia and oxide of iron. Maclé has been much used for making beads for rosaries, &c.

M'Lennan, JOHN FERGUSON, a strikingly original and suggestive writer on primitive civilisation, was born at Inverness, 14th October 1827. He graduated at King's College, Aberdeen, in 1849, and then proceeded to Trinity College, Cambridge, which he left in 1853 to join the Scottish bar in 1857. But he cut short the practice of his profession in his zeal for the study of the usages and customs of early civilisation. The chief fruit of his labours appeared in *Primitive Marriage* (1865), in which he emphasises the importance of the patriarchal theory of marriage amongst savage peoples, and in papers in the *Fortnightly Review* (1869-70) on totemism. His book, after being enlarged and the argument strengthened by new evidence, was issued under the new title of *Studies in Ancient History* in 1876. M'Lennan further defended his views as against the patriarchal theory of Sir Henry Maine in *The Patriarchal Theory*, left incomplete at the author's death, but finished and edited by his brother Donald in 1885. He also wrote a *Life of Thomas Deaconmond* (1867) and papers on 'The Levirate and Polyandry' (1877). Draftsman of parliamentary bills for Scotland in 1872-75, he died 16th June 1881. A second series of *Studies in Ancient History*, edited by his widow and A. Platt, appeared in 1896.

Macléod, NORMAN, a divine of the Church of Scotland eminent for his pulpit oratory, his writings, and his liberal Christianity, the son of a parish minister, was born at Campbeltown, Argyllshire, June 3, 1812. He was educated at Campbeltown and Campsie, to which his father had been translated, attended Glasgow University, and entering the church became minister of London, in Ayrshire (1838-43); of Dalkeith (1843-45); and of

the important Barony Church, Glasgow, from July 1851 till his death, June 16, 1872. He received the degree of D.D. in 1858, and was appointed one of the Queen's Chaplains in Scotland, the Queen valuing highly his sermons, sympathy, and advice. An utterance of his on the Sabbath question in 1865 started his brethren and the public, and he was threatened with prosecution; but wiser counsels prevailed. In 1869 he was moderator of the General Assembly, and was designated Dean of the Chapel Royal and Chaplain of the Order of the Thistle. In 1845 he visited Canada as a church deputy; he was in Palestine in 1864-65, and in India in 1867, on mission business for the Church of Scotland. One of the most eloquent and powerful addresses he ever delivered was that on missions before the General Assembly, after his return. From 1850 to 1859 Macléod edited the *Edinburgh Christian Magazine*, for a year the *Christian Guest* (1860), and from 1860 till 1872 *Good Words*, to which he contributed tales, essays, verses, sermons, most of which were reprinted in book-form. Full of healthy life and human sympathy himself, his writings show shrewd observation, lively description, and good-humour; his tales are lacking on the constructive side. He possessed a large, simple, childlike nature, full of tenderness, and was broad and catholic in his sympathies, which bound him to humanity at many points. He published *The Earnest Student* (1854), *Deborah* (1857), *Daily Meditations* (1861), *The Gold Thread* (1861), *The Old Lieutenant* (1862), *Parish Papers* (1862), *Wec Dara* (1864), *Simple Truth* (1866), *Eastward* (1866), *Reminiscences of a Highland Parish* (his grandfather's parish of Morven, 1867), *The Starling* (1867), *Peeps at the Far East* (1871). See *Memoir* (1876) by the Rev. Donald Macléod, and articles by Strahan (*Contemporary Review*, July 1872) and Dean Stanley (*Good Words*, 1872).

Maclise, DANIEL, painter, the son of a Highland soldier named McLeish, was born at Cork in January 1806 (not 1811) and baptised 2d February, entered the school of the Royal Academy, London, in 1828, soon exhibited at the Academy, and in 1833 made himself famous by his 'All-Hallow Eve.' His later pictures are many of them familiar by engraving such as 'The Banquet Scene in Macbeth' and 'Scene from Twelfth Night' (1840), 'Play Scene in Hamlet' (1842), and his design of 'Shakespeare's Seven Ages' (1848), 'The Gross of Green Spectacles' (1850), 'Caxton's Printing-office' (1851). The frescoes—each 45 feet long and 12 feet high—in the Royal Gallery of the House of Lords, depicting 'The Meeting of Wellington and Blücher on the Evening of the Battle of Waterloo' and 'The Death of Nelson at Trafalgar,' were admitted to be the finest mural paintings hitherto executed in Britain. Numerous good engravings of them are current. The most noteworthy pictures exhibited by Maclise, after the completion of these great works, were 'Othello,' 'Desdemona,' and 'Opheelia' (1867), 'The Sleep of Duncan' and 'Madeline after Prayer' (1868), 'King Cophetua and the Beggar Maid' (1869), 'The Earls of Desmond and Ormond,' posthumously exhibited in 1870, in which year he died on 1st April. The sketches by him of his contemporaries, published in *Fraser's Magazine* during 1830-38, were republished in 1874 and 1883. See the *Memoir* by O'Driscoll (1871).

Macmahon, MARIE EDMÉ PATRICE MAURICE DE, Duke of Magenta, marshal of France, descended from an Irish Jacobite family, was born at Sully, near Antun, 13th June 1808. Entering the army, he saw much active service in Algeria, especially distinguishing himself at the storming of Constantine (1837), commanded the

division that stormed the Malakoff at Sebastopol in 1855, and took a conspicuous part in the war against the Kabyles in Algeria (1857-58) and in the Italian campaign of 1859, winning a marshal's baton and the dignity of Duke of Magenta for the decisive part he took in the battle of that name. He was nominated governor-general of Algeria in 1864. In the Franco-German war of 1870-71 he had command of the first army corps, but was defeated at Wörth, and wounded and captured at Sedan. On the close of the war he was made commander of the army of Versailles, with which he suppressed the Commune. In 1873 he was elected president of the republic for a period of seven years, with some hope that the restoration through him of the Bourbons might be secured. For his sympathies were, and continued to be, conservative, and at times reactionary, and, although he pursued no aggressive policy, he gradually became estranged from the Republicans. Rather than dismiss some of his old comrades in arms he preferred to resign, 30th January 1879. He afterwards lived in retirement, and died 17th October 1893.

Macmillan, DANIEL, was the son of a small farmer, and was born at Upper Corrie, Arran, 13th September 1813. His brother Alexander was born at Irvine, 3d October 1818, survived Daniel for nearly forty years, and died 25th January 1896. After serving a seven years' apprenticeship (1824-31) under a book-seller at Irvine, Daniel went to Glasgow in 1831; was engaged with Johnson, Cambridge (1833-37), and with Seeley, London (1837-43). He was joined by his younger brother Alexander, who had been keeping a school at Nitshill, near Paisley, and a small shop in Aldersgate Street in London was opened under his charge in 1843. Partly through the kindly interest of Archdeacon Hare the business of Mr Newby, Cambridge, was taken over by the brothers in the same year, and Mr Stevenson's business there was acquired for £6000 in 1845, with the assistance of fresh partners. As the brothers showed insight and knowledge of books their business grew rapidly, and by 1856 success was secured. The books that helped the young firm most largely were the works of Kingsley, Maurice, and the educational and university volumes. Daniel died 27th June 1857. He had a high ideal of the book-selling business: 'As truly as God is, we are his ministers and help to minister to the well-being of the souls of men.' Alexander Macmillan (1818-96) was appointed publisher to Oxford University in 1863, and in the same year the business was removed to London. *Macmillan's Magazine* first appeared in 1859, and now the catalogue of the firm embraces works by the most eminent names of the day in all departments of literature. See the Life by F. Hughes (1882).

Macmillanites. See CAMERONIANS.

Mâcon (*Matisco* of Caesar), the capital of the French department of Saône-et-Loire, on the right bank of the Saône, 41 miles by rail N. of Lyons. A dull, modernised place, it has a twelve-arch bridge, with a view of Mont Blanc; a fragment of an old cathedral, demolished at the Revolution; the fine Romanesque church of St Pierre (rebuilt 1866); and a statue of Lamartine, who was born here. It carries on an extensive trade in wines known as Macon, like but lighter than Burgundy, as well as in corn, cattle, &c., and has manufactures of watches, brass, faience, &c. Pop. (1872) 16,614; (1891) 18,497.

Macon, capital of Bibb county, Georgia, on the Ocmulgee, stands among forest-clad hills, at the head of navigation, 103 miles SSE. of Atlanta, on six lines of railway. It is the seat of Mercer University (Baptist), a Roman Catholic college, a Wesleyan girls' school, and an academy for the

blind; has several foundries, flour and lumber mills, cotton factories, &c., and ships large quantities of cotton. Pop. (1880) 12,749; (1890) 22,746.

Macpherson, JAMES, notorious as the 'translator' of the Ossianic poems, was born in 1738 at Ruthven, in Inverness-shire. After finishing his studies at King's College, Aberdeen, he became a schoolmaster in his native village, published a poem entitled the *Highlander* in 1758, contributed about the same time verses to the *Scots Magazine*, and in the following year, having met with 'Jupiter' Carlyle and John Home, the author of *Douglas*, he showed them some fragments of Gaelic verse, with 'translations' of the same. These (sixteen in number) appeared in 1760, and excited so much interest that the Faculty of Advocates in Edinburgh subscribed money to send Macpherson on a tour through the Highlands for the purpose of collecting more of the same. The quest was successful, but the unsatisfactory statements of Macpherson about his originals and the place where he made his discoveries excited grave and well-grounded suspicions. Some MSS. undoubtedly he found, but what he published as their contents was something very different from these. The result of his labours was the appearance at London, in 1762, of the so-called poems of Ossian (q.v.), under the title of *Fingal, an Epic Poem, in Six Books*; and in 1763, of *Temora, an Epic Poem, in Eight Books*. A storm of controversy soon arose in regard to their genuineness, which can hardly yet be said to have entirely subsided, although the general verdict is one unfavourable to Macpherson. Dr Johnson's vigorous denunciation of the imposture so inflamed Macpherson that he threatened personal violence to the old man, who replied with characteristic fearlessness: 'Any violence offered me I shall do my best to repel; and what I cannot do for myself, the law shall do for me. I hope I shall never be deterred from detecting what I think a cheat by the menaces of a ruffian.' These poems were, however, the making of Macpherson in a worldly point of view. He was appointed in 1764 surveyor-general of the Floridas with a salary for life, and in 1779 agent to the Nabob of Arcot—a very lucrative office; entered parliament in the following year as member for Camelford, sat for ten years, and then retired to the estate of Bellville which he had purchased in Inverness-shire, and where he died February 17, 1796. His body was actually interred at his own request and expense in Westminster Abbey. He wrote historical compilations, and a wretched prose translation of the *Hoad*. See his *Life and Letters* by Bailey Saunders (1894).

Macquarie, a tributary of the Darling (q.v.), a river and a port of Tasmania, a port in New South Wales, and a small island in the South Pacific; from General Lachlan Macquarie, governor of New South Wales from 1809 to 1821.

Macrauchenia (Gr., 'long-necked'), a genus of South American fossil herbivorous animals, forming a connecting-link between the Palæotherium (q.v.) and the camel family. In form they nearly resembled the llama, but were as large as a hippopotamus.

Macready, WILLIAM CHARLES, actor, was the son of William McCready (so he spelt his name), actor and provincial manager. His mother, whose maiden name was Birch, was an actress. While the elder Macready was fulfilling an engagement at Covent Garden, William Charles was born in Mary Street, Easton Road, on 3d March 1793. In 1795 his father became manager of the Birmingham Theatre, and Macready was sent to Rugby, where he entered in 1803. He was intended

for the bar; but his father's managerial speculations proving unsuccessful, he was forced to adopt the stage as his profession. He made his first appearance at Birmingham on 7th June 1810, playing Romeo, and for six years remained in the provinces. On 16th September 1816 he made his London debut, playing Orestes (*Distress Mother*) at Covent Garden. His reception by the critics and public was friendly; but he was for a long time very unfortunate in being cast for unsympathetic parts, one of the few exceptions being *Rob Roy*, in which he made a great hit, and of which he was the original actor in London. For many years he fought a fairly equal fight against Kean, Young, and Charles Kemble; but it was not till 1837 that he really took his position as leading English actor. On 30th September 1837 he inaugurated his famous Covent Garden management, during which he did much good service to the English stage. Surrounded by such players as Miss Faucit, Samuel Phelps, James Anderson, Mr and Miss Vandenhoff, Miss Priscilla Horton, and Mrs Warner, he produced Shakespeare's plays in worthy fashion, and did much to elevate and reform the theatre. For two seasons he managed Covent Garden, but abruptly gave it up; then, after two years' interval, took Drury Lane, which he managed from December 1841 to June 1843. After this time he never settled in London, but played in the provinces, in Paris, and in America. His last visit to the United States was marked by the terrible riots which arose out of the ill-feeling borne by the American actor Forrest to Macready. A riotous mob trying to break into the Astor Place Theatre for the purpose of maltreating Macready was fired upon by the military, and some twenty lives were lost (10th May 1849). On 26th February 1851 Macready took his farewell of the stage, at Drury Lane, in his great part of Macbeth, and passed his remaining years in placid retirement at Sherborne, Dorsetshire, and at Cheltenham, where he died on 27th April 1873. As an actor Macready endeavoured to combine the dignity of the Kembles with the naturalness of Kean. If not of the first rank, he was yet an actor of great power, and specially distinguished himself in Macbeth, Lear, Iago, King John, Cassius, and Henry IV. In Virginius, Werner, Richelieu, and Claude Melnotte he was also greatly successful.

See Macready's *Reminiscences and Diary* (1875); Lady Pollock's *Macready as I knew Him* (2d ed. 1885); and a memoir by William Archer ('Eminent Actor,' series, 1890).

Macrobius, AMBROSIVS THEODOSIVS, a Latin grammarian who flourished about the beginning of the 5th century. He appears to have been by birth a Greek, but literally nothing whatever is known of his life, not even whether he was a Christian or a pagan. Two of his works are extant—a commentary on Cicero's *Somnium Scipionis*, and *Saturnalia Convivialium Libri Septem*, a series of historical, mythological, antiquarian, and critical dialogues at third hand. There are editions by Jan (1848-52) and Eysenhardt (2d ed. 1893), and studies by Linke (1880) and Wissowa (1880).

Macrocosm. See MICROCOSM, PARACELSUS.

Macroon, a market town of Ireland, on the Sullane, 24 miles by rail W. of Cork. Pop. 3099. Near Macroon is a seat of the Earl of Bantry, constructed out of an old castle of King John's time.

Mactra, a genus of bivalve molluscs, with somewhat triangular equal-valved shells. They are active animals, ploughing their way through the sand either on the shore or at slight depths, and are able like cockles to take considerable leaps. Two common North American species, *M. solida* and *M. aculis*, known as hen-clams, surf

clams, &c., are sometimes eaten, while some small

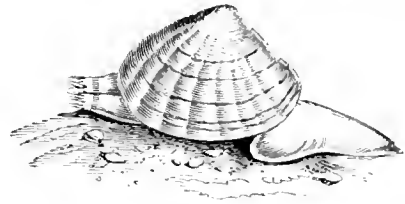

Mactra.

British species—e.g. *M. subtruncata*—are said to be gathered for feeding pigs.

MacWhirter, JOHN, artist, was born in 1839 near Edinburgh. Apprenticed early to a bookseller and publisher, he ran away in disgust, and commenced his artist's life. His early studies of wild-flowers at home and abroad were selected by Ruskin as examples for his Oxford class. In 1864 he was elected Associate of the Scottish Academy, in 1879 A.R.A., and in 1893 R.A. He excels in depicting Highland scenery, but one of his most admired works is a view of Constantinople and the Golden Horn (1889). As favourites among his numerous pictures may be mentioned 'The Vanguard,' 'The Lady of the Woods,' 'The Three Graces,' and 'Out in the Cold.'

Madagascar, the third largest island in the world, is situated to the SE. of Africa, and is about four times as large as England and Wales. It is in 12° 2'—25° 35' S. lat. and 42°—51° 40' E. long.; length, 978 miles; greatest breadth, 350 miles; area, about 230,000 sq. m. Although frequently visited by Europeans since the beginning of the 16th century, Madagascar is yet but imperfectly explored. The coasts were carefully surveyed by Captain W. F. W. Owen, R.N., 1823-25; but until lately there has been a great lack of accurate knowledge as to the geography of the interior. Much light has, however, been thrown upon this by a distinguished French savant, M. Alfred Grandidier, who, between 1865 and 1870 explored the island and crossed it in several directions. Since then numerous journeys have been made by members of the London Missionary Society and other missions at work in the country; and the information thus obtained was embodied in a large map of Madagascar prepared in 1879 by Rev. Dr Mullens. A later map, brought up to the present state of our knowledge of the island, was issued in 1889 by Pere Roblet, S.J.

Madagascar consists, as regards its physical geography, of two great divisions—viz. (1) an elevated interior region, raised from 3000 to 5000 feet above the sea; and (2) a comparatively level country surrounding the high land, not much exceeding 600 feet in altitude, and most extensive on the west and south, although there are very lofty mountains extending to the south-eastern extremity of the island. The first of these is composed chiefly of Primary (gneiss and other crystalline) rocks, with enormous quantities of red clay-like earth, consisting of decomposed gneiss. It is a mountainous region, there being very little level ground except in the river-valleys, and some extensive and fertile rice-plains, the dried-up beds of ancient lakes. This interior highland comprises nearly half the total area of the island, and, although central, lies more to the north and east, the watershed running down the eastern side of the island at no great distance from the coast. From this upper region rises the highest mountain-mass, that of Ankaratra, probably an ancient volcano, whose summits are nearly 9000 feet above the sea-level. The lower region of Madagascar is fertile and well wooded,

especially on the eastern side of the island, though a large district in the south is barren. The western side appears to consist of secondary strata of the Cretaceous and Jurassic periods, and here the extensive plains are broken up by three prominent lines of mountain running north and south. From the south-east to the north-west and north a probably almost continuous series of extinct volcanic craters has been traced. These are very numerous near Lake Itasy (19° S. lat. and 47° E. long.), and also in the Betáfo district, about 50 miles farther south. There are hot springs in many parts of the island. The chief rivers flow west and north-west, and there are many fine bays and harbours on the north-west coast. The largest lake is the Alaotra in the Antsihánaka province, and a remarkable chain of lagoons extends for about 300 miles along the east coast, south of Tamatave, needing only about 20 miles of canal to connect them all into a continuous waterway.

All round the island is a nearly unbroken belt of dense forest, varying from 10 to 40 miles across, and most largely developed in the north-east. The flora of Madagascar is, therefore, very rich and varied, and contains large numbers of trees producing valuable timber, concessions for working which have lately been granted to several European companies. The flora is divided by Rev. R. Baron, F.L.S., into three regions, the eastern, central, and western, the central region including the elevated interior plateaus. Amongst the most characteristic forms of vegetation are the Traveller's Tree (*Ravennia madagascariensis*), the Roftia Palm (*Raphia ruffia*), the Lace-leaf (*Ocrotandra fenestralis*), the Beef-wood Tree (*Casuarina equisetifolia*), several species of pandanus and bamboo, and numerous peculiar orchids and ferns. Three-fourths of the species and one-sixth of the genera of the plants are endemic to Madagascar, showing (besides other facts to the same effect) that the island is of very great antiquity. About 4100 indigenous species are now known in Madagascar, and there is one natural order, Chlanaceæ, with twenty-four species, confined to the island.

The fauna of Madagascar contains several exceptional and ancient forms of life, comprising many species and even genera known nowhere else; but, considering its proximity to Africa, the country is markedly deficient in the larger carnivora and in ungulate animals. It is specially the home of the Lemuride, there being about thirty species of this family of Quadrumina, including the very curious Aye-aye (q.v., *Chiromys madagascariensis*). It is also the chief habitat of the chameleons, and especially of those species with curious processes on the head, about half of all the known species in the world being found in the island. About 240 species of birds are found in Madagascar, and of the 150 land-birds 35 genera and 129 species are peculiar to it, many of them being unlike any other living forms and of remote affinities. The remains, in a sub-fossil state, of an immense struthious bird (*Epporais maurinus*), as well as of some smaller allied species, have been found in several places on the southern coast, together with its eggs, the largest known (12½ in. × 9 in.). Fossil remains of gigantic tortoises have also been discovered, as well as of an extinct hippopotamus, but smaller than that now living in Africa.

The Malagasy people appear to be mainly derived from the Malayo-Polynesian stock, with which they have numerous affinities; and they have numerous points of connection with the Melanesian tribes, from which the darker element in the inhabitants of Madagascar is probably derived. There is also an admixture of African blood, especially on the western side of the island; and there is an Arab element both on the north-

west and south-east coasts. It is further believed that there are traces of an aboriginal race called Vazimba, who appear to have been driven out of the central provinces by the Hova, and whose descendants are still found in one part of the west coast. Accounts are also given of a tribe of people who live in the woods, chiefly on the trees. The Hova, the most advanced, civilised, and intelligent Malagasy tribe, inhabiting the central province of Imérina, and, since the beginning of the 19th century, the dominant race, are probably the latest immigrants and the purest Malayan in origin. Other important tribes are the Bet-sileo (southern central), Bára (still farther south), Tanála (south-east forest), Betsimisáraka (east coast), Sihanaka (north-east central), and Sakaláva (along the entire west coast). The eastern and western coast tribes have numerous subdivisions. All the coast peoples appear to be closely connected with each other in language; but, although there are many dialectic differences, the language of the whole country is substantially one, and is evidently nearly allied to those of the Malayan and Melanesian islands. The population of Madagascar is variously estimated at from 2,500,000 to 5,000,000; probably it is intermediate between these two figures.

The Malagasy, not having had their language reduced to a written form until the early part of the 19th century, have no ancient literature; but their numerous proverbs, songs, fables, and folk-tales, and their oratorical abilities, as well as the copiousness of their language, give ample proof of their intellectual acuteness. In their heathen state they are very immoral and untruthful, and cruel in war; but they are also courageous, affectionate, and firm in friendship, kind to their children and their aged and sick relatives, obedient to the law and loyal, very courteous and polite, and most hospitable. While retaining some traditions of a Supreme Being, they practised (and, except in the more enlightened parts of the central provinces, still practise) a kind of fetichism, together with divination, curious ordeals, and ancestor-worship.

The capital, Antanárivo, is situated centrally in the island, but nearer the eastern side. It has a population of about 100,000, and contains many large and handsome buildings, including the royal palaces, residences of the prime minister and chief nobles, four stone memorial churches, as well as many others of brick belonging to the London Missionary Society, Anglican and Roman Catholic cathedrals, several colleges and high schools, hospitals and dispensaries, an observatory, court of justice, mission printing presses, &c. The chief ports are Tamatave, on the east coast, and Mojangá, on the north-west. Ambohimanga in Imérina, and Fianarantsoa in Betsileo, are important places in the interior.

The principal exports (£165,000 per annum) of Madagascar are cattle, hides, gum-copal, india-rubber, rafia bast, and rice, and, more recently, ebony and other valuable woods; coffee, sugar, and vanilla are also being cultivated by Creole settlers. The chief imports (£162,000 per annum) are cotton goods, ironmongery, crockery, and rum. The principal trade is from the eastern ports to Mauritius and Reunion, and there is also now an increasing trade from the western side of the island with the South African colonies. The soil of the coast plains, especially of the eastern side, is fertile, and could supply large quantities of all tropical productions. Iron is abundant, especially as magnetite, and also as hematite and ironstone, and the Malagasy are skilful in the smelting and working of this as well as other metals. Copper apparently exists in great quantity in certain districts, and there also tin is said to be found. Galena is found abundantly near Mount Ankaratra, and from

this lead for bullets is obtained, and silver is being extracted from it. Gold of excellent quality has recently been found in many parts of the interior, and is now being worked by foreign capitalists as well as by the native government. Sulphur occurs in beds near some of the extinct volcanoes. There are as yet no roads or wheeled vehicles in Madagascar, so that the country is in some respects very backward, although there is no lack of manual skill among the people, who excel in weaving, in straw-work, and in carpentry, as well as in the working of gold and silver.

Madagascar was known to the early Greek geographers Ptolemy, Arrian, and Marcian under the name of *Mantliosis*; and the Arabian geographer Ebrisi apparently describes it under the name of *Chechezat*. The island was certainly known to and visited by Arab merchants at least a thousand years ago, and settlements were formed by them, as well as by Indian traders, in very early times; indeed the Arabs have left indelible traces of their influence upon the language, civilisation, and superstitions of the Malagasy. Madagascar is first mentioned under its present name by Marco Polo as *Madaigascar* or *Mogastar*; but the first European who saw the island appears to have been the Portuguese Fernam Soares in 1506. To the Portuguese, accordingly, was owing the name by which Madagascar was long known in European maps, *São Lourenço*, but they made no permanent colony there. The Dutch formed settlements for a short time; and the French made persistent efforts for nearly two centuries to maintain military posts on the east coast, but without any permanent success. But they still retain the little island of Ste Marie (east coast); in 1840 they obtained the island of Nosibe (north-west coast); and in 1883 they went to war with the Malagasy on various pretexts, hostilities being carried on in a desultory fashion for about two and a half years. Eventually a treaty was concluded by which the Bay of Diego Suarez, at the extreme north of Madagascar, was ceded to France, together with the right to place a Resident and other officers at the capital, and other officials at various ports and other places. In 1890 the English government formally acknowledged the French protectorate of Madagascar, but this has never been agreed to by the Malagasy government, and will probably not be acknowledged by them.

Up to the middle of the 17th century Madagascar was divided into a number of independent chief-taincies; about that time, however, the warlike Sakalava made themselves masters of the western half of the island, as well as of several interior provinces. But in the early part of the 19th century the Hova, led by two energetic chiefs, Iamboasalama, afterwards known as Andriamponimerina, and his son Radama I., threw off the Sakalava yoke, and with the aid of English arms and discipline, made themselves virtually kings of Madagascar. They conquered the eastern, north-western, and central provinces; but the Hova authority is still only nominal in some parts of the island. (In 1889, however, the turbulent tribes of the south-west were brought into submission.) Radama abolished the export slave trade, and gave encouragement to English missionaries, who commenced work at his capital in 1820. They reduced the language to writing, gave the people the beginnings of a literature, formed numerous schools, founded Christian churches, and introduced many of the arts of civilised life. But the accession of Queen Ranavalona I., in 1828 gradually led to repressive measures; the missionaries were obliged to leave in 1836, and a severe persecution of the native Christians ensued, in which numbers perished. Europeans generally were also for some time excluded from the island. The queen's decease in

1861 put an end to this period of terror, and Madagascar was reopened to Europeans at the accession of her son Radama II. Owing to the young king's follies and to intrigues with the French he was put to death in 1863, and his wife Rasoherina placed on the throne. During her reign (1863-68) steady advances were made, and treaties of commerce concluded with England, France, and America. Queen Ranavalona II., who succeeded, and her husband, the prime-minister, identified themselves with Christianity, which was becoming an important power in the country. The queen and her husband and many of the nobles were baptised; and the burning of the royal idols in the following year (1869) caused almost the whole population of the central provinces of Imerina and Betsileo to put themselves under instruction. Since that time about 1600 Protestant Christian congregations have been formed, together with about 1300 schools, with 100,000 scholars, and 280,000 adherents. (It is difficult to obtain any reliable statistics of the Roman Catholic mission; probably their numbers amount to about a fifth or sixth of the above, while of the preceding figures about five-sixths belong to the united missions of the London Missionary Society and the Friends, the others to the Norwegian Lutheran and the English Episcopal missions.) Several colleges and training institutions, as well as hospitals and dispensaries, have been established; and the mission presses issue about 220,000 copies annually of various publications. In 1879 all the African slaves in the country were set free. Queen Ranavalona III., born in 1862, succeeded in 1883. After the accession of Ranavalona III. in 1883, the French pressed claims to a protectorate, which after the occupation of Tamatave were in 1885 conceded. Difficulties led finally to the French expedition in 1895, which, after fearful losses from fever and imperfect commissariat, forced its way to Antananarivo, with almost no resistance from the Hovas. The French protectorate and France's right to military occupation were fully acknowledged. But the French failed to acquire full control over the island, and in 1896 a military governor superseded the civil governor.

See Flacourt's *Histoire de Madagascar* (1661); *History of Madagascar* (1838); *Three Visits to Madagascar* (1858); and *The Martyr Church* (1870), all by W. Ellis (q.v.); the present writer's *Madagascar and its People* (1870); *The Great African Island* (1880), and *Madagascar Bibliographie* (1885); Grandidier's *Histoire géographique, naturelle, et politique de Madagascar* (28 4to vols., 1876 et seq.); *Guide de l'Annuaire à Madagascar* 3 vols., 1900; other French books by Blanchard (1875), Gontier (1895), and Catat (1896); and English by Oliver (1885), Cousins (1895), Maude (1895), Knight (1896).

Mad-apple, a name sometimes given to the Apple of Sodom (q.v.), to the produce of the Egg-plant (q.v.), and to a kind of Galls (q.v.).

Maddalo'ni, a city of Italy, 17 miles by rail NNE. of Naples. Pop. 17,072.

Madden, SIR FREDERICK, an eminent English antiquary, born in Portsmouth in 1804, employed in the British Museum first as assistant keeper, from 1837 as keeper, in the department of MSS. He was knighted in 1832, and gazetted as one of the gentlemen of the privy chamber. In 1866 he retired from his office in the British Museum, and he died in London, 8th March 1873. Madden edited many works of literary or historical interest, including *Havelok the Dane* (1833), *William and the Werewolf* (1832), the early English versions of the *Gesta Romanorum* (1838), *The Wycliffite Version of the Holy Scriptures* (1830), *Layamon's Beut* (1847), and the *Historia Anglorum* of Matthew Paris, for the Rolls series (1858). As an editor he shows a rare combination of profound scholarship and temperate caution. His original writings are

found in the pages of the *Archæologia* and *Collectanea Topographica*.

Madder (*Rubia*), a genus of plants of the natural order Rubiaceæ. The species are found in the tropical and warmer temperate parts of both the Old and New Worlds, and from early times till recently were important for the colouring matter of their roots, especially for dyeing Turkey-red. The most important is the Common Madder or Dyer's Madder (*R. tinctorum*), a native probably of the south of Europe as well as of Asia. It is a perennial, with weak stems and whorls of four to six elliptic or lanceolate glossy leaves, the stem and leaves rough with sharp prickles, small greenish-yellow flowers, and black fruit. Munjeet, or Indian Madder (*R. munjista* or *cordifolia*), ranks next to it in importance. *R. peregrina*, found in the south-west of England, and called Wild Madder, is very similar to *R. tinctorum*. Since the discovery of artificial Alizarin (q.v.) the commercial importance of madder has rapidly decreased (see DYEING, Vol. IV, p. 138). In 1875, 126,152 cwt. were imported into Britain (value £410,993); but in 1888 (with munjeet, garancine) only 14,204 cwt. (value £18,067).

Madeira, the largest of a small group of islands in the North Atlantic Ocean, off the north-west coast of Africa, from the nearest point of which it is 390 miles distant, in 32° 40' N. lat., 17° W. long. It lies 1164 miles SW. of the Lizard, and 535 miles SW. of Lisbon, and is within four days' sail of Plymouth, and six of Liverpool. The other islands of the group are Porto Santo, 23 miles to the NE., with a population of less than 2000; here Columbus lived for a time before he touched at Funchal. The Desertas, 11 miles SE., are three uninhabited islands consisting of Deserta Grande, Bugio, and Ilheo Chão. Madeira (Portuguese, 'timber,' the island having once been well wooded) was uninhabited when discovered in the 14th century, and was first settled in 1419. It is 38 miles long, by 12 to 15 wide, and along with the other islands of the group is treated as an integral province of Portugal, entitled to send representatives to the Cortes at Lisbon. It was occupied by British troops in 1801 for a few months, and again from 1807 to 1814. Pop. (1881) 132,223; estimated (1898) 140,000. It is traversed by a mountain-chain running east and west, with deep ravines between the lateral ridges thrown off, the most notable of which is the 'Grand Central,' with a depth of more than 2000 feet. The islands are of volcanic origin, and are the summits of lofty mountains, rising in Pico Ruivo to 6659 feet, in Torres Peaks to 6000, Pico Anfiado to 5895, and in many others to 4000 and 5000 feet. Slight earthquakes occasionally occur. In the south the brooks are dry in summer, and the country is treeless and arid; the north side is more luxuriant and fertile, with wider areas of cultivated ground; in the north-west are undulating grassy plains. The coasts are steep and precipitous, the only harbour being that of Funchal (q.v.) on the south coast, which is little better than an open roadstead where passengers are landed in boats. The Loo rock has, however, been joined to the mainland to form a breakwater, and a pier was undertaken in 1889.

The clouds, which are attracted by the mountains, yield plenty of moisture, and the climate is remarkable for its constancy, though probably too relaxing for those in perfect health, and accustomed to a temperate climate. The thermometer at Funchal shows a mean temperature of 61° F. At the coldest season the thermometer occasionally registers a minimum of 50° F. In the hottest days of summer it seldom rises above 80°, while 90° is exceptional. The prevailing wind during nine

months of the year is north east. The average rainfall is 29 inches, and the average number of days on which rain falls in heavy showers is 70, but there are few really wet days. The temperate and constant warmth of its climate has made it a favourite resort for invalids affected by pulmonary disease. The only land reptile is the lizard, and Madeira has no indigenous mammalia, though the ordinary domestic animals, together with rabbits, rats, and mice, have been introduced by the Portuguese. The fruits and grains of Europe are cultivated on the lower levels; the products include wheat, barley, Indian corn, the potato, oranges, lemons, guavas, mangos, figs, and bananas. Travellers praise the golden splendour of the wide expanses of gorse and broom in blossom, and of the marvellous masses of colour, pink, mauve, and brick-dust red of the flora of the island. There are between 300 and 400 genera of wild flowering plants, and 717 species; more than 40 species of ferns, and 100 of moss.

Wine is the chief export, several kinds being produced in the island. That known in Europe as Madeira, a wine of strong body and fine bouquet, is made of a mixture of black and white grapes. The vines were nearly exterminated in 1852 and succeeding years by oidium, but were soon replanted; and oidium and the phylloxera have since been kept in check by sulphur, so that only one bad vintage has been recorded in twenty-five years. Sugar-canes brought from Demetara and the Canary Islands are flourishing.

The inhabitants are of mixed Portuguese, Moorish, and Negro descent; they are of vigorous frame, lively, and industrious, economical and simple in their habits. In 1888 there were 4000 emigrants chiefly to the Brazils. A great drawback to visitors is the absence of roads; the only six miles of macadamised roadway being that between Funchal and Camara do Lobos, a fishing-village of about 6000 inhabitants. Loads are carried on the head by natives, and hammocks and sledges drawn by bullocks are used for the tracks, while small sledges assist travellers down the mountains sometimes. The government is non-progressive, and Roman Catholicism is predominant. At Funchal there is the governor's palace, town-hall, opera-house, cathedral, English church, and Presbyterian church in connection with the Free Church of Scotland. The Lyceo at Funchal has 7 professors paid by government.

Articles of native produce, such as meat, poultry, and eggs, are cheap; but all imported articles, owing to the high import duty, are dear. There is a weekly mail and cable connection from Funchal with Lisbon and Brazil. The imports have an annual value of about £200,000. The value of the exports, mainly wine, reaches some years £185,000. The leading imports consist of coal, dry-goods, maize, wheat, and petroleum. The export of fruit and vegetables is on the increase; and as irrigation has been introduced with great advantage, Madeira promises to become more and more the market-garden of London. The trade is chiefly with Great Britain.

See works by White (2d ed. 1860), Graham (1869), Piazza Smyth (1882), Miss Taylor (1882), Yate Johnson (1883), Brown (1890), C. A. Gordon (1894), and articles in *Lubbock's Magazine* (vol. xii. 1875) and *Blackwood's* (vol. cxliii. 1888).

Madeira, the great affluent of the Amazons, has its origin in the confluence of the Mamore (q.v.) and Cunaporé (q.v.), at about 12° S. lat., the Beni (q.v.) joining 110 miles lower down. The river then flows north east to the Amazons, its drainage basin embracing some 425,000 sq. m. From its mouth to its first falls the distance is 578 miles; above this point navigation is broken

by a series of nineteen falls, rapids, and cataracts for a distance of 230 miles, and it has been proposed to construct a railway to pass these, and so provide an outlet by the Amazons for the products of Bolivia. See Keller-Leuzinger, *Com Amazonas und Madaina* (1873; Eng. trans. 1874).

Mādhava is an appellation of the Hindu god Vishnu (q.v.). See **ŚĀNDĪA**.

Madhava Achārya ('Madhava the *Acharya*'—i.e. 'spiritual teacher'), a Hindu writer of the 14th century, famed for his numerous and important works relating to the Vedic, philosophical, legal, and grammatical writings of the ancient Hindus.

Madison, (1) the capital of Wisconsin, founded in 1836, is situated on an isthmus between Lakes Mendota and Monona, 82 miles W. of Milwaukee, at the junction of several railways. It contains the state capitol, university (founded in 1849, and open to both sexes), and lunatic asylum, and has manufactures of flour, farming implements, machinery, &c. Pop. (1885) 12,064.—(2) Capital of Jefferson county, Indiana, on the Ohio River, 86 miles by rail SSE of Indianapolis. It has flour-mills, boiler and engine works, steamboat-yards, and manufactories of furniture and leather, besides large pork-packing establishments. Pop. (1880) 8945; (1890) 8923.

Madison, JAMES, fourth president of the United States, was born at Port Conway, Virginia, March 16, 1751, graduated at Princeton in 1772, and studied law. In 1776 he was a member of the Virginia Convention, and took a useful part in drawing up the state constitution. His life from this time was devoted to politics, and he became one of the most eminent, accomplished, and respected of American statesmen. In 1780 he was elected to the Continental congress, and in 1784 to the legislature of Virginia, in which he was chiefly instrumental in securing the recognition of the right to religious liberty. But at this period anarchy was threatening the young republic, which hitherto had been but a loose confederation of states. Congress was a deliberative body merely; its members represented states only, and its powers were practically confined to that of giving advice. Madison was active in bringing about the Convention of 1787, which framed the Federal constitution. There he acted with Jay and Hamilton, and with them wrote the *Federalist*. He was the chief author of the 'Virginia plan,' which even went some way towards disregarding state rights. He also suggested the important compromise under which, whether in apportioning taxation or representation, slaves were to be regarded as population and not chattels, but five were reckoned as three persons—the so-called 'three-fifths rule,' which secured the adoption of the constitution by South Carolina and the other slave-holding states. A month's discussion and all Madison's arguments were necessary before the Virginia Convention was brought to ratify the constitution, and that only by 89 votes to 79. Madison was elected to the first national congress. He had done as much as any man, perhaps, to secure the adoption of the constitution, but he now showed himself anxious to limit the powers of the central government to the strict letter of their commission therein contained. He opposed the financial policy of Hamilton, and became a leader of the Republican or Jeffersonian party. In 1801, Jefferson having been elected president, Madison was made secretary of state, which post he held during the eight years of Jefferson's administration. In 1809 he was elected president. The European wars of that period, with their blockades and orders in council, were destructive of American commerce, and ultimately brought on a war with England, which was declared in 1812, and

continued for two years, at an enormous cost of life and treasure. In 1817, at the close of his second term, Madison retired to his seat at Montpelier, Virginia, where he died, June 28, 1836. Modest and reserved, courteous and kindly, he is a pleasant as well as an important figure in American history. He was not a brilliant man, but he was a statesman of eminent ability and purity of character. See the *Lives* by Rives (Boston, 3 vols. 1859-68) and Gay ('American Statesmen' series, 1884).

Madison University. See **HAMILTON**, U.S.

Madness. See **INSANITY**.

Madoc, son of Owen Gwynedd, a Welsh prince, is believed by his countrymen to have discovered America about 300 years before Columbus. Compelled, it is said, by civil strife, to abandon his native land, he sailed westward in 1170 with a small fleet, and, after a voyage of several weeks, reached a country whose productions and inhabitants were quite unlike those of Europe. Here he lived for a long time; then, returning to Wales, he gave an account of the new land that he had discovered, equipped another fleet, set sail again, and was never more heard of. The story will be found in Lloyd and Powell's *History of Cambria* (1584); but see the essay by Thomas Stephens written in 1858 for the *Eisteddfod*, and published in 1893. There is no foundation for this Welsh tradition; even if it were, the Northmen have a prior claim to the discovery of America, for it is beyond doubt that Greenland and the New England States were visited by them at a much earlier period. Catlin in his *Lectures on the North American Indians* (1841) hazardingly describes the Tuscaroras as a mixed race descended from Madoc's Welshmen and the aborigines. Southey has chosen the story of Madoc as the subject of one of his so-called epics.

Madonna, an Italian word meaning 'My Lady,' used as the generic title for works of art, generally paintings, representing the Virgin, or the Virgin with the Infant Christ. Legend credits St Luke with having painted the first Madonna, a portrait put on the canvas from life, and with having carved the image of the Virgin in the Santa Casa at Loreto. After the Council of Ephesus (431), images of the Virgin with the Saviour in her arms became the recognised symbols of the orthodox faith. But the iconoclastic fury fomented by Leo III., the Isaurian, entailed the destruction of many of those early Madonnas. The oldest representations of the Virgin that survive are those which have been found in the catacombs, accompanying the tombs of the early Christians. Cimabue was the first to put natural life into the dead and angular designs of the Byzantine artists, and with him began that wonderfully productive and brilliant period of Italian art the all dominant theme of which was the Madonna, that culminated in the glorious works of Raphael—the Sistine Madonna, the Madonna della Sedia, &c. These Italian artists handed on the cult to the German masters, who not only executed more realistic, more human pictures of the Virgin, but carved her effigy in wood. Amongst so many artists it is not surprising to find the subject treated in diverse styles and manners. To quote Mrs Jamison (*Legends of the Madonna*, new ed. 1890): 'Thus we have the stern, awful quietude of the old mosaic; the hard lifelessness of the degenerate Greek; the pensive sentiment of the Siena and the stately elegance of the Florentine Madonnas; the intellectual Milanese, with their large foreheads and thoughtful eyes; the tender, refined mysticism of the Umbrian; the sumptuous loveliness of the Venetian; the quaint characteristic of the early German, so stamped with their nationality; . . . the intense lifelike feeling of the Spanish; the prosaic, portrait-like nature of the Flemish schools; and so on.'

The title Madonna is not used with rigid consistency; it is also applied to representations of the Annunciation, Nativity, Adoration of the Magi, Flight into Egypt, Holy Family, and all the several scenes and incidents in which the Virgin Mary personally figures. She is often represented too in certain specific characters with appropriate epithets, as La Vergine Gloriosa (with Jesus), Our Lady of Sorrow, Queen of Heaven, &c. Entire series exist depicting the events of her life, painted by painters like Giotto, Orcagna, Albert Dürer, and Luini. Two common series are the Seven Joys and the Seven Sorrows of the Virgin.

Besides Mrs Jameson's book, see works by Rohault de Fleury (1878), A. Schultz (1879), Erkl (1883), Von Schreibershofen (1886), for the middle ages; 1879); Ehl, for the older German schools (1884); and Laell, for the catacomb pictures (1890).

Madras City (called by the natives *Chennaimattur*) is situated on the Coromandel Coast in 13° 4' N. lat. and 80° 17' E. long., and is the capital of the presidency of the same name. The town extends along the shore for a distance of 9 miles, and covers an area of about 27 sq. m. Originally it consisted of a number of separate villages, which are now united into a single municipality, administered by a president, two vice-presidents, and thirty-two non-official commissioners, of whom twenty-four are elected by the ratepayers and eight nominated by government. The roadstead, in which till quite recently all ships had to lie, is very much exposed, and on the approach of a cyclone all vessels put out to sea. A pier was erected in 1859-62. A harbour begun in 1876 was seriously damaged in 1881, and the construction of the harbour was being carried on in 1890, but it is questionable whether it will ever be safe for ships to remain in it during a heavy storm. It already, however, greatly facilitates the landing of cargo during rough weather, and passengers have no longer to cross the surf in going to or coming from steamers. A marked feature of this part of the coast is the heavy surf which rolls in, even in comparatively calm weather. In ordinary weather the surf breaks about 300 feet from the shore, and the wave is of no great height; but in stormy weather there are two lines of surf, the outer one being some 1000 feet from the shore with a wave of 12 to 14 feet high. The ordinary surf can be crossed with safety by the native *mussah* boats, which are formed of planks sewn together with string, but no boat can live through the surf in a cyclone. The port is liable to be visited by these storms at two seasons—towards the end of May and beginning of June, when the south-west monsoon sets in, and in October, November, and the early part of December, during the prevalence of the north-east monsoon. Cyclones are rare at other times. The climate of Madras may be described as hot and moderately dry. The annual rainfall averages 49 inches, falling on ninety-five days, but during the seventy-four years ending with 1889 it varied from 88½ inches in 1827 to 18½ inches in 1822. The mean temperature for the year is 82° F., varying from 76° in December and January to 88° in June. During the hot months the temperature frequently rises above 100°, but the *monsoinum* in no month exceeds 99°. The mean annual range is 18°. The highest temperature recorded in the twenty-seven years ending with 1889 was 112.9 and the lowest 57.6°. The heat of the hot season is greatly modified by a sea-breeze, which often sets in soon after noon and blows till sunset. On the whole the climate is a healthy one.

On the shore, midway between the north and south extremities of the town, is Fort St George, the original settlement. This fort (built 1730) still contains the council chamber, a number

of government offices, and barracks for the European troops. North of the fort lies Black Town, which contains most of the business offices and a crowded native population; south of it lies Triplicane, the chief Mohammedan centre. Inland and to the extreme south lie the houses chiefly occupied by Europeans, most of which stand in large compounds or parks, surrounded by trees. Though Madras cannot compete with either Calcutta or Bombay in the magnificence of its public buildings, it contains some that are worthy of note. Amongst these may be mentioned Government House, the Chepauk Palace, the Senate House, St Andrew's Kirk, St George's Cathedral (containing a monument by Chantrey to Bishop Heber), the Madras Club, the post and telegraph office, and the new High Court buildings. Many of the buildings are rendered specially striking by the free use of polished *chamun* made from shell lime. The Madras University, founded in 1857, is simply an examining body, the teaching being done by affiliated colleges throughout the presidency. Some idea of the work done by the university may be gathered from the fact that in 1888-89 there were 7433 candidates for matriculation, 576 for the degree of B.A., 163 for the degree of B.L., and smaller numbers for the other degrees. In addition to colleges for the study of arts, medicine, and engineering, there are, in or near the city, a School of Art, a College of Agriculture, a branch of the Royal Asiatic Society, and a large museum, containing, amongst other things, very valuable collections of Indian coins and of sculptured marbles from the Buddhist 'topes' at Anuravati. Madras is the seat of the government and of the supreme court. Pop. (1881) 465,848, of whom 3205 were Europeans, 12,659 Eurasians, and 50,298 Mohammedans, the rest being Hindus by faith; (1891) 452,518. The chief articles of export are coffee, tea, cotton, grain, hides, indigo, oil seeds, dyestuffs, sugar, and horns. The average value of exports and imports for ten years previous to 1895 was about £4,000,000 and £11,000,000 respectively. For the railway connection, see under the presidency below. The Buckingham Canal gives a waterway to the north and south parallel to the coast.

Madras Presidency, one of the administrative divisions of India, occupies the southern part of the peninsula; it is also known as the Presidency of Fort St George. It extends from lat. 20° 18' on the eastern coast and lat. 14° on the west coast to Cape Comorin in lat. 8° 4'. The total area, excluding native states, is 139,000 sq. m.; pop. (1881) 30,868,504; (1891) 35,630,440. (The native states have an area of 9600 sq. m., and a population of 3,700,622.) Of these some 39 millions are Hindus, about 2 millions Mohammedans, and 800,000 Christians. For revenue purposes the presidency is divided into twenty-two districts. The chief government officer in each district is the collector, who controls all departments except the judicial. The principal mountains belong to the two chains of the Eastern and Western Ghats. The former have an average height of 1500 feet, but rise in parts to 3000 or 4000 feet; the latter have a considerably greater average height, with a number of peaks rising from 5000 to 8000 feet, and a few even higher. A considerable part of the presidency forms a tableland, which includes the native states of Mysore and the Deccan, rising to a height of from 1000 to 3000 feet. A very notable geographical feature is the Palghat Gap in the Western Ghats, 25 miles wide, and only 1000 feet above sea-level. Through it passed the old trade route between the west and east coast, now superseded by a railway, and through it the south-west monsoon blows strongly, bringing rain to a considerable

area lying east of it. The Nilgiri Hills, on which at Ootacamund is the summer seat of the government, may be looked on as the junction of the Eastern and Western Ghats. There are also several important outlying spurs, of which the Shevaroyis in Salem, the Anamalais in Coimbatore, and the Palnis in Madura are the most noteworthy. The chief rivers are the Godavari, the Kistna, and the Kaveri, all rising in the Western Ghats, and crossing the peninsula in a south-easterly direction to the Bay of Bengal. Very extensive irrigation-works have been carried out in connection with each of these rivers, while minor irrigation-works are to be found in almost all parts of the presidency. Railway communication is being rapidly extended throughout the country. The Madras Railway (5 ft. 6 in. gauge), with its terminus at Madras, crosses the country in two lines. The one passes in a south-westerly direction to Calicut on the Malabar coast, with branches to Bangalore, where it connects with the Mysore Railway, and to Mettappallem, the station for the Nilgiris. The other crosses in a north-westerly direction to Raichor, where it connects with the Great Indian Peninsular Railway. At Guntakal it makes connection with the extensive system of the South Mahratta Railway. The South Indian Railway (metre gauge) runs south from Madras to Timmavelli, with branches to Pondicherry, Negapatam, and Tuticorin; a line from Trichinopoly connects it with the Madras Railway at Erode, and another branch from Chengalpat connects it with the same railway at Arcotum. There are good roads in most parts of the presidency.

The climate differs greatly in different parts. In the Carnatic the dry season lasts from the middle of December till the end of June, there being often three or four months without any rain. From June to October there are heavy showers, and from October to the middle of December the north-east monsoon brings copious rain. Over a great part of the east coast strip the annual rainfall exceeds 40 inches; but in some parts inland it does not exceed 20 inches, and in many parts it falls below 30 inches. The mean annual temperature is about 82°, and in many stations a maximum temperature of upwards of 110° is not uncommon. On the Malabar coast the rainfall is much heavier, and comes with the south-west monsoon. The moisture-laden winds, being driven upwards by the lofty mountains, cool as they ascend, and pour down their surplus moisture on the strip of land between the hills and the sea. Thus, the fall from June to October is 119 inches at Mangalore, and 132 inches at Honawar. The annual rainfall at Mangalore is 131 inches, and at Cochin 115 inches; at the latter place 227 inches fell in 1882. This abundant rainfall leads to a most luxuriant vegetation in Travancore and on the west coast. The mean temperature varies from 79° to 80°, and there are no great extremes. The climate of the hill-stations is not unlike that of England at its best. Frosts are not unknown, but are slight, and in summer the temperature never rises very high. The climate of the Nilgiris has been described as 'that of the English spring and summer without Atlantic storms or the bitter east winds of March.' Save when the monsoon is at its height, it would be difficult to imagine a finer climate. Rice is the chief crop grown throughout the presidency, but several other cereals are largely cultivated. Pulse, groundnut and other oil-seeds, indigo, and sugarcane are of great importance in certain parts. Cotton is grown over a wide area in the drier parts, and tobacco of excellent quality is produced in large quantities on islands in the Godavari, and in parts of the Coimbatore and Madura districts. Trichinopoly cigars and cheroots are increasingly

exported. On the hills tea, coffee, and cinchona are successfully cultivated over wide areas. The manufacturing industry is represented by cotton, sugar, gunny bags, paper, ice, and tiles. Madras is not rich in minerals; but gold is found in many parts, and, though the most productive mines at present worked lie in Mysore, there is good reason to hope for equally favourable results from mines opened in other areas of the Darwar Rocks, which are apparently the only auriferous strata in the presidency. Iron of excellent quality abounds, and is worked by the natives; but the want of fuel prevents any large development of the iron industry. Diamonds have been largely found, chiefly in the Karnul district. The forests are now carefully protected by the state, and are of great value, especially the teak forests.

The first English settlement was made at Masulipatam in 1611. In 1616 factories were established on the west coast at Calicut and Cranganore. In 1619 a factory was opened alongside of the Dutch one at Pulicat, but this was soon withdrawn. In 1628 the Masulipatam factory was transferred to Arnagaon, 40 miles north of Pulicat, and this was the first place fortified by the English in India. In 1639 a settlement was obtained at Madras. Christian missions have made more progress in Madras than in any other part of India, there being 228 Christians in every 10,000 inhabitants; Lower Burma follows closely with 225, while Bombay has only 62 and Bengal 18.

Madras System. See BELL (ANDREW).

Madrepore. See CORAL.

Madrid. the capital of Spain and seat of the Spanish government, is situated in the department of the same name, in the ancient province of New Castile, on the left bank of the Manzanares, in 40° 24' N. lat. and 3° 25' W. long., 880 miles by rail from Paris. It is built on a treeless, ill-watered plateau, 2060 feet above the sea-level, and was created capital by the arbitrary will of a sovereign. The Manzanares is merely a mountain-torrent falling into the Jarama, a tributary of the Tagus, useless for communication, and not even to be depended upon to supply the city with water, which is brought from the Guadarrama Mountains by an aqueduct 42 miles in length. The sole recommendation of Madrid as capital is its central position in the Peninsula; it is nearly equidistant from the Atlantic and Mediterranean coasts and from the Pyrenean frontier. Swept, during the winter months, by the icy winds from the snow-capped mountains on the north, and exposed in summer to a burning sun, it has a climate which, though dry and bright, shows extreme variations of temperature (104° to 14°). The average of the eight warmer months (March to October) is 66° F., and that of the four remaining ones 44°, but the difference at the same time between sun and shade is sometimes as great as 20°. In spite of a death-rate of over 34 per thousand, caused by its treacherous climate and the insanitary habits of its citizens, the increase of Madrid has of late years been rapid. At the beginning of the 19th century the population was about 160,000; in 1860 it was 298,000; in 1870, 332,000, and in 1895, 500,000; less than 40 per cent., however, of the inhabitants are natives of the city. Madrid is nearly circular, unfortified, and about 10 miles in circumference.

Through the Latin and Arabic chroniclers Madrid can trace its existence as far back as the 10th century, when it was known as *Madina Magerit*, a fortified post of some importance on the frontier of the Moorish Kingdom of Toledo. First retaken by the Christians under Ramiro II. of Castile (939), it was not finally conquered till the reign of

Alfonso VI. (1085). A list of its inhabitants, Castilian and Mozarab, appears in a charter of Toledo granted by Alfonso VIII. in 1117. After this time the mention of it in documents is frequent. The part first inhabited was the high ground where the royal palace now stands on the west of the city: here was the stronghold that first gave the place celebrity. As the Christian frontier was pushed farther southward, Madrid would probably have again sunk into obscurity had it not been a favourite place of meeting for expeditions against the Moors, and temporary residence of the kings, who were attracted by the game sheltered in the extensive forests, long since destroyed, to the great detriment of the climate. The city received its first charter in 1202, and the Cortes were first held in it by Ferdinand VI. (1309), and subsequently by Alfonso XI. and Henry III., the former of whom altered the constitution of the city, giving it twelve *regidores* and two *alcaldes* in place of the *Señor de Madrid*, who had formerly been elected by nobles and commons. John II. and Henry IV. granted additional privileges to the city. Isabel the Catholic acquired the city after a sharp struggle with the partisans of her rival Doña Juana, and it now became a place of some importance owing to the more frequent presence of the court. After the death of the Catholic kings, the regent, Cardinal Cisneros, ruled Spain from Madrid, and, though the city embraced the popular cause in the war of the Comuneros, it received such privileges from the Emperor Charles V. that its population rose rapidly from 3000 to 6000 households; during this reign it furnished a prison for Francis I., king of France. When in 1561 Madrid was declared capital of Spain by Philip II. it contained about 30,000 inhabitants. With the court came the great nobles, who built palaces, and innumerable friars, who established convents; nevertheless till the middle of the 17th century the city presented a mean appearance, and most of the houses were only one story high, thus avoiding the obligation of lodging the numerous retinue of the kings. Philip IV. made some improvements, especially the laying out of the park of the Buen Retiro, and in his time Madrid, though still unpaved, filthy, and roamed over at will by the privileged pigs of St Anthony, was the seat of one of the most brilliant courts of Europe. The greatest benefactor of the city was King Charles III., many of whose splendid works still exist. Madrid took an active part in the revolution that wrested the power from Godoy, the Prince of the Peace, and during the domination of Napoleon (2d May 1808) made a gallant attempt to shake off the foreign yoke. Though taken by the allied force under the command of the Duke of Wellington in 1812, Madrid was not finally rid of the French till 1813. The next year marked the return of the Bourbon king. Although the scene of several of the revolutions that form so large a part of Spanish history during the 19th century, Madrid, aided by the suppression (1836) of the convents, the introduction of railways (1850), and an abundant supply of good water (1858), has been continually and rapidly advancing in importance and prosperity.

The general aspect of the city is clean and gay, whilst the older parts, the Calle de Toledo, Plaza Mayor, and district of Lavapies, are picturesque; no trace of the medieval city now remains. It is administered by a military and a civil governor, aided by the mayors of the ten districts into which it is divided. The police is good, and Madrid is as safe as any European capital, well lighted, but indifferently paved (wood pavements have lately been laid down in several streets). The new streets are generally fine, broad, and planted with trees; the houses well built, lofty, stuccoed and painted, and inhabited by several families living in flats, guarded

at night by watchmen (*serenos*), to whom the key of the street door is entrusted. A great feature is the magnificent open spaces, chief of which is the Prado, running north and south through the eastern part of the city, and, with its continuations, three miles long; it contains four handsome fountains with groups of statuary, a fine obelisk to commemorate the gallant struggle of the citizens with the French (May 2, 1808), monuments to Columbus, the Marques del Duero, and Isabel the Catholic. The picture-gallery, founded by Charles III., and situated in the Prado, is one of the finest in Europe, and contains the principal works of Velasquez and Murillo, besides many of the masterpieces of Raphael, Tintoretto, Rubens, Teniers, and Van Dyck. Two other parks are the Buen Retiro, the fashionable promenade on the east of the city, and the Casa de Campo on the west. Midway between its extremities the Prado is crossed at right angles by the Calle de Alcalá, the finest street in the city, about a mile in length, and leading from outside the fine triumphal arch rebuilt by Charles III. to the Puerta del Sol, a handsome though not very large square, with broad pavements, and a fountain in the centre. This square is the heart of Madrid; here converge the principal tramway lines which have so greatly aided the extension of the city, and in it and the streets branching off from it are situated the principal shops and places of business. The finest square is the Plaza Mayor, formerly the scene of bull-fights and *autos da fe*, and said to have held 50,000 spectators; it contains a gigantic equestrian statue of Philip III., its founder, and was formerly the centre of Madrid, but is now somewhat decayed as the city has moved farther eastward. On the west of the city is situated the royal palace; commenced in 1738 to replace the ancient Alcazar, which had been burned down, it was finished in 1764 at a cost of about £3,000,000. It is a fine stone building in the Tuscan style, forming a square of 479 feet, and enclosing a court of 140 feet; its architect was the Italian Sacchetti. Dependencies of the palace are the royal armoury, containing the finest collection in the world, and the royal stables, remarkable for their extent. Other fine buildings are the palace of justice, formerly a convent; the houses of parliament, Palacio de los Consejos; Buena Vista Palace, now the ministry of war; the new national bank; and the town hall. Besides a flourishing university, founded by Cardinal Cisneros, and two high schools, Madrid contains 118 municipal and 21 pauper schools, with an aggregate of 11,000 pupils. There are many charitable institutions, and the municipality maintains dispensaries in each of the ten districts; but hospital accommodation is deficient, and beggars abound in spite of the law. Madrid is well provided with newspapers (about six leading dailies and several periodical reviews) and public libraries, the chief being the National Library, with more than half a million volumes, and the library of the university; those of the palace and of the Academy of History contain many treasures. Amongst the many learned societies the principal are the Academies of History and the Spanish Language; the Ateneo is a flourishing literary club with a good collection of books. The opera-house is one of the finest in the world; all the theatres must by law be lit by electricity. The bull-ring, situated outside the gates on the east, is a solid structure seating 11,000, and owned by the provincial council. The churches are mostly small and insignificant; the handsomest is the recently-rebuilt church of San Francisco. The plain church of San Isidro, patron of Madrid, serves as cathedral. The old church of Atocha, containing a much-venerated image, the tombs of several celebrated

men, and many banners that recalled the great days of Spain, has recently been pulled down. Madrid is rather a consuming than a producing centre; such manufactures as do exist contribute only in a small degree to supply the needs of the city. Ironfoundry, the manufacture of furniture, carriages, and fancy articles are carried on on a small scale. The manufacture of tobacco, the monopoly of which is farmed by the government to a company, employs many hands, chiefly women. The publishing trade is important, and books are well printed and cheap. The old tapestry-factory still turns out beautiful work, and the potteries at Moncloa are now producing good imitations of many of the artistic kinds of earthenware for which Spain was formerly celebrated. The exchange and money-market, largely carried on by foreigners, is the most important in Spain.

See Ayala y Sastre, *Madrid, Biblioteca de la Provincia* (1889); Mesonero Romanos, *El Antiquo Madrid* (1881). For Madrid (Province), see SPAIN.

Madrigal, a word of uncertain etymology, denotes a short lyrical poem, generally on the subject of love, and characterised by some epigrammatic terseness or quaintness. It was written, as a rule, in iambic metre, contained not less than six or more than thirteen lines, and ran chiefly upon three rhymes. Among the Italians the best writers of madrigals are Petrarch and Tasso; among the French, Montreuil and Monerif; among the Germans, Hagedorn, Voss, Goethe, and A. W. Schlegel; and among the English, Lodge, Withers, Carew, and Suckling.—The name is also applied to the music for a simple song sung in a rich artistic style, but without musical accompaniment. The original composers wrote for three, four, or more voices; but madrigals are now usually sung by a small but well-trained choir. These compositions originated with the Flemings, and before the middle of the 15th century. From them and by them it was carried to Rome and Venice, and to England, where a famous school of madrigal composers flourished from about 1530 to about 1630. The chief composers of the English school were Bird, Weelkes, Kirkby, Wilby, Morley, Dowland, Bonet, Este, Bateson, and Orlando Gibbons. Madrigal singing ceased to be popular in the 18th century; its place is now taken by glee-singing (see GLEE). The Madrigal Society of London, founded in 1741 by John Lumyns, claims to be the oldest musical association in Europe. See Sherman, *Madrigals and Catches* (New York, 1887).

Madura, a maritime district of India, in the south of the Presidency of Madras, is bounded on the E. by the Gulf of Manaar, which separates Hindustan from Ceylon; it has an area of 8808 sq. m., and a pop. of 2,608,404. Chief town, Madura, third largest in the presidency; pop. (1881) 73,807; (1891) 87,428. For nearly 2300 years Madura was the political and religious capital of the southernmost part of India. Its Pandyan kings are mentioned by the ancient Greek geographers. In the 17th century the Nayak rulers, chiefly Tirumala (1623-59), built here a magnificent pagoda to Sunderswara (Siva), with a hall having one thousand (997) pillars, a fine palace, now ruined, a summer palace for the god, and a great tank. The Jesuits have been active in Madura since the time of Tirumala; there were 67,554 Roman Catholics in the district in 1881.

Madura, an island of the Dutch East Indies, separated by a narrow strait from the north-east of Java, with an area of 1764 sq. m. It is mostly barren, but possesses numerous forests and salt marshes. Along with some eighty smaller islands, lying mostly to the east, it forms a Dutch residency; area 2040 sq. m.; population 1,500,000

The people, of Malay descent, resemble the Javanese, but are stronger, more enduring, and more enterprising; they make the best native soldiers in the Dutch colonial army.

Madvig, JOHAN NICOLAI, Danish classical scholar, was born at Svaneke, in Bornholm, on 7th August 1804, educated at Frederiksborg and Copenhagen, began to teach at the university in 1826, and in 1829 was appointed to the chair of Latin Language and Literature, and made inspector of higher schools. He took a keen interest also in politics, was one of the chief speakers of the national Liberal party, sat in parliament, held the portfolio of religion and education from 1848 to 1851, and after 1855 was repeatedly elected president of the Danish parliament. He died blind on 13th December 1886. For more than half a century Madvig enjoyed the highest reputation, not in Denmark only, but throughout Europe, as a shrewd, clever critic of the Latin and Greek prose-writers. It was in criticising and emending the text of Cicero and Livy that he won his greatest laurels, his *Emendationes in Ciceronis Libros Philo-sophicos* (1828), editions of *Cicero's De Finibus* (1839; 3d ed., greatly improved, 1876), *Cato Major et Lelius* (1835; 2d ed. 1869), *Emendationes Liviana* (1860; 2d ed. 1876), and the edition of *Livy* (4 vols. 1861-66) being all productions of first-rate scholarship. He provided for students very valuable information on Cicero's works in *Opuscula Academica* (2 vols. 1834-42; 2d ed. 1887); worked out a systematic account of his critical principles in *Adversaria Critica* (3 vols. 1871-84); published in 1841 his well-known *Latin Grammar* (7th ed. 1881), and in 1846 his still better known *Greek Syntax* (Eng. trans. 1853), both excellent works, but now being superseded by the results of newer philological study. The last books from Madvig's pen were a dissertation on the *Constitution and Administration of the Roman State* (2 vols. 1881-82), intended in some sort as supplementary and corrective to Mommsen's great history, and an *Autobiography* (1887).

Maander (now *Bajal Meander*), the ancient name of a river of Asia Minor, rising near Celene, in Phrygia, and flowing 240 miles west-south-westward to the Egean at Miletus. Its windings, proverbial since Cicero's day, are after all nothing remarkable.

Mecenas, C. CILNIUS, a Roman statesman of Etruscan origin, whose name has become a synonym for a patron of letters. He first appears in history in 40 B.C. engaged in arranging a marriage between Octavian and Scribonia. Later we find him negotiating the peace of Brundisium, and acting with vigour in the city during the campaign of Actium. When Octavian assumed the supremacy and the title of Augustus, Mecenas took a chief place in his counsels. The nature and extent of his official power are not very precisely understood, but they were undoubtedly great, though the influence and authority he enjoyed are to be estimated rather from his intimacy with the emperor than his mere position as a public servant. During his later years the friendship was interrupted from reasons that cannot now be exactly ascertained, but mutual esteem survived and no open rupture took place. Mecenas was a thoroughly sincere imperialist. He had a belief in the value of an established government; and when he found that he no longer retained the confidence of his sovereign he did not lapse into a conspirator; but, as a modern minister might do, retired into the obscurity of private life. He had ever been given to luxury and sensual delights, but his complex nature craved the solace also of higher pleasures. He now gave all his time to literature and the society of literary men. He was immensely

rich, and kept an open table for men of parts at his fine house on the Esquiline Hill; above them all he loved the genial Horace. He died in the year S. B. C., leaving the emperor his wealth.

Maclar. See MALAR.

Maelidm. See MAILDUN.

Maelström ('grinding stream'), or **MOSKENSTROM**, a famous whirlpool, or more correctly current, between Moskenis and Mosken, two of the Lofoden Isles (q.v.). The strait is habitually navigated by vessels at high tide and low tide, though in one place the water is always rough and churned into angry foam. When the wind blows directly against the current it becomes extremely dangerous, especially with spring-tides or during a north-west wind. The stories of ships, whales, &c. being swallowed up in the vortex are simply fables; at the same time, a ship once fairly under the influence of the current, would probably founder or be dashed upon the rocks, and whales have often been found stranded on the Flagstadt coast from the same cause. The current takes twelve hours to make a circular revolution. Edgar Allen Poe's imaginative description of the horrors of being sucked down by the Maelstrom is well known. A like dangerous current is the Saltstrom, at the entrance of the Salten Fjord, where a vast mass of water is poured through a narrow opening at a terrific rate. Yet steamboats pass through the Saltstrom, though only at high or low tide.

Maenads. See DIONYSUS.

Maeshowe, a chambered mound in the Mainland of Orkney, 9 miles WNW. of Kirkwall and 1 mile E. of the great stone circle of Stennis. A grassy truncated cone, 36 feet high and 92 feet in diameter, it is surrounded, at a distance of 90 feet from its base, by a trench 40 feet wide, and still in places 8 feet deep. On the west side is a passage, 54 feet long, $2\frac{1}{2}$ to $3\frac{1}{2}$ feet wide, and $3\frac{1}{2}$ to $4\frac{1}{2}$ feet high, with (about midway) a unique doorway. This passage leads to a central chamber, measuring $15\frac{1}{2}$ by 14 feet; converging to a vaulted roof, originally 20 feet high; and built, like the passage,

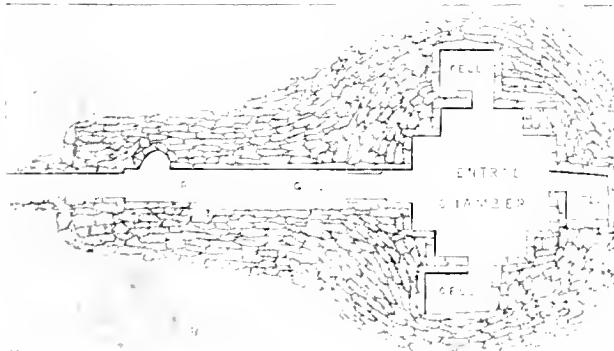

Maeshowe, ground-plan.

of unpressed slabs and blocks of native stone. On each of the other three sides of the chamber, at a height of 3 feet from the floor, there is a square opening to a cell or 'sepulchral loculus,' 3 feet high, 4 feet wide, and $5\frac{1}{2}$ to 7 feet long. Maeshowe was explored in 1861 by Mr James Farrer, M.P. when it was found to have been ransacked at least once before in the winter probably of 1152-53 by Norwegian, followers of Earl Rognvald, and pilgrims to Jerusalem. Their Runic inscriptions, comprising upwards of 900 letters, thickly cover the walls of the central chamber, and consist mainly of such inscriptions as 'Her-

mund Hordaya carved these runes.' There are carvings besides of eight crosses, a 'worn-knot,' and a nondescript animal. Mere idle scribbles, the runes afford no clue to the origin of the tumulus itself, which Dr Anderson assigns unhesitatingly to the 'Age of Stone,' whilst Fergusson ascribes its erection to Northmen and to a date so recent as 970.

See the article **CELLS**; Farrer, *Notes on the Ruins Inscriptions* (1862); *Proc. Soc. Ant. Scot.* (1867); James Fergusson, *Rede Stone Monuments* (1872); and Joseph Anderson, *Scotland in Pagan Times* (1886).

Maestricht, the capital of the Dutch province of Limburg, 19 miles NNE. of Liege by rail, 19 WNW. of Aix-la-Chapelle, and 152 SSE. of Amsterdam. It lies on the left bank of the Meuse or Maas, a stone bridge (1683), 133 yards long, connecting it with the suburb of Wilk. Formerly an important fortress, it is still a garrison town; but the fortifications were dismantled in 1871-78. The town-hall, with spire and carillon (1662), contains many paintings and a library; and in the three-towered church of St Servatius (12th-14th century), the cathedral once, is a 'Descent from the Cross,' by Van Dyck. But Maestricht's great sight is the subterranean quarries of the Piotersberg, formerly called *Mons Hannorum* (330 feet). Their labyrinthine passages, 12 feet wide, and 20 to 50 feet high, number 16,000, and extend over an area of 13 by 6 miles. They are supposed to have been worked first by the Romans, and, amongst other fossils, have yielded two heads of the huge *Mosasaurus* (q.v.). The manufactures include glass, earthenware, and carpets. Pop. (1876) 29,083; (1898) 34,362. Maestricht, the Roman *Trajectum ad Mosam*, was no less than six times besieged between 1579 and 1814, and in 1830 withstood the insurgent Belgians.

Maestricht Beds, a section of the Danian or uppermost subdivision of the Cretaceous System (q.v.). In Britain the chalk with flints is covered with Tertiary strata, but at Maestricht in Holland there occurs a thickness of 100 feet of soft yellowish limestone with a conglomeratic base, abounding in the remains of Corals and Polyzoa. The fossils are peculiar.

Maeterlinck, MAURICE, was born at Ghent in 1864, and became known to the world of Paris in 1890 by a play, *La Princesse Maline*. Other plays are *L'Entrée*, *Les Accablés*, *Pathos et Mélancolie*, and *Aglaraine et Schizette* (all translated into English); and he has shown his religious sympathies by a translation into modern Flemish of Roysbroeck the Mystic (1891).

Mafeking, a town in the north-east corner of Cape Colony, connected in 1894 with the railway system from Capetown. Hence in 1896 Jameson (q.v.) started on his disastrous raid into the Transvaal. On the outbreak of the Transvaal war in 1899 Mafeking was invested by the Boer forces, but was heroically defended by Colonel Baden Powell with a small garrison, and after a siege of seven months, was relieved on 17th May 1900.

Maffei, FRANCESCO SEMPIONE, MARCHESE DI, playwright and antiquary, was born at Verona, 1st June 1675, and studied in the Jesuit College at Parma. He spent the years 1703-4 in military service, under his brother Alessandro, a distinguished soldier and field-marshal, but ultimately devoted himself to literary pursuits. His tragedy of *Mejago* (1714) was so well received that it went through seventy editions in his own lifetime. His comedy of *Le Cerimonie* (1728) was also successful. *Verona Illustrata* (1731-32; new ed. 1827

is a work of much brilliancy and learning. After four years in France (1732-36) he visited England, Holland, and Germany, then settled in his birth-place, where he died 11th February 1755. A collective edition of his works was published at Venice in 1790, in 21 vols.

Mafia, a secret society in Sicily, more powerful than the Camorra (q.v.) of Naples, which has organised lawlessness, and made itself more feared than the law. Its code of honour (the *omertà*) binds the members to seek no redress from the courts, nor ever to give evidence before them; its object is to override the law, and to rule the island. In an organised form, however, the Mafia survives only in isolated localities; as it exists in the island as a whole, it rather expresses an idea than indicates a society with regular chiefs and councillors. It represents the survival among the people of a preference for owing the securing of their persons and property rather to their own strength and influence than to those of the law and its officers. Therefore a distinction is drawn between the high and the low Mafia, the latter embracing the great mass of members who, themselves not active in the matter, are afraid to set themselves against the Mafia, and are content to accept the protection of this shadowy league, which in them inspires more awe than do the courts of justice. Indeed, much of the Mafia's strength and vitality is directly due to this looseness of organisation, and to the fact that it is an ingrained mode of thought, an idea, and not an organised society, that the government has to root out. Direct robbery and violence are resorted to only for vengeance; for practical purposes the employment of isolation—in fact, the system of boycotting carried to the extreme point—is sufficiently efficacious. From the landholders blackmail is levied in return for protection, and they must employ *mafiosi* only on their farms; and the *culletta* follows those who denounce or in any way injure a member of the fraternity. The Mafia controls elections, protects its members against the officers of justice, assists smugglers, directs strikes, and even fixes the hire of workmen. The government's efforts have failed to stamp out the society; but numbers of its members have been driven abroad, and swelled the criminal classes of New York and New Orleans. See Alongi, *La Mafia* (Trin, 1887); Le Faure, *La Mafia* (Paris, 1892).

Mafra, a town of Portugal, 20 miles NW. of Lisbon. Pop. 3020. The palace, built by John V. in 1717-31 as a rival to the Escorial, is 770 feet long and 690 feet wide; contains 866 rooms, and a library of 30,000 vols.; but now serves as a barrack and military academy.

Magadoxo, or MUKDISH, a port on the east coast of Somaliland, 250 miles NE. of the mouth of the Juba river. Pop. 5000.

Magazine. See PERIODICALS. For Magazine Rifle, see RIFLE.

Magdala, a hill fortress and small town of Abyssinia (q.v.), 300 miles S. of Amesley Bay, on the Red Sea, stood perched on a plateau 9110 feet above sea level. It was the place of captivity of the British prisoners for whose rescue an expedition was sent out under Sir Robert Napier (Lord Napier of Magdala); and on 13th April 1868 the town was burned and its defences destroyed.

Magdalena, the principal river of Colombia, rises in the Central Cordillera, about 2° N. lat., and only 8 miles from the source of the Cauca. These streams flow north on either side of the Cordillera, uniting about 130 miles from the sea. The Magdalena, which ends in a large delta, is closed to sea-going vessels by a bar with dangerous shifting sands; merchandise is conveyed by a railway (18

miles) from Barranquilla to Puerto Colombia, the shipping port, where a pier has been built. The river is navigable to Honda, 500 miles, where the rapids begin; above these it has been navigated by a German steamer to Neiva since 1875, and a railway (20 miles) alongside the rapids connects the upper and lower sections. The Magdalena's drainage area is calculated at 92,900 sq. m.

Magdalene, MARY, or MARY OF MAGDALA, so named from a town near Tiberias, a woman 'out of whom Jesus cast seven devils,' and who believed in Him and followed Him. She was one of the women who stood by the cross, and one of those who went with sweet spices to the sepulchre. To her He first appeared after His resurrection. In consequence of an unfounded notion identifying her with the woman who had been a sinner, described in Luke, vii. 36-50, as having anointed our Lord's feet with ointment, and wiped them with her hair, Mary Magdalene has been long and generally regarded as a woman whose early life had been very profligate, although of this there is no hint whatever in the narratives of the evangelists; and the Magdalenes, so frequent amongst works of art, represent her according to this prevalent opinion. Our word *maudlin* (lit. 'weeping-eyed') is due to the same notion, and indeed the very name Magdalene has come to be applied to women who have fallen from chastity, and institutions for the reception of repentant prostitutes are known as *Magdalene Asylums*.

The conclusion of most commentators is that there were two anointings, one in some city unnamed during our Lord's Galilean ministry (Luke vii.), the other at Bethany before the last entry into Jerusalem (Matt. xxvi., Mark xiv., John xii.). The one passage adduced to prove that in these two narratives we have but one woman is John, xi. 2, and it has been argued by some that this could not possibly refer by anticipation to the history that follows in chap. xii. Against this it may be said that to impute a life of impurity to Mary of Bethany is to make an entirely gratuitous assumption. The evidence to identify Mary Magdalene with either actor in the two narratives is still less secure. The identity of Mary Magdalene with the sinner was first positively asserted by Gregory the Great in his *Homilies*, and the services of the feast of St Mary Magdalene were arranged on the assumption of its truth. But a great and growing consensus of opinion among the most competent scholars, and those not merely Protestant, is conclusive against it.

Magdalen Islands, a small group near the centre of the Gulf of St Lawrence, 54 miles NW. of Cape Breton Island. The largest is Collin's Island. The people are supported by the lobster, cod, herring, and seal fisheries. Pop. 3172.

Magdeburg, the capital of Prussian Saxony, and one of the chief fortresses of the German empire, 90 miles by rail SW. of Berlin and 72 N. of Leipzig. It lies in a cheerless country, on the left bank mainly of the Elbe, which, here 280 yards wide, branches into three channels, and forms two islands. On the smaller of these still stands the Citadel (1683-1702); but otherwise the old fortifications have since 1866 been built over or converted into promenades, their place being taken by a cordon of thirteen forts. The cruciform Gothic cathedral, rebuilt between 1207 and 1550, is 400 feet long, and has two western towers 341 feet high. It contains the tombs of the Emperor Otho the Great, of his first wife, the English princess Editha, and of Archbishop Ernest, whose monument (1497) is a masterpiece of Peter Vischer of Nuremberg. In front of the town-hall (1691-1866) is the equestrian statue of Otho, dating, not from 973 as its inscription

claims, but from the close of the 13th century; and of several other monuments the most noteworthy are the Soldiers' Memorial (1877) and a statue of Luther (1886). The industries are of high importance, comprising huge ironworks, distilleries, cotton-mills, &c.; and the trade is correspondingly great—for sugar it is the first market of Germany. Magdeburg is the junction of five railways; and the river-trade is also very large. Pop. (1875) 122,789; (1890) 202,324, of whom over 10,000 were Catholics, and 2000 Jews. Founded by Charlemagne in 805, and refounded by Editha after its destruction by the Wends in 924, Magdeburg was in 968 made the seat of an archbishopric, and had 40,000 inhabitants in 1524, when, embracing the Reformation, it incurred the combined wrath of emperor and papate. It weathered the storm then, successfully withstanding Maurice of Saxony (1550); but during the Thirty Years' War it suffered fearfully. In 1629 it was vainly besieged for twenty-eight weeks by Wallenstein; in May 1631, after an heroic defence (2000 against 25,000), it was taken by Tilly and burned to the ground, the cathedral (reconsecrated for Catholic worship) and a few poor fisher huts being almost all that remained after the three days' sack, in which nearly the whole population of 36,000 perished by fire or sword or drowning in the river. In 1648 the archbishopric was converted into a secular duchy, and conferred on the house of Brandenburg in compensation for the loss of Pomerania. In 1803 the French annexed it to the Kingdom of Westphalia; but in 1814 it was finally restored to Prussia. See works by Hoffman (2d ed. 1885), Kawerau (1886), and Guericke (2d ed. 1887); and for the *Magdeburg Centenary*, see CHURCH HISTORY, Vol. III, p. 242.

Magdeburg Hemispheres are two hollow hemispheres, generally made of copper or brass, with their edges accurately fitted to each other, and one of them furnished with a stopcock. When



Magdeburg Hemispheres.

the edges are rubbed over with grease, pressed tightly together, and the globe thus formed exhausted of air through the cock, the hemispheres, which fell asunder before exhaustion, are now pressed together with immense force—e.g. if they are one foot in diameter, they will, after exhaustion, be pressed together with a force of nearly a ton. This experiment was first performed by Otto von Guericke (q.v.), burgomaster of Magdeburg, in 1659, at the imperial diet at Ratisbon, to the astonishment of the Emperor Ferdinand III. and his princes and nobles.

Magellan, FERDINAND (Portuguese *Magalhães* or *Magellans*), a famous navigator, was born about 1470, most probably at Villa de Sabrosa, near Villa Real in Feuzos Montes. He served with distinction in the East Indies, particularly at Malacca, and was banished for life in action in Morocco. Finding his sufferings rewarded with contempt by King Manuel he formally renounced his nationality, and together with his countryman, Roy Valera, a geographer and astronomer, offered his services to Spain. They laid before Charles V. a scheme for reaching the Moluccas by the west, which was well

received; and Magellan sailed from San Lúcar, 10th August 1519, with five ships of from 130 to 60 tons, and about two hundred and fifty men. Sailing to the mouth of the La Plata and along the shores of Patagonia, he threaded the strait which bears his name (21st October—28th November 1520), and entered on that vast ocean which he named the Pacific from the fine weather which he experienced there. He had already been troubled by mutiny, which he had crushed by swift vengeance upon the ringleaders, and after reaching the Philippine Isles he fell in an expedition against the natives of Mactan (27th April 1521). His ship, the *Victoria*, was safely navigated by Sebastian del Cano home to Spain, and thus completed, on 6th September 1522, the first voyage ever made round the world.

The best contemporary account of Magellan's famous voyage is that by Antonio Pigafetta, a volunteer in the fleet. An English version of this and five minor narratives is Lord Stanley of Alderley's *First Voyage round the World by Magellan* (H. Kluwert Society, 1874). See Guillemaud, *Magellan and the Pacific* (1891).

MAGELLAN STRAIT, separates South America on the south from Tierra del Fuego. It is 375 miles in length, and its breadth varies for the most part between 12 and 17 miles. It was discovered by Magellan in 1520, and first thoroughly explored by King and Fitzroy in the *Adventure* and *Beagle* (1826-35). The wider eastern half is bordered by level, gently-rolling grassy plains. The narrower western half is shut in by steep, wooded mountains; the current runs strong through it, and the west winds are a great hindrance to sailing-vessels. There are several fine harbours along this part of the strait. See works by R. O. Cunningham (Edin. 1878) and A. W. Miller (Portsmouth, 1884).

Magellanic Clouds, or **NEBULÆ MAJOR** and **MINOR**, two cloudy masses of light seen at night in the sky of the southern hemisphere. The greater lies between R.A. 4h. 40m. and 6h., and N.P.D. 156° and 162°; the lesser between R.A. 0h. 28m. and 1h. 15m., and N.P.D. 162° and 165°. They are composed of complex masses of nebule and stars, condensed so as to give the naked eye the impression of a cloudy mass. See **NEBULÆ**.

Magendie, FRANÇOIS, an eminent French physiologist and physician, was born at Bordeaux, 15th October 1783; studied at Paris, became successively professor in anatomy (1804), physician to the Hôtel-Dieu, member of the Academy of Sciences (1819), and professor of Anatomy in the Collège de France (1831). He made important additions to our knowledge of nerve physiology, the veins, and the physiology of food, and wrote numerous works, including the *Elements of Physiology* (originally a précis, 1816, afterwards extended). He was likewise the founder, and for ten years the editor, of the *Journal de la Physiologie Expérimentale*, in which are recorded many of the experiments on living animals which gained for him, too deservedly, the character of an unscrupulous vivisector. He died 7th October 1855.

Magenta, an Italian town, 18 miles W. of Milan by rail. Pop. 5573. Here, on 4th June 1859, 55,000 French and Sardinians defeated 75,000 Austrians, the latter losing 10,000, besides 7000 prisoners, and the allies only 1000. For this victory MacMahon received his dukedom. For the coal for colour, see **DYEING**.

Magorö. See **NORTH CAPE**.

Maggiore, Lago, one of the largest lakes in Italy, the *Lacus Fimbrius* of the Romans, is situated for the most part in Italy, but also partly in the Swiss canton of Ticino. It is 39 miles in length, and varies in breadth from 3 mile to 5½ miles. It lies 616 feet above the level of the sea,

and has a maximum depth of 1158 feet. The river Ticino flows through it. In a south-western expansion of the lake are the Borromean Isles (q. v.). On the north and west it is surrounded by granitic mountains, 7000 feet high, on the south and east by vineyard-covered hills.

Maggot, the larva of most flies (Diptera), without limbs or distinct head. They feed on the animal material, often a corpse of some sort, in which they are laid. Some of the larger forms are used for bait or for feeding birds.

Magi. In Accadian, the language of the early Turanian inhabitants of Babylonia and Media, *magu*, signifying 'angust,' 'reverend,' was the title of their learned and priestly caste. The Semitic nations afterwards dominant in Babylonia and Assyria adopted the learning and many of the religious observances of the early inhabitants, as also the name for the learned caste; and out of the Semitic form the Greeks made *magos*. Under the Persian empire the magi were not only the 'keepers of the sacred things, the learned of the people, the philosophers and servants of God,' but also diviners and mantics, augurs and astrologers. They called up the dead by awful formulas, or by means of cups, water, &c. They were held in the highest reverence, and no transaction of importance took place without or against their advice. Hence their almost unbounded influence in both private and public life. Apart from the education of the young princes being in their hands, they were the constant companions of the ruling monarch. Of their religious system the articles PARSLES and ZOROASTER will give a fuller account. Zoroaster, in the course of his great religious reform, reorganised the body of the magi, chiefly by reinforcing the ancient laws as to their manner and mode of life, which was to be one of the simplest and severest, belittling their sacred station, but which had become one of luxury and indolence, and by re-instituting the original distinction of the three classes of *hurobs* ('disciples'), *mobeds* ('masters'), and *dshur mobeds* ('complete masters'). The food, especially of the lower class, was to consist only of flour and vegetables; they wore white garments, slept on the ground, and were altogether subjected to the most rigorous discipline. The initiation consisted of the most awful and mysterious ceremonies, and was preceded by purifications of several months' duration. Gradually, however, their influence, which was all-powerful during the epoch of the Sassanian kings of Persia, began to wane, and, from being the highest caste, they fell to the rank of wandering jugglers, fortune-tellers, and quacks, and gave their name (Magic, q. v.) to sleight-of-hand and conjuring tricks. But the name seems to have been also current as a generic term for astrologers in the East, as is evidenced by the New Testament narrative of the homage of the Magi to the Infant Christ.

According to the narrative (Matt. ii, 1-12) the three wise men came from the East to Jerusalem, led by a star, which at length guided them safely to the place of the Nativity at Bethlehem, where they offered their gifts of gold, frankincense, and myrrh. As the 'Three Kings' their names became celebrated in the middle ages, and Bede distinguishes them as Kaspar, Melchior, and Balthasar. The last was the Chaldean name for Daniel; Melchior signifies 'king of light'; Kaspar in some legends appears as Gathaspar, and in Syriac sources as Gudophorhem, in which we may perhaps recognise the name of the powerful Indo-Parthian king, Gondophares, said to have been baptised by the apostle Thomas. The bones of the three kings are claimed to be deposited in the cathedral at Cologne. In the calendar the three days after New-year's

Day bear their names, and their memory is preserved in the feast of the three holy kings—the Epiphany. The youngest of the three is generally represented in works of art as a black man.

Magic, the pretended art of doing wonderful works by aid of mysterious supernatural means. The term is in general synonymous with sorcery, and was originally applied by the Greeks and Romans to that form of sorcery which was communicated by the Babylonian *Magi* to the Medes, Persians, and Parthians, and by them spread over the East and even the West. No people have carried magic to a greater height than the ancient Chaldeans, and many of their formulas of propitiation and expulsion of spirits and demons have been deciphered from the cuneiform inscriptions. They practised many forms of magic, but especially astrology, which was misused by a succession of astronomers to the dignity of a pseudo-science. In the same way Egyptian magic was formulated into elaborate system and ritual which far surpassed in completeness anything to be found among the ancient Greeks or Romans. The former held the same views of magic as the less cultured races around them, and the philosophy of the Pythagoreans and Neoplatonists carried mystical symbolism and magical speculations further into new regions of theurgy and thaumaturgy. Theurgic magic also was highly developed in Alexandria, and it descended into medieval and modern Europe bearing many marks of Jewish speculation.

Grimm says *Miracle* (*wundern*) is the salutary, Magic (*zöubern*) the hurtful or unlawful, use of supernatural powers; miracle is divine, magic devilish; not till the gods were degraded and despised was magic imputed to them. Man can heal or poison by directing natural forces to good or to evil; sometimes he even shares the gift of miracle; but when he pushes the beneficent exercise of his powers to the supernatural point, he learns to conjure. The origin of all conjuring must be traced directly to the most sacred callings, which contained in themselves all the wisdom of heathendom—viz. religious worship and the art of song. Sacrificing and singing came to mean conjuring; the priest and the poet, confidants of the gods and participants of divine inspiration, stand next door to the fortune-teller and magician. By the side of divine worship practices of dark sorcery grew up by way of exception, not of contrast. After the introduction of Christianity all heathen notions and practices were declared to be deceit and sinful delusion; the old gods fell back and changed into devils, and all that pertained to their worship into devilish jugglery. Presently there sprang up tales of the Evil One's immediate connection with sorcery and witchcraft; and out of this proceeded the most incredible, most cruel jumbling up of imagination and reality. The great distinguishing mark of sorcery was the desire to work mischief, and thus this delimitation involves the same ethical condemnation which made Plato denounce sorcery as an illegitimate method of forcing the power of the gods into the service of man. It was from the beginning the inveterate antagonist of religion, originating in dim and confused yet independent glimpses into the secrets of nature; and throughout it we trace the elemental idea of an opposition to the divine will, it being implied that the power of influencing and altering his physical conditions rests within the power of man himself. The sorcerer stands aloof from the ordinary adoration of supernatural powers, employing occult faculties and devices which he supposes to be within his own control. Hence sorcery early becomes differentiated from religion—on the one side legitimate means of contact with the divine, as adoration, inspiration, vows, oracles, miracles,

omens, and signs; on the other, thaumaturgy by occult, incomprehensible arts, skill in natural magic, mesmerism, mumbo-jumbo, and imposture. Originally magic was the rudimentary beginning of medicine and science, but soon it fell back into occult and mystic devices, while two elements present in its first inception—the religious sentiment and real experimental knowledge—developed into morality and science. Magic, says Bastian, is the physics of mankind in the state of nature. It rests on the beginning of induction, which remains without result only because in its imperfect judgments by analogy it raises the *post hoc* to the *propter hoc*. The notion that the gods were indifferent to the fate of mortals opened a door to sorcery for finding relief from suffering, but gradually the deteriorating influences made way and the criminal side of the miraculous became specially the function of the eratt. Modern India, says Sir Alfred Lyall, swarms with astrologers, soothsayers, and interpreters of dreams, who watch nature to ascertain the will of the gods; but these are quite distinct from the sorcerers, who work independently of them, and soon become knaves and cheats, religious and medical, preying upon the ignorance of their dupes. Among the Mohammedans magic is rife, though condemned by rigid divines; and almost everybody believes in the efficacy of amulets, charms, spells, exorcism, magic mirrors, cabalistic figures, divination, sortilege, and the like. If a man devotes the power he acquires to good ends he is held comparatively innocent; but he may go on to acquire the power of commanding the evil genii to do him all kinds of wicked service, which is execrated as black or Satanic magic.

The superstition of magic and witchcraft belongs essentially to the lower levels of civilisation, and the reputation of it clings to any survivors of an older nationality, like the Lavas of Burma and the Finns and Lapps among their Scandinavian neighbours. Even in Scotland robust Presbyterians long thought more highly of the Popish priests than of their own clergy for casting out devils, laying ghosts, and curing madness. All magical reasoning is based upon the inherent belief of primitive man that casual connection in thought is equivalent to causal connection in fact. The savage ever confounds an ideal with a real connection; he confuses subjective and objective relations. To him it is merely a matter of experience that all nature is personal and animate, and that human agencies can work supernaturally. He is constantly seeking an explanation of physical facts, and he fills up his scanty knowledge of natural causes with hypothetical causes of a metaphysical and supernatural character. This confusion of imagination and reality produces a state of mind capable of accounting for the whole business of magical arts and magical relations, the only real connection between which is mere analogy and symbolism. Coincidences ever strike the primitive man as things in themselves significant, and *post hoc ergo propter hoc* is to his mind a perfectly valid logical method. Nor does his sorcerer always need to be successful—one lucky hit outweighs half a dozen failures, and the sorcerer, through a kind provision of nature, usually ends with being himself more or less the dupe of his own powers. Thus magic may develop into elaborate and systematic pseudo-science, a sincere though fallacious philosophy evolved by processes in great measure still intelligible to our own minds. Augury, divination, oneiromancy, chiromancy, and astrology admitted of being gravely formulated and discussed, and even among 19th century Englishmen and Americans may be seen not a few strange revivals of magicians like Apollonius

of Tyana and Iamblichus, as well as of savage philosophy and peasant folklore, in the freaks of so-called spiritualism, with its voices, its spirit-writing, its untying of ropes, and its rising and floating in the air.

The primitive mind ever needs material support for the religious sentiment, and in this constant condition we find the foundation of fetishism and idolatry. Everywhere the savage sees a connection between an object and a visible representation of it; hence the philosophy of making an image of a person to be injured by burning it, melting it away, or sticking pins into it—of which we have still a surviving shadow in our custom of burning an unpopular person in effigy. Again, a disease tormenting a man may be driven into an image of clay or the like, and in the same elemental idea of connection between object and image we find explanation of the fear of clippings of the hair or parings of the nails falling into the possession of an enemy, our own lingering liking for locks of hair of those we love, as well as many of the usages of early medicine, sympathetic powder, love-potions, the doctrine of Signatures (q.v.). A similar connection exists somehow between a thing and its name; hence a man may be bewitched through a wicked use of his name, and a sorcerer may force the hand of a divinity by invoking with his name. Accordingly, in the history of primitive religions we find the most sacred names kept strictly secret, as by the Jews, Moslems, and the Romans of their tutelary deity.

Magic was strictly condemned under the Levitical law, and by the early Christians was regarded as unlawful miracle. In the middle ages it continued to be studied in its less harmful sides, as astrology and alchemy, and it must not be forgotten that in the one department it was the parent of scientific astronomy, in the other of modern chemistry. Yet the reign of imperfect analogy has given way but slowly before a real scientific method; and though the old theory of demoniacal possession has been exchanged for a real knowledge of the laws that govern lunacy, and occult sympathetic operations have widened out into the vast sciences of pharmacy and medicine, yet primitive magical conceptions still cling closely to our people, and form everywhere the heart of popular folklore.

See the articles ALCHEMY, ANIMISM, ASTROLOGY, DEMONOLOGY, DIVINE DIVINATION, FETTERISM, FOLK-LORE, IDOLATRY, INCANTATIONS, and WITCHCRAFT; also EMMENAGER, *Geschichte der Magie* (2d ed. 1844; trans. by W. Howitt, 2 vols. 1854); Maury, *La Magie et l'Étiologie* (4th ed. 1877); Lenormant, *La Magie chez les Chaldéens* (1874; Eng. trans. 1877); Victor Rydberg, *Magie of the Middle Ages* (Eng. trans. New York, 1879); and Fabart, *Histoire philosophique et politique de l'Occulte, Magie*, &c. (1885); also Caspari, *Ursgeschichte der Menschheit* (2d ed. 1877), and Tyler's *Early History of Mankind* (chap. vi.) and *European Culture* (chap. iv.). Horst's *Zauberabhandlung* (6 vols. Manz, 1820-26) is a perfect cyclopaedia of the doctrine and methods of magic; a complete bibliography of its literature is Grasse's *Bibliographie der neuesten in das Gebiet des Zaubers, Geistes, und sonstigen Aberglaubens einschlagenden Werke* (Leip. 1843).

Magic Lantern, an optical instrument said to have been invented by Athanasius Kircher in 1646, by means of which magnified images of small pictures are thrown upon a wall or screen. The instrument consists of a lantern containing a powerful argand lamp or lime-light arrangement (see LIME LIGHT); in the side of the lantern is inserted a horizontal tube, the axis of which is on a level with the centre of the flame, and the light is generally made to pass through the tube by reflection from a concave mirror placed on the opposite side of the lantern. The tube is furnished with two lenses, one at each end; the inner one, the condenser, is a large lens

of short focus, to condense a strong light on the picture, which is inserted into the tube, between the lenses, through a transverse slit. The other end of the tube is fitted with a double convex lens, or, better, a corrected combination of lenses, which receives the rays after passing through the picture, and throws them upon the screen or wall. The pictures are formed on glass slides—generally $3\frac{1}{2}$ inches square—with transparent coloured varnish or by means of photography on a collodion, gelatine, or carbon tissue film on the glass, and must be inserted into the tube in an inverted position, and with the film or painted side nearest the screen, in order that the images may appear erect and un-reversed. If the screen on which the image is thrown be at too great a distance, the image will become indistinct from the lessened intensity of the light. This instrument is sometimes used as a toy, but is also frequently employed to produce enlarged representations of astronomical and other scientific diagrams, and enlargements of photographic views, so that they may be well seen by an audience. Phantasmagoria, dissolving views, &c. are produced by a particular manipulation of the same instrument.

Magic Squares are sets of different numbers, each column of which, whether horizontal, vertical, or diagonal, adds alike.

1	1872	10	8
12	6	3	1870
7	9	1873	2
1871	4	5	11

Fig. 1.

420	508	453	510
523	449	471	457
479	441	539	492
469	502	428	492

Fig. 2.

The above are two examples of a magic square with the same summation (in either case 1891). Considering the difficulty with which a person without previous knowledge could make even one such square, it may surprise many to hear that there are more than 700,000,000,000,000 (seven hundred billion) magic squares of this sort (4), with the summation of 1891, each composed of different numbers, or with a different arrangement of the same numbers. Fig. 1 is so constructed that a great variety of other squares may be made from it by altering the four highest numbers in it. Thus, if 13, 14, 15, and 16 be substituted for 1870, 1871, &c. respectively, we get the smallest 4-square possible, with the summation 34. It was at one time thought that magic squares could only be composed of arithmetical or other symmetrical series of numbers; but an examination of Fig. 2 shows that that idea was erroneous.

Within the compass of a short article it is impossible to describe adequately any of the many rules for making magic squares. The following figures will, however, give some idea of the most important method, that of superposition, invented by De la Hire. It is most readily applied to odd squares, more especially to those whose roots are prime numbers. We therefore take the 5-square for our example.

1	3	5	2	4
5	2	4	1	3
4	1	3	5	2
3	5	2	4	1
2	4	1	3	5

Fig. 3.

5	0	15	10	20
10	20	5	0	15
0	15	10	20	5
20	5	0	15	10
15	10	20	5	0

Fig. 4.

Each row of the above squares contains the same

numbers and in the same order relatively to one another. But in fig. 3 the first number of each row is the same as the *third* of the row above, whilst in fig. 4 it is the *fourth*. If now these two squares be combined by adding together the numbers that are in corresponding cells, the resulting square will be magic. In this case it will have the summation of 65, and the top row will be 6, 3, 20, 12, 24. By altering the positions of the numbers in the top rows, and making corresponding alterations in the others, 3600 distinct varieties of this magic square may be obtained.

Although numerous persons have written on magic squares (among whom may be mentioned Leibnitz, Frenicle, De Morgan, Bachet, Ozanam, Montucla, Frost, and Cramé), the literature on the subject is by no means easily accessible. Perhaps the best known work is Hutton's *Mathematical Recreations*; and in this will be found descriptions of other kinds of magic squares, such as the Bordered and Tessellated, which may briefly be described as magic squares within magic squares. *Nasik* magic squares (so named by Frost from his place of residence in India) are squares whose magicality is not destroyed by repeatedly removing the first column or row to the last place, or *vice versa*. All squares with prime roots, made by De la Hire's method of superposition, are *nasik*. Even squares can also be made *nasik*. Fig. 1, with the numbers 13, 14, 15, and 16 substituted for the four highest, makes a *nasik* square.

Magilp. or MEGILP, a composition used by artists in oil-colours as a medium and for glazes. It is made of linseed-oil and mastic varnish. Robertson's medium, which is similar but dries quicker, is now more used than magilp.

Magilus, a remarkable Gasteropod found on the coral reefs of warm eastern seas. The young animal settles on the growing coral at the obvious risk of being gradually surrounded and smothered. This is avoided, however, by an entire change in the form of the shell, which is diverted from its original spiral type and grows out into a long irregular tube. 'A neck-and-neck race is kept up until the mollusc or the coral dies.' As the tube lengthens sometimes to 2 or 3 feet the animal shifts into it completely, and the original whorls are filled up with lime.

Maginn, WILLIAM, one of the most brilliant writers of his day, born at Cork, 10th July 1793, the son of a schoolmaster, and educated at Trinity College, Dublin, where he graduated B.A. in 1811, and left a brilliant reputation for precocious scholarship. At twenty-six he received his degree of LL.D. from his college, being the first who had ever received it so young. He taught in Cork for ten years, and in 1823 removed to London to pursue the life of letters. His first contribution to *Blackwood's Magazine*—a Latin translation of *Cherry Chase*—appeared in 1819, and from that date for nine years scarcely a number appeared without an article from his pen. In 1821 Murray started the short-lived *Representative*, a daily newspaper, and Maginn was sent to Paris to act as foreign correspondent. In 1828 he joined the staff of the *Standard*, and was one of the originators of *Fraser's Magazine* in 1830. His contributions to *Fraser* were as 'lively, learned, and libellous' as those to *Blackwood*, and one led to a harmless duel between the author and the Hon. Grantley Berkeley. The remainder of Maginn's career was irregular and unhappy. His habits of intemperance gained the mastery over him, and he was often arrested and in jail for debt, without losing, however, in the least his brightness or good-humour. He wrote his *Shakespeare Papers* for Blackwood in 1837,

and in 1840 he began his *Magazine Miscellanies*, by *Doctor Maginn*, which did not extend beyond ten numbers. In 1842 he was again imprisoned in the Fleet, and, having passed through the bankrupt court, was reduced in fast failing health to a state of great poverty. Help came from Sir Robert Peel almost too late, for poor 'bright, broken Maginn' died at Walton-on-Thames, 21st August 1842. He wrote two forgotten romances, *Whitehall, or the Days of George II.* (1827, a parody on the historical novel, and Horace Smith's *Brambletop House* in particular), and *John Manesty* (1844), completed after his death by Charles Ollier. His *Homeric Ballads* were published in 1849. A collection of his papers was edited by R. S. Mackenzie (5 vols. New York, 1855-57); and his *Miscellanies, Prose and Verse*, by R. W. Montagu (2 vols. Lond. 1885).

Magistrate. See BOROUGH, and JUSTICE OF THE PEACE.

Magliabechi. ANTONIO, bibliophile, was born at Florence in 1633, and till his fortieth year was a goldsmith. From youth upwards, however, he displayed an inordinate passion for the acquisition of book-knowledge; and, having mastered Greek, Latin, and Hebrew, he literally entombed himself among books, of which disorderly piles encumbered every portion of his dwelling. In his daily habits he grew regardless of the decencies of life; and such was his avidity of study that he finally denied himself even the requisite intervals of repose. His memory was prodigious, and enabled him not only minutely to retain the contents of his multitudinous books, but also to supply, on occasion, the most exact reference to any particular page or paragraph, the place of each book being indicated with precision in the midst of their seemingly inextricable masses. Magliabechi was regarded as the literary prodigy of his times. In 1673 he was appointed court-librarian by the Grand-duke of Tuscany; and the many tributes of respect tendered by royal and distinguished personages to his wonderful erudition fostered in an inordinate degree his love of fame and praise, which rendered him intolerant of literary merit in others, and involved him in several bitter literary squabbles. He died at Florence on 4th July 1714, leaving no written record of his immense encyclopædic knowledge. His valuable library of 30,000 vols. he bequeathed to the Grand-duke, who made it over to the city of Florence; it is now a fine library, and bears the name of its collector. See John Hill Burton's *Book-Hunters* (1862).

Magna Charta. the Great Charter granted by King John of England to the barons, has since that time been viewed as the basis of the English constitution. The oppressions of a tyrannical sovereign compelled a confederacy of the barons or tenants-in-chief of the crown, who took up arms for the redress of their grievances. They demanded the restoration of the laws of Edward the Confessor and Henry I.; laws which combined Norman feudalism with Saxon and Danish institutions. A conference was held at Runnymede, on the Thames near Egham, where king and barons encamped opposite each other; and, after several days' debate, John signed and sealed the charter with great solemnity on 15th June 1215.

The Great Charter provided against the abuse of the royal prerogative by protecting the rights and obligations of the feudal proprietor. It redressed a variety of grievances connected with feudal tenures, some of which are long since obsolete. Minute provisions were made regarding the ward, relief, and marriage of heirs, and rights of their widows. No sentence or aid was to be imposed without the authority of the common council of the kingdom,

except on the three great feudal occasions of the king's captivity, the knighting of his eldest son, and the marriage of his eldest daughter. The liberties of the city of London and other towns, burghs, and ports were declared inviolable. Freedom of commerce was guaranteed to foreign merchants. Justice was no longer to be sold, denied, or delayed. The Court of Common Pleas, instead of, as formerly, following the king's person in all his progresses, was permanently fixed at Westminster, assizes were appointed to be held in the several counties, annual circuits established, and regulations made for the efficiency of the inferior courts. Life, liberty, and property were protected from arbitrary spoliation, and none was to be condemned to forfeit these but by lawful judgment of his peers or by the law of the land. No one was to be condemned on rumours or suspicions, but only on evidence of witnesses. Fines imposed were in all cases to be proportioned to the magnitude of the offence, and even the villain or rustic was not to be deprived of his necessary chattels. The testamentary power of the subject was recognised over part of his personal estate, and the rest was to be divided between his widow and children. The independence of the church was also provided for.

These are the most important features of that Charter which occupies so conspicuous a place in history, and which establishes the supremacy of the law of England over the will of the monarch. A charter was at the same time granted to mitigate the oppressions of the Forest Laws (q.v.). The terms dictated by the barons to John included the surrender of London to their charge, and the Tower to the custody of the primate till the 15th of August following, or till the execution of the several articles of the Great Charter. Twenty-five barons, as conservators of the public liberties, were empowered to make war against the sovereign in case of his violation of the Charter. Several solemn ratifications were required by the barons both from John and from Henry III.; and a copy of the Great Charter was sent to every cathedral, and ordered to be read publicly twice a year. The copy preserved in Lincoln Cathedral is regarded as the most accurate and complete; and a fac-simile of it was published by the Records Commissioners in 1865. See Bishop Stubbs's *Selct Charters* (1870).

Magna Græcia (Gr. *Μαγνητ. Ελλάς*), the name given in ancient times to the Greek colonies of Southern Italy. The appellation must have been current at an early period. Polybius says it was used in the time of Pythagoras. Some writers include under the term the Greek cities in Sicily, others restrict it to those situated on the Gulf of Tarentum; but in general it is used to denote all the Greek cities in the south of Italy, exclusive of those in Sicily. The oldest settlement is believed to have been Cumæ, though it is doubtful whether it and its colonies, Dicearchia and Neapolis, were really embraced under the designation Magna Græcia. The period assigned to its foundation soon after the Trojan war is obviously fanciful. The other more important Greek settlements in Italy were Sybaris (founded by the Achæans, 729 B.C.), Croton (by the Achæans, 710 B.C.), Tarentum (by the Spartans, 707 B.C.), Locri (by the Locrians, 710 B.C.; according to others, thirty or forty years later), Rhegium (by the Chalcidians; date of origin not known, but believed to be earlier than Sybaris), Metapontum (by the Achæans, 700 B.C.), Siris (by Ionians; date unknown), and Velia (by the Phœceans, 540 B.C.). These cities became in their turn the parents of many others. Of the earlier history of Magna Græcia very little authentic information has survived. The settlements appear to have risen rapidly to power and wealth, partly by the brisk commerce which they

carried on with the mother-country, and partly also, it is conjectured, by an amalgamation with the Pelasgic (and therefore kindred) natives of the interior, as at Lœri. About 530 B.C. Pythagoras, the philosopher, arrived at Crotona, and soon acquired supreme influence in Magna Grœcia, though it did not last long. The quarrels between the different cities were often bitter and bloody; the most notable cases were the destruction of Siris by the Achaean cities and of Sybaris by Croton (510). Besides this they were hotly pressed at times by the Lucanians and Bruttians; and finally, 272-271 B.C., the Romans conquered the whole of Lower Italy. Long before this several of the cities had disappeared. The longest to survive was Tarentum.

See the separate articles on the cities; also Lenormant, *La Grande Grèce* (3 vols. 1881) and *Les Grecs d'Asie Mineure* (2 vols. 1883), or the more popular *Land of Magnolia*, by Mrs. Janet Ross (1889).

Magnesia. See MAGNESIUM.

Magnesia, an ancient city of Ionia in Asia Minor, situated nearly 10 miles N.E. of Miletus in the valley of the Meander. It was a wealthy and prosperous city until after it fell into the hands of the Romans, in spite of its having been destroyed during the Cimmerian invasion about 660 B.C. Here stood a famous temple to Artemis, the remains of which have been excavated; and here Themistocles, the Athenian patriot and statesman, died (449 B.C.). It was called *Magnesia ad Meandrum*, to distinguish it from another, *MAGNESIA AD SIPYLUM*, which stood on the Hermus, near Mount Sipylus. Beside this town Scipio defeated Antiochus of Syria in 190 B.C. It is now called Manissa, and is a town of 50,000 inhabitants, 41 miles N.E. of Smyrna by rail.—The easternmost division of ancient Thessaly in Greece also bore this name.—To one of the places called Magnesia, most probably that in Lydia, we owe the terms magnet, magnetism, magnesia, and apparently also manganese.

Magnesian Limestone. See DOLOMITE.

Magnesium (sym. Mg, equiv. 24) is a metal which is very widely distributed over the globe. It is present in many minerals—e.g. dolomite—a carbonate of lime and magnesia; asbestos—a silicate of lime and magnesia; and meerschaum—a silicate of magnesia. It exists in mineral waters and in the sea as sulphate, and as chloride, the former being known as Epsom salts. It was from the Epsom spring, in 1695, that Drew extracted this well-known salt, and in the beginning of the 18th century *Magnesia alba*, so called to distinguish it from what was already known as *Magnesia nigra* (black oxide of manganese, so called from its resemblance in colour, weight, &c. to the magnet) was discovered. The metal was first prepared by Davy, and for long its manufacture was limited to a small scale. Now, however, it is made in quantity by fusing together the chlorides of potassium and magnesium and fluor spar, and adding metallic sodium with great care. The crude metal is finally distilled and pressed in a semi fluid state into ribbon or wire.

Magnesium has a silver-white colour, which is tarnished by moist air. It is a very light metal, its specific gravity being only 1.75. It is readily volatile, and, when lighted, burns in air with an intensely brilliant light rich in chemical rays. On this account it was, till superseded by the electric light, much used in photography, while in signalling and pyrotechny it plays an important part.

When magnesium burns in air it forms a white ash consisting of the oxide, magnesia, MgO (which may be also prepared by heating the carbonate). This is a very infusible substance, and is much

used in medicine under the name of calcined magnesia. The carbonate, MgCO₃, is found in nature, but for medical purposes it is prepared by precipitating a soluble magnesium salt with carbonate of soda. According as it is prepared in the hot or cold, the resulting carbonate forms the ponderous and dense or the light variety. Although insoluble in water, this substance readily dissolves in water containing carbonic acid, and this solution is known as fluid magnesia. The sulphate, MgSO₄·7H₂O, or Epsom salts, occurs in nature, and is well known as a domestic remedy. It is much employed in febrile affections, but it may be used in any case in which a mild but efficient laxative is required. Its dose varies from ʒ to ʒi ounce, but in order to promote its full efficacy it should be taken along with copious draughts of water. In combination with infusion of senna it forms the ordinary black draught. Magnesia and the carbonate are employed in small doses as an antacid, but in larger quantity they have a distinct purgative action. Fluid magnesia (see above) is a valuable aperient for women and children. Citrate of magnesia is the popular name for a granular, effervescent aperient, now much in use. It consists of a mixture of bicarbonate of soda, tartaric and citric acids, sugar, and a small trace (1 to 5 per cent.) of Epsom salts.

Magnetic Belts. See ELECTRICITY (MEDICAL).

Magnetism (*magis* or *lithos magnētēs*, 'the loadstone,' probably first found at Magnesia in Lydia). Magnets are natural (Loadstone, q.v.) or artificial, permanent (steel masses magnetised by the action of other magnets or of an electric current) or temporary (soft iron masses magnetised by magnets, or the so-called electro-magnets, soft iron masses round which a current is passing).

Polarity of the Magnet.—When a small soft iron, nickel, or cobalt ball is suspended by a thread, and a magnet (fig. 1) is passed along in front of it from one end to the other, the ball is powerfully attracted towards the ends, but not at all by the middle of the magnet. The points of the magnet towards which the attractive power becomes greatest are called its poles. By causing a small magnetic needle moving horizontally to vibrate in front of the different parts of a magnet placed vertically, and counting the number of vibrations, the rate of variation of the attractive power may be exactly found. When the poles of one magnet are made to act on those of another a striking dissimilarity between the poles is brought to light. To show this, let us suspend a magnet, NS, fig. 2, by a band of paper, M, hanging from a cocoon thread (a thread without torsion); or let us pivot it, or lay it on a float on water. When the magnet is left to itself it takes up a fixed position, one end keeping north, and the other south. The north pole cannot, except in unstable equilibrium, be made to stand as a south pole, or *vice versa*; for, when the magnet is disturbed, both poles return to their original positions. Here, then, is a striking dissimilarity



Fig. 1.

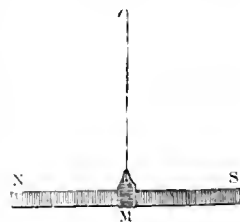

Fig. 2.

in the poles, by means of which we are enabled to distinguish them as *north pole* and *south pole*. When thus suspended, let us now try the effect of another magnet upon it, and we shall find that the pole of the suspended magnet which is attracted by one of the poles of the second magnet is repelled by the other, and *vice versa*; and where the one pole attracts, the other repels. If, now, the second magnet be hung like the first, it will be found that the pole which attracted the north pole of the first magnet is a south pole, and that the pole which repelled it is a north pole. We thus learn that *each magnet has two poles, the one a north, and the other a south pole, alike in their power of attracting soft iron, but differing in their action on the poles of another magnet, like poles repelling, and unlike poles attracting each other.*

The attractions and repulsions are found in a bar magnet to follow the same laws of distribution as would have been obeyed by the forces due to two equal isolated discs, the one attracting, the other repelling, and situated at points a little short of the extreme ends of the bar; and the places where these imaginary discs of imaginary magnetic matter would be are called the poles of the magnet. This conception of imaginary magnetic matter greatly facilitates many calculations, and is largely applied. It is as if the one kind of pole consisted of positive, the other of negative matter; and the north pole of a magnet is, in accordance with this order of ideas, conventionally termed the positive pole.

No Isolated Poles.—If we try to cut a bar-magnet so as to isolate the poles, we find that each half has developed a new pole at the broken end, and each half has become a separate magnet whose poles are equal to one another, and to the poles of the original magnet. *We can therefore never have one kind of magnetism without having it associated in the same magnet with an equal amount of the opposite magnetism.*

The Earth a Magnet.—The fact of the freely suspended magnet taking up a fixed position has led to the theory (Gilbert, q.v., in 1600) that the earth itself is a huge magnet, having its north and south magnetic poles in the neighbourhood of the poles of the axis of rotation, and that the magnetic needle or suspended magnet turns to these as it does to those of a neighbouring magnet. All the manifestations of terrestrial magnetism (q.v.) give decided confirmation of this theory. It is on this view that the French call the north-seeking pole of the magnet the south pole (*pôle austral*), and the south-seeking the north pole (*pôle boréal*); for, if the earth be taken as the standard, its north magnetic pole must attract the south pole of other magnets, and *vice versa*. In England and Germany the north pole of a magnet is the one which, when freely suspended, points to the north, and no reference is made to its relation to the magnetism of the earth.



Fig. 3.

Fig. 3 is a horseshoe magnetic magazine. The central lamina protrudes slightly beyond the other, and it is to it that the armature is

attached, the whole action of the magnet being concentrated on the projection. The magnetic needle is a small single permanent magnet nicely balanced on a fine point. See COMPASS.

The Magnetic Field. The region surrounding a magnet (even, to a diminishing extent, to an infinite distance) is in a peculiar condition. If a magnet be laid under a piece of glass and soft iron filings be sprinkled on the glass, each filing will assume a particular direction; and the whole congeries will map out the lines of the directions in which small magnets will be made to point by the play of the magnetic forces existing around the magnet, in the magnetic field of that magnet.

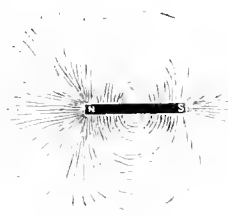

Fig. 4.

These directions are the Lines of Force in the magnetic field filling all space; and an example of them is given in fig. 4, which shows the arrangement of the filings above a bar magnet, laid parallel to the glass. In a horseshoe magnet the strongest part of the field extends to the magnet is that lying between the poles; the lines of force are there crowded together.

Magnetic Induction.—These lines of force external to the magnet are also Lines of Induction. In the direction of the lines of induction a magnetic separation tends to be set up; the soft iron filings are each converted, while in the neighbourhood of the magnet, into temporary magnets, each with a north and a south pole; the one pole is repelled, the other attracted; on the whole each filing is swivelled round into the direction of the local line of force. Similarly, a bar of soft iron becomes, while in contact with a magnet, as in fig. 5, or to a



Fig. 5.

less extent when in its neighbourhood, itself a temporary magnet; and it may in its turn magnetise and support other bars, so that a chain of soft iron bars may, up to a limiting weight, be supported on a magnet. Steel bars are slower than soft iron in taking up a magnetic condition, and the harder their temper the slower they are in doing so; but, unlike soft iron, they do not readily lose what they have acquired; they become permanent magnets, while soft iron retains magnetism only precariously and easily loses it when mechanically disturbed. Specially soft iron may lose the whole when struck; ordinary wrought-iron will generally retain traces of residual magnetism, the amount of which depends on the previous magnetic history of the particular bar. The characteristically magnetic substances are iron, nickel, and cobalt; but many others, even liquids (such as solutions of salts of iron) and gases (such as ozone), are attracted by the magnet.

Diamagnetism. Most substances are (in the form of spheres) feebly repelled by magnets, and bars of them lie across the lines of induction in a non uniform magnetic field. These substances are said to be diamagnetic, e.g. bismuth.

Magnetisation by the Earth. The inductive action

of terrestrial magnetism is a striking proof of the truth of the theory already referred to, that the earth itself is a magnet. When a steel rod is held in a position parallel to the Dipping-needle (q.v.) it becomes in the course of time, and the sooner if struck with a hammer, permanently magnetic. A bar of soft iron held in the same position is more powerfully but only temporarily affected. We may understand from this how the tools in workshops are generally magnetic. Whenever large masses of iron are stationary for any length of time they are sure to give evidence of magnetisation, and it is to the inductive action of the earth's poles acting through ages that the magnetism of the loadstone is probably to be attributed.

Preservation and Power of Magnets.—Even steel magnets, freshly magnetised, sometimes gradually fall off in strength, till they reach a point at which their strength remains constant. This is called the *point of saturation*. If a magnet has not been raised to this point it may lose nothing after magnetisation. We may ascertain whether a magnet is at saturation by magnetising it with a more powerful magnet, and seeing whether it retains more magnetism than before. The saturation-point depends on the material of the magnet itself. When a magnet is above saturation it is soon reduced to it by repeatedly drawing away the armature from it. After reaching this point magnets will keep the same strength for years together, if not subjected to rough usage. It is favourable for the preservation of magnets that they be provided with an armature or keeper. The power of a horseshoe magnet is usually tested by the weight its armature can bear without breaking away from the magnet. Small magnets are much stronger for their size than large ones. The reason of this may be thus explained. Two magnets of the same size and power, acting separately, support twice the weight that one of them does; but if the two be joined, so as to form one magnet, they do not sustain the double, for the two magnets, being in close proximity, act inductively on each other. The north pole of the one tends to repel the adjacent magnetism of the contiguous north pole of the other, and to form by induction a south pole in its place; the magnets thus weaken one another. Similarly, several magnets made up into a battery have not a force proportionate to their number. Large magnets, in the same way, may be considered as made up of several laminae, whose mutual interference renders the action of the whole very much less than the sum of the powers of each. The best method of ascertaining the strength of bar-magnets is to cause a magnetic needle to oscillate at a given distance from one of their poles, the axis of the needle and the pole of the magnet being in the magnetic meridian. These oscillations observe the law of pendulum motion, so that the force tending to bring the needle to rest is proportionate to the square of the number of oscillations in a stated time.

Action of Magnets on each other.—Coulomb discovered, by the oscillation of the magnetic needle in the presence of magnets in the way just described, that *when magnets are so placed that two adjoining poles may act on each other without the interference of the opposite poles* i.e. when the magnets are large compared with the distance between their centres *the attractive or repulsive force between two magnetic poles varies inversely as the square of the distance between them*. Gauss proved from this theoretically, and exhibited experimentally, that when the distance between the centres of two magnets is large compared with the size of the magnets i.e. when the action of both poles comes into play *the action of two magnets on each other varies inversely as the cube of the distance between*

them. This variation in the strength of the field may be shown either by the oscillation experiments above referred to, or by direct observation of deflections produced at different distances. The action on a magnet in a uniform magnetic field is that of a couple, like that of the hands on a copying-press. There is rotation, but no translation, unless the field falls off in strength from the position of the one pole to that of the other.

Effect of Heat on Magnets.—When a magnet is heated to redness it loses permanently every trace of magnetism; iron, also, at a red heat, ceases to be attracted by the magnet. At temperatures below red heat the magnet parts with some of its power, the loss increasing with the temperature. The temperatures at which other substances affected by the magnet lose their magnetism differ from that of iron. Cobalt remains magnetic at the highest temperatures, and nickel loses this property at 662° F.

Electric Relations of Magnetism.—Every electric circuit is a closed loop of some form or other. Every such loop bearing a current has round it a magnetic field; and such a single loop is equivalent to a thin disc, or shell of any form, cut out of a large bar-magnet, and has a south and a north aspect. The lines of induction pass, say, from the north face outwards, filling all space, and return to the south face, threading the loop, so that each line



Fig. 6.

of induction is a closed curve. The lines of induction immediately surrounding the wire are, if the circuit be large enough, circular in form. If wire bearing a current be coiled into a helix or solenoid (left-handed, fig. 6; right-handed, fig. 7), the helix



Fig. 7.

acts in respect to bodies external to it exactly in all respects as a bar-magnet would do: the strength of the equivalent magnet being in proportion to the strength of the current passing. The magnetic field surrounding a current-bearing loop or helix is called an *Electro-magnetic Field*; and it is identical with the field which might be produced by a sufficiently magnetised mass of the same contour: the difference being that, since currents may be made very strong, 'electro-magnetic' fields can be made more intense than any magnetic fields obtainable from steel magnets. These phenomena have led up to Ampere's theory of magnetism.

Ampere's Theory of Magnetism.—Ampere considers that every particle of a magnet has closed

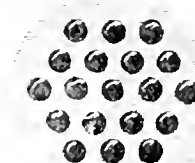

Fig. 8.



Fig. 9.

currents circulating about it in the same direction. A section of a magnet according to this theory is

shown in fig. 8. All the separate currents in the various particles may, however, be considered to be equivalent to one strong current circulating round the whole (fig. 9). Before magnetisation the molecules lie in different directions, so that the effect of the currents is lost, and the effect of induction is to twist the molecules round so as to bring the currents to run in the same direction. The perfection of magnetisation would be to render all the various currents parallel to each other. Soft iron, in consequence of its offering less resistance to such a disposition, becomes more powerfully magnetic under induction than steel, in which considerable resistance to this displacement of the molecules exists, and which, when this deformation has once been produced, retains it to a considerable extent, this being the cause of permanent magnetism. This displacement of the molecules upon induction is often accompanied by a tick, or by a mechanical twist or an alteration in length and thickness.

Currents may also, it is probable, be induced by a magnetic field in the several molecules of a substance non-magnetic or not; and, as these are so directed as to oppose the magnetic field, we will, if we postulate the absence of resistance to them, arrive in non-magnetic substances at a state of things in which the stresses in the magnetic field and those in the substance acted upon by induction are opposed; and this will give rise to the phenomena, and may provide an explanation, of diamagnetism, which is, so far as is known, a property of bodies only found manifested within a magnetic field.

Magnetic Induction inside a Helix.—The interior of a current-bearing helix is a very powerful magnetic field, the most powerful part of the whole electro-magnetic field of the helix, since all the lines of induction are concentrated within it. Soft iron then becomes, instantly on the passage of a powerful temporary magnet, or 'electro-magnet,' as it is called, which falls off in power instantly on the current being stopped; steel becomes permanently magnetised. Fig. 10 shows

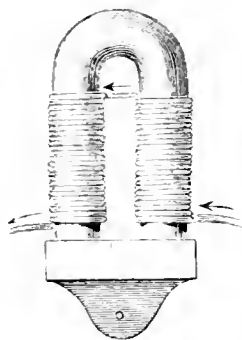

Fig. 10.

how the wires may be arranged to magnetise a horseshoe-bar.

The current of the helix, acting on the individual currents within the molecules, places them parallel to itself, and the result is that the soft iron comes to act as a magnet, stronger than any steel magnet. So long as the process of setting the molecules in position is far from being completed, i.e. so long as the iron is not 'saturated'—the strength of the magnetism induced in the core is approximately in proportion to the strength of the current and the number of turns in the coil. Another result is that on introducing a soft iron core into a current-bearing helix the lines of induction, which are due to the induced current of the soft iron molecular currents, are added to those of the inducing field, so that the whole field is greatly strengthened.

Magnetic Attractions and Repulsions of Currents.—The stresses in the magnetic field are such as to make all lines of induction from various sources coincide as far as possible in direction; and hence circuits tend to place themselves, as far as possible, coincident with one another in respect of form and parallelism of current. It is not difficult

to show that this tendency results in movements the same as those which would be produced if linear currents in the same direction (parallel, convergent, or divergent) mutually attracted one another, and currents in opposite directions repelled one another. When a circuit is in part flexible, the flexible part being a wire or even merely a line of discharge through air, it tends either to expand or to contract in area, so that it may come, as near as may be, to meet these conditions; and the result is that similarly directed currents or parts

of the same current move into the closest possible proximity to one another. This is illustrated by fig. 11, in which the course of the current is shown by arrows; the movable part of the circuit, poised on mercury cups, will rotate in a magnetic field so as to tend to make the direction of its own lines of induction coincide with the direction of the lines of induction of the magnetic or electro-magnetic field, and thus to make its own contour embrace as many as possible of the lines of induction of the field, if their general trend coincide with its own, or as few as possible if they be opposed; and, consequently, if a wire in which a current passes downwards be placed vertically near *ed*, the lines of induction round that wire and those round *ed* coincide in general direction, and *ed* appears to be attracted by the wire; while if the current pass upwards *ed* is repelled, and *ef* attracted. Place, now, the wire below and parallel to *de*. If the current passes in the direction *d* to *e* no change takes place, as the attraction cannot show itself; but if the current moves from *e* to *d* the whole turns round till *d* stands where *e* was, and both currents run the same way. If the wire be placed at right angles to *de*, the rectangle turns round and comes to rest when both currents are parallel and in the same direction.

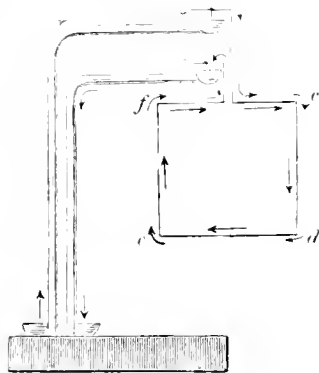

Fig. 11.

According to Ampère's theory, the earth, being a magnet, has currents in it which are equivalent to currents circulating about it; these must be from east to west, the north pole of the earth being, in our way of speaking, a south pole. A magnet, then, will not come to rest till its own lower currents place themselves parallel to and in the direction of the earth's currents. This is shown in fig. 12, where a section of a rectangular bar-magnet is represented in its position of rest with reference to the earth current. The upper current, being farther away from the earth current, is less affected by it, and it is the lower current that determines the position. A magnetic needle, therefore, turns towards the north to allow the currents moving below it to place themselves parallel to the earth's current. This also is shown by the current-bearing rectangle in fig. 11, which comes to rest in

how the wires may be arranged to magnetise a horseshoe-bar.

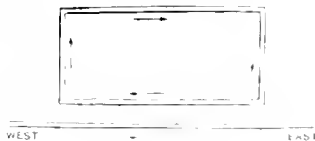

Fig. 12.

to show that this tendency results in movements the same as those which would be produced if linear currents in the same direction (parallel, convergent, or divergent) mutually attracted one another, and currents in opposite directions repelled one another. When a circuit is in part flexible, the flexible part being a wire or even merely a line of discharge through air, it tends either to expand or to contract in area, so that it may come, as near as may be, to meet these conditions; and the result is that similarly directed currents or parts

stable equilibrium, in the absence of any external current, when d and e lie east and west.

The Measurement of Magnetic Data. This has largely had its terminology evolved with reference to the equivalence of magnetic forces and phenomena to those which would be evinced if 'magnetism' were a kind of matter, positively or negatively attracting and resident in the poles. A *pole of unit strength* is one which attracts or repels another equal pole, situated at a distance of one centimetre, with a force of one dyne. The *magnetic moment* of a magnet is the strength of either pole multiplied by the distance between the two poles. This can be measured directly. The *intensity of magnetisation* of a bar magnet is the magnetic moment divided by its volume. A *magnetic field of unit strength or intensity* at any particular point is a field in which at that point a unit pole would be pulled upon or repelled with a force of one dyne; and conversely, the intensity of a uniform magnetic field may be measured by finding the mechanical couple acting on a magnetic needle, freely suspended in it. The intensity of induced magnetisation produced by putting a long bar of a magnetisable substance in a uniform magnetic field of unit strength measures the *magnetic susceptibility* of that substance. The force within the substance of an induced magnet, due both to the inducing field and to the surrounding magnetised substance, when the inducing field is unity, measures the coefficient of magnetic induction or the *magnetic permeability* of the substance. The *strength of a magnetic disc or shell* is its magnetic moment per unit of area, if this be uniform.

Magnetic Measurement of Electric Data.—Given a magnetic shell of given outline and strength, its action upon a magnetic needle placed within its field can be observed; and conversely, from its outline and its deflecting action its strength can be calculated. An electric current of the same contour can have its intensity so regulated as to produce the same magnetic effect as the magnetic shell did upon the needle in one position; and if in one, then in every position; and the intensity of that current is said to be, in magnetic measure, numerically the same as the magnetic strength of the equivalent magnetic shell. This is the basis of a system of electric units, called magnetic or electro-magnetic units of electric quantities; and convenient multiples and submultiples of these arrived at by substituting for the centimetre, the gramme, and the second, as the units of length, mass, and time, 1,000,000,000 cm., the $\frac{1}{1000}$ th part of a gramme and the second as these fundamental units are in use as the practical units for electrical measurement. These are the *ampere*, the unit of current intensity; the *ohm*, that of resistance (= the resistance of about 106.2 cm. pure mercury column, 1 sq. mm. in transverse section; defined as that of 106 cm. by the Paris International Electrical Congress); the *volt*, that of potential difference or 'electromotive force' (= approximately that of a Daniell cell, in which the liquids are a saturated solution of nitrate of copper and dilute sulphuric acid, 1 acid to 22 water); the *coulomb*, that of electric quantity; the *farad*, that of capacity; and the *quadrant*, that of self-induction.

Self-induction. When a current is suddenly started in a coil of wire, the ultimate result is to set up a magnetic field. But, while this is being set up, energy is being absorbed by the field, and the current falls short of its full intensity. Similarly, when the current ceases this energy is restored, and the current seems piled up as if it had momentum of its own like water in a hydraulic ram. The stronger the magnetic field that will be produced the more lines of induction will thread

the coil—the more marked is this effect; and this exaggeration is brought about by multiplying the turns in the coil (keeping down the resistance, if necessary, by increasing the thickness of the wire used), or by inserting a core of soft iron, or both.

Induction of Currents in Magnetic Field.—Lay two circuits in one another's neighbourhood. The sudden production or increase of current in the one will produce a brief current in the other in such a sense that there is mechanical repulsion between the induced current and the originating one; the cessation or diminution of the primary current induces, in the opposite sense, a brief current in the secondary circuit. These are phenomena of the magnetic field of the primary circuit; and the primary circuit can be replaced by a magnet or electro-magnet, whose approach or strengthening induces brief currents in one sense, and whose recession or weakening induces brief currents in the opposite sense. No current passes in the secondary coil so long as the primary current or magnet remains constant or stationary. For the ways in which this production of a secondary current is utilised, see DYNAMO, INDUCTION. If we try to move a good conductor—a copper disc or a knife—in a strong magnetic field the motion is resisted or damped; the production of the induced currents generated by motion in the field absorbs energy.

Rotatory Features of Magnetism.—As a simple case, consider the field in the immediate neighbourhood of a linear current. The lines of magnetic force run in circles round the wire; a magnet pole tends to be driven in such a sense that, if it be positive or north-seeking, it will travel round an advancing current in the same sense in which the point of a corkscrew travels round the axis of the advancing corkscrew. If a magnet were flexible it would form a coil round the current; and conversely, a flexible current bearing wire tends to coil round a strong bar-magnet, and currents parallel to bar-magnets tend to rotate round the magnetic axis of the magnet.

Nature of the Magnetic Field.—All the phenomena of the magnetic field are explicable as due to whirlpool currents of electricity in closed vortex-rings, the axes of which are the magnetic lines of induction. The reaction of tendencies to the formation of these vortex-rings from different sources results in the production of local variations of stress in the ether which result in attractive and repellent movements between currents or magnets, or between currents and magnets, or in the production of currents, or of magnetic induction; and the resultant forces are along the axes of the whirls which tend to shorten themselves longitudinally and to spread out laterally. The electric displacements in the whirls are therefore at right angles to the lines of magnetic force. With other dispositions of the magnetic field we have other forms of the lines of force; but they are always closed curves which mark the axes of vortex motions or shears, and which lie wholly in air, or partly in air and partly in metal or other substance.

Electro-magnetic Propagation. When a disturbance is set up in one place which leads to the formation of a magnetic field, the change from the original condition of the ether to the complex condition which is known as 'magnetic field' is marked by a magnetic or *electro-magnetic propagation* of the disturbance; and the theoretical velocity of this propagation has been shown to be about 300,000 kilometres per second, which is practically exactly the same as the speed of the propagation of light. In a linear current the direction of the current is the direction of propagation; the disturbance is propagated in the ether, not in the conductor; and the magnetic and electric displace-

ments are at right angles both to the direction of propagation and to one another. Without a linear conductor to guide the propagation the disturbance is propagated equally in all directions; and Clerk-Maxwell advanced the proposition that light is a phenomenon of this order, an electro-magnetic phenomenon involving vortical stresses, rather than the mere vibration of an elastic ether. This proposition has been strikingly confirmed by the researches of Hertz in 1888. He found that by producing waves of electro-magnetic propagation of periodic disturbances he could reproduce with long waves, which he found to travel at the predicted rate, the phenomena of reflection at the surface of a conductor, refraction, polarisation, interference, &c., which are manifested by those short and frequent ether-waves which give rise to the phenomena of light and radiant heat; and his results have shown that the plane of magnetic disturbance, at right angles to that of electric disturbance, is the analogue of the plane of polarisation, which must be at right angles to the plane of vibration. By Hertz's researches the science of light has been made a part of the general science of electro-magnetism.

See DECLINATION NEEDLE, DIAMAGNETISM, DIPPING-NEEDLE, DYNAMO-ELECTRIC MACHINES. For literature, see ELECTRICITY; and refer to Sir William Thomson's *Reprint of Papers on Electrostatics and Magnetism* (1872); Von Helmholtz's *Wissenschaftliche Abhandlungen* (vol. i. 1882); and O. J. Lodge, *Modern Views of Electricity* (1889). For instruments, &c., refer to W. E. Ayrton's *Practical Electricity* (1886) and Jamieson's *Magnetism and Electricity* (1890).

Magnetism, ANIMAL. See ANIMAL MAGNETISM and HYPNOTISM.

Magnetism, TERRESTRIAL. Under the general article MAGNETISM the broad fact that

the earth is a magnet has been incidentally touched upon. In this article we propose to consider in more detail the magnetic features of the earth as a whole. In studying the magnetic field associated with the earth we are confined to its surface, and are unable to trace the lines of force throughout their whole length. We believe, however, that these lines of force have the properties of all lines of force associated with magnets. In general they pass by continuously curved paths from regions in the southern hemisphere to regions in the northern hemisphere. The southern hemisphere, therefore, is the seat of what is called northern or positive magnetism.

The direction of the line of force at any point is given by the direction in which a perfectly free magnet placed there will point (see MAGNETISM). To obtain the direction of the earth's magnetic force we must suspend the magnet accurately by its centre of mass, as in the apparatus known as the Dipping-needle (q.v.). With such an apparatus, let us, beginning at the extreme south point of Africa, move northwards and study at each successive stage the behaviour of the magnet. At first it will be found to make an angle of about 57° with the horizontal, pointing upwards towards the north-west. This angle of 57° is called the dip, and will steadily diminish as we pass northwards, until, a little to the south-east of Lake Chad, the magnet will be found to rest perfectly horizontal. Proceeding still northwards, we shall find the magnet beginning to tilt again, but this time with the north-pointing end downwards. As we leave the north coast of Africa in 20° E. long. the dip will be nearly 45°; it will be 55° as we enter Turkey, gradually increasing to nearly 77° as we leave the north coast of Norway. Very similar changes in dip will occur as we pass along any

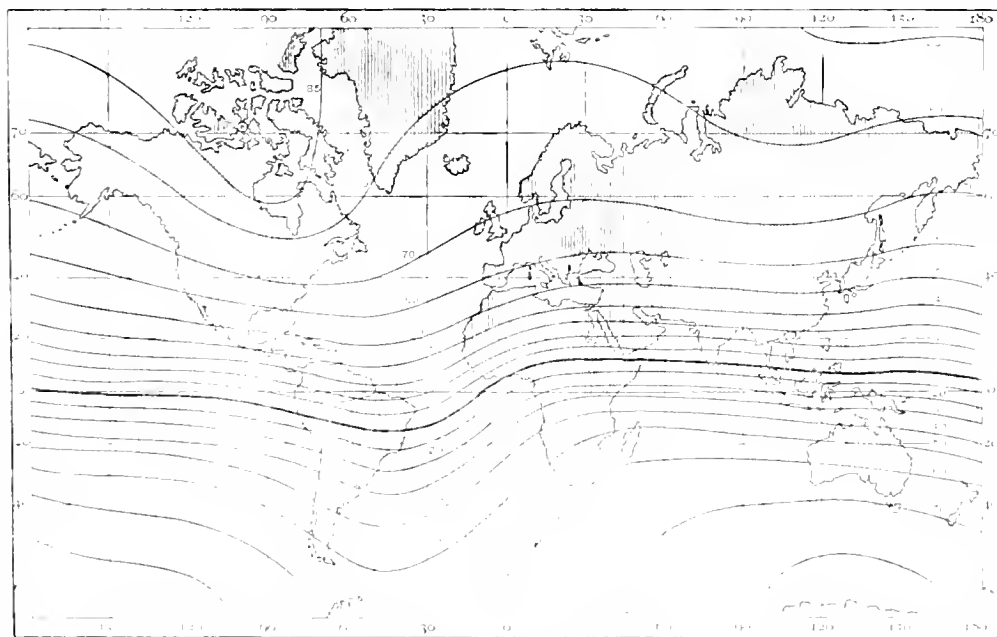

Fig. 1.—Lines of equal Magn. Dip. 1887.

longitude line. The general features are shown in fig. 1, reduced from Neumayer's chart for 1885, as given in the new edition of Berghaus' *Physikalischer Atlas*. Each line is drawn through all places at which the dip has the value indicated by the number attached. The only points requiring

particular remark are the position of the line of zero dip, and the position of the point of maximum dip. The line of zero dip is called the magnetic equator. Its non-coincidence with the geographical equator indicates a marked departure of the earth's magnetic condition from the magnetic condition of a

uniformly magnetised sphere, whose magnetic axis coincides with the polar axis. The position of maximum dip shown is where the needle points vertical with its north end downwards. It is called the magnetic north pole, and is situated in the north of Canada in 97° W. long., and 70½° N. lat. There is also a magnetic south pole, which is believed to lie somewhere near 150° E. long. and 73° S. lat. The magnetic poles do not, therefore, lie exactly at the extremities of a diameter. It should be noted that the dip is the angle between the line of force at a given locality and the horizontal plane there; that is, the dips in different latitudes are referred to different planes. Fig. 2, which represents the section of the earth along the great circle passing through the geographical and magnetic north poles, will serve to indicate the approximate relative positions of the lines of force. The directions of these at latitudes 0°, 30°, and 60° are indicated by arrows, the dotted

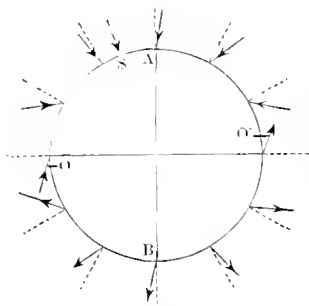

Fig. 2.

lines giving the directions of the true vertical at the various points. AB is the geographical polar axis, S the 'magnetic north pole'—really analogous to the so-called south pole of a magnet.

00° are the points of zero dip, where the lines of force will be roughly parallel to the magnetic axis.

Returning again to the southern extremity of Africa, let us consider more fully the position of the magnet hanging freely by its centre of mass. To fix this position we require to know not only the dip but also the geographical lie of the vertical plane in which the magnet hangs. This is given by the Declination (q.v.), which may be defined as the angle between the meridian plane and the vertical plane parallel to the magnetic axis of the free-hanging magnet. Practically this angle is determined by a magnet suspended or pivoted so as to lie horizontally, and is what every mariner's compass gives more or less accurately. Near Capetown the declination is fully 30° west of north (NNW½W.); but as we pass northwards it gradually diminishes, until on the Mediterranean shore in 20° long. it becomes only 8° west of north (N½W.). Passing farther north we find it still diminishing, but more slowly, until finally, as we leave the north coast of Norway in the same longitude, it is found to be 6° (N½W.). The general features of the declination are shown in fig. 3. Each isogone or line of equal declination passes through localities at which the declination had the value as marked in 1885. This figure is also reduced from Neumayer's chart. It will be seen at a glance that the surface of the globe is divided broadly into two regions, separated by the agonic lines (marked thick) or lines of no declination. The one region, including the Atlantic with the whole of Africa and a large part of the Indian Ocean, is characterised by a westerly declination; and the other (with an interesting exception) an easterly declination. These are indicated by arrow-heads appropriately directed.

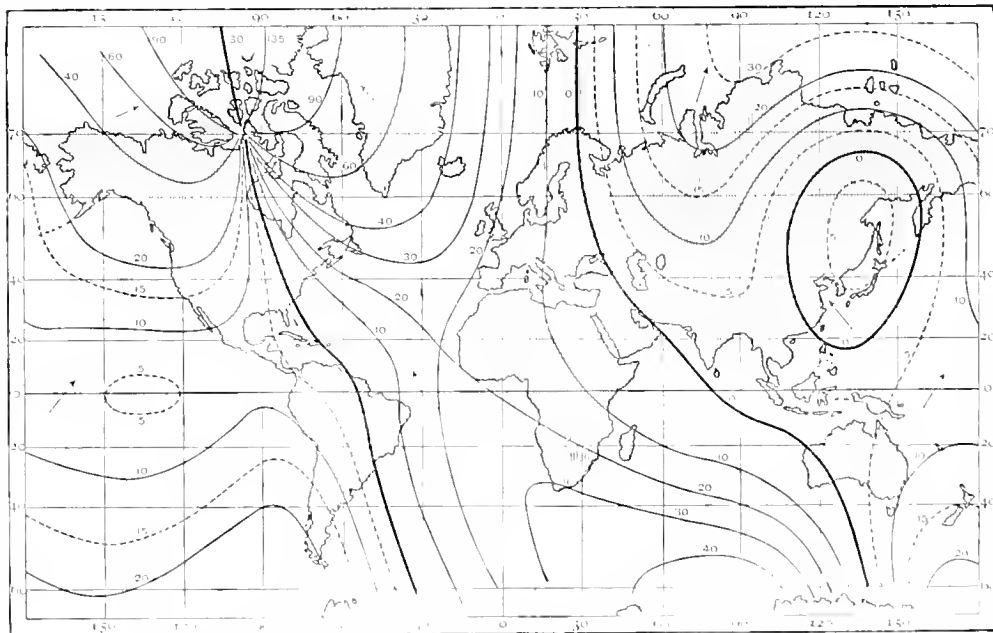

Fig. 3.—Lines of equal Magnetic Declination, 1885.

The western boundary of the region of westerly declination passes through the magnetic north pole. This line passes through the localities where the magnet points true geographical north. It continues itself northwards towards the geographical pole as the isogone of 180°, since any magnet, set between the magnetic pole and the geo-

graphical pole, will turn its marked end towards the south instead of towards the north. The eastern boundary of western declination passes northwards from Europe till, at the geographical north pole, it meets the short isogone of 180° just mentioned. After its south-easterly sweep across the Indian Ocean this line of zero declination

passes through the western portion of Australia and finally ends at the 'magnetic south pole.' Continuing as the isogone of 180° till it reaches the geographical south pole, it joins with the other boundary line of zero declination. It will be readily seen that the region of western declination is more contracted than the other; but, as if to balance this, there is an isolated region of western declination situated in the midst of the region of eastern declination. This isolated region lies on the east of Asia, and is enclosed in an oval-shaped agonic line (marked with a thick line in the chart). Declination charts for all seas and shores are invaluable to the practical navigator, by whom they are called variation charts. From them he learns at a glance in what direction the magnetic needle points at the place he happens to be in, and can steer his desired course accordingly. For example, in a voyage from England to India by way of Suez, the western declination diminishes rapidly from 17° at Gibraltar to 5° at Suez. Before India is sighted the agonic line is crossed, and the declination becomes slightly easterly. Thereafter,

on as far as Hong-kong or Torres Strait, the compass points never so much as half a point to the east of north. Hong-kong is just outside the small isolated region of westerly declination, through which the route to Vancouver passes. As Vancouver is approached, however, the easterly declination rapidly increases to nearly 25°.

The declination and dip completely determine the direction of the line of force. Its strength or intensity still requires to be known before the magnetic conditions are completely fixed. The total force we may imagine to be determined by measuring the time of oscillation of a dipping-needle of known magnetic moment. Practically, however, it is easier and much more accurate to measure the horizontal component of the total force or intensity of the field. It is consequently more useful to construct a chart showing lines of equal 'Horizontal Force.' Such a chart is shown in fig. 4 (also from Neumayer's chart), each line being drawn through localities at which the horizontal force has the value as marked. The horizontal force must, of course, vanish at the

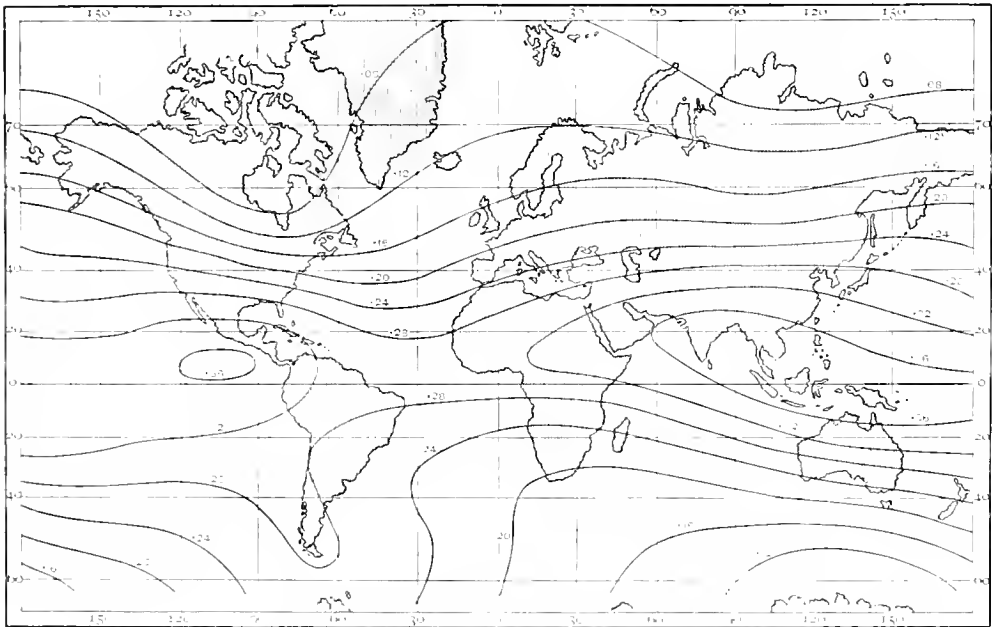

Fig 4.—Lines of equal Horizontal Force, 1855.

magnetic poles, which we originally defined as the regions where the dip was 90°. From figs. 1 and 4 taken together we may calculate roughly the total magnetic force at any locality, by multiplying the horizontal component by the secant of the angle of dip. Thus, for Edinburgh we have, roughly, $0.165 \times 3 = 0.49$; in Hudson Bay, $0.08 \times 9.5 = 0.76$; in Central Africa, where the magnetic equator cuts the 20° longitude line, $0.33 \times 1 = 0.33$. The total force, therefore, increases in a general way as we approach the magnetic poles. Its maximum values, however, are not exactly at these poles, nor do the positions of minimum value lie on the line of dip.

The declination, dip, and horizontal force are commonly called the magnetic elements. They are all subject to variations in time, so that magnetic charts for one epoch will differ somewhat from those for another epoch. For example, comparing the isogonic lines given in fig. 3 with the isogonic lines for 1810, we see that both the long agonic

lines have, for the greater part of their lengths, moved westwards, and the agonic oval has changed form slightly and moved a little eastwards. A line drawn from Nova Scotia to the Cape of Good Hope divides the Atlantic into two regions. In the north-eastern region the declination has been diminishing during the last twenty years, while in the south-western the declination has been increasing. There is some evidence of a periodic variation extending over several centuries. Thus, in 1600 the agonic passed to the west of England and through the Cape of Good Hope, the declination in England being about 8° east of north. In 1700 the westerly declination in England had become 6° or 7°, and that at the Cape about 12°. In 1800 the declinations had increased to 23° or 24° at the two places. All this indicates an eastward motion of the line of zero declination. Since 1818 the westerly declination in England and in western Europe generally has been slowly diminishing, showing that the agonic

line had ceased its easterly and begun its present westerly drift. In the charts published by the United States Coast and Geodetic Survey very full information is given regarding the westerly drift of the agonic line that passes through America. South of the Great Lakes its average rate of progress during the last forty years has been nearly five miles per annum. In 1890 the annual change of declination at places in the neighbourhood of the agonic line was about three minutes of arc, westerly increase. At Greenwich the present annual change is about seven minutes of arc, westerly decrease. The secular changes in the dip and horizontal force are very slight, and generally take place in opposite directions, so that the change in the total intensity is still smaller.

The solar diurnal variation of the magnetic elements, and especially of the declination, is the most easily recognised of all the periodic variations to which the earth's magnetism is subject. In all but tropical regions the declination needle oscillates markedly about its mean position for the day, attaining its maximum deviation from one to two hours after noon. In the northern hemisphere this maximum deviation is to the west of the mean position; in the southern hemisphere it is to the east. Again, the total range of variation is greater in the summer months than in the winter months. By an elegant development of Gauss's lawless theory of terrestrial magnetism Schuster has shown that the features of the solar diurnal variations of the different magnetic elements indicate causes above the earth's surface as the source of these variations. This accords with Balfour Stewart's hypothesis that the diurnal magnetic changes result from electric currents in the higher regions of the atmosphere. These currents are due to the action of the sun, and are probably associated with the currents of hot air which pass from the equatorial regions both northwards and southwards. That such electric currents do really exist is demonstrated by the existence of the aurora in higher latitudes; for this phenomenon is beyond question electrical. Further, distinct connection has been traced between auroral displays and magnetic disturbances of exceptional character (see AURORA BOREALIS). These irregular magnetic disturbances or magnetic storms, as they are called, are more frequent and more pronounced at times of maximum sun spots; and, according to Loomis, a great magnetic storm is always accompanied by an unusual disturbance on the sun's surface. Again, there is no doubt some connection between certain types of magnetic changes and earth-currents, the latter being particularly strong during magnetic storms; but it is now admitted by all authorities that earth-currents cannot be regarded as an efficient cause of the magnetic disturbances.

In addition to the well-marked solar-diurnal variation of the magnetic elements, there is also a lunar-diurnal variation, which has been specially studied by Broun and Chambers. These and other phenomena of terrestrial magnetism show that the earth is magnetically sensitive to cosmic influences. These influences may be directly magnetic; or, as is more probable in the case of the solar-diurnal variations, they may give rise to meteorological changes involving electric and magnetic actions. As to the ultimate origin of the earth's magnetism as a whole it is not possible, in the present state of the science, to formulate any satisfactory hypothesis. The rotation of the earth, which is so important a factor in the broad meteorological features that exist over the earth's surface, is the only dynamic polarity that can be compared to the magnetic polarity. According to the nebular hypothesis the earth's rotation is a

part of a grand circulatory motion of the solar system. So may the earth's magnetism be a part of the general magnetic conditions of the same system. If such a view is too vague for acceptance, the only hypothesis which seems to meet the case is that suggested by Balfour Stewart, who traces the magnetic condition of the earth to the terrestrial meteorological system, as modified by the earth's rotation, acting cumulatively through the ages.

Magnetite. See LOADSTONE.

Magneto-electric Machine. See DYNAMO-ELECTRIC MACHINES.

Magnetometer is, in general, any instrument for measuring magnetic force, or for comparing one magnetic force with another. A freely-suspended magnet, whereby the strength and direction of the lines of force in a magnetic field may be ascertained by observing the position assumed by a freely-suspended magnet and also its rate of oscillation and the amount to which it is deflected when under the influence of a second magnet, is the essential feature of all magnetometric instruments. The peculiar importance to us of the earth's magnetic field has, however, led to the construction of instruments of precision, to which the name Magnetometer is specially applied.

In a magnetic observatory the self-registering magnetometers or magnetographs form an extremely important set of instruments. By these the quick changes in the intensity of the earth's magnetic field and in the declination are registered by photographic means. The essential feature of the method is the reflection of a beam of light from a mirror attached to a magnet, which is suspended or pivoted so as to be sensitive to changes in the particular element that is being measured.

Magnificat, the 'song of the Virgin Mary,' which, in the Vulgate, begins with *Magnificat*. See BREVIARY.

Magnifying Glass. See LENSES, MICROSCOPE.

Magnolia, a genus of beautiful trees of the natural order Magnoliaceæ, having a calyx of three sepals, a corolla of six to twelve petals, and carpels in spikes arranged in cones, and opening at the dorsal suture. They are natives chiefly of North America, the Himalaya Mountains, China, and Japan. The flowers are large and solitary; the leaves generally large, in some species evergreen, in others deciduous. The wood is in general



Magnolia grandiflora.

soft, spongy, and of little value. *M. grandiflora*, sometimes called the Laurel-leaved Magnolia, has white flowers of great size. It is an evergreen tree about 20 feet high, with magnificent laurel-like

leaves, found in the lower districts from North Carolina to the Gulf of Mexico. It succeeds well as an ornamental tree in the south of England, but in Scotland requires a wall and some protection in winter. *M. tripetala* is found on the Alleghany Mountains, and extends as far north as lat. 43°. From the radiated manner in which its leaves are disposed at the extremities of the branches it has received the name of Umbrella Tree. It has very large white flowers. It is one of the species most commonly cultivated in Britain, but in Scotland it requires a wall. *M. acuminata* inhabits the same districts, and is a lofty tree with greenish-yellow flowers. It endures the climate of Britain well, but its flowers are not so much admired as those of some of its congeners. *M. glauca*, a native of Pennsylvania, Virginia, and the Carolinas, is known by the names of *White Bay*, *Beaverwood*, and *St. John Sassafras*. It is a tree or shrub of 15 to 20 feet in height, with very beautiful and fragrant white flowers. The Yulan, or Chinese Magnolia (*M. Yulan* or *conspicua*), has been much cultivated in China for more than twelve hundred years on account of its beautiful and fragrant white flowers, which it produces in great profusion. It is one of the finest ornamental trees, and succeeds well in the south of England. It is a deciduous tree, and the flowers expand before the development of the leaves. *M. caroliniana*, one of the finest species known, is a predominant tree in some parts of the Himalaya Mountains, at an elevation of 7000 to 8000 feet, the mountains, when it is in blossom, appearing as if sprinkled with snow. *M. Campbellii*, another native of the same region, produces great rose-colored flowers, and is described by Hooker as the most superb of the genus. The bark and fruit of all magnolias possess tonic bitter properties, and the bark of some of the species, particularly that of *M. glauca*, is used in domestic medicine in the marshy districts of North America in cases of rheumatism and fever. *Michelia* and *Manglietia* are closely allied genera. The natural order Magnoliaceae is closely allied to Ranunculaceae, differing chiefly in the arborescent habit, and in the large stipules which envelop the young leaves before they open, but soon fall off. The leaves are simple. Aromatic properties are prevalent. To this order belong the Tulip Tree, Star Anise, and Winter's Bark.

Magnus, St., a Scandinavian Earl of Orkney who in 1114 was assassinated in Egilshay Island by his cousin Haco.

Magnus or **MAGNI**, **OLAFS**, Swedish historian, was born at Linköping in 1490, and became secretary to his elder brother Johannes, Archbishop of Upsala. At the Reformation both brothers went abroad, and ultimately settled in Rome. On the death of Johannes, Olaf became titular archbishop, and died in 1558. Both brothers wrote on Swedish history; the famous work of Olaf is his *Historia de Gentibus Septentrionalibus* (1555).

Magpie, or **PIE** (*Pica*), a genus of birds of the family Corvidae (q. v.), distinguished from the true crows by their small size, long tail, short wings, and variegated plumage. The only British species is the Common Magpie (*P. rustica*), common in Britain, very abundant in Ireland, and found in almost all parts of Europe, in Asia as far as India, China, and Japan, and in the northern parts of North America from the Pacific to Michigan. It is from 16 to 18 inches long, the longest tail-feathers sometimes measuring 11 inches in length. It is of a glossy black plumage, slightly greenish and violet on the crown and back, with a slightly coppery tinge on the head; rump gray; shoulder-feathers and under surface of body white; wings and tail blue, green, and white; bill, legs, and feet

black. The female is slightly smaller than the male and less brilliant in plumage. The magpie is a shy, mischievous bird, extremely vigilant and cunning, both in eluding enemies and in seeking its own food. It is generally seen in pairs, but

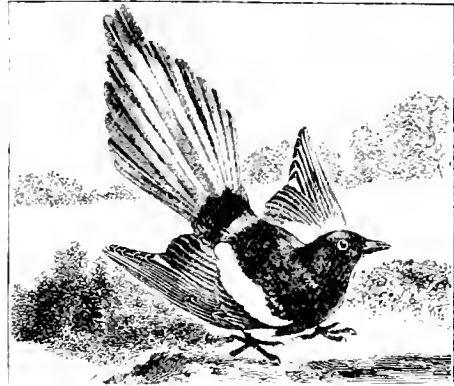

Common Magpie (*Pica rustica*).

occasionally in large flocks. Its note is a harsh chatter, kept up as long as any obnoxious person or animal is near its haunts. In diet it is almost omnivorous, living on snails, slugs, worms, frogs, rats, mice, and the eggs and young of poultry. It builds its nest usually in the fork of a tree at some distance from the ground, but sometimes on low hedges and thorn bushes, or even on the ground. In Norway and Sweden, where it is favoured, it may be found nesting near houses on low goose-berry bushes. Its nest is large and dome-shaped, made of sticks cemented with clay and lined with fine roots and dried grass. It is strongly fortified with rough thorns, so as to resist the attacks of other animals, and even the action of the small shot which gamekeepers fire into it when they suspect it to contain young birds. The eggs are from six to nine in number, of a pale bluish green or yellowish-white, spotted with olive-brown. The mother shows great attachment to her progeny. The magpie is easily tamed, becomes impudently familiar, and learns to articulate a few words. Both in its wild and tame state it has a propensity to seize and carry off bright and glittering articles and hide them. The genus *Pica* consists of nine species, very widely distributed in Europe, Northern Africa, Asia north of the Himalayas, in Arctic America, and California.

A great wealth of popular superstition has clustered round the magpie or *pyot*, and almost universally it is considered as in a special sense a bird of evil omen. In Germany, Sweden, and Brittany it is closely connected with witches and with the devil, and it is unlucky to kill one, except during the twelve days between Christmas and Epiphany in Sweden and North Germany, and during the month of March in Thuringia. Popular reasons for the bird's persistent wickedness, in the north of England, are: because it was the only bird that would not go into the ark with Noah; because it is a hybrid between the raven and the dove; because after the crucifixion it alone of all the birds did not go into full mourning. Its appearance and the numbers seen at one time are always significant. There are many variants (some even contradictory), but the following is in good belief in the north of England:

One is sorrow, two is mirth,
Three a wedding, four a birth,
Five heaven, six hell,
Seven the devil's ain sel.

Wordsworth, in the *Excursion*, has alluded to the auspicious omen of seeing two magpies cross one's path, and Sir Humphry Davy, in *Salmonia*, has made it reasonable by linking the fact with the goodness of the weather.

Maguey. See AGAVE.

Magyars. See HUNGARY.

Mahabaleshwar, the chief sanatorium of the Madras Presidency, on the eastern slope of the Western Gháts, at a height of 4717 feet, and 74 miles S. of Poona. Pop. 3500.

Mahábhárata (meaning probably 'the great history of the descendants of Bharata') is the name of one of the two great epic poems of ancient India; the other being the *Rámáyana* (q.v.). In its present condition the epos consists of a hundred and ten thousand couplets, each containing thirty-two syllables; but there is ground for believing that it was formerly known in other recensions of a still greater extent. In its actual shape it is divided into eighteen parvans or books, the Harivansa being considered as a supplementary part of it. That this huge composition was not the work of one single individual, but a production of successive ages, is manifest from the multifariousness of its contents, from the differences in style, and even from the contradictions which disturb its harmony. Hindu tradition ascribes it to *Vyása*; but as *Vyása* means 'the distributor or arranger,' and as the same individual is also the reputed compiler of the Vedas, Puránas, and several other works, it is obvious that no historical value can be assigned to this generic name. The contents of the Mahábhárata may be distinguished into the leading story and the episodical matter connected with it. The former is probably founded on real events in the oldest history of India, though in the epic narrative it will be difficult to disentangle the reality from the fiction. The story comprises the contest of the celebrated families called the Kauravas and Pandavas, ending in the victory of the latter, and in the establishment of their rule over the northern part of India. Kurn, a descendant of Bharata, had two sons, Dhritarashtra and Pándu. Dhritarashtra's sons, the Kauravas, were a hundred in number; Pándu's, the Pandavas, only five. Pándu having resigned his throne, Dhritarashtra, though blind, assumed the government, and ultimately divided his kingdom between his sons and the sons of Pándu. The former, however, coveting the territory allotted to the Pándu princes, endeavoured to get possession of it. A game of dice was the means by which they bound over their cousins to relinquish their kingdom, promising, however, to restore it to them if they passed twelve years in the forests, and a thirteenth year in such disguises as to escape detection. This promise was faithfully kept by the Pándavas; but when the term of their banishment had expired the Kurn princes refused to redeem their word. A war ensued, ending in the complete destruction of the Kauravas. Duryodhana and his brothers are pictured as the type of all conceivable wickedness, and the Pándu princes as paragons of virtue and heroism, and the incarnations of sundry deities. Out of the hundred and ten thousand couplets which constitute the great epos barely a fourth part is taken up by this narrative; all the rest is episodical. The matter incidentally linked with the main story may be distributed under three principal heads: one comprising narratives relating to the ancient or mythical history of India, as, for instance, the episodes of Nala and Sakuntalá; a second is more strictly mythological, comprising cosmogony and theogony; a third is dialectic or dogmatic—it refers to law, religion, morals, and philosophy, as in the *Bhagavad-Gítá*,

for instance. By means of this episodical matter, which at various periods, and often without regard to consistency, was superadded to the original structure of the work, the Mahábhárata gradually became a collection of all that was needed to be known by an educated Hindu; in fact, it became the encyclopædia of India.

The text of the Mahábhárata was published in Calcutta in four quarto volumes (1834-39), another edition at Bombay in 1863, and another, under native Hindu auspices, at Calcutta in 1882 and succeeding years. The French translation by Fauche (10 vols. 1865-70) is incomplete; a complete English prose translation by Hindus, of which, up to 1890, 50 parts had appeared, was published and distributed, chiefly gratis, at Calcutta, under the auspices of Pratápachandra Roy. Many episodes, as the *Bhagavad-Gítá*, have been separately edited and translated. See Lassen's *Altertumskunde*; H. H. Wilson's works; Monier Williams, *Indian Epic Poetry* (1863); Wheeler, *The Vedic Period of the Mahábhárata* (1867).

Mahádeva ('the great god') is one of the usual names by which the Hindu god S'iva is called. See SIVA.

Mahánadí ('the great river'), a river of India, rises in the Central Provinces, in 20° 16' N. lat., 82° E. long. After an eastward course of 520 miles, 300 miles of which are navigable, having divided into several branches at or near the town of Cuttack, which forms the head of its delta, it flows east and south-east through the district of that name, and falls by several mouths into the Bay of Bengal. The catchment basin of the Mahánadí is less than 44,000 sq. m., yet its maximum discharge in time of flood equals that of the Ganges—1,800,000 cubic feet per second—and exceeds that of the Mississippi. An elaborate system of canals has been constructed to take advantage of this abundance.

Mahanoy' City, a mining town of Pennsylvania, 109 miles by rail NW. of Philadelphia, with a score of collieries and several manufactories. Pop. 7181.

Maharajah. See RAJAH.

Mahávausa, two celebrated works written in Páli, and relating to the history of Lanka, or Ceylon, from its earliest period down to the reign of Mahásena, who died 302 A.D. The first thirty-eight chapters were published in 1837 by G. Turnour; and there is an edition of the whole in Páli and Singhalese (Colombo, 1877-83).

Mahávíra (literally, 'the great hero') is the 24th or last Jina, or deified saint, of the Jains (q.v.). His legendary history is given in the *Kalpa-Sútra* and the *Mahávíra Charitra*, two works held in great authority by the Jains.

Mahdí (pass. part. of Arab *hadá* = 'he guided'; 'the well-directed one'), the Mohammedan restorer of all things. Though not mentioned in the Koran, he is said to have been promised by Mohammed to complete his work in filling the world as full of righteousness as it is of iniquity. The idea is that of the Jewish and Christian Messiah and of the Zoroastrian Saoshyant. Some need for reform soon made the idea practical. The first three califs were by Ali's party regarded as usurpers; and after Ali's reign and murder that party grew in number and in determination to recognise as Imám or calif none but Ali's heirs. Mohammed, a son of Ali though not of Fatima, but of 'the Hanafite,' bore unwillingly the name of Mahdí, and dying in peace he was expected to return. The Shia or party of Ali consisted mainly of Persians. This race opposed the Omniades because these were unprincipled men and half heathen, because they were their foreign tyrants, and because as usurpers they had broken through the divine right of heredity. The

Abbasides who, descended from the prophet's uncle, expelled and destroyed the Omniades by aid of the Shia were as much the enemies of these as their predecessors had been. The seventh Shiite Imam was poisoned by Haroun Abraschid the eighth by his temporarily Shiite successor Almanin; the ninth, tenth, eleventh followed the same path of martyrdom. The twelfth, Mohammed by name, disappeared after captivity at the age of twelve years in 879. The Shiite inference is that he, the 'hidden Imam,' will yet come as Mahdi to destroy the false prophet and, with the help of Jesus, to destroy or convert to Islam all mankind, and to put all wrongs right. Then will follow the resurrection and the final judgment. The native princes of Sofi's line who mastered the Persian throne in 1505 called themselves the lieutenants of the coming Mahdi. From the Isma'ilis (q.v.) in North Africa arose another Mahdi, from whom sprang the Fatimide califs. The seventh of these was Hakim, one of God's incarnations that had previously been Ali. He died, 'became hidden,' in 1020, and is expected by his sect the Druses. Among the Berbers of Mount Atlas in the 12th century arose another Mahdi, by name Mohammed ibn Tumert, whose disciple and successor Abdulmumin overran Morocco and supplanted the Almoravid dynasty there and afterwards in Spain. Hence the Almohade ('Unitarian') dynasty. The year 1666 produced in Turkey its Jewish Messiah, Sabbatai Zevi, and in consequence its Kurdish Mahdi for the suppression of this Dejjal, or false prophet. Both fell quietly into the sultan's hands. In 1799 another Mahdi arose in Egypt, against the French, and fell in battle. In Dongola, towards 1843, was born Mohammed Ahmed. He was for a time in the Egyptian civil service, but disagreeing with the governor, he became a trader and a leading slave-dealer. About the prophetic age of forty he claimed to be the Mahdi. Gradually at the Mahdi's call—the Muslim equivalent for a revolutionary spirit—the Eastern Soudan stirred itself against Egyptian misrule. In 1883 he seized El-Obeyd, the chief city of Kordofan, and made it his capital; and on the 5th November of that year the Egyptian army commanded by Hicks Pasha was annihilated. In 1885 Khartoum was taken by treachery, and General Gordon, whom Britain had sent to pacify the Soudan, was killed. The Mahdi died at Omdurman on 22d June 1885. The Khalifa Abdulla succeeded him, but never wielded his power, and his influence was destroyed by the British expedition to Dongola in 1896 and the disastrous defeats inflicted on him by the Sirdar Kitchener (afterwards Lord Kitchener) at the Atbara in April 1898, and especially at Omdurman on 2d September 1898. The Mahdi's tomb in Omdurman was destroyed, the Egyptian flag was hoisted at Khartoum, and, after Fashoda, the whole Nile Valley came under British influence.

For the rebellion, the defeat of Hicks Pasha, and the fall of Khartoum, see EGYPT (Vol. IV, p. 243), GORDON, SOUDAN. See also Darmesteter, *The Mahdi Past and Present* (Eng. trans. 1885); Wingate, *Mahdism and the Egyptian Soudan* (1891); Ohrwalder, *Ten Years' Captivity at the Mahdi's Camp* (1892); Slatin Pasha, *Fire and Sword in the Soudan* (trans. by Wingate, 1896); Bennett Barboz, *Sirdar and Khalifa* (1898); G. W. Stevens, *With Kitchener to Khartoum* (1898).

Mahé, the only French settlement on the west coast of India, is in Malabar district, 35 miles NNW. of Calicut. Area, 3½ sq. m.; pop. 8280.

Mahi Kantha Agency, a group of fifty two native states in Bombay. Of the total area of 11,019 sq. m. nearly one-half belongs to the state of Ekar. Pop. 581,868, including 30,000 Bhils.

Mahmud. See TURKEY, GRAZNI.

Mahogany, the wood of the *Swietenia mahogoni*, a tree from 80 to 100 feet high, belonging to the natural order Cedrelaceæ, a native of the West Indies and of South America. The tree attains an immense size, and its timber is generally found throughout in the largest trees. It is most abundant on the coast of Honduras and around Campeachy Bay. St Domingo and Cuba yield a finer quality than that obtained from the mainland, which is frequently called Bay Wood, to distinguish it from Cuba mahogany, usually called Spanish. The wood varies much in value, according to the colour and beauty of curl; single logs have occasionally realised as much as £1000, for cutting into veneers, in which state it is very generally used, its great weight and value unfitting it for being always employed solid. The first notice we have of mahogany is in connection with the repairing of some of Sir Walter Raleigh's ships in Trinidad in 1597; but the wood does not appear to have been carried to Britain till about the end of the 17th century, when it was brought from the West Indies as ballast by a Captain Gibbons. The captain's brother wished to use the timber for his house then in course of erection, but the workmen declined to work it owing to its extreme hardness. A portion was, however, given to one Wollaston, a cabinet-maker, of which to make a candle-box for Dr Gibbons. When finished, the box exhibited such rare beauty as to create much interest in society; and bureaux made by Wollaston soon established the reputation of mahogany for cabinet-work. The annual imports into Britain are about 40,000 tons, with a value of £350,000. The bark has a faint aromatic smell and a very astringent bitter taste, and in the countries where the tree grows is used as a medicine. As *Mahogany Bark*, or *Amaranth Bark*, it has been employed as a substitute for Peruvian Bark.—East India Mahogany is the timber of the *Rahuna Tree* (*Soyimida febrifuga*), and African Mahogany of the *Khaya Senegalensis*, both of the order Cedrelaceæ.

Mahomet. See MOHAMMED.

Mahon. See STANHOPE, PORT MAHON.

Mahony, FRANCIS, better known by his famous pen-name, 'Father Prout,' was born at Cork in 1804, and educated for the priesthood at a Jesuit college in Paris, and subsequently in Rome, where he remained for two years and received ordination. He taught in a Jesuit college, was chaplain to a Cork hospital, but ceased to exercise the clerical calling about 1834, and joined the staff of *Fraser's Magazine*, his contributions to which were republished under the title of *Reliques of Father Prout* in 1836. He contributed also to *Bentley's Magazine* from 1837. For two years he acted as Roman correspondent to the *Daily News*, and his letters were collected and published in 1847 as *Facts and Figures from Italy by Don Jeremy Sacumarolo, Benedictine Monk*. During the last years of his life he lived in Paris, and was correspondent to the *Globe* newspaper till his death, May 18, 1866. Mahony possessed great scholarship and a rich fund of genial humour. Amid all the convivialities of the 'Fraserians,' he preserved his reverence for religion without allowing it to cloud the brightness of his wit. 'His fun is essentially Irish—fanciful, playful, odd, irregular, and more grotesque than northern fun. In one of his own phrases, he is an Irish potato, seasoned with Attic salt, and oblivion has no poppy for the exquisite pathos of verse like 'The Bells of Shandon' and 'The Lady of Lee.' A volume of *Final Reliques of Father Prout* was published in 1876 by Mr Blanchard Jerrold; and there is an edition of his works, with a Life, by Charles Kent (1881).

Mahound, a corrupt early western spelling of MOHAMMED (q. v.).

Mahrattas (*Marāthas*, or *Marhatas*), a people of mixed origin, Hindus in religion and caste ordinances, inhabiting Western and Central India, from the Satpura Mountains to Nagpur. The Mahratta Brahmans claim to be Rajputs; the bulk of the people are Sudras, and probably of aboriginal blood mainly. They are first mentioned in history about the middle of the 17th century, when they possessed a narrow strip of territory on the west side of the peninsula. The founder of the Mahratta power was Sivaji, a freebooter or adventurer, whose father, Shahji Bhonsla, was an officer in the service of the last king of Bijapur. By policy or by force, he eventually succeeded in compelling the several independent Hindu chiefs to acknowledge him as their leader, and with the large army then at his command overran and subdued a large portion of the emperor of Delhi's territory. His son and (1680) successor, Sambhaji, after vigorously following out his father's policy, was taken prisoner by Aurungzebe in 1689, and put to death. His son, a prisoner, resigned his rule to his minister, with the title of *Peshwā*; the descendants of Sivaji henceforward reigned over but did not govern Sattara (see INDIA, p. 118). Under the fourth hereditary Peshwā there were five Mahratta states, more or less powerful and independent: that of the Peshwā at Poona; that of the Bhonslas at Nagpur; Gwalior, ruled by Sindhia; Indore, by Holkar; and Baroda, by the Guicowar. The invasion of the Delhi empire by Nadir Shah afforded these wild and warlike mountaineers an opportunity, of which they eagerly availed themselves, to wrest additional territory from the feeble grasp of the Mogul emperor. From this time they discharged the office of arbiters in the quarrels between the emperor, his vizier, and his rebellious subjects; but the frightful defeat (January 1761) they sustained at the hands of Ahmed Shah Durāni, the ruler of Afghanistan, on the field of Panipat, where they lost 50,000 men, and all their chiefs except Holkar, weakened their power for a time. They still, however, continued to be the hired mercenaries of the Delhi emperor, till the growing influence of the British compelled them to look to their own safety. After many long and bloody contests with the British and their allies (1780, 1803, 1817-18), in which sometimes the whole, but more frequently a portion of the Mahrattas joined, they were one by one, with the exception of Sindhia, reduced to a state of dependence. This last-mentioned chief, having raised a powerful army, officered by Frenchmen, and disciplined after the European method, continued the contest for a number of years, till his power was finally broken in 1843. The dignity of Peshwā was abolished in 1818, and his territories were occupied by the British. The Mahrattas are almost all now in British or Mohammedan states; in the states called Mahratta states (Gwalior, Indore, Baroda; see INDIA, p. 110) only the prince and his relatives are Mahrattas, the people being of other stocks. See Grant-Duff's *History of the Marāthas* (1826).

Mahwa-tree. See BUTTER-TREE.

Mai, ANGELO, CARDINAL, a distinguished Italian scholar, was born in the village of Schilpario, in Lombardy, March 7, 1782. He was educated and lived till 1808 in Jesuit establishments, next was a secular priest at Milan, and became custodian of the Ambrosian Library there. Here he devoted himself to palaeography, and during the next six years discovered a series of long-lost works, many from palimpsests. Among these were fragments of some of Cicero's *Orations*; of *Plantus*, especially of the *Fidularia*, a lost play; of *Letters*

of Fronto, the preceptor of Marcus Aurelius; of Isæus, Themistius, Dionysius of Halicarnassus, Philo, Porphyrios, and the *Chronicon* of Eusebins. All these, however, were eclipsed by his well-known edition and restoration of the *De Republica* of Cicero (1822). Meanwhile Mai had been invited to Rome by Pius VII., and named to the charge of the Vatican Library. He at once turned his attention to the unedited MSS. of the Vatican, and undertook the task of publishing those among them which had been neglected by earlier editors; and although appointed in 1833 to the onerous office of secretary of the Propaganda, and in 1838 to the cardinalate itself, he found time to superintend a series of publications almost unexampled in extent and importance in modern times. His first series was in ten quarto vols., entitled *Scriptorum Veterum Nova Collectio, e Vaticanis Codicibus edita* (1825-38). It consists, like the great collections of Mabillon, Montfaucon, D'Achéry, and others, of miscellaneous unpublished Greek and Latin works, partly sacred, partly profane, comprising an entire volume of palimpsest fragments of the Greek historians, Polybius, Diodorus, Dion, Dionysius, and others. The succeeding collections, *Classicorum Auctorum Collectio, e Vaticanis Codicibus edita* (10 vols. 1828-38), *Spicilegium Romanum* (10 vols. 1839-44), and *Patrum Nova Bibliotheca* (6 vols. 1845-53), are all on the same plan, and all equally replete with new and interesting materials. For many years Cardinal Mai was engaged in preparing an edition of the celebrated *Codex Vaticanus*, but long postponed its publication with the intention of preparing preliminary dissertations. But death overtook him unexpectedly near Albano, September 9, 1854; and the edition was ultimately published without these (5 vols. 1858). This work was far from being entirely satisfactory, and has since been superseded by the edition of Verecclione and Cozza (1868). Cardinal Mai's library was bequeathed, at half its estimated value, to the Vatican, for the good of the poor of his native village.

Maiden. THE. See GUILLOTINE.

Maidenhair (*Adiantum Capillus-Veneris*), a small, delicate, and graceful fern, with bipinnate fronds, alternate obovate and wedge-shaped membranaceous pinnules on capillary stalks, and marginal *sori* hidden beneath oblong *indusia*; growing



Maidenhair:
a, *Adiantum Capillus-Veneris*; b, *Adiantum cuneatum*.

on moist rocks and old walls, especially near the sea; rare in Britain, but very abundant in the south of Europe, where it covers the inside of wells and the basins of fountains (as at Vancluse) with a tapestry of the most delicate green. Another

species of the same genus, *A. polatum*, a native of North America, with *polate* leaves, has a sweet, fragrant root-stock, of which Capillaire (q.v.) is made. It is supposed that the name maidenhair originated in the use of a mucilage made from this fern by women for stiffening their hair. This name is sometimes applied also to some species of spleenwort (*Asplenium*), as *A. adiantum nigrum* and *A. trichomanes*. It is also applied to the *Adiantum* family generally, of which there are many species and varieties. The most common of all and best known popularly is *A. cucullatum*, a Brazilian species, which is much cultivated by florists.

Maidenhead, a municipal borough and market-town of Berkshire, with a population (1891) of 10,607, is situated amidst beautiful scenery 13 miles E. by N. of Reading, and 26 W. of London, and on the right bank of the Thames, over which are two bridges, one of stone, built 1772 at a cost of £20,000, and the other of brick, on the Great Western Railway (described Vol. II. p. 439). With the exception of a recreation-ground of 12 acres, opened 1890, there is little of interest in the town, which in 1399 was the scene of an engagement between the rival forces of Richard II. and Henry IV., and in 1647, at the Greyhound Inn, of the interview of Charles I. with his children. On the opposite, or Bucks, side of the river is Taplow (pop. 1063), whose wooded slopes are crowned by 'Cliveden's proud alcove.' The present house dates only from 1851; two previous mansions—in the earlier of which Thomson, whilst on a visit to the father of George III., probably composed 'Rule Britannia'—having been destroyed by fire in 1795 and 1849.

Maidment, JAMES, Scottish antiquarian and literary collector, was born in London in 1794, being descended on his mother's side from Jan van Olden Barneveldt, the Dutch patriot. He was educated at the High School and university of Edinburgh, and was called to the Scottish bar in 1817. He became almost the greatest authority in Scotland on genealogical law cases, and took a prominent part in the Mar peerage case and others. He died in Edinburgh, 24th October 1879. The passion of his life was the collection of literary rarities, often not of a very choice character. His most ambitious publication was *The Dramatists of the Restoration* (14 vols. 1872-75), edited with W. H. Logan; besides this he edited *A North Country Garland, a Collection of Ancient Ballads* (1824; new ed. 1884); *Scottish Pasquils or Lampoons* (1827-28; new ed. 1868); *New Book of Old Ballads* (1844; new ed. 1885); *Scottish Ballads and Songs* (1859 and 1868); *Packet of Pestilent Pasquils* (1869); an *Account of the Bonnytown Club*; and several historical, antiquarian, and genealogical works.

Maids of Honour. See HOUSEHOLD.

Maidstone, the county and assize town of Kent, is seated on the right bank of the Medway, 34 miles ESE. of London by road (41½ by rail), and 25 W. of Canterbury. At its west entrance, overlooking the river, which is spanned by a three-arch stone bridge, built 1877-79 at a cost of £55,000, stand the picturesque remains of All Saints' College (of which William Groeyn was once master), originally established in 1260 as a hospital for pilgrims travelling to Canterbury, and, like all other institutions of the same kind, suppressed in the reign of Edward VI. Close by is All-Saints' Church, a fine example of the Perpendicular style, built towards the end of the 14th century, and restored 1860; its interior is 227 feet long, and contains many interesting monuments and brasses, and a fine organ (1880). From the tower, 78 feet high, formerly rose a spire of 94 feet, which was destroyed by lightning in 1731. To the north

of this, the principal of Maidstone's ten churches, are schools of art and music, occupying a former palace of the archbishops of Canterbury; and other features of interest comprise a grammar-school, at which Sir Egerton Brydges was educated, founded 1549, and rebuilt on a new site, 1871; museum and public library, established 1858 in Chillington House, where, too, are the headquarters of the Kent Archaeological Society; town-hall (1764); county gaol (1812-19), built of Kentish rag-stone, obtained from adjacent quarries; hospital (1832-80); cavalry and militia barracks; corn exchange (1835); ophthalmic hospital (1851-69); and a public park on Penenden Heath to the NE. of the town, where formerly were held the county elections and other great meetings. Lining the river-banks are numerous paper-mills and a large oil-mill, whilst several breweries are in operation, and an important traffic is carried on in hops. Maidstone returned two members to parliament till 1885, when the number was reduced to one, and was first incorporated as a municipal borough in 1548; it gives the inferior title of viscount to the Earl of Winchelsea. Pop. (1801) 8027; (1831) 15,387; (1881) 29,623; (1891) 32,145. The history of the town is bound up with that of Kent (q.v.), the only special incidents identified with Maidstone being its storming in 1648 by Fairfax, when garrisoned by a royalist force, which only surrendered after a desperate resistance. Woollett the engraver, Hazlitt the essayist, and Newman Hall were natives; and Sir Thomas Wyatt the poet, and his son, the rebel, lived at Allington Castle, 2 miles distant. There was a terrible visitation of typhoid fever in September and October 1897, due—as was proved—to defective and polluted water-supply.

See works by J. M. Russell (1881) and Rev. J. Cave-Browne (1889).

Maigre (*Sciana aquila*), a fish of the acanthopteros family Scenidae, common in the Mediterranean but rare on British shores. It is usually 3 feet, sometimes 6 feet long. It resembles a large bass and is excellent for the table.

Mail. See ARMOUR, POST-OFFICE.

Maidun, the hero of an ancient Irish romance, first translated by Dr Joyce in his *Ancient Celtic Romances* (1879), and supposed by him to be the product of a rich and vivid imagination, working freely on a real voyage made in the beginning of the 8th century. The story forms one of the four extant *Laurina* or voluntary sea-expeditions, of which the most famous is the 6th-century voyage of St Brendan; and it has been made familiar to all readers in the splendid verse of Tennyson. Maidun was the son of Allil Ocar Aga, of the tribe of Owenaght of Ninnis, in the north-west of County Clare, and before his birth his father was killed by a band of sea-robbers. He grew up handsome and accomplished, but had scarce reached manhood before he set sail in a triple-hide curragh with a crew of sixty men to find his father's murderer. For three years and seven months he voyaged on the western sea, seeing marvels such as no eyes had seen before. He visited islands of monstrous ants, of blood-thirsty quadrupeds, of red-hot animals, and of those which turn themselves round inside their skins, as well as the isles of the blest, of laughing, of weeping, of intoxicating wine-fruits, of the mystic lake, of the burning river, of the crystal bridge, and the four precious walls. Further wonders were the demon horse-race, the palace of solitude, the miller of hell, speaking birds, a water-arch in the air, and the silver pillar of the sea. At length Maidun found the murderer of his father, but forgave him his wrong because of the great mercy of God in having delivered himself from so many dangers.

Maimana, an Uzbek state tributary to Afghanistan, and virtually a province of that country, situated on the northern frontier next Russian Turkestan; it has an area of about 4750 sq. m., and a pop. of 100,000, mostly warlike Uzbeks and Tajiks. The country is mountainous. The capital is Maimana, SW. of Balkh, 25 miles from the frontier. Previous to the seizure of the place by the Afghans, in 1874, it was a considerable town, but is now a village of 2500 inhabitants, who trade in horses, carpets, and dried fruits.

Maimansingh, a district of the Bengal division of Dacca, the capital of which is Nasirabad.

Maimatchin, a Chinese trading-town on the northern boundary of Mongolia, opposite Kiachta (q.v.), from which it is separated by a narrow strip of neutral territory. Pop. 3000.

Maimbourg, LOUIS (1610-86), a French Jesuit church historian, was expelled in 1685 from the order for his defence of Gallicanism, but became a pensioner of Louis XIV. He wrote histories of Wyclitism, Lutheranism, Calvinism, and of the prerogatives of the Church of Rome.

Maimon, SOLOMON, philosopher, was born of Jewish parents about 1754 in a village on the Niemen, near Mir, in the west of what is now the Russian government of Minsk. His mind was trained in the study of the Talmud, and he qualified for a rabbi. But possessing a burning desire for truth, and having become acquainted with the philosophy of Maimonides, he made his way to Berlin, and studied modern philosophy, languages, and some science. A child of nature, with the strong, subtle intellect of the born philosopher; shy, eccentric, dirty, and unmethodical; improvident, intemperate, and wholly irregular in his habits, Maimon led a vagabond life, battling against chronic poverty, and always dependent upon his friends for the bare necessities of existence. Besides cultivating his own mind, and teaching a little, he never did any work, except write some philosophical treatises and literary hack-work, done anywhere and at any time, mostly in poor taverns. Yet this ragged philosopher had Mendelssohn, the philosopher, among his friends, was admired by Kant, and attracted the attention of Goethe. This good fortune he owed to his *Versuch einer Transcendentalphilosophie* (1790), an eclectic system, in which he attempted to supplement Kant's by truths gleaned for the most part from Spinoza, Leibnitz, Hume, Locke, and others. He died in the house of Count Kalkreuth, his last patron, at Siegersdorf, in Lower Silesia, on 22d November 1800.

See his very interesting *Autobiography* (1792; Eng. trans. by J. Clark Murray, 1888); S. J. Wolf's *Maimoniana* (1813); and the Life by Witte (Berlin, 1876).

Maimonides, the name by which Christians generally know the great Jewish teacher, Rabbi Moses ben Maimon, who from the initials of these words is called by the Jews RAMBAM. He was born at Cordova, March 30, 1135, and received his first instruction from his father. Under the most distinguished Arabic masters of the time he then devoted himself to the study of Greek (Aristotelian) philosophy, the science of medicine, and theology. Under the Almohades his family had to conform outwardly to Mohammedanism, and ultimately emigrated to Egypt, and Maimonides became physician to the reigning sultan, Saladin. At Cairo he died December 13, 1204. His importance for the religion and science of Judaism, and his influence upon their development, are so gigantic that he has not unjustly been placed second to Moses, the great lawgiver, himself. He first of all brought order into those almost boundless receptacles of tradition, and the discussions and

decisions to which they had given rise, which, without the remotest attempt at system or method, lie scattered up and down the works of Haggada and Halacha—Midrash, Mishnah, Talmuds. Imbued with the spirit of lucid Greek speculation, and the logical thought of the Arabic Peripatetics, Maimonides, aided by an enormous knowledge, became the founder of rational Scripture exegesis. The Bible, and all its written as well as implied precepts, he endeavoured to explain by the light of reason, with which, as the highest divine gift in man, nothing really divine could stand in real contradiction. The miracles themselves, though not always traceable to their immediate cause, yet cannot be wrought in opposition to the physical and everlasting laws in nature. Where literal interpretation seems to jar upon the feelings of reverential awe towards the Highest Being, there an allegorical explanation is to be adopted unhesitatingly. As to the philosophical system of Maimonides, we can barely hint at its close similarity with that of Averroes. Maimonides fully allows the freedom of will, and holds that providence reigns in a broad manner over humanity; but he utterly denies the working of providence in the single event that befalls the individual, who, subject above all to the great physical laws, must learn to understand and obey them. The soul, and the soul only, is immortal, and the reward of virtue consists in its unbodily bliss in a world to come; while the punishment of vice is the 'less of the soul.'

Maimonides' first work of paramount importance is his Arabic commentary of the Mishnah, which forms an extensive historical introduction to *Tradition*, or the Oral Law; and this introduction, translated into Hebrew, has now for more than five hundred years been deemed so essential a part of the Talmud itself that no edition of the latter is considered complete without it. This was followed by the *Safer Hamitzvot*, or Book of the Precepts, in Arabic, which contains an enumeration of the 613 traditional laws of the Halacha; the text was first edited by M. Bloch (Paris, 1888). This book is to be considered chiefly as an introduction to the gigantic work which followed in 1180, under the title of *Mishne Torah* ('Second Law'), or *Yad Chasakoth* ('Strong Hand'), a Hebrew compendium in 982 chapters, embracing the entire Halacha. The summit of his renown, however, Maimonides reached in his grand Arabic work, *Delaloth Al-Ha'irin* (translated into Hebrew by R. Tibbon as *Morah Nebuchim*, 'Guide of the Erring'), a philosophical exegesis, which, while on the one hand it has contributed more than any other work to the progress of rational development in Judaism, has on the other hand also become the arena for a long and bitter fight between orthodoxy and science, between the spiritualistic Maimonidian and the 'literal Talmudistic' schools. Ultimately the antagonistic parties came to a reconciliation, and Maimonides' name became the pride and glory of the race; and as early as the 13th century, already portions of his works, chiefly the *Morah* ('Doctor Perplexorum'), became, in Latin versions, the text-books even of European universities. See *The Guide of the Perplexed of Maimonides*, translated and annotated by Friedlander (3 vols. 1886); and his Life of Maimonides.

Main, a river of Germany, the largest affluent the Rhine receives from the right, is formed by the union of two branches, the White and the Red Main, 4 miles below Kulmbach, in north-east Bavaria. The White Main rises in the Fichtelgebirge, 2900 feet above sea-level; the Red Main, a few miles S. of Bayreuth. The river flows westward by huge zigzags past Bamberg, Schweinfurt, Würzburg, Aschaffenburg, Hanau, Offenbach, and

Frankfort, and mingles its yellow waters with the green current of the Rhine opposite Mainz, after a total course of 307 miles, the last 205 of which are navigable. The chief affluents are, on the right, the Saale, and on the left, the Regnitz. The Main flows through a beautiful country, the hill-slopes generally covered with vineyards and surmounted by castles. Its waters communicate with those of the Danube by means of the Ludwigs-Kanal and the Altmühl. The Main divides politically North Germany from South Germany.

Maine, an old province of France, having Normandy on the north, Brittany on the west, and Anjou on the south, corresponded to the modern departments of Sarthe and Mayenne. Its chief town was Le Mans.

Maine, the north-easternmost state of the American Union, is bounded N. by the Canadian provinces of Quebec and New Brunswick, E. by New Brunswick, S. and SE. by the Atlantic Ocean (Gulf of Maine), W. by New Hampshire, and NW. by the province of Quebec. Area, 33,040 sq. m., of which one-tenth is water, there being many large and fine lakes (Moosehead, Chesuncook, Sebasticook, Grand, Sebago, &c.) and important rivers (Penobscot, Kennebec, Androscoggin, Saco, St Croix, Aroostook, and Wallowoosook or St John). It is thus somewhat larger than Ireland. Measured in a direct line the coast extends some 270 English statute miles, but if its sinuosities and the outlying island-shores were measured it is estimated that the whole would be extended to about 2500 miles. When the poet Whittier speaks about 'hundred-harbour'd Maine,' he scarcely exaggerates, for the rocky coast-line, broken by the force of the waves and trenched in former geological times by glaciers, forms almost that number of anchorages, some of them highly important for their commerce, and others serving as harbours of refuge. Towards the south-west the shore is sandy, and there are salt marshes, producing much coarse hay. The surface is uneven, and in the north-central regions and the west it is even mountainous. The scenery at some points (as on Mount Desert Island, on some of the lakes, and in the region near Camden) is very picturesque. The highest mountain is Katahdin (5385 feet). The soil is mostly stony and hard, as in New England generally, but some sections are very fertile—the Aroostook region in the north-east for the most part exceedingly so. The northern portion of the state is covered in great part with a dense forest, and its population is very sparse.

The geological features are complex, but a great proportion of the strata shows metamorphic traces. The surface is everywhere scored with prehistoric glacier and drift ice. Granite is very extensively quarried, and presents many handsome varieties. Excellent lime is largely produced. Traces of coal are found (as at Georgetown and Bucksport), and there are local beds of valuable graphite. The state is rich in rare minerals. Many silver-mines have been opened, and a few are still operated in a small way; but the ores (sulphide of silver accompanying galena, &c.) are often rebellious and expensive to work. Vast beds of copper (bornite, chalcocite, chalcopyrite) exist, some of them quite rich. Felspar, flag-stone, limonite, mica, yellow-ochre, glass sand, slate, the latter in vast quantities and of high grade, lead ores, talc, tripoli, and manganese are all wrought to a greater or less extent. Tourmaline is obtained as a precious stone, for jewellers' use; and lepidolite, a mineral rich in the rare metal cesium, is locally found in considerable abundance. Mineral waters are shipped in large quantities.

The cool climate and the opportunities for fishing and shooting make this state a favourite region for summer resort. The winter climate is severe for the latitude; the winters are long and the snows deep. Ice, which is harvested especially on the Kennebec, is an important commodity for export. The leading crops are hay, potatoes, apples (of excellent quality), and the ordinary grains and small fruits. The sweet varieties of maize (sugar-corn) are extensively cultivated, and are sold largely in tins and glass for winter consumption; this is a prominent industry in some sections. The rainfall is copious. The rivers of Maine afford an enormous water-power, only a relatively small part of which is at present utilised. Forest products (timber, tan-bark, &c.) are extensively cut. Navigation is favoured by the numerous inlets and the large navigable streams, and railway communication is fairly developed. Timber, building-stone, ice, cattle, wool, and farm products are shipped. Maine has considerable shipbuilding (more than any other state), and the coasting trade is carried on largely. The fishing interests are extensive: mackerel, lobsters, herring, 'sardines' (here mostly small herring), fish-oil, and fish-guano are the staple products of the fisheries. The principal manufacturing industries of the state are the making of cotton and woollen goods, leather, boots and shoes, flour, paper, and foundry products, the sawing and planing of lumber, shipbuilding, the canning of fruit and lobsters, &c.

Maine contains sixteen counties, and returns four members to congress. The chief towns are Portland, the largest city and principal seaport; Bangor, on the navigable river Penobscot; Lewiston, the seat of extensive cotton manufactures; Augusta, the state capital; Bath, noted for its shipbuilding; Auburn, Belfast, Rockland, Biddeford, Saco, Brunswick, Brewer, Eastport, Gardiner, Hallowell, Waterville, &c. Education is general and on the whole progressive. There are colleges of repute at Brunswick, Waterville, Lewiston, and Orono, the last a state institution. The Maine Liquor Law, one of the earliest of the stringent Liquor Laws (q.v.; and see TEMPERANCE), was enacted in 1851. The population is mainly of the English Puritan stock of New England. There is a large element of French-speaking Canadian immigrants, and in the extreme north there is a considerable body of Acadian French who have occupied for nearly 150 years a fertile region on the river St John. Latterly there has been an influx of Irish, Swedish, and German settlers. An old German colony near the coast has become completely Americanised. There are a few Indians left in the state; but the African element is very small indeed. Pop. (1820) 298,335; (1860) 628,279; (1880) 648,936; (1890) 661,086.

History.—The early Dutch settlements did not prove permanent. The English established settlements here as early as 1607, but with no success. The French planted an unsuccessful colony on Neutral Island in 1604, but all their attempts at colonisation on the coast were speedily abandoned. Bristol or Pemaquid was settled in 1630, and had an interesting early history, becoming in 1648 a centre of a new but temporary 'Dual State' subject to the Duke of York, afterwards James II. York, settled probably in 1621, was the capital of a colony under Sir Ferdinando Gorges (q.v.). In 1635 the western part of Maine received the title of the Province of Maine, and from 1651 to 1820 it formed a detached part of Massachusetts, called the district of Maine; Massachusetts in 1677 bought the title to the Gorges colony. Eastern Maine until 1691 formed a part of Acadia or Nova Scotia. Maine became a state in 1820. An angry dispute with Great Britain as to the northern and eastern

boundary was settled in 1842 by a compromise. Latterly the depletion of the pine-forests and a large emigration to the West have checked the material progress of Maine, but its healthful climate and its natural resources ensure to the state a prosperous future. See G. J. Varney, *Brief History of Maine* (Portland, 1889).

Maine. SIR HENRY JAMES SUMNER, was born in 1822, and had his education at Christ's Hospital and Pembroke College, Cambridge, where his career was unusually brilliant. He carried off the Craven scholarship and other university prizes, and graduated in 1844 as senior classic and Chancellor's classical medallist, as well as a senior optime in mathematics. Soon after he was elected fellow and tutor of Trinity Hall, and in 1847, at the age of twenty-five, was appointed regius professor of Civil Law, which office he vacated in 1854 to become Reader on Jurisprudence at the Middle Temple. He was called to the bar in 1850, and went to India in 1862 as Law Member of the Council in India—an office held by Macaulay, and in which he himself was succeeded in December 1869 by Sir James Fitzjames Stephen. In 1870 he was appointed to fill the new chair of Comparative Jurisprudence at Oxford, and next year to a seat in the Council of the Secretary of State for India, on which occasion he was created K.C.S.I. At the close of 1877 he was elected Master of Trinity Hall at Cambridge, and in 1887 also Whewell professor of International Law. But his health was already broken, and on February 3, 1888, he died of apoplexy at Cannes. Maine gave some wise reforms to Indian law, but it is by his work on the origin and growth of legal and social institutions that his name will be best remembered. His books were *Ancient Law* (1861), one of the most important and influential works of its time; *Village Communities in the East and West* (1871); *The Early History of Institutions* (1875); *Early Law and Custom* (1883); and *Popular Government* (1885). One fundamental idea of Sir Henry Maine's was to make paternal or patriarchal power the germ from which society developed. This view was strongly controverted by M'Lennan, Morgan, and Spencer; but Maine's answer was marked by equal learning and far greater lucidity and grace of exposition. See the Memoir by Sir M. E. Grant Duff (1892).

Maine-et-Loire, a department of France, formed out of the old province of Anjou, and watered by the rivers whose names it bears, is divided into the arrondissements of Angers, Beaugé, Cholet, Saumur, and Segré. Area, 2749 sq. m.; pop. (1872) 518,471; (1886) 527,680; (1891) 513,815. The soil is fertile, and produces excellent corn and wine, with hemp, linseed, fruit, and green crops. Slate quarries and coal-mines are worked; and there are mills for cotton, woollen, and linen manufactures. Capital, Angers.

Mainotes, the inhabitants of the mountainous peninsula of Maina, that lies between the gulfs of Koron and Marathonisi in the extreme south of Greece. They claim to be the descendants of the ancient Spartans, number close upon 50,000, and are a well-built race, industrious and hospitable, but revengeful, great lovers of liberty, and formerly implacable foes of the Turks. They took a prominent part in the war for the liberation of Greece. In 1676 about 1000 Mainotes emigrated to Corsica; their descendants still survive at Cargèse in that island. Amongst the emigrants were some bearing the name of Kalomeros, which in Italian is translated Buonaparte. Hence the people of Maina believe that the great Napoleon was of Greek origin. The emigrants were settled at Ajaccio from 1729 down to 1769, in which year Napoleon was born there.

Mainpuri, capital of a district in the North-western Provinces of India, 75 miles E. of Agra. Pop. (1881) 20,236.

Maintenance is a law-term commonly used to denote an illegal succouring of a person, as by lending money to a stranger in carrying on law-suits. Contracts are sometimes held to be illegal on this ground. At Guildford, in July 1889, a man got six months' imprisonment with a fine of £200 for maintenance and Barratry (q.v.).

Maintenance, CAP OF, sometimes called *Cap of Dignity*, a cap of crimson velvet lined with ermine, with two points turned to the back, originally only worn by dukes, but afterwards assigned to various families of distinction. Those families who are entitled to a cap of maintenance place their crests on it instead of on a wreath. See HERALDRY, p. 667.



Cap of Maintenance.

Maintenon, FRANÇOISE D'AUBIGNÉ, MARQUISE DE, famous for her connection with Louis XIV., was the daughter of Constant d'Aubigné, the worthless son of the famous Huguenot, Théodore Agrippa d'Aubigné, and was born in the prison at Niort, November 27, 1635. When four years old she was carried to Martinique in the West Indies, whence she returned after her father's death in 1645 to France. Her conversion to the Roman Catholic religion was effected not without difficulty, and on her mother's death she found herself at fifteen reduced to absolute penury. Soon after this she became acquainted with the kind-hearted poet Scarron, who offered either to marry her himself or to pay the money required for her entrance into a nunnery. Although Scarron was lame and deformed, she chose to marry him, and for nine years lived contentedly in the midst of the intellectual society which frequented the house of the poet. On his death (1660) she was again reduced to great poverty; but Anne of Austria continued and increased her husband's pension. On her death (1666) it was discontinued, and she was about to go as a governess to Portugal, when Madame de Montespan obtained for her the continuance of her pension. In 1669 she was given the charge of the king's two sons by Madame de Montespan, and in this capacity displayed a patient tenderness and sleepless care that no mother could have surpassed. By 1674 she had made sufficient money to buy the estate of Maintenon, and four years later had it made a marquise by the king. She had now completely established her ascendancy over the heart of Louis, who made her in 1680 second lady-in-waiting to the dauphiness. The queen died in 1683, and Madame de Maintenon, who had become first lady-in-waiting to the dauphiness the year before, married the king privately in the winter of 1685. Her morals were severe, for her heart was never other than cold, and she knew that the best cards for her game were propriety, orthodoxy, and the church. Her moral influence over the court would have been greater had she filled a more recognised position. Her political influence was supreme in all but the more important questions of policy, and she lavished her patronage upon persons devoted to herself. She was a liberal patroness of letters, and, while she had a high reputation for orthodoxy, had too much humanity to approve of the detestable *dragonnades*. Yet in the midst of splendour, and in the possession of great power, she was unhappy, and she often turned for solace to the home for poor girls of good family she had established at

St Cyr, and for which she laboured with the most ceaseless care. Hither she retired when the king died in 1715, and here she died, April 15, 1719. Her pretended *Memoires* (6 vols. 1755) are spurious, but her delightful and admirable *Lettres* (9 vols. 1756) are genuine. By far the best editions are by T. Lavalée (1854-56) and M. Gellroy (2 vols. 1887).

See the books by Madame Suard (1810), Lafont d'Aussonne (1814), and the Duc de Noailles (1848-58); also Théophile Lavalée's *Histoire de St Cyr*, and its review in vol. viii. of Sainte-Beuve's *Causeries du Lundi*; the studies by Cœter Morison (1885) and Emily Bowles (1888); vol. ix. of Scherer's *Études sur la Litt. Cont.*, and Dollinger in *Althainische Zeitsung* (1886).

Mainz (*Mayence*), an imperial German fortress of the first rank, and the seat of a Roman Catholic bishop, in the grand-duchy of Hesse, is situated on the left bank of the Rhine, opposite the junction of the Main, 22 miles WSW. of Frankfurt. The Rhine is here crossed by a stone bridge (superseding in 1885 the former pontoon bridge) to the village of Kastel, included in the fortifications, and by an iron railway bridge, 140 yards long, to the port of Gustavsberg, at the mouth of the Main. Pop. (1875) 56,421; (1890) 72,059, of whom two-thirds are Roman Catholics; in the 14th century it is said to have reached 90,000. Mainz is one of the most ancient cities in Germany; but its oldest part, known as *Kastel*, has been rebuilt in a modern style since its almost total destruction in 1857 by the explosion of a powder-magazine; while a handsome new quarter has sprung up on the north, in the space afforded by the advancing of the fortifications in 1874. The cathedral, originally built in 978-1009, was thrice destroyed by fire, and dates in its present form from the 13-14th century. In 1870-78 it was thoroughly restored, and the present central Romanesque tower, 270 feet high, built. It has five lesser towers, fourteen altars, and nine minor chapels, and is adorned in the interior with frescoes and numerous monuments. Besides various modern public buildings, the city contains the palace of the grand-duke, originally a lodge of the Teutonic Order, dating from the beginning of the 18th century, an arsenal of 1736, and the large red-sandstone electoral palace, in which are deposited various public collections, including a Bibrary of 150,000 vols., and the valuable Romano-German Museum, an antiquarian and historical collection unequalled elsewhere in Europe. Mainz is an important centre of the Rhine trade with Holland and Belgium, and also carries on a very large transit trade by railway, as well as an active manufacturing industry. Elaborate new harbour-works, including docks and storehouses, were opened in 1887 at a cost of £250,000; while the Rhine is skirted by a broad quay, four miles long. Grain, wine, timber, books, music, and the manufactures of the town are the chief articles of trade. Furniture, leather goods, machinery, musical instruments, chemicals, gold and silver ware, hats, soap, &c., are among the manufactures; and brewing, printing, and market-gardening in the environs are also important industries. The history of Mainz connects it with Rome from the year 13 B.C., when Drusus built on its site the important fort of *Moguntiacum* or *Moguntiana*. Among the numerous Roman remains the most remarkable are the *Euplstein*, a column supposed to mark the tomb of Drusus, and the remains of an aqueduct 3½ miles long. The real importance of the town dates, however, from the Frankish emperors. In the 13th century Mainz was the head of the confederacy of the Rhenish cities, but in 1462 it was added to the domains of the archbishops of Mainz, the premier spiritual electors of the empire. The city was several times in the possession of France, notably

in 1801-14. After the Congress of Vienna it was assigned in 1816 to Hesse-Darmstadt, on condition that it was to constitute a federal stronghold, and it was garrisoned by Prussian and Austrian troops. After 1866 it was held by Prussian troops, until in 1870 it was declared an imperial fortress. Mainz was the birthplace of Gutenberg (q.v.), whose house is still pointed out. See works by Schnab (1844), Bockenheimer (1879), Beck (1882), and Schneider (1886).

Maison Carrée. See NIMES.

Maistre, JOSEPH MARIE, COMTE DE, was born 1st April 1751, at Chambéry, of a noble French family which had settled in Savoy. While Savoy was occupied in 1792 by the French, De Maistre, who was a member of the senate, withdrew from the country; and when the king of Sardinia retreated to the island of Sardinia, he accompanied his court. In 1803 he was sent as ambassador to St Petersburg, and here he remained until 1817, when he was recalled to occupy a place in the home government. Thereafter he lived in Turin till his death, February 25, 1821. De Maistre was an ardent ultramontane, and argued with an incisive force of logic and brilliancy of rhetoric more often associated with the opposite side. He maintained the pope as the source and centre of all earthly authority, and an ordered theocracy as the only protection from social and religious anarchy. He is an unusually strong and steady thinker, and has a remarkable faculty of forcing plain arguments forward to an irresistible conclusion. He is profoundly learned as well as logical, and, in short, is much more easily denounced than answered. His first work was *Considérations sur la France* (1796), an able defence of Legitimist views, and onslaught on the *philosophes* of the 18th century. In St Petersburg he wrote his *Considérations Politiques* (1810), *De l'Église vaticane* (1821-22), *Succées de St Petersburg* (1822). The last is unfinished and desultory, but is pregnant with strong thought and suggestiveness. Here is to be found the panegyric on the hangman as the foundation of social order. Other works are his *Éssai de la Philosophie de Bacon* (1836) and *Lettres et Opuscules* (1851). See Life by Glaser (Ber. 1865), by Margerie (Par. 1886); Sainte-Beuve's *Portraits Cont.* (vol. iii.); John Morley's *Critical Miscellanies*; Descotes, *Joseph de Maistre avant et pendant la Révolution* (1893-94); and other books by Lesene (1893) and Cogordan (1894).

XAVIER DE MAISTRE, his younger brother, was born at Chambéry in October 1763, and from an early age served in the Sardinian army. He shared his brother's politics, and after the campaign of 1799 followed Suwaroff to Russia. Here he served with distinction, rising to the rank of general, married a Russian lady, and settled down, even after the fall of Napoleon had restored the dynasty of Piedmont. He paid visits to Naples and Paris, where Sainte-Beuve saw him, and died at St Petersburg, 12th June 1852. His name is remembered for a few delightfully fresh and unpretending books, written in perfect French, and showing that rare mastery of the narrative art in the simple fashion for which Sainte-Beuve sets him beside Prosper Mérimée. The best known is the *Voyage autour de ma Chambéry* (1794), a quaint fantasy, giving an account of a temporary confinement to his quarters at Turin, that might have been written by a stainless Sterne. *Le Léproux de la Cité d'Aoste*, a sweet and touching little story, shows the same inspiration and the same originality in the use made of it. Other stories are *Les Prisonniers du Caucase* and *La jeune Sibirienne*. The *Expédition Nautique autour de ma Chambéry* is a less successful continuation of his

earliest book. De Maistre's (*Œuvres*) appeared at Paris in 1825 (new edition, 3 vols. 1881). See Rey's *Xavier de Maistre* (1865).

Maitland, a town of New South Wales, on the Hunter River, 93 miles NNE. of Sydney by rail, and 20 NW. of Newcastle. It is divided by the river into East and West Maitland, which are separate municipalities. The town is the see of a Roman Catholic bishop. In either division are handsome banks, churches, and other public buildings. In West Maitland (much the more populous part) are several mills, coach-building, tobacco, and boot factories. Good coal abounds in the neighbourhood. Pop. of both divisions, 7300.

Maitland, the name of a Scottish family, celebrated in both the literary and political history of their country. The first who acquired distinction was SIR RICHARD MAITLAND of Lethington, son of William Maitland of Lethington and Thirlstane, who fell at Flodden, and of Martha, daughter of George, Lord Seton. He was born in 1496, studied at St Andrews and in France, and on his return to Scotland was successively employed by James V., the Regent Arran, and Mary of Lorraine. About 1551-52 he received the honour of knighthood, became a lord of the Court of Session in 1551 (before which, however, he had the misfortune to lose his sight), and Lord Privy Seal in 1562. He died 20th March 1586, at the age of ninety. Maitland was one of the best men of his time. In an age of violence, fanaticism, and perfidy, he was honourably conspicuous by his moderation, integrity, and anxiety for the establishment of law and order. He merits consideration not only as an eminent and upright lawyer, but as a poet, a poetical antiquary, and a historian. All his own verses were written after his sixtieth year, and show what things he had most deeply at heart. For the most part they consist of lamentations for the distracted state of his native country, the feuds of the nobles, the discontents of the common people, complaints 'against the lang proces in the courts of justice,' and the depredations 'of the border robbers.' Knox, in his *History of the Reformation*, says of him that he was 'ever civile, albeit not persuaded in religion.' A complete edition of Maitland's original poems was first published in 1830 by the Maitland Club (see BOOK-CLUB). Sir Richard's collection of early Scottish poetry was a work undertaken, if not completed, before his blindness attacked him. It consists of two MS. vols., the first containing 176, and the second 96 pieces; they are now preserved in the Pepysian Library, Magdalen College, Cambridge. Maitland's principal historical performance is the *Historie and Cronicle of the Hous and Surname of Setoun*, &c. See Brunton and Haig, *Scotlars of the College of Justice* (1832).

WILLIAM MAITLAND, best known in Scottish history as Secretary Lethington or Leddington, was the eldest son of Sir Richard Maitland of Lethington. The exact date of his birth is unknown, but it must have been between 1525 and 1530. He probably studied at St Andrews, though his name does not occur in any list of the graduates of that university, and he seems also to have spent some time in study on the Continent. Knox, who was not friendly to him, describes him as 'a man of good learning, and of sharp wit and reasoning.' At the outset of his public career he took the side of the party of reform in religion; but all through life he was the politician first and the reformer afterwards. In 1558 he became secretary of state to Mary of Lorraine, the Queen-Regent, and in the following year joined the Lords of the Congregation, who were in arms against her. His ability soon gave him a prominent place

in the councils of his new allies. In August 1560 he acted as speaker in the Convention of Estates, and the same year was sent to the English court to represent the interests of the Protestants. On the arrival of Mary in her kingdom in August 1561, Maitland associated himself with the queen's brother, afterwards the Regent Moray, in opposing what they deemed the extreme proposals of Knox. To Mary he at first made himself one of her most useful servants, and more than once represented her at the court of Elizabeth, where he proved himself a match even for the latter's astute minister Sir William Cecil. His importance in Scottish affairs is proved by the prominent place he holds in Knox's *History of the Reformation*, some of whose most interesting pages are devoted to his discussions with Leithington. By his connivance at the murder of Rizzio (1566) he made Mary his enemy, though he again became her adviser on the return of Moray after his temporary exile. At first, also, Maitland favoured the schemes of Bothwell, and was privy to the murder of Darnley, yet in the rising that took place on Bothwell's marriage with Mary he ostensibly acted with the insurgents. Nevertheless, after the defeat of the queen at Langside and her consequent flight to England, while seeming to act as a friend to the new government, he secretly favoured the exiled queen. He was one of the commissioners who accompanied Moray to present to Elizabeth their indictment against Mary (1568), but all the while he was plotting against his colleagues. On their return to Scotland the formation of a party in favour of Mary was mainly the work of Maitland. In spite of all his endeavours, however, this party was unable to hold its own against the government, supported as it was by English money and arms. Shut up in the castle of Edinburgh, Maitland and Kirkcaldy of Grange held out till 1573, when they were forced to surrender. Maitland, broken in health, died in prison in Leith a few days later, 'some,' says James Melville, 'supposing he took a drink and died, as the auld Romans were wont to do.' From his accomplishments and political adroitness, Maitland was one of the most notable figures of his time in Scotland; but it was his fatal defect as a statesman that, while all parties admired his ability, he gained the confidence of none. Knox regarded him as no sincere supporter of the principles of the Reformation, and Mary, on the other hand, both hated and suspected him. The rumour regarding the mode of his death may have been without foundation; but the rumour itself is a significant commentary on the character and principles of the man. See Buchanan's *Chambloun*, Skelton's *Maitland of Lethington* (2 vols. 1887-88). For John Maitland, Duke of Lauderdale, see LAUDERDALE.

Maiwand, 50 miles NW. of Kandahar, where an English army was defeated by Ayub Khan, 27th July 1880. See AFGHANISTAN.

Maize, or INDIAN CORN, is the produce of *Zea mays*, a species of cereal having monoecious flowers, the features of which are well illustrated in the accompanying cut. The stem, which is filled with a pithy, fibrous structure, is divided at irregular intervals by nodes, and its strength and solidity is increased by a siliceous outside covering. From the lowest, and sometimes also the second and third node, it sends out 'brace' roots, and these help to support the plant, which sometimes grows to 18 feet in height, the minimum being generally 3 feet. The ears—which are developed within the leaf-sheath at the nodes, and consist of a 'cob' with the grains disposed upon it in regular rows of from eight to twenty, and long 'silk' threads attached to each embryo, which usually extend

beyond the closely-folded tip of the mass of imbricated leaves ('husk') that wraps the whole—are from half an inch to 3 inches in diameter, and from 2 to 17 inches in length. The stem is topped by a 'tassel,' producing an abundance of light, dry, loosely-attached pollen. Maize is hardly a less staple article of food to the inhabitants of tropical and subtropical countries than rice, and is rapidly becoming popular in various forms in temperate and colder climates. It is held to be superior in nutriment to barley, buckwheat, and rye. By analysis it gives 77 per cent. of starch; 3 of zein, a principle analogous to gluten; 2.5 of albumen; 1.45 of sugar; .8 of extractive; 1.75 of gum; 1.5 of sulphate and phosphate of lime; 3 of lignin; and 9 of water. It is more generally used in America (North and South) than in the other continents—in the United States the crop is over 2000 million bushels, or about two-thirds of all the grains grown; but in the Mediterranean countries, Germany, &c., it is also highly valued. The green ears of the sweet varieties are boiled and eaten



Maize (*Zea mays*):
a, flower; b, ear.

from the kernel or served in milk. When coarsely ground maize forms the *hominy* of the southern states of America, and finer ground it furnishes the *mush* or porridge of the northern states; while the whole grains with the cuticle covering removed after being loosened by boiling in a weak lye, are the *hulled corn* of the states generally. *Pop-corn* is a variety whose grains can be roasted and turned and shaken smartly over a brisk fire till they swell and burst, turning inside out; in this state they are coated with syrup and pressed into a ball, or the separate grains are simply sprinkled with salt. The deficiency of gluten in the meal of maize renders it ill adapted to bread-making; but *johnny-cakes* made from it are popular along with bacon, &c., and mixed with rye-meal it forms the common brown bread of New England. Large quantities of starch are manufactured from maize, both for laundry purposes and for making puddings, custards, and blanc-mange; and the starch, by treatment with acid, is converted into glucose or grape-sugar (see SUGAR). The canning of green sweet corn is also an important industry in some states. By the Mexicans the small young shoots of thickly-sown crops are served at table like asparagus and as dessert. The stems of the sugar corn when full grown yield by pressure a thin sweet juice, which when fermented gives a pleasant syrup and from five to fifteen per cent. of sugar, fermented a beer called *chicha*, and distilled an excellent spirit resembling brandy. In countries where maize does not ripen well it is sometimes sown to afford food for poultry, or to be mown as green fodder for cattle. Where it is cultivated for its grain the dried leaves are used as winter fodder. The stalks are used for thatch and for fuel, and for making baskets.

The fibres of the culm and leaves afford a durable kind of yarn; and the husks are elastic, and can be applied to the stuffing of chairs, saddles, &c., and to the manufacture of good durable mattresses, which have become a profitable article of trade in Paris and Strasburg. The husks are also much used for packing oranges and lemons, and in South America for making cigarettes; and good paper has been manufactured from them. Hallowed corn-cobs make homely but serviceable pipe-heads for smoking tobacco. There are few plants of which the uses are more various than maize, and few which are of greater importance to man.—Another species of maize, called Chili Maize or Valparaiso Corn (*Z. Curauqua*), is distinguished by its serrated leaves. It is a smaller plant, a native of Chili, and has won a superstitious regard because its grains when roasted split in the form of a cross. Formerly in England maize was known by the name *Turkey wheat*, being then solely an article of trade from the East; but the name Indian corn, which was given it by the early settlers in America, gradually supplanted the earlier name as the supply from that country ousted that of the earlier sources from the British market. In America it is simply called corn. The native country of maize is uncertain. Humboldt and De Candolle are of opinion that it was introduced from the West Indies and the continent of America, but other authorities adduce good grounds for the contention that the plant is indigenous to or at least was known and cultivated in Asia and Africa before the discovery of America. In an ancient Chinese encyclopædia in the royal library at Paris is an excellent representation of the plant; so that while it was undoubtedly first introduced to Europe about the year 1520 by Columbus from America, there are good grounds for the conclusion that it was known and cultivated in the ancient world long before that time.

Majesty, a title of honour now usually bestowed on sovereigns. Among the Romans *majestas* was used to signify the power and dignity of the people, and after the overthrow of the republic became exclusively the attribute of the emperors. The *majestas* of the emperors of Rome was supposed to descend to those of Germany as their successors; but the adoption of the attribute by other European sovereigns is of comparatively late date. Its use began in England in the later part of the reign of Henry VIII., up to which time 'Your Grace' or 'Your Highness' had been the appropriate mode of addressing the sovereign. Henry II. was the first king of France who was styled 'Most Christian and Catholic Majesty,' the king of Spain came to be 'Catholic Majesty,' and of Hungary 'Apostolic Majesty.' All European emperors, kings, and queens are now generally addressed as 'Your Majesty.' The sovereign of the United Kingdom is personally addressed as 'Your Majesty,' and formal letters are addressed to 'The King's (or Queen's) Most Excellent Majesty.'

Majolica (from the Italian name of the island of Majorca, where this ware seems to have been first made), a decorated kind of enamelled pottery made in Italy from the 15th to the 18th century. It attained its greatest development in the duchy of Urbino, which included the four great manufactories of Pesaro, Gubbio, Urbino, and Castel Durante. Majolica is an earthenware usually of a coarse paste, covered with a stanniferous glaze or enamel. It has sometimes been called 'Raffaello ware' from the fact that a number of the paintings upon it were copied from the designs of that famous painter. Majolica is generally considered to be the most beautiful decorated pottery that was ever extensively made, at least during the Christian era.

Some of the finer pieces when they come into the market bring large, almost fabulous, sums of money. See POTTERY.

Major, in the Army, is the lowest rank of field-officer. There are two on the establishment of every infantry battalion in the British army and three on that of each cavalry regiment, one in command of each battery of artillery, about 150 in the engineers—promoted after twenty years' service whether vacancies exist or not—in the Royal Marine Artillery, and 42 in the Royal Marine Light Infantry. Previous to 1872 the majors of artillery and engineers were called first-captains. The duties of majors of infantry in the field, where they are always mounted, are generally to take up points on which the line is dressed and to command, one the supports, and the other the reserve in attack formation. In barracks they assist the commanding officer in all matters of interior economy and discipline. Cavalry majors perform similar duties, except that in the field each commands a squadron. In garrison all regimental majors and captains who for distinguished service have been given brevet rank as majors take their turn as president of district courts-martial and as field-officer of the day, attending guard-mounting, visiting the guards by day and night, taking command of picquets in case of fire, riot, or alarm, &c. The pay of a major ranges from 16s. a day in the infantry of the line to £1, 4s. 5d. in the household cavalry. In the United States army the yearly pay of a major is \$2500.

The word major is used also in conjunction with other military titles, thus: major-general is the lowest rank of General (q.v.); surgeon-major is the rank next above surgeon; a sergeant-major is a staff-sergeant superior to a sergeant; drum-major, trumpet-major, farrier-major, &c. are the old titles of the sergeant-drummers, sergeant-trumpeters, sergeant-farriers, &c. A corporal-major in the household cavalry corresponds to the regimental sergeant-major or senior non-commissioned officer in other corps.

Major, or MAIR, JOHN, was born near North Berwick, Haddingtonshire, about 1470. After receiving the elements of his education in Scotland, he studied at Oxford, Cambridge, and Paris. At Paris he first entered the college of Sainte-Barbe, and took his degree of Master of Arts in 1494. He next entered the college of Montaigu, the great stronghold of scholastic studies in the university of Paris, and in 1505 became Doctor of Theology. While continuing to reside in Montaigu he gave lessons in the scholastic logic and philosophy in the college of Navarre, and in those studies gained a reputation second to that of no teacher in Paris, and therefore in Europe. Besides teaching, Major wrote voluminous commentaries on Peter Lombard, which, though among the famous books of their time, were wholly out of touch with the true intellectual and religious movements of the 16th century. To this period of his life also belongs his combined history of England and Scotland, written in mediæval Latin, but still of real value as a record of facts, and by reason of the independent judgment of its author.

In 1518 Major was regent or teaching in the college of Glasgow, where he had John Knox among his pupils. In 1523 he left Glasgow for St Andrews, where he acted as regent in Arts at the *Pædagogium* of that university till 1525. At St Andrews he had among his students Patrick Hamilton, and likewise George Buchanan, who spoke of him as 'teaching the art of sophistry rather than dialectics.' Leaving St Andrews in 1525 Major again returned to Paris, where he remained till about 1530, admired and honoured by all who still maintained the traditions of the university as opposed to those who were eager

for the introduction of the new lights of the Renaissance. In 1533 he was appointed provost of St Salvador's College, St Andrews, an office which he held till his death in 1550. Of his last years nothing is known; though it is worthy of mention that in 1547 he was present in St Andrews parish church at the first public sermon preached by his former pupil John Knox, then completely identified with the cause of religious reform in Scotland.

Major was the most famous literary Scotsman of his generation, and as the acknowledged champion of mediævalism was assailed by men of such diverse character and aims as Melancthon and Rabelais. It was his misfortune that his life was mainly given to the advocacy of ideas which were already doomed by the new teachings of the revival of learning. Though born after Erasmus, with whom he was a contemporary in Paris, he yet remained dead to those influences of the Renaissance which made Erasmus the life-long foe of Montaigu and the Sorbonne. Nevertheless, by his great reputation in his own day, and by the strong individuality stamped on those of his writings which still have a certain interest, Major claims a far higher place than has yet been accorded him in the literary history of his country. See Mr A. Constable's translation of his *History* issued by the Scottish Historical Society (1892), in which full information is given regarding Major and his works.

Majorea, or MALLORCA, the largest of the Balearic Isles (q.v.), lies about 100 miles from the Spanish coast, and 150 N. of Algiers. It is 60 miles long by 40 broad, and 1310 sq. m. in area. The climate is healthful, the sea-breeze preserving a nearly equal temperature over the whole island. In the north there are mountains reaching 3500 to 5000 feet in height. The hillsides are terraced; olive groves abound everywhere, and almond, orange, fig, and other fruit trees are common. The vine is grown and good wine made. The soil is extraordinarily fertile, and is cultivated with marvellous patience and skill by the inhabitants, 233,650 in number, who manufacture cloth, cotton goods, ropes, silk, soap, shoes, &c., and have a trade to and from Spain of the annual value of £1,410,000. There are railways (total 48 miles) connecting the capital, Palma (q.v.), with Manacor (15,000), the second town of the island (where as well as at Arta there are magnificent caves), and La Puela (5000). Between this town and Alfindia, the port for Minorca and Barcelona, lie the marshes of Albufera (5000 acres), drained by a London company in 1865-71, and now of extraordinary fertility. Raymond Lully was born at Palma; at Valdemosa George Sand resided in 1838 and wrote her *Spardion*; and the beautiful seat of the Austrian Archduke Ludwig Salvator is at Miramar. Large quantities of lusted ware (Majolica, q.v.) were exported to Italy and elsewhere in the 15th century; this ware is still made to a small extent. Many of the nobles have handsome palaces in the island.

See Bidwell's *Balearic Isles* (1876); the sumptuous *Balearia in Wort und Bild* (5 vols. 1869-84), anon., but by Archduke Ludwig Salvator; and G. W. Wood, *Letters from Majorca* (1889).

Majority is the age at which a person acquires the status of a person *sui juris*—i.e. is able to manage his or her own affairs. This age in the United Kingdom is twenty-one. Under that age persons in England and Ireland are called infants, and are more or less subject to guardians, who manage for them their property. See INFANT.

Majuba Hill, situated in the extreme north of Natal, was the scene of the defeat of 648 British troops, with the loss of their leader, Sir George Colley, by a greatly superior force of Transvaal

Boers on 27th February 1881. The night before, after an eight hours' climb, they had occupied the hill, which overlooked the enemy's position at Laing's Nek, and which towards noon was unexpectedly carried by a rush of the Boers. Their loss was 1 killed and 5 wounded; of the British, 85 killed and 122 prisoners (many wounded), besides some missing. See Sir W. Butler's *Life of Colley* (1899).

Makart. HANS, Austrian painter, was born at Salzburg on 28th May 1840, studied under Piloty at Munich (1861-65), and after visiting Italy settled in Vienna in 1869. Ten years later he was appointed professor at the academy in the Austrian capital, and there he died on 3d October 1884. He painted grandiose spectacular and historical genre pictures, gorgeous with colour and of gigantic size; but the drawing and modelling were frequently faulty, and the treatment nearly always sensuous and voluptuous to a degree. Another strong characteristic of his work is a love for lifeless forms, with the look of death and of the grave upon them. His brilliant colouring and generally theatrical style of art made his pictures fetch large sums. Amongst the most notable specimens of his brush are 'Amorettes,' 'Entrance of Charles V. into Antwerp'—the nude female figures in which were portraits of well-known Viennese ladies (a fact that gave rise to much scandal)—'Cleopatra on the Nile,' 'The Five Senses,' 'The Seven Deadly Sins,' 'Diana hunting,' 'Summer,' and 'Spring.' See *Life by Von Lützow* (1886).

Makkari. AHMED EL., Moorish historian, was born at Makkara near Tlemcen, in Algeria, about 1585, travelled in Morocco, and in 1618 made the pilgrimage to Mecca. This he subsequently repeated five times, besides seven pilgrimages to Medina, and two to Jerusalem. At Damascus he created an enthusiastic impression by his preaching in 1627. His chief residence, however, was at Cairo, where he died in 1631.

His principal work was his *History of the Mohammedan Dynasties of Spain*, partly translated into English by Gayangos (2 vols. 1840-43), and edited by Dozy, Wright, and others under the title of *Analectes sur l'Hist. et la Litt. des Arabes d'Espagne* (Leyden, 1855-61, and also printed at Bülak, 1862). See Wustenfeld, *Die Geschichtschreiber der Araber*.

Mako, a market-town of Hungary, on the Maros, 19 miles ESE. of Szegedin. Pop. 30,063.

Makololo, a tribe of Basutos (q.v.) who, under their chief Sebituane and his son Sekeletu, founded an extensive kingdom in the basin of the Upper Zambezi; but a successful rebellion by the conquered tribes broke up the kingdom in 1864, since which time the Makololos have ceased to exist as a people.

Makrizi. TAKI-ED-DIN AHMED EL., the most eminent of the Arabic historians of Egypt, was born 1364 A.D. at Cairo, but derives his surname from his family's residence at Makriz, a suburb of Baalbek in Syria. He studied theology and jurisprudence under the best teachers; made the pilgrimage to Mecca in 1385; and held various official posts, as secretary of state, inspector of the markets (1398), preacher, reader, and lecturer at several mosques and colleges at Cairo, and (1408) curator of the Kalansiya and the Nuriya hospital at Damascus. Returning to Cairo, he devoted himself to the historical studies which have made him renowned, and after a second pilgrimage to Mecca (1430-35) he died at Cairo in 1442 at the age of seventy-eight.

He wrote sixteen works, besides smaller memoirs, of which the following are the most important: *The Khitat, or History and Topography of Egypt and Especially Cairo*, printed at Bülak (2 vols. 1853), but never completely translated, a work of the highest importance to

historians and archaeologists; a general history from 1181 to 1440, of which a part has been translated by Quatremère as *Histoire des Sultans Mamlouks* (2 vols. 1837-44); biographies of famous men who lived in Egypt, unfinished and unpublished; a treatise on Mohammedan coins, translated by De Saey (1797), and another on Mohammedan weights and measures, edited by Tychsen (1800); *History of Hadramaut*, edited by Noskowsky (1866); *Arab migrations to Egypt*, edited by Wustenfeld (1847); the Mohammedan kings of Abyssinia, edited by Rink (1790). See De Saey, *Christ. Arabi*, i. 112; Wustenfeld, *Die Geschichtschreiber der Araber*.

Malabar, a district (5765 sq. m.) on the south-west coast of India, in the Presidency of Madras, extending from 10° 15' to 12° 18' N. lat. Pop. (1891) 2,652,565, over two-thirds Hindus, and one-fourth Mohammedans. The surface is occupied in the east by the Western Ghats, which send down numerous rivers to the coast, many of them navigable for some distance. There are large forests. Rice is the staple crop; cocoa nuts are largely grown, and also coffee and pepper. The name of this district is applied to the whole south-western coast of Southern India.

Malacca, or MALAY PENINSULA, anciently known as the GOLDEN CHERSONESE, the long strip of land extending from Indo-China south and south-east towards Sumatra. The peninsula begins geographically at the head of the Gulf of Siam, and thus includes part of Siam proper and the British province of Tenasserim in Burma; but it is usual to limit the name to the portion south of the river Pakshan, the frontier of Tenasserim. In the larger sense Malacca extends from 13° 30' to 1° 16' N. lat., and its area is 75,000 sq. m., of which 40,000 belong to Siam, and the remainder to the Straits Settlements (q.v.) and their dependencies, the protected states. The width varies from 44 miles at the isthmus of Kra (q.v.) to 210 at Perak. The interior consists mainly of magnificently-wooded mountain-ranges, disposed parallel to the long axis of the peninsula, some of whose peaks attain a height of 6000 to 7000 feet (Mount Riam is at least 8000 feet), while along the coast there are mangrove swamps, half-a-dozen miles deep, backed by low fertile plains reaching to the mountains. Amongst the more valuable of the trees are ebony, camphor, teak, sandalwood, cinnamon, rattan, cocoa, areca, and other palms, nutmeg, &c. The rivers are short and of little use for navigation. A double belt of islands runs along parts of both coasts. The peninsula is the richest tin-yielding region in the world (see TIN). The tin ore occurs in conjunction with gold and silver, both extracted; iron and coal exist, the former in great quantity, but neither mineral is worked. The forests and mountains shelter numerous varieties of wild animals, as the tiger, rhinoceros, tapir, elephant, hog, buffalo, monkeys, &c., and many beautiful birds. The climate is pretty uniform all the year round. The low districts are hot and moist, and neither they nor the highlands are healthy for Europeans. Rain falls on 190 days in the year. The thermometer ranges from 70 to 90 F. Pop. 1,200,000-800,000 in British territory and dependencies. They are mainly Siamese in the north, civilised Malays (q.v.) along the coast and in the south, and uncivilised Malays, mixed with aboriginal Negrito tribes, in the interior. The crops chiefly cultivated are rice, sugar cane, cotton, tobacco, yams, latata, and cocoa and areca nuts. Politically, Siam extends as far south as 5° 30' on the west coast, and to 4° on the east coast, and includes the tributary states of Ligor, Senggora, Patani, Kelantan, Tringgama, and Kemaman. The southern portion embraces the British settlements Penang, Malacca, and Singapore, all treated in separate articles, and the protected states Perak, Selangor, Sungei

Ujong, the Negri Sembilan states, Pahang and Johore, for which see JOHORE and STRAITS SETTLEMENTS; Mrs Bishop's *Golden Chersonese* (1883), Keane's *Malay Peninsula* (1887), and Guillemaud's *Malaysia* (1895); and Rathborne's *Camping in Malaya* (1898).

Malacca, part of the Straits Settlements, is situated on the south-west coast of the Malay Peninsula, 100 miles from Singapore, and is 42 miles in length, and from 8 to 25 broad. Area, 659 sq. m.; pop. (1891) 92,170. The coast-lands are flat and swampy, and produce rice; inland there are low hills. Besides rice, the chief products are tapioca, pepper, fruits, &c. Tin is mined and exported. Tapioca is the only other export of value. The imports average £610,000 annually, the exports £570,000 approximately. The mean annual rainfall varies from 68 to 91 inches. The town of Malacca, capital of the settlement, is situated in 2° 1' N. lat., 102° 14' E. long., at the mouth of a small river, and consists of the old Dutch or European town and the Chinese and Malay town on the other (left) bank of the river. The church of Our Lady dei Monte was the scene of the labours of St Francis Xavier. Pop. 20,000.

Malacca was taken by the Portuguese under Albuquerque in 1511, and flourished as one of the great emporiums of Indo-China; but it was subsequently supplanted by Penang, and Penang by Singapore. Malacca became a Dutch possession in 1641, and fell in 1795 into the hands of the British, who restored it to the Dutch in 1818; but they returned it to Britain in 1824.

Malacca, STRAIT OF, separates the Malay Peninsula on the north-east from the island of Sumatra on the south-west, and connects the Indian Ocean with the Chinese Sea. Length, 480 miles; breadth, varying from 30 miles at the south-east to 115 miles at the north-west extremity. On this strait are the British settlements of Malacca, Penang, &c.

Malachi (probably an abbreviated form of *Malachiyyah*, meaning 'messenger of Jehovah'; the LXX. and Vulgate have *Malachias*), the name given to the last book in the prophetic section of the Old Testament canon. Regarding its author nothing is known. It has even been doubted whether Malachi is a proper name or only an appellative ('my messenger' or 'Angelicus'), many authorities both in ancient and in modern times favouring the latter view, and thinking that some such writer as Ezra, or even some supernatural person is meant. But although Malachiyyah does not actually occur anywhere in the Old Testament, there is nothing to make it impossible as a proper Hebrew name. The book consists of a series of reasoned remonstrances against prevailing laxity in religious and social conduct, the points brought chiefly into prominence being the bringing of defective offerings to the altar, irregularity and evasion in payment of tithes, mixed marriages and unjustifiable divorces, a spirit of scepticism as to the divine cognisance of human actions and as to the reality of moral distinctions, the practice of witchcraft, sovery perjury, oppression. Warning is given of the approaching judgment, when Jehovah himself, preceded by the angel of the covenant, shall come to cleanse the sinful community by the removal of those who have been found unfaithful. It is the priests who are primarily addressed, and the community which they lead is that of 'Judah and Jerusalem'; both circumstances, combined with the reference to the pasha or governor, show that the prophecy belongs to the Persian period. Some have assigned it to the governorship of Nehemiah, but in view of Neh. v. 14 *seq.* this is improbable; its date is to be sought rather in the interval

between his two terms of office, or after the close of the second—possibly many years after. It is usual to speak of the style of Malachi as marking the transition from the age of the prophets to that of the scribes, as having little of the freedom and fire of the older period, and as tending to the artificiality of formal scholastic disputation. Yet its dialogue is not without dramatic force; and relatively to its size the little book has contributed an unusually large number of memorable phrases and bold and striking figures to the language and thought of Christendom. For commentaries on Malachi, see the works on the minor prophets mentioned under HOSEA. There are monographs by Poccoek (1677), Reinke (1856), Koehler (1865), Sanger (1867), Lange (1876), and Pusey (1877).

Malachite, a mineral, essentially a carbonate of copper, of a green colour, occurs generally massive, with a globular reniform, botryoidal or stalactitic surface; frequently fibrous and showing irregular bands of colour; sometimes earthy in texture. More rarely it is met with crystallised in rather oblique four-sided prisms, bevelled on the extremities, or with the bevelling planes truncated so as to form six-sided prisms. It is valuable as an ore of copper, although seldom smelted alone, not only because it is found along with other ores, but because the metal is apt to be carried off with the carbonic acid. It is sometimes passed off in jewellery as turquoise, although easily distinguished by its colour and much inferior hardness. It is used for many ornamental purposes; slabs of it—chiefly from the mines of Siberia—are made into tables, mantel-pieces, &c. of exquisite beauty. In 1835 a mass of solid malachite was found in the Ural Mountains of more than 17 feet in length, and weighing about 25 tons. By the ancients it was used as a charm to protect infants from witchcraft and sorceries.

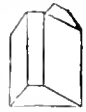

Crystal of Malachite.

Malachy, ST. Archbishop of Armagh, and the greatest of St Patrick's successors, was born about 1095 at Armagh, and was brought up at the university or school there under the anchorite Inar. About 1119 he received orders, and went to study theology at Lismore, where he was confirmed in his preference for the Roman over the old Celtic system. In 1121 he became abbot of Bangor. Archbishop Celsus, who had made him his vicar, procured his election to the see of Connor (1125), and on his deathbed (1129) recommended him as his successor in the primacy. It was not, however, till 1134 that Malachy could establish himself therein, and, that done, he withdrew three years later to the see of Down, though retaining the virtual headship of the Irish Church. In 1140 he journeyed to Rome, seeking the pallium, and Innocent II. appointed him papal legate for Ireland. On his way out, and again on his way back, he visited St Bernard at Clairvaux, and returned to Ireland (q.v., p. 210) with four Cistercian monks. In 1148 he once more repaired to France, to renew to Eugenius III. his request for the pallium; but before his arrival the pope had gone back to Rome, and at Clairvaux, on All Saints' Day, 1st November, Malachy died of a fever in St Bernard's arms. He was canonised by Clement IV.

The curious 'Prophecies of St Malachy' were first published in his *Lignum Vitæ* (Venice, 1595) by the Flemish Benedictine, Arnold Wion, who deemed them a recent forgery. They consist of 111 Latin mottoes, forecasting as many pontiffs from 1143 to about 1996. The first 74 (down to 1590) are 'almost without exception,' says Lord Bute, 'transparent indications of the individuals

to whom they apply. In the case of Urban VI. the very family name, Pagnani, is given (*De inferno Pagnani*); and the overwhelming majority of the others are simple puns or plays upon the Christian name, the origin or native place, the previous employment, or the coat-of-arms. The last are extremely frequent, though—unless to a prophet—Heraldry (q.v.) was unknown in 1413. The thirty-seven forecasts after 1590, as a rule, are strangely vague in contrast to their predecessors, and have sorely taxed the ingenuity of students of prophecy. Still, it cannot be denied that there are a few good shots—none better than *Rastrum in portâ* ('the rake at the gate') for Innocent XII. (1681), who was one of the Pignatelli of Rastello at the gates of Naples. Then *Peccariâs Apostolicus* fits nicely for Pius VII., and *Aquila rapax* for Pius VIII., carried off to France by Napoleon, whose emblem was an eagle. For Pius IX. the motto was *Cœus de cruce*, and *Lumen in Cœlo* for Leo XIII., his arms bearing a fiery star. The nine prophecies still unfulfilled in 1890 were *Ignis ardens*, *Religio depopulata*, *Fides interrita*, *Pastor angelicus*, *Pastor et navita* (this shepherd will belike make a voyage), *Flos florum*, *De medietate lunæ*, *De labore solis*, and *Gloria olivæ*. After which 'the City of the Seven Hills shall be destroyed.'

See St Bernard's *Vita Malachie* (in Migne's *Pate. Cursus*, clxxi. 1074); Prof. G. T. Stokes's *Lecland and the Celtic Church* (2d ed. 1888); and, for the 'Prophecies,' Moreri's *Dict. Historique* (ed. 1759); vii. 117, and an admirable article by the Marquis of Eute in the *Dublin Review* for October 1885.

Malacology (Gr. *malakos*, 'soft'), a name sometimes employed to designate that branch of natural history which has *molluscs* (called *malakia* by Aristotle) for its subject. See MOLLUSCA.

Malacopterygii ('soft-finned'), a term applied by Cuvier to those Bony Fishes (q.v.) in which the dorsal fins are supported by soft, jointed rays.

Malaga, a seaport in the south of Spain, is situated on the Mediterranean, 65 miles N.E. of Gibraltar. Sheltered on the north and east by mountains, and with a wonderfully equable and uniform climate (range of thermometer 56° to 82° F.), of which dryness and constant sunshine are the characteristics, this place is superior as a resort for invalids to any either in France or Italy, not excepting the Riviera. The only noteworthy buildings are the cathedral (1528-1765), which is still unfinished, and the Moorish castle, built in the end of the 13th century on the site of a former Phœnician stronghold. Malaga is one of the most important commercial seaports of the kingdom. Yet its trade has been rapidly declining since 1878. Diseases have ravaged the vines and the orange and lemon groves; and heavy octroi duties, unscientific methods of agriculture and of extracting olive-oil, and insufficient and expensive means of communication have all contributed to cause the depression. Nevertheless, olive-oil, wine, raisins, lead, almonds, lemons, grapes, chick peas, and esparto grass are exported to the annual value of £1,953,000, and cotton, timber, coal, petroleum, sugar, and codfish are imported to the annual value of £474,000. The United States, the great customers for Malaga raisins, now use California raisins instead; the export of raisins from Malaga to the States has consequently decreased from 1,000,000 boxes in 1882 to a few thousands in 1895. The harbour, which is entered by 2400 vessels of 1,025,000 tons annually, one-sixth being British and three-fourths Spanish, is protected by two large moles. The manufacturing industry is more hopeful and energetic; it includes establishments for making cotton and linen goods, machinery, fine art pottery, flour, soap, lithographed work, and

wine and oil presses. Pop. (1887) 134,016. The *Malaca* of the Romans, the town is a very ancient place, having been founded by the Phœnicians. It was an important city under the Moors, being first subject to Cordova and afterwards to Granada, from the conquest of Spain early in the 8th century down to 1487, when it was captured by Ferdinand and Isabella.—The modern *province* of Malaga has an area of 2836 sq. m., and a pop. (1887) of 523,627. One-sixth is planted with the vine, and two-fifths yield wheat, barley, and maize. Lead, iron, and manganese are mined.

Malagasy. See MADAGASCAR.

Malakoff. See SERASTOPOLE.

Malan, CESAR HENRI ABRAHAM, a Protestant Swiss divine, was born in Geneva, 8th July 1787, and became a pastor of the state church and a regent in the college. Through the influence of American and Scottish friends, he became devoutly evangelical, and many of his works were translated into English—*The Church of Rome* (1844), *Stories for Children* (1852), *Pictures from Switzerland* (1854). Both words and music of *Chants de Zion* (1826) are his own. He died 8th May 1864. His *Life* was written (1869) by his son Solomon Cesar, D.D. who, born at Geneva in 1812, studied at Oxford, and was vicar of Broad Windsor and prebendary of Sarum. He wrote on birds, and several theological works, and died 27th November 1894. See *Life* by his son (1897).

Malaprop. Mrs. a character in Sheridan's *Receils*, whose remarks are not so much out of place or *mal-à-propos*, as ingeniously perverse in 'derangement of epitaphs'—i.e. in confounding and misapplying words somewhat similar in sound or spelling—a 'Derbyshire putrefaction,' 'a barbarous Vandyke,' 'an allegory on the banks of the Nile.'

Malapterurus. See ELECTRIC FISHES.

Mälär, LAKE, one of the largest lakes, and the most beautiful, in Sweden, measures 80 miles in length from east to west, and has numerous long narrow arms and offsets; area, 650 sq. m. It is studded with upwards of 1200 islands, mostly well wooded. Its east end is close by Stockholm, where its waters are poured into the Baltic Sea. The shores are very varied with bays and hills, woods, lawns, and cliffs, and are adorned with many castles, country-seats, and villas, including the royal palaces of Drottningholm and Gripsholm.

Malaria, or Miasm. Malaria, an Italian word, is almost universally employed to designate an earth-born poison which is generated in soils the energies of which are not expended in the growth and sustenance of healthy vegetation. This emanation gives rise to certain diseases, especially the various forms of intermittent and remittent fever. During the past three hundred years some two thousand books and papers have been written upon the subject, but as yet, although much is known of malaria, it is impossible to state definitely what the morbid agent really is. Many theories have been advanced with regard to malaria. It has been said to be due to a parasite, to a germ, to some telluric origin which the French call telluric intoxication, to the toxic excretions of living organisms, plant or animal. Some say it is caused by chill, others by certain electrical conditions of the atmosphere, and others say it is due to a gas emitted from marsh water. Although malaria is so often connected with marshy districts as to lead many to suppose that a marsh must be inseparably connected with its production, yet we find that, although it is most powerful near marshes, it is also found in arid regions and in rocky districts which are in a state of disintegration. Its geographical distribution is very wide, but it is most

virulent in tropical and subtropical regions. Its dependence on climatic influences is shown by the prevalence of malarial fever at certain seasons and under certain meteorological conditions; even in those districts where malaria is endemic throughout the whole of the year there is a maximum and minimum period to its virulence. It is certain that a high temperature is capable of increasing the frequency and severity of malarial fever; and that in those places where the summer temperature is from 58° to 60° F. the production of the poison is prevented. The influence of the rainfall varies with the character of the soil. As a general rule it may be said that the malarial poison is most virulent either when the rains set in after a long period of heat, or when the rains cease and give place to warm dry weather. The virulence of the poison is notably diminished at the height of the rains if they are very abundant, but the poison is produced in greater quantities in wet than in dry years. Wind exerts a certain influence upon malaria, for it can carry the poison from a marsh to a healthy spot, probably to the distance of three miles; wind also prevents the vertical ascent of the poison, for in calm air malaria may ascend to 700 or 1000 feet above a swamp, but should a strong wind be blowing this vertical diffusion is prevented. It is also probable that on some islands where malaria is absent, although from analogy we should expect to find it present, the wind by rapidly changing the atmosphere carries away the poison before it has time to do harm. The extent and severity of malarial diseases diminish as one ascends above sea-level. The height at which malaria is produced depends upon climatological conditions—i.e. in tropical districts one must ascend to a greater altitude to find a situation free from malaria than would be necessary in a northern climate. In the tropics an altitude of 3200 feet may be required to prevent the production of malaria, whereas in the Apennines 1500 feet only is required, and farther north malaria is not found at a greater altitude than 500 feet. In investigating the occurrence of malaria in non-mountainous regions we also find that altitude plays a not unimportant part, for even on a level plateau with basin-like depressions the deepest points are those most affected by disease, and in those exceptional cases where malaria is endemic at more or less considerable elevations the seat of the production of the poison is invariably in a valley or ravine. The older geological formations are more or less exempt in proportion to the compactness of the rock and the porosity of the soil, and accordingly the alluvial and diluvial formations are the chief seats of endemic malaria. Clay, marl, and marsh lands are most favourable to its production; a porous chalky soil is less favourable, and sandy soil least favourable to its production. Where malaria is endemic in rocky districts there is always a more or less thick layer of permeable alluvial, diluvial, or mineral detritus spread over the firm rock, and invariably a hygroscopic upper soil.

Whatever the character of the soil, a copious saturation of the ground is necessary for the production of malaria. This may be caused by atmospheric precipitations, drainage from rivers, lakes, or pools, inundations, either periodic or irregular, irrigation, and saturation of the ground with subsoil water. The amount of organic matter in the soil is certainly connected with the production of malaria, and, other circumstances being equal, the greatest amount of malaria will be found where the amount of organic matter in the soil is greatest, least where it is least. Changes in the soil indicate clearly its influence on the production of malaria, for the latter will

disappear on damp or marshy soil being completely dried up. If water completely covers the soil, malaria disappears; if virgin land be reclaimed, it proves malarious until perfectly cultivated, and a neglect of once cultivated ground may also produce malaria. It has been found by experience that malaria is not produced in the centre of cities, and, although it may be prevalent in the outskirts of large towns, it does not penetrate to their centres.

Laveran discovered the parasite of malaria; Bignami, Grassi, and others insisted (1899) that the malady was mainly communicated by mosquitoes; and Major Ross made extensive researches in West Africa into the theory, singling out the *Anopheles gambiae* as especially active. Professor Koch's investigations (1899-1900) in Italy, Java, and New Guinea prove that the true home of the germ is in the blood of the malarial patient; mosquitoes and other gnats, imbibing the germ in stinging a sufferer, introduce it into the blood of the next person stung. In New Guinea nearly all children are afflicted with malaria. Much may be done to combat the disease by special attention to children, and to mild and latent cases in adults. In Germany cases of malaria in the army, which in 1865 were 13,500, were in 1895 only 230; doubtless owing to the free use of quinine. Ross insists on the possibility (denied by Koch) of exterminating mosquitoes by surface drainage. Dr Sambon and Dr S. Low, who were commissioned by the British Government, spent the malarial season (July to October) of 1900 in the worst parts of the Roman Campagna; they found that people who only go about during the day, when these insects do not appear, and who protect themselves from them at night, when they are abroad in myriads, do not suffer from malaria; whereas the sting of a mosquito was invariably followed by the disease. See ENDEMIC and the monograph by Celli (trans. 1900).

Malatia (anc. *Melitene*), a town in the province of Diarbekir in Asia Minor, 8 miles from the Euphrates; pop. 20,000.

Malay Peninsula. See MALACCA.

Malays, the dominant native race in the Eastern Archipelago and neighbouring Asiatic peninsula, which from them are commonly named respectively the Malay Archipelago and Malay Peninsula, and collectively Malaysia. Physically the Malays must be regarded as an oceanic branch of the Mongolic division of mankind, diversely modified by interminglings, especially with dark (Papuan) elements in the eastern, and light (Caucasic) elements in the western and central parts of the archipelago. The former (*Malayo-Papuan*), often designated by the somewhat vague term 'Alfuro,' merge gradually eastward through Timor, Ceram, and South Jilolo in the true Papuans of Aru and New Guinea. The latter form two distinct groups, the *Indonesians* showing more of the Caucasoid, and the *Malays proper* showing more of the Mongolic element. The Indonesians, represented chiefly by the Battaks and Kubus of Sumatra, the Bughis and Mangkassaras of South Celebes, the Buled Upihs and others of Borneo, the Manobos and Tinguians of the Philippines, the Mentawey islanders (west coast of Sumatra), and many of the tribes in the Moluccas (North Jilolo, Bnn), are of medium and even tall stature, well proportioned, with light brown complexion, long (dolichocephalic) head, straight eyes, large nose, and regular features. The Malay race proper comprises all the rest of the inhabitants of Malaysia, except the Negritos of the Philippines and Malay Peninsula; also the Chams of the south-eastern extremity of Cochinchina, many of the Formosan tribes, the Hovas of Madagascar, and some of the Micronesian islanders.

They are of low size, averaging little over five feet, with yellowish complexion, straight black hair, round (brachycephalic) head, somewhat almond-shaped eyes, small nose, high cheek-bones, flat features, small hands and feet, in general so like the east Asiatic Mongols that Chinese dressed as Balinese could scarcely be distinguished from Malays, while many natives of Java might pass very well for Chinese (Wallace).

But linguistically the Malays are entirely severed from the Asiatic Mongols, all the Malay languages without exception belonging to the widely diffused Malayo-Polynesian family, which extends across the Indian and Pacific Oceans from Madagascar to Easter Island, and from New Zealand northwards to Hawaii. This area includes many dark populations, such as the natives of the New Hebrides and Solomon Islands, who speak primitive or archaic forms of the organic Malayo-Polynesian tongue, of which the standard Malay, Kavi, Javanese, and other idioms of the more cultured Malay peoples appear to be later developments (Codrington). Thus in the oceanic world race and language are, so to say, antagonistic, and present many difficult problems, the solution of which must await further research.

The peoples of standard Malay speech—i.e. the Malays in the narrower and popular acceptance of the term—occupy a comparatively limited portion of Malaysia, being mainly confined to the Malay Peninsula to about 9° N. lat., the southern provinces of Sumatra (Menangkabo, Palembang, &c.), Lingen, Banca, and the other islands between Sumatra and Borneo; Banjarmassin, Pontianak, Brunei, and some other maritime districts in Borneo; Tidor, Ternate, and the Banda group in the Moluccas, and the Sulu Islands. But at all events since the 13th century these Malays have been the chief trading people of the archipelago, where their language was already the general medium of intercourse throughout Malaysia at the arrival of the Portuguese towards the close of the 15th century. The question of their origin has been much discussed, some fixing the cradle of the race on the Asiatic mainland, others in Sumatra. This island, and especially Menangkabo, was undoubtedly the point of dispersion of the later historic migrations both to the mainland and to the eastern parts of the archipelago, which migrations can be traced back to the 12th century. But the race itself, being a branch of the Mongolic stock, must have originally reached the islands from the mainland, where the *Orang-Benua* ('men of the soil'), indigenous Malay tribes, are still found almost at as low a stage of culture as their Negrito neighbours. Others, the so-called *Orang-Laut* ('men of the sea'), have from times long anterior to the Sumatran migrations been scattered over all the inland waters of the archipelago, 'a vile people, living by fishing and piracy' (De Barros). Lastly, the *Orang-Melayu* themselves—i.e. the civilised Malays, formerly Brahmanists and Buddhists, now mostly Mohammedans—had already overrun the southern parts of Annam in the 8th century, and the Hovas had reached Madagascar at a still earlier epoch—i.e. before the spread of Hindu influences in the archipelago, for there are no Sanskrit words in the Malagasy language. Hence the Menangkabo dispersion can only be regarded as an episode in the history of the Malay race, whose origin must be sought, not in Sumatra, but in the Indo-Chinese peninsula. Their connection with the primitive inhabitants of this region is also shown by numerous practices, such as pile building, head hunting (Dyaks of Borneo), certain matriarchal customs, a dislike of milk, and fondness for putrescent fish, large ear ornaments, cock-fighting and other forms of gambling.

Of late years the Malays have mostly abandoned their lawless roving habits, and are now spoken of as a somewhat mild, patient, and taciturn people, occupied chiefly with trade and agriculture, and distinguished especially for their extreme courtesy towards each other and strangers. But the old fiery spirit still smoulders beneath an apparently passive exterior, and too frequently reveals itself in those sudden outbursts of murderous frenzies known as 'running amuck.' The Malay intellect is of a low order, and the race has never developed a native culture, their civilisation being entirely due to foreign influences, chiefly Hindu and Arab. The Malay language, which is soft and harmonious and of simple structure, is written in the Arabic character, which is ill suited for the purpose. Lately the Roman system has been largely adopted, especially in the Dutch and English dependencies. The literature, which is copious, comprises poetical compositions, such as rhyming proverbs, love-songs, and dramas displaying some originality, but little imagination. The prose-writings (histories and chronicles in which truth and fiction are inextricably interwoven, treatises on law, theology, and ethics) are mostly based on Arab or Persian models.

See J. Crawford, *History of the Indian Archipelago*; Logan, *Journal of the Indian Archipelago and East Asia*, and *Ethnology of the Indian Archipelago*; A. R. Wallace, *The Malay Archipelago*; T. J. Newbold, *Account of the British Settlements in the Straits of Malacca*; W. E. Maxwell, *Manual of the Malay Language*; Miklukho Maclay, *Ethnological Excursion in Johor*; A. H. Keane, *Relations of the Indo-Chinese and Inter-Oceanic Races and Languages*; Von Rosenberg, *Die Malayische Archipel*, and *Folklore of the Malays*; *Journal of the Straits Branch of the Royal Asiatic Society*.

Malcolm, SIR JOHN, G.C.B., a British soldier, statesman, and historian, was born at Burnfoot, near Langholm, Dumfriesshire, May 2, 1769, and at fourteen went to India as a cadet in the Madras army. In 1798 he was appointed assistant to the resident at Hyderabad by Lord Wellesley. He distinguished himself at the siege of Seringapatam in 1799, and in 1800 he was sent as ambassador to Persia, to form an alliance with that country against Bonaparte, in which he succeeded. In 1801 he acted as private secretary to Wellesley; in 1803 was appointed governor of the Mysore Residency; and during the next two years did much to reduce to order and tranquillity the newly-conquered Mahratta states. In 1807 and 1810 he was again sent as minister-plenipotentiary to the Persian court. In 1812 he returned to England, received the honour of knighthood, and, after five years, went out again to India as the governor-general's political agent in the Deccan, and with the rank of brigadier-general in the Indian army; in the latter capacity he greatly distinguished himself in the wars against the Pindaris and Holkar. He was again in England in 1822, and settled with his family at Hyde Hall, near Sawbridgeworth, Hertfordshire. To this period belong his anonymous *Sketches in Persia* (1827). Governor of Bombay (1827-30), he entered parliament in 1831 as member for Lauceston, and opposed the Reform Bill. He died of paralysis in London, 30th May 1833. The Duke of Wellington in 1824 wrote to Malcolm that from the year 1796 'no great transaction has taken place in the East in which you have not played a principal, most useful, conspicuous, and honourable part.' Malcolm's writings are *A History of Persia* (2 vols. 1815; 2d ed. 1828), *Memoir of Central India* (2 vols. 1823), *Political History of India from 1783 to 1831* (2 vols. 1826), and *Life of Lord Clive* (1836). See his *Life and Correspondence*, by Kaye (1856).

Malcolm Canmore (Clak, *Cannmore*, 'great head'—king of Scotland, was a child when in 1040

his father, King Duncan, was slain by Macbeth (q.v.). He seems to have spent his youth in Northumbria with his uncle, Earl Siward, who in 1054 established him in firm possession of Cumbria and Lothian. In 1057, on the death of Macbeth and (seven months later) of Lulach, as well as that probably of Earl Thorfinn of Orkney, he ascended the throne of all Scotland. For the first eight years he was free to devote his energies to the consolidation of his kingdom, England then being ruled by the peaceful Edward the Confessor; but even during this period he made one raid into Northumbria (1061). And after 1066 the history of his long reign is one of ceaseless warfare with the Norman. His first wife, Ingibiorg, Thorfinn's widow, had died; and in 1069 Malcolm wedded Margaret, sister of Edgar the Atheling (q.v.), whose cause therefore he warmly made his own. Five separate times did he harry Northumbria, as far sometimes as York (1069, 1070, 1079, 1091, and 1093); and there were counter-invasions by William the Conqueror and Prince Robert, in 1072 and 1080, on the former of which occasions at Abernethy King Malcolm came and made peace with King William, and gave hostages and became his man. This homage he renewed to William Rufus in 1091; but, according to Scottish historians, it was only for Lothian and Cumbria, which once had belonged to England. In 1092 Rufus wrested from Scotland all Cumbria south of the Solway; and next year Malcolm gathered his army and marched into England, harrying with more animosity than ever beloved him. And then, on 13th November 1093, Robert de Mowbray, Earl of Northumberland, ensnared him at Alnwick with his men unawares and slew him. Morel of Bamborough, who slew him, was Earl Robert's steward and King Malcolm's gossip. With Malcolm, also, was slain his son Edward, who should, if he had lived, have been king after him. Malcolm left, however, five sons, of whom four succeeded him on the throne—Duncan (by Ingibiorg), Edgar, Alexander, and David. His reign is an important one, as the commencement of the transition of Scotland, Celtic and Culdee, to Scotland, feudal and Roman Catholic; but the change was not due to him so much as to his saintly queen.

See the article MARGARET, and Skene's *Celtic Scotland* (1876); and see the article SCOTLAND for the other three kings of that name—Malcolm, son of Donald, king of Alban from 942 to 954; Malcolm, son of Kenneth, king of Scotia from 1005 to 1034; and Malcolm the Maiden, king of Scotland from 1153 to 1165.

Maldegem, a town of East Flanders, Belgium, 12 miles by rail E. of Bruges. Pop. 8522.

Malden, a village of Surrey, 3 miles SE. of Kingston-upon-Thames. From 1264 to 1274 it was the seat of Merton College, so may claim to be the metropolis of Oxford. Pop. of parish, 525. The town of New Malden (pop. 2538) is 2 miles E. of Kingston, of which it is practically a suburb.

Malden, a town of Massachusetts, 5 miles by rail N. of Boston. There are manufactures of india-rubber goods, cords and tassels, sand-paper, &c. Pop. (1890) 23,031.

Malden Island, a British possession in the Central Pacific, lies NW. of the Marquesas in 4° 3' S. lat. and 155° W. long. It is a coral island 5 miles long by 1 broad, and has valuable deposits of guano, worked by eight Europeans and 160 native labourers.

Maldive Islands, a chain of characteristic Coral (q.v.) atolls in the Indian Ocean, lying SW. of Ceylon. They extend 550 miles in length (7° 7' N. lat. to 0° 12' S.) by 45 in average breadth (72° 30' to 73° 50' E. long.), and consist of seventeen

groups, distributed politically into thirteen, and embracing a total of several hundred islands. All of these are very small in area, and less than 200 are inhabited. Male, the residence of the native 'Sultan of the Twelve Thousand Isles,' is 1 mile long by $\frac{2}{3}$ mile wide, and contains a pop. of 2000. The population of the whole chain is probably not more than 20,000. These people resemble the Singhalese in their personal appearance, and speak a language closely akin to Singhalese. They are Mohammedans by religion, and boast of an ancient civilisation. They are peaceful, affectionate, well behaved, and of cleanly habits. Rice (imported), fish (chiefly bonito), bread-fruit, cocoa-nut, and various other fruits and vegetables are their principal food. Coir, cowries, dried bonito fish, cocoa-nut and copra, and tortoiseshell are exported. The gathering and preparation of these articles are the principal occupations, apart from a little weaving. The Arab geographer Ibn Batuta lived more than a year on the islands (1343-44). The Portuguese maintained factories there at various times after 1518; but in 1645 the sultan put himself under the protection of the Dutch governor of Ceylon, and along with that island they exchanged Dutch for English supremacy. The sultan sends an embassy every year, bearing presents, to renew his homage to the governor of Ceylon.

Maldon, a municipal borough of Essex, 9 miles E. of Chelmsford and 38 NE. of London (by rail 44), stands on a hill near the confluence of the Chelmer and the Blackwater, in the vicinity of which traces are still extant of a Roman encampment. It has two fine churches, partly Decorated and partly Perpendicular, and a quaint town or moot hall dating from the reign of Henry VI. The manufacture of crystallised salt is a speciality, and in the Blackwater—a noted resort of wild-fowl—are extensive oyster-fisheries. From 1328 to 1867 Maldon returned two members to parliament, and thence to 1885 one. Plume, founder of the professorship of Astronomy at Cambridge, General Gates, and J. R. Herbert, R.A., were natives, and Landseer's parents residents till 1815. In the battle of Maldon (991), the subject of a famous old English poem, the English under Brihtnoth were defeated by Norwegian Vikings under Guthmund and Olaf Tryggvason. Pop. (1801) 2358; (1881) 5468; (1891) 5397. See Fitch's *Maldon and the River Blackwater* (1895).

Malebranche, NICOLAS, a French philosopher, was born August 6, 1638, at Paris. He was deformed and sickly, and from his childhood fond of solitude. At the age of twenty-two he entered into the congregation of the Oratory, and devoted himself to the study of Patristics and church history, till Descartes's treatise, *De Homine*, falling into his hands, attracted him to philosophy. His famous work, *De la Recherche de la Verité* (3 vols. 1674; 6th ed. 1712), revealed great depth and originality of thought combined with perspicuity and elegance, its object being the psychological investigation of the causes of the errors to which the human mind is liable, and of the nature of truth and the way of reaching it. He maintains that we see all things in God, his famous *Vision en Dieu*; that all beings and thoughts exist in God—*Dieu est le lieu des esprits, comme l'espace est le lieu des corps*; and that God is the first cause of all changes which take place in bodies and souls, which are therefore merely passive therein. His system is a kind of mystic idealism. It was immediately opposed by Ant. Arnauld, Bossuet, and many others, and was subjected to a thorough and critical examination by Locke and Leibnitz. Other works of Malebranche's are *Traité de la Morale* (1684) and *Conversations*

Metaphysiques et Chrétiennes (1683), in the latter of which he endeavoured to exhibit the harmony of his philosophic views with Christianity. He died at Paris, October 13, 1715. The story of Stock, Berkeley's biographer, that Malebranche died of the excitement induced by a metaphysical discussion with the subtle Berkeley, is disproved by the dates; Berkeley having been in England from August 1714 till 1716.

An edition of his works, published in 1712, filled 11 volumes. Later editions are by Genoude and Lourdoux (1837) and Jules Simon (1850-71). See the Life by André (Tours, 1886), and the Studies by Blampignon (1861), Ollé-Laprune (1870), and Pillon (1895).

Male Fern. See FERN (MALE).

Maletuetta Pepper. See GRAINS OF PARADISE.

Malesherbes, CHRÉTIEN GUILLAUME DE LAMOIGNON DE, a distinguished French statesman, was born at Paris, December 6, 1721. Educated at the Jesuits' College, at twenty-four he became counsellor to the parliament of Paris, and in 1750 succeeded his father as president of the Cour des Aides, where he showed clear judgment, strict integrity, and humanity. A quiet but determined opponent of government rapacity and tyranny, he watched the ministry with a jealous eye, and was indefatigable in his efforts to prevent the people from being plundered. Besides his more proper judicial duties he was entrusted also with the censorship of the press, and so tolerant was he that French authors pronounce the period of his censorship 'the golden age of letters.' To his large mind we may ascribe the publication of the famous *Encyclopédie*. In 1771 his bold remonstrances against the abuses of law which Louis XV. was perpetrating led to his banishment to his country-seat of St Lucie, but here he solaced himself with botany, ever a favourite study. At the accession of Louis XVI. (1774) he was recalled, and took office under the crown, but retired on the dismissal of Turgot, and from this time to the Revolution spent his time in travel, or in the improvement of his estates, with one brief interval of office in 1787. The first storms passed him by; but when he heard that the unhappy king was about to be tried by the Convention he magnanimously left his retreat, and came to Paris to undertake his defence. 'I was twice called to the council of him who was my master, when all the world coveted that honour; and I owe him the same service now when it has become one which many reckon dangerous,' said the gray-haired hero. From that day Malesherbes himself was doomed. He was arrested in the beginning of December 1793, and guillotined, April 22, 1794, along with his daughter and her husband, brother of the famous Chateaubriand. Malesherbes was one of the noblest figures of his time, and his fearless, high minded devotion to duty as an advocate was fittingly commemorated in 1826 by a statue in the hall of justice at Paris, and in the name of a well-known boulevard in the city. He was a member of the Academy, and brought an able pen to the discussion of agriculture and botany as well as political and financial questions.

His *Œuvres Choësies* (1809) contains his most interesting writings. For his Life, see the books by Dubois (3d ed. 1806), Gaillard (1805), Bossy d'Anglas (1818), Rozet (1814), Dupin (1814), and Vignaux (1874).

Malet. See MALLET.

Malherbe, FRANÇOIS DE, was born at Caen, July 13, 1555. After studying at the university of Caen he attached himself to Henri d'Angoulême, a natural son of Henri II., and was afterwards pensioned by the Duc de Bellegarde. He joined the court of Henri IV., and received a pension of 1500 livres from the queen. He was an industrious

writer, producing odes, songs, paraphrases, epigrams, epistles, translations, criticisms, &c. He founded a literary school, and by his influence brought about a revolution in poetic style. He gave lessons in composition to a class of disciples, who met in the hotel of the Duc de Bellegarde, and death, so the story goes, struck him while he was engaged in rounding a period. Though he had a considerable fortune, he incessantly bewailed the rigours of his lot in his addresses to the court, and successfully importuned Louis XIII. for an addition to his income. He died at Paris, October 16, 1628. His poetry is of little merit, being cold, colourless, and insipid. He is best remembered by the truly touching stanzas which he addressed to his friend Du Perrier, and which contain the most famous line: 'Et, rose, elle a vécu ce qu'on vivent les roses.' He was exceedingly vainglorious, and asserted that what he had written would endure eternally. His interest lies in this—that by example and teaching he altered the complexion of French verse. He led his countrymen to look with disdain on the richly-coloured and full-sounding verses of Ronsard, and to adopt a style clear and finished, it is true, but cold and prosaic, and confined to the limits of a narrow vocabulary. He delighted to be termed the tyrant of words and syllables. He introduced, so to speak, the principle of caste into diction. Certain words were adapted for poetic purposes, while others were to be rigidly excluded from literature. The result was that when Malherbe's teachings were developed by Boileau, and enforced by his high authority, French verse was deprived of nearly all that marks off poetry from prose. The select literary words lost their original edge and colour, and became incapable of rendering other than conventional ideas. On the other hand, Malherbe did good service in inculcating the virtues of reticence, refinement, and correctness in style.

See *Sainte-Benve's Camerac de Louis*, vol. viii.; Flippé's *Écrivains Normands* (1858); and works by Gournay (1852), Laur (Heidelberg 1869), Johannesson (Halle, 1881), Basset (3d ed. 1890), Allais (1892), and the Duc de Broglie (1896).

Malibran, MARIA FELICITA, mezzo-soprano singer, born at Paris, March 24, 1808, was the daughter of Manuel Garcia, a Spanish singer and teacher of singing. She made her debut in London in 1825, and soon her reputation extended over Europe. Her father attempted to establish the Italian opera in New York, but without success; and she married M. Malibran, a French merchant there, who soon became bankrupt. Thereupon she returned to the stage, and was received with great enthusiasm in France, England, Germany, and Italy. Her first marriage having been dissolved, she married M. Beriot, a famous violinist, in 1836; but on 23d September of that year she died at Manchester. She was one of the greatest of operatic singers.

Malic Acid, $H_2C_2H_2O_3$ (from Lat. *malum*, 'an apple'), occurs abundantly in most acidulous fruits, particularly in unripe apples, gooseberries, and currants, in which it is found as an acid or acid salt of potash or lime, which gradually changes into a neutral salt as the fruit ripens. It crystallises in groups of radiating acicular prisms, but, as the crystals are very deliquescent, it is usually obtained as a syrupy, semi-transparent mass, with a very sour smell, and readily soluble in water and alcohol. The chemical changes which this acid undergoes under the influence of various reagents are very singular, and serve to illustrate many points in vegetable physiology in reference to the maturation of fruits. Thus, nitric acid converts it into oxalic acid; hydrated potash, into oxalic and

acetic acids; ferments, into succinic, butyric, acetic, and carbonic acids and water.

Malignant Pustule. See ANTHRAX.

Malignants, a term used by the parliament men to designate those whom they considered to be the evil advisers of Charles I. They are so called in the Grand Remonstrance, Laud and Strafford being singled out as the most prominent, and to their door are laid all the evils which afflicted the kingdom. Afterwards the name was extended to all who sided with the king against the parliament.

Malines, or MECHLIN (Flem. *Mechelen*), a city of Belgium, on the navigable Dyle, 14 miles SSE. of Antwerp. It has fine squares, noble buildings, and wide regular streets, but is devoid of all signs of life and industry, having lost its former greatness, and fallen far behind other Belgian cities in commercial enterprise and industrial activity. As the see of the primate of Belgium it still retains a certain degree of ecclesiastical importance, and possesses numerous churches, the most noteworthy of which is St Rombold's cathedral, a vast building, covering nearly two acres, its interior adorned with Van Dyck's 'Crucifixion' and many other fine pictures and carvings. It was mostly built in 1437-52, but its clock-tower, 324 feet high, remains unfinished. The churches of St John and of Our Lady contain works by Rubens; the town-hall dates from the 15th century; the Cloth Hall (1340) is now used as a guard-house; noteworthy also are the splendid modern archiepiscopal palace, the Beguinage, the Salm inn (1534), and the monument to Margaret of Austria (1849). The manufacture of pillow-lace, so famous in the 17th century (see LACE), has been largely transferred to Brussels and elsewhere; but linen and woollen fabrics, beer, needles, &c. are made here. Pop. (1875) 49,181; (1889) 49,721.

Malingering is a term used in the British army to express the crime of feigning disease in order to obtain discharge from the service, or to escape some special duty. As defined in the Army Act of 1881 it implies some overt act, such as the previous application of a ligature, or the taking of some drug, which produced the appearance of the disease said to exist. A worse form of the same crime, 'wilfully maiming'—as blowing off the trigger-finger—is erroneously called malingering.

Mallard. See DUCK.

Malleability is the property which certain metals possess of being reducible to thin leaves, either by hammering (hence the corresponding German word, *Hammerbarkeit*) or by lamination between rollers. The order in which the malleable metals exhibit this property is as follows: Gold, Silver, Copper, Platinum, Palladium, Iron, Aluminium, Tin, Zinc, Lead, Cadmium, Nickel, Cobalt. Gold far surpasses all the other metals in malleability, being capable of reduction into films not exceeding the 200,000th of an inch in thickness; and silver and copper may be reduced to leaves of great tenuity. Although gold and silver also present the property of Ductility (q.v.) in the highest degree, there is no constant relation between the two properties; for example, iron, although it may be reduced to extremely thin wire, is not nearly so malleable as gold, silver, or copper.

Mallee Scrub, a bushy Eucalyptus 8 or 10 feet high, which forms impenetrable thickets in Australia (q.v., Vol. I, p. 589). For the Mallee hen, see MOU AND BIRDS.

Mallet, or MALLEY, CLAUDE FRANCOIS DE, a conspirator against Napoleon I., was born 28th June 1751, at Dôle in Franche-Comté, and became an eager supporter of the Revolution.

Entering the army, he had risen to the rank of a brigadier-general by 1799. But in 1801 he was detected in a conspiracy against Napoleon, and again in 1808; he was arrested and kept in confinement until 1812. During Napoleon's campaign in Russia Mallet made his escape from prison on the night of October 22-23, and by circulating the false news of Napoleon's death and by dexterous use of a forged decree of the senate won over some of the national guards. Whilst the latter occupied the principal public offices in his name, Mallet himself proceeded to liberate his fellow-conspirators, Generals Guidal and Lahorie, from prison. But at the house of Hulin, commandant of the troops in Paris, Mallet was himself taken prisoner by Hulin's adjutant, Laborde. He was shot, along with his fellow-conspirators, 29th October 1812. See histories of the conspiracy, by Lafon (1814), Saulnier (1834), and Douville (1840).

Mallet, or MALLOCH, DAVID, the wielder of a venal pen under the second and third Georges, was born about 1705, at Crieff, where his father was a Roman Catholic small farmer. Janitor for six months at the High School, Edinburgh (1717-18), he then studied for one session at the university, and in 1720 became tutor in the family of Mr Home of Dregghorn, in 1723 in that of the Duke of Montrose. Here he remained several years, and made the tour of Europe with his pupils. In 1723 the adaptation of two old ballads into a new one, 'William and Margaret,' gained him a reputation as a poet, which he enhanced by a poem, *The Excursion* (1728). After this, having 'by degrees cleared his tongue from his native pronunciation, so as to be no longer distinguished as a Scot, . . . he took upon him to change his name from Scotch Malloch to English Mallet'—an instance of his insufferable vanity. Strange to say, Pope, the poet, was his friend, and to please him Mallet reviled Bentley in a work in verse, *Verbal Criticism* (1733). About this time he was appointed under-secretary to Frederick, Prince of Wales, then holding a separate court from his father's. In 1740 Mallet published a mediocere life of Bacon, and in 1742 another fairly creditable poem, *The Hermit, or Amyntor and Theodora*. After this he appears in the most despicable character: to gratify Bolingbroke he heaped abuse upon his dear friend Pope in a preface to Bolingbroke's *Patriot King*; at the bidding of the ministry he directed the popular rage for the loss of Minorena upon Admiral Byng, and his reward for this 'price of blood was,' says Dr Johnson, 'a pension which Mallet retained till his death;' and he received a legacy of £1000, besides other sums, to write a life of the great Duke of Marlborough, but never penned a single line—'he groped for materials and thought of it till he had exhausted his mind.' He also tried his hand at play-writing, but with no very great success: *Mustapha* pleased for a while in 1739, because it was thought to contain some political allusions; *Eurydice* (1731) and *Elvira* (1763), tragedies, were failures. *Alfred, a Masque* (1740) was written in conjunction with Thomson, and one of its songs, 'Rule Britannia,' has been claimed for both of them. Besides, Mallet published two volumes of miscellaneous verse. He died on 21st April 1765.

Mallow, a market-town and watering-place of Ireland, is beautifully situated on the left bank of the Blackwater, 20 miles by rail N. by W. of Cork. On the opposite side of the river, which is here crossed by a bridge, is the suburb of Ballydaheen. The town is resorted to in summer on account of its tepid mineral waters, and contains a

neat spa-house. Close by is the ivy-covered ruin of the castle of the Desmonds, destroyed in 1611, and the later Mallow Castle, built by Sir Denham Norreys towards the end of the 18th century. Tanning and some small manufactures are carried on. Pop. (1851) 5436; (1881) 4439; (1891) 4366. Till 1885 Mallow returned one member to the House of Commons.

Mallow (*Malva*), a genus of plants of the natural order Malvaceæ, whose species are herbaceous plants, or more rarely shrubs. The Common Mallow (*M. sylvestris*) is plentiful over most of Europe, and in Britain on waysides and heaps of rubbish. It is a perennial, with rather large



Common Mallow (*Malva sylvestris*.)

bluish-red flowers on erect stalks. The Dwarf Mallow (*M. rotundifolia*), also a common native of Britain, has smaller whitish or reddish-white flowers. These two plants have a mucilaginous and somewhat bitter taste, and the leaves are used as an emollient and demulcent medicine, a decoction of them being employed in cases of irritation of the pulmonary and of the urinary organs; and poultices made of them are very frequently employed to allay external inflammation. Other species have similar properties. The Musk Mallow (*M. moschata*), not infrequent in England, but rare in Scotland, has a faint musk-like smell. The fibre of *M. crispa* is used in Syria for textile purposes, and the fibres of many species are probably fit for similar use, and for the manufacture of paper. The young leaves of some are boiled as vegetables. A Mallow (*Lucatera arborea*) grows on the Bass Rock and Haddingtonshire. The Marsh mallow (q.v.) belongs to another genus.

Malmaison, a château standing on the left bank of the Seine, 10 miles W. of Paris, was the favourite residence of Josephine, wife of Napoleon I., and here she died. The château belonged to Richelieu, and was restored by Napoleon III. in 1861. A sortie by Durot from Paris in 1870 was repulsed here by the Germans. See a work by Lesene (1867).

Malmedy, a Prussian town in a mountain valley, close to the Belgian frontier and 51 miles S. of Aix-la-Chapelle, with mineral springs. Pop. (1895) 4500, mostly Walloons, speaking French.

Malmesbury, an old-world market town of Wiltshire, on a bold eminence between two head-streams of the Avon, 26 miles by rail NNE. of Bath and 17 WNW. of Swindon. It owes its name to Maelduff, an Irish missionary. Abhelm (q.v.), his scholar, became about 673 first abbot of the famous abbey here, in which Athelstan was buried, and of which William of Malmesbury was librarian

and precentor in the first half of the 12th century. To his time belong the building of a short lived castle, and the rebuilding (also by Bishop Roger of Salisbury) of the abbey church, which, Transition Norman in style, and cruciform in plan, with a central spire, was 350 feet long. Little more than the nave—now the parish church—remains; but this is a most interesting fragment, its finest feature the south porch. At the Dissolution (1539) the mitred Benedictine abbey became a cloth factory. A beautiful market-cross (temp. Henry VII.) is noteworthy. Hobbes was a native. Malmesbury returned two members till 1832, and then one till 1885. Pop. of borough (incorporated 1886), 2964.

See works by Moffatt (1805), Sir T. Phillips (1831), J. E. Jackson (1863), W. de Gray Birch (1874), and the *Register of Malmesbury*, edited by Brewer and Martin (2 vols. 1879-81).

Malmesbury, JAMES HARRIS, first EARL OF, diplomatist, was born at Salisbury, 21st April 1746, the only son of James 'Hermes' Harris (q.v.). Educated at Winchester, at Merton College, Oxford, and at Leyden, in 1768 he became secretary of legation at Madrid, and in 1772 minister at Berlin, in 1777 at St Petersburg, in 1784 at The Hague. In 1779 he received the Order of the Bath, and in 1788 was created Baron, in 1800 Earl of, Malmesbury. Meanwhile, in 1793, with other Whigs he had succeeded from Fox to Pitt, and in 1795 had married by proxy and conducted to England the Princess Caroline. 'I'm not well, Harris; get me a glass of brandy, Harris'—one remembers the Prince's reception of his bride. Very deaf during the last twenty years of his life, Lord Malmesbury died in London, 20th November 1820. See his *Diaries and Correspondence* (1844), and *Lord Malmesbury and his Friends* (1870), both edited by his grandson.

That grandson, JAMES HOWARD HARRIS, third EARL OF MALMESBURY, was born in London, 25th March 1807, and from Eton proceeded to Oriel College, Oxford. He took his B.A. in 1827, and then made a continental tour (1828-29), during which at Rome he formed a close friendship with Louis Napoleon. In 1837 he stood as a Tory for Portsmouth, and in 1841 had just been returned for Wilton, when his father's death called him to the House of Lords. In 1852 he was Foreign Secretary under Lord Derby, as again in 1858-59, when his policy prior to the outbreak of the Franco-Austrian war was directed wisely if unsuccessfully to the preservation of the peace of Europe. In 1866-68, and again in 1874-76, he was Lord Privy Seal; in 1884 appeared his valuable and entertaining *Memoirs of an Ex-Minister*. He died 17th May 1889.

Malmesbury, WILLIAM OF, an early English historian, was born near the close of the 11th century, and was educated in the monastery at Malmesbury, where he became a monk, and in due time librarian, and afterwards precentor. In 1140 he declined the office of abbot, took part in the council at Winchester against Stephen in 1141, and died most probably soon after 1142, when his latest work, the *Historia Novella*, comes abruptly to an end. His two principal works are *Gesta Regum Anglorum* and *Gesta Pontificum Anglorum*. The former gives the history of the kings of England from the Saxon invasion to the twenty-eighth year of Henry I., or the year 1128. The *Historia Novella* brings down the narrative to the year 1142, but is really a separate work. Sir T. D. Hardy edited both together for the English Historical Society in 1810. Sharpe's translation (1815) was included in Bolin's 'Antiquarian Library' in 1847. The two form admittedly one of the most valuable authorities for the Anglo-Norman period of our

history, the work of a man of great learning, industry, intelligence, and impartiality—no mere compilation, and written moreover with unusual clearness and force. The *Gesta Pontificum* gives an account of the bi-shops and principal monasteries of England from the conversion of Ethelbert of Kent by St Augustine to 1123. It was edited in the Rolls series in 1870 by Mr N. E. S. A. Hamilton. Other works of William's are an account of the church at Glastonbury, printed in Gale's *Scriptores* XVI., and a life of St Dunstan, printed in Wharton's *Anglia Sacra*.

Malmö, the third largest town of Sweden, on the Sound, nearly opposite Copenhagen, 17 miles distant. Besides being a busy seaport, it has manufactures of cigars, sugar, beer, and woollens, and some shipbuilding. The exports (chiefly grain, flour, butter, eggs, cement, chalk, matches, live-stock, and timber) are carried away every year in about 3500 vessels of 750,000 tons burden, and the imports (coal, machinery, cotton, grain, textiles, coffee, &c.) brought by 3600 vessels of 720,000 tons. The only remaining part of the old fortifications is the castle in which the Earl of Bothwell (q.v.) was confined: it is now used as a prison. The town-house is a fine Renaissance building of 1546. Pop. (1874) 30,676; (1888) 46,283. Down to the 16th century Malmö was one of the busiest commercial towns in that part of the Baltic. In 1523 a treaty of peace between the Danes and Gustavus Vasa was signed here.

Malmsey (Fr. *vin de Malvoisie*), a name bestowed originally on the red and white wines of Napoli di Malvasia or Monemvasia, in the Morea, not because it produced them, but because it exported them: they were grown in the islands of the Egean and the Levant. The Malmsey wines of modern commerce are mostly the produce of Teneriffe, Madeira, the Azores, Sardinia, Sicily, and one or two other places.

Malone, EDMUND, editor of Shakespeare, was born in Dublin, 4th October 1741, graduated with credit at the university there, and was called to the Irish bar in 1767. Falling soon after into a fortune, he went to London to devote himself to literary pursuits, his first work being a 'supplement' to Steevens's edition of Shakespeare (1778). His contributions to Steevens's third edition of Shakespeare (1785) led to a serious quarrel between the two, in which Steevens was wholly to blame. Malone's own edition of the great dramatist (1790) was warmly received, especially the essays on the 'History of the Stage' and the 'Genuineness of the Three Plays of Henry VI.' As an editor Malone displays great good sense, conscientiousness, much acuteness, extensive research, and a becoming respect for the text of the earlier editions. He had been one of the first to express his unbelief in the antiquity of Chatterton's Rowley poems, and in 1796 he denounced the impudent forgeries of the wretched Ireland. Next year he published a posthumous edition of the works of his friend Sir Joshua Reynolds. His own death occurred 25th May 1812. He left behind a large mass of materials for another edition of Shakespeare, which at length appeared in 1821, in 21 vols., under the editorship of James Boswell the younger, and as the 'Variorum Shakespeare' is known and valued by all scholars. See Life by Sir James Prior (1860).

Malory, SIR THOMAS, is immortal in his work, the *Morte Darthur*, while of himself but little is known. We learn from Caxton's preface that Malory was a knight, that he finished his work in the ninth year of the reign of Edward IV. (1470), that he 'reduced' it from some French book, and that he was a servant of Jesus both day and night—a statement which has needlessly led to the

inference that he was a priest. In Leland's *Itinerary* the name occurs in Yorkshire, and the century after in Burton's *Description of Leicestershire*, but there is no evidence to connect the writer with either county. Caxton's impression was finished in 1485, and is a black-letter folio, of which but two copies now exist. An accurate and altogether admirable edition of it was reprinted in 1889 by the care of Dr H. Oskar Sommer. The editor's Introduction followed in 1890; his Treatise on the Sources and Andrew Lang's Essay on Malory's Prose Style in 1891. There were twelve preceding editions, including those of Wynkyn de Worde, W. Copland, Hazlewood (1816), Southey (1817), Thomas Wright (1856), and Sir E. Strachey (the Globe edition, 1868). The last three have admirable introductions.

Sir Thomas Malory's work 'is indisputably,' says Scott, 'the best prose romance the English language can boast of.' It was due to an attempt to work up and give an epic unity and harmony to the whole mass of French romance, and the result shows that its author was no slavish copyist or compiler merely, but that he turned much that was dross into pure gold, and stamped upon the whole the impress of his own individuality as Shakespeare did with his Holinshed and Plutarch. And this no less in the events than the characters of the story as the modern reader realises them glorified through the medium of Tennyson's stately verse. The story moves forward with dignity to its tragic close, the inevitable issue of the guilty loves of Lancelot and Queen Guinevere.

Malpighi, MARCELLO, an Italian anatomist, was born at Crevalore, near Bologna, on 10th March 1628, and died at Rome on 29th November 1694. He held, at different periods of his life, the professorship of Medicine in Pisa (1656-60), Messina (1662-66), and Bologna (1666-91). In 1691 he was appointed chief physician to Pope Innocent XII. Like his contemporary Leeuwenhoek, he was a pioneer in the study of minute anatomy with the microscope, and is chiefly known for his discoveries in connection with capillary circulation and in the anatomy of the skin, the kidney, and the spleen (see KIDNEYS). Amongst his works may be mentioned *Epistola Anatomica* (1662), *De Structura Viscerum* (1669), *De Pulmouibus* (1661), *De Structura Glandularum Conglobatarum* (1689), and *Anatomia Plantarum* (1675-79). See the bicentenary monograph by Atti, Virchow, Haeckel, Todaro, Michellis, and others (Milan, 1898).

Malpighiaceae, a natural order of exogenous plants, trees or shrubs, many of them climbing shrubs or lianas.

Malplaquet, a village in the French department of Nord, 10 miles S. of Mons in Belgium. Here, on 11th September 1709, over 90,000 British and Dutch, under Marlborough and Prince Eugene, defeated about the same number of French under Marshal Villars. In this 'very murderous battle,' as Marlborough called it, the loss of the allies was from twenty to thirty thousand, of the French from six to sixteen thousand. Its result was the capture of Mons.

Malström. See MAELSTROM.

Malt and Malting. See BEER.

Malta, an island and British possession in the Mediterranean, 17½ miles long by 8½ broad, with an area of 95 sq. m. It stands on the submarine plateau which, stretching across from Sicily to Africa, divides the Mediterranean into two basins, and is of late Eocene or perhaps Miocene formation, the prevailing rocks being limestones. From its central position in the Mediterranean Sea, 58 miles S. of the Sicilian coast and about 180 SE. by

E. of Cape Bon in Algeria, and from the enormous strength of its fortifications. Disraeli called it 'the little military hothouse'—Malta is one of the most important of the British dependencies. It is the headquarters of the British Mediterranean fleet, the principal coaling station for merchant-vessels as well as the navy in the Mediterranean—between 500,000 and 600,000 tons of coal are imported for use and re-exportation annually—a powerful stronghold (Valletta), a valuable sanatorium for troops employed in the Orient, and an interesting island historically, architecturally, and from the antiquarian standpoint. The dependencies include the island of Gozo (20 sq. m.), lying NW. of Malta, and separated from it by a channel 3 miles wide, in which are the little islands of



Comino and Cominotto, and several islets round the coasts of the larger islands. On one of these islets, General's Rock, near the west side of Gozo, the famous Maltese fungus *Cynomorium* (q.v.) grows. The area of the entire governorship of Malta extends to 117 sq. m. The island of Malta is oval in shape, the north-eastern and eastern shores being broken into several good harbours (Valletta, Marsa Scirocco, St Paul's Bay, Mellieha Bay, &c.); the southern coast rises in picturesque cliffs 400 feet high. The culminating point of the island is 758 feet. The sea has hollowed out among its cliffs grottoes and caverns in almost every direction, some of considerable extent, especially one in Comino. Malta has a bare, stony appearance, owing to the absence of trees and the fact that the fields and gardens are enclosed in high walls, to shelter the crops against the violent winds. There are no rivers or lakes; but water is easily obtained from springs. The soil is thin, but remarkably fertile; and its fertility is increased by the skilful cultivation and the diligent toil of the inhabitants. Large crops of wheat and potatoes are raised, early varieties of the latter being largely exported to England; maize, barley, cotton, clover, oranges, figs, grapes, earob beans, and peaches and other fruits are also grown. Fine honey is produced; in spring the island is gay with flowers. Those of the Maltese who do not cultivate the soil are chiefly engaged in the docks and harbours. Filigree ornaments and a little cotton are manufactured. Sheep and goats are kept, with smaller numbers of cattle, mules, asses, and horses. The Maltese Dog (q.v.) is virtually extinct. During the summer months the thermometer ranges from 75 to 90° F., during the coldest from 59 to 71.

The annual mean is 67.3 F., and the annual rainfall 24.23 inches. But when the hot sirocco wind blows—not dry as in Africa, but laden with moisture—the climate is enervating. Otherwise Malta is fairly healthy, though cholera pays occasional visits, as in 1853 and 1887; since about 1880 the government have been providing the island with a comprehensive system of water-works, which has greatly contributed to its healthfulness. Earthquakes are relatively frequent.

In 1881 Malta (132,129) and Gozo (17,653) contained 149,782 inhabitants; in 1891, 177,225 (including 2300 British residents and 1200 foreigners, but excluding the 6000 to 7000 imperial troops). The local militia, including the Royal Malta Fencible Artillery, number about 1200. The language of the people is a corrupt dialect of Arabic, with a strong admixture of Italian and other words; some authorities, however, connect it with the ancient Phœnician. The native population believe themselves to be of Phœnician descent. From the time of the settlement of the Knights of St John down to quite recently Italian was the official language; but it has been superseded by English. Most of the educated Maltese speak Italian, and some speak English; the peasantry as a rule know neither the one nor the other. The Maltese are a sober, industrious race of people, though often quick-tempered and ignorant. Their thrifty habits are proved by the fact that 5197 depositors had £402,969 standing to their credit in the savings-bank in 1888. They are fond and proud of their island home—they love to call it 'the flower of the world'—and are devout Roman Catholics, the power of the Church being very great over the people. There are two bishops (Malta, Gozo) and 1200 clergy. Canon law is recognised as the civil law of Malta. Owing to the rapid growth of the population and their density to the sq. m. (1471 in Malta and 931 in Gozo; Belgium has 514 to the sq. m.), large numbers are compelled to emigrate; they are found to the number of 50,000 in all parts of North Africa and the Levant. Education is provided for in a university, a lyceum (400 pupils), and nearly fifty government schools, attended by 10,000 pupils. The university, founded in 1769, has four faculties and (1888) 105 students. The educational condition of the island had long been a subject of discontent; but reforms were introduced in the end of 1887, after which the number of students at the university more than doubled, and a thousand more pupils attended the primary schools. Yet other causes of discontent existed in the ecclesiastical jealousy of the predominant church, and social jealousy between the impoverished native nobility (for the most part counts and marquises created by the Knights of St John, and fully recognised since 1878) and the upper classes of the British. Within the last few years the sovereign power has shown more consideration for the political susceptibilities, and also for the social welfare, of the people. The fortified towns that constitute Valletta have been drained, water has been carried throughout Malta, and in 1890 was to be carried over Gozo likewise, and the old Maltese coinage of the knights was superseded (1887) by the British currency (silver being legal tender up to £5). Moreover, a constitution based on popular representation was conferred in 1887. Legislation is carried on by six official and fourteen elected members, the governor, with the power of veto, being president. There is also an executive council, consisting of the governor as president, seven official members, and three nominated by the governor from among the elected members of the legislative chamber; the crown retains the right to legislate also through orders in council. There is no direct taxation in Malta.

The government own two-sevenths of the land (the rest is divided about equally between the ecclesiastical establishments and private owners); from the rents of this and other crown property, and from customs, licenses, &c., the annual revenue of £260,000 to £300,000 is derived. The public debt is £80,000 (1895). There is a railway, 8½ miles long, connecting Valetta (q.v.), the present capital, with the old capital Citta Vecchia, known to Cicero as Melita, to the Saracens as Medina, and to the modern Maltese as Notabile, a place founded so long ago as 700 B.C. Here is the cathedral of St Paul (1697), traditionally occupying the site of a palace of Publius, who erected there a church, and of a former cathedral built by the Normans in the 12th century and destroyed by earthquake in 1693. The cathedral is adorned with mosaics, pictures, statues, and other works of art. Near by are the extensive catacombs and the Grotto of St Paul, where he is popularly believed to have lived during his three months' stay on the island. Two miles distant is the Verdala Palace, built by the grand-master Verdala in 1586, and now a summer residence of the governor of the island. At Mnaidra and Hagiar Kim, in the south of the island, there are megalithic Phœnician temples, the ground-plans, not only of the general structures, but also of the detailed compartments, being all elliptical in shape. The traditional scene of St Paul's shipwreck is on the north side of the Bay of St Paul. The church of Musta (1833-64) is designed on the model of the Pantheon at Rome, and has the largest dome in Europe next after those of St Peter's and the Pantheon. Some 8000 vessels of 6,000,000 tons enter and clear the island ports every year, with cargoes varying in value from £25,000,000 to £70,000,000. But of the total imports (worth nearly £36,000,000 in 1891, in 1894 hardly £14,000,000) only a fraction—say £800,000—is actually retained in the island; the rest is re-exported.

The *Hyperion* or *Ogygia* of Homer is sometimes identified with Malta. The Phœnicians colonised the island at a very early date, more than 1000 years before the birth of Christ. Before they were disturbed in their possession by the Greeks, about 700 B.C., they had developed considerable commerce. The Greeks, who called the island *Melita*, were driven out by the Carthaginians about 480 B.C. As early as the first Punic war Malta was plundered by the Romans, but did not come definitively into their hands until 216 B.C. In those early times Malta was renowned for its manufactured cotton, its roses, and its honey; and its Roman temples and villas boasted excellent works

of art and other indications of great luxury. On the division of the Roman world (395) Malta followed the fortunes of the eastern empire. During the 5th century it fell successively under the Vandals and the Goths; and though in 533 Belisarius recovered it for the Byzantine empire, its prosperity departed, and its civilisation almost vanished amid constant local feuds. In 870 the Arabs destroyed the Greek power in Malta, and fortified the harbour. Count Roger of Sicily drove out the Arabs in 1090. As a tief of Sicily, Malta passed, under a marriage-contract, to the Emperor Henry VI. (1194). In 1282 the island was conquered by Pedro of Aragon, and, so coming eventually into the hands of Charles V., was given by him, along with Gozo and Tripoli, in perpetual sovereignty to the Knights of the Order of St John of Jerusalem (1530). The Knights raised the stupendous fortifications which rendered Malta so powerful, and spent much wealth in beautifying the island. To revenge their attacks on the Barbary pirates, Sultan Solyman sent in 1565 a very powerful fleet, strengthened by the galleys of Dragut of Tripoli, against the forts. Valetta was founded in the following year, after the Turkish attack, which lasted three months, had been beaten off (see VALETTA). In 1571 the Maltese followers of the Knights of St John behaved courageously at the battle of Lepanto. The Hospitallers continued in possession of Malta until 1798, when they surrendered their fortresses to the French. The Maltese, however, rose in a few months against their new masters, who treated them ill, and after a siege of two years, during which they were assisted by Neapolitan and British forces, they forced the French to capitulate to the English general Pigot. The treaty of Amiens stipulated that Malta should be restored to the Knights of St John; but the Maltese protested against such an arrangement, and preferred the government of Great Britain. The British government consequently refused to give up the island, and Napoleon made the refusal one of his grounds for the resumption of hostilities. The Congress of Vienna (1814) finally recognised Malta as a British dependency.

See historical works on Malta by Miège (1840), Eton (1802), Ayles (1830), Tullack (1861), Winterberg (1879); Caruana's *Reports on Phœnician and Roman Antiquities in Malta* (1881-82); James Smith, *Voyage and Shipwreck of St Paul* (1866); Sir R. L. Playfair, *Mediterranean* (1890), in Murray's Guidebook series; and John Murray's valuable paper in *Scot. Geog. Mag.* (1890).

Malta, KNIGHTS OF. See HOSPITALLERS.

END OF VOL. VI.

